

Table 4-2 LED Charging Status Indicators

LED	Indication
Mobile Computer Charging (LED on mobile computer)	
Off	Mobile computer not placed correctly in the cradle; cable not connected correctly; charger is not powered.
Fast Blinking Amber	Error in charging; check placement of mobile computer.
Slow Blinking Amber	Mobile computer is charging.
Solid Amber	Charging complete. Note: When the battery is initially inserted in the mobile computer, the amber LED flashes once if the battery power is low or the battery is not fully inserted.
Spare Battery Charging (LED on cradle)	
Off	No spare battery in slot; spare battery not placed correctly; cradle is not powered.
Fast Blinking Amber	Error in charging; check placement of spare battery.
Slow Blinking Amber	Spare battery is charging.
Solid Amber	Charging complete.

Four Slot Cradles



CAUTION Ensure that you follow the guidelines for battery safety described in *Battery Safety Guidelines* on page 5-2.

There are two four slot cradles, *Four Slot Charge Only* cradle and *Four Slot Ethernet* cradle. The Four Slot Ethernet cradle provides Ethernet communications. Both four slot cradles:

- Provide 5.4 VDC power for operating the mobile computer and charging the battery.
- Simultaneously charges up to four mobile computers.

Battery Charging

The four slot cradle can charge up to four mobile computers simultaneously. To charge the mobile computer:

1. Slide the mobile computer into the mobile computer slot.

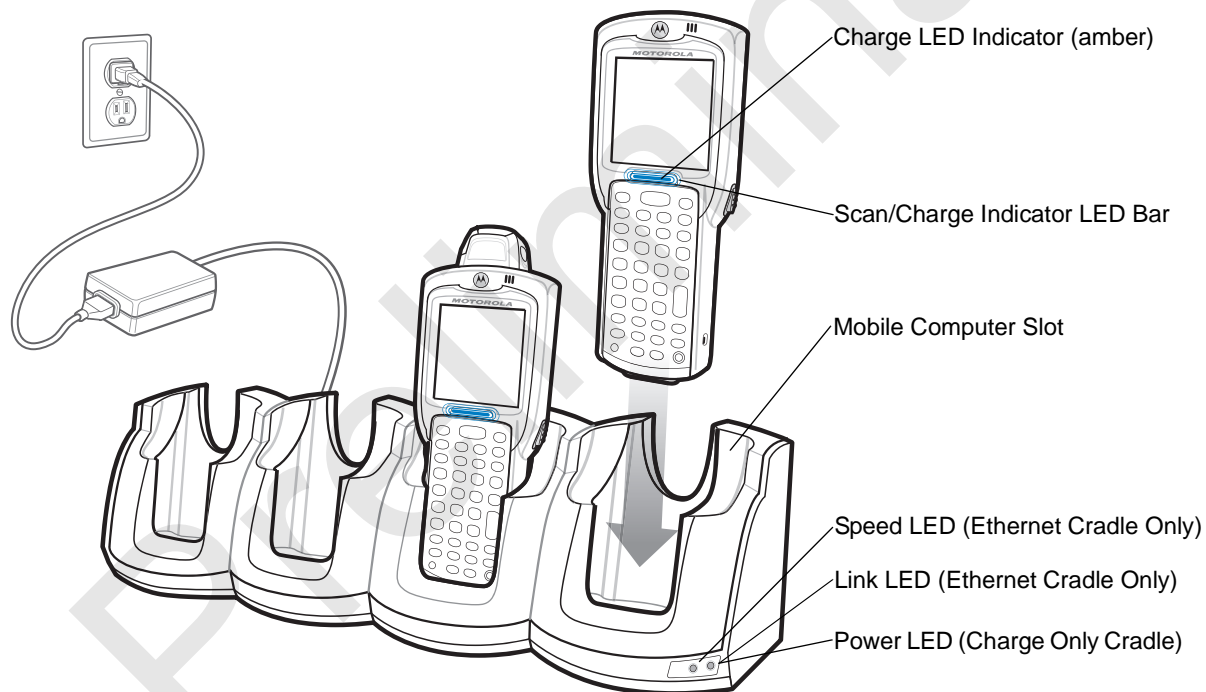

Figure 4-2 *Four Slot Cradles*

2. The mobile computer amber Charge LED Indicator, indicates the mobile computer battery charging status. The Standard Battery usually charges in less than four hours and the Extended Life Battery usually charges in less than six hours. See [Table 4-2](#) for charging status indications.
3. When charging is complete, remove the mobile computer from the cradle.

LED Charge Indications

The Four Slot cradles use the mobile computer amber Charge LED Indicator to indicate the battery charging status. See [Table 4-2 on page 4-5](#) for charging status indications.

Power LED

The green Power LED (only on the Four Slot Charge Only cradle) lights to indicate that the Four Slot Charge Only cradle is connected to a power source.

Speed LED

The green Speed LED (only on the Four Slot Ethernet cradle) lights to indicate that the transfer rate is 100 Mbps. When it is not lit it indicates that the transfer rate is 10 Mbps.

Link LED

The yellow Link LED (only on the Four Slot Ethernet cradle) blinks to indicate activity, or stays lit to indicate that a link is established. When it is not lit, it indicates that there is no link.

Four Slot Spare Battery Charger



CAUTION Ensure that you follow the guidelines for battery safety described in *Battery Safety Guidelines* on page 5-2.

The Four Slot Spare Battery Charger simultaneously charges up to four spare batteries.

Spare Battery Charging

To charge up to four MC31XX spare batteries:

1. Insert the spare battery into the spare battery charging slot, bottom first.
2. Pivot the top of the battery down onto the contact pins.

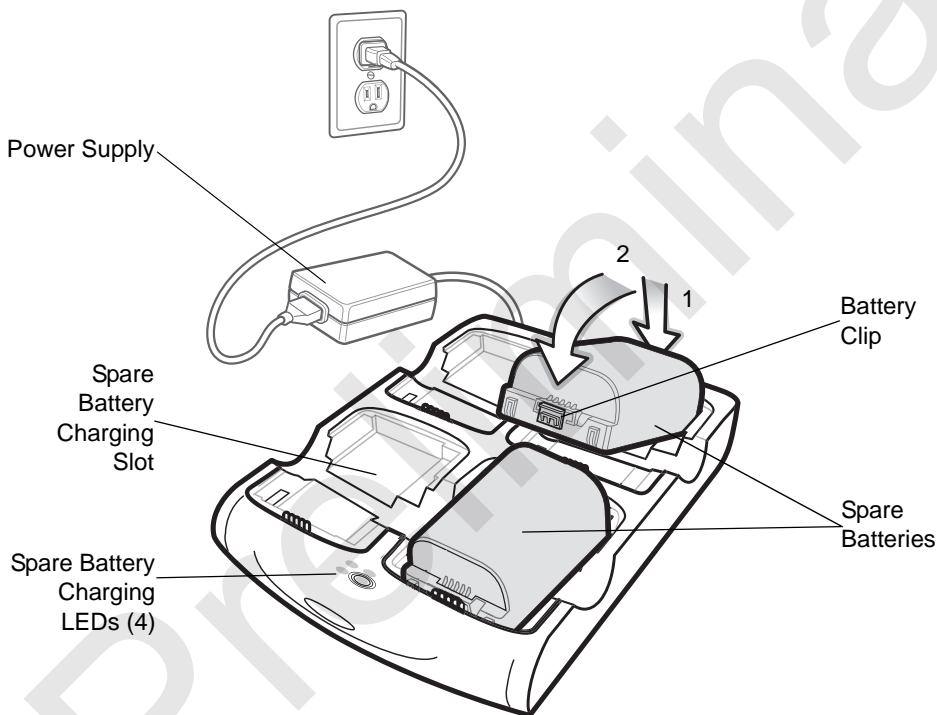

Figure 4-3 Four Slot Spare Battery Charger

3. Gently press down on the battery to ensure proper contact. The Standard Battery usually charges in less than four hours and the Extended Life Battery usually charges in less than six hours. See [Table 4-2 on page 4-5](#) for charging status indications.
4. When charging is complete, press the battery clip and lift battery out of the slot.

LED Charge Indications

The Spare Battery Charging LEDs indicate the spare battery charging status. The Spare Battery Charging LEDs are arranged in the same pattern as the spare battery charging slots so that the charging status of each battery can be identified. See [Table 4-2 on page 4-5](#) for charging status indications.

Cables

The cables are available with a variety of connection capabilities.

MC31XX Communication/Charge cables:

- Provide the mobile computer with operating and charging power when used with the Symbol approved power supply.
- Synchronize information between the mobile computer and a host computer. With customized or third party software, it can also synchronize the mobile computer with corporate databases.
- Provide serial connection through the serial pass-through port for communication with a serial device, such as a host computer. For communication setup procedures, refer to the *MC31XX Integrator Guide*.
- Provide USB connection through the USB pass-through port for communication with a USB device, such as a host computer. For communication setup procedures, refer to the *MC31XX Integrator Guide*.

The following MC31XX Communication/Charge cables are available:

- Serial (RS232) Charge cable (9-pin D female with power input receptacle)
- USB Client Charge cable (standard-A connector and a barrel receptacle for power).

Dedicated Printer cables, provide communication with a dedicated printer.

The following printer cables are available directly from the printer manufacturer:

- O'Neil printer cable
- Zebra printer cable
- Monarch printer cable.

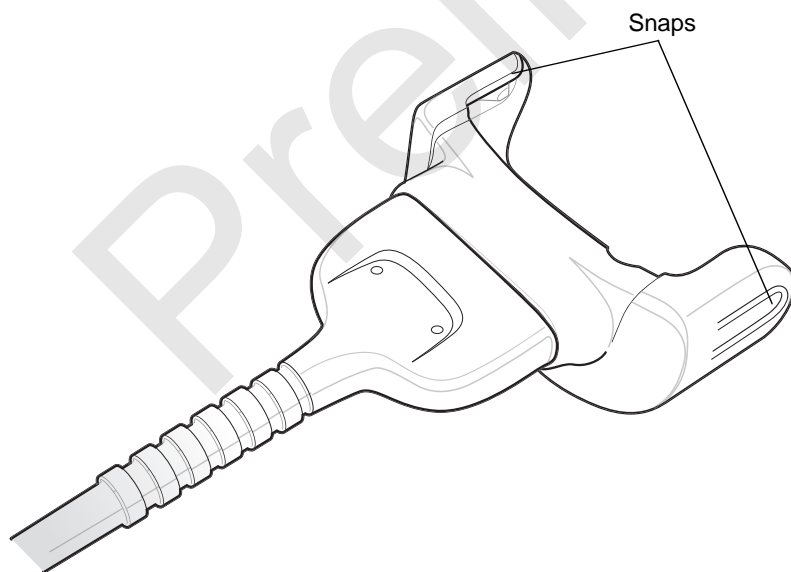

Figure 4-4 Cables

Battery Charging and Operating Power



CAUTION Ensure that you follow the guidelines for battery safety described in *Battery Safety Guidelines on page 5-2*.

The MC31XX Communication/Charge cables can charge the mobile computer battery and supply operating power.

To charge the mobile computer battery:

1. Connect the MC31XX Communication/Charge cable power input connector to the Symbol approved power source.
2. Slide the bottom of the mobile computer into the MC31XX connector end of the MC31XX Communication/Charge cable and gently press in until the snaps latch into the mobile computer.
3. The mobile computer amber Charge LED Indicator indicates the mobile computer battery charging status. The Standard Battery usually charges in less than four hours and the Extended Life Battery usually charges in less than six hours. See, [Table 4-2 on page 4-5](#) for charging status indications.
4. When charging is complete, remove the cable by gently pulling the mobile computer and the cable apart until the snaps release the mobile computer.

LED Charge Indications

The MC31XX Communication/Charge cables use the amber Charge LED Indicator to indicate the MC31XX battery charging status. See, [Table 4-2 on page 4-5](#) for charging status indications.

Universal Battery Charger (UBC) Adapter



CAUTION Ensure that you follow the guidelines for battery safety described in *Battery Safety Guidelines* on page 5-2.

The UBC Adapter can be used with a power supply as a standalone spare battery charger or it can be used with the four station UBC2000 to simultaneously charge up to four spare batteries. For additional information on the UBC 2000, refer to the *UBC 2000 Quick Reference Guide* p/n 70-33188-xx.

Spare Battery Charging

To charge spare batteries:

1. Insert the spare battery into the spare battery charging slot, bottom first.
2. Pivot the top of the battery down onto the contact pins.

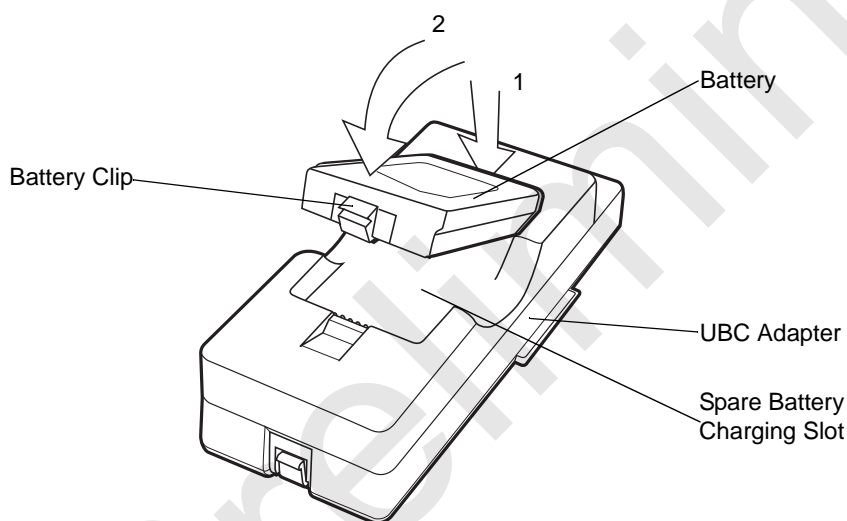

Figure 4-5 UBC Adapter Battery Insertion

3. Gently press down on the battery to ensure proper contact. The Standard Battery usually charges in less than four hours and the Extended Life Battery usually charges in less than six hours. See, [Table 4-3 on page 4-12](#) for charging status indications.
4. When charging is complete, press the battery clip and lift the battery out of the slot.

UBC Adapter LED Charge Indications

The UBC Adapter charging LEDs indicate the battery charging status. The Standard Battery usually charges in less than four hours and the Extended Life Battery usually charges in less than six hours.

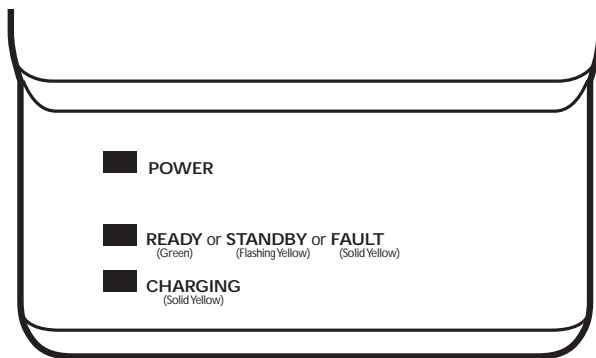

Figure 4-6 UBC Adapter LEDs

Table 4-3 UBC Adapter Charge LED Status Indications

LED	Indication	Description
POWER	Green	Power is connected to the UBC Adapter.
READY or	Green	Charging complete.
STANDBY or	Flashing-Yellow	The battery was deeply discharged and is being trickle charged to bring the voltage up to the operating level. After operating level voltage is achieved, the battery charges normally.
FAULT	Yellow	Charging error, check placement of mobile computer/spare battery.
CHARGING	Yellow	Normal charge.

Fabric Holster

The Fabric Holster provides a soft holder for the mobile computer. It consists of a fabric mobile computer holder, a detachable shoulder strap and a detachable belt clip. Press the release button to remove the detachable belt clip. See [Figure 4-10](#) to remove the detachable clip see [Figure 4-11 on page 4-15](#) to attach the Fabric Holster to a belt and see [Figure 4-12 on page 4-16](#) to attach the Fabric Holster to a shoulder strap.

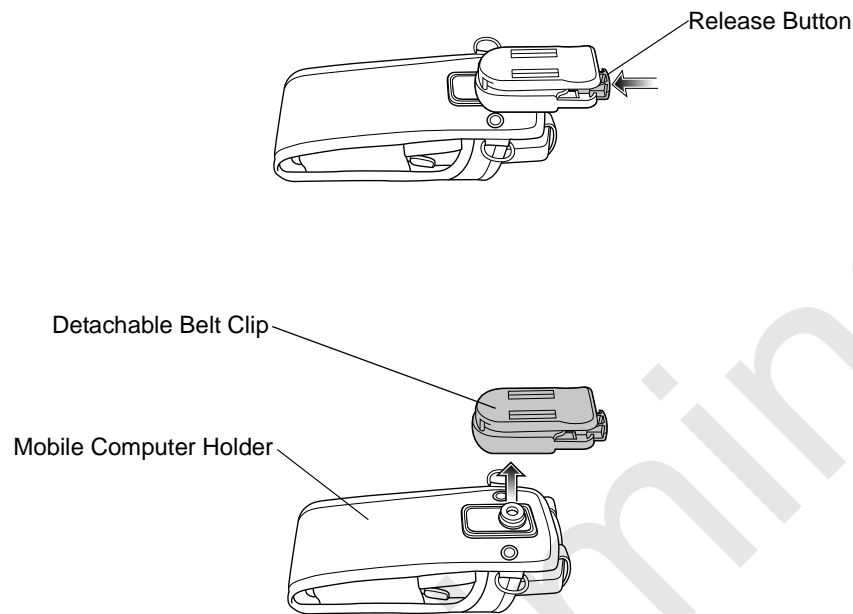

Figure 4-10 *Fabric Holster Detachable Belt Clip*

Belt Clip

Pinch the clip release and attach the Fabric Holster to a belt or waist band.

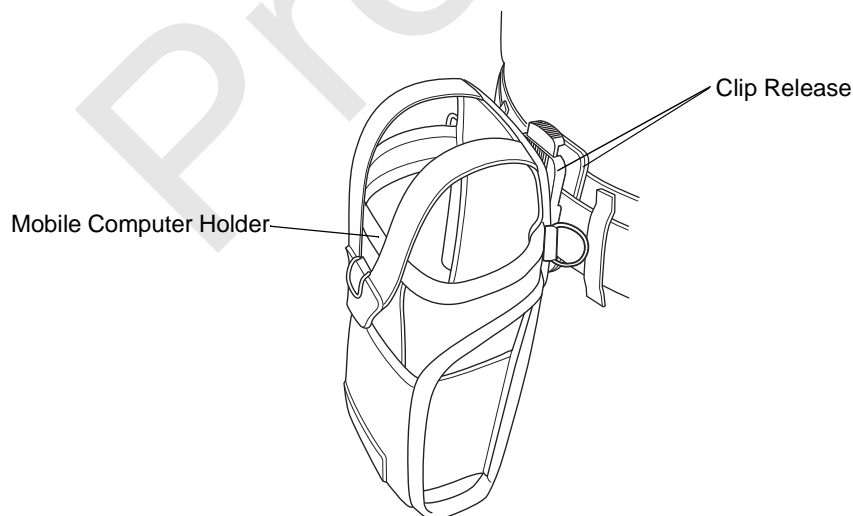

Figure 4-11 *Attaching the Fabric Holster To a Belt*

Shoulder Strap

Remove the detachable belt clip (see [Figure 4-10 on page 4-15](#)) and attach the shoulder strap.

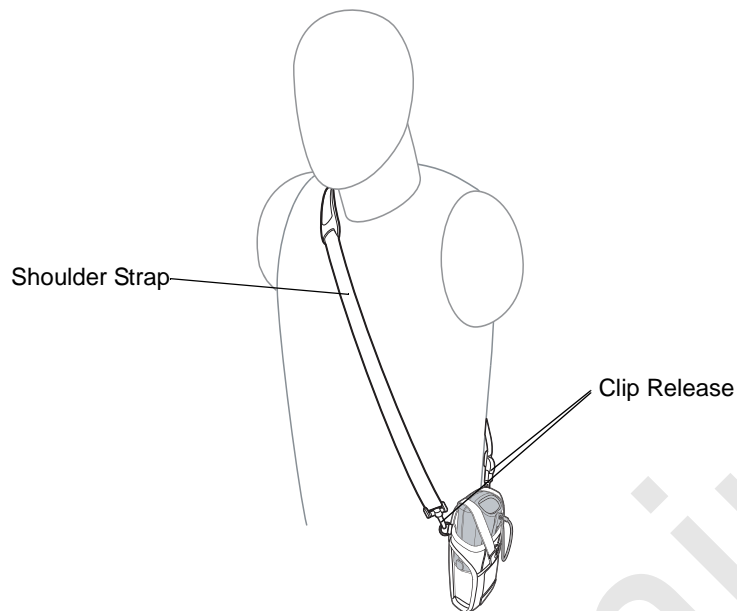

Figure 4-12 *Attach the Fabric Holster To the Shoulder Strap*

The Fabric Holster holds the mobile computer on a belt or waist band.

1. To insert the mobile computer, slide the mobile computer into the Fabric Holster with the screen facing the user.
2. Pull restraining strap over mobile computer and secure in the clip.
3. To remove the mobile computer, pull down on restraining strap to release from clip and lift retaining strap clear.
4. Lift mobile computer out of Fabric Holster.

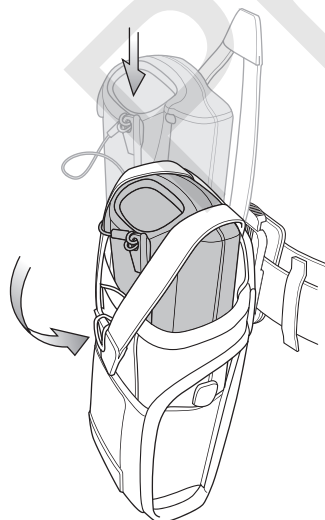

Figure 4-13 *Insert and Remove the Mobile Computer*

Chapter 5 Maintenance and Troubleshooting

Introduction

This chapter includes instructions on cleaning and storing the mobile computer, and provides troubleshooting solutions for potential problems during mobile computer operation.

Maintaining the Mobile Computer

For trouble-free service, observe the following tips when using the mobile computer:

For trouble-free service, observe the following tips when using the MC31XX:

- Do not scratch the screen of the MC31XX. When working with the MC31XX, use the supplied stylus or plastic-tipped pens intended for use with a touch-sensitive screen. Never use an actual pen or pencil or other sharp object on the surface of the MC31XX screen.

Motorola recommends using a screen protector, p/n KT-122010-01R.

- The touch-sensitive screen of the MC31XX is glass. Do not drop the MC31XX or subject it to strong impact.
- Protect the MC31XX from temperature extremes. Do not leave it on the dashboard of a car on a hot day, and keep it away from heat sources.
- Do not store or use the MC31XX in any location that is dusty, damp, or wet.
- Use a soft lens cloth to clean the MC31XX. If the surface of the MC31XX screen becomes soiled, clean it with a soft cloth moistened with a diluted window-cleaning solution.
- Periodically replace the rechargeable battery to ensure maximum battery life and product performance. Battery life depends on individual usage patterns.

- A screen protector is applied to the MC31XX. Motorola recommends using this to minimize wear and tear. Screen protectors enhance the usability and durability of touch screen displays. Benefits include:
 - Protection from scratches and gouges
 - Durable writing and touch surface with tactile feel
 - Abrasion and chemical resistance
 - Glare reduction
 - Keeping the device's screen looking new
 - Quick and easy installation.

Battery Safety Guidelines

- The area in which the units are charged should be clear of debris and combustible materials or chemicals. Particular care should be taken where the device is charged in a non commercial environment.
- Follow battery usage, storage, and charging guidelines found in the user's guide.
- Improper battery use may result in a fire, explosion, or other hazard.
- To charge the mobile device battery, the battery and charger temperatures must be between +32 °F and +104 °F (0 °C and +40 °C)
- Do not use incompatible batteries and chargers. Use of an incompatible battery or charger may present a risk of fire, explosion, leakage, or other hazard. If you have any questions about the compatibility of a battery or a charger, contact Motorola Enterprise Mobility support.
- For devices that utilize a USB port as a charging source, the device shall only be connected to products that bear the USB-IF logo or have completed the USB-IF compliance program.
- To enable authentication of an approved battery, as required by IEEE1725 clause 10.2.1, all batteries will carry a Motorola hologram. Do not fit any battery without checking it has the Motorola authentication hologram.
- Do not disassemble or open, crush, bend or deform, puncture, or shred.
- Severe impact from dropping any battery-operated device on a hard surface could cause the battery to overheat.
- Do not short circuit a battery or allow metallic or conductive objects to contact the battery terminals.
- Do not modify or remanufacture, attempt to insert foreign objects into the battery, immerse or expose to water or other liquids, or expose to fire, explosion, or other hazard.
- Do not leave or store the equipment in or near areas that might get very hot, such as in a parked vehicle or near a radiator or other heat source. Do not place battery into a microwave oven or dryer.
- Battery usage by children should be supervised.
- Please follow local regulations to properly dispose of used re-chargeable batteries.
- Do not dispose of batteries in fire.
- In the event of a battery leak, do not allow the liquid to come in contact with the skin or eyes. If contact has been made, wash the affected area with large amounts of water and seek medical advice.
- If you suspect damage to your equipment or battery, contact Motorola Enterprise Mobility support to arrange for inspection.

Cleaning



CAUTION Always wear eye protection.

Read warning label on compressed air and alcohol product before using.

If you have to use any other solution for medical reasons please contact Motorola for more information.



WARNING! Avoid exposing this product to contact with hot oil or other flammable liquids. If such exposure occurs, unplug the device and clean the product immediately in accordance with these guidelines.

Materials Required

- Alcohol wipes
- Lens tissue
- Cotton tipped applicators
- Isopropyl alcohol
- Can of compressed air with a tube.

Cleaning the MC31XX

Housing

Using the alcohol wipes, wipe the housing including keys and in-between keys.

Display

The display can be wiped down with the alcohol wipes, but care should be taken not to allow any pooling of liquid around the edges of the display. Immediately dry the display with a soft, non-abrasive cloth to prevent streaking.

Scanner Exit Window

Wipe the scanner exit window periodically with a lens tissue or other material suitable for cleaning optical material such as eyeglasses.

Connector

1. Remove the main battery from mobile computer. See *Replacing the Battery on page 1-8*.
2. Dip the cotton portion of the cotton tipped applicator in isopropyl alcohol.
3. Rub the cotton portion of the cotton tipped applicator back-and-forth across the connector on the bottom of the MC31XX. Do not leave any cotton residue on the connector.
4. Repeat at least three times.
5. Use the cotton tipped applicator dipped in alcohol to remove any grease and dirt near the connector area.
6. Use a dry cotton tipped applicator and repeat steps 4 through 6.

7. Spray compressed air on the connector area by pointing the tube/nozzle about ½ inch away from the surface. CAUTION: Do not point nozzle at yourself and others, ensure the nozzle or tube is away from your face.
8. Inspect the area for any grease or dirt, repeat if required.

Cleaning Cradle Connectors

To clean the connectors on a cradle:

1. Remove the DC power cable from the cradle.
2. Dip the cotton portion of the cotton tipped applicator in isopropyl alcohol.
3. Rub the cotton portion of the cotton tipped applicator along the pins of the connector. Slowly move the applicator back-and-forth from one side of the connector to the other. Do not let any cotton residue on the connector.
4. All sides of the connector should also be rubbed with the cotton tipped applicator.
5. Spray compressed air in the connector area by pointing the tube/nozzle about ½ inch away from the surface. CAUTION: do not point nozzle at yourself and others, ensure the nozzle or tube is pointed away from your face.
6. Ensure that there is no lint left by the cotton tipped applicator, remove lint if found.
7. If grease and other dirt can be found on other areas of the cradle, use lint free cloth and alcohol to remove.
8. Allow at least 10 to 30 minutes (depending on ambient temperature and humidity) for the alcohol to air dry before applying power to cradle.

If the temperature is low and humidity is high, longer drying time is required. Warm temperature and dry humidity requires less drying time.

Cleaning Frequency

The cleaning frequency is up to the customer's discretion due to the varied environments in which the mobile devices are used. They may be cleaned as frequently as required. However when used in dirty environments it may be advisable to periodically clean the scanner exit window to ensure optimum scanning performance.

Troubleshooting

Mobile Computer

Table 5-1 Troubleshooting the Mobile Computer

Problem	Cause	Solution
Mobile computer does not turn on.	Main battery not charged.	Charge or replace the main battery.
	Main battery not installed properly.	Ensure the battery is installed properly. See <i>Install Main Battery on page 1-6</i> .
	System crash.	Perform a warm boot. If the mobile computer still does not turn on, perform a cold boot. For more information see, <i>Resetting the Mobile Computer on page 2-26</i> .
Battery did not charge.	Battery failed.	Replace battery. If the mobile computer still does not operate, try a warm boot, then a cold boot. For more information see, <i>Resetting the Mobile Computer on page 2-26</i> .
	Mobile computer removed from cradle while battery was charging.	Insert mobile computer in cradle and begin charging. The Standard Battery requires up to four hours to recharge fully and the Extended Life Battery requires up to six hours to recharge fully.
	Extreme battery temperature.	Battery does not charge if ambient temperature is below 32°F (0°C) or above 104°F (40°C).
Cannot see characters on screen.	Mobile computer not powered on.	Press the Power button.
During data communication, no data was transmitted, or transmitted data was incomplete.	Mobile computer removed from cradle or unplugged from host computer during communication.	Replace the mobile computer in the cradle, or reattach the cable and re-transmit.
	Incorrect cable configuration.	See the system administrator or refer to the <i>MC31XX Series Mobile Computer Integrator Guide</i> .
	Communication software was incorrectly installed or configured.	See the system administrator or refer to the <i>MC31XX Series Mobile Computer Integrator Guide</i> .
Mobile computer does not emit sound.	Volume setting is low or turned off.	Mobile computer may be a beeper only configuration or incorrect setting is programmed into device.

Table 5-1 Troubleshooting the Mobile Computer (Continued)

Problem	Cause	Solution
Mobile computer turns itself off.	Mobile computer is inactive.	The mobile computer turns off after a period of inactivity. This period can be set from one to five minutes, in one-minute intervals.
	Battery is depleted.	Recharge or replace the battery.
	Battery is not inserted properly.	Insert the battery properly. For more information see, <i>Install Main Battery on page 1-6</i> .
Tapping the window buttons or icons does not activate the corresponding feature.	Touch screen not calibrated correctly.	Re-calibrate the screen. From the mobile computer, <i>Demo window</i> double-tap the <i>Ctl Panel</i> icon and double-tap on <i>Touch Calibrate</i> . Follow the screen prompts.
	The system crashed.	Warm boot the system. To perform a warm boot, see <i>Resetting the Mobile Computer on page 2-26</i> .
A message appears stating that the mobile computer memory is full.	Too many files stored on the mobile computer.	Delete unused memos and records. If necessary, save these records on the host computer.
	Too many applications installed on the mobile computer.	Remove unused installed applications from the mobile computer to recover memory.
The mobile computer does not accept scan input.	Scanning application is not loaded.	Verify that the mobile computer is loaded with a scanning application. See the system administrator.
	Unreadable bar code.	Ensure the symbol is not defaced.
	Distance between scan window and bar code is incorrect.	Ensure the mobile computer is within proper scanning range.
	Mobile computer is not programmed for the bar code type.	Ensure the mobile computer is programmed to accept the type of bar code scanned.
	Mobile computer is not programmed to generate a beep.	If a beep on a good decode is expected and a beep is not heard, check that the application is set to generate a beep on good decode.
	Battery is low.	Check the battery level. When the battery is low, the mobile computer automatically goes into suspend mode.

Single Slot Serial/USB Cradle

Table 5-2 Troubleshooting the Single Slot Serial/USB Cradle

Symptom	Possible Cause	Solution
Mobile computer amber Charge LED Indicator does not light when mobile computer inserted.	Cradle is not receiving power.	Ensure the power cable is connected securely to both the cradle and to AC power.
	Mobile computer is not correctly seated.	Remove and re-insert the mobile computer into the cradle, ensuring it is correctly seated.
Spare Battery Charging LED does not light when spare battery is inserted.	Spare battery is not correctly seated.	Remove and re-insert the spare battery into the charging slot, ensuring it is correctly seated.
Mobile computer battery is not charging.	Mobile computer was removed from cradle or cradle was unplugged from AC power too soon.	Ensure cradle is receiving power. Ensure the mobile computer is seated correctly. If the mobile computer battery is fully depleted, it can take up to four hours to fully recharge a Standard Battery and it can take up to six hours to fully recharge an Extended Life Battery.
	Battery is faulty.	Verify that other batteries charge properly. If so, replace the faulty battery.
	The mobile computer is not fully seated in the cradle.	Remove and re-insert the mobile computer into the cradle, ensuring it is correctly seated.
Spare battery is not charging.	Battery not fully seated in charging slot.	Remove and re-insert the spare battery into the cradle, ensuring it is correctly seated.
	Battery inserted incorrectly.	Ensure the contacts are facing down and toward the back of the cradle.
	Battery is faulty.	Verify that other batteries charge properly. If so, replace the faulty battery.
During data communication, no data was transmitted, or transmitted data was incomplete.	Mobile computer removed from cradle during communication.	Replace mobile computer in cradle and retransmit.
	Incorrect cable configuration.	See the system administrator or refer to the <i>MC31XX Series Mobile Computer Integrator Guide</i> .
	Communication software is not installed or configured properly.	See the system administrator or refer to the <i>MC31XX Series Mobile Computer Integrator Guide</i> .

Four Slot Charge Only Cradle

Table 5-3 Troubleshooting the Four Slot Charge Only Cradle

Problem	Cause	Solution
Mobile computer amber Charge LED Indicator does not light when mobile computer inserted.	Cradle is not receiving power.	Ensure the power cable is connected securely to both the cradle and to AC power.
	Mobile computer is not correctly seated.	Remove and re-insert the mobile computer into the cradle, ensuring it is correctly seated.
Mobile computer battery is not charging.	Mobile computer was removed from cradle or cradle was unplugged from AC power too soon.	Ensure cradle is receiving power. Ensure the mobile computer is seated correctly. If the mobile computer battery is fully depleted, it can take up to four hours to fully recharge a Standard Battery and it can take up to six hours to fully recharge an Extended Life Battery.
	Battery is faulty.	Verify that other batteries charge properly. If so, replace the faulty battery.
	The mobile computer is not fully seated in the cradle.	Remove and re-insert the mobile computer into the cradle, ensuring it is correctly seated.

Four Slot Ethernet Cradle

Table 5-4 Troubleshooting the Four Slot Ethernet Cradle

Problem	Cause	Solution
Mobile computer amber Charge LED Indicator does not light when mobile computer inserted.	Cradle is not receiving power.	Ensure the power cable is connected securely to both the cradle and to AC power.
	Mobile computer is not correctly seated.	Remove and re-insert the mobile computer into the cradle, ensuring it is correctly seated.
Mobile computer battery is not charging.	Mobile computer was removed from cradle or cradle was unplugged from AC power too soon.	Ensure cradle is receiving power. Ensure the mobile computer is seated correctly. If the mobile computer battery is fully depleted, it can take up to four hours to fully recharge a Standard Battery and it can take up to six hours to fully recharge an Extended Life Battery.
	Battery is faulty.	Verify that other batteries charge properly. If so, replace the faulty battery.
	The mobile computer is not fully seated in the cradle.	Remove and re-insert the mobile computer into the cradle, ensuring it is correctly seated.

Table 5-4 Troubleshooting the Four Slot Ethernet Cradle (Continued)

Problem	Cause	Solution
During data communication, no data was transmitted, or transmitted data was incomplete.	Mobile computer removed from cradle during communication.	Replace mobile computer in cradle and retransmit.
	Incorrect cable configuration.	See the system administrator or refer to the <i>MC31XX Series Mobile Computer Integrator Guide</i> .
	Ethernet connection error. Link LED is not lit (see <i>Link LED on page 4-7</i>).	See the system administrator. Probable Ethernet connection error.

Four Slot Spare Battery Charger

Table 5-5 Troubleshooting the Four Slot Spare Battery Charger

Symptom	Possible Cause	Solution
Spare Battery Charging LED does not light when spare battery is inserted.	Spare battery is not correctly seated.	Remove and re-insert the spare battery into the charging slot, ensuring it is correctly seated.
Spare battery is not charging.	Charger is not receiving power.	Ensure the power cable is connected securely to both the charger and to AC power.
	Spare battery is not correctly seated.	Remove and re-insert the battery into the charger, ensuring it is correctly seated.
	Spare battery was removed from charger or charger was unplugged from AC power too soon.	Ensure charger is receiving power. Ensure the spare battery is seated correctly. If a battery is fully depleted, it can take up to four hours to fully recharge a Standard Battery and it can take up to six hours to fully recharge an Extended Life Battery.
	Spare battery is faulty.	Verify that other batteries charge properly. If so, replace the faulty battery.

UBC Adapter

Table 5-6 Troubleshooting the UBC Adapter

Symptom	Possible Cause	Solution
Battery Charging LED does not light when spare battery is inserted.	Spare battery is not correctly seated.	Remove and re-insert the spare battery into the charging slot, ensuring it is correctly seated.
Battery not charging.	Charger is not receiving power.	Ensure the power cable is connected securely to both the charger and to AC power.
	Spare battery is not correctly seated.	Remove and re-insert the spare battery into the charger, ensuring it is correctly seated.
	Spare battery was removed from charger or charger was unplugged from AC power too soon.	Ensure charger is receiving power. Ensure the spare battery is seated correctly. If a battery is fully depleted, it can take up to four hours to fully recharge a Standard Battery and it can take up to six hours to fully recharge an Extended Life Battery.
	Spare battery is faulty.	Verify that other batteries charge properly. If so, replace the faulty battery.

Cables

Table 5-7 Troubleshooting the Cables

Symptom	Possible Cause	Solution
Mobile computer amber Charge LED Indicator does not light when mobile computer attached.	Cable is not receiving power.	Ensure the power cable is connected securely to both the cable and to AC power.
	Mobile computer is not seated correctly in the cable.	Remove and re-attach the mobile computer to the MC31XX connector, ensuring it is correctly seated.
Mobile computer battery is not charging.	Mobile computer was detached from cable or cable was unplugged from AC power too soon.	Ensure cable is receiving power. Ensure the mobile computer is seated correctly. If the mobile computer battery is fully depleted, it can take up to four hours to fully recharge a Standard Battery and it can take up to six hours to fully recharge an Extended Life Battery.
	Battery is faulty.	Verify that other batteries charge properly. If so, replace the faulty battery.
	The mobile computer is not fully seated in the cable.	Remove and re-attach the mobile computer to the cable, ensuring it is correctly seated.

Table 5-7 Troubleshooting the Cables (Continued)

Symptom	Possible Cause	Solution
During data communication, no data was transmitted, or transmitted data was incomplete.	Cable removed from mobile computer during communication.	Reattach cable to mobile computer and retransmit.
	Incorrect cable configuration.	See the system administrator or refer to the <i>MC31XX Series Mobile Computer Integrator Guide</i> .
	Communication software is not installed or configured properly.	See the system administrator or refer to the <i>MC31XX Series Mobile Computer Integrator Guide</i> .

Appendix A Technical Specifications

Mobile Computer and Accessory Technical Specifications

[Table A-1](#) summarizes the mobile computer technical specifications and intended operating environments.

[Table A-2](#) summarizes the accessory technical specifications and the intended operating environments.

Table A-1 MC31XX Technical Specifications

Item	Description
Physical Characteristics	
Dimensions	<p>MC31XXS: 7.45 in L x 3.25 in W x 1.77 in D (190.4 mm L x 82.6 mm W x 45.2 mm D) At grip: 2.40 in. W x 1.44 in. D/61.2 mm x 36.8 mm</p> <p>MC31XXR: 8.36 in L x 3.25 in W x 1.57 in D (212.5 mm L x 82.6 mm W x 39.9 mm D) At grip: 2.40 in. W x 1.14 in. D/61.2 mm x 29 mm</p> <p>MC3190G: 7.5 in L x 3.1 in W x 6.5 in D (193 mm L x 80.8 mm W x 166 mm H)</p>
Weight (including battery, stylus, and handstrap)	<p>MC31XXR (with standard battery)* - 13.4 oz (380 g) MC31XXS (with extended battery)* - 14.8 oz (420 g) MC3190G (with extended battery)* - 18.34 oz (520 g)</p>
Display	3.0 inch Color (TFT) (320 x 320) Display with backlight
Touch Panel	Polycarbonate analog resistive touch
Backlight	LED backlight

Table A-1 MC31XX Technical Specifications (Continued)

Item	Description
Battery	Standard: Rechargeable Lithium-Ion 2740 mAh(3.7V) (for MC31XXR) Extended Life: Rechargeable Lithium-Ion 4400 mAh(3.7V)(for MC31XXS,MC3190G)
Expansion Slot	User accessible (located under battery); approved for memory expansion only
Network Connections	High-speed USB client, full-speed USB host, Bluetooth and WiFi. USB host mode available with appropriate cables only.
Notification	Programmable LEDs; Audio notifications
Keypad Options	28-key Numeric Telephony 38-key Shifted Alpha (calculator-style integrated numeric keypad) 48-key Alpha-Numeric (calculator-style integrated numeric keypad)
Audio	Speaker, receiver, microphone, software support for full duplex capability, Bluetooth stereo.
Performance Characteristics	
CPU	Marvell PXA320 processor at 624 MHz
Operating System	Microsoft® Windows CE .NET 6.0 Professional Microsoft® Windows Mobile 6.1 Classic
Memory	128 MB RAM/256MB Flash or 128 MB RAM/512 MB Flash
Output Power	USB: 5 VDC @ 200 mA max.
User Environment	
Operating Temperature	-20°C to 50°C (-4°F to 122°F)
Storage Temperature	-20° to 50°C (-4° to 122°F)
Charging Temperature	0° C to 40° C (32°F to 104°F)
Humidity	95% non-condensing
Drop Specification	Meets and exceeds MIL-STD 810F drop specifications: 4 ft./1.2 m drop to concrete across the operating temperature range
Tumble	500 1.64 ft./0.5 m tumbles (1,000 drops) at room temperature; meets and exceeds applicable MIL-STD 810F tumble specifications
Electrostatic Discharge (ESD)	+/-15 kV air discharge +/- 8 kV direct discharge +/- 8 kV indirect discharge
Sealing	IP54 category 2

Table A-1 MC31XX Technical Specifications (Continued)

Item	Description
Wireless LAN Data and Voice Communications	
Wireless Local Area Network (WLAN) radio	Tri-mode IEEE® 802.11a/b/g
Data Rates Supported	1, 2, 5.5, 6, 9, 11, 12, 18, 24, 36, 48, and 54 Mbps
Operating Channels	Chan 1-13 (2412-2472 MHz), Chan 14 (2484 MHz) Japan only; actual operating channels/frequencies depend on regulatory rules and certification agency
Security	WPA2 (Personal or Enterprise); 802.1x; EAP-TLS; TTLS (CHAP, MS-CHAP, MS-CHAPv2, PAP or MD5); PEAP (TLS, MSCHAPv2, EAP-GTC); LEAP, EAP-FAST (TLS, MS-CHAPv2, EAP-GTC); CCXv4 certified; support for IPv6; FIPS140-2 Certified
Spreading Technique	Direct Sequence Spread Spectrum (DSSS) and Orthogonal Frequency Division Multiplexing (OFDM)
Antenna	Internal antenna w/diversity
Voice Communication	Voice-over-IP ready, Wi-Fi™-certified, IEEE 802.11a/b/g direct sequence wireless LAN, Wi-Fi Multimedia™ (WMM), Motorola Voice Quality Manager (VQM)
Wireless PAN Data and Voice Communications	
Bluetooth	Class II, v2.1 with Enhanced Data Rate (EDR); integrated antenna
Regulatory	
Electrical Safety	Certified to UL60950, CSA C22.2No. 60950, EN60950/IEC 950
Environmental	RoHS-compliant
WLAN and Bluetooth (PAN)	USA: FCC Part 15.247, 15.407 Canada: RSS-210 EU: EN 300 328, EN 301 893 Japan: ARIB STD T33, T66, T70, T71 Australia: AS/NZS 4268s
RF Exposure	USA: FCC Part 2, FCC OET Bulletin 65 Supplement C Canada: RSS-102 EU: EN 50360 Australia: Radio communications Standard 2003
EMI/RFI Radio Version	North America: FCC Part 2 (SAR), FCC Part 15, RSS210 Class B, EN 301 489-1, 489-17

Table A-1 MC31XX Technical Specifications (Continued)

Item	Description
EMI/RFI Batch Version	North America: FCC Part 15, ICES 003 Class B EU: EN55022 Class B EN55024 Japan: CISPR 22, Class B Australia: AS3548
Laser Safety	IEC Class2/FDA Class II in accordance with IEC60825-1/EN60825-1
Data Capture Specifications	
Options	1D laser scanner 2D imager
Linear 1D Scanner (SE950) Specifications	
Optical Resolution	0.004 in. minimum element width
Roll	+/- 35° from vertical
Pitch Angle	+/- 65° from normal
Skew Tolerance	+/- 50° from normal
Ambient Light	10,000 ft. candles/107,640 lux
Scan Rate	104 (+/- 12) scans/sec (bidirectional)
Scan Angle	47° ± 3° default; configurable narrow angle: 35° ± 3°
2D Imager Engine (SE4500) Specifications	
Field of View	Horizontal - 32.2° Vertical - 24.5°
Optical Resolution	752 x 480 pixels
Roll	360°
Pitch Angle	+/- 60° from normal
Skew Tolerance	+/- 60° from normal
Ambient Light	9,000 ft. candles (96,900 Lux)
Focal Distance from Front of Engine	Near: 1.6 inches Far: 15 inches
Aiming Element (VLD)	655 nm +/- 10 nm
Illumination Element (LED)	625 nm +/- 5 nm
Motorola Interactive Sensor Technology	
Motion-sensor	3-axis accelerometer that enables motion-sensing applications on dynamic screen orientation, power management and free-fall detects

Table A-2 Accessory Specifications

	Single Slot Serial/USB Cradle	Cables	Four Slot Charge Only and Ethernet Cradles	Four Slot Spare Battery Charger	Universal Battery Charger (UBC) Adapter
Operating Temperature	32° to 122°F (0° to +50°C)			32° to 104°F (0° to +40°C)	
Storage Temperature	-40° to 158°F (-40° to 70°C)				
Battery Charging Temperature	32° to 104° F (0° to +40° C) ambient temperature				
Humidity	5% to 95% non-condensing				
Size (L x D x H)	4.4 in x 5.7 in x 4.7 in (11.2 cm x 14.5 cm x 12 cm)	6 feet (1.83 m)	18 in x 4 in x 5 in (45.7 cm x 10.1 cm x 12 cm)	8.25 in x 6.0 in x 1.7 in (20.96 cm x 15.24 cm x 4.32 cm)	2.5 in x 6.1 in x 1.5 in (6.4 cm x 15.5 cm x 3.8 cm)
Weight	0.60 lbs (0.27 kg)	N/A	Charge only: 2.25 lbs (1.02 kg) Ethernet: 2.38 lbs (1.08 kg)	13.6 oz (386 g)	0.25 lbs (0.11 kg)
Power	12V, 3.3 A	5.4V, 3 A	12V, 9 A	12V, 3.3 A	15V, 1.5 A
Drop	30 inches (76.2 centimeter) to vinyl covered concrete				
Electrostatic Discharge (ESD)	+/-15 kV air discharge, +/- 8 kV direct discharge, +/- 8 kV indirect discharge				

Preliminary

Appendix B Keypads

Introduction

The mobile computer is available with the following keypad configurations:

- 28-key keypad
- 38-key keypad
- 48-key keypad.

✓ **NOTE** For information about using the soft keyboard input panel. For more information, see *Entering Information Using the Keyboard Input Panel* on page 2-15.

28-Key Keypad

The 28-key keypad contains a **Power** button, application keys, scroll keys and function keys. The keypad is color-coded to indicate the alternate function key (blue) values and the alternate **ALPHA** key (orange) values. Note that keypad functions can be changed by an application so the mobile computer keypad may not function as described. See [Table B-1 on page B-2](#) for key and button descriptions and [Table B-8 on page B-14](#) for the keypad special functions.



Figure B-1 28-Key Keypad

Table B-1 28-Key Descriptions





Key	Description
Power (red) 	Powers the mobile computer screen on and off (resume and suspend).
Green Circle 	Programmable application function key by default.
Red Circle 	Programmable application function key by default.
Scan (yellow) 	Used in scanning applications, press to scan a bar code. This key has the same function as activating the side mounted scan buttons.

Table B-1 28-Key Descriptions (Continued)











Key	Description
Scroll Up and Down 	Moves up and down from one item to another. Increases/decreases specified values.
Scroll Left and Right 	Moves left and right from one item to another. Increases/decreases specified values. Produces a TAB when the blue FUNC key is activated and the right arrow key is pressed.
ESC 	Produces the ESC function by default.
CTRL 	Press and release the CTRL key to activate the keypad alternate CTRL functions. The  icon appears on the taskbar on WinCE devices or the  icon appears at the bottom of the screen on Windows Mobile 6.1 devices. Press and release the CTRL key again to return to the default keypad functions.
Numeric/Alpha/Special Function 	<p>Numeric, alpha or special function keys. Numeric by default.</p> <p>Produces a special function when the blue FUNC key is activated.</p> <p>Produces alpha values when the orange ALPHA key is activated.</p> <p>In Alpha state, produces the lower case alphabetic characters on the key. Each key press produces the next alphabetic character in sequence. For example, press and release the ALPHA key and then press the 4 key once to produce the letter 'g'; press and release the ALPHA key and then press the 4 key three times to produce the letter 'i'.</p> <p>When the SHIFT key is pressed in Alpha state, the upper case alphabetic characters on the key are produced. For example, press and release the ALPHA key, press and hold the SHIFT key and then press the 4 key once to produce the letter 'G'; press and release the ALPHA key, press and hold the SHIFT key and then press the 4 key three times to produce the letter 'I'.</p>
Period/Decimal Point 	<p>Produces a period for alpha entries and a decimal point for numeric entries by default.</p> <p>Produces the F10 function when the blue FUNC key is activated.</p>
Enter 	Executes a selected item or function.
BKSP 	BKSP , backspace function by default.
SPACE 	SPACE , space function by default.

Table B-1 28-Key Descriptions (Continued)











Key	Description
Shift 	Press and release the SHIFT key to activate the keypad alternate SHIFT functions. The  icon appears on the taskbar on WinCE devices and the  icon appears at the bottom of the screen on Windows Mobile 6.1 devices. Press and release the SHIFT key again to return to the default keypad functions.
ALPHA (orange) 	Press the orange ALPHA key to access the alternate ALPHA characters (shown on the keypad in orange). The  icon appears on the taskbar on WinCE devices and the  icon appears at the bottom of the screen on Windows Mobile 6.1 devices. Press and release the orange ALPHA key again to return to the default keypad functions.
FUNC (blue) 	Press and release the blue FUNC key to activate the keypad alternate functions (shown on the keypad in blue). The  icon appears on the taskbar on WinCE devices or the  icon appears at the bottom of the screen on Windows Mobile 6.1 devices. Press and release the blue FUNC key again to return to the default keypad functions.
Display backlight 	Toggles the display backlight on and off.

Table B-2 28 Key Keypad Input Modes

Key	Numeric Mode		Orange Key (Alpha Lowercase Mode)				Orange + Shift Keys (Alpha Uppercase Mode)			
		SHIFT + Key	1st Press	2nd Press	3rd Press	4th Press	1st Press	2nd Press	3rd Press	4th Press
1	1	!	@	?			@	?		
2	2	@	a	b	c		A	B	C	
3	3	#	d	e	f		D	E	F	
4	4	\$	g	h	i		G	H	I	
5	5	%	j	k	l		J	K	L	
6	6	^	m	n	o		M	N	O	
7	7	&	p	q	r	s	P	Q	R	S
8	8	*	t	u	v		T	U	V	
9	9	(w	x	y	z	W	X	Y	Z
0	0)	.au				au			
,	,	<	,				,			

Note: An application can change the key functions. The keypad may not function exactly as described.

Table B-2 28 Key Keypad Input Modes (Continued)

Key	Numeric Mode		Orange Key (Alpha Lowercase Mode)				Orange + Shift Keys (Alpha Uppercase Mode)			
		SHIFT + Key	1st Press	2nd Press	3rd Press	4th Press	1st Press	2nd Press	3rd Press	4th Press
.	.	>	.				.			
*	*	*	*				*			
-	-	—	-				—			

Note: An application can change the key functions. The keypad may not function exactly as described.

38-Key Keypad

The 38-key keypad contains a **Power** button, application keys, scroll keys and function keys. The keypad is color-coded to indicate the alternate function key (blue) values. Note that keypad functions can be changed by an application so the mobile computer keypad may not function as described. See [Table B-3 on page B-6](#) for key and button descriptions and [Table B-8 on page B-14](#) for the keypad special functions.



Figure B-2 38-Key Keypad

Table B-3 38-Key Descriptions



Key	Description
Power (red) 	Powers the mobile computer screen on and off (resume and suspend).
Green Circle 	Programmable application function key by default.
Red Circle 	Programmable application function key.

Table B-3 38-Key Descriptions (Continued)

















Key	Description
Scan (yellow) 	Used in scanning applications, press to scan a bar code.
Scroll Left and Right 	Moves left and right from one item to another by default. Produces a TAB when the blue FUNC key is activated and the right arrow key is pressed.
Scroll Up and Down 	Moves up and down from one item to another by default.
ALPHA (orange) 	Press the orange ALPHA key to access the alternate ALPHA characters (shown on the keypad in orange). The ALP icon appears on the taskbar on WinCE devices and the  icon appears at the bottom of the screen on Windows Mobile 6.1 devices. Press and release the orange ALPHA key again to return to the default keypad functions.
CTRL 	Press and release the CTRL key to activate the keypad alternate CTRL functions. The  icon appears on the taskbar on WinCE devices or the  icon appears at the bottom of the screen on Windows Mobile 6.1 devices. Press and release the CTRL key again to return to the default keypad functions.
CLEAR 	Clears inputs.
FUNC (blue) 	Press and release the blue FUNC key to activate the keypad alternate functions (shown on the keypad in blue). The F icon appears on the taskbar on WinCE devices or the  icon appears at the bottom of the screen on Windows Mobile 6.1 devices. Press and release the blue FUNC key again to return to the default keypad functions.
Numeric/Alpha/Special Function 	Press for the default numeric value. Produces alpha values when the orange ALPHA key is activated.
BKSP/SPACE 	BKSP , backspace function by default. Produces the SPACE function when the orange ALPHA key is activated.
SHIFT 	Press and release the SHIFT key to activate the keypad alternate SHIFT functions. The  icon appears on the taskbar on WinCE devices and the  icon appears at the bottom of the screen on Windows Mobile 6.1 devices. Press and release the SHIFT key again to return to the default keypad functions.
Enter 	Executes a selected item or function.

Table B-3 38-Key Descriptions (Continued)





Key	Description
Period/Decimal Point 	Produces a period for alpha entries and a decimal point for numeric entries. Produces alpha values when the orange ALPHA key is activated.
Comma 	Produces a comma by default. Produces alpha values when the orange ALPHA key is activated.
Special Function/Alpha 	Special function by default or when the blue FUNC key is activated. Produces alpha values when the orange ALPHA key is activated.
Display backlight 	Toggles the display backlight on and off.

Table B-4 Telephony Numeric Keypad Input Modes

Key	Numeric Mode		Orange Key (Alpha Lowercase Mode)				Orange + Shift Keys (Alpha Uppercase Mode)			
		SHIFT+ Key	1st Press	2nd Press	3rd Press	4th Press	1st Press	2nd Press	3rd Press	4th Press
1	1	!	@	?			@	?		
2	2	@	a	b	c		A	B	C	
3	3	#	d	e	f		D	E	F	
4	4	\$	g	h	i		G	H	I	
5	5	%	j	k	l		J	K	L	
6	6	^	m	n	o		M	N	O	
7	7	&	p	q	r	s	P	Q	R	S
8	8	*	t	u	v		T	U	V	
9	9	(w	x	y	z	W	X	Y	Z
0	0)	.au				au			
,	,	<	,				,			
.	.	>	.				.			
*	*	*	*				*			
-	-	-	-				-			

Note: An application can change the key functions. The keypad may not function exactly as described.

48-Key Keypad

The 48-key keypad contains a **Power** button, application keys, scroll keys and function keys. The keypad is color-coded to indicate the alternate function key (blue) values. Note, that keypad functions can be changed by an application so the mobile computer keypad may not function as described. See [Table B-3 on page B-6](#) for key and button descriptions and [Table B-8 on page B-14](#) for the keypad special functions.

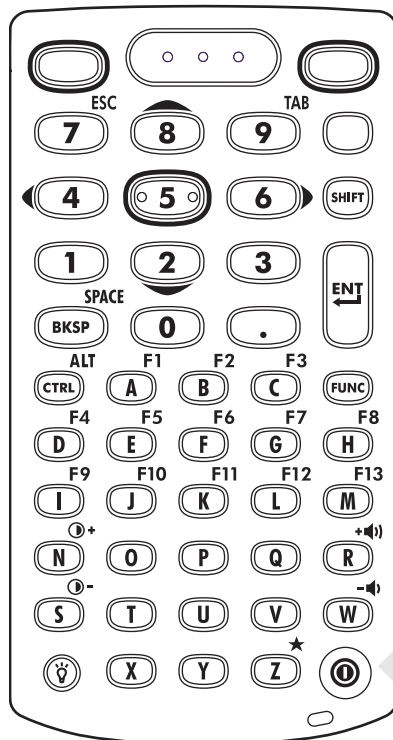

Figure B-3 48-Key Keypad

Table B-5 48-Key Descriptions























Key	Description
Power (red) ①	Powers the mobile computer screen on and off (resume and suspend).
Green Circle 	Unassigned application function key by default.
Red Circle 	Unassigned application function key.
Scan (yellow) 	Scan key, used for scanning applications.

Table B-5 48-Key Descriptions (Continued)

Key	Description
Orange 	Press the orange key to access the alternate navigation and selection functions. The ALP icon appears on the taskbar on WinCE devices and the  icon appears at the bottom of the screen on Windows Mobile 6.1 devices. Press and release the orange key again to return to the default keypad functions.
Numeric/Scroll/Select 	Numeric, scroll, select keys. Numeric by default. With the orange key activated, the 2 , 4 , 6 , and 8 keys produce scroll functions and the 5 key produces a select function. With the FUNC key activated, 7 produces the ESC function and 9 produces the TAB function.
Shift 	Press and release the SHIFT key to activate the keypad alternate SHIFT functions. The  icon appears on the taskbar on WinCE devices and the  icon appears at the bottom of the screen on Windows Mobile 6.1 device. Press and release the SHIFT key again to return to the default keypad functions.
Enter 	Executes a selected item or function.
BKSP/SPACE 	BKSP , backspace function by default. Produces the SPACE function when the blue FUNC key is activated.
Period/Decimal Point 	Produces a period for alpha entries and a decimal point for numeric entries.
Control 	Press and release the CTRL key to activate the keypad alternate CTRL functions. The  icon appears on the taskbar on WinCE devices or the  icon appears at the bottom of the screen on Windows Mobile 6.1 devices. Press and release the CTRL key again to return to the default keypad functions. Press and release the blue FUNC key and then the CTRL key to activate the ALT functions. The  icon appears on the taskbar on WinCE devices or the  icon appears at the bottom of the screen on Windows Mobile 6.1 devices. Press and release the CTRL key two times to return to the default keypad functions.
Alpha/Special Function 	Alpha by default. Special function by default when the blue FUNC key is activated.
FUNC (blue) 	Press and release the blue FUNC function key to activate the keypad alternate functions (shown on the keypad in blue). The  icon appears on the taskbar on WinCE devices or the  icon appears at the bottom of the screen on Windows Mobile 6.1 devices. Press and release the blue FUNC function key again to return to the default keypad functions.
Display Backlight 	Toggles the display backlight on and off.

The MC95XX offers four types modular keypad configurations:

- Alpha Primary
- Alpha Numeric Wide
- Calculator Numeric
- Telephony Numeric.

Table B-6 Alpha Primary Keypad Input Modes

Key	Normal	Shift + Key	Orange + Key
A	a	A	
B	b	B	1
C	c	C	2
D	d	D	3
E	e	E	
F	f	F	4
G	g	G	5
H	h	H	6
I	i	I	
J	j	J	7
K	k	K	8
L	l	L	9
M	m	M	
N	n	N	*
O	o	O	0
P	p	P	#
Q	q	Q	
R	r	R	au
S	s	S	@
T	t	T	/
U	u	T	?
V	v	V	
W	w	W	
X	x	X	

Note: An application can change the key functions. The keypad may not function exactly as described.

Table B-6 *Alpha Primary Keypad Input Modes (Continued)*





Key	Normal	Shift + Key	Orange + Key
Y	y	Y	
Z	z	Z	
ENTER	Enter	Enter	Enter
TAB	Tab	Tab	Back tab
SPACE	Space	Space	Space
BKSP	Backspace	Backspace	Backspace

Note: An application can change the key functions. The keypad may not function exactly as described.

Keypad Special Functions

The keypad special functions are color coded on the keypads. For example, on the 38-key keypad, the display contrast icon is blue indicating that the blue function key must be selected first along with the F6 key, to increase the display contrast.

Table B-7 Keypad Special Functions

Icon	28-Key Keystrokes	38-Key Keystrokes	48-Key Keystrokes	Special Function
	Blue function key and period .	Blue function key and F6	Blue function key and N	Increases display contrast setting, darkens the display (on monochrome units only).
	Blue function key and BKSP .	Blue function key and F9	Blue function key and S	Decreases display contrast setting, lightens the display (on monochrome units only).
	Blue function key and the up arrow.	Blue function key and F7	Blue function key and R	Increases scan decode beeper volume.
	Blue function key and down arrow.	Blue function key and F10	Blue function key and W	Decreases scan decode beeper volume.

✓ **NOTE** Mobile computers with color screens do not have contrast settings.

Keypads

The mobile computer is available with one of three keypads:

- 28-key keypad
- 38-key keypad
- 48-key keypad.

The keypads can be selected as necessary to support specialized applications. The 28, 38 and 48-key keypads contain a **Power** button, application keys, scroll keys and function keys. The keypads are color-coded to indicate the alternate function key (blue) values and the alternate ALPHA key (orange) values. See [Table B-8](#) for the special character generation. Characters can also be generated using the keyboard input panel. For more information see, *Entering Information Using the Keyboard Input Panel on page 2-15*.

Table B-8 Special Character Generation Map

Special Character	28-Key Keypad Key Sequence, Special Character Generation	38-Key Keypad Key Sequence, Special Character Generation	48-Key Keypad Key Sequence, Special Character Generation
[Use the Keyboard Input Panel*	FUNC + 4	FUNC + T
]	Use the Keyboard Input Panel*	FUNC + 5	FUNC + U
/	Use the Keyboard Input Panel*	FUNC + 9	FUNC + Q
\	Use the Keyboard Input Panel*	FUNC + 3	Use the Keyboard Input Panel*
=	Use the Keyboard Input Panel*	FUNC + 8	FUNC + P
;	Use the Keyboard Input Panel*	FUNC + 6	FUNC + V
-	Use the Keyboard Input Panel*	FUNC + 7	FUNC + O
`	Use the Keyboard Input Panel*	FUNC + 2	FUNC + Y
“	Use the Keyboard Input Panel*	SHIFT + FUNC + 1	Use the Keyboard Input Panel*
!	SHIFT + 1	SHIFT + 1	SHIFT + 1
@	SHIFT + 2	SHIFT + 2	SHIFT + 2
#	SHIFT + 3	SHIFT + 3	SHIFT + 3
\$	SHIFT + 4	SHIFT + 4	SHIFT + 4
%	SHIFT + 5	SHIFT + 5	SHIFT + 5
^	SHIFT + 6	SHIFT + 6	SHIFT + 6
&	SHIFT + 7	SHIFT + 7	SHIFT + 7
*	SHIFT + 8	SHIFT + 8	SHIFT + 8
(SHIFT + 9	SHIFT + 9 or FUNC + SHIFT + 9	SHIFT + 9
)	SHIFT + 0	SHIFT + 0 or FUNC + SHIFT + 0	SHIFT + 0
‘	Use the Keyboard Input Panel*	FUNC + 1	FUNC + X

* See *Entering Information Using the Keyboard Input Panel* on page 2-15.

Table B-8 Special Character Generation Map (Continued)

Special Character	28-Key Keypad Key Sequence, Special Character Generation	38-Key Keypad Key Sequence, Special Character Generation	48-Key Keypad Key Sequence, Special Character Generation
"	Use the Keyboard Input Panel*	Use the Keyboard Input Panel*	Use the Keyboard Input Panel*
+	Use the Keyboard Input Panel*	SHIFT + FUNC + 8	Use the Keyboard Input Panel*
:	Use the Keyboard Input Panel*	SHIFT + FUNC + 6	Use the Keyboard Input Panel*
<	Use the Keyboard Input Panel*	FUNC + SHIFT + ,	Use the Keyboard Input Panel*
>	Use the Keyboard Input Panel*	FUNC + SHIFT + .	SHIFT + .
?	Use the Keyboard Input Panel*	SHIFT + FUNC + 9	Use the Keyboard Input Panel*
_	Use the Keyboard Input Panel*	SHIFT + FUNC + 7	Use the Keyboard Input Panel*
{	Use the Keyboard Input Panel*	SHIFT + FUNC + 4	Use the Keyboard Input Panel*
}	Use the Keyboard Input Panel*	SHIFT + FUNC + 5	Use the Keyboard Input Panel*
~	Use the Keyboard Input Panel*	SHIFT + FUNC + 2	Use the Keyboard Input Panel*
	N/A	SHIFT + FUNC + 3	N/A

* See *Entering Information Using the Keyboard Input Panel* on page 2-15.

Preliminary

Glossary

Numeric

802.11/802.11abg. A radio protocol that may be used by the WLAN radio card.

A

Access Point. Access Point (AP) refers to Motorola's Ethernet Access Point. It is a piece of communications equipment that manages communications between the host computer system and one or more wireless terminals. An AP connects to a wired Ethernet LAN and acts as a bridge between the Ethernet wired network and IEEE 802.11 interoperable radio-equipped mobile units, such as a mobile computer. The AP allows a mobile user to roam freely through a facility while maintaining a seamless connection to the wired network.

AirBEAM® Manager. AirBEAM® Manager is a comprehensive wireless network management system that provides essential functions that are required to configure, monitor, upgrade and troubleshoot the wireless network and its components (including networked mobile computers). Some features include event notification, access point configuration, diagnostics, statistical reports, auto-discovery, wireless proxy agents and monitoring of access points and mobile units.

AirBEAM® Smart Client. AirBEAM® Smart Client is part of Motorola's AirBEAM® suite, which also includes AirBEAM® Safe and AirBEAM® Manager. The AirBEAM® Smart Client system uses the network accessible host server to store software files that are to be downloaded to the mobile computers. The AirBEAM® Smart Client provides the mobile computers with the "smarts" to request software from the host. It allows them to request, download and install software, as well as to upload files and status data. The AirBEAM® Smart Client uses the industry standard FTP or TFTP file transfer protocols to check the host system for updates, and if necessary, to transfer updated software. Most often, AirBEAM® Smart Client is used with wireless networks, but any TCP/IP connection can be used. For more information, refer to the AirBEAM® Smart Windows® CE Client Product Reference Guide (p/n 72-63060-xx).

AP. See **Access Point**.

Aperture. The opening in an optical system defined by a lens or baffle that establishes the field of view.

ASCII. American Standard Code for Information Interchange. A 7 bit-plus-parity code representing 128 letters, numerals, punctuation marks and control characters. It is a standard data transmission code in the U.S.

B

Bar. The dark element in a printed bar code symbol.

Bar Code. A pattern of variable-width bars and spaces which represents numeric or alphanumeric data in machine-readable form. The general format of a bar code symbol consists of a leading margin, start character, data or message character, check character (if any), stop character, and trailing margin. Within this framework, each recognizable symbology uses its own unique format. See **Symbology**.

Bar Code Density. The number of characters represented per unit of measurement (e.g., characters per inch).

Bar Height. The dimension of a bar measured perpendicular to the bar width.

Bar Width. Thickness of a bar measured from the edge closest to the symbol start character to the trailing edge of the same bar.

Bit. Binary digit. One bit is the basic unit of binary information. Generally, eight consecutive bits compose one byte of data. The pattern of 0 and 1 values within the byte determines its meaning.

Bits per Second (bps). Bits transmitted or received.

Bit. Binary digit. One bit is the basic unit of binary information. Generally, eight consecutive bits compose one byte of data. The pattern of 0 and 1 values within the byte determines its meaning.

bps. See **Bits Per Second**.

Byte. On an addressable boundary, eight adjacent binary digits (0 and 1) combined in a pattern to represent a specific character or numeric value. Bits are numbered from the right, 0 through 7, with bit 0 the low-order bit. One byte in memory is used to store one ASCII character.

boot or boot-up. The process a computer goes through when it starts. During boot-up, the computer can run self-diagnostic tests and configure hardware and software.

C

CDRH. Center for Devices and Radiological Health. A federal agency responsible for regulating laser product safety. This agency specifies various laser operation classes based on power output during operation.

CDRH Class 1. This is the lowest power CDRH laser classification. This class is considered intrinsically safe, even if all laser output were directed into the eye's pupil. There are no special operating procedures for this class.

CDRH Class 2. No additional software mechanisms are needed to conform to this limit. Laser operation in this class poses no danger for unintentional direct human exposure.

Character. A pattern of bars and spaces which either directly represents data or indicates a control function, such as a number, letter, punctuation mark, or communications control contained in a message.

Character Set. Those characters available for encoding in a particular bar code symbology.

Check Digit. A digit used to verify a correct symbol decode. The scanner inserts the decoded data into an arithmetic formula and checks that the resulting number matches the encoded check digit. Check digits are required for UPC but are optional for other symbologies. Using check digits decreases the chance of substitution errors when a symbol is decoded.

Codabar. A discrete self-checking code with a character set consisting of digits 0 to 9 and six additional characters: (“-”, “\$”, “:”, “/”, “,”, and “+”).

Code 128. A high density symbology which allows the controller to encode all 128 ASCII characters without adding extra symbol elements.

Code 3 of 9 (Code 39). A versatile and widely used alphanumeric bar code symbology with a set of 43 character types, including all uppercase letters, numerals from 0 to 9 and 7 special characters (“-”, “:”, “/”, “+”, “%”, “\$” and space). The code name is derived from the fact that 3 of 9 elements representing a character are wide, while the remaining 6 are narrow.

Code 93. An industrial symbology compatible with Code 39 but offering a full character ASCII set and a higher coding density than Code 39.

Code Length. Number of data characters in a bar code between the start and stop characters, not including those characters.

Cold Boot. A cold boot restarts the mobile computer and erases all user stored records and entries.

COM port. Communication port; ports are identified by number, e.g., COM1, COM2.

Continuous Code. A bar code or symbol in which all spaces within the symbol are parts of characters. There are no intercharacter gaps in a continuous code. The absence of gaps allows for greater information density.

Cradle. A cradle is used for charging the terminal battery and for communicating with a host computer, and provides a storage place for the terminal when not in use.

D

Dead Zone. An area within a scanner's field of view, in which specular reflection may prevent a successful decode.

Decode. To recognize a bar code symbology (e.g., UPC/EAN) and then analyze the content of the specific bar code scanned.

Decode Algorithm. A decoding scheme that converts pulse widths into data representation of the letters or numbers encoded within a bar code symbol.

Decryption. Decryption is the decoding and unscrambling of received encrypted data. Also see, **Encryption** and **Key**.

Depth of Field. The range between minimum and maximum distances at which a scanner can read a symbol with a certain minimum element width.

Discrete Code. A bar code or symbol in which the spaces between characters (intercharacter gaps) are not part of the code.

Discrete 2 of 5. A binary bar code symbology representing each character by a group of five bars, two of which are wide. The location of wide bars in the group determines which character is encoded; spaces are insignificant. Only numeric characters (0 to 9) and START/STOP characters may be encoded.

E

EAN. European Article Number. This European/International version of the UPC provides its own coding format and symbology standards. Element dimensions are specified metrically. EAN is used primarily in retail.

Element. Generic term for a bar or space.

EMDK. Enterprise Mobility Developer's Kit.

Encoded Area. Total linear dimension occupied by all characters of a code pattern, including start/stop characters and data.

ESD. Electro-Static Discharge

ESN. Electronic Serial Number. The unique hardware number associated with a cellular device, which is transmitted to the system when the device communicates with the cellular system.

Ethernet. Ethernet communication port. Allows a wired interface to a radio network.

F

Flash Memory. Flash memory is nonvolatile, semi-permanent storage that can be electronically erased in the circuit and reprogrammed. Mobile computers may use Flash memory to store the operating system (ROM-DOS), the terminal emulators, and the Citrix ICA Client for DOS.

FTP. See **File Transfer Protocol**.

Flash Memory. Flash memory is responsible for storing the system firmware and is non-volatile. If the system power is interrupted the data is not be lost.

G

Gateway Address. An IP address for a network gateway or router. A mobile computer may be part of a subnet as specified by its IP address and Netmask. It can send packets directly to any node on the same subnet. If the destination node is on a different subnet, then the terminal sends the packet to the gateway first. The gateway determines how to route the packet to the destination subnet. This field is an option used by networks that require gateways.

H

Hard Reset. See **Cold Boot**.

Hz. Hertz; A unit of frequency equal to one cycle per second.

Host Computer. A computer that serves other terminals in a network, providing such services as computation, database access, supervisory programs and network control.

I

IEC. International Electrotechnical Commission. This international agency regulates laser safety by specifying various laser operation classes based on power output during operation.

IEC (825) Class 1. This is the lowest power IEC laser classification. Conformity is ensured through a software restriction of 120 seconds of laser operation within any 1000 second window and an automatic laser shutdown if the scanner's oscillating mirror fails.

Interleaved 2 of 5. A binary bar code symbology representing character pairs in groups of five bars and five interleaved spaces. Interleaving provides for greater information density. The location of wide elements (bar/spaces) within each group determines which characters are encoded. This continuous code type uses no intercharacter spaces. Only numeric (0 to 9) and START/STOP characters may be encoded.

imaging scanning . Mobile computers with an integrated imager use digital camera technology to take a digital picture of a bar code, store the resulting image in memory and execute state-of-the-art software decoding algorithms to extract the data from the image.

Intercharacter Gap. The space between two adjacent bar code characters in a discrete code.

Interleaved Bar Code. A bar code in which characters are paired together, using bars to represent the first character and the intervening spaces to represent the second.

Interleaved 2 of 5. A binary bar code symbology representing character pairs in groups of five bars and five interleaved spaces. Interleaving provides for greater information density. The location of wide elements (bar/spaces) within each group determines which characters are encoded. This continuous code type uses no intercharacter spaces. Only numeric (0 to 9) and START/STOP characters may be encoded.

IP. Internet Protocol. The IP part of the TCP/IP communications protocol. IP implements the network layer (layer 3) of the protocol, which contains a network address and is used to route a message to a different network or subnetwork. IP accepts "packets" from the layer 4 transport protocol (TCP or UDP), adds its own header to it and delivers a "datagram" to the layer 2 data link protocol. It may also break the packet into fragments to support the maximum transmission unit (MTU) of the network.

IP Address. (Internet Protocol address) The address of a computer attached to an IP network. Every client and server station must have a unique IP address. A 32-bit address used by a computer on a IP network. Client workstations have either a permanent address or one that is dynamically assigned to them each session. IP addresses are written as four sets of numbers separated by periods; for example, 204.171.64.2.

L

LAN. Local area network. A radio network that supports data communication within a local area, such as within a warehouse of building.

laser scanner. A type of bar code reader that uses a beam of laser light.

LASER. Light Amplification by Stimulated Emission of Radiation. The laser is an intense light source. Light from a laser is all the same frequency, unlike the output of an incandescent bulb. Laser light is typically coherent and has a high energy density.

Laser Diode. A gallium-arsenide semiconductor type of laser connected to a power source to generate a laser beam. This laser type is a compact source of coherent light.

LED Indicator. A semiconductor diode (LED - Light Emitting Diode) used as an indicator, often in digital displays. The semiconductor uses applied voltage to produce light of a certain frequency determined by the semiconductor's particular chemical composition.

Light Emitting Diode. See **LED**.

M

MC. Mobile Computer.

MIL. 1 mil = 1 thousandth of an inch.

MIN. Mobile Identification Number. The unique account number associated with a cellular device. It is broadcast by the cellular device when accessing the cellular system.

Misread (Misdecode). A condition which occurs when the data output of a reader or interface controller does not agree with the data encoded within a bar code symbol.

Mobile Computer. In this text, *mobile computer* refers to the Symbol portable computer. It can be set up to run as a stand-alone device, or it can be set up to communicate with a network, using wireless radio technology.

N

Nominal. The exact (or ideal) intended value for a specified parameter. Tolerances are specified as positive and negative deviations from this value.

Nominal Size. Standard size for a bar code symbol. Most UPC/EAN codes are used over a range of magnifications (e.g., from 0.80 to 2.00 of nominal).

NVM. Non-Volatile Memory.

P

Parameter. A variable that can have different values assigned to it.

PDT. Portable Data Terminal.

Percent Decode. The average probability that a single scan of a bar code would result in a successful decode. In a well-designed bar code scanning system, that probability should approach near 100%.

Q

Quiet Zone. A clear space, containing no dark marks, which precedes the start character of a bar code symbol and follows the stop character.

R

RAM. Random Access Memory. Data in RAM can be accessed in random order, and quickly written and read.

Reflectance. Amount of light returned from an illuminated surface.

Resolution. The narrowest element dimension which is distinguished by a particular reading device or printed with a particular device or method.

RF. Radio Frequency.

ROM. Read-Only Memory. Data stored in ROM cannot be changed or removed.

Router. A device that connects networks and supports the required protocols for packet filtering. Routers are typically used to extend the range of cabling and to organize the topology of a network into subnets. See **Subnet**.

RS232. An Electronic Industries Association (EIA) standard that defines the connector, connector pins, and signals used to transfer data serially from one device to another.

S

Scan Area. Area intended to contain a symbol.

Scanner. An electronic device used to scan bar code symbols and produce a digitized pattern that corresponds to the bars and spaces of the symbol. Its three main components are:

1. Light source (laser or photoelectric cell) - illuminates a bar code.
2. Photodetector - registers the difference in reflected light (more light reflected from spaces).
3. Signal conditioning circuit - transforms optical detector output into a digitized bar pattern.

Scanning Mode. The scanner is energized, programmed and ready to read a bar code.

Scanning Sequence. A method of programming or configuring parameters for a bar code reading system by scanning bar code menus.

SDK. Software Development Kit

Self-Checking Code. A symbology that uses a checking algorithm to detect encoding errors within the characters of a bar code symbol.

Shared Key. Shared Key authentication is an algorithm where both the AP and the MU share an authentication key.

SID. System Identification code. An identifier issued by the FCC for each market. It is also broadcast by the cellular carriers to allow cellular devices to distinguish between the home and roaming service.

Soft Reset. See **Warm Boot**.

Space. The lighter element of a bar code formed by the background between bars.

Specular Reflection. The mirror-like direct reflection of light from a surface, which can cause difficulty decoding a bar code.

Spring Radio Protocol. A radio protocol that may be used by the Symbol radio card. Symbol Radio cards that use the Spring protocol also have an Net ID.

Start/Stop Character. A pattern of bars and spaces that provides the scanner with start and stop reading instructions and scanning direction. The start and stop characters are normally to the left and right margins of a horizontal code.

Subnet. A subset of nodes on a network that are serviced by the same router. See **Router**.

Subnet Mask. A 32-bit number used to separate the network and host sections of an IP address. A custom subnet mask subdivides an IP network into smaller subsections. The mask is a binary pattern that is matched up with the IP address to turn part of the host ID address field into a field for subnets. Default is often 255.255.255.0.

Substrate. A foundation material on which a substance or image is placed.

SVTP. Symbol Virtual Terminal Program.

Symbol. A scannable unit that encodes data within the conventions of a certain symbology, usually including start/stop characters, quiet zones, data characters and check characters.

Symbol Aspect Ratio. The ratio of symbol height to symbol width.

Symbol Height. The distance between the outside edges of the quiet zones of the first row and the last row.

Symbol Length. Length of symbol measured from the beginning of the quiet zone (margin) adjacent to the start character to the end of the quiet zone (margin) adjacent to a stop character.

Symbology. The structural rules and conventions for representing data within a particular bar code type (e.g. UPC/EAN, Code 39, PDF417, etc.).

T

Tolerance. Allowable deviation from the nominal bar or space width.

U

UPC. Universal Product Code. A relatively complex numeric symbology. Each character consists of two bars and two spaces, each of which is any of four widths. The standard symbology for retail food packages in the United States.

V

Visible Laser Diode (VLD). A solid state device which produces visible laser light.

W

WAN. Wide-Area Network. A radio network that supports data communication beyond a local area. That is, information can be sent across a city, state, or even nationwide.

Warm Boot. A warm boot restarts the mobile computer by closing all running programs. All data that is not saved to flash memory is lost.

Wireless Local Area Network (WLAN). See LAN.

Wireless Wide Area Network (WWAN). See WAN.

WNMP. (Wireless Network Management Protocol) This is Symbol's proprietary MAC layer protocol used for inter access point communication and other MAC layer communication.

Preliminary

Index

Numerics

28-key keypad	B-2, B-13
2-D bar codes	2-22
38-key keypad	B-6, B-13
48-key keypad	B-9, B-13

A

accessories	1-1
cables	4-9
four slot charge only cradle	4-6
LED indicators	4-6
four slot cradles	
battery charging	4-6
four slot spare battery charger	
battery charging	4-8
LED indicators	4-8
MC3000 communication/charge cables	
battery charging	4-10
LED indicators	4-10
plastic holster	4-13, 4-15
SD card	1-5
single slot serial/USB cradle	4-3
battery charging	4-3
LED indicators	4-4
stylus	4-2
UBC adapter	
battery charging	4-11
LED indicators	4-11
active and indicate programs	2-2
active tasks	2-5
ActiveSync	xvi
icon	2-9
adaptive frequency hopping	3-1
AFH	3-1
attaching strap/door assembly	1-13

B

bar codes	
two dimensional	2-22
battery	
charging	1-8
temperature range	A-5
install	1-6
status	2-2
battery charge status	2-2
battery chargers	
four slot spare battery charger	
battery charging	4-8
LED indicators	4-8
MC3000 communication/charge cables	
battery charging	4-10
LED indicators	4-10
UBC adapter	
battery charging	4-11
LED indicators	4-11
battery charging	1-8
backup battery	1-8
four slot cradles	4-6
four slot spare battery charger	4-8
main battery	1-8
MC3000 communication/charge cables	4-10
battery charging	4-10
temperature range	1-8
UBC adapter	4-11
battery status	2-2, 2-3
beeper	1-2
beeper volume	B-13
Bluetooth	3-1
adaptive frequency hopping	3-1
bonding	3-38
deleting bonded device	3-39
security	3-2

- turning off 3-5, 3-14, 3-21
- turning on 3-5, 3-14, 3-21
- bluetooth
 - communicating icon 2-9
 - disabled icon 2-8
 - discovering devices 3-6, 3-15, 3-22
 - enabled icon 2-8
 - icon 2-3
 - turning on and off 3-5, 3-14, 3-21
- bonding
 - Bluetooth 3-38
- boot
 - cold 2-27, 3-4
 - warm 2-27, 3-4
- bullets xv

C

- calibration screen 1-10
- characters, special B-14
- charge battery 1-8
- charge LED indicator 1-2, 1-4
- charging
 - spare batteries 1-9
 - temperature range A-5
- charging battery 1-8
- charging, temperature range 1-8
- cleaning 5-1
- clock, display 2-6
- cold boot 2-27, 3-4
- command bar 2-8
 - icons 2-7, 2-8
- command bar icons 2-8
- communication status 2-2
- configuration xii
- contrast settings B-13
- conventions
 - notational xv
- cradles
 - four slot charge only cradle 4-6
 - LED indicators 4-6
 - four slot cradles
 - battery charging 4-6
 - single slot serial/USB cradle
 - battery charging 4-3
 - LED indicators 4-4
 - troubleshooting 5-9

D

- data capture xii
 - imager operational modes
 - decode mode 2-23
 - image capture mode 2-23

- pick list mode 2-23
- imaging 2-22
- scanning 2-23
- two dimensional bar codes 2-22
- DCP xvi, 4-2
- decode distances
 - imager 2-26
 - laser scanner 2-22
- decode ranges 2-25
- decode zone
 - laser scanner 35° 2-20
 - laser scanner 47° 2-21
- deleting Bluetooth bond 3-39
- demo window 1-11, 2-1, 2-2
- desktop window 2-2
- device configuration package 4-2
- Device Configuration Package, see DCP
- display xii
- display clock 2-6
- display contrast B-13
- documentation updates xvi
- documents 2-4

E

- electro-static discharge
- email notification icon 2-8
- end task 2-5
- entering data with scanner 2-15
- entering information 2-15
 - scanning 2-15
- Enterprise Mobility Developer Kit 4-2
- Enterprise Mobility Developer Kit for .NET, see EMDK
- ESD 1-5

F

- fabric holster 4-2, 4-15
- favorites 2-4
- four slot charge only cradle 4-1, 4-6
 - LED indicators 4-6
- four slot cradles 1-8
 - battery charging 4-6
- four slot Ethernet cradle 4-1
- four slot spare battery charger 1-8, 1-9, 4-1
 - battery charging 4-8
 - LED indicators 4-8
 - troubleshooting 5-9
- function status 2-2

H

- hard reset 2-26, 2-27, 3-4
- headset 2-18

headset jack 1-3
 help 2-4
 holster, fabric 4-2, 4-15

I

icons
 ActiveSync 2-9
 battery 2-8
 bluetooth 2-3
 bluetooth communicating 2-9
 bluetooth disabled 2-8
 bluetooth enabled 2-8
 connectivity 2-8
 e-mail 2-8
 instant message 2-8
 speaker 2-7
 status 2-7, 2-8
 wireless applications 2-8

imager decode distances 2-26

imager. See data capture, imaging

imaging 2-23

indicator LED bar 1-2, 1-4, 4-4

information, service xii

K

keypad
 28-key B-1, B-2, B-13
 38-key B-1, B-6, B-13
 48-key B-1, B-6, B-13
 keypad configurations B-1
 keypad special functions B-13
 keypads xii
 input modes B-4, B-8, B-11
 types B-11

L

laser scanning 2-18

LEDs

scan and decode 2-23

locking the mobile computer 2-12

M

main battery 1-8
 charging 1-5
 temperature range A-5
 inserting 1-5
 maintenance 5-1
 MC3000 communication/charge cables 4-9
 battery charging 4-10

LED indicators 4-10

MC3000R parts 1-3

MC3000S parts 1-3

memory xii

microphone 1-2

mobile computer

cold boot 2-27

hard reset 2-26, 2-27

power on 2-1

reset 2-26

scanning 2-18

soft reset 2-26

warm boot 2-26, 2-27

Monarch printer cable 4-1, 4-9

N

navigating software 2-1

numeric keypad

input modes B-4, B-8

O

OmniNeer printer cable 4-1, 4-9

operating

environment A-1

operating system xii

P

parts 1-2, 1-3, 1-4, 1-5

passwords 2-13

hint 2-13

plastic holster 4-2, 4-13

platform SDK xvi

power button 2-1

power supply 4-1

program menu 2-4

properties 2-5

Q

QWERTY keypad

input modes B-11

R

radios xii

receiver 1-2

receiver volume B-13

remove battery 1-11, 1-12

remove the Strap/Door Assembly 1-13, 1-14

replace the strap/door assembly 1-14

reset

- hard 2-27, 3-4
- soft 2-27, 3-4
- resetting 2-26
- resume 3-4
- rotating scan head 1-2
- rotating scan turret 1-3
- RS232 charge cable 1-8, 4-1, 4-9
- run 2-4

S

- scan 2-15
- scan buttons 1-2, 1-4
- scan LED indicators 1-2, 1-4, 2-19
- scan status 2-19
- scan window 1-3
- scanning 2-15, 2-18
 - adjusting the distance 2-18
 - angle 2-19
 - imaging 2-22
 - indicator 2-19
 - LED indicators 2-19
 - range 2-19
- scanning considerations 2-19
- screen
 - calibration 1-10
 - contrast B-13
- SD card 1-5
 - installation 1-6
- secure device card 1-5
- security
 - Bluetooth 3-2
- serial charge cable 1-8, 4-9
- series 3000 demo window 2-1
- service 5-1
- settings 2-4
- shoulder strap 4-15, 4-16
- show clock 2-6
- single slot cradle RS232 cable 4-1
- single slot cradle USB cable 4-1
- single slot serial/USB cradle 1-8, 1-9, 4-1, 4-3
 - battery charging 4-3
 - LED indicators 4-4
- soft reset 2-26, 2-27, 3-4
- spare battery
 - charging 1-9
- special characters B-14
- special functions, keypad B-13
- start menu 2-4
- starting the mobile computer 1-5, 1-10
- startup 1-5
- status 2-7
- status icon 2-2, 2-3, 2-7
- status icons 2-7, 2-8

- storing 5-1
- strap/door assembly 1-3
 - attaching 1-13
- strap/door assembly removal 1-14
- stylus 1-3, 1-9, 4-2
- stylus holder 1-3
- suspend 2-4, 3-4
- synchronize with PC
 - using Bluetooth 3-11, 3-19

T

- task manager 2-5
- taskbar 2-2
- technical specifications A-1
- temperature A-2
 - battery charging A-5
- Today screen 2-7
- troubleshooting 5-5
 - cables 5-10
 - four slot charge only cradle 5-8
 - four slot spare battery charger 5-9
 - mobile computer 5-5
 - single slot serial/USB cradle 5-7
 - UBC adapter 5-10
- turning the radios off
 - WLAN 1-16

U

- UBC adapter 1-8, 1-9, 4-1
 - battery charging 4-11
 - LED indicators 4-11
- UBC adapter
 - LED indicators 4-11
- UBC adapter LED charge indications 4-11
- universal battery charger adapter 1-8, 4-1
- unpacking 1-1
- updates, documentation xvi
- USB client charge cable 1-8, 4-1, 4-9
- using headset 2-18
- using stylus 1-9

V

- volume B-13

W

- wakeup condition settings 1-11
- wakeup conditions 2-28
- warm boot 2-26, 2-27, 3-4
- Windows CE .NET 5.0 Professional 2-2, 2-4
- Windows Mobile 6.1 2-7

Wireless	1-16
Wireless Manager	1-16
wireless status	2-8
WLAN 802.11a/b/g	xii
WPAN Bluetooth	xii

Z

Zebra printer cable	4-1, 4-9
---------------------------	----------

Preliminary

Preliminary

Preliminary

Preliminary



MOTOROLA

Motorola, Inc.
One Motorola Plaza
Holtsville, New York 11742, USA
1-800-927-9626
<http://www.motorola.com/enterprisemobility>

MOTOROLA and the Stylized M Logo and Symbol and the Symbol logo are registered in the U.S. Patent and Trademark Office.
All other product or service names are the property of their registered owners.
© Motorola, Inc. 2009