



Cleaning

Cleaning System



Caution • PROTECT YOUR FACTORY WARRANTY!

The recommended maintenance procedures must be performed to maintain your factory warranty. Other than the recommended cleaning procedures described in this manual, allow only Zebra authorized technicians to service the P100i Printer.

NEVER loosen, tighten, adjust, or bend, etc., a part or cable inside the printer.

NEVER use a high-pressure air compressor to remove particles in the printer.

Your P100i Printer includes a simple cleaning system using Pre-Saturated Cleaning Cards provided. The regular use of these cards will clean and maintain important parts of your printer that cannot be reached: including Print Head, the Transport Rollers, and the Magnetic Encoder Station (optional feature).

When to Clean

After approximately 1000 color cards have been printed, the printer LCD will prompt CLEAN PRINTER, or when print quality has been degraded.

How to Clean

1. Leave power on.
2. Press and hold the Multi-Function Control Button for 5 seconds.
3. When the cleaning cycle is initiated, the LCD message **REMOVE RIBBON THEN CLOSE LID** will display.

Cleaning Cleaning System

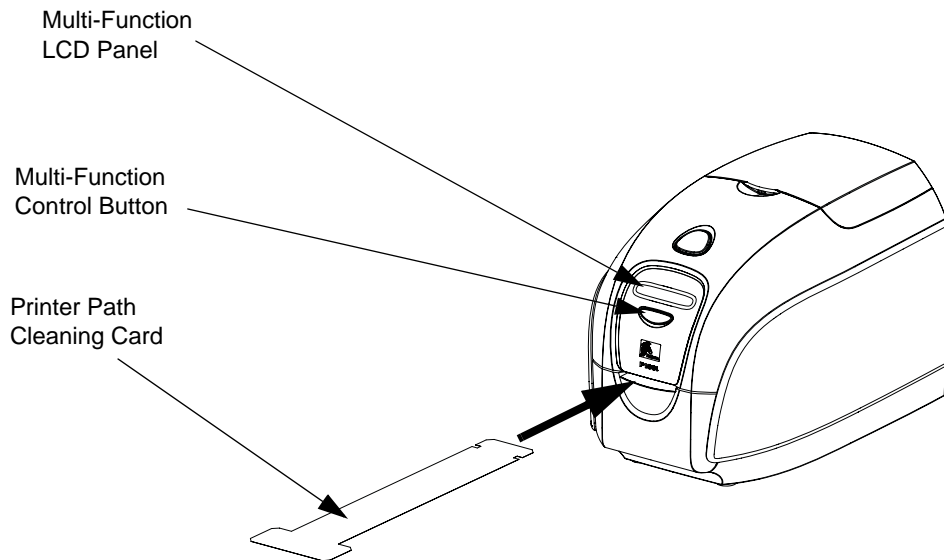

4. After the ribbon is removed and the lid is closed, the message **EMPTY FEEDER THEN CLOSE COVER** will display.
5. If the lid is opened and closed without removing the ribbon, the **REMOVE RIBBON THEN CLOSE LID** message will remain.
6. Once the cover is closed, the firmware will eject any card inside the printer. The message **EJECTING CARD** will display.
7. The LCD will then display **FEED LONG CLEANING CARD IN EXIT**. When the card sensor registers the presence of the cleaning card, the rollers should take the card into the printer.
8. When the cleaning process is done, the printer will eject the cleaning card. If the card sensor still senses the cleaning card, the message **REMOVE LONG CLEANING CARD** will display.
9. After the card is removed, the LCD will display **READY**. You may now reload the ribbon and continue printing.

Cleaning the Print Head

Use of the cleaning cards will normally do an adequate job of cleaning the printer. However, a separate Print head cleaning, using swabs, can remove more stubborn deposits when print anomalies persist. To avoid deposits, only use foam-tipped swabs.



Caution • Never use a sharp object to scrape deposits from the print head. Permanent damage to the print head will result

1. Place the printer power switch in the OFF (0) position.
2. Open printer lid by pressing cover release button and open cover fully to reveal the print head mounted to inside of the cover.

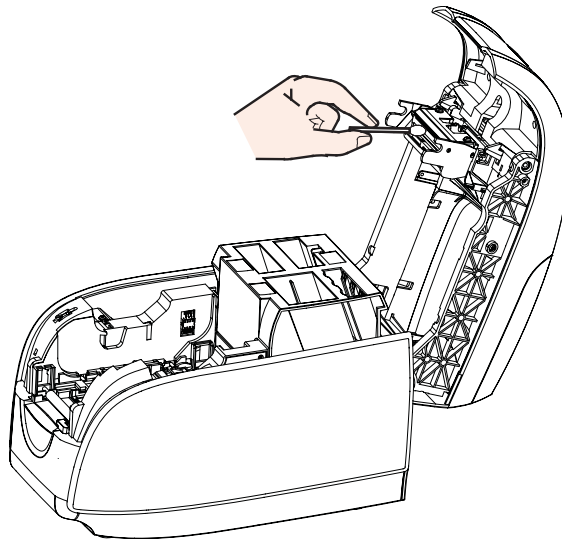

3. Clean Print Head by moving alcohol-moistened swab tip side-to-side across Print Head elements. Only use moderate force.
4. Allow two to three minutes for the printhead to dry before placing the printer power switch in the ON (|) position.
5. To reorder swabs, reference the P110i Printer Media List.

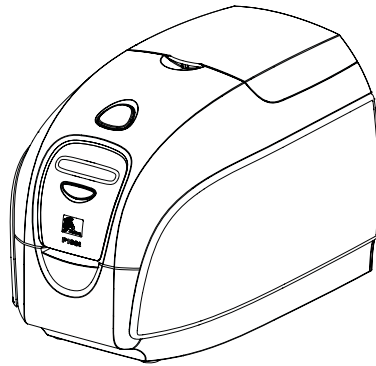



Troubleshooting

Troubleshooting Procedures

The table below offers causes and solutions to symptoms related to improper operation. Check the table when experiencing any loss of operation or print quality.

Problem / Description	Cause / Solution
The LCD Panel displays OUT OF RIBBON message.	1. Check ribbon. Replace if defective or entirely used. Ribbon will automatically synchronize and printing will restart with a new card.
The LCD Panel displays PRINT HEAD OPEN message.	1. Check that Print Head Carriage is closed and latched. If not, close and latch it.

The LCD Panel displays MECHANICAL ERROR message.	<ol style="list-style-type: none">1. Check that you are using the correct card type (see Technical Specifications).2. Check that ribbon is loaded correctly.
The LCD Panel displays ENCODING ERROR message.	<ol style="list-style-type: none">1. Check that you are using the correct magnetic card type (for low or high coercivity encoding).2. Verify command syntax.3. Contact Zebra technical support.
The LCD Panel displays CLEAN PRINTER message.	<ol style="list-style-type: none">1. Printer cleaning required (see Chapter 4).

Print Quality Issues

This section will help you resolve print quality problems. The print quality is dependent on several factors. The two most important factors that will increase your print quality are cleanliness and card stock. To diagnose and fix print quality problems, follow the troubleshooting procedures below:

Example • Small spots appear on the printed card with a non-printed area or a different color.

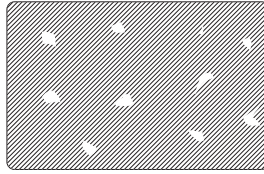

Possible Cause:

- Contamination on the card surface

Solutions:

- Check that cards are stored in a dust free environment
- Use a different supply of cards

Possible Cause:

- Cleaning roller not installed
- Dust inside the printer and/or dirty Cleaning Roller

Solutions:

- Perform a Cleaning of the printer (reference Chapter 5)
- Check that the protective cover was removed from the ribbon cartridge cleaning roller (reference Chapter 3).
- Replace the cleaning roller located at the front of the printer (reference Appendix B).

Example • There are non-printing horizontal lines (white) on the card surfaces.

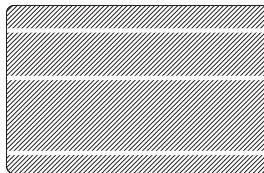

Possible Cause:

- Ribbon cartridge is not correctly positioned.

Solutions:

- Ensure that the ribbon is properly rolled onto the ribbon cores of the cartridge and that there are no wrinkles in the ribbon.
- Replace ribbon cassette.

Possible Cause:

- Print Head is dirty.

Solutions:

- Clean the Print Head

Possible Cause:

- Print Head elements are damaged (e.g., scratched or burnt).

Solutions:

- Call Zebra Customer Service for Print Head replacement information.

Example • Printing shows very pale or inconsistent results.

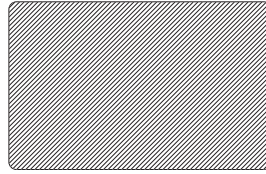

Possible Cause:

- Ribbon cartridge have been stored improperly or is damaged.

Solution:

- Change ribbon cartridge and print again.

Possible Cause:

- Cards may not meet specifications

Solution:

- Use a different supply of cards.

Possible Cause:

- Contrast and/or Intensity may be set to values which are too high.

Solution:

- Adjust Contrast and/or Intensity values in software.

Possible Cause:

- Dust or embedded contamination on elements of the Print Head.

Solution:

- Perform a Cleaning of the Print Head (Reference Chapter 4, Cleaning the Print Head)

Example • Printing shows blurry printed image.

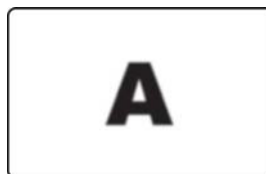

Possible Cause:

- Ribbon cartridge may not be correctly positioned.

Solution:

- Check that the ribbon is properly rolled onto the ribbon cores of the cartridge, with no wrinkles.
- Replace ribbon cartridge, making sure it locks in place, and print again.

Possible Cause:

- Ribbon may not be synchronized on the correct color panel position.

Solution:

- Open lid, then close lid to synchronize ribbon.

Possible Cause:

- Cards may not meet specifications.

Solution:

- Use a different supply of cards.

Possible Cause:

- Dust or embedded contamination inside the printer and/or dirty Cleaning Roller.

Solution:

- Clean the Print Head.
- Replace Cleaning Roller.

Example • No printing on the card.



Possible Cause:

- Ribbon cartridge may not be installed in the printer.

Solution:

- Check for ribbon cartridge in the printer.

Possible Cause:

- Cards may not meet specifications.

Solution:

- Use a different supply of cards.

Possible Cause:

- Cable on Print Head may be disconnected.
- Print Head elements may be scratched or burnt.

Solution:

- Call Service for Print Head repair or replacement information.

Troubleshooting the Ethernet Connection and Adapter

Resetting to Factory Defaults

To reset the Ethernet Adapter configuration parameters to the factory defaults, press the Ethernet Switch

and hold it in while turning the printer power on. Keep the Panel Button pressed until the Status Indicator light turns green, then release the Ethernet Switch. To print a configuration card, press and hold the Ethernet Switch until a card starts to print.

Ethernet Adapter Status Indicator

A bi-color Status Indicator displays the operational status of the Ethernet Adapter. The following conditions might occur:

1. During normal operation, the LED is solid **green** for more than 30 seconds. This indicates all the hardware is functioning properly and the Ethernet Adapter has detected the presence of the network. It does not mean the Ethernet Adapter has an IP address or is attached to a printer queue.
2. If the LED is rapidly flashing **green** (9 times/sec), the Ethernet Adapter has not detected the presence of a network cable. To solve the problem:
 - Verify that the network cable is appropriate for the network and has an RJ-45 connector.
 - Turn the printer power off (●). Remove the network cable from the Ethernet Adapter. Plug the network cable back in until you hear a positive click. Check the other end of the cable in the same manner. Turn the printer power on; if the Ethernet Adapter still does not detect a cable, continue.
 - Connect the Ethernet Adapter to a known good network connection. If the Ethernet Adapter is still unable to detect the network cable, contact Technical Support for assistance.



Important • Cables with a rating higher than CAT-6 have **not** been tested.

3. If the LED is slowly flashing green (1 time/sec), the Ethernet Adapter is trying to print a job. If the job does not print, check the following:
 - Verify that the printer has media and ribbon. If the printer is showing any errors, it is unlikely that the Ethernet Adapter can send data to the printer. The LED continues to blink until the printer malfunction is resolved or until the printer is turned off (●).
 - Flashing red indicates the Power On Self Test (POST) is in progress.
4. If the LED is solid **red** for more than 30 seconds, the Ethernet Adapter has failed the POST. A failed POST can be caused by any of the following:
 - The printer attached to the Ethernet Adapter device is malfunctioning. Turn the printer power off, wait 10 seconds, then turn the printer back on (|).
 - If the Ethernet Adapter still fails the POST, the Ethernet Adapter has a hardware problem that can be fixed only by replacing or returning the unit. Contact Technical Support for repair or replacement information.
5. If the LED is alternately flashing **red** and **green** for longer than 2 minutes, the Ethernet Adapter is in firmware-download mode. This means it is waiting for new firmware data to be sent before it continues normal functioning. Perform the following:
 - If the Ethernet Adapter was purposely put into firmware-download mode, finish the download with the proper update utility. Contact the Zebra web site at <http://www.zebra.com> to download this utility.
 - Contact Technical Support for help recovering this unit.

Network Status/Activity Indicator

A bi-color Status/Activity LED indicates network speed, established link, and network activity.

1. If the LED is off, no link was established.
2. If the LED is solid **green**, a 100Base link is established.
3. If the LED is flashing **green**, a 100Base link is established and network activity has been detected.
4. If the LED is solid **orange**, a 10Base link is established.
5. If the LED is flashing **orange**, a 10Base link was established and network activity has been detected.

Network activity detected by this LED does not mean the activity is data for the print server. The activity is all activity on the network seen on the Ethernet Adapter.

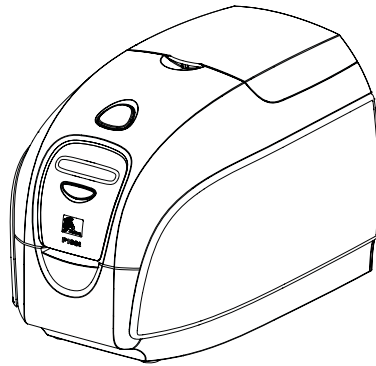



Technical Specifications

General

- Load-N-Go™ drop-in ribbon cartridge
- 16-digit LCD display
- Windows® drivers for 2000 and XP

Color Printing

- Color dye sublimation or monochrome thermal transfer printing
- 300 dpi (11.8 dots/mm) print resolution

Bar Code

- Code 39, Code 128 B & C with & without check digit
- 2 of 5 & 2 of 5 Interleaved
- UPC-A, EAN 8 & EAN 13
- PDF-417 2D bar code and other symbologies can be printed via Windows drivers

Cards

- Types: PVC, PVC Composite
- Card width/length: ISO CR-80-ISO 7810, 2.12" (54mm) x 3.38" (86mm)
- Magnetic Stripe-ISO 7811
- Smart Card-ISO 7816
- Card thickness: 30 mil (.76mm) (+/- 10%)

Ribbon Cartridges

- Load-N-Go™ ribbon cartridge with integrated card-cleaning roller
- *i* Series technology featuring contact-chip-based ribbon detection
- YMCKO: 200 cards/cartridge
- Monochrome: 1000 cards/cartridge in black or blue; 850 cards/cartridge white

Interfaces

- USB 1.1 (cable included)
- USB 1.1 and built-in Ethernet (optional)

Dimensions

- Width: 7.9 in (201mm)
- Depth: 12.9 in (328mm)
- Height: 8.5 in (216mm)
- Weight: 9.5 lbs (4.3kg)

Electrical

- 110 ~ 240 Volts AC, 50 ~ 60 Hz (auto switching)
- 8 MB image memory standard
- FCC Class A, CE, UL and CUL approved

Environmental

- Operating Temperature: 60°F to 86°F (15°C to 30°C)
- Operating Humidity: 20% to 65% non-condensing
- Storage Temperature: 23°F to 158°F (-5°C to 70°C)
- Storage Humidity: 20% to 70% non-condensing
- Ventilation: Free air

Options

- Magnetic encoder (30 mil cards only), 3 track HiCo/LoCo
- Ethernet (10/100 MBps); available at time of order only
- P100i Starter Kit (200 cards and 1 YMCKO ribbon)
- Cleaning Kit (1 cleaning card and 1 cleaning swab)

Card Dimensions

ISO standard dimensions for plain card

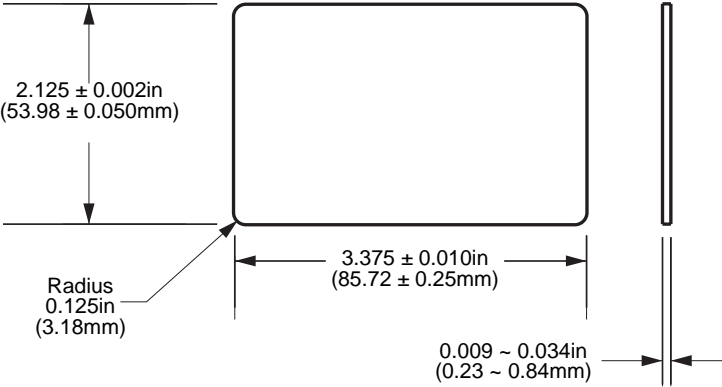

ISO standard dimensions for magnetic stripe card

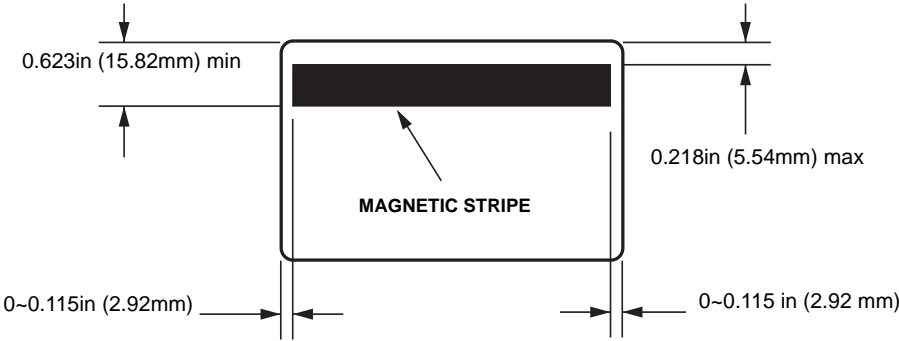

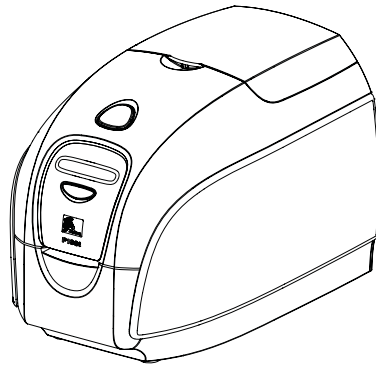

Appendix A

Magnetic Card Encoder



Magnetic Card Stripe Encoder

This section contains information on the additional operations of the P100i Printers with Magnetic Card Stripe Encoder.

Introduction

Operation and maintenance requirements for the P100i Printer with the optional magnetic card stripe encoder. The magnetic encoder can be set for either high or low coercivity.

Media Loading Orientation



Caution • ONLY USE cards that comply with ISO 7810 & 7811 standards for magnetic stripe cards. The magnetic stripe must be flush to the surface of the card to work properly. Never use cards which have taped-on magnetic stripes.

The magnetic encoder is a factory installed item with the read/write head positioned below or above the card path, available with HiCo or LoCo encoding.

When loading cards with magnetic stripes into the card feeder, please ensure that the magnetic stripe is toward the right side when facing the printer and down, as shown below.

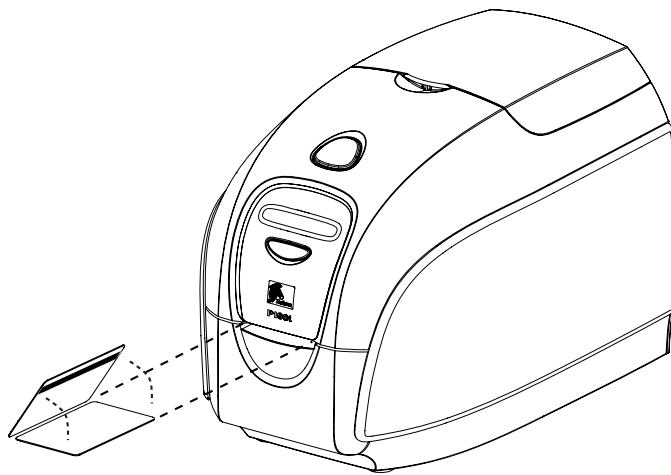

Note • Zebra approved HiCo & LoCo PVC cards are available. (Reference P100i printer Media List.)

Magnetic Encoder Cleaning

Use the standard cleaning card process as described in Chapter 4. This cleans the most important parts of the printer; including the Print Head, Transport Roller, and Magnetic Stripe Encoder.

ISO Standard Encoding

Track #	Field Separator	Track Density	Valid Characters	# of characters
1	^	210 BPI*	Alphanumeric (ASCII 20~95†)	79‡
2	=	75 BPI*	Numeric (ASCII 48~62)	40‡
3	=	210 BPI*	Numeric (ASCII 48~62)	107‡
<p>*Bits per inch †Except the “?” character ‡Including Start, Stop, and LRC characters. Also note that these 3 characters are automatically managed by the magnetic encoder according to the ISO Standard Norms.</p>				



Note • Refer to the Card Printer Programmer’s Manual for complete programming information.

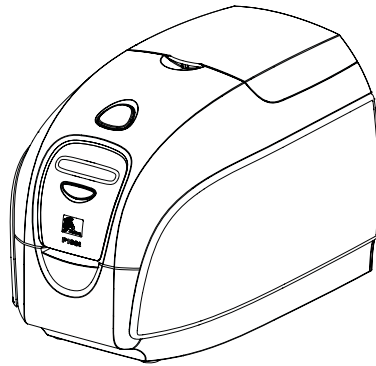

Appendix B

Connecting to a Network



Card printers can be connected to an Ethernet network in three ways.

Printer Sharing

In printer sharing, the printer is connected locally to the host computer and configured to be shared to other client computers. Client computers connect to the printer over the network through the host computer.

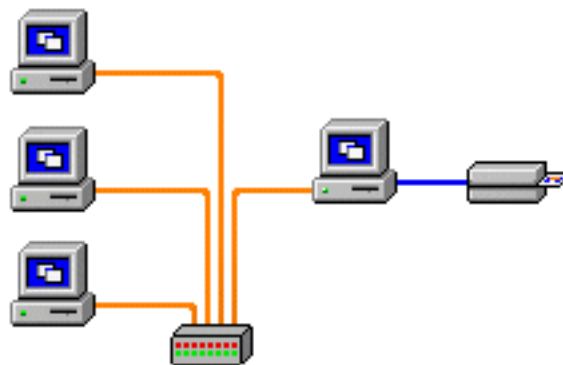

External Print Server

A stand alone device that acts as a server on the network specifically for receiving print jobs and passing them to the printer. Client computers connect to the print server over a network.

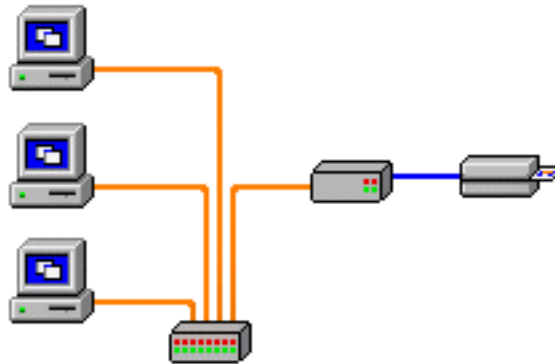

Internal Print Server

Similar to an external print server, except the print server is integrated into the printer. This removes the need for a separate power supply and separate device drivers. This is the simplest way to network a printer.

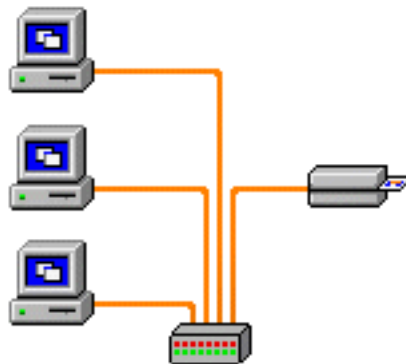

Appendix C

Smart Card Contact Station



This section contains information on the additional operations of a P100i Printer equipped with the optional Smart Card Contact Station.

Introduction

Smart Cards can have a built-in microcomputer and/or memory to store fingerprints, voice recognition patterns, medical records, and other such data. The printer may be equipped with an optional contact station for programming Smart Cards (ISO 7816). This printer model responds to commands that position the card at the contact station, where the printer connects to the contacts on the Smart Card. All other printer operations remain the same as the standard models.

Media Loading Orientation

Orient the cards with the gold-plated Smart Card contacts at the top surface of the card and nearer the card entry slot.

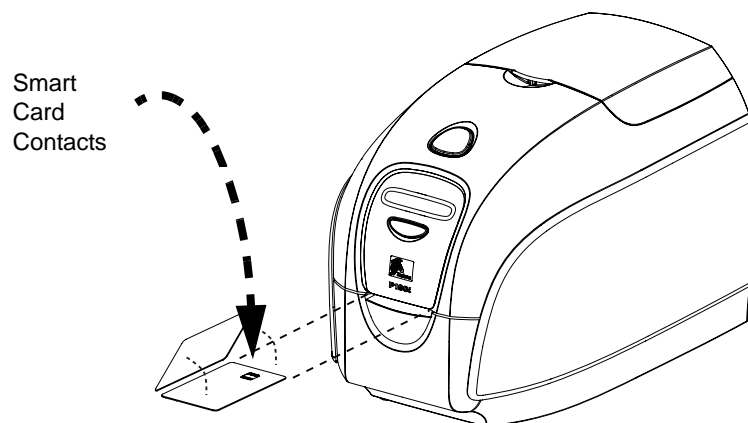

Smart Card Contact Station
Media Loading Orientation

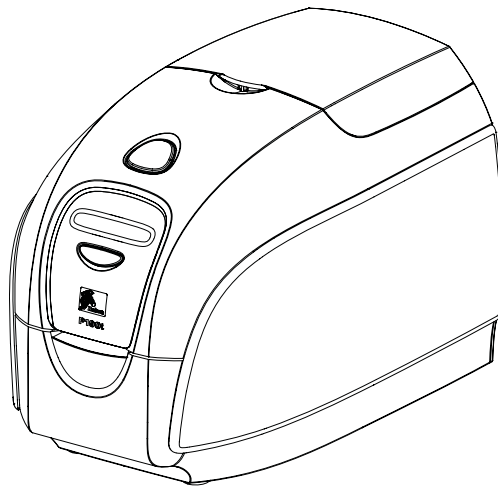

Appendix D

Worldwide Sales & Support



Sales and Support Locations

North America:

Zebra Technologies Card Printer Solutions
1001 Flynn Road
Camarillo, CA 93012-8706 USA
Phone: + 1 (805) 579 1800
Fax: + 1 (805) 579 1808
Toll free in US: (800) 452-4056
e-mail: cards@zebra.com

Europe, Middle East, and Africa:

Zebra Technologies Card Printer Solutions
The Valley Centre, Gordon Road
High Wycombe
Buckinghamshire HP13 6EQ
United Kingdom
Phone: + 44 (0) 870 241 1527
Fax: + 44 (0) 870 241 0765
e-mail: eurosales@zebra.com

Asia Pacific:

Zebra Technologies Card Printer Solutions
120 Robinson Road
#06-01 Parakou Building
Singapore 068913
Phone: + 65 6858 0722
Fax: + 65 6885 0836
e-mail: asiasales@zebra.com

Latin America:

Zebra Technologies Card Printer Solutions
9800 NW 41st Street, Suite 220
Doral, FL 33178 USA
Phone: + 1 (305) 558 3100
Fax: + 1 (305) 558-8485
e-mail: latinsales@zebra.com

Website

www.zebracard.com