

- b. Locate the Print Head protection pad and the Card Cleaning Cartridge location tape (see below).

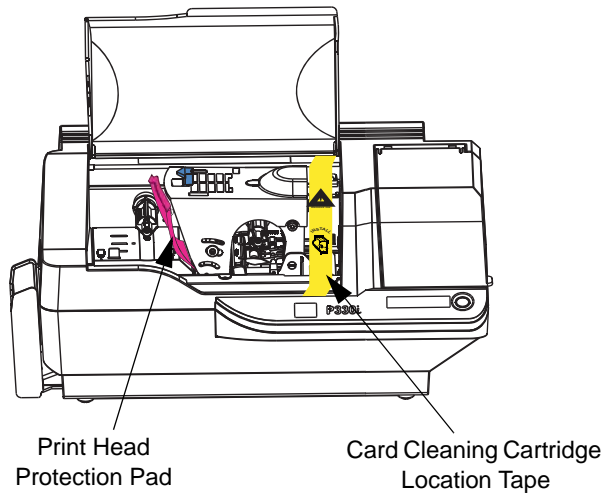

- c. Release the Print Head Carriage by pushing the Print Head Carriage Latch to the left, and raise the Print Head Carriage. It will remain open at about a 45° angle.

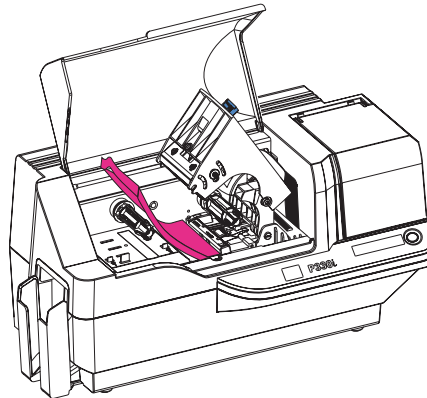
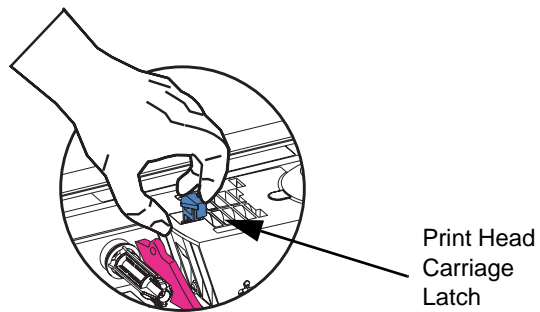

Installation and Setup

Installing the Print Driver Software and Setting Driver Options

- d. Remove the print head protection pad. Keep the pad, as well as the other packing material and the shipping carton, in case the printer is shipped or moved. If the original material is lost, a replacement Shipping Kit can be ordered from Zebra; please refer to the Media List on the Windows Drivers and User Documentation CD supplied with this printer.

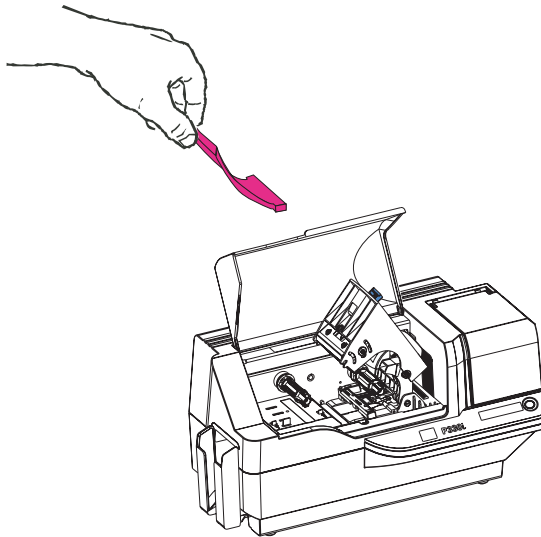

Installing the Print Driver Software and Setting Driver Options

Printing with the P330i Printer requires the Windows Printer Driver and your card design/issuing software or printer command level programming through the printer interface.

The P330i Card Printer can be used with any Windows 2000 or Windows XP computer, using the drivers provided on CD with the printer.

This section contains information on the printing of a sample card in color (using the 5-panel color ribbon YMCKO and the Windows Printer Driver).



Note • If updating the printer driver from a previous version, before installing the updated printer driver version, always delete the existing version from your computer.

Installing the P330i Print Driver

To install the P330i Printer Driver automatically on all Operating Systems, use the Zebra Install Wizard.



Note • Ensure that you have administrative privileges to perform this installation, or contact your IT department.

The Install Wizard will walk you through the appropriate installation steps. The Wizard will:

- Automatically launch when the driver CD is inserted.

- From the main menu of your documentation CD, select your desired language and then select “DRIVERS” from the subsequent menu. The Install Wizard will walk you through the appropriate steps.
- Delete previous versions of the driver and clean up any necessary Registry entries. You must select “Remove” from the install options to remove any previous driver versions.

Loading a Ribbon

i Series Printers require the use of *i* Series ribbons for full color printing. The Resin Thermal Transfer and Dye Sublimation ribbons for P330*i* are specifically designed for your P330*i* Printer.

1. Place the printer power switch in the OFF (0) position.
2. If the printer’s Main Cover is closed:
 - a. Open the printer’s Main Cover; lift it by the lip at the bottom front as shown in the figure below left.

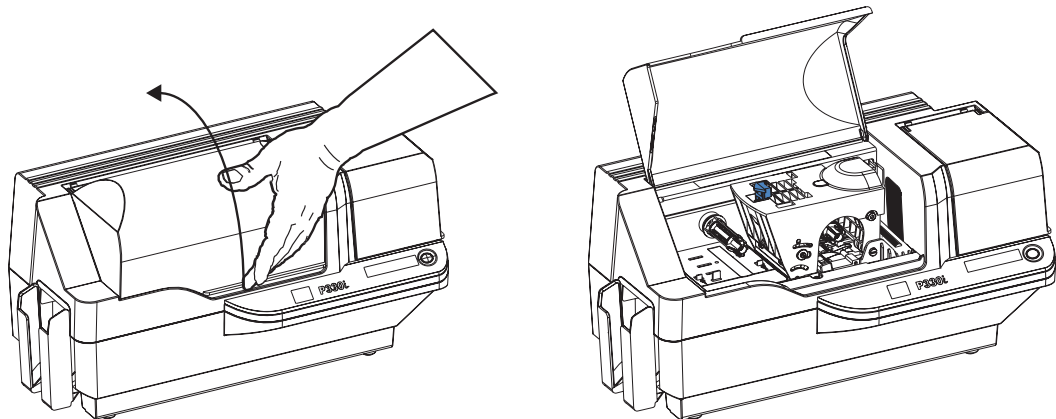

Electrostatic Discharge Caution • DO NOT TOUCH the Print Head or the electronic components on the Print Head Carriage. Discharges of electro-static energy that accumulate on the human body or other surfaces can damage the Print Head or other electronic components used in the printer.



Note • Avoid any direct contact with the print head to prevent transfer of oils or contamination. Outside of normal operation, only the Zebra-approved cleaning materials should come in contact with the print head.

- b. Raise the Print Head Carriage by pressing the release latch to the left (toward the output hopper) and lifting as shown below to about a 45° angle. The Print Head Carriage will stay in that position, as shown at the right below.

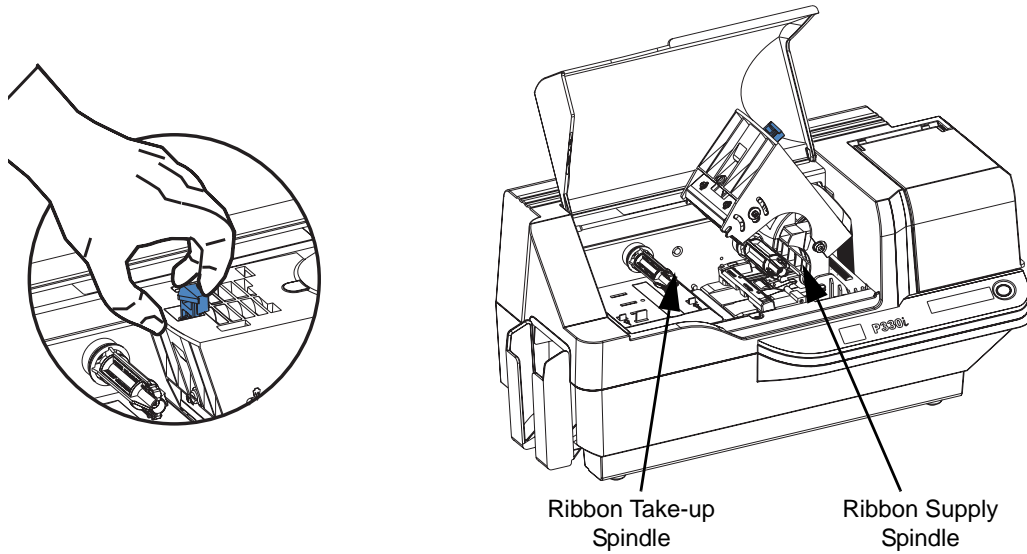

3. Locate the Ribbon Supply Spindle and the Ribbon Take-up Spindle (see above). Load ribbon onto the supply spindle (under the print head carriage) **flange side in**, and load the empty core (with tape attached) onto the take-up spindle. Make sure the ribbon comes off the top of the supply spindle and feeds to the top of the take-up spindle.

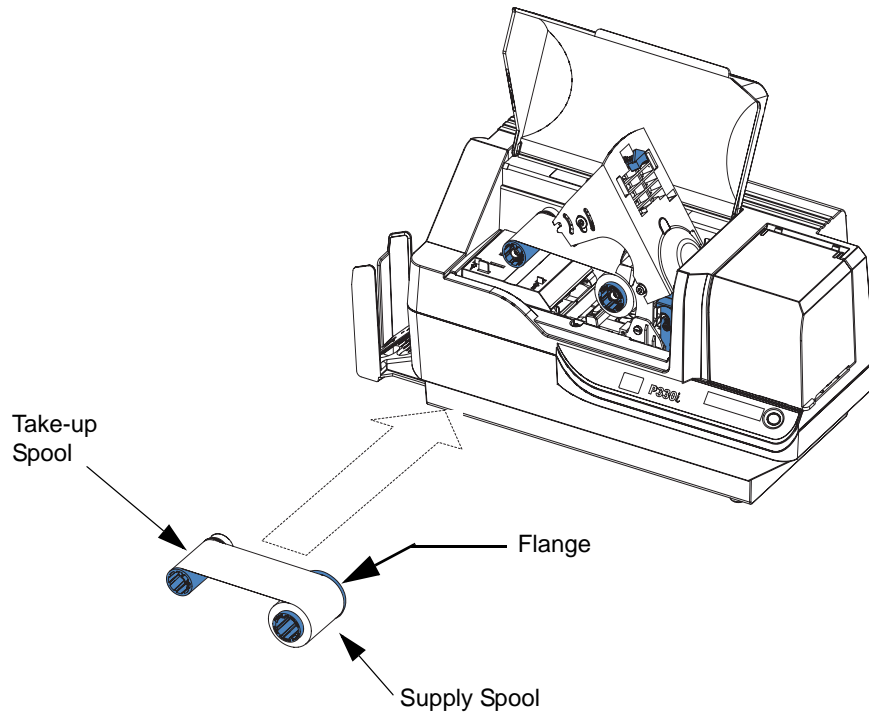



Caution • Do not touch the print head if the printer has been in service within the last 10 minutes. It could be very hot and cause a burn.



Electrostatic Discharge Caution • A static discharge is possible if you touch any exposed metal parts. Use of an anti-static wrist strap or comparable anti-static protection is required.

4. Gently press the print head carriage down until it is fully lowered, as shown below. Very little force is necessary to perform this step.

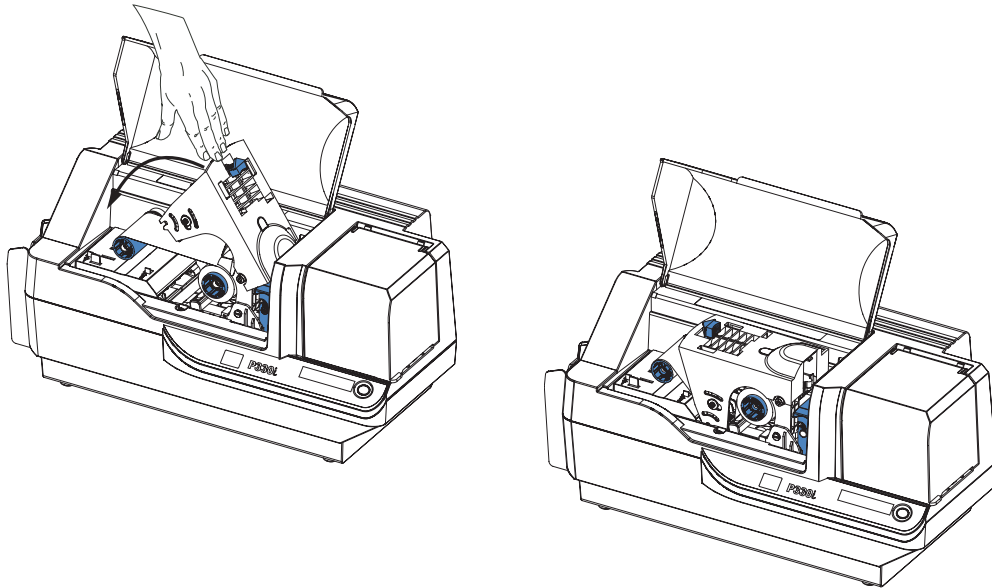

Note • During normal operation (with power connected and turned on), the ribbon would automatically synchronize when the Print Head is restored to its fully-down position. The ribbon would be identified and the corresponding parameters sent to the driver.

Since power is not connected at this point in the Installation and Setup Procedure, nothing will happen when the Print Head Carriage is closed. The ribbon will synchronize when power is turned on.

Installing the Card Cleaning Cartridge

The Card Cleaning Cartridge cleans the cards entering the printer. The Card Cleaning Cartridge consists of a Cartridge Frame and an Adhesive Roller, which are packed together.

1. Remove the Cartridge Frame and the Adhesive Roller from their packaging. Insert the Adhesive Roller into the Cartridge Frame, as shown below. To avoid contamination, always hold the frame and the roller by the ends.

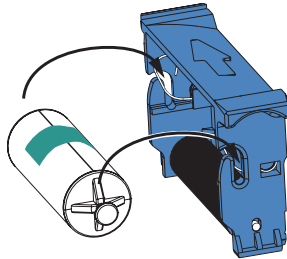

2. Peel the protective wrapper from the Adhesive Roller.

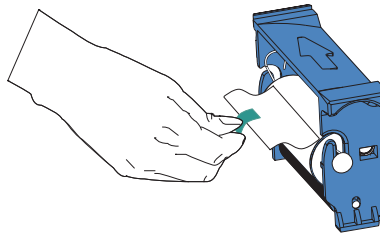

3. If the printer's main cover is closed, open it. Locate the area where the Card Cleaning Cartridge will be installed (initially, this area was covered by a warning tape).

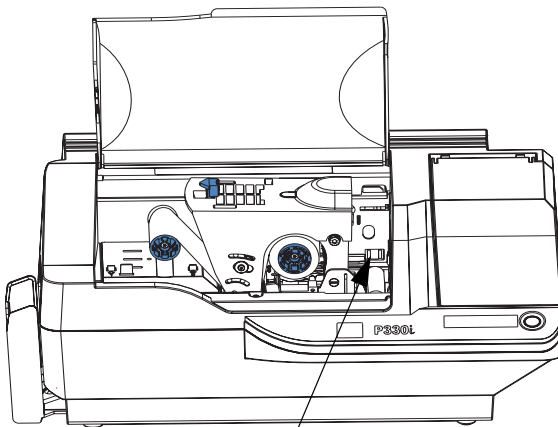

Card Cleaning
Cartridge Mounting
Location

4. Locate the slot at the rear of the Card Cleaning Cartridge mounting location; see below.

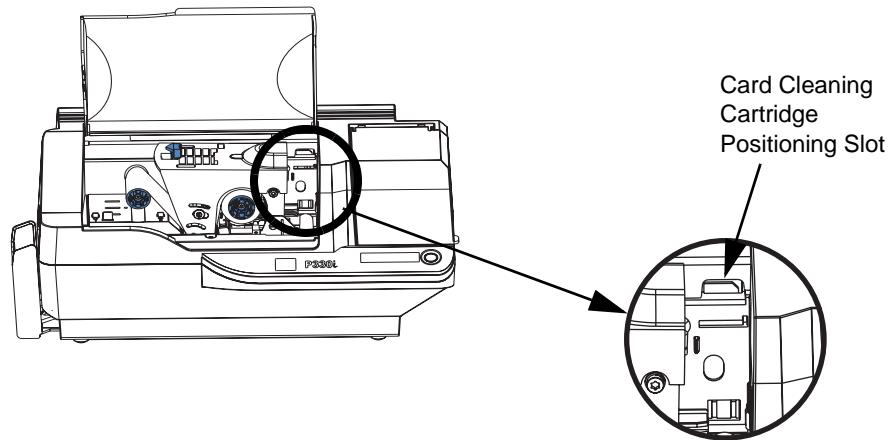

5. Hold the Card Cleaning Cartridge by the extended “handle” (so the large arrow on the top is pointing away from you). With the cartridge at about a 30° angle (pointing downward), insert the lip of the cartridge into the slot, until the cartridge seats against the back wall. Then press the front of the cartridge down until it seats all the way down and latches with an audible “click”. See below.

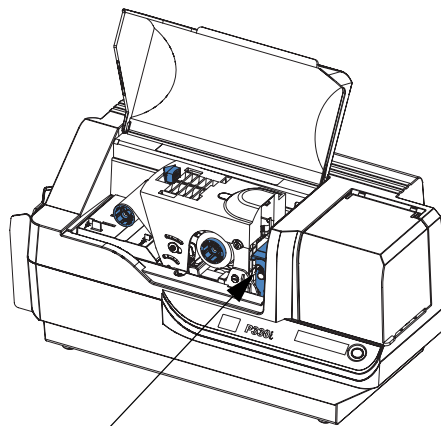
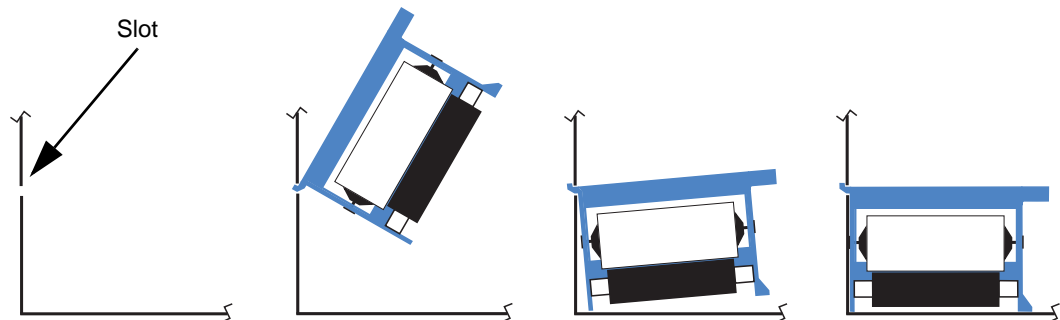

Card Cleaning Cartridge in final position

6. Close the printer's Main Cover.

Setting the Card Thickness Control

The Card Thickness Control is set by the user to adjust the gap as cards enter the printer, to prevent double-feeds (which could cause a jam) or mis-feeds.



Note • Set the Card Thickness Control before loading cards.

1. Open the Card Feeder cover. The cover is hinged; lift it by the lip at the right front corner.



Note • To reduce contamination and ensure better print quality, minimize the time the Card Feeder cover is open.

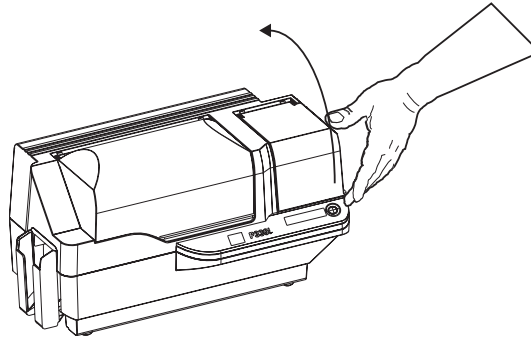

2. The Card Thickness Control Lever is at the front of the left-side opening of the Card Feeder area.

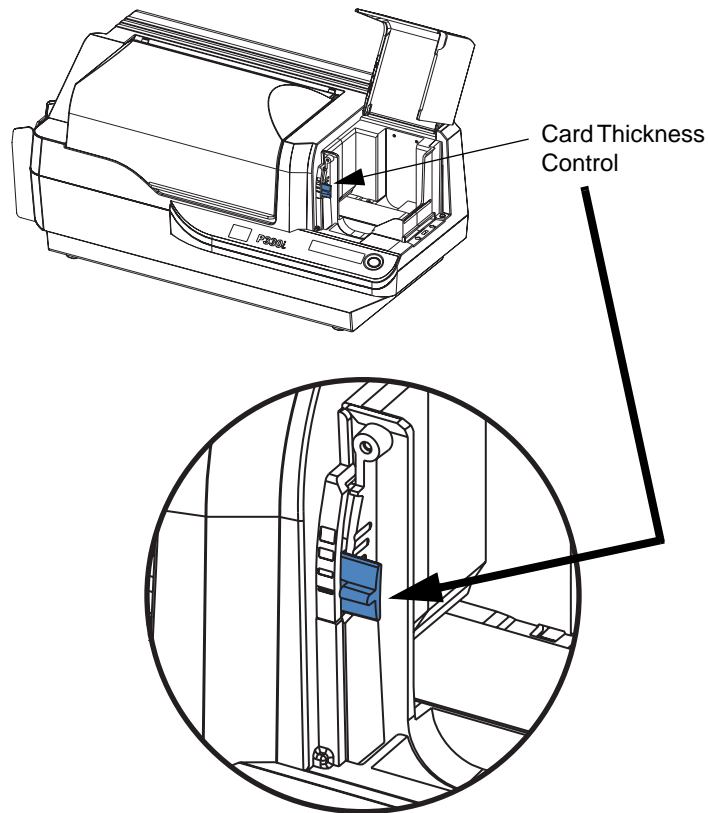

3. There are four detents to set the position of the Card Thickness Control. Slide the Card Thickness Control to the position corresponding to the following:

Detent Position	Card Thickness
Highest	50 mil (1.27 mm) to 60 mil (1.52 mm)
3rd position	30 mil (0.76 mm) to 50 mil (1.27 mm)
2nd position	20 mil (0.51 mm) to 40 mil (1.02 mm)
Lowest	10 mil (0.25 mm) to 20 mil (0.51 mm)



Note • The overlap in settings above accommodates variations in environmental conditions (especially humidity) and cards from different manufacturers. In general, start at the lowest position and move the lever up until cards feed reliably.



Note • “60 mil” (“1.524 mm”) cards may have a significant variation (over 10%) in the actual thickness of the cards; do not use these cards unless each card has been measured to have a thickness less than 66 mil (1.676 mm).

Loading Cards

This section shows how to load plastic cards into the P330i Printer. The P330i can use cards with a range of thickness from 10 mil (0.25 mm) to 60 mil (1.5 mm).



Note • Do not mix cards of different thicknesses!

The P330i Printer can also load and print cards fed individually. Information on this is given in the next chapter.



Note • DO NOT bend cards or touch print surfaces as this can reduce print quality. The surface of the cards must remain clean and dust free. Always store cards in an enclosed container. Ideally, use cards as soon as possible.



Note • For cards with magnetic stripe, refer to Appendix A for loading instructions.

The plastic cards generally come in decks of 100 cards; the Card Feeder can hold a full deck of 100 30-mil cards. Cards sometimes will stick together; this can cause mis-feeding or double-feeding. To avoid this, separate the cards before loading, as described in steps 2 through 4 below.

1. If the Card Feeder cover is closed, open it. The cover is hinged; lift it by the lip at the right front corner.



Note • To reduce contamination and ensure better print quality, minimize the time the Card Feeder cover is open.

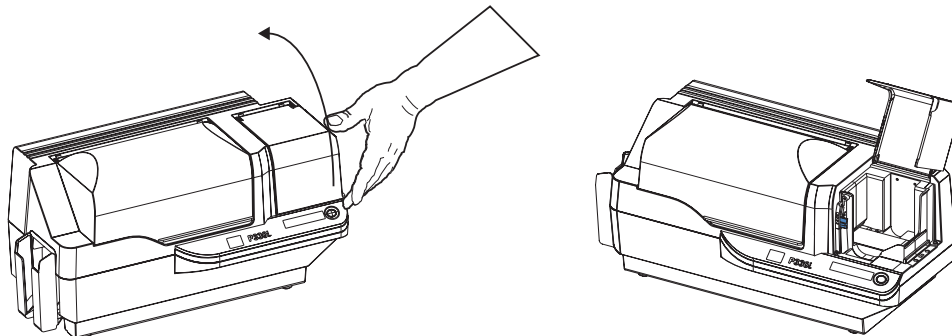



Caution • Do not touch print surfaces of the cards; this can reduce print quality

2. Remove all wrapping from the card deck.
3. Holding the card deck by the sides, hold it vertically against a flat surface such as a desktop. If the deck is too thick for your hand to hold it comfortably, use about half a deck at a time.

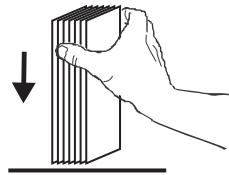

4. Push the stack back and forth to an angle of about 45° from vertical, so as to separate all of the cards.

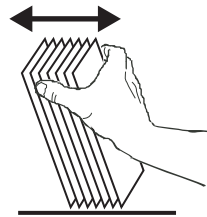

Note • Static charges and edge burrs from the card die-cutting process can render individual cards stuck together with significant adhesion force. These cards must be physically separated from each other before inserting into the feeder; if not separated, feeding or printing problems may occur.

5. Restore the card stack to its original squared-off condition, and place the cards in the input hopper.

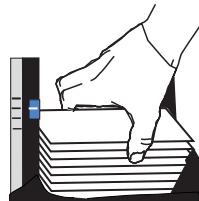

6. Note that there will be a “gap” in the card stack, with several cards lying flat and the cards above angled upward, as shown in the exaggerated drawing below. **This is normal** and ensures proper feeding.

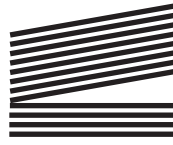

Note • Do not try to eliminate the gap by pressing down on the card stack in the input hopper; this can cause misfeeds.

Card Output Hopper

The card output hopper is normally extended to receive the printed cards. The printer may be operated with the card output hopper in its closed position; in this case the cards will not be collected in the output hopper.

1. Pull the card output hopper out to place it in its functional position.



Note • The output hopper is a very snug fit to prevent it from moving during shipping or operation; firm force is required to change its position.

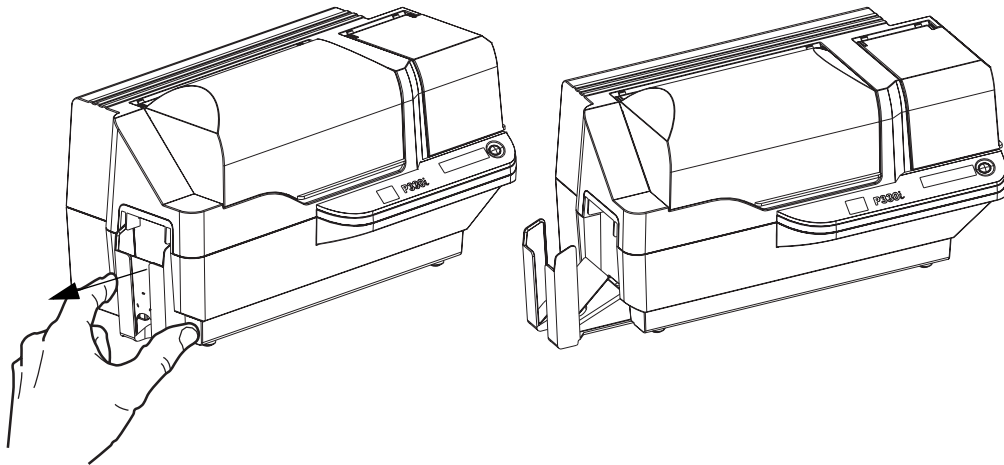

2. When not using the printer, slide the card output hopper back into its closed position to protect the printer from dust and protect the output hopper from damage.
3. The output hopper can be completely removed from the printer if necessary by inserting a thin, blunt object (such as a pencil) up through the hole in the bottom of the printer enclosure and pressing (up) to release the hopper while simultaneously pulling the hopper out. To re-install the output hopper, simply slide the output hopper in until it locks in place.

Connecting the Printer to your Computer

The P330i Printer includes a standard USB interface.

As an option, the printer can be ordered with a 10/100base-T Ethernet Adapter (in addition to the USB interface). The Ethernet Adapter can also be ordered as an add-on option and installed in the field by a Zebra factory certified technician.

1. If using the USB interface, use the supplied USB cable to connect between the USB connector on the printer and a USB port on the computer, as shown below. (Note that the figure below shows the optional Ethernet Adapter directly above the USB Connector; this may not be present on your printer.)

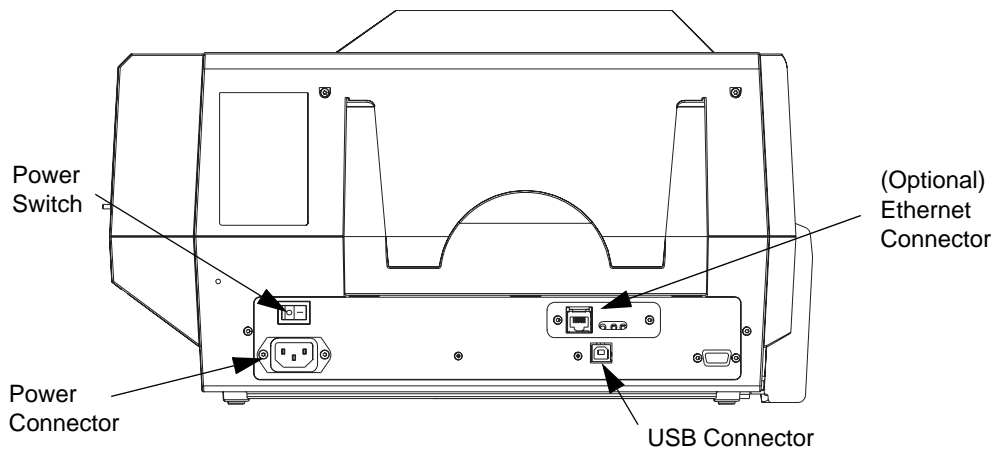

2. If your printer includes the optional Ethernet Adapter as well as the standard USB connection, use **either** the supplied USB cable or a standard Ethernet cable to connect the printer to a corresponding port on the computer or network.



Important • Do not use both USB and Ethernet connections at the same time!



Important • Intermittent or unpredictable operation may occur from unsecured connectors. If damaged, the power cable must be replaced by an exact equivalent.

Connecting Power

The P330i Printer includes an internal AC power supply that accepts nominal input voltage in the range from 110 to 230 volts at 50 to 60 Hertz. The power source must be grounded.

Depending on specific model number, your P330i Printer will include one or two power cords; use the one that is appropriate for the AC power source connection at your location. If neither has an appropriate connector, AC power cords may be purchased locally; make sure it is a three-wire (grounded) cord.

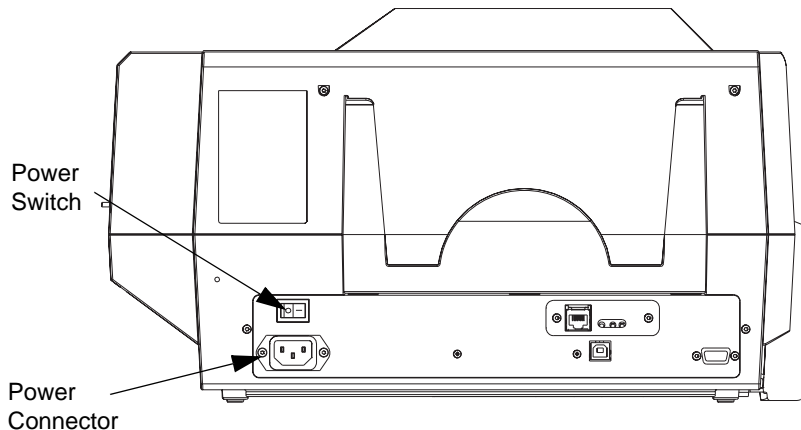

1. Place the Printer's power switch in the OFF (**O**) position.
2. Depending on your local AC voltage, plug the appropriate power cord into the printer's power connector and a grounded AC power source connection.



Caution • If the power cord appears damaged in any way, or if the power cord will not securely plug into the Printer's power connector or the AC power source connection, **STOP!** Use of a damaged or incorrect power cord could cause equipment damage, result in an electrical fire, or possibly cause injury.

3. To turn the Printer on, set the Printer's power switch to the ON (**|**) position.

Printing a Test Card

With ribbon and cards loaded, your P330i Printer is ready to print. To check the operation of the printer, you should print a test card. (Printing a test card does not require that the printer be connected to your computer or network, but power must be applied.)

1. Set the printer's power switch (on the back of the printer) to the OFF (**O**) position.
2. While pressing the Printer's front panel button (next to the LCD display panel), switch the printer ON (**I**).
3. Hold the panel button until the LCD display panel reads "SELF TEST".
4. Release the panel button, and the test card will print.

This is an example of the test card:

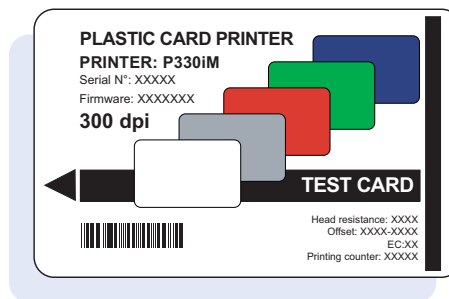

Packing the P330i Printer for Shipment

If the P330i Printer is to be shipped, it is important to use the original packing and shipping material to prevent damage to the Printer. If the original material is lost, a replacement Shipping Kit can be ordered from Zebra; please refer to the Media List on the Windows Drivers and User Documentation CD supplied with this printer.



Note • The specifics of the shipment and the printer's condition may influence which of the following steps are followed; common sense should prevail.

1. Remove cards in the card feeder:
 - a. While the printer still has power applied and is turned on, and is still connected to the host computer, remove cards from the card feeder. The last card may be difficult to remove. If so, use the Eject Card command available through the driver on the host computer to eject the last card that is staged in the feeder.



Caution • Do not physically pull the last card out of the feeder staging area. This could damage the printer and void the warranty, as well as damage the card.

- b. Close the Card Feeder Cover.

Installation and Setup

Packing the P330i Printer for Shipment

2. If the printer still has power applied and is turned on, and is still connected to the host computer, set the printer's power switch (on the back of the printer) to the OFF (**O**) position, and disconnect the interface and power cables to the printer.
3. Open the Main Cover. Open the Print Head Carriage and remove the Ribbon. (If you wish to save the ribbon for future use, you may want to put it in a plastic bag for storage.)
4. Insert the print head protection pad, and close the Print Head Carriage. Remove the Card Cleaning Cartridge and place it in the upper foam insert. Close the Main Cover.
5. Slide the Output Hopper in all the way against the Printer.
6. Place the Printer in its protective plastic bag.
7. Place the lower foam insert in the lower part of the shipping carton.
8. Use both hands to carefully place the Printer into the recess in the lower foam insert.
9. Place the upper foam insert onto the Printer and gently press it down so it makes a snug fit on the Printer; the top of the upper foam insert should be even with the upper edge of the lower part of the shipping carton.
10. Slide the upper part of the shipping carton down over the lower part.
11. Insert and close the handles/latches.



Printing a Card

Printing with the P330i Card Printer is similar to printing with any other printer in a Windows environment.

- The Printer Driver Software is installed on your computer (see Chapter 2).
- The P330i Printer is connected to the power source and the computer (see Chapter 2).
- The P330i Printer is selected by either the Operating System or the appropriate application software program.
- Printer Properties are set (the factory default values will be appropriate for many applications).
- Card printing is directed by the appropriate application software program.

Setting Printer Properties

Printer Properties can be set either at the Operating System level or within the application software program used for printing cards.



Note • In the following description of setting Printer Properties, only those properties and options that are suitable for being set by the User are described. The User should not make selections or set parameters unless they are specifically described in this section

Preferences settings can configure the P330i Card Printer for Landscape (wide) or Portrait (tall) printing orientation, and allow the user to verify that the desired ribbon is installed in the printer. (Monochrome ribbons are selected via the drop-down menu.)

If the P330i Printer includes the optional magnetic card stripe encoder, encoding parameters and coercivity can be set.

Printer cleaning can be initiated from the Tools window (printer cleaning can also be initiated at the printer; see Chapter 4).

Printing a Card

Printing a Sample Card

Also from the Tools window, the Test Card can be selected from several pre-loaded styles.

“Single Feed Options” allows Disabling or Enabling Single Feed Support.

- If “Disable Single Feed Support” is selected, when the P330i Card Printer runs out of cards in the feeder, the LCD display will read OUT OF CARDS. To continue, press the panel button.
- If “Enable Single Feed Support” is selected, when the P330i Card Printer runs out of cards in the feeder it will wait until a card is inserted in the single-card slot or cards are loaded in the feeder, and then will automatically continue.

Printing a Sample Card

Sample card designs are installed with the printer driver. Sample cards require Microsoft Word or Microsoft Paint application software. The cards are accessed via the Start menu. Select Start, select Programs, select Zebra Card Printers, and select a sample card, or follow the directions below to design a card.

Follow these steps to design and print your first card:

1. Launch Microsoft Word Software. Depending on your computer configuration this may be done by double-clicking an icon on your desktop, or by clicking the Windows Start icon, selecting Programs, and navigating to Microsoft Word
2. Go to the **File** menu and choose **Page Setup**.
3. Select the **Paper Size** tab, choose **Card**. Under orientation, select **Landscape**.
4. Select the **Margins** tab, and set the Top, Bottom, Left, and Right margins to 0 (zero).
5. Click **OK** to close the **Page Setup** window.
6. The card appears on the screen.
7. Design a card with both black and colored text and with colored pictures (see example below).

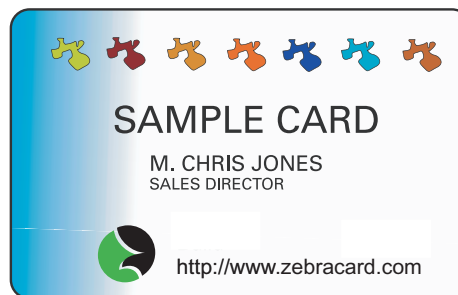



Note • For cards thinner than 20 mils (0.51 mm), the card design must be limited to (1) no more than two 30 mm x 30 mm areas of full color, (2) black information (text and barcode, for example) must cover no more than 50% of the card area, and (3) there must be at least a 5mm unprinted border along all edges.

For cards thicker than 40 mils (1.02 mm), the card design must have at least a 5mm unprinted border along all edges.

For cards with thickness between 20 mils (0.51 mm) and 40 mils (1.02 mm), these restrictions do not apply; full color printing is permitted edge to edge in both directions.

8. Once you are ready to print, go to the **File** menu and select **Print**.
9. If the printer was not selected as the default printer, go to the File menu, select **Print Setup** and choose **Zebra P330i Card Printer** from the printer names list. Then **Close** the **Print Setup** dialog box.
10. The printer will feed in a card and start printing (the data download time will vary depending on the complexity of the card design and the processing speed of your computer).
11. Once the printing job is complete, the card is ejected from the printer.

Feeding One Card at a Time

A Manual Feed Slot is available below the Card Input Hopper for feeding single cards. The Card Input Hopper must be empty for single-card feeding to work properly.

1. Open the Card Feeder cover. Verify that there are no cards in the feeder, then close the Card Feeder cover.
2. Insert a single card into the slot below the Card Feeder. Do not feed more than one card at a time.

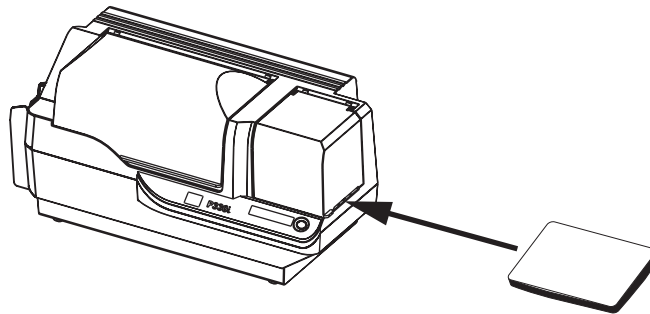

Note • If single-card feeding will be the normal mode of operation, you may select that mode through the driver software. In single-card feed mode, the card will not be printed until the print job has been sent to the printer and the card to be printed has been inserted into the single-card feed slot

Printing a Card
Feeding One Card at a Time

