

Installing the Card Cleaning Cartridge

The Card Cleaning Cartridge cleans the cards entering the printer. The Card Cleaning Cartridge consists of a Cartridge Frame and an Adhesive Roller, which are packed together.

1. Remove the Cartridge Frame and the Adhesive Roller from their packaging. Insert the Adhesive Roller into the Cartridge Frame, as shown below. To avoid contamination, always hold the frame and the roller by the ends.

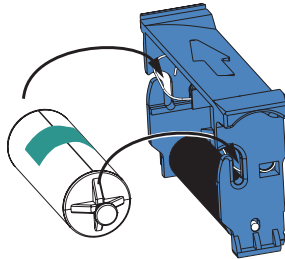

2. Peel the protective wrapper from the Adhesive Roller.

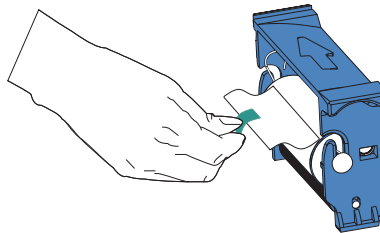

3. If the printer's main cover is closed, open it. Locate the area where the Card Cleaning Cartridge will be installed (initially, this area was covered by a warning tape).

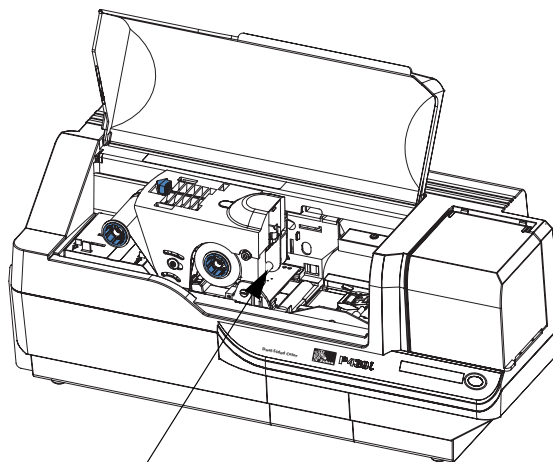

Card Cleaning
Cartridge Mounting
Location

4. Locate the slot at the rear of the Card Cleaning Cartridge mounting location; see below.

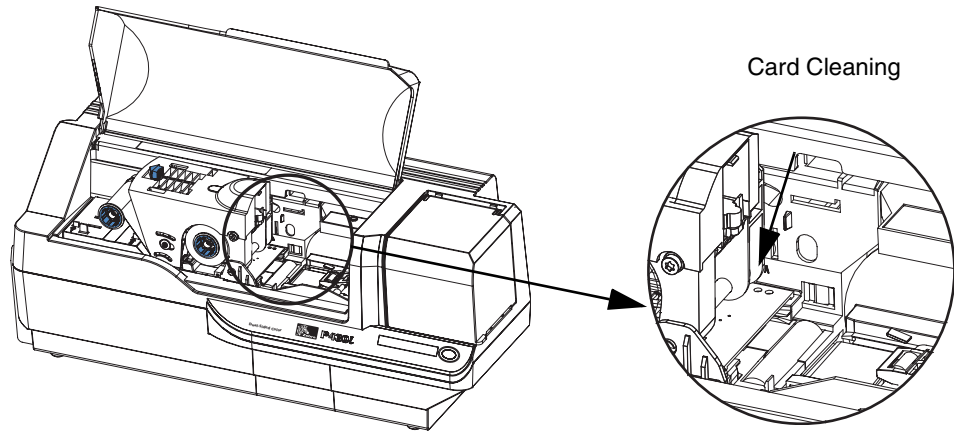

5. Hold the Card Cleaning Cartridge by the extended “handle” (so the large arrow on the top is pointing away from you). With the cartridge at about a 30° angle (pointing downward), insert the lip of the cartridge into the slot, until the cartridge seats against the back wall. Then press the front of the cartridge down until it seats all the way down and latches with an audible “click”. See below.

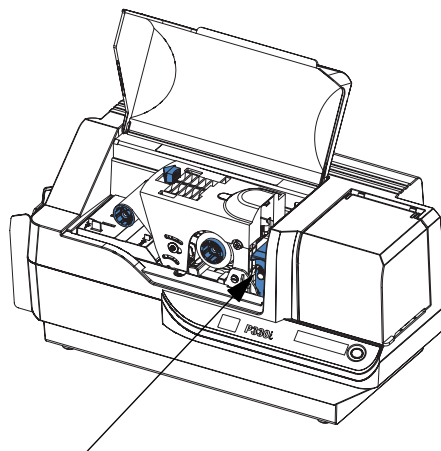
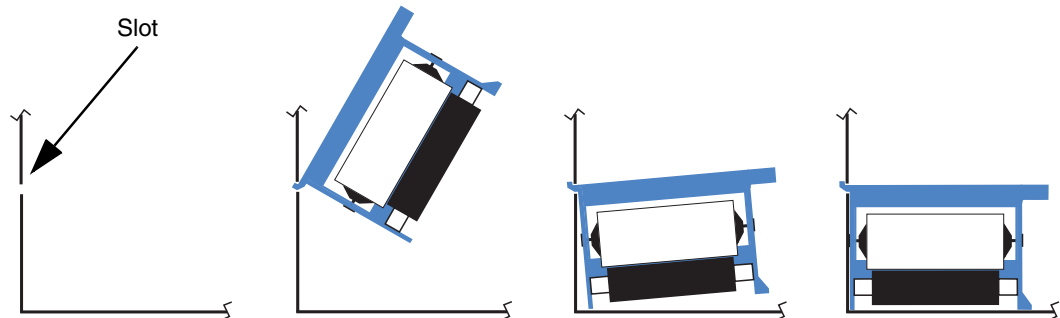

Card Cleaning Cartridge in final position

6. Close the printer's Main Cover.

Setting the Card Thickness Control

The Card Thickness Control is set by the user to adjust the gap as cards enter the printer, to prevent double-feeds (which could cause a jam) or mis-feeds.



Note • Set the Card Thickness Control before loading cards.

1. Open the Card Feeder cover. The cover is hinged; lift it by the lip at the right front corner.



Note • To reduce contamination and ensure better print quality, minimize the time the Card Feeder cover is open.

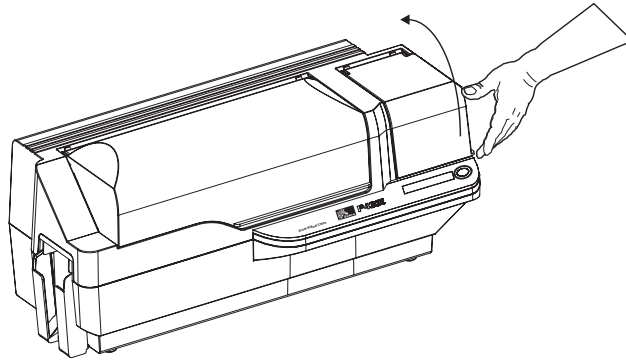

2. The Card Thickness Control Lever is at the front of the left-side opening of the Card Feeder area.

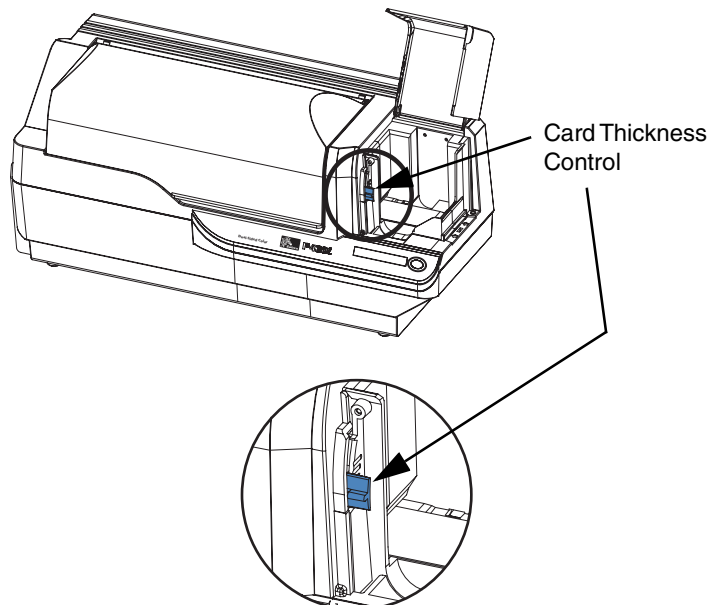

3. There are four detents to set the position of the Card Thickness Control. Slide the Card Thickness Control to the position corresponding to the following:

Detent Position	Card Thickness
Highest	50 mil (1.27 mm) to 60 mil (1.52 mm)
3rd position	30 mil (0.76 mm) to 50 mil (1.27 mm)
2nd position	20 mil (0.51 mm) to 40 mil (1.02 mm)
Lowest	10 mil (0.25 mm) to 20 mil (0.51 mm)



Note • The overlap in settings above accomodates variations in environmental conditions (especially humidity) and cards from different manufacturers. In general, start at the lowest position and move the lever up until cards feed reliably.



Note • “60 mil” (“1.524 mm”) cards may have a significant variation (over 10%) in the actual thickness of the cards; do not use these cards unless each card has been measured to have a thickness less than 66 mil (1.676 mm).

Loading Cards

This section shows how to load plastic cards into the P430i Printer. The P430i can use cards with a range of thickness from 10 mil (0.25 mm) to 60 mil (1.5 mm).



Note • Do not mix cards of different thicknesses!

The P430i Printer can also load and print cards fed individually. Information on this is given in the next chapter.



Note • DO NOT bend cards or touch print surfaces as this can reduce print quality. The surface of the cards must remain clean and dust free. Always store cards in an enclosed container. Ideally, use cards as soon as possible.



Note • For cards with magnetic stripe, refer to Appendix A for loading instructions.

The plastic cards generally come in decks of 100 cards; the Card Feeder can hold a full deck of 100 30-mil cards. Cards sometimes will stick together; this can cause mis-feeding or double-feeding. To avoid this, separate the cards before loading, as described in steps 2 through 4 below.

1. If the Card Feeder cover is closed, open it. The cover is hinged; lift it by the lip at the right front corner.



Note • To reduce contamination and ensure better print quality, minimize the time the Card Feeder cover is open.

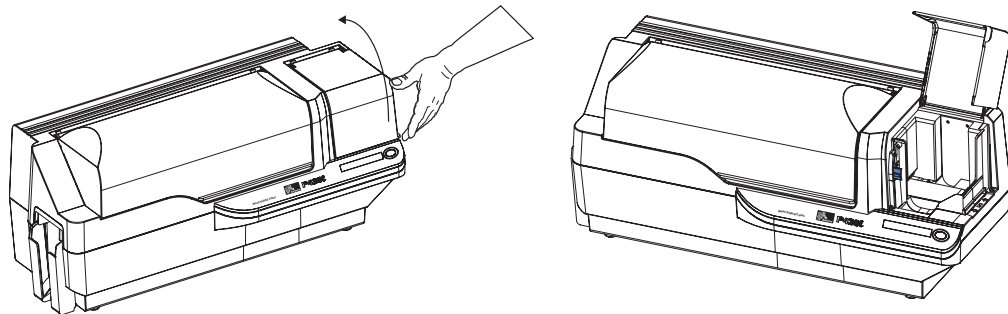



Caution • Do not touch print surfaces of the cards; this can reduce print quality

2. Remove all wrapping from the card deck.
3. Holding the card deck by the sides, hold it vertically against a flat surface such as a desktop. If the deck is too thick for your hand to hold it comfortably, use about half a deck at a time.

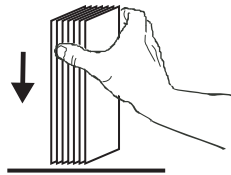

4. Push the stack back and forth to an angle of about 45° from vertical, so as to separate all of the cards.

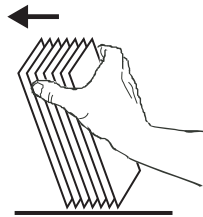

Note • Static charges and edge burrs from the card die-cutting process can render individual cards stuck together with significant adhesion force. These cards must be physically separated from each other before inserting into the feeder; if not separated, feeding or printing problems may occur.

5. Restore the card stack to its original squared-off condition, and place the cards in the input hopper.



6. Note that there will be a “gap” in the card stack, with several cards lying flat and the cards above angled upward, as shown in the exaggerated drawing below. **This is normal** and ensures proper feeding.



Note • Do not try to eliminate the gap by pressing down on the card stack in the input hopper; this can cause misfeeds.

Card Output Hopper

The card output hopper is normally extended to receive the printed cards. The printer may be operated with the card output hopper in its closed position; in this case the cards will not be collected in the output hopper.

1. Pull the card output hopper out to place it in its functional position.



Note • The output hopper is a very snug fit to prevent it from moving during shipping or operation; firm force is required to change its position.

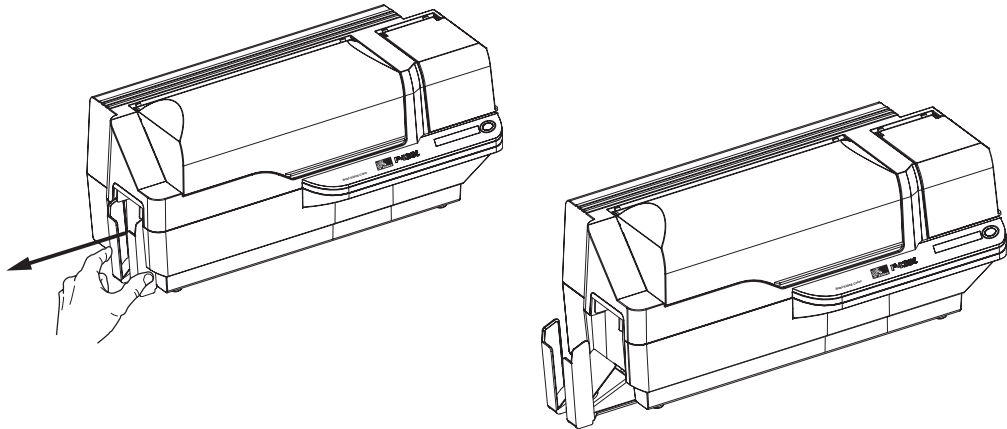

2. When not using the printer, slide the card output hopper back into its closed position to protect the printer from dust and protect the output hopper from damage.
3. The output hopper can be completely removed from the printer if necessary by inserting a thin, blunt object (such as a pencil) up through the hole in the bottom of the printer enclosure and pressing (up) to release the hopper while simultaneously pulling the hopper out. To re-install the output hopper, simply slide the output hopper in until it locks in place.

Connecting the Printer to your Computer

The P430i Printer includes a standard USB interface.

As an option, the printer can be ordered with a 10/100base-T Ethernet Adapter (in addition to the USB interface). The Ethernet Adapter can also be ordered as an add-on option and installed in the field by a Zebra factory certified technician.

1. If using the USB interface, use the supplied USB cable to connect between the USB connector on the printer and a USB port on the computer, as shown below. (Note that the figure below shows the optional Ethernet Adapter directly above the USB Connector; this may not be present on your printer.)

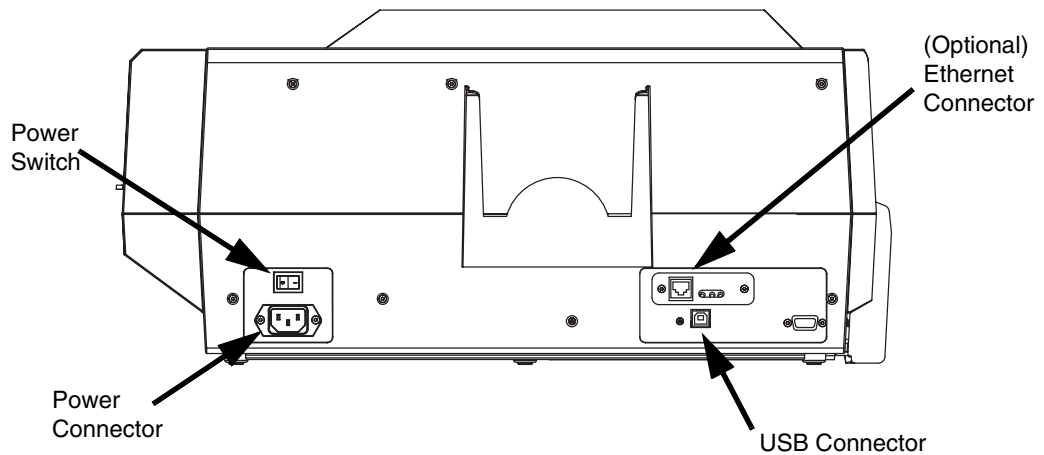

2. If your printer includes the optional Ethernet Adapter as well as the standard USB connection, use **either** the supplied USB cable or a standard Ethernet cable to connect the printer to a corresponding port on the computer or network.



Important • Do not use both USB and Ethernet connections at the same time!



Important • Intermittent or unpredictable operation may occur from unsecured connectors. If damaged, the power cable must be replaced by an exact equivalent.

Connecting Power

The P430i Printer includes an internal AC power supply that accepts nominal input voltage in the range from 110 to 230 volts at 50 to 60 Hertz. The power source must be grounded.

Depending on specific model number, your P430i Printer will include one or two power cords; use the one that is appropriate for the AC power source connection at your location. If neither has an appropriate connector, AC power cords may be purchased locally; make sure it is a three-wire (grounded) cord.

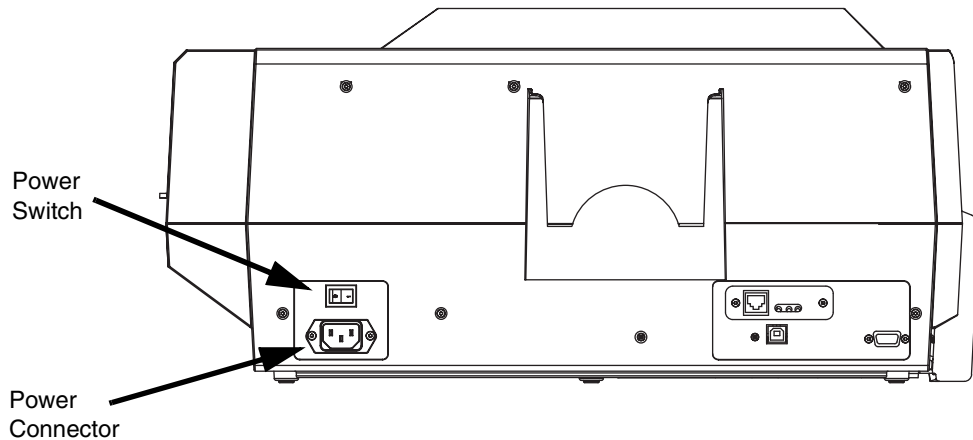

1. Place the Printer's power switch in the OFF (O) position.
2. Depending on your local AC voltage, plug the appropriate power cord into the printer's power connector and a grounded AC power source connection.



Caution • If the power cord appears damaged in any way, or if the power cord will not securely plug into the Printer's power connector or the AC power source connection, **STOP!** Use of a damaged or incorrect power cord could cause equipment damage, result in an electrical fire, or possibly cause injury.

3. To turn the Printer on, set the Printer's power switch to the ON (I) position.

Printing a Test Card

With ribbon and cards loaded, your P430i Printer is ready to print. To check the operation of the printer, you should print a test card. (Printing a test card does not require that the printer be connected to your computer or network, but power must be applied.)

1. Set the printer's power switch (on the back of the printer) to the OFF (**O**) position.
2. While pressing the Printer's front panel button (next to the LCD display panel), switch the printer ON (**I**).
3. Hold the panel button until the LCD display panel reads "SELF TEST".
4. Release the panel button, and the test card will print.

This is an example of the test card:

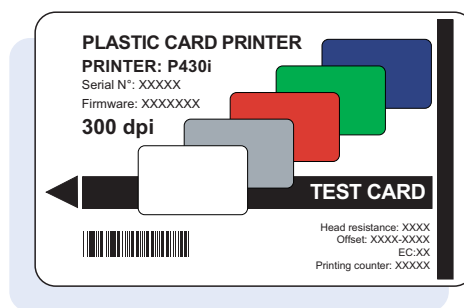

Packing the P430i Printer for Shipment

If the P430i Printer is to be shipped, it is important to use the original packing and shipping material to prevent damage to the Printer. If the original material is lost, a replacement Shipping Kit can be ordered from Zebra; please refer to the Media List on the Windows Drivers and User Documentation CD supplied with this printer.



Note • The specifics of the shipment and the printer's condition may influence which of the following steps are followed; common sense should prevail.

1. Remove cards in the card feeder:
 - a. While the printer still has power applied and is turned on, and is still connected to the host computer, remove cards from the card feeder. The last card may be difficult to remove. If so, use the Eject Card command available through the driver on the host computer to eject the last card that is staged in the feeder.



Caution • Do not physically pull the last card out of the feeder staging area. This could damage the printer and void the warranty, as well as damage the card.

- b. Close the Card Feeder Cover.

Installation and Setup

Packing the P430i Printer for Shipment

- 2.** If the printer still has power applied and is turned on, and is still connected to the host computer, set the printer's power switch (on the back of the printer) to the OFF (**O**) position, and disconnect the interface and power cables to the printer.
- 3.** Open the Main Cover. Open the Print Head Carriage and remove the Ribbon. (If you wish to save the ribbon for future use, you may want to put it in a plastic bag for storage.)
- 4.** Insert the print head protection pad, and close the Print Head Carriage. Remove the Card Cleaning Cartridge and place it in the upper foam insert. Close the Main Cover.
- 5.** Slide the Output Hopper in all the way against the Printer.
- 6.** Place the Printer in its protective plastic bag.
- 7.** Place the lower foam insert in the lower part of the shipping carton.
- 8.** Use both hands to carefully place the Printer into the recess in the lower foam insert.
- 9.** Place the upper foam insert onto the Printer and gently press it down so it makes a snug fit on the Printer; the top of the upper foam insert should be even with the upper edge of the lower part of the shipping carton.
- 10.** Slide the upper part of the shipping carton down over the lower part.
- 11.** Insert and close the handles/latches.



Printing a Card

Printing with the P430i Card Printer is similar to printing with any other printer in a Windows environment.

- The Printer Driver Software is installed on your computer (see Chapter 2).
- The P430i Printer is connected to the power source and the computer (see Chapter 2).
- The P430i Printer is selected by either the Operating System or the appropriate application software program.
- Printer Properties are set (the factory default values will be appropriate for many applications).
- Card printing is directed by the appropriate application software program.

Setting Printer Properties

Printer Properties can be set either at the Operating System level or within the application software program used for printing cards.



Note • In the following description of setting Printer Properties, only those properties and options that are suitable for being set by the User are described. The User should not make selections or set parameters unless they are specifically described in this section

Preferences settings can configure the P430i Card Printer for Landscape (wide) or Portrait (tall) printing orientation, and allow the user to verify that the desired ribbon is installed in the printer. (Monochrome ribbons are selected via the drop-down menu.)

If the P430i Printer includes the optional magnetic card stripe encoder, encoding parameters and coercivity can be set.

Printer cleaning can be initiated from the Tools window (printer cleaning can also be initiated at the printer; see Chapter 4).

Also from the Tools window, the Test Card can be selected from several pre-loaded styles.

“Single Feed Options” allows Disabling or Enabling Single Feed Support.

- If “Disable Single Feed Support” is selected, when the P430i Card Printer runs out of cards in the feeder, the LCD display will read OUT OF CARDS. To continue, press the panel button.
- If “Enable Single Feed Support” is selected, when the P430i Card Printer runs out of cards in the feeder it will wait until a card is inserted in the single-card slot or cards are loaded in the feeder, and then will automatically continue.

Printing a Sample Card

Sample card designs are installed with the printer driver. Sample cards require Microsoft Word or Microsoft Paint application software. The cards are accessed via the Start menu. Select Start, select Programs, select Zebra Card Printers, and select a sample card, or follow the directions below to design a card.

Follow these steps to design and print your first card:

1. Launch Microsoft Word Software. Depending on your computer configuration this may be done by double-clicking an icon on your desktop, or by clicking the Windows Start icon, selecting Programs, and navigating to Microsoft Word
2. Go to the **File** menu and choose **Page Setup**.
3. Select the **Paper Size** tab, choose **Card**. Under orientation, select **Landscape**.
4. Select the **Margins** tab, and set the Top, Bottom, Left, and Right margins to 0 (zero).
5. Click **OK** to close the **Page Setup** window.
6. The card appears on the screen.
7. Design a card with both black and colored text and with colored pictures (see example below).

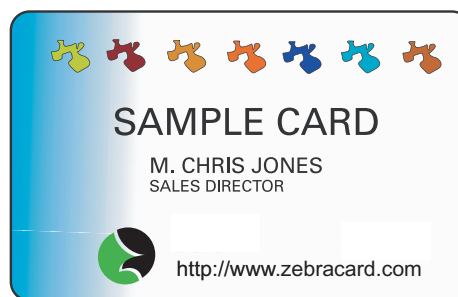

Note • For cards thinner than 20 mils (0.51 mm) or thicker than 40 mils (1.02 mm), the card design must be limited to (1) no more than two 30 mm x 30 mm areas of full color, (2) black information (text and barcode, for example) must cover no more than 50% of the card area, and (3) there must be at least a 5mm unprinted border along all edges.

For cards with thickness between 20 mils (0.51 mm) and 40 mils (1.02 mm), these restrictions do not apply; full color printing is permitted edge to edge in both directions.

8. Once you are ready to print, go to the **File** menu and select **Print**.
9. If the printer was not selected as the default printer, go to the File menu, select **Print Setup** and choose **Zebra P430i Card Printer** from the printer names list. Then **Close** the **Print Setup** dialog box.
10. The printer will feed in a card and start printing (the data download time will vary depending on the complexity of the card design and the processing speed of your computer).
11. Once the printing job is complete, the card is ejected from the printer into the Output Hopper.

Removing Rejected Cards

While encoding either magnetic stripe cards or smart cards, if a card fails encoding it is directed to the reject hopper. The reject hopper has a capacity of about 20 cards. Rejected cards can be removed while the printer remains in normal operation. To remove cards from the reject hopper, press the reject hopper door to open it, and remove the rejected cards. Then close the reject hopper door; it will remain latched in the closed position.

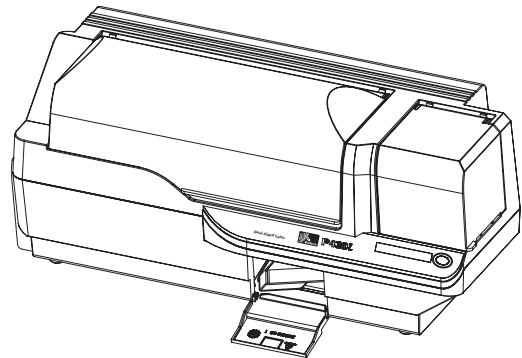
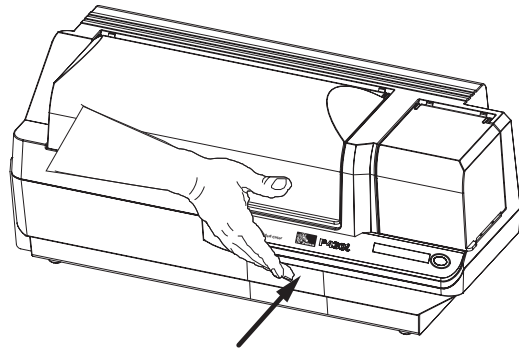

Feeding One Card at a Time

A Manual Feed Slot is available below the Card Input Hopper for feeding single cards. The Card Input Hopper must be empty for single-card feeding to work properly.

1. Open the Card Feeder cover. Verify that there are no cards in the feeder, then close the Card Feeder cover.
2. Insert a single card into the slot below the Card Feeder. Do not feed more than one card at a time.

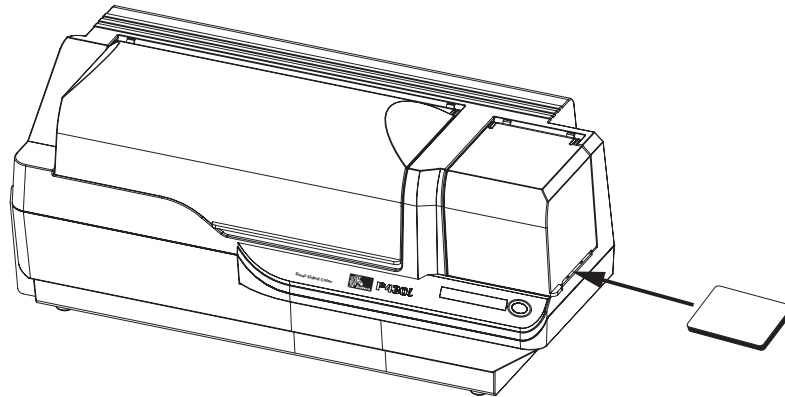

Note • If single-card feeding will be the normal mode of operation, you may select that mode through the driver software. In single-card feed mode, the card will not be printed until the print job has been sent to the printer and the card to be printed has been inserted into the single-card feed slot



Cleaning



Caution • PROTECT YOUR FACTORY WARRANTY!

The recommended cleaning procedures must be performed to maintain your factory warranty. Other than the recommended cleaning procedures described in this manual, allow only Zebra authorized technicians to service the P430i Printer.

NEVER loosen, tighten, adjust, bend, etc., any part or cable inside the printer.

NEVER use a high pressure air compressor to remove particles in the printer.

Cleaning the Printer

Clean your P430i Printer using Pre-Saturated Cleaning Cards provided. The regular use of these cards will clean and maintain important parts of your printer that cannot be reached, including the Print Head, Transport Rollers, and optional Magnetic Encoder Station.

When to Clean

When the LCD Panel displays the message **CLEAN PRINTER**.

Approximately every 1000 cards when using 5-panel color ribbon, or every 5000 cards when using a monochrome ribbon.

How to Clean



Note • This cleaning procedure uses two cleaning cards. One cleaning card is the size of a regular plastic card, and is referred to as the “cleaning card.” The other is elongated, with a wider section at one end; it is referred to as the “long cleaning card.”

1. Leave the Printer power on, or turn it on if it was off.
2. Initiate the cleaning process by either of the following methods:
 - At the printer, press and hold the panel button for several seconds, until the LCD Panel displays the message **REMOVE RIBBON THEN CLOSE HEAD**.
 - From the computer, enter the P430i Printer Tools software, and click on the CLEAN button. The LCD Panel will display the message **REMOVE RIBBON THEN CLOSE HEAD**.
3. Open the Main Cover, release the Print Head Carriage, and remove the ribbon. Then close the Print Head Carriage. (For details, see Chapter 2.) The LCD Panel will display the message **EMPTY FEEDER & PRESS BUTTON**.
4. Open the Card Feeder Cover and remove cards from the Card Feeder. The last card is difficult to remove; leave it in place. Press the Panel Button on the front of the printer. The card remaining in the feeder will be ejected. The LCD Panel will then display the message **LOAD CLEANING CARD IN FEEDER**.
5. Place a pre-saturated Cleaning Card into the Card Feeder. The Cleaning Card will automatically feed into the printer and the cleaning process will start (there is a several second delay after the Cleaning Card feeds before the cleaning movement starts). While the cleaning process is underway, the LCD Panel will display the message **CLEANING PRINTER**.
6. At the conclusion of this part of the cleaning process, the Cleaning Card will be ejected, and the LCD Panel will display the message **PRESS BUTTON TO CONTINUE**.
7. After the user presses the panel button, the LCD Panel will display the message **FEED LONG CLEANING CARD IN EXIT**. Insert the long end of the long cleaning card into the card exit (directly above the Output Hopper). If the user inserts a “regular” cleaning card into the card exit, the LCD Panel will display the message **INVALID CARD, PRESS BUTTON** until the user presses the panel button and inserts the long cleaning card into the card exit.



Note • If the user does nothing at this point (i.e., does not insert the long cleaning card), after a timeout the LCD Panel display will change to **CLEAN PRINTER**. The printer will be able to print, but the LCD Panel will continue to display **CLEAN PRINTER**.

This limited cleaning does not do a thorough cleaning, but may be performed if no “long cleaning cards” are available.

To restore the display to **READY**, you will need to perform a complete cleaning process, using both short and long cleaning cards, from step 2 above through step 9 below.

8. The long cleaning card will automatically feed into the printer and the printing process will continue. The LCD Panel will again display the message **CLEANING PRINTER**.
9. When the cleaning process is completed, the long cleaning card will be ejected and the LCD Panel will display the message **READY**, indicating that the printer is ready to resume normal printing operations.
10. Discard both cleaning cards after a single use.



Note • Do not use previously used cleaning cards.

Cleaning the Print Head

A cleaning using the Cleaning Cards usually suffices. However, a separate Print Head cleaning can remove more stubborn deposits when print anomalies persist. To avoid deposits, only use foam-tipped swabs.

1. Place the printer power switch in the OFF (**O**) position.
2. Open the Main Cover, release the Print Head Carriage, and remove the ribbon. Leave the Print Head Carriage in its raised position. (For details, see Chapter 2.)
3. Clean Print Head by moving an alcohol-moistened swab tip side-to-side across the Print Head elements. Only use moderate force. To re-order swabs, please refer to the Media List on the Windows Drivers and User Documentation CD supplied with this printer.
4. The swabs can also be used in a similar manner to clean the optional magnetic encoding head.



Caution • Never use a sharp object or any abrasive to scrape deposits from the print head. Permanent damage to the print head will result.



Caution • Do not touch the print head if the printer has been in service in the last 10 minutes. It could be very hot and cause a burn.

Card Cleaning Cartridge

Your P430i Printer includes a Card Cleaning Cartridge. This item cleans the cards entering the printer through the card feeder. To ensure print quality, the cleaning roller requires periodic replacement. New cleaning rollers are included with each ribbon or may be purchased separately. (To reorder, please refer to the Media List on the Windows Drivers and User Documentation CD supplied with this printer.)

Installation of the Card Cleaning Cartridge is described in Chapter 2 and is not repeated in detail here.



Note • Before replacing the Card Cleaning Cartridge or its cleaning roller, clean the Printer using the Cleaning Cards as described earlier in this chapter.

When to Replace the Cleaning Roller

Replace the Cleaning Roller each time you install a new ribbon.

How To Replace the Cleaning Roller

1. Open the main cover and locate the Card Cleaning Cartridge.

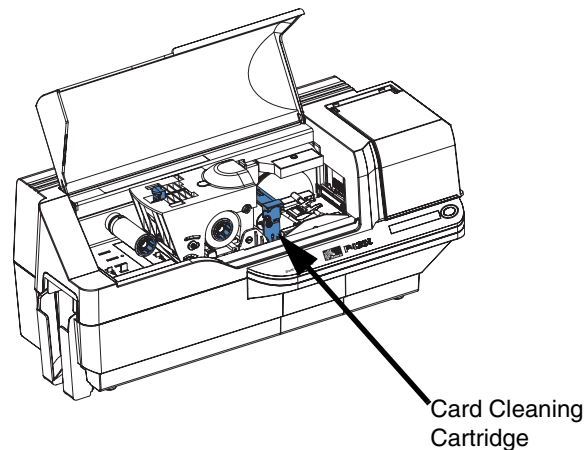

2. Gently remove the Card Cleaning Cartridge. Lift the “handle” end, and then pull it away from the printer.

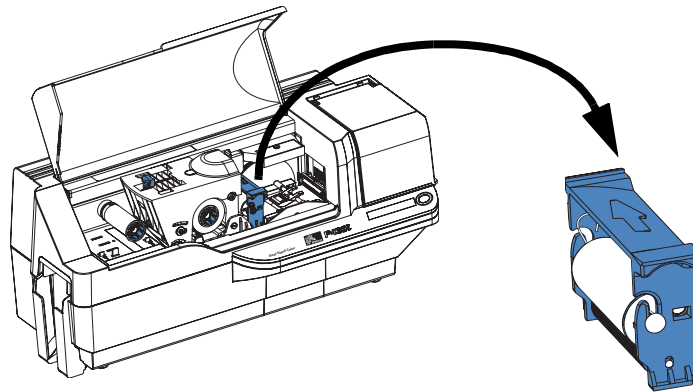

3. Remove the cleaning roller from the Card Cleaning Cartridge and discard.

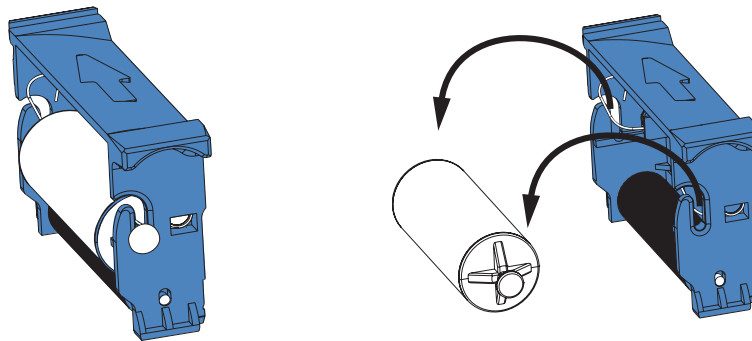

4. Install new cleaning roller into the Card Cleaning Cartridge. To avoid contamination, always hold the cleaning roller by the ends. (For replacement cleaning rollers, please refer to the Media List on the Windows Drivers and User Documentation CD supplied with this printer.)

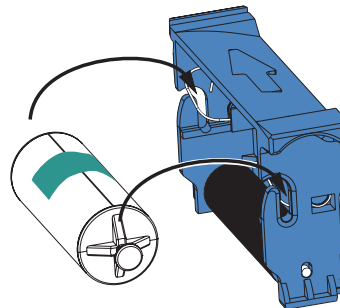

5. Peel protective wrapper from the cleaning roller by gently pulling on the tape.