

Getting Started

This section describes how to set up your printer for the first time and use the most common operating procedures for loading media in tear-off mode and loading ribbon.

Modes of Printing

You can operate this printer in different modes:

- Standard tear-off mode allows you to tear off each label (or a strip of labels) after it is printed.
- In optional peel-off mode, the backing material is peeled away from the label as it is printed. After this label is removed, the next one is printed.
- In optional cutter mode, an attached unit cuts through the media.

The printer typically uses roll media, but you can use fan-fold or other continuous media as well.

For procedures to use optional modes and features, refer to the Operation and Options section.

Attaching Power Supply

Check the power supply to make certain it is appropriate for your input voltage.



Caution • Use the power supply that came with your printer. Never operate the printer and power supply in an area where they can get wet. Serious personal injury could result!

1. Make sure the power switch is in the off position (down).
2. The DC power supply has a barrel connector on one end that must be inserted into the power supply receptacle on the back of the printer.
3. Insert the separate AC power cord into the power supply.
4. Plug the other end of the cord into an appropriate AC electrical outlet.

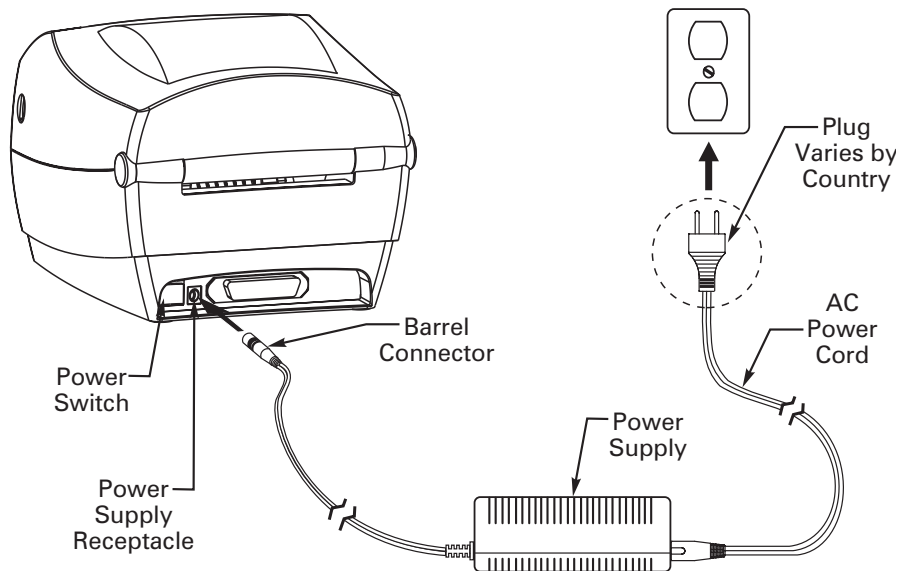

Loading Roll Media



When you load media, you must place the roll on the media hangers and then adjust the media guides.

You must use the correct media for the type of printing you require. When printing without a ribbon, you must use direct thermal media. When using ribbon, you must use thermal transfer media. The printer's ribbon sensor detects motion of the supply spindle.

Placing the Roll in the Media Compartment

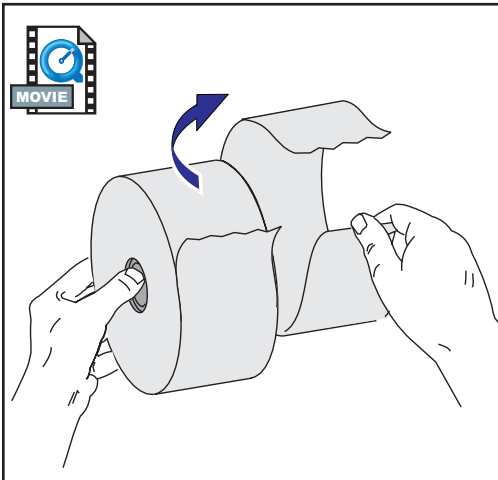

Whether your roll media is inside or outside wound you load it into the printer the same way.

1. Open the printer. Remember that you need to pull the release levers toward the front of the printer.
2. Remove the outside length of media. During shipment, the roll may become dirty when handled or dusty when stored. Removing the outside length avoids dragging adhesive or dirty media between the print head and platen.
3. Separate and hold open the media hangers.
4. Orient the media roll so that its printing surface will be up as it passes over the platen.
5. Lower the roll between the hangers and close them onto the core.

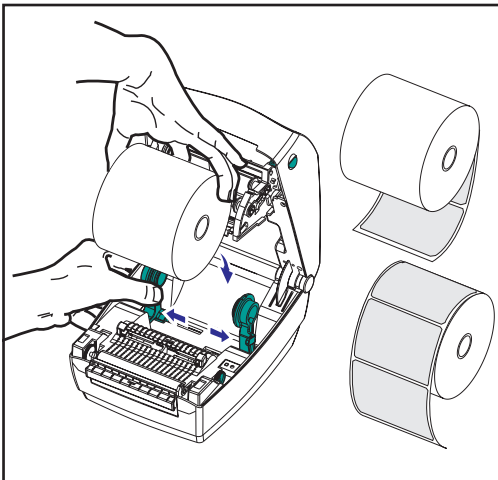

Adjusting the Guides

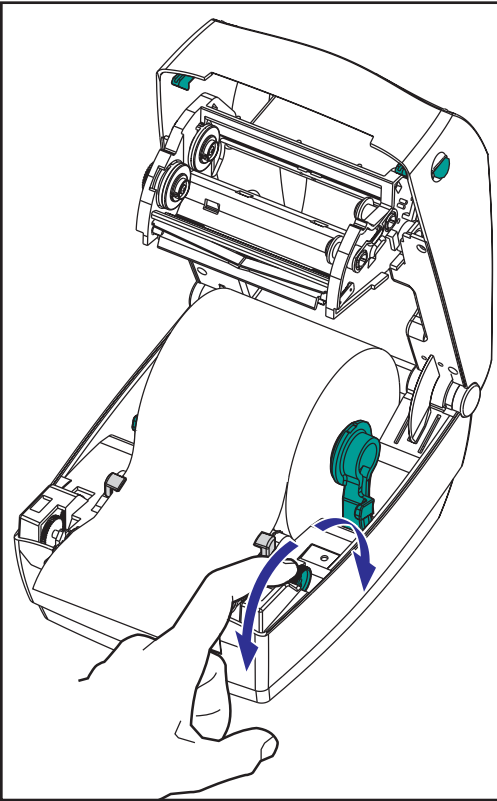

The adjustable guides direct the media toward the platen and print head.

1. Open the media guides by turning the guide adjuster knob to the rear.
2. Thread the media through the guides.
3. Close the media guides by turning the guide adjuster knob to the front. They should just touch, but not restrict, the edges of the media.
4. Unless you need to load ribbon, close the top cover. Remember that you need to release the cover lock, lower the top cover, and press down until the latches snap into place.

Using the Optional Media Adapter Plates

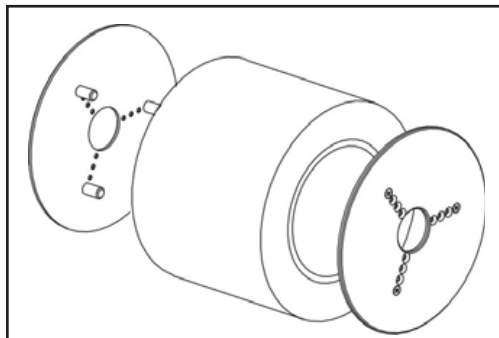
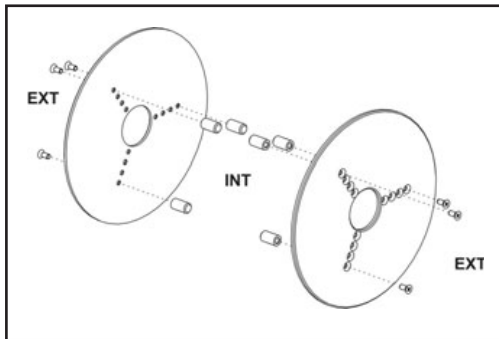
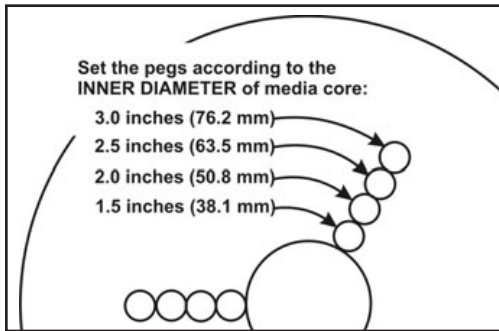

If your media roll has a larger diameter core, you can use an accessory to adapt the core to the media holders.

1. Note which position will fit the diameter of the roll core.
2. On the left side plate, align the pegs with the screws and use a small Phillips driver to tighten them.
3. On the right side plate, align the pegs with the screws and use a small Phillips driver to tighten them.
4. Align the plates so that the pegs hold the roll core and press together.
5. Place the roll into the media compartment.

Loading Ribbon



You must use thermal transfer media (accepts wax and/or resin transferred off a ribbon) when you use a ribbon. When loading ribbon, you install the supply and take-up rolls, then tighten the ribbon on the carriage.

Install the Ribbon Supply Roll

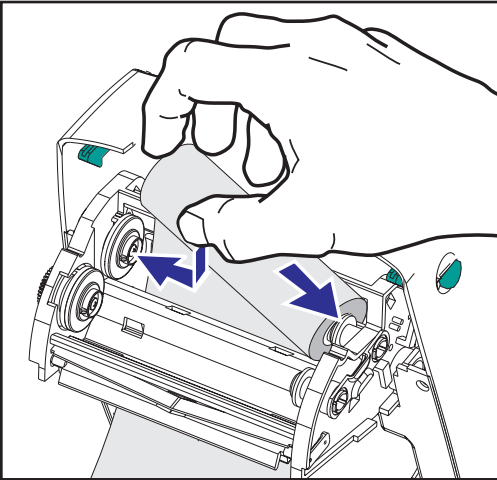

Before following these steps, prepare the ribbon by removing its wrapping and pulling its adhesive strip free.

1. Thread the ribbon through the carriage.
2. Press the right side onto the supply hub.
3. Align the notches on the left side and mount onto the spokes of the left hub.

Install the Take-Up Core

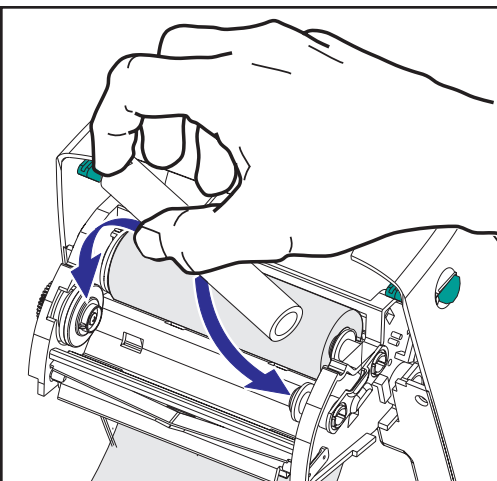

1. Press the right side onto the take-up hub.
2. Align the notches on the left side and mount onto the spokes of the left hub.

You can find your first ribbon take-up core in the packing box. Subsequently, use the empty supply core to take up the next roll of ribbon.

Attach and Tighten the Ribbon

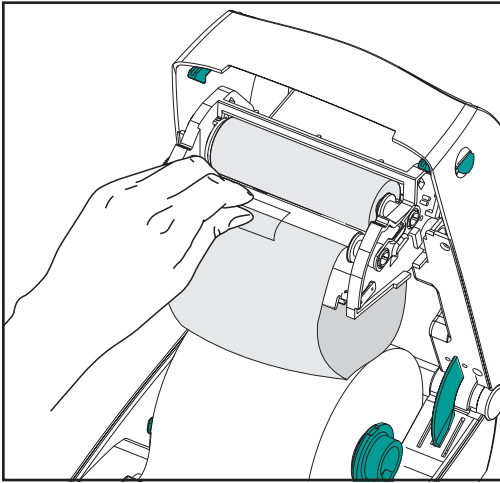

You must align the ribbon so that it will be taken straight onto the core.

1. Attach the ribbon to the take up core. Use the adhesive strip on new rolls; otherwise, use tape.

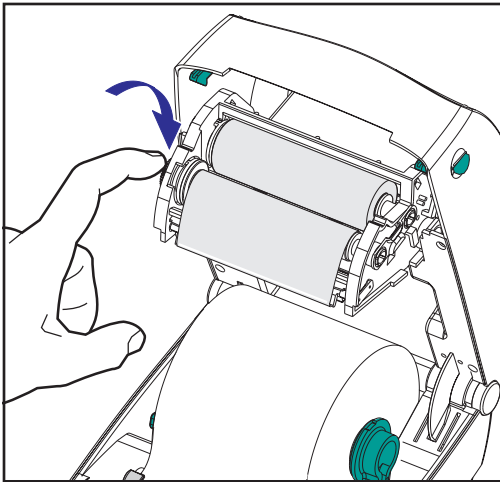

2. Turn the ribbon take-up gear counter-clockwise (top moves toward rear) to remove slack from the ribbon.
3. Close the top cover. Remember that you need to release the cover lock, lower the top cover, and press down until the latches snap into place.

Operator Controls

Power Switch

Press *up* to turn **ON** or *down* to turn **OFF** the printer.



CAUTION • The power should be turned off before connecting or disconnecting the communications and power cables.

Feed Button

Press once to feed one blank label.

Press once to take the printer out of a “pause” condition. (The printer is put into “pause” by either a programming command or an error condition.) See “What the Status Light is Telling You” on page 61.

Use the Feed button for printer setup and status (see “Feed Button Modes” on page 70).

Status Light

Functions as a printer operational indicator (see “What the Status Light is Telling You” on page 61).

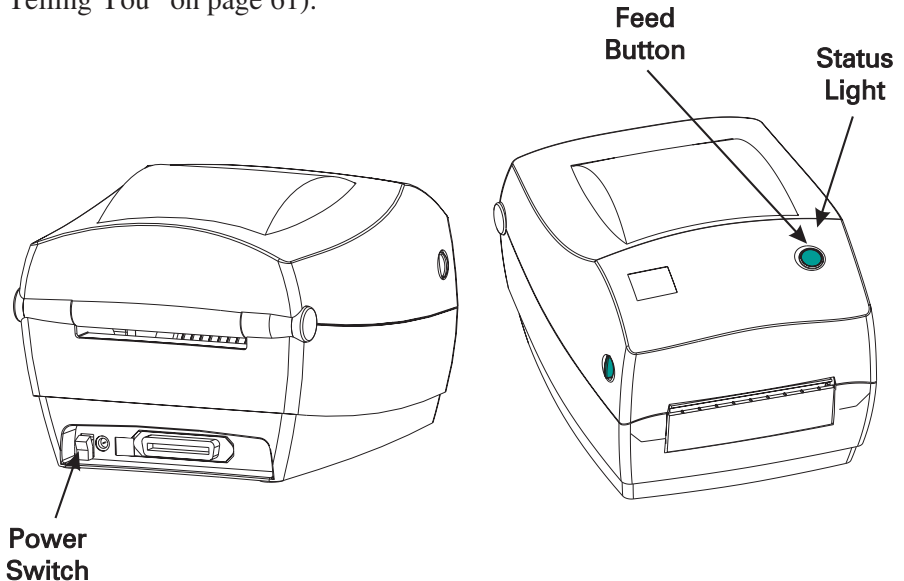

Printing a Test Label

PRINTER CONFIGURATION	
Zebra Technologies ZTC R2844-Z-200dpi	
+10.....	DARKNESS
+000.....	TEAR OFF
TEAR OFF.....	PRINT MODE
NON-CONTINUOUS.....	MEDIA TYPE
WEB.....	SENSOR TYPE
THERMAL-TRANS.....	PRINT METHOD
104 0/8 MM.....	PRINT WIDTH
1248.....	LABEL LENGTH
39.0IN 988MM.....	MAXIMUM LENGTH
NOT CONNECTED.....	USM COMM.
PARALLEL.....	PARALLEL COMM.
RS232.....	SERIAL COMM.
8600.....	BAUD
8 BITS.....	DATA BITS
NONE.....	PARITY
XON/XOFF.....	HOST HANDSHAKE
NONE.....	PROTOCOL
000.....	NETWORK ID
NORMAL MODE.....	COMMUNICATIONS
<~> 7EH.....	CONTROL PREFIX
<^> 5EH.....	FORMAT PREFIX
<,> 2CH.....	DELIMITER CHAR
ZPL II.....	ZPL MODE
FEED.....	MEDIA POWER UP
FEED.....	HEAD CLOSE
DEFAULT.....	BACKFEED
+020.....	LABEL TOP
+0000.....	LEFT POSITION
029.....	WEB S.
068.....	MEDIA S.
050.....	RIBBON S.
050.....	MARK S.
001.....	MARK MED S.
062.....	MEDIA LED
000.....	RIBBON LED
081.....	MARK LED
CS.....	MODES ENABLED
.....	MODES DISABLED
832 8/MM FULL.....	RESOLUTION
SP.814.B <-.....	FIRMWARE
V2.2.6.98.C.....	HARDWARE ID
CUSTOMIZED.....	CONFIGURATION
1024.....	R: RAM
0768.....	E: ONBOARD FLASH
NONE.....	FORMAT CONVERT
.....	TWINAX/COAX ID
NONE.....	OPTION
NONE.....	ZEBRA NET II
OEM400:Ver. 2.4F.....	RFID VERSION

FIRMWARE IN THIS PRINTER IS COPYRIGHTED

Before you connect the printer to your computer, make sure that the printer is in proper working order. You can do this by printing a configuration label.

1. Make sure the media is properly loaded and the top cover of the printer is closed. Then, turn the printer power on if you have not already done so.
2. When the status light is solid green, press and hold the feed button until the status light flashes once.
3. Release the feed button. A configuration label will print.

If you cannot get this label to print, refer to Troubleshooting on page 61.

Hooking Up the Printer and Computer

Your printer will have one of two combinations of interfaces:



- Universal Serial Bus (USB), parallel and serial
- USB, ethernet, and serial

Each specific interface option—USB, parallel, ethernet, serial—is discussed individually.

You must supply the required interface cable for your application.



CAUTIONS • Keep the power switch in the OFF position when attaching the interface cable.

The power supply barrel connector must be inserted into the power supply receptacle on the back of the printer before connecting or disconnecting the communications cables.

This printer complies with FCC “Rules and Regulations,” Part 15, for Class B Equipment, using fully shielded six-foot data cables. Use of longer cables or unshielded cables may increase radiated emissions above the Class B limits.

Interface Cable Requirements

Data cables must be of fully shielded construction and fitted with metal or metalized connector shells. Shielded cables and connectors are required to prevent radiation and reception of electrical noise.

To minimize electrical noise pickup in the cable:

Keep data cables as short as possible (6' [1.83 m] recommended).

Do not tightly bundle the data cables with power cords.

Do not tie the data cables to power wire conduits.

USB Interface Requirements

Universal Serial Bus (version 1.1) provides a high-speed interface that is compatible with your existing PC hardware. USB’s “plug and play” design makes installation easy. Multiple printers can share a single USB port/hub.

Parallel Interface Requirements

The required cable (IEEE 1284-compliant is recommended) must have a standard 36-pin parallel connector on one end, which is plugged into the parallel port located on the back of the printer. The other end of the parallel interface cable connects to the printer connector at the host computer.

For pinout information, refer to page 72.

Ethernet Interface Requirements

Ethernet provides a powerful networking capability that can be of use in a variety of internet/intranet printing solutions. After you load media and close the top cover, you can press the test button next to the connector on the rear of the printer to get an ethernet configuration label.

Serial Interface Requirements

The required cable must have a nine-pin “D” type (DB-9P) male connector on one end, which is plugged into the mating (DB-9S) serial port located on the back of the printer. The other end of this signal interface cable connects to a serial port at the host computer. Depending on the specific interface requirements, this will most likely be a null modem cable.

For pinout information, refer to page 74

Communicating with the Printer

Universal Serial Bus (USB) Communications

The printer is a terminal device when using a universal serial bus interface. You can refer to the Universal Serial Bus Specification for details regarding this interface.

Parallel Communications

When using the parallel port, typically there is no setup is required once the cable is plugged in. If you should encounter any problems, consult the user's guide that came with your computer.

Internal Ethernet Communications

For details regarding this interface, refer to the ethernet guide from the manufacturer.

Serial Communications

Serial communications between the printer and the host computer can be set by either autobaud synchronization or the **^SC** command.

Autobaud

Autobaud synchronization allows the printer to automatically match the communication parameters of the host computer. To autobaud:

1. Press and hold the feed button until the green status LED flashes once, twice, and then three times.
2. While the status LED flashes, send a ZPL II format to the printer.
3. When the printer and host are synchronized, the LED changes to solid green. (No labels will print during autobaud synchronization.)

^SC Command

Use the Set Communications (**^SC**) command to change the communications settings on the printer.

1. With the host computer set at the same communications settings as the printer, send the **^SC** command to change the printer to the desired settings.
2. Change the host computer settings to match the new printer settings.

Refer to the *ZPL II Programming Guide* for more information about this command.

Defaulting the Serial Parameters

To reset the communications parameters on the printer to the factory defaults (9600 baud, 8 bit word length, no parity, 1 stop bit, and XON/XOFF), do the following:

1. Press and hold the feed button until the green status LED flashes once, twice, and then three times.
2. While the status LED rapidly flashes amber and green, press the feed button.

Adjusting the Print Width

Print width must be calibrated when:

- You are using the printer for the first time.
- There is a change in the width of the media.

Print width may be set by way of the five-flash sequence in “Feed Button Modes” (see page 70) or refer to the Print Width (**^PW**) command (consult your *ZPL II Programming Guide*).

Adjusting the Print Quality

Print quality is influenced by the heat of the print head, the speed of the media and the type of media you are using. Only by experimenting will you find the optimal mix for your application.

The relative darkness setting is controlled by either the six-flash sequence in “Feed Button Modes” (see page 70) or the Set Darkness (**~SD**) ZPL II command (follow the instructions in the *ZPL II Programming Guide*).

If you find that the print speed needs to be adjusted, refer to the Print Rate (**^PR**) command in the *ZPL II Programming Guide*.