

**System > Settings > Screen Calibration**  
Touch each crosshair to calibrate the screen.

**DRAFT**

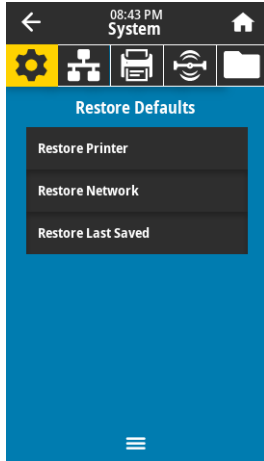

**System > Settings > Restore Defaults**

Restore specific printer, print server, and network settings back to the factory defaults. Use care when loading defaults because you will need to reload all settings that you changed manually. This menu item is available through two user menus with different default values for each.

|                                |  |
|--------------------------------|--|
| <i>Accepted values:</i>        | <p><b>PRINTER</b>—Restores all printer settings other than the network settings back to the factory defaults. Use care when loading defaults because you will need to reload all settings that you changed manually.</p> <p><b>NETWORK</b>—Reinitializes the printer’s wired or wireless print server. With a wireless print server, the printer also reassociates with your wireless network.</p> <p><b>LAST SAVED</b>—Loads settings from the last permanent save.</p> |
| <i>Related ZPL command(s):</i> | <p><b>PRINTER</b>—^JUF</p> <p><b>NETWORK</b>—^JUN</p> <p><b>LAST SAVED</b>—^JUR</p>  |
| <i>Control panel key(s):</i>   | <p><b>PRINTER</b>—Hold FEED + PAUSE during printer power-up to reset the printer parameters to factory values.</p> <p><b>NETWORK</b>—Hold CANCEL + PAUSE during printer power-up to reset the network parameters to factory values.</p> <p><b>LAST SAVED</b>: N/A</p>  |
| <i>Printer web page:</i>       | <p><b>PRINTER</b>—View and Modify Printer Settings &gt; Restore Default Configuration</p> <p><b>NETWORK</b>—Print Server Settings &gt; Reset Print Server</p> <p><b>LAST SAVED</b>—View and Modify Printer Settings &gt; Restore Saved Configuration</p>   |

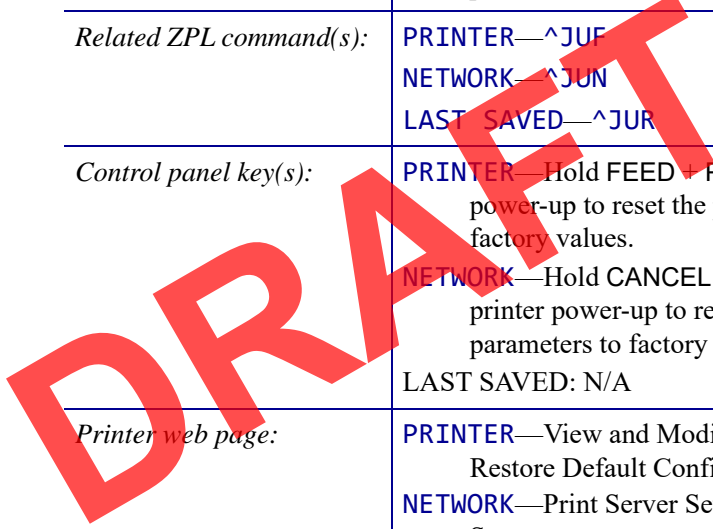

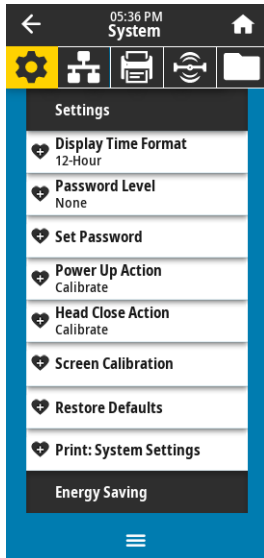

**System > Settings > Print: System Settings**

Prints a printer configuration label. The following is a sample label.

```

PRINTER CONFIGURATION
Zebra Technologies
ZTC ZT620R-203dpi ZPL
76J162700886

+30.0..... DARKNESS
6.0 IPS..... PRINT SPEED
-007..... TEAR OFF
TEAR OFF..... PRINT MODE
CONTINUOUS..... MEDIA TYPE
TRANSMISSIVE..... SENSOR SELECT
DIRECT-THERMAL..... PRINT METHOD
1344..... PRINT WIDTH
2000..... LABEL LENGTH
P1085892/00005 2..... PRINT HEAD ID
15.0IN 380MM..... MAXIMUM LENGTH
MAINT. OFF..... EARLY WARNING
CONNECTED..... USB COMM
BIDIRECTIONAL..... PARALLEL COMM.
RS232..... SERIAL COMM.
9600..... BAUD
8 BITS..... DATA BITS
NONE..... PARITY
XON/XOFF..... HOST HANDSHAKE
NONE..... PROTOCOL
NORMAL MODE..... COMMUNICATIONS
<-> 7EH..... CONTROL PREFIX
<-> 5EH..... FORMAT PREFIX
<-> 2CH..... DELIMITER CHAR
ZPL II..... ZPL MODE
INACTIVE..... COMMAND OVERRIDE
FEED..... MEDIA POWER UP
LENGTH..... HEAD CLOSE
DEFAULT..... BACKFEED
+000..... LABEL TOP
+0000..... LEFT POSITION
OFF..... APPLICATOR PORT
ENABLED..... ERROR ON PAUSE
PULSE MODE..... START PRINT SIG
DISABLED..... REPRINT MODE
080..... WEB SENSOR
090..... MEDIA SENSOR
255..... TAKE LABEL
027..... MARK SENSOR
027..... MARK MED SENSOR
000..... TRANS GAIN
005..... TRANS BASE
060..... TRANS LED
002..... MARK GAIN
100..... MARK LED
DPCSWFM..... MODES DISABLED
1344 8/MM FILL..... RESOLUTION
4.0..... LINK-OS VERSION
V80.20.03 <-..... FIRMWARE
G.6.0 22.89..... HARDWARE ID
32768k..... RAM
524288k..... ONBOARD FLASH
NONE..... FORMAT CONVERT
MM/DD/YYYY 24HR..... IDLE DISPLAY
05/11/17..... RTC DATE
08:40..... RTC TIME
ENABLED..... ZBI
2 1..... ZBI VERSION
READY..... ZBI STATUS
TIME MICRO..... RFID READER
20.00.00.01..... RFID HW VERSION
01.03.00.18..... RFID FW VERSION
USA/CANADA..... RFID REGION CODE
USA/CANADA..... RFID COUNTRY CODE
RFID OK..... RFID RTR STATUS
16..... RFID READ PWR
16..... RFID WRITE PWR
F0..... PROG. POSITION
0..... RFID VALID CTR
0..... RFID VOID CTR
NONE..... ADAPTIVE ANTENNA
A4..... RFID ANTENNA
570 LABELS..... NONRESET CNTR
570 LABELS..... RESET CNTR1
570 LABELS..... RESET CNTR2
2,798 IN..... NONRESET CNTR
2,798 IN..... RESET CNTR1
2,798 IN..... RESET CNTR2
7,107 CM..... NONRESET CNTR
7,107 CM..... RESET CNTR1
7,107 CM..... RESET CNTR2
001 WIRELESS..... SLOT 1
*** EMPTY..... SLOT 2
0..... MASS STORAGE COUNT
0..... HID COUNT
OFF..... USB HOST LOCK OUT
FIRMWARE IN THIS PRINTER IS COPYRIGHTED
    
```

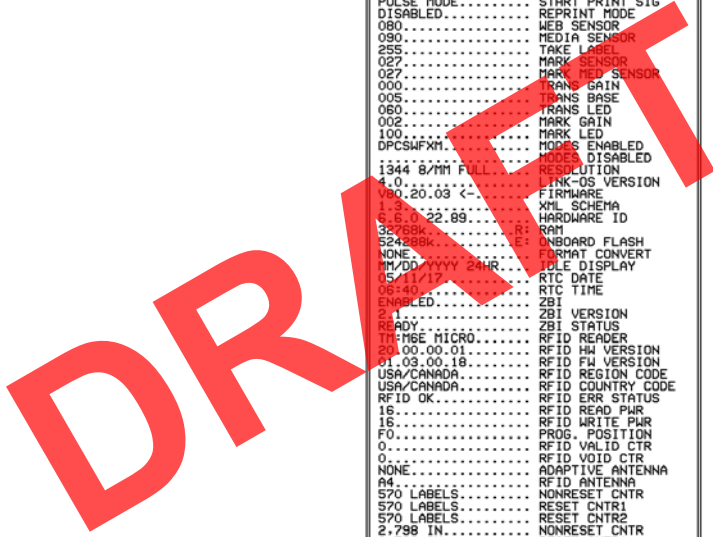

|                                |   |
|--------------------------------|---|
| <i>Related ZPL command(s):</i> | ~WC *   |
| <i>Control panel key(s):</i>   | Do one of the following:* <ul style="list-style-type: none"> <li>• Hold CANCEL during printer power-up. (Formerly called a CANCEL self test.</li> <li>• Hold FEED + CANCEL for 2 seconds when the printer is in the Ready state.</li> </ul> |
| <i>Printer web page:</i>       | View and Modify Printer Settings ><br>Print Listings on Label *   |

\* Prints a printer configuration label and a network configuration label.

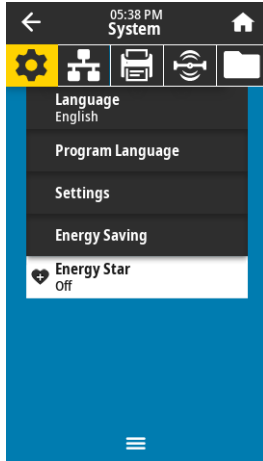

**System > Energy Saving > Energy Star**

When Energy Star mode is enabled, the printer goes into a “sleep” mode after a timeout period, thereby lowering power consumption. Press any button on the control panel to bring the printer back to an active state.

|                          |   |
|--------------------------|---|
| <i>Accepted values:</i>  | <ul style="list-style-type: none"> <li>• ON</li> <li>• OFF</li> </ul>   |
| <i>SGD command used:</i> | <p>power.energy_star.enable</p> <p>power.energy_star_timeout<br/>(to set the amount of idle time before Energy Star is invoked)</p> |

**Connection Menu**

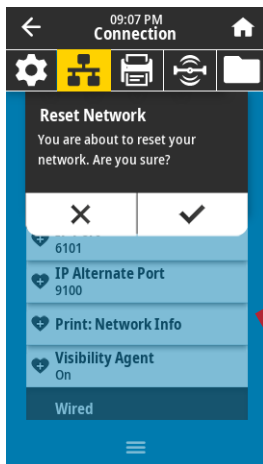

**Connection > Networks > Reset Network**

This option resets the wired or wireless print server and saves any changes that you made to any network settings.



**Important** • You must reset the print server to allow changes to the network settings to take effect.

|                                |  |
|--------------------------------|--|
| <i>Related ZPL command(s):</i> | ~WR  |
| <i>SGD command used:</i>       | device.reset                               |
| <i>Printer web page:</i>       | Print Server Settings > Reset Print Server |

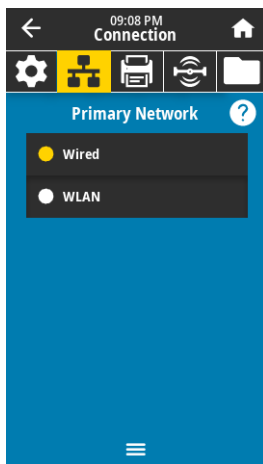

**Connection > Networks > Primary Network**

View or modify whether the wired or wireless print server is considered primary. You may select which one is primary.

|                                |   |
|--------------------------------|---|
| <i>Accepted values:</i>        | <ul style="list-style-type: none"> <li>• Wired</li> <li>• WLAN</li> </ul> |
| <i>Related ZPL command(s):</i> | ^NC   |
| <i>SGD command used:</i>       | ip.primary_network  |

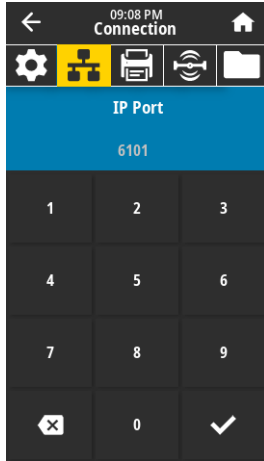

### Connection > Networks > IP Port

This printer setting refers to the internal wired print servers port number that the TCP print service is listening on. Normal TCP communications from the host should be directed to this port.

|                          |   |
|--------------------------|---|
| <i>SGD command used:</i> | <code>internal_wired.ip.port</code><br><code>wlan.ip.port</code>                        |
| <i>Printer web page:</i> | View and Modify Printer Settings ><br>Network Communications Setup ><br>TCP/IP Settings |

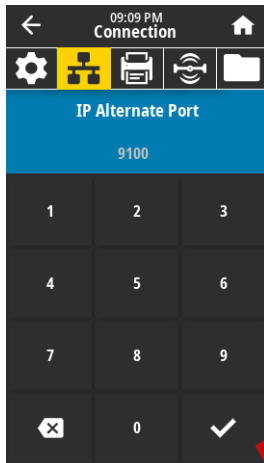

### Connection > Networks > IP Alternate Port

This command sets the port number of the alternate TCP port.



**Note** • Print servers supporting this command will monitor both the primary port and the alternate port for connections at the same time.

|                          |   |
|--------------------------|---|
| <i>SGD command used:</i> | <code>internal_wired.ip.port_alternate</code><br><code>wlan.ip.port_alternate</code>    |
| <i>Printer web page:</i> | View and Modify Printer Settings ><br>Network Communications Setup ><br>TCP/IP Settings |

DRAFT

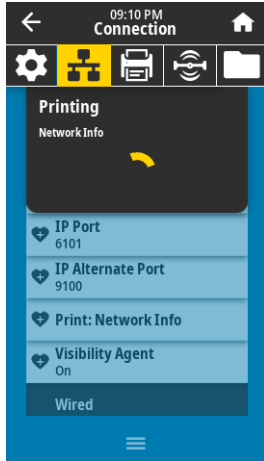

**Connection > Networks > Print: Network Info**

Prints the settings for any print server or Bluetooth device that is installed. The following is a sample label.

| Network Configuration                                       |                    |
|---|--------------------|
| Zebra Technologies<br>ZTC ZT620R-203dpi ZPL<br>76J162700886 |                    |
| Wired.....  | PRIMARY NETWORK    |
| PrintServer.....  | LOAD LAN FROM?     |
| INTERNAL WIRED.....   | ACTIVE PRINTSRVR   |
| <b>Wired*</b>   |                    |
| ALL.....  | IP PROTOCOL        |
| 192.168.000.017....   | IP ADDRESS         |
| 255.255.255.000....   | SUBNET             |
| 192.168.000.254....   | GATEWAY            |
| 000.000.000.000....   | WINS SERVER IP     |
| YES.....  | TIMEOUT CHECKING   |
| 300.....  | TIMEOUT VALUE      |
| 000.....  | ARP INTERVAL       |
| 9100.....   | BASE RAW PORT      |
| 9200.....   | JSON CONFIG PORT   |
| <b>Wireless</b>   |                    |
| ALL.....  | IP PROTOCOL        |
| 000.000.000.000....   | IP ADDRESS         |
| 255.255.255.000....   | SUBNET             |
| 000.000.000.000....   | GATEWAY            |
| 000.000.000.000....   | WINS SERVER IP     |
| YES.....  | TIMEOUT CHECKING   |
| 300.....  | TIMEOUT VALUE      |
| 000.....  | ARP INTERVAL       |
| 9100.....   | BASE RAW PORT      |
| 9200.....   | JSON CONFIG PORT   |
| INSERTED.....   | CARD INSERTED      |
| 02dfH.....  | CARD MFG ID        |
| 9134H.....  | CARD PRODUCT ID    |
| ac:3f:a4:82:05:9c..   | MAC ADDRESS        |
| YES.....  | DRIVER INSTALLED   |
| INFRASTRUCTURE.....   | OPERATING MODE     |
| 125.....  | ESSID              |
| 1.0.....  | CURRENT TX RATE    |
| OPEN.....   | WEP TYPE           |
| WPA PSK.....  | WLAN SECURITY      |
| 1.....  | WEP INDEX          |
| 000.....  | POOR SIGNAL        |
| LONG.....   | PREAMBLE           |
| NO.....   | ASSOCIATED         |
| ON.....   | PULSE ENABLED      |
| 15.....   | PULSE RATE         |
| OFF.....  | INTX MODE          |
| USA/CANADA.....   | REGION CODE        |
| USA/CANADA.....   | COUNTRY CODE       |
| 0x7FF.....  | CHANNEL MASK       |
| <b>Bluetooth</b>  |                    |
| 4.3.1b1.....  | FIRMWARE           |
| 02/13/2015.....   | DATE               |
| on.....   | DISCOVERABLE       |
| 3.0/4.0.....  | RADIO VERSION      |
| on.....   | ENABLED            |
| 0c:3f:a4:82:05:9d..   | MAC ADDRESS        |
| 76J162700886.....   | FRIENDLY NAME      |
| no.....   | CONNECTED          |
| 1.....  | MIN SECURITY MODE  |
| no.....   | CONN SECURITY MODE |
| supported.....  | IOS                |
| FIRMWARE IN THIS PRINTER IS COPYRIGHTED                     |                    |



|                                |   |
|--------------------------------|---|
| <i>Related ZPL command(s):</i> | ~WL   |
| <i>Control panel key(s):</i>   | Do one of the following:* <ul style="list-style-type: none"> <li>• Hold CANCEL during printer power-up. (Formerly called a CANCEL self test.</li> <li>• Hold FEED + CANCEL for 2 seconds when the printer is in the Ready state.</li> </ul> |
| <i>Printer web page:</i>       | View and Modify Printer Settings ><br>Print Listings on Label *   |

\* Prints a printer configuration label and a network configuration label.

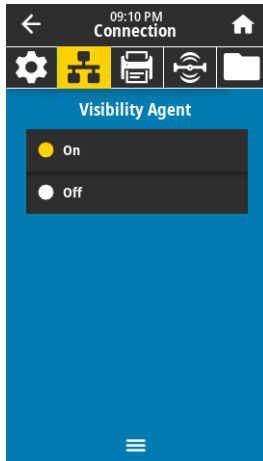

### Connection > Networks > Visibility Agent

When the printer is connected to a wired or wireless network, it will attempt to connect to Zebra’s Asset Visibility Service via the Cloud-based Zebra Printer Connector using an encrypted, certificate-authenticated web socket connection. The printer sends Discovery Data and Settings and Alerts Data. Data printed via any label formats is NOT transmitted.

To opt out of this feature, disable this setting. For more information, see the “Opting Out of the Asset Visibility Agent” application note at <http://www.zebra.com>.

|                          |   |
|--------------------------|---|
| <i>Accepted values:</i>  | <ul style="list-style-type: none"> <li>• ON</li> <li>• OFF</li> </ul>             |
| <i>SGD command used:</i> | <code>weblink.zebra_connector.enable</code>                                       |
| <i>Printer web page:</i> | View and Modify Printer Settings > Network Configuration > Cloud Connect Settings |

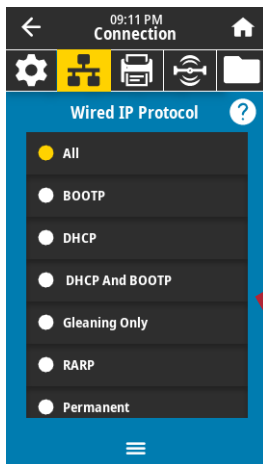

### Connection > Wired > Wired IP Protocol

This parameter indicates if the user (permanent) or the server (dynamic) selects the wired print server’s IP address. When a dynamic option is chosen, this parameter tells the method(s) by which this print server receives the IP address from the server.



**Important** • You must reset the print server to allow changes to the network settings to take effect. See [Connection > Networks > Reset Network](#) on page 64.

|                                |  |
|--------------------------------|--|
| <i>Accepted values:</i>        | <ul style="list-style-type: none"> <li>• ALL</li> <li>• GLEANING ONLY</li> <li>• RARP</li> <li>• BOOTP</li> <li>• DHCP</li> <li>• DHCP &amp; BOOTP</li> <li>• PERMANENT</li> </ul> |
| <i>Related ZPL command(s):</i> | <code>^ND</code>   |
| <i>SGD command used:</i>       | <code>internal_wired.ip.protocol</code>  |
| <i>Printer web page:</i>       | View and Modify Printer Settings > Network Communications Setup > TCP/IP Settings  |

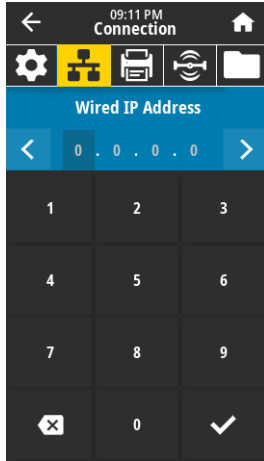

**Connection > Wired > Wired IP Address**

View and, if necessary, change the printer's wired IP address.

To save changes to this setting, set *Connection > Wired > Wired IP Protocol* on page 67 to PERMANENT, and then reset the print server (see *Connection > Networks > Reset Network* on page 64).

|                                |   |
|--------------------------------|---|
| <i>Accepted values:</i>        | 000 to 255 for each field   |
| <i>Related ZPL command(s):</i> | ^ND   |
| <i>SGD command used:</i>       | internal_wired.ip.addr  |
| <i>Printer web page:</i>       | View and Modify Printer Settings ><br>Network Communications Setup ><br>TCP/IP Settings |

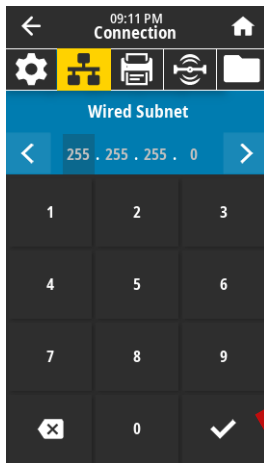

**Connection > Wired > Wired Subnet**

View and, if necessary, change the wired subnet mask.

To save changes to this setting, set *Connection > Wired > Wired IP Protocol* on page 67 to PERMANENT, and then reset the print server (see *Connection > Networks > Reset Network* on page 64).

|                                |   |
|--------------------------------|---|
| <i>Accepted values:</i>        | 000 to 255 for each field   |
| <i>Related ZPL command(s):</i> | ^ND   |
| <i>SGD command used:</i>       | internal_wired.ip.netmask   |
| <i>Printer web page:</i>       | View and Modify Printer Settings ><br>Network Communications Setup ><br>TCP/IP Settings |

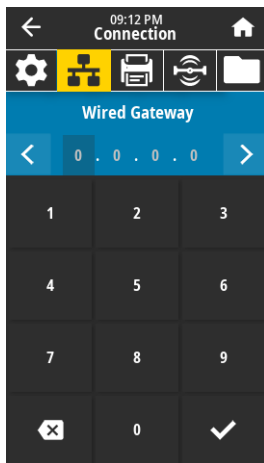

**Connection > Wired > Wired Gateway**

View and, if necessary, change the default wired gateway.

To save changes to this setting, set *Connection > Wired > Wired IP Protocol* on page 67 to PERMANENT, and then reset the print server (see *Connection > Networks > Reset Network* on page 64).

|                                |   |
|--------------------------------|---|
| <i>Accepted values:</i>        | 000 to 255 for each field   |
| <i>Related ZPL command(s):</i> | ^ND   |
| <i>SGD command used:</i>       | internal_wired.ip.gateway   |
| <i>Printer web page:</i>       | View and Modify Printer Settings ><br>Network Communications Setup ><br>TCP/IP Settings |



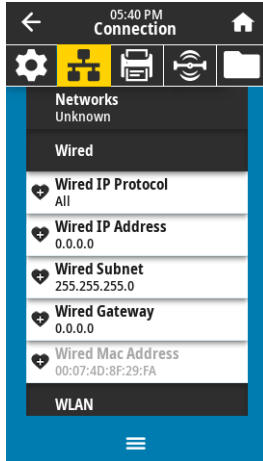

**Connection > Wired > Wired Mac Address**

View the Media Access Control (MAC) address of the wired print server. This value cannot be modified.

|                          |   |
|--------------------------|---|
| <i>SGD command used:</i> | <code>internal_wired.mac_addr</code>  |
| <i>Printer web page:</i> | View and Modify Printer Settings ><br>Network Communications Setup ><br>TCP/IP Settings |

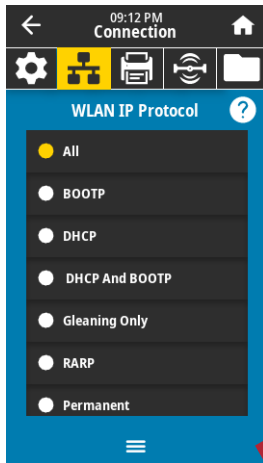

**Connection > WLAN > WLAN IP Protocol**

This parameter indicates if the user (permanent) or the server (dynamic) selects the wireless print server's IP address. When a dynamic option is chosen, this parameter tells the method(s) by which this print server receives the IP address from the server.



**Important** • You must reset the print server to allow changes to the network settings to take effect. See [Connection > Networks > Reset Network](#) on page 64.

|                                |  |
|--------------------------------|--|
| <i>Accepted values:</i>        | <ul style="list-style-type: none"> <li>• ALL</li> <li>• GLEANING ONLY</li> <li>• RARP</li> <li>• BOOTP</li> <li>• DHCP</li> <li>• DHCP &amp; BOOTP</li> <li>• PERMANENT</li> </ul> |
| <i>Related ZPL command(s):</i> | <code>^ND</code>   |
| <i>SGD command used:</i>       | <code>wlan.ip.protocol</code>  |
| <i>Printer web page:</i>       | View and Modify Printer Settings ><br>Network Communications Setup ><br>Wireless Setup   |



**Connection > WLAN > WLAN IP Address**

View and, if necessary, change the printer's wireless IP address.

To save changes to this setting, set *Connection > WLAN > WLAN IP Protocol* on page 69 to PERMANENT, and then reset the print server (see *Connection > Networks > Reset Network* on page 64).

|                                |  |
|--------------------------------|--|
| <i>Accepted values:</i>        | 000 to 255 for each field  |
| <i>Related ZPL command(s):</i> | ^ND  |
| <i>SGD command used:</i>       | ip.addr, wlan.ip.addr  |
| <i>Printer web page:</i>       | View and Modify Printer Settings ><br>Network Communications Setup ><br>Wireless Setup |

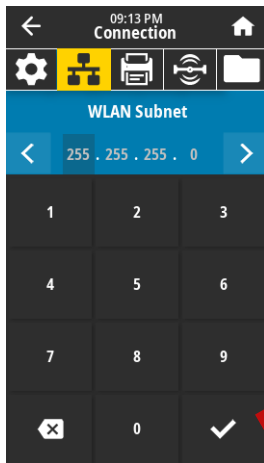

**Connection > WLAN > WLAN Subnet**

View and, if necessary, change the wireless subnet mask.

To save changes to this setting, set *Connection > WLAN > WLAN IP Protocol* on page 69 to PERMANENT, and then reset the print server (see *Connection > Networks > Reset Network* on page 64).

|                                |  |
|--------------------------------|--|
| <i>Accepted values:</i>        | 000 to 255 for each field  |
| <i>Related ZPL command(s):</i> | ^ND  |
| <i>SGD command used:</i>       | wlan.ip.netmask  |
| <i>Printer web page:</i>       | View and Modify Printer Settings ><br>Network Communications Setup ><br>Wireless Setup |

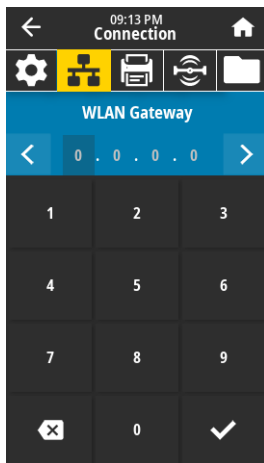

**Connection > WLAN > WLAN Gateway**

View and, if necessary, change the default wireless gateway.

To save changes to this setting, set *Connection > WLAN > WLAN IP Protocol* on page 69 to PERMANENT, and then reset the print server (see *Connection > Networks > Reset Network* on page 64).

|                                |  |
|--------------------------------|--|
| <i>Accepted values:</i>        | 000 to 255 for each field  |
| <i>Related ZPL command(s):</i> | ^ND  |
| <i>SGD command used:</i>       | wlan.ip.gateway  |
| <i>Printer web page:</i>       | View and Modify Printer Settings ><br>Network Communications Setup ><br>Wireless Setup |



**Connection > WLAN > WLAN Mac Address**

View the Media Access Control (MAC) address of the wireless print server. This value cannot be modified.

|                          |  |
|--------------------------|--|
| <i>SGD command used:</i> | <code>wlan.mac_addr</code>   |
| <i>Printer web page:</i> | View and Modify Printer Settings ><br>Network Communications Setup ><br>Wireless Setup |

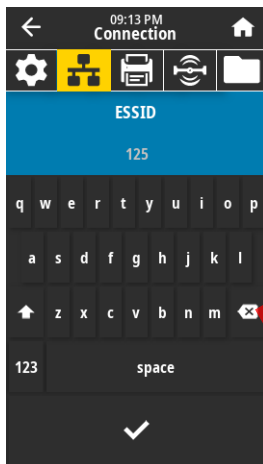

**Connection > WLAN > ESSID**

The Extended Service Set Identification (ESSID) is an identifier for your wireless network. This setting, which cannot be modified from the control panel, gives the ESSID for the current wireless configuration.

|                          |  |
|--------------------------|--|
| <i>Accepted values:</i>  | 32-character alphanumeric string (default 125)   |
| <i>SGD command used:</i> | <code>wlan.essid</code>  |
| <i>Printer web page:</i> | View and Modify Printer Settings ><br>Network Communications Setup ><br>Wireless Setup |

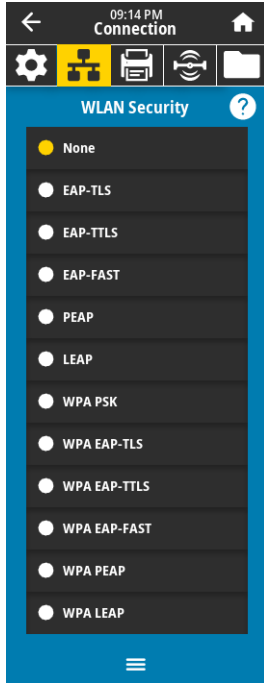

**Connection > WLAN > WLAN Security**

Select the security type being used on your WLAN.

|                                |   |
|--------------------------------|---|
| <i>Related ZPL command(s):</i> | ^WX   |
| <i>SGD command used:</i>       | wlan.security   |
| <i>Printer web page:</i>       | View and Modify Printer Settings ><br>Network Communications Setup ><br>Wireless Encryption Setup |

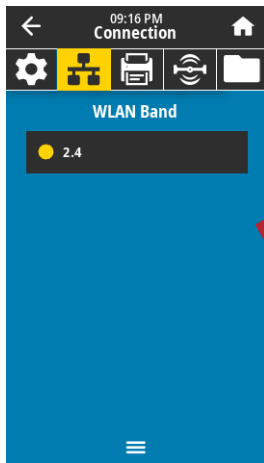

**Connection > WLAN > WLAN Band**  
???

|                          |  |
|--------------------------|--|
| <i>Accepted values:</i>  | ???  |
| <i>SGD command used:</i> | ???  |
| <i>Printer web page:</i> | View and Modify Printer Settings ><br>Network Communications Setup ><br>Wireless Setup |

DRAFT

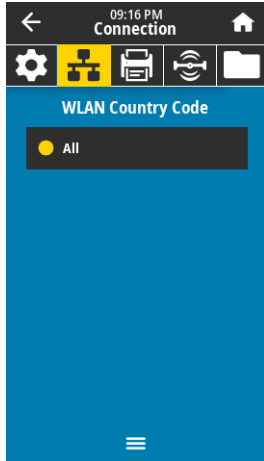

**Connection > WLAN > WLAN Country Code**

The country code defines the regulatory country for which the wireless radio is currently configured.



**Important** • The list of country codes is specific to each printer and depends on the printer model and its wireless radio configuration. The list is subject to change, addition, or deletion with any firmware update, at any time, without notice.

To determine the country codes available on your printer, issue the `! U1 getvar "wlan"` command to return all commands related to WLAN settings. Locate the `wlan.country.code` command in the results and view the country codes available for your printer.

|                          |                                |
|--------------------------|--------------------------------|
| <i>SGD command used:</i> | <code>wlan.country_code</code> |
|--------------------------|--------------------------------|

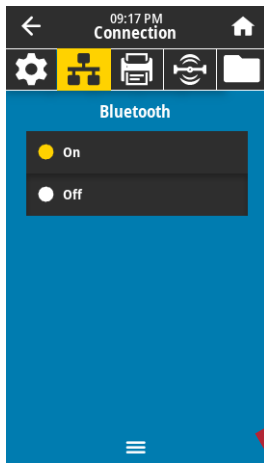

**Connection > Bluetooth > Bluetooth**

Select if the printer is “Discoverable” for Bluetooth device pairing.

|                         |  |
|-------------------------|--|
| <i>Accepted values:</i> | <ul style="list-style-type: none"> <li>• <b>ON</b>—Enables the Bluetooth radio.</li> <li>• <b>OFF</b>—Disables the Bluetooth radio.</li> </ul> |
|-------------------------|--|

|                          |                               |
|--------------------------|-------------------------------|
| <i>SGD command used:</i> | <code>bluetooth.enable</code> |
|--------------------------|-------------------------------|

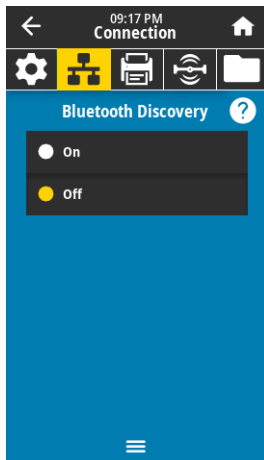

**Connection > Bluetooth > Bluetooth Discovery**

Select if the printer is “Discoverable” for Bluetooth device pairing.

|                         |  |
|-------------------------|--|
| <i>Accepted values:</i> | <ul style="list-style-type: none"> <li>• <b>ON</b>—Enables Bluetooth discoverable mode.</li> <li>• <b>OFF</b>—Disables Bluetooth discoverable mode.</li> </ul> |
|-------------------------|--|

|                          |                                     |
|--------------------------|-------------------------------------|
| <i>SGD command used:</i> | <code>bluetooth.discoverable</code> |
|--------------------------|-------------------------------------|

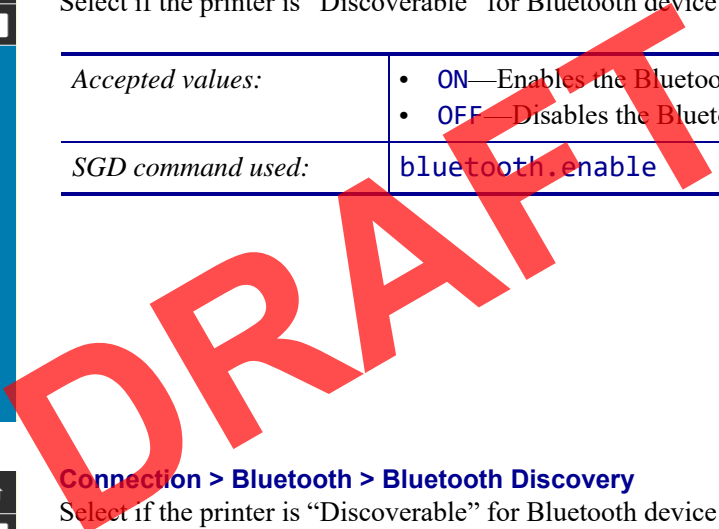

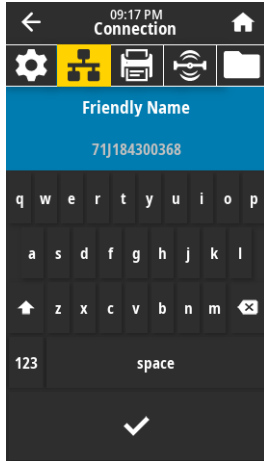

### Connection > Bluetooth > Friendly Name

This command sets the friendly name, which is used during service discovery. For changes to take effect, you must power cycle the printer or issue the `device.reset` command (see [Connection > Networks > Reset Network](#) on page 64).

If you do not set a friendly name, it will default to the printer serial number.

|                          |                                      |
|--------------------------|--------------------------------------|
| <i>Accepted values:</i>  | 17-character text string             |
| <i>SGD command used:</i> | <code>bluetooth.friendly_name</code> |

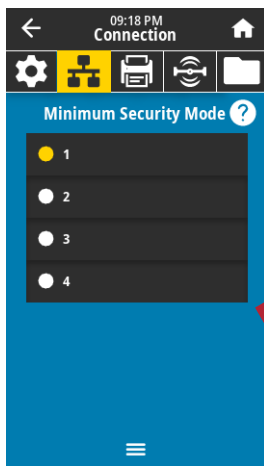

### Connection > Bluetooth > Minimum Security Mode

This printer setting parameter sets the Bluetooth Minimum Security mode. Minimum Security Mode provides for different levels of security, depending on the printer radio version and printer firmware. See the *Zebra Programming Guide* at <http://www.zebra.com/manuals> for more information.

|                          |  |
|--------------------------|--|
| <i>Accepted values:</i>  | 1, 2, 3, 4                                   |
| <i>SGD command used:</i> | <code>bluetooth.minimum_security_mode</code> |

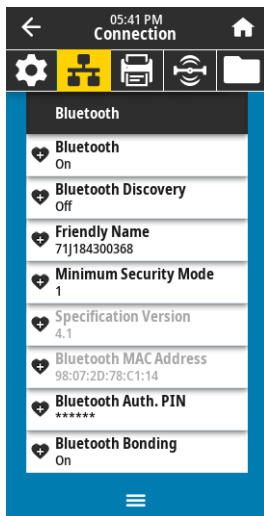

### Connection > Bluetooth > Specification Version

This parameter displays the Bluetooth library version number.

|                          |                                |
|--------------------------|--------------------------------|
| <i>SGD command used:</i> | <code>bluetooth.version</code> |
|--------------------------|--------------------------------|

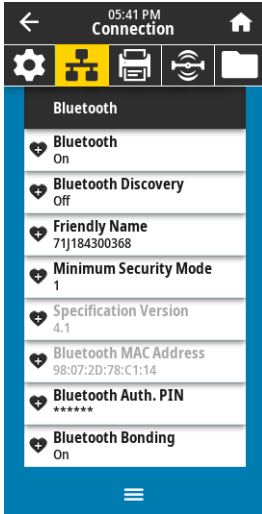

**Connection > Bluetooth > MAC Address**

This parameter displays the Bluetooth device address.

|                          |                   |
|--------------------------|-------------------|
| <i>SGD command used:</i> | bluetooth.address |
|--------------------------|-------------------|

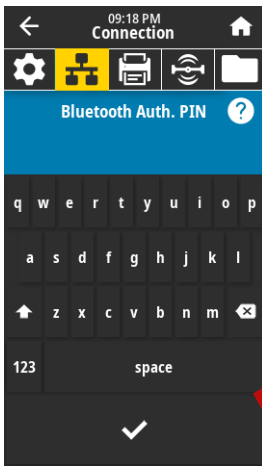

**Connection > Bluetooth > Bluetooth Auth. PIN**

Set the PIN used when Bluetooth authentication is enabled.

|                          |   |
|--------------------------|---|
| <i>SGD command used:</i> | bluetooth.bluetooth_pin (to set the PIN)<br>bluetooth.authentication (to enable authentication) |
|--------------------------|---|

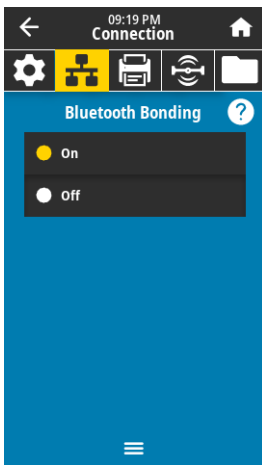

**Connection > Bluetooth > Bluetooth Bonding**

???

|                          |  |
|--------------------------|--|
| <i>Accepted values:</i>  | <ul style="list-style-type: none"> <li>• ON—Enables Bluetooth bonding.</li> <li>• OFF—Disables Bluetooth bonding.</li> </ul> |
| <i>SGD command used:</i> | bluetooth.???  |

DRAFT

## Print Menu

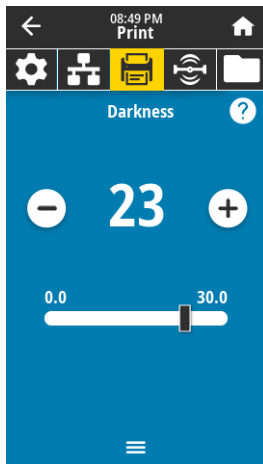

### Print > Print Quality > Darkness

Set the print darkness to the lowest setting that provides good print quality. If you set the darkness too high, the label image may print unclearly, barcodes may not scan correctly, the ribbon may burn through, or the printhead may wear prematurely.

|                                |   |
|--------------------------------|---|
| <i>Accepted values:</i>        | 0.0 to 30.0   |
| <i>Related ZPL command(s):</i> | ^MD, ~SD  |
| <i>SGD command used:</i>       | print.tone  |
| <i>Printer web page:</i>       | View and Modify Printer Settings > General Setup > Darkness |

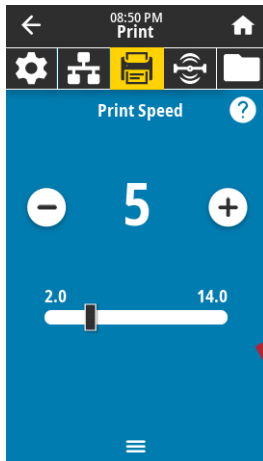

### Print > Print Quality > Print Speed

Select the speed, in inches per second (ips), for printing a label. Slower print speeds typically yield better print quality.

|                                |   |
|--------------------------------|---|
| <i>Accepted values:</i>        | ZT610 203 dpi = 2 to 14 ips<br>ZT610 300 dpi = 2 to 12 ips<br>ZT610 600 dpi = 1 to 6 ips<br>ZT620 203 dpi = 2 to 12 ips<br>ZT620 300 dpi = 2 to 8 ips |
| <i>Related ZPL command(s):</i> | ^PR   |
| <i>SGD command used:</i>       | media.speed   |
| <i>Printer web page:</i>       | View and Modify Printer Settings > General Setup > Print Speed  |

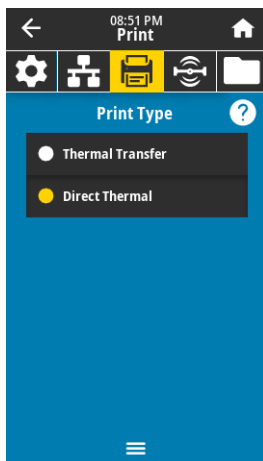

### Print > Print Quality > Print Type

Specify if the printer needs to use ribbon for printing.

|                                |  |
|--------------------------------|--|
| <i>Accepted values:</i>        | <ul style="list-style-type: none"> <li><b>THERMAL TRANS</b>—Uses ribbon and thermal transfer media.</li> <li><b>DIRECT THERMAL</b>—Uses direct thermal media and no ribbon.</li> </ul> |
| <i>Related ZPL command(s):</i> | ^MT  |
| <i>SGD command used:</i>       | ezpl.print_method  |
| <i>Printer web page:</i>       | View and Modify Printer Settings > Media Setup > Print Method  |



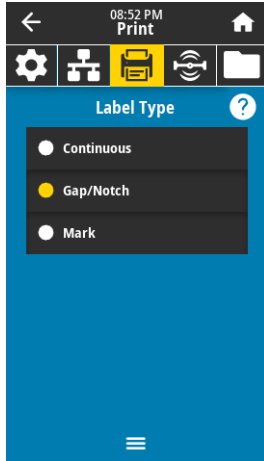

**Print > Print Quality > Label Type**

Select the type of media that you are using.

|                                |  |
|--------------------------------|--|
| <i>Accepted values:</i>        | <ul style="list-style-type: none"> <li>CONTINUOUS</li> <li>GAP/NOTCH</li> <li>MARK</li> </ul> <p>If you select <b>CONTINUOUS</b>, you must include a label length in your label format (^LL if you are using ZPL). If you select <b>GAP/NOTCH</b> or <b>MARK</b> for various noncontinuous media, the printer feeds media to calculate the label length.</p> |
| <i>Related ZPL command(s):</i> | ^MN  |
| <i>SGD command used:</i>       | ezpl.media_type  |
| <i>Printer web page:</i>       | View and Modify Printer Settings > Media Setup > Media Type  |

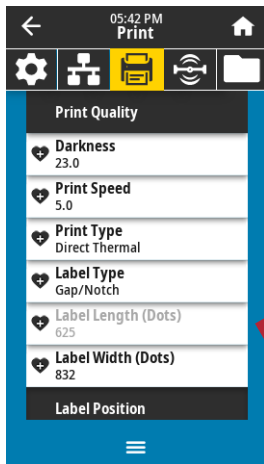

**Print > Print Quality > Label Length**

View the calibrated label length in dots. This value cannot be modified.

DRAFT

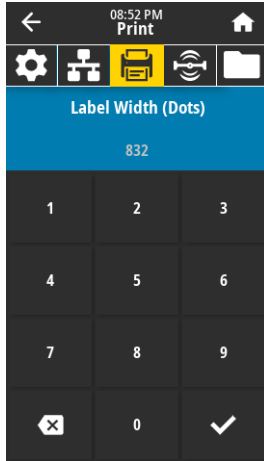

**Print > Print Quality > Label Width (Dots)**

Specify the width of the labels being used, in dots. The default value is the maximum width for the printer, based on the printhead's DPI value.

|                                |  |
|--------------------------------|--|
| <i>Accepted values:</i>        |  <p><b>Note</b> • Setting the width too narrow can result in portions of a label format not being printed on the media. Setting the width too wide wastes formatting memory and can cause the printer to print off of the label and onto the platen roller. This setting can affect the horizontal position of the label format if the image was inverted using the ^POI ZPL II command.</p> <p>ZT610 203 dpi = 0002 to 832<br/>                 ZT610 300 dpi = 0002 to 1248<br/>                 ZT610 600 dpi = 0002 to 2496<br/>                 ZT620 203 dpi = 0002 to 1344<br/>                 ZT620 300 dpi = 0002 to 1984</p> |
| <i>Related ZPL command(s):</i> | ^PW  |
| <i>SGD command used:</i>       | ezpl.print_width   |
| <i>Printer web page:</i>       | View and Modify Printer Settings > Media Setup > Print Width   |

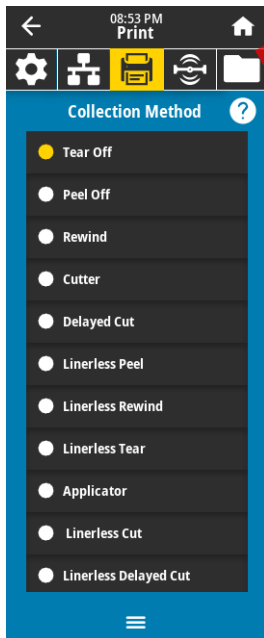

**Print > Label Position > Collection Method**

Select a collection method that is compatible with the options available on your printer.

|                                |   |
|--------------------------------|---|
| <i>Accepted values:</i>        | <ul style="list-style-type: none"> <li>• Tear Off</li> <li>• Peel-off</li> <li>• Rewind</li> <li>• Cutter</li> <li>• Delayed Cut</li> <li>• Linerless Peel</li> <li>• Linerless Rewind</li> <li>• Linerless Tear</li> <li>• Applicator</li> <li>• Linerless Cut</li> <li>• Linerless Delayed Cut</li> </ul> |
| <i>Related ZPL command(s):</i> | ^MM   |
| <i>SGD command used:</i>       | media.printmode   |
| <i>Printer web page:</i>       | View and Modify Printer Settings > General Setup > Print Mode   |

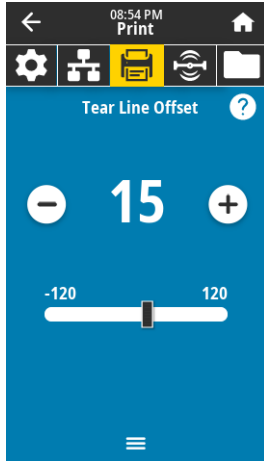

**Print > Label Position > Tear Line Offset**

If necessary, shift the position of the media over the tear-off bar after printing.

- Lower numbers move the media into the printer by the specified number of dots (the tear line moves closer to the edge of the label just printed).
- Higher numbers move the media out of the printer (the tear line moves closer to the leading edge of the next label).

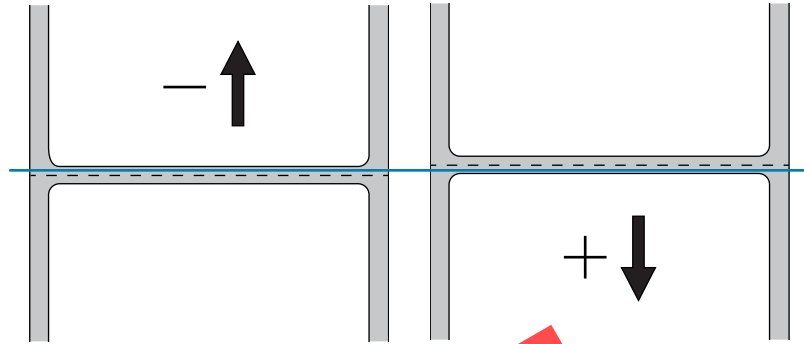

|                                |  |
|--------------------------------|--|
| <i>Accepted values:</i>        | -120 to +120   |
| <i>Related ZPL command(s):</i> | ~TA  |
| <i>SGD command used:</i>       | ezpl.tear_off  |
| <i>Printer web page:</i>       | View and Modify Printer Settings > General Setup<br>> Tear Off |

DRAFT

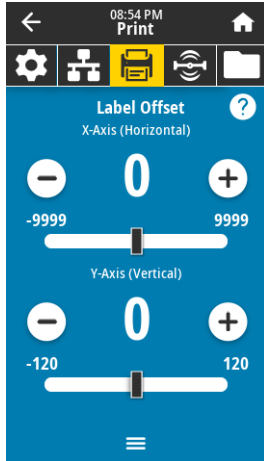

**Print > Label Position > Label Offset**

If necessary, shift the position of the image horizontally or vertically on the label.

**Horizontal**

- Negative numbers move the left edge of the image toward the left edge of the label by the number of dots selected.
- Positive numbers move the edge of the image toward the right edge of the label.

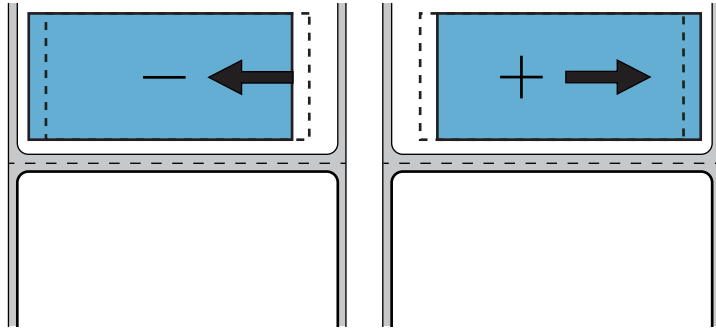

|                                |  |
|--------------------------------|--|
| <i>Accepted values:</i>        | -9999 to 9999  |
| <i>Related ZPL command(s):</i> | ^LS  |
| <i>SGD command used:</i>       | zpl.left_position  |
| <i>Printer web page:</i>       | View and Modify Printer Settings ><br>Advanced Setup > Left Position |

**Vertical**

- Lower numbers move the image higher on the label (toward the printhead).
- Higher numbers move the image farther down on the label (away from the printhead) by the specified number of dots.

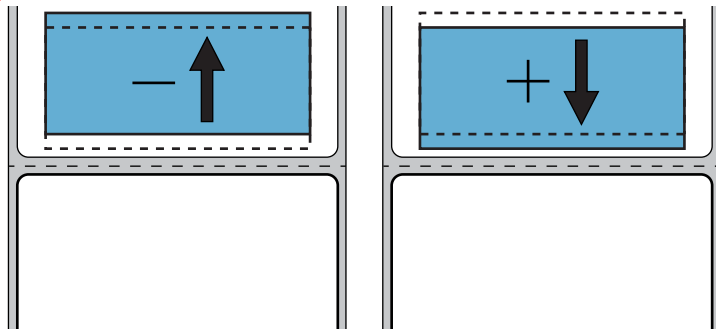

|                                |   |
|--------------------------------|---|
| <i>Accepted values:</i>        | -120 to +120  |
| <i>Related ZPL command(s):</i> | ^LT   |
| <i>Printer web page:</i>       | View and Modify Printer Settings > General Setup<br>> Label Top |

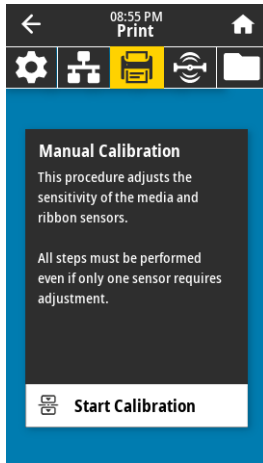

### Print > Sensors > Manual Calibration

Calibrate the printer to adjust the sensitivity of the media and ribbon sensors.

|                                |   |
|--------------------------------|---|
| <i>Related ZPL command(s):</i> | ~JC   |
| <i>SGD command used:</i>       | ezpl.manual_calibration   |
| <i>Control panel key(s):</i>   | Hold PAUSE + FEED + CANCEL for 2 seconds to initiate calibration.   |
| <i>Printer web page:</i>       | The calibration procedure cannot be initiated through the web pages. See the following web page for settings that are set during sensor calibration:<br><br>View and Modify Printer Settings > Calibration<br><br> <b>Important</b> • Do not change these settings unless you are told to do so by Zebra Technical Support or by an authorized service technician. |

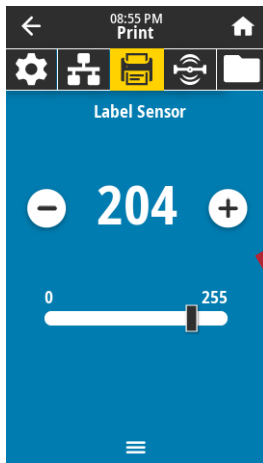

### Print > Sensors > Label Sensor

Set the sensitivity of the label sensor.

 **Important** • This value is set during sensor calibration. Do not change these settings unless you are told to do so by Zebra Technical Support or by an authorized service technician.

|                          |  |
|--------------------------|--|
| <i>Accepted values:</i>  | 0 to 255                                       |
| <i>SGD command used:</i> | ezpl.label_sensor                              |
| <i>Printer web page:</i> | View and Modify Printer Settings > Calibration |

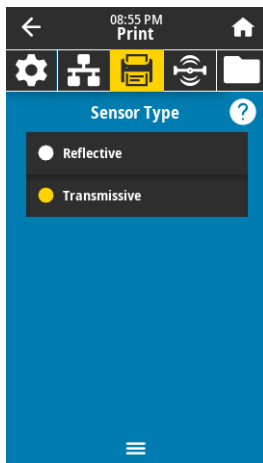

### Print > Sensors > Sensor Type

Select the media sensor that is appropriate for the media that you are using. The reflective sensor typically is used only for black mark media. The transmissive sensor typically is used for other media types.

|                                |  |
|--------------------------------|--|
| <i>Accepted values:</i>        | <ul style="list-style-type: none"> <li>TRANSMISSIVE</li> <li>REFLECTIVE</li> </ul> |
| <i>Related ZPL command(s):</i> | ^JS  |
| <i>SGD command used:</i>       | device.sensor_select   |
| <i>Printer web page:</i>       | View and Modify Printer Settings > Media Setup                                     |

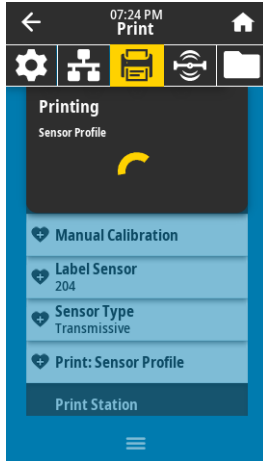

**Print > Sensors > Print: Sensor Profile**

Shows the sensor settings compared to actual sensor readings. To interpret the results, see *Sensor Profile on page 122*.

|                                |  |
|--------------------------------|--|
| <i>Accepted values:</i>        | <ul style="list-style-type: none"> <li>• TRANSMISSIVE</li> <li>• REFLECTIVE</li> </ul> |
| <i>Related ZPL command(s):</i> | ~JG  |
| <i>Control panel key(s):</i>   | Hold FEED + CANCEL during printer power-up.  |
| <i>Printer web page:</i>       | View and Modify Printer Settings ><br>Print Listings on Label                          |

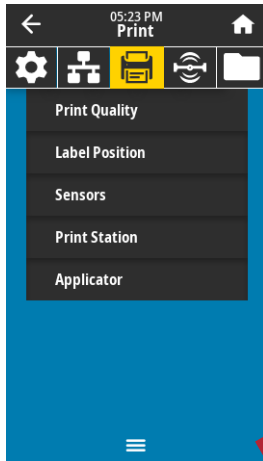

**Print > Print Station**

Use this menu item to fill in variable fields in a label format and print the label using a Human Input Device (HID), such as a USB keyboard, scale, or barcode scanner. A suitable label format must be stored on the E: drive of the printer to use this option.

When you plug an HID into one of the printer's USB host ports, use this user menu to select a form on the printer's E: drive. After you have been prompted to fill in each variable ^FN field on the form, you can specify the desired quantity of labels to print.

For more information about using the ^FN command or the SGD commands related to this feature, see the *Zebra Programming Guide* at <http://www.zebra.com/manuals> for more information.

\* This menu item can be used only if a USB Flash drive with a suitable label format is inserted into a USB host port on the printer.

|                          |   |
|--------------------------|---|
| <i>SGD command used:</i> | <pre>usb.host.keyboard_input (must be set to ON) usb.host.template_list usb.host.fn_field_list usb.host.fn_field_data usb.host.fn_last_field usb.host.template_print_amount</pre> |
|--------------------------|---|

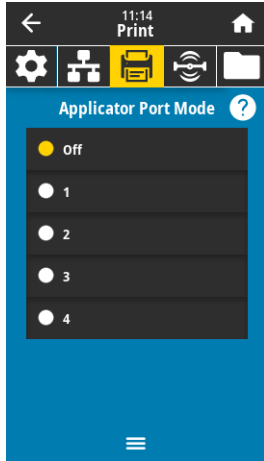

**Print > Applicator > Applicator Port Mode**

Controls the way in which the applicator port’s “End Print” signal functions.

|                                |  |
|--------------------------------|--|
| <i>Accepted values:</i>        | <p>Off</p> <p>1 = End Print signal normally high, and low only when the printer is moving the label forward.</p> <p>2 = End Print signal normally low, and high only when the printer is moving the label forward.</p> <p>3 = End Print signal normally high, and low for 20 ms when a label has been printed and positioned.</p> <p>4 = End Print signal normally low, and high for 20 ms when a label has been printed and positioned.</p> |
| <i>Related ZPL command(s):</i> | ^JJ  |
| <i>SGD command used:</i>       | device.applicator.end_print  |

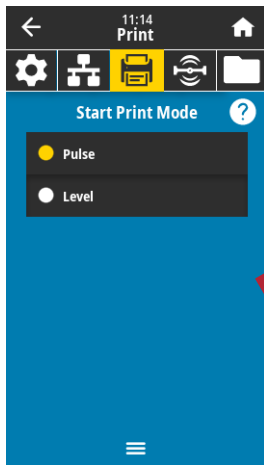

**Print > Applicator > Start Print Mode**

Determines if the applicator port’s “Start Print” signal is in level mode or pulse mode.

|                                |  |
|--------------------------------|--|
| <i>Accepted values:</i>        | <ul style="list-style-type: none"> <li><b>Pulse</b>—Start Print signal must be deasserted before it can be asserted for the next label.</li> <li><b>Level</b>—Start Print signal does not need to be deasserted to print the next label. As long as the Start Print signal is low and a label is formatted, a label prints.</li> </ul> |
| <i>Related ZPL command(s):</i> | ^JJ  |
| <i>SGD command used:</i>       | device.applicator.start_print  |

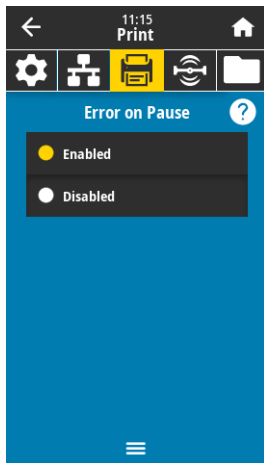

**Print > Applicator > Error on Pause**

Determines how applicator port errors are treated by the printer. Enabling this feature also causes the “Service Required” pin to be asserted.

|                          |   |
|--------------------------|---|
| <i>Accepted values:</i>  | <ul style="list-style-type: none"> <li><b>ENABLED</b></li> <li><b>DISABLED</b></li> </ul> |
| <i>SGD command used:</i> | device.applicator.error_on_pause  |
| <i>Printer web page:</i> | View and Modify Printer Settings > Advanced Setup > Error on Pause                        |

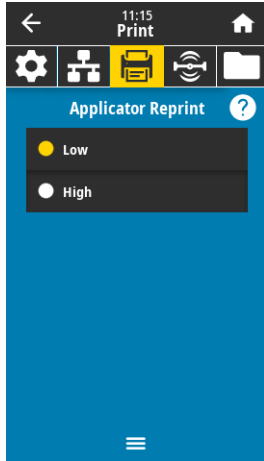

**Print > Applicator > Applicator Reprint**

Specifies if a high or low value is required for an applicator to reprint a label.

Enables or disables the ~PR command, which when enabled reprints the last printed label. It also enables the Reprint button on the Home screen.

|                                |                           |
|--------------------------------|---------------------------|
| <i>Related ZPL command(s):</i> | ^JJ and ~PR               |
| <i>SGD command used:</i>       | device.applicator.reprint |

**RFID Menu**

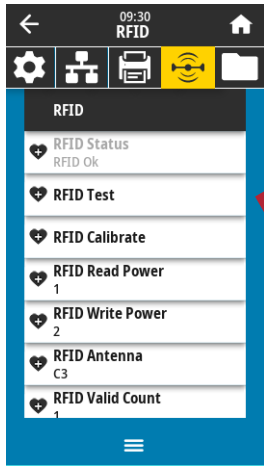

**RFID > RFID Status**

Display the status of the RFID subsystem of the printer.

|                                |                     |
|--------------------------------|---------------------|
| <i>Related ZPL command(s):</i> | ^HL or ~HL          |
| <i>SGD command used:</i>       | rfid.error.response |

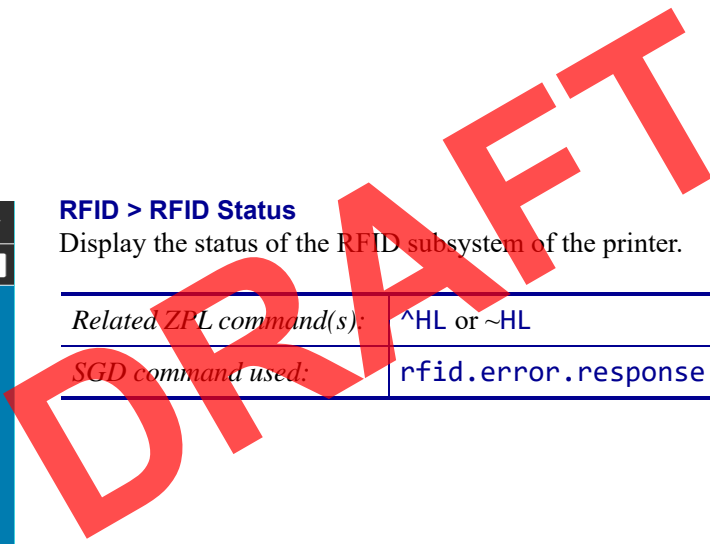



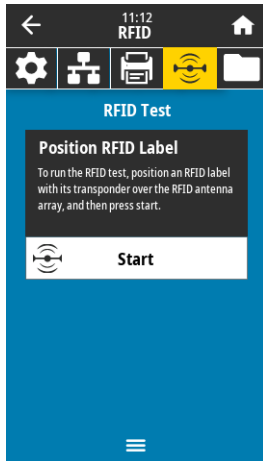

### RFID > RFID Test

During the RFID test, the printer attempts to read and write to a transponder. No printer movement occurs with this test.

#### To test an RFID label:

1. Position the RFID label with its transponder over the RFID antenna array.
2. Touch **Start**.

The results of the test are shown on the display.

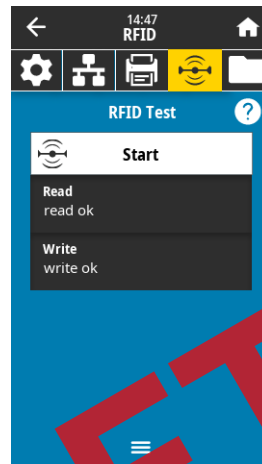

---

|                          |  |
|--------------------------|--|
| <i>SGD command used:</i> | <code>rfid.tag.test.content</code> and<br><code>rfid.tag.test.execute</code> |
|--------------------------|--|

---

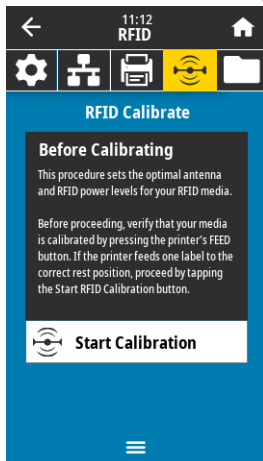

### RFID > RFID Calibrate

Initiate tag calibration for RFID media. (Not the same as media and ribbon calibration.) During the process, the printer moves the media, calibrates the RFID tag position, and determines the optimal settings for the RFID media being used. These settings include the programming position, the antenna element to use, and the read/write power level to use. See the *RFID Programming Guide 3* for more information.



**Important** • Before running this command, load the printer with RFID media, calibrate your printer, close the printhead, and feed at least one label to make sure that tag calibration will begin from the correct position.

Leave all transponders before and after the tag that is being calibrated. This allows the printer to determine RFID settings which do not encode the adjacent tag. Allow a portion of media to extend out the front of the printer to allow for backfeed during the tag calibration procedure.

---

|                                |                                 |
|--------------------------------|---------------------------------|
| <i>Related ZPL command(s):</i> | <code>^HR</code>                |
| <i>SGD command used:</i>       | <code>rfid.tag.calibrate</code> |

---

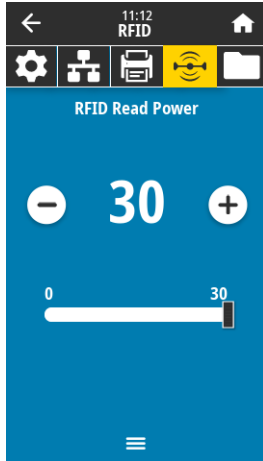

**RFID > Read Power**

If the desired read power is not achieved through RFID tag calibration, a value may be specified.

|                                |   |
|--------------------------------|---|
| <i>Accepted values:</i>        | 0 to 30   |
| <i>Related ZPL command(s):</i> | ^RW   |
| <i>SGD command used:</i>       | rfid.reader_1.power.read                                      |
| <i>Printer web page:</i>       | View and Modify Printer Settings > RFID Setup > RFID READ PWR |

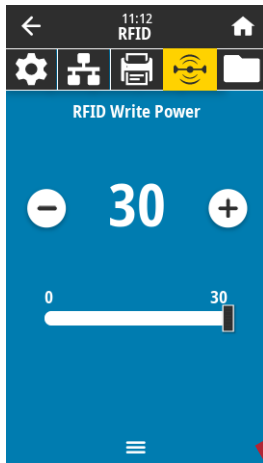

**RFID > Write Power**

If the desired write power is not achieved through RFID tag calibration, a value may be specified.

|                                |  |
|--------------------------------|--|
| <i>Accepted values:</i>        | 0 to 30  |
| <i>Related ZPL command(s):</i> | ^RW  |
| <i>SGD command used:</i>       | rfid.reader_1.power.write                                      |
| <i>Printer web page:</i>       | View and Modify Printer Settings > RFID Setup > RFID WRITE PWR |

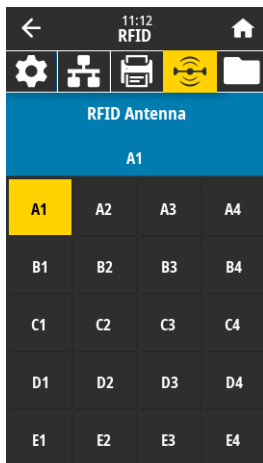

**RFID > RFID Antenna**

If the desired antenna is not achieved through RFID tag calibration, a value may be specified.

|                                |  |
|--------------------------------|--|
| <i>Accepted values:</i>        | A1, A2, A3, A4<br>B1, B2, B3, B4<br>C1, C2, C3, C4<br>D1, D2, D3, D4<br>E1, E2, E3, E4 |
| <i>Related ZPL command(s):</i> | ^RW  |
| <i>SGD command used:</i>       | rfid.reader_1.antenna_port   |
| <i>Printer web page:</i>       | View and Modify Printer Settings > RFID Setup > RFID ANTENNA                           |

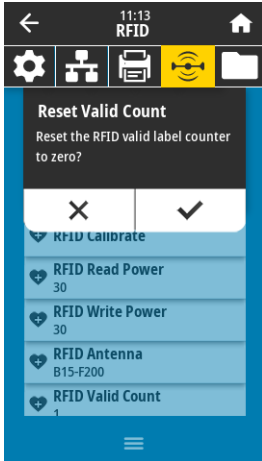

**RFID > RFID Valid Count**

Resets the RFID valid label counter to zero.

|                                |                               |
|--------------------------------|-------------------------------|
| <i>Related ZPL command(s):</i> | ~RO                           |
| <i>SGD command used:</i>       | odometer.rfid.valid_resetable |

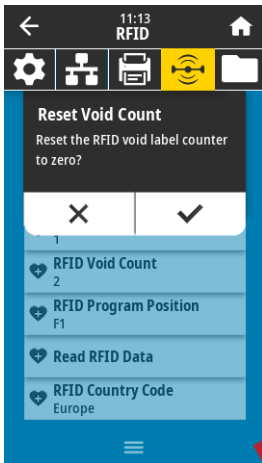

**RFID > RFID Void Count**

Resets the RFID void label counter to zero.

|                                |                              |
|--------------------------------|------------------------------|
| <i>Related ZPL command(s):</i> | ~RO                          |
| <i>SGD command used:</i>       | odometer.rfid.void_resetable |

DRAFT

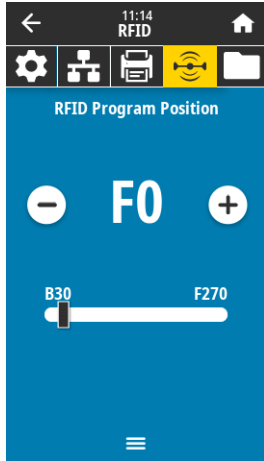

**RFID > RFID Program Position**

If the desired programming position (read/write position) is not achieved through RFID tag calibration, a value may be specified.

|                                |  |
|--------------------------------|--|
| <i>Accepted values:</i>        | <p><b>F0</b> to <b>Fxxx</b> (where <b>xxx</b> is the label length in millimeters or <b>999</b>, whichever is less)—The printer feeds the label forward for the specified distance and then begins programming.</p> <p><b>B0</b> to <b>B30</b>—The printer backfeeds the label for the specified distance and then begins programming. To account for the backfeed, allow empty media liner to extend out of the front of the printer when using a backward programming position.</p> |
| <i>Related ZPL command(s):</i> | <code>^RS</code>   |
| <i>SGD command used:</i>       | <code>rfid.position.program</code>   |
| <i>Printer web page:</i>       | View and Modify Printer Settings > RFID Setup > PROGRAM POSITION   |

DRAFT

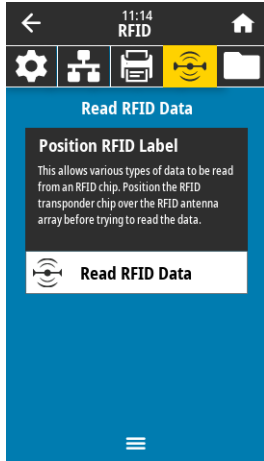

**RFID > Read RFID Data**

Read and return the specified tag data from the RFID tag located over the RFID antenna. No printer movement occurs while tag data is being read. The printhead can be open or closed.

**To read and display the information stored on an RFID tag:**

1. Position the RFID label with its transponder over the RFID antenna.
2. Touch **Read RFID Data**.

The results of the test are shown on the display.

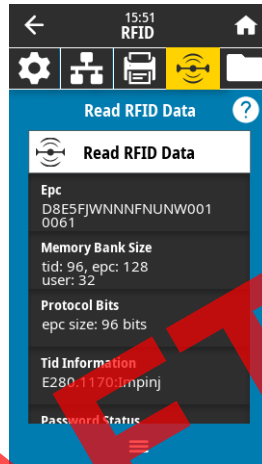

|                                |  |
|--------------------------------|--|
| <i>Related ZPL command(s):</i> | ^RF  |
| <i>SGD command used:</i>       | rfid.tag.read.content<br>rfid.tag.read.execute |

## Storage Menu

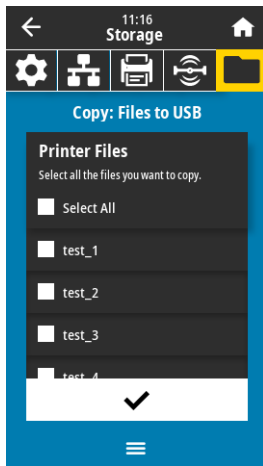

### Storage > USB > Copy: Files to USB

Select files from the printer to store on a USB Flash drive.

#### To copy files from the printer to a USB Flash drive:

1. Insert a USB flash drive into the printer's USB host port.  
The printer lists available files.
2. Touch the box next to the desired files. **Select All** is also available.
3. Touch the check mark to copy the selected files.

|                          |                                  |
|--------------------------|----------------------------------|
| <i>SGD command used:</i> | <code>usb.host.write_list</code> |
|--------------------------|----------------------------------|

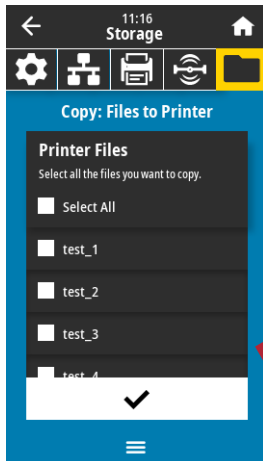

### Storage > USB > Copy: Files to Printer

Select files to copy to the printer from a USB Flash drive.

#### To copy files to the printer from a USB Flash drive:

1. Insert a USB flash drive into the printer's USB host port.  
The printer lists available files.
2. Touch the box next to the desired files. **Select All** is also available.
3. Touch the check mark to copy the selected files.

|                          |                                 |
|--------------------------|---------------------------------|
| <i>SGD command used:</i> | <code>usb.host.read_list</code> |
|--------------------------|---------------------------------|

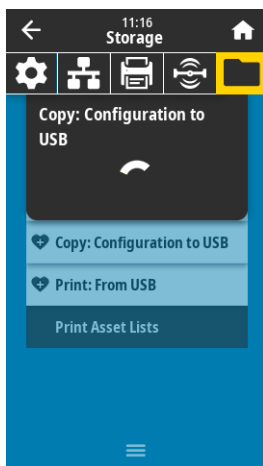

### Storage > USB > Copy: Configuration to USB

Use this function to copy the printer's configuration information to a USB mass storage device, such as a USB Flash drive, that is plugged into one of the printer's USB host ports. This makes the information accessible without having to print physical labels.

|                                |  |
|--------------------------------|--|
| <i>Related ZPL command(s):</i> | <code>^HH</code> —Returns the printer configuration information returned to the host computer. |
|--------------------------------|--|

|                          |   |
|--------------------------|---|
| <i>Printer web page:</i> | Printer Home Page > View Printer Configuration<br>(to view printer configuration information on your web browser)<br>View and Modify Printer Settings > Print Listings on Label<br>(to print the configuration information on labels) |
|--------------------------|---|

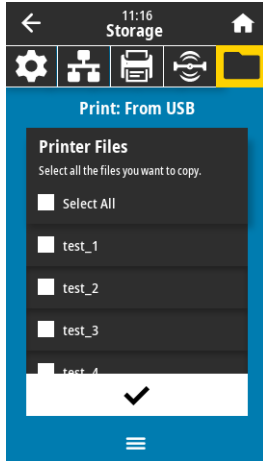

**Storage > USB > Print: From USB**

Select files to print from a USB Flash drive.

**To print files from a USB Flash drive:**

1. Insert a USB flash drive into the printer’s USB host port.  
The printer lists available files.
2. Touch the box next to the desired files. **Select All** is also available.
3. Touch the check mark to print the selected files.

|                          |                                 |
|--------------------------|---------------------------------|
| <i>SGD command used:</i> | <code>usb.host.read_list</code> |
|--------------------------|---------------------------------|

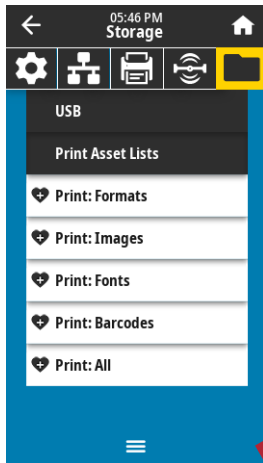

**Storage > Print Asset Lists**

Print the specified information on one or more labels.

|                         |  |
|-------------------------|--|
| <i>Accepted values:</i> | <ul style="list-style-type: none"> <li>• <b>FORMATS</b>—Prints the available formats stored in the printer’s RAM, Flash memory, or optional memory card.</li> <li>• <b>IMAGES</b>—Prints the available images stored in the printer’s RAM, Flash memory, or optional memory card.</li> <li>• <b>FONTS</b>—Prints the available fonts in the printer, including standard printer fonts plus any optional fonts. Fonts may be stored in RAM or Flash memory.</li> <li>• <b>BARCODES</b>—Prints the available barcodes in the printer. Barcodes may be stored in RAM or Flash memory.</li> <li>• <b>ALL</b>—Prints the previous labels plus the printer configuration label and the network configuration label.</li> </ul> |
|-------------------------|--|

|                                |                  |
|--------------------------------|------------------|
| <i>Related ZPL command(s):</i> | <code>^WD</code> |
|--------------------------------|------------------|

|                          |   |
|--------------------------|---|
| <i>Printer web page:</i> | View and Modify Printer Settings ><br>Print Listings on Label |
|--------------------------|---|

## Calibrate the Ribbon and Media Sensors

Use the procedure in this section to calibrate the printer, which adjusts the sensitivity of the media and ribbon sensors.

To perform sensor calibration, complete these steps:

1. Touch **Print** > **Sensors** > **Manual Calibration**.

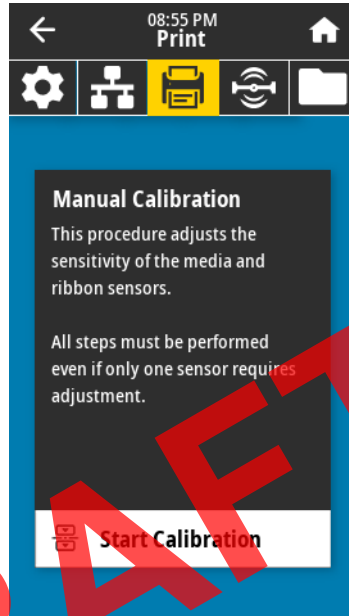

2. Touch **Start Calibration**.
3. Follow the steps in the calibration procedure.



**Important** • Follow the calibration procedure exactly as presented. You may press and hold **CANCEL** at any step in the procedure to cancel the calibration process.

4. When calibration is complete, press **PAUSE** to exit pause mode and enable printing.



## Adjust the Printhead Pressure

You may need to adjust printhead pressure if printing is too light on one side, if you use thick media, or if the media drifts from side to side during printing. Use the lowest printhead pressure necessary to produce good print quality.

See [Figure 2](#). The printhead pressure adjustment dials have setting marks from 1 to 4.

**Figure 2 • Printhead Pressure Adjustment Dials**

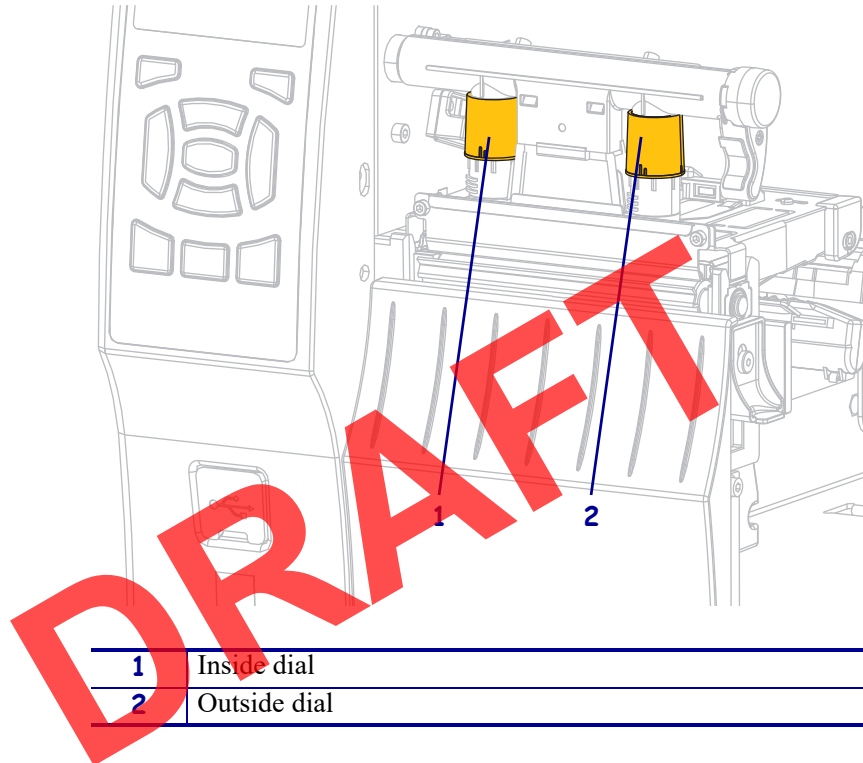

See [Table 3](#). Begin with the following pressure settings, based on your printer and media width, and make adjustments as necessary.

**Table 3 • Pressure Setting Starting Points**

| Printer      | Media Width       | Inside Dial Setting | Outside Dial Setting |
|--------------|-------------------|---------------------|----------------------|
| <b>ZT411</b> | 1 in. (25 mm)     | 4                   | 1                    |
|              | 2 in. (51 mm)     | 3                   | 1                    |
|              | 3 in. (76 mm)     | 2.5                 | 1.5                  |
|              | ≥ 3.5 in. (89 mm) | 2                   | 2                    |
| <b>ZT421</b> | 2 in. (51 mm)     | 4                   | 1                    |
|              | 3 in. (76 mm)     | 3.5                 | 1                    |
|              | 4 in. (102 mm)    | 3                   | 2                    |
|              | ≥ 5 in. (127 mm)  | 2.5                 | 2.5                  |

If necessary, adjust the printhead pressure adjustment dials as follows:

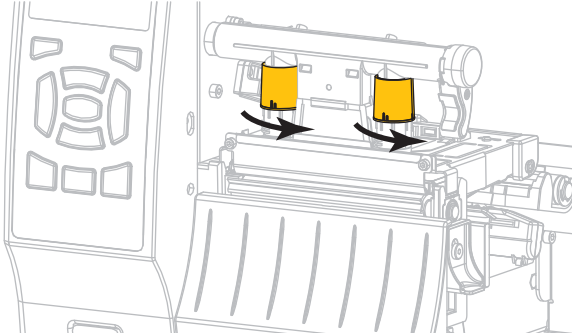
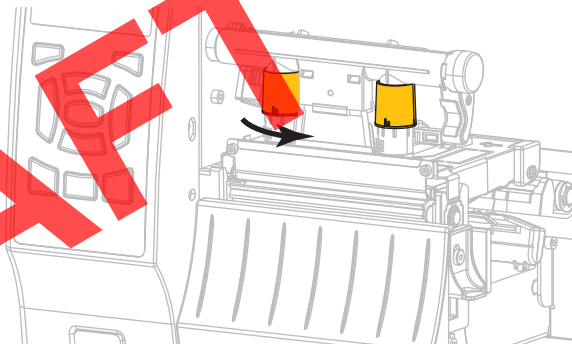
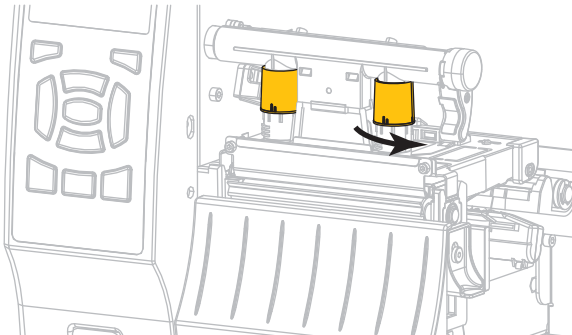
| If the media...                                    | Then...   |
|--|---|
| Requires higher pressure to print well             | Increase both dials one position.<br>                 |
| Prints too lightly on the left side of the label.  | Increase the inside dial setting one position.<br>   |
| Prints too lightly on the right side of the label. | Increase the outside dial setting one position.<br> |

DRAFT

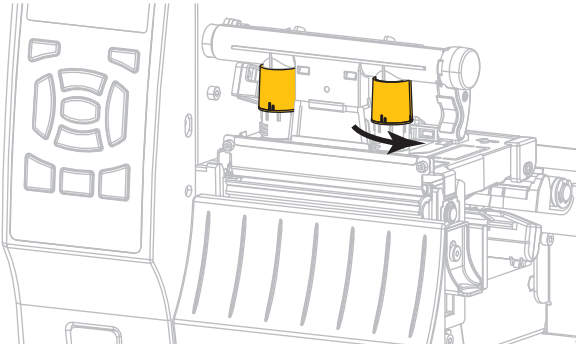
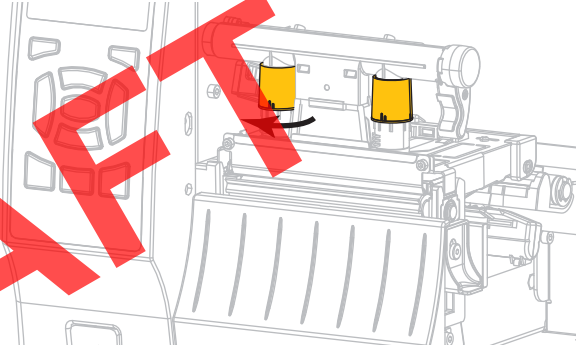
| If the media...            | Then...  |
|----------------------------|--|
| Shifts left while printing | <p data-bbox="829 268 1430 304">Increase the outside dial setting one position.</p>  <p data-bbox="829 699 1430 735">OR</p> <p data-bbox="829 741 1430 777">Decrease the inside dial setting one position.</p>  |

**DRAFT**

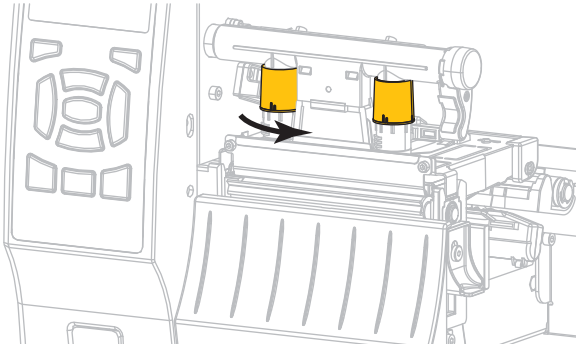
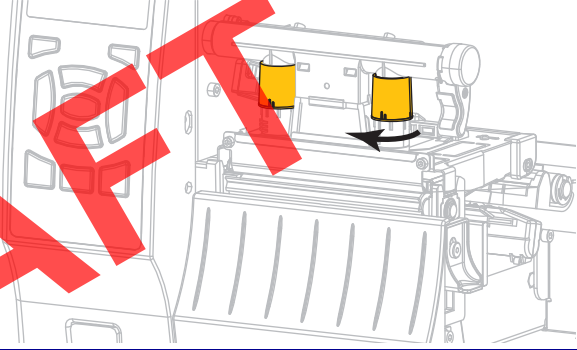
| If the media...             | Then...  |
|-----------------------------|--|
| Shifts right while printing | <p data-bbox="829 268 1429 304">Increase the inside dial setting one position.</p>  <p data-bbox="829 699 1429 730">OR</p> <p data-bbox="829 741 1429 772">Decrease the outside dial setting one position.</p>  |

DRAFT

## Routine Maintenance

This section provides routine cleaning and maintenance procedures.

### Contents

|  |     |
|--|-----|
| Cleaning Schedule and Procedures . . . . .                           | 98  |
| Clean the Exterior, the Media Compartment, and the Sensors . . . . . | 99  |
| Clean the Printhead and Platen Roller . . . . .                      | 102 |
| Clean and Lubricate the Cutter Module . . . . .                      | 110 |
| Replacing Printer Components . . . . .                               | 115 |
| Ordering Replacement Parts . . . . .                                 | 115 |
| Recycling Printer Components . . . . .                               | 115 |
| Lubrication . . . . .  | 115 |

## Cleaning Schedule and Procedures

Routine preventive maintenance is a crucial part of normal printer operation. By taking good care of your printer, you can minimize the potential problems that you might have with it and help to achieve and to maintain your standards for print quality.

Over time, the movement of media or ribbon across the printhead wears through the protective ceramic coating, exposing and eventually damaging the print elements (dots). To avoid abrasion:

- Clean the printhead frequently.
- Minimize printhead pressure and burn temperature (darkness) settings by optimizing the balance between the two.
- When using Thermal Transfer mode, ensure that the ribbon is as wide or wider than the media to prevent exposing the printhead elements to the more abrasive label material.



**Important** • Zebra is not responsible for damage caused by the use of cleaning fluids on this printer.

Specific cleaning procedures are provided on the following pages. Table 4 shows the recommended cleaning schedule. These intervals are intended as guidelines only. You may have to clean more often, depending upon your application and media.

**Table 4 • Recommended Cleaning Schedule**

| Area                                   |   | Method                | Interval   |
|--|---|-----------------------|--|
| Printhead                              |   | Solvent*              | <b>Direct Thermal Mode:</b> After every roll of media (or 500 feet of fanfold media).<br><b>Thermal Transfer Mode:</b> After every roll of ribbon. |
| Platen roller                          |   | Solvent*              |  |
| Media sensors                          |   | Air blow              |  |
| Ribbon sensor                          |   | Air blow              |  |
| Media path                             |   | Solvent*              |  |
| Ribbon path                            |   | Solvent*              |  |
| Pinch roller (part of Peel-Off option) |   | Solvent*              |  |
| Cutter module                          | If cutting continuous, pressure-sensitive media | Solvent*              | After every roll of media (or more often, depending upon your application and media).  |
|  | If cutting tag stock or label liner material    | Solvent* and air blow | After every two or three rolls of media.   |
| Tear-off/peel-off bar                  |   | Solvent*              | Once a month.  |
| Take-label sensor                      |   | Air blow              | Once every six months.   |

\* Zebra recommends using the Preventive Maintenance Kit (p/n 47362 or p/n 105950-035 - multipack). In place of this kit, you may use a clean swab dipped in 99.7% isopropyl alcohol.

For 600 dpi printers, use Save-a-Printhead cleaning film. This specially coated material removes contamination buildup without damaging the printhead. Call your authorized reseller or distributor for more information.

## Clean the Exterior, the Media Compartment, and the Sensors

Over time, dust, grime, and other debris may build up on the outside and inside of your printer, particularly in a harsh operating environment.

### Printer Exterior

You may clean the exterior surfaces of the printer with a lint-free cloth and a small amount of a mild detergent, if necessary. Do not use harsh or abrasive cleaning agents or solvents.



**Important** • Zebra is not responsible for damage caused by the use of cleaning fluids on this printer.

### Media Compartment and Sensors

To clean the sensors, complete these steps:

1. Brush, air blow, or vacuum any accumulated paper lint and dust away from the media and ribbon paths.
2. Brush, air blow, or vacuum any accumulated paper lint and dust away from the sensors.

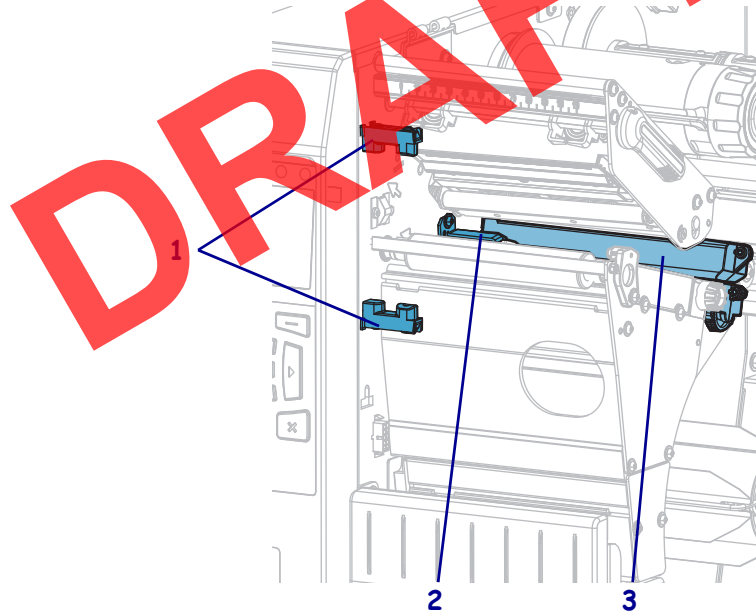

|          |                   |
|----------|-------------------|
| <b>1</b> | Take-label sensor |
| <b>2</b> | Ribbon sensor     |
| <b>3</b> | Media sensor      |

## Remove Used Ribbon

At minimum, remove used ribbon from the ribbon take-up spindle each time you change the roll of ribbon. With ribbon that is half or less the width of the printhead, remove used ribbon each time you load a new roll of media. This ensures that uneven pressure on the ribbon take-up spindle does not interfere with the ribbon release bars on the spindle.

### To remove used ribbon, complete these steps:

1. Has the ribbon run out?

| If the ribbon... | Then   |
|------------------|--|
| Ran out          | Continue with the next step.                               |
| Did not run out  | Cut or break the ribbon before the ribbon take-up spindle. |

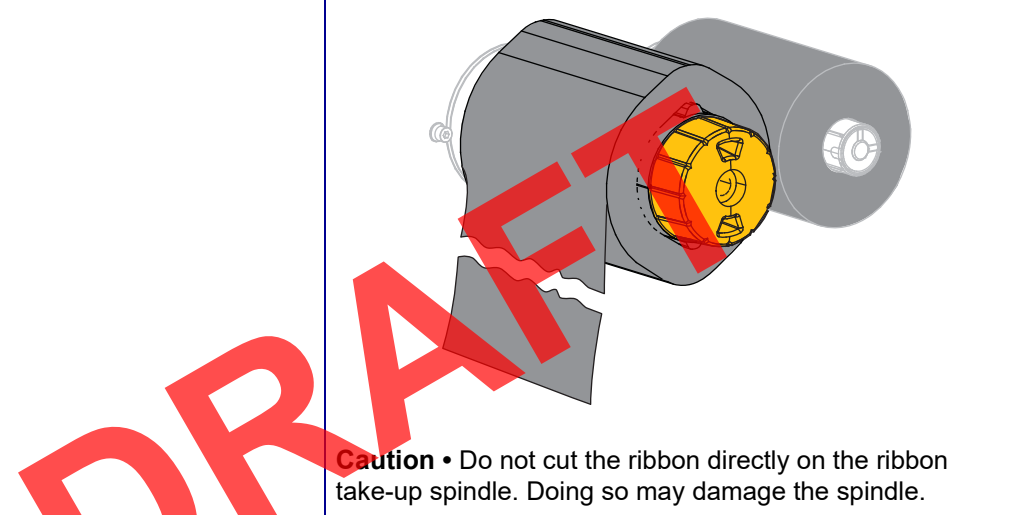

**Caution** • Do not cut the ribbon directly on the ribbon take-up spindle. Doing so may damage the spindle.

2. While holding the ribbon take-up spindle, turn the ribbon release knob to the left until it stops.

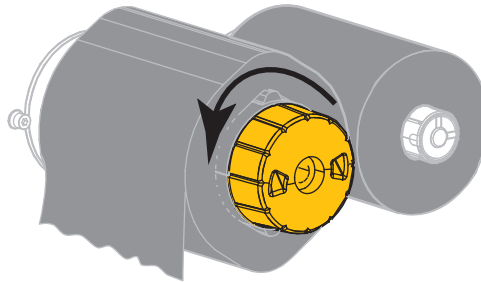

The ribbon release bars pivot down, easing the spindle's grip on the used ribbon.



3. After the ribbon release bars have pivoted down, if possible, turn the ribbon take-up spindle one full to the right to help loosen the ribbon on the spindle.
4. Slide the used ribbon off of the ribbon take-up spindle and discard.

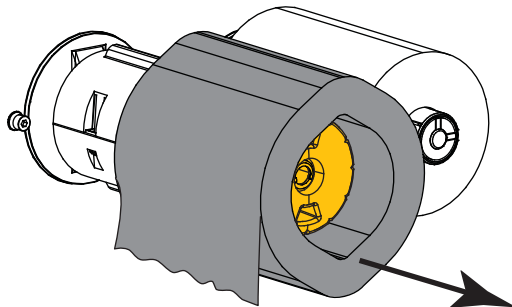

**DRAFT**

## Clean the Printhead and Platen Roller

Inconsistent print quality, such as voids in the bar code or graphics, may indicate a dirty printhead. For the recommended cleaning schedule, see [Table 4 on page 98](#).

---

**Caution** • While performing any tasks near an open printhead, remove all rings, watches, hanging necklaces, identification badges, or other metallic objects that could touch the printhead. You are not required to turn off the printer power when working near an open printhead, but Zebra recommends it as a precaution. If you turn off the power, you will lose all temporary settings, such as label formats, and you must reload them before you resume printing.

---



**Note** • For printers with a peel assembly, keep the peel assembly closed while cleaning the platen roller to reduce the risk of bending the tear-off/peel-off bar.



**Caution** • The printhead may be hot and could cause severe burns. Allow the printhead to cool.



**Caution** • Before touching the printhead assembly, discharge any built-up static electricity by touching the metal printer frame or by using an antistatic wriststrap and mat.

---

To clean the printhead and platen roller, complete these steps:

1. Raise the media door.

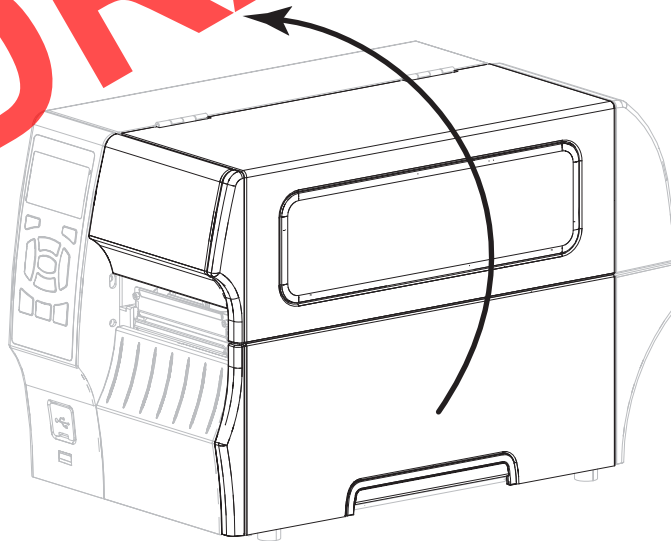



2. **Caution** • The printhead may be hot and could cause severe burns. Allow the printhead to cool.

Open the printhead assembly by rotating the printhead-open lever.

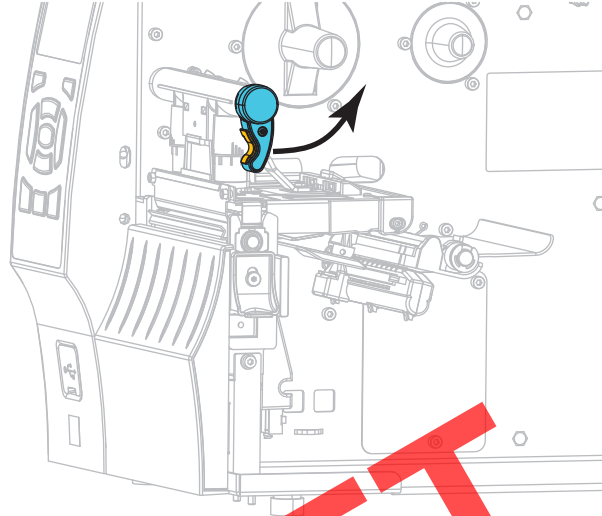

3. Remove the ribbon (if used) and the media.
4. Using the swab from a Zebra Preventive Maintenance Kit, wipe along the brown strip on the printhead assembly from end to end. In place of the Preventive Maintenance Kit, you may use a clean swab dipped in 99.7% isopropyl alcohol. Allow the solvent to evaporate.

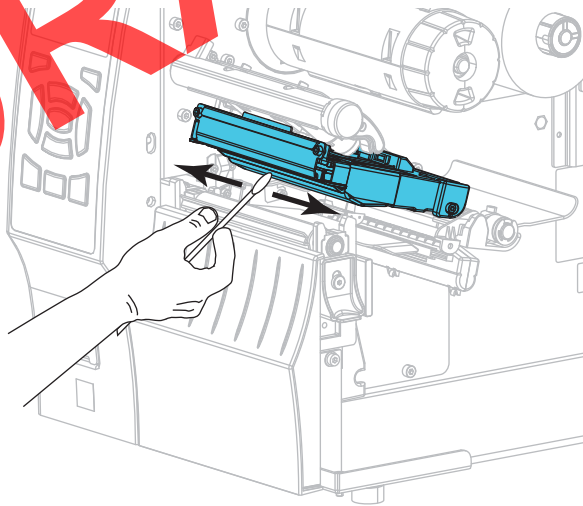

5. While manually rotating the platen roller, clean it thoroughly with the swab. Allow the solvent to evaporate.

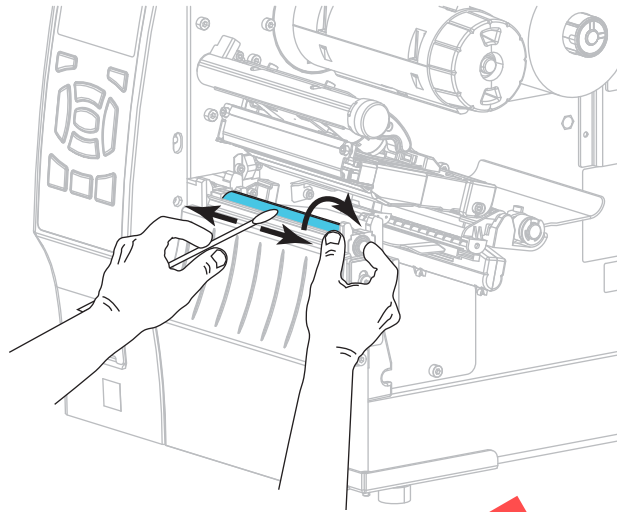

6. Reload the ribbon (if used) and the media. For instructions, see [Load the Ribbon on page 43](#) or [Load the Media on page 17](#).
7. Rotate the printhead-open lever downward until it locks the printhead in place.

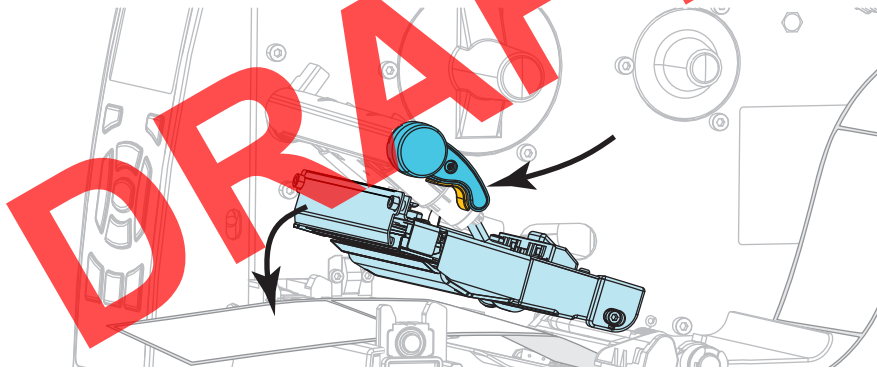

8. Close the media door.

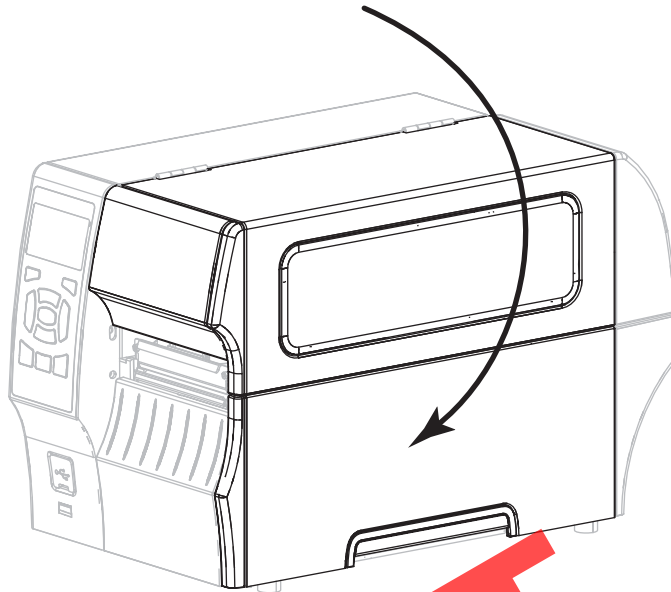

The printer is ready to operate.

9. Press PAUSE to exit pause mode and enable printing.

The printer may perform a label calibration or feed a label, depending on your settings.



**Note** • If performing this procedure does not improve print quality, try cleaning the printhead with *Save-A-Printhead* cleaning film. This specially coated material removes contamination buildup without damaging the printhead. Call your authorized Zebra reseller for more information.

## Clean the Peel Assembly

The peel assembly, which is part of the Peel-Off and Liner Take-Up options, consists of several spring-loaded rollers to ensure the proper roller pressure. Clean the pinch roller and tear-off/peel-off bar if adhesive buildup begins to affect peel performance.



---

**Caution** • Do not use your left hand to assist in closing the Peel assembly. The top edge of the Peel roller/assembly could pinch your fingers.

---

### If adhesive buildup affects peel-off performance, complete these steps:

1. Raise the media door.

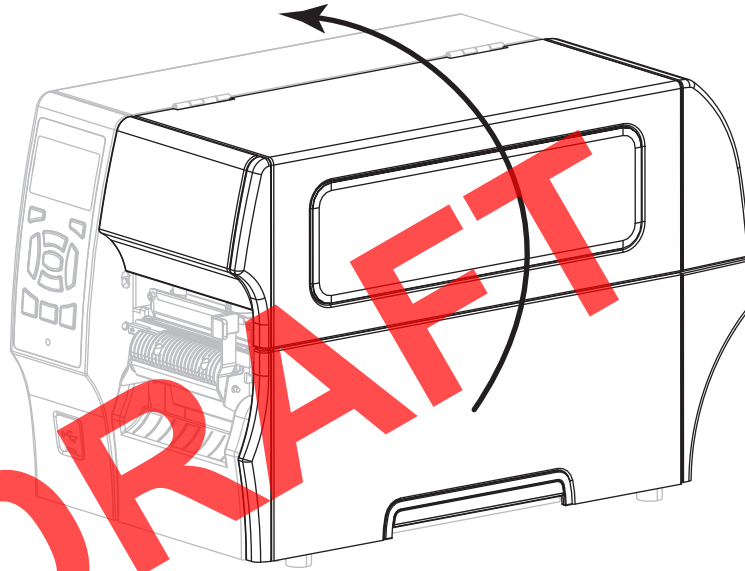

2. **Caution** • The printhead may be hot and could cause severe burns. Allow the printhead to cool.

Open the printhead assembly by rotating the printhead-open lever.

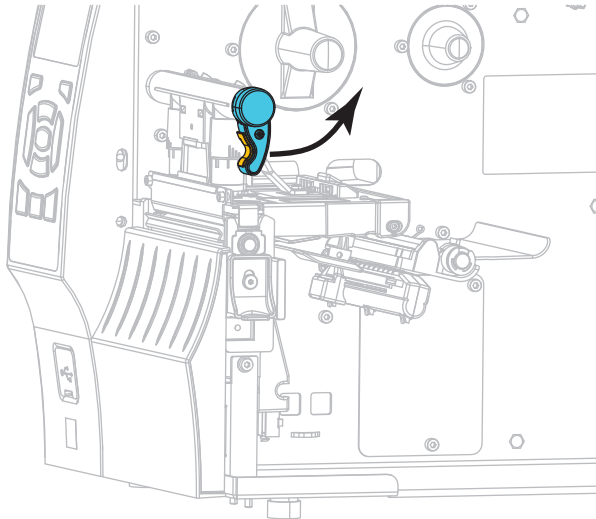

3. Push down the peel-off mechanism release lever to open the peel assembly.

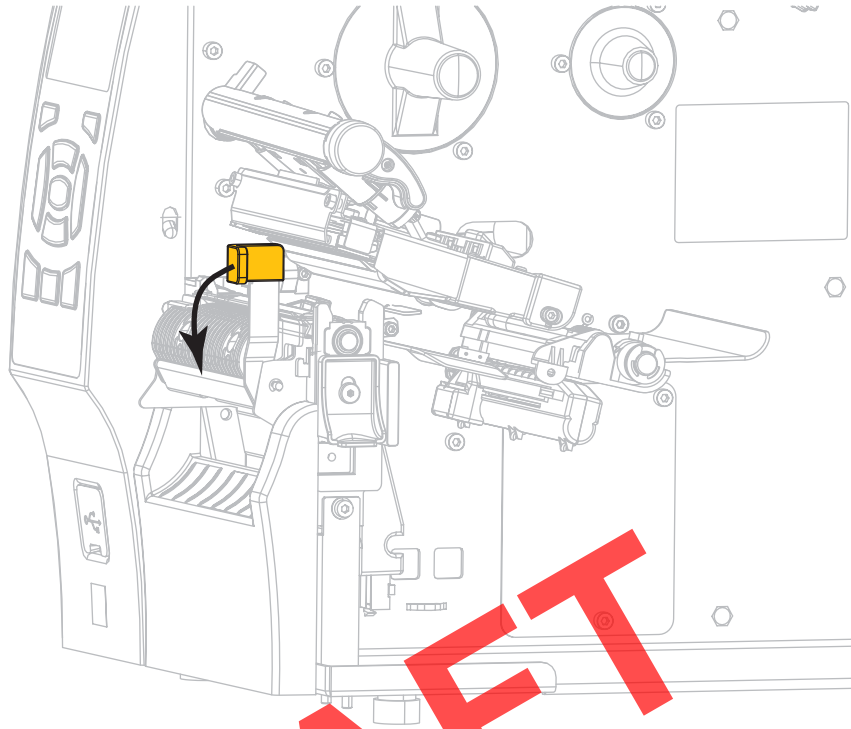

4. Remove any media liner to expose the pinch roller.
5. While manually rotating the pinch roller, clean it thoroughly with the swab from the Preventive Maintenance Kit (part number 47362). In place of the Preventive Maintenance Kit, you may use a clean swab dipped in 99.7% isopropyl alcohol. Allow the solvent to evaporate.

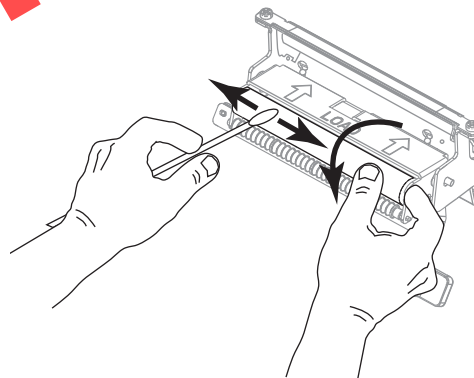

6. Use the swab to remove excess adhesive from the tear-off/peel-off bar. Allow the solvent to evaporate.



**Important** • Apply minimum force when cleaning the tear-off/peel-off bar. Excessive force can cause the tear-off/peel-off bar to bend, which could have a negative effect on peel performance.

7. Reload the media liner through the peel mechanism. For instructions, see *Final Steps for Peel-Off Mode (with or without Liner Take-Up)* on page 25.



8. **Caution** • Use the peel release lever and your right hand to close the peel assembly. Do not use your left hand to assist in closing. The top edge of the peel roller/assembly could pinch your fingers.

Close the peel assembly using the peel-off mechanism release lever.

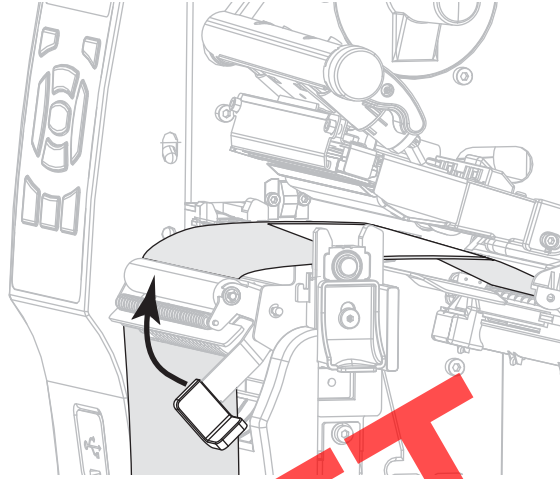

9. Rotate the printhead-open lever downward until it locks the printhead in place.

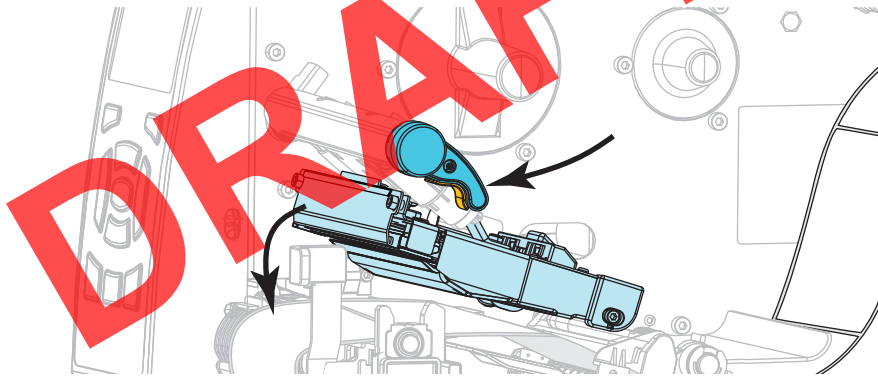



10. Close the media door.

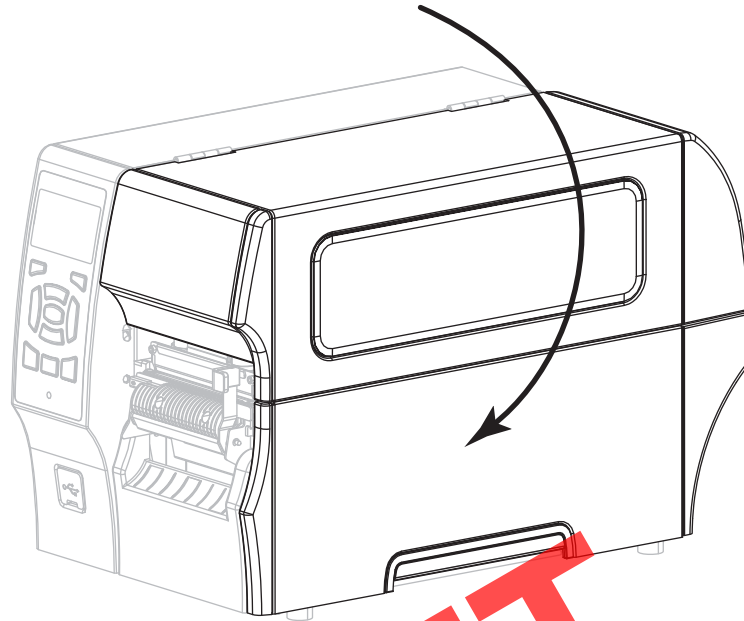

The printer is ready to operate.

11. Press PAUSE to exit pause mode and enable printing.  
The printer may perform a label calibration or feed a label, depending on your settings.

**DRAFT**

## Clean and Lubricate the Cutter Module

If the cutter is not cutting the labels cleanly or if it jams with labels, clean the cutter blades. After cleaning the blades, apply lubrication to them to help extend the life of your cutter module.

### To clean the cutter module, complete these steps:



1. **Caution** • Turn off (O) the printer and disconnect it from the power source before performing the following procedure.

Turn off (O) the printer and disconnect the AC power cord.

2. Raise the media door.

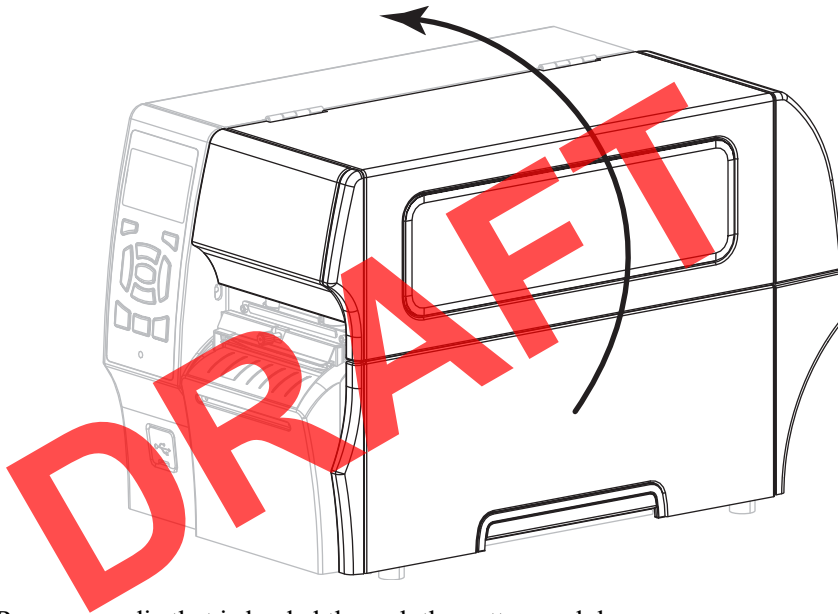

3. Remove media that is loaded through the cutter module.
4. Loosen and remove the thumbscrew and lock washer on the cutter shield.

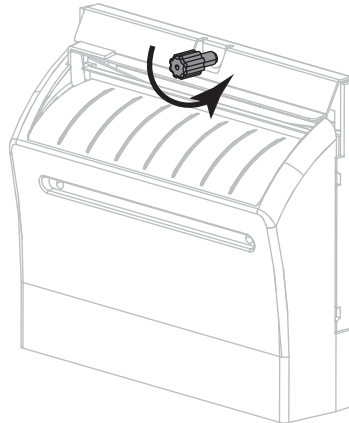



5. **Caution** • The cutter blade is sharp. Do not touch or rub the blade with your fingers.

Remove the cutter shield.

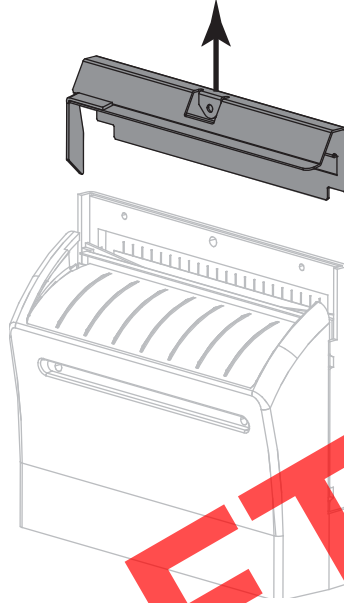

6. If necessary, rotate the cutter motor thumbscrew to fully expose the V-shaped cutter blade (1).

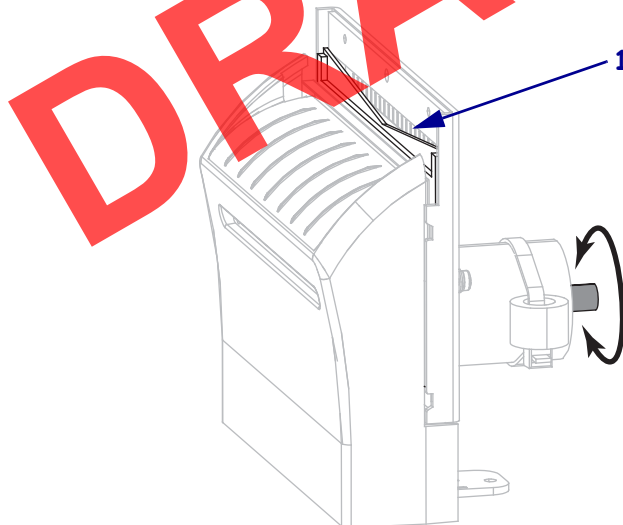

7. Using the swab from the Preventive Maintenance Kit (part number 47362), wipe along the upper cutting surface and the cutter blade. In place of the Preventive Maintenance Kit, you may use a clean swab dipped in 99.7% isopropyl alcohol. Allow the solvent to evaporate.

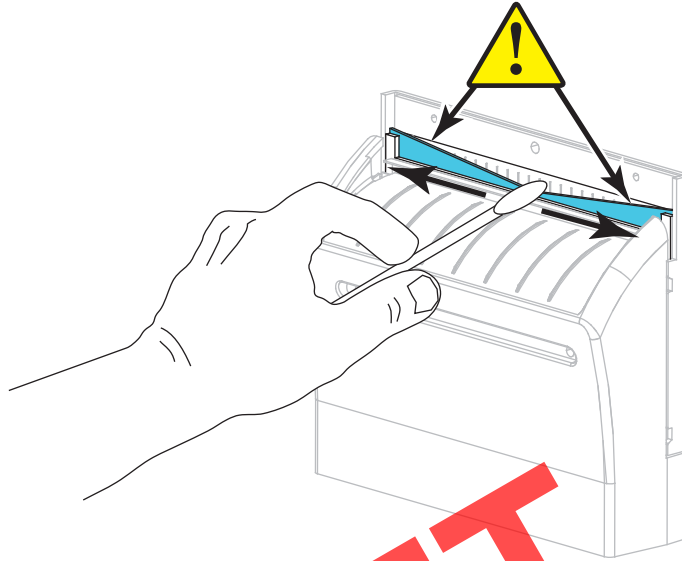

8. When the solvent has evaporated, soak a clean swab in a general-purpose, higher-viscosity silicone or PTFE oil lubricant.



9. Apply an even layer along all exposed surfaces of both cutter blades. Remove any excess oil so that none of it comes in contact with the printhead or platen roller.

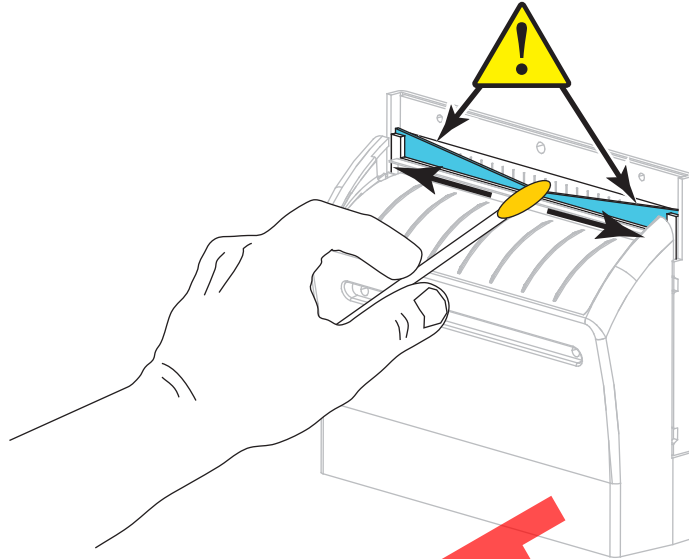

10. **Caution** • The cutter blade is sharp. For operator safety, replace the cutter shield.

Replace the cutter shield (1) and secure it with the thumbscrew and lock washer that you removed earlier (2).

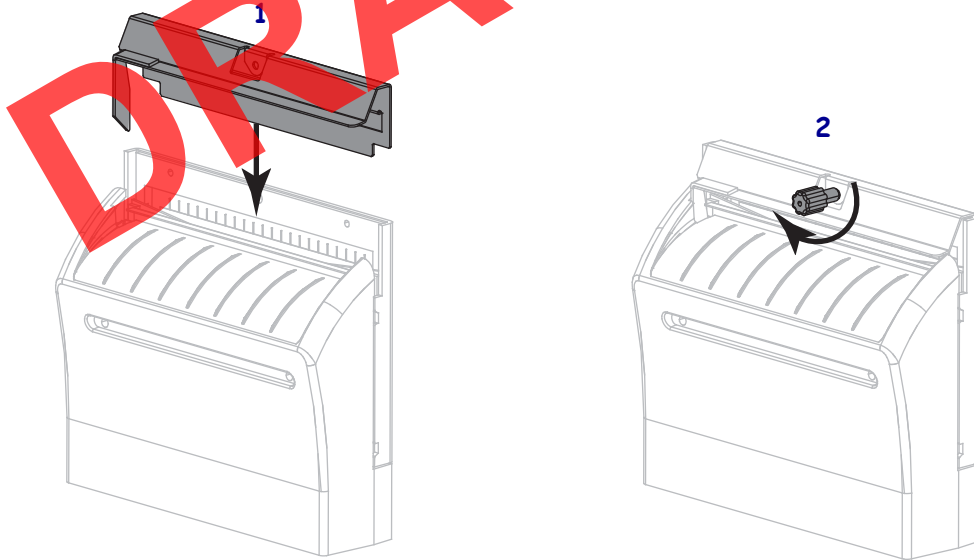

11. Close the media door.

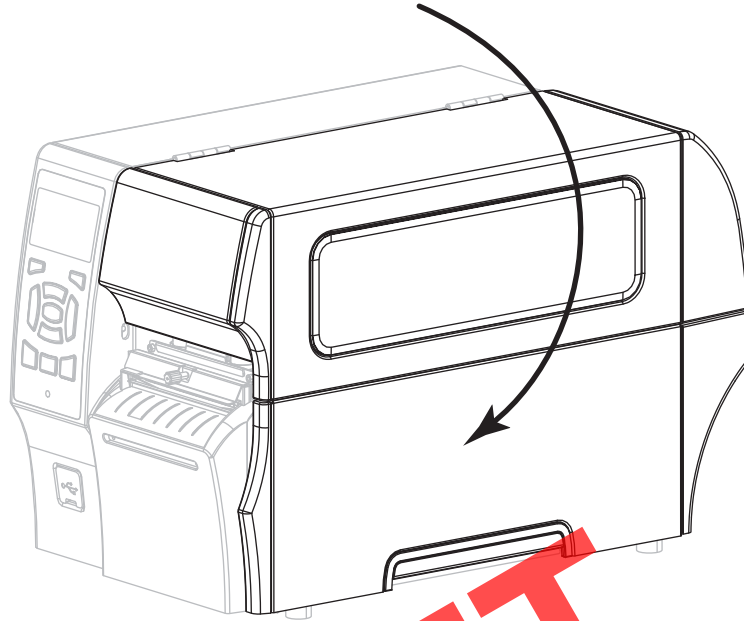

12. Plug the printer into its power source, and then turn on (I) the printer.  
The cutter blade returns to its operating position.
13. If the cutter continues to perform unsatisfactorily, contact an authorized service technician.

**DRAFT**

## Replacing Printer Components

Some printer components, such as the printhead and platen roller, may wear out over time and can be replaced easily. Regular cleaning may extend the life of some of these components. See [Table 4 on page 98](#) for the recommended cleaning intervals.

## Ordering Replacement Parts

Zebra™ printers are designed to work only with genuine Zebra printheads, thus maximizing safety and print quality. Contact your authorized Zebra reseller for part ordering information.

## Recycling Printer Components



The majority of this printer's components are recyclable. The printer's main logic board may include a battery that you should dispose of properly.

Do not dispose of any printer components in unsorted municipal waste. Please dispose of the battery according to your local regulations, and recycle the other printer components according to your local standards. For more information, see <http://www.zebra.com/environment>.

## Storing the Printer

If you are not placing the printer into immediate operation, repackage it using the original packing materials. You may store the printer under the following conditions:

- Temperature: -40°F to 140°F (-40° to 60°C)
- Relative humidity: 5% to 85% non-condensing

## Lubrication

No lubrication is needed for this printer.

---

**Caution** • Some commercially available lubricants will damage the finish and the mechanical parts if used on this printer.

---

**DRAFT**



# Diagnostics and Troubleshooting

This section provides diagnostic tests and other information that may help you to optimize printing or to troubleshoot issues with your printer.



Go to [www.zebra.com/zt600-info](http://www.zebra.com/zt600-info) for access to videos and additional online information designed to assist you.

## Contents

|  |     |
|--|-----|
| Judging Barcode Quality . . . . .            | 118 |
| Configuration Labels . . . . .               | 120 |
| PAUSE Self Test . . . . .                    | 121 |
| Sensor Profile . . . . .                     | 122 |
| Communication Diagnostics Mode . . . . .     | 123 |
| Load Defaults or Last Saved Values . . . . . | 124 |
| Alert and Error States . . . . .             | 125 |
| Alerts and Error Messages . . . . .          | 126 |
| Indicator Lights . . . . .                   | 129 |
| Troubleshooting . . . . .                    | 131 |
| Printing or Print Quality Issues . . . . .   | 131 |
| Ribbon Issues . . . . .                      | 136 |
| RFID Issues . . . . .                        | 138 |
| Communications Issues . . . . .              | 141 |
| Miscellaneous Issues . . . . .               | 142 |
| Service the Printer . . . . .                | 146 |
| Ship the Printer . . . . .                   | 146 |

## Judging Barcode Quality

Figure 3 shows how printer settings such as darkness and print speed can affect the quality of barcodes. Set the print darkness to the lowest setting that provides good print quality. The Print Quality Assistant in *Run the Print Wizard and Print a Test Label on page 49* can help you determine the best settings.

Figure 3 • Barcode Darkness Comparison

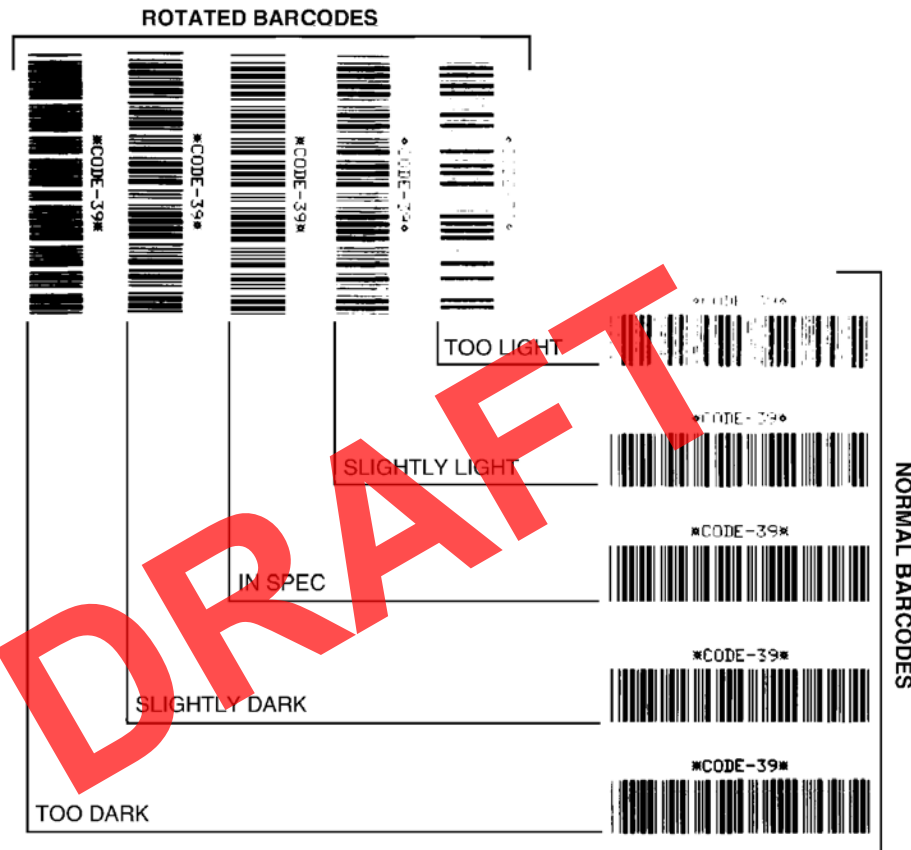

**Too Dark** Labels that are too dark are fairly obvious. They may be readable but not “in-spec.”

- The normal barcode bars increase in size.
- The openings in small alphanumeric characters may fill in with ink.
- Rotated barcode bars and spaces run together.

**Slightly Dark** Slightly dark labels are not as obvious.

- The normal barcode will be “in-spec.”
- Small character alpha numerics will be bold and could be slightly filled in.
- The rotated barcode spaces are small when compared to the “in-spec” code, possibly making the code unreadable.

**“In-Spec”** The “in-spec” barcode can only be confirmed by a verifier, but it should exhibit some visible characteristics.

- The normal barcode will have complete, even bars and clear, distinct spaces.
- The rotated barcode will have complete, even bars and clear, distinct spaces. Although it may not look as good as a slightly dark barcode, the barcode will be “in-spec.”
- In both normal and rotated styles, small alphanumeric characters look complete.

**Slightly Light** Slightly light labels are, in some cases, preferred to slightly dark ones for “in-spec” barcodes.

- Both normal and rotated barcodes will be in spec, but small alphanumeric characters may not be complete.

**Too Light** Labels that are too light are obvious.

- Both normal and rotated barcodes have incomplete bars and spaces.
- Small alphanumeric characters are unreadable.

**DRAFT**

## Configuration Labels

Some of the most commonly used diagnostic items are the printer configuration label and the network configuration label. Sample labels are shown in Figure 4. Analyzing the information on these labels can help you to troubleshoot potential issues.

To print a printer configuration label, touch Menu > Settings > Print: System Settings.

To print a network configuration label, touch Menu > Networks > Print: Network Info.

Figure 4 • Sample Labels

Printer Configuration Label

Network Configuration Label

| PRINTER CONFIGURATION                                       |                    |
|---|--------------------|
| Zebra Technologies<br>ZTC ZT620R-203dpi ZPL<br>76J162700886 |                    |
| +30.0.....  | DARKNESS           |
| 6.0 IPS.....  | PRINT SPEED        |
| -007.....   | TEAR OFF           |
| TEAR OFF.....   | PRINT MODE         |
| CONTINUOUS.....   | MEDIA TYPE         |
| TRANSMISSIVE.....   | SENSOR SELECT      |
| DIRECT-THERMAL.....   | PRINT METHOD       |
| 1344.....   | PRINT WIDTH        |
| 2000.....   | LABEL LENGTH       |
| P1085892/00005 2.....                                       | PRINT HEAD ID      |
| 15.01N 380MM.....   | MAXIMUM LENGTH     |
| MAINT. OFF.....   | EARLY WARNING      |
| CONNECTED.....  | USB COMM.          |
| BIDIRECTIONAL.....  | PARALLEL COMM.     |
| RS232.....  | SERIAL COMM.       |
| 9600.....   | BAUD               |
| 8 BITS.....   | DATA BITS          |
| NONE.....   | PARITY             |
| XON/XOFF.....   | HOST HANDSHAKE     |
| NONE.....   | PROTOCOL           |
| NORMAL MODE.....  | COMMUNICATIONS     |
| <>> 7EH.....  | CONTROL PREFIX     |
| <>> 5EH.....  | FORMAT PREFIX      |
| <>> 2CH.....  | DELIMITER CHAR     |
| ZPL II.....   | ZPL MODE           |
| INACTIVE.....   | COMMAND OVERRIDE   |
| FEED.....   | FEED PULSER UP     |
| LENGTH.....   | HEAD CLOSE         |
| DEFAULT.....  | BACKFEED           |
| +000.....   | LABEL TOP          |
| +0000.....  | SET POSITION       |
| OFF.....  | APPLICATOR PORT    |
| ENABLED.....  | ERRORS ON PAUSE    |
| DISABLED.....   | START PRINT SIG    |
| 00.....   | RESPRINT MODE      |
| 090.....  | WEB SENSOR         |
| 255.....  | MEDIA SENSOR       |
| 027.....  | TAKE LABEL         |
| 000.....  | MARK SENSOR        |
| 065.....  | MARK MED SENSOR    |
| 081.....  | TRANS GAIN         |
| 002.....  | TRANS BASE         |
| 100.....  | TRANS LED          |
| DPCS.....   | MARK GAIN          |
| 1344 8/MM FULL.....   | MARK LED           |
| 4.0.....  | MODES ENABLED      |
| V80.20.03 <.....  | MODES DISABLED     |
| 1.3.....  | RESOLUTION         |
| 6.6.0 22.89.....  | LINK-OS VERSION    |
| 32768k.....   | FIRMWARE           |
| 524288k.....  | WHL SCHEMA         |
| NONE.....   | RAM                |
| MM/DD/YYYY 24HR.....  | ONBOARD FLASH      |
| 05/11/17.....   | FORMAT CONVERT     |
| 06:40.....  | IDLE DISPLAY       |
| ENABLED.....  | RTC DATE           |
| 2.1.....  | RTC TIME           |
| READY.....  | ZBI                |
| 1M:MBE MICRO.....   | ZBI VERSION        |
| 20.00.00.01.....  | ZBI STATUS         |
| 01.03.00.18.....  | RFID READER        |
| USA/CANADA.....   | RFID HJ VERSION    |
| USA/CANADA.....   | RFID FW VERSION    |
| RFID OK.....  | RFID REGION CODE   |
| 16.....   | RFID REGION CODE   |
| 16.....   | RFID COUNTRY CODE  |
| F0.....   | RFID COUNTRY CODE  |
| 0.....  | RFID ERR STATUS    |
| 0.....  | RFID READ PHR      |
| NONE.....   | RFID WRITE PHR     |
| A4.....   | PROG. POSITION     |
| 570 LABELS.....   | RFID VALID CTR     |
| 570 LABELS.....   | RFID VOID CTR      |
| 570 LABELS.....   | ADAPTIVE ANTENNA   |
| 2.798 IN.....   | RFID ANTENNA       |
| 2.798 IN.....   | NONRESET CNTR      |
| 7.107 CM.....   | RESET CNTR1        |
| 7.107 CM.....   | RESET CNTR2        |
| 7.107 CM.....   | NONRESET CNTR      |
| 001 WIRELESS.....   | RESET CNTR1        |
| *** EMPTY.....  | RESET CNTR2        |
| 0.....  | SLOT 1             |
| 0.....  | SLOT 2             |
| OFF.....  | MASS STORAGE COUNT |
| 0.....  | HID COUNT          |
| 0.....  | USB HOST LOCK OUT  |
| FIRMWARE IN THIS PRINTER IS COPYRIGHTED                     |                    |

| Network Configuration                                       |                    |
|---|--------------------|
| Zebra Technologies<br>ZTC ZT620R-203dpi ZPL<br>76J162700886 |                    |
| Wired.....  | PRIMARY NETWORK    |
| INTERNAL WIRED.....   | LOAD LAN FROM?     |
|   | ACTIVE PRINTSRVR   |
| Wired*  |                    |
| ALL.....  | IP PROTOCOL        |
| 192.168.0.0.0.0.0.17.....                                   | IP ADDRESS         |
| 255.255.255.0.0.0.....                                      | SUBNET             |
| 192.168.0.0.254.....  | GATEWAY            |
| 0.0.0.0.0.0.0.0.0.0.....                                    | WINS SERVER IP     |
| YES.....  | TIMEOUT CHECKING   |
| 300.....  | TIMEOUT VALUE      |
| 000.....  | ARP INTERVAL       |
| 9100.....   | BASE RAW PORT      |
| 9200.....   | JSON CONFIG PORT   |
| Wireless  |                    |
| ALL.....  | IP PROTOCOL        |
| 0.0.0.0.0.0.0.0.0.0.....                                    | IP ADDRESS         |
| 255.255.255.0.0.0.....                                      | SUBNET             |
| 0.0.0.0.0.0.0.0.0.0.....                                    | GATEWAY            |
| 0.0.0.0.0.0.0.0.0.0.....                                    | WINS SERVER IP     |
| YES.....  | TIMEOUT CHECKING   |
| 300.....  | TIMEOUT VALUE      |
| 000.....  | ARP INTERVAL       |
| 9100.....   | BASE RAW PORT      |
| 9200.....   | JSON CONFIG PORT   |
| INSERTED.....   | CARD INSERTED      |
| 024FH.....  | CARD HFG ID        |
| 9134H.....  | CARD PRODUCT ID    |
| ac:3f:a4:82:05:9c.....                                      | MAC ADDRESS        |
| YES.....  | DRIVER INSTALLED   |
| INFRASTRUCTURE.....   | OPERATING MODE     |
| 125.....  | ESSID              |
| 1.0.....  | CURRENT TX RATE    |
| OPEN.....   | WEP TYPE           |
| WPA PSK.....  | WLAN SECURITY      |
| 1.....  | WEP INDEX          |
| 000.....  | POOR SIGNAL        |
| LONG.....   | PREAMBLE           |
| NO.....   | ASSOCIATED         |
| ON.....   | PULSE ENABLED      |
| 15.....   | PULSE RATE         |
| OFF.....  | INTL MODE          |
| USA/CANADA.....   | REGION CODE        |
| USA/CANADA.....   | COUNTRY CODE       |
| 0x7FF.....  | CHANNEL MASK       |
| Bluetooth   |                    |
| 4.3.1pl.....  | FIRMWARE           |
| 02/13/2015.....   | DATE               |
| 0.....  | DISCOVERABLE       |
| 3.0/4.0.....  | RADIO VERSION      |
| on.....   | ENABLED            |
| ac:3f:a4:82:05:9d.....                                      | MAC ADDRESS        |
| 76J162700886.....   | FRIENDLY NAME      |
| no.....   | CONNECTED          |
| 1.....  | MIN SECURITY MODE  |
| nc.....   | CONN SECURITY MODE |
| supported.....  | 10S                |
| FIRMWARE IN THIS PRINTER IS COPYRIGHTED                     |                    |