

TC25

Touch Computer



Quick Start Guide



ZEBRA

Copyright

© 2017 ZIH Corp. and/or its affiliates. All rights reserved. ZEBRA and the stylized Zebra head are trademarks of ZIH Corp., registered in many jurisdictions worldwide. All other trademarks are the property of their respective owners.

COPYRIGHTS & TRADEMARKS: For complete copyright and trademark information, go to www.zebra.com/copyright.

WARRANTY: For complete warranty information, go to www.zebra.com/warranty.

END USER LICENSE AGREEMENT: For complete EULA information, go to www.zebra.com/eula.

Terms of Use

- Proprietary Statement

This manual contains proprietary information of Zebra Technologies Corporation and its subsidiaries (“Zebra Technologies”). It is intended solely for the information and use of parties operating and maintaining the equipment described herein. Such proprietary information may not be used, reproduced, or disclosed to any other parties for any other purpose without the express, written permission of Zebra Technologies.

- Product Improvements

Continuous improvement of products is a policy of Zebra Technologies. All specifications and designs are subject to change without notice.

- Liability Disclaimer

Zebra Technologies takes steps to ensure that its published Engineering specifications and manuals are correct; however, errors do occur. Zebra Technologies reserves the right to correct any such errors and disclaims liability resulting therefrom.

- Limitation of Liability

In no event shall Zebra Technologies or anyone else involved in the creation, production, or delivery of the accompanying product (including hardware and software) be liable for any damages whatsoever (including, without limitation, consequential damages including loss of business profits, business interruption, or loss of business information) arising out of the use of, the results of use of, or inability to use such product, even if Zebra Technologies has been advised of the possibility of such damages. Some jurisdictions do not allow the exclusion or limitation of incidental or consequential damages, so the above limitation or exclusion may not apply to you.

Features

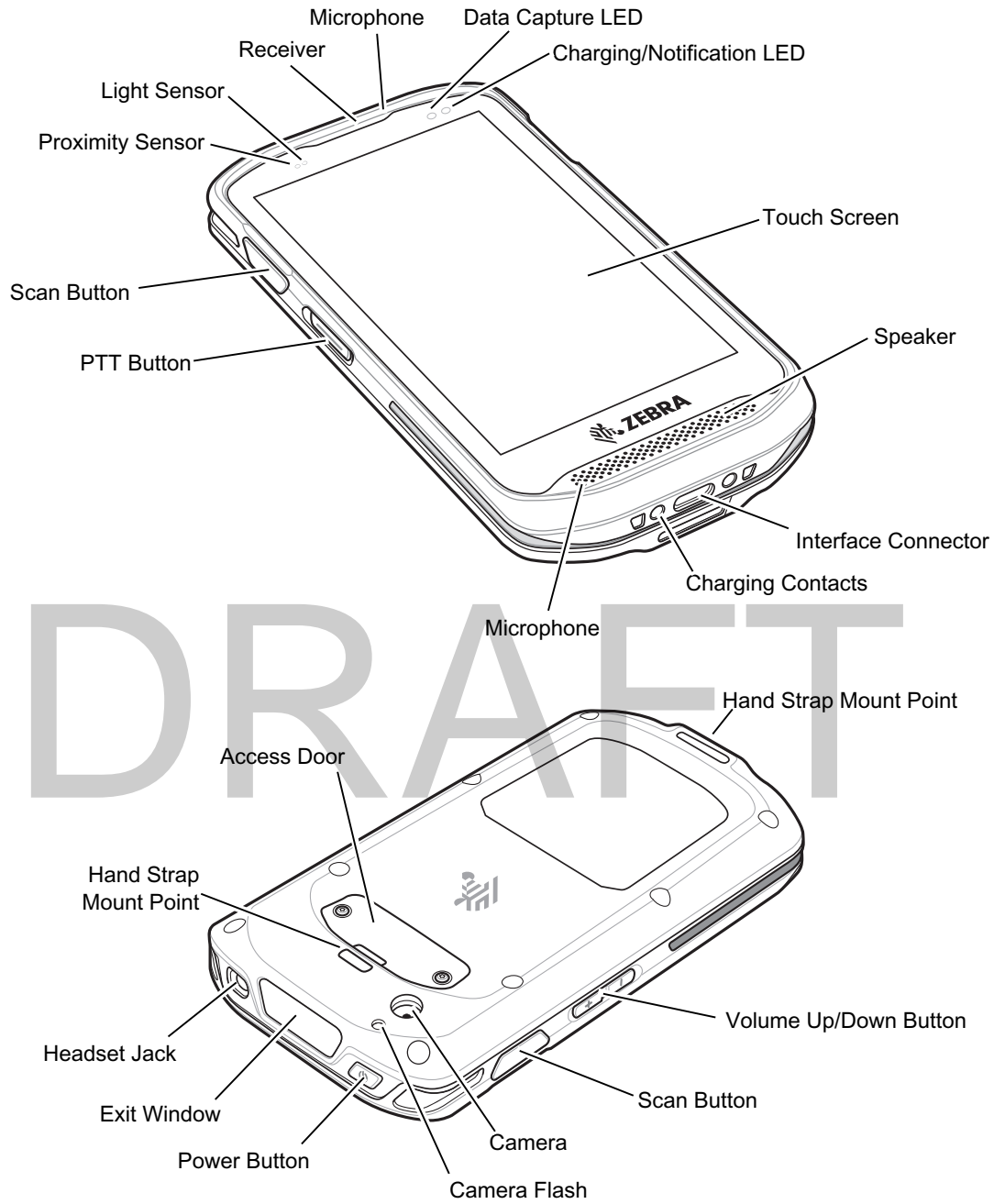

Installing a microSD Card

The microSD card slot provides secondary non-volatile storage. The slot is located under the battery pack. Refer to the documentation provided with the card for more information, and follow the manufacturer's recommendations for use.



CAUTION Follow proper electrostatic discharge (ESD) precautions to avoid damaging the microSD card. Proper ESD precautions include, but are not limited to, working on an ESD mat and ensuring that the operator is properly grounded.

1. Using a T4 Torx screwdriver, remove two screws securing the access door.

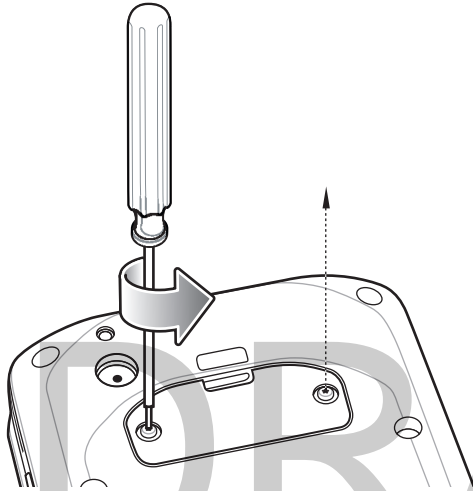

2. Remove access door.

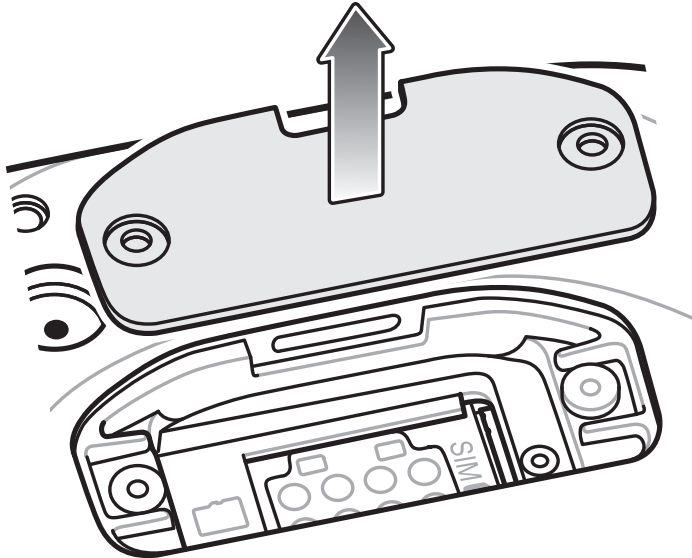

3. Align the microSD card with the SD card slot.

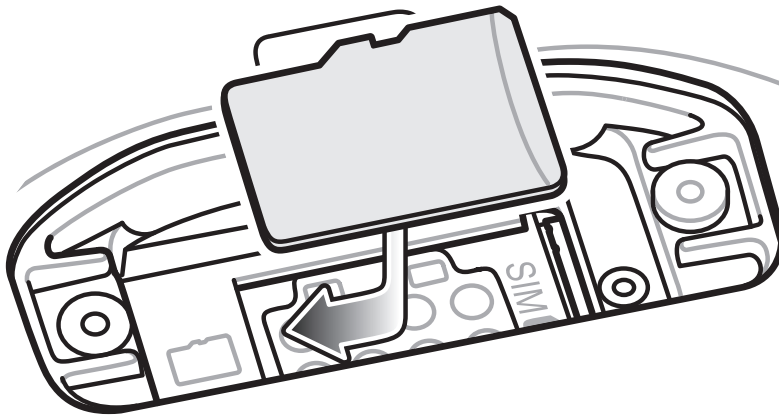

4. Push the microSD card into the SD card slot.

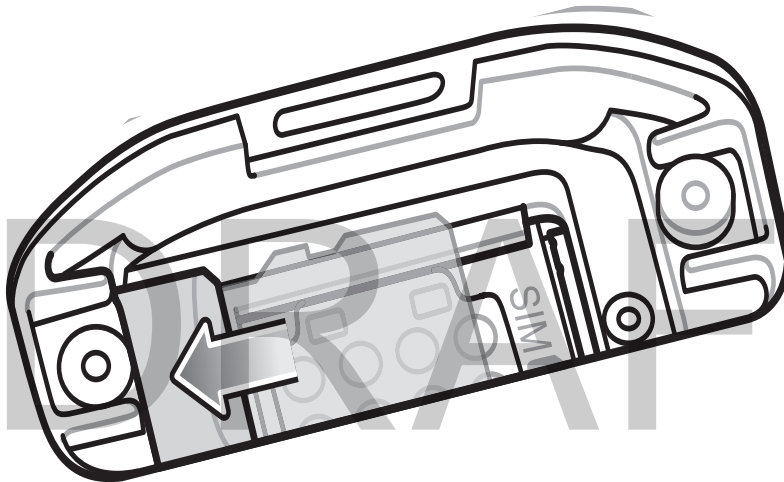

5. If installing a SIM card, skip to [Installing SIM Card on page 6](#)
6. Replace the access Door.
7. Secure the access door using the two screws.



CAUTION Access door must be replaced and securely seated to ensure proper device sealing.

8. Re-install the access door.

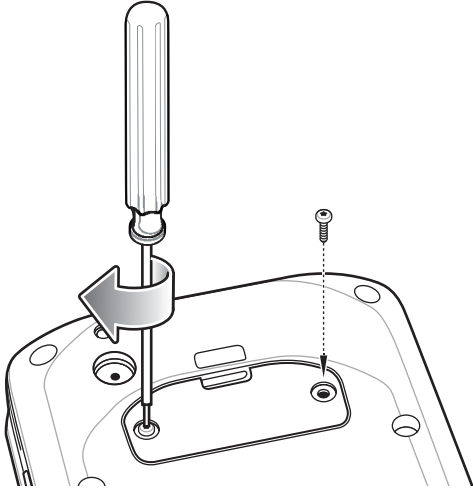

Installing SIM Card



NOTE Only use a nano SIM card.



CAUTION For proper electrostatic discharge (ESD) precautions to avoid damaging the SIM card. Proper ESD precautions include, but not limited to, working on an ESD mat and ensuring that the user is properly grounded.

To install a SIM card:

1. Using a T4 Torx screwdriver, remove two screws securing the access door.

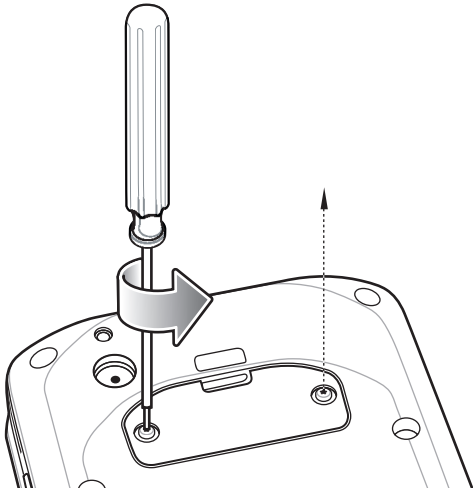

2. Remove access door.

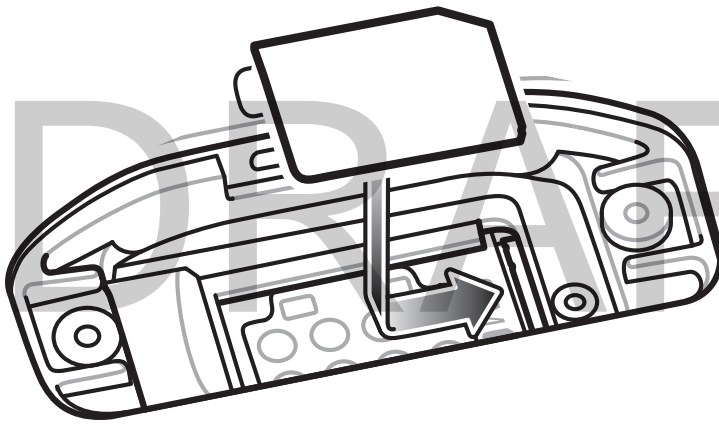
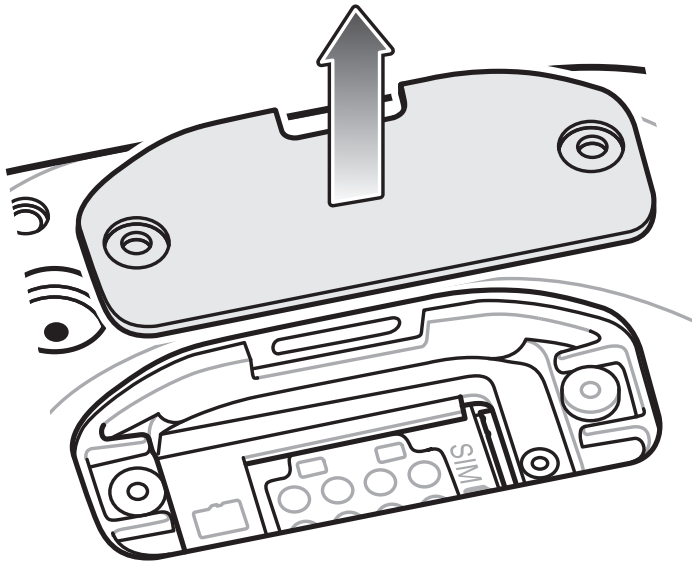

3. Align the SIM card with the SIM slot.

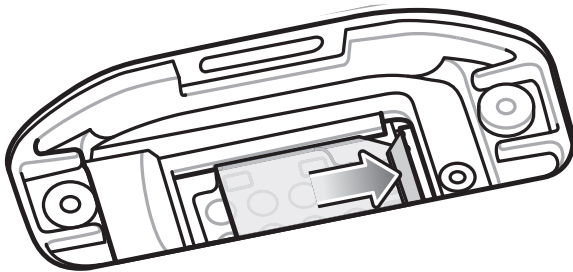

4. Push the SIM card into the SIM slot.



CAUTION Access door must be replaced and securely seated to ensure proper device sealing.

5. Replace the Access Door.

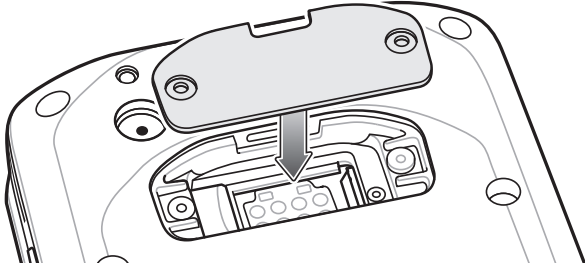

6. Secure door.

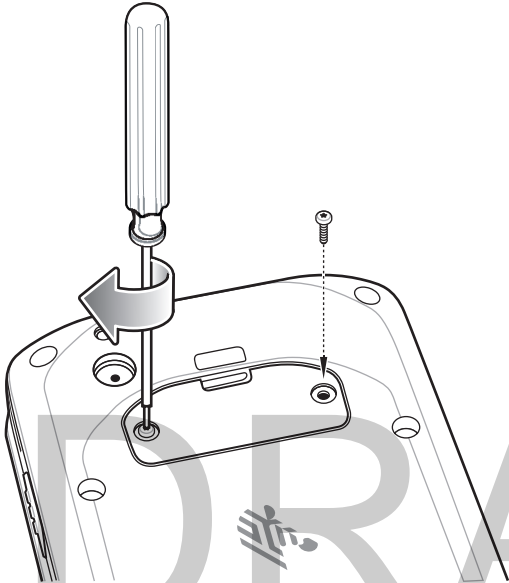

DRAFT 1

Charging the TC25

Use one of the following accessories to charge the TC25.

Table 1 Charging and Communication

Description	Part Number	Charging	Communication	
		Battery (In Device)	USB	Ethernet
1-Slot Charge Only Cradle	CRD-TC2X-BS1CO-01	Yes	No	No
1-Slot Ethernet Only Cradle	CRD-TC2X-SE1ET-01	Yes	Yes	With Optional Module
5-Slot Charge Only Cradle	CRD-TC2X-SE5CO-01	Yes	No	No
Extended Power Pack		Yes	No	No

Charging the TC25





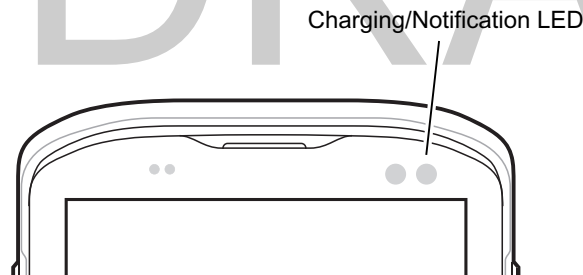

To charge the TC25:

1. To charge the internal battery, connect the charging accessory to the appropriate power source.
2. Insert the TC25 into a cradle or attach to a cable. The TC25 turns on and begins charging. The Charging/Notification LED blinks amber while charging, then turns solid green when fully charged.



The 3,000 mAh internal battery charges to 90% in less than 2.5 hours at room temperature.

Table 2 Charging/Notification LED Charging Indicators

State	LED	Indication
Off		TC25 is not charging. TC25 is not inserted correctly in the cradle or connected to a power source. Charger/cradle is not powered.
Slow Blinking Amber (1 blink every 4 seconds)		TC25 is charging.
Slow Blinking Red (1 blink every 4 seconds)		TC25 is charging but the battery is at end of useful life. See system administrator.
Solid Green		Charging complete.
Solid Red		Charging complete but the battery is at end of useful life. See system administrator.
Fast Blinking Amber (2 blinks/second)		Charging error, e.g.: <ul style="list-style-type: none"> • Temperature is too low or too high. • Charging has gone on too long without completion (typically eight hours).
Fast Blinking Red (2 blinks/second)		Charging error but the battery is at end of useful life., e.g.: <ul style="list-style-type: none"> • Temperature is too low or too high. • Charging has gone on too long without completion (typically eight hours). See system administrator.

Charge batteries in temperatures from 0°C to 40°C (32°F to 104°F). The device or cradle always performs battery charging in a safe and intelligent manner. At higher temperatures (e.g. approximately +37°C (+98°F)) the device or cradle may for small periods of time alternately enable and disable battery charging to keep the battery at acceptable temperatures. The device and cradle indicates when charging is disabled due to abnormal temperatures via its LED.

1-Slot Charge Only Cradle



1-Slot Ethernet Cradle

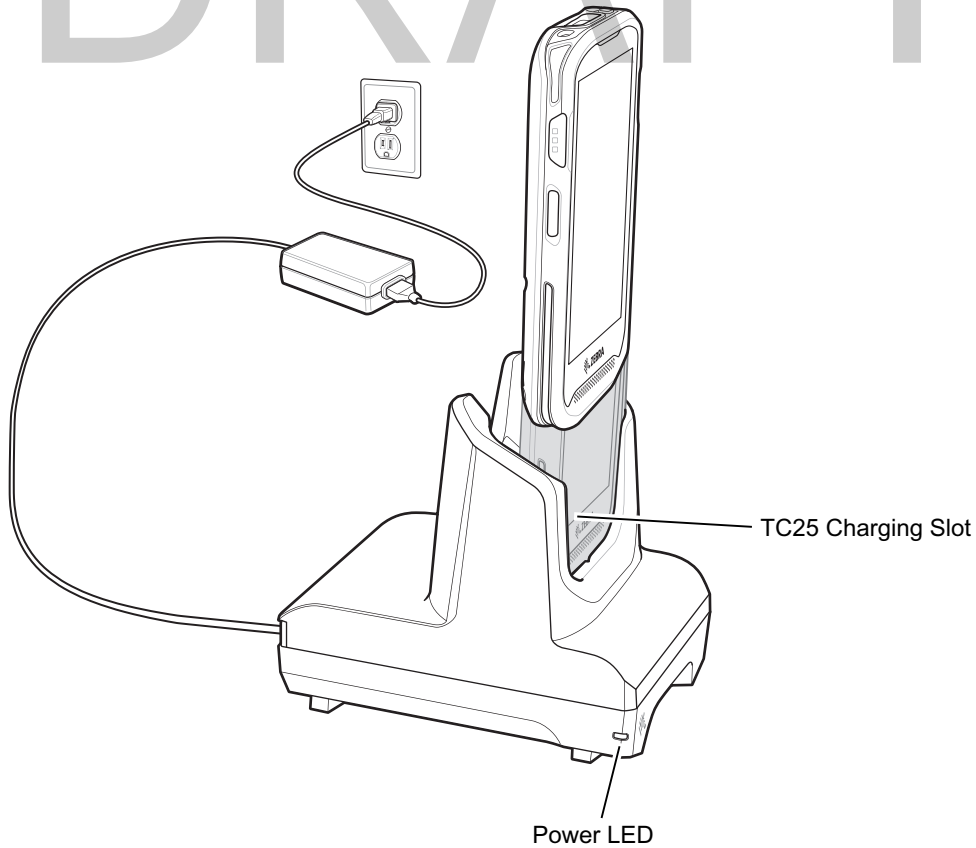

5-Slot Charge Only Cradle

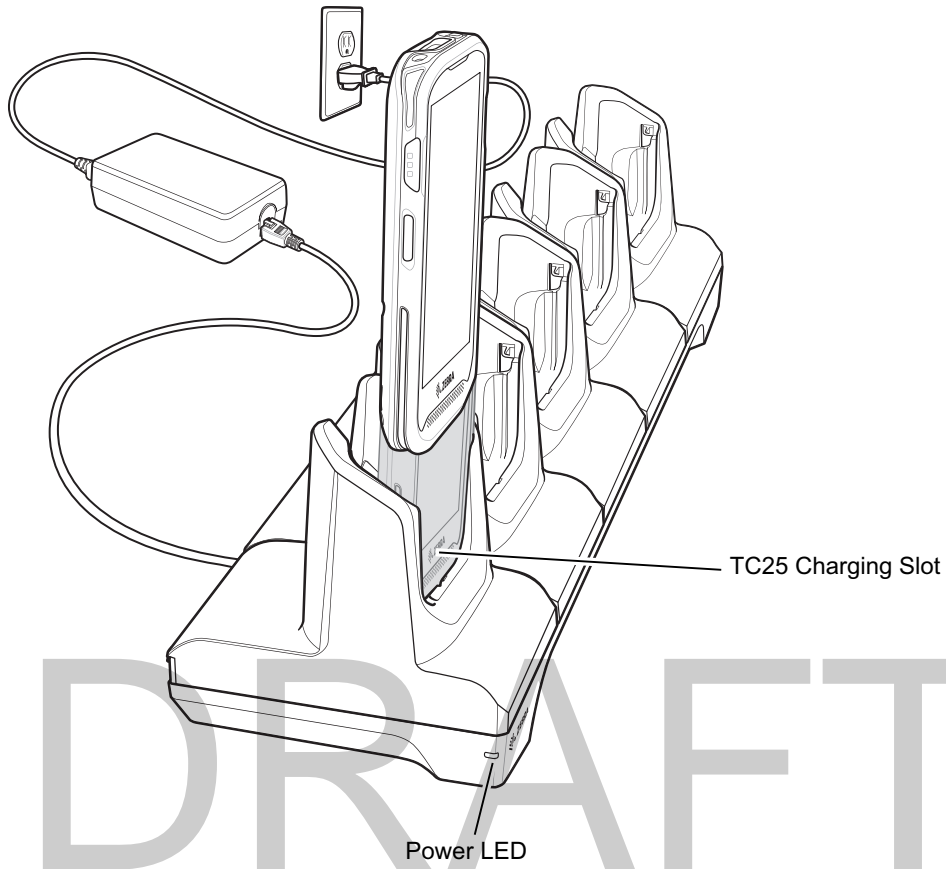

DRAFT 1

Extended Power Pack

Installation



Charging



DRAFT 1

Figure 1 Charging with USB Cable

Power Pack Charging

The Power Pack Charging LEDs indicate the status of charging. See [Table 15 on page 109](#) for charging status. The power pack charges from fully depleted to 90% in approximately ?? hours and from fully depleted to 100% in approximately ?? hours.

Charging Temperature

Charge batteries in temperatures from 0°C to 40°C (32°F to 104°F). The device or cradle always performs battery charging in a safe and intelligent manner. At higher temperatures (e.g. approximately +37°C (+98°F)) the device or cradle may for small periods of time alternately enable and disable battery charging to keep the battery at acceptable temperatures. The power pack indicates when charging is disabled due to abnormal temperatures via its LED.

Figure 2 Power Pack LEDs

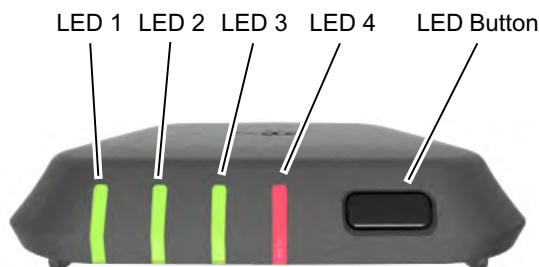

























Table 3 LED Charging Indicators

LED State				Indication
LED 1	LED 2	LED 3	LED 4	
				Not charging.
 Flashing				Charge level is between 0% and 33%.
 Solid	 Flashing			Charge level is between 33% and 66%.
 Solid	 Solid	 Flashing		Charge level is between 66% and 100%.
 Solid	 Solid	 Solid		Fully charged.
			 Flashing	Charging error, e.g.: <ul style="list-style-type: none"> • Temperature is too low or too high. • Charging has gone on too long without completion (typically eight hours).

Check Power Level

To check the power level of the pack, press the LED button. The LEDs light indicating the charge level. After five seconds the LEDs turn off.

Table 4 LED Charge State Indicators





















LED State				Indication
LED 1	LED 2	LED 3	LED 4	
				No charge.
 Flashing				Charge level is between 0% and 33%.
 Solid	 Flashing			Charge level is between 33% and 66%.

Table 4 LED Charge State Indicators *(continued)*

LED State				Indication
LED 1	LED 2	LED 3	LED 4	
 Solid	 Solid	 Flashing		Charge level is between 66% and 100%.
 Solid	 Solid	 Solid		Fully charged.

DRAFT 1

Trigger Handle

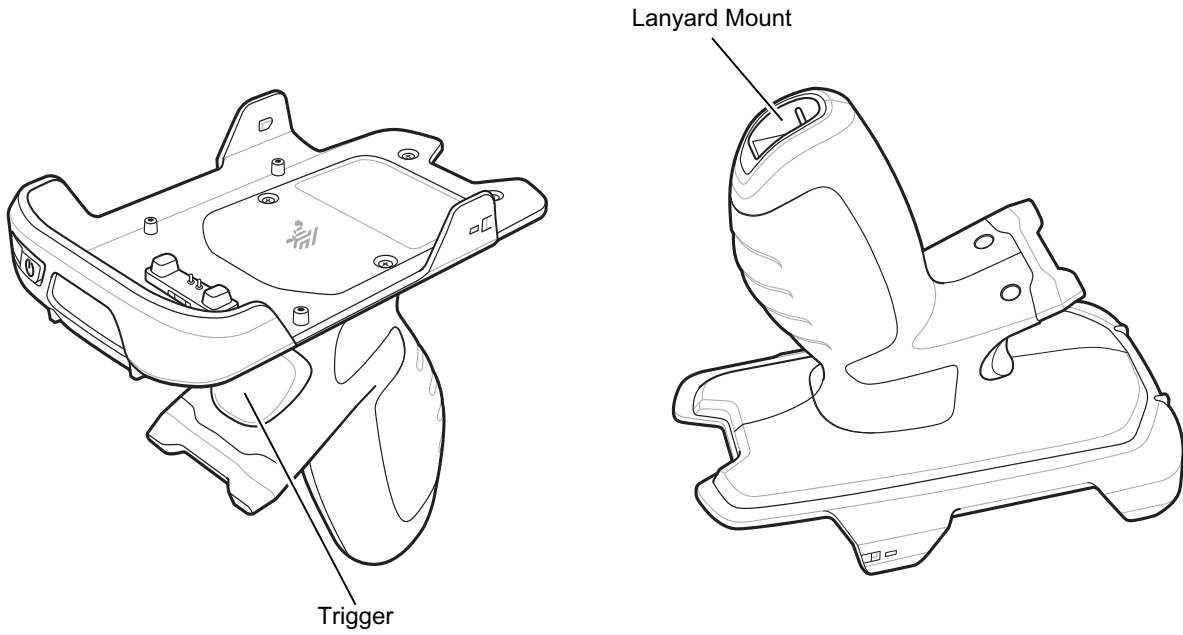

Installing the Optional Lanyard

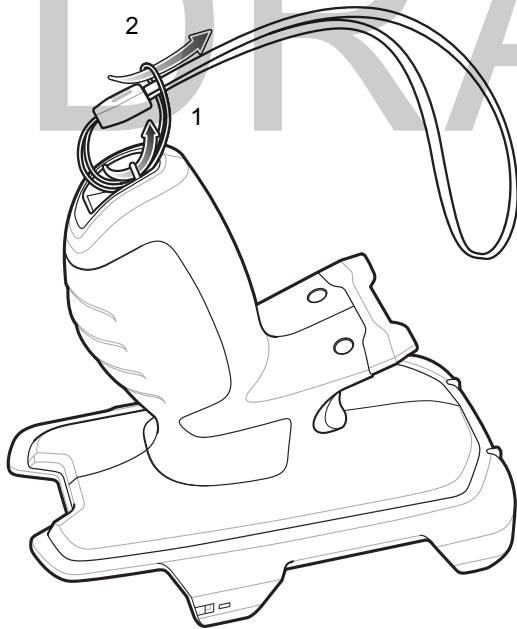

Inserting the Device into the Trigger Handle

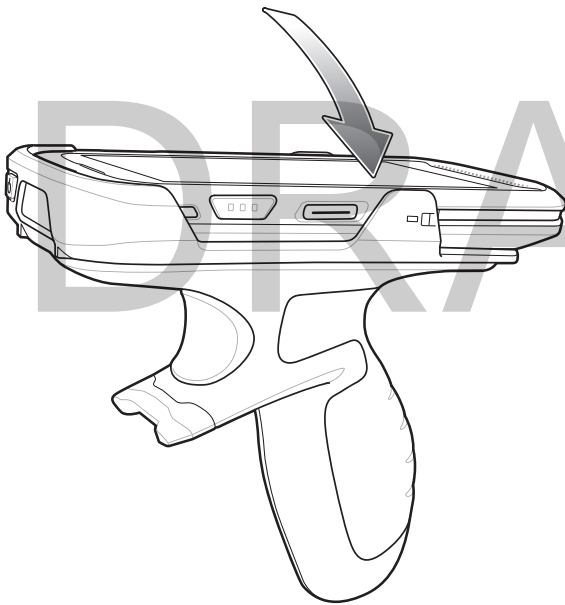
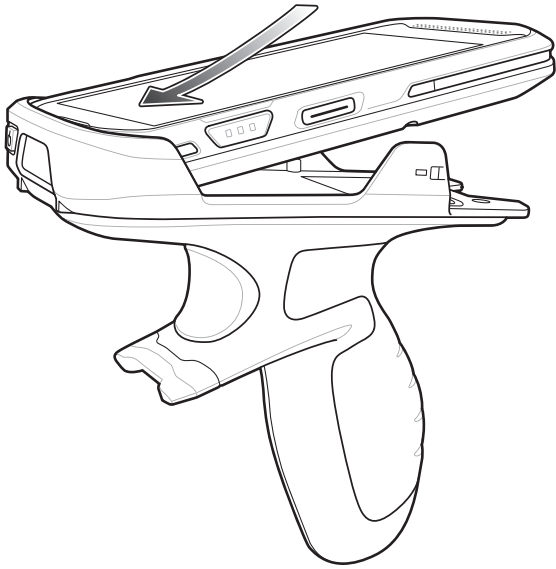

DRAFT 1

Removing the Device from the Trigger Handle

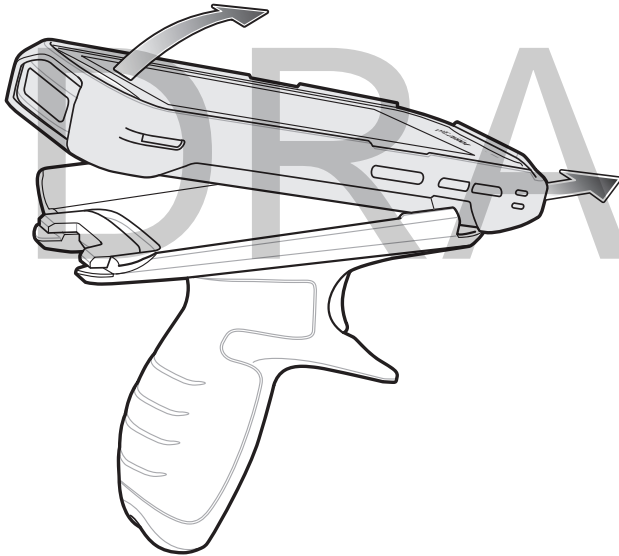

Scanning

To read a bar code, a scan-enabled application is required. The TC25 contains the DataWedge application that allows the user to enable the imager, decode the bar code data and display the bar code content.

1. Ensure that an application is open on the TC25 and a text field is in focus (text cursor in text field).
2. Point the exit window on the top of the TC25 at a bar code.

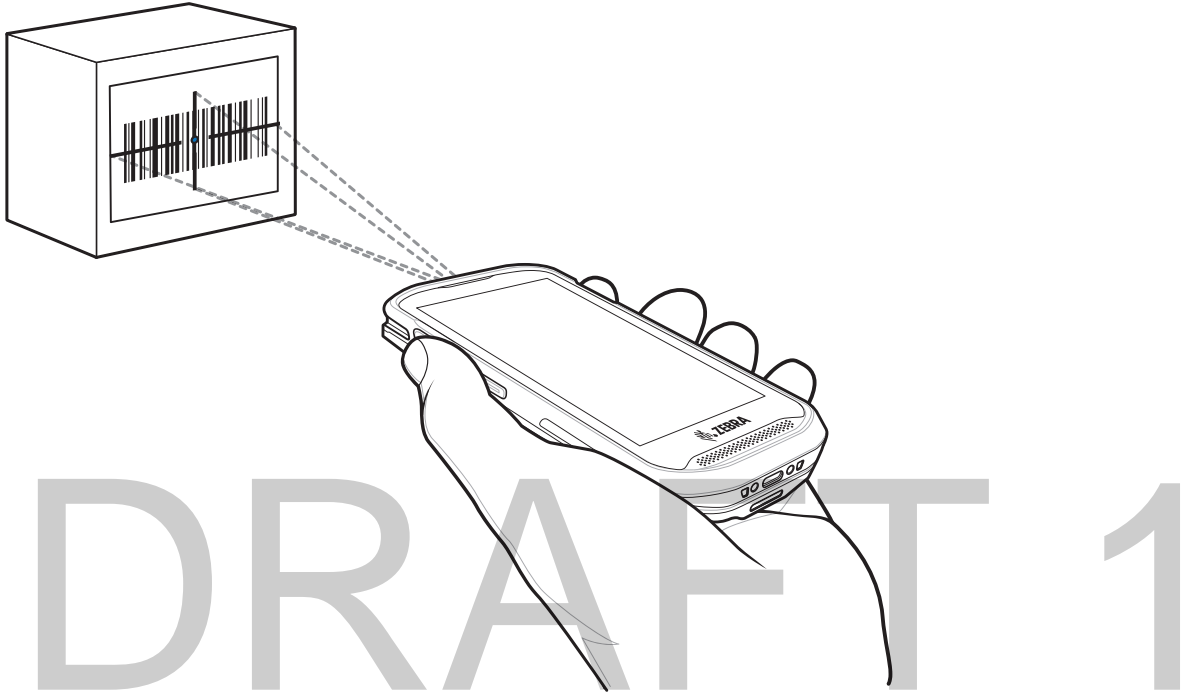

3. Press and hold the scan button.
The red laser aiming pattern turns on to assist in aiming.



NOTE When the TC25 is in Picklist mode, the imager does not decode the bar code until the crosshair or aiming dot touches the bar code.

4. Ensure the bar code is within the area formed by the crosshairs in the aiming pattern. The aiming dot is used for increased visibility in bright lighting conditions.

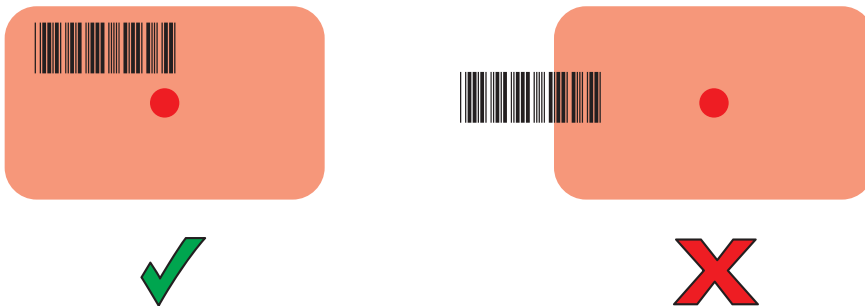

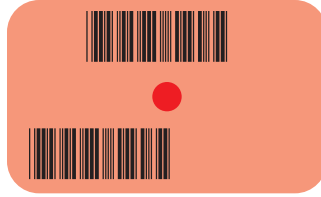
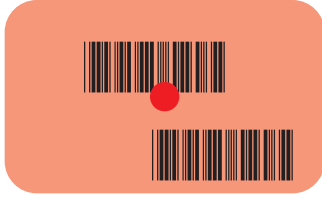

5. The Data Capture LED lights green and a beep sounds, by default, to indicate the bar code was decoded successfully.
6. Release the scan button.



NOTE Imager decoding usually occurs instantaneously. The TC25 repeats the steps required to take a digital picture (image) of a poor or difficult bar code as long as the scan button remains pressed.

7. The bar code content data displays in the text field.

Ergonomics Recommendations

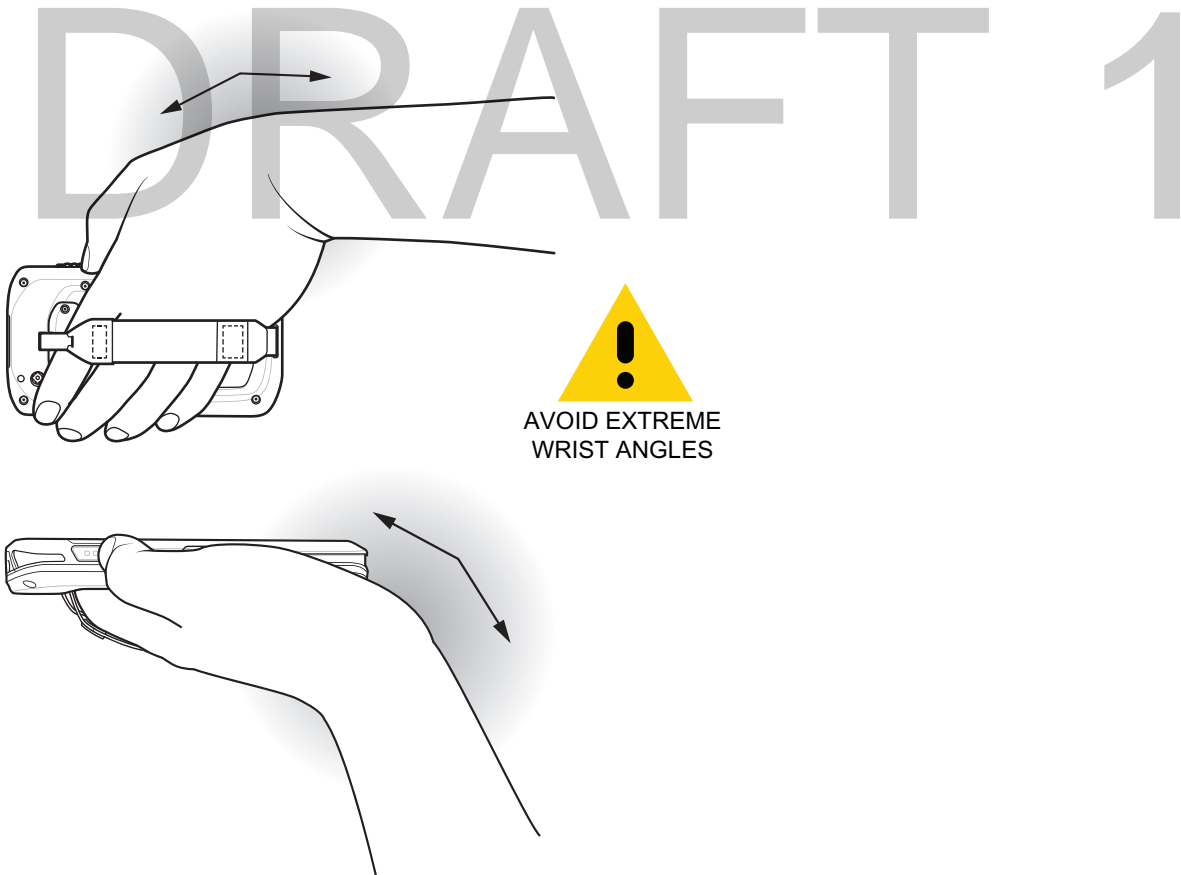

DRAFT 1

DRAFT 1