

ZM™ Series/RZ™ Series

Industrial/Commercial Printer

User Guide



© 2008 ZIH Corp. The copyrights in this manual and the software and/or firmware in the printer described therein are owned by ZIH Corp. Unauthorized reproduction of this manual or the software and/or firmware in the printer may result in imprisonment of up to one year and fines of up to \$10,000 (17 U.S.C.506). Copyright violators may be subject to civil liability.

This product may contain ZPL®, ZPL II®, and ZebraLink™ programs; Element Energy Equalizer® Circuit; E³®, and Monotype Imaging fonts. Software © ZIH Corp. All rights reserved worldwide.

ZebraLink and all product names and numbers are trademarks, and Zebra, the Zebra logo, ZPL, ZPL II, Element Energy Equalizer Circuit, and E³ Circuit are registered trademarks of ZIH Corp. All rights reserved worldwide.

All other brand names, product names, or trademarks belong to their respective holders. For additional trademark information, please see "Trademarks" on the product CD.

Proprietary Statement This manual contains proprietary information of Zebra Corporation and its subsidiaries ("Zebra Technologies"). It is intended solely for the information and use of parties operating and maintaining the equipment described herein. Such proprietary information may not be used, reproduced, or disclosed to any other parties for any other purpose without the express, written permission of Zebra Technologies Corporation.

Product Improvements Continuous improvement of products is a policy of Zebra Technologies Corporation. All specifications and designs are subject to change without notice.

Liability Disclaimer Zebra Technologies Corporation takes steps to ensure that its published Engineering specifications and manuals are correct; however, errors do occur. Zebra Technologies Corporation reserves the right to correct any such errors and disclaims liability resulting therefrom.

Limitation of Liability In no event shall Zebra Technologies Corporation or anyone else involved in the creation, production, or delivery of the accompanying product (including hardware and software) be liable for any damages whatsoever (including, without limitation, consequential damages including loss of business profits, business interruption, or loss of business information) arising out of the use of, the results of use of, or inability to use such product, even if Zebra Technologies Corporation has been advised of the possibility of such damages. Some jurisdictions do not allow the exclusion or limitation of incidental or consequential damages, so the above limitation or exclusion may not apply to you.

Part Number: 79695L-002 Rev. A



Declaration of Conformity

I have determined that the Zebra printers identified as the

ZM™ Series

Z4M, Z6M, Z4Mplus, Z6Mplus, R4Mplus, ZM400, ZM600

manufactured by:

Zebra Technologies Corporation
333 Corporate Woods Parkway
Vernon Hills, Illinois 60061-3109 U.S.A.

Have been shown to comply with the applicable technical standards of the FCC

For Home, Office, Commercial, and Industrial use

If no unauthorized change is made in the equipment,
and if the equipment is properly maintained and operated.

A handwritten signature in black ink, appearing to read "M. Charles T. Jones".

Compliance Information

FCC Compliance Statement

This device complies with Part 15 rules. Operation is subject to the following two conditions:

1. This device may not cause harmful interference, and
2. This device must accept any interference received, including interference that may cause undesired operation.

The user is cautioned that any changes or modifications not expressly approved by Zebra Technologies could void the user's authority to operate the equipment. To ensure compliance, this printer must be used with Shielded Communication Cables.

FCC Radiation Exposure Statement (for printers with RFID encoders)

This equipment complies with FCC radiation exposure limits set forth for an uncontrolled environment. This equipment should be installed and operated with minimum distance 20cm between the radiator and your body.

This transmitter must not be co-located or operating in conjunction with any other antenna or transmitter.

Canadian DOC Compliance Statement

This Class B digital apparatus complies with Canadian ICES-003.

Cet appareil numérique de la classe B est conforme à la norme NMB-003 du Canada.

Contents



Declaration of Conformity	3
Compliance Information	4
About This Document	9
Who Should Use This Document	10
How This Document Is Organized	10
Contacts	11
Web Site	11
The Americas	11
Europe, Africa, Middle East, and India	11
Asia Pacific	11
Document Conventions	12
1 • Introduction	15
External View	16
Printer Media Compartment	17
Control Panel	18
Control Panel Buttons	19
Control Panel Lights	20
Printer Language Modes	21
Firmware Downloads	21
Additional Printer Language Information	21
2 • Printer Setup	23
Before You Begin	24
Handling the Printer	25
Unpack and Inspect the Printer	25
Store the Printer	25
Ship the Printer	25

6 | Contents

Select a Site for the Printer	26
Select a Surface	26
Provide Proper Operating Conditions	26
Allow Proper Space	26
Provide a Data Source	26
Provide a Power Source	26
Select a Data Communication Interface	27
Data Cables and Wireless Cards	28
Connect the Printer to the Computer or Network	28
Connect the Printer to a Power Source	31
Power Cord Specifications	32
Types of Media	33
Ribbon Overview	35
When to Use Ribbon	35
Coated Side of Ribbon	35
3 • Operations	37
Print Modes and Printer Options	38
Print Mode Descriptions and Printer Requirements	38
Media Paths	39
Load Media	41
Beginning Steps for all Print Modes and Printer Options	41
Additional Steps for Tear-Off Mode	44
Additional Steps for Peel-Off Mode (with or without Liner Take-Up)	45
Additional Steps for Cutter or Delayed Cut Mode	50
Additional Steps for Rewind Mode	51
Load Ribbon	55
Remove Used Ribbon	59
Calibrate the Printer	60
Auto Calibration	60
Manual Calibration	60
Adjust Printhead Pressure	61
4 • Configuration	63
Setup Mode	64
Enter Setup Mode	64
Exit Setup Mode	65
Change Password-Protected Parameters	66
Default Password Value	66
Disable the Password Protection Feature	66
Print a Configuration Label	67
Print a Network Configuration Label	68

- Control Panel Parameters 69
 - How to View or Modify Parameters 69
 - Additional Parameters 69
 - Standard Printer Parameters 70
- 5 • Routine Maintenance 97**
 - Replacing Printer Components 98
 - Ordering Replacement Parts 98
 - Recycling Printer Components 98
 - Lubrication 98
 - Cleaning Schedule and Procedures 99
 - Clean the Exterior 99
 - Clean the Printhead and Platen Roller 100
 - Clean the Media Compartment and Sensors 103
 - Clean the Cutter Module 104
 - Routine Maintenance for the Rewind Option 106
 - Remove Printed Labels or Liner from the Rewind Spindle 106
 - Adjust Media Alignment for Rewind Option 108
- 6 • Troubleshooting 109**
 - Troubleshooting Checklists 110
 - LCD Error Messages 111
 - Print Quality Problems 115
 - Calibration Problems 118
 - Communications Problems 119
 - Ribbon Problems 120
 - Miscellaneous Printer Problems 121
 - Printer Diagnostics 123
 - Power-On Self Test 123
 - CANCEL Self Test 124
 - PAUSE Self Test 125
 - FEED Self Test 126
 - FEED and PAUSE Self Test 129
 - Communications Diagnostics Test 130
 - Sensor Profile 131
- 7 • Specifications 133**
 - General Specifications 134
 - Printing Specifications 135
 - Media Specifications 137
 - Ribbon Specifications 138
 - Printer Options 139
- Index 141**



Notes • _____

About This Document



This section provides you with contact information, document structure and organization, and additional reference documents.

Contents

Who Should Use This Document	10
How This Document Is Organized	10
Contacts	11
Document Conventions	12

10 | About This Document Who Should Use This Document

Who Should Use This Document

This User Guide is intended for use by any person who needs to operate or to troubleshoot problems with the printer.

How This Document Is Organized

The User Guide is set up as follows:

Section	Description
Introduction on page 15	This section shows the operational controls and location of major components used when loading media.
Printer Setup on page 23	This section provides the tasks that you must complete and the issues that you must consider before you load and configure your printer.
Operations on page 37	This section provides the procedures for loading and calibrating the printer.
Configuration on page 63	This section describes the control panel parameters that are used to configure the printer for operation.
Routine Maintenance on page 97	This section provides routine cleaning and maintenance procedures.
Troubleshooting on page 109	This section provides information about errors that you might need to troubleshoot. Assorted diagnostic tests are included.
Specifications on page 133	This section provides the features of and specifications for the printer.

Contacts

You can contact Zebra Technologies Corporation at the following:

Web Site

<http://www.zebra.com>

Technical Support via the Internet is available 24 hours per day, 365 days per year. Go to <http://www.zebra.com/support>.

The Americas

Regional Headquarters	Technical Support	Customer Service Dept.
Zebra Technologies International, LLC 333 Corporate Woods Parkway Vernon Hills, Illinois 60061.3109 U.S.A T: +1 847 793 2600 Toll-free +1 800 423 0422 F: +1 847 913 8766	T: +1 877 ASK ZEBRA (275 9327) F: +1 847 913 2578 Hardware: ts1@zebra.com Software: ts3@zebra.com	For printers, parts, media, and ribbon, please call your distributor, or contact us. T: +1 877 ASK ZEBRA (275 9327) E: clientcare@zebra.com

Europe, Africa, Middle East, and India

Regional Headquarters	Technical Support	Internal Sales Dept.
Zebra Technologies Europe Limited Zebra House The Valley Centre, Gordon Road High Wycombe Buckinghamshire, HP13 6EQ, UK T: +44 (0)1494 472872 F: +44 (0) 1494 450103	T: +44 (0) 1494 768298 F: +44 (0) 1494 768210 Germany: Tsgermany@zebra.com France: Tsfrance@zebra.com Spain/Portugal: Tspain@zebra.com All other areas: Tseurope@zebra.com	For printers, parts, media, and ribbon, please call your distributor, or contact us. T: +44 (0) 1494 768316 F: +44 (0) 1494 768244 E: cseurope@zebra.com

Asia Pacific

Regional Headquarters	Technical Support	Customer Service
Zebra Technologies Asia Pacific, LLC 120 Robinson Road #06-01 Parakou Building Singapore 068913 T: +65 6858 0722 F: +65 6885 0838	T: +65 6858 0722 F: +65 6885 0838 E: China: tschina@zebra.com All other areas: tsasiapacific@zebra.com	For printers, parts, media, and ribbon, please call your distributor, or contact us. T: +65 6858 0722 F: +65 6885 0836

Document Conventions

The following conventions are used throughout this document to convey certain information.

Alternate Color (online only) Cross-references contain hot links to other sections in this guide. If you are viewing this guide online in .pdf format, you can click the cross-reference (blue text) to jump directly to its location.

LCD Display Examples Text from a printer's Liquid Crystal Display (LCD) appears in **Bubbledot ICG** font.

Command Line Examples Command line examples appear in *Courier New* font. For example, type ZTools to get to the Post-Install scripts in the bin directory.

Files and Directories File names and directories appear in *Courier New* font. For example, the Zebra<version number>.tar file and the /root directory.

Icons Used



Caution • Warns you of the potential for electrostatic discharge.



Caution • Warns you of a potential electric shock situation.



Caution • Warns you of a situation where excessive heat could cause a burn.



Caution • Advises you that failure to take or avoid a specific action could result in physical harm to you.

Caution • (No icon) Advises you that failure to take or avoid a specific action could result in physical harm to the hardware.



Important • Advises you of information that is essential to complete a task.



Note • Indicates neutral or positive information that emphasizes or supplements important points of the main text.



Example • Provides an example, often a scenario, to better clarify a section of text.

Illustration Callouts Callouts are used when an illustration contains information that needs to be labeled and described. A table that contains the labels and descriptions follows the graphic. [Figure 1](#) provides an example.

Figure 1 • Sample Figure with Callouts

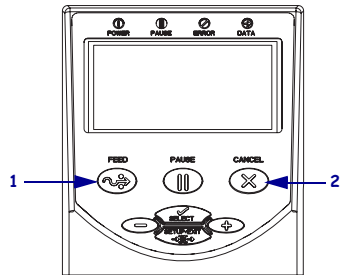

1	FEED button
2	CANCEL button



Notes • _____

1

Introduction



This section shows the operational controls and location of major components used when loading media.

Contents

External View	16
Printer Media Compartment	17
Control Panel	18
Control Panel Buttons	19
Control Panel Lights	20
Printer Language Modes	21

External View

Figure 2 and Figure 3 show the components and connections on the outside of the printer.

Figure 2 • Front of Printer

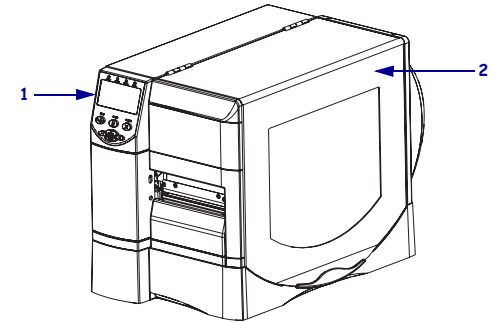

1	Control panel
2	Media door

Figure 3 • Rear of Printer

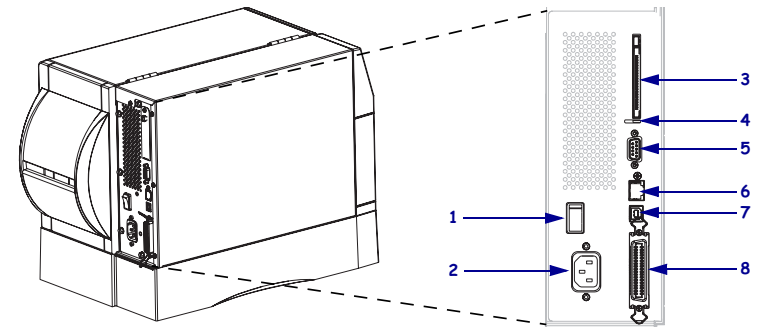

1	Power switch (O = off, I = on)	5	Serial port
2	AC power connector	6	Internal wired print server port (Ethernet)
3	Wireless print server card slot (Ethernet)	7	USB port
4	Wireless card ejector button	8	Parallel port

Printer Media Compartment

Figure 4 shows the components inside the media compartment of your printer. Depending on installed options, your printer may look slightly different.



Note • For optimal printing quality and proper printer performance across our product line, Zebra strongly recommends the use of genuine Zebra™ supplies as part of the total solution. Specifically, the ZM400, ZM600, RM400, and RM600 are designed to work only with genuine Zebra™ printheads, thus maximizing safety and print quality.

Figure 4 • Printer Components

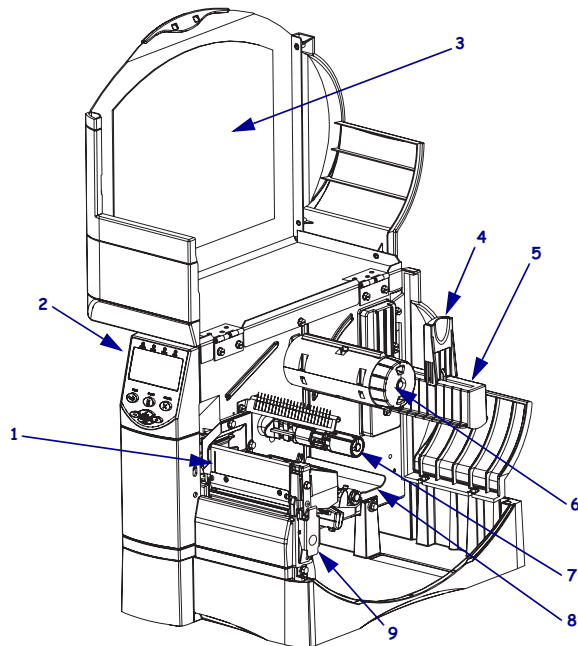

1	Printhead assembly	6	Ribbon take-up spindle
2	Control panel	7	Ribbon supply spindle
3	Media door	8	Dancer assembly
4	Media supply guide	9	Printhead release latch
5	Media supply hanger		

Control Panel

The control panel contains the lights that indicate basic operation and the buttons that you may need to press during basic operation. The control panel buttons and lights are labeled in Figure 5. Descriptions for each are located in Table 1 and Table 2.

Figure 5 • Control Panel

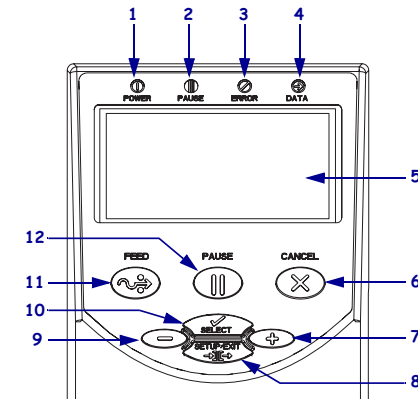

1	Power LED
2	Pause LED
3	Error LED
4	Data LED
5	LCD
6	CANCEL button
7	PLUS (+) button
8	SETUP/EXIT button
9	MINUS (-) button
10	SELECT button
11	FEED button
12	PAUSE button

Control Panel Buttons

Table 1 • Control Panel Buttons

Button	Function
FEED	Forces the printer to feed one blank label each time the button is pressed. <ul style="list-style-type: none"> Printer not printing: one blank label immediately feeds. Printing: one blank label feeds after the current batch of labels is complete.
PAUSE	Starts and stops the printing process. <ul style="list-style-type: none"> Printer not printing: no printing occurs. (Press PAUSE again to resume printing.) Printing: printing stops after the current label is complete.
CANCEL	Cancels print jobs when the printer is paused. <ul style="list-style-type: none"> Printer not printing: the next stored label format does not print. Printing: current label completes printing, and the next label format is cancelled. Press and hold for several seconds to cancel all print jobs in memory.
SETUP/EXIT	Enters and exits the configuration mode.
SELECT	Toggles the function of PLUS (+) and MINUS (-) between the Scroll and Change Modes. <ul style="list-style-type: none"> Press once to use PLUS (+) and MINUS (-) to change the values of the selection. Press again to use PLUS (+) and MINUS (-) to scroll through the menu items.
PLUS (+) (scroll mode)	Scrolls to the next selection.
PLUS (+) (change mode)	<ul style="list-style-type: none"> Increases the value. Performs the action on the bottom right of the LCD.
MINUS (-) (scroll mode)	Scrolls to the previous selection.
MINUS (-) (change mode)	<ul style="list-style-type: none"> Decreases the value. Moves to the next available digit in a number. Performs the action on the bottom left of the LCD.

Control Panel Lights

Table 2 • Control Panel Lights

Light	Status	Indication
POWER	Off	The printer is off, or no power is applied.
	On	The printer is on.
PAUSE	Off	Normal printer operation.
	On	The printer has stopped all printing operations.
	Flashing	The Pause light flashes when initializing FLASH memory and in Peel-Off Mode when the label is available.
ERROR	Off	Normal printer operation (no errors).
	On	An error condition is preventing printing. This includes MEDIA OUT and RIBBON OUT errors.
	Flashing	An error condition exists, but printing is allowed to continue. This includes RIBBON IN warning, HEAD UNDER TEMP warning, and HEAD OVER TEMP error.
DATA	Off	Normal printer operation (no data being received or processed).
	One flash	CANCEL was pressed and a format is successfully cancelled.
	Slow flashing	The printer cannot accept more data from the host.
	Fast flashing	The printer is receiving data.
	On	A partial format has been received and no subsequent data activity.

Printer Language Modes

Depending on how your printer was ordered, it came from the factory with firmware that operates in or allows you to use certain commands for one of the following printer languages:

- Zebra Programming Language (ZPL[®])
- Eltron[®] Programming Language (EPL[™])

Firmware Downloads

You may download firmware to the printer at any time to change from one printer language to another. For the latest firmware versions and instructions for downloading them, go to <http://www.zebra.com/firmware>.



Note • When the printer changes from one printer language to another, error messages may appear on the LCD, and some control panel lights may activate in error mode. You may ignore these error messages and lights. When the firmware download is complete, reboot the printer and then load printer defaults to return the printer to Operating mode.

Additional Printer Language Information

The following manuals contain specific information about the different printer language modes. Copies of these manuals are on the CD that came with your printer and at <http://www.zebra.com/manuals>.

- ZPL II[®] Programming Guide
- EPL2[™] Programming Guide



Notes • _____

2



Printer Setup

This section provides the tasks that you must complete and the issues that you must consider before you load and configure your printer.

Contents

Before You Begin	24
Handling the Printer	25
Unpack and Inspect the Printer	25
Store the Printer	25
Ship the Printer	25
Select a Site for the Printer	26
Select a Surface	26
Provide Proper Operating Conditions	26
Allow Proper Space	26
Provide a Data Source	26
Provide a Power Source	26
Select a Data Communication Interface	27
Data Cables and Wireless Cards	28
Connect the Printer to the Computer or Network	28
Connect the Printer to a Power Source	31
Power Cord Specifications	32
Types of Media	33
Ribbon Overview	35
When to Use Ribbon	35
Coated Side of Ribbon	35

Before You Begin

Review this checklist, and resolve any issues before you set up or use your printer.

- ❑ **Unpack and Inspect the Printer** Have you unpacked the printer and inspected it for damage? If you have not, see [Unpack and Inspect the Printer on page 25](#).
- ❑ **Select a Site** Have you selected an appropriate location for the printer? If you have not, see [Select a Site for the Printer on page 26](#).
- ❑ **Connect to a Data Source** Have you determined how the printer will connect to a data source (usually a computer)? For more information, see [Select a Data Communication Interface on page 27](#).
- ❑ **Attach a Power Cord** Do you have the correct power cord for your printer? If you are unsure, see [Power Cord Specifications on page 32](#). To attach the power cord and connect the printer to a power source, see [Connect the Printer to a Power Source on page 31](#).
- ❑ **Select Media** Do you have the correct media for your application? If you are unsure, see [Types of Media on page 33](#).
- ❑ **Select Ribbon** Do you need to use ribbon, and is the appropriate ribbon available, if needed? If you are unsure, see [Ribbon Overview on page 35](#).

Handling the Printer

This section describes how to handle your printer.

Unpack and Inspect the Printer

When you receive the printer, immediately unpack it and inspect for shipping damage.

- Save all packing materials.
- Check all exterior surfaces for damage.
- Raise the media door, and inspect the media compartment for damage to components.

If you discover shipping damage upon inspection:

- Immediately notify the shipping company and file a damage report.
- Keep all packaging material for shipping company inspection.
- Notify your authorized Zebra reseller



Important • Zebra Technologies Corporation is not responsible for any damage incurred during the shipment of the equipment and will not repair this damage under warranty.

Store the Printer

If you are not placing the printer into immediate operation, repackage it using the original packing materials. You may store the printer under the conditions shown in [Table 3](#).

Table 3 • Storage Temperature and Humidity

Temperature	Relative Humidity
-40°F to 140°F (-40° to 60°C)	5% to 85% non-condensing

Ship the Printer

If you must ship the printer:

- Turn off (O) the printer, and disconnect all cables.
- Remove any media, ribbon, or loose objects from the printer interior.
- Close the printhead.
- Carefully pack the printer into the original container or a suitable alternate container to avoid damage during transit. A shipping container can be purchased from Zebra if the original packaging has been lost or destroyed.

Select a Site for the Printer

Consider the following when selecting an appropriate location for your printer.

Select a Surface

Select a solid, level surface of sufficient size and strength to accommodate the printer and other equipment (such as a computer), if necessary. The choices include a table, countertop, desk, or cart. For the printer's weight and dimensions, see [General Specifications on page 134](#).

Provide Proper Operating Conditions

This printer is designed to function in a wide range of environmental and electrical conditions, including a warehouse or factory floor. For more information on the required conditions, see [General Specifications on page 134](#).

[Table 4](#) shows the temperature and relative humidity requirements for the printer when it is operating.

Table 4 • Operating Temperature and Humidity

Mode	Temperature	Relative Humidity
Thermal Transfer	40° to 104°F (5° to 40°C)	20 to 85% non-condensing.
Direct Thermal	32° to 104°F (0° to 40°C)	20 to 85% non-condensing

Allow Proper Space

The printer should have enough space around it for you to be able to open the media door. To allow for proper ventilation and cooling, leave open space on all sides of the printer.



Caution • Do not place any padding or cushioning material behind or under the printer because this restricts air flow and could cause the printer to overheat.

Provide a Data Source

If the printer will be located away from the data source (such as a computer), the selected site must provide the appropriate connections to that data source. For more information on the types of communication interfaces and their limitations, see [Select a Data Communication Interface on page 27](#).

Provide a Power Source

Place the printer within a short distance of a power outlet that is easily accessible.

Select a Data Communication Interface

Table 5 provides basic information about data communication interfaces that you can use to connect your printer to a computer. You may send label formats to the printer through any data communication interface that is available. Select an interface that is supported by both your printer and your computer or your Local Area Network (LAN).

Table 5 • Characteristics of the Data Communication Interfaces

Interface	Standard or Optional on Printer	Characteristics
RS-232 Serial	Standard	<ul style="list-style-type: none"> Maximum cable length of 50 ft (15.24 m). You may need to change printer parameters to match the host computer. You need to use a null-modem adaptor to connect to the printer if using a standard modem cable.
IEEE 1284 Bidirectional Parallel	Standard	<ul style="list-style-type: none"> Maximum cable length of 10 ft (3 m). Recommended cable length of 6 ft (1.83 m). No printer parameter changes required to match the host computer.
USB	Standard	<ul style="list-style-type: none"> Maximum cable length of 16.4 ft (5 m). No printer parameter changes required to match the host computer.
Internal wired Ethernet print server	Optional	<ul style="list-style-type: none"> Can print to the printer from any computer on your LAN. Can communicate with the printer through the printer's web pages. Computer must be equipped with an Ethernet board. The printer must be configured to use your LAN.
Wireless Ethernet print server	Optional	<ul style="list-style-type: none"> Can print to the printer from any computer on your Wireless Local Area Network (WLAN). Can communicate with the printer through the printer's web pages. Computer must be equipped with an Ethernet board. The printer must be configured to use your WLAN.

Data Cables and Wireless Cards

You must supply all data cables or wireless cards for your application.

Data Cables Ethernet cables do not require shielding, but all other data cables must be fully shielded and fitted with metal or metallized connector shells. Unshielded data cables may increase radiated emissions above the regulated limits.

To minimize electrical noise pickup in the cable:

- Keep data cables as short as possible.
- Do not bundle the data cables tightly with the power cords.
- Do not tie the data cables to power wire conduits.

Wireless Cards For supported wireless cards, refer to the ZebraNet Wireless Print Server and Wireless Plus Print Server User Guide. A copy of the manual is available at <http://www.zebra.com/manuals> or on the user CD that came with your printer.

Connect the Printer to the Computer or Network

Table 6 shows how to connect the different types of data cables to your printer and computer. The connectors on the back of your computer may be in different locations than on the sample computer shown in this section. For another view of the connectors on the printer, see Figure 3 on page 16.

Caution • Ensure that the printer power is off (O) before connecting data communications cables. Connecting a data communications cable while the power is on (I) may damage the printer.

Table 6 • Connecting the Printer to a Computer or Network

Interface	Connection and Configuration
RS-232 Serial	<p>The baud rate, number of data and stop bits, the parity, and the XON/XOFF or DTR control must match those of the host computer. See Control Panel Parameters on page 69 to view or change these parameters.</p> 

Table 6 • Connecting the Printer to a Computer or Network (Continued)

Interface	Connection and Configuration
IEEE 1284 Bidirectional Parallel	<p>No additional configuration is necessary.</p> 
USB	<p>No additional configuration is necessary.</p> <p>Caution • Be careful not to plug the USB cable into the wired Ethernet print server connector on the printer because doing so will damage the connector.</p> 

Table 6 • Connecting the Printer to a Computer or Network (Continued)

Interface	Connection and Configuration
Internal wired Ethernet print server	<p>Refer to the ZebraNet 10/100 Print Server User and Reference Guide for configuration instructions. A copy of this manual is available at http://www.zebra.com/manuals or on the user CD that came with your printer.</p> 
Wireless Ethernet print server	<p>Refer to the ZebraNet Wireless Print Server and Wireless Plus Print Server User Guide for configuration instructions. A copy of this manual is available at http://www.zebra.com/manuals or on the user CD that came with your printer.</p>

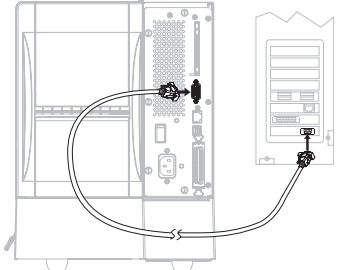
Connect the Printer to a Power Source

The AC power cord must have a three-prong female connector on one end that plugs into the mating AC power connector at the rear of the printer. If a power cable was not included with your printer, refer to [Power Cord Specifications on page 32](#).

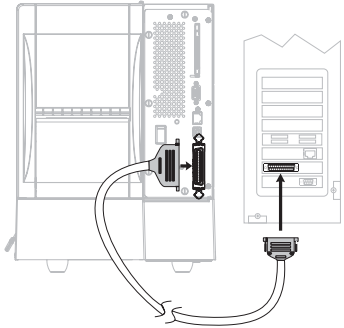
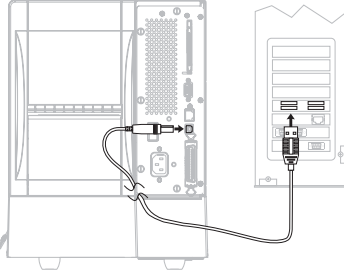
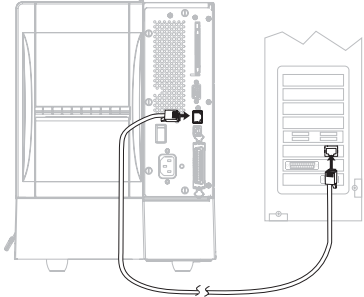

Caution • For personnel and equipment safety, always use an approved three-conductor power cord specific to the region or country intended for installation. This cord must use an IEC 320 female connector and the appropriate region-specific three-conductor grounded plug configuration.

To connect the printer to a power source, complete these steps:

1. Toggle the printer power switch to the off (O) position.
2. Plug the power cord into the AC power connector (1) on the rear of the printer.

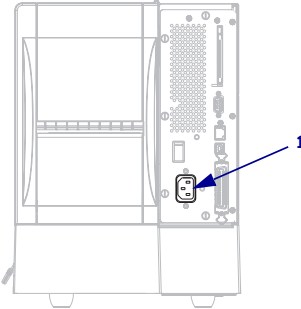

3. Plug the other end of the power cord into a power outlet near the printer.
4. Turn on (I) the printer.

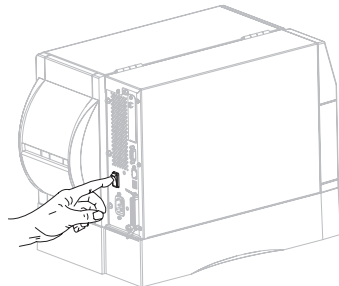

The control panel LCD and lights activate, indicating that the printer is booting up.

Power Cord Specifications



Caution • For personnel and equipment safety, always use an approved three-conductor power cord specific to the region or country intended for installation. This cord must use an IEC 320 female connector and the appropriate region-specific, three-conductor grounded plug configuration.

Depending on how your printer was ordered, a power cord may or may not be included. If one is not included or if the one included is not suitable for your requirements, see [Figure 6](#) and refer to the following guidelines:

- The overall cord length must be less than 9.8 ft. (3 m).
- The cord must be rated for at least 10 A, 250 V.
- The chassis ground (earth) must be connected to ensure safety and reduce electromagnetic interference.

Figure 6 • Power Cord Specifications

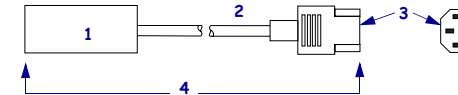

1	AC power plug for your country—This should bear the certification mark of at least one of the known international safety organizations (Figure 7).
2	3-conductor HAR cable or other cable approved for your country.
3	IEC 320 connector—This should bear the certification mark of at least one of the known international safety organizations (Figure 7).
4	Length ≤ 9.8 ft. (3 m). Rating 10 Amp, 250 VAC.

Figure 7 • International Safety Organization Certifications



Types of Media



Important • Zebra strongly recommends the use of Zebra-brand supplies for continuous high-quality printing. A wide range of paper, polypropylene, polyester, and vinyl stock has been specifically engineered to enhance the printing capabilities of the printer and to prevent premature printhead wear. To purchase supplies, go to <http://www.zebra.com/howtobuy>.

Your printer can use various types of media:

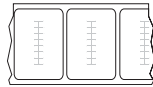

- Standard media—Most standard media uses an adhesive backing that sticks individual labels or a continuous length of labels to a liner.
- Tag stock—Tags are usually made from a heavy paper. Tag stock does not have adhesive or a liner, and it is typically perforated between tags.
- Radio frequency identification (RFID) “smart” media—RFID media can be used in a printer that is equipped with an RFID reader/encoder. RFID labels are made from the same materials and adhesives as non-RFID labels. Each label has an RFID transponder (sometimes called an “inlay”), made of a chip and an antenna, embedded between the label and the liner. The shape of the transponder varies by manufacturer and is visible through the label. All “smart” labels have memory that can be read, and many have memory that can be encoded.



Important • Transponder placement within a label depends on the transponder type and the printer model. Make sure that you are using the correct “smart” media for your printer.

Table 7 describes roll and fanfold media. Roll media is loaded into the printer while fanfold media may be located inside or outside of the printer.

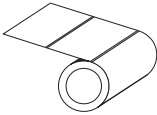
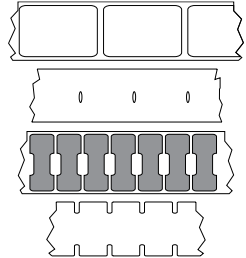
Table 7 • Roll and Fanfold Media

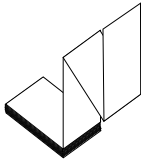
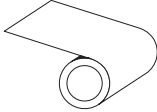
Media Type	How It Looks	Description
Non-Continuous Roll Media		<p>Roll media is wound on a 3-in. (76-mm) core. Individual labels are separated by one or more of the following methods:</p> <ul style="list-style-type: none"> • Web media separates labels by gaps, holes, or notches.  <ul style="list-style-type: none"> • Black mark media uses pre-printed black marks on the back side of the media to indicate label separations.  <ul style="list-style-type: none"> • Perforated media has perforations that allow the labels or tags to be separated from each other easily. The media may also have black marks or other separations between labels or tags. 
Non-Continuous Fanfold Media		<p>Fanfold media is folded in a zigzag pattern. Fanfold media can have the same label separations as non-continuous roll media. The separations would fall on or near the folds.</p>
Continuous Roll Media		<p>Roll media is wound on a 3-in. (76-mm) core. Continuous roll media does not have gaps, holes, notches, or black marks to indicate label separations. This allows the image to be printed anywhere on the label. Sometimes a cutter is used to cut apart individual labels.</p>

Ribbon Overview

Ribbon is a thin film that is coated on one side with wax, resin, or wax resin, which is transferred to the media during the thermal transfer process. The media determines whether you need to use ribbon and how wide the ribbon must be.

When ribbon is used, it must be as wide as or wider than the media being used. If the ribbon is narrower than the media, areas of the printhead are unprotected and subject to premature wear.

When to Use Ribbon

Thermal transfer media requires ribbon for printing while direct thermal media does not. To determine if ribbon must be used with a particular media, perform a media scratch test.

To perform a media scratch test, complete these steps:

1. Scratch the print surface of the media rapidly with your fingernail.
2. Did a black mark appear on the media?

If a black mark...	Then the media is...
Does not appear on the media	Thermal transfer. A ribbon is required.
Appears on the media	Direct thermal. No ribbon is required.

Coated Side of Ribbon

Ribbon can be wound with the coated side on the inside or outside. The ribbon used must match the Thermal Transfer option installed. The standard Thermal Transfer option (black ribbon spindle) uses ribbon coated on the outside, and the alternate Thermal Transfer option (gray ribbon spindle) uses ribbon coated on the inside. If you are unsure which side of a particular roll of ribbon is coated, perform an adhesive test or a ribbon scratch test to determine which side is coated.



Adhesive Test

If you have labels available, perform the adhesive test to determine which side of a ribbon is coated. This method works well for ribbon that is already installed.

To perform an adhesive test, complete these steps:

1. Peel a label from its liner.
2. Press a corner of the sticky side of the label to the outer surface of the roll of ribbon.
3. Peel the label off of the ribbon.

4. Observe the results. Did flakes or particles of ink from the ribbon adhere to the label?

If ink from the ribbon...	Then...
Adhered to the label	The ribbon is coated on the outside and can be used with the standard Thermal Transfer option (black ribbon spindle). In the ribbon loading procedure, instructions are marked with this symbol. 
Did not adhere to the label	The ribbon is coated on the inside and can be used with the alternate Thermal Transfer option (gray ribbon spindle). In the ribbon loading procedure, instructions are marked with this symbol. 

Ribbon Scratch Test

Perform the ribbon scratch test when labels are unavailable.

To perform a ribbon scratch test, complete these steps:

1. Unroll a short length of ribbon.
2. Place the unrolled section of ribbon on a piece of paper with the outer surface of the ribbon in contact with the paper.
3. Scratch the inner surface of the unrolled ribbon with your fingernail.
4. Lift the ribbon from the paper.
5. Observe the results. Did the ribbon leave a mark on the paper?

If the ribbon...	Then...
Left a mark on the paper	The ribbon is coated on the outside and can be used with the standard Thermal Transfer option (black ribbon spindle).
Did not leave a mark on the paper	The ribbon is coated on the inside and can be used with the alternate Thermal Transfer option (gray ribbon spindle). In the ribbon loading procedure, instructions are marked with this symbol. 

3

Operations



This section provides the procedures for loading and calibrating the printer.



Note • Complete the tasks and resolve the issues in [Printer Setup on page 23](#) before operating the printer.

Contents

Print Modes and Printer Options	38
Print Mode Descriptions and Printer Requirements	38
Media Paths	39
Load Media	41
Beginning Steps for all Print Modes and Printer Options	41
Additional Steps for Tear-Off Mode	44
Additional Steps for Peel-Off Mode (with or without Liner Take-Up)	45
Additional Steps for Cutter or Delayed Cut Mode	50
Additional Steps for Rewind Mode	51
Load Ribbon	55
Remove Used Ribbon	59
Calibrate the Printer	60
Auto Calibration	60
Manual Calibration	60
Adjust Printhead Pressure	61

Print Modes and Printer Options

The printer can use different print modes and options for label removal ([Table 8](#)). Use a print mode that matches the media being used and the printer options available. For more information on the types of media, see [Types of Media on page 33](#). To select a print mode, see [Select Print Mode on page 73](#).

Print Mode Descriptions and Printer Requirements

Table 8 • Print Modes and Printer Options

Print Mode	When to Use/Printer Options Required	Printer Actions
Tear-Off (default setting)	Use for most applications. This mode can be used with any printer options and most media types.	The printer prints label formats as it receives them. The printer operator can tear off the printed labels any time after they print.
Peel-Off	Use only if the printer has the Peel-Off, Liner Take-Up, or Rewind option.	The printer peels the label from the liner during printing and then pauses until the label is removed. In Peel-Off mode, the liner exits the front of the printer. In Peel-Off mode with Liner Take-Up, the liner winds onto the liner take-up spindle or the rewind spindle.
Cutter	Use if the printer has a cutter option when you want the labels to be cut apart.	The printer prints a label and then cuts it free.
Delayed Cut	Use if the printer has a cutter option when you want the printer to cut the labels apart at a signal.	The printer prints a label, pauses, and cuts the label when it receives the ~JK (delayed cut) ZPL command.
Rewind	Use if the printer has the Rewind option and you want the labels to rewind on a core.	The printer prints without pausing between labels. The media or liner is wound onto a core after printing.
Linerless Peel	Reserved for future options.	Reserved for future options.
Linerless Rewind	Reserved for future options.	Reserved for future options.

Media Paths

Table 9 shows the media paths for print mode and printer option combinations using roll media. Fanfold media uses the same print modes and printer options as roll media.

Table 9 • Media Paths for Print Modes with Various Printer Options

Print Mode	Printer Option	Media Path
Tear-Off	Printers with any printer options can use Tear-Off mode	
Peel-Off	Peel, Liner take-up, or Rewind	
Peel-Off (with Liner Take-Up)	Liner take-up	
	Rewind	

Red solid lines = media, Blue dotted lines = backing only

Table 9 • Media Paths for Print Modes with Various Printer Options (Continued)

Print Mode	Printer Option	Media Path
Cutter or Delayed Cut	Cutter (shown with an optional catch tray)	
Rewind	Rewind	

Red solid lines = media, Blue dotted lines = backing only

Load Media

The beginning steps for loading media apply to all printers, including those that have the peel-off, liner take-up, cutter, or rewind option. When you have completed these beginning steps, continue with the media loading instructions for the print mode and printer options that apply to you. For more information about print modes and printer options, see [Print Modes and Printer Options on page 38](#).

Caution • While performing any tasks near an open printhead, remove all rings, watches, hanging necklaces, identification badges, or other metallic objects that could touch the printhead. You are not required to turn off the printer power when working near an open printhead, but Zebra recommends it as a precaution. If you turn off the power, you will lose all temporary settings, such as label formats, and you must reload them before you resume printing.

Beginning Steps for all Print Modes and Printer Options

To begin loading media for all print modes and printer options, complete these steps:

1. Press the printhead release latch to open the printhead assembly. Lift the printhead until it latches open.

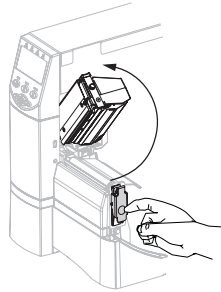

2. Slide out the media guide.

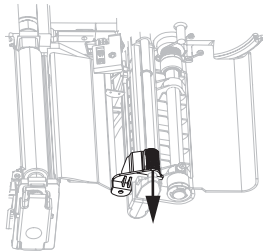

3. Insert media into the printer. Follow the instructions for roll or fanfold media, as appropriate.



Roll Media

- a. Remove and discard any tags or labels that are dirty or that are held by adhesives or tape.

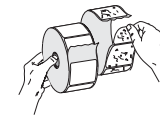

- b. Flip down the media supply guide.



- c. Place the roll of media on the media supply hanger. Push the roll as far back as it will go.

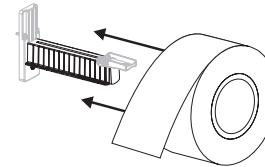

- d. Flip up the media supply guide.

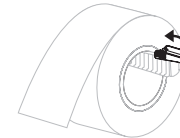

Fanfold Media

- a. Flip down the media supply guide.



- b. Feed the media through the rear or bottom access slot.

Rear Feed

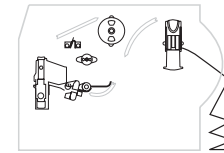

Bottom Feed

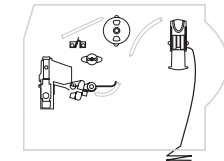

- c. Drape the media over the media supply hanger.

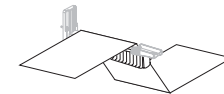

 Roll Media (Continued)

- e. Slide in the media supply guide until it touches the edge of the roll.

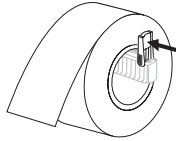

 Fanfold Media (Continued)

- d. Flip up the media supply guide.

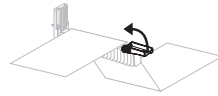

- e. Slide in the media supply guide until it touches the edge of the media.

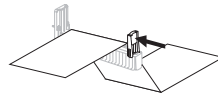

4. Feed the media under the dancer assembly (1), the upper media sensor (2), and the ribbon sensor (3). Slide the media back until it touches the inside back wall of the upper media sensor.

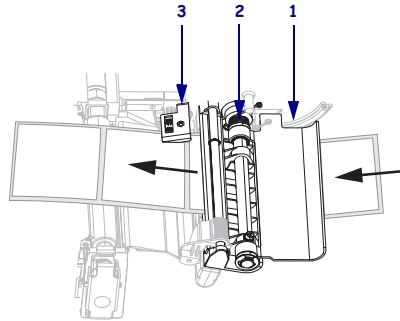

5. Continue with the final instructions for the desired print mode. The print mode must be compatible with the media being used and the printer options installed. See [Print Mode Descriptions and Printer Requirements](#) on page 38 for more information.

- [Additional Steps for Tear-Off Mode](#) on page 44
- [Additional Steps for Peel-Off Mode \(with or without Liner Take-Up\)](#) on page 45
- [Additional Steps for Cutter or Delayed Cut Mode](#) on page 50
- [Additional Steps for Rewind Mode](#) on page 51

Additional Steps for Tear-Off Mode

After completing [Beginning Steps for all Print Modes and Printer Options](#) on page 41, continue with this section to operate the printer in Tear-Off mode.

To operate the printer in Tear-Off mode, complete these steps:

1. Slide in the media guide until it touches the outer edge of the media.

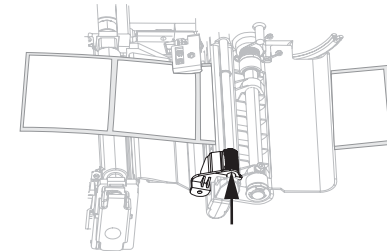

2. Set the printer to Tear-Off mode. See [Select Print Mode](#) on page 73 for instructions.
3. Close the printhead assembly.

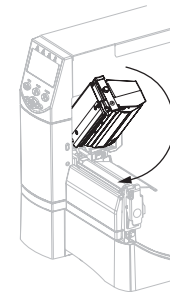

4. If the printer is paused (the Pause light is on), press PAUSE to enable printing.

Additional Steps for Peel-Off Mode (with or without Liner Take-Up)

After completing [Beginning Steps for all Print Modes and Printer Options on page 41](#), continue with this section to operate the printer in Peel-Off mode with or without liner take-up. Your printer must have the Peel option, the Liner Take-Up option, or the Rewind option installed. See [Print Modes and Printer Options on page 38](#) for more information.

For additional procedures related to the rewind option, see [Routine Maintenance for the Rewind Option on page 106](#).

To operate the printer in Peel-Off mode, complete these steps:

1. Extend the media approximately 18 in. (500 mm) out of the printer.

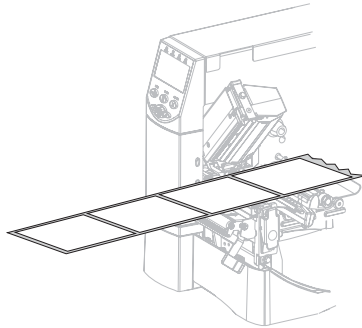

2. Remove the exposed labels so that only the liner remains.

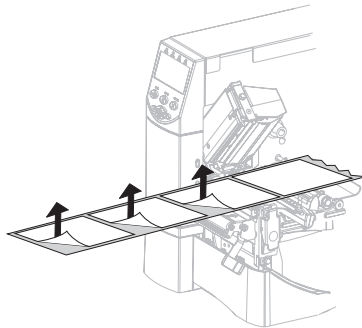

3. Push down the peel-off mechanism release lever to open the peel assembly.

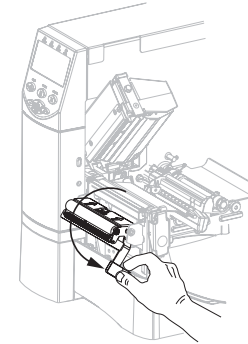

4. Feed the liner over the tear-off/peel-off bar (1) and behind the peel assembly (2). Make sure that the end of the liner falls outside of the printer.

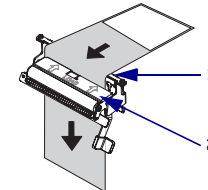

5. Complete this step only if you want to use Peel-Off mode with liner take-up. Your printer must have the Liner Take-Up option or the Rewind option installed. Follow the instructions for your printer option.

Rewind Option

- a. Feed the liner under the media alignment roller (1).

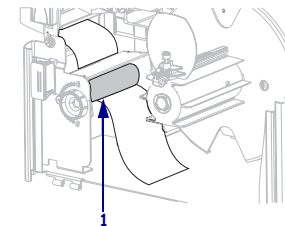

Liner Take-Up Option

- a. Slide the liner into the slot in the liner take-up spindle (1).

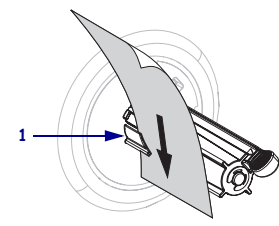

Rewind Option (Continued)

- b. Loosen the thumbscrew on the rewind media guide.

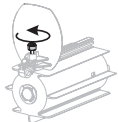

- c. Slide the rewind media guide all the way out, and then fold it down.

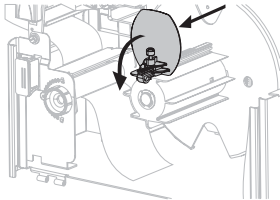

- d. Slide an empty core onto the rewind spindle.

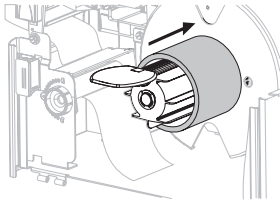

Liner Take-Up Option (Continued)

- b. Push the liner back until it touches the back plate of the liner take-up spindle assembly.

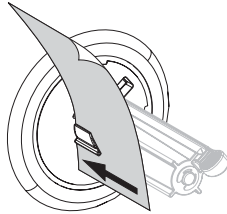

- c. Wrap the liner around the liner take-up spindle and turn the spindle counterclockwise to tighten the liner.

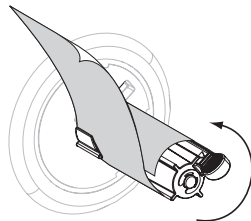

Rewind Option (Continued)

- e. Wrap the liner around the core and turn the rewind spindle counterclockwise to tighten the liner.

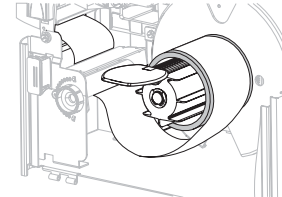

- f. Fold up the rewind media guide, and then slide it in until it touches the liner.

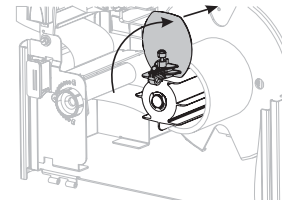

- g. Tighten the thumbscrew on the rewind media guide.

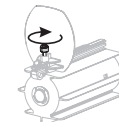

Liner Take-Up Option (Continued)

(No additional steps for the liner take-up option.)



6. **Caution** • Use the peel release lever and your right hand to close the peel assembly. Do not use your left hand to assist in closing. The top edge of the peel roller/assembly could pinch your fingers.

Close the peel assembly using the peel-off mechanism release lever.

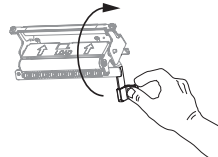

7. Slide in the media guide until it touches the outer edge of the media.

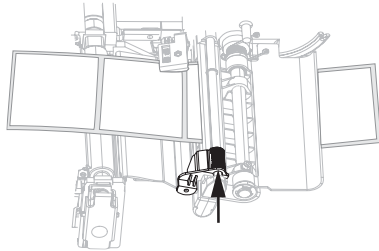

8. Set the printer to Peel-Off mode. See [Select Print Mode on page 73](#) for instructions.
9. Close the printhead assembly.

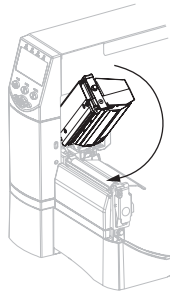

10. If the printer is paused (the Pause light is on), press PAUSE to enable printing. Peeling and liner take-up (if used) begin automatically.

Additional Steps for Cutter or Delayed Cut Mode

After completing [Beginning Steps for all Print Modes and Printer Options on page 41](#), continue with this section to operate the printer in Cutter or Delayed Cut mode.

To operate the printer in Cutter or Delayed Cut mode, complete these steps:



1. **Caution** • The cutter blade is sharp. Do not touch or rub the blade with your fingers.

Feed the media through the cutter (1).

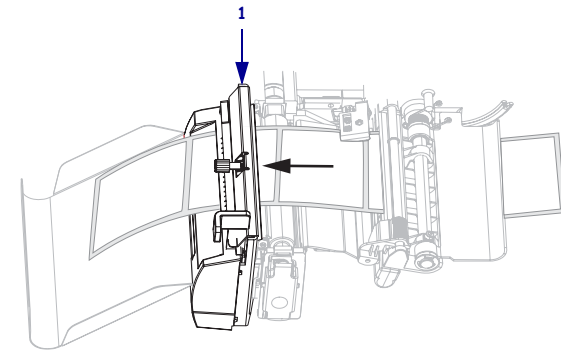

2. Slide in the media guide until it touches the outer edge of the media.

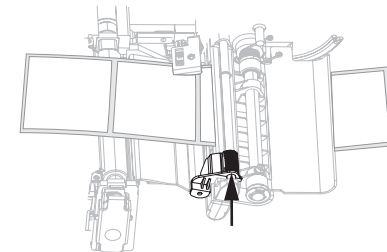

3. Set the printer to Cutter or Delayed Cut mode. See [Select Print Mode on page 73](#) for instructions.

4. Close the printhead assembly.

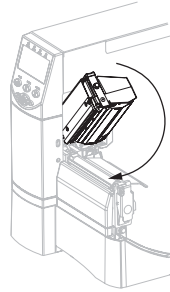

5. If the printer is paused (the Pause light is on), press PAUSE to enable printing. Cutting begins automatically.

Additional Steps for Rewind Mode

After completing [Beginning Steps for all Print Modes and Printer Options on page 41](#), continue with this section to operate the printer in Rewind mode. For additional procedures related to the rewind option, see [Routine Maintenance for the Rewind Option on page 106](#).

To operate the printer in Rewind mode, complete these steps:

1. Pull approximately 18 in. (500 mm) of media through the front of the printer.

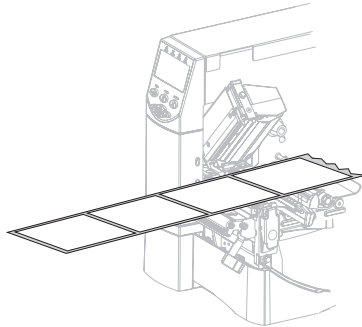

2. Feed the media over the peel assembly (1).

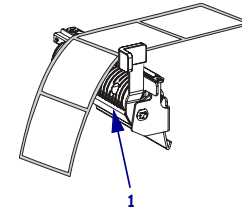

3. Feed the media under the media alignment roller (1).

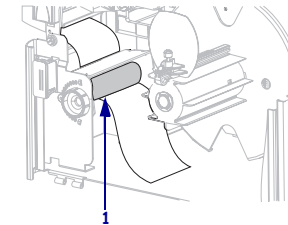

4. Loosen the thumbscrew on the rewind media guide.

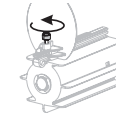

5. Slide the rewind media guide all the way out, and then fold it down.

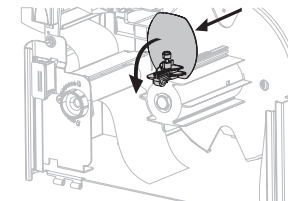

6. Slide an empty core onto the rewind spindle.

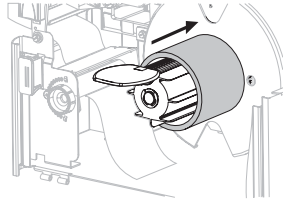

7. Wrap the media around the core and turn the rewind spindle counterclockwise to tighten the media. Ensure that the edge of the media is flush against the backplate of the rewind spindle.

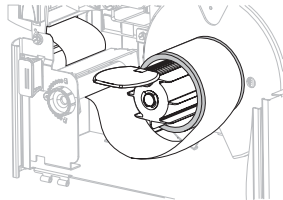

8. Fold up the rewind media guide, and then slide it in until it touches the media.

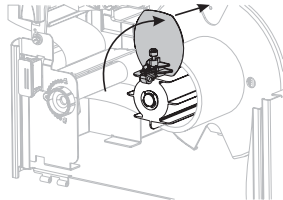

9. Tighten the thumbscrew on the rewind media guide.

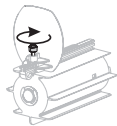

10. Slide in the media guide until it touches the outer edge of the media.

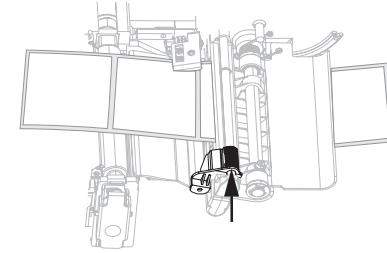

11. Set the printer to Rewind mode. See [Select Print Mode on page 73](#) for instructions.

12. Close the printhead assembly.

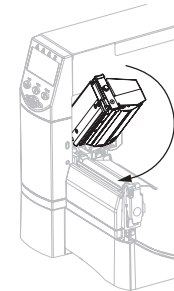

13. If the printer is paused (the Pause light is on), press PAUSE to enable printing. Rewinding begins automatically.

Load Ribbon

Always use ribbon that is wider than the media to protect the printhead from wear. For direct thermal printing, do not load ribbon in the printer.

The standard Thermal Transfer option (black ribbon spindle) uses ribbon coated on the outside, and the alternate Thermal Transfer option (gray ribbon spindle) uses ribbon coated on the inside. To avoid damaging your printer, follow the directions for the Thermal Transfer option installed in your printer.

Figure 8 shows the ribbon paths for ribbon coated on the outside and ribbon coated on the inside. The coated surfaces of the ribbon are shown in gray when they are visible. To determine which side of a ribbon is printed, see [Coated Side of Ribbon on page 35](#).

Figure 8 • Ribbon Path

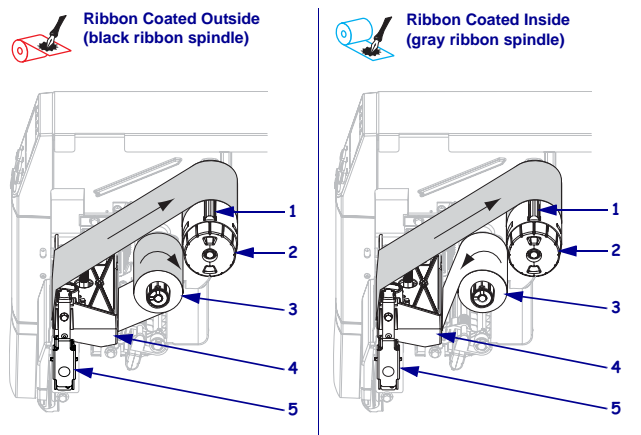

1	Tension blade
2	Ribbon take-up spindle
3	Ribbon supply spindle
4	Printhead assembly
5	Printhead release latch

Caution • While performing any tasks near an open printhead, remove all rings, watches, hanging necklaces, identification badges, or other metallic objects that could touch the printhead. You are not required to turn off the printer power when working near an open printhead, but Zebra recommends it as a precaution. If you turn off the power, you will lose all temporary settings, such as label formats, and you must reload them before you resume printing.

To load ribbon, complete these steps:

- Set the ribbon supply spindle for normal or low tension.
 - To place the ribbon supply spindle in the normal position, firmly pull out the spindle end cap until it extends and clicks in place, as shown in Figure 9. Use this setting for most applications.
 - To place the ribbon supply spindle in the low-tension position, firmly push in the end cap until it retracts and clicks in place, as shown in Figure 9. Use this setting when using a narrow ribbon or if normal tension hampers ribbon movement.

Figure 9 • Ribbon Spindle—Normal and Low Tension

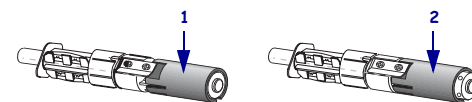

1	Normal Position (Spindle End Cap Extended)
2	Low-Tension Position (Spindle End Cap Retracted)

- Press the printhead release latch to open the printhead assembly. Lift the printhead until it latches open.

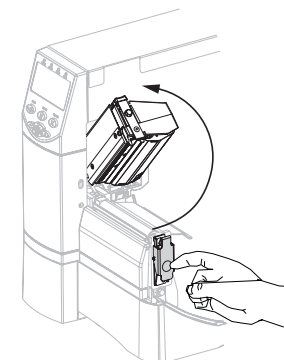

3. Insert the ribbon into the printer. In this step, follow the instructions for the Thermal Transfer option installed in your printer.



- a. Hold the ribbon with the loose end unrolling clockwise.



- b. Place the roll of ribbon on the ribbon supply spindle (1) and push it all the way back.

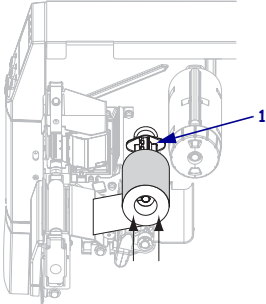

- c. Pull the end of the ribbon under the printhead assembly (1) and out the front of the printer. Extend the ribbon approximately 24 in. (610 mm) out of the printer.

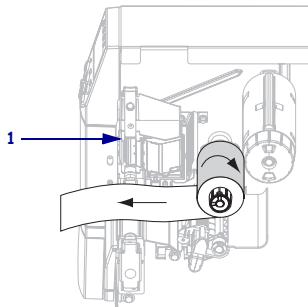

- a. Hold the ribbon with the loose end unrolling counterclockwise.



- b. Place the roll of ribbon on the ribbon supply spindle (1) and push it all the way back.

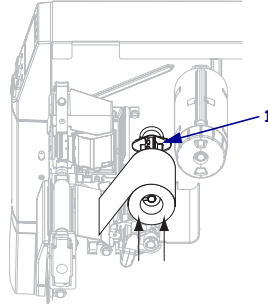

- c. Pull the end of the ribbon under the printhead assembly (1) and out the front of the printer. Extend the ribbon approximately 24 in. (610 mm) out of the printer.

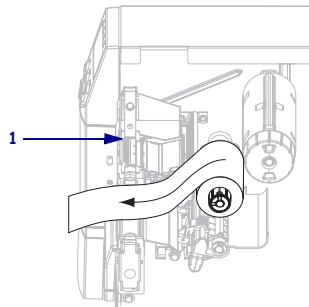

4. Close the printhead assembly.

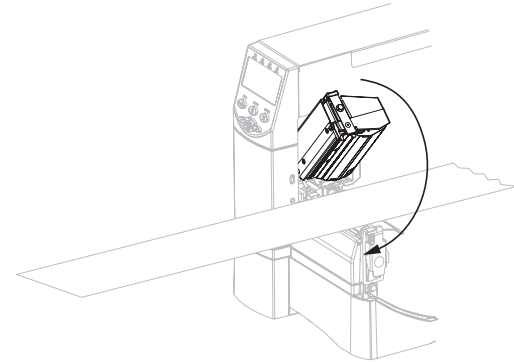

5. Wind the ribbon clockwise onto the ribbon take-up spindle (1).

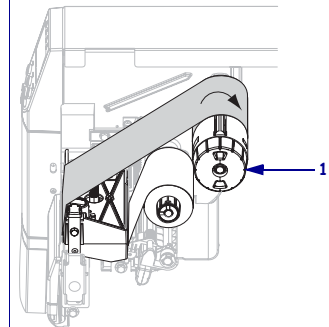
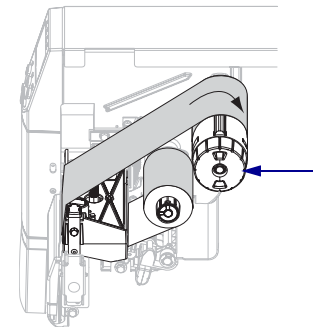

Remove Used Ribbon

To remove used ribbon, complete these steps:

1. **Caution** • Do not cut the ribbon directly on the ribbon take-up spindle. Doing so may damage the spindle.

If the ribbon has not run out, cut or break it before the ribbon take-up spindle (1).

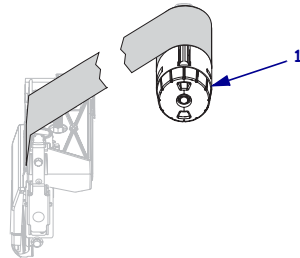

2. To loosen the ribbon, squeeze it against the ribbon take-up spindle tension blades (1). At the same time, turn the ribbon take-up spindle release knob counterclockwise (2). The tension blades collapse into the ribbon take-up spindle, loosening the ribbon.

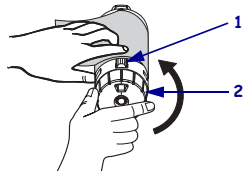

3. Slide the used ribbon off of the ribbon take-up spindle and discard.

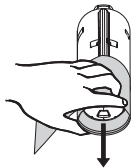

Calibrate the Printer

Auto Calibration

By default, the printer automatically calibrates on power up or when the printhead is closed. During auto calibration, the printer determines the label length and sensor settings.

The results of the auto calibration are stored in the printer's memory and are retained even if printer power is removed. These parameters remain in effect until the next calibration is performed.



Note • If the control panel settings for **MEDIA POWER UP** or **HEAD CLOSE** are set to **LENGTH, NO MOTION, or FEED**, the printer starts printing without auto calibrating. See [Select Media Power-Up Option on page 90](#) or [Select Head Close Option on page 90](#).

Manual Calibration

Perform a media and ribbon sensor calibration to reset the sensitivity of the sensors so the media and ribbon are detected more accurately. If you change the type of ribbon or media, your printer may operate better if you perform this calibration.

For instructions, refer to [Calibrate Media and Ribbon Sensor Sensitivity on page 84](#).

Adjust Printhead Pressure

You may need to adjust printhead pressure if printing is too light on one side, if you use thick media, or if the media drifts from side to side during printing.

See [Figure 10](#). The ZM400 pressure adjustment dials have four possible settings designated by blocks of increasing size embossed on the print mechanism. The smallest block (fully counterclockwise) is considered position 1, and the largest block (fully clockwise) is considered position 4. The ZM600 dials have seven settings instead of four.

Figure 10 • Printhead Pressure Adjustment Dials

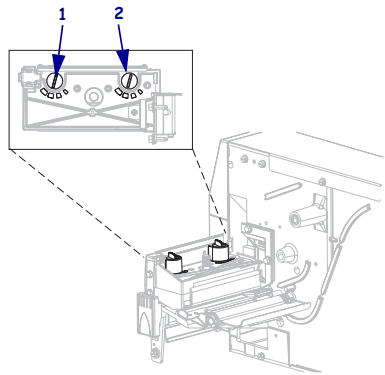

1	Outside dial
2	Inside dial

To set printhead pressure, complete these steps:

1. Use [Table 10](#) or [Table 11](#) to select the initial dial settings for your media, depending on which printer you have.

Table 10 • ZM400 Printhead Pressure

Media Width	Inside Dial	Outside Dial
1 in. (25.4 mm)	3	1
2 in. (51 mm)	4	1
3 in. (76 mm)	3	2
3.5 in. and up (89 mm and up)	3	3

Table 11 • ZM600 Printhead Pressure

Media Width	Inside Dial	Outside Dial
2 in. (50 mm)	6	1
3 in. (75 mm)	6	2
4 in. (100 mm)	7	3
5 in. (125 mm)	7	4
5.5 in. and up (140 mm and up)	6	6

2. If necessary, adjust the pressure adjustment dials as follows:

If the media...	Then...
Requires higher pressure to print well	Increase both dials one position.
Shifts left while printing	Increase the outside dial setting one position, or decrease the inside dial setting one position.
Shifts right while printing	Increase the inside dial setting one position, or decrease the outside dial setting one position.
Prints too lightly on the left side of the label.	Increase the inside dial setting one position.
Prints too lightly on the right side of the label.	Increase the outside dial setting one position.

4



Configuration

This section describes the control panel parameters that are used to configure the printer for operation.

Contents

- Setup Mode 64
- Enter Setup Mode 64
- Exit Setup Mode 65
- Change Password-Protected Parameters 66
- Default Password Value 66
- Disable the Password Protection Feature 66
- Print a Configuration Label 67
- Print a Network Configuration Label 68
- Control Panel Parameters 69
- How to View or Modify Parameters 69
- Additional Parameters 69
- Standard Printer Parameters 70

Setup Mode

After you have installed the media and ribbon and the Power-On Self Test (POST) is complete, the control panel displays **PRINTER READY**. You may now set printer parameters for your application using the control panel display and the buttons directly below it. If it becomes necessary to restore the initial printer defaults, see [FEED and PAUSE Self Test on page 129](#).



Important • Certain printing conditions may require that you adjust printing parameters, such as print speed, darkness, or print mode. These conditions include (but are not limited to):

- printing at high speeds
- peeling the media
- the use of extremely thin, small, synthetic, or coated labels

Because these and other factors affect print quality, run tests to determine the best combination of printer settings and media for your application. A poor match may limit print quality or print rate, or the printer may not function properly in the desired print mode.

Enter Setup Mode

To enter Setup Mode, complete these steps:

1. Press SETUP/EXIT.
2. Press PLUS (+) or MINUS (-) to scroll through the parameters.
3. Press SELECT to select and deselect the parameters.

Exit Setup Mode

To leave Setup mode, complete these steps:

1. Press SETUP/EXIT.

The LCD displays **SAVE CHANGES**.

2. Press PLUS (+) or MINUS (-) to display the save options:

LCD	Description
PERMANENT	Stores values in the printer even when power is turned off.
TEMPORARY	Saves the changes until power is turned off.
CANCEL	Cancels all changes made since you entered Setup mode, except for changes made to the darkness and tear-off settings, which go into effect as soon as they are made.
LOAD DEFAULTS	Restores all parameters other than the network settings back to the factory defaults. Use care when loading defaults because you will need to reload all settings that you changed manually.  Note • Loading factory defaults causes the printer to auto-calibrate.
LOAD LAST SAVE	Loads values from the last permanent save.
DEFAULT NET	Restores the wired and wireless network settings back to factory defaults.

3. Press SETUP/EXIT to select the displayed choice.

When the configuration and calibration sequence is done, **PRINTER READY** displays.

Change Password-Protected Parameters

Certain parameters, including the communication parameters, are password-protected by factory default.

Caution • Do not change password-protected parameters unless you have a complete understanding of the parameters' functions. If the parameters are set incorrectly, the printer may function unpredictably.

The first time that you attempt to change a password-protected parameter, the printer displays **ENTER PASSWORD**. Before you can change the parameter, you must enter the four-digit numeric password. After you have entered the password correctly, you do not have to enter it again unless you leave Setup mode by pressing SETUP/EXIT or by turning off (O) the printer.

To enter a password for a password-protected parameter, complete these steps:

1. At the password prompt, use MINUS (-) to change the selected digit position.
2. When you have selected the digit that you wish to change, use PLUS (+) to increase the selected digit value. Repeat these two steps for each digit of the password.
3. After entering the password, press SELECT.
The parameter you selected to change is displayed. If the password was entered correctly, you can change the value.

Default Password Value

The default password value is 1234. The password can be changed using the Zebra Programming Language (ZPL) command `^KP` (Define Password) or using the printer's web pages (ZebraNet[®] 10/100 Print Server, or Wireless Plus Print Server required).

Disable the Password Protection Feature

You can disable the password protection feature so that it no longer prompts you for a password by setting the password to 0000 via the `^KP` ZPL command. To re-enable the password-protection feature, send the ZPL command `^KPx`, where x can be any number from 1 to 9999.

Print a Configuration Label

A configuration label lists the printer settings that are stored in configuration memory. After you load the media, print a configuration label as a record of your printer's current settings. Keep the label to use when troubleshooting printing problems.

To print a configuration label, complete these steps:

1. On the control panel, press SETUP/EXIT.
2. Press PLUS (+) or MINUS (-) to scroll through the parameters until you reach **LIST SETUP**.
3. Press SELECT to select the parameter.
4. Press PLUS (+) to confirm printing.

A configuration label prints (Figure 11).

Figure 11 • Configuration Label

PRINTER CONFIGURATION	
Zebra Technologies	
ZTC ZM400-200@1 ZPL	
ZMR263475C	
410.....	DARKNESS
2 IPB.....	PRINT SPEED
+050.....	TEAR OFF
.....	TEAR OFF
CONTINUOUS.....	PRINT MODE
TRANSMISSIVE.....	SENSOR SELECT
.....	PRINT METHOD
500.....	PRINT WIDTH
1500.....	LABEL LENGTH
38.0IN 88MM.....	MAXIMUM LENGTH
PRINT OFF.....	EARLY WARNING
NOT CONNECTED.....	USB COMM.
BIDIRECTIONAL.....	PARALLEL COMM.
RS232.....	SERIAL COMM.
8000.....	BAUD
8 BIT.....	DATA BITS
NONE.....	PARITY
NONE/OFF.....	HST HANDSHAKE
NONE.....	PROTOCOL
000.....	NETWORK ID
NORMAL MODE.....	COMMUNICATIONS
< > 75H.....	CONTROL PREFIX
< > 3EH.....	FORMAT PREFIX
< > 3CH.....	DELIMITER CHR
2PL 1.....	2PL MODE
CALIBRATION.....	MEDIA POWER UP
CALIBRATION.....	HEAD CLIP
DEFAULT.....	BACKFEED
+000.....	BASE TSP
+0000.....	LEFT POSITION
DISABLED.....	REPRINT MODE
051.....	WEB S.
086.....	MEDIA S.
072.....	RIBBON S.
100.....	TARE LABEL
050.....	MARK S.
000.....	TRANS GAIN
035.....	TRANS BASE
147.....	TRANS BRIGHT
200.....	RIBBON GAIN
000.....	MARK GAIN
000000.....	MODES DISABLED
000000.....	MODES DISABLED
RESOLUTION.....	RESOLUTION
V37.....	HEROGRAM ID
0.0.0.....	OPTION FIRMWARE
CUSTOMIZED.....	CONFIGURATION
NONE.....	OPTION MEMORY
1158H.....	1158H
2048H.....	ONBOARD FLASH
NONE.....	FORMAT CONVERT
F4 VERSION.....	IDLE DISPLAY
04/10/09.....	RTC DATE
18:27.....	RTC TIME
10.760 IN.....	NONVolatile CNTR
2.800 IN.....	RESET CNTRL
10.760 IN.....	RESET CNTRL
27.332 CH.....	NONVolatile CNTR
5.980 CH.....	RESET CNTRL
27.332 CH.....	RESET CNTRL
.....	SELECTED ITEMS
.....	PASSWORD LEVEL
.....
FIRMWARE IN THIS PRINTER IS COPYRIGHTED	

Print a Network Configuration Label

If you are using a print server, you can print a network configuration label after the printer is connected to the network.

To print a network configuration label, complete these steps:

1. On the control panel, press SETUP/EXIT.
2. Press PLUS (+) or MINUS (-) to scroll through the parameters until you reach **LIST NETWORK**.
3. Press SELECT to select the parameter.
4. Press PLUS (+) to confirm printing.

A network configuration label prints (Figure 12). An asterisk designates whether the wired or wireless print server is active. If no wireless print server is installed, the wireless portion of the label does not print.

Figure 12 • Network Configuration Label (With a Wireless Print Server Installed)

Network Configuration	
Zebra Technologies	
ZTC ZM400-200@1 ZPL	
ZMR263475C	
0.0.0.....	OPTION FIRMWARE
.....	PRIMARY NETWORK
.....	LOAD FROM EXIT
.....	ACTIVE PRINTSERVER
External Wired	
ALL.....	IP PROTOCOL
000.000.000.000.....	IP ADDRESS
255.255.255.000.....	SUBNET MASK
000.000.000.000.....	DEFAULT GATEWAY
000.000.000.000.....	WINS SERVER IP
YES.....	TIMEOUT CHECKING
300.....	TIMEOUT VALUE
000.....	ARP INTERVAL
3100.....	BASE RAW PORT
Internal Wired	
ALL.....	IP PROTOCOL
010.004.004.116.....	IP ADDRESS
255.255.255.000.....	SUBNET MASK
010.003.004.001.....	DEFAULT GATEWAY
010.000.001.000.....	WINS SERVER IP
YES.....	TIMEOUT CHECKING
300.....	TIMEOUT VALUE
000.....	ARP INTERVAL
3100.....	BASE RAW PORT
00074604160.....	MAC ADDRESS
Wireless	
ALL.....	IP PROTOCOL
000.000.000.000.....	IP ADDRESS
255.255.255.000.....	SUBNET MASK
000.000.000.000.....	DEFAULT GATEWAY
000.000.000.000.....	WINS SERVER IP
YES.....	TIMEOUT CHECKING
300.....	TIMEOUT VALUE
000.....	ARP INTERVAL
NO.....	CARD INSERTED
NO.....	CARD REQ ID
00000H.....	CARD PRODUCT ID
000000000000.....	MAC ADDRESS
YES.....	DRIVER INSTALLED
.....	OPERATING MODE
125.....	ESSIO
10.....	TX POWER
ON.....	1 Mb/s
ON.....	2 Mb/s
ON.....	5.5 Mb/s
ON.....	11 Mb/s
ON.....	CURRENT TX RATE
DIVERSITY.....	RECEIVE ANTENNA
DIVERSITY.....	TRANSMIT ANTENNA
OPEN.....	WEP TYPE
NONE.....	WLAN SECURITY
.....	WEP INDEX
.....	POWER SIGNAL
LONG.....	PREAMBLE
NO.....	POSTCARD
ON.....	PULSE ENABLED
OFF.....	PULSE RATE
.....	INTL MODE
07FFH.....	CHANNEL MASK

Control Panel Parameters

Use the LCD on the control panel to view and adjust printer settings.

How to View or Modify Parameters

While viewing parameters, press PLUS (+) to continue to the next parameter, or press MINUS (-) to return to the previous parameter in the cycle. Press SELECT when you want to modify a parameter or view its options. When a parameter is changed, an asterisk (*) appears in the upper left corner of the display to indicate that the value is different from the one currently active in the printer.



Note • Your label preparation software or the printer driver may override adjustments made through the control panel. Refer to the software or driver documentation for more information.

Additional Parameters

Additional parameters appear in the following situations.

- When a wired print server is installed in the printer. For more information, refer to the ZebraNet 10/100 Print Server User and Reference Guide
- When a wireless print server is installed in the printer. Refer to the ZebraNet Wireless Print Server and Wireless Plus Print Server User Guide.
- When a Radio Frequency Identification (RFID) reader is installed. Refer to the RFID Programming Guide for more information.

Copies of these manuals are available at <http://www.zebra.com/manuals> or on the user CD that came with your printer.

Standard Printer Parameters

Table 12 shows parameters in the order in which they are displayed when you press PLUS (+) after entering Setup mode.

Table 12 • Printer Parameters (Page 1 of 26)



Parameter	Action/Explanation
ZPL, XML, APL-D, APL-I 	Adjust Print Darkness/Density Darkness (burn duration) settings depend on a variety of factors, including ribbon type, media type, and the condition of the printhead. You may adjust the darkness for consistent high-quality printing.  Important • Set the darkness to the lowest setting that provides good print quality. If the darkness is set too high, the ink may smear, the ribbon may burn through, or the printhead may wear prematurely.
EPL only 	If printing is too light or if there are voids in printed areas, increase the darkness. If printing is too dark or if there is spreading or bleeding of printed areas, decrease the darkness. The FEED Self Test on page 126 can be used to determine the best darkness setting. You may want to adjust darkness while performing the PAUSE Self Test on page 125. Because the darkness setting takes effect immediately, you can see the results on labels that are currently printing. Darkness settings also may be changed by the driver or software settings. Default Value (ZPL, XML, APL-D, APL-I): +10 Range (ZPL, XML, APL-D, APL-I): 00 to +30 Default Value (EPL): +7 Range (EPL): 00 to +15 To change the value shown: 1. Press SELECT to select the parameter. 2. Press PLUS (+) to increase darkness. 3. Press MINUS (-) to decrease darkness. 4. Press SELECT to accept any changes and deselect the parameter.

Table 12 • Printer Parameters (Page 2 of 26)

Parameter	Action/Explanation
	<p>Adjust Print Speed Adjusts the speed for printing a label (given in inches per second). Slower print speeds typically yield better print quality. Print speed changes take effect upon exiting Setup mode.</p> <p>Default Value (ZPL, XML, APL-I, EPL): 2 IPS Default Value (APL-D): 6 IPS</p> <p>Range:</p> <ul style="list-style-type: none"> • 200 dpi: 2 to 10 IPS • 300 dpi: 2 to 8 IPS • 600 dpi: 1 to 4 IPS <p>To change the value shown:</p> <ol style="list-style-type: none"> 1. Press SELECT to select the parameter. 2. Press PLUS (+) to increase the value. 3. Press MINUS (-) to decrease the value. 4. Press SELECT to accept any changes and deselect the parameter.

Table 12 • Printer Parameters (Page 3 of 26)

Parameter	Action/Explanation				
	<p>Adjust the Tear-Off Position This parameter establishes the position of the media over the tear-off/peel-off bar after printing.</p> <p>See Figure 13. Higher numbers move the media out (the tear line moves closer to the leading edge of the next label), and lower numbers move the media in (the tear line moves closer to the edge of the label just printed).</p> <div style="text-align: center;">  </div> <table border="1" style="margin-left: auto; margin-right: auto;"> <tr> <td style="text-align: center;">1</td> <td>Media direction</td> </tr> <tr> <td style="text-align: center;">2</td> <td>Factory-set tear line location at position 00</td> </tr> </table> <p>Default Value (ZPL, EPL, APL-I): 0 Range (ZPL, EPL, APL-I): -120 to +120</p> <p>Default Value (APL-D): +128i Range (APL-D): +00i to +999i (inches), 0m to 2537m (metric)</p> <p>To change the value shown:</p> <ol style="list-style-type: none"> 1. Press SELECT to select the parameter. 2. Press PLUS (+) to increase the value. Each press adjusts the tear-off position by four dot rows. 3. Press MINUS (-) to decrease the value. Each press adjusts the tear-off position by four dot rows. 4. Press SELECT to accept any changes and deselect the parameter. 	1	Media direction	2	Factory-set tear line location at position 00
1	Media direction				
2	Factory-set tear line location at position 00				

Table 12 • Printer Parameters (Page 4 of 26)



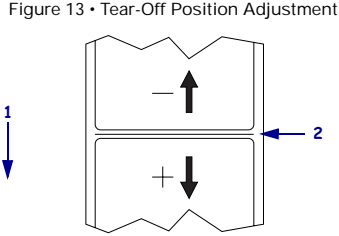

Parameter	Action/Explanation
 PRINT MODE -TEAR OFF +	Select Print Mode This parameter tells the printer how printed labels will be removed. Make sure that you select a print mode that is compatible with your printer and printer options. For information about how the print modes work with different printer options, see Print Modes and Printer Options on page 38 . Default Value: TEAR-OFF Selections: TEAR-OFF, PEEL-OFF, CUTTER, DELAYED CUT, LINERLESS-P, LINERLESS-R, LINERLESS-T, REWIND  Note • The linerless selections apply only to printers that have the Linerless option. To change the value shown: 1. Press SELECT to select the parameter. 2. Press PLUS (+) or MINUS (-) to scroll through the options. 3. Press SELECT to accept any changes and deselect the parameter.
APL-D only  COMPAT. MODE -OFF +	Set APL-D Compatibility Mode Sets compatibility with DPL printers. Default Value: OFF Selections: ON, OFF To change the value shown: 1. Press SELECT to select the parameter. 2. Press PLUS (+) or MINUS (-) to scroll through the options. 3. Press SELECT to accept any changes and deselect the parameter.
APL-D only  CONTROL CODES -STANDARD +	Set APL-D Control Codes Default Value: STANDARD Selections: STANDARD, MAINFRAME To change the value shown: 1. Press SELECT to select the parameter. 2. Press PLUS (+) or MINUS (-) to scroll through the options. 3. Press SELECT to accept any changes and deselect the parameter.
APL-D only  MODULE A -NONE +	Set Module A Storage Device for APL-D Default Value: NONE Selections: NONE, RAM 1, RAM 2, FLASH 1, FLASH 2 To change the value shown: 1. Press SELECT to select the parameter. 2. Press PLUS (+) or MINUS (-) to scroll through the options. 3. Press SELECT to accept any changes and deselect the parameter.

Table 12 • Printer Parameters (Page 5 of 26)



Parameter	Action/Explanation
APL-D only  MODULE B -NONE +	Set Module B Storage Device for APL-D Default Value: NONE Selections: NONE, RAM 1, RAM 2, FLASH 1, FLASH 2 To change the value shown: 1. Press SELECT to select the parameter. 2. Press PLUS (+) or MINUS (-) to scroll through the options. 3. Press SELECT to accept any changes and deselect the parameter.
APL-I only  RESOLUTION -5 MIL +	Set Printer Resolution for APL-I Sets the dot size for backward compatibility with some older APL-I printers. Default Value: 5 MIL Selections: 5 MIL, 10 MIL, 15 MIL To change the value shown: 1. Press SELECT to select the parameter. 2. Press PLUS (+) or MINUS (-) to scroll through the options. 3. Press SELECT to accept any changes and deselect the parameter.
 MEDIA TYPE -GAP / NOTCH +	Set Media Type This parameter tells the printer the type of media that you are using (see Types of Media on page 33 for more information). Selecting continuous media requires that you include a label length instruction in your label format (^LLxxx if you are using ZPL or ZPL II). When non-continuous media is selected, the printer feeds media to calculate label length (the distance between two recognized registration points of the inter-label gap, webbing, or alignment notch or hole). Default Value: GAP/NOTCH Selections: GAP/NOTCH, MARK, CONTINUOUS To change the value shown: 1. Press SELECT to select the parameter. 2. Press PLUS (+) or MINUS (-) to scroll through the options. 3. Press SELECT to accept any changes and deselect the parameter.

Table 12 • Printer Parameters (Page 6 of 26)

Parameter	Action/Explanation														
	<p>Select Print Method</p> <p>The print method parameter tells the printer the method of printing that you want to use: direct thermal (no ribbon) or thermal transfer (using thermal transfer media and ribbon).</p> <p>Default Value: THERMAL TRANSFER</p> <p>Selections: THERMAL TRANSFER, DIRECT THERMAL</p> <p>To change the value shown:</p> <ol style="list-style-type: none"> 1. Press SELECT to select the parameter. 2. Press PLUS (+) or MINUS (-) to scroll through the options. 3. Press SELECT to accept any changes and deselect the parameter. 														
	<p>Set Print Width</p> <p>This parameter specifies the printable area across the width of the label. Table 13 shows the ranges and default values for print width, which are based on the printer model and the printhead resolution.</p> <p style="text-align: center;">Table 13 • Print Width Ranges and Maximum Values</p> <table border="1"> <thead> <tr> <th rowspan="2">Printhead Resolution</th> <th colspan="2">Printer</th> </tr> <tr> <th>ZM400</th> <th>ZM600</th> </tr> </thead> <tbody> <tr> <td>200 dpi</td> <td>Default Value: 832 Range: 2 to 832 dots</td> <td>Default Value: 1344 Range: 2 to 1344 dots</td> </tr> <tr> <td>300 dpi</td> <td>Default Value: 1248 Range: 2 to 1248 dots</td> <td>Default Value: 1984 Range: 2 to 1984 dots</td> </tr> <tr> <td>600 dpi</td> <td>Default Value: 2496 Range: 2 to 2496 dots</td> <td>N/A</td> </tr> </tbody> </table> <p>Note • Setting the width too narrow can result in portions of a label format not being printed on the media. Setting the width too wide wastes formatting memory and can cause printing off of the label and on the platen roller. This setting can affect the horizontal position of the label format if the image was inverted using the ^POI ZPL II command.</p> <p>To change the value shown:</p> <ol style="list-style-type: none"> 1. Press SELECT to select the parameter. 2. Press PLUS (+) or MINUS (-) to change the value shown. 3. Press SELECT to accept any changes and deselect the parameter. 	Printhead Resolution	Printer		ZM400	ZM600	200 dpi	Default Value: 832 Range: 2 to 832 dots	Default Value: 1344 Range: 2 to 1344 dots	300 dpi	Default Value: 1248 Range: 2 to 1248 dots	Default Value: 1984 Range: 2 to 1984 dots	600 dpi	Default Value: 2496 Range: 2 to 2496 dots	N/A
Printhead Resolution	Printer														
	ZM400	ZM600													
200 dpi	Default Value: 832 Range: 2 to 832 dots	Default Value: 1344 Range: 2 to 1344 dots													
300 dpi	Default Value: 1248 Range: 2 to 1248 dots	Default Value: 1984 Range: 2 to 1984 dots													
600 dpi	Default Value: 2496 Range: 2 to 2496 dots	N/A													

Table 12 • Printer Parameters (Page 7 of 26)

Parameter	Action/Explanation						
<p>ZPL, XML, EPL, APL-I</p> <p>APL-D only</p>	<p>Set Maximum Label Length</p> <p>This parameter is used during the media portion of the calibration process. Always set maximum label length to a value that is at least 1.0 in. (25.4 mm) greater than the actual label length (Figure 14). If the value is set to a smaller value than the label length, the printer assumes that continuous media is loaded, and the printer cannot calibrate.</p> <p>For example, if the label length is 5.0 inches (126 mm) including the interlabel gap, set the parameter for 6.0 inches (152 mm). If the label length is 7.5 inches (190 mm), set the parameter for 9.0 inches (229 mm).</p> <p style="text-align: center;">Figure 14 • Label Length</p> <table border="1"> <tbody> <tr> <td>1</td> <td>Label length (including interlabel gap)</td> </tr> <tr> <td>2</td> <td>Interlabel gap</td> </tr> <tr> <td>3</td> <td>Set maximum label length to approximately this value</td> </tr> </tbody> </table> <p>Default Value (ZPL, XML, EPL, APL-I): 39.0 inches (988 mm)</p> <p>Selections: Values are adjustable in one-inch (25.4 mm) increments</p> <p>Default Value (APL-D): 1200i</p> <p>Range: 1200i to</p> <p>To change the value shown:</p> <ol style="list-style-type: none"> 1. Press SELECT to select the parameter. 2. Press PLUS (+) or MINUS (-) to change the value shown. 3. Press SELECT to accept any changes and deselect the parameter. 	1	Label length (including interlabel gap)	2	Interlabel gap	3	Set maximum label length to approximately this value
1	Label length (including interlabel gap)						
2	Interlabel gap						
3	Set maximum label length to approximately this value						

Table 12 • Printer Parameters (Page 8 of 26)

Parameter	Action/Explanation
	<p>Set Early Warning for Maintenance When this feature is enabled, the printer provides warnings when the printhead needs to be cleaned.</p> <p>Default Value: MAINT. OFF Selections: MAINT. OFF, MAINTENANCE ON</p> <p>To change the Early Warning settings:</p> <ol style="list-style-type: none"> 1. Press SELECT to select the parameter. 2. When the LCD displays EARLY WARNING MAINTENANCE, press PLUS (+) or MINUS (-) to toggle between OFF and ON. (If you are prompted for a password, enter your password using the instructions in Change Password-Protected Parameters on page 66.) 3. Exit Setup mode and save changes to enable additional parameters related to the early warning system. 4. Enter Setup mode again and go to the following parameters to enter the printhead cleaning interval and the printhead life. 5. Press SELECT to accept any changes and deselect the parameter.
	<p>Set Printhead Cleaning Interval for Early Warning This parameter appears only when Early Warning for Maintenance is enabled. This value should correspond to the length of the media or ribbon roll that you are using.</p> <p>Default Value: 450 M/1476 FT Selections: 100 M/328 FT to 450 M/1476 FT in 50 M increments</p> <p>To change the value shown:</p> <ol style="list-style-type: none"> 1. Press SELECT to select the parameter. 2. Press PLUS (+) or MINUS (-) to set the printhead cleaning interval to the desired number of inches of media or ribbon. When the printhead reaches the set length, WARNING CLEAN PRINTHEAD appears on the LCD. If the alert function is enabled, the printer generates an alert. 3. Press SELECT to accept any changes and deselect the parameter.
	<p>Reset Printhead Cleaning Counter for Early Warning This parameter appears only when Early Warning for Maintenance is enabled.</p> <p>To reset the printhead cleaning counter:</p> <ol style="list-style-type: none"> 1. Press SELECT to select the parameter. 2. Did you clean the printhead? <ul style="list-style-type: none"> • If you cleaned the printhead, press PLUS (+) to select YES. • If you did not clean the printhead, press MINUS (-) to select NO. 3. Press SELECT to accept any changes and deselect the parameter.

Table 12 • Printer Parameters (Page 9 of 26)



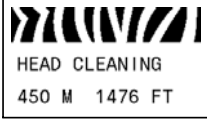
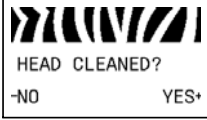

Parameter	Action/Explanation
	<p>Set Printhead Life for Early Warning This parameter appears only when Early Warning for Maintenance is enabled. Set this value to the number of inches of media that the printhead is expected to print.</p> <p>Default Value: 1,000,000 inches Range: 100 to 1,000,000 inches</p> <p>To change the value shown:</p> <ol style="list-style-type: none"> 1. Press SELECT to select the parameter. 2. Press MINUS (-) to move the cursor. 3. Press PLUS (+) to increase the value of the digit. When the printhead reaches the set length, WARNING REPLACE HEAD appears on the LCD. If the alert function is enabled, the printer generates an alert. 4. Press SELECT to accept any changes and deselect the parameter.
	<p>Reset Printhead Life Counter for Early Warning This parameter appears only when Early Warning for Maintenance is enabled.</p> <p>To reset the printhead life counter:</p> <ol style="list-style-type: none"> 1. Press SELECT to select the parameter. 2. Did you replace the printhead? <ul style="list-style-type: none"> • If you replaced the printhead, press PLUS (+) to select YES. • If you did not replace the printhead, press MINUS (-) to select NO. 3. Press SELECT to accept any changes and deselect the parameter.
	<p>View Non-Resettable Counter This parameter displays the total length of media that the printer has printed. You can use ZPL commands to change the unit of measure for this counter. For the commands, refer to the ZPL Programming Guide.</p>
	<p>View User-Controlled Counter 1 This parameter displays the total length of media that the printer has printed since this parameter was last reset. You can use ZPL commands to change the unit of measure and reset this counter. For the commands, refer to the ZPL Programming Guide.</p>
	<p>View User-Controlled Counter 2 This parameter displays the total length of media that the printer has printed since this parameter was last reset. You can use ZPL commands to change the unit of measure and reset this counter. For the commands, refer to the ZPL Programming Guide.</p>

Table 12 • Printer Parameters (Page 10 of 26)





Parameter	Action/Explanation
	<p>Print Counter Readings Prints a label that lists the odometer readings for the following:</p> <ul style="list-style-type: none"> the non-resettable counter the two user-controlled counters the Early Warning for Maintenance counters, which indicate when the printhead was last cleaned and the printhead life <p>If the Early Warning for Maintenance feature is disabled, the counters related to it do not print.</p> <p>To print a list of the odometer readings:</p> <ol style="list-style-type: none"> Press SELECT to select the parameter. Press PLUS (+) to print the odometer readings. Press SELECT to deselect the parameter.
	<p>List Fonts This option prints a label that lists the available fonts in the printer, including standard printer fonts plus any optional fonts. Fonts may be stored in RAM or Flash memory.</p> <p>To print a list of the available fonts:</p> <ol style="list-style-type: none"> Press SELECT to select the parameter. Press PLUS (+) to select PRINT. Press SELECT to deselect the parameter.
ZPL and XML only 	<p>List Bar Codes This option prints a label that lists the available bar codes in the printer. Bar codes may be stored in RAM or Flash memory.</p> <p>To print a list of the available bar codes:</p> <ol style="list-style-type: none"> Press SELECT to select the parameter. Press PLUS (+) to select PRINT. Press SELECT to deselect the parameter.
	<p>List Images This option prints a label that lists the available images stored in the printer's RAM, Flash memory, or optional memory card.</p> <p>To print a list of the available images:</p> <ol style="list-style-type: none"> Press SELECT to select the parameter. Press PLUS (+) to select PRINT. Press SELECT to deselect the parameter.

Table 12 • Printer Parameters (Page 11 of 26)





Parameter	Action/Explanation
	<p>List Formats This option prints a label that lists the available formats stored in the printer's RAM, Flash memory, or optional memory card.</p> <p>To print a list of the available formats:</p> <ol style="list-style-type: none"> Press SELECT to select the parameter. Press PLUS (+) to select PRINT. Press SELECT to deselect the parameter.
ZPL, XML, EPL, APL-D 	<p>List Setup This option prints a configuration label (see Figure 11 on page 67), which lists the current printer configuration.</p> <p>To print a configuration label:</p> <ol style="list-style-type: none"> Press SELECT to select the parameter. Press PLUS (+) to select PRINT. Press SELECT to deselect the parameter.
APL-I only 	
APL-I only 	<p>Print Software Configuration Label A software configuration label lists pages, formats, and bar codes that are defined for the printer. Other printer settings also are included.</p> <p>To print this label:</p> <ol style="list-style-type: none"> Press SELECT to select the parameter. Press PLUS (+) to select PRINT. Press SELECT to deselect the parameter.
APL-I only 	<p>Print Hardware Configuration Label A hardware configuration label lists the memory options, printer metrics, and printhead information.</p> <p>To print this label:</p> <ol style="list-style-type: none"> Press SELECT to select the parameter. Press PLUS (+) to select PRINT. Press SELECT to deselect the parameter.

Table 12 • Printer Parameters (Page 12 of 26)





Parameter	Action/Explanation
APL-I only 	Print Quality Test Label A print quality test label contains test bar codes and relevant printer settings. To print this label: 1. Press SELECT to select the parameter. 2. Press PLUS (+) to select PRINT . 3. Press SELECT to deselect the parameter.
APL-I only 	Print Pitch Test Label To print this label: 1. Press SELECT to select the parameter. 2. Press PLUS (+) to select PRINT . 3. Press SELECT to deselect the parameter.
	List Network Settings This option prints a network configuration label (see Figure 12 on page 68), which lists the settings for any print server that is installed. To print a network configuration label: 1. Press SELECT to select the parameter. 2. Press PLUS (+) to select PRINT . 3. Press SELECT to deselect the parameter.
ZPL, XML, EPL 	List All This option prints labels that list the available fonts, bar codes, images, formats, and the current printer and network configurations. To print labels for all settings: 1. Press SELECT to select the parameter. 2. Press PLUS (+) to select PRINT . 3. Press SELECT to deselect the parameter.
APL-I only 	Print Stored APL-I Page Up to 20 pages can be stored and printed. Selections: 0 through 19 Default Value: 0 To modify this parameter: • To increase the value, press the up arrow. • To decrease the value, press the down arrow.

Table 12 • Printer Parameters (Page 13 of 26)



Parameter	Action/Explanation
APL-I only 	Print Stored APL-I Format Up to 100 formats can be stored and printed. Selections: 0 through 99 Default Value: 0 To modify this parameter: • To increase the value, press the up arrow. • To decrease the value, press the down arrow.
ZPL and XML only 	Format Memory Card This option erases all previously stored information from the optional 64 MB flash chip on the Wireless Plus option board. This parameter appears only when a Wireless Plus option board with the flash chip populated is installed. Caution • This option completely erases the flash chip. To format a memory card: 1. Press SELECT to select the parameter. 2. Press PLUS (+) to select A: . If your printer is set to require a password, you are prompted to enter the password. 3. Enter the password. For instructions, see Change Password-Protected Parameters on page 66 . 4. Press the appropriate button again to select the desired card. The display shows ARE YOU SURE? . 5. Do you want to continue? • Press MINUS (-) to select NO to cancel the request and return to FORMAT CARD prompt. • Press PLUS (+) to select YES and begin initialization. When initialization is complete, the control panel displays FORMATTING CARD COMPLETED .  Note • Depending on the amount of memory in the memory card, initialization may take up to 5 minutes to complete. 6. Press SELECT to deselect the parameter.

Table 12 • Printer Parameters (Page 14 of 26)



Parameter	Action/Explanation
	<p>Initialize Flash Memory This option erases all previously stored information from Flash memory. Caution • This option completely erases the Flash memory.</p> <p>To initialize Flash memory:</p> <ol style="list-style-type: none"> 1. Press SELECT to select the parameter. 2. If prompted for a password, enter the printer password. For instructions, see Change Password-Protected Parameters on page 66. The display shows INITIALIZE FLASH? 3. Press PLUS (+) to select YES. The display shows ARE YOU SURE? 4. Do you want to continue? <ul style="list-style-type: none"> • Press MINUS (-) to select NO to cancel the request and return to the INITIALIZE FLASH prompt. • Press PLUS (+) to select YES and begin initialization. When initialization is complete, the control panel displays INITIALIZING MEMORY COMPLETED. <p> Note • Depending on the amount of free FLASH memory, initialization may take up to 1 minute to complete.</p> 5. Press SELECT to accept any changes and deselect the parameter.
	<p>Print Sensor Profile A sensor profile shows sensor settings compared to actual sensor readings. This label (which will extend across several actual labels or tags) can be used to troubleshoot printing problems. To interpret the results of the sensor profile, see Sensor Profile on page 131.</p>  <p>To print a sensor profile:</p> <ol style="list-style-type: none"> 1. Press SELECT to select the parameter. 2. Press PLUS (+) to start this standard calibration procedure and print a media sensor profile. 3. If the sensitivity of the sensors must be adjusted, perform Calibrate Media and Ribbon Sensor Sensitivity on page 84. 4. Press SELECT to accept any changes and deselect the parameter.

Table 12 • Printer Parameters (Page 15 of 26)



Parameter	Action/Explanation
	<p>Calibrate Media and Ribbon Sensor Sensitivity Use this procedure to adjust sensitivity of media and ribbon sensors.</p> <p> Important • Follow this procedure exactly as presented. All of the steps must be performed even if only one of the sensors requires adjustment. You may press MINUS (-) at any step in this procedure to cancel the process.</p> <p>To perform a media and ribbon sensor calibration:</p> <ol style="list-style-type: none"> 1. Press SELECT to select the parameter. 2. Press PLUS (+) to start the calibration procedure. The LOAD BACKING prompt displays. 3. Open the printhead. 4. Remove approximately 8 in. (203 mm) of labels from the backing, and pull the media into the printer so that only the backing is between the media sensors. 5. Leave the printhead open. 6. Press PLUS (+) to continue. The REMOVE RIBBON prompt displays. 7. Remove the ribbon (if used). 8. Close the printhead. 9. Press PLUS (+) to continue. The message CALIBRATING PLEASE WAIT displays. The printer adjusts the scale (gain) of the signals that it receives from the media and ribbon sensors based on the specific media and ribbon combination being used. On the sensor profile, this essentially corresponds to moving the peak of the graph up or down to optimize the readings for your application. When calibration is complete, RELOAD ALL displays. 10. Open the printhead and pull the media forward until a label is positioned under the media sensor. 11. Reload the ribbon (if used). 12. Close the printhead. 13. Press PLUS (+) to continue. The printer performs an auto-calibration. During this process, the printer checks the readings for the media and ribbon based on the new scale established, determines the label length, and determines the print mode. To see the new readings on the new scale, print a sensor profile. 14. Press SELECT to accept any changes and deselect the parameter.

Table 12 • Printer Parameters (Page 16 of 26)

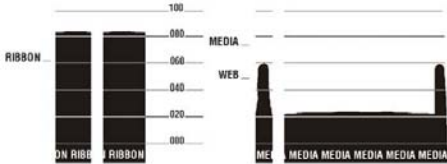



Parameter	Action/Explanation
 PARALLEL COMM. -BIDIRECTIONAL +	Set Parallel Communications Select the communications port that matches the one being used by the host computer. Default Value: BIDIRECTIONAL Selections: BIDIRECTIONAL, UNIDIRECTIONAL To change the value shown: 1. Press SELECT to select the parameter. 2. Press PLUS (+) or MINUS (-) to scroll through the options. 3. Press SELECT to accept any changes and deselect the parameter.
ZPL and XML only  SERIAL COMM. -RS232 +	Set Serial Communications Select the communications port that matches the one being used by the host computer. This setting applies only when the serial port is used.  Note • Select RS232 if you are using an external adapter to enable RS422/485 operation. Default Value: RS232 Selections: RS232, RS485 MULTIDROP To change the value shown: 1. Press SELECT to select the parameter. 2. Press PLUS (+) or MINUS (-) to scroll through the options. 3. Press SELECT to accept any changes and deselect the parameter.
 BAUD -9600 +	Set Baud This setting applies only when the serial port is used. The baud setting of the printer must match the baud setting of the host computer for accurate communications to take place. Select the value that matches the one being used by the host computer. Default Value: 9600 Selections (ZPL, XML): 300, 600, 1200, 2400, 4800, 9600, 14400, 19200, 28800, 38400, 57600, 115200 Selections (EPL): 1200, 2400, 4800, 9600, 19200, 38400, 57600, 115200 To change the value shown: 1. Press SELECT to select the parameter. 2. Press PLUS (+) or MINUS (-) to scroll through the options. 3. Press SELECT to accept any changes and deselect the parameter.

Table 12 • Printer Parameters (Page 17 of 26)



Parameter	Action/Explanation
 DATA BITS -8 BITS	Set Data Bits This setting applies only when the serial port is used. The data bits of the printer must match the data bits of the host computer for accurate communications to take place. Set the data bits to match the setting being used by the host computer. Default Value: 8 BITS Selections: 7 BITS, 8 BITS To change the value shown: 1. Press SELECT to select the parameter. 2. Press PLUS (+) or MINUS (-) to toggle between the options. 3. Press SELECT to accept any changes and deselect the parameter.
 PARITY -NONE +	Set Parity This setting applies only when the serial port is used. The parity of the printer must match the parity of the host computer for accurate communications to take place. Select the parity that matches the one being used by the host computer. Default Value: NONE Selections: EVEN, ODD, NONE To change the value shown: 1. Press SELECT to select the parameter. 2. Press PLUS (+) or MINUS (-) to scroll through the options. 3. Press SELECT to accept any changes and deselect the parameter.
 HOST HANDSHAKE -XON/XOFF +	Set Host Handshake This setting applies only when the serial port is used. The handshake protocol of the printer must match the handshake protocol of the host computer for communication to take place. Select the handshake protocol that matches the one being used by the host computer. Default Value (ZPL, XML, APL-D): XON/XOFF Selections (ZPL, XML): XON/XOFF, DSR/DTR, RTS/CTS Default Value (APL-I): XON/XOFF Selections (APL-I): XON/XOFF, DSR/DTR, RTS/CTS, APL-I Default Value (EPL): DTR & XON/XOFF Selections (EPL): DTR & XON/XOFF, DTR To change the value shown: 1. Press SELECT to select the parameter. 2. Press PLUS (+) or MINUS (-) to scroll through the options. 3. Press SELECT to accept any changes and deselect the parameter.

Table 12 • Printer Parameters (Page 18 of 26)





Parameter	Action/Explanation
APL-I only  STATUS RESP -ON +	Send APL-I Status Response Determines if a response is sent after inquiry commands. Default Value: ON Selections: ON, OFF To change the value shown: 1. Press SELECT to select the parameter. 2. Press PLUS (+) or MINUS (-) to toggle between the options. 3. Press SELECT to accept any changes and deselect the parameter.
ZPL and XML only  PROTOCOL -NONE +	Set Protocol Protocol is a type of error checking system. Depending on the selection, an indicator may be sent from the printer to the host computer signifying that data has been received. Select the protocol that is requested by the host computer. Further details on protocol can be found in the ZPL Programming Guide. Default Value: NONE Selections: NONE, ZEBRA, ACK_NAK  Note • ZEBRA is the same as ACK_NAK , except that ZEBRA response messages are sequenced. If ZEBRA is selected, the printer must use DSR/DTR for host handshake protocol. To change the value shown: 1. Press SELECT to select the parameter. 2. Press PLUS (+) or MINUS (-) to scroll through the options. 3. Press SELECT to accept any changes and deselect the parameter.
ZPL and XML only  NETWORK ID 000	Set Network ID This parameter assigns a unique number to the printer when the printer is operating in an RS422/485 multi-drop network environment (an external RS422/485 adapter is required). This gives the host computer the means to address a specific printer. This does not affect TCP/IP or IPX networks. Default Value: 000 Range: 000 to 999 To change the value shown: 1. Press SELECT to select the parameter. 2. Press MINUS (-) to move to the next digit position. 3. Press PLUS (+) to increase the value of the digit. 4. Press SELECT to accept any changes and deselect the parameter.

Table 12 • Printer Parameters (Page 19 of 26)





Parameter	Action/Explanation
 COMMUNICATIONS NORMAL MODE	Set Communications Mode The communication diagnostics mode is a troubleshooting tool for checking the interconnection between the printer and the host computer. For more information, see Communications Diagnostics Test on page 130 . Default Value: NORMAL MODE Selections: NORMAL MODE, DIAGNOSTICS To select communication diagnostics mode: 1. Press SELECT to select the parameter. 2. Press PLUS (+) or MINUS (-) to toggle between the options. 3. Press SELECT to accept any changes and deselect the parameter.
ZPL and XML only  CONTROL PREFIX -7E ~ +	Set Control Prefix Character The printer looks for this two-digit hex character to indicate the start of a ZPL/ZPL II control instruction.  Note • Do not use the same hex value for the control, format, and delimiter character. The printer must see different characters to work properly. Default Value: 7E ~ Range: 00 to FF To change the value shown: 1. Press SELECT to select the parameter. 2. Press MINUS (-) to move to the next digit position. 3. Press PLUS (+) to increase the value of the digit. 4. Press SELECT to accept any changes and deselect the parameter.
ZPL and XML only  FORMAT PREFIX -5E ^ +	Set Format Prefix Character The format prefix is a two-digit hex value used as a parameter place marker in ZPL/ZPL II format instructions. The printer looks for this hex character to indicate the start of a ZPL/ZPL II format instruction. See the ZPL Programming Guide for more information.  Note • Do not use the same hex value for the control, format, and delimiter character. The printer must see different characters to work properly. Default Value: 5E ^ Range: 00 to FF To change the value shown: 1. Press SELECT to select the parameter. 2. Press MINUS (-) to move to the next digit position. 3. Press PLUS (+) to increase the value of the digit. 4. Press SELECT to accept any changes and deselect the parameter.

Table 12 • Printer Parameters (Page 20 of 26)

Parameter	Action/Explanation
ZPL and XML only 	<p>Set Delimiter Character</p> <p>The delimiter character is a two-digit hex value used as a parameter place marker in ZPL/ZPL II format instructions. See the ZPL Programming Guide for more information.</p> <p> Note - Do not use the same hex value for the control, format, and delimiter character. The printer must see different characters to work properly.</p> <p>Default Value: 2C , Range: 00 to FF</p> <p>To change the value shown:</p> <ol style="list-style-type: none"> 1. Press SELECT to select the parameter. 2. Press MINUS (-) to move to the next digit position. 3. Press PLUS (+) to increase the value of the digit. 4. Press SELECT to accept any changes and deselect the parameter.
ZPL and XML only 	<p>Select ZPL Mode</p> <p>The printer remains in the selected mode until it is changed by this parameter or by using a ZPL/ZPL II command. The printer accepts label formats written in either ZPL or ZPL II, eliminating the need to rewrite any ZPL formats that already exist. See the ZPL Programming Guide for more information on the differences between ZPL and ZPL II.</p> <p>Default Value: ZPL II Range: ZPL II, ZPL</p> <p>To change the value shown:</p> <ol style="list-style-type: none"> 1. Press SELECT to select the parameter. 2. Press PLUS (+) or MINUS (-) to toggle between the options. 3. Press SELECT to accept any changes and deselect the parameter.

Table 12 • Printer Parameters (Page 21 of 26)

Parameter	Action/Explanation
	<p>Select Media Power-Up Option</p> <p>This parameter sets the action of the media when you turn on the printer.</p> <p>Default Value: CALIBRATION</p> <p>Selections: CALIBRATION, SHORT CAL, LENGTH, NO MOTION, FEED</p> <ul style="list-style-type: none"> • Calibration adjusts sensor levels and thresholds, determines length, and feeds the media to the next web. • Short Cal sets media and web thresholds without adjusting sensor gain, determines length, and feeds the media to the next web. • Length determines label length using current sensor values, and feeds the media to the next web. • No Motion tells the printer not to move the media. You must manually ensure that the web is positioned correctly, or press feed to position the next web. • Feed—feeds the labels to the first registration point. <p>To change the value shown:</p> <ol style="list-style-type: none"> 1. Press SELECT to select the parameter. 2. Press PLUS (+) or MINUS (-) to scroll through the options. 3. Press SELECT to accept any changes and deselect the parameter.
	<p>Select Head Close Option</p> <p>This parameter sets the action of the media when you close the printhead.</p> <p>Default Value: CALIBRATION</p> <p>Selections: CALIBRATION, SHORT CAL, LENGTH, NO MOTION, FEED</p> <ul style="list-style-type: none"> • Calibration adjusts sensor levels and thresholds, determines length, and feeds the media to the next web. • Short Cal sets media and web thresholds without adjusting sensor gain, determines length, and feeds the media to the next web. • Length determines label length using current sensor values, and feeds the media to the next web. • No Motion tells the printer not to move the media. You must manually ensure that the web is positioned correctly, or press feed to position the next web. • Feed—feeds the labels to the first registration point. <p>To change the value shown:</p> <ol style="list-style-type: none"> 1. Press SELECT to select the parameter. 2. Press PLUS (+) or MINUS (-) to scroll through the options. 3. Press SELECT to accept any changes and deselect the parameter.

Table 12 • Printer Parameters (Page 22 of 26)



Parameter	Action/Explanation
	<p>Select Backfeed Sequence</p> <p>This parameter sets when label backfeed occurs after a label is removed in some print modes. It has no effect in Rewind mode. This setting is superseded by ~JS when received as part of a label format (see the ZPL Programming Guide for more information).</p> <p>Default Value: DEFAULT (90%)</p> <p>Selections: DEFAULT, AFTER, OFF, BEFORE, 10%, 20%, 30%, 40%, 50%, 60%, 70%, 80%</p> <p>To change the value shown:</p> <ol style="list-style-type: none"> 1. Press SELECT to select the parameter. 2. Press PLUS (+) or MINUS (-) to scroll through the options. 3. Press SELECT to accept any changes and deselect the parameter.
<p>ZPL, XML, EPL, APL-D</p> 	<p>Adjust Label Top Position</p> <p>This parameter adjusts the print position vertically on the label. Positive numbers adjust the label top position farther down the label (away from the printhead) by the specified number of dots. Negative numbers adjust the position up the label (toward the printhead).</p> <p>Default Value: +000</p> <p>Range (ZPL, XML, EPL): -120 to +120</p> <p>Range (APL-D): -0.64i to 0.64i (when printer is set to operate in inches)</p> <p>Range (APL-I): -10 to 4000</p> <p>To change the value shown:</p> <ol style="list-style-type: none"> 1. Press SELECT to select the parameter. 2. Press PLUS (+) to increase the value. 3. Press MINUS (-) to decrease the value. 4. Press SELECT to accept any changes and deselect the parameter.
<p>APL-I only</p> 	<p>Adjust Label Top Position</p> <p>This parameter adjusts the print position vertically on the label. Positive numbers adjust the label top position farther down the label (away from the printhead) by the specified number of dots. Negative numbers adjust the position up the label (toward the printhead).</p> <p>Default Value: +000</p> <p>Range (ZPL, XML, EPL): -120 to +120</p> <p>Range (APL-D): -0.64i to 0.64i (when printer is set to operate in inches)</p> <p>Range (APL-I): -10 to 4000</p> <p>To change the value shown:</p> <ol style="list-style-type: none"> 1. Press SELECT to select the parameter. 2. Press PLUS (+) to increase the value. 3. Press MINUS (-) to decrease the value. 4. Press SELECT to accept any changes and deselect the parameter.
<p>APL-I only</p> 	<p>Adjust Label Left Position</p> <p>The label left position adjusts the print position horizontally on the label. Positive numbers move the left edge of the image toward the center of the label by the number of dots selected while negative numbers shift the left edge of the image toward the left edge of the label.</p> <p>Default Value: +0000</p> <p>Range: -9999 to +9999</p> <p>To change the value shown:</p> <ol style="list-style-type: none"> 1. Press SELECT to select the parameter. 2. Press PLUS (+) to increase the value. 3. Press MINUS (-) to decrease the value. 4. Press SELECT to accept any changes and deselect the parameter.

Table 12 • Printer Parameters (Page 23 of 26)

Parameter	Action/Explanation
	<p>Adjust Left Position</p> <p>This parameter adjusts the print position horizontally on the label. Positive numbers adjust printing to the left by the specified number of dots. Negative numbers shift printing to the right.</p> <p>Default Value: 0000</p> <p>Range: -9999 to +9999 dots</p> <p>To change the value shown:</p> <ol style="list-style-type: none"> 1. Press SELECT to select the parameter. 2. Press MINUS (-) to move the cursor. 3. Press PLUS (+) to change between +/- and to increase the value of the digit. For a negative value, enter the value before changing to the minus sign. 4. Press SELECT to accept any changes and deselect the parameter.
<p>ZPL and XML only</p> 	<p>Set Reprint Mode</p> <p>When reprint mode is enabled, you can reprint the last label printed either by issuing the ~PR ZPL command or by pressing MINUS (-) on the control panel.</p> <p>Default Value: DISABLED</p> <p>Selections: ENABLED, DISABLED</p> <p>To change the value shown:</p> <ol style="list-style-type: none"> 1. Press SELECT to select the parameter. 2. Press PLUS (+) or MINUS (-) to toggle between the options. 3. Press SELECT to accept any changes and deselect the parameter.

Table 12 • Printer Parameters (Page 24 of 26)

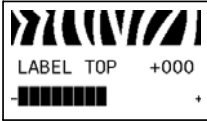





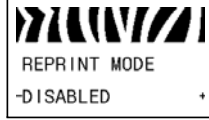

Parameter	Action/Explanation
See next column	<p>View Sensor Settings</p> <p>These parameters are automatically set during the calibration procedure and should be changed only by a qualified service technician. Refer to the ZPL II Programming Guide for information on these parameters.</p> <p>To skip these parameters:</p> <ol style="list-style-type: none"> 1. Press PLUS (+) to skip each of the following parameters: <div style="display: flex; flex-wrap: wrap;"> <div style="width: 50%; text-align: center;">  </div> <div style="width: 50%; text-align: center;">  </div> <div style="width: 50%; text-align: center;">  </div> <div style="width: 50%; text-align: center;">  </div> <div style="width: 50%; text-align: center;">  </div> <div style="width: 50%; text-align: center;">  </div> <div style="width: 50%; text-align: center;">  </div> <div style="width: 50%; text-align: center;">  </div> <div style="width: 50%; text-align: center;">  </div> <div style="width: 50%; text-align: center;">  </div> </div>
ZPL and XML only	<p>Select Format Convert</p> <p>Selects the bitmap scaling factor. The first number is the original dots per inch (dpi) value; the second, the dpi to which you would like to scale.</p> <p>Default Value: NONE</p> <p>Selections: NONE, 150 → 300, 150 → 600, 200 → 600, 300 → 600</p> <p>To change the value shown:</p> <ol style="list-style-type: none"> 1. Press SELECT to select the parameter. 2. Press PLUS (+) or MINUS (-) to scroll through the options. 3. Press SELECT to accept any changes and deselect the parameter.

Table 12 • Printer Parameters (Page 25 of 26)







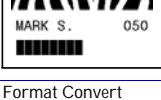
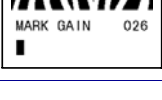







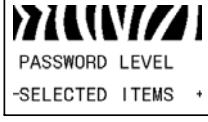

































Parameter	Action/Explanation
	<p>Select Idle Display</p> <p>This parameter selects the LCD options for the real-time clock.</p> <p> Note • If the default value is not selected, pressing PLUS (+) or MINUS (-) briefly displays the firmware version of the printer.</p> <p>Default Value: FIRMWARE (FW) VERSION</p> <p>Selections: MM/DD/YY (24HR), MM/DD/YY (12HR), DD/MM/YY (24HR), DD/MM/YY (12HR), FW VERSION</p> <p>To change the value shown:</p> <ol style="list-style-type: none"> 1. Press SELECT to select the parameter. 2. Press PLUS (+) or MINUS (-) to scroll through the options. 3. Press SELECT to accept any changes and deselect the parameter.
	<p>Set Real-Time Clock (RTC) Date</p> <p>This parameter allows you to set the date following the convention selected in IDLE DISPLAY.</p> <p>To change the value shown:</p> <ol style="list-style-type: none"> 1. Press SELECT to select the parameter. 2. Press MINUS (-) to move to the next digit position. 3. Press PLUS (+) to change the value of the digit. 4. Press SELECT to accept any changes and deselect the parameter.
	<p>Set RTC Time</p> <p>This parameter allows you to set the time following the convention selected in IDLE DISPLAY.</p> <p>To change the value shown:</p> <ol style="list-style-type: none"> 1. Press SELECT to select the parameter. 2. Press the left oval MINUS (-) to move to the next digit position. 3. Press the right oval PLUS (+) to change the value of the digit. 4. Press SELECT to accept any changes and deselect the parameter.
	<p>Specify Password Level</p> <p>This parameter allows you to select whether certain factory-selected menu items or all menu items are password protected.</p> <p>Default Value: SELECTED ITEMS</p> <p>Selections: SELECTED ITEMS, ALL ITEMS</p> <ol style="list-style-type: none"> 1. Press SELECT to select the parameter. 2. Press PLUS (+) or MINUS (-) to toggle between the options. 3. Press SELECT to accept any changes and deselect the parameter.

Table 12 • Printer Parameters (Page 26 of 26)

Parameter	Action/Explanation												
 LANGUAGE ENGLISH	Select the Display Language This parameter changes the language displayed on the LCD. Each language selection is displayed in the language itself. Default Value: ENGLISH Selections: ENGLISH, SPANISH, FRENCH, GERMAN, ITALIAN, NORWEGIAN, PORTUGUESE, SWEDISH, DANISH, SPANISH 2, DUTCH, FINNISH, JAPANESE, KOREAN, SIMPLIFIED CHINESE, TRADITIONAL CHINESE												
 LANGUAGE -ENGLISH +	<table border="1"> <tbody> <tr> <td>  IDIOMA -PORTUGUES + </td> <td>  言語 -日本 + </td> </tr> <tr> <td>  IDIOMA -ESPANOL + </td> <td>  SPRÅK -SVENSKA + </td> </tr> <tr> <td>  LANGAGE -FRANCAIS + </td> <td>  SPROG -DANSK + </td> </tr> <tr> <td>  Sprache -Deutsch + </td> <td>  IDIOMA -ESPANOL2 + </td> </tr> <tr> <td>  LINGUA -ITALIANO + </td> <td>  TAAL -NEDERLANDS + </td> </tr> <tr> <td>  SPRÅK -NORSK + </td> <td>  KIELI -SUOMI + </td> </tr> </tbody> </table>	 IDIOMA -PORTUGUES +	 言語 -日本 +	 IDIOMA -ESPANOL +	 SPRÅK -SVENSKA +	 LANGAGE -FRANCAIS +	 SPROG -DANSK +	 Sprache -Deutsch +	 IDIOMA -ESPANOL2 +	 LINGUA -ITALIANO +	 TAAL -NEDERLANDS +	 SPRÅK -NORSK +	 KIELI -SUOMI +
 IDIOMA -PORTUGUES +		 言語 -日本 +											
 IDIOMA -ESPANOL +		 SPRÅK -SVENSKA +											
 LANGAGE -FRANCAIS +		 SPROG -DANSK +											
 Sprache -Deutsch +		 IDIOMA -ESPANOL2 +											
 LINGUA -ITALIANO +		 TAAL -NEDERLANDS +											
 SPRÅK -NORSK +		 KIELI -SUOMI +											
 IDIOMA -ESPANOL +													
 LANGAGE -FRANCAIS +													
 Sprache -Deutsch +													
 LINGUA -ITALIANO +													
 SPRÅK -NORSK +													



Notes • _____

5



Routine Maintenance

This section provides routine cleaning and maintenance procedures.

Contents

Replacing Printer Components	98
Ordering Replacement Parts	98
Recycling Printer Components	98
Lubrication	98
Cleaning Schedule and Procedures.....	99
Clean the Exterior	99
Clean the Printhead and Platen Roller.....	100
Clean the Media Compartment and Sensors.....	103
Clean the Cutter Module	104
Routine Maintenance for the Rewind Option	106
Remove Printed Labels or Liner from the Rewind Spindle	106
Adjust Media Alignment for Rewind Option	108

Replacing Printer Components

Some printer components, such as the printhead and platen roller, may wear out over time and can be replaced easily. Regular cleaning may extend the life of some of these components. See [Cleaning Schedule and Procedures on page 99](#) for the recommended cleaning intervals.

Ordering Replacement Parts

For optimal printing quality and proper printer performance across our product line, Zebra strongly recommends the use of genuine Zebra™ supplies as part of the total solution. Specifically, the ZM400 and ZM600 are designed to work only with genuine Zebra™ printheads, thus maximizing safety and print quality.

Contact your authorized Zebra reseller for part ordering information, or see [Contacts on page 11](#) for contact addresses and telephone numbers.

Recycling Printer Components



The majority of this printer's components are recyclable. The printer's main logic board includes a battery that you should dispose of properly.

Do not dispose of any printer components in unsorted municipal waste. Please dispose of the battery according to your local regulations, and recycle the other printer components according to your local standards. For more information, see <http://www.zebra.com/environment>.

Lubrication

No lubrication is needed for this printer.

Caution • Some commercially available lubricants will damage the finish and the mechanical parts if used on this printer.

Cleaning Schedule and Procedures



Important • Zebra is not responsible for damage caused by the use of cleaning fluids on this printer.

Specific cleaning procedures are provided on the following pages. [Table 14](#) shows the recommended cleaning schedule. These intervals are intended as guidelines only. You may have to clean more often, depending upon your application and media.

Table 14 • Recommended Cleaning Schedule

Area	Method	Interval
Printhead	Solvent*	Direct Thermal Mode: After every roll of media (or 500 feet of fanfold media). Thermal Transfer Mode: After every roll of ribbon or three rolls of media.
Platen roller	Solvent*	
Media sensors	Air blow	
Ribbon sensor	Air blow	
Media path	Solvent*	
Ribbon path	Solvent*	
Pinch roller (part of Peel-Off option)	Solvent*	
Cutter module	If cutting continuous, pressure-sensitive media	After every roll of media (or more often, depending upon your application and media).
	If cutting tag stock or label liner material	Solvent* and air blow
Tear-off/peel-off bar	Solvent*	Once a month.
Take-label sensor	Air blow	Once every six months.

* Zebra recommends using Preventive Maintenance Kit (part number 47362). In place of this kit, you may use a clean swab dipped in a solution of isopropyl alcohol (minimum 90%) and deionized water (maximum 10%).

Clean the Exterior

You may clean the exterior surfaces of the printer with a lint-free cloth and a small amount of a mild detergent, if necessary. Do not use harsh or abrasive cleaning agents or solvents.

Clean the Printhead and Platen Roller

You can minimize printhead wear and maintain print quality with regular preventive measures. Over time, the movement of media or ribbon across the printhead wears through the protective ceramic coating, exposing and eventually damaging the print elements (dots). To avoid abrasion:

- Clean the printhead frequently, and use well-lubricated thermal transfer ribbons with backings optimized to reduce friction.
- Minimize printhead pressure and burn temperature settings by optimizing the balance between the two.
- Ensure that the thermal transfer ribbon is as wide or wider than the label media to prevent exposing the elements to the more abrasive label material.

For best results, clean the printhead after changing every roll of ribbon. Inconsistent print quality, such as voids in the bar code or graphics, may indicate a dirty printhead.

Caution • While performing any tasks near an open printhead, remove all rings, watches, hanging necklaces, identification badges, or other metallic objects that could touch the printhead. You are not required to turn off the printer power when working near an open printhead, but Zebra recommends it as a precaution. If you turn off the power, you will lose all temporary settings, such as label formats, and you must reload them before you resume printing.



Note • For printers with a peel assembly, keep the peel assembly closed while cleaning the platen roller to reduce the risk of bending the tear-off/peel-off bar.

Figure 15 • Location of the Printhead and Platen Roller

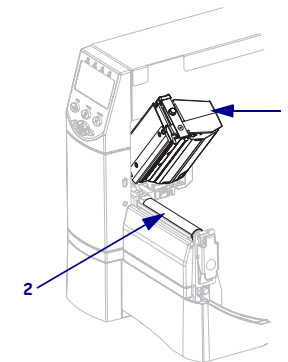

1	Printhead assembly
2	Platen roller



Caution • The printhead may be hot and could cause severe burns. Allow the printhead to cool.



Caution • Before touching the printhead assembly, discharge any built-up static electricity by touching the metal printer frame or by using an antistatic wriststrap and mat.

To clean the printhead and platen roller, complete these steps:

1. Open the printhead assembly.
2. Remove the media and ribbon.
3. Using the swab from the Preventive Maintenance Kit (part number 47362), wipe along the brown strip on the printhead assembly from end to end. In place of the Preventive Maintenance Kit, you may use a clean swab dipped in a solution of isopropyl alcohol (minimum 90%) and deionized water (maximum 10%). Allow the solvent to evaporate.

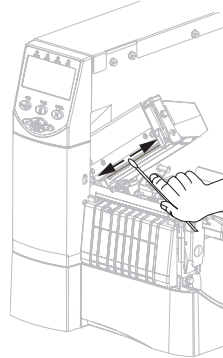

4. While manually rotating the platen roller, clean it thoroughly with the swab. Allow the solvent to evaporate.

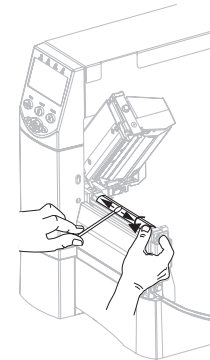

5. Reload media and ribbon, and close the printhead assembly.



Note • If performing this procedure does not improve print quality, try cleaning the printhead with Save-A-Printhead cleaning film. This specially coated material removes contamination buildup without damaging the printhead. Call your authorized Zebra reseller for more information.

Clean the Media Compartment and Sensors

To clean the media compartment and sensors, complete these steps:

1. Brush or vacuum any accumulated paper lint and dust away from the media and ribbon paths.
2. Brush or vacuum any paper lint and dust away from the sensors (see [Figure 16](#)).

Figure 16 • Cleaning the Sensors

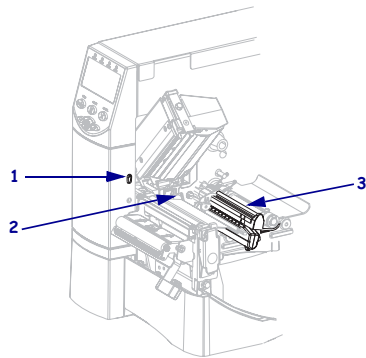

1	Take-label sensor
2	Ribbon sensor
3	Media sensor

Clean the Cutter Module

If the cutter is not cutting the labels cleanly or if it jams with labels, clean the cutter.



Caution • For personnel safety, always power off and unplug the printer before performing this procedure.

To clean the cutter module, complete these steps:

1. Turn the printer off (O), and unplug the printer from its power source.
2. Caution • The cutter blade is sharp. Do not touch or rub the blade with your fingers.



Remove the cutter shield (1) by removing the cutter shield thumbscrew and lock washer (2).

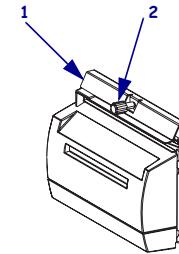

3. To expose the V-shaped cutter blade, turn the cutter motor thumbscrew (1) counterclockwise to lower the blade.

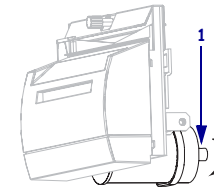

- See **Figure 17**. Using the swab from the Preventive Maintenance Kit (part number 47362), wipe along the upper cutting surface (1) and the cutter blade (2). In place of the Preventive Maintenance Kit, you may use a clean swab dipped in a solution of isopropyl alcohol (minimum 90%) and deionized water (maximum 10%). Allow the solvent to evaporate.

Figure 17 • Cleaning the Cutter Module

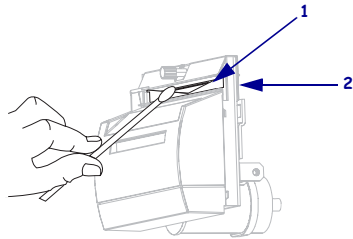

- Replace the cutter shield.
- Plug the printer into its power source, and then turn on (I) the printer. The lower cutter blade returns to its correct operating position.
- If the cutter continues to perform unsatisfactorily, contact an authorized service technician.

Routine Maintenance for the Rewind Option

When you use the Rewind option, you will periodically need to remove printed labels or used liner from the rewind spindle. You may also need to adjust the media alignment for the Rewind option.

Remove Printed Labels or Liner from the Rewind Spindle

To remove printed labels or liner from the rewind spindle, complete these steps:

- Cut the liner between the media alignment spindle and the rewind spindle.

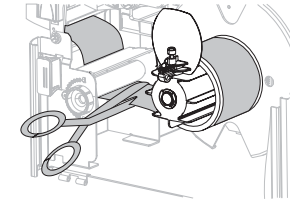

- Rotate the take-up spindle counterclockwise until the rewind media guide is fully upright.

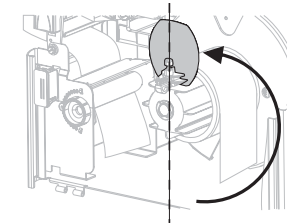

- Loosen the thumbscrew on the rewind media guide.

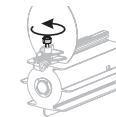

4. Slide the rewind media guide all the way out, and then fold it down.

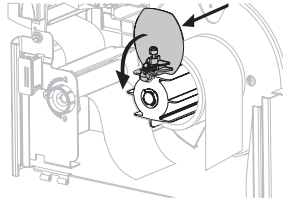

5. Slide the core with the liner from the take-up spindle.

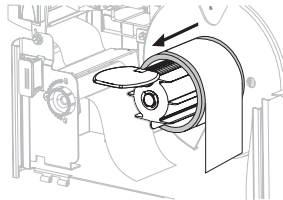

Adjust Media Alignment for Rewind Option

The instructions below apply only if the printer has a Rewind option. The liner should be installed flush against the backplate of the rewind spindle to prevent the media/backing from winding too loosely.

Perform the adjustments in the order given. Do only what is needed to solve the problem.

To adjust the media alignment for printers with the Rewind option, complete these steps:

1. Turn the adjustment dial (1) clockwise to move the media toward the backplate (2).

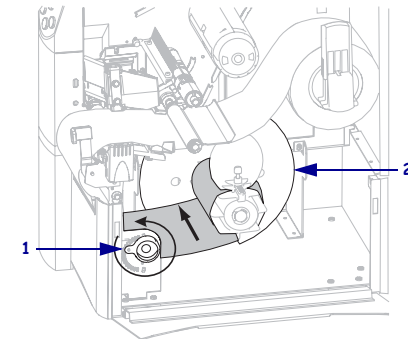

2. Turn the adjustment dial (1) counter clockwise to move the media away from the backplate (2).

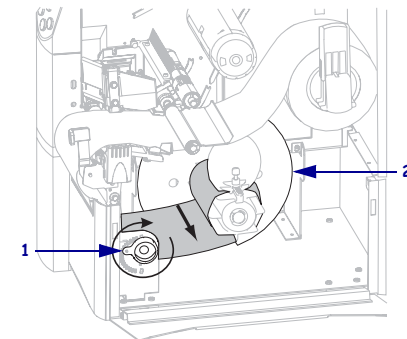



Troubleshooting

This section provides information about errors that you might need to troubleshoot. Assorted diagnostic tests are included.

Contents

Troubleshooting Checklists	110
LCD Error Messages	111
Print Quality Problems	115
Calibration Problems	118
Communications Problems	119
Ribbon Problems	120
Miscellaneous Printer Problems	121
Printer Diagnostics	123
Power-On Self Test	123
CANCEL Self Test	124
PAUSE Self Test	125
FEED Self Test	126
FEED and PAUSE Self Test	129
Communications Diagnostics Test	130
Sensor Profile	131

Troubleshooting Checklists

If an error condition exists with the printer, review this checklist:

- Are noncontinuous labels being treated as continuous labels? If yes, see [Calibrate Media and Ribbon Sensor Sensitivity on page 84](#).
- Is the printer reporting a ribbon error when ribbon is loaded properly? If yes, see [Calibrate Media and Ribbon Sensor Sensitivity on page 84](#).
- Are you experiencing problems with print quality? If yes, see [Print Quality Problems on page 115](#).
- Are you experiencing communications problems? If yes, see [Communications Problems on page 119](#).

If the labels are not printing or advancing correctly, review this checklist:

- Are you using the correct type of labels? Review the types of label in [Types of Media on page 33](#).
- Are you using a label that is narrower than the maximum print width? See [Set Print Width on page 75](#).
- Review the label- and ribbon-loading illustrations in [Load Media on page 41](#) and [Load Ribbon on page 55](#).
- Does the printhead need to be adjusted? See [Adjust Printhead Pressure on page 61](#) for more information.
- Do the sensors need to be calibrated? See [Calibrate Media and Ribbon Sensor Sensitivity on page 84](#) for more information.

If none of the above suggestions correct the problem, review this checklist:

- Perform one or more of the self-tests given in [Printer Diagnostics on page 123](#). Use the results to help identify the problem.
- If you are still having problems, see [Contacts on page 11](#) for customer support information.

LCD Error Messages

The LCD displays messages when there is an error. See [Table 15](#) for LCD errors, the possible causes, and the recommended solutions.

Table 15 • LCD Error Messages

LCD Display/ Printer Condition	Possible Cause	Recommended Solution
ERROR CONDITION INVALID HEAD The ERROR light flashes.	The printhead was replaced with one that is not a genuine Zebra™ printhead.	Install a genuine Zebra™ printhead.
ERROR CONDITION RIBBON OUT The printer stops; the ERROR light flashes.	<p>In thermal transfer mode, ribbon is not loaded or incorrectly loaded.</p> <p>In thermal transfer mode, the ribbon sensor is not detecting ribbon that is loaded incorrectly.</p> <p>In thermal transfer mode, media is blocking the ribbon sensor.</p> <p>In thermal transfer mode, the printer did not detect the ribbon even though it is loaded correctly.</p>	<p>Load ribbon correctly. See Load Ribbon on page 55.</p> <ol style="list-style-type: none"> Load ribbon correctly. See Load Ribbon on page 55. Calibrate the sensors. See Calibrate Media and Ribbon Sensor Sensitivity on page 84. <ol style="list-style-type: none"> Load media correctly. See Load Media on page 41. Calibrate the sensors. See Calibrate Media and Ribbon Sensor Sensitivity on page 84. <ol style="list-style-type: none"> Print a sensor profile. See Print Sensor Profile on page 83. The ribbon out threshold (marked by the word RIBBON) is likely too high, above the black area that indicates where the ribbon is detected.  <ol style="list-style-type: none"> Calibrate the sensors or load printer defaults. See Calibrate Media and Ribbon Sensor Sensitivity on page 84 or LOAD DEFAULTS on page 65.

Table 15 • LCD Error Messages (Continued)

LCD Display/ Printer Condition	Possible Cause	Recommended Solution
WARNING RIBBON IN The ERROR light flashes.	Ribbon is loaded, but the printer is set for direct thermal mode.	<p>Ribbon is not required with direct thermal media. If you are using direct thermal media, remove the ribbon. This error message will not affect printing.</p> <p>If you are using thermal transfer media, which requires ribbon, set the printer for Thermal Transfer mode. See Select Print Method on page 75.</p>
ERROR CONDITION PAPER OUT The printer stops; the ERROR light flashes.	<p>The media is not loaded or is loaded incorrectly.</p> <p>Misaligned media sensor.</p>	<p>Load media correctly. See Load Media on page 41.</p> <p>Check position of the media sensor.</p>
ERROR CONDITION HEAD OPEN The printer stops; the ERROR light flashes.	<p>The printer is set for noncontinuous media, but continuous media is loaded.</p> <p>The printhead is not fully closed.</p> <p>The head open sensor is not working properly.</p>	<p>Install proper media type, or reset printer for current media type and perform calibration.</p> <p>Close printhead completely.</p> <p>Call a service technician.</p>
THERMISTOR FAULT The ERROR light flashes.	The printhead has a faulty thermistor.	Call a service technician.
WARNING HEAD COLD	 Caution • An improperly connected printhead data or power cable can cause these error messages. The printhead may be hot enough to cause severe burns. Allow the printhead to cool.	
THERMISTOR FAULT	The printhead data cable is not properly connected.	<p>Caution • Turn off (O) the printer before performing this procedure. Failure to do so can damage the printhead.</p> <ol style="list-style-type: none"> Turn off (O) the printer. Disconnect and reconnect the data cable to the printhead. Ensure that the cable connector is fully inserted into the printhead connector. Turn on (I) the printer.
ERROR CONDITION HEAD ELEMENT BAD The printer stops; the ERROR light is on; the printer cycles through these three messages.	The printhead has a faulty thermistor.	Call a service technician.

Table 15 • LCD Error Messages (Continued)

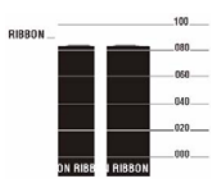

LCD Display/ Printer Condition	Possible Cause	Recommended Solution
<div style="border: 1px solid black; padding: 2px; display: inline-block;">WARNING HEAD COLD</div> The printer prints while the ERROR light flashes.	 Caution • An improperly connected printhead data or power cable can cause this error message. The printhead may be hot enough to cause severe burns. Allow the printhead to cool.	
	The printhead temperature is approaching its lower operating limit.	Continue printing while the printhead reaches the correct operating temperature. If the error remains, the environment may be too cold for proper printing. Relocate the printer to a warmer area.
	The printhead data cable is not properly connected.	Caution • Turn off (O) the printer before performing this procedure. Failure to do so can damage the printhead. <ol style="list-style-type: none"> 1. Turn off (O) the printer. 2. Disconnect and reconnect the data cable to the printhead. 3. Ensure that the cable connector is fully inserted into the printhead connector. 4. Turn on (I) the printer.
	The printhead has a faulty thermistor.	Call a service technician.
<div style="border: 1px solid black; padding: 2px; display: inline-block;">WARNING HEAD TOO HOT</div> The printer stops; the ERROR light flashes.	 Caution • The printhead may be hot enough to cause severe burns. Allow the printhead to cool.	
	The printhead is over temperature.	Allow the printer to cool. Printing automatically resumes when the printhead elements cool to an acceptable operating temperature.

Table 15 • LCD Error Messages (Continued)

LCD Display/ Printer Condition	Possible Cause	Recommended Solution
<div style="border: 1px solid black; padding: 2px; display: inline-block;">DEFRAGMENTING</div> The printer stops.	The printer is defragmenting memory.	Caution • Do NOT turn off the printer power during defragmenting. Doing so can damage the printer. Allow the printer to finish defragmenting. If you get this error message frequently, check your label formats. Formats that write to and erase memory frequently may cause the printer to defragment often. Using properly coded label formats usually minimizes the need for defragmenting. If this error message does not go away, contact Technical Support. The printer requires service.
<div style="border: 1px solid black; padding: 2px; display: inline-block;">ERROR CONDITION CUTTER JAM</div> The printer stops; the ERROR light flashes.	 Caution • The cutter blade is sharp. Do not touch or rub the blade with your fingers.	
	The cutter blade is in the media path.	Turn off the printer power and unplug the printer. Inspect the cutter module for debris and clean as needed following the cleaning instructions in Clean the Cutter Module on page 104 .
<div style="border: 1px solid black; padding: 2px; display: inline-block;">OUT OF MEMORY <function></div>	There is not enough memory to perform the function specified on the second line of the error message.	Free up some of the printer's memory by adjusting the label format or printer parameters. One way to free up memory is to adjust the print width to the actual width of the label instead of leaving the print width set to the default. See Set Print Width on page 75 . Ensure that the data is not directed to a device that is not installed or is unavailable. Refer to the Maintenance Manual for more information about the specified function.

Print Quality Problems

Table 16 identifies problems with print quality, the possible causes, and the recommended solutions.

Table 16 • Print Quality Problems

Problem	Possible Cause	Recommended Solution
General print quality issues	The printer is set at the incorrect print speed.	For optimal print quality, set the print speed to the lowest possible setting for your application via control panel, the driver, or the software. See Adjust Print Speed on page 71 . You may want to perform the FEED Self Test on page 126 .
	You are using an incorrect combination of labels and ribbon for your application.	<ol style="list-style-type: none"> Switch to a different type of media or ribbon to try to find a compatible combination. If necessary, consult your authorized Zebra reseller or distributor for information and advice.
	The printer is set at an incorrect darkness level.	For optimal print quality, set the darkness to the lowest possible setting for your application via the control panel, the driver, or the software. See Adjust Print Darkness/Density on page 70 . You may want to perform the FEED Self Test on page 126 to determine the ideal darkness setting.
	The printhead is dirty.	Clean the printhead. See Clean the Printhead and Platen Roller on page 100 .
	Incorrect or uneven printhead pressure.	Set the printhead pressure to the minimum needed for good print quality. See Adjust Printhead Pressure on page 61 .
	The printhead is improperly balanced.	Call a service technician.
	Print element damaged.	Call a service technician.
Long tracks of missing print on several labels	Print element damaged.	Call a service technician.

Table 16 • Print Quality Problems (Continued)

Problem	Possible Cause	Recommended Solution
Wrinkled ribbon	Ribbon was fed through the ribbon system incorrectly.	Load the ribbon correctly. See Load Ribbon on page 55 .
	Incorrect burn temperature.	Set the darkness to the lowest possible setting for good print quality. See Adjust Print Darkness/Density on page 70 .
	Incorrect or uneven printhead pressure.	Set the printhead pressure to the minimum needed for good print quality. See Adjust Printhead Pressure on page 61 .
	Media not feeding properly; "walking" from side to side.	Make sure that media is snug by adjusting the media guide, or call a service technician.
	The strip plate needs adjusting.	Call a service technician.
	The printhead needs vertical adjustment.	Call a service technician.
	The printhead is improperly balanced.	Call a service technician.
Printing too light or too dark over the entire label	The printhead and platen roller need to be realigned.	Call a service technician.
	The media or ribbon is not designed for high-speed operation.	Replace supplies with those recommended for high-speed operation.
	You are using an incorrect combination of media and ribbon for your application.	<ol style="list-style-type: none"> Switch to a different type of media or ribbon to try to find a compatible combination. If necessary, consult your authorized Zebra reseller or distributor for information and advice.
	You are using ribbon with direct thermal media.	Direct thermal media does not require ribbon. To check if you are using direct thermal media, perform the label scratch test in When to Use Ribbon on page 35 .
	Incorrect or uneven printhead pressure.	Set the pressure to the minimum needed. See Adjust Printhead Pressure on page 61 .
	The media or ribbon is not designed for high-speed operation.	Replace supplies with those recommended for high-speed operation.
	Smudge marks on labels	<p>The media or ribbon is not designed for high-speed operation.</p>
Misregistration/skips labels	The printer is not calibrated.	Recalibrate the printer.
	Improper label format.	Use correct label format.
Misregistration and misprint of one to three labels	The platen roller is dirty.	See Clean the Printhead and Platen Roller on page 100 .
	Media does not meet specifications.	Use media that meets specifications.

Table 16 • Print Quality Problems (Continued)

Problem	Possible Cause	Recommended Solution
Vertical drift in top-of-form position	The printer is out of calibration.	Recalibrate the printer.
	Vertical drift occurs during normal printer operation.  Note • A vertical drift of ± 4 to 6 dot rows (approximately 0.5 mm) is within normal tolerances.	Calibrate the printer.
	The platen roller is dirty.	Clean the platen roller. See Clean the Printhead and Platen Roller on page 100 .
Vertical image or label drift	The printer is using non-continuous labels but is configured in continuous mode.	Configure the printer for non-continuous and run calibration routine, if necessary.
	The media sensor is positioned incorrectly.	Ensure that the media sensor is properly positioned to read a single/consistent interlabel gap.
	The media sensor is calibrated improperly.	See Calibrate Media and Ribbon Sensor Sensitivity on page 84 .
	The platen roller is dirty.	Clean the platen roller. See Clean the Printhead and Platen Roller on page 100 .
	Improper printhead pressure settings (toggles).	Adjust the printhead pressure to ensure proper functionality.
	Improperly loaded ribbon or media.	Verify that the printer is loaded properly.
	Incompatible media.	Ensure that the interlabel gaps or notches are 2 to 4 mm and consistently placed. Media must not exceed minimum specifications for mode of operation.
The bar code printed on a label does not scan.	The bar code is not within specifications because the print is too light or too dark.	Perform the FEED Self Test on page 126 . Adjust the darkness or print speed settings as necessary.
	Not enough blank space around the bar code.	Leave at least 1/8 in. (3.2 mm) between the bar code and other printed areas on the label and between the bar code and the edge of the label.

Calibration Problems

Table 17 identifies problems with calibration, the possible causes, and the recommended solutions.

Table 17 • Calibration Problems

Problem	Possible Cause	Recommended Solution
Loss of printing registration on labels. Excessive vertical drift in top-of-form registration.	The platen roller is dirty.	Clean the platen roller according to the instructions in Clean the Printhead and Platen Roller on page 100 .
	Media guides are positioned improperly.	Ensure that the media guides are properly positioned.
	The media type is set incorrectly.	Set the printer for the correct media type (gap/notch, continuous, or mark). See Set Media Type on page 74 .
	The media is loaded incorrectly.	Load media correctly. See Load Media on page 41 .
Auto Calibrate failed.	Media or ribbon is loaded incorrectly.	Ensure that media and ribbon are loaded correctly.
	The sensors could not detect the media or ribbon.	Manually calibrate the printer. See Calibrate Media and Ribbon Sensor Sensitivity on page 84 .
	The sensors are dirty or positioned improperly. The sensors are dirty, or media is positioned improperly for the sensors to detect.	Ensure that the sensors are clean and that media is positioned properly.
	The media type is set incorrectly.	Set the printer for the correct media type (gap/notch, continuous, or mark). See Set Media Type on page 74 .

Communications Problems

Table 18 identifies problems with communications, the possible causes, and the recommended solutions.

Table 18 • Communications Problems

Problem	Possible Cause	Recommended Solution
A label format was sent to the printer but was not recognized. The DATA light does not flash.	The communication parameters are incorrect.	Check the printer driver or software communications settings (if applicable).
		If you are using serial communication, check the serial port setting in the control panel menu. See Set Serial Communications on page 85 .
		If you are using serial communication, make sure that you are using a null modem cable or a null modem adapter.
		Using the control panel controls, check the protocol setting. It should be set to NONE . See Set Protocol on page 87 .
		If a driver is used, check the driver communication settings for your connection.
A label format was sent to the printer. Several labels print, then the printer skips, misplaces, misses, or distorts the image on the label.	The serial communication settings are incorrect.	Ensure that the flow control settings match.
		Check the communication cable length. See Table 5 on page 27 for requirements.
		Check the printer driver or software communications settings (if applicable).
A label format was sent to the printer but was not recognized. The DATA light flashes but no printing occurs.	The prefix and delimiter characters set in the printer do not match the ones in the label format.	Verify the prefix and delimiter characters. See Set Format Prefix Character on page 88 and Set Delimiter Character on page 89 for the requirements.
	Incorrect data is being sent to the printer.	Check the communication settings on the computer. Ensure that they match the printer settings. If the problem continues, check the label format.

Ribbon Problems

Table 19 identifies problems that may occur with ribbon, the possible causes, and the recommended solutions.

Table 19 • Ribbon Problems

Problem	Possible Cause	Recommended Solution
Broken or melted ribbon	Darkness setting too high.	<ol style="list-style-type: none"> 1. Reduce the darkness setting. 2. Clean the printhead thoroughly.
The printer does not detect when the ribbon runs out.	The printer was calibrated without ribbon. Later, ribbon was inserted without the user recalibrating the printer or loading printer defaults.	Calibrate the printer, this time using ribbon, or load printer defaults. See Calibrate Media and Ribbon Sensor Sensitivity on page 84 .
In thermal transfer mode, the printer did not detect the ribbon even though it is loaded correctly.		
The ribbon light is on even though ribbon is loaded correctly.	The printer was not calibrated for the label and ribbon being used.	Perform the calibration procedure in Calibrate Media and Ribbon Sensor Sensitivity on page 84 .

Miscellaneous Printer Problems

Table 20 identifies miscellaneous problems with the printer, the possible causes, and the recommended solutions.

Table 20 • Miscellaneous Printer Problems

Problem	Possible Cause	Recommended Solution
The LCD displays a language that I cannot read	The language parameter was changed through the control panel or a firmware command.	<ol style="list-style-type: none"> Press SETUP/EXIT to enter configuration mode. Press MINUS (-). The printer displays the LANGUAGE parameter in the current language. Even if you cannot recognize the characters displayed, you can still scroll to another language. Press SELECT to select the parameter. Press PLUS (+) or MINUS (-) to scroll through the choices until you find a language that you can read. Press SETUP/EXIT. The LCD displays SAVE CHANGES in the original language. Press SETUP/EXIT again to exit configuration mode and save the changes (if the language does not change, you may need to scroll to a different save option by pressing PLUS (+) or MINUS (-) in the previous step). Repeat this process, if necessary, until you reach the desired language.
The LCD is missing characters or parts of characters	The LCD may need replacing.	Call a service technician.
Changes in parameter settings did not take effect	Parameters are set incorrectly.	<ol style="list-style-type: none"> Set parameters and save permanently. Turn the printer off (O) and then on (I).
	A command turned off the ability to change the parameter.	Refer to the ZPL Programming Guide, or call a service technician.
	A command changed the parameter back to the previous setting.	Refer to the ZPL Programming Guide, or call a service technician. Refer to the Programming Guide for the printer language being used, or call a service technician.
	If the problem continues, there may be a problem with the main logic board.	Call a service technician.

Table 20 • Miscellaneous Printer Problems (Continued)

Problem	Possible Cause	Recommended Solution
While in Peel-Off mode, media liner wraps around the platen roller.	You are using perforated media, which is not recommended for Peel-Off mode.	While operating in Peel-Off mode, use media that is not perforated.
The printer fails to calibrate or detect the top of the label.	The printer was not calibrated for the label being used.	Perform the calibration procedure in Calibrate Media and Ribbon Sensor Sensitivity on page 84 .
	The printer is configured for continuous media.	Set the media type to noncontinuous media. See Set Media Type on page 74 .
	The driver or software configuration is not set correctly.	Driver or software settings produce commands that can overwrite the printer configuration. Check the driver or software media-related setting.
Non-continuous labels are being treated as continuous labels.	The printer was not calibrated for the media being used.	Perform the calibration procedure in Calibrate Media and Ribbon Sensor Sensitivity on page 84 .
	The printer is configured for continuous media.	Set the media type to noncontinuous media. See Set Media Type on page 74 .
All lights are on, but nothing displays on the LCD, and the printer locks up.	Internal electronic or firmware failure.	Call a service technician.
The printer locks up while running the Power-On Self Test.	Main logic board failure.	Call a service technician.
The printer prints VOID on every label that I try to print.	The printer is set for RFID operation, but you are not using RFID labels.	Switch to RFID labels, or remove the RFID commands from your label formats.

Printer Diagnostics

Self tests and other diagnostics provide specific information about the condition of the printer. The self tests produce sample printouts and provide specific information that helps determine the operating conditions for the printer. The most commonly used are the Power-On and the CANCEL self tests.



Important • Use full-width media when performing self tests. If your media is not wide enough, the test labels may print on the platen roller. To prevent this from happening, check the print width using [Set Print Width on page 75](#), and ensure that the width is correct for the media that you are using.

Each self test is enabled by pressing a specific control panel key or combination of keys while turning on (I) the printer power. Keep the key(s) pressed until the first indicator light turns off. The selected self test automatically starts at the end of the Power-On Self Test.



Note •

- When performing these self tests, do not send data to the printer from the host.
- If your media is shorter than the label to be printed, the test label continues on the next label.
- When canceling a self test prior to its actual completion, always reset the printer by turning it off (O) and then on (I).

Power-On Self Test

A Power-On Self Test (POST) is performed each time the printer is turned on (I). During this test, the control panel lights (LEDs) turn on and off to ensure proper operation. At the end of this self test, only the POWER LED remains lit. When the Power-On Self Test is complete, the media is advanced to the proper position.

To initiate the Power-On Self Test, complete these steps:

1. Turn on (I) the printer.

The POWER LED illuminates. The other control panel LEDs and the LCD monitor the progress and indicate the results of the individual tests. All messages during the POST display in English; however, if the test fails, the resulting messages cycle through the international languages as well.

CANCEL Self Test

The CANCEL self test prints a configuration label ([Figure 18](#)).

To perform the CANCEL Self Test, complete these steps:

1. Turn off (O) the printer.
2. Press and hold CANCEL while turning on (I) the printer. Hold CANCEL until the first control panel light turns off.

A printer configuration label prints ([Figure 18](#)).

Figure 18 • Configuration Label

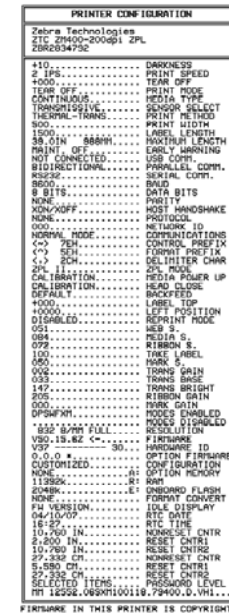

PAUSE Self Test

This self test can be used to provide the test labels required when making adjustments to the printer's mechanical assemblies or to determine if any printhead elements are not working. [Figure 19](#) shows a sample printout.

To perform a PAUSE self test, complete these steps:

1. Turn off (O) the printer.
2. Press and hold PAUSE while turning on (I) the printer. Hold PAUSE until the first control panel light turns off.
 - The initial self test prints 15 labels at the printer's slowest speed, and then automatically pauses the printer. Each time PAUSE is pressed, an additional 15 labels print. [Figure 19](#) shows a sample of the labels.

Figure 19 • PAUSE Test Label



- While the printer is paused, pressing CANCEL alters the self test. Each time PAUSE is pressed, 15 labels print at 6 in. (152 mm) per second.
- While the printer is paused, pressing CANCEL again alters the self test a second time. Each time PAUSE is pressed, 50 labels print at the printer's slowest speed
- While the printer is paused, pressing CANCEL again alters the self test a third time. Each time PAUSE is pressed, 50 labels print at 6 in. (152 mm) per second.
- While the printer is paused, pressing CANCEL again alters the self test a fourth time. Each time PAUSE is pressed, 15 labels print at the printer's maximum speed.
- To exit this self test at any time, press and hold CANCEL.

FEED Self Test

Different types of media may require different darkness settings. This section contains a simple but effective method for determining the ideal darkness for printing bar codes that are within specifications.

During the FEED self test, labels are printed at different darkness settings at two different print speeds. The relative darkness and the print speed are printed on each label. The bar codes on these labels may be ANSI-graded to check print quality.

The darkness value starts at three settings lower than the printer's current darkness value (relative darkness of -3) and increase until the darkness is three settings higher than the current darkness value (relative darkness of +3).

Depending on the dot density of the printhead, seven labels are printed at each of the following speeds:

- 203 dpi printers: 2 ips, 6 ips, and 10 ips
- 300 dpi printers: 2 ips, 6 ips, 8 ips
- 600 dpi printers: 2 ips, 4 ips

To perform a FEED self test, complete these steps:

1. Print a configuration label to show the printer's current settings.
2. Turn off (O) the printer.
3. Press and hold FEED while turning on (I) the printer. Hold FEED until the first control panel light turns off.

The printer prints a series of labels ([Figure 20](#)) at various speeds and at darkness settings higher and lower than the darkness value shown on the configuration label.

Figure 20 • FEED Test Label



- See [Figure 21](#) and [Table 21](#). Inspect the test labels and determine which one has the best print quality for your application. If you have a bar code verifier, use it to measure bars/spaces and calculate the print contrast. If you do not have a bar code verifier, use your eyes or the system scanner to choose the optimal darkness setting based on the labels printed in this self test.

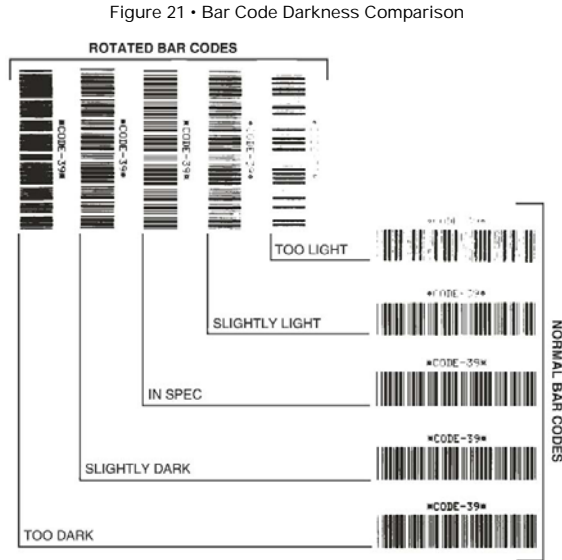

Table 21 • Judging Bar Code Quality

Print Quality	Description
Too dark	Labels that are too dark are fairly obvious. They may be readable but not “in-spec.” <ul style="list-style-type: none"> The normal bar code bars increase in size. The openings in small alphanumeric characters may fill in with ink. Rotated bar code bars and spaces run together.
Slightly dark	Slightly dark labels are not as obvious. <ul style="list-style-type: none"> The normal bar code will be “in-spec.” Small character alpha numerics will be bold and could be slightly filled in. The rotated bar code spaces are small when compared to the “in-spec” code, possibly making the code unreadable.
“In-spec”	The “in-spec” bar code can only be confirmed by a verifier, but it should exhibit some visible characteristics. <ul style="list-style-type: none"> The normal bar code will have complete, even bars and clear, distinct spaces. The rotated bar code will have complete, even bars and clear, distinct spaces. Although it may not look as good as a slightly dark bar code, the bar code will be “in-spec.” In both normal and rotated styles, small alphanumeric characters look complete.
Slightly light	Slightly light labels are, in some cases, preferred to slightly dark ones for “in-spec” bar codes. <ul style="list-style-type: none"> Both normal and rotated bar codes will be in spec, but small alphanumeric characters may not be complete.
Too light	Labels that are too light are obvious. <ul style="list-style-type: none"> Both normal and rotated bar codes have incomplete bars and spaces. Small alphanumeric characters are unreadable.

- Note the relative darkness value and the print speed printed on the best test label.
- Add or subtract the relative darkness value from the darkness value specified on the configuration label. The resulting numeric value is the best darkness value for that specific label/ribbon combination and print speed.
- If necessary, change the darkness value to the darkness value on the best test label. See [Adjust Print Darkness/Density on page 70](#).
- If necessary, change the print speed to the same speed as on the best test label. See [Adjust Print Speed on page 71](#).

FEED and PAUSE Self Test

Performing this self test temporarily resets the printer configuration to the factory default values. These values are active only until power is turned off unless you save them permanently in memory. If the factory default values are permanently saved, a media calibration procedure must be performed.

To perform a FEED and PAUSE self test, complete these steps:

1. Turn off (O) the printer.
2. Press and hold FEED and PAUSE while turning on (I) the printer.
3. Hold FEED and PAUSE until the first control panel light turns off.

The printer configuration is temporarily reset to the factory default values. No labels print at the end of this test.

Communications Diagnostics Test

The communication diagnostics test is a troubleshooting tool for checking the interconnection between the printer and the host computer.

When the printer is in diagnostics mode, it prints all data received from the host computer as straight ASCII characters with the hex values below the ASCII text. The printer prints all characters received, including control codes such as CR (carriage return). [Figure 22](#) shows a typical test label from this test.



Note • The test label prints upside-down.

Figure 22 • Communications Diagnostics Test Label

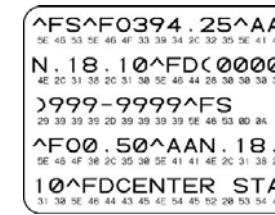

To use communications diagnostics mode, complete these steps:

1. Set the print width equal to or less than the label width being used for the test. See [Set Print Width on page 75](#) for more information.
2. Set the printer to **DIAGNOSTICS**. For instructions, see [Set Communications Mode on page 88](#).
The printer enters diagnostics mode and prints any data received from the host computer on a test label.
3. Check the test label for error codes. For any errors, check that your communication parameters are correct.
Errors show on the test label as follows:
 - FE indicates a framing error.
 - OE indicates an overrun error.
 - PE indicates a parity error.
 - NE indicates noise.
4. Turn the printer off (O) and then back on (I) to exit this self test and return to normal operation.

Sensor Profile

Use the sensor profile label to troubleshoot the following types of problems:

- If the media sensor experiences difficulty in determining gaps (web) between labels.
- If the media sensor incorrectly identifies preprinted areas on a label as gaps (web).
- If the ribbon sensor cannot detect ribbon.

For instructions on printing a sensor profile, see [Print Sensor Profile on page 83](#). If the sensitivity of the sensors must be adjusted, perform [Calibrate Media and Ribbon Sensor Sensitivity on page 84](#).

Ribbon Sensor Profile ([Figure 23](#)) The bars (1) on the sensor profile indicate the ribbon sensor readings. The ribbon sensor threshold setting is indicated by the word RIBBON (2). If the ribbon readings are below the threshold value, the printer does not acknowledge that ribbon is loaded.

Figure 23 • Sensor Profile (Ribbon Section)

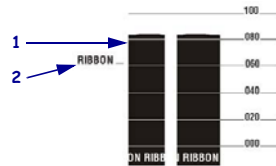

Media Sensor Profile ([Figure 24](#)) The media sensor readings are shown as bars and flat areas on the sensor profile. The bars (1) indicate gaps between labels (the web), and the low areas (2) indicate where labels are located. If you compare the sensor profile printout to a blank length of your media, the bars should be the same distance apart as the gaps on the media. If the distances are not the same, the printer may be having difficulty determining where the gaps are located.

The media sensor threshold settings are shown by the words MEDIA (3) for the media threshold and WEB (4) for the web threshold. Use the numbers to the left of the sensor readings to compare the numeric readings to the sensor settings.

Figure 24 • Sensor Profile (Media Section)

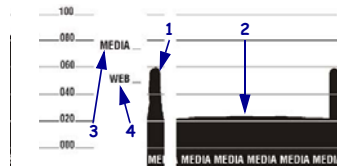

Notes • _____

7



Specifications

This section provides the features of and specifications for the printer.

Contents

General Specifications	134
Printing Specifications	135
Media Specifications	137
Ribbon Specifications	138
Printer Options	139

General Specifications

General Specifications		ZM400/RZ400		ZM600/RZ600	
Height		13.3 in.	338 mm	13.3 in.	338 mm
Width		10.9 in.	278 mm	13.4 in.	341 mm
Depth		18.7 in.	475 mm	18.7 in.	475 mm
Weight (without options)		32.4 lbs.	15 kg	34.7 lbs.	16 kg
Electrical		90-265 VAC, 48-62 Hz, 5 Amps (fused)		90-265 VAC, 48-62 Hz, 5 Amps (fused)	
Temperature	Operating	40° to 104°F	5° to 40°C	40° to 104°F	5° to 40° C
	Storage	-40° to 140°F	-40° to 60°C	-40° to 140°F	-40° to 60°C
Relative Humidity	Operating	20% to 85%, non-condensing		20% to 85%, non-condensing	
	Storage	5% to 85%, non-condensing		5% to 85%, non-condensing	
Communication Interfaces		<ul style="list-style-type: none"> • USB 2.0 • bi-directional parallel • serial data interface <ul style="list-style-type: none"> • RS-232C, with DB9F connector • Configurable baud rate (300 - 115,200 kB), parity, and data bits. Stop bits can be set at 1 or 2 • Software (XON/XOFF), hardware (DTR/DSR, or RTS/CTS) communication handshake protocols • RS422/485 with optional adapter • ZebraNet® Wireless Plus Print Server - 802.11b/g - compliant wireless print server • ZebraNet® 10/100 Print Server - Ethernet network print server (10BASE-T, 100BASE-TX) 			
Memory		16 MB DRAM memory 8 MB flash memory (2 MB user available)			
Label formats accepted by firmware		<ul style="list-style-type: none"> • ZPL II • XML-Enabled ZPL • EPL II • APL-I • APL-D 			

Printing Specifications

Printing Specifications		ZM400/RZ400		ZM600/RZ600	
Print resolution	203 dots/in.	8 dots/mm	203 dots/in.	8 dots/mm	
	300 dots/in.	12 dots/mm	300 dots/in.	12 dots/mm	
	600 dots/in.	24 dots/mm	N/A	N/A	
Dot size (width x length)	203 dots/in.	0.0049 in. x 0.0049 in.	0.125 mm x 0.125 mm	0.0049 in. x 0.0049 in.	0.125 mm x 0.125 mm
	300 dots/in.	0.0033 in. x 0.0039 in.	0.084 mm x 0.099 mm	0.0033 in. x 0.0039 in.	0.084 mm x 0.099 mm
	600 dots/in.	0.0016 in. x 0.0016 in.	0.042 mm x 0.042 mm	N/A	N/A
First dot location measured from inside media backing edge	0.10 in. ± 0.04 in.	(2.5 mm ± 1 mm)	0.10 in. ± 0.04 in.	(2.5 mm ± 1 mm)	
Maximum print width	203 dots/in.	4.09 in.	104 mm	6.6 in.	168 mm
Minimum print length	1 dot row		1 dot row		
Maximum continuous print length	203 dots/in.	157 in.	3988 mm	102 in.	2590 mm
	300 dots/in.	73 in.	1854 mm	45 in.	1143 mm
	600 dots/in.	20 in.	508 mm	N/A	N/A
Bar code modulus (X) dimension	Picket fence (non-rotated) orientation				
	203 dots/in.	4.9 mil to 49 mil		4.9 mil to 49 mil	
	300 dots/in.	3.3 mil to 33 mil		3.3 mil to 33 mil	
	600 dots/in.	1.6 mil to 16 mil		N/A	
	Ladder (rotated) orientation				
	203 dots/in.	4.9 mil to 49 mil		4.9 mil to 49 mil	
	300 dots/in.	3.9 mil to 39 mil		3.3 mil to 33 mil	
600 dots/in.	1.6 mil to 16 mil		N/A		

Printing Specifications	ZM400/RZ400	ZM600/RZ600	
Programmable constant print speeds	203 dots/in.	<ul style="list-style-type: none"> • 2.4 in. (61 mm) per second • 3 in. through 10 in. per second in 1-in. increments (76 mm through 254 mm per second in 25-mm increments) 	<ul style="list-style-type: none"> • 2.4 in. (61 mm) per second • 3 in. through 10 in. per second in 1-in. increments (76 mm through 254 mm per second in 25-mm increments)
	300 dots/in.	<ul style="list-style-type: none"> • 2.4 in. (61 mm) per second • 3 in. through 8 in. per second in 1-in. increments (76 mm through 203 mm per second in 25-mm increments) 	<ul style="list-style-type: none"> • 2.4 in. (61 mm) per second • 3 in. through 8 in. per second in 1-in. increments (76 mm through 203 mm per second in 25-mm increments)
	600 dots/in.	<ul style="list-style-type: none"> • 1.5 in (38 mm) • 2 in. through 4 in. per second in 1-in. increments (51 mm through 102 mm per second in 25-mm increments) 	N/A

Thin film printhead with E³® Element Energy Control

Media Specifications

Media Specifications		ZM400/RZ400	ZM600/RZ600			
Label length	Minimum	Non-RFID				
		Tear-off	0.5 in.	13 mm	0.5 in.	13 mm
		Peel-off	0.5 in.	13 mm	0.5 in.	13 mm
		Rewind	0.5 in.	13 mm	0.5 in.	13 mm
		Cutter	1 in.	25.4 mm	1.0 in.	25.4 mm
	RFID	Varies for each transponder type				
Maximum	200 or 300 DPI	39 in.	991 mm	39 in.	991 mm	
	600 DPI	20 in.	508 mm	N/A	N/A	
Label width	Minimum	Non-RFID				
		1 in.	25.4 mm	2 in.	51 mm	
	RFID	Varies for each transponder type				
	Maximum	Tear/Cutter	4.5 in.	114 mm	7.0 in.	178 mm
Peel/Rewind		4.25 in.	108 mm	6.75 in.	171 mm	
Total thickness (includes liner, if any)	Minimum	0.0023 in.	0.058 mm	0.0023 in.	0.058 mm	
	Maximum	0.010 in.	0.25 mm	0.010 in.	0.25 mm	
Core size		3 in.	76 mm	3 in.	76 mm	
Maximum roll diameter		8 in.	203 mm	8 in.	203 mm	
Maximum fanfold pack size (length x width x height)		8.0 in. x 4.5 in. x 6.2 in.	203 mm x 114 mm x 157 mm	8.0 in. x 7.0 in. x 6.2 in.	203 mm x 178 mm x 157 mm	
Inter-label gap	Minimum	0.079 in.	2 mm	0.079 in.	2 mm	
	Preferred	0.118 in.	3 mm	0.118 in.	3 mm	
	Maximum	0.157 in.	4 mm	0.157 in.	4 mm	
Ticket/tag notch size (width x length)		0.25 in. x 0.12 in.	6 mm x 3 mm	0.25 in. x 0.12 in.	6 mm x 3 mm	
Hole diameter		0.125 in.	3 mm	0.125 in.	3 mm	
Notch or hole position (Centered from inner media edge)	Minimum	0.15 in.	3.8 mm	0.15 in.	3.8 mm	
	Maximum	2.25 in.	57 mm	3.5 in.	90 mm	
Black mark dimensions	Vertical length		0.098 in. to 0.453 in.	2.5 to 11.5 mm	0.098 in. to 0.453 in.	2.5 to 11.5 mm
	Horizontal width		≥ 0.37 in.	≥ 9.5 mm	≥ 0.37 in.	≥ 9.5 mm
	Location		Within 0.40 in. (1 mm) of inside media edge			
Density, in Optical Density Units (ODU)		> 1.0 ODU				
Maximum media density		0.5 ODU				

Ribbon Specifications

Ribbon can be wound with the coated side on the inside or outside. The ribbon used must match the Thermal Transfer option installed. The standard Thermal Transfer option (black ribbon spindle) uses ribbon coated on the outside, and the alternate Thermal Transfer option (gray ribbon spindle) uses ribbon coated on the inside. For more information, see [Ribbon Overview on page 35](#).

Ribbon Specifications		ZM400/RZ400	ZM600/RZ600		
Ribbon width (Zebra recommends using ribbon at least as wide as the media to protect the printhead from wear.)	Minimum	>2 in.*	51 mm*	>2 in.	51 mm
	Maximum	4.3 in.	110 mm	6.85 in.	174 mm
Standard lengths	2:1 media to ribbon roll ratio	984 ft.	300 m	984 ft.	300 m
	3:1 media to ribbon roll ratio	1476 ft.	450 m	1476 ft.	450 m
Ribbon core inside diameter		1 in.	25.4 mm	1 in.	25.4 mm
Maximum ribbon roll size		3.2 in.	81.3 mm	3.2 in.	81.3 mm

* The narrowest width tested and approved for this printer is 2 in. (51 mm). You may be able to use narrower ribbon, as long as the ribbon is wider than the media being used. To use a ribbon narrower than 2 in. (51 mm), test the ribbon's performance with your media to assure that you get the desired results.

Printer Options

Option	ZM400/RZ400	ZM600/RZ600
Cutter	X	X
Peel-off	X	X
Liner take-up	X	Not available
Factory-installed 64 MB (58 MB user available) Flash memory	X	X
300 dpi printhead	X	X
600 dpi printhead	X	Not available
Rewind	X	X
External print server (10/100 or 10base-T)	X	X
Internal print server (10base-T)	X	X
Wireless print server	X	X



Notes • _____

Index



A

- adhesive test for ribbon coating, 35
- adjustments
 - label left side, 91
 - left position, 92
 - media alignment for rewind, 108
 - print darkness, 70
 - printhead pressure, 61
 - tear-off position, 72
- APL-D
 - set Module A storage device, 73
 - set Module B storage device, 74
 - setting compatibility mode, 73
 - setting control codes, 73
- APL-I
 - adjust label left position, 91
 - print stored format, 82
 - print stored page, 81
 - set printer resolution, 74
 - status response, 87
- auto calibration, 60

B

- backfeed setting, 91
- bar codes
 - list available codes, 79
- battery disposal, 98
- baud setting, 85
- before you begin setup, 24
- bitmap scaling factor, 93
- black mark media
 - described, 34

C

- calibration
 - media and ribbon sensor, 84
 - setting for head close, 90
 - setting for media power up, 90
 - troubleshooting problems, 118
- Canadian DOC compliance, 4
- CANCEL button
 - CANCEL self test, 124
 - description, 19
- checklist
 - before you begin, 24
 - troubleshooting, 110
- cleaning
 - cutter module, 104
 - exterior of printer, 99
 - media compartment and sensors, 103
 - printhead and platen roller, 100
 - recommended cleaning schedule, 99
- communication interfaces, 27
- communications diagnostics test
 - overview, 130
 - selecting, 88
- communications problems, 119
- components of printer, 17
- configuration
 - changing parameters, 69
 - enter Setup mode, 64
 - exit Setup mode, 65
 - software or printer driver, 69
- configuration label
 - printing using CANCEL self test, 124
 - printing using List Setup command, 80

- connect printer to computer or network, 28
- connect to power source, 31
- contacts, 11
- continuous media
 - described, 34
 - setting media type, 74
- control panel
 - buttons described, 19
 - enter Setup mode, 64
 - exit Setup mode, 65
 - LCD error messages, 111
 - lights described, 20
 - location, 16
 - overview and illustration, 18
 - parameters, 69
- control prefix setting, 88
- counters, 79
- customer service, 11
- cutter
 - cleaning, 104
 - Cutter Jam** message, 114
 - Cutter mode media path, 40
 - loading media for Cutter mode, 41
 - print mode use described, 38
 - selecting Cutter mode, 73

D

- darkness setting, 70
- data bits setting, 86
- data cables, 28
- data source
 - connections, 27
 - site selection, 26
- date setting, 94
- default password, 66
- defragmenting message, 114
- Delayed Cut mode
 - loading media, 41
 - media path, 40
 - print mode use described, 38
 - selecting, 73
- delimiter character setting, 89
- diagnostics, 123
- direct thermal mode
 - media scratch test, 35
 - setting, 75

- disable password protection, 66
- display language
 - changing from unreadable language, 121
 - selection, 95
- disposal of printer parts, 98
- download firmware, 21
- dpi format conversion, 93

E

- electronics cover, 16
- Eltron Programming Language (EPL), 21
- emulations, 21
- enter Setup mode, 64
- error messages, 111
- Ethernet
 - characteristics of internal wired connection, 27
 - characteristics of wireless connection, 27
 - internal wired connection and configuration, 30
 - wired and wireless connector locations, 16
 - wireless connection and configuration, 30
- exit Setup mode, 65
- external view of printer, 16

F

- factory defaults
 - reload parameters, 65
 - restore network settings, 65
- fanfold media
 - described, 34
 - loading, 42
- FCC compliance, 4
- FEED button
 - description, 19
 - FEED and PAUSE self test, 129
 - FEED self test, 126
- firmware, 21
- Flash memory, 83
- font list, 79
- format convert setting, 93
- format list, 80
- format memory card, 82
- format prefix setting, 88

G

- general specifications, 134

H

- HEAD COLD** message
 - cycling with other messages, 112
 - displayed alone, 113
 - displaying alone, 113
- HEAD ELEMENT BAD** message, 112
- HEAD TOO HOT** message, 113
- host handshake setting, 86
- humidity requirements, 26

L

- label length maximum setting, 76
- label top
 - printer cannot detect, 122
 - setting, 91
- labels did not print, 119
- language
 - changing from unreadable language, 121
 - selection, 95
- LCD messages
 - error messages, 111
 - language selection, 95
 - Setup mode, 69
- left side adjustment, 91
- liability, 2
- liner removal for Rewind mode, 106
- Liner Take-Up mode
 - description, 38
 - loading media, 41
 - media path, 39
- Linerless Peel or Linerless Rewind
 - as print mode options, 38
 - selecting, 73
- list settings
 - all settings, 81
 - bar codes, 79
 - fonts, 79
 - formats, 80
 - images, 79
 - network, 81
 - setup, 80

- load factory defaults, 65
- loading media, 41
- loading ribbon, 55
- lubrication, 98

M

- manual calibration, 60
- mark LED setting, 93
- Mark Med S. setting, 93
- maximum label length setting, 76
- media
 - black mark, 34
 - continuous roll media, 34
 - fanfold, 34
 - loading, 41
 - media LED setting, 93
 - non-continuous roll media, 34
 - ordering, 11
 - perforated, 34
 - RFID "smart" labels, 33
 - setting media type, 74
 - specifications, 137
 - tag stock, 33
 - types of media, 33
 - web, 34
- media and ribbon sensor calibration procedure, 84
- media compartment
 - cleaning, 103
 - components, 17
- media door, 16
- media power up setting, 90
- Media S. setting, 93
- media scratch test, 35
- media sensor
 - calibration, 84
 - print sensor profile, 83

N

- network configuration label
 - printing, 68
 - printing using List Network command, 81
- network ID setting, 87
- non-continuous media
 - described, 34
 - setting media type, 74

O

- odometer, 79
- operating conditions, 26
- options, 139
- ordering replacement parts, 98
- ordering ribbon and media, 11
- OUT OF MEMORY** message, 114

P

- PAPER OUT** message, 112
- parallel port
 - characteristics of parallel connection, 27
 - connection and configuration, 29
 - connector location, 16
 - setting parallel communications, 85
- parity setting, 86
- passwords
 - default, 66
 - disable, 66
 - entering, 66
 - setting password level, 94
- PAUSE button
 - description, 19
 - FEED and PAUSE self test, 129
 - PAUSE self test, 125
- Peel-Off mode
 - loading media, 41
 - media path, 39
 - print mode use described, 38
 - selecting, 73
- perforated media
 - described, 34
- power
 - connect to power source, 31
 - power cord specifications, 32
 - power switch and connector locations, 16
 - site selection, 26
- Power-On Self Test (POST), 123
- print configuration label
 - CANCEL self test, 124
 - List Setup command, 80
- print darkness setting, 70
- print modes
 - described, 38
 - load media for different print modes
 - and options, 41
 - media paths, 39
 - selecting, 73
- print network configuration label, 81
 - instructions and sample label, 68
- print quality
 - troubleshooting, 115
- print server
 - characteristics of internal wired connection, 27
 - characteristics of wireless connection, 27
- print width setting, 75
- printer components, 17
- printer diagnostics, 123
- printer language modes, 21
- printer options, 139
 - described, 38
 - load media for different print modes and options, 41
 - media paths, 39
- printer resolution for APL-I, 74
- printer settings
 - backfeed, 91
 - baud, 85
 - control prefix, 88
 - data bits, 86
 - date, 94
 - delimiter character, 89
 - format convert, 93
 - format prefix, 88
 - host handshake, 86
 - idle display, 94
 - label top, 91
 - language, 95
 - left position, 92
 - maximum label length, 76
 - media type, 74
 - network configuration label as baseline, 68
 - network ID, 87
 - parallel communications, 85
 - parity, 86
 - print darkness, 70
 - print method, 75
 - print width, 75
 - protocol, 87
 - saving, 65
 - serial communications, 85
 - setting through control panel, 64
 - time, 94
 - ZPL mode, 89
- printhead
 - cleaning, 100
 - faulty thermistor, 112
 - head close setting, 90
 - invalid replacement head error, 111
 - pressure adjustment, 61
 - printing specifications, 135
 - protocol setting, 87

R

- recycling printer parts, 98
- registration problems, 118
- relative humidity requirements, 26
- remove used ribbon, 59
- replacement parts, 98
- report shipping damage, 25
- reprint mode for reprinting last label, 92
- restore
 - factory default settings, 65
 - network settings, 65
- Rewind mode
 - adjust media alignment, 108
 - liner removal, 106
 - loading media, 41
 - media path, 40
 - print mode use described, 38
 - selecting, 73
- RFID
 - "smart" labels, 33
- ribbon
 - adhesive test, 35
 - determining coated side, 35
 - loading, 55
 - ordering, 11
 - removing, 59
 - ribbon LED setting, 93
 - scratch test, 36
 - specifications, 138
 - when to use, 35
- RIBBON IN** message, 112
- RIBBON OUT** message, 111
- Ribbon S. setting, 93
- ribbon sensor
 - calibration procedure, 84
 - print sensor profile, 83
- roll media
 - described, 33
 - loading, 42
- routine cleaning schedule, 99
- RTC (real-time clock) setting
 - date, 94
 - idle display, 94
 - time, 94

S

- sales, 11
- scratch test
 - media type, 35
 - ribbon coated side, 36
- self tests, 123
 - CANCEL, 124
 - communications diagnostics, 130
 - FEED, 126
 - FEED and PAUSE, 129
 - PAUSE, 125
 - Power-On Self Test (POST), 123
- sensor profile calibration
 - selecting through control panel, 83
- sensors
 - cleaning, 103
 - interpreting sensor profile, 131
 - print sensor profile, 83
- serial port
 - characteristics of serial connection, 27
 - connection and configuration, 28
 - connector location, 16
 - setting serial communications, 85
- setup
 - checklist, 24
 - unpack the printer, 25
- Setup mode
 - enter Setup mode, 64
 - exit Setup mode, 65
 - LCD messages, 69
 - passwords, 66
- shipping
 - report damage, 25
 - reshipping the printer, 25
- "smart" labels, 33
- spacing requirements, 26
- specifications
 - general, 134
 - media, 137
 - power cord, 32
 - printing, 135
 - ribbon, 138
- storing the printer, 25
- surface for the printer, 26

T

- tag stock described, 33
- Tear-Off mode
 - loading media, 41
 - media path, 39
 - print mode use described, 38
 - selecting, 73
 - tear-off position adjustment, 72
- technical support, 11
- temperature requirements, 26
- thermal transfer mode
 - media scratch test, 35
 - setting, 75
- THERMISTOR FAULT** message
 - cycling with other messages, 112
 - displayed alone, 112
- time setting, 94
- top of label
 - printer cannot detect, 122
 - setting, 91
- troubleshooting
 - checklist, 110
 - communications problems, 119
 - diagnostic tests, 123
 - LCD error messages, 111
 - print quality problems, 115
- types of media
 - black mark media, 34
 - continuous roll media, 34
 - fanfold media, 34
 - non-continuous roll media, 34
 - perforated media, 34
 - RFID "smart" labels, 33
 - tag stock, 33
 - web media, 34

U

- unpack the printer, 25
- USB port
 - characteristics of USB connection, 27
 - connection and configuration, 29
 - connector location, 16

W

- web media described, 34
- Web S. setting, 93
- wired print server
 - characteristics, 27
 - connector location, 16
 - internal wired connection and configuration, 30
 - view active print server, 68
- wireless cards, 28
- wireless print server
 - characteristics, 27
 - connection and configuration, 30
 - connector location, 16
 - view active print server, 68

Z

- Zebra Programming Language (ZPL)
 - downloading firmware, 21
 - ZPL mode setting, 89



Zebra Technologies International, LLC
333 Corporate Woods Parkway
Vernon Hills, Illinois 60061.3109 U.S.A
T: +1 847 793 2600
Toll-free +1 800 423 0422
F: +1 847 913 8766

Zebra Technologies Europe Limited
Zebra House
The Valley Centre, Gordon Road
High Wycombe
Buckinghamshire, HP13 6EQ, UK
T: +44 (0)1494 472872
F: +44 (0) 1494 450103

Zebra Technologies Asia Pacific, LLC
120 Robinson Road
#06-01 Parakou Building
Singapore 068913
T: +65 6858 0722
F: +65 6885 0838

<http://www.zebra.com>

Part Number: 79695L-002 Rev. A
© 2008 ZIH Corp.