

Figure 6-14 *Insert WT6000 into Cradle*

2. Ensure that the WT6000 is properly seated in the charging slot.

Battery Charging

The WT6000 Charging LED indicates the charging status of the battery in the WT6000. See [Table 6-2 on page 6-5](#). The 3,350 mAh battery fully charges in less than four hours at room temperature.

Charge batteries in temperatures from 0 °C to 40 °C (32 °F to 104 °F). The battery charger always performs battery charging in a safe and intelligent manner. At higher temperatures (e.g. approximately +37 °C (+98 °F)) the battery charger may for small periods of time alternately enable and disable battery charging to keep the battery at acceptable temperatures. The battery charger indicates when charging is disabled due to abnormal temperatures via its LED.

5-Slot WT6000 Ethernet Cradle

✓ **NOTE** Ensure that you follow the guidelines for battery safety described in [Battery Safety Guidelines on page 7-1](#).

The 5-Slot WT6000 Ethernet Cradle:

- Provides 5.4 VDC (nominal) power for operating the WT6000.
- Connects up to five WT6000 devices to an Ethernet network.
- Simultaneously charges up to five WT6000 devices.
- Simultaneously charges up to five spare batteries.

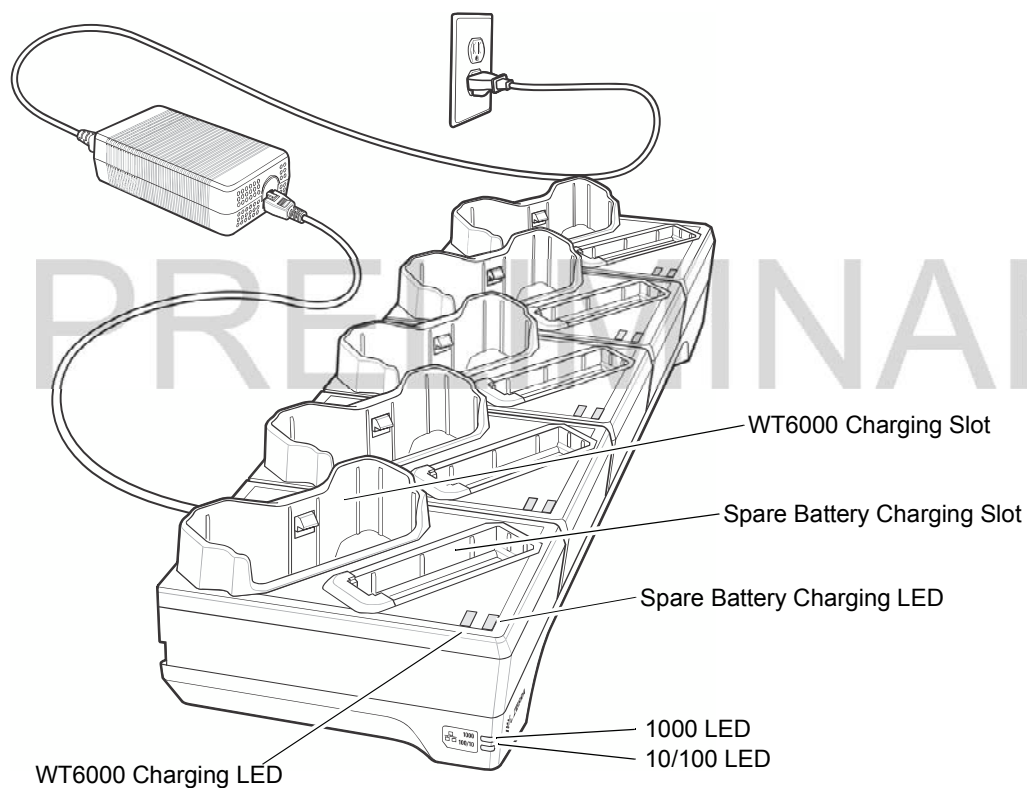

Figure 6-15 5-Slot WT6000 Ethernet Cradle

Charging the WT6000

To charge the WT6000:

1. Insert the WT6000 in the WT6000 charging slot.

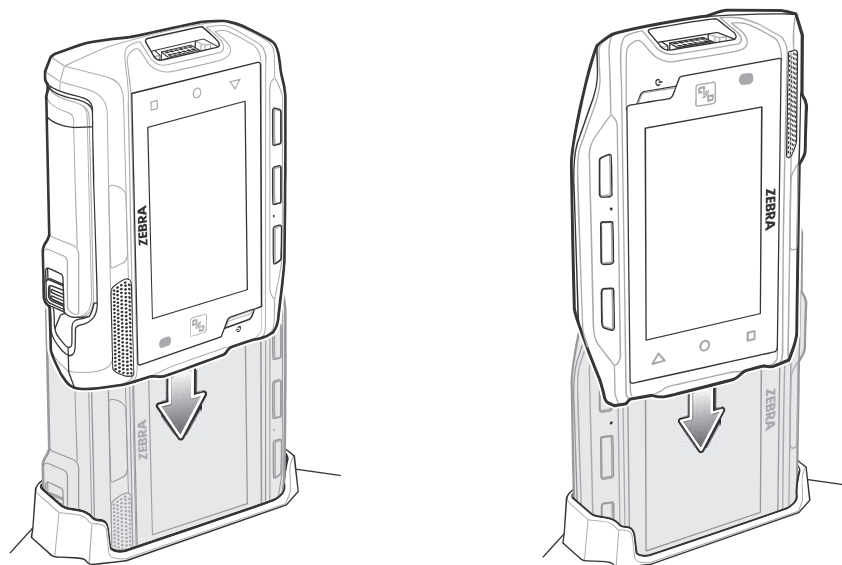

Figure 6-16 Insert WT6000 into Cradle

2. Ensure that the WT6000 is properly seated in the charging slot.

Charging the Spare Battery

1. Insert a spare battery into the spare battery slot.

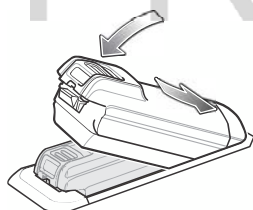

Figure 6-17 Insert Battery into Cradle

2. Ensure the battery is seated properly. The Spare Battery Charging LED blinks indicating charging.



Battery Charging

The WT6000 Charging LED indicates the charging status of the battery in the WT6000 and the Spare Battery Charging LED indicates the charging status of the spare battery. See [Table 6-2 on page 6-5](#). The 3,350 mAh battery fully charges in less than four hours at room temperature.

Charge batteries in temperatures from 0 °C to 40 °C (32 °F to 104 °F). The battery charger always performs battery charging in a safe and intelligent manner. At higher temperatures (e.g. approximately +37 °C (+98 °F)) the battery charger may for small periods of time alternately enable and disable battery charging to keep the battery at acceptable temperatures. The battery charger indicates when charging is disabled due to abnormal temperatures via its LED.

Establishing Ethernet Communication

- ✓ **NOTE** Refer to the WT6000 Integrator Guide for information on configuring the Ethernet settings.

1. Touch .
2. Touch **Ethernet**.
3. Slide the Ethernet switch to the **ON** position.
4. Insert the device into a slot.
5. The  icon appears in the Status bar.
6. Touch **Eth0** to view Ethernet connection details.

Ethernet LED Indicators

There are two green LEDs on the side of the cradle. These green LEDs light and blink to indicate the data transfer rate.

Table 6-3 *LED Data Rate Indicators*

Data Rate	1000 LED	100/10 LED
1 Gbps	On/Blink	Off
100 Mbps	Off	On/Blink
10 Mbps	Off	On/Blink

4-Slot Battery Charger

- ✓ **NOTE** Ensure that you follow the guidelines for battery safety described in [Battery Safety Guidelines on page 7-1](#).

The 4-Slot Battery Charger charges up to four spare batteries.

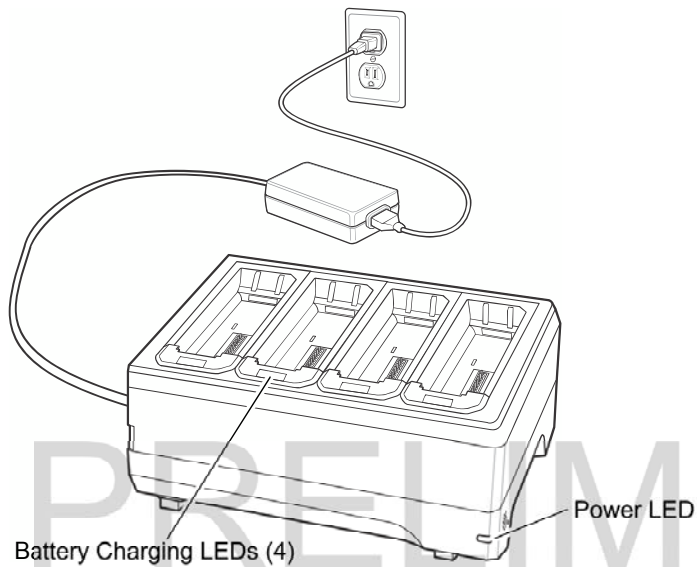

Figure 6-18 4-Slot Battery Charger

Battery Installation

To install the battery:

1. Insert the battery into a battery slot.
2. Gently press down on the battery until it snaps into place.

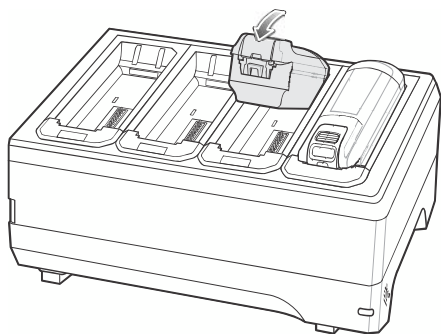

Figure 6-19 Insert Battery into Slot

Battery Removal

To remove the battery, press the two release latches on each side of the battery and lift the battery out of the battery slot.

Battery Charging

Spare Battery Charging

Each Battery Charging LED indicates the status of the battery charging in each slot. See [Table 6-2 on page 6-5](#). The 3,350 mAh battery fully charges in less than four hours at room temperature.

Charge batteries in temperatures from 0 °C to 40 °C (32 °F to 104 °F). The battery charger always performs battery charging in a safe and intelligent manner. At higher temperatures (e.g. approximately +37 °C (+98 °F)) the battery charger may for small periods of time alternately enable and disable battery charging to keep the battery at acceptable temperatures. The battery charger indicates when charging is disabled due to abnormal temperatures via its LED.

PRELIMINARY

20-Slot Battery Charger

✓ **NOTE** Ensure that you follow the guidelines for battery safety described in [Battery Safety Guidelines on page 7-1](#).

The 20-Slot Battery Charger charges up to 20 spare batteries.

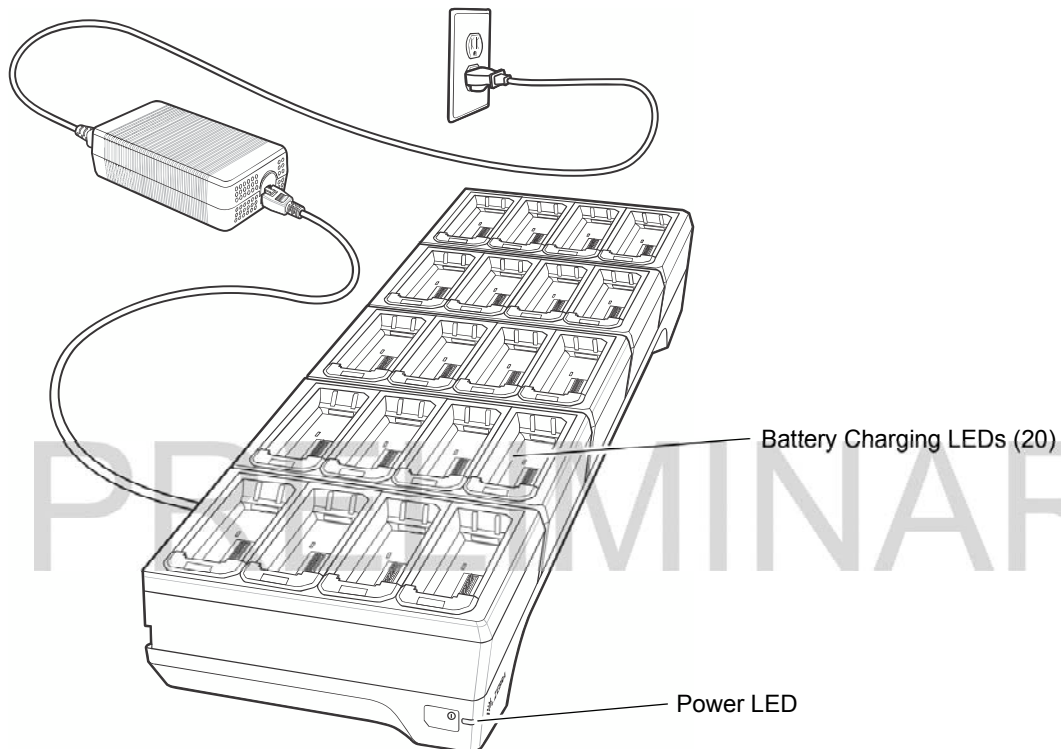

Figure 6-20 20-Slot Battery Charger

Battery Installation

To install the battery:

1. Insert the battery into a battery slot.
2. Gently press down on the battery until it snaps into place.

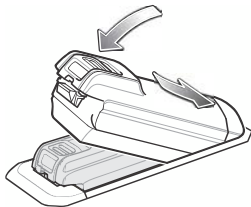

Figure 6-21 Insert Battery into Slot

Battery Removal

To remove the battery, press the two release latches on each side of the battery and lift the battery out of the battery slot.

Battery Charging

Spare Battery Charging

Each Battery Charging LED indicates the status of the battery charging in each slot. See [Table 6-2 on page 6-5](#). The 3,350 mAh battery fully charges in less than four hours at room temperature.

Charge batteries in temperatures from 0°C to 40°C (32°F to 104°F). The battery charger always performs battery charging in a safe and intelligent manner. At higher temperatures (e.g. approximately +37°C (+98°F)) the battery charger may for small periods of time alternately enable and disable battery charging to keep the battery at acceptable temperatures. The battery charger indicates when charging is disabled due to abnormal temperatures via its LED.

PRELIMINARY

USB and Charging Cable

✓ **NOTE** Ensure that you follow the guidelines for battery safety described in [Battery Safety Guidelines on page 7-1](#).

The USB and Charging cable connects to either interface connector on the WT6000. When attached to the WT6000, allows the WT6000 to transfer data to a host computer and provide power for charging the WT6000.

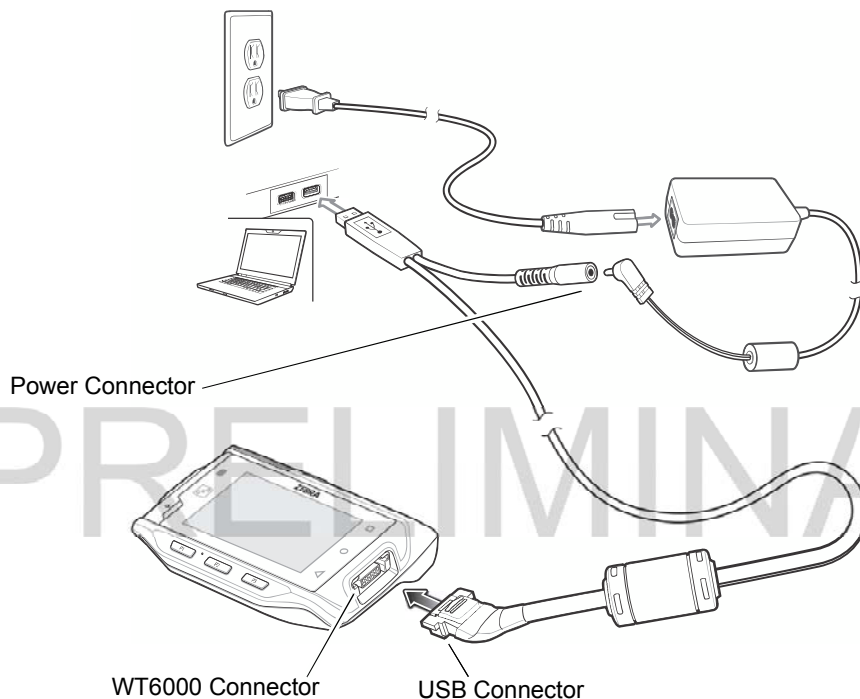

Figure 6-22 *USB and Charging Cable*

Attaching the USB and Charging Cable

1. Connect the connector to the WT6000 interface connector.

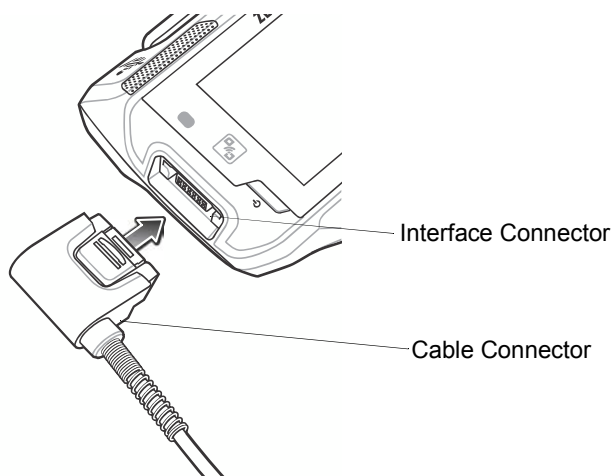

Figure 6-23 *Connecting Scanner to WT6000*

2. Attach the USB connection to the host computer.

Removing the USB and Charging Cable

To remove the USB and Charging cable:

1. Press the release level toward the cable.
2. Rotate the adapter toward the front of the device and remove.

Battery Charging

To charge the WT6000, attached the power cable to the Power Connection on the USB and Charging Cable.

Main Battery Charging

The WT6000 Charging/Scan LED indicates the status of the battery charging in the device. See [Table 1-3 on page 1-4](#). The 3,350 mAh battery fully charges in less than four hours at room temperature.

Charging Temperature

Charge batteries in temperatures from 0°C to 40°C (32°F to 104°F). The battery charger always performs battery charging in a safe and intelligent manner. At higher temperatures (e.g. approximately +37°C (+98°F)) the battery charger may for small periods of time alternately enable and disable battery charging to keep the battery at acceptable temperatures. The battery charger indicates when charging is disabled due to abnormal temperatures via its LED.

Quick Disconnect Audio Cables

The Quick Disconnect Audio Adapter snaps into either interface connector. When attached to the WT6000, the Quick Disconnect Audio Adapter allows a user to connect a wired headset to the WT6000.

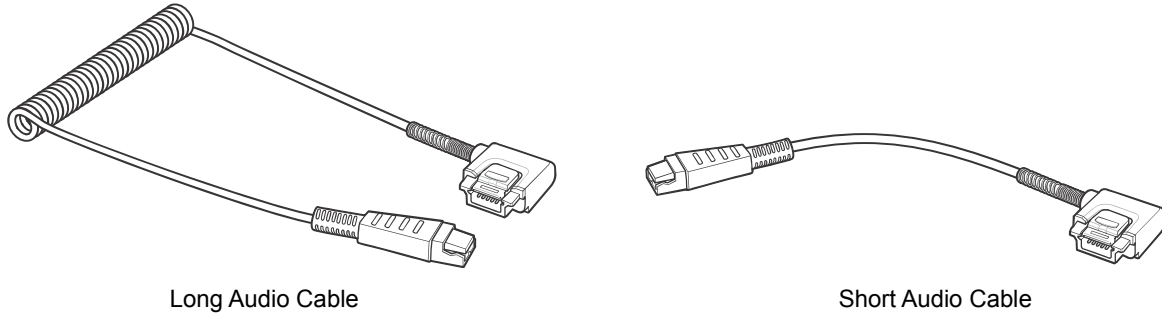

Figure 6-24 *Audio Cables*

Attaching the Audio Adapter

1. Align the tabs on the Audio Adapter with the slots on the device.
2. Rotate the Adapter toward the back of the device until the Adapter snaps onto the device.

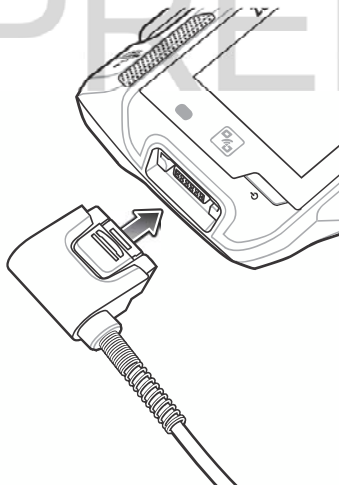
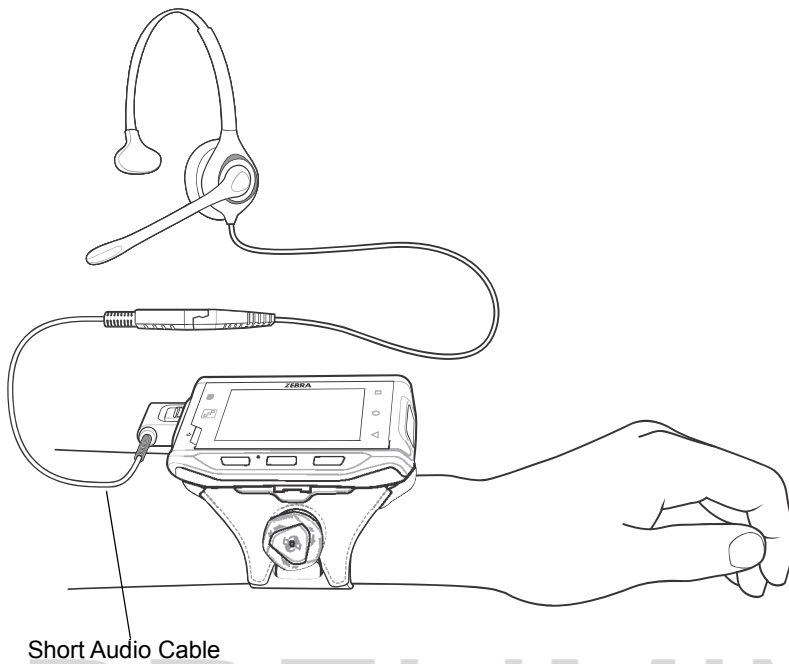

Figure 6-25 *Attach Cable to WT6000*

Connecting the Audio Cable to a Headset



Short Audio Cable
Figure 6-26 *Short Quick Disconnect Audio Cable Connection to Headset*

Removing the Audio Adapter

To remove the Audio Adapter:

1. Press the release level toward the cable.
2. Rotate the adapter toward the front of the device and remove.

Vibrator Cable

Use the Vibrator cable to provide a touch notification to a user to in noisy environments.

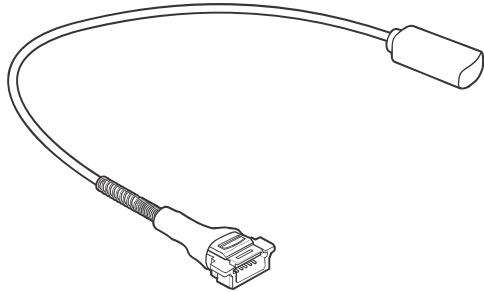

Figure 6-27 *Vibrator Cable*

Connect the cable to the Interface connector on the WT6000.

Slide the vibrator end between the Wrist Mount strap and arm.

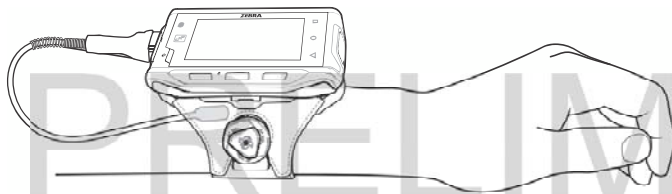

Figure 6-28 *Connecting Vibrator Cable to WT6000*

When an application generates a notification, the vibrator vibrates notifying the user.

RS4000 Scanner

To connect the RS4000 scanner to the WT6000:

- ✓ **NOTE** There are two scanner configurations available. The short cable configuration connects the scanner to the WT6000 mounted on the arm. The extended cable configuration connects the scanner to the WT6000 mounted on the hip.

1. Connect the scanner interface cable to the WT6000 interface connector. If the WT6000 is mounted on the arm, connect the cable to the interface connector closest to the wrist.

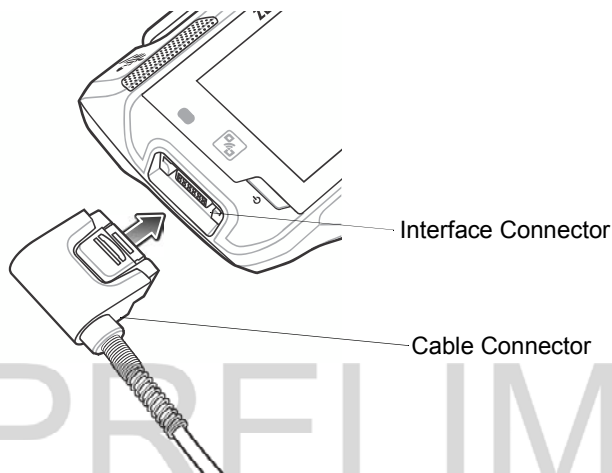

Figure 6-29 Connecting Scanner to WT6000

2. If using the extended cable configuration, route the scanner cable up to the shoulder and down to the hand that the scanner mounts on. Attach two cable clips to clothing and secure cable to cable clip.

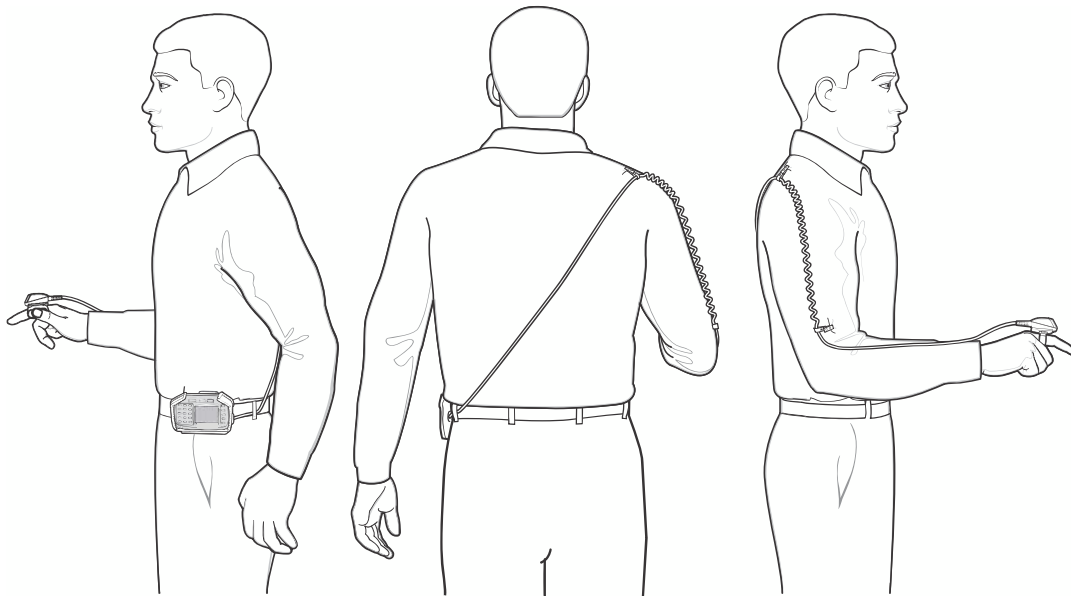

Figure 6-30 Cable Clip Installation

3. Rotate the trigger assembly to the correct position for the hand that the scanner mounts to.

4. Slide the scanner onto the index finger with the scan trigger next to the thumb.

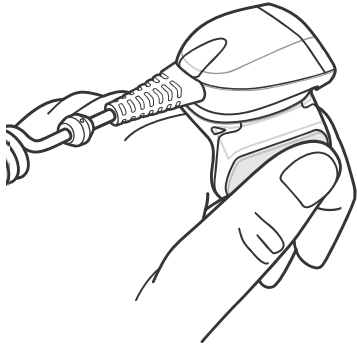

Figure 6-31 *Place the Scanner on Index Finger*

5. Tighten the finger strap.

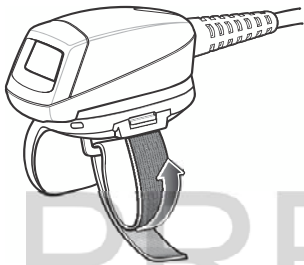

Figure 6-32 *Tightening Straps*

6. If required, cut excess finger strap material.

After connecting the scanner, warm boot the WT6000. See [Resetting the Wearable Terminal on page 2-19](#) for information on performing a warm boot.

CHAPTER 7 MAINTENANCE AND TROUBLESHOOTING

Introduction

This chapter includes instructions on cleaning and storing the WT6000, battery maintenance and provides troubleshooting solutions for potential problems during WT6000 operations.

Maintaining the WT6000

For trouble-free service, observe the following tips when using the WT6000:

- Protect the WT6000 from temperature extremes.
- Do not store or use the WT6000 in any location that is extremely dusty, damp, or wet.
- ~~Use a soft lens cloth to clean the scan exit window of the WT6000.~~ If the surface of the WT6000 screen becomes soiled, clean it with a soft cloth moistened with a diluted window-cleaning solution. Do not use bleach, ~~or ammonia~~ or hydrogen peroxide products.
- Take care not to scratch the screen of the WT6000.
- The display of the WT6000 contains glass. Take care not to drop the WT6000 or subject it to strong impact.

Battery Safety Guidelines

- The area in which the WT6000 units are charged should be clear of debris and combustible materials or chemicals. Particular care should be taken where the device is charged in a non-commercial environment.
- Do not use incompatible batteries and chargers. If you have any questions about the compatibility of a battery or a charger, contact Zebra Support. See [Service Information on page xiv](#) for contact information.
- Do not crush, puncture, or place a high degree of pressure on the battery.
- Follow battery usage, storage, and charging guidelines.
- Improper battery use may result in a fire, explosion, or other hazard.
- To charge the mobile device battery, the battery and charger temperatures must be between +32°F and +104°F (0°C and +40°C)

- Do not disassemble or open, crush, bend or deform, puncture, or shred.
- Severe impact from dropping any battery-operated device on a hard surface could cause the battery to overheat.
- Do not short circuit a battery or allow metallic or conductive objects to contact the battery terminals.
- Do not modify or remanufacture, attempt to insert foreign objects into the battery, immerse or expose to water or other liquids, or expose to fire, explosion, or other hazard.
- Do not leave or store the equipment in or near areas that might get very hot, such as in a parked vehicle or near a radiator or other heat source. Do not place battery into a microwave oven or dryer.
- Battery usage by children should be supervised.
- Please follow local regulations to promptly dispose of used re-chargeable batteries.
- Do not dispose of batteries in fire.
- Seek medical advice immediately if a battery has been swallowed.
- In the event of a battery leak, do not allow the liquid to come in contact with the skin or eyes. If contact has been made, wash the affected area with large amounts of water and seek medical advice.
- If you suspect damage to your equipment or battery, call Customer Support to arrange for inspection. See [Service Information on page xiv](#) for contact information.

Long Term Storage

When storing the WT6000 for a long period of time, it is recommended to remove the battery. When returning the WT6000 to everyday operation, install a fully charged battery.

Cleaning Instructions



CAUTION Always wear eye protection.

Read warning label on compressed air and alcohol product before using.

If you have to use any other solution for medical reasons please contact Zebra for more information.



WARNING! Avoid exposing this product to contact with hot oil or other flammable liquids. If such exposure occurs, unplug the device and clean the product immediately in accordance with these guidelines.

Approved Cleanser Active Ingredients

100% of the active ingredients in any cleaner must consist of one or some combination of the following: isopropyl alcohol, ~~bleach/sodium hypochlorite, hydrogen peroxide~~ or mild dish soap.

Harmful Ingredients

The following chemicals are known to damage the plastics on the device and should not come in contact with the device: ammonia solutions, compounds of amines or ammonia; acetone; ketones; ethers; aromatic and chlorinated

hydrocarbons; aqueous or alcoholic alkaline solutions; ethanolamine; toluene; trichloroethylene; benzene; carbolic acid, ~~and~~ TB-lysoform, [bleach products and hydrogen peroxide](#).

Cleaning Instructions

Do not apply liquid directly to the device. Dampen a soft cloth or use pre-moistened wipes. Do not wrap the device in the cloth or wipe, but gently wipe the unit. Be careful not to let liquid pool around the display window or other places. Allow the unit to air dry before use.

Special Cleaning Notes

Many vinyl gloves contain phthalate additives, which are often not recommended for medical use and are known to be harmful to the housing of the device. The device should not be handled while wearing vinyl gloves containing phthalates, or before hands are washed to remove contaminant residue after gloves are removed. If products containing any of the harmful ingredients listed above are used prior to handling the device, such as hand sanitizer that contain ethanolamine, hands must be completely dry before handling the device to prevent damage to the plastics.

Cleaning Materials Required

- Alcohol wipes
- Lens tissue
- Cotton tipped applicators
- Isopropyl alcohol
- Can of compressed air with a tube.

Cleaning Frequency

The cleaning frequency is up to the customer's discretion due to the varied environments in which the WT6000 units are used. They may be cleaned as frequently as required. However when used in dirty environments it may be advisable to periodically clean the scanner exit window to ensure optimum scanning performance.

Cleaning the WT6000

Housing

Using the alcohol wipes, wipe the housing.

Display

The display can be wiped down with the alcohol wipes, but care should be taken not to allow any pooling of liquid around the edges of the display. Immediately dried the display with a soft, non-abrasive cloth to prevent streaking.

Power Connector

1. Remove the battery from WT6000.
2. Dip the cotton portion of the cotton tipped applicator in isopropyl alcohol.
3. Rub the cotton portion of the cotton tipped applicator back-and-forth across the connector inside the handle of the WT6000. Do not leave any cotton residue on the connector.

4. Repeat at least three times.
5. Use the cotton tipped applicator dipped in alcohol to remove any grease and dirt near the connector area.
6. Use a dry cotton tipped applicator and repeat steps 3 through 5.
7. Spray compressed air on the connector area by pointing the tube/nozzle about ½ inch away from the surface.



CAUTION Do not point nozzle at yourself and others, ensure the nozzle or tube is away from your face.

8. Inspect the area for any grease or dirt, repeat if required.

Cleaning Cradle Connectors

Use this procedure to clean the connectors on a cradle:

1. Remove power from the cradle.
2. Dip the cotton portion of the cotton tipped applicator in isopropyl alcohol.
3. Rub the cotton portion of the cotton tipped applicator along the pins of the connector. Slowly move the applicator back-and-forth from one side of the connector to the other. Do not let any cotton residue on the connector.
4. All sides of the connector should also be rubbed with the cotton tipped applicator.
5. Spray compressed air in the connector area by pointing the tube/nozzle about ½ inch away from the surface.



CAUTION Do not point nozzle at yourself and others, ensure the nozzle or tube is pointed away from your face.

6. Ensure that there is no lint left by the cotton tipped applicator, remove lint if found.
7. If grease and other dirt can be found on other areas of the cradle, use lint free cloth and alcohol to remove.
8. Allow at least 10 to 30 minutes (depending on ambient temperature and humidity) for the alcohol to air dry before applying power to cradle.

If the temperature is low and humidity is high, longer drying time is required. Warm temperature and dry humidity requires less drying time.

Cleaning the Wrist Mount

It may be necessary to wash the wrist mount strap and replaceable comfort pad when they become soiled.

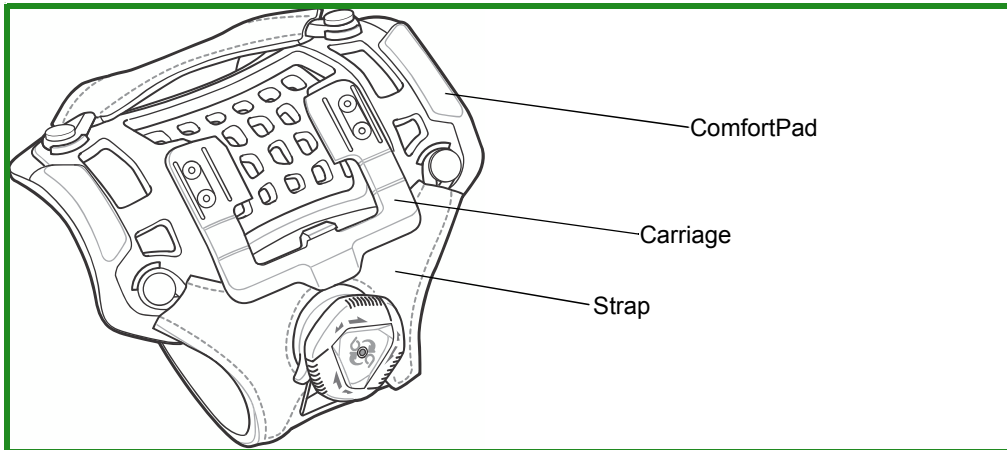

Figure 7-1 *Wrist Mount*

Remove the strap and comfort pad from the wrist mount. Hand wash in cold water with a mild detergent (such as Woolite®). Do not use bleach. Air dry. Do not use a dryer.



Figure 7-2 *Comfort Pad*

PRELIMINARY

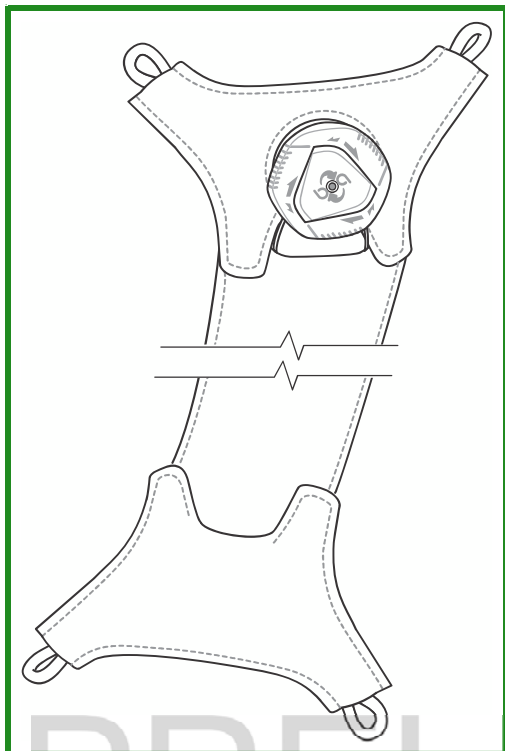

Figure 7-3 *Strap*

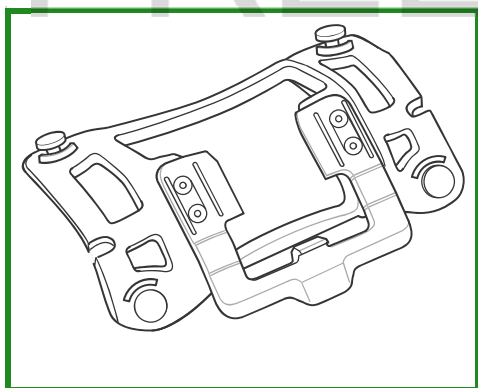

Figure 7-4 *Carrier*

PRELIMINARY

Troubleshooting

WT6000

Table 7-1 Troubleshooting the WT6000

Problem	Cause	Solution
WT6000 does not turn on.	Battery not charged.	Charge or replace the battery in the WT6000.
	Battery not installed properly.	Ensure battery is installed properly. See Installing the Battery on page 1-3 .
	System crash.	Perform a soft reset. If the WT6000 still does not turn on, perform a hard reset. See Resetting the WT6000 on page 2-11 .
Battery did not charge.	Battery failed.	Replace battery. If the WT6000 still does not operate, try a soft reset, then a hard reset. See Resetting the WT6000 on page 2-11 .
	WT6000 removed from cradle before charging completed.	Insert the WT6000 into the cradle and begin charging. The battery fully charges in less than four hours.
	Ambient temperature of the cradle is too warm or too cold.	The ambient temperature must be between 0 °C and 40 °C (32 °F and 104 °F).
During data communication, no data was transmitted, or transmitted data was incomplete.	WT6000 unplugged from host computer during communication.	Reconnect the programming cable to the host computer and re-transmit.
	Communication software was incorrectly installed or configured.	See system administrator.
WT6000 turns itself off.	WT6000 is inactive.	The WT6000 turns off after a period of inactivity. If the WT6000 is running on battery power, this period can be set to 15 seconds, 30 seconds, 1 minute, 2 minutes, 5 minutes, 10 minutes, or 30 minutes. Change the setting if you need a longer delay before the automatic shutoff feature activates.
	Battery is depleted.	Place the WT6000 in the cradle to re-charge the battery.
	The WT6000's battery is low and it powers down to protect memory content.	Place the WT6000 in the cradle to re-charge the battery.

Table 7-1 Troubleshooting the WT6000 (Continued)

Problem	Cause	Solution
A message appears stating that the WT6000 memory is full.	Too many files stored on the WT6000.	Delete unused memos and records. You can save these records on the host computer.
	Too many applications installed on the WT6000.	If you have installed additional applications on the WT6000, remove them to recover memory.
The WT6000 does not accept scan input.	Unreadable bar code.	Ensure the symbol is not defaced.
	Distance between scanner exit window and bar code is incorrect.	Move the WT6000 closer or further from the bar code to the proper scanning range.
	WT6000 is not programmed for the bar code.	Verify that the WT6000 can read the type of bar code being scanned (See Technical Specifications). Ensure that the bar code parameters are set properly for the bar code being scanned.
	WT6000 is not programmed to generate a beep.	Verify that a beep on a good decode is used.
During USB data communications, no data was transmitted, or transmitted data was incomplete.	Incorrect cable connection.	See Chapter 6, Accessories .
	Communications software is not installed or configured properly.	Perform setup as described in Chapter 6, Accessories .

APPENDIX A SPECIFICATIONS

Technical Specifications

The following tables summarize the WT6000's intended operating environment and general technical hardware specifications.

Table A-1 *Technical Specifications*

Item	Description
Physical and Environmental Characteristics	
Dimensions (H x L x W)	121 mm x 89mm x 34 mm 4.8 in. x 3.5 in. x 1.3 in.
Weight	245 g (8.7 oz.)
Display	Color Transflective LCD Display and IPS Technology, 3.2 in. diagonal, WVGA (800 x 480 pixels), 24 bits (16 million pixels), 400+ Nits
Touch Panel	Multi-Touch projected capacitive; fingertip (bare or gloved) input; conductive stylus supported (sold separately)); Corning® Gorilla® Glass
Backlight	Configurable LED backlight control
Battery	PowerPrecision+ rechargeable 3.7 VDC 3,350 mAh Lithium-Ion battery.
Backup Power	SuperCap technology
Notification	Vibration, Audible tone, Multi - colour LEDs
Voice and Audio	Integrated Speaker, Mono wired headsets with a mic and push-to-talk button and Bluetooth wireless headset support.
Performance Characteristics	
CPU	Quad-Core 1.0 GHz processor
Operating System	Android AOSP 5.1 (Lollipop) with Mobility Extensions (Mx), for true enterprise class operating system.

Table A-1 *Technical Specifications (Continued)*

Item	Description
Memory	1 GB RAM, 4 GB Flash (pSLC)
Application Development	Zebra Android EMDK
User Environment	
Operating Temperature	-30°C to 50°C (-22°F to 122°F)
Storage Temperature	-40°C to 70°C (-40°F to 158°F)
Battery Charging Temperature	0°C to +40°C (32°F to 104°F) ambient temperature range.
Humidity	5% - 95% non-condensing
Drop Specification	1.2 m (4 ft.) drop to concrete (36 drops, over temperature range)
Tumble	1,000 tumbles @ 0.5 m (1.6 ft.) (room temperature)
Vibration	Sine 5-2000 Hz, 4g peak, 1 hour per axis Random 20-2000 Hz, 6g RMS or 0.04g ² /Hz, 1 hour per axis
ESD	± 20k VDC air discharge ± 10k VDC contact discharge ± 10k VDC indirect discharge
Wireless LAN Data Communications	
Radio	IEEE 802.11a/b/g/n/ac
Data Rates	5 GHz: 802.11a/n - up to 300 Mbps; 802.11ac - Single-stream and dual-stream solution with data rates up to 433.3 and 866.7 Mbps 2.4 GHz: 802.11b/g/n - up to 72.2 Mbps (one stream) 144.4 Mbps (dual stream)
Operating Channels	Channels 36 - 165 (5180 - 5835 MHz) Channels 1 - 13 (2412 - 2472 MHz) Actual operating channels/frequencies depend on regulatory rules and certification agency
Security and Encryption	WEP, WPA - TKIP, WPA2- TKIP, WPA2-AES EAP-TTLS/PAP, EAP-TTLS/MSCHAPv2, PEAPv0/EAP-MSCHAPv2, PEAPv1/EAP-GTC, TTLS-MSCHAP, EAP-TLS, EAP-FAST (MSCHAPv2 and GTC), LEAP VPN functionality (L2TP, PPTP and IPSec)
Multimedia	Wi-Fi Multimedia™ (WMM)
Certifications	802.11n, 802.11ac, CCXv4, Wi-Fi Direct
Fast Roam	PMKID Caching, Opportunistic Key Caching (OKC), Cisco CCKM, 802.11r.
Wireless PAN Data Communications	
Bluetooth	Bluetooth 4.1 (Bluetooth Smart Technology)

Table A-1 *Technical Specifications (Continued)*

Item	Description
Data Capture	
Laser Scanning	Optional RS4000 laser scanner.
Imager	Optional Rs507 and RS6000 ring scanners.
NFC	Multi-Protocol NFC (optional).

PRELIMINARY

PRELIMINARY

INDEX

Numerics

Numerics

1-D bar codes	3-1
2-D bar codes	3-1

A

accessories	6-1
airplane mode	1-13
android version	xii
aplock administrator	2-9

B

bar codes	
one dimensional	3-1
two dimensional	3-1
battery charging temperature	A-2
battery usage	1-12
browser	2-6, 2-7
build number	xii
bullets	xiii

C

calculator	2-6, 2-7
calendar	2-6, 2-7
clock	2-6, 2-7
configuration	xii
contacts	2-6, 2-7
conventions	
notational	xiii
CPU	A-1

D

data capture	
imager operational modes	
decode mode	3-2
pick list mode	3-2
imaging	3-1
laser scanning	3-1
one dimensional bar codes	3-1
scan angle	3-2
scan range	3-2
scanning	3-1
two dimensional bar codes	3-1
datawedge	2-6, 2-7
diagnostics	5-14
dimensions	A-1
display	xii, A-1
downloads	2-6, 2-7
drop specification	A-2
DWDEmo	2-6, 2-7

E

EAP	4-1
Elemex	5-14

F

file browser	5-3
--------------	-----

H

humidity	A-2
----------	-----

I

imager. See data capture, imaging

imaging 3-2
 information, servicexiv

K

keyboard 2-5

L

laser scanning
 See data capture 3-1
 LEDs
 scan and decode 3-3
 lithium-ion battery 1-1
 low battery notification 1-13

M

maintenance 7-1
 memory A-2
 mobile computer
 starting 1-5
 model number xii
 multiuser administrator 2-9

O

operating system A-2
 operating temperature A-2

P

PEAP-GTC 4-1
 PEAP-MSCHAPv2 4-1
 PTT Express 2-8

R

RS507 scanning3-4, 3-5

S

scanning
 bar codes 3-1
 imaging 3-1
 See data capture 3-1
 screen
 Zebra splash screen 1-5
 screen timeout1-14, 1-15
 secure storage administrator 2-9
 serial number xii
 service informationxiv
 set date 1-13
 set time 1-13

set time zone 1-13
 settings 2-8
 sound recorder 2-9
 starting the mobile computer 1-5
 storage temperature A-2

T

TLS 4-1
 troubleshooting 7-6
 TTLS
 TTLS-MSCHAP 4-1
 TTLS-MSCHAPv2 4-1
 TTLS-PAP 4-1

U

unpacking 1-1

W

weight A-1
 WEP 4-1
 WLAN radio A-2
 WPA 4-1

Z

Zebra tap and pair 2-9
 Zebra utilities 2-9

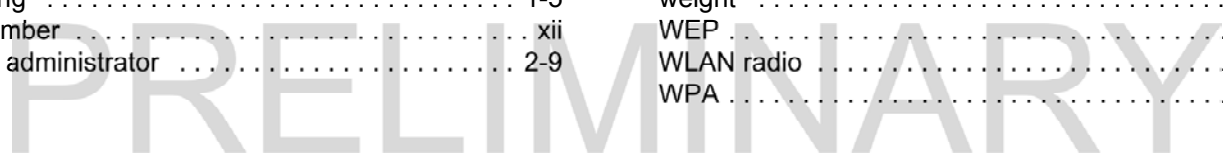

PRELIMINARY

PRELIMINARY



Zebra Technologies Corporation, Inc.
3 Overlook Point
Lincolnshire, IL 60069, U.S.A.
<http://www.zebra.com>

Zebra and the stylized Zebra head are trademarks of ZIH Corp., registered in many jurisdictions worldwide. All other trademarks are the property of their respective owners.

© 2016 Symbol Technologies LLC, a subsidiary of Zebra Technologies Corporation. All Rights Reserved.

MN002410A01 Revision A - December 2015