

# *pilot II*

RevMaster Wireless Cadence Meter

WIRELESS CADENCE METER  
FOR THE LEMOND® REVMASER

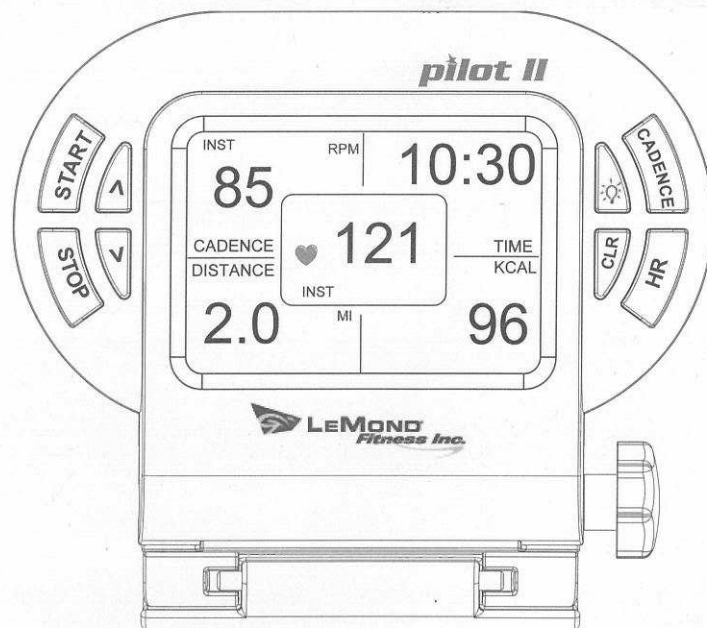

INSTRUCTION MANUAL

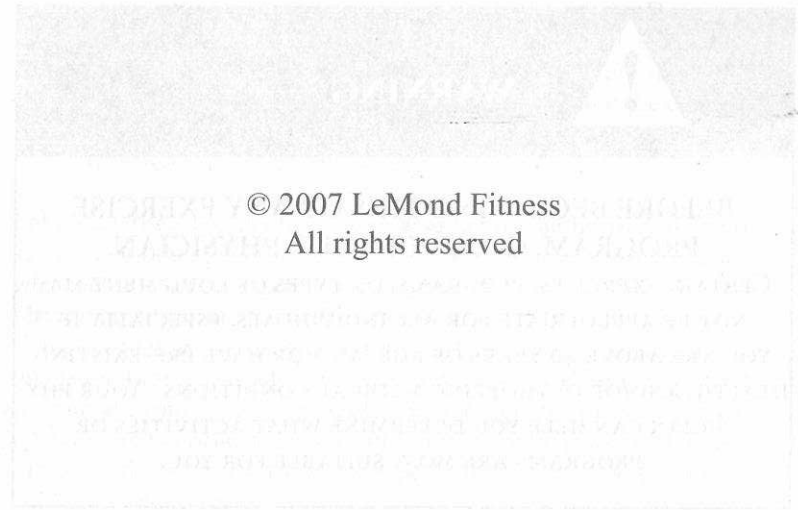

© 2007 LeMond Fitness  
All rights reserved

© 2007 LeMond Fitness. LeMond, RevMaster, and Pilot are registered trademarks of LeMond Fitness in the United States and other countries.

## IMPORTANT SAFETY INSTRUCTIONS



### WARNING

#### BEFORE BEGINNING THIS OR ANY EXERCISE PROGRAM, CONSULT YOUR PHYSICIAN.

CERTAIN EXERCISES, PROGRAMS, OR TYPES OF EQUIPMENT MAY NOT BE APPROPRIATE FOR ALL INDIVIDUALS, ESPECIALLY IF YOU ARE ABOVE 40 YEARS OF AGE, AND/OR HAVE PRE-EXISTING HEALTH, AND/OR ORTHOPEDIC MEDICAL CONDITIONS. YOUR PHYSICIAN CAN HELP YOU DETERMINE WHAT ACTIVITIES OR PROGRAMS ARE MOST SUITABLE FOR YOU.

## WARRANTY

This is to certify that the Pilot© wireless cadence meter is warranted by LeMond Fitness Inc. to be free of all defects in materials and workmanship. This warranty does not apply to any defect caused by negligence, misuse, accident, alteration, improper maintenance, or an "act of God." The Pilot cadence meter can only be used on the Rev-Master indoor cycling bike. Any attempts to use this meter on any other equipment voids the warranty.

The Pilot carries a one year warranty on the meter and transmitter. Batteries are not warranted. Contact our Customer Service Department to report any problems. When calling, please be prepared to provide the customer service representative with the following information: Your name, the serial number of the inoperable unit, and the date(s) of purchase for the meter. If warranty replacement parts are shipped to you, you may be required to return the inoperable part.

LeMond Fitness Inc. neither makes, assumes nor authorizes any representative or other person to make or assume for us, any other warranty whatsoever, whether expressed or implied, in connection with the sale, service, or shipment of our products. We reserve the right to make changes and improvements in our products without incurring any obligation to similarly alter products previously purchased. In order to maintain your product warranty and to ensure the safe and efficient operation of your cadence meter, only authorized replacement parts can be used. This warranty is void if parts other than those provided by LeMond Fitness are used.

### SPECIFICATIONS

#### Cadence Meter

Heart Rate Range:	30 to 240 bpm (beats per minute)
Heart Rate Accuracy:	± 4 bpm
Battery:	2 AA batteries
Battery Life:	6 months to 1 year, depending on usage

#### Transmitter

Emitted Frequency:	122 kHz
Battery:	3 AA batteries
Battery Life:	6 months to 1 year, depending on usage

## CONTENTS

Description . . . . .	7
Installation of the Pilot	
Batteries . . . . .	8
Console . . . . .	10
Transmitter. . . . .	10
Display Window . . . . .	12
Quick Start Program. . . . .	14
Custom HR Training and Calorie Calculation . . . . .	15
Key Functions . . . . .	17
Cadence Training. . . . .	20
Troubleshooting . . . . .	22
Appendix	
FCC Compliance. . . . .	24
Changing the Console and Transmitter Codes. . . . .	25
Dip Switch Codes . . . . .	26
Console Commands . . . . .	27

### NOTE:

- Press any key to turn on the Pilot console.
- Never disassemble the console or transmitter as it can not be reassembled.
- The console is water resistant, not water proof. Do not deliberately place it in water.
- To clean the console, wipe it off with a clean rag sprayed with diluted household cleaner.

## DESCRIPTION

The Pilot assembly consists of a console and a transmitter. A sensor in the transmitter counts the number of times a magnet mounted in the crank pulley passes the sensor. The transmitter then sends a coded RF (radio frequency) signal to the console containing the measured values.

The console has inboard receivers that pick up the signals from the transmitter and heart rate signals from (telemetry) from the chest strap. The heart rate is then shown in the display window. The console will track cadence (RPMs), speed (MPH/KPH), time, distance, and caloric expenditure.

The console and the transmitter use AA batteries as a source of power. Install the supplied batteries in the console and in the transmitter prior to using.

### NOTE:

- Excessive use of the back light [  ] will drain the console batteries prematurely.
- Expected life of the console batteries is 6 months to 1 year.
- If the console battery power is low, then "BATT LOW" will be shown in the display window for 2 seconds after the display is turned on to inform you to change the console batteries.
- Expected life of the transmitter batteries is 6 months to 1 year.

## INSTALLATION OF THE PILOT

**NOTE:**  
THE CADENCE METER CAN ONLY BE INSTALLED ON A  
LEMOND REVMASTER BIKE.

To install the meter (console and the transmitter), you will need the following tools:

- Phillips Screwdriver
- 2.5-mm Hex Key (supplied)
- 3-mm Hex Key (supplied)
- 4-mm Hex Key (supplied)

### Console Battery Installation:

1. Loosen the battery cover screw and remove the battery cover from the console.
2. Insert 2 AA batteries into the battery compartment and reinstall the battery cover.

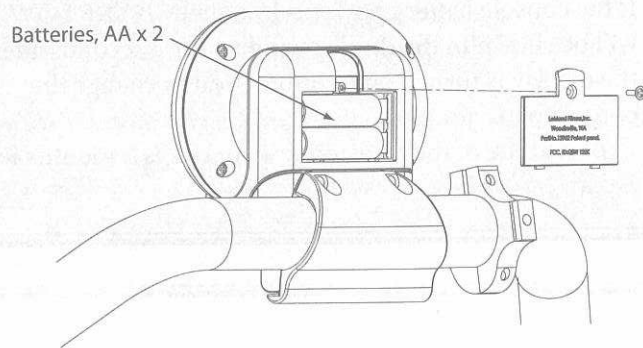

## INSTALLATION OF THE PILOT

### Transmitter Battery Installation:

1. Remove the battery cover from the transmitter with a 2.5-mm hex key.
2. Install 3 AA batteries in the battery compartment.
3. Retain the battery cover and its screw until you have installed the transmitter on the bike. You will reinstall the battery cover at that time.

