





Dahua 5.8GHz Wireless AP/CPE User Manual

Version : 1.0.0

Zhejiang Dahua Technology CO., LTD

 File Version Description Sheet 1 Version Description

Version	Release Time	Revised Chapters	Author
1.0	2014-05-12	Establish	cl

 Reference Materials Manual Purposes

The manual mainly provides the users with some help to get familiar with DH-PFM88X and how to use DH-PFM88X; especially they can solve some common problems when some troubles occur to the device. The manual is mainly involved in DH-PFM88X hardware info, various parameters of webpage, configuration mode, networking mode, malfunction analysis and some other aspects, which can effectively help users to get familiar with the usage of the device quickly and shorten the time of entry Bridge series products for users.

 Statement

The right of final explanation of this file belongs to Zhejiang Dahua Technology CO., LTD; our company is not liable for any damage of the device caused by unauthorized use.

 Noun Definition and Acronym Description Sheet 2 Noun Definition and Acronym Description

SN	Definition or Acronym	Description
1	DH-PFM880	Long-distance wireless transmission server AP
2	DH-PFM881	CPE client

Table of Contents

1	Product Overview.....	- 1 -
1.1	Product Introduction	- 1 -
1.2	Electrical Specifications	- 4 -
1.3	Product Packaging List	- 6 -
1.4	Product Features	- 6 -
1.5	Application Range	- 7 -
1.6	Hardware Description	- 8 -
1.7	Hardware Description	- 8 -
2	Product Installation	- 10 -
2.1	Line Connection.....	- 10 -
2.2	Restore Default Factory Setting.....	- 11 -
3	Quick Configuration	- 12 -
3.1	Log In	- 12 -
3.2	Device Quick Configuration through Setting Wizard.....	- 13 -
4.	TDMA.....	- 18 -
5.	Status Display.....	- 19 -
5.1	Status Display	- 19 -
5.2	Real-Time Monitoring	- 20 -
6.	Wireless Setting	- 22 -
7.	Network Setting.....	- 23 -
7.1	Route Mode	- 23 -
7.2	Bridge Mode.....	- 25 -
7.3	Firewall.....	- 25 -
8.	Advanced Settings	- 27 -
9.	System Settings	- 29 -
10.	Tools Application	- 30 -
11.	Common Networking Mode	- 33 -
11.1	Wireless Point-to-Point	- 33 -
11.2	Wireless Point-to-Multipoint.....	- 34 -
11.3	Wireless Coverage Blind Angle Adjustment Mode	- 35 -

11.4 Route Mode Networking..... - 36 -

12. FAQ - 38 -

13. Construction attention for wireless bridge and monitoring. - 40 -

13.1 Construction attention..... - 40 -

13.2 Test Situation - 41 -

13.3 Reference Setting:..... - 42 -

1 Product Overview

DH-PFM88X series device is a device with unique built-in TDMA wireless technology, which integrates industry-leading core technology and has the features of long distance transmission, high throughput rate and strong anti-interference.

TDMA, 20M/40MHz bandwidth flexible configuration, rate control, ACK overtime auto adjustment and etc. TDMA effectively solved the problem of hidden node which bothers large-scale point-to-multipoint WLAN. 20M/40MHz bandwidth flexible configuration achieved a balance between scarce wireless bandwidth resource and complex working scenario. Advanced rate control algorithm can quickly adapt to channel quality change and at the same time keep the rate stable as much as possible. Auto ACK-Timeout Adjust technology can auto detect the distance between access point and client; adjust wireless parameter to optimize the device performance.

DH-PFM880 max transmission distance can reach 5km, max transmission rate can reach 300Mbps, and it also has excellent long-distance transmission performance, It can be used as wireless bridge between point-to-point and point-to-multipoint remote access, and a base station AP for WI-FI wireless coverage.

1.1 Product Introduction

PFM has the most advanced design technology in the industry; compact body contains base station and wireless transmission effect and an advantage of high performance.

This equipment has been tested and found to comply with the limits for a Class B digital device, pursuant to Part 15 of the FCC Rules. These limits are designed to provide reasonable protection against harmful interference in a residential installation. This equipment generates, uses, and can

radiate radio frequency energy, and if not installed and used in accordance with the instructions, may cause harmful interference to radio communications.

However, there is no guarantee that interference will not occur in a particular installation. If this equipment does cause harmful interference to radio or television reception, which can be determined by turning the equipment OFF and ON, the user is encouraged to try to correct the interference by one or more of the following measures:

Reorient or relocate the receiving antenna

Increase the separation between the equipment and receiver

Connect the equipment into an outlet on a circuit different from that to which the receiver is connected

Consult the dealer or an experienced radio/TV technician for help.

The manufacturer is not responsible for any radio or TV interference caused by unauthorized modifications to this equipment. Such modifications could void the user's authority to operate the equipment.

To satisfy FCC RF exposure requirements for mobile and base station transmission devices, a separation distance of 20 cm or more should be maintained between the antenna of this device and persons during operation. To ensure compliance, operation at closer than this distance is not recommended. The antenna(s) used for this transmitter must not be co-located or operating in conjunction with any other antenna or transmitter.

Integrated advanced TDMA, MIMO and other advanced technologies. Innovative compatibility and improvement of 802.11n protocol guaranteed long distance, throughput rate and anti-interference ability of device wireless transmission. DH-PFM88X series wireless device owns following advantages compared with other brand products:

1. Integrated Technology

DH-PFM88X with built-in operating system integrated TDMA, which effectively solved the problem

of hidden node which bothers large-scale point-to-multipoint WLAN. Operating system adopts advanced rate control algorithm which can quickly adapt to channel quality change and at the same time keep the rate stable as much as possible. It is suitable for long-distance wireless transmission and solved the problem of long-distance point-to-point access, which makes more access number and rate distribution more average, which is fit for the application of operator and wireless monitoring field.

2. Long Transmission Distance, High Throughput Rate

DH-PFM88X max transmission distance can reach 5km, max transmission rate can reach 300Mbps, and it also has excellent long-distance transmission performance, Its long-distance transmission and high performance can meet the users' demand of high bandwidth and long-distance communication.

3. Integrated Watchdog

DH-PFM88X integrated hardware watchdog which monitors system operation all the time. Once the system works abnormally, watchdog will reset the system and make it restart, which effectively guarantees the stability of DH-PFM88X.

4. Ping Watchdog Function Real-time Detect Link

Ping Watchdog function can detect if the link works normally, it will help to restart the device when malfunction occurs to the link, which guarantees stability of the link.

5. A great number of frequencies provided to users

Currently most wireless products are working in standard 802.115.8G frequency, but the standard 5.8G frequency band is relatively less. 5.8G device will be more susceptible to interference when the use of 5.8G device is very extensive. However, DH-PFM88X products increased support for 5.8G nearby frequency, which will make the working frequency expand to 4920MHz-6100MHz. Because the interference of some frequencies is very little, the client working in these frequencies and performance of access point are better than other frequencies. DH-PFM88X's support for

non-standard frequency reduced the interference from outside wireless products and effectively improved the throughput rate of DH-PFM88X, which will meet users' demand for high bandwidth.

Attention: Please confirm if it conforms to local laws and regulations and radio management regulations before using these non-standard frequency bands.

6. Adapt to complex working environment

DH-PFM88X can work in complex environment, working temperature is between -30°C and 70°C, working humidity is between 5% and 95%. DH-PFM88X can still maintain high throughput rate if it works in thunderstorm, high temperature high humidity, low temperature low humidity and other severe weather conditions for a long time.

1.2 Electrical Specifications

See sheet 3 for the electrical specifications of DH-PFM88X.

Type	Item	DH-PFM880	DH-PFM881
Wireless Technology	Standard	IEEE802.11 a/n	
	Modulation Mode	802.11 a/n: OFDM	
	Antenna	External antenna: gain 16dBi	Built-in antenna: gain 15dBi
	Equivalent Output Power	+9dBm(@MCS0,11n)	+9dBm(@MCS0,11n)
	Receiving Sensitivity	-74dBm @ 65Mbps, -96dBm@1Mbps	
	Optimal Transmission Distance	0-3KM	0-5KM
	Working Frequency Band	5.725GHz~5.85GHz	
	Wireless Authentication	SRRC	
	Wireless Direction Angle	Horizontal 90° , vertical 12°	Horizontal 40° , vertical 15°
	Transmission Rate	11n:13.5/15/27/30/40.5/45/54/60/81/90/108/120/121.5/135/150/162/180/216/240/270/300Mbps (40MHz Channel width) 11n : 130/117/104/78/65/58.5/52/39/26/19.5/13/6.5Mbps (20MHz Channel width)	

		11a : 54/48/36/24/18/12/9/6Mbps(self-adaption)	
Hardware	Power Module Port	1*POE RJ45(IN: 220V, OUT: 24V/0.5A)、1*LAN RJ45	
	Power Consumption	MAX 10W	MAX 8W
	Port	1*POE RJ45	1*POE RJ45、1*LAN RJ45
	Indicator Light	N/A	Wi-Fi status indicator light / LAN port indicator light / Power indicator light / Signal intensity indicator light
	Working Temperature	-30℃~+70℃	
	Storage Temperature	-30℃~+80℃	
	Working Humidity	5%~95%RH(no condensation)	
	Equipment Dimension(mm)	233×233×45mm	280×30×80mm
	Antenna Dimension(mm)	450×140×35 mm	N/A
	Equipment Weight	2.4Kg	0.45Kg
	Antenna Weight	1.26Kg	N/A
	Protection Level	IP66	N/A
	Mast Diameter	40mm~60mm	
Software	Encryption Way	WEP/WPA-PSK/WPA2/CCMP(AES)/TKIP	
	Network Mode	Route/Network Bridge	
	Working Mode	Access Point/Client/WDS AP/WDS client/WDS Repeater	
	Security Mechanism	IP/MAC address filtering, hide network name and etc	
	Network Protocol	TCP/UDP/ARP/ICMP/DHCP/HTTP/NTP	
	TDMA Enhancement	Support (TDMA eliminate hidden nodes influence and greatly improve one-to-many performance)	
	Auto ACK-Timeout Adjust	Support (Auto optimize parameter within long-distance communication and make the performance optimal)	
	Management and Log	NTP, SNMP, Syslog, Telnet	
	Webpage Configuration Management	Support webpage configuration	
	Firmware Update	Support Firmware webpage update	
	Channel Width	20M/40MHz	

1.3 Product Packaging List

DH-PFM880

- Host *1;
- Antenna *1
- Feeder line *2
- POE power supplier (24V/0.5A)*1;
- Quick configuration manual;
- Compact disc;
- Accessory

DH-PFM881

- Host *1;
- POE power supplier (24V/0.5A)*1;
- Quick configuration manual;
- Compact disc;
- Ribbon *2;

1.4 Product Features

- Adopt high performance 802.11n 2X2 MIMO chip, max rate 300Mbps, outdoor max transmission distance 5km
- Support five working modes: AP, Station, AP-WDS, Station-WDS, Repeater-WDS

- Use unique TDMA technology, intelligent rate control, auto ACK overtime adjustment and some other technologies.
- TDMA protocol overcame 802.11 inherent problem of inherent node, which makes the product have better long-distance and point-to-point performance.
- Support point-to-point and point-to-multipoint transmission modes.
- Exclusive antenna, radio-frequency amplifier, low noise receiver design, ensure long-distance video, audio and data transmission.
- Customize common scenario and working mode for users, make it convenient for non-wireless professionals to use and install.
- Exclusive TDMA technology can maximize the use of bandwidth resource and better support point-to-multipoint data transmission.
- POE power supply, support international universal 802.3af standard, power supply mode is more convenient and reliable.
- Remote control and management through webpage, easy for configuration.
- Water-proof and ultraviolet-proof cover ensures outdoor stable operation for the device.

1.5 Application Range

1. Safe towns, safe construction sites, safe scenic area
2. Playground, ranch, uptown crossroad and other no blocking scenarios.

1.6 Hardware Description

See sheet 4 for the simple hardware information of DH-PFM88X:

Hardware Index	
CPU/Baseband Radio	Atheros AR7240/AR9280
Memory	32MB DRAM, 8MB Flash
Physical Port	2 × 10/100M Base-TX (Cat. 5/5E, RJ-45)Internet access(DH-PFM881) 1 × 10/100M Base-TX (Cat. 5/5E, RJ-45)Internet access(DH-PFM880)
LED Indicator Light	Power, LAN, WLAN, 3×Link Quality(DH-PFM881)
Power Supply	POE, Power Adapter 24V/0.5A

Sheet 4

1.7 Hardware Description

In order to make users not have to login webpage, and let them have a rough idea of current working situation of DH-PFM881 intuitively with naked eyes, DH-PFM881 adopts LED to show current working condition and connection quality. LED is mainly divided into two parts, one is device status, and the other is connection quality. See Figure 1 for more details, the first LED from left is power indicator, the second is network indicator, the third is connection indicator; the first to the third from right are signal intensity indicator, see sheet 5 for more details.



Figure 1

LED	Color	Status
POWER	Green	Light on means DH-PFM881 connected power
LAN	Green	Light on means DH-PFM881 LAN port is connected to external device
WLAN	Green	Light on means wireless of DH-PFM881 is enabled. Flashing light means the device wireless is enabled and transmitting data by wireless.
Signal Intensity	Red	Indicator shows the signal intensity
	Yellow	Green light on means high signal intensity
	Green	Yellow light on means medium signal intensity Red light on means weak signal or no signal

2 Product Installation

The line connection mode is different under different network mode, because the device default setting is bridge mode. This chapter mainly describes the line connection mode of bridge mode, please refer to chapter 7 network setting for the connection mode of route mode.

2.1 Line Connection

See Figure 2 for the installation of DH-PFM881.

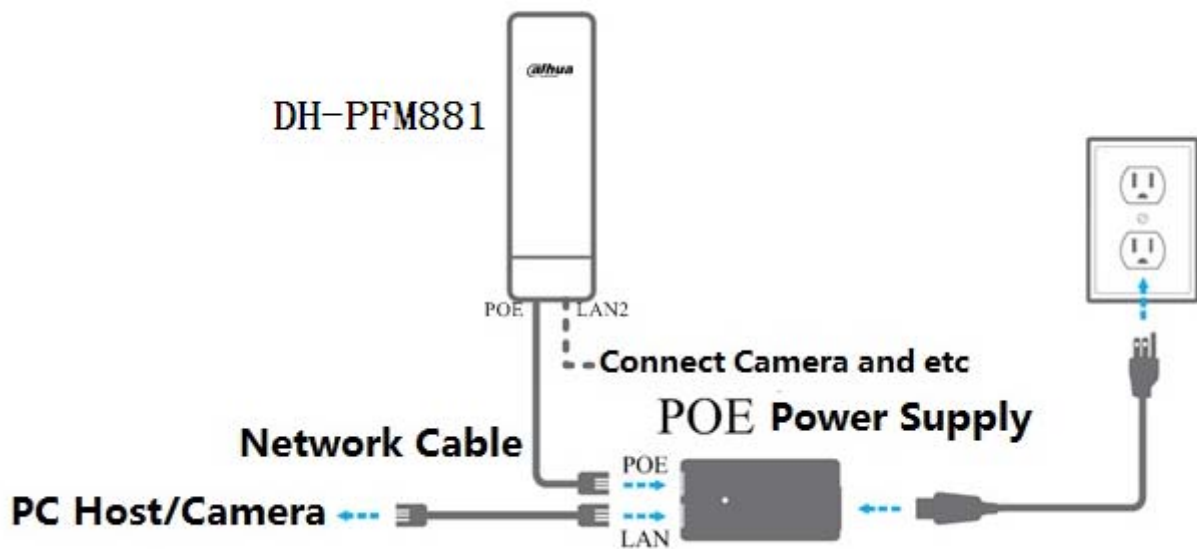

Figure 2

DH-PFM881 device has two internet accesses (RJ45 ports), which are marked as “POE” and “LAN2” respectively. The device default setting is bridge mode, so “POE” port is connected to POE power port by network cable and provides DH-PFM881 device with 24V power and data connection. “LAN2” port can be linked to IP Camera (such as video surveillance application) and other devices.

2.2 Restore Default Factory Setting

We can choose manual operation when users forget the IP of DH-PFM881 and can't open the webpage. See Figure 3 for more details; press Reset button for 5-10 seconds, let go when all the LED lights are on, and the device has been restored default factory setting. Meanwhile, the port with direct connection with DH-PFM881 host will show twice connection and disconnection in a row.

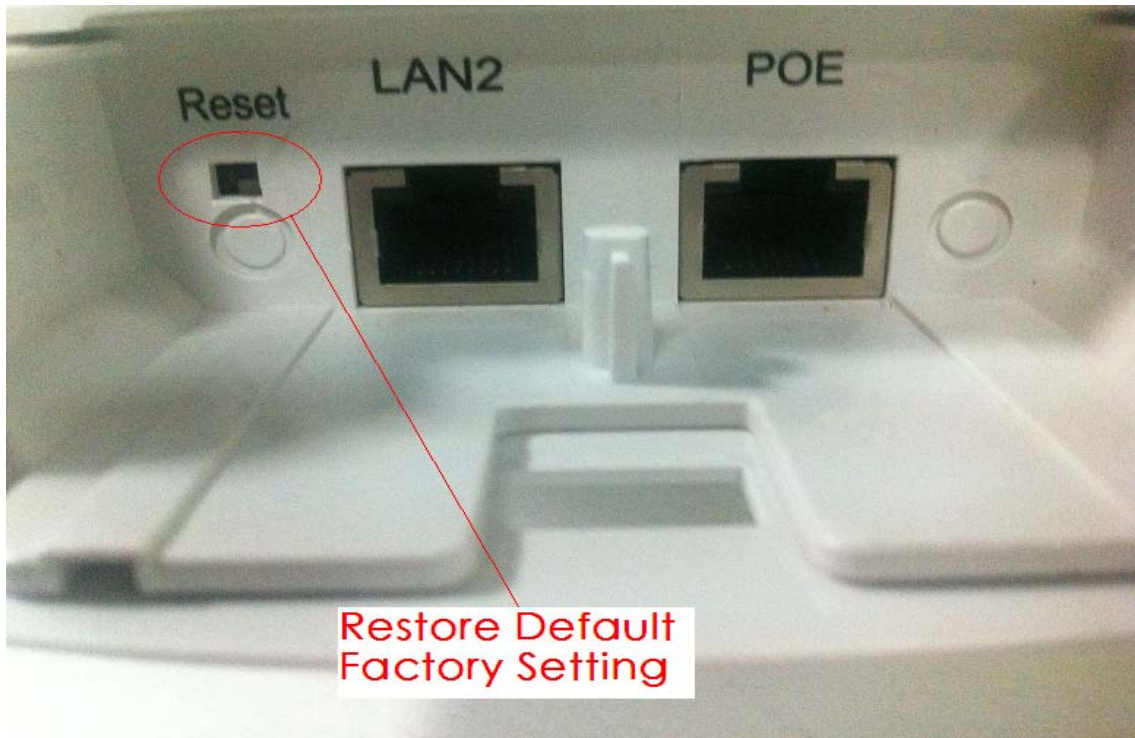

Figure 3

See sheet 6 for main parameters of DH-PFM881 default factory setting

Item	Default Factory Setting
IP Address	192.168.1.36
User Name	admin
Password	admin
Way of Encryption	WPA->WPA2->CCMP->PSK Key: 1234567890abc
Network Mode	Bridge Mode

3 Quick Configuration

This chapter mainly describes how to make quick configuration to Bridge device and make it work normally.

3.1 Log In

Login DH-PFM88X configuration work is made up of setting the host which connects DH-PFM88X directly and log in, operation steps are as follows:

1. Network connection->local connection, select local connection and single click right button, click properties by mouse left button.
2. Select Internet protocol (TCP/IP), double click with mouse left button, you will see the window shown in Figure 4.

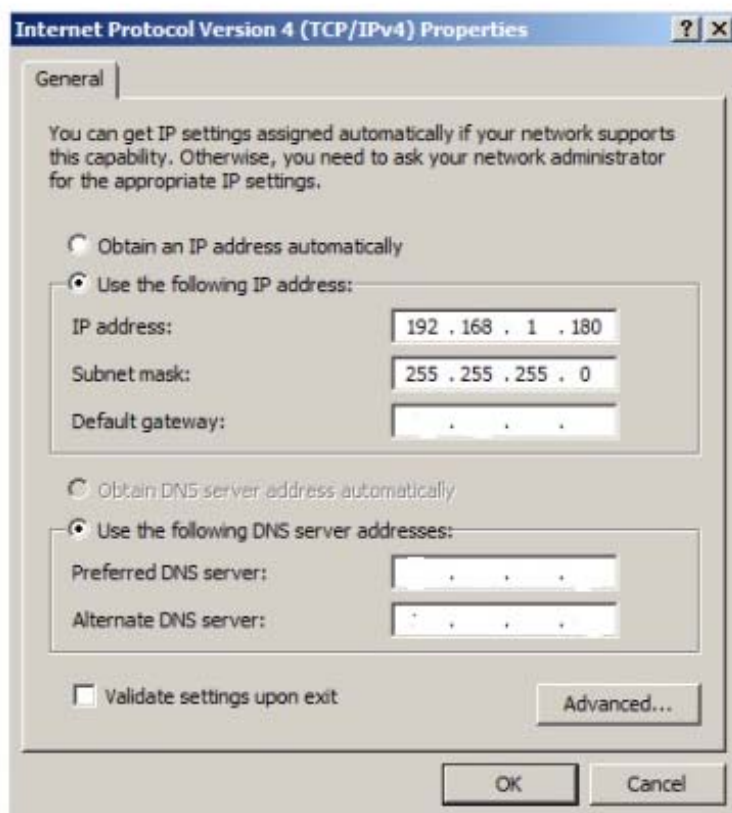

Figure 4

3. IP address is set the same network segment IP of DH-PFM88X, which is shown in Figure 4, and the IP can't be the same as DH-PFM88X. For example: the IP of DH-PFM88X is 192.168.1.36, then the host IP can be set as 192.168.1.180; meanwhile, different DH-PFM88X devices need to be allocated with different addresses so as not to cause address conflict.

4. Input DH-PFM88X IP in the browser and press enter key, enter the login interface, default user name and password are admin\admin;

3.2 Device Quick Configuration through Setting Wizard

Users can make quick configuration to Bridge device by setting wizard in this chapter.

1. The first page is "Status Display" After login (see Figure 5); it shows the current working status, current setting and software version of DH-PFM88X. Other pages can be displayed by clicking the menu on the left, as shown in Figure 6.

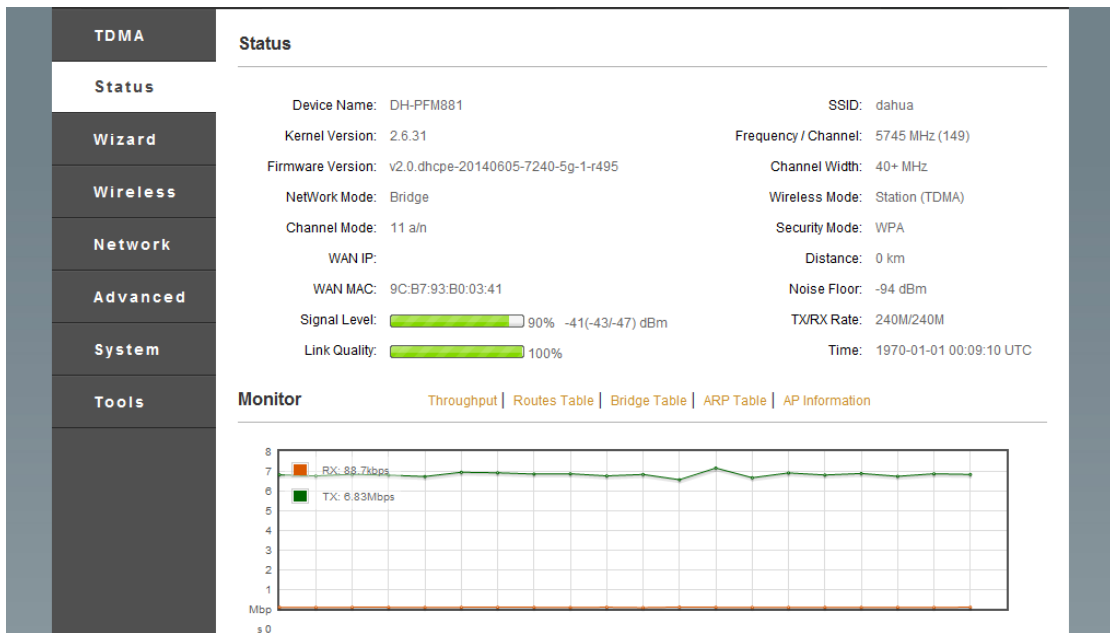

Figure 5

2. Click “Setting Wizard” on the left, as shown in Figure 6. The wizard can help users to make quick configuration to the device, such as network configuration, wireless mode and etc.

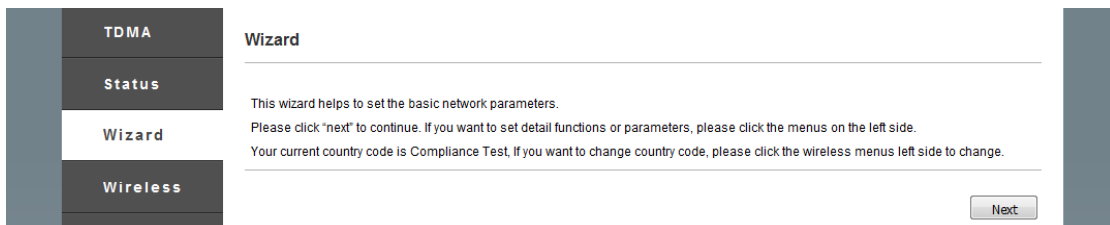

Figure 6

3. Click “Next”, it will display basic network parameter configuration. Device default configuration is “Bridge Mode”, LAN port IP address is “192.168.1.36”, as shown in Figure 7. If users need to configure the device as “Bridge Mode” and other detailed network setting, please click the “Network Setting” menu on the left after completing setting wizard.

Attention: If several DH-PFM88X devices realize interconnection of point-to-point or point-to-multipoint, different devices need to be configured with different IP address.

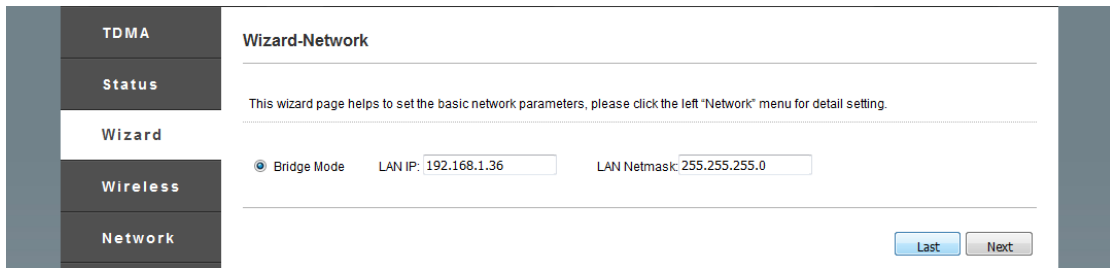

Figure 7

4. Click “Next” and it will display basic wireless mode and wireless security options, as shown in Figure 8. Two of most commonly used wireless mode of DH-PFM88X device are “client” and “access point”.

Configured as “client” (Station) mode: It means DH-PFM88X device can be connected to DH-PFM88X device of “access point” mode.

Configured as “Access Point” (AP) mode: It means DH-PFM88X device can be connected to DH-PFM88X device of “client” mode.

The precondition is that configuration between wireless encryption option of wireless connection for both sides and network name should be in accordance with each other. Please click “wireless Setting” menu on the left if you need other detailed wireless configuration.

Attention: If you need one-to-one (one-to-many) device interconnection and transmit audio or data, the center device needs to be configured as “Access Point” while other devices configured as “client”, and configured with same way of encryption, then let “Access Point” device connect to “Client” device, in this way audio or data transmission can be done.

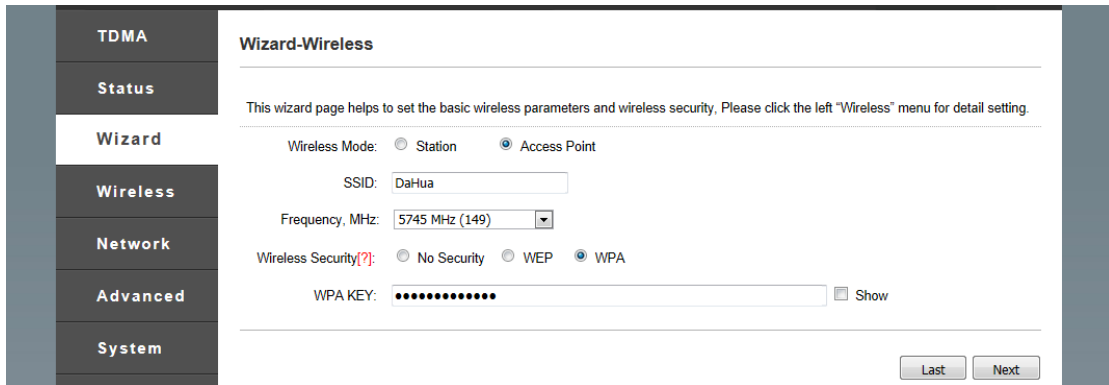

Figure 8

5. Click “Next” and it will display working scenario option, as shown in Figure 9. Please enable “custom scenario” if the users need to customize working scenario, then click “Next” to display custom scenario configuration. If users enable other options and click “Next”, the completion page of setting wizard will occur.

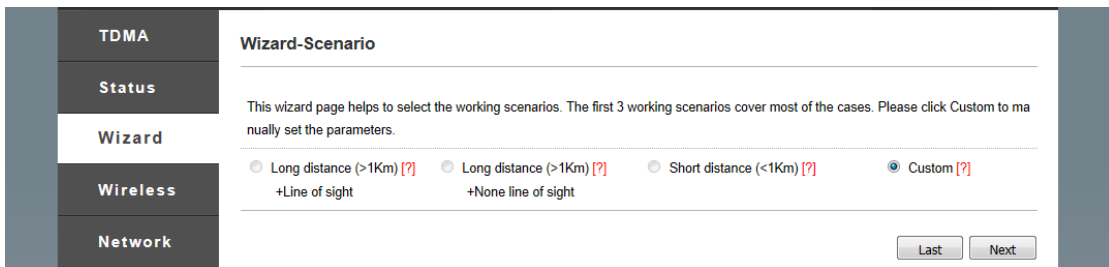

Figure 9

6. In the page “setting wizard-custom scenario”, as shown in Figure 10. The following several option setting will affect the device performance:

Output Power: Users need to configure the device output power according to the actual working situation and local laws and regulations, the bigger output power is, and the longer wireless transmission distance will be (The system supports max output power 9 dBm).

Channel Width: default is 20MHz, to reach optimal wireless transmission rate. It is recommended to use channel width 10MHz under the environment of serious block and long-distance communication (>1km) to improve the quality of wireless transmission.

Auto ACK-Timeout Adjust: Users are recommended to open “Auto ACK-Timeout Adjust”, this option can auto test the distance between two devices and set parameters according to this distance to optimize wireless connection quality.

Distance: If “Auto ACK-Timeout Adjust” option is open, then the distance setting will become invalid, system will auto test device distance and optimize connection quality. Users need to close “Auto ACK-Timeout Adjust” option if they want to make the distance which is set by themselves take effect.

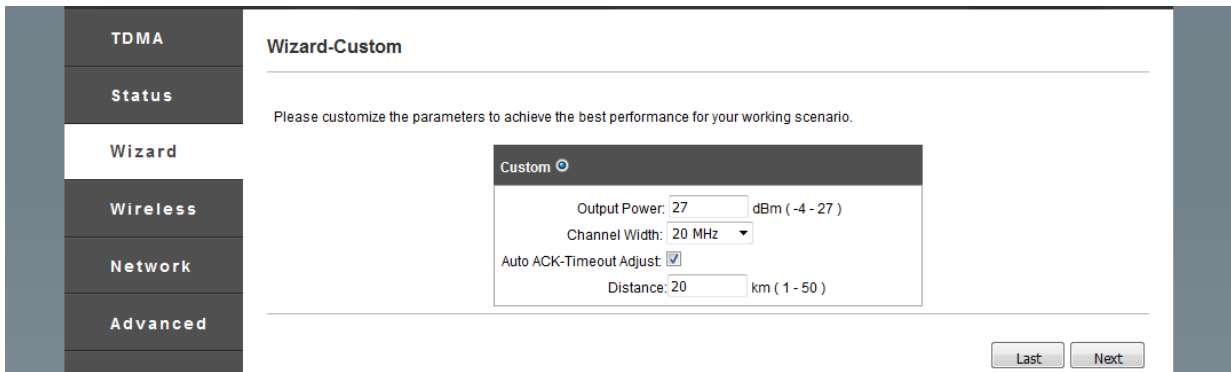

Figure 10

7. The last page is “Setting Wizard-Finish”, as shown in Figure 11. Users can click “change” button to save all the settings, then click “Apply” button to make your settings valid; or click “apply” to modify previous configuration.

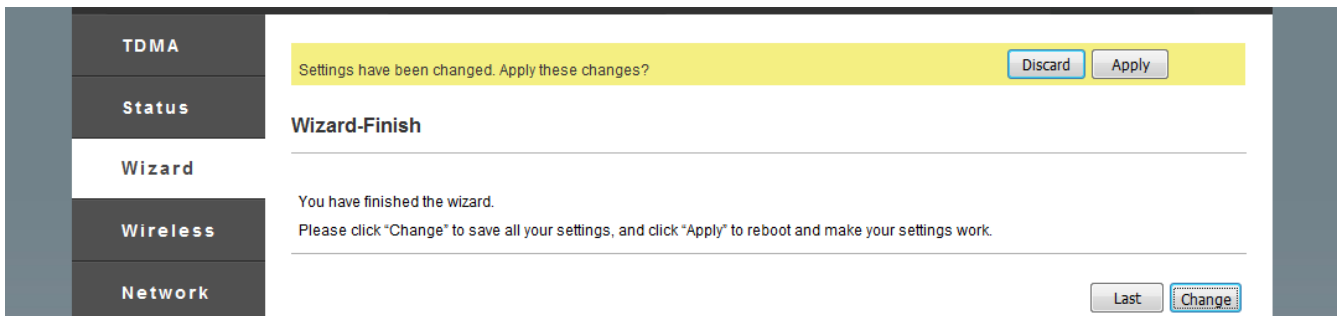

Figure 11

4. TDMA

Currently, most long-distance wireless broadband network bridge products developed from 802.11 WLAN technologies. The built-in operation system integrated TDMA, 20M/40MHz bandwidth flexible configuration, rate control, Auto ACK-Timeout Adjust and several other industry-leading technology, which is an ideal product of long-distance wireless broadband access. Among those, TDMA effectively solved the problem of hidden node which bothers large-scale point-to-multipoint WLAN. 20M/40MHz bandwidth flexible configuration achieved a balance between scarce wireless bandwidth resource and complex working scenario: narrower wireless bandwidth configuration is used in the situation where there are less free wireless channels and a single user wireless access rate requirement is not high; wider wireless bandwidth configuration is used under the situation where there are more free wireless channels and single user wireless access rate requirement is high. Besides the narrower wireless bandwidth configuration is more effective in the environment with block. Operation system adopts advanced rate control algorithm which can quickly adapt to channel quality change and at the same time keep the rate stable as much as possible, which is very suitable for long-distance wireless transmission. Auto ACK-Timeout Adjust technology can auto detect the distance between access point and client; adjust wireless parameter to optimize the device performance. See Figure 12 for client TDMA.

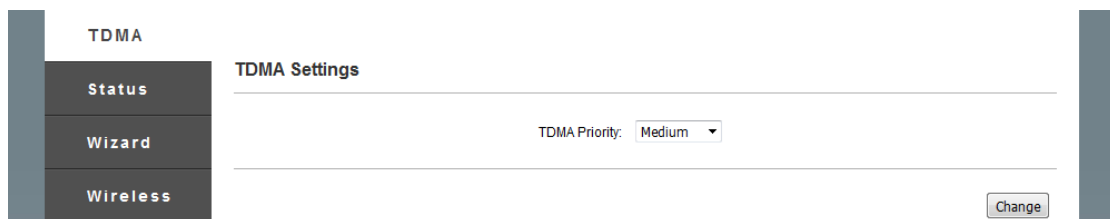

Figure 12

When you enable TDMA function, AP end needs to enable TDMA, client needs to set a priority. Different clients ask for different demand for bandwidth when one AP links to several clients, but the setting of priority is done according to clients' demand of bandwidth for current device. We recommend users to set priority as high if the demand for bandwidth is high, otherwise, priority should be set as low priority. Anyway, all the clients' priority can be set same if they have the same demand for bandwidth.

Attention: The TDMA of AP and client should both be open when you want to enable TDMA function.

The TDMA from other factories can't communicate with our TDMA. If both our device and device from other factories enable TDMA, then both sides can't be connected.

5. Status Display

Status Display is the first page after the users log in, the page displays current configuration of the current device and current working condition of real time monitoring. It is located in the second item of the menu bar; see Figure 13 for more information.

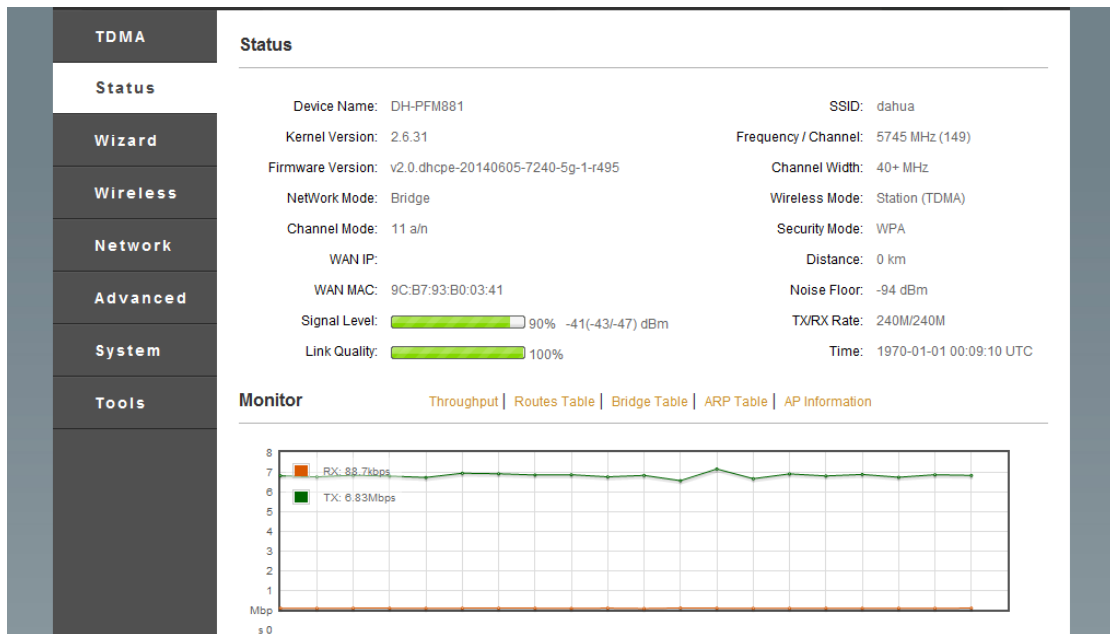

Figure 13

5.1 Status Display

It shows current configuration information on the status display page, which shown in sheet 7

Item	Function	Item	Function
Device Name	DH-PFM88X	Kernel Version	2.6.31
Firmware Version	Software Version	802.11 Mode	The current 802.11 protocol
WAN IP	WAN port IP address with route mode	WAN MAC	WAN port MAC address with route mode

Network Mode	Operation mode, route mode or bridge mode	SSID	Name of wireless network
Frequency/Channel	Communication channel	Channel width	Four types: 5M、10M、20M、20/40M AUTO
Wireless Mode	Client, access point, WDS client, WDS access point, WDS repeater	Security Mode	Several ways of encryption for wireless
Distance	The distance between client and access point which are interconnected	Noise Floor	Interference from external environment
Signal Level	Parameter for Client, WDS client, WDS repeater, which indicates the total signal intensity of client and the signal intensity of up and down two way for client	Link Quality	The quality of link connection
TX/RX Rate	Parameter for client, WDS client, WDS repeater, which indicates the momentary rate of sending/receiving data for current device	Time	Time display. Time will auto update to calibration time from NTP service when NTP client is enabled and NTP service is set right. There will be a default if you can't log on the Internet.

Sheet 7

5.2 Real-Time Monitoring

Throughput Rate: Throughput rate is also called throughput capacity, which means the data volume passing through each section in unit time while the throughput rate on status display page means the data volume transmitting through network in unit time, which is the main index to measure network performance. Users can also real time monitor the rate of device transmitting data volume by it. See figure 14 for more information.

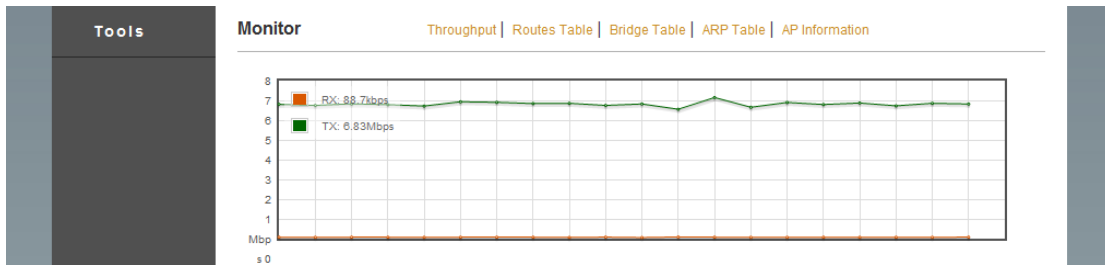

Figure 14

Routes Table: The routing list stores the paths which point to the network for DH-PFM88X device. See Figure 15 for more information.

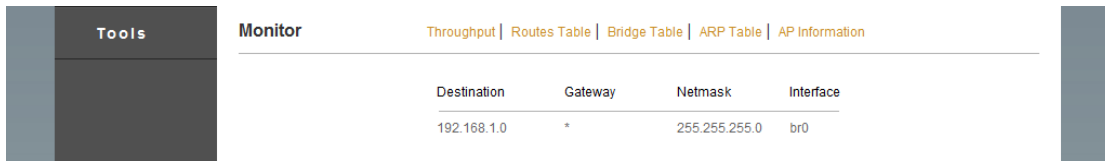

Figure 15

Bridging Table: PFM 88X acquired the corresponding relation between device MAC address which communicate though it recently and aging time.

ARP Table: The device acquired the corresponding relation between used IP address which communicate through LAN port recently and MAC address.

Access Point/Client information sheet: When the device is used as AP mode and it connected a client, then you can see the client information shown in Figure 16.

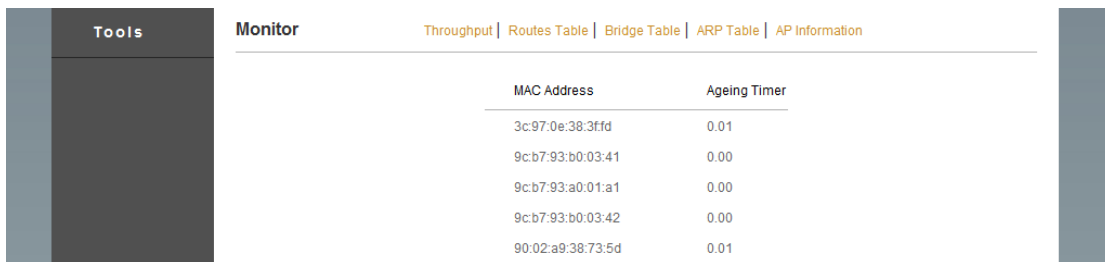

Figure 16

When the device is used as client mode, and it connected an AP, then it will display AP information shown in Figure 17.

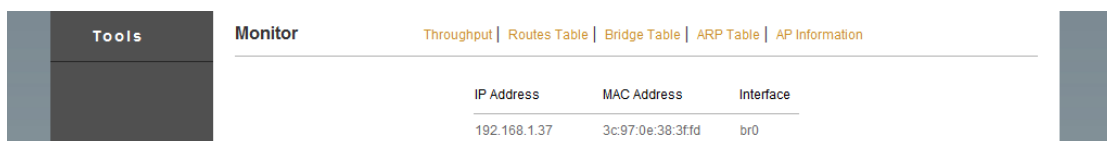

Figure 17

6. Wireless Setting

More information about wireless setting.

There are five types of wireless mode of the device: AP mode, client mode, WDS client mode, WDS Repeater

AP : Client device like computer, cell phone, wireless bridge and etc can connect to wireless access node. One AP can connect several clients.

CPE/Client: It needs to be used cooperatively with AP, it connects to AP. One client can only connect to one AP.

WDS Client: Same as client can only connect to WDS access point or WDS repeater, and one WDS client can only be connected to one WDS access point or WDS repeater.

WDS Access Point: Can only connected to WDS repeater or WDS client, meanwhile one WDS access point can connect to several WDS client or WDS repeater.

WDS Repeater: Can connect to WDS client or WDS repeater at the same time.

SSID: Used to control the value of access to wireless network. When other devices try to connect to this device, only with same setting of SSID can they realize intercommunication and build LAN.

As shown in Figure 20, users can search the names of surrounding wireless network by click “select” on the right of network name, and then connect to corresponding wireless network according to his own demand.

Frequency: Center frequency of carries wave, bandwidth is the left-right offset of the center frequency. It needs to be set parameter when it is used as AP mode. Users can select several frequencies when it is client mode. Client can't connect to AP when the frequency of AP is not the frequency selected by client. Only when the frequency of AP is one of the frequencies selected by client can they be interconnected.

Output Power: Users can adjust the output power of device transmitting wireless signal according to the distance between devices. The transmitted signal distance and intensity will improve when output power goes up.

Channel Width: It means max data transmission rate of the channel.

Max TX Rate: Limit the device max send/receive rate by setting it and keep the stability of device performance by doing so.

Root Access Point MAC Address: Client, WDS Repeater or WDS client can limit the object that the device is to connect by setting it.

Wireless Security Setting: Make encryption to wireless connection, users can select corresponding encryption way according to their own demand for safety. The devices which are to be interconnected need to be set the same wireless encryption, otherwise, they won't be interconnected.

WEP: Wired equivalent encryption technology, a data encryption technology.

WPA: A kind of specification based on standard to enhance the interoperable safety, which has greatly increased the control level of data protection and access in the existing and future WLAN system. It is designed into the form of software upgrading and run on the existing hardware, Wi-Fi Protected Access is from and will be compatible with the future IEEE 802.11i standard. After it is installed correctly, it will provide users of wireless network with high-level protection, which will always make their data protected and it is only open to those authorized network users. WPA made up all the defects of WEP.

7. Network Setting

7.1 Route Mode

DH-PFM88X is used as a router when it is under route mode; it has WAN port and LAN port. At this moment, the LAN2 of DH-PFM88X is equivalent to the LAN port of router while the LAN port on POE

power supplier is equivalent to the WAN port of router. See Figure 19 for its line connection when it is under route mode.

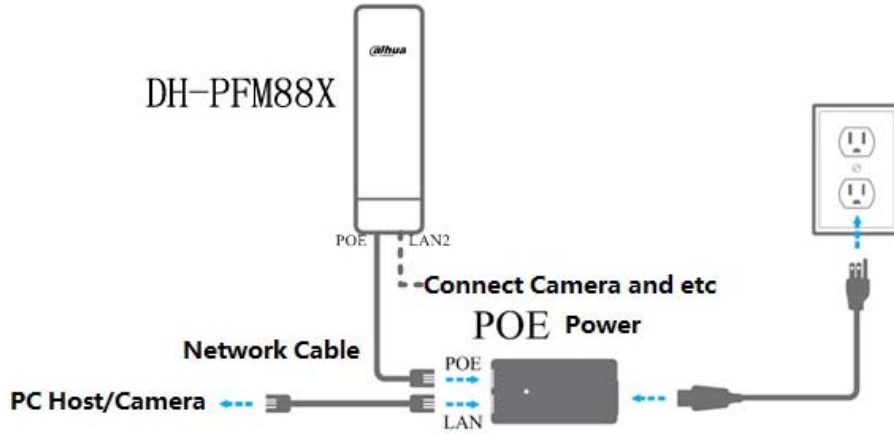

Figure 19

See Figure 20 for more information about router mode.

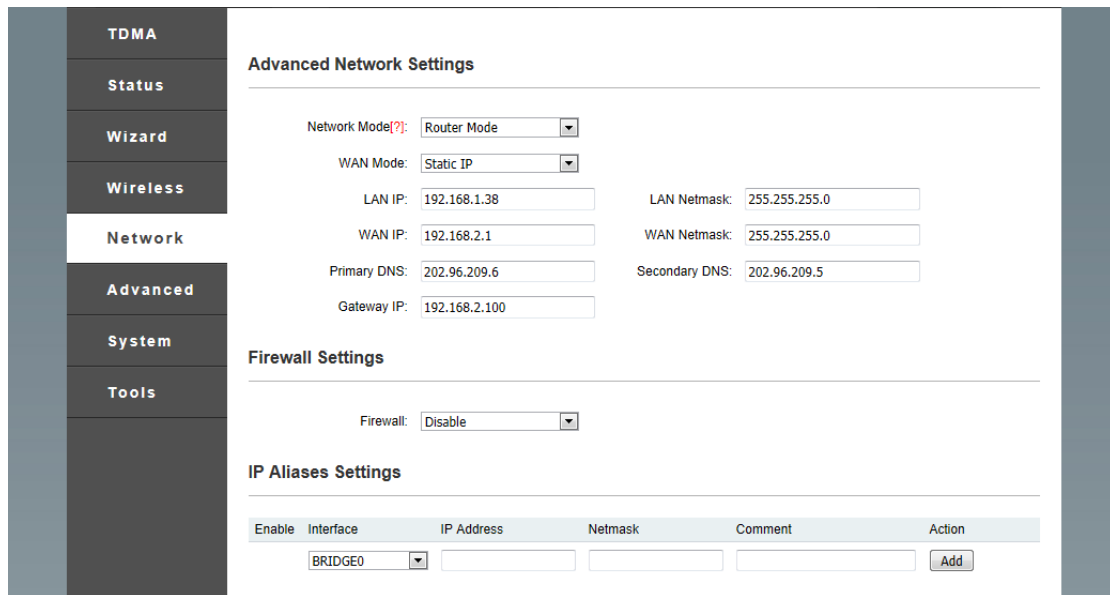

Figure 20

WAN Mode: Wan mode is about WAN port being set static IP address and DHCP. Users need to manually set IP, subnet mask and etc when it is set as static IP. The device will auto get IP address from DHCP server when it is set as DHCP.

WAN IP: IP address of WAN port, can be set the same IP address of the same segment which is to

connect to network.

WAN Subnet Mask: Subnet Mask of WAN port can be set the same address of the same segment which is to connect network.

Attention: IP address of WAN port can't be set the same as the existing IP on the network in order to avoid IP address conflict.

LAN IP: IP address of LAN port, users can set it according to his own demand. Make sure the IP address is not the same as other device IP address in the same network, so as not to cause IP address conflict.

LAN Subnet Mask: Subnet mask of LAN port, users can set the IP of LAN port according to his own demand.

Primary DNS and Second DNS: DNS server set the value of local DNS server.

Gateway: Generally it is ok to set gateway address as IP address of LAN port.

7.2 Bridge Mode

There is no WAN port for bridge mode. Both the LAN port on POE power supplier and the LAN2 port on DH-PFM88X are LAN ports, users can select one network port to connect according to his own demand. Refer to Figure 3 for more details. The setting of IP address of LAN port and subnet mask is same as route mode.

7.3 Firewall

When users want to use DH-PFM88X to shield some devices, they can use firewall to realize this function, see Figure 21 for more details; there are four situations of firewall filtering:

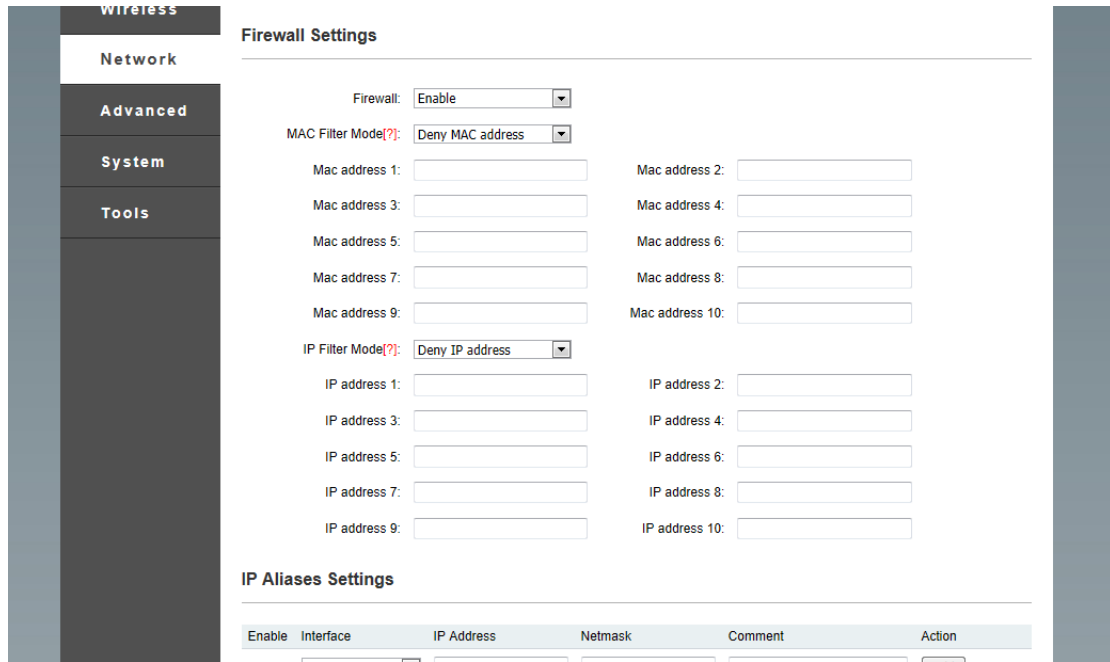

Figure 21

1. Filter a device with IP address xxx.xxx.xxx.xxx

After firewall is enabled, IP filtering mode is set as reject, and set any item among IP1~IP10 as the IP to be filtered.

2. Filter some device

After firewall is enabled, select MAC filtering mode as reject, set any item among Mac1~Mac10 as the MAC address of the device to be filtered.

3. Filter all other devices except the device with IP xxx.xxx.xxx.xxx

Select IP filter as accept, and set any item among IP1~IP10 as the IP to be accepted.

4. Only accept some device

After firewall is enabled, select MAC filtering mode as accept, set any item among Mac1~Mac10 as the MAC address of the device to be accepted.

8. Advanced Settings

See Figure 22 for more information about advanced settings page.

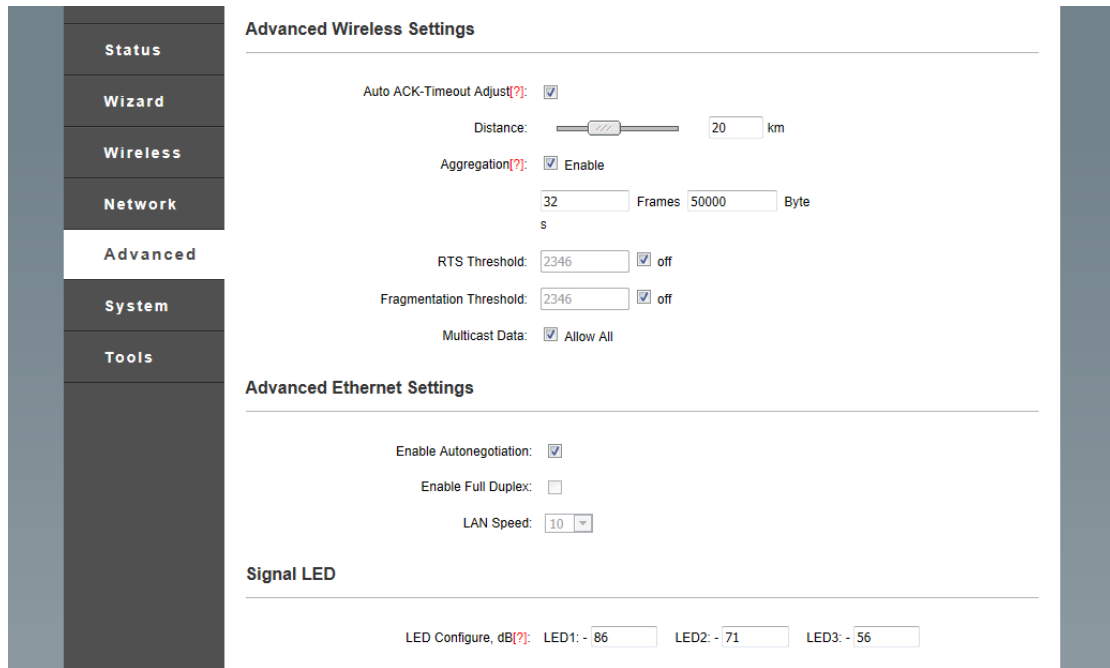

Figure 22

Auto ACK-Timeout Adjust: Users are recommended to open “ACK-Timeout auto adjustment”, which can auto test the distance between two devices; can set parameter according to this distance to optimize wireless connection quality.

Distance: The distance setting will be invalid if the “ACK-Timeout auto adjustment” is open. The system will auto test the device distance and optimize connection quality. Users need to close “ACK-Timeout Auto Adjustment” if they want to make the self-set distance valid.

Aggregation: Make different frames combine together and send out, enable this function to improve throughput rate and the device is enabled by default.

RTS Threshold: RTS/CTS mechanism will enable if the packet length is equal to or more than the set value. At this moment, the station will send a RTS to access point to inform it that data will be sent when the station tries to send data. After receiving the application, the access point will inform all the other stations in its covered area by CTS, asking them to delay sending. Meanwhile, the access point will

inform the station which sent request to send data.

Threshold Threshold: If the packet length surpasses the set value, it has to be divided into several data segment to send, and the number can only be even.

Multicast Data: When this function is enabled, DH-PFM88X will allow the multicast packet to pass it.

Antenna Switch: Set the value as external antenna when the device is using external antenna. Otherwise, it is built-in antenna.

Client Isolation: To enable this function can make the devices which connect to the same access point, WDS AP and WDS Repeater not be intercommunicated. It won't cause any influence to communication even if the client IP is repeated.

Max Client Limit: Limit the quantity of client which connect to access point, WDS AP and WDS Repeater and WDS client by setting it.

Enable Auto-Negotiation: When it is enabled, the LAN port will auto adjust its speed to max public level according to the connection speed and duplex mode of the device on the other end.

Enable Full Duplex: If the LAN port of DH-PFM88X allows the data transmission in two directions at the same time.

LAN Port Speed: For the LAN port speed of DH-PFM88X, there are only two kinds which are 10Mbps and 100Mbps.

Signal Intensity LED Setting: The setting of LED1, LED2 and LED3 here is the signal intensity value which is needed to light three LED lights. The signal intensity value of LED3 is the biggest (LED3>LED2>LED1), default settings are LED1:-86dB, LED2:-71dB and LED3:-56dB respectively. The LED1 will be on if the signal intensity is higher than LED1 but lower than LED2; both the LED1 and LED2 will be on when signal intensity is higher than LED2 but lower than LED3; All of the LED1, LED2 and LED3 will be on when the signal intensity is higher than LED3.

9. System Settings

There are four parts on the system setting interface which are configuration management, firmware configuration, device configuration and account information, see Figure 23 and 24 for more details.

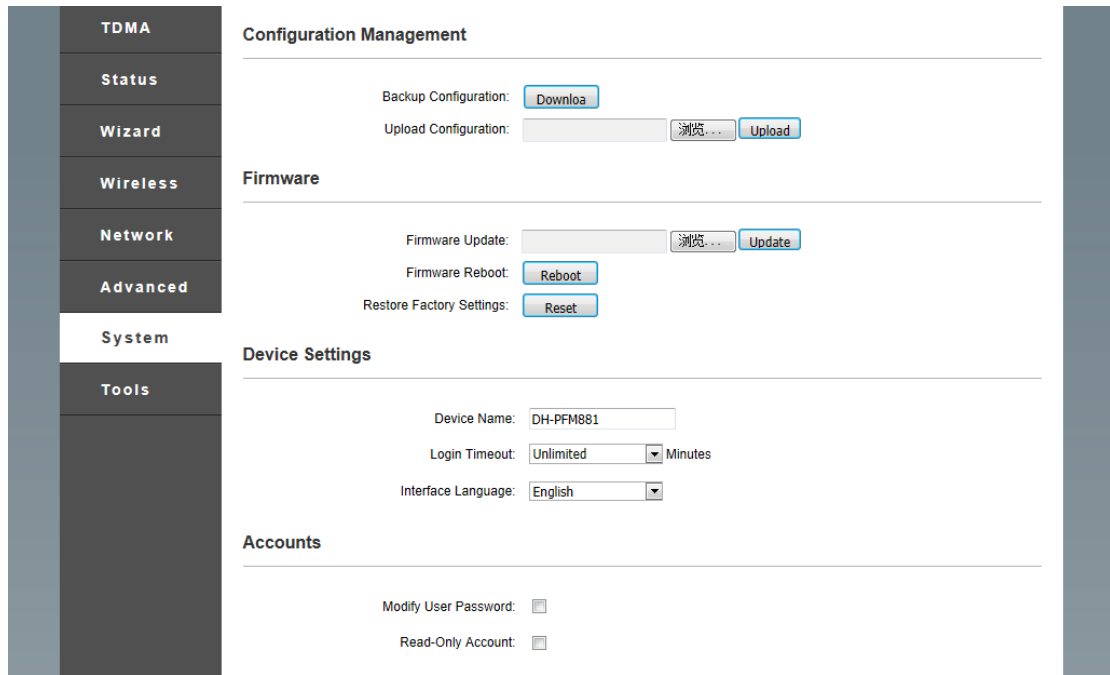

Figure 23

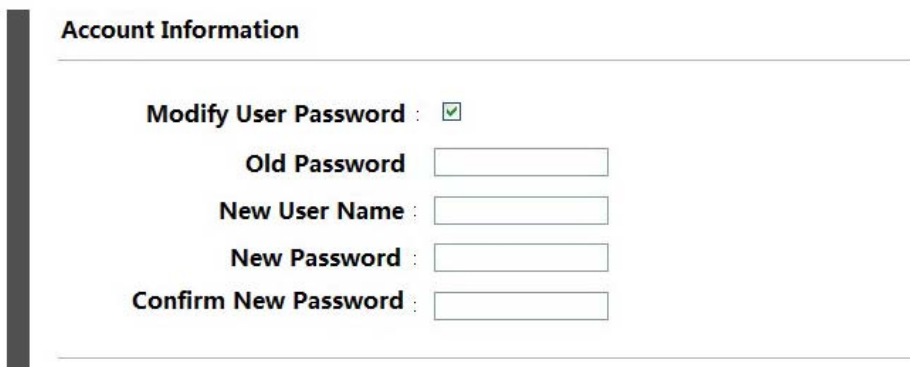

Figure 24

Back-up Configuration File: Click to download; backup the configuration on the current webpage,

pay attention that you can't modify the configuration file content manually.

Uploading Configuration File: Click to browse, select the previously-downloaded configuration file, click to upload, then you can restore the device configuration to it is when backuping configuration file.

Firmware Upgrade: Click to browse, select the version which is to be upgraded; click to upgrade, then the upgrade of device is on the way.

Firmware Reboot: Click reboot and the device begins to restart.

Restore Factory Settings: Click the factory setting on the webpage, then the device configuration will restore to factory settings after a period of time.

Device Name: User can set the device name according to his own demand.

Login Timeout: When the user login timeout is set to a value and there is no response after the webpage surpasses the time, it will auto jump to the login interface.

Interface Language: Users can set the language of the webpage according to his own demand.

Account Information: When user enables "modify user password", he can modify the account information according to his own demand.

10. Tools Application

There are two parts on the page of tools application which are testing tool and Telnet/DHCPD, as shown in Figure 25.

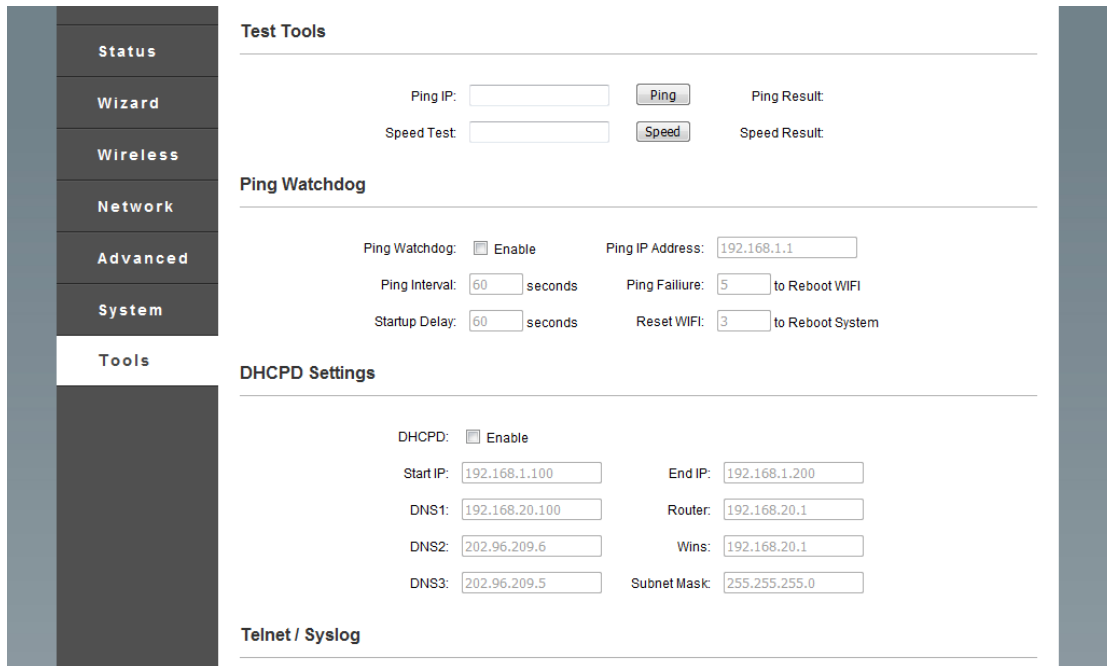

Figure 25

Ping IP: When user set a device IP in the ping IP bar, click ping, then ping's result is Alive if the device is connected to DH-PFM88X. Otherwise, it will be Not Alive.

Speed Test: When the access point is connected to client, set the IP address of access point (client) in the network speed detection of client (access point), then click speed detection, the result will display on the webpage after a while.

Ping Watchdog: It is used to continuously monitor the running condition of Wireless Bridge, especially use Ping tool when connecting to remote host. Wireless Bridge can ping target host for a long time, so if Wireless Bridge didn't receive the defined a certain number of replies, it means the tool will make the Wireless Bridge restart.

Ping IP Address: IP address of target host. **Ping interval:** time interval between two Pings.

Ping Failure: The device will restart WIFI when the times of continuous Ping failure reach the set value.

Start Delay: After the Wireless Bridge system started, the time set by delay will start to Ping target host.

WIFI Restart: The device will restart the system when the times of continuously restarting WIFI reaches the set value.

Telnet: When telnet is enabled, the command prompt window under Windows XP or Windows 7 adopts Telnet xxx.xxx.xxx.xxx (DH-PFM88X's IP) which can log in DH-PFM88X. It is unable to log in the device if Telnet is forbidden.

DHCPD: DH-PFM88X can be used a DHCP server when enabling DHCPD function, the DHCP client which is connected to it can obtain relevant address from it.

Start IP and End IP: The IP address obtained by address pool and DHCP client can be only set between start IP and end IP, which are usually set the same segment with DH-PFM88X.

Subnet Mask: Set subnet mask according to the IP of set address pool.

Router: It is the gateway address; user can set corresponding parameter according to what function he wants to realize.

WINS: Generally it is ok for user to set the same as route if there is no special requirement.

DNS1,DNS2,DNS3: User can set according to his demand; generally it is ok to set the address of local DNS server.

Syslog: Enable Syslog function, and at the same time set the IP of the PC where Syslog server is located, server port is set as 514, then you can see the relevant log information on the Syslog server.

NTP Client: PFM 88X can log on the Internet when NTP client function is enabled, and set the network address where NTP server is located, DH-PFM88X will auto calibrate the set time from NTP server and display it on the status display page.

SNMP Agency: SNMP agency allows network administrator to monitor network performance, search and solve network problems. Such as SNMP agency option enabled, fill in the name of a user in SNMP community, such as dahua, then fill in user's corresponding mailbox: leo@dahuatech.com, fill in creatcomm for location information, then save and apply. Install mrtg on the host, open mrtg webpage, then information like the flow which passes DH-PFM88X can be observed.

11. Common Networking Mode

11.1 Wireless Point-to-Point

We generally set one DH-DH-PFM881 as access point, and the other as client during point-to-point communication, see Figure 26 for more information.

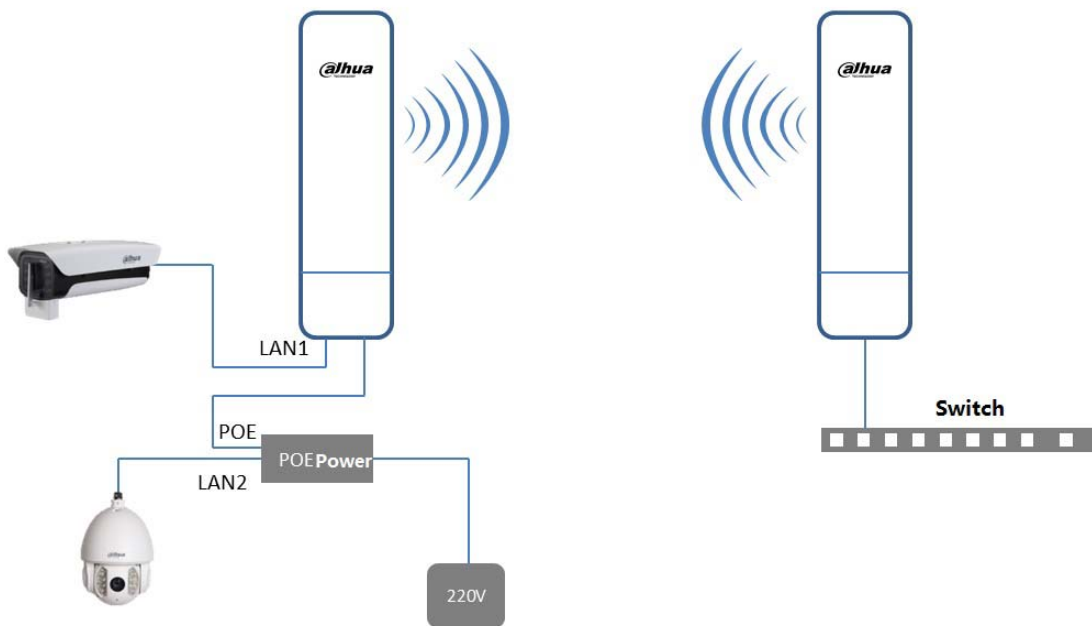

Figure 26

1. Two DH-PFM88X network setting page -> network mode are both set as bridge mode; firewall is forbidden for both DH-PFM88X and set different LAN IP;
2. Wireless page -> set wireless mode as access point and client respectively, both AP and client are set as the same SSID, set the same way of encryption and password for wireless encryption, like WPA->WPA2->CCMP->1234567890, output power is set as 9 dBm, AP frequency can be set as 5.785GHz, channel width of AP and client can be set as 20MHZ;
3. Attention: Relative direction needs to be adjusted for access point and client.

4. Use one computer to ping another one, which means inputting ping xxx.xxx.xxx.xxx (IP of another computer) in one computer;

Expected Result: After the connection between access point and client, the computer which connected access point and client can be interpinged, meanwhile, you can see the number of connections is one on the page of status display for access point.

11.2 Wireless Point-to-Multipoint

Generally we set DH-DH-PFM880 as access point (single AP covers 90° , combination of four pieces cover 360°), and other DH-DH-PFM881 are set client when it is during point-to-multipoint communication, see Figure 27 for more details.

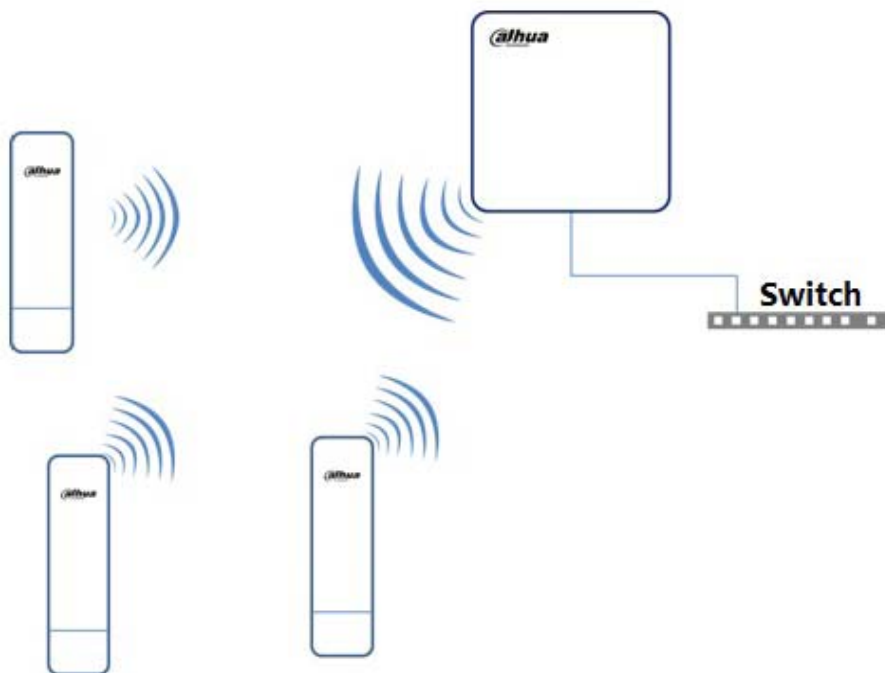

Figure 27

1. Network setting page of all the DH-PFM88X-> network mode are all set as bridge mode, and firewall is forbidden for all (default is closed), set different LAN IP:

2. Wireless page -> set wireless mode as access point and client respectively, both AP and client are set as the same SSID, set the same way of encryption and password for wireless encryption, like WPA->WPA2->CCMP->1234567890, it is recommended to finish configuration according to device wizard;
3. Attention: Relative direction needs to be adjusted for access point and client.
4. Use one computer to ping another one, which means inputting ping xxx.xxx.xxx.xxx (IP of another computer) in one computer;

Expected Result: After the connection between access point and client, the computer which connected access point and client can be interpinged, meanwhile, you can see the number of connections is N on the page of status display for access point. (N means the number of connected client)

11.3 Wireless Coverage Blind Angle Adjustment Mode

When the monitoring point is blocked seriously, we generally adopt two CPE back-to-back connection to adjust angle during the direct communication between client wireless and central AP, see Figure 28 for more information.

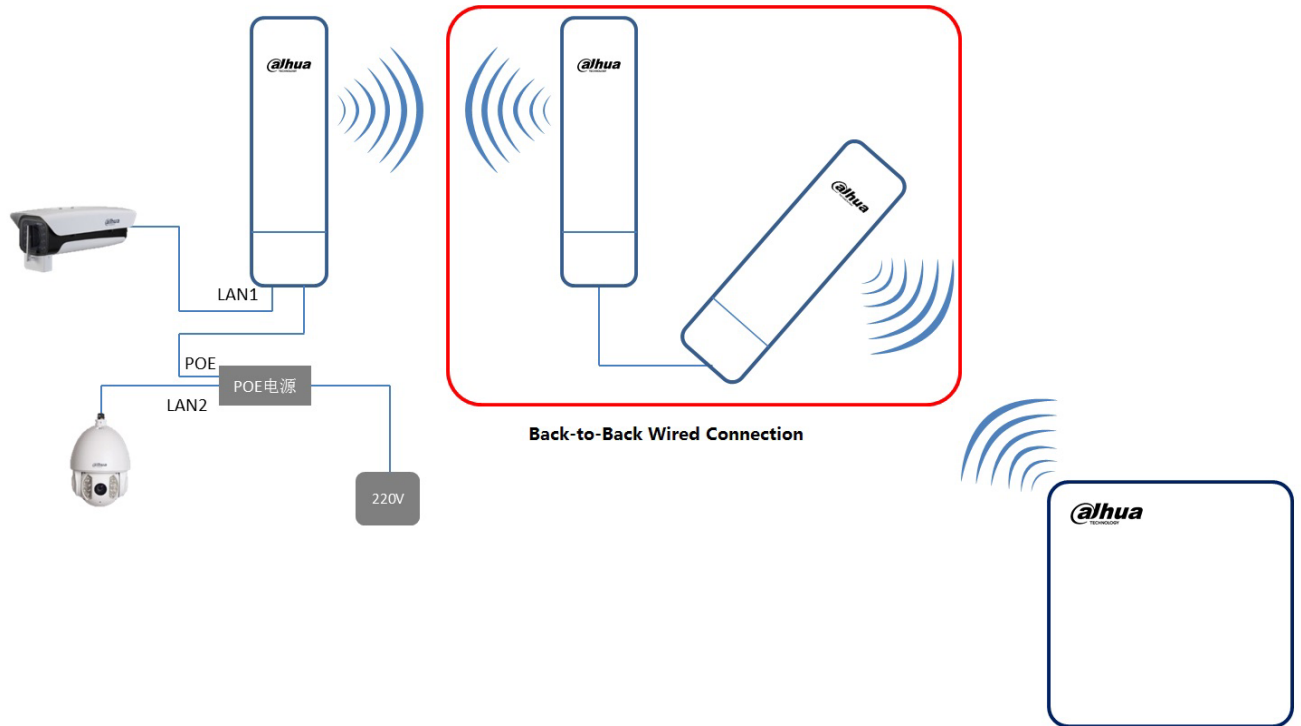

Figure 28

1. Wired connection for two bck-to-back devices
2. Downlinked client device is set as access point, uplinked central AP device is set as client
3. Refer to 11.1 and 11.2 for detailed configuration
4. Expected Result: After the connection between access point and client, the computer which connected access point and client can be interpinged, meanwhile, you can see the number of connections is N on the page of status display for access point. (N means the number of connected client)

11.4 Route Mode Networking

When TurboBridg5A is working under route mode, it is used as a router, see Figure 29 for more information, the POE port of POE power supplier connects DH-PFM88X, the LAN port of POE power supplier connects external network, the LAN port of DH-PFM88X connects computer, the exact configuration is shown as follows:

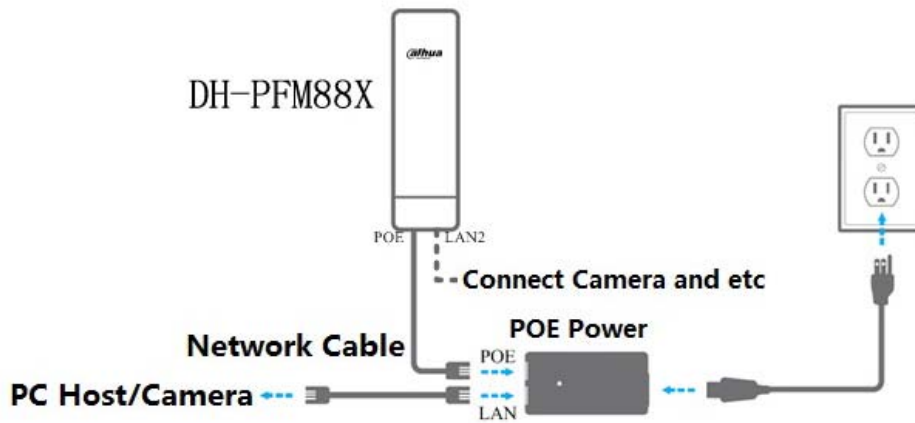

Figure 29

1. Network setting page -> network mode are both set as route mode, firewall is forbidden. Users can set WAN mode as DHCP or static IP according to the fact whether there is DHCP server on the main network, meanwhile, LAN IP users can modify the IP according to their demand, but they are recommended not to modify IP too often, just in case the IP is forgotten and it will bring a lot of trouble to your own life. When there is no DHCP in the external network to which DH-PFM88X is connected, then the users need to set relevant parameters manually. At this moment, WAN IP is set differently with the IP of other hosts from external network to which DH-PFM88X is connected, other parameters can be set the same as the host which connects to the main network. For example: WAN subnet mask, main DNS, auxiliary DNS, gateway can be set the same as other hosts which connect to external network, the way of setting LAN IP and LAN subnet mask should be the same as the way of setting DHCP.

Attention: LAN IP can't be set as the same segment with WAN IP

2. Wireless setting page->set wireless mode as access point, network name can be any name, users can set output power according to the distance between the devices, it is recommended to set the max if it is in outdoor environment. Users can set the frequency of AP according to the surrounding wireless environment setting, generally it can be set 5785MHz, wireless encryption is set not to be encrypted;
3. Enable DHCPD on the tool application page, please refer to the setting method of DHCPD in chapter

10 to set the parameters of DHCPD.

4. The network name of wireless connection is the WiFi network you set in advance, after the computer is connected to DH-PFM88X, the WAN port address of ping DH-PFM88X, for example, the WAN port IP of ping DH-PFM88X is 192.168.2.50, then you just input ping 192.168.2.50;

Expected result: The computer which is connected to the LAN port of TurboBridg2 can ping through the WAN port IP of DH-PFM88X.

Expected result: the computer which is connected to LAN port of TurboBridg2 can ping through WAN port IP of DH-PFM88X.

12. FAQ

1. The device can't boot up normally:

- (1). The network cable between CPE device and POE module is over 40m.
- (2). The quality of network cable didn't meet the standard of UTP-5 categories.
- (3) The crystal head of network cable is insecure or cable sequence error (remake the crystal head)

2. Forgot IP address and unable to restore factory default

Please press Reset button for 5-10 seconds, try to input 192.168.1.36 IP to log in the device after all the LED lights are on.

3. Why can't fine wireless access point in my computer?

Solution: wireless system is connected with max working rate, the exact rate depends on distance and

environment. Users can detect the following steps to make sure the max possible connection rate is obtained.

- (1) The location of wireless access point

Try to adjust the location and direction of wireless access point.

- (2) Wireless channel

The interference could be obviously improved if you use other communication channel;

- (3) Wireless interference

Other devices may also cause interference, so try to shut off other devices and check if the situation is improved. Users also can shield the devices which cause interference or adjust the position.

4. The signal intensity is too low.

- (1) It is not visible between CPE and AP due to bigger blocks.
- (2) The surface plate of CPE doesn't face AP directly; the vertical angle between AP and CPE is not suitable.
- (3) CPE is installed on the window, which may cause interference.
- (4) The distance between AP and CPE is too far.

5. Why is the signal intensity high but the throughput capacity low?

Reasons:

- (1) Too much interference or multipath interference.
- (2) Something is wrong with the device Ethernet port.

6. Frequent packet loss, serious packet loss with several devices in the same area, it will be better when communication channel is changed.

Same frequency interference will be caused if several DH-PFM88X are used in the same area without separate the channels of two devices. Users are recommended to separate the frequencies of them so as not to make the communication channels overlapped. It is recommended to make the frequency

difference between two devices over 20M if the width of communication channel is 20M.

7. Packet loss and big time delay for ping device address of the computer

- (1) Port isolation for AP which connects the same POE switch.
- (2) Bad pressing and connection for cable crystal head (remake crystal head)

8. Users often lose connection and the speed is low.

- (1) Too many users of AP access.
- (2) Weak AP signal.
- (3) Too many serious interference signals in the surrounding, client and AP are not binded.
- (4) Check user number and if the upper level network bandwidth is already full.

13. Construction attention for wireless bridge and monitoring.

13.1 Construction attention

1. The horizontal direction and vertical angle of antenna

Try to make the AP antenna on the base station slope down a certain angle because the antenna between base station and wireless bridge is directional. Meanwhile, try to make AP and client antenna aim each other horizontally.

2. Height for setting antenna

There are some certain requirements for the distance between two points and height for setting antenna during the actual wireless communication between two points due to the fact that the earth is a sphere.

Please refer to the following sheet for more details.

Frequency	3Km	5Km	10Km	15Km
5.8GHz	5m	7m	11m	16m

3. Geographical environment

Place for the farthest distance of communication is sea level and clear flat land, which is the generally-used geographical condition to evaluate the communication distance of wireless communication devices. The second farthest are places like rural area, hill, riverbed and other half obstacle, half open environment. The shortest communication distance is place like city building complex or among mountains. In a word, the more intensive the obstacles are, the more influence it will cause to wireless communication distance, especially to metal objects. Therefore, make sure the client and access point are directly visible during the actual construction;

4. Electromagnetic environment

Direct current dynamo, grid system, switching power, electric welding machine, high frequency electronics, computer, single chip and other devices all can cause different levels of influence to communication distance of communication devices.

5. Climatic condition

The communication distance will be longer if the air is dry; the communication distance will be shorter if the air is wet (especially rainy, snowy weather)

6. Try to avoid same frequency and adjacent frequency interference

Users need to search what frequencies that other devices are using first when setting the frequency of access point, which has to avoid these frequencies as far as possible. Meanwhile, the access point frequency has to be separated a certain distance from the surrounding frequencies which are being used in order to prevent adjacent frequency interference. For example, when communication channel width is 20M, so it has to be separated over 20M from the frequency being used. Meanwhile, the frequency between each AP should be set like this.

13.2 Test Situation

Testing distance: 3.5 km

Test environment: The test place is located between Beicai Town and Zhangjiang Town in Pudong New

District City of Shanghai, and one site is located on the 12th floor in a community while the other site is located on the 5th floor in an office building, which can basically be directly visible without any obvious blocks.

Test result:

Frequency	Signal Intensity	Channel Width	Throughput Rate
5825MHz	-72dBm approx	20M	30-35Mbps

13.3 Reference Setting:

Set the network name according to your demand;

Country code: America;

Frequency: 5725MHz~5850MHz;

Set max output power, which can only be 9 dBm in Chinese national code; and max output power can be 9 dBm when country code is American and test mode;

Enable TDMA, which can effectively improve overall performance during point-to-multipoint transmission;

Set channel width according to actual bandwidth demand, generally it is higher than 20M when is it 40M;

The IP address between access point and client is different; make sure there are no devices with same IP address in the LAN;

Keep other configuration as default;



Dahua Technology Co., Ltd

Address: No.1199 Bin'an Road, Binjiang District, Hangzhou, PRC.

Postcode: 310053

Tel: +86-571-87688883

Fax: +86-571-87688815

Email: overseas@dahuatech.com

Website: www.dahuatech.com