

User Guide

PANTUM

WWW.PANTUM.COM

Pantum M6550 Series Monochrome Laser MFP



It is recommended to carefully read this Guide before using the printer

Preface

Welcome to the Pantum series products!

We heartily appreciate your using of Pantum series products!

To protect your vital interests, please carefully read the following statements.

Legal Notice

Trademark

Pantum and Pantum logos are registered trademarks of Zhuhai Seine Technology Co., Ltd.

Microsoft®, Windows®, Windows Server® and Windows Vista® are trademarks registered by Microsoft Corporation in the United States or other countries/regions.

The ownership to the names of the software in this User Guide belongs to their respective companies in accordance with corresponding license agreement, and they are referred for instructions only.

All other product and brand names herein may be the registered trademarks, trademarks or service marks of their respective owners, and they are referred for instructions only.

Copyright

The copyright of this User Guide is owned by Zhuhai Seine Technology Co., Ltd.

It is prohibited to copy, translate, modify and transmit this User Guide by any means or in any form without the prior written consent of Zhuhai Seine Technology Co., Ltd.

Version: V1.0

Disclaimer

For a better user experience, Zhuhai Seine Technology Co., Ltd. reserves the right to make changes to the User Guide. The information contained herein is subject to change without notice.

Users are responsible for any damages arising from failing to follow this User Guide. Meanwhile, except the express warranty made in the product maintenance manual or service commitment, Zhuhai Seine Technology Co., Ltd. does not make any express or implied warranty or guarantee to this User Guide (including composing or words).

Using this product to copy, print, scan certain documents or images or make other forms of operations may be prohibited by the local laws. If you are uncertain about the legality of using this product for certain documents or images, you should consult your legal advisor in advance.

The product can only be used safely in the non-tropical areas at an altitude no higher than 2000 meters.

Safety Precautions

Laser Safety

The laser radiation is harmful to the human body. Since laser components are completely sealed in the printer, laser radiation will not leak. To avoid laser radiation, please do not randomly disassemble the printer!

The printer follows the provisions of Class 1 laser products under CFR standard. The printer has a Class III b laser diode, which has no laser radiation leakage among laser components. The following label is attached to the laser components inside the printer:







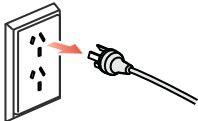

Reclamation and recycling

To protect the environment, our corporation has already established the system of reclamation and recycling for waste products. Please refer to the Pantum official website for product recovery at www.pantum.com.

Safety Warning

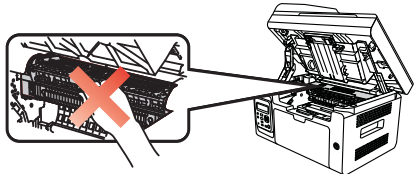
Please note the following safety warnings before using the printer:

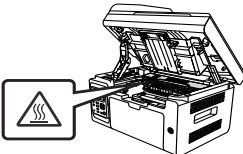
! Warning	
 <p>There is high-voltage electrode inside the printer. Before cleaning the printer, make sure the power is turned off!</p>	
 <p>Plugging and unplugging the power cord plug with a wet hand can result in an electric shock.</p>	
 <p>The fuser unit is hot when and after printing. Touching the fuser unit (the shaded area as shown) may cause burns!</p>	
 <p>The fuser unit is attached with a high temperature warning label. Please do not remove or damage this label.</p>	

Precautions

Precautions before Using the Printer:

1. Read and understand all instructions;
2. Familiarize yourself with the basic principles associated with operating electrical appliances;
3. Comply with all warnings and instructions marked on the equipment or specified in the manual supplied with the equipment;
4. If the operating instructions conflict with the safety information, please refer back to the safety information, as you may have misunderstood the operating instructions. If you cannot resolve the conflicts, please call the Customer Service Hotline or contact a service representative for help;
5. Before cleaning the equipment, remove the power cord from the AC power supply outlet. Do not use liquid or aerosol cleaners;
6. Please make sure that the equipment is put on a stable desktop surface to avoid serious damage caused by the falling of the equipment;
7. Do not put the equipment near a radiator, an air conditioner, or a ventilation pipe;
8. Do not place any articles on top of the power cord. Do not put the equipment in a place where its power cord will be stepped on by people;
9. Outlets and extension cords must not be overloaded. This may reduce performance and could result in fire or electric shock;
10. Do not allow pets to chew on the AC power cord or the computer interface cable;
11. Do not allow sharp objects piercing equipment slot, so as to avoid contact with the high-voltage device, which otherwise may result in fire or electric shock. Take care not to spill liquids onto the equipment;
12. Do not disassemble the equipment so as to avoid the risk of electric shock. Necessary repairs may only be carried out by professional maintenance personnel. Opening or removing the cover could result in an electric shock or other potential hazards. Incorrect disassembly and assembly could also result in an electric shock during future use;
13. If any one of the following occurs, disconnect the equipment from the computer and pull out the power cord from the AC wall socket and contact a qualified member of the service personnel for maintenance:
 - Liquid has been spilled into the equipment.
 - The equipment has been exposed to rain or water.
 - The equipment falls, or the cover is damaged.
 - Significant changes in the equipment's performance.
14. Only adjust the control mentioned in the instructions. Incorrect adjustment of other controls may result in damage and mean that professional maintenance personnel need to spend more time fixing it;
15. Do not use the equipment in a thunderstorm so as to avoid the risk of an electric shock. If possible, pull out the AC power cord during a thunderstorm;
16. If you continuously print multiple pages, the surface of the tray will become very hot. Take care not to touch this surface, and keep children away from this surface;
17. The signal wire of the device connected with the printer can not be connected to the outdoors;
18. Please ensure timely ventilation in case of a prolonged use or printing huge amounts of documents in a poorly ventilated room;
19. In standby status, the product will automatically enter into the power saving (sleep) mode if it does not receive any job order for a while (such as 1 minute); and it can realize zero power consumption only if it has not been connected with any external input power supply;
20. As the Class 1 equipment, the product must be connected to the power supply outlet with protective grounding line when using;
21. This product should be placed according to the shipping marks on the product package box during delivery;
22. This product is a kind of low-voltage equipment. When using this product below the specified voltage range, please refer to the product precautions or call Pantum Aftersales Service Centre, if the toner comes off the printed contents, or the equipment starts slowly;
23. This product is sold as a complete machine. The consumers can go to Pantum Aftersales Service Centre to purchase parts they need. If the product sold is inconsistent with the package list, please go to the specified Aftersales Service Centre to solve the problem;
24. Install this product in a place with the temperature between 5°C to 35°C, and the relative humidity between 20% to 80%;
25. For security and other reasons the printer may switch to intermittent printing after a certain amount of continuous printing.

-
26. This device complies with Industry Canada licence-exempt RSS standard(s). Operation is subject to the following two conditions:
 - (1) this device may not cause interference, and
 - (2) this device must accept any interference, including interference that may cause undesired operation of the device.
 27. Radiation Exposure Statement:

This equipment complies with Canada and FCC radiation exposure limits set forth for uncontrolled environments. This equipment should be installed and operated with a minimum distance of 20cm between the radiator and your body.

This transmitter must not be co-located or operating in conjunction with any other antenna or transmitter.
 28. This equipment has been tested and found to comply with the limits for a Class B digital device, pursuant to Part 15 of the FCC Rules. These limits are designed to provide reasonable protection against harmful interference in a residential installation. This equipment generates, uses and can radiate radio frequency energy and, if not installed and used in accordance with the instructions, may cause harmful interference to radio communications. However, there is no guarantee that interference will not occur in a particular installation.
- If this equipment does cause harmful interference to radio or television reception, which can be determined by turning the equipment off and on, the user is encouraged to try to correct the interference by one or more of the following measures:
- Reorient or relocate the receiving antenna.
 - Increase the separation between the equipment and receiver.
 - Connect the equipment into an outlet on a circuit different from that to which the receiver is connected.
 - Consult the dealer or an experienced radio/TV technician for help.
29. Changes or modification not expressly approved by the party responsible for compliance could void the user's authority to operate the equipment.
 30. The power consumption of the product is 3.137W in networked standby if all wired network ports are connected and all wireless network ports are activated;
 31. Shielded cables must be used with this unit to ensure compliance with the Class B FCC limits.
 32. Please keep this User Guide properly.

Legal Information



This symbol indicates that, at the end of your product's life, it must not be discarded as domestic waste. Instead, you should dispose of your used equipment at a designated collection point for the recycling of waste electrical and electronic equipment. Ref: EU Directive 2002/96/EC on Waste Electrical and Electronic Equipment (WEEE). Please contact your distributor / supplier for further information.



This product is suitable for indoor use only.



European Community (EC) directives conformity

This product complies with the protection requirements of EC directives 2004/108/EC and 2006/95/EC on the approximation and harmonization of the laws of the Member States relating to electromagnetic compatibility and safety of electrical equipment designed for use within certain voltage limits.

The manufacturer of this product is: Zhuhai Seine Technology Co., Ltd., No. 3883, Zhuhai Avenue, Xiangzhou District, Zhuhai City, Guangdong, P.R. China.

A declaration of conformity to the requirements of the Directives is available upon request from the Authorized Representative.

This product satisfies the Class B limits of EN 55022 and safety requirements of EN 60950.



This printer is fully compliant with the ROHS Directive 2009/95/EC and the requirements of the revised Directive 2011/65/EU for managing toxic and hazardous substances.

Table of Contents

1. Before Using the Printer	1-2
1.1. Introduction of Models	1-2
1.2. Supplied Accessories.....	1-3
1.3. Product View.....	1-4
1.4. Laser Toner Cartridge	1-5
1.5. Control Panel	1-6
2. Paper and Print Media.....	2-2
2.1. Paper Specification.....	2-2
2.2. Special Paper	2-3
2.3. Non-printing Area and Non-scanning Area	2-4
2.4. Load the Paper	2-5
2.5. Paper and Manuscript Use Process	2-6
3. Installation and Uninstallation of the Driver Software	3-2
3.1. Windows-based Driver.....	3-2
3.1.1. Introduction	3-2
3.1.2. Installation Steps.....	3-2
3.1.3. Uninstallation	3-10
3.2. Mac-based Driver	3-12
4. Wired Network Settings (For printer models that support wired network printing)	4-2
4.1. Install the Printer to Network.....	4-2
4.2. Control the Network Printer	4-2
4.2.1. View or Change Network Settings	4-2
4.2.2. Set or Change Web Server Login Password	4-2
5. Wireless Network settings (for models with Wi-Fi printing)	5-2
5.1. Configuration via Button	5-2
5.2. Configuration via USB Connection	5-2
5.2.1. Wi-Fi Configuration Tool.....	5-2
5.3. Wi-Fi Hotspot Configuration.....	5-5
5.4. Turn off Wireless Device.....	5-5
6. Pantum Mobile Print and Mobile Scan	6-2
6.1. Introduction to Pantum Mobile Print and Mobile Scan.....	6-2
6.1.1. What's Pantum Mobile Print and Mobile Scan?	6-2
6.1.2. Download Pantum Mobile Print and Mobile Scan.....	6-2
6.1.3. Supported Mobile Operating System	6-2
6.2. Operation Steps for Mobile Print.....	6-2
6.2.1. For Android Devices.....	6-2
6.2.2. For Apple IOS Devices (iPad, iPhone, etc).....	6-4
6.3. Operation Steps for Mobile Scan.....	6-6
6.3.1. For Android Devices.....	6-6
6.3.2. For Apple IOS Devices (iPad, iPhone, etc).....	6-9
7. General Settings.....	7-2
7.1. System Settings.....	7-2
7.1.1. Toner Save Setting.....	7-2
7.1.2. Language Setting	7-4
7.1.3. Restore to Factory Settings	7-4
7.1.4. Sleep Time Setting.....	7-5
7.1.5. Network Settings.....	7-5
7.1.6. Network Information.....	7-6

8. Print	8-2
8.1. Print Function	8-2
8.2. Open Help Document	8-3
8.3. Duplex Print	8-4
8.4. Cancel Print Job	8-7
8.5. Mac System Print	8-7
9. Copy	9-2
9.1. Plain Copy	9-2
9.2. Bill Copy	9-3
9.3. ID Card Copy	9-3
9.4. Cancel Copy Operation	9-5
10. Scan	10-2
10.1. Push Scan	10-2
10.1.1. Single Page Scan	10-2
10.1.2. Merge Scan	10-3
10.1.3. Other Scan Functions	10-4
10.2. Pull Scan	10-8
10.2.1. Pantum Scan Application	10-8
10.2.2. TWAIN Scan Driver	10-9
10.2.3. WIA Scan Driver	10-11
10.2.4. Cancel Scan Job	10-14
10.3. Mac System Scan	10-15
10.3.1. ICA Scan	10-15
10.3.2. TWAIN Scan	10-18
11. Routine Maintenance	11-2
11.1. Cleaning the Printer	11-2
11.2. Maintenance of Laser Toner Cartridge	11-5
11.2.1. Use and Maintenance of Laser Toner Cartridge	11-5
11.2.2. Service Life of the Laser Toner Cartridge	11-5
11.2.3. Replace Laser Toner Cartridge	11-5
12. Troubleshooting	12-2
12.1. Clearing Jammed Paper	12-2
12.2. Error Message	12-5
12.3. Common Troubleshooting	12-6
12.3.1. Common Trouble	12-6
12.3.2. Image Defects	12-8
13. Menu Structure	13-2
13.1. Copy Settings	13-2
13.2. Scan Settings	13-4
13.3. System Settings	13-5
13.4. Information Report	13-7
13.5. Version Information	13-7
14. Product Specifications	14-2

Before Using the Printer

1

Chapter

1. Before Using the Printer	2
1.1. Introduction of Models	2
1.2. Supplied Accessories.....	3
1.3. Product View.....	4
1.4. Laser Toner Cartridge.....	5
1.5. Control Panel.....	6



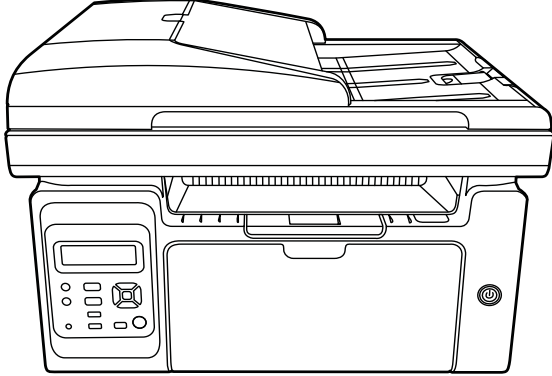

1. Before Using the Printer

1.1. Introduction of Models

This product have the following configurations:

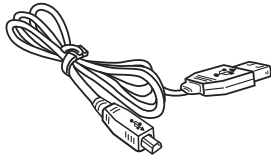
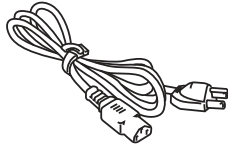
Series Name	M6550 Series
Picture	
Basic Function	Print, Copy, Scan
Basic Models	US Model, T Model, Wi-Fi Model
Basic Specifications	<ul style="list-style-type: none">• The maximum print speed of A4 paper is 22ppm, and that of letter paper is 23ppm.• The maximum volume of feeder tray is 150 pages and the maximum volume of output tray is 100 pages• The maximum print volume is 20000 pages per month• Support full-color scanning• Support the function of scanning to email

1.2. Supplied Accessories

Name	
USB Interface Cable	 A coiled white USB interface cable with a standard USB-A connector on one end and a smaller connector on the other.
Power Cord	 A coiled white power cord with a three-pronged AC power plug on one end and a two-pronged power plug on the other.
CD-ROM	 A CD-ROM disc with the PANTUM logo and 'User Printer' text on its surface.
Quick Setup Guide	 A small, folded booklet or guide with the PANTUM logo and 'Quick Setup Guide' text on its cover.
Pantum Warranty	 A vertical rectangular warranty card with the PANTUM logo at the top and a small rectangular area at the bottom.



Note: • The Pantum Warranty may not be attached in some regions.

Product ie

Side view (1)

o. Series

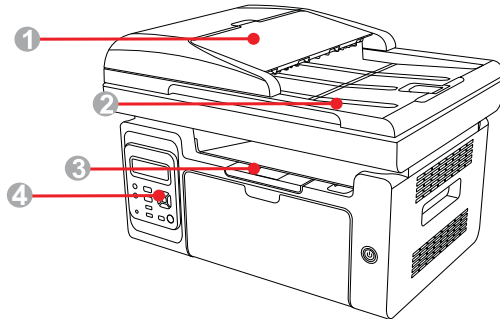

1 Cover

Output Bin

Control Panel

Side view ()

o. Series

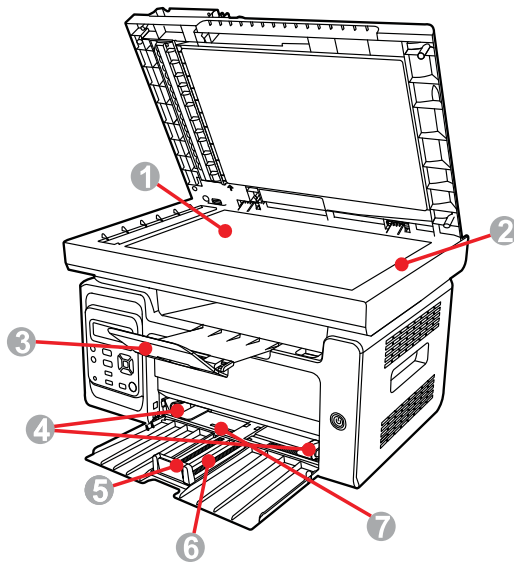

1 Glass Platen

Scanning Platform

Output Tray

Automatic Feed Paper Deflector

Paper Stop

Feeder Tray

Automatic Feeder Tray

Rear view

Model Series

Diagram

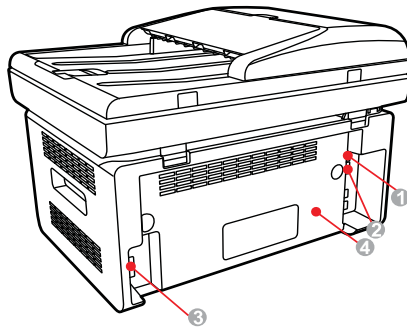

-
- | | |
|---|-------------------|
| 1 | SB Interface |
| | Network Interface |
| | Power Interface |
| | Rear Cover |
-



Note: • The sketch map may vary slightly with different models and functions.

Laser Toner Cartridge

| Service Life of the Laser Toner Cartridge

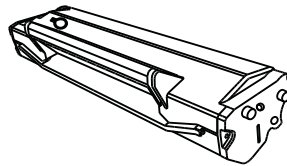

Type	Average Print Volume
Laser Toner Cartridge with Standard Capacity	About 1000 Pages (The above data is based on ISO/IEC 19752 standard)



- Note:** • The model is subject to increase without notice.
- Consumables capacity may vary with different using types.
 - It's not recommend using consumables other than the original Pantum consumables.
 - Any damages caused by using non-Pantum original consumables are not covered by the Warranty.
-

1.5. Control Panel

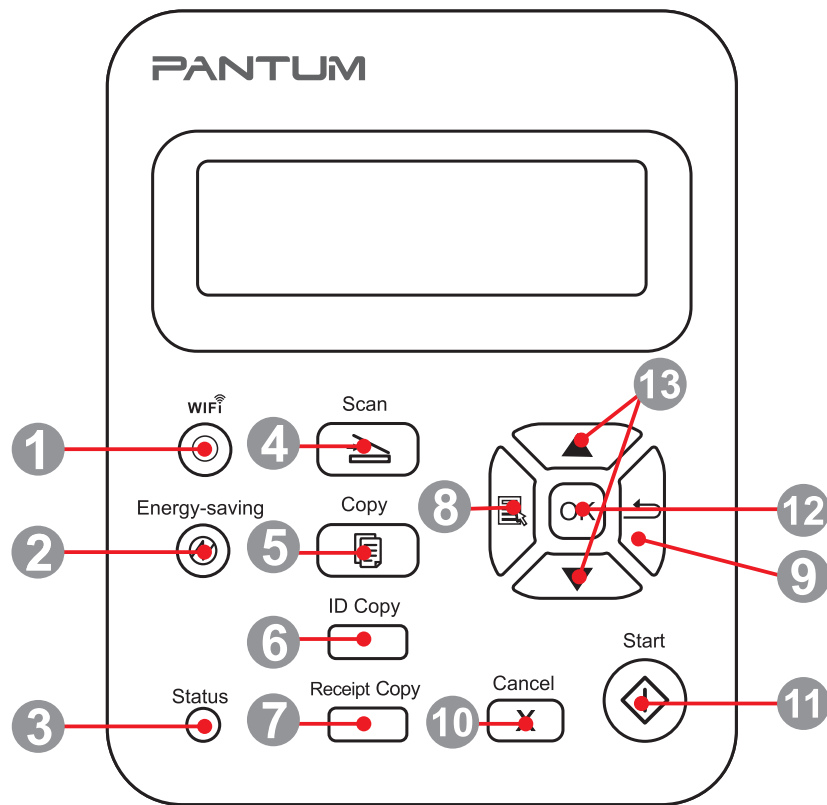

1	Wi-Fi button	This button indicates the Wi-Fi connection status (only applicable to Wi-Fi Model).For Non-Wi-Fi Model,this button is for toner saving.
2	Power Saving/ Wake-up Button	Press this button to switch to power saving status or wake the machine from power saving status
3	Status Light	This light indicates the ready, alarm and other status of the printer Green light: Normal Orange light: Alarm or Error in toner cartridge Red Light: Error
4	Scan Button	Press this button to enter into scan mode
5	Copy Button	Press this button to enter into copy mode
6	ID Card Copy Button	Press this button to enter into ID Card Copy mode
7	Bill Copy Button	Press this button to enter into Bill Copy mode
8	Menu Button	Press this button to access the menu options to make the settings
9	Back Button	Press this button to go back to the upper-level page
10	Cancel Button	Press this button to cancel the operation
11	Start Button	Press this button to start the corresponding operation after the operation setting
12	OK Button	Press this button to save the setting
13	“▲” and “▼”	Press these two buttons to browse each menu and its options

Paper and Print Media

2

Chapter

2. Paper and Print Media.....	2
2.1. Paper Specification.....	2
2.2. Special Paper	3
2.3. Non-printing Area and Non-scanning Area	4
2.4. Load the Paper	5
2.5. Paper and Manuscript Use Process	6

2. Paper and Print Media

2.1. Paper Specification

M6550 Series	Media Type	Plain paper, thick paper, transparent film, carton paper, label paper, envelope, thin paper
	Media size	A4, A5, A6, JIS B5, ISO B5, B6, Letter, Legal, Executive, Statement, Monarch envelope, DL envelope, C5 envelope, C6 envelope, NO.10 envelope, Japanese Postcard, Folio, Oficio, Big 16k, 32k, 16k, Big 32k, ZL, Yougata4, Postcard, Younaga3, Nagagata3, Yougata2, Custom
	Media weight	60~163g/m ²
	Feeder tray volume	150 pages
	Output tray volume	100 pages



- Note:**
- It is recommended to use the standard paper and recycled paper for the printer.
 - It is not recommended to use special paper extensively, which may affect the service life of the printer.
 - The print media that does not meet the guidelines listed in this User Guide may result in poor print quality, increased paper jam and excessive wear of the printer.
 - Properties such as weight, composition, texture and humidity are important factors affecting the printer performance and output quality.
 - Please note the following matters when selecting the print media:
 1. Desired print effect: The print media selected should meet the requirement of the print tasks.
 2. Surface smoothness: The smoothness of the print media may affect the sharpness of the print outcome.
 3. Some print media may meet all the use guidelines contained herein, but they still can not bring satisfactory effect. This may be due to incorrect operation, inappropriate temperature and humidity, or other factors beyond the control of Pantum. Before purchasing large quantities of print media, make sure that the print media meets the specifications specified in this User Guide.
 4. Using print media that does not meet these specifications may cause damage to the printer.

2.2. Special Paper

This printer supports using the special paper for printing. Special paper includes: label paper, envelope, transparent film, thick paper, thin paper, etc.



- Note:**
- When using special paper or print media, be sure to select matched print type and size in the print settings so as to get the best print effect.
 - When using special media to print, it is recommended to load one piece of paper at one time.

| Please observe the following standards:

Types of Print Media	Correct Practices	Incorrect Practices
Label Paper	Use labels with no exposed lining paper only. Labels shall be put flat when using. Use labels of full sheet only. There is no guarantee that all the labels in the market can meet corresponding requirements.	Use wrinkled, blistered or damaged label papers.
Envelope	Envelopes should be loaded evenly.	Use wrinkled, nicked, stuck or damaged envelopes. Use envelopes with clips, snaps, windows, or coated linings. Use envelopes with self-adhesive stickers or other synthetic materials.
Transparent Film	Only use transparent films approved for use in laser printers.	Use transparent print media that is not suitable for laser printers.
Thick Paper	Only use heavy paper that is approved for use in laser printers and meets the weight specifications of this printer.	Use the paper whose weight is more than the specification of the media recommended for this printer, unless the paper is approved for use in this printer.

2.3. Non-printing Area and Non-scanning Area

The shaded part indicates the non-printing area and non-scanning area.

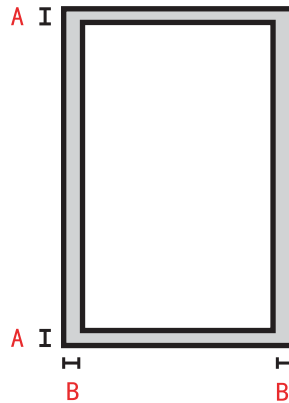

Usage	Paper Size	Top and Bottom Margins (A)	Left and Right Margins (B)
Print	A4	5 mm (0.197 inch)	5 mm (0.197 inch)
	Letter	5 mm (0.197 inch)	5 mm (0.197 inch)
Copy	A4	5 mm (0.197 inch)	5 mm (0.197 inch)
	Letter	5 mm (0.197 inch)	5 mm (0.197 inch)
Scan	A4	5 mm (0.197 inch)	5 mm (0.197 inch)
	Letter	5 mm (0.197 inch)	5 mm (0.197 inch)

Load the Paper

Steps are as follows:

- a) Open the feeder tray.

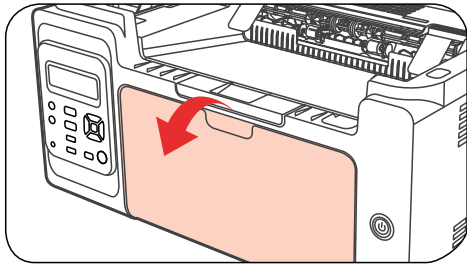

- b) Slide the automatic feed guides to match both sides of the paper.

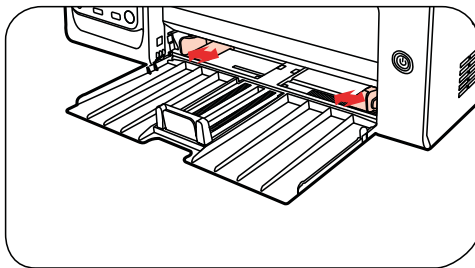

- c) Raise the output tray to avoid the paper from slipping and falling.

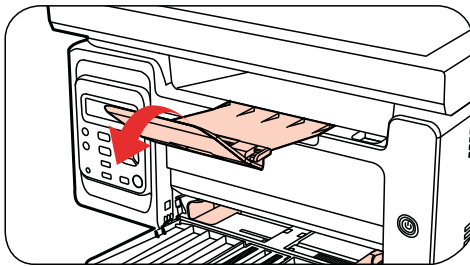

- d) Load the paper into the automatic feeder tray with the print-side up.

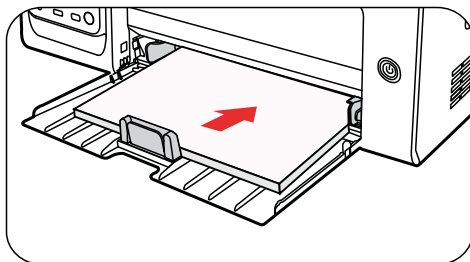

- e) Adjust the paper stop to match the paper size.

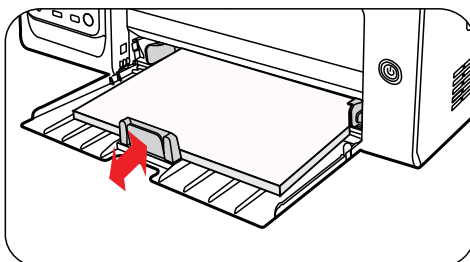



- Note:**
- If the paper loaded into the automatic feeder tray at one time exceeds 150 pages, paper will jam or cannot be fed in.
 - When using the printed paper, please make the side to be printed (the blank side) up.
 - When printing on A5 paper, it is recommended that the paper is fed in landscape orientation, which can extend the service life of the laser toner cartridge.

Warning



After printing, please immediately remove the paper, envelopes or transparent film paper. Stacking paper or envelopes may cause a paper jam or the paper curling.

Pa er and Manuscript se Process

manuscript requirements:

Type	Size
Plain paper, thick paper, transparent film, carton paper, label paper, envelope, thin paper	A4, A5, B5, Letter, Custom

Steps of use:

1). Raise the cover.

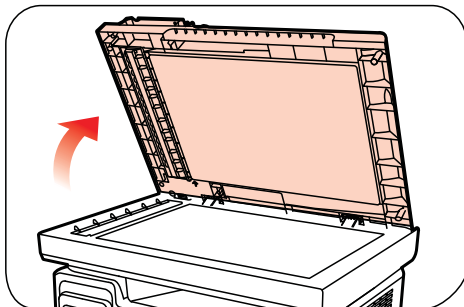

2). Load the manuscript face down.

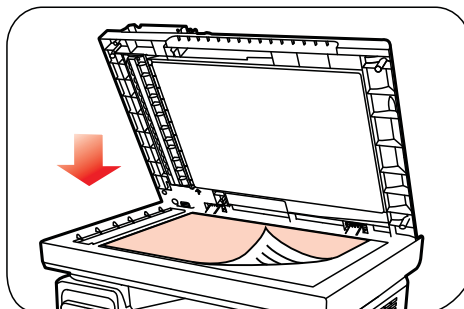

). Align the manuscript to match the appropriate paper size.

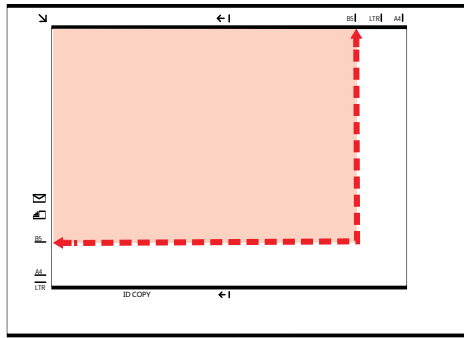

note: • If the manuscript does not match with any size marker, please align the upper-left corner of the manuscript with the arrow.

). Gently put down the cover.

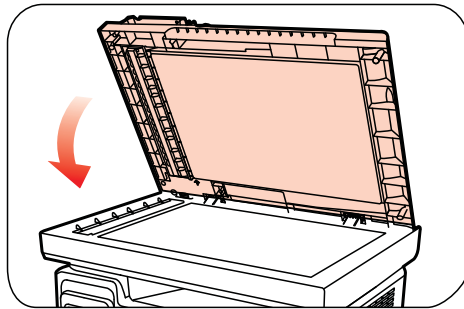

note: • Please put the paper or document on the scanner glass after the glue, ink or correction fluid are completely dried.

- Paper or manuscript with rough texture, concave and convex, oil stain and good smoothness has poor printing performance.
- Please make sure that there is no dust, fluff, etc. on the paper.
- Paper shall be put on a flat surface and stored under a cool and dry environment.

Installation and Uninstallation of the Driver Software

3

Chapter

3. Installation and Uninstallation of the Driver Software	2
3.1. Windows-based Driver.....	2
3.1.1. Introduction	2
3.1.2. Installation Steps.....	2
3.1.3. Uninstallation	10
3.2. Mac-based Driver	12

3. Installation and Uninstallation of the Driver Software

3.1. Windows-based Driver

3.1.1. Introduction

Driver software helps users to run the installer and uninstaller through the installation and uninstallation wizards, which provides the following modules and main functions:

- Autorun completes the automatic running of the installation CD.
- Installation: Provides users with the installation wizard of the printer driver.
- Uninstallation: Provides users with the uninstallation wizard of the printer driver.



Note: • For users of Windows XP and Windows Server 2003, when connecting the printer device for the first time, New Hardware Wizard Found window will pop up. You should close this window. If this window is not closed, the printer may not be detected, resulting in failure of installation.

3.1.2. Installation Steps

3.1.2.1 USB Model Installation (One Click Installation)

1) Running Interface

After inserting the installation CD, the Pantum interface will pop up and the installation CD will run automatically. See the figure below:



User authentication will be performed before the program runs. If the user is an administrator, this interface will be displayed. If the user is not an administrator, the prompt of "Insufficient privileges. Please install the printer with administrator privileges" will pop up.

) language Interface

After the running interface ends, if the printer is connected to the computer through USB cord, then the language interface pops up. Users select the language depending on different needs.



Note: • you can click to see the user guide and the content of the License Agreement.

) Installation Process Interface

Click Install to enter into the Installation Process interface. This interface is mainly used for the installation of driver softwares.

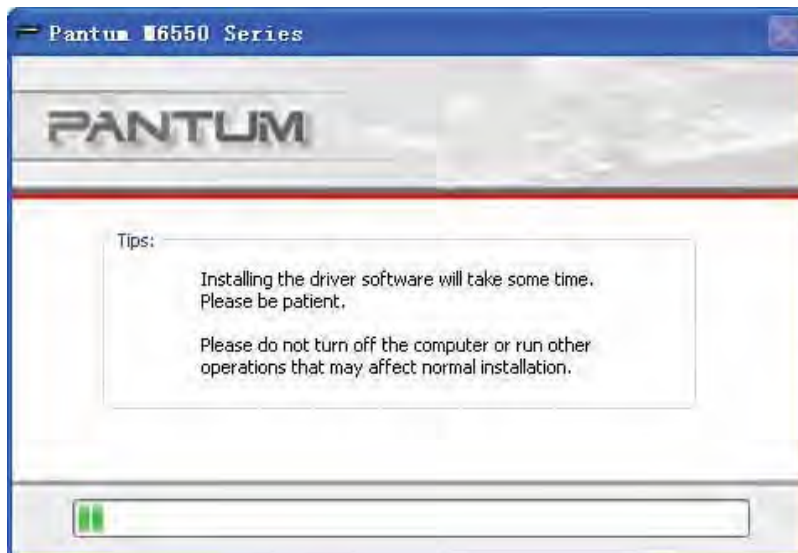

) Installation Complete

The program will automatically enter into this interface after the driver installation is completed. It will automatically exit in 3 seconds and set the printer as default.

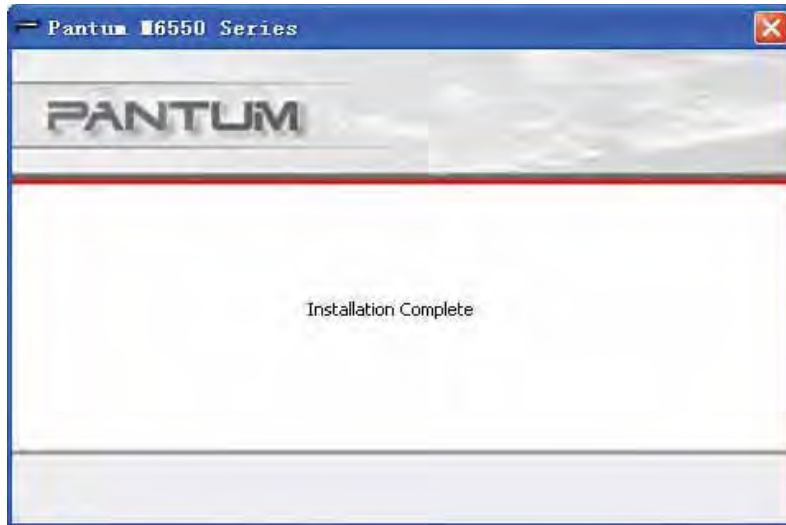

odel Wired and Wireless et or s

1) Running Interface

fter inserting the installation C , the Pantum interface will pop up and the installation C will run automatically. See the figure below:

PANTUM

User authentication will be performed before the program runs. If the user is an administrator, this interface will be displayed. If the user is not an administrator, the prompt of "Insufficient privileges. Please install the printer with administrator privileges" will pop up.

a) Installation Configuration

After the running interface ends, it will enter into Installation Configuration interface. Users will select the corresponding series, language and model according to the purchased printer model.



Installation Instruction:

USB Printer: applicable to USB Model offline or wired installation (the printer disconnected with the computer); or NET Model with USB Installation (disconnected to the Internet).

Printers connected to the network: applicable to NET Model Network Installation; or Wi-Fi Model connected to the Internet and reinstallation.

Printers connected to a new network: applicable to first-time Wi-Fi Model Installation, network configuration.

Wired Model Installation

1) The following interface will display, if users install the Net Model:



Users select Net Model through "Select Printer" and 2 installation options are available through Installation mode.

) Search for Printer Interface:

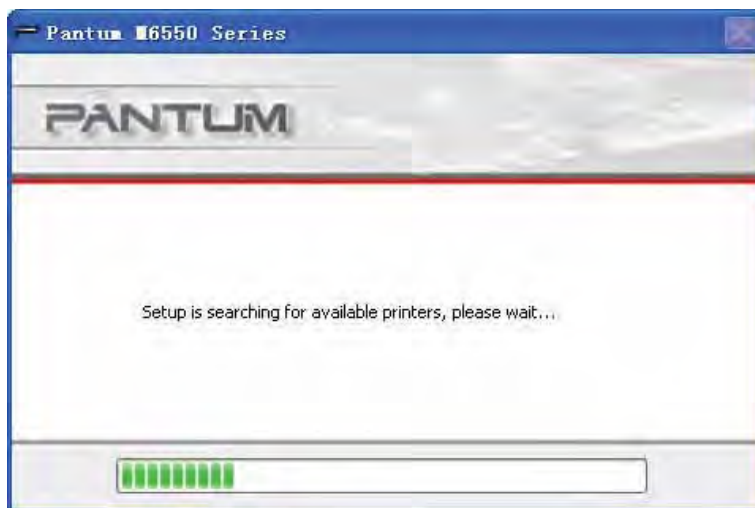

After entering Search for Printers interface, the program will automatically search whether appropriate printer devices are connected to the computer.

) Printer list

After searching for printer, the program will automatically enter into "Detected Printer" interface. Users can select the found printer or add printer by manually adding IP or Host name.



) Printer Installation Interface

Click on "Next" in "Printer List" interface, the program will enter into "Printer Installation interface". After installation is completed, it will enter into "Installation Complete" interface, and exit in 3 minutes and set the printer as default.

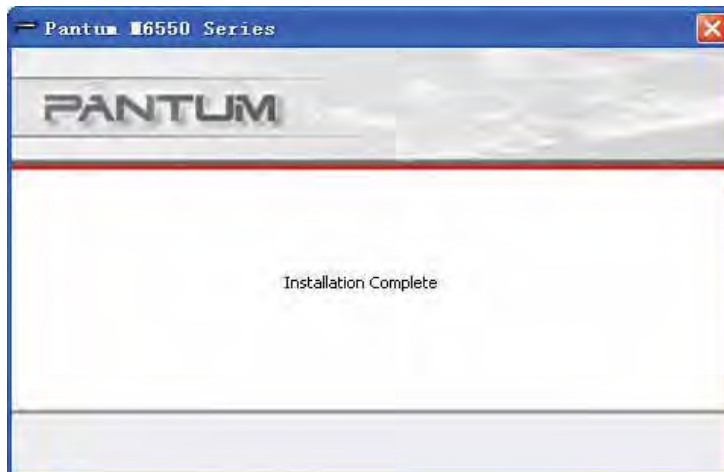

Wi-Fi Model Installation Wi-Fi

1) If users install the Wi-Fi Model, the following interface will display:



Users select Wi-Fi Model through "Select Printer", and 3 installation options are available through Installation mode. Generally, users select the third installation method at the first-time installation.

2) Wi-Fi Configuration Interface

At the first installation, user will install Wi-Fi Model through Wi-Fi Configuration interface and connect the printer to Wi-Fi. Please refer to Chapter 5.2.1 to see the specific setting steps of Wi-Fi configuration tools.

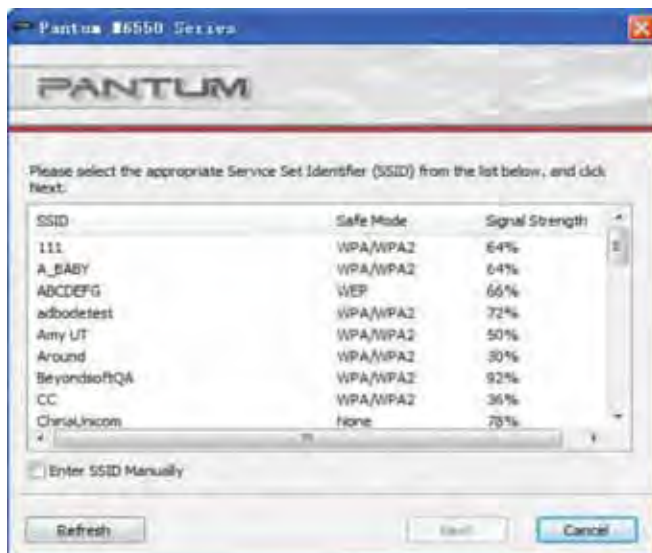

During the driver installation, if "Windows can not verify the publisher of this driver software" pops up to ask users whether to continue installation or not, users should click on "Always install this driver software". System warning interface may differ slightly in different operating systems.



) Installation Complete Interface

This interface indicates that the installation is completed.

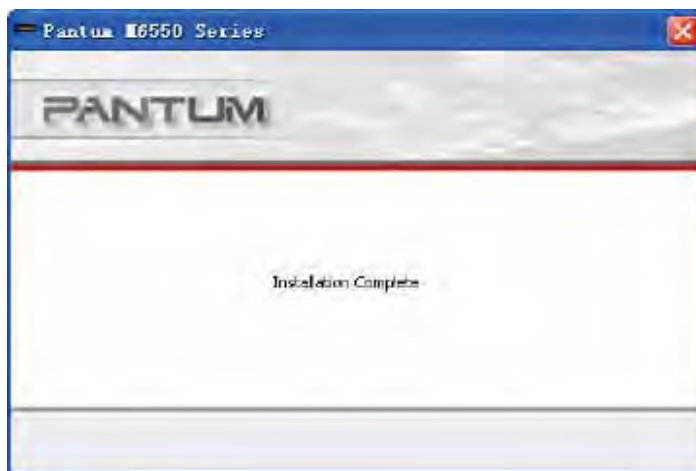

ninstallation

1) Select Uninstallation Mode.

In the "Start" menu, select Pantum uninstallation icon to enter the uninstallation interface or find "Add/Remove" and relevant Pantum options in the PC Control Panel, and click on "Change and Delete". Delete interface will pop up. Users can select to uninstall the printer that needs to be uninstalled.



2) Uninstallation Privilege Verification

ninstallation requires administrator privileges. If a non-administrator runs the uninstaller, this prompt will pop up: "Insufficient privileges. Please uninstall the printer with administrator privileges."

If any task remains in the print queue, a warning will pop up, saying "Pantum M6550 Series laser printer is printing. Please uninstall the driver after the printing is completed."

) ninstallation Interface

After selecting the printer, click on "Remove One" or "Remove All" to enter into Uninstallation interface.

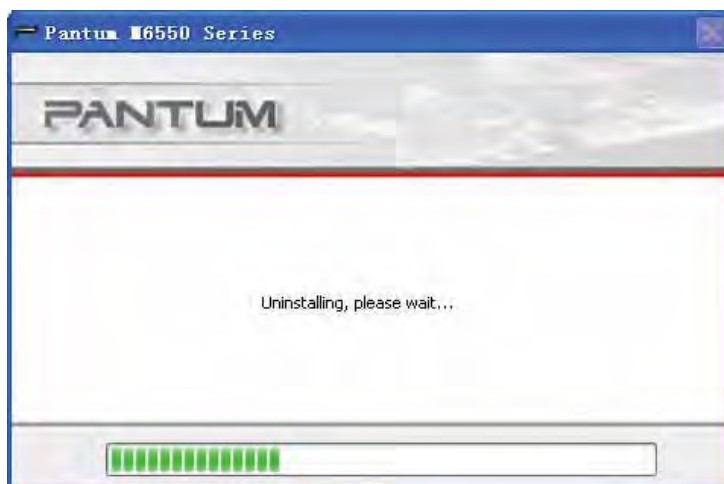

) Complete Interface

After the uninstallation progress bar completes, the program will automatically switch to Uninstall Complete Interface. Click "Done" to finish the uninstallation successfully.



Click "Done" button, the following window will pop up prompting you to restart the computer. Click "OK" to exit the uninstaller and restart the computer; click "Cancel" to exit the uninstaller.



ote: • If you choose not to restart the computer after the uninstallation is completed, an unsuccessful installation or scan abnormality after installation may occur when reinstalling the driver.

Introduction

Introduction

Mac driver installer is made by using the PackageMaker software that comes with the Mac System. The installation style is basically consistent with the installation of the ordinary software under Mac.

The installation is divided into the following steps: introduction, license, destination select, installation type, installation, summary.

Installation Steps

1. Introduction

Insert the CD-ROM into the CD-ROM driver, run the CD-ROM and click the installation package for Mac, then the following interface will be displayed:



License Agreement

Click "Continue" on the above figure to display the contents of the License Agreement, as shown below:



Click "Continue", the dialog box of "To continue installing the software, you must agree to the terms of the Software License Agreement" will pop up.

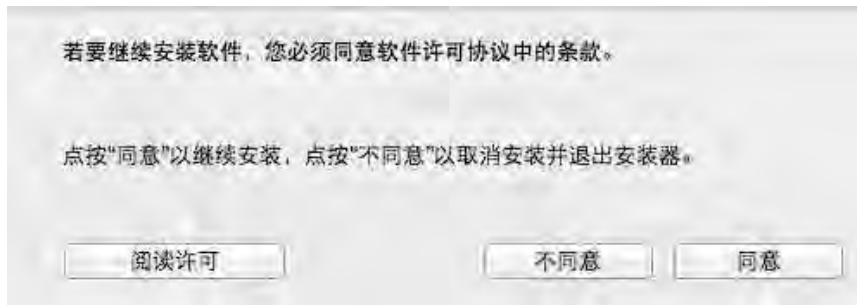

Click "Agree" to accept the License Agreement and continue the installation.

3. Installation Type

Click "Continue" on the above figure to display the installation-related information, as shown below:



Click "Install", the following prompt box will pop up. Only after getting permission from the administrator user can you continue with the installation.

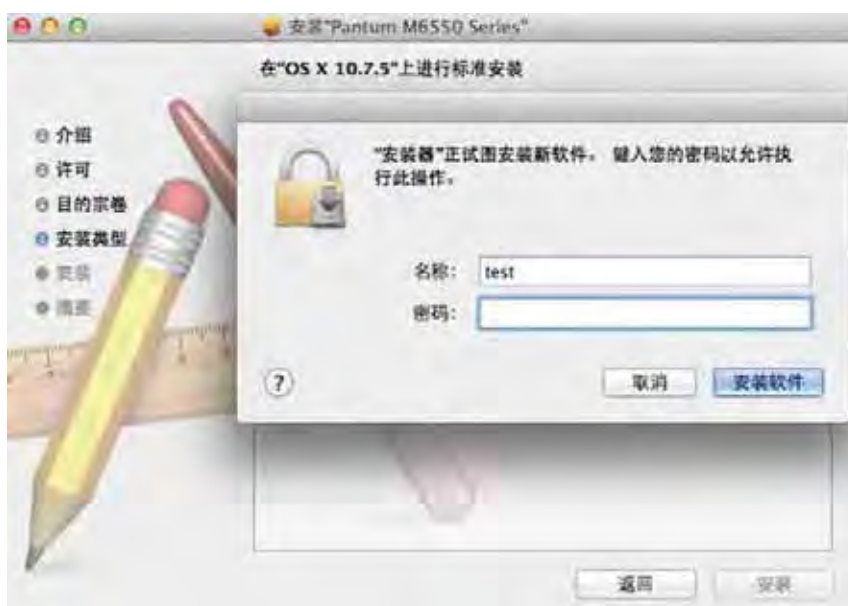

. Installation

Click "Install" after filling in relevant information on the above figure, the installation progress will be displayed, as shown below:



5. Summary

After successful installation is displayed. Click on "Restart" to complete the installation, as shown below:



Wired Network Setting (For printer models that support wired network printing)

4

Chapter

4. Wired Network Settings (For printer models that support wired network printing)	2
4.1. Install the Printer to Network.....	2
4.2. Control the Network Printer	2
4.2.1. View or Change Network Settings	2
4.2.2. Set or Change Web Server Login Password	2

4. Wired Network Settings (For printer models that support wired network printing)

Printers that support wired network printing can be connected to the Internet, thereby the printer will work under the control through a wired network.

4.1. Install the Printer to Network

Please refer to Chapter 3.1. to see the installation steps of NET Model.

4.2. Control the Network Printer

User can control the network settings through the built-in WEB Server in the printer.

4.2.1. View or Change Network Settings

- 1) From the printer's Control Panel, using the steps in Chapter 7.1.6., print the report of the printer's network configuration information and check it to get the printer's IP address.
- 2) Type the IP address into the Web browser's address bar to access the embedded Web server of the printer.
- 3) Complete the settings of the Networking Protocol, wireless network, Wi-Fi hotspot, address list, e-mail and other relative configuration information in the "Setting".

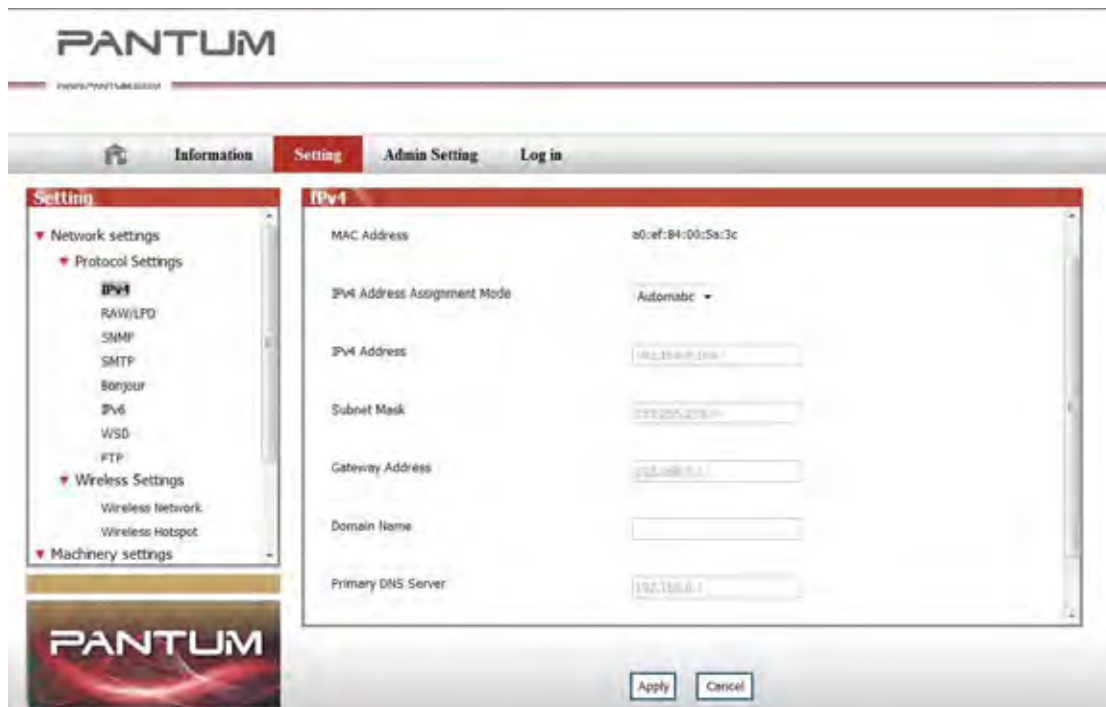

4.2.2. Set or Change Web Server Login Password

You can control the printer using the administrator settings.

Steps:

- 1) After opening the built-in WEB server, log in (default user name is admin, default password is 000000).
- 2) Click "Administrator Settings" to conduct corresponding operations.

Wireless Network settings (for models with Wi-Fi printing)

5

Chapter

5. Wireless Network settings (for models with Wi-Fi printing)	2
5.1. Configuration via Button	2
5.2. Configuration via USB Connection	2
5.2.1. Wi-Fi Configuration Tool	2
5.3. Wi-Fi Hotspot Configuration	5
5.4. Turn off Wireless Device	5

5. Wireless Network settings (for models with Wi-Fi printing)

Based on models, printers with Wi-Fi printing support two types of wireless connection, Infrastructure Connection Mode and Wi-Fi hotspots. Generally, only one type of connection can be used between the computer and the printer each time.

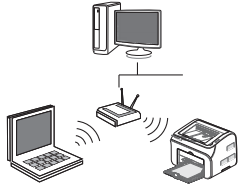

Infrastructure Connection Mode

The printer communicates with the wireless device via the access point.

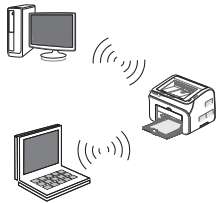

Wi-Fi Hotspot

The wireless computer is directly connected with the wireless device.

5.1. Configuration via Button

If the printer connects with the wireless router that supports WPS, wireless network can be easily configured via the Wi-Fi button on the control panel.

Configuration: Press and hold “Wi-Fi” button on the printer’s Control Panel to launch WPS. Press the WPS button on the wireless router after 2 minutes of the launching, then the printer will be connected to the wireless network.



Note: • Wireless Router needs to support WPS mode

- The WPS can be configured only when the network cable is unplugged
-

5.2. Configuration via USB Connection

USB Connection Configuration means using USB cable to connect the printer with the computer, then launch the wireless network configuration tool on your computer and conduct wireless network configuration on the printer.

5.2.1. Wi-Fi Configuration Tool

Wi-Fi configuration tool is a computer software that helps users to set the printer SSID, encryption method and password. Turn on the Wi-Fi configuration tool in the driver installation package. The specific steps are as follows:

1) Detect Wireless Network Card

Wi-Fi configuration tool can search the wireless network automatically by a wireless card in the computer. If the computer does not have a wireless card, the option of “Manually Enter the SSID” will be automatically checked on the “Wireless Network List” page.

) wireless network list

After launching the configuration tool, the Wireless Network List interface will be displayed to provide selection function of wireless network.

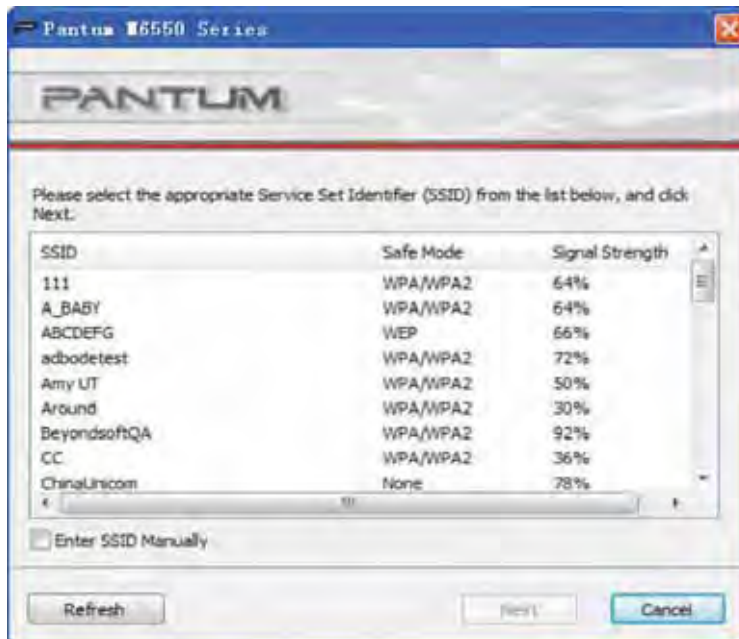

Users can select an item in the list, and then click on “Next” to enter the Information Input interface, or manually input the SSID on the bottom left corner.

3) Manually Enter SSID

Click "Enter SSID Manually" to switch to the interface of manually entering the SSID.



Input the needed SSID in the “SSID” bar; Click on “Print the Wireless Network Page” to get the list of the found wireless networks.

4) Input Configuration Information

Entering the Input Information interface, users can set relative information of the wireless network.

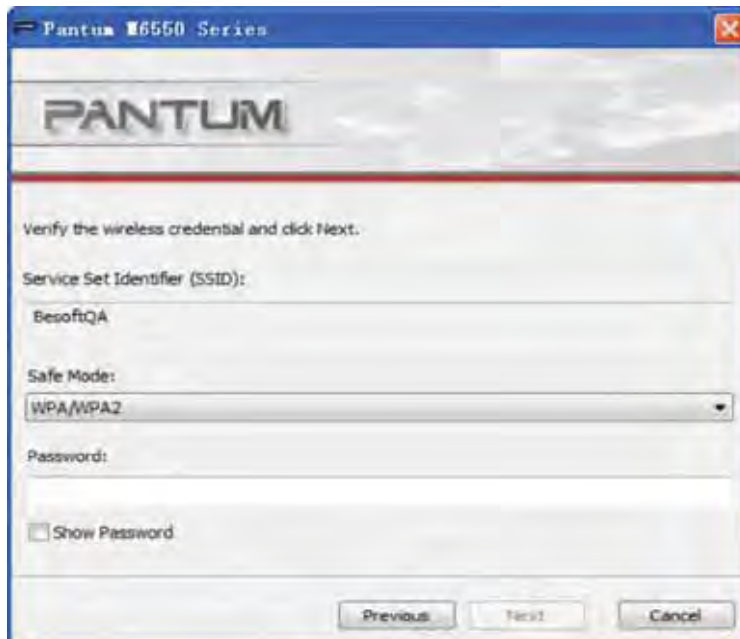

The screenshot shows a window titled "Pantum 6550 Series" with a close button in the top right corner. The window contains the Pantum logo at the top. Below the logo, the text reads "Verify the wireless credential and click Next." The "Service Set Identifier (SSID):" field contains the text "BesoftQA". The "Safe Mode:" dropdown menu is set to "WPA/WPA2". The "Password:" field is empty. There is a checkbox labeled "Show Password" which is currently unchecked. At the bottom of the window, there are three buttons: "Previous", "Next", and "Cancel".

After the configuration, click on "Next".

5) Configuration Completed

After completing the above steps, the Wireless Network Configuration Result interface pops up. The configuration result will be displayed.

If the configuration of the printer's wireless network is successful, the following interface will pop up:



The screenshot shows a window titled "Pantum 6550 Series" with a close button in the top right corner. The window contains the Pantum logo at the top. Below the logo, the text reads "Wireless connection successful". The main text in the window says "The printer can successfully connect to a wireless network with the wireless credentials provided." At the bottom right of the window, there is a button labeled "Done".

5.3. Wi-Fi Hotspot Configuration

When the wireless hotspot of printer is active, the user can connect to it directly by searching. The wireless hotspot is enabled by default, and the default password is 1234567890. The printer-specific SSID and password can be obtained from WiFi Configuration Information Page, which can be printed out by selecting Print WiFi Configuration. After establishing the connection, the configuration can be completed according to the Web configuration method.

5.4. Turn off Wireless Device

If you want to disconnect the printer with the wireless network, you can turn off the wireless device in the printer.

- 1) Users can disconnect the wireless network by pressing the “Wi-Fi” button on the printer's control panel for over 5 seconds.
- 2) To verify whether turn off successfully or not, users can check whether the Wi-Fi button is on or not, or print the network configuration information to check the wireless network status.

Pantum Mobile Print and Mobile Scan

6

Chapter

6. Pantum Mobile Print and Mobile Scan	2
6.1. Introduction to Pantum Mobile Print and Mobile Scan.....	2
6.1.1. What's Pantum Mobile Print and Mobile Scan?	2
6.1.2. Download Pantum Mobile Print and Mobile Scan.....	2
6.1.3. Supported Mobile Operating System	2
6.2. Operation Steps for Mobile Print.....	2
6.2.1. For Android Devices.....	2
6.2.2. For Apple IOS Devices (iPad, iPhone, etc).....	4
6.3. Operation Steps for Mobile Scan.....	6
6.3.1. For Android Devices.....	6
6.3.2. For Apple IOS Devices (iPad, iPhone, etc).....	9

Pantum Mobile Print and Mobile Scan

Introduction to Pantum Mobile Print and Mobile Scan

What's Pantum Mobile Print and Mobile Scan

Pantum Mobile Print and Mobile Scan is a free application, which allows users to directly print photos, documents, WebPages, scanned photos and scanned documents from the mobile terminal.

It connects your mobile device with wireless printer through Wi-Fi access points. You just need to install the Pantum Mobile Print application for configuring the network settings, then it will automatically detect compatible Pantum printer to print, which is very convenient and efficient.

Download Pantum Mobile Print and Mobile Scan

To download the Pantum Mobile Print and Mobile Scan application, please visit Pantum official website www.pantum.com.

Supported Mobile Operating System

It is available to mobile operating systems with Android 4.0 or later versions and supports a resolution of 300 dpi or higher.

Mobile Scan supports iOS 4.0 or later versions

Operation Steps for Mobile Print

For Android Devices



Note: •Pantum mobile printing for Android system, the current product supports only for printing text documents, images or web pages, but not for printing documents in PDF, Word, Excel, PPT, etc.

1. Turn on the printer.

Launch the Wi-Fi in the mobile device, connect it with the Wi-Fi hotspot of Pantum printer (For example, the Wi-Fi hotspot may display as Pantum- P-XXXXXX).

If there are several Pantum Wi-Fi printers, when you select the printer hotspot, please tap Menu Button on the printer to be used, select Information Report and select Print Wi-Fi Configuration. Then, the printer will print out WiFi Configuration Information Page. View the hotspot name of SSID in WiFi Configuration Information Page, and connect to the appropriate hotspot with your mobile phone.

. Launch mobile Print app to enter into home page.



. Select any item from the menu, such as Print from Album, select pictures you need to print, click on Print Setting on the top right corner.



. Select printer, number of copies and paper size, click on Print on the top right corner to start printing.

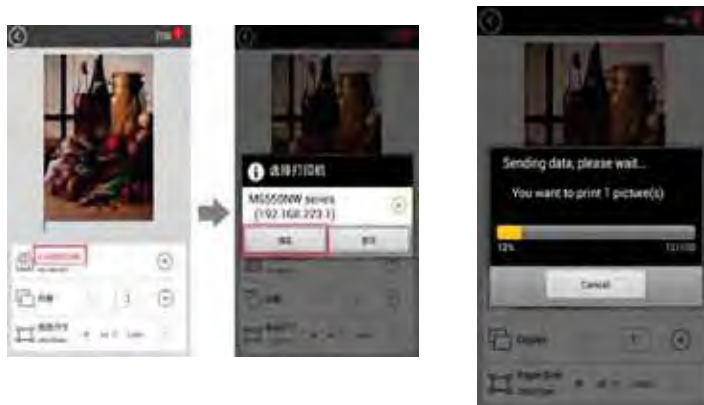

Note: • Install mobile Print app (Select from QR Code, Google Play Store, Pantum official website, etc.).

• Scan the QR Code on the printer, go to www.pantum.com or directly download our mobile Print app from Google Play Store and install the application in the mobile device.

6.2.2. For Apple IOS Devices (iPad, iPhone, etc)

1. Turn on the printer.
2. Launch the Wi-Fi in the mobile device, connect it with the Wi-Fi hotspot of Pantum printer (for example, the Wi-Fi hotspot displays Pantum-AP-XXXXXX).

If there are several Pantum WiFi printers, when you select the printer hotspot, please tap Menu Button on the printer to be used, select Information Report and select Print WiFi Configuration. Then, the printer will print out WiFi Configuration Information Page. View the hotspot name of SSID in WiFi Configuration Information Page, and connect to the appropriate hotspot with your mobile phone.

3. Select the file you need to print (for example, the folder "Picture").
4. Click on "Photos" icon (as is shown below) to open the folder "Photos".



5. Select pictures you need to print, the following interface pops up:



6. Click on “” icon on the bottom left corner, the following interface pops up:



. Click on **Print** on the bottom left corner, the following interface pops up:



. Click on **Select Printer** to select the corresponding printer.

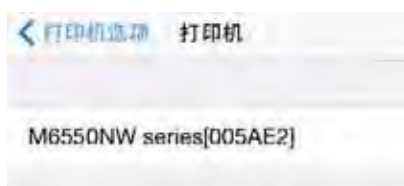

. Select the number of copies.



1 . Click on **Print** to start printing.



6.3. Operation Steps for Mobile Scan

6.3.1. For Android Devices

1. Turn on the printer.
2. Launch the Wi-Fi in the mobile device, connect it with the Wi-Fi hotspot of Pantum printer (for example, the Wi-Fi hotspot displays Pantum-AP-XXXXXX).
3. Launch Mobile Print App to enter into home page.



4. Click on “Mobile scanning”, the Scan List displays.





Note: Click on the document in the list to enter into the Operation interface, select “Print” or “Share” and the specific operations are as follows:



1) Click on “Print” to print document:



2) Click on “Share” to share the application:

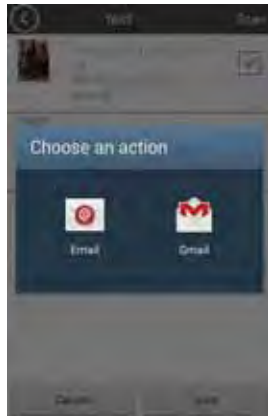

5. Click on “Scan” on the top right corner, enter into Scan interface.



6. Click on “Click to select scanner” at the top of the interface, select a scanner, the following interface pops up:



7. Click on “Search”, the page displays “Searching scanner”, Click on “OK” after completing searching.



8. Click on “Add IP Address”, the following interface pops up, input the IP address, then click OK.



9. Set the scan parameters below the interface. Click “Start” on the top right corner to start printing.

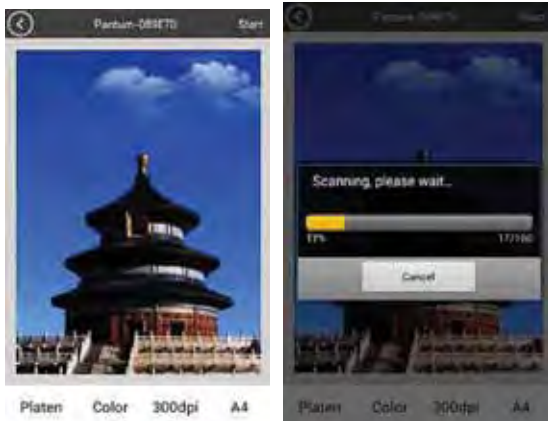

10. After the scan is finished, click on “Done” on the top right corner, the following interface pops out to prompt to input the title of the document.

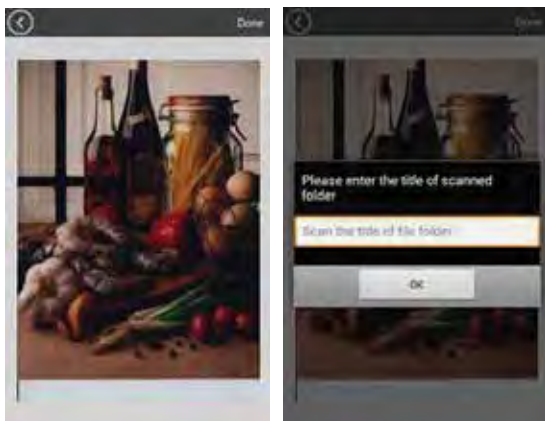

6.3.2. For Apple IOS Devices (iPad, iPhone, etc)

1. Turn on the printer.
2. Launch the Wi-Fi in the mobile device, connect it with the Wi-Fi hotspot of Pantum printer (for example, the Wi-Fi hotspot displays Pantum-AP-XXXXXX).
3. Launch the Pantum Scan APP icon (as is shown below), enter into the following interface:

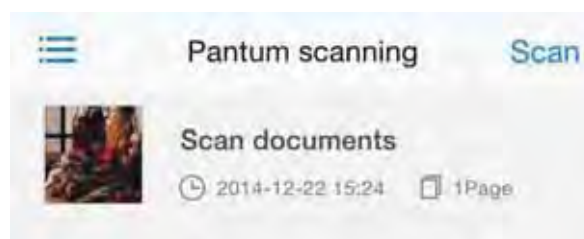

4. Click on “Menu” on the left side, Sidebar interface pops up, you can enter into the Pantum Mall, and check the version and copyright of the Pantum Mobile Scan.



5. Click on “Pantum scanning”, the Scan List displays:

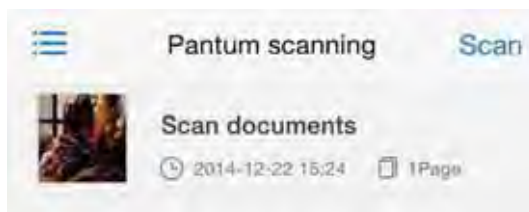

6. Click on “Scan” on the top right corner, enter into Scan interface:



7. Click on “Select scanner”, the following window pops up:



. Click on Search , the page displays Searching scanner , the interface is as shown below and click on after completing searching.

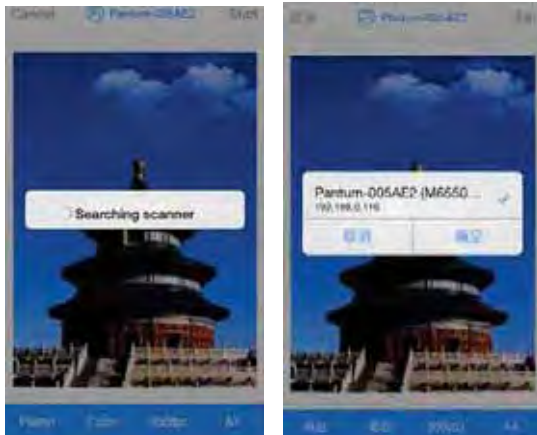

. Click on dd IP address in the middle of the navigation bar, the following interface pops up:



1 . Click on Scan Parameters at the bottom of the page, the following parameters setting panel pops up:



11. Click on “Start” on the top right corner, start scanning.



12. After the scan is finished, if you still need to scan, click on “Resume” on the top right corner; if not, click “Done” on the top left corner, the following interface pops up to prompt to input the title of the document.



General Settings

7

Chapter

7. General Settings.....	2
7.1. System Settings.....	2
7.1.1. Toner Save Setting.....	2
7.1.2. Language Setting	4
7.1.3. Restore to Factory Settings	4
7.1.4. Sleep Time Setting.....	5
7.1.5. Network Settings.....	5
7.1.6. Network Information.....	6

7. General Settings

This chapter mainly introduces some general settings of the control panel's menu.

7.1. System Settings

7.1.1. Toner Save Setting

Users can select Toner Save Setting to lower the cost of printing. When the Toner Save mode is "On", the output color of the copy will be lighter. Default Setting is "Off".

1) Press "Menu" button to enter the menu interface.

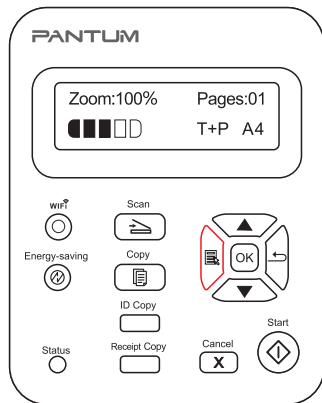

2) Press direction pad "▲" or "▼" to select "3. System Settings" and press "OK" button.

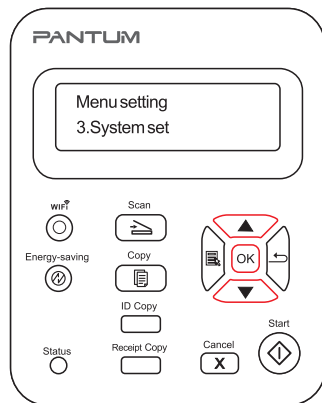

3) Press direction pad "▲" or "▼" to select "1. Toner Save Setting" option and press "OK" button.

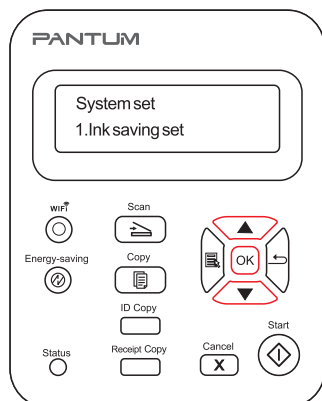

4) Press direction pad "▲" or "▼" to select "1. Close" and press "OK" button. When symbol "*" appears after "1. Close", it indicates that the toner save setting is off; or press direction pad "▲" or "▼" to select "2. Open" and press "OK" button. When symbol "*" appears after "2. Open", it indicates that the toner save setting is on.

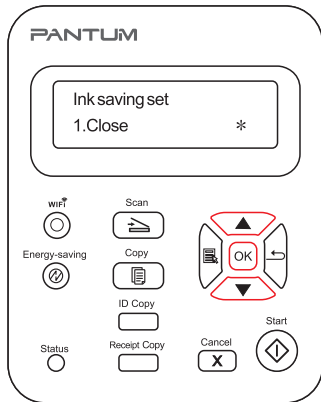

5) Press "Menu" button to exit the menu interface, or select the "Back" which is the last item of each menu, and press "Menu" button to exit the menu interface step by step.

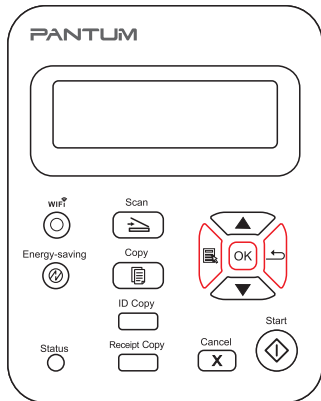

Note: • For non-Wi-Fi Model Printer, the Wi-Fi button works as one-key toner saving button.

- When this menu is placed on the bottom interface of selecting "Close/Open", symbol "*" of the options displayed in the menu will not update in time after changing toner save setting via one-key toner saving button. Users need to go back to the previous menu to re-enter this menu, the changed Toner Save Setting information will be displayed.

7.1.2. Language Setting

"Language Setting" is used to select the language to be displayed on the control panel . The default language is Chinese.

- 1) Press "Menu" button to enter the menu interface.
- 2) Press direction pad "▲" or "▼" to select "3. System Settings" and press "OK" button.
- 3) Press direction pad "▲" or "▼" to select "2.Language Setting" and press "OK" button.

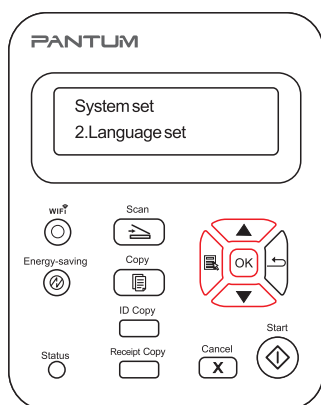

Note: • Product's actual region determines the Language Setting.

7.1.3. Restore to Factory Settings

"Restore Factory Settings" is used to restore the default settings of the printer.

- 1) Press "Menu" button to enter the menu interface.
- 2) Press direction pad "▲" or "▼" to select "3. System Settings" and press "OK" button.
3. Press direction pad "▲" or "▼" to select "3. Restore to Factory Settings" option and press "OK" button.

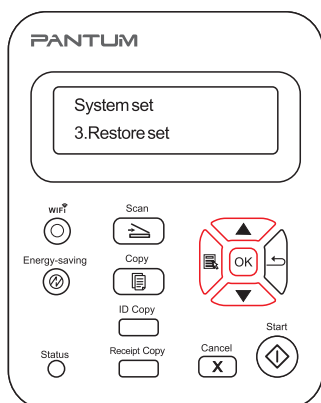

7.1.4. Sleep Time Setting

Set the Sleep Time Mode to lower the power consumption. "Sleep Time Setting" allows users to select the idle time before the device enter into Sleep Mode. The default idle time is 1 minutes.

- 1) Press "Menu" button to enter the menu interface.
- 2) Press direction pad "▲" or "▼" to select "3. System Settings" and press "OK" button.
- 3) Press direction pad "▲" or "▼" to select "4. Sleep Time Setting" and press OK button.
- 4) The direction pad "▲" or "▼" can be used to select "1 Minute", "5 Minutes", "15 Minutes", "30 Minutes", and "60 Minutes".

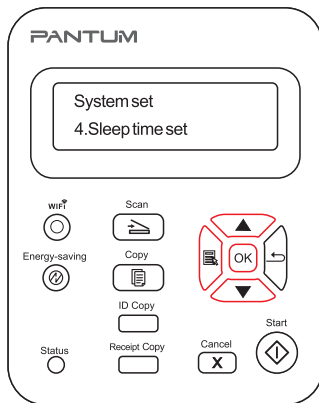

Note: • When the printer is in dormant status, it can be woken up only by pressing Power Saving button or sending print/scan task.

7.1.5. Network Settings

Users can set the network status through Network Settings.

- 1) Press "Menu" button to enter the menu interface.
- 2) Press direction pad "▲" or "▼" to select "3. System Settings" and press "OK" button.
- 3) Press direction pad "▲" or "▼" to select "5. Network Settings" option and press "OK" button.

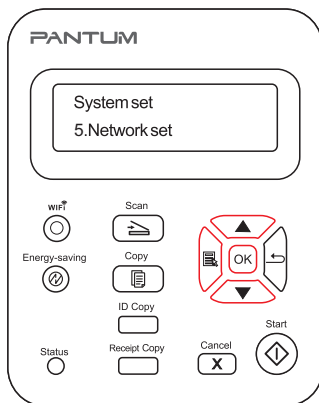

4) Press direction pad "▲" or "▼" to select "1. Wired config." and press "OK" button; Press direction pad "▲" or "▼" to select "1. IPv4" or "2. IPv6".

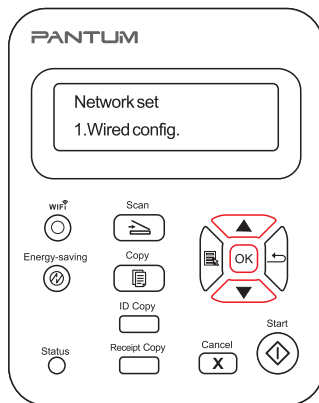

5) Press direction pad "▲" or "▼" to select "2. Wireless Network Settings" and press "OK" button; Press direction pad "▲" or "▼" to select "1. WPS PIN Mode".

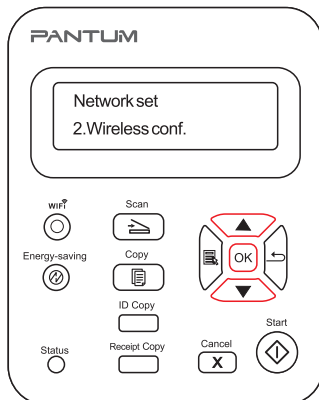

7.1.6. Network Information

Users can check the network status through Network Information.

1) Press "Menu" button to enter the menu interface.

2) Press direction pad "▲" or "▼" to select "3. System Settings" and press "OK" button.

3) Press direction pad "▲" or "▼" to select "6. Network Information" option and press "OK" button.

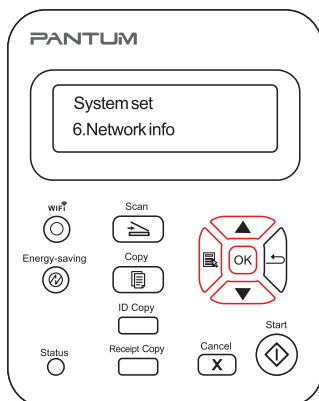

4) Press direction pad "▲" or "▼" to select "1. TCP/IP", "2. Wi-Fi Information".

5) Select "1. TCP/IP" option and press "OK" button, press direction pad "▲" or "▼" to select "1. IP Address", "2. Subnet mask" and "3. Gateway".

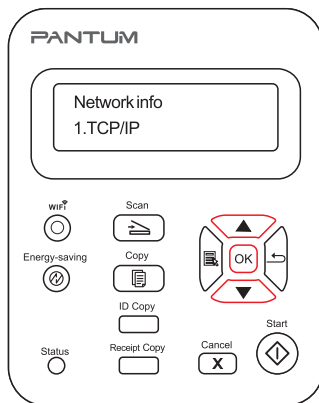

6) Select "2. Wi-Fi Information" option and press "OK" button, press direction pad "▲" or "▼" to select "1. MAC Address", "2. Wi-Fi Status", "3. Wi-Fi Channel" or "4. SSID Information" (The display of SSID Information only supports English letters and numbers).

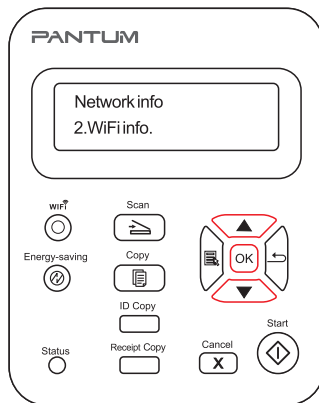

Print

8

Chapter

- 8. Print 2
 - 8.1. Print Function..... 2
 - 8.2. Open Help Document 3
 - 8.3. Duplex Print 4
 - 8.4. Cancel Print Job 7
 - 8.5. Mac System Print..... 7

8. Print

8.1. Print Function

You can set the print function through "Start"->"Device and Printer"- select corresponding printer- right click – set print function in "Print Preferences". Some functions are as follows:

Functions	Diagram
Manual Duplex	
Collate Print	
Reverse Print	
N-in-1	
Poster Print (for Windows Operation System only)	
Zoom Print	
Custom Size	



- ote:**
- You can select the 2 x 2 Poster Print in N-in-1 to enable the poster printing function.
 - You can open the Printing Preferences and click Help button to check the specific function explanation. For information about how to open the help document, see Chapter 8.2.

en el ocument

You can open the "Printing Preferences" and click "Help" button (for Windows Operation System only). The help document contains the user guide where you can find the information on print settings.



u le Print

1) The printer driver supports manual duplex.



-
- ote:**
- If the paper is thin, it may wrinkle.
 - If the paper is curled, make it flat and put it back into the manual feeder tray.
 - If the manual duplex function causes a paper jam, see Chapter 12.1 for handling it.
-

2) Ensure that certain amount of paper is loaded into the automatic feeder tray before printing.



-
- ote:**
- For loading paper, see Chapter 2.4.
 - For the media types that support printing, see Chapter 2.1. It is recommended to use the standard paper.
 - Some paper media are not suitable for the duplex printing. Trying the duplex printing may damage the printer. When "Paper Type" is "Thick Paper" or "Transparent Film", please do not try "Duplex Print". If you choose "Reversed Order" printing in Printing Preferences dialog box, Manual Duplex will not be supported when "2 x 2 Poster" printing.
 - Paper will get jammed or cannot be fed in when the automatic feeder tray is loaded with more than 150 papers.
-

3) Printing steps are as follows (for Windows Operation System only) :

a) Open the document to be printed from the application (such as Notepad), and select "Print" from the "File" menu.

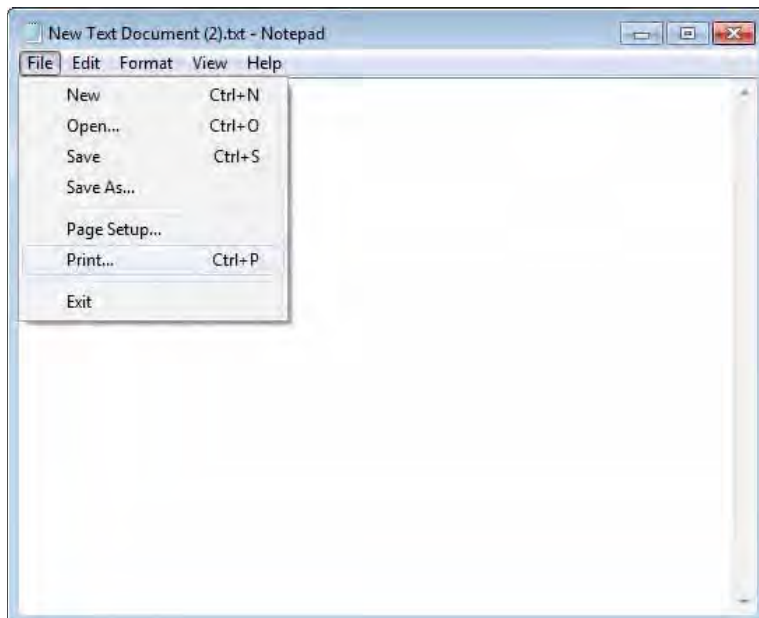

b) Select Pantum printer



Click "Preferences" to set printing.

c) Set options in "Manual Duplex" of the "Basic" tab and click "OK" after completing the settings.



d) Click "Print".

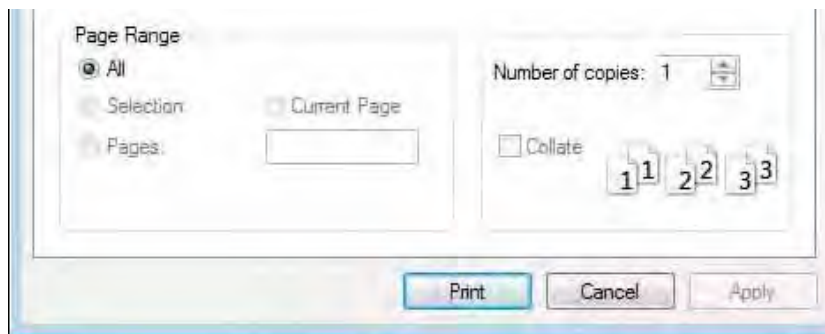

ote: • It is recommended to raise the output tray to prevent the paper from sliding out of it. If you choose not to raise the output tray, we recommend that you immediately remove the printed paper output from the printer.

e) Send the print task after choosing Manual Duplex, then the following prompt window will appear, telling you the next specific operations. Interfaces are different depending on the models.



f) After turning over the paper according to the prompt, press "OK" button of the printer to go on printing the other side.



g) You can click "Close" button to close this prompt window, and it will not appear until the next Manual Duplex job comes in.

ancel Print o

Press and hold the "Cancel" button on the control panel to cancel the print job you want to cancel during the printing process, or cancel print job in printing pool.

ac System Print

eration Steps

1. After installing the printer's driver, click on "System Preferences" on the bottom left corner.



2. After the window pops up, click on "Print and Scan".



3. After the window pops up, select "Print".



4. Select printer

1) For USB Model printer: plug the USB cable, the corresponding printer will automatically show in the left list.

2) For NET Model printer: plug the network cable, click on symbol "+" at the bottom of the left list to add printer.



3) For Wi-Fi Model printer: select the Wi-Fi icon on the top right corner of the page, click on "Open Network Preferences" in the list.



After the window pops up, click on SSID.



Select the corresponding SSID.



5. Open the document to be printed, click on "Document" – "Print".

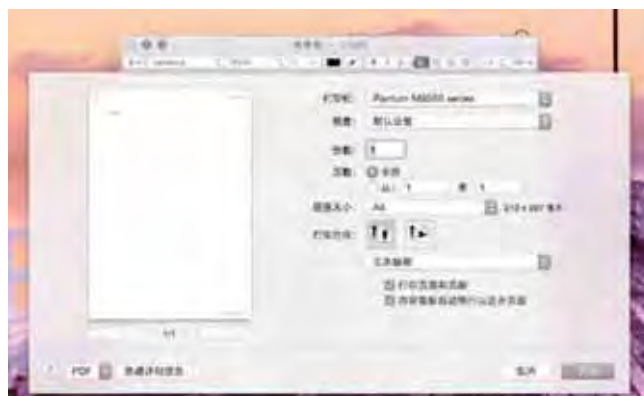

After the window pops up, set the printing parameters, and press the "Print" button on the top right corner.

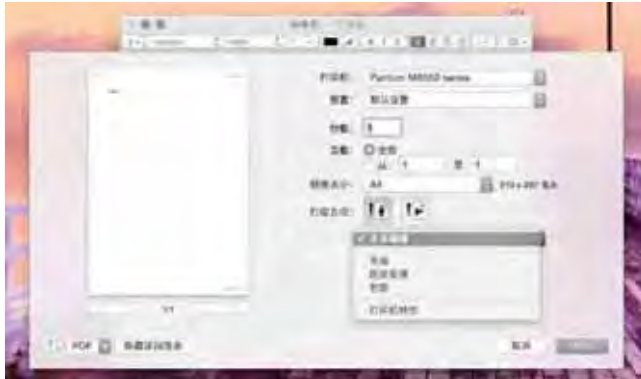

Copy

9

Chapter

9. Copy	2
9.1. Plain Copy	2
9.2. Bill Copy.....	3
9.3. ID Card Copy	3
9.4. Cancel Copy Operation	5

9. Copy

9.1. Plain Copy

1. Put the manuscript face down into the glass platen.

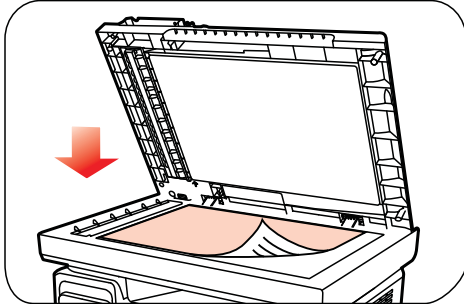

Note: • During copying, please do not open the cover to avoid any adverse impact on the image quality.
• For the information on "Steps of Using Paper and Manuscript", please refer to Chapter 2.5.

2. Press "Copy" button on the control panel, press "OK" to enter the copy mode.

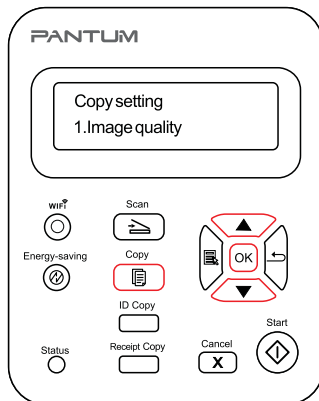

Note: • The printer will enter copy mode automatically when restart or startup.

3. Press direction pad "▲" or "▼" to select "1. Resolution", "2. Color Intensity", "3. Zoom", "4. N-in-1", "5. Clone" or "6. Paper Setting" to set copy.
4. Press "Start" button to start copy.

9.2. Bill Copy

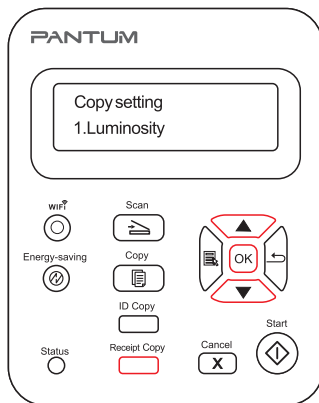

Press this button to enter "Bill Copy" mode, which is used to output high-sharpness bill copy.

Steps of Bill Copy:

1. Press "Bill Copy" button to enter the "Bill Copy" mode, and then the area on the main LCD interface to display image quality will change to display "Bill";
2. Put the bill on the scanning platform and press "Start" button, then the LCD will prompt "Copying...";
3. The bill will be printed out after completing the scan.

9.3. ID Card Copy

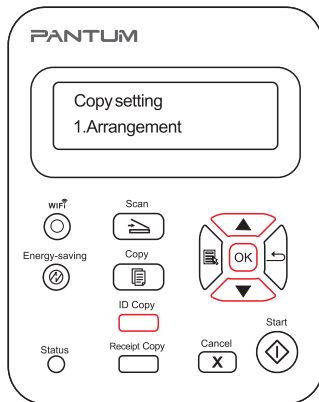

Press "ID Card Copy" button to enter "ID Card Copy" mode. It is used to copy ID Card and other two-sided certificates.

Steps of ID Card Copy:

1. Press "ID Card Copy" button to enter the "ID Card Copy" mode. The printer of this model supports four types of ID Card copy, namely full page top to bottom, half page top to bottom, half page left to right, A5 long side, examples are as follows:

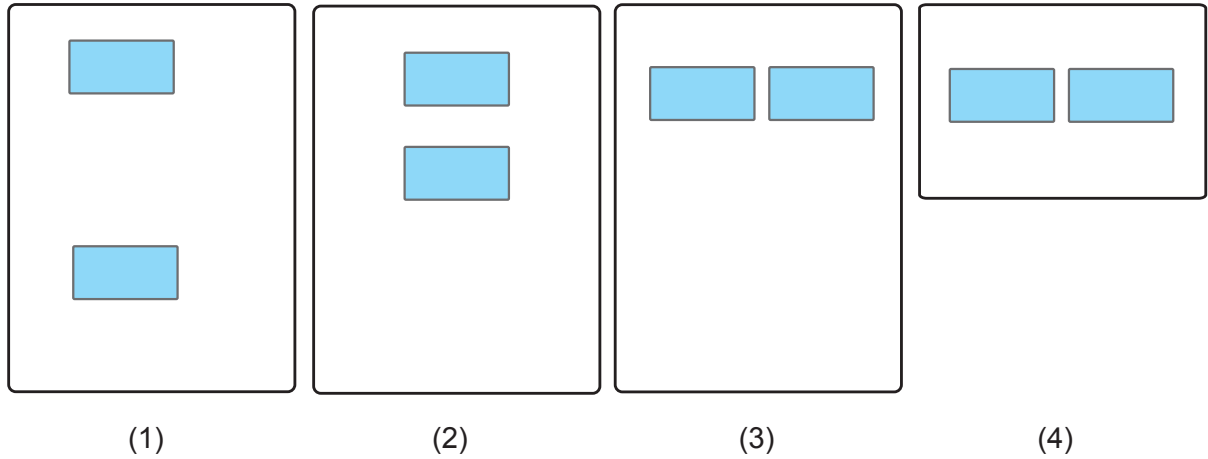

2. Put the ID Card on the left half of the scanning platform. The orange part is the placed area of ID Print Type 1, while ID Print Type 2, 3, 4 are in the blue part. The corresponding top and left sides of the blue part on the scanning platform are marked with scale line. The distance between the blue part and the boundary is 5mm. Press "Start" button to start scan, then the LCD will prompt "Copying...";

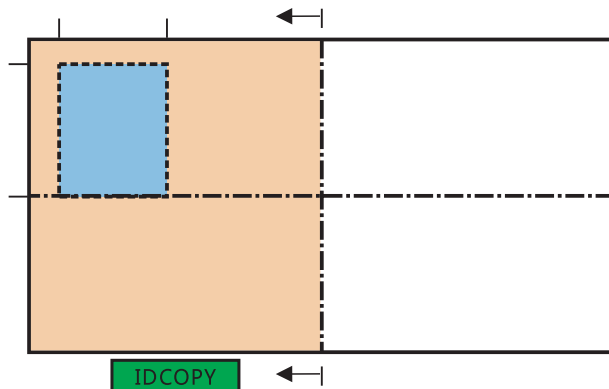

3. After finishing scanning the one side of the ID Card, the first line of the LCD prompts "Flip the ID Card: Start", the second line displays "Scan Completed: OK".

4. If the scanning of the second side of the ID Card is required, please open the cover to flip ID Card and keep it in the same area. After pressing down "Start" button, LCD will prompt "Copying..."; After completing scan, the front back of the ID Card will be copied to the same page of the same paper;

5. If only one side is required, then press "OK" button to end scanning. This time only one

side of the ID Card is copied to one side of the paper.

9.4. Cancel Copy Operation

If you want to cancel the copy operation, please press "Cancel" button. The LCD Screen will prompt "Canceling....".

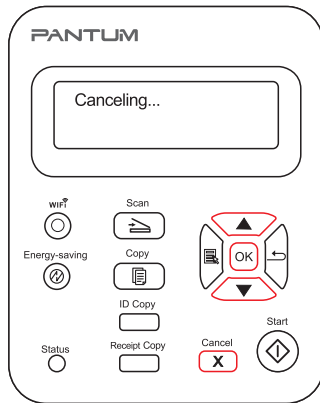

Scan

10

Chapter

10. Scan	2
10.1. Push Scan	2
10.1.1. Single Page Scan	2
10.1.2. Merge Scan.....	3
10.1.3. Other Scan Functions	4
10.2. Pull Scan.....	8
10.2.1. Pantum Scan Application	8
10.2.2. TWAIN Scan Driver	9
10.2.3. WIA Scan Driver.....	11
10.2.4. Cancel Scan Job.....	14
10.3. Mac System Scan.....	15
10.3.1. ICA Scan	15
10.3.2. TWAIN Scan.....	18

10. Scan

This printer provides two types of scan: "Push Scan", which means scanning through the printer's Control Panel operations; "Pull Scan" which means scanning through PC terminal scanning the application.

10.1. Push Scan

This section introduces how to scan documents to the PC (only through USB cable connection) with control panel of the printer. The specific operation steps are as follows:

1) Put the document face down on the glass platen.

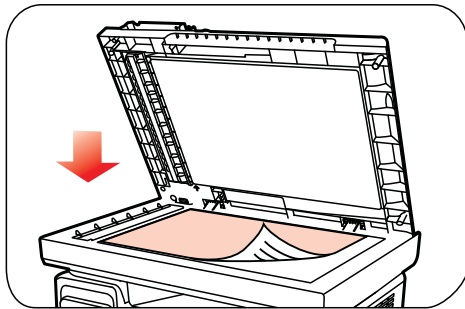

 **Note:** • During copying, please do not open the cover to avoid any adverse impact on the image quality.

- For the information on "Steps of Using Paper and Manuscript", please refer to Chapter 2.5.

2) Press Scan on the Control Panel and press direction pad "▲" or "▼" to select "Single Page Scan" or "Merge Scan" to enter into the Scan mode.

 **Note:** • For the information on "Single Page Scan" and "Merge Scan", please refer to 10.1.1. and 10.1.2.

3) Press "Start" button to start scanning.

 **Note:** • Formats of scanned attachments: network scan supports PDF, TIFF and JPEG formats. Users can select the Save As Type on the panel for the scanned documents.

10.1.1. Single Page Scan

The default scan mode of control panel is Single Page Scan mode.

For the specific steps of scan operation, please refer to Chapter10.1.

10.1.2. Merge Scan

When you want to merge multi-page scanned documents into one PDF, please use Merge Scan function.



-
- Note:**
- The Merge Scan allow the document to be scanned into the PDF format by default.
 - This printer can perform Merge Scan operation only on the control panel.
-

The specific operations are as follows:

1. Press "Scan" button to enter scan status. The default scan mode of control panel is Single Page.

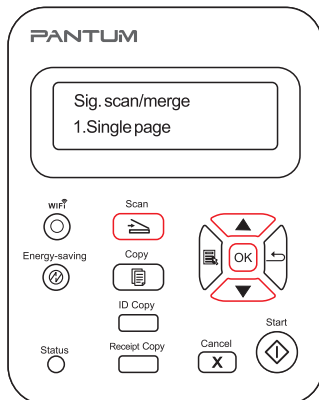

2. Press "▲" or "▼" button to select and enter "Merge Scan" mode.

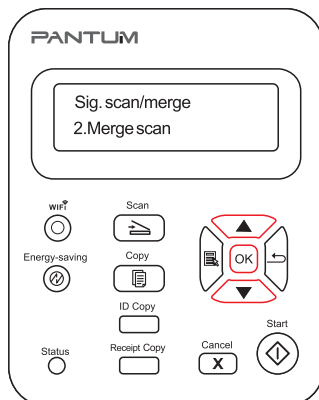

3. Press "Start" button and the Scan Process Bar Interface will pop up on the computer.
4. After completing scanning the first page, the contents as shown below will appear on the control panel:

Press "Start" button - scan the next page

Press "OK" button- end the scanning

5. Put the document to be scanned on the glass platen and you press "Start" button to continue to scan the second page.
6. Repeat the operation as described in the step 5 to scan multi-pages till you press "OK" button to end this operation.
7. After completing the operation, the application will save PDF document to the specified folder.

10.1.3. Other Scan Functions

1. Scan to E-mail

Users can scan monochrome or color documents as attachments to E-mail application. Operation steps as follows:

- ① Type the IP address in the Web browser's address bar to access the embedded Web server of the printer.
- ② Click on "Setting"—"SMTP" to set the relative parameters of the SMTP Protocol; After finishing setting, click on "Apply" to save.

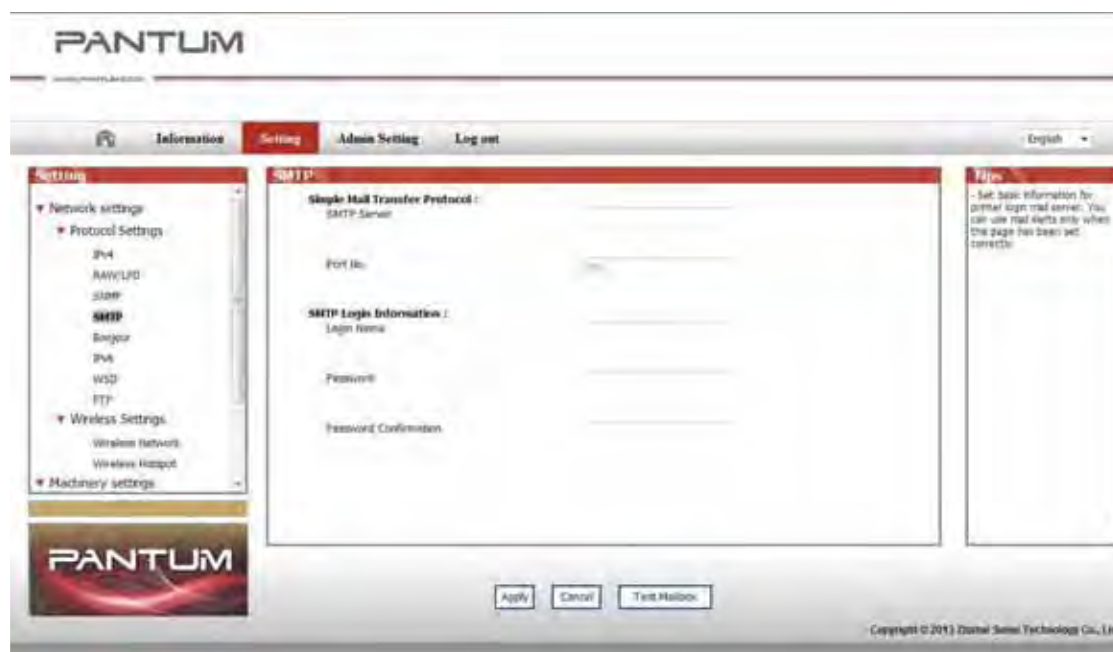

- ③ Click on "E-mail Address Book" in the left setting column to enter into the settings interface of the email.

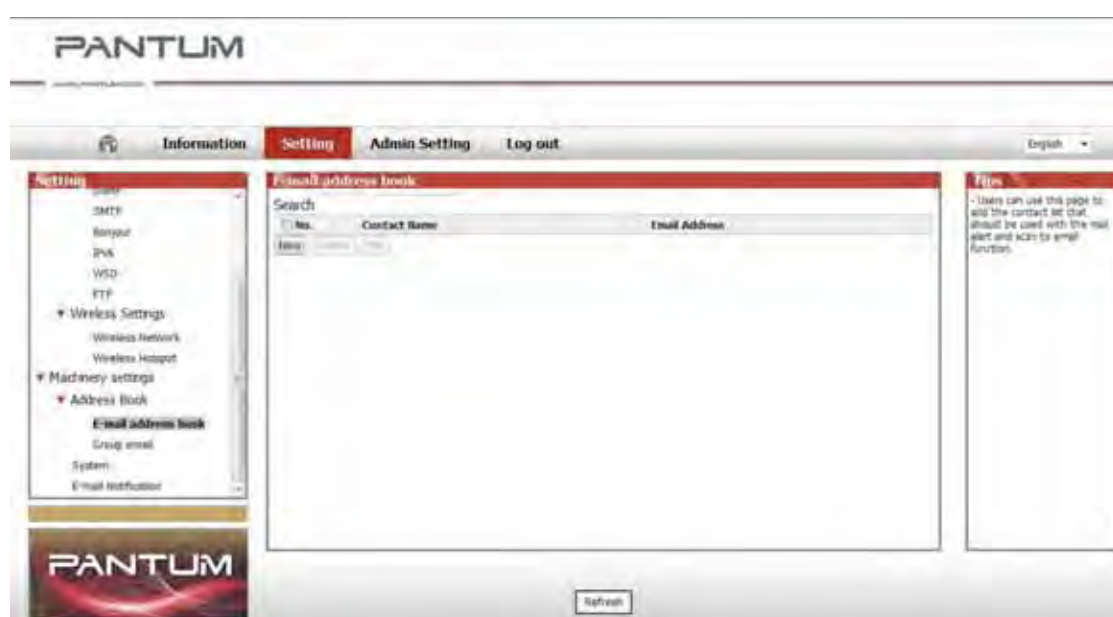

④ Click on "New" and the following window will pop up, edit the name of contacts ,input the E-mail address and then click on "Submit".

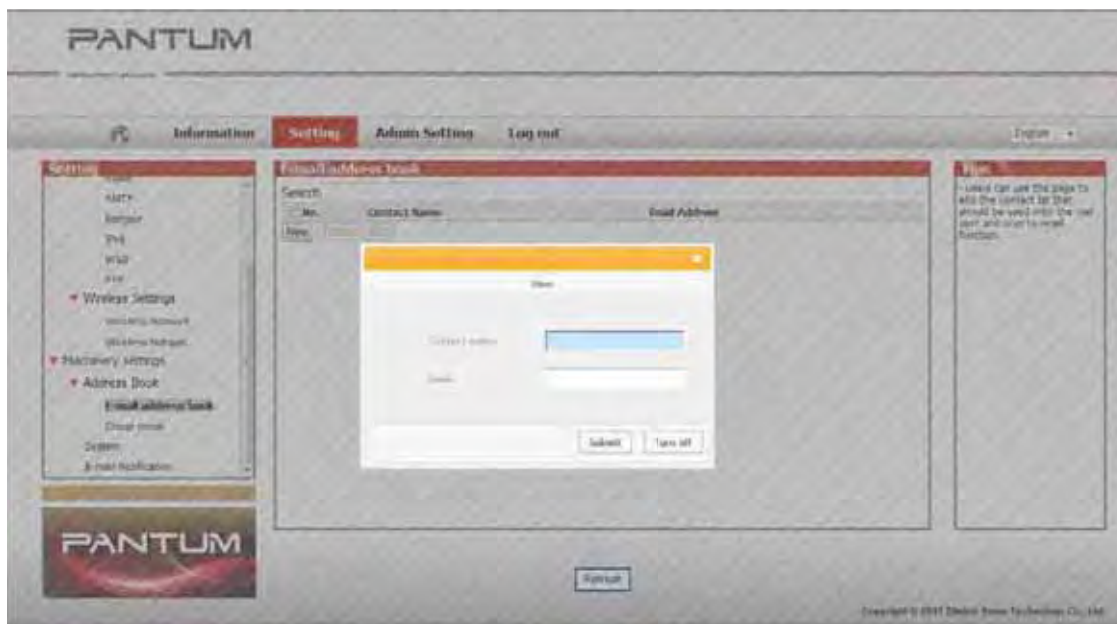

⑤ Put the document on the platen.

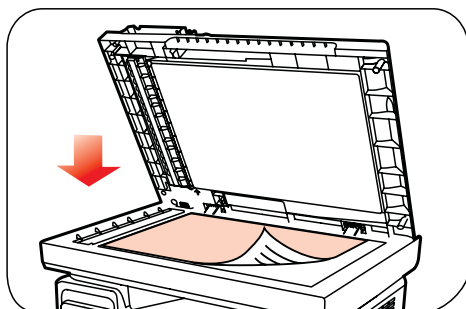

⑥ Press "Scan" button on the control panel, and press "▲" or "▼" to select "1. Single Page Scan" or "2. Merge Scan", then press "OK" button.

⑦ In the "1. Scan To" interface, press "OK" button.

⑧ Press "▲" or "▼" to select "Scan to E-mail" and press "OK" button.

⑨ Press "▲" or "▼" to select "E-mail Address Book" or "Group Mail" and press "OK" button.

⑩ Press "▲" or "▼" to select address or group and then press "OK" button; press "Start" button to start scan.

Please follow these instructions on the settings for group emails.

Set the group name for group e-mail sending by webpage, and set the members, i.e.the receivers, in the group of group email. After finishing scanning, firmware will send the scanned documents to the mail server. Then mail server sends the documents to every member of the group.

2. Scan to FTP

Scanning to FTP requires a network environment. Users can scan comparatively large files online. Users need to log in FTP server with user name and password and install IIS Component on the computer.

1) Operation Steps:

① Type the IP address in the web browser's address bar to access the embedded web server of the printer.

② Click on Setting FTP to enter into FTP Setting interface.

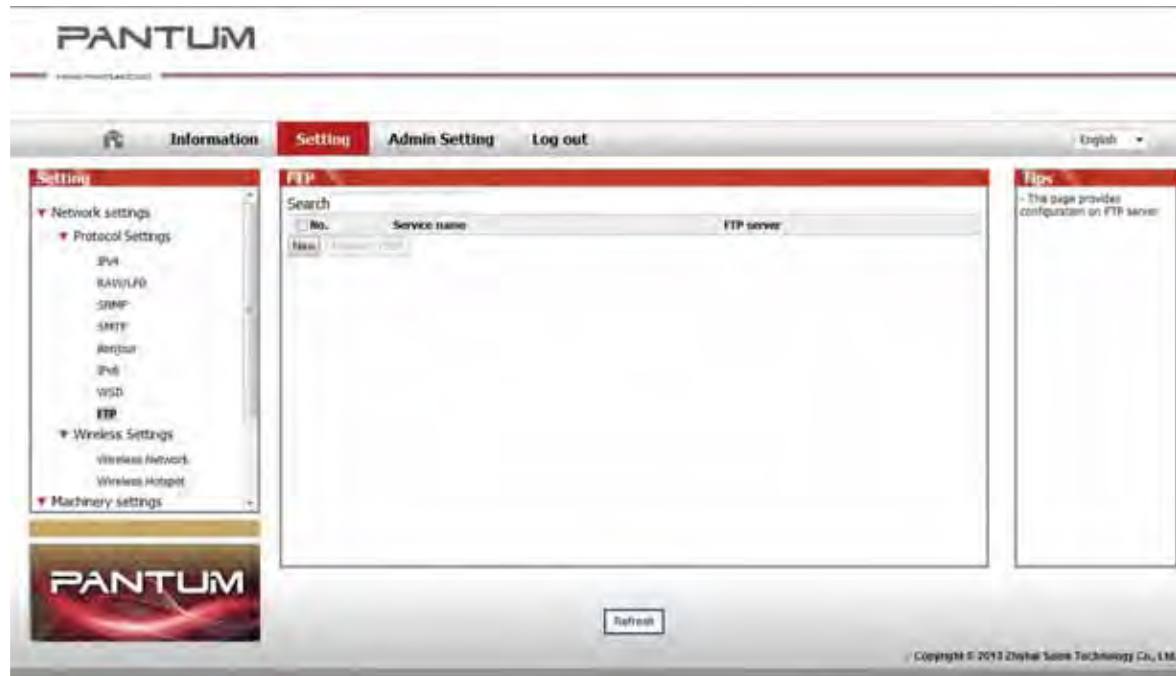

③ Click New, the following window will pop up. Set the relative parameters of the FTP Protocol. After complete setting, click on Submit.

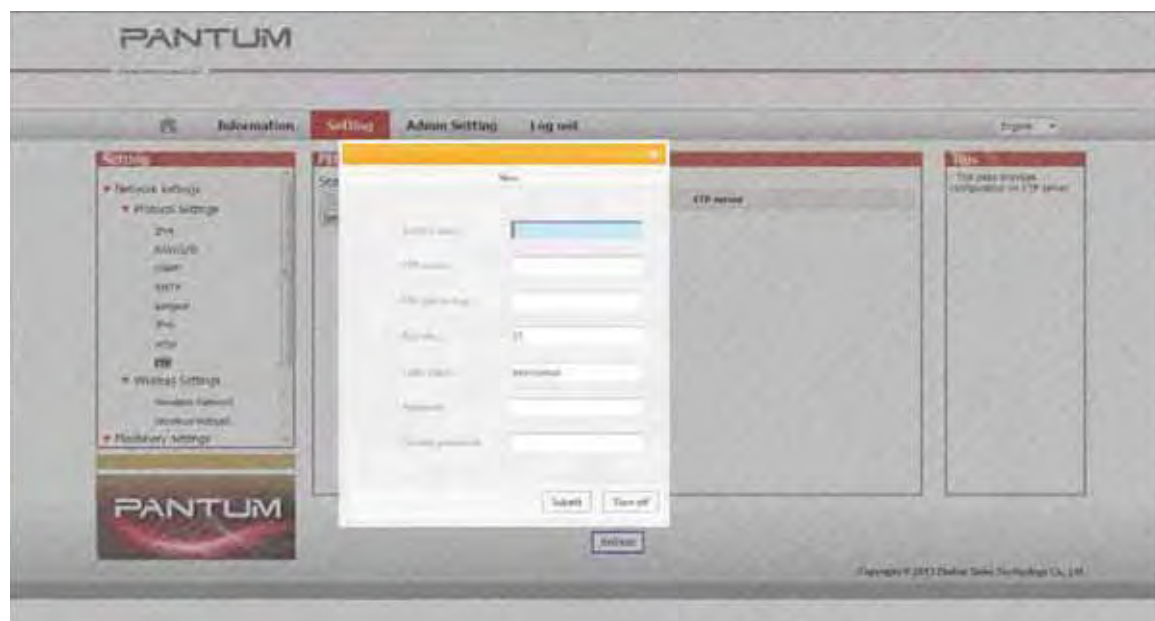

- ④ Put the document on the platen.

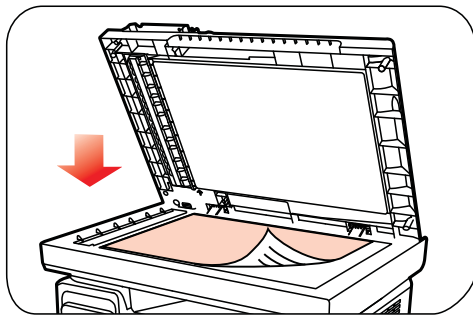

- ⑤ Press "Scan" button on the control panel, press "▲" or "▼" to select "1. Single Page Scan" or "2. Merge Scan" and press "OK" button.
- ⑥ In the "1. Scan To" interface, press "OK" button.
- ⑦ Press "▲" or "▼" to select "Scan to FTP" and press "OK" button.
- ⑧ Press "▲" or "▼" to select the server and press "OK" button; Press "Start" button to start scan.



Note: The relative parameters setting of the FTP Protocol are as follows:

FTP Server: IP Address of the server (such as 10.10.145.100)

Port Number: Default port number is 21

Login Name: For example, anonymous

Password: such as (anonymous login needs no password)

Confirm Password: For example (anonymous login needs no password)

Server Name: For example, PANTUM

10.2. Pull Scan

10.2.1. Pantum Scan Application

Operation Steps:

1) Double click on "Pantum Scan Application" on the computer, the icon is shown as below:



2) The prompt window is shown as below:

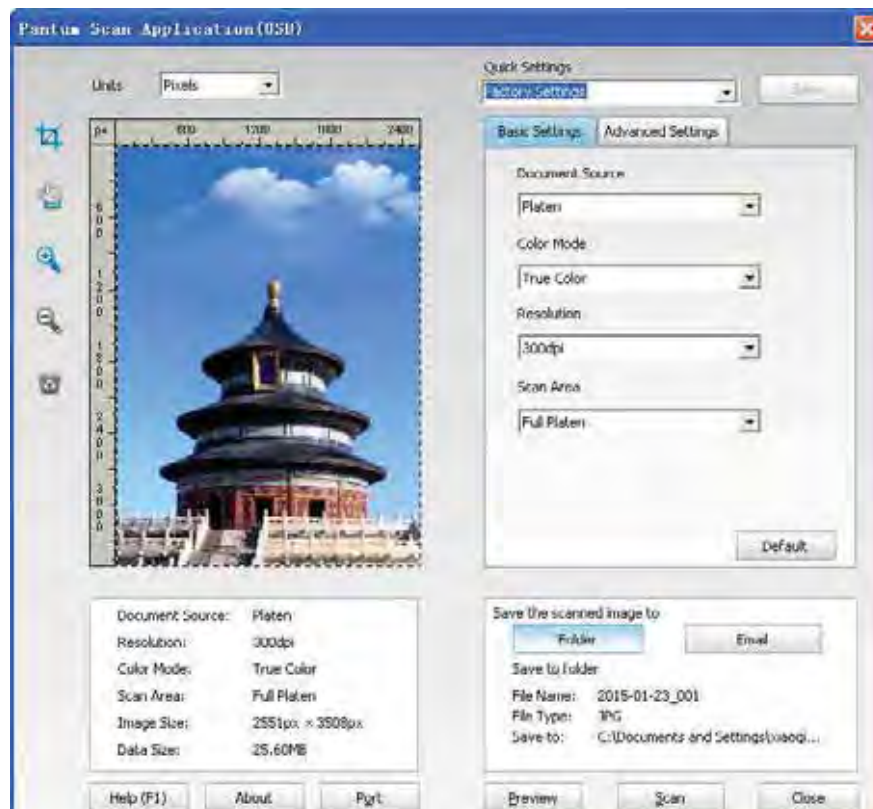

3) Set Scan in the right list. Click "Scan" on the bottom right corner and start scan.

This product complies with the TWAIN and Windows Image Application (WIA) standard. If using the application which supports TWAIN and WIA standard, users can use the scan function and directly scan the images to the open application. The handbook requires Office Software (Word and Excel) and Photoshop, for example, to show the operation.

10.2.2. TWAIN Scan Driver

10.2.2.1. Office Software (Word and Excel)

Operation Steps:

1) Keyboard shortcuts: Alt+I+P+S to open the application's window.



2) Click on "Device" option and select TWAIN Scan, click the "Custom Insert" button below.



3) After the window pops up, set the scan information in the right list of "Basic Setting" and "Advanced Setting". Click on "Scan" and start scan.



Windows Scanner

10.2.3.1. WIA1.0 Scan (Windows XP / Windows Server 2003)

1. Office Software (Word and Excel)

Operation Steps:

1) Keyboard shortcuts: Alt + P + S to open the application's window.



) Click on Device and select I Scan, click the Custom Insert below.



) The prompt window as is shown below, set the scan information.



) Click on the Adjust the Scanned Image quality on the bottom left corner of the above picture, the advanced properties interface will pop up, then users can set the scan; After finishing the settings, click on the OK button, then Scan button to start scan.

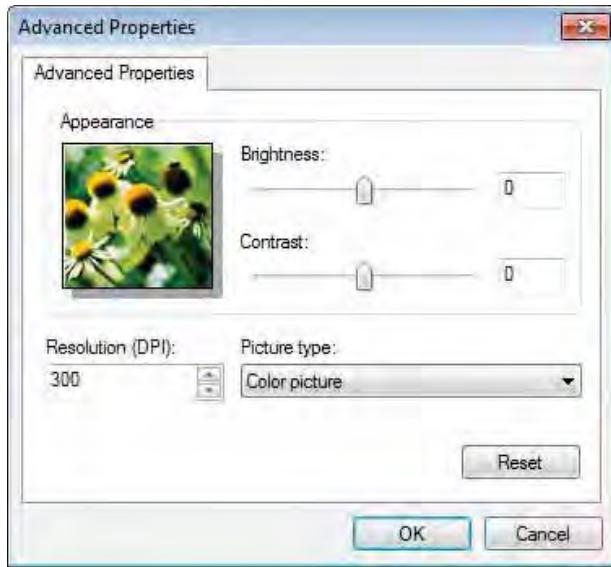

.Photoshop

operation Steps:

1) Launch Photoshop, click File - Import on the top left corner and select Import Scan, as is shown below:



2) After the window pops up, please refer to Step 3 and Step 4 of 10.2.3.1. to see the specific operation steps.

10.2.3.2. WIA 2.0 Scan (Windows Vista / Windows Server 2008 and later versions)

Operation Steps:

1) Click on "Start"- "All Programs"- "Device and Printer" on the left bottom of the desktop.



2) After the window pops up, select the needed printer, and right-click .



) Click on **Start Scan** in the above option bar.



) After the window pops up, set the scan and click **Scan** on the bottom right corner and start scan.

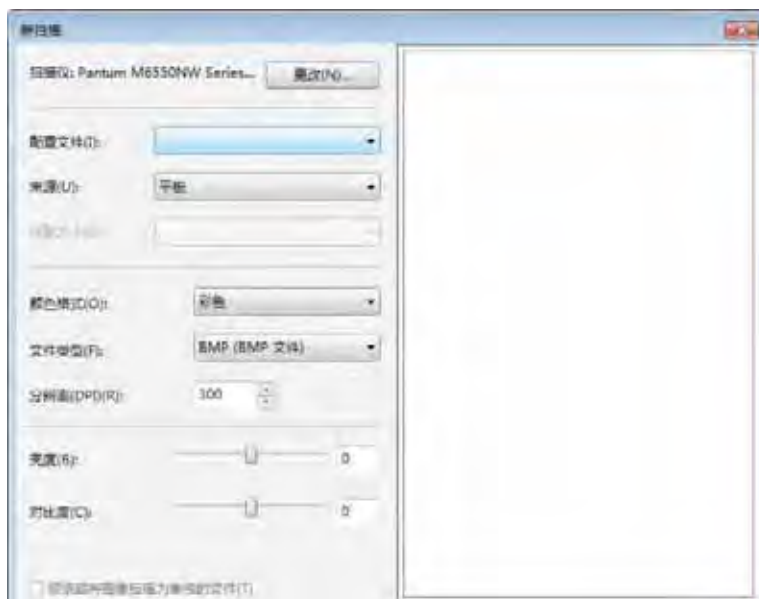

Cancel Scan

During the scanning, two ways are available to cancel the job:

1) Press **Cancel** button on the control panel to cancel the job.

) Click **Cancel** button on the scan progress bar interface of the computer to cancel the job.

ac System Scan

Scan

10.3.1.1. Open ICA via "Print and Scan"

peration Steps:

1. After installing the printer driver, click System Preferences icon on the bottom left corner of the computer desktop.



. After the window pops up, click on Print and Scan .



. After the window pops up, click on Scan .



. Click on **Open Scanner** and the scan window will pop up.



. Click on **Show details** on the bottom right corner to set the scan parameters.



. Click on **Scan** on the bottom right corner and start scan.

all t roug a lications

peration Steps:

1) Click on Finder icon on the bottom left corner of the computer desktop, or use keyboard shortcuts command shift C to open the window. Find Image Capture in plications (or conduct keyboard shortcuts command shift to directly switch to plications) and click to launch the application.



) fter selecting the printer in the left list, set the scan parameters in the right list. Click on Scan on the bottom right corner and start scan.

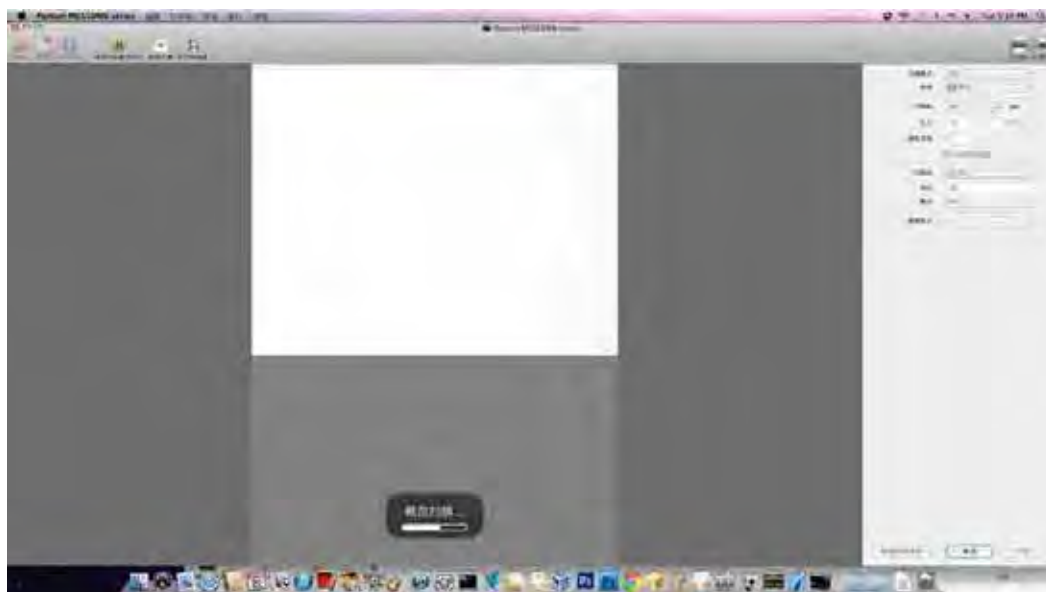

W Scan

Take Photoshop as an example.

operation Steps:

1) Launch Photoshop, click on File Import on the top left corner and select TWAIN Scan, as is shown below:



2) After the window pops up, please refer to Step 3 of 10.2.2.1. to see the specific operation steps.

Routine Maintenance

11

Chapter

11. Routine Maintenance.....	2
11.1. Cleaning the Printer	2
11.2. Maintenance of Laser Toner Cartridge.....	5
11.2.1. Use and Maintenance of Laser Toner Cartridge.....	5
11.2.2. Service Life of the Laser Toner Cartridge.....	5
11.2.3. Replace Laser Toner Cartridge	5

Routine Maintenance

Cleaning the Printer



Note: • Please use mild detergents.

Please clean the printer in accordance with the following steps:

1. Turn off the main power switch and unplug the power cord and USB cable.

Series

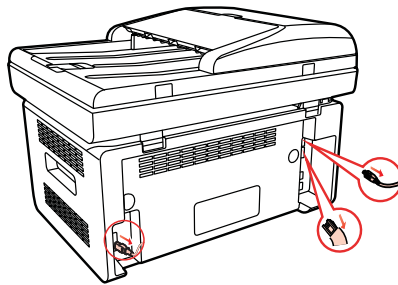

1. Use a soft cloth to wipe the outside of the printer and remove the dust.

Series

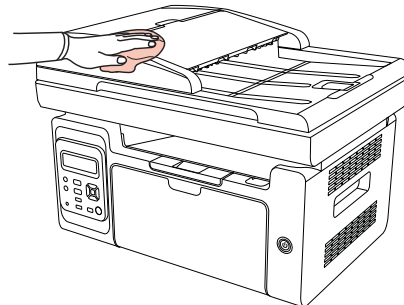

2. Raise the cover and gently wipe the platen glass with a soft cloth.

Series

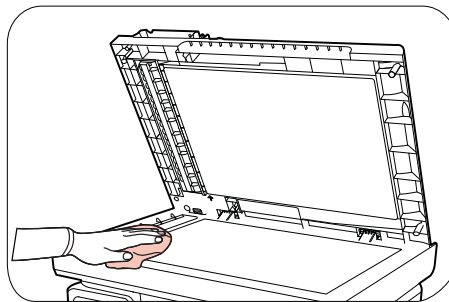

. Raise the scanning platform until it is locked.

Series

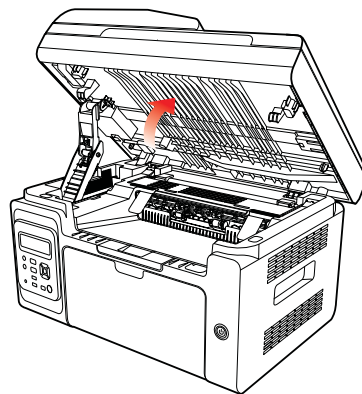

. Open the output bin by the upper right ridge of the concave section.

Series

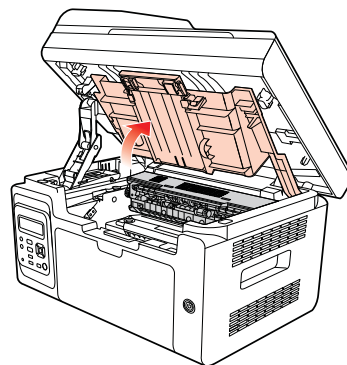

. Remove the laser toner cartridge along the guides.

Series

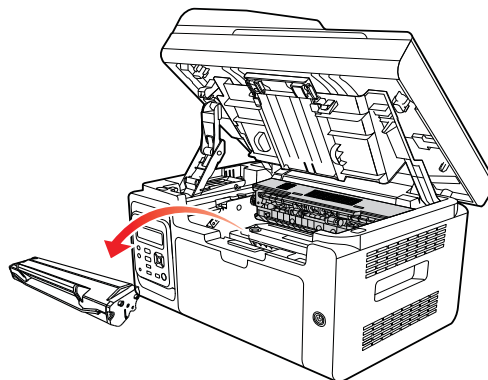

Warning

Some parts of the printer are still hot within a short time after use. When opening the front cover or rear cover to clean the parts inside the printer, please do not touch the parts in the shaded area as shown in the following picture, so as to avoid burns.

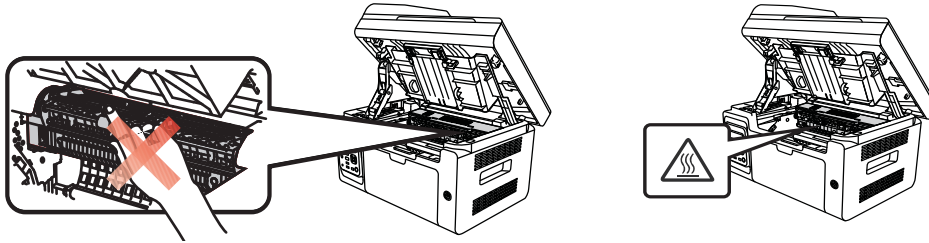

Note: • When removing the laser toner cartridge, put the cartridge in a protective bag or wrap it with thick paper to avoid direct light damaging the photosensitive drum.

• Gently wipe the dustproof mirror of laser scanning surface with a cotton swab or a dry and lint-free soft cloth with a little alcohol.

Series

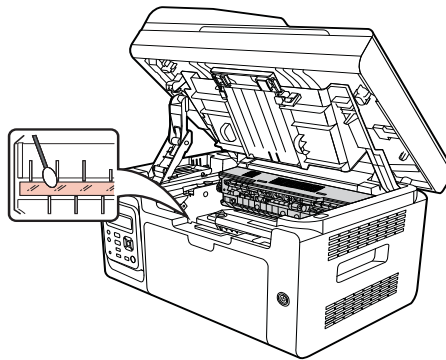

• Clean the inside of the printer by using a dry and lint-free cloth to gently wipe the shaded area as shown in the picture below.

Series

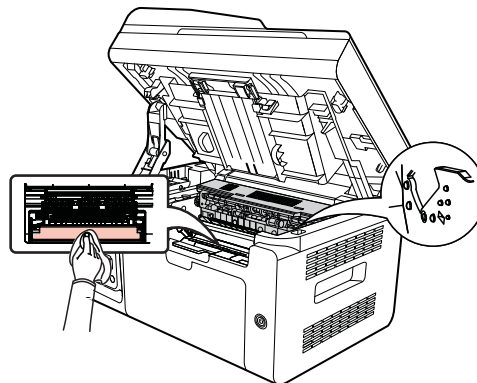

Maintenance of Laser Toner Cartridge

Use and Maintenance of Laser Toner Cartridge

For better print quality, please use the original Pantum laser toner cartridge.



Note: when using the laser toner cartridge, please pay attention to the following:

- Unless used immediately, otherwise, do not remove the laser toner cartridge from the package.
- Do not refill the laser toner cartridge without authorization. Otherwise, the resulting damage is not included in the printer warranty.
- Please store the laser toner cartridge under a cool and dry environment.
- Toner inside the laser toner cartridge is combustible. Please do not put the laser toner cartridge near any source of ignition, so as to avoid causing a fire.
- When removing or disassembling the laser toner cartridge, please pay attention to the toner leakage problem. In case of the toner leakage resulting in that the toner contacts with your skin or splashes into your eyes and mouth, please immediately wash with clear water, and consult a doctor immediately if you feel unwell.
- When placing the laser toner cartridge, please keep it away from the area reachable by children.

Service Life of the Laser Toner Cartridge

Service life of the laser toner cartridge depends on the amount of toner that print jobs require.

When the LCD screen prompts that the toner is exhausted, it indicates that the cartridge life is expiring or has expired. To ensure the print quality, please timely replace with new laser cartridge.

Replace Laser Toner Cartridge



Note: Before replacing the laser toner cartridge, please pay attention to the following:

- The laser toner cartridge surface may contain toner. Please remove it carefully to avoid spilling.
- Put the removed laser toner cartridge on a piece of paper to avoid the toner from accidentally spilling.
- After removing the protective cover, please immediately install the laser toner cartridge into the printer, so as to avoid photosensitive drum damage caused by exposing to too much direct sunlight or indoor light.
- While installing the laser toner cartridge, do not touch the surface of the photosensitive drum so as not to scratch it.

Replacement steps are as follows:

1. Turn off the printer and raise the scanning platform until it is locked.

Series

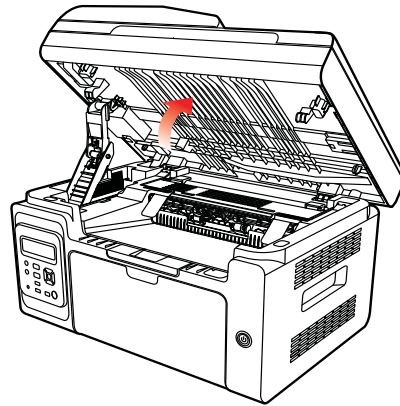

-
2. Open the output bin by the upper right ridge of the concave section.
-

Series

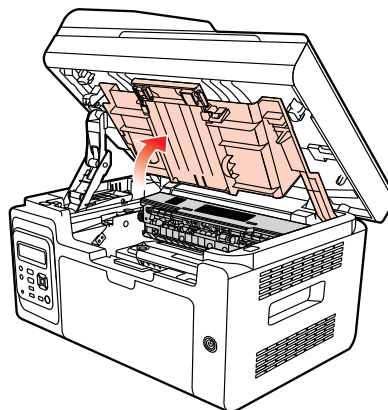

-
3. Remove the exhausted cartridge along the guides.
-

Series

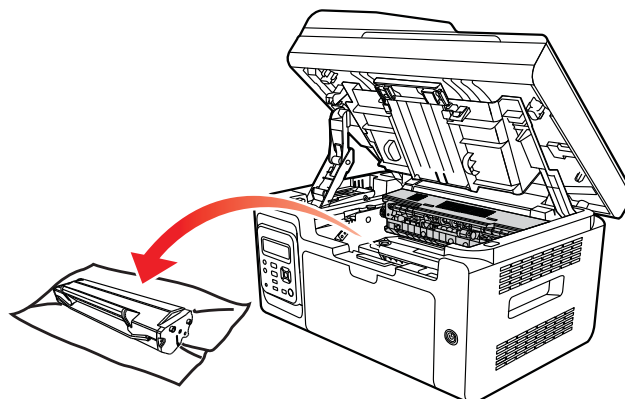

. Open the package of a new laser toner cartridge, hold the handle of the cartridge and gently shake around 10 times, so as to make the toner evenly distributed inside the cartridge.

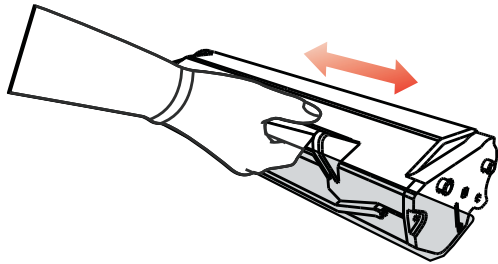

. Remove the cartridge protector (blister cover), insert the cartridge along the guides into the printer, then push it firmly along the direction of the arrow until you hear a "click" assuring you that the cartridge is fully inserted.

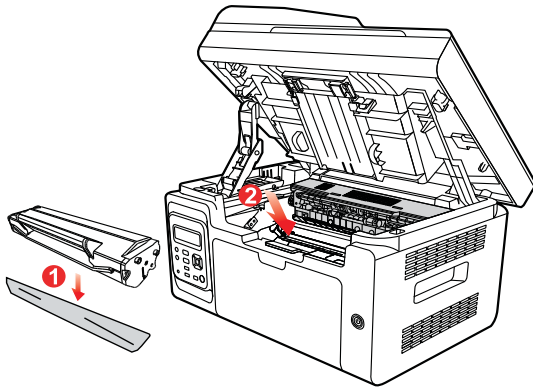

Note: • Check whether there is any seal before installing the laser toner cartridge into the printer. If there is any, please tear off the seal and then install the cartridge.

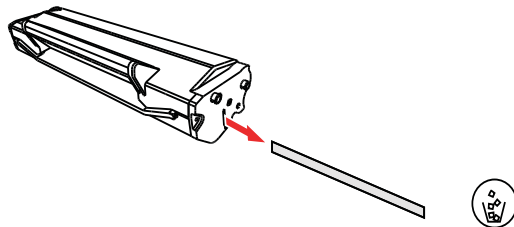

. Cover the output bin and close the scanning platform.

Series

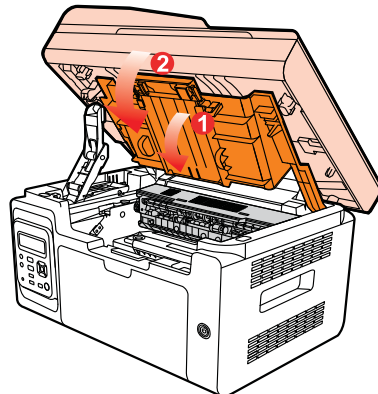

. Restart the printer, and use the product control panel to print a test page.

Troubleshooting

12

Chapter

12. Troubleshooting	2
12.1. Clearing Jammed Paper	2
12.2. Error Message	5
12.3. Common Troubleshooting.....	6
12.3.1. Common Trouble	6
12.3.2. Image Defects	8

12. Troubleshooting

Please read this section carefully. It can help you solve common malfunctions in the printing process. If the problems appeared cannot be solved, please timely contact Pantum Aftersales Service Center.

Prior to handling common trouble, first check that:

- Whether the power cord is connected correctly and the printer is powered on.
- Whether all protective parts are removed.
- Whether the laser toner cartridge is correctly installed.
- Whether the output bin is fully closed.
- Whether the paper is correctly loaded into the tray.
- Whether the interface cable is correctly connected between the printer and the computer.
- Whether the correct printer driver is selected and installed properly.
- Whether the computer port is properly configured and is connected to the proper printer port.

12.1. Clearing Jammed Paper



Note: •Remove the jammed paper in accordance with the following steps, close the upper cover and tidy the paper in the tray, then the printer will automatically resume printing. If the printer cannot automatically start printing, please press the button on the control panel.

If the printer still does not start printing, please check whether all the jammed paper inside the printer are cleared.

If you can not remove the jammed paper yourself, please contact your local Pantum Authorized Repair Center or send the printer to the nearest Pantum Authorized Service Center for repair.

Please follow the following steps to clear the jammed paper if you are prompted of a paper jam by the C .

1) Raise the scanning platform until it is locked.

Series

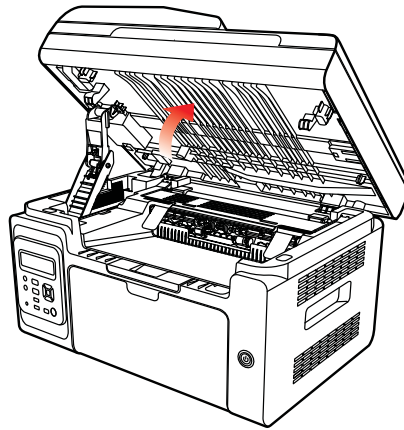

) Open the output bin by the upper right ridge of the concave section.

Series

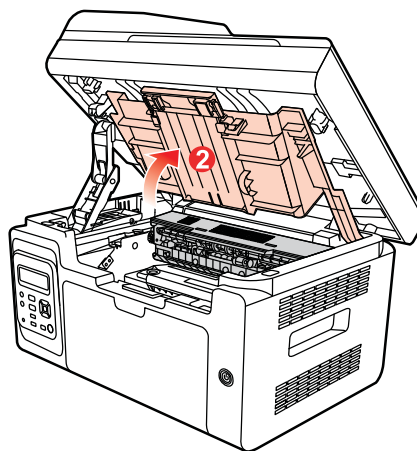

) Remove the laser toner cartridge along the guides.

Series

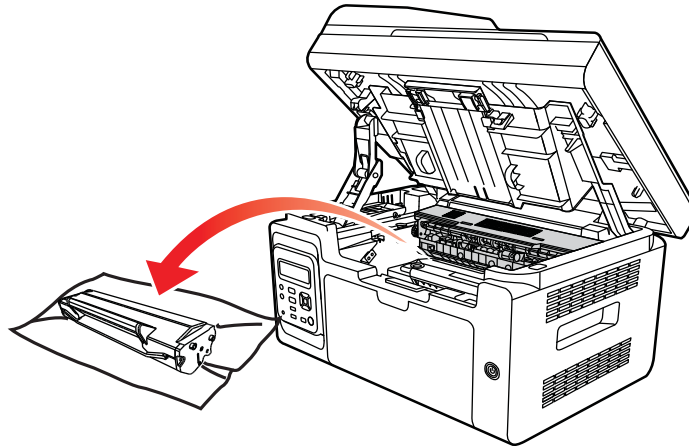

) Fully draw the jammed paper out along the paper output direction.

Series

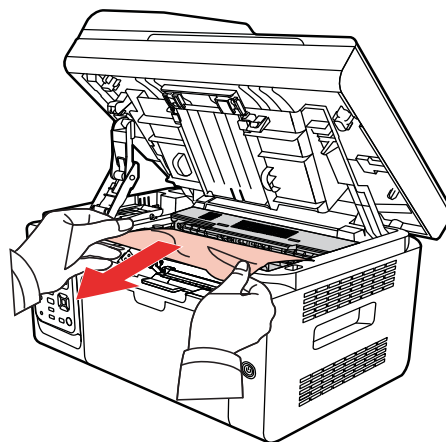

) After removing the jammed paper, insert the laser toner cartridge into the printer along the guides until you hear a click assuring you that the cartridge is fully inserted.

Series

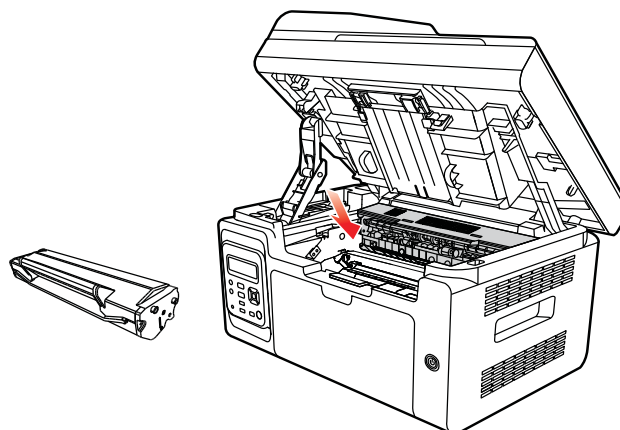

) eately put the paper in the tray , and do not carry out the ne t print until the indicator light resumes print-ready status.

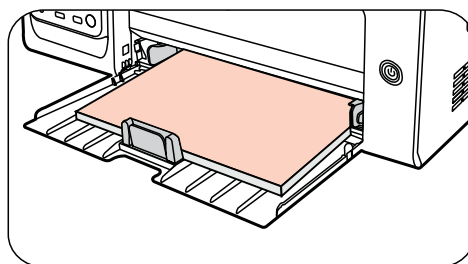

) If you can not remove the jammed paper yourself, please contact your local Pantum uthori ed Repair Center or send the printer to the nearest Pantum uthori ed Service Center for repair.

rror essage

rror message	ause	easeure
Close utput Bin	The paper bin is not fully closed.	Close utput Bin.
ow aser Toner Cartridge etected	The laser toner cartridge is installed incorrectly or laser toner cartridge is damaged.	The laser toner cartridge is installed correctly or new laser toner cartridge is replaced.
Toner ow	Cartridge toner is low	Replace ew aser Toner Cartridge
The toner cartridge life has e pired	Cartridge toner is e hausted.	Replace ew aser Toner Cartridge
Feed am	The print paper is loaded incorrectly. The paper is outside of the specification range.	Please correctly load the print paper.
Printer paper am	The print paper is loaded incorrectly.	Please correctly load the print paper.
Scanner is Busy	ith other scan obs.	Please cancel the current scan ob or wait for the completion of other scan obs.
Scan failed	Scanner internal failure.	Please contact Pantum Customer Service.



ote: • If the problem remains, please contact Pantum Customer Service.

12.3. Common Troubleshooting

12.3.1. Common Trouble



Trouble Type	Trouble	Cause	Solution
Problems in printing	Poor print quality	See 12.3.2. Image Defects.	See 12.3.2. Image Defects.
Problems in copying	Failed to copy	The scanner is damaged.	Please contact Pantum Customer Service.
	Copy Image Abnormal	<ul style="list-style-type: none"> • The scanner is dirty or defective. • The laser toner cartridge is dirty or damaged. 	<ul style="list-style-type: none"> • Clean the scanner. • Clean the laser toner cartridge or replace it with a new one.
Printer Problems	The printer does not work	<ul style="list-style-type: none"> • Power cord of the device is not properly connected. • Data cable of the device is not properly connected. • The print driver is installed incorrectly. • The printer selected is not proper for printing. • The LCD screen prompts error messages. 	<ul style="list-style-type: none"> • Ensure proper connection of the power cord. • Ensure proper connection of the data cable. • Properly install the printer driver. • Select the proper printer.
	Online printing does not work	<ul style="list-style-type: none"> • Data cable of the device is not properly connected. • The printer driver is installed incorrectly. • Printer internal failure. 	<ul style="list-style-type: none"> • Ensure proper connection of the data cable. • Reinstall the printer driver.
	Scanning error	<ul style="list-style-type: none"> • Data cable of the device is not properly connected. • The scan driver is installed incorrectly. • The LCD screen prompts error messages. 	<ul style="list-style-type: none"> • Ensure proper connection of the data cable. • Reinstall the scan driver.

Problems in Handling Paper	Paper feed failure	<ul style="list-style-type: none"> • The print media is loaded incorrectly. • The print media is beyond the usage specification range. • The feed roller is dirty. 	<ul style="list-style-type: none"> • Please correctly load the print media. If you use special print media for printing, please print with the manual feeder tray. • Please use the print media within the specification range. • Clean the feed roller.
	Paper Jam	<ul style="list-style-type: none"> • Too much paper in the tray. • The print media is beyond the usage specification range. • There is foreign matter in the feed channel. • The feed roller is dirty. • Internal parts failure. 	<ul style="list-style-type: none"> • Remove excess paper from the tray. If you print on special print media, please use the manual feeder tray. • Make sure to use the paper that meets specifications. • If you print on special print media, please use the manual feeder tray. • Clean the feed channel. • Clean the feed roller.
	Print with multipage fed in	<ul style="list-style-type: none"> • Excessive static electricity on the print media. • The print media is damp or sticks together. • Internal parts failure. 	<ul style="list-style-type: none"> • Re-separate the print media to eliminate some static electricity. It is suggested that you use the recommended print media. • Re-separate the print media or use new print media.

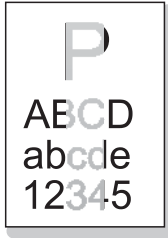
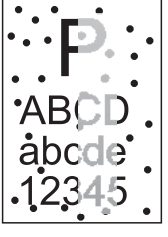
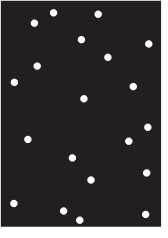

Note: • If the trouble still can not be shooted after the above operations, please contact Pantum Customer Service.

12.3.2. Image Defects

Trouble	Cause	Solution
 <p data-bbox="252 573 528 640">The printout is whitish or light</p>	<ul data-bbox="555 315 1002 651" style="list-style-type: none"> • Toner is low. • The print media does not meet usage specification, such as the media is damp or too rough. • The resolution in the print program is set too low, concentration setting is too low, or toner saving mode is ticked. • The laser toner cartridge is damaged. 	<ul data-bbox="1034 315 1417 551" style="list-style-type: none"> • Please properly use the print media within the specification range. • Set the print resolution, concentration, or cancel ticked toner saving mode in the program.
 <p data-bbox="252 931 400 954">Toner spots</p>	<ul data-bbox="555 685 1002 1122" style="list-style-type: none"> • The laser toner cartridge is dirty or leaks toner. • The laser toner cartridge is damaged. • The print media that does not meet usage specification is used. For example, the media is damp or too rough. • The feed channel is dirty. • If toner spots appear when copying and scanning, the platen glass may be dirty. • The scanner is dirty or damaged. 	<ul data-bbox="1034 685 1417 819" style="list-style-type: none"> • Please use the print media within the specification range. • Clean the feed channel. • Clean the platen glass.
 <p data-bbox="252 1402 400 1424">White spots</p>	<ul data-bbox="555 1155 1002 1491" style="list-style-type: none"> • The print media that does not meet usage specification is used. For example, the media is damp or too rough. • The feed channel is dirty. • The internal part of the laser toner cartridge is damaged. • The reflective glass of the laser inside the printer is dirty. • The scanner is damaged. 	<ul data-bbox="1034 1155 1449 1323" style="list-style-type: none"> • Please use the print media within the specification range. • Clean the feed channel. • Clean the reflective glass of the laser.
 <p data-bbox="252 1783 456 1805">Toner comes off</p>	<ul data-bbox="555 1525 1002 1827" style="list-style-type: none"> • The print media that does not meet usage specification is used. For example, the media is damp or too rough. • The inside of the printer is dirty. • The laser toner cartridge is damaged. • The internal part of the printer is damaged. 	<ul data-bbox="1034 1525 1433 1626" style="list-style-type: none"> • Please use the print media within the specification range. • Clean the inside of the printer.

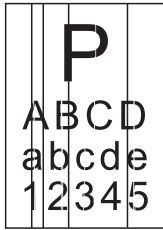

Black vertical stripes

- The laser toner cartridge is dirty.
- The internal part of the laser toner cartridge is damaged.
- The reflective glass of the laser inside the printer is dirty.
- The feed channel is dirty.
- If black vertical stripes appear when copying or scanning, the scanner or the platen glass may be dirty.
- Scanner Light bulb has smudges.
- The scanner is damaged.
- Clean the reflective glass of the laser at the back of the printer.
- Clean the feed channel at the back of the printer.
- Clean the scanner or the platen glass.

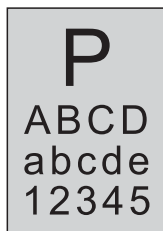

Black background
(gray background)

- The print media that does not meet usage specification is used. For example, the media is damp or too rough.
- The laser toner cartridge is dirty.
- The internal part of the laser toner cartridge is damaged.
- The feed channel is dirty.
- The transfer voltage inside the printer is abnormal.
- Scanning exposure.
- If black background or gray background appears when copying and scanning, the platen glass may be dirty.
- Please use the print media within the specification range.
- Clean the feed channel inside the printer.
- Please close the cover on the manuscript, and then carry out copying and scanning.
- Clean the platen glass.

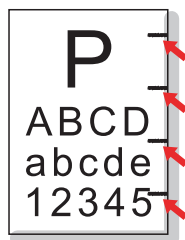

Cyclical traces appear

- The laser toner cartridge is dirty.
- The internal part of the laser toner cartridge is damaged.
- The fuser component is damaged.
- Clean the laser toner cartridge or replace it with a new one.
- Please contact Pantum Customer Service to repair and replace the fuser component.

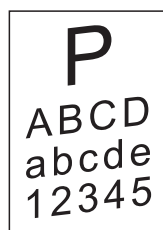

Skewed pages

- The print media is loaded incorrectly.
- The feed channel of the printer is dirty.
- Ensure correct loading the print media.
- Clean the feed channel inside the printer.

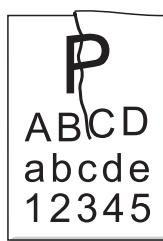

Wrinkled paper

- The print media is loaded incorrectly.
- The print media does not meet the usage specification.
- The feed channel inside the printer is dirty.
- The fuser component of the printer is damaged.
- Ensure correct loading the print media.
- Please use the print media within the specification range for printing.
- Clean the feed channel inside the printer.

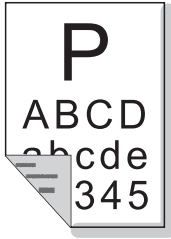

The back of the printout is dirty

- The laser toner cartridge is dirty.
- The transfer roller inside the printer is dirty.
- The transfer voltage inside the printer is abnormal.
- Clean the laser toner cartridge or replace it with a new one.
- Clean the internal transfer components of the printer.

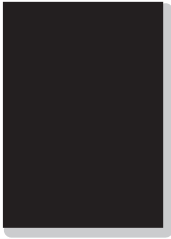

Whole page dark

- The laser toner cartridge is installed incorrectly.
- The internal part of the laser toner cartridge is damaged.
- Abnormal charge inside the printer; the laser toner cartridge is not charged.
- If all-black image appear when copying and scanning, maybe it is scanning exposure, and the cover on the manuscript is not properly closed.
- The scanner is damaged.
- Ensure to install the cartridge correctly.
- Please first close the cover on the manuscript, and then carry out copying and scanning.



The toner does not adhere to the paper

- The print media that does not meet usage specification, such as the media is damp or too rough.
- The inside of the printer is dirty.
- The laser toner cartridge is damaged.
- The internal part of the printer is damaged.
- Please use the print media within the specification range.
- Clean the inside of the printer.

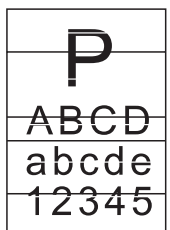

Horizontal stripes

- The laser toner cartridge is incorrectly installed.
- The laser toner cartridge might be damaged.
- The internal part of the printer is damaged.
- Ensure to install the cartridge correctly.



Note: • The above troubles can be handled by cleaning or replacing the laser toner cartridge. If the problem remains, please contact Pantum Customer Service.

Menu Structure

13

Chapter

13. Menu Structure	2
13.1. Copy Settings	2
13.2. Scan Settings.....	4
13.3. System Settings.....	5
13.4. Information Report.....	7
13.5. Version Information.....	7

13. Menu Structure

This chapter mainly introduces the overall menu structure of control panel. The user can know the menu options which can be set by checking the menu structure.





Note: The menu structure in this chapter is the most complete menu structure. Differences might be existed between the menu structure of the mode you actually use with the following menu structure.

13.1. Copy Settings

This product have the following configurations:

General Menu Structure					
First-level Menu	Second-level Menu	Third-level Menu	Fourth-level Menu	Fifth-level Menu	Sixth-level Menu
		1. Image Quality	1. Text + image* 2. Image 3. Text		
		2. Luminosity	1. Manual adjustment* 2. Automatic adjustment		
1. Copy Setting	1. Plain Copy	3. Zoom	1. 1100% 2. 141% A5->A4 3. 122% A5->B5 4. 115% B5->A4 5. 97% LTR->A4 6. 94% A4->LTR 7. 86% A4->B5 8. 81% B5->A5 9. 70% A4->A5 10. Manual adjustment	(25~400%)	
		4. N-in-1	1. Close* 2. 2-in-1 3. 4-in-1 landscape orientation 4. 4-in-1 portrait orientation		

First-level Menu	Second-level Menu	Third-level Menu	Fourth-level Menu	Fifth-level Menu	Sixth-level Menu
			1. Close*		
		5. Clone	2. 2X2		
			3. 3X3		
			4. 4X4		
				1. A4*	
				2. Letter	
				3. B5	
			1. Paper Size	4. A5	
				5. A6	
				6. Executive	
		6. Paper Setting		1. Plain Paper*	
				2. Thick Paper	
				3. Envelope Paper	
			2. Paper Type	4. Film Paper	
				5. Carton Paper	
				6. Label Paper	
				7. Thin paper	
			1. Full page up and down*		
		1. Arrangement Mode	2. Half page up and down		
			3. Half page left and right		
			4. A5 Length		
	2. ID Card Copy		1. Manual adjustment*		
		2. Luminosity	2. Automatic adjustment		
		3. Paper Setting	1. Paper Size	1. A4*	
				2. Letter	

First-level Menu	Second-level Menu	Third-level Menu	Fourth-level Menu	Fifth-level Menu	Sixth-level Menu
		1. Luminosity	1. Manual adjustment*		
			2. Automatic adjustment		
	3. Bill Copy				1. A4*
					2. Letter
		2. Paper Setting	1. Paper Size		3. B5
					4. A5
					5. A6
					6. Executive

13.2. Scan Settings

General Menu Structure					
First-level Menu	Second-level Menu	Third-level Menu	Fourth-level Menu	Fifth-level Menu	Sixth-level Menu
		1. Resolution	1. 75dpi		
			2. 150dpi		
			3. 300dpi*		
			4. 600dpi		
	2. Scan Color	1. Color*			
		2. Monochrome			
		3. Gray			
2. Scan Setting	3. Save Type	1. JPEG			
		2. TIFF			
		3. PDF*			
	4. Scan Scope	1. Full Platen*			
		2. A4			
		3. A5			
		4. B5			
		5. Letter			

13.3. System Settings

General Menu Structure						
First-level Menu	Second-level Menu	Third-level Menu	Fourth-level Menu	Fifth-level Menu	Sixth-level Menu	
3. System Setting	1. Toner Save Setting	1. Close*				
		2. Open				
	2. Language Setting	1. 中文 *				
		2. English				
		3. Italiano				
		4. русский				
		5. Français				
		6. Español				
		7. 繁體中文				
		8. 日本語				
	3. Restore to Factory Setting	1. Yes				
		2. No*				
	4. Sleep Time Setting	1. 1min*				
		2. 5min				
		3. 15min				
4. 30min						
5. 60min						
5. Network setting	1. Wired Network setting		1. IPv4	1. Auto*		
			2. IPv6	2. Manual		
	2. Wireless Network setting		WPS PIN Mode		1. Close	
					2. Open*	
			Connecting WPS...		The WPS connection succeed/WPS connection	
			WPS PIN: xxxxxxxx			

First-level Menu	Second-level Menu	Third-level Menu	Fourth-level Menu	Fifth-level Menu	Sixth-level Menu
			1. IP Address	000.000.000.000	
		1. TCP/IPP	2. Subnet Mask	000.000.000.000	
			3. Gateway	000.000.000.000	
	6. Network Information		1. MAC Address	xx-xx-xx-xx-xx-xx	
			2. Wi-Fi Status	Connected/ No Wi-Fi Signal	
		2. Wi-Fi Information	3. Wi-Fi Channel	xx/No Wi-Fi Signal	
			4. SSID Information	Displays Connected AP Display / No Wi-Fi Signal	

13.4. Information Report

General Menu Structure					
First-level Menu	Second-level Menu	Third-level Menu	Fourth-level Menu	Fifth-level Menu	Sixth-level Menu
4. Information Report	1. Print Demo Page				
	2. Print Information Page				
	3. Print Menu Structure				
	4. Print Menu Setting				
	5. Print Network Configuration				
	6. Print Network Service				
	7. Print Email Address				
	8. Print Group Email				
	9. Print FTP Address				
	10. Print Wi-Fi Hotspot				
	11. Print Wi-Fi Configuration				

13.5. Version Information

General Menu Structure					
First-level Menu	Second-level Menu	Third-level Menu	Fourth-level Menu	Fifth-level Menu	Sixth-level Menu
5. Version Information	1. Panel Firmware Version	x.x.x.x			
	2. Data Firmware Version	x.x.x.x			
	3. Engine Firmware Version	x.x.x.x			

Product Specifications

14

Chapter

14. Product Specifications 2

Product Specifications



- Note:**
- Specification values vary slightly from printers with different models with different functions, and product specifications vary from different countries and regions.
 - These values are based on the initial data. For more information about the latest specifications, please visit: www.pantum.com.

Overview of the Specifications

Product Size ()	417mm*305mm*301mm
Product Weight	9.5kg (No wrappage, but random cartridges)
Print Environment	Preferred Temperature Range for Printing: 10-32°C (50°F-90°F)
	Preferred Moisture Range for Printing: 20% - 80%
Power Voltage	110V Model:
	AC100~127V (±10%); 50Hz/60Hz; 6A
	220V Model:
	AC220~240V (-15%,+10%), 50Hz/60Hz; 3A
Noise	Print: ≤54dB
	Standby: ≤30dB
Power Consumption	Print: Average 370W, Maximum750W
	Networked standby: ≤3.0W
Operating System	Microsoft Windows Server2003/Server2008/Server2012/XP/Vista/Win7/Win8/Win8.1 (32/64 Bit)
	Mac OS 10.6/10.7/10.8/10.9/10.10
	Linux
	IOS/Android
Communication interface	Kylin (Godson)
	Hi-speed USB 2.0
	100Base-Tx Ethernet (Applicable for network model)
	Wi-Fi 802.11b/g/n (Applicable for Wi-Fi model only)
Processor	600MHz
Memory	128MB/256MB

Print Specifications

Print Speed	22ppm (A4)/23ppm (Letter)
Print Time of First Page	<7.8sec
Monthly Maximum Print Copies	20,000 pages
Print Language	GDI

Copy Specifications

Copy Speed	22cpm (A4)/23cpm (Letter)
FCOT	<11sec
Maximum Pages for Successive Print	1-99 Pages
Zoom Ratio	25%~400%
Other Copy Functions	ID copy, Receipt copy, N-up copy, Clone copy

Scan Specifications

Scan Type	Flatbed+ADF(M6550 Series)
Maximum Scan Size	Flatbed: 216×297mm ADF: 216 x 356 mm
Chromoscan	Yes
Scan Output Function	Scan to E-mail, PC, FTP

The Responsible party information in USA:
COMPANY NAME:Magnell Associate,Inc. (DBA NEWEGG.COM)
ADDRESS:17708 Rowland Street City of Industry,CA 91748-1119 USA
TEL:626-271-1420 ext 22651

PANTUM