

# Full HD Video Wireless Kit

Full HD Video Wireless Receiver



Full HD Video Wireless Transmitter



**BV-2222R**  
**BV-2322R**  
**BV-2422R**  
**BV-2522R**  
**BV-2622R**  
**BV-2722R**  
**BV-2822R**  
**BV-1222R**

**BV-2422T**  
**BV-2322T**  
**BV-2222T**

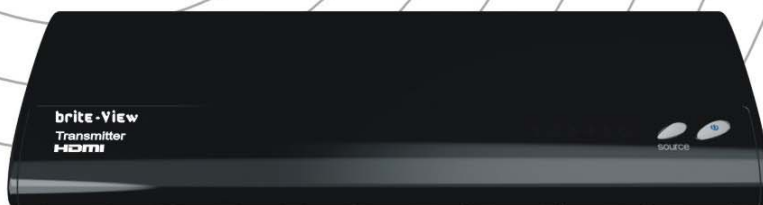

**BV-2822T**  
**BV-2722T**  
**BV-2622T**  
**BV-2522T**

Please read the user manual and the quick installation guide so you can enjoy the product to the full extend.

# Full HD Video Wireless Kit

Full HD Video Wireless Receiver



- ZWD-2222R
- ZWD-2322R
- ZWD-2422R
- ZWD-2522R
- ZWD-2622R
- ZWD-2722R
- ZWD-2822R
- ZWD-1222R

Full HD Video Wireless Transmitter



- ZWD-2422T
- ZWD-2322T
- ZWD-2222T



- ZWD-2822T
- ZWD-2722T
- ZWD-2622T
- ZWD-2522T

Please read the user manual and the quick installation guide so you can enjoy the product to the full extend.

# Table of Contents

<b>TABLE OF CONTENTS .....</b>	<b>1</b>
<b>1. IMPORTANT INFORMATION .....</b>	<b>2</b>
<b>SAFETY PRECAUTIONS .....</b>	<b>2</b>
<b>DANGER: BE CAREFUL WITH ELECTRICITY. ....</b>	<b>2</b>
<b>2. INTRODUCTION .....</b>	<b>3</b>
<b>2.1 PACKING CONTENT .....</b>	<b>3</b>
<b>2.2 OVERVIEW .....</b>	<b>4</b>
<b>3. INSTALLATION.....</b>	<b>10</b>
<b>4. TROUBLESHOOTING .....</b>	<b>21</b>
<b>5. SUPPORTED RESOLUTION.....</b>	<b>23</b>
<b>6. AUDIO BIT RATE SUPPORT .....</b>	<b>24</b>
<b>7. PRODUCT SPECIFICATION .....</b>	<b>25</b>

# 1. Important Information

Please take the time to read this user manual before using the ZWD-2422T and ZWD-2422R.

It contains important information about operating your Full HD video wireless kit.



Our limited warranty applies when the product is handled properly for intended use, in accordance with its operating instruction. However, the warranty may be void in the following cases:

- Repair, product modification or alteration have been performed by unauthorized service personnel
- Damages caused by accidents, including but not limited to, lightning, water, fire, or moisture
- Use of an AC adapter not compatible with the product and its voltage rating
- The model number on the product has been altered, deleted, removed or made illegible.

such as any AV device connection or TV connection.

- **Power outlet:** To prevent electric shock, make sure to use the appropriate AC adapters as power supply to the transmitter and the receiver.
- **Power cord:** Be sure the power cord is routed so that it will not be stepped on or pinched by heavy items.
- **Power overloading:** Avoid overloading electrical outlets or extension cords which otherwise could result in electric shock or fire.
- **Lightning:** Disconnect the product from the power source if it is left unattended for a long period of time, and to protect the product from lightning.
- Always disconnect the power cord from the power outlet when you are not using your Full HD Video wireless kit. This reduces the risk of electric shocks or fire.

## Safety Precautions

	<b>WARNING!</b>  RISK OF ELECTRICAL SHOCK DO NOT OPEN	
<p><b>WARNING:</b> TO REDUCE THE RISK OF ELECTRICAL SHOCK DO NOT REMOVE THE COVER NO USER-SERVICEABLE PARTS ARE INSIDE REFER SERVICING TO QUALIFIED PERSONNEL</p>		



**Danger:** Be careful with electricity.

- Power to the units must be switched off before any work is undertaken,



## Warning

- This product should not be exposed to dripping or splashing. No object filled with liquids, such as vases, should be placed on the product.
- **Object Entry:** To avoid electric shock, never stick anything in the slots on the case or remove the cover.
- Place receiver/transmitter on a flat, hard and stable surface
- **Ventilation:** Do not block the ventilation slots on the receiver/transmitter or place any heavy object on the top cover. Blocking the air flow could damage the receiver. Arrange components so that air can flow freely around the receiver. Ensure that there is adequate ventilation if the receiver is placed in a stand. Put the receiver/transmitter in a

property ventilated area, away from direct sunlight or any source of heat.

- **Water Exposure:** To reduce the risk of fire or electric shock, do not expose the receiver/transmitter to rain or moisture.
- **This is indoor solution.**
- **Our company has the right to modify this document without any notice.**

#### **DECLARATION OF CONFORMITY**

This device complies with Part 15 of the FCC Rules. Operation is subject to the following two conditions:

- (1) This device may not cause harmful interference, and
- (2) This device must accept any interference received, including interference that may cause undesired operation.

#### **EMI (Electro Magnetic Interference)**

#### **EN 55022 Information technology equipment----**

Radio disturbance characteristics---Limits and methods of measurement

#### **EN 61000-3-2 Electromagnetic compatibility (EMC)---**

Part 3-2:Limits---Limits for harmonic current emissions (equipment input current up to and including 16 A per phase)

#### **EN 61000-3-3 Electromagnetic compatibility (EMC)---**

Part 3:Limits---Section 3: Limitation of voltage changes, voltage fluctuations and flicker in public low-voltage supply systems, for equipment with rated current  $\leq 16$  A per phase and not subject to conditional connection

#### **EN 55024 Information technology equipment----**

Equipment---Immunity characteristics---Limits and methods of measurement

#### **EN 301 489-1**

Electromagnetic compatibility and Radio spectrum Matters (ERM); Electro Magnetic Compatibility (EMC) standard for radio equipment and services; Part 1: Common technical requirements

#### **EN 301 489-17**

Electromagnetic compatibility and Radio spectrum Matters (ERM); Electro magnetic Compatibility(EMC) standard for radio equipment; Part 17: Specific conditions for 2,4 GHz wideband transmission systems, 5GHz high performance RLAN equipment and 5,8 GHz Broadband Transmitting Systems

**EN 60065** Audio , video and similar electronic apparatus—Safety requirements

#### **TRADEMARK INFORMATION**

- HDMI, the HDMI Logo and High-Definition Multimedia Interface are trademarks of HDMI Licensing LLC.

#### **Special Notice**

- Never use this product nearby an aircraft or medical facility. It can cause interference or undesirable effect on the operation result.
- Use of this product in the following locations may result in abnormal video and audio output (noise, blocked image... etc.).
  - Product installed in the walls made of concrete.
  - Product is situated near the refrigerator or metal fitment.
  - A cluttered room where the wireless signals may be blocked
- This product has been tested and manufactured to comply with each country's safety rules. However, there is no guarantee that interference will not occur in some installation scenario. If the interference happens, increase the distance between the transmitter and receiver.
- ZWD-2422 may interfere 5GHz wireless devices, such as routers or other wireless devices. Therefore, if you have an 802.11n router, configure it to the 2.4 GHz band rather than the 5GHz band.
- Optimal range between ZWD-2422 transmitter and receiver is between 2 and 20 meters within line of sight.



## **CAUTION of RF module on US region**

- Any changes or modifications not expressly approved by the grantee of this device could void the user's authority to operate the equipment.
- This equipment must be installed and operated in accordance with provided instructions and the antenna(s) used for this transmitter must be installed to provide a separation distance of at least 20 cm from all persons and must not be co-located or operating in conjunction with any other antenna or transmitter. End-users and installers must be provided with antenna installation instructions and transmitter operating conditions for satisfying RF exposure compliance.
- Outdoor operations in the 5150 ~ 5250MHz, 5600~5650MHz band are prohibited.
- This device has no Ad-hoc capability for 5250~5350MHz and 5470~5725MHz.
- Outdoor operations in the 5470~5725MHz band are prohibited. This device could not be used in the 5600~5650MHz.
- The Device not operation in 5600~5650MHz.
- Industry Canada regulatory information Operation is subject to the following two conditions: (1) this device may not cause interference, and (2) this device must accept any interference, including interference that may cause undesired operation of the device.
- The user is cautioned that this device should be used only as specified within this manual to meet RF exposure requirements. Use of this device in a manner inconsistent with this manual could lead to excessive RF exposure conditions.
- The following statement must be included with all versions of this document supplied to an OEM or integrator, but should not be distributed to the end user.
  - This device is intended for OEM integrators only.
  - Please See the full Grant of

Equipment document for other restrictions.

- This device must be operated and used with a locally approved access point.

- The following regulatory and Safety notices must be published in documentation supplied to the end user of the product or system incorporating an adapter in compliance with local regulations, Host system must be labeled with "Contains FCC ID: XXX-XXXX", FCC ID displayed on label.

## **System Warning**

### FEDERAL COMMUNICATIONS COMMISSION INTERFERENCE STATEMENT

This equipment has been tested and found to comply with the limits for a Class B digital device, pursuant to Part 15 of the FCC Rules. These limits are designed to provide reasonable protection against harmful interference in a residential installation. This equipment generates, uses and can radiate radio frequency energy and, if not installed and used in accordance with the instructions, may cause harmful interference to radio communications. However, there is no guarantee that interference will not occur in a particular installation. If this equipment does cause harmful interference to radio or television reception, which can be determined by turning the equipment off and on, the user is encouraged to try to correct the interference by one or more of the following measures:

- Reorient or relocate the receiving antenna.
- Increase the separation between the equipment and receiver.
- Connect the equipment into an outlet on a circuit different from that to which the receiver is connected.
- Consult the dealer or an experienced radio/TV technician for help.

## **CAUTION of System on US region**



- Any changes or modifications not expressly approved by the grantee of this device could void the user's authority to operate the equipment.
- This equipment must be installed and operated in accordance with provided instructions and the antenna(s) used for this transmitter must be installed to provide a separation distance of at least 20 cm from all persons and must not be co-located or operating in conjunction with any other antenna or transmitter. End-users and installers must be provided with antenna installation instructions and transmitter operating conditions for satisfying RF exposure compliance.
- Outdoor operations in the 5150~5250MHz, 5600~5650MHz band are prohibited.
- This device has no Ad-hoc capability for 5250~5350MHz and 5470~5725MHz.
- Outdoor operations in the 5470~5725MHz band are prohibited. This device could not be used in the 5600~5650MHz.
- The device not operation in 5600~5650MHz.

## **CAUTION of System on Canada region**



- Industry Canada regulatory information Operation is subject to the following two conditions:
  1. This device may not cause interference,
  2. This device must accept any interference, including interference that may cause undesired operation of the device.
- The user is cautioned that this device should be used only as specified within this manual to meet RF exposure requirements. Use of this device in a manner inconsistent with this manual could lead to excessive RF exposure conditions.



## **CAUTION of System on US region**

- Any installation of either a master or a client device within 35 km of a TDWR location shall be separated by at least 30 MHz (center-to-center) from the TDWR operating frequency (as shown in the below table), and
- Procedures for the installers and the operators on how to register the devices in the industry-sponsored database with the appropriate information regarding the location and operation of the device and installer information is included.

A voluntary WISPA sponsored database has been developed that allows operators and installers to register the location information of the UNII devices operating outdoors in the 5470 – 5725 MHz band within 35 km of any TDWR location (see <http://www.spectrumbridge.com/udia/home.aspx>). This database may be used by government agencies in order to expedite resolution of any interference to TDWRs.



STATE	CITY	LONGITUDE	LATITUDE	FREQUENCY	TERRAIN ELEVATION (MSL) [ft]	ANTENNA HEIGHT ABOVE TERRAIN [ft]
AZ	PHOENIX	W 112 09 46	N 33 25 14	5610 MHz	1024	64
CO	DENVER	W 104 31 35	N 39 43 39	5615 MHz	5643	64
FL	FT LAUDERDALE	W 080 20 39	N 26 08 36	5645 MHz	7	113
FL	MIAMI	W 080 29 28	N 25 45 27	5605 MHz	10	113
FL	ORLANDO	W 081 19 33	N 28 20 37	5640 MHz	72	97
FL	TAMPA	W 082 31 04	N 27 51 35	5620 MHz	14	80
FL	WEST PALM BEACH	W 080 16 23	N 26 41 17	5615 MHz	20	113
GA	ATLANTA	W 084 15 44	N 33 38 48	5615 MHz	962	113
IL	MCCOOK	W 087 51 31	N 41 47 50	5615 MHz	646	97
IL	CRESTWOOD	W 087 43 47	N 41 39 05	5645 MHz	663	113
IN	INDIANAPOLIS	W 086 26 08	N 39 38 14	5605 MHz	751	97
KS	WICHITA	W 097 26 13	N 37 30 26	5603 MHz	1270	80
KY	COVINGTON CINCINNATI	W 084 34 48	N 38 53 53	5610 MHz	942	97
KY	LOUISVILLE	W 085 36 38	N 38 02 45	5646 MHz	617	113
LA	NEW ORLEANS	W 090 24 11	N 30 01 18	5645 MHz	2	97
MA	BOSTON	W 070 56 01	N 42 09 30	5610 MHz	151	113
MD	BRANDYWINE	W 076 50 42	N 38 41 43	5635 MHz	233	113
MD	BENFIELD	W 076 37 48	N 39 05 23	5645 MHz	184	113
MD	CLINTON	W 076 57 43	N 38 45 32	5615 MHz	249	97
MI	DETROIT	W 083 30 54	N 42 06 40	5615 MHz	656	113
MN	MINNEAPOLIS	W 092 55 58	N 44 52 17	5610 MHz	1040	80
MO	KANSAS CITY	W 094 44 31	N 39 29 55	5605 MHz	1040	64
MO	SAINT LOUIS	W 090 29 21	N 38 48 20	5610 MHz	551	97
MS	DESOTO COUNTY	W 089 59 33	N 34 53 45	5610 MHz	371	113
NC	CHARLOTTE	W 080 53 06	N 35 20 14	5608 MHz	757	113
NC	RALEIGH DURHAM	W 078 41 50	N 36 00 07	5647 MHz	400	113
NJ	WOODBIDGE	W 074 16 13	N 40 35 37	5620 MHz	19	113
NJ	PENNSAUKEN	W 075 04 12	N 39 56 57	5610 MHz	39	113
NV	LAS VEGAS	W 115 00 26	N 36 08 37	5645 MHz	1995	64
NY	FLOYD BENNETT FIELD	W 073 52 49	N 40 35 20	5647 MHz	8	97
OH	DAYTON	W 084 07 23	N 40 01 19	5640 MHz	922	97
OH	CLEVELAND	W 082 00 28	N 41 17 23	5645 MHz	817	113
OH	COLUMBUS	W 082 42 55	N 40 00 20	5605 MHz	1037	113
OK	AERO. CTR TDWR #1	W 097 37 31	N 35 24 19	5610 MHz	1285	80
OK	AERO. CTR TDWR #2	W 097 37 43	N 35 23 34	5620 MHz	1293	97
OK	TULSA	W 095 49 34	N 36 04 14	5605 MHz	712	113
OK	OKLAHOMA CITY	W 097 30 36	N 35 16 34	5603 MHz	1195	64
PA	HANOVER	W 080 29 10	N 40 30 05	5615 MHz	1266	113
PR	SAN JUAN	W 066 10 46	N 18 28 26	5610 MHz	59	113
TN	NASHVILLE	W 086 39 42	N 35 58 47	5605 MHz	722	97
TX	HOUSTON INTERCNTL	W 095 34 01	N 30 03 54	5605 MHz	154	97
TX	PEARLAND	W 095 14 30	N 29 30 59	5645 MHz	36	80
TX	DALLAS LOVE FIELD	W 096 58 06	N 32 55 33	5608 MHz	541	80
TX	LEWISVILLE DFW	W 096 55 05	N 33 03 53	5640 MHz	554	31
UT	SALT LAKE CITY	W 111 55 47	N 40 58 02	5610 MHz	4219	80
VA	LEESBURG	W 077 31 46	N 39 05 02	5605 MHz	361	113
WI	MILWAUKEE	W 088 02 47	N 42 49 10	5603 MHz	820	113

## 2. Introduction

ZWD-2422T and ZWD-2422R wireless HD audio/video transmission solution allows users to place their HDTV set or projector where you want, free of the constraint of cables. Just connect your HDTV to the ZWD-2422R (receiver) with an HDMI cable, and connect your AV equipment (Blu-ray players, HD set-up boxes, game consoles or HD media players and streamers) to the ZWD-2422T (transmitter). Besides HDTVs, any display with an HDMI input, such as LCD and plasma monitors, are compatible with the ZWD-2422R.

This setup doesn't clutter your media and allows the AV equipment to be hidden in the cabinet behind your seating area. This solution delivers uncompressed 1080p full HD video and audio content to your existing HDTV set wirelessly. It operates the transmission in 4.9 GHz~ 5.9 GHz frequencies and it can adjust its communication frequency automatically in case of interference from another RF system. With built-in Omni-directional antennas, it can transmit uncompressed video content to 20 meters (66 feet) LOS (Line of sight) with no latency.

Both IR Sensor Extender Cable and IR Blaster Extender Cable are included in the package so users can point their remote control of the AV source at the ZWD-2422R directly for device operation.

### **Note:**

**Except North America, The wireless link might require 80 seconds to connect between transmitter and receiver, and show video on the TV screen. Please be patient and wait for a while.**

## 2.1 Packing Content

Please check whether the following items are present in the package. If any items missed or damaged, please call your dealer.

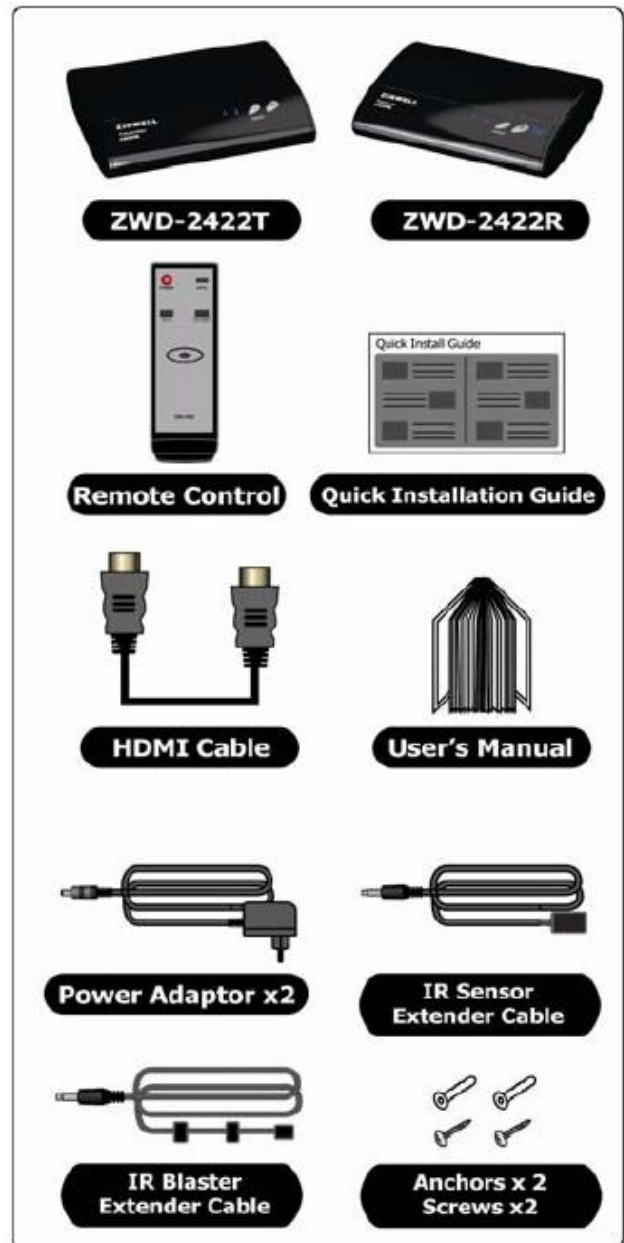

## 2.2 Overview

### A. ZWD-2422T: Full HD Transmitter

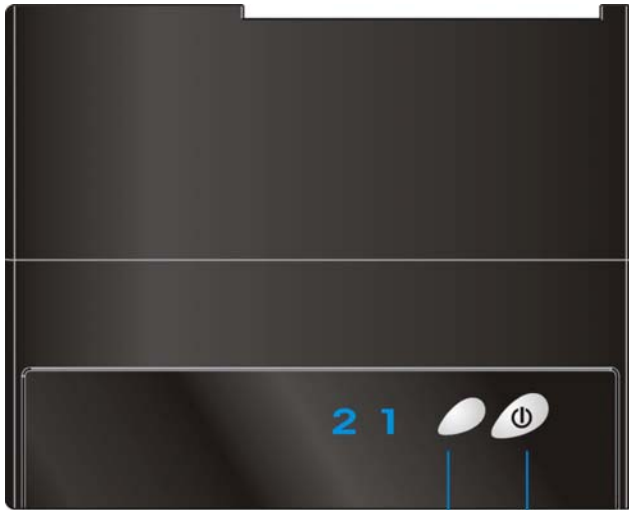

#### ■ Front Panel Buttons and LEDs

##### ❶ Power Button with LED Indicator

Press to turn the transmitter on and off. The indicator in the power button is lit in solid blue when the power is on, and turns red in standby mode.

##### ❷ Source Selection Button

Press to switch between the various inputs of the transmitter. The one of two LED indicators next to this button is lit in solid blue to show current input you switch. Press this button to cycle through connected sources in sequence.

#### **Note:**

Make sure you have connected the ZWD-2422R correctly to your HDTV set with an HDMI cable, and have selected the correct HDMI input on your TV. If you have more than one pair of ZWD-2422, each transmitter and receiver should be at least 6.5 feet away from one another.. If both the transmitter and the receiver exist in the same room, the suggested the distance between the two is 6.5 feet minimum.

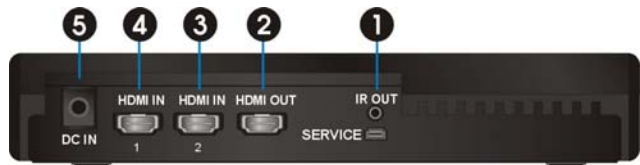

#### ■ Main Unit Back Panel

##### ❶ IR Blaster Extender Jack

Plug the IR Blaster Extender Cable into the IR OUT jack at rear panel of the transmitter. Attach the IR blaster to the device connected to the ZWD-2422T. You can point your AV equipment's existing remote control at the ZWD-2422R receiver (usually close to your TV) to control connected Source device.

##### ❷ HDMI OUT

To use the "loop-through" feature, you can place your 1<sup>st</sup> HDTV set close to the AV equipment, and connect the ZWD-2422T (transmitter) to that HDTV set via HDMI out, and the AV equipment via HDMI in. Then, you can enjoy the same digital content on your 2<sup>nd</sup> HDTV set connected to the ZWD-2422R (receiver), possibly in another room.

##### ❸ ❹ HDMI IN

Connect Transmitter to High-definition audio/video devices that have an HDMI port using a provided HDMI cable.

##### ❺ DC IN

For connecting the ZWD-2422T power adapter.

#### **Note:**

The ZWD-2422T transmitter can be connected two audio/video devices running on HDMI cable, plus looping through the signals to the HDTV set via the HDMI OUT port at the same time. Only one AV source connected to the ZWD-2422T can be selected and displayed on either the HDTV also connected to the ZWD-2422T, or on a 2nd HDTV possibly in a different room, once the transmitter is paired successfully with receiver connected to the 2nd HDTV set.

## B. ZWD-2422R: Full HD Receiver

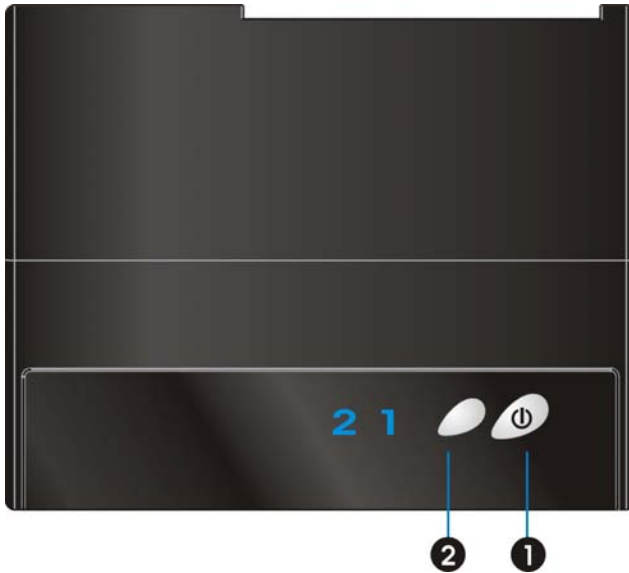

### ■ Front Panel Buttons and LEDs

#### ❶ **Power Button with LED indicator**

Press to turn the receiver on and off. The indicator in the power button lights up in blue when the power is on, and turns red in standby mode.

#### ❷ **Source Selection Button**

Press this button repeatedly until you see the desired video transmitted to your TV set.



### ■ Main Unit Back Panel

#### ❶ **IR Sensor Extender Jack**

Plug the IR Sensor Extender cable into the IR IN jack at the rear panel of the receiver. Generally, sensors with cable are placed near your HDTV set so that you can easily operate and control your AV equipment connected to ZWD-2422T by pointing the remote control to the TV instead of the AV equipment.

#### ❷ **HDMI OUT**

For connecting the HDTV set via an HDMI cable.

#### ❸ **DC IN**

For connecting the ZWD-2422R power adapter.

### C. Remote Controller Unit (RCU) Instruction



Button	Function Description	Operation
POWER	Press to turn the ZWD-2422 Transmitter / Receiver on/off. See the below Note 1 & 2. When both of TX & RX Power LED are red, Please press Power button point at TX and RX separately.	Press it pointing at receiver to enter "Standby" mode and the Loop-through connection is on; Press it pointing at transmitter to enter "Standby" mode and the Loop-through connection is off.
INFO.	Press this button to display related information. Please refer next page for the detail.	Press once to display the current status. Press again to exit OSD.
SOURCE	Press this button to switch audio/video sources connected to the ZWD-2422T.	Press to go to the next input source. Users can see the current setting on the OSD.
CHANNEL	Press this button to change wireless channels manually if the user experiences video noise.	Press once to display the current "Channel" status. Press again within 5 seconds to switch to another channel, and the channel number will be displayed on the OSD.
WIDE	Press this button to enable the "WIDE" mode to boost transmission distance and keep the same video performance; up to 100 feet (1080i content only)	Press to enable and disable WIDE mode. Press again within 5 seconds to enable WIDE mode, and the status will be displayed on OSD.

**Note:**

1. When the system is in active mode, press POWER key on the RCU pointing to transmitter or on the top of transmitter, then both the transmitter and the receiver will enter "Standby mode" (RF disconnected; LED lit in red) and Loop-through display and the 2<sup>nd</sup> display will be off.
2. When the system is in active mode, press POWER key on the RCU pointing to receiver or on the top of receiver, then the transmitter will enter "Listen mode" (RF disconnected; POWER LED lit in purple) and the 2<sup>nd</sup> display (the display attached to the receiver) will be off but Loop-through display (the display attached to the transmitter) will keep on.
3. The "Standby" mode consumes 90% less of the power. User has to press power key on top cover of both transmitter and receiver to resume to "Active mode".

**D. On Screen Display (OSD) vs. RCU Instruction**

**① Press the POWER button**

- (1) Press the power button on the RCU to Transmitter or press the power button on the top of Transmitter to enter "Standby mode" from "active mode".

OSD Displayed:



HDMI1 CH10 WIDE Off 1280x1024  
Standby Mode, Loop-thru Off

- (2) Press the power button on the RCU to Receiver or press the power button on the top of Receiver to enter "Standby mode" from "active mode".

OSD Displayed:



HDMI1 CH10 WIDE Off 1280x1024  
Standby Mode, Loop-thru On

**② Press the INFO button on the RCU, and Signal Quality, Source, Channel, WIDE mode status and resolution will be displayed for user reference.**

OSD Displayed:



HDMI1 CH10 WIDE Off 1280x1024  
Press again to exit the OSD

③ Press the **SOURCE** button on the RCU or on the top of transmitter (or receiver) for audio/video source input selection.

OSD Displayed:

 [HDMI1] CH10 WIDE Off 1280x1024

or

 [HDMI2] CH10 WIDE Off 1280x1024

④ Press the **CHANNEL** button on the RCU to manually switch wireless channels if the user experiences video noise.

Press "Channel" button once for current Channel status displayed on the OSD :

 HDMI1 [CH10] WIDE Off 1280x1024

**Press again to change Channel**

Press the "Channel" button again within 5 seconds to switch Channel manually.

 HDMI1 [CH 8] WIDE Off 1280x1024

**Press again to change Channel**

⑤ Press the **WIDE** button of RCU for longer distance transmission of audio/video contents.

(1) Press once for current WIDE mode status displayed on the OSD (Default is disable):

 HDMI1 CH10 [WIDE Off] 1280x1024

**Press again to switch WIDE mode**

- (2) Press WIDE button again within 5seconds to switch WIDE mode status, OSD Displayed:

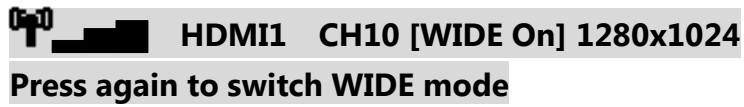

HDMI1 CH10 [WIDE On] 1280x1024  
Press again to switch WIDE mode

**NOTE:** Only the status of the ZWD-2422R (receiver) connected to the HDTV can be displayed on the OSD. The status of the ZWD-2422T (transmitter) HDMI out cannot be displayed.



### 3. Installation

#### Step1: Setup the ZWD-2422T transmitter

Connect Two High-Definition Audio/Video Sources and an HDTV to the ZWD-2422T:

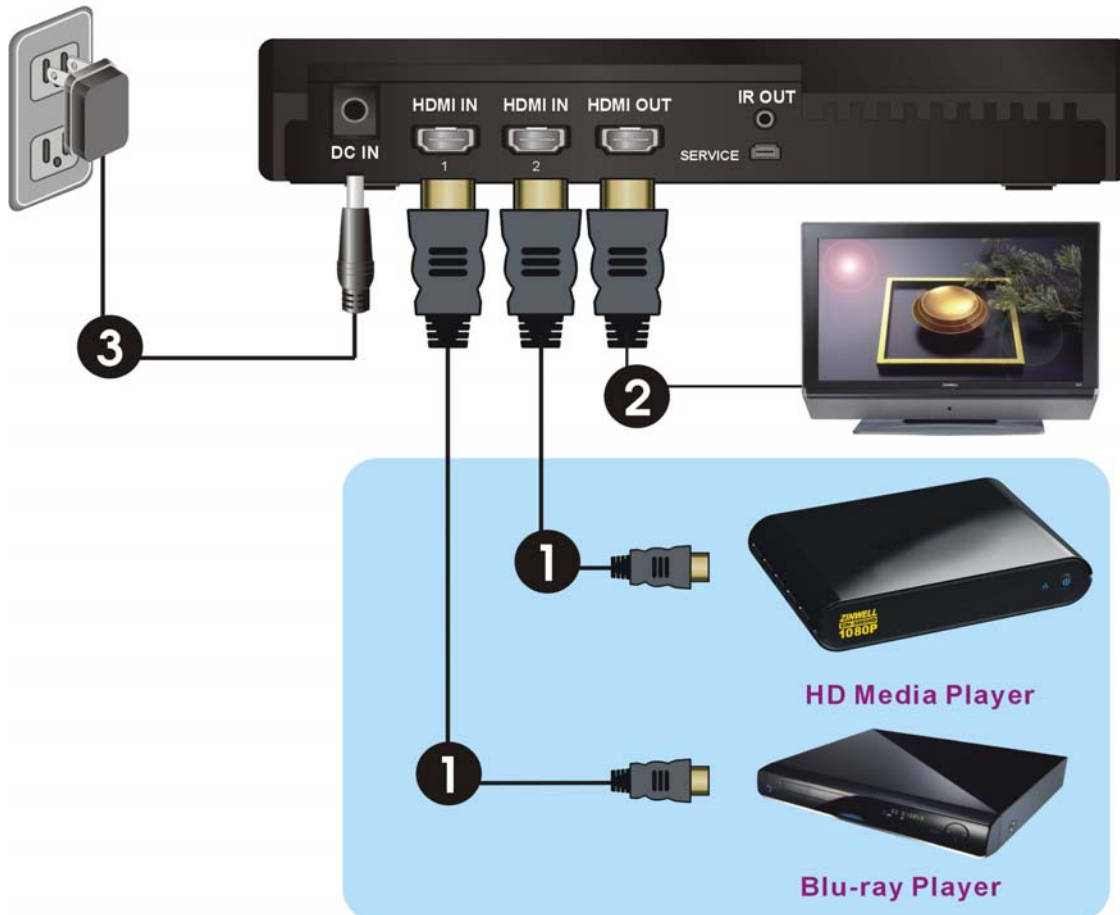

- (1) Connect the ZWD-2422T's (transmitter) "HDMI IN" to the High-Definition AV sources' "HDMI OUT" with an HDMI cable (included). The ZWD-2422T has two HDMI inputs for the latest High-Definition device, like PS3, Blu-ray Player.
- (2) Connect the ZWD-2422T's (transmitter) "HDMI OUT" to the HDTV set's "HDMI IN" port with an HDMI cable for the loop-through output.
- (3) Connect the supplied power adapter to the DC IN jack of the ZWD-2422T and a wall socket. The LED indicator in the POWER button lights up in solid purple when the ZWD-2422T is connected to the power mains.

## Step2: Setup the ZWD-2422R receiver

### HDTV set Connection with ZWD-2422R:



(1) Connect the HDMI cable to the HDMI OUT jack of the ZWD-2422R and to your HDTV set (or an HD projector). Press the **Source / Input** button of your TV's remote to select the appropriate **"HDMI"** video input.

(2) Connect the supplied power adapter to the DC IN jack of the ZWD-2422R and a wall socket. The LED indicator in the POWER button lights up in solid blue when the ZWD-2422R is connected to the power mains.

### Step3: Setup the IR blaster extender cable and IR sensor extender cable

If necessary, connect the Infrared (IR) blaster (or sensor) Extender cable. Users can point hand-held remote control of your High Definition AV equipment at the ZWD-2422R or the HDTV set to operate the source devices, not exceeding the distance of 66 feet at Line-of-sight.

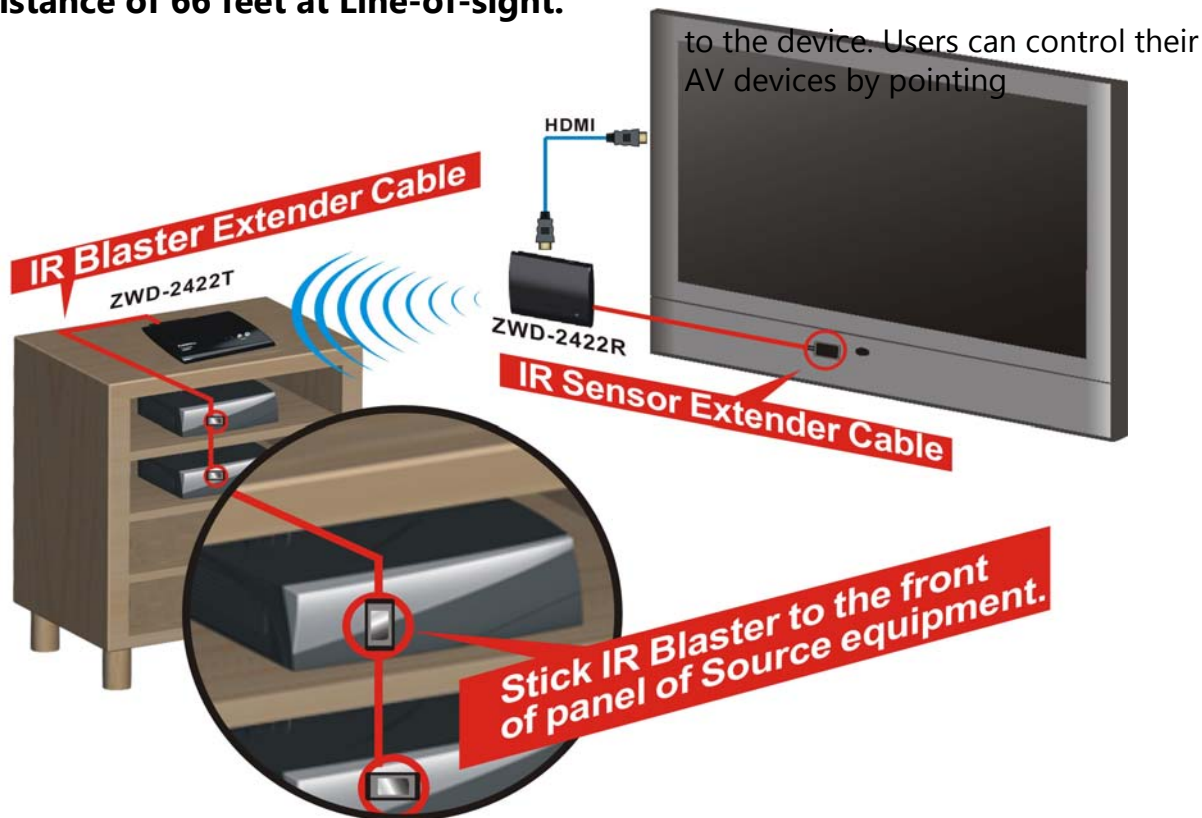

- (1) Plug the IR blaster cable into the IR OUT jack of the ZWD-2422T. Place the IR blaster head near the IR sensor of your High-Definition audio/video devices nearby. The infrared (IR) sensor should be close to the front panel of your High Definition device, usually behind a dark and sometimes reddish plastic window. Please try to manually move the IR blaster in the front of the front panel of your HD device and then press the key of remote control to search a good position of IR response. When the IR blaster cable is connected, it relays infrared command from your remote control

- (2) their remote control to the TV of RX instead of to their AV equipment.
- (2) If the ZWD-2422R will be out of the direct line of sight of your remote controls, plug the IR Sensor Extender cable into the IR IN jack at the rear panel of the ZWD-2422R (receiver) and place the IR sensor on the front of TV for operation.

**Note:**

- (1) The IR sensor supports 36KHz ~ 56KHz (NEC, RC5, RC6) remote's signal protocol. Therefore, it is possible that some devices may not be supported.
- (2) The IR blaster supports 47KHz remote' signal protocol.

#### Step 4: Boot up the ZWD-2422T and ZWD-2422R

- (1) Place the two AAA batteries into the remote control.

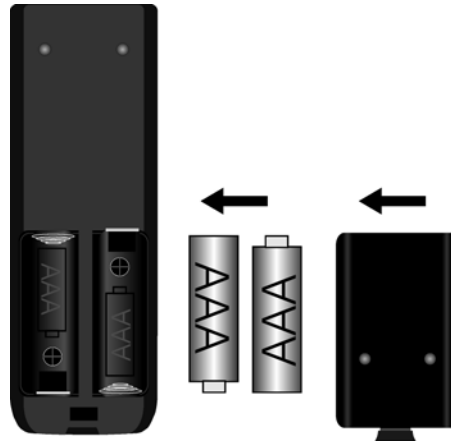

- (2) After the power cord is plugged into the electrical outlet, the ZWD-2422 will be turned on automatically.



- (3) If it is in Standby mode and Loop-thru. display off (Both POWER LED of transmitter and receiver are lit in red), press the POWER button on both transmitter and receiver to turn on the ZWD-2422T and ZWD-2422R. It will take over 1 minute for the system boot up.



- (4) If it is in Standby mode and Loop-thru. display on (Transmitter POWER LED is lit in purple and Receiver POWER LED is lit in red), just press the POWER button of receiver to turn on the ZWD-2422T and ZWD-2422R.  
*Note:* During this period, ZWD-2422T will enter Standby mode and turn off Loop-thru. display when press the POWER button of transmitter or press the POWER key of RCU to transmitter.



- (5) During the warm-up, the POWER LED will blink in blue until the signal link between the ZWD-2422T and the ZWD-2422R is established.



Ensure your TV set or projector is in "HDMI input" mode, and is already powered on.



(6) Press the Source button until you see the video being broadcasted from your device.



(7) If you have electronic devices such as a cordless phone, wireless access point/ router sharing the 5GHz channel frequency, when you use it near the ZWD-2422, you may experience disturbed picture or diminished sound quality. Press the CHANNEL button on the remote control to change the ZWD-2422 to different channels.



**Note:**

A. Changing the ZWD-2422 to a different wireless channel:

	1. Enter the wireless RF channel adjustment mode	2. Changes to the next available RF wireless channel	3. Exit the wireless RF channel adjustment mode
Method	Press the <b>CHANNEL</b> button on the Remote Control Unit (RCU) for current channel status display.	Press the <b>CHANNEL</b> button on the RCU again within 5 seconds to switch channel randomly.	No button is pressed for 5 seconds.
OSD Display Status	<p><b>HDMI1 [CH 8] WIDE Off</b> <b>1280x1024</b> <b>Press again to change Channel</b></p>		Exit.

B. Channel Number Indicating the Wireless Frequency:

<b>WIDE mode Off</b> Frequency [MHz]	US (DFS)		Europe (DFS)		Japan (DFS)	
	Support Region	Channel	Support Region	Channel	Support Region	Channel
5190	V	<b>1</b>	V	<b>1</b>	V	<b>1</b>
5230	V	<b>2</b>	V	<b>2</b>	V	<b>2</b>
5270	V	<b>3</b>	V	<b>3</b>	V	<b>3</b>
5310	V	<b>4</b>	V	<b>4</b>	V	<b>4</b>
5510	V	<b>5</b>	V	<b>5</b>	V	<b>5</b>
5550	V	<b>6</b>	V	<b>6</b>	V	<b>6</b>
5590	X	X	X	X	X	X
5630	X	X	X	X	X	X
5670	V	<b>7</b>	V	<b>7</b>	V	<b>7</b>
5755	V	<b>8</b>	X	X	X	X
5795	V	<b>9</b>	X	X	X	X

<b>WIDE mode ON</b> Frequency [MHz]	US (Non-DFS)		Europe (Non-DFS)		Japan (Non-DFS)	
	Support Region	Channel	Support Region	Channel	Support Region	Channel
5160	X	X	X	X	X	X
5180	V*	<b>1</b>	V	<b>1</b>	V	<b>1</b>
5200	V*	<b>2</b>	V	<b>2</b>	V	<b>2</b>
5220	V*	<b>3</b>	V	<b>3</b>	V	<b>3</b>
5240	V*	<b>4</b>	V	<b>4</b>	V	<b>4</b>
5260~5700	X	X	X	X	X	X
5745	V	<b>5</b>	X	X	X	X
5765	V	<b>6</b>	X	X	X	X
5785	V	<b>7</b>	X	X	X	X
5805	V	<b>8</b>	X	X	X	X
5825	V	<b>9</b>	X	X	X	X

**Note :**

- A. Gray background indicates the DFS region.
- B. \* Means "Limited to indoor use".
- C. Unused Weather Satellite Channels on DFS:
  - i. WIDE mode OFF: Center Frequency 5590MHz, 5630MHz
  - ii. WIDE mode On: Center Frequency 5600MHz, 5620MHz, 5640MHz





- (8) If all the operation is normal, the POWER LED and SOURCE LED will glow in solid blue. Please refer to the next form containing detailed LED description.

**Note:**

- A. Make sure your High-Definition audio/video devices connected to the ZWD-2422T has already been powered on.
- B. Warming-up or source switching time should take approximately 20~30 seconds if the operation is in normal condition.

- (9) TRANSMITTER/RECEIVER Status Indicator on LED and OSD:

LED indicator status light on the front that indicates the following messages:

Power LED	Source LED	Mode	Status Description	OSD Display
Static Purple on TX Static Red on RX	Static Blue on TX Off on RX	Listen	"Loop through" display always on; Wireless transmission off.	 HDMI1 CH10 WIDE off 1280x1024 Standby Mode, Loop-thru On
Static Red	Off	Standby	For the lowest power consumption.	 HDMI1 CH10 WIDE off 1280x1024 Standby Mode, Loop-thru Off
Blinking Blue	Blinking	Initial Boot up or Linking	System boots up Or RF linking. (Note A)	 HDMI1 CH WIDE off Searching available channels....
Static Blue	Blinking 3 times /sec. (Quickly)	Linked	No input detected from selected source. (Note B)	 HDMI1 CH 1 WIDE off No Signal
	Blinking 1 time / sec. (Slowly)		Video frame rate or resolution cannot be recognized. (Note C)	 HDMI1 CH 1 WIDE off Not Supported Format



	Static Blue		Video frame rate or resolution is recognized. Transmission is available with stable RF signal.	
--	-------------	--	--	--

**Note:**

- A. If the RF connection exceeds 80sec without the link established, the link might be lost or the transmitter is most likely out of range. You have to verify the range and adjust or shorten the distance between your HDTV set with the transmitter and the receiver. The maximum video transmission range for 1080p content (WIDE mode off) is up to 66 feet in line of sight (LOS); The maximum video transmission range for 1080i content (WIDE mode on) is up to 100 feet (Line of Sight). < The minimum range is 6.5 feet >
- B. Please make sure the source player have been power on and switched the signal output to HDMI out; also re-plug the HDMI cable to make sure the HDMI connector had settled well.
- C. If there is no video displayed and OSD displayed "Not Supported Format", this is an indication that the video frame rate from the source device is not supported, please refer chapter 5 to switch a supported video timing.

**Step 5: For multi-room audio/video transmission or transmission between different floors, user could press the "WIDE" button on the remote control to enable the Wide mode for longer-range audio/video transmission..**

**Note:**

Only 1080i or below HD video transmission is available when enabling the "Wide" mode (OSD shows: WIDE On). Please shorten the distance and disable the "Wide" mode (OSD shows: WIDE Off) if full HD 1080p 60Hz content transmission is desired.

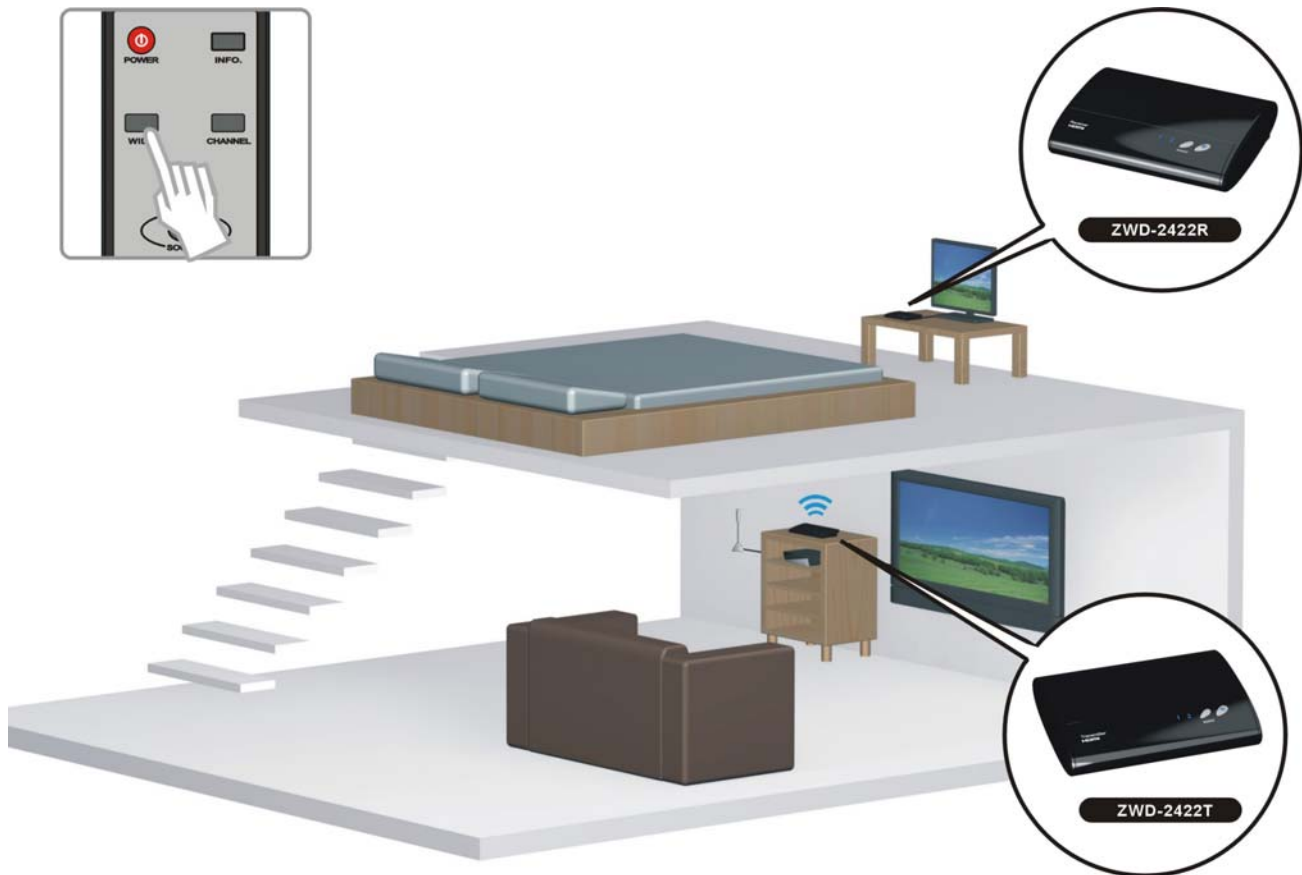

## Step 6: Mounting the ZWD-2422 to the Wall

- (1) Refer the drawing of the bottom page that have relative position of the main holes and attach this paper on wall.

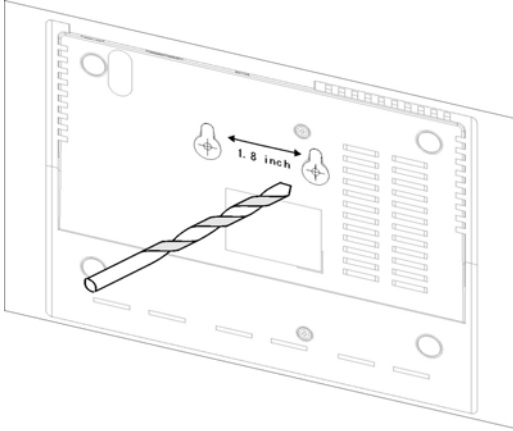

- (5) Place ZWD-2422 main holes over the protruding screws and slide down into position.

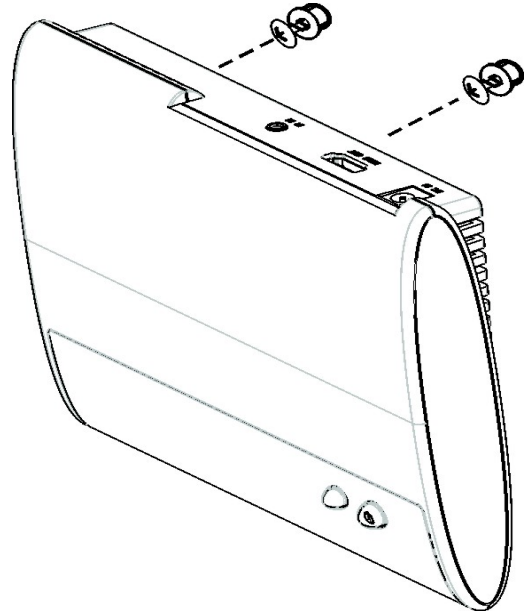

- (2) Drill pilot holes.
- (3) Insert the supplied two Anchors into the wall.

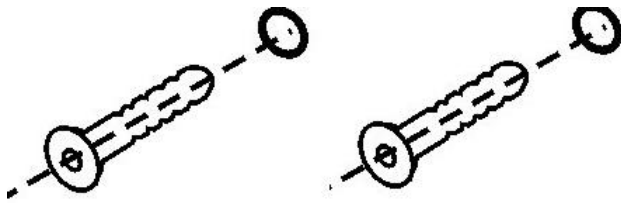

- (4) Insert two screws into the anchors. Leave 1/8" length for mounting the Transmitter or receiver.

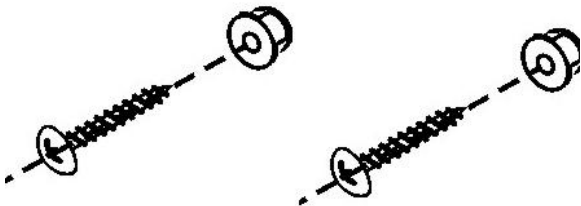

## 4. Troubleshooting

Problem	Solution
<p>The ZWD-2422 front panel power indicator (red LED) doesn't light up.</p>	<ul style="list-style-type: none"> <li>• Check if the power plugs of ZWD-2422T/ZWD-2422R are properly inserted into a functioning power outlet.</li> </ul>
<p>No video is displayed on your TV screen.</p>	<ul style="list-style-type: none"> <li>• <b>The wireless link might require 80 seconds to connect between transmitter and receiver, and show video on the TV screen. Please be patient and wait for a while.</b></li> <li>• Verify that the proper cables have been selected and installed between the ZWD-2422T (transmitter) input and your High-Definition device output.</li> <li>• On your TV side (connected to the ZWD-2422R), select the HDMI as input source.</li> <li>• Verify the POWER LED and SOURCE LED indicator of ZWD-2422.</li> </ul> <p><b>Power LED Flashing in Blue</b>  <b>OSD shows: Searching available channels.....</b>  * Ensure the transmission range between the transmitter and the receiver is not over 66 feet (LOS-line of sight) transmission distance. Move the transmitter closer to the receiver.  * Press <b>CHANNEL</b> on the included remote control to manually change the wireless channel.</p> <p><b>POWER LED in Solid Blue + Slow and Flashing SOURCE LED</b>  <b>OSD shows: No Supported Format</b>  * Ensure your video resolution and frame rate is recognized/ supported and within the transmission range.  *Connect the source device to your TV to check and modify the video format compatibility.</p> <p>*Check if your video resolution with HDMI input from your device is set among 1080p, 1080i, 720p, 576p, or 480p.</p> <p><b>POWER LED in Solid Blue STATUS LED Flash Quickly</b>  <b>OSD shows: No Signal</b>  * Ensure the proper cables are connected between the transmitter and your AV devices.  * Ensure your source devices connected to the ZWD-2422 transmitter are powered on.  * Ensure the proper cables are connected between the receiver and your 2<sup>nd</sup> HDTV near the receiver.</p>
<p>Poor picture quality or intermittent video.</p>	<ul style="list-style-type: none"> <li>• Check if your video resolution with HDMI input from your device is set among 1080p, 1080i, 720p, 576p, or 480p. Please refer to the "Supported Resolution" chapter where the video frame rate from your HD AV device ZWD-2422 can support is</li> </ul>

	<p>defined.</p> <ul style="list-style-type: none"> <li>• Press <b>CHANNEL</b> on ZWD-2422 remote control to manually change the wireless channel.</li> <li>• Ensure the transmission distance is less than 66 feet (LOS).</li> </ul>
No audio.	<ul style="list-style-type: none"> <li>• Check your TV's volume is properly set and not set in "MUTE" mode.</li> <li>• Check if the audio connectors are properly connected.</li> <li>• Ensure the bit rate of audio from the source device can be supported by ZWD-2422. Please refer to the details in Chapter 6 <b>Audio Bit Rate Support</b>.</li> </ul>
No Supported Video /Audio on WIDE mode only.	<ul style="list-style-type: none"> <li>• Check the HDMI output setting of Source device, set up HDMI output format to Auto mode instead of 1080p.</li> <li>• Check Chapter 5 Supported resolution. Some resolution can't be supported on WIDE mode on.</li> </ul>
IR Blaster can't control Source device.	<ul style="list-style-type: none"> <li>• Check where is IR sensor of Source device. Make sure IR Blaster sensor is close and straight to Source device's IR sensor. Please refer Chapter 3, step 3 for reference setup.</li> <li>• Change IR Blaster frequency to meet Source device's requirement. Please continue pressing Source key on the top of Receiver only over 3secs to switch IR Blaster frequency 47K to 58K to 38K recurring. <ul style="list-style-type: none"> <li>- The OSD shows: (Display 5secs)</li> </ul> </li> </ul> <p><b>HDMI1 CH10 WIDE Off 1280x1024</b>  <b>IR Blaster Frequency [47KHz]</b></p> <p>Press Source key on the top of Receiver again to switch IR Blaster frequency.</p>

## 5. Supported Resolution

If the SOURCE LED continues to blink in blue (slower than “no signal” mode); OSD display: “No Supported Format ” and there is no video displayed or the video quality suffers, it indicates that the video frame rate from your A/V source device is not supported. Ensure that the consumer timing of your HD device is compliant with the standard listed below:

Video Format Timings	Resolution	WIDE mode OFF	WIDE mode ON
<b>Primary CEA Video Timing</b>			
640x480p @ 59.94 / 60Hz	480p	YES	YES
720x480p @ 59.94Hz		YES	YES
720x480p @ 60Hz		YES	YES
720x576p @ 50Hz	576p	YES	YES
1280x720p @ 50Hz	720p	YES	YES
1280x720p @ 59.94 / 60Hz		YES	YES
1920x1080i @ 50Hz	1080i	YES	YES
1920x1080i @ 59.94 / 60Hz		YES	YES
1920x1080p @ 50Hz	1080p / 60	YES	n/a
1920x1080p @ 59.94 / 60Hz		YES	n/a
<b>Secondary CEA Video Timing</b>			
1920x1080p @ 23.98 / 24Hz	1080p / 24	YES	YES
1920x1080p @ 25Hz		YES	YES
1920x1080p @ 29.97 / 30Hz		YES	YES
<b>VESA Timing (DVI only)</b>			
640x480 @ 59.94 / 72.809Hz	VGA	YES	YES
800x600 @ 60.317 / 72.188Hz	SVGA	YES	YES
1024x768 @ 60 / 70.069Hz	XGA	YES	YES
1280x768 @ 60 Hz	WXGA	YES	n/a
1280x1024 @ 60 Hz	SXGA	YES	n/a
1600x1200 @ 60Hz	UXGA	YES	n/a

## 6. Audio Bit Rate Support

- Digital Audio from HDMI inputs: Up to 6Mbit/s bit-rate support.
- Support AC3 and DTS.
- 2-channel PCM: 16~24 bits audio sample with 32~96KHz sampling rate as below:

<b>2channel PCM</b>	<b>32KHz</b>	<b>44.1KHz</b>	<b>48KHz</b>	<b>96KHz</b>
16 bits	YES	YES	YES	YES
24 bits	YES	YES	YES	YES

## 7. Product Specification

General Specifications			
Supported Video Resolutions	HDMI Input	1080p, 1080i, 720p, 576p, 480p	
Supported Audio Formats	Digital Audio	Up to 6 Mbps AC3 and DTS	
Transmission Distance	The maximum video transmission range is 20 meters (66 feet) (The minimum range is 2 meters) Line of sight (LOS) scenarios		
System Latency	No latency (<1ms)		
Antenna	High Performance Internal Antennas		
Operating Frequencies	4.9~ 5.9GHz (Include non-DFS and DFS Frequency Bands)		
Power Supply	100~ 240V AC in, 5V 3A DC out Power Adaptor		
Operating Temperature	0~40°C		
Interfaces		ZWD-2422T	ZWD-2422R
A/V Interfaces	HDMI Input	TWO (Type A)	-
	HDMI Output	-One (Loop-through)	One (Type A)
Control Signal Interfaces	IR Sensor	YES	YES
	IR Sensor Extender	-	2.5mm Jack
	IR Blaster Extender	2.5mm Jack	-
Power Interface	Power Input	5V DC Jack	5V DC Jack
Switches	Front Power Switch	YES (One Tack Switch)	YES (One Tack Switch)
	Front Channel Switch	YES (One Tack Switch)	YES (One Tack Switch)
LEDs	Power LED	1 x LED (Three Tone: Blue / Red/purple)	1 x LED (Three Tone: Blue / Red)
	Status LED	2 x Blue LED	2 x Blue LED
	Signal Quality Status	-	OSD Displayed
Dimensions	181(W) x 145(L) x 33(H) mm		181(W) x 145(L) x 33(H) mm



