



# V3R™ USERS MANUAL & INSTALLATION GUIDE

DRAFT



**ELECTRONIC FLEET MANAGEMENT**  
[www.zonarsystems.com](http://www.zonarsystems.com)

## Zonar Systems' V3R™ Hardware Installation Tips For Professional Installers

Zonar Systems' equipment will provide years of reliable service if properly installed and maintained. Zonar equipment is typically installed in heavy vehicle applications and is often subject to extreme temperatures, dust, dirt, vibration, and shock. Proper installation is the critical first step to equipment longevity and optimal performance.

This guide is meant to be a general guideline for the professional installer and technician. While we attempt to point out the most common installation questions and issues; common sense, good housekeeping procedures, attention to detail, safety adherence, and technical competence of the professional installer is critical for a successful installation.

Please refer to your specific vehicle manufacturer guidelines for the installation of electrical components and wiring.

A professional team of Zonar support technicians and engineers are available to answer your installation questions. Contact Zonar at 1-877-843-3847 or by email at [customercare@zonarsystems.com](mailto:customercare@zonarsystems.com).

Thank you,



Andre J Horochiwsky  
Technical Training Manager – Zonar Systems

As Zonar Systems is continuously improving the Product, Zonar may make changes to the Product at any time which may not be reflected in this document.

DRAFT

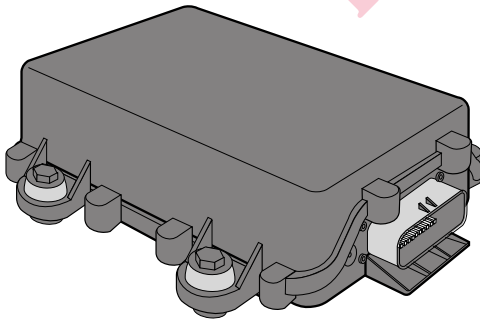

## V3R™

Introduction .....	2
System Overview .....	4
V3R Equipment .....	5
General Guidelines .....	6
V3R Mounting .....	7
V3R Cable Management.....	8
Power Cable Wiring Guidelines.....	9
External GPS Antenna Installation.....	10
System Check.....	11
System Checklist.....	12
System Components and Specifications .....	13
Installation Examples .....	14
System Installation Diagram.....	15
Troubleshooting.....	16-17
Warranty & Notices - FCC Compliance .....	18

© 2013 Zonar Systems • EVIR, ZPass, Ground Traffic Control and V3R are trademarks of Zonar Systems. All Rights Reserved.  
Products and services protected by one or more of the following US patents: 6671646, 6804626, 7117121, 7362229, 7557696, 7564375 and Australian patent: 2002322510

REV: 02/14/13

DRAFT

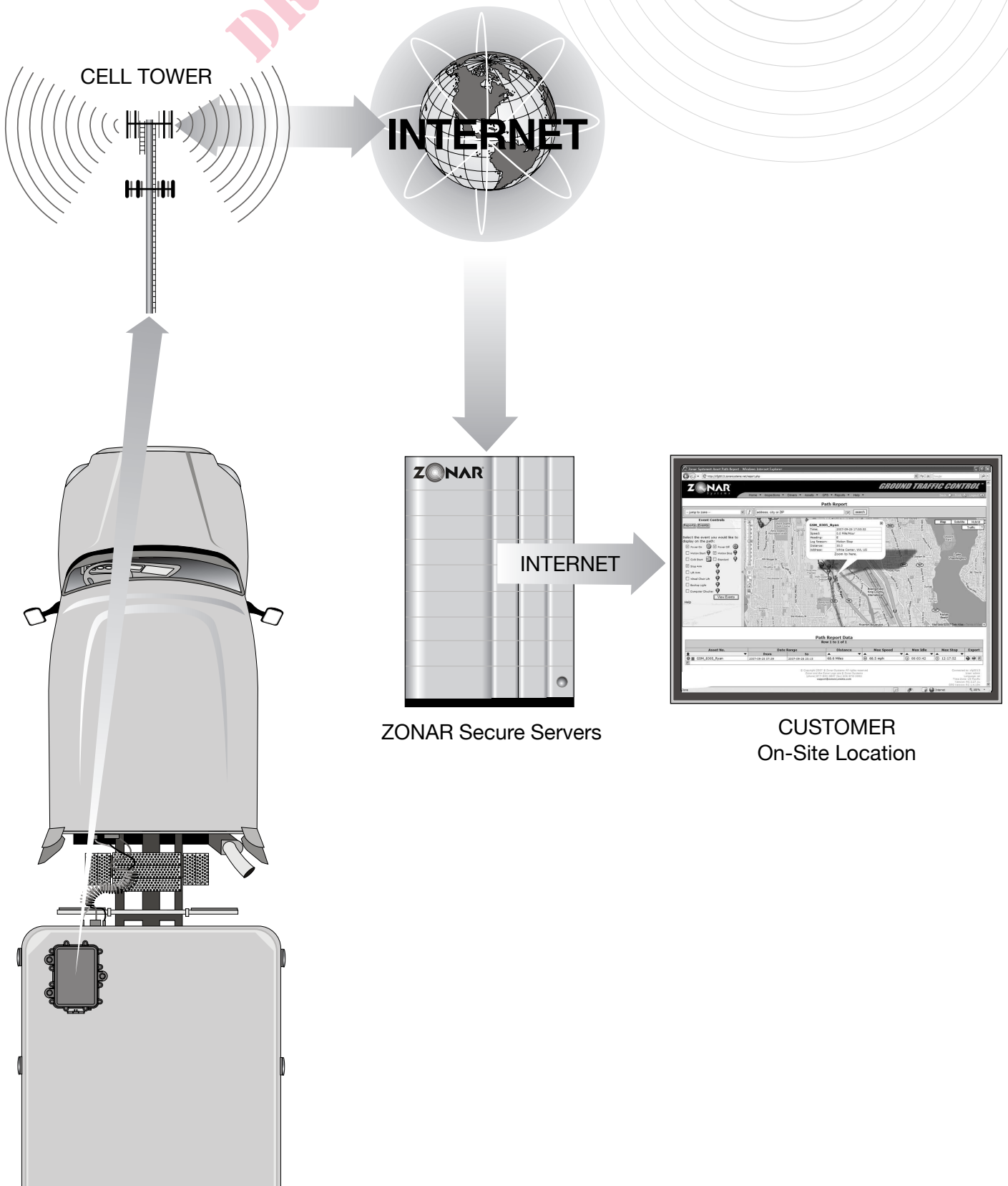

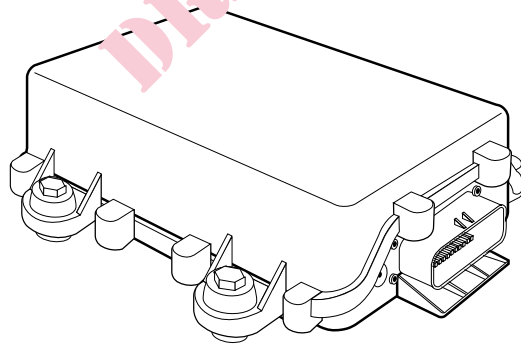

ZONAR V3R™

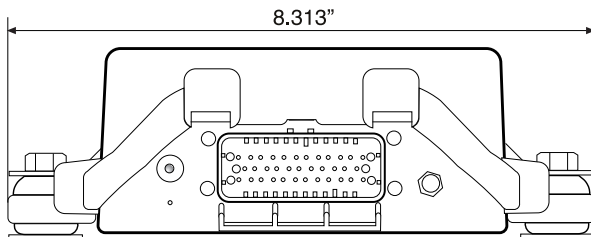
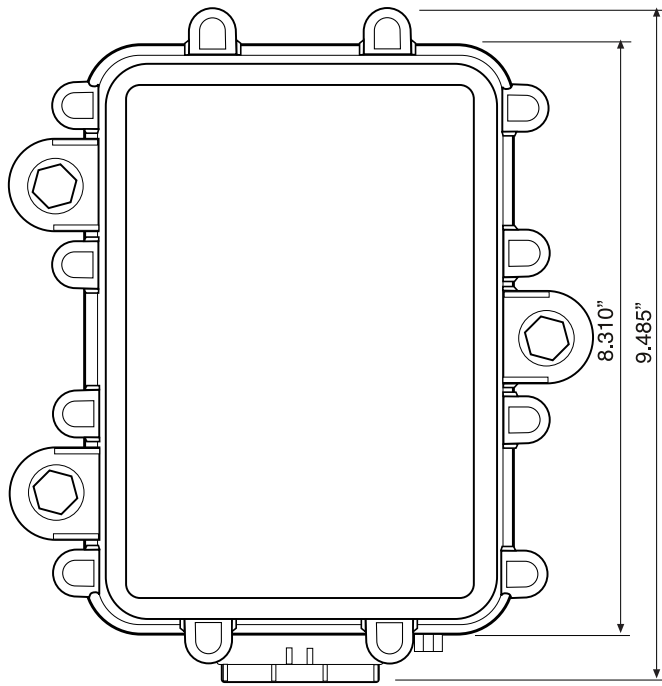
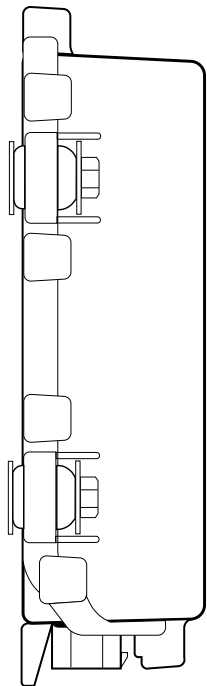
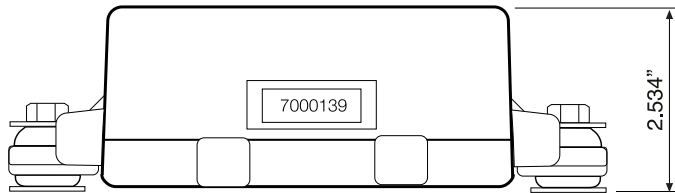

V3R POWER CABLE

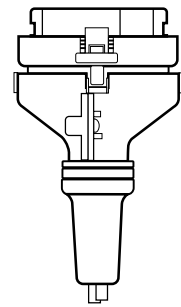

### INSTALLATION HARDWARE

#### Fuse Holders

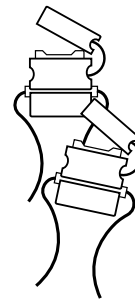

#### Mounting Hardware

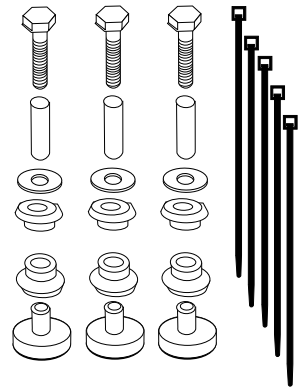

#### ATC Style Fuses

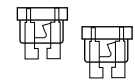

#### Crimpable Butt Splices

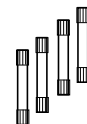

DRAFT

## Layout

- 1) V3R unit must be located a minimum of 8" from any person.
- 2) Do not place Zonar RFID tags, cables, or other equipment in any location or position which may compromise human or equipment safety.
- 3) Verify placement acceptability with State DOT/Law enforcement prior to installation.
- 4) V3R has a temperature range of -40°C (-40°F) to +85°C (+185°F). Do not mount V3 in hot engine compartments or near hot exhaust components.
- 5) Lay all components out prior to installation to check for proper cable length and interference issues.
- 6) Avoid mounting Zonar equipment, antennas and wiring near other radio equipment (e.g., two-way radios), PA equipment and high energy electrical sources (e.g., cables, relays, amplifiers, etc.).



## Electrical

- 1) **Consult the vehicles manufacturer for specific installation guidelines. (HIGHLY RECOMMENDED for Multiplex electrical systems)**
- 2) All power leads (Red and White Power leads) must be connected to the vehicles protected circuitry (e.g. fuse panel, circuit breaker panel, protected circuits). Never electrically connect Zonar equipment to unprotected circuits (e.g. directly to battery).
- 3) It is also required that all power leads (Red and White Power leads) be protected with a 3 to 5 amp fuse and inline fuse holder (included) for optimal system protection.
- 4) Electrical fuses should be installed as close as possible to the source of power.



**Do not open V3R housing. To do so will void the warranty and possibly lead to moisture intrusion.**

## Drill Holes

- 1) Do not drill into the V3R unit. This will void the warranty.
- 2) Capture all drill chips during drilling operations. Do not allow chips to fall onto equipment, furnishings, etc.
- 3) Deburr all drill holes on both sides of drilled surface. Example deburr tool:

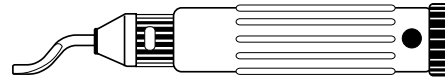

- 4) All drill holes must have a rubber grommet or similar anti-chaffing system installed to protect cable assemblies (e.g. plastic conduit).
- 5) Seal all penetration drill holes which may pass rain water.

## Cable Management

- 1) Strain relieve and support all cable installations.
- 2) Avoid sharp bends and tight radius installations of cables.
- 3) Avoid moving components (e.g. doors, steering shafts, handles, fans, etc.).
- 4) Provide an adequate "Service Loop" i.e. "cable slack" to allow for servicing of equipment.
- 5) Avoid routing cables thru doors, windows, and other pinch points.
- 6) Avoid routing cables in high personnel traffic areas.
- 7) Avoid routing antenna cables near radio and PA equipment.

### CORRECT

- Bend radius adequate
- Hole has grommet

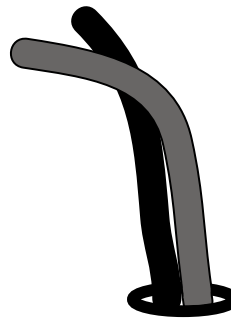

### INCORRECT

- Bend radius too tight
- Hole has sharp edges
- Hole has no grommet

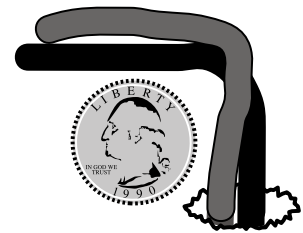

## General Housekeeping

- 1) Capture all drill chips during drilling operations. Do not allow drill chips to fall onto electrical equipment, furnishings, heating ducts, etc. Magnets, sticky tape, vacuums, physical barriers, etc. may all be used to accomplish this task.
- 2) Remove excess sealant. Sealant should be debris/contaminant free (e.g. drill chips), consistent, and uniform in appearance. Clip excess wire tie protrusions.

DRAFT

## V3R Mounting

- 1) Follow all General Guidelines as specified on page 6.
- 2) **Suggested mounting areas:** See page 14.
  - A) **Box type trailers - Left side rooftop (preferred) or front vertical surface (alternate)**
  - B) **Construction equipment - Protected from moving equipment, impact damage and high heat areas**
- 3) Antenna Configurations:
  - A) GPS antenna - V3R utilizes an internal GPS antenna. This antenna works well when the unit has a clear view of the sky (e.g. atop box trailer. If the V3R does not have a clear/unobstructed view of the sky (e.g. engine compartment) an external GPS antenna must be used.
  - B) GSM (cellular antenna) - V3R utilizes an internal GPS antenna. Cellular signals are quite robust and are not easily degraded. As a general rule, if your cellular telephone works in the location you have installed the V3R, this should satisfy the GSM/Cellular requirements of the V3R.

### Magnetic Mount (Provided)

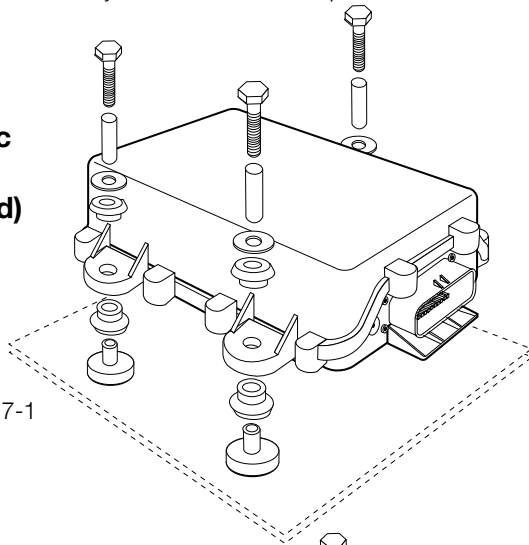

Fig. 7-1

### Bolt Mount (Provided)

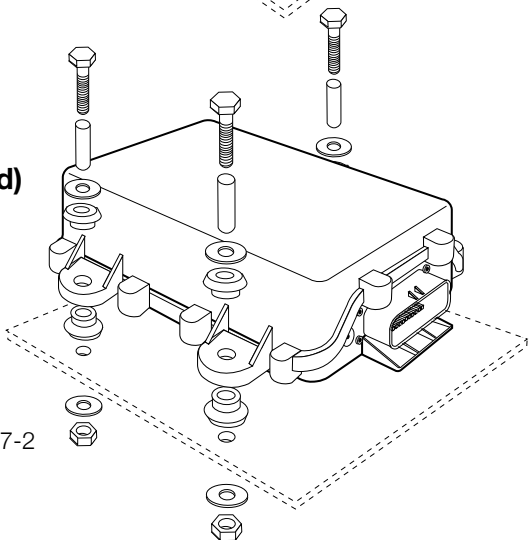
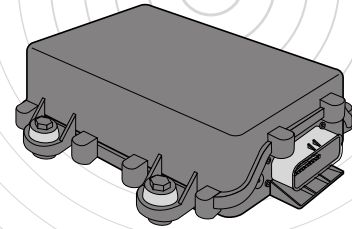

Fig. 7-2

## V3R MOUNTING



- 4) Mount onto interior flat surface large enough to accommodate footprint.
- 5) Avoid mounting equipment in difficult to access areas.
- 6) If enclosing in a radio-shielded area (e.g., metallic enclosure) an external GPS antenna will be necessary for proper operation and performance.
- 7) Avoid mounting Zonar Equipment, antennas and wiring near other radio equipment (e.g., two-way radios), PA equipment and high energy electrical sources (e.g., cables, relays, amplifiers, etc.).
- 8) Avoid mounting equipment in dirty, dusty, or damp areas.
- 9) Please take note of:
  - GPS ID number – Found on white sticker on GPS unit
  - Vehicle or Asset number (e.g. Bulldozer #56)

**Note:** Your Zonar Customer Care Representative or Ground Traffic Control Administrator will need this information.

### Mount V3R Facing Skyward

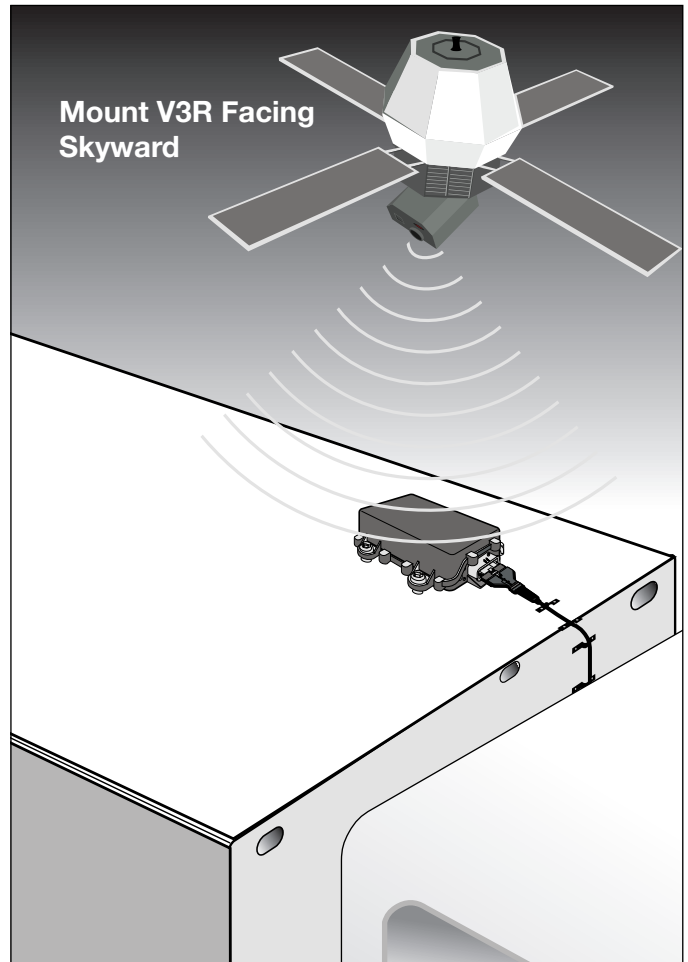

DRAFT

## Electrical Requirements and Cabling Information

- 1) Follow all General Guidelines as specified on page 6.
- 2) It is strongly recommended to keep Zonar electrical connections outside "master kill" circuitry. Failing to do so may lead to inaccurate data (See caution notice this page).
- 3) Connecting V3R to negative/ground side "master kill" circuits (commonly found on construction equipment) may lead to false idle times.
- 4) All power leads must be connected to the vehicle's protected circuitry (e.g. fuse panel, circuit breaker panel, protected circuits). Never electrically connect Zonar equipment to unprotected circuits (e.g. directly to battery).
- 5) It is also required that all power leads (Red and White leads), be protected with a 3 to 5 amp fuse and inline fuse holder (included) for optimal system protection.
- 6) Electrical fuses should be installed as close as possible to the source of power.
- 7) Power Bundle wiring – 4 Pin, 3 wires
  - A. Red – Constant DC (+8 VDC - +30 VDC), dependent on system type
  - B. Black – Ground must be less than 1 ohm (measure from 4 Pin connector to chassis attachment point)
  - C. White - Switched Power
    - The White wire must be connected to a power source that is active only when the engine is running or the system will not track idle time properly*
    - i. Engine running (+8 VDC to +30 VDC)
    - ii. Engine NOT running (0 VDC)
    - iii. Engine NOT running (key position ACC or Accessory) Mode (0 VDC)



**If power cabling is not connected and powered as described in paragraph 7, one or more of the following may occur, contact Zonar for additional info:**

- A. Cold Start flags (an indicator that a unit lost and regained constant power)
- B. Inaccurate idle and stop times
- C. Inaccurate hour meter data
- D. Inaccurate mileage data
- E. Missing path data
- F. Straight line data segments

**Please contact the vehicle manufacturer for any vehicle specific electrical questions.**

## 21' Power Cable

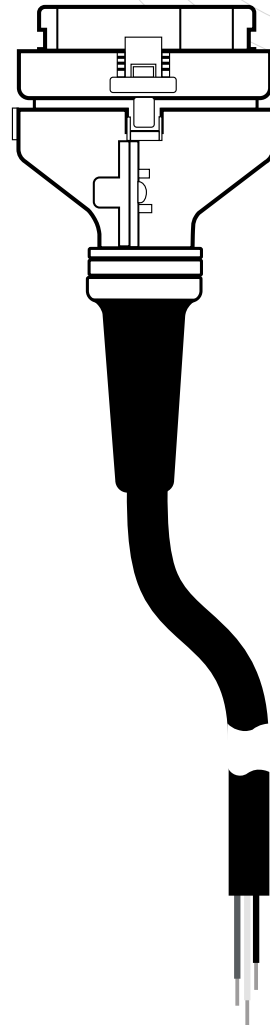



DRAFT

## Wiring Guidelines for Zonar Power Cables

The recommended method for power termination on the Zonar V3R system is the use of Add-a-Circuit fuse taps. Whenever possible, use fuse taps for power termination. If, due to the particular make/model/year of the vehicle being installed, fuse taps cannot be used then the poke and weave method of termination can be utilized. All wiring terminations **MUST** be fused regardless of Add-a-Circuit or poke and weave.

When installing Add-a-Circuit fuse taps, ensure that the fuse tap seats fully in the correct location. If another fuse, a relay, or any other object in the fuse panel prevents the fuse tap from seating fully, relocate the fuse tap. It is not permissible for the fuse tap to rub or make contact with other items in the fuse panel. In addition, you must be able to re-secure the fuse panel cover or door once the fuse tap is installed. Whenever possible, use an empty location in the fuse panel that does not have an existing fuse. If it is not possible to use an empty location, ensure that the existing fuse is placed in the correct location on the fuse tap. See Fig. 9-1

Whenever it is not possible to utilize Add-a-Circuit fuse taps then the poke and weave method should be used.

- 1) First locate the proper wire where the poke and weave method is to be installed. Strip 3/4" to 1" of insulation from the wire in the vehicle to be installed. Spread the wire strands apart as shown. See Fig. 9-2
- 2) Strip 1" to 1 1/2" of insulation from the wire in the fused link to be installed. See Fig. 9-3
- 3) Insert the wire from the fused link into the spread wire in the vehicle. Wrap around the wire several times. See Fig. 9-4
- 4) Cover the exposed wires with several wraps of electrical tape or mastic. Place one wire tie over the electric tape over the exact location where the wires are 'wrapped' together. Place another wire tie 1" to 2" from the first wire tie, to secure the two wires together and as stress relief. See Fig. 9-5

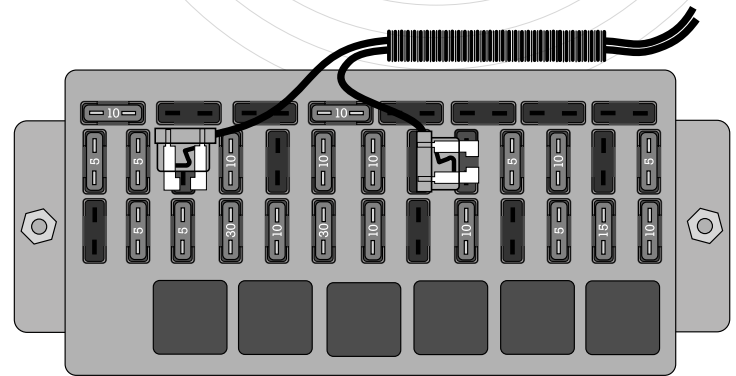

Fig. 9-1

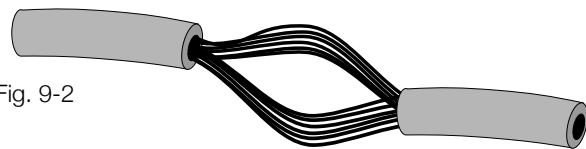

Fig. 9-2

**CAUTION: Only "LittleFuse" (www.littlefuse.com) Add-A-Circuit taps are authorized for use with Zonar Equipment.**

**Full size: (ATO) P/N FHA200  
Mini version: P/N FHM200**



Fig. 9-3

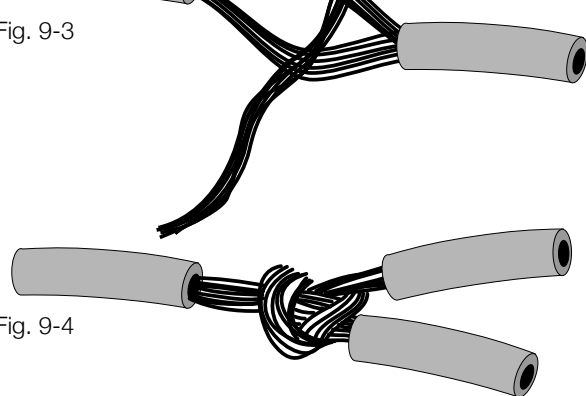

Fig. 9-4

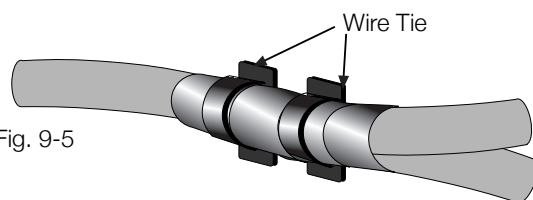
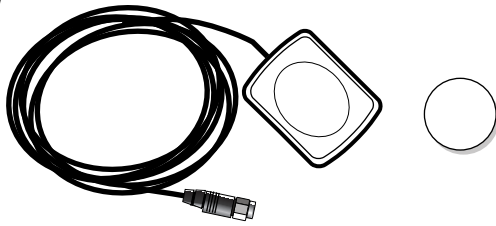

Fig. 9-5

DRAFT

## External GPS Antenna and Double Sided Adhesive (Optional)



- 1) Required when the V3R does not have an upward facing clear view of the open sky.
- 2) Suggested mounting area - as high on the vehicle as possible, facing upward. Protect from moving machinery and falling debris.
- 3) Follow all General Guidelines as specified on page 6.
- 4) May be magnetically mounted or mounted via optional aluminum plate and screw for non-magnetic surfaces, see Fig. 10-1.
- 5) Ensure a clear antenna view of the open sky.
- 6) Maintain a minimum of 6 inches from any rooftop edge or ledge, see Fig. 10-1.
- 7) Drill, deburr, grommet, weather seal, cable thru hole as required. Drill hole size - 1/2" (.500"); grommet size - 3/8" (.375").
- 8) Protect exposed GPS cable with automotive grade impact and cut resistant loom.

**Note:** For optimal system performance Zonar recommends rooftop mounting with a clear view of the sky.

- Drill hole size: 1/2" (.500")
- Grommet size: 3/8" (.375") I.D.
- Drill, Deburr, grommet, weather seal, cable thru hole as required

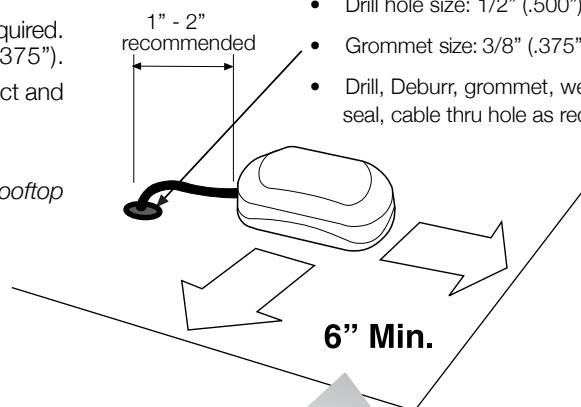

- Allow a minimum of 6 inches from any edge or ledge

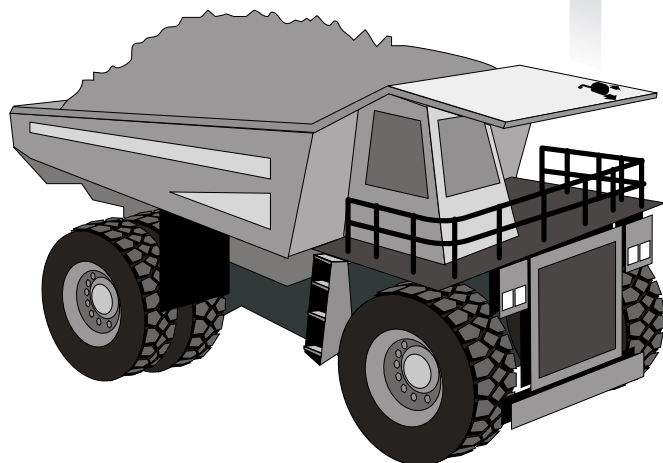
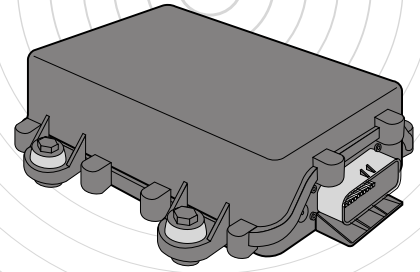

Fig. 10-1

**DRAFT****System Check:**

- 1) Installers are required to perform a full functional check to verify proper installation and operation. A complete functional check includes Ground Traffic Control™ confirmation.
- 2) Constant (RED wire) power check
  - A. Remove inline fuse on constant power (Red wire) and measure voltage at red fuse holder.
- 3) Switched power (White wire) power check
  - A. Power to this lead should only be present when the engine is on and/or GPS tracking is desired. Wiring this to constant power will lead to high and inaccurate idle times.
  - B. Remove inline fuse on switched power (White wire) and measure voltage at fuse holder:  
Engine running = 8 to 30 VDC  
Engine Off = 0 Volts
- 4) Final check
  - A. Turn engine on for 4 minutes or more, then turn off engine.
  - B. In Zonar's Ground Traffic Control™ export path CSV (GPS, path report), ensure exported CSV contains:
    1. Cold Start
    2. Power-On event
    3. Power-Off event
    4. Idle Event (idles must be over 1 minute)

**Note:** A proper and complete functional check requires the engine to be running.

**Contact Zonar at 1-877-843-3847 or by email at [customercare@zonarsystems.com](mailto:customercare@zonarsystems.com) if you encounter any issues or difficulties.**



INSPECT • TRACK • KNOW

DRAFT

Customer:	Yard:	Date:	Asset #:
Installer:	Location:	GPS ID:	
Vehicle Odometer Value:		Vehicle I.D. (e.g., Vin, Plate#, Make, Model, Year)	
Vehicle Hour Meter value (if monitoring engine hours)			

System Check	Value	Notes
<b>General Layout</b>		
General condition - components level, even, straight, etc?		
System layout conforms to your established standard?		
<b>Drilling and Cutting</b>		
All drill holes grommeted (or otherwise protected), deburred, sealed (weather penetrations only)		
All chips captured?		
<b>Cable Management</b>		
All cables properly ran (tight radius, interference, strain relieved, supported, service looped)?		
<b>Electrical</b>		
System hookup complies to your established standard?		
Red lead voltage verified? (8 -30V constant)		
White lead voltage verified? (8 -30V engine on, 0V engine off)		
Black lead continuity verified? (Grounded to vehicle chassis)		
Crimp integrity verified?		
Fuse holder and fuse installation verified?		
<b>Ground Traffic Control™ System checkout</b>		
Cold start present?		
Power-on check		
Power-off check		
Idle time check? (Requires an idle of over 1 minute)		
GPS Position uploaded to GTC website?		
<b>Post Job</b>		
Key accounted for?		
Vehicle secure?		
Lights, electrical off?		
All debris, refuse, chips removed?		

\_\_\_\_\_  
INSTALLER SIGNATURE

\_\_\_\_\_  
Date



INSPECT • TRACK • KNOW

DRAFT

## Important Notice

It is the Owner's sole responsibility to install and use the Zonar products in a manner that will not cause accidents, personal injury or property damage. For the purposes of this notice, "Owner", "you" and "your" means the party (including any person authorized by that party to use and/or install the Product) that has either: (a) purchased the Product; or (b) leased the Product from Zonar Systems, Inc or its related companies. The Owner of this product is solely responsible for observing safe driving practices. The choice, location, and installation of all components of the Product is critical. If installation is not correct, the Product may not perform at its designed potential or specifications. If in doubt, consult your vehicle's manufacturer.

## System Components & Specifications

### COMPONENTS

- V3R™ GPS Unit
- 3 wire power harness magnetic and bolt-thru mounting kits

### Optional Accessories:

- External GPS Antenna

### SPECIFICATIONS

- Operating Temp: -40°C (-40°F) to +85°C (+185F)
- DC Input Range: 8.0Vdc to 30.0Vdc

### GPS Receiver

- Very High Sensitivity Receiver
- Rapid Acquisition of Satellites
- GPS Signal Acquisition, Tracking and Navigation
- Onboard GPS Data Storage

### DIMENSIONS

- Length: 9.485 in.
- Width: 8.313 in.
- Height: 2.534 in.

### COMMUNICATION

#### GSM Cellular Transceiver

- Quad Band 850/1900 900/1800
- GPRS



INSPECT • TRACK • KNOW

DRAFT

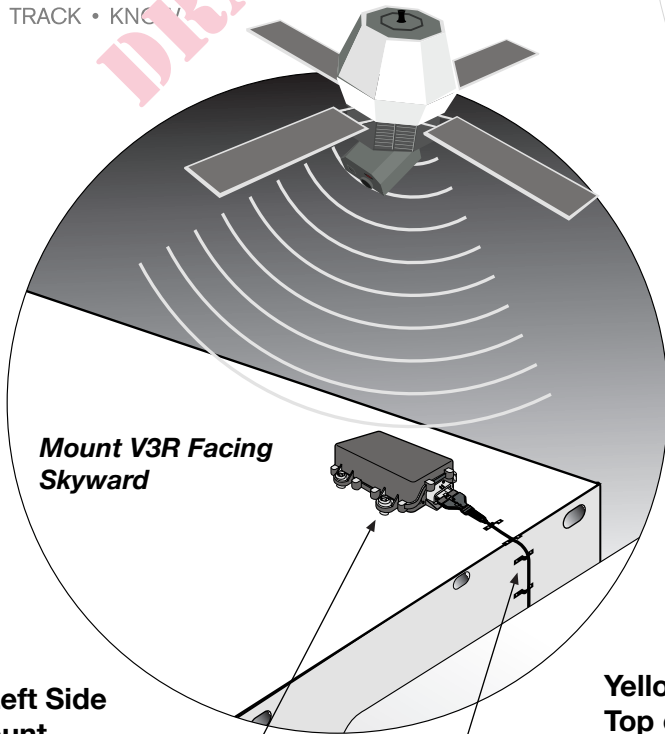

Mount V3R Facing Skyward

Trailer, Left Side Roof Mount - Preferred

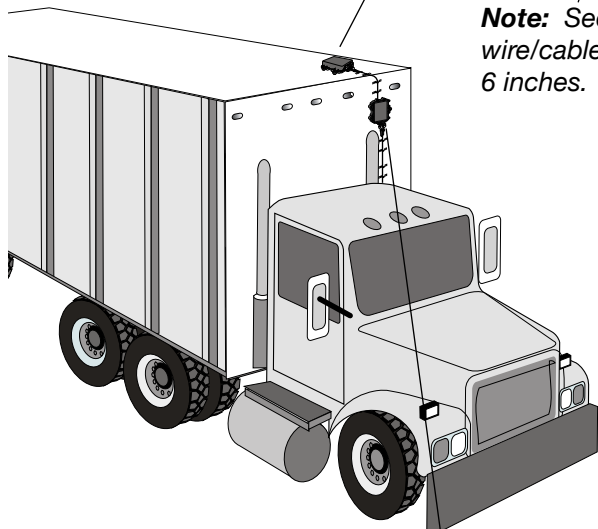

Note: Secure wire/cable every 6 inches.

Trailer Left Side Front High Mount- Alternate

Note: The V3R needs a clear view to the open sky to track GPS satellites. If this is not possible, install optional external GPS antenna.

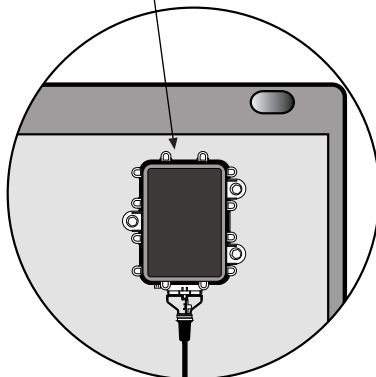

Yellow Iron - Top of Cab Preferred

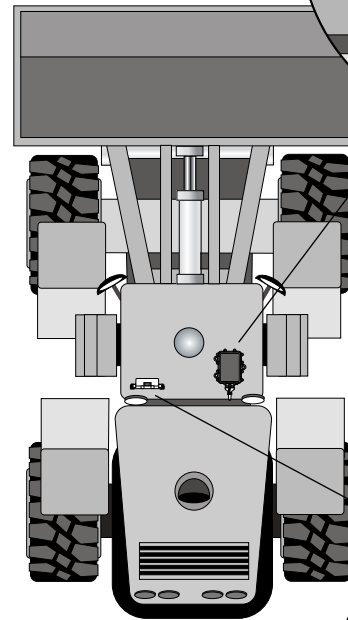

Yellow Iron - Inside Back Cab Alternate

Min. 8" from Operator - External GPS Antenna Required

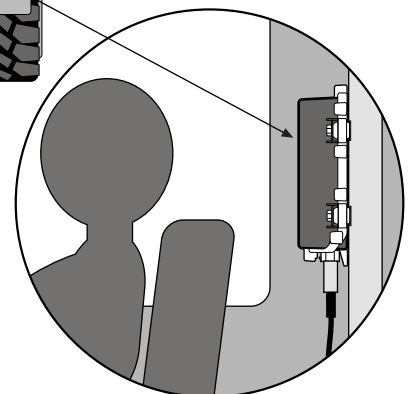

DRAFT

**Zonar V3R™**  
Part#: 10083

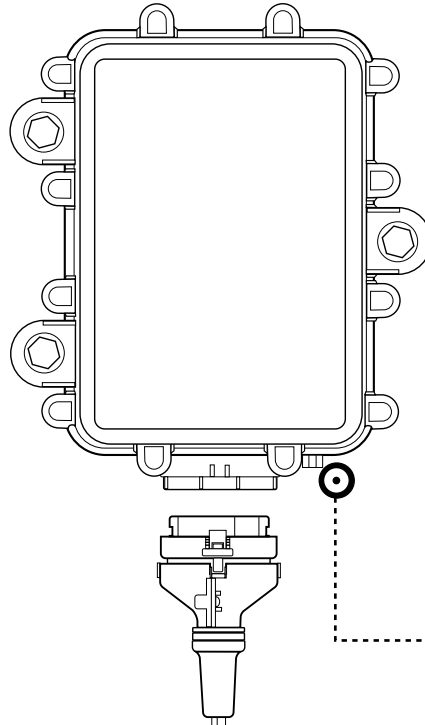

**External GPS Antenna**  
(Optional Accessory)  
Part#: 10006  
Cable Length: 16.5 ft.

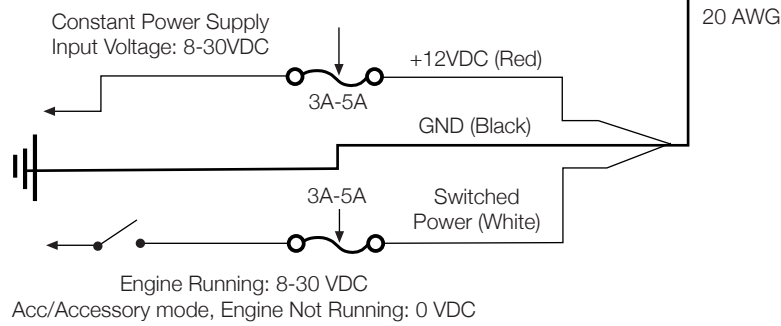
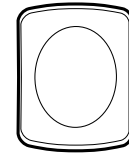

## Common V3R™ issues

The majority of all V3R issues fall into six broad categories:

- **GPS Signal Strength Issues.** The V3R must be given a clear view to the open sky to operate correctly. If this cannot be accomplished an external GPS antenna with a clear view to the sky must be utilized.
- **Cellular Signal Strength Issues.** The V3R cannot transmit in areas that are not covered by cellular towers (typically remote areas). The V3R will store information until cellular reception is restored and then forward all stored data.
- **Cold Starts:** These are the most serious issue because they represent a lack of integrity in the constant power supply to the device. Before any other issue can be resolved, it is important to ensure that the V3R has reliable constant power.
- **Issues with the Engine Run Signal:** These lead to false reporting of engine hours. The problem can be false positive (e.g. V3R records engine hours even if the asset is not running) as well as false negative (e.g. V3R does not record engine hours even though the asset is running)
- **V3R™ Issues:** Inside every V3R is a Zonar V3R™ GPS unit. Therefore, typical V3R issues can arise with any V3R. Since much of the V3R troubleshooting information references LEDs which are hidden inside the waterproof V3R enclosure, in most cases you will need to contact Zonar Customer Support for help.

## White Wire (WW) / Switched Power Electrical Test

1. Engage the equipment master switch.
2. Connect Zonar harness to V3R case
3. Connect the negative meter probe to the Zonar GND wire.
4. Turn engine off.
5. Refer to Figure 1-16 and locate the **WW** pin on the 35-pin connector. Probe this pin with the positive meter probe.
6. To pass the inspection, the meter must show less than 1V.
7. Turn engine on.
8. Probe the WW pin. To pass, the meter should read greater than 5V.

## Inspection Results

If both steps 6 and 8 result in PASS, the V3R passes the electrical inspection. However, if the equipment is acting up only under certain conditions (i.e. hot day, rainy weather) the test should be performed again under those conditions.

If either test results in FAIL, perform the WW continuity tests. Once the wiring has been verified, repeat this test. If the result is FAIL again, swap in a new V3R and repeat.

If the inspection does not pass even after swapping in a new V3R, note the failure condition, and contact Zonar support.

Figure 1-16 V3R Cable Pin Assignments

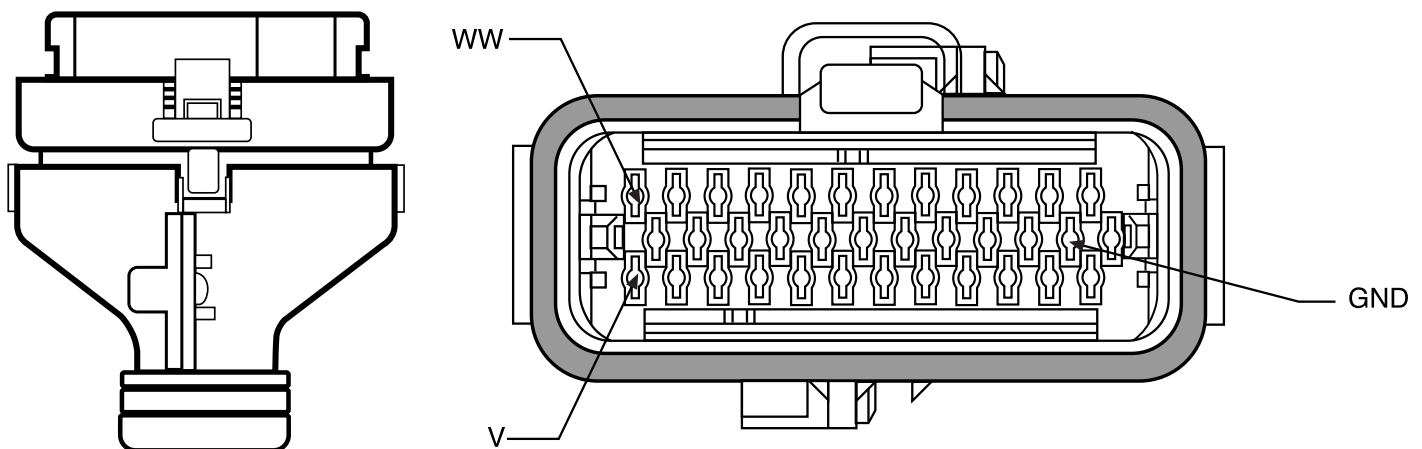





INSPECT • TRACK • KNOW

DRAFT

## Power and Ground Electrical Tests

Unexplained cold starts are the most serious issue because they represent a lack of integrity in the constant power supply to the device. Before any other issue can be resolved, it is important to ensure that the V3R has reliable constant power. Simply following this procedure may not be enough. However, if the equipment is acting up only under certain conditions (i.e. hot day, rainy weather) the test should be performed again (and again?) under these conditions.

1. Engage the equipment master switch
2. Connect Zonar harness to V3R™ case
3. Prepare multi-meter to measure volts.
4. Connect the negative meter probe to Zonar GND wire.
5. Refer to Figure 1-16 and locate the V+ pin on the 35-pin connector. Probe this pin with the positive meter probe.
6. To pass the inspection, the voltage must be at or near battery voltage. If not, perform the **Power and Ground Wiring Inspection**. Then repeat this test.
7. If the test passes, power cycle the V3R, and confirm that a Cold Start event occurred on GTC. Otherwise, note the failure condition, and contact Zonar Support.

### Test Result

If the Electrical test passes, but the V3R continues to show unexplained cold starts, note the conditions under which the cold starts occur. Repeat the **Power and Ground Wiring Inspection** procedure *and* the above procedure under those conditions. If possible, mount the meter in the operator's cab and run the test continuously for several hours.



INSPECT • TRACK • KNOW

**DRAFT**

## Limited Warranty

**LIMITED WARRANTY:** Zonar warrants that the Hardware provided under this agreement is free from all material defects in workmanship under normal use and service. Zonar's warranty period for its Hardware is as follows:

V3 Product Line - 5 Years

EVIRTM - 3 Years

All Other Hardware - 1 Year

The above warranty periods run from the date of shipment. Provided that the Hardware is used and handled as intended, Zonar will replace any failed or functionally impaired Hardware with equivalent Hardware in terms of performance and functionality.

This warranty does not apply to any Hardware that has been misused, altered, willfully abused or that has been damaged due to improper installation by the customer.† Hardware installations must follow Zonar's equipment specific installation guidelines.† If product returned is determined to be damaged due to any of the aforementioned circumstances, the Customer will be charged the price of a refurbished unit plus shipping and handling.

**CUSTOMER'S SOLE AND EXCLUSIVE REMEDY AND ZONAR'S ENTIRE OBLIGATION UNDER THESE LIMITED WARRANTIES** for defective equipment is the repair and replacement of the equipment free of charge by Zonar. Zonar shall not be liable to Customer or any third party for any general, special, punitive, incidental, indirect or consequential damages, or any lost profits or business, arising out of Zonar's Subscription Agreement.



### **Warning: (Part 15.21)**

Changes or modifications not expressly approved by Zonar Systems could void the user's authority to operate the equipment.



### **Caution: RF Exposure (OET Bulletin 65)**

To comply with FCC RF exposure requirements for mobile transmitting devices, the antenna(s) used for this transmitter must be installed to provide a separation distance of at least 20cm (8 Inches) from all persons and must not be co-located or operating in conjunction with any other antenna or transmitter. Users and installers must be provided with antenna installation instructions and transmitter operating conditions for satisfying RF exposure compliance.

Use only supplied and approved antenna's. Use of unauthorized antenna's or modifications could impair signal quality, void your warranty and/or result in violation of FCC regulations.



### **FCC Compliance Statement (Part 15.19) IC Compliance Statement (RSS-210)**

This device complies with Part 15 of the FCC Rules and with RSS-210 of Industry Canada (IC). Operation is subject to the following two conditions:

1. This device may not cause harmful interference, and
2. This device must accept any interference received, including interference that may cause undesired operation.

Cet appareil est conforme aux normes CNR exemptes de licence d'Industrie Canada. Le fonctionnement est soumis aux deux conditions suivantes :

- (1) cet appareil ne doit pas provoquer d'interférences et
- (2) cet appareil doit accepter toute interférence, y compris celles susceptibles de provoquer un fonctionnement non souhaité de l'appareil.



**DRAFT**

