

**Telstra EasyCall® 2**

**Mobile Phone**

# **User Guide**

## **LEGAL INFORMATION**

Copyright © 2011 ZTE CORPORATION.

Version 1.0 March 2011 All rights reserved.

No part of this publication may be excerpted, reproduced, translated or utilized in any form or by any means, electronic or mechanical, including photocopying and microfilm, without the prior written permission of ZTE Corporation.

The manual is published by ZTE Corporation. We reserve the right to make modifications on print errors or update specifications without prior notice.

# Index

<b>1</b>	<b>Introduction .....</b>	<b>5</b>
1.1	General Precautions .....	5
1.2	Precautions While Driving.....	6
1.3	Aircraft Safety.....	6
1.4	Precautions for Medical Devices and Facilities .....	6
1.5	Precautions for Potentially Explosive Atmospheres.....	7
1.6	Battery Safety .....	7
1.7	Limitation of Liability .....	8
1.8	RF Safety (SAR).....	8
<b>2</b>	<b>Getting Started .....</b>	<b>9</b>
2.1	Insert the SIM Card .....	9
2.2	Insert the battery.....	10
2.3	Charging the battery.....	11
2.4	Battery level indicator.....	12
2.5	Switch your phone On .....	12
<b>3</b>	<b>Get to know your phone .....</b>	<b>13</b>
3.1	Your phone .....	13
3.2	Main Display.....	14
3.3	Display Icons .....	14
3.4	Key functions.....	15
3.5	Menu Map.....	17
<b>4</b>	<b>Step by step guide.....</b>	<b>18</b>
4.1	Switch Setting .....	18

4.2	Make and receive a call.....	19
4.3	Add a Contact to your Phone Book.....	19
4.4	Make a call from the Phone Book.....	20
4.5	Messages.....	20
4.6	Text Input methods.....	21
4.7	Phone Book.....	22
4.8	Speed Dial.....	22
4.9	Call History.....	23
4.10	Audio Settings.....	23
4.11	Phone Settings.....	24
4.12	Call Settings.....	25
4.13	Settings > Network Settings.....	25
4.14	Settings > Security Code.....	26
4.15	Organiser > Alarms / Reminders.....	26
4.16	Organiser > Calendar.....	27
4.17	Organiser > Calculator.....	27
4.18	Torch.....	27
4.19	Keylock Switch.....	27
4.20	FM Radio Switch.....	27
4.21	Technical Specifications.....	28
4.22	Service Information.....	29
4.23	Warranty Information.....	29
4.24	Network Locked Device.....	29

# 1 Introduction

This section includes some important information on safety and efficient operation. Please read this section before using the phone.

## 1.1 General Precautions

- The antenna is located in the top portion of the handset, behind the display. When you are using the handset try to avoid shielding the antenna area with your hand. Hold the handset between your thumb and fingers towards the base of the handset. This will leave the antenna area clear to transmit and receive signals. Touching the antenna area affects call quality and may cause the phone to operate at a higher power level than needed.
- Keep the phone out of the reach of small children. The phone may cause injury or be damaged.
- Protect the handset from liquids. Only use a soft dry cloth to clean the handset.
- The handset will be damaged by liquid ingress. The handset contains a liquid detection sticker which changes colour when exposed to liquids. Liquid ingress is not covered by warranty under any circumstances.
- Do not expose the handset to solvents, chemicals or abrasive cleaning products.
- Do not expose the handset or battery to prolonged direct sunlight or temperatures exceeding 50° C. This may damage the battery and high temperatures can shorten the life of electronic devices.
- Please use original accessories only. Damage caused by non-genuine accessories may not be covered by your warranty terms and conditions.
- As your mobile phone can produce electromagnetic field, do not place it near magnetic items such as computer disks or bank cards. Do not expose to metal filings which can stick to the speaker area.
- Using the phone near electrical appliances such as TV, telephone, radio and personal computer may cause interference.

- Do not drop or throw your handset. Rough handling can cause physical damage.
- Do not attempt to disassemble the handset or battery.

## **1.2 Precautions While Driving**

- Obey all safety regulations and do not use your phone while driving.
- Do not place your phone on an airbag or in the airbag deployment area. If a phone is in the airbag deployment area it may be propelled with great force and cause injury to occupants of the vehicle.
- Please turn off your mobile phone at service stations as recommended.

## **1.3 Aircraft Safety**

- Please turn off your mobile phone before boarding as instructed by the airline personnel.
- Disable your alarms to make sure that the phone does not turn on during the flight.

## **1.4 Precautions for Medical Devices and Facilities**

- If you use a pacemaker please keep the phone at least twenty centimetres from the pacemaker when the phone is switched on. Do not carry the phone in your breast pocket. Use the ear opposite the pacemaker to minimize the potential for interference. Switch off the phone immediately if necessary.
- Some phones may interfere with hearing aids. In the event of such interference consult your hearing aid manufacturer to discuss alternatives.
- If you use any other personal medical device, please consult the manufacturer of your device to determine if it is adequately shielded from RF energy.
- Obey the restrictions on the use of mobile phones at prescribed places such as hospitals, airports, service stations, refineries, chemical works etc. Switch off your phone as required.

## **1.5 Precautions for Potentially Explosive Atmospheres**

- Switch off your phone prior to entering any area with potentially explosive atmospheres, such as fuel or chemical transfer or storage facilities.
- Do not remove, install, or charge batteries in such areas. Spark in a potentially explosive atmosphere can cause explosion or fire.
- To avoid possible interference with blasting operations switch off your phone when you are near electrical blasting caps, in a blasting area, or in areas posted “Turn off electronic devices.” Obey all signs and instructions.
- Do not store the phone with flammable or explosive articles.

## **1.6 Battery Safety**

- Do not short-circuit the battery terminals. Do not carry the battery in your pocket in case of accidental short circuits.
- Do not store battery in hot areas or dispose of the battery in a fire.
- Do not disassemble, pierce or modify the battery in any way.
- Please store the battery in a cool dry place if you are not using it.
- The battery is rechargeable but eventually it will wear out. When the operating time (talk time and standby time) is reduced you should replace your battery.
- Please stop using the charger and battery if they are damaged.
- Return the worn-out battery to your service provider or dispose of it in accordance with environmental regulations. Do not dispose of it in household rubbish.

## 1.7 Limitation of Liability

ZTE shall not be liable for any loss of profits or indirect, special, incidental or consequential damages resulting from or arising out of or in connection with using this product, whether or not ZTE had been advised, knew or should have known the possibility of such damages. The user should refer to the enclosed warranty card for full warranty and service information.

## 1.8 RF Safety (SAR)

SAR tests have been completed as per the Radiocommunications Standard 2003 (Human Exposure). The limit defined by this standard is 2.0W/Kg. The highest value SAR recorded for the device is 1.13W/Kg at 850MHz UMTS.

### Notes

The pictures and icons shown in the manual are for reference only. The manufacturer reserves the right to update the product at any time.

Your handset is locked to the Telstra network. If you wish to use your handset with another service provider you need to contact Telstra to obtain the unlocking code. An unlocking fee may apply for this service.



### Warning:

If the battery is damaged do not recharge it. In the unlikely event of battery leakage avoid contact with your skin and wash the affected area thoroughly in water.



## 2 Getting Started

### 2.1 Insert the SIM Card

Remove the battery cover by pressing down on the back cover and sliding the cover down. Insert the SIM card with the metal contacts facing down and the notch on the bottom left corner as shown:

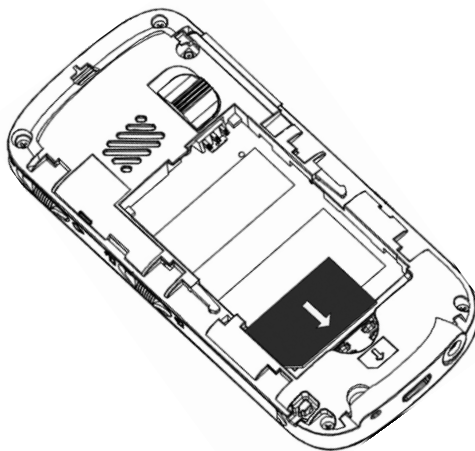

## 2.2 Insert the battery

1. Insert the battery carefully with the contacts located against the gold springs - the battery will only fit one way.
2. Replace the battery cover. Make sure that the cover closes completely.

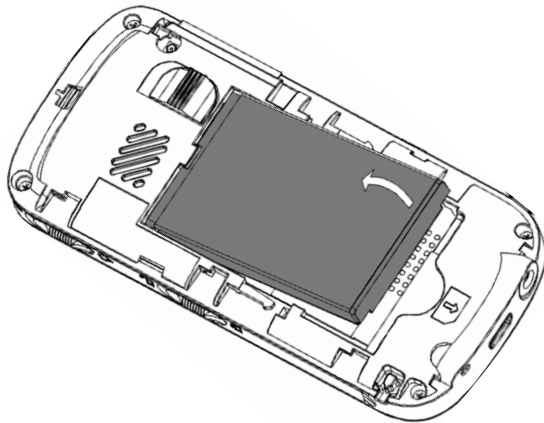



## 2.3 Charging the battery

The phone can be charged in the On or Off state. Make sure that the battery is inserted before charging.

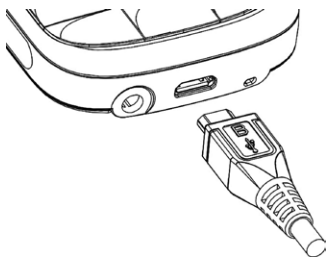
The charger lead is keyed and will only fit one way. Insert the lead carefully observing the correct alignment of the plug and socket.



## 2.4 Battery level indicator

Charging	Charged
	

The phone will give an audible alert when battery is low and display a low battery message on screen. Please recharge the battery promptly to maintain service.

## 2.5 Switch your phone On

Press and hold the **Red key**  for 2 seconds to switch the phone on. Enter the PIN code supplied with your SIM card. Press the green key (OK) to enter.

**Warning:** If you enter the wrong code three times your SIM card will be locked. The phone will request you to enter the PUK code. Contact your service provider to obtain the PUK code if required.

If your handset displays:	
PIN:	Enter the PIN supplied with your SIM card.
Emergency	Invalid SIM. Emergency Calls Only. Device is Network locked to Telstra.
Enter PUK code	Contact your Service Provider.

### 3 Get to know your phone





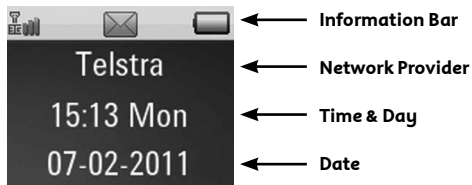

#### 3.1 Your phone









### 3.2 Main Display





### 3.3 Display Icons

	Battery level
	Network signal level
	New SMS message
	SMS memory is full
	Missed call
	Call Forwarding active

	Keypad locked
	Headset inserted
	Alarm enabled
	Silent Mode enabled
	CTM Mode enabled (TTY)
	Roaming

### 3.4 Key functions

Function	Description
<b>Call key</b> <b>(Green Key)</b> 	<ul style="list-style-type: none"><li>• Press to make a call. Press to answer an incoming call.</li><li>• From the idle screen, press to enter the call history list.</li><li>• Press to confirm the function you choose.</li></ul>
<b>End key</b> <b>(Red Key)</b> 	<ul style="list-style-type: none"><li>• Long press to power on or off.</li><li>• Press to go back to previous menu.</li><li>• Clear text and numbers.</li></ul>
<b>Up key</b>	<ul style="list-style-type: none"><li>• From the idle screen, press to enter the Phone Book (Quick Search).</li><li>• Press to move the cursor up.</li></ul>
<b>Down key</b>	<ul style="list-style-type: none"><li>• From the idle screen, press to access the Main Menu.</li><li>• Press to move the cursor down.</li></ul>
<b># key</b>	<ul style="list-style-type: none"><li>• Press to input '#'. Switch text input mode – (Predictive).</li><li>• Hold down to engage / disengage Silent mode.</li></ul>

Function	Description
<b>* key</b>	<ul style="list-style-type: none"> <li>• From the idle screen, press to enter ‘*’, ‘+’, ‘W’, or ‘P’.</li> <li>• Use + for the international dialling prefix.</li> <li>• ‘W’ will wait until the next number is entered into the dialling sequence.</li> <li>• ‘P’ inserts a 3 second pause into the dialling sequence.</li> <li>• In SMS mode, press to access common symbols.</li> </ul>
<b>Numeric keys</b>	<ul style="list-style-type: none"> <li>• Enter numbers 0-9 and characters A-Z.</li> </ul>
<b>Switch</b>	<ul style="list-style-type: none"> <li>• Activate your Switch Call and SMS (see Switch Setting).</li> </ul>
<b>Volume keys</b>	<ul style="list-style-type: none"> <li>• Adjust the volume up and down.</li> </ul>
<b>Torch switch</b>	<ul style="list-style-type: none"> <li>• Turn the torch on or off.</li> </ul>
<b>FM radio key</b>	<ul style="list-style-type: none"> <li>• Turn the FM radio on or off.</li> </ul>
<b>Keylock switch</b>	<ul style="list-style-type: none"> <li>• Lock and unlock keypad.</li> </ul>



## 3.5 Menu Map

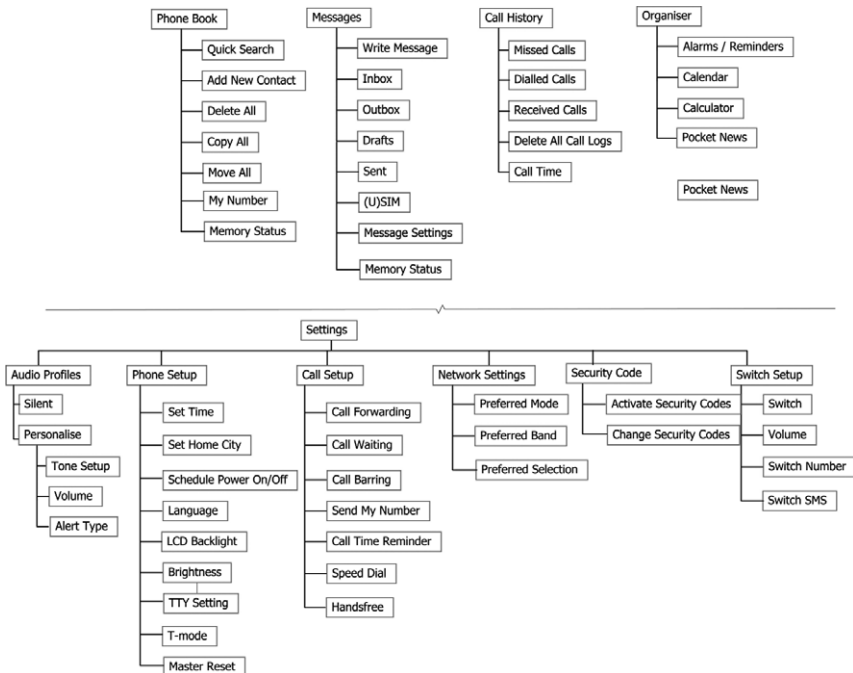

## 4 Step by step guide

### 4.1 Switch Setting

The Switch on the back of the handset can be programmed to make a call and/or send an SMS to friends or relatives simultaneously.

- Press **Down > Down > Down > Down** to get to the **Settings** Menu.
- Go to **Settings > Switch Setup > Switch** to enable this feature. The switch is **Off** by default.
- Go to **Settings > Switch Setup > Switch Number** to program your phone numbers:
  1. The first location will define the voice call number.
  2. Location 2-5 defines the SMS numbers.
- Go to **Settings > Switch Setup > Switch SMS**: To send an automated text message you **must** enter a message in this field.
- When enabled and programmed, pushing the Switch Key will send an SMS message to numbers 2-5 and initiate a call to the first defined number.
- The Alert tone (when enabled) will continue after the call until the Switch Key is pushed back to the down position.
- When the call is connected the handset automatically enables Handsfree (speaker-phone) mode.
- The alert tone volume can be adjusted to Off, Low, Medium or Loud.
- In any state, push the Switch key down to return the phone to standby mode.
- Switch Dialling is still activated when the keypad is locked.

## 4.2 Make and receive a call

- Enter the phone number using the number keys and press the **Green key** to dial. If you enter a wrong digit use the **Red Key** to delete the mistake. Long press the **Red key** to clear all the characters and return to the idle screen.
- Press the **\* key** twice to enter '+' for international dialling.
- Press the **\* key** three times for the Wait symbol 'W' which will hold dialling until the next key is pressed.
- Press the **\* key** four times for the Pause symbol 'P' which adds a 3 second delay into the dialled number.
- Press the **Green key** to answer an incoming call, press **Option > HF on** to enable speaker mode (Handsfree). Press the **Red key** to end or reject the call.
- If you have set speed dial numbers, long press the numeric keys (2, 4 to 9) to dial the corresponding contact.
- Press the **Volume keys** to adjust volume during the call.
- Press and hold the 0 key to select the **In Call** volume level which you can pre-define. Eg. If your normal ear-piece volume is 3, you can set the **In Call** volume setting to 5 which you can use in noisy environments to give a quick volume boost to the earpiece if required. See Audio Settings for more information.
- Press the **Red key** to hang-up (End) the call.

## 4.3 Add a Contact to your Phone Book

**Menu > Phone Book > Add New Contact > To Phone, To SIM > Name > Edit**

Type in the Name, using the keypad letter keys, (eg press the key once for the first letter, twice for the second letter etc.), press OK when finished.

Press the # key to change text input modes (eZiEng, abc, Abc, ABC, 123) if required.

#### **Menu > Phone Book > Add New Contact > To Phone, To SIM > Number > Edit**



Enter the number using the number keys, press OK when finished.

Press **Done** and then **Yes** to Save when prompted.

#### **4.4 Make a call from the Phone Book**

- Press the **Up Arrow Key** to open the **Phone Book Search** view.
- Press the letter keys shown on the keypad to search for the name of your Phone Book contact.  
Eg. Press 5 to search for John. Press 5 twice to search for Karen.
- Use the up and down arrows to scan your Phone Book contacts.
- When you have selected the required contact press **Option > Dial** to make a call to that contact. Select the correct number where multiple numbers are stored.

#### **4.5 Messages**

- The envelope icon  indicates a new message.
- Press the **Green key** to read the message. Press the **Red key** to exit.
- The double envelope icon  indicates the mail box is full. Please delete some SMS messages.
- From the idle screen, press **Down > Down** to access **Messages > Write Message** to start a new message. Press the **Green key** for the option to save or send the SMS.
- Press the **# key** to switch text input methods (eZiEng, abc, Abc, ABC, 123).

- The **Inbox** shows all your received messages. Press **OK** to view the message. Press **Options** to **Reply, Delete, Forward, Delete All, Use Number, Move to (U)SIM, Copy to (U)SIM**.
- The **Outbox** shows messages that failed to send. **Sent** shows sent messages.
- **Drafts** shows all your saved messages which have not been sent.
- Select **Message Settings** for Valid Time, SMS Centre Number, Delivery Report and Cell ID Display options.

## 4.6 Text Input methods

1. When editing text, press the **# key** to change between eZiEng, abc, Abc, ABC, or 123.
2. Input Letters: In **abc** modes, press the letter keys until the correct letter appears.
3. Input Words: In **eZiEng** mode, input each letter with a single key press. The word updates as you enter more letters. Predictive text is based on a built-in dictionary. When you have finished writing the word confirm by pressing the **Green key**. If the word is incorrect, press the **Up/Down key** to view other words in the dictionary or enter using **abc** modes (multi-tap).
4. In **123** mode, press the key to enter a digit. In **eZiEng** mode, hold the key until the number appears.
5. Press the **\* key** to open the symbols list. Press the **Up/Down keys** to select a symbol. In **eZiEng** mode, press the **1 key** for common symbols and use the **Up/Down keys** to highlight the required character.
6. Press the **0 key** to input space (not available in 123 mode).
7. Press the **Red key** to clear a character. Hold the **Red key** to delete all characters.
8. Press the **Up/Down keys** to move the cursor to left or right.

## 4.7 Phone Book

You can save names and numbers to the phone memory and the SIM card.

- Select **Phone Book > Add New Contact** to add a new contact to the SIM or phone.
- Select **Phone Book > Quick Search** to view the phone book. Input the first letters of the name, the phone will list the corresponding records.
- Select **Phone Book > Delete All** to delete all contacts from the phone or SIM. Or select **Option > Delete** in phone book list to delete the contacts one by one.
- Select **Phone Book > Copy All** or **Move All** to copy or move all from SIM to phone or phone to SIM.
- Select **Phone Book > Memory Status** to view SIM card or phone memory status.

## 4.8 Speed Dial

- Once you have saved some Contacts you can assign speed dial keys to your favourite contacts.
- Select **Settings > Call Setup > Speed Dial > Set Number**. Program speed dial keys. Once saved, long press the key to activate **Speed Dial** to the preset number.

### Note:

Speed Dial 1 = Voice Message Bank, Speed Dial 3 = International Message Bank. Speed dial numbers can only be set to numbers already in your **Phone Book**.

- Press and hold the programmed number key to quickly call your assigned Contact.
- Speed Dial is On by default. Go to **Settings > Call Setup > Speed Dial > Status** to enable or disable the feature.

## 4.9 Call History

- From the stand by state, press the **Green key** to check your call history.

## 4.10 Audio Settings

Select **Settings > Audio Profiles > Personalise** to set the following:

### a) Tone Setup

1. Incoming Call	5. Message Tone
2. Alarms / Reminders	6. Keypad Tone
3. Power On	7. Alert Tone
4. Power Off	

- The Power On / Off tones are played when the phone is switched on or off.
- The volume level for the Power On and Off tone is linked to the Ring Tone volume.

### b) Volume

1. Ring Tone	3. Earphone
2. Key Tone	4. In Call Volume *

- \* **Settings > Audio Profile > Personalise > Volume > In Call Volume** sets a preferred second volume setting to quick change the standard earpiece volume. This is activated by long pressing the 0 key during a call.

### c) Alert Type

Ring Only	Vibrate then Ring
Vibrate Only	Light Only
Vibrate and Ring	

## 4.11 Phone Settings

- Select **Settings > Phone Setup > Set Time** to set time (24hrs only) and date. **Network Time** is enabled by default and will automatically update the time from the network. Switch off **Network Time** to set the time and date manually.
- Select **Settings > Phone Setup > Set Home City** if required.
- Select **Settings > Phone Setup > Schedule Power On/Off** to set automatic power on/off time.
- Select **Settings > Phone Setup > Language**. Select from English or Chinese.
- Select **Settings > Phone Setup > LCD Backlight** to set the backlight timeout.
- Select **Settings > Phone Setup > Brightness**.
- Select **Settings > Phone Setup > TTY setting** – Used for teletype equipment.
- Select **Settings > Phone Setup > T-mode** – Enable T-coil support for hearing aids.
- Select **Settings > Phone Setup > Master Reset** – Restore factory settings. The default phone lock code is 0000.



## 4.12 Call Settings

- Select **Settings > Call Setup > Call Forwarding**. Enables your calls to be diverted to another number when your phone is busy, after no reply, or unreachable.
- Select **Settings > Call Setup > Call Waiting**. If you are on a call you will be notified of another incoming call. Press **Options - Swap** to switch between the two calls.
- Select **Settings > Call Setup > Call Barring** to bar your handset from making outgoing calls in various circumstances. This feature requires the Barring password which is available from your service provider.
- Select **Settings > Call Setup > Send My Number**. By default your number is displayed to the other party. You can disable this if preferred.
- Select **Settings > Call Setup > Call Time Reminder > Periodic** (set your required time from 1-3000 seconds). You hear a beep during an active call to remind you of the current call duration.
- Select **Settings > Call Setup > Speed Dial > Set Number**. Program speed dial keys. Once saved, long press the key to activate **Speed Dial** to the preset number. Note: Speed Dial 1 = Voicemail, Speed Dial 3 = International Message Bank. Speed dial numbers can only be set to numbers already in your Contacts.
- Select **Settings > Call Setup > Handsfree**. When switched on, all calls are automatically presented in Handsfree (speaker-phone) mode.

## 4.13 Settings > Network Settings

There is no need to change any of these settings. The handset will automatically choose the best available network.

## 4.14 Settings > Security Code

Select **Settings > Security Code** to Activate or Change PIN codes.

The **Handset Code** is shown on power up and protects the handset from wrong use.

The **PIN** code is stored on the SIM card and protects the SIM (account) from misuse.

## 4.15 Organiser > Alarms / Reminders

Select **Organiser > Alarms/Reminders** (see the table below...).

- Select the required Alarm or Reminder function from the available options.
- Select **Add > Edit** to enter a name (optional).
- Press the down arrow to select the **time field** (hh:mm), press **Change** to enter the alarm time.
- Press the down arrow to select the **date field** (dd.mm – when applicable), press **Change** to enter the required date.
- Press **Done** to save the alarm when finished.
- If the phone is switched off, the alarm function will power on the phone.

Alarm Name	Required Fields	Alarm Type
<b>Birthdays</b>	Set the Name, Time and Date	Annual
<b>Important Dates</b>	Set the Name, Time and Date	Annual
<b>Medication Reminder</b>	Set the Name, Time	Daily
<b>Getting Up</b>	Set the Name, Time	Daily
<b>Entertainment</b>	Set the Name, Time	Daily
<b>Count Down</b>	Set the Name, Countdown time	Once
<b>Others</b>	Set the Name, Time, date, repeat	Set by the user

#### 4.16 Organiser > Calendar

- Go to **Organiser > Calendar** to view the calendar.

#### 4.17 Organiser > Calculator

- Go to **Organiser > Calculator**. Press Up/Down keys to highlight the required functions +, -, \*, /, = and press the **Green key** for **Equals**.
- Press the **Red key** to clear input information and to exit the calculator.

#### 4.18 Torch

Switch the torch on or off using the side switch. The torch works whether the handset is on or off, or in the locked or unlocked state so be careful not to activate the torch while the handset is in your pocket.

#### 4.19 Keylock Switch

Slide the **Keylock switch** down to lock the keypad. If you get an incoming call, you can press the **Green key** to answer or the **Red key** to reject the call. You can also dial emergency numbers when the keypad is locked.

#### 4.20 FM Radio Switch

- Slide the **FM key switch** up to turn the radio on.
- Press the **Up / Down** arrow keys to manually tune to the required frequency.
- Use the side volume keys to adjust the volume.
- Select **Option > Channel List > Option > Edit** to enter a new channel directly. Enter the required frequency, use the # key to enter the decimal point.
- Select **Option > Channel List > Option > Play** to play the selected channel.

- Select **Option > Manual Input** to manually input a channel.
- Select **Option > Preset Auto Search** to preset the playlist with available channels.
- Reception is improved by adding a charger lead or earphone lead.
- When an earphone is inserted you can select Option > Loud Speaker to enable speaker mode.

## Technical Reference

### 4.21 Technical Specifications

Network	UMTS 850 MHz, GSM 900, 1800 MHz
Dimensions L×W×H	Approx 109mm x 50.8mm x 13.5mm
Weight	Approx 86.1g (including standard battery)
Features	UMTS / GSM Handset with SMS, FM Radio, 3.5mm headset jack, LED torch and Programmable Switch Call function.
Battery	1000mA hours, Lithium ion (Li-ion)
Screen	128 x 160 pixels, 1.8" colour LCD
Continuous idle time*	Up to 300 hours (+/- 20%)
Continuous talk time*	Up to 3 hours talk time (+/- 20%)
Charge time	Approximately 3-4 hours
Battery Life	Approximately 400 charge cycles

## 4.22 Service Information

- For Warranty Service directions please see <http://www.zte.com.au>.
- All calls for PIN number enquiries, Network problems, Next G Services, BigPond account information, Web Access, Account and Billing Information, (U)SIM card registration and general enquiries should be directed to Telstra.

## 4.23 Warranty Information

**The warranty does not apply to defects or errors in the product caused by:**

- (a) Reasonable abrasion.
- (b) Misuse including mishandling, physical damage, improper installation, unauthorized disassembly of the product.
- (c) Water, exposure to solvents or any other liquid damage.
- (d) Any unauthorized repair or modification.
- (e) Power surges, lightning damage, fire, flood or other events outside ZTE's reasonable control.
- (f) Use of the product with any unauthorized third party products such as generic chargers.
- (g) Any other cause beyond the range of normal usage for products.

The End User shall have no right to reject, return, or receive a refund for any product from ZTE under the above-mentioned situations. Your statutory rights are not affected.

**Note: Consult the warranty card for full information.**

## 4.24 Network Locked Device

This device is network locked to your service provider. If you wish to use another carrier's SIM card please contact your service provider to obtain the network unlocking code.