

User Manual

Version 1.2



Compact⁴ Star Diagnosis



ads-tec GmbH
Raiffeisenstr.14
D-70771 Leinfelden-Echterdingen
Tel: +49 (0) 711 / 45894-0
Fax: +49 (0) 711 / 45894-990
mailbox@ads-tec.com
www.ads-tec.com

Copyright

© ads-tec GmbH
Raiffeisenstr.14
D-70771 Leinfelden-Echterdingen
Germany

INDEX

ABOUT US	5
1 REMARKS	6
1.1 RELEVANT DATA COMMUNICATION WITH THE DEVICE.....	6
1.2 DESCRIPTION OF THE WARNING SYMBOLS USED IN THIS GUIDE	6
1.3 DATA, IMAGES, AMENDMENTS AND VARIATIONS	6
1.4 TRADEMARKS.....	6
1.5 COPYRIGHT	7
1.6 ENVIRONMENTAL CONDITIONS.....	7
1.7 CERTIFICATIONS / TESTINGS.....	8
1.8 SCOPE OF DELIVERY	8
2 OPERATING INSTRUCTIONS	9
2.1 OPERATING LOCATION	9
2.2 DAMAGES DUE TO IMPROPER USE	9
2.3 WARRANTY / REPAIRS.....	10
2.4 HANDLING AND PROPER DISPOSAL OF LITHIUM BATTERIES	10
2.5 SAFETY INSTRUCTIONS.....	10
3 INSTALLATION	11
3.1 MULTIFUNCTION UNIT	11
3.2 INTERFACES OF THE COMPACT ⁴ MULTIFUNCTION UNIT	13
3.3 FUNCTIONS OF THE MULTIFUNCTION UNIT	16
3.4 EXTERNAL DEVICE DIMENSIONS	17
3.5 EXTERNAL DEVICE DIMENSIONS INCLUDING DOCKING STATION.....	18
4 COMMISSIONING	19
4.1 AVAILABLE INTERFACES	19
4.2 READINESS FOR OPERATION CHECKS	19
5 FRONT PANEL FUNCTIONS	20
5.1 STATUS INDICATORS.....	20
5.2 FRONT CONTROL KEYS.....	21
5.3 TOUCH SCREEN	22
6 INTERFACES	23
6.1 20V DC POWER SUPPLY	23
6.2 14.4V DC ACCUMULATOR OPERATING MODE.....	24
6.3 USB CONNECTIONS	26
6.4 SD CONNECTOR	27

6.5	NETWORK CONNECTION (RJ45)	28
6.6	EXPRESSCARD SLOT	28
6.7	MIC IN	29
6.8	LINE OUT.....	30
6.9	WLAN.....	30
7	HARDWARE-SPECIFIC SOFTWARE.....	31
7.1	SOFT KEYBOARD	37
8	ACCESSORIES.....	39
8.1	DVD DRIVE / EXTERNAL TYPE	39
8.2	SAFETY OF LASER PRODUCTS	40
9	REGULATORY APPROVALS	41
9.1	CERTIFICATIONS / TESTINGS.....	41
9.2	ELECTROMAGNETIC COMPATIBILITY (EMC).....	42
9.3	FCC-APPROVAL.....	43
10	TECHNICAL DETAILS	44
10.1	DISPLAY DATA.....	44
10.2	COMPUTER DATA	44
10.3	GENERAL DATA.....	44
11	SERVICE AND SUPPORT.....	45
11.1	ADS-TEC SUPPORT	45
11.2	COMPANY ADDRESS.....	45

ABOUT US

ads-tec GmbH
Raiffeisenstr. 14

70771 Leinfelden-Echterdingen
Tel: +49 (0) 711 / 45894-0
Fax: +49 (0) 711 / 45894-990
www.ads-tec.com
Germany



ads-tec GmbH provides large enterprises and globally active corporations with cutting edge technology, up-to-date know-how and comprehensive services in the area of automation technology, data processing technology and systems engineering.



ads-tec GmbH implements full automation solutions from planning to commissioning and is specialized in handling and material handling technologies.



The data systems division develops and produces PC based solutions and offers a broad range of industrial PCs, thin clients and embedded systems.



ads-tec is specialized in modifying and optimizing embedded operating systems and develops software tools to complement its hardware platforms.

1 REMARKS

1.1 RELEVANT DATA COMMUNICATION WITH THE DEVICE

The following documents are essential for setting up and operating this device:

USER MANUAL:

Contains information for installation, commissioning and operating the device along with technical data of the device hardware.

1.2 DESCRIPTION OF THE WARNING SYMBOLS USED IN THIS GUIDE



Warning:

The "Warning" symbol precedes warnings on uses or operations that might either lead to personal injury and/or hazards, or to any hardware and software damages.



Note:

This Symbol indicates special notes, terms and/or conditions that strictly need to be observed to ensure optimised and/or zero-defect operations. It also precedes tips and suggestions for efficient unit implementation and software optimisation.

1.3 DATA, IMAGES, AMENDMENTS AND VARIATIONS

The texts, data and images herein are not binding. The right to any subsequent amendment and/or variation due to any technical and engineering progresses in the art whatsoever is hereby reserved.

1.4 TRADEMARKS

It is hereby notified that any software and/or hardware trademarks further to any company brand names as mentioned in this User's Guide are all strictly subject to the various trademark, brand name and patent protection rights.

WINDOWS[®], WINDOWS[®] CE and WINDOWS[®] CE.net[™] are registered trademarks of Microsoft Corp.

Citrix[®] and ICA[®] are registered trademarks of Citrix Systems Inc.

Intel[®] and Pentium[®] are registered trademarks of Intel Corp.

IBM[®], PS/2[®] and VGA[®] are registered trademarks of IBM Corp.

CompactFlash[™] and CF[™] are registered trademarks of SanDisk Corp.

Any further additional trademarks and/or brand names herein, be they domestic or international, are hereby duly acknowledged.

1.5 COPYRIGHT

This User's Guide inclusive of all the images it contains is entirely proprietary and subject to copyright. Any irregular use of this Guide by third parties infringing copyright terms is thus strictly forbidden. Reproduction, translation, as well as electronic and photographic image storage and/or amendment processes, are subject to prior written authorisation directly by M/s. ads-tec GmbH.

Any violation and infringement thereto will be held liable for compensation of all damages.

1.6 ENVIRONMENTAL CONDITIONS

The device may be operated under the following conditions. Failure to observe these specifications will terminate any warranty for this device. Ads-tec cannot be held liable for any damages arising due to improper use and handling.

- Temperature with fan
 - In operation 0 ... 40 C
 - For storage -20 ... 60 C(Because of the integrated maximum temperature memory)

- Humidity
 - In operation 10 ... 85% without any condensate
 - For storage 10 ... 85% without any condensate

- Vibrations
 - In operation MIL-STD-810F acc to method 514.5, figure C1

- Shock resistance
 - In operation 15 G, with a half-wave of 11 ms duration(DIN EN 60068-2-27)

1.7 CERTIFICATIONS / TESTINGS

The Compact 4 system has the following certifications:

CE compatibility (class A)	EN61000-6-2 device complies with standard EN61000-6-4 device complies with standard
UL/cUL201	Application for certification is filed
FCC permission	Application for certification is filed
GOST-R certificate	Application for certification will be filed
MIC certification	Application for certification will be filed
Application for WLAN certificates for 802.11 a/b/g	<u>EU countries</u> 2.400 MHz – 2.483,5 MHz 5.150 MHz – 5.350 MHz 5.470 MHz – 5.725 MHz
	<u>Application for certification in USA / Canada</u> 2.400 MHz - 2483,5 MHz 5.150 MHz - 5.350 MHz 5.725 MHz – 5.875 MHz
	<u>Application for certification in Japan</u> 2.400 MHz – 2.483,5 MHz 5.150 MHz – 5.350 MHz 5.470 MHz – 5.725 MHz
	<u>Application for certification in Australia</u> 2.400 MHz – 2.483,5 MHz 5.150 MHz – 5.350 MHz 5.470 MHz – 5.725 MHz



Note:

A respective conformity declaration for the authority in charge is available on request from the manufacturer.

All connected components, as well as cable connections must also meet these requirements for compliance with the EMC legislation. For this reason, screened bus and LAN cables including screened connectors must be used and installed according to the instructions in this user manual.

1.8 SCOPE OF DELIVERY

The following components are included in the scope of delivery:

- 1 x device
- 1 x transport case
- 1 x 20V DC power supply unit
- 1 x multiplex adapter
- 1 x multifunctional unit
- 1 x DVD drive, external

2 OPERATING INSTRUCTIONS

This device contains electrical voltages and extremely sensitive components. The manufacturer, or a service partner authorised by the manufacturer, should be consulted if you plan to make any modifications. For this type of work, the device must be switched off at the mains and the power lead must be disconnected. Suitable measures for avoiding electrostatic discharge towards parts of the components when touching the equipment must be taken. If the device is opened by an unauthorised person, hazards for the user might arise and any warranty claim will cease.

General instructions:

- All users must read this manual and have access to it at all times.
- Installation, commissioning and operation may only be carried out by trained and qualified staff.
- The security instructions and the manual itself must be observed by all persons who work with this device.
- At the location of use the valid guidelines and regulations for accident prevention must be observed.
- The manual contains the most important instructions on how to use this device in a safe way.
- Appropriate storage, proper transport, installation and commissioning, as well as careful operation are prerequisites for ensuring safe and proper operation of the device.

**Warning:**

Any leads (e.g. power leads, interface cables) may only be connected if the device is switched off in order to avoid damaging the device.

2.1 OPERATING LOCATION

This device is designed for use in industry, in particular in workshops. You have to take care that the environmental conditions indicated in the technical data specification are met. Using the device in non-specified environments, for example, on board ships, or in areas that might contain explosive gases or in extreme heights is prohibited.

**Warning:**

The device may only be switched on after acclimatising to the ambient temperature in order to avoid condensate accumulation. The same applies if the device has previously been exposed to extreme temperature variations.

To avoid overheating: The device must not be exposed to direct radiation by sunlight or any other light or heat source.

2.2 DAMAGES DUE TO IMPROPER USE

Should the service system have evident signs of damages incurred e.g. due to wrong operation or storage conditions or due to improper unit use, the unit must be decommissioned or scrapped. Ensure that it is safe from accidental re-implementation.

2.3 WARRANTY / REPAIRS

During the unit warranty period, any repairs thereto must strictly be conducted solely by the manufacturer or by service personnel that has been duly authorised by the manufacturer.

2.4 HANDLING AND PROPER DISPOSAL OF LITHIUM BATTERIES

**Caution:**

Danger of explosion and the release of toxic substances

Lithium batteries should not be exposed to fire, soldered, recharged, opened, short-circuited, reversed or heated above 100 °C and they should be disposed of properly as well as protected against sunlight, moisture and condensation.

The lithium battery can only be replaced by the same type or a type recommended by the manufacturer.

The used lithium battery should be disposed of in accordance with local legal regulations.

2.5 SAFETY INSTRUCTIONS

**Warning:**

All unit assembly operations must be strictly conducted only under safe, secure and zero-potential conditions.

**Special Note:**

When handling parts and components susceptible to electrical discharge, please accurately observe all the relevant safety provisions.

(DIN EN 61340-5-1 / DIN EN 61340-5-2 refers)



3 INSTALLATION

3.1 MULTIFUNCTION UNIT

The device may be connected to a multifunction unit on the back by using a docking interface.

INSTALLING THE MULTIFUNCTION UNIT

Pay attention when attaching the device on top of the multifunction unit, that the docking plug, and the docking socket located at the Compact4 device, are safely connected with each other. Make sure that the Compact4 device is properly attached to the multifunction unit. (Figure 3)



**Warning:**

If this device is to be used in connection with a multifunction unit, the supplied screws must be used in order to tightly connect the device to it.



The supplied type of screws is 4 x DIN 7984 M5 x 5, black.

3.2 INTERFACES OF THE COMPACT⁴ MULTIFUNCTION UNIT



COM SERIAL INTERFACE (RS 232)

The serial interface is also used for digital and analogue data transmission. The RS 232 interface can be connected by using a commercially available 9-pin SUB-D cable.

PIN NUMBER	SIGNAL NAME
1	DCD
2	RxD
3	TxD
4	DTR
5	GND
6	DSR
7	RTS
8	CTS
9	RI

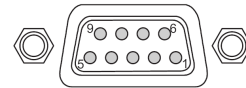

Note:

This interface is not electrically isolated.

CHANGING THE COM ADAPTER

The COM interface is equipped with an attached adapter (gender changer) in order to avoid damage to the COM interface. You can replace this adapter, should it be damaged. Please proceed as follows in order to replace the adapter:

- 1) Open the rubber cover of the Compact⁴ multifunction unit and subsequently loosen both SUB-D bolts by using a suitable screw driver or socket wrench...

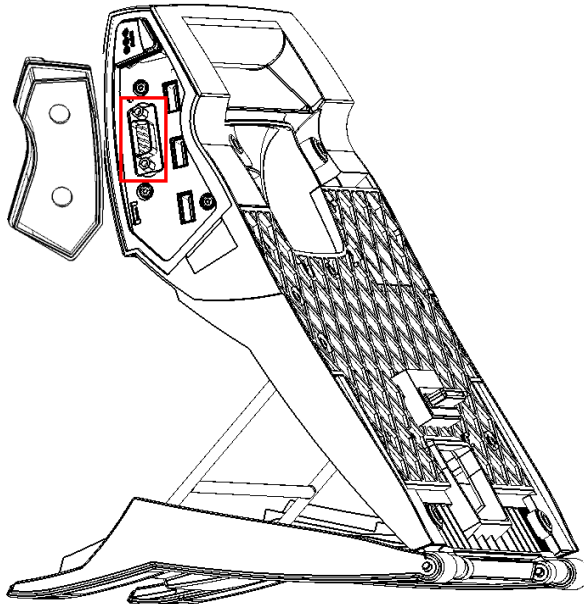

- 2) Once both SUB-D bolts are removed, the adapter (gender changer) can be pulled off.

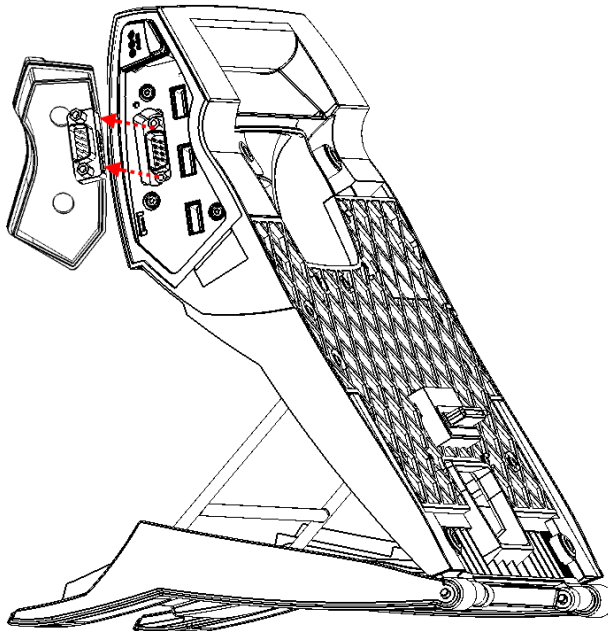

- 3) Attach the new adapter to the COM interface. Tighten both SUB-D bolts with a torque of **NCM TO BE DEFINED** and close the rubber cover.

USB CONNECTIONS

The USB interfaces are used for connecting peripherals with USB connection. The interface complies with the USB 2.0 standard.

PIN NUMBER	SIGNAL NAME
1	VDC
2	D -
3	D+
4	GND

**Note:**

The three available USB interfaces give you the opportunity for a voltage output of 1.5V on one of the USB interfaces at a time. This allows trouble-free operation of external devices, like an external DVD drive. Both remaining ports output a voltage of 0.5V by default in this case.

**Note:**

This interface is not electrically isolated.

MIL CONNECTOR:

The docking station is equipped with a MIL connector. This type of connector is used in automotive industry, specifically in vehicle diagnostics. By using specific software, it allows extracting and analysing data from the vehicle.

**Note:**

If the device is connected to a passenger car via the multifunction unit, the device can be supplied with the required voltage from the vehicle.



3.3 FUNCTIONS OF THE MULTIFUNCTION UNIT

ADJUSTABLE POSITIONING MECHANISM:

The viewing angle of the docking station can be adjusted by using the positioning mechanism.

The positioning mechanism may be fixed in several notch positions at the multifunction unit.



3.4 EXTERNAL DEVICE DIMENSIONS

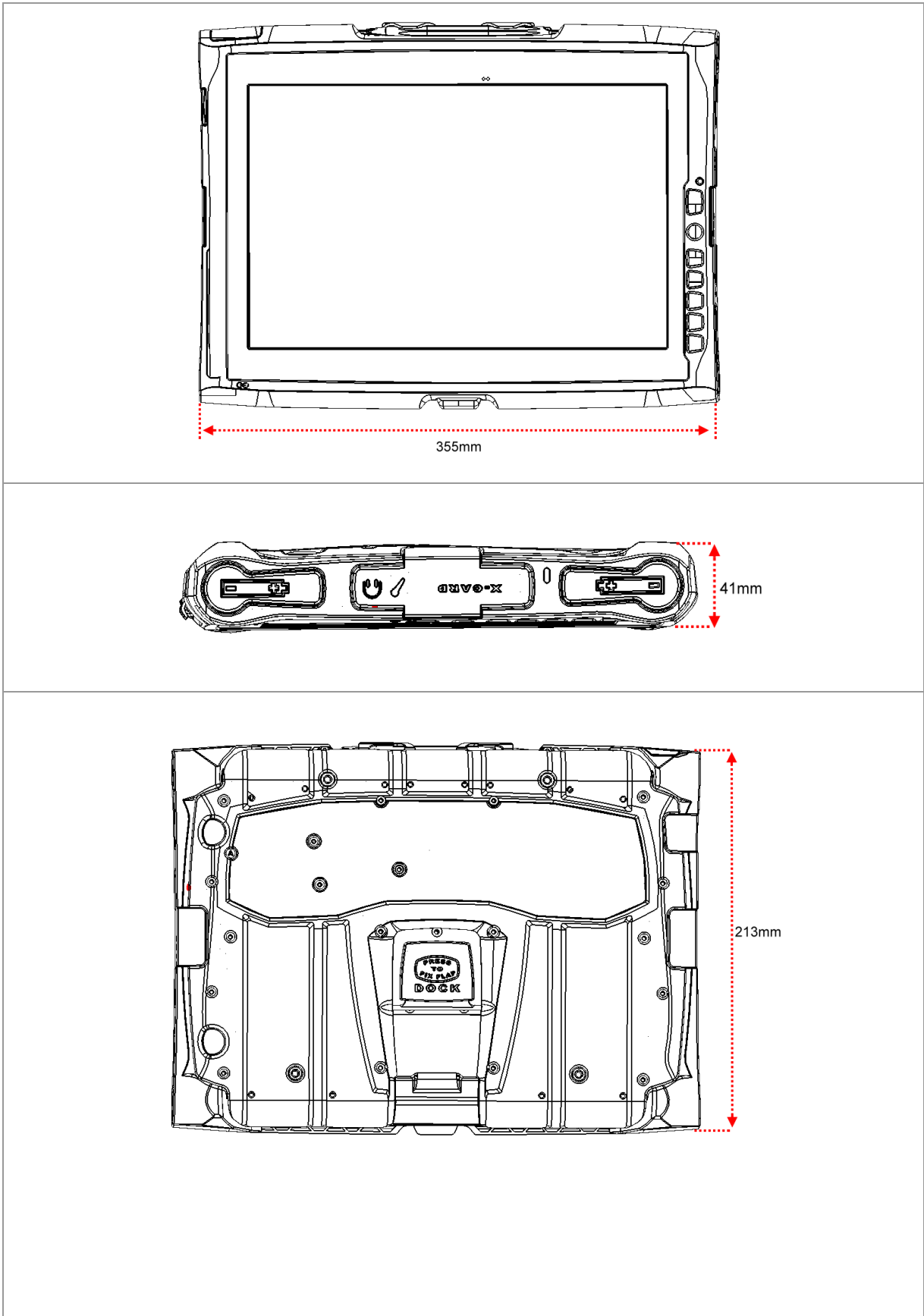

3.5 EXTERNAL DEVICE DIMENSIONS INCLUDING DOCKING STATION

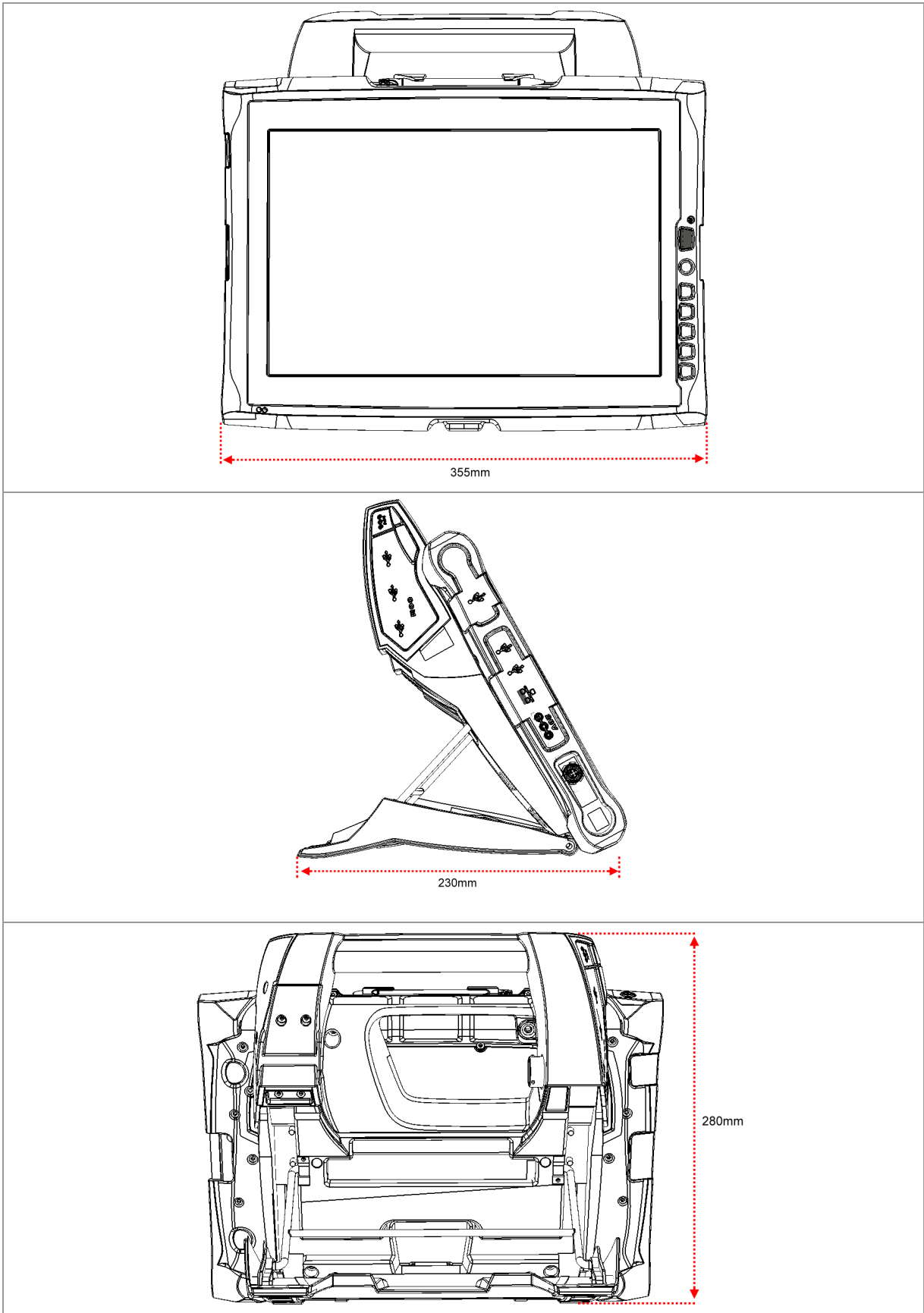

4 COMMISSIONING

The power supply connection and interfaces of this device are installed at the side of case. All supply leads and all required data leads have to be connected before starting commissioning.



Warning:

The device must be switched off before connecting or disconnecting any cables in order to prevent damage to the electronics!

The device may only be switched on after acclimatising to the ambient temperature in order to avoid condensate accumulation. Make sure to meet the permissible voltage requirements for this device.

After switching off and before switching on you must wait for at least 10 seconds.



Note:

The screen of a data cable must always be connected with the connector housing (EMC).

Under the embedded operating system, interfaces must explicitly be enabled and required drivers must be installed in order to be able to use them.

4.1 AVAILABLE INTERFACES

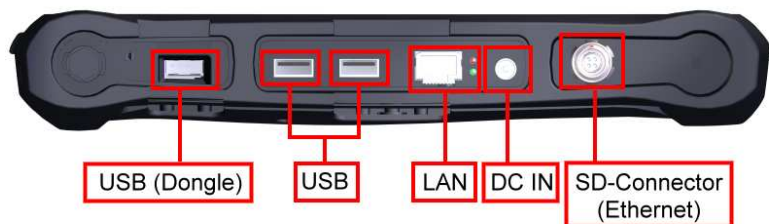

4.2 READINESS FOR OPERATION CHECKS

Accurately check the unit for any hidden damages possibly incurred during improper transport and/or handling or wrong operation site and/or storage conditions (e.g. smoke emissions or formation by the unit, etc.). If any damages are found, the unit must be decommissioned or scrapped. Ensure that it is safe from accidental re-implementation.

5 FRONT PANEL FUNCTIONS

5.1 STATUS INDICATORS



This device is equipped with different status LEDs in the front. These LEDs indicate current events, like the system activity state, the current accumulator charge status and WLAN activities.







SYSTEM LED INDICATORS	DISPLAY BEHAVIOUR	DESCRIPTION
	-	The device is not connected to any power supply (power adapter / accumulator)
	Static	The device is connected to a power supply (power adapter/accumulator) and switched on
	Flashes	The device is in suspend mode (this mode can be set up using the operating system, re-activation via power button)
	Static	Device is accessing the HDD
POWER LED INDICATORS		
	-	Device is not connected to any power supply
	Static	Device is supplied by the charged accumulator
	Static	Device is supplied from an external power supply
	Flashes	Internal accumulators of the device are charged (device must be connected to a power supply (power adapter))
	Static	Device works with the accumulators' residual capacity
WLAN LED INDICATORS		
	Static	Device is not connected with a WLAN network
	Static	Device is connected with a WLAN network

		Flashes	Device is connected with a WLAN network and has data traffic
---	---	---------	--

5.2 FRONT CONTROL KEYS



The keys on the front panel are occupied with the following functions by a specific driver in the soft keyboard:

<u>SYMBOL:</u>	<u>FUNCTION:</u>
	ON / OFF pushbutton for the device (approx. 1 second delayed)
	<u>Level 1:</u> Activate and deactivate the soft keyboard for letter/character input using the touch screen <u>Level 2:</u> Increase the system volume.
	<u>Level 1:</u> Change task (Alt+ESC) in Windows. <u>Level 2:</u> Decrease the system volume.
	<u>Level 1:</u> Freely allocateable, special function <u>Level 2:</u> Increase display brightness
	<u>Level 1:</u> Right mouse-key function <u>Level 2:</u> Decrease display brightness
	Shift key (SHIFT) for activating the second keyboard level. This key must be pressed simultaneously with the desired function key.

**Warning:**

The front control keys should not be operated with a touch stylus but with the fingers, only.

**Note:**

All function keys in the front panel, except for the ON / OFF pushbutton, have 2 function levels. The primary function is activated by simply pushing the respective key. The second function level (small symbol to the top right) can be activated each time by pushing the Fn key first, and then additionally the desired function key. It is important to keep the Fn key always pushed in order to activate the second function level.

**Note:**

If the software keyboard is not installed, only the functions for display settings and volume control are active. The controller display will not be output on the display, in this case. Above described functions are pre-set ex works.

5.3 TOUCH SCREEN

The control system is equipped with an analogue, resistive touch screen. The driver software required for its use is already integrated in the respective operating system.

TOUCH STYLUS

**Note:**

This device is equipped with a supplied touch stylus for comfortably operating the touch screen. This stylus should be used for all works on the device in order to avoid damage to the display.

**Warning:**

The protective film on top of the touch screen must not be removed!

6 INTERFACES

6.1 20V DC POWER SUPPLY



TECHNICAL DATA OF THE POWER ADAPTER

- Power consumption: Max. 70 Watts
- Input voltage: 100...240V AC
- Mains frequency: 50...60Hz

- Current consumption: 3.5A (230V AC)
- Max. switch-on current: < 60A (230V AC)

**Note:**

The typical power consumption of this device is indicated in the "Technical details" chapter.

**Warning:**

This power adapter must never be connected with a Compact³ device. Likewise, the Compact⁴ device must never be operated with a Compact³ power supply unit.

**Note:**

Only approved power cables (e.g. H05VV-F, at least 3 x 1.00mm²) may be used.

6.2 14.4V DC ACCUMULATOR OPERATING MODE

The device is equipped with two accumulator slots, by means of which the device can be supplied with power, alternatively. It is provided with a hot swap function which allows you to replace the accumulator without rebooting.



The accumulators are automatically charged in mains operation (20V).



Note:

If both accumulators are to be replaced while operating the unit, power supply must be ensured by attaching the supplied power adapter. If you want to replace just one accumulator, you can do this without attaching an external power supply.

ACCUMULATOR STATUS RETRIEVAL / REPLACEMENT

The Compact⁴ accumulators can be removed by using a mechanical ejector on the back of the device.



The accumulator status can be retrieved by pushing a button on the accumulator. The accumulator display will light up for a few seconds and show the current accumulator charge status on a scale from 0 to 100. If the display lights red, this represents a weak accumulator. If the display is green, it shows that the accumulator is fully charged. If the device is in operating mode, the accumulator status can be retrieved by using the supplied Battery Information & Diagnostics Tool.



Note:

The "**Hardware specific software**" chapter describes the Battery Information & Diagnosis Tool, which can be used for retrieving the accumulator status while operating the unit.

6.3 USB CONNECTIONS

The USB interfaces are used for connecting peripherals with USB connection. The interfaces comply with the USB 2.0 standard.



PIN NUMBER	SIGNAL NAME
1	VDC
2	D -
3	D+
4	GND



Note:

Two of the available USB connections (see red highlighting) offer the opportunity of outputting a current of 1.5A on one of them at a time. This allows trouble-free operation of external devices, like an external DVD drive. Both remaining ports output a current of 0.5A by default in this case.

6.4 SD CONNECTOR

By using the SD Connector, the device can be connected to an Ethernet network (10/100 MBit). Data throughputs of 10MB can be achieved with a maximum cable length of 5m.



Note:
This interface does not allow booting via the network. If you want to boot the device via the network connection, we recommend using the LAN interface.

PIN NUMBER	SIGNAL NAME
1	RxD+
2	RxD-
3	TxD+
4	TxD-

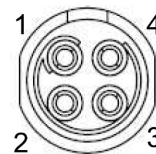

The SD Connect cable must be connected so that the red markers match.

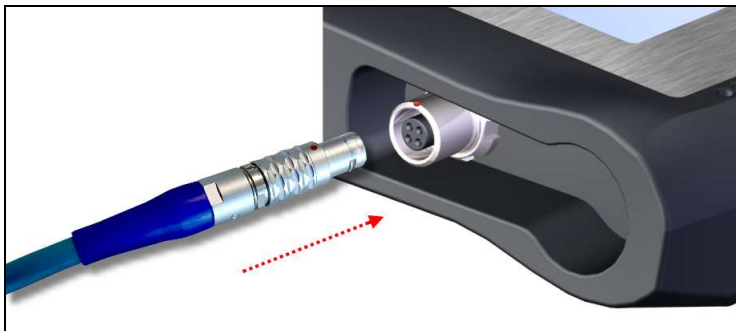

For disconnecting the SD Connect cable, it must be pulled rearwards in the area marked in green. This loosens the snap-in mechanism at the end of the plug.

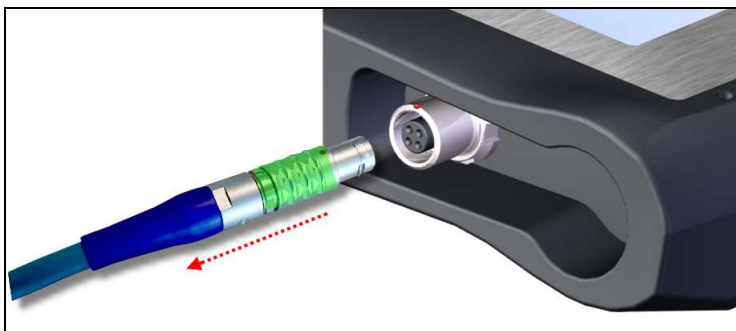

6.5 NETWORK CONNECTION (RJ45)

If the drivers required for functioning are installed on the device, the control system may be integrated in an Ethernet network supporting the 10/100 MBit standard by using the Ethernet 10/100BaseT network connector. Specifications of this network topology must be observed in this case.



PIN NUMBER	SIGNAL NAME
1	TX +
2	TX -
3	RX +
4	NC
5	NC
6	RX -
7	NC
8	NC

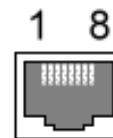

6.6 EXPRESSCARD SLOT

The device is equipped with an ExpressCard slot, which supports the following ExpressCard types.

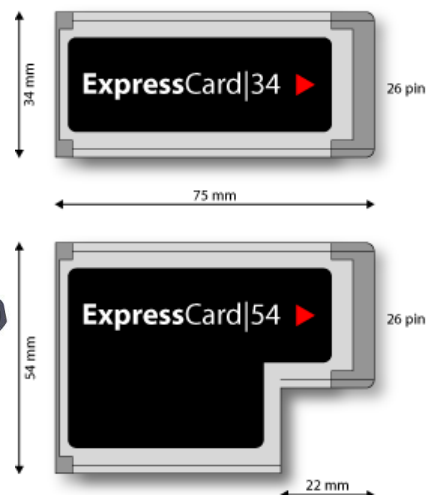

6.7 MIC IN

An external microphone can be connected via the MIC IN socket on the device by means of a 3.5mm cinch cable.



PIN NUMBER	SIGNAL NAME
Ground	GND
R	Signal, right-hand side
L	Signal, left-hand side

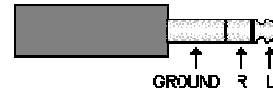

MICROPHONE IN FRONT PANEL

Additionally, the device has an internal microphone in the front panel. This microphone can be configured by using the volume control integrated in the operating system.



6.8 LINE OUT

By using the Line Out socket of this device and connecting via a 3.5mm cinch cable, a stereo audio signal can be output to earphones or to external speakers.



PIN NUMBER	SIGNAL NAME
Ground	GND
R	Signal, right-hand side
L	Signal, left-hand side

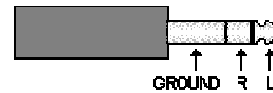

6.9 WLAN

This device is equipped with a radio network card. If the operating system supports this card by corresponding drivers, the device can be integrated in an Ethernet network with support for 11 MBit or 54 MBit (802.11b/g compatible). Specifications of this network topology must be observed in this case.

The device is equipped with a MiniPCI WLAN card including an Atheros chip.

If a device is delivered including operating system by ads-tec, all required device drivers will also be integrated in the system. Under the "Windows XP Professional" and "Windows XP Embedded" operating systems, the original "Atheros Client Utility (ACU)" will also be installed, which can be used for defining new WLAN networks and WLAN connection settings. The mentioned utility offers a large variety of settings, which in most cases will be sufficient for meeting individual network requirements. However, the possibility for making the following settings is lacking:

- Setting the region (e.g. Germany, France, USA, etc.)
- An ad-hoc channel setting, to be specified by region

7 HARDWARE-SPECIFIC SOFTWARE

This device is equipped with specific software tools, which allow monitoring of the operating states.

BATTERY INFORMATION & DIAGNOSTICS TOOL

POWER STATUS

The starting page of the battery information tool gives information about the current accumulator charge status. The lithium-ion accumulators are charged in parallel with the 20V power adapter connected. The charging progress is displayed on the right hand side for both accumulator slots. The status display on the left shows the remaining accumulator charging time.

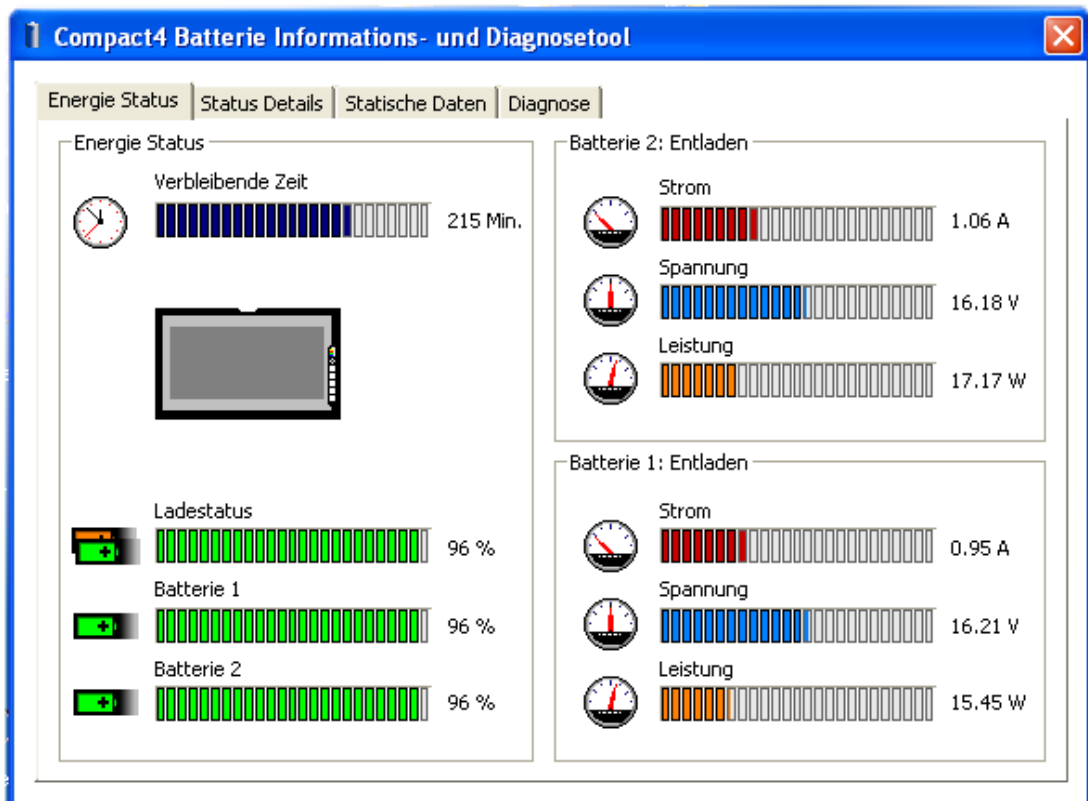

STATUS DETAILS

The Status Detail page lists all starting page data in a table.

	BATTERIE 1	BATTERIE 2
Status	Entladen	Konditionierung
Ladestatus	82 %	3 %
Verbleibende Zeit	85 Min.	0 Min.
Maximale Kapazität	34.28 Wh	33.62 Wh
Kapazität	28.28 Wh	1.02 Wh
Strom	2.02 A	0.00 A
Spannung	15.44 V	16.34 V
Leistung	31.25 W	0.00 W
Temperatur	38° C	38° C
Anzahl der Ladezyklen	0	0

STATIC INFORMATION

The "Static Information" tab displays all detail information, e.g. the manufacturer, and the capacity of the lithium-ion accumulator.

	BATTERIE 1	BATTERIE 2
Eindeutige ID	-	-
Hersteller	-	-
Herstelldatum	-	-
Name	TT13ACCU	TT13ACCU
Seriennummer	-	-
Type	LION	LION
Designkapazität	36.72 Wh	36.72 Wh
Maximale Kapazität	34.28 Wh	33.62 Wh

DIAGNOSTICS

The Diagnostics tab gives information about the proper function and about the number of used lithium-ion accumulators.

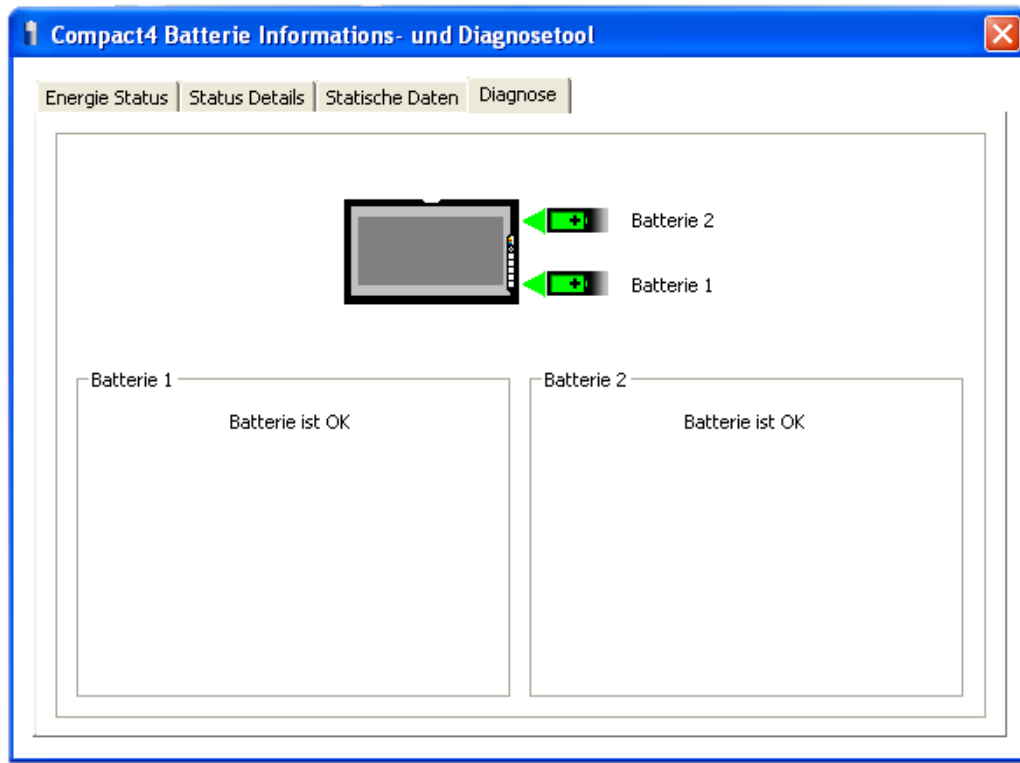

BRIGHTNESS & VOLUME CONTROL

Brightness and volume can be adjusted by using the function keys in the front panel. The function of the front keys is provided by a utility called "**Genkey service**". The actual adjustment of brightness and volume is managed by the "**bvcontrol.exe**" utility. This utility must be active in order to allow setting the brightness and volume by using the keys in the front panel.

FAN CONTROL & INFORMATION TOOL

The Fan control & information tool monitors the function of the fan, as well as the current temperature.

***Warning:***

Malfunction of a fan will be displayed through a popup window.

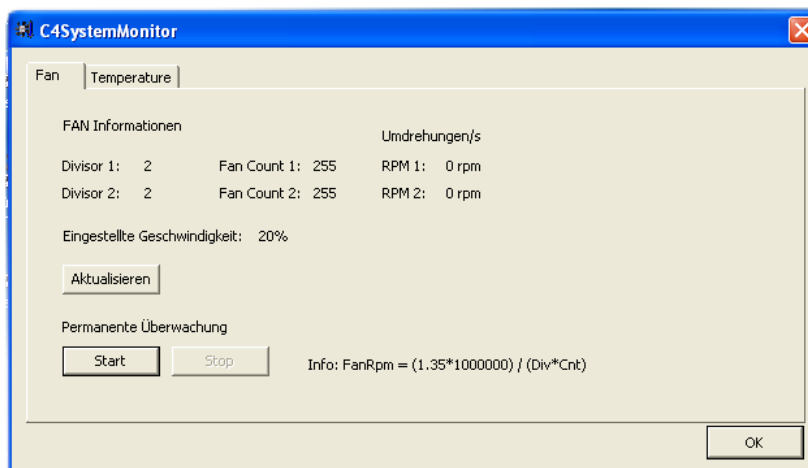
***Note:***

The fan RPM will only be shown if the fan function is active.

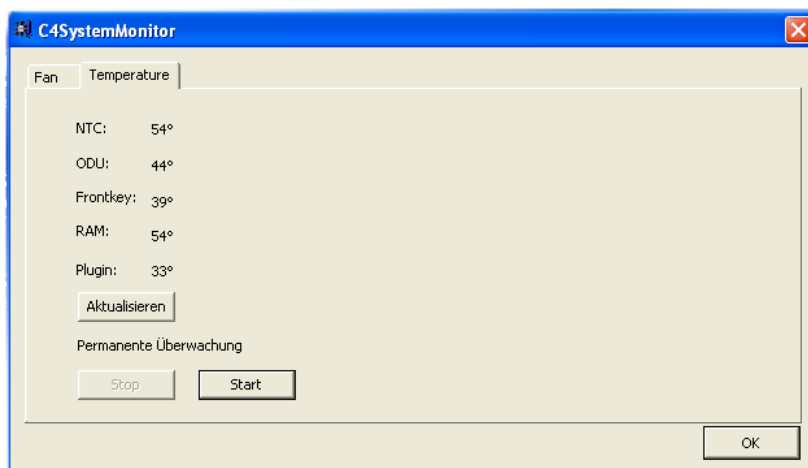

AUTOMATIC FRONT KEYS AND DISPLAY ILLUMINATION

Automatische Fronttasten- und Displaybeleuchtung

-Fronttastenbeleuchtung-

Umschaltwert für die Fronttastenbeleuchtung:

-Hintergrundbeleuchtung-

Automatische Regelung der Hintergrundbeleuchtung aktivieren

Umschaltwert für die Hintergrundbeleuchtung:

Dunkler Wert in [%]:

Heller Wert in [%]:

Schließen Lesen Schreiben

SHOCK SENSOR

ads-tec - TT13ShockSensor

Calibration View



Actual Accelerations:

X: -0.29g Y: 1.29g Z: 0.54g

Protection Sensibility:

Border Vibrations: 65535

Max. Vibrations: 65535

Border HD: 65535

Border Warranty: 65535

Fall detection: 40703

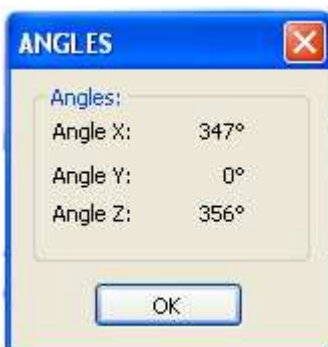
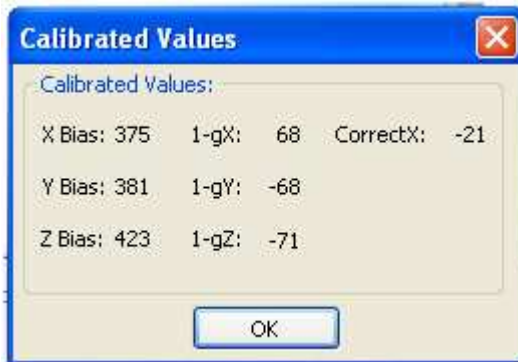

7.1 SOFT KEYBOARD

By using the soft keyboard, data can be entered via the touch screen like with an external keyboard.



Note:

The soft keyboard of the Compact⁴ device can be delivered in 21 languages. Depending on the selected language, the soft keyboard representation and function may vary. Basic functions are identical with all languages. The following languages are available:

German / English (US) / English (UK) / French / Italian / Spanish / Portuguese / Finnish / Turkish / Danish / Swedish / Japanese / Korean / Greek / Czech / Polish / Romanian / Russian / Serbian / Croatian / Hungarian

DEFAULT VIEW:

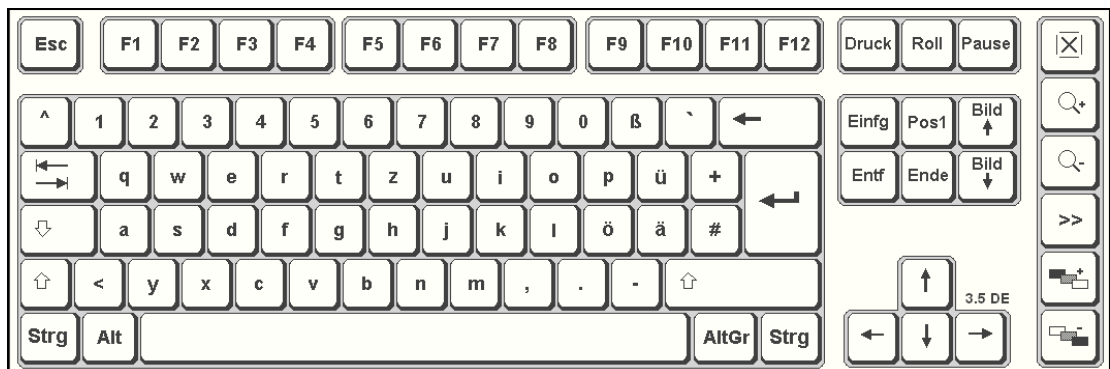

HOW TO OPERATE THE SOFT KEYBOARD FROM VERSION 3.11:



Activate and deactivate the soft keyboard for letter/character input using the touch screen



Deactivate the soft keyboard



Soft keyboard representation, zoom in



Soft keyboard representation, zoom out



Switch to numeric key pad representation



Increase the soft keyboard transparency

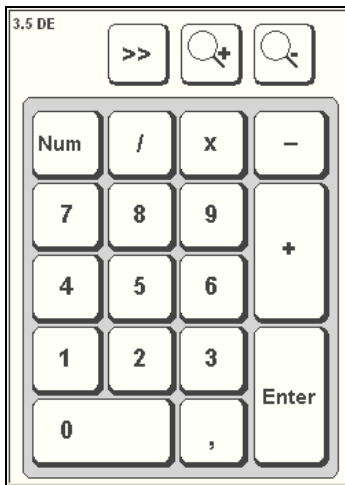

Decrease the soft keyboard transparency

NUMERIC KEY-PAD VIEW:

Switch to representation of the function-key bar

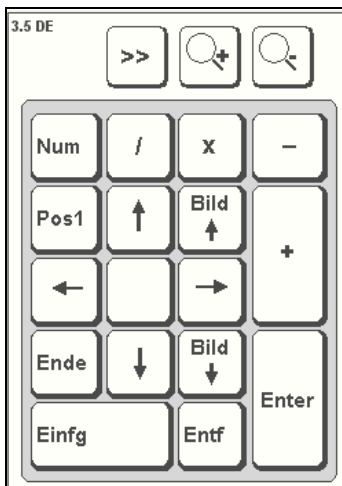
FUNCTION-KEY BAR VIEW:**Note:**

If a function is to be activated, which requires pressing two keys at the same time (e.g. Alt + F4); these keys have to be pushed one after another at the soft keyboard, and the special keys Shift, Alt and Strg must always be pushed first.

Due to differences in programming of a large variety of software, we cannot ensure that the soft keyboard works properly with all software.

When deactivating the soft keyboard, the previously active state (alphanumeric / numeric keys or function keys) will be stored and will be displayed when re-activating the keyboard.

8 ACCESSORIES

8.1 DVD DRIVE / EXTERNAL TYPE



CONNECTION

The DVD drive can be connected to the Compact⁴ device by using the USB interface.

DRIVER INSTALLATION

The required drivers will be installed automatically as soon as the DVD drive is connected with the USB interface.

FUNCTIONS

The Compact⁴ device must be switched on to open the drive. After pushing the Eject button, the drawer jumps open and must be pulled out completely. The CD/DVD is now placed with the opening on top of the centre piece and carefully pushed downwards until the disk holder snaps in. Subsequently the drive must be pushed in.



Note:

The drive can also be opened by using a mechanical ejector without any power supply. In order to do this, you'd have to push with a pointed object into the marked opening until the drawer jumps open.



Note:

The DVD drive is of the slim-line drive type.

8.2 SAFETY OF LASER PRODUCTS

This product has been designed and manufactured according to FDA regulations "title 21.CFR. chapter1, subchapter J.based on the radiation Control for Health and Safety Act of 1968". And is classified as a class 1 laser product. There is no hazardous invisible laser radiation during operation because invisible laser radiation emitted inside of this product is completely confined in the protective housings.

The label required in this regulation is shown bellow.

**Caution:**

Use of controls or adjustments or performance of procedures other than those specified herein may result in hazardous radiation exposure.

Optical pickup

Type : TOP1100S
Manufacturer : TopRay Technologies, Inc
Laser output : Less than 0.5mW on the objective lens
Wavelength : 770-800nm (CD)
645-662nm (DVD)
Standard : IEC60825-1 : 2001

**Caution:**

Class 1M Visible and Invisible Laser Radiation when open. Do not view directly with optical instruments.

Achtung:

Sichtbare und Unsichtbare Laserstrahlung Klasse 1M, wenn Abdeckung geöffnet. Nicht direkt mit Optischen Instrumenten betrachten.

9 REGULATORY APPROVALS

9.1 CERTIFICATIONS / TESTINGS

The Compact 4 system has the following certifications:

CE compatibility (class A)	EN61000-6-2 device complies with standard EN61000-6-4 device complies with standard
UL/cUL201	Application for certification is filed
FCC permission	Application for certification is filed
GOST-R certificate	Application for certification will be filed
MIC certification	Application for certification will be filed
Application for WLAN certificates for 802.11 a/b/g for the	<u>EU countries</u> 2.400 MHz – 2.483,5 MHz 5.150 MHz – 5.350 MHz 5.470 MHz – 5.725 MHz
	<u>Application for certification in USA / Canada</u> 2.400 MHz - 2483,5 MHz 5.150 MHz - 5.350 MHz 5.725 MHz – 5.875 MHz
	<u>Application for certification in Japan</u> 2.400 MHz – 2.483,5 MHz 5.150 MHz – 5.350 MHz 5.470 MHz – 5.725 MHz
	<u>Application for certification in Australia</u> 2.400 MHz – 2.483,5 MHz 5.150 MHz – 5.350 MHz 5.470 MHz – 5.725 MHz



Note:

A respective conformity declaration for the authority in charge is available on request from the manufacturer.

All connected components, as well as cable connections must also meet these requirements for compliance with the EMC legislation. For this reason, screened bus and LAN cables including screened connectors must be used and installed according to the instructions in this user manual.

9.2 ELECTROMAGNETIC COMPATIBILITY (EMC)

Certificate of acceptance in accordance with the Federal Electromagnetic Compatibility Act in Germany ("EMVG") of 2007 (respectively the EMC Directive no. 2004/108/EC).

In accordance with the Federal Electromagnetic Compatibility Act in Germany, this device is authorised to carry the EC conformity sign "CE". Liable party for this conformity declaration is according to para. 5 of the "EMVG" legislation:

ads-tec GmbH
Raiffeisenstrasse 14
D – 70771 Leinfeld – Echterdingen

Information in accordance with "EMVG", para. 3, section (2) 2:

This device complies with the protective requirements according to EN 61000-6-2 and EN 61000-6-4, class A.

Any equipment of class A must be provided with the following warning message: "Warning! - This is equipment of class A. This unit might cause radio interferences in living areas; in this case the operator might be required to take suitable protective measures."

9.3 FCC-APPROVAL

**Note:**

This device complies with Part 15 of the FCC Rules [and with RSS-210 of Industry Canada].

Operation is subject to the following two conditions:

this device may not cause harmful interference, and this device must accept any interference received, including interference that may cause undesired operation.

**Note:**

Changes or modifications made to this equipment not expressly approved by ads-tec GmbH may void the FCC authorization to operate this equipment.

**Note:**

This equipment has been tested and found to comply with the limits for a Class A digital device, pursuant to Part 15 of the FCC Rules. These limits are designed to provide reasonable protection against harmful interference when the equipment is operated in a commercial environment. This equipment generates, uses, and can radiate radio frequency energy and, if not installed and used in accordance with the instruction manual, may cause harmful interference to radio communications. Operation of this equipment in a residential area is likely to cause harmful interference in which case the user will be required to correct the interference at his own expense.

**Note:**

Radiofrequency radiation exposure Information:

This equipment complies with FCC radiation exposure limits set forth for an uncontrolled environment. This equipment should be installed and operated with minimum distance of 0cm between the radiator and your body. This transmitter must not be co-located or operating in conjunction with any other antenna or transmitter.

**Note:**

This Class A digital apparatus complies with Canadian ICES-003.

Cet appareil numérique de la classe A est conforme à la norme NMB-003 du Canada.

10 TECHNICAL DETAILS

10.1 DISPLAY DATA

Display	13.3" TFT, WXGA 1280 x 800 pixels
Display colours	262,144 colours
Brightness	200 cd/m ² at max (adjustable)
Touch screen	Resistive 5-wire touch screen
Contrast	400:1

10.2 COMPUTER DATA

Processor	Intel Pentium M Yonah ULV 1.06GHz Core Solo 423 (5.5W)
RAM	2GB DDR2 SODIMM PC2-5300
Chip set	Intel 855 GME
Graphic memory	A maximum of 64 MB, shared memory
Mass storage device	2.5" SATA 120 GB hard disk
Interfaces	at the base device: 3 x USB 2.0 (1 of which is recessed for flash memory stick) at the multifunction unit: 1x COM (SUB-D), 3x USB 2.0, 1x MIL
Network	1x Ethernet (10/100 MBit) RJ 45, 1x Ethernet (10/100 MBit) via SD connector
Wireless	WLAN, 802.11 b/g
Slots	1x Express card, wide slot
Sound	2x speakers, 1x microphone, 1x headphone out, 1x microphone in
Power supply	20V DC +/- 20%
Accumulator	Li-Ion smart-battery accumulator with 14.4V and 32Wh, 2 accumulator slots

10.3 GENERAL DATA

External dimensions	355 mm x 261 mm x 41 mm (W x H x D)
Weight	approx. 3.0 kg
Protection class	IP 54
Power consumption	24 Watts (typical)
Max. switch-on current	7 Amperes (for 2ms)

1 1 SERVICE AND SUPPORT

ads-tec and appointed partner companies offer you comprehensive maintenance and support services, ensuring quick and competent support should you have any questions or concerns with regard to ads-tec products and equipment.

ads-tec products may also be provided and installed by partner companies. Such devices may have customised configurations. Should any questions arise with regard to such specific settings and software installations, please contact the system supplier in question as ads-tec will not be able to reply to such questions.

ads-tec does not provide support services for any device or unit that was not bought directly from ads-tec. In any such case, maintenance and support is provided solely by the partner company that supplied the device or unit.

11.1 ADS-TEC SUPPORT

The ads-tec support team is available for inquiries by direct customers between 8:30am and 5:00pm, Monday to Friday. The support team can be reached via phone, fax or email.

Tel: +49 (0) 711 / 45894-500

Fax: +49 (0) 711 / 45894-990

Email: info@ads-tec.com

11.2 COMPANY ADDRESS

ads-tec
Automation Daten- und Systemtechnik GmbH
Raiffeisenstraße 14
70771 Leinfelden-Echterdingen
Germany

Tel: +49 (0) 711 / 45894-0

Fax: +49 (0) 711 / 45894-990

Email: info@ads-tec.de

Web: www.ads-tec.de