



User Manual (Part 2)

Speakerphone/ Answering System 1855

with Caller ID & Call Waiting



For customer service or product information, visit our web site at **www.telephones.att.com** or call 1-800-222-3111.

Please also read ***Important Product Information***
Enclosed in product package.

User Manual (Part 2)
**Speakerphone/
Answering System
1855**



Table of contents

Getting Started

- Quick reference guide2
- Parts checklist.....3
- Before you begin4
- Telephone installation5
- Wall mounting6

Telephone Operation

- Basic operation8
- Options while on calls9
- Feature menu10

Memory Dialing

- One touch dialing12
- Speed dialing12
- Entering numbers.....13

Caller ID Log

- How Caller ID works14
- To review your call log.....15
- To dial a call log entry16

Answering System Operation

- Answering system operation17
- Day and time announcements18
- Outgoing announcements.....19
- Announce Only mode20
- Changing feature options.....21
- Message playback22
- Recording and playing memos23
- Message window displays.....24
- Remote access.....25

Appendix

- Icons, tones & indicator lights.....26
- In case of difficulty27
- INDEX.....29

Getting Started

Quick reference guide

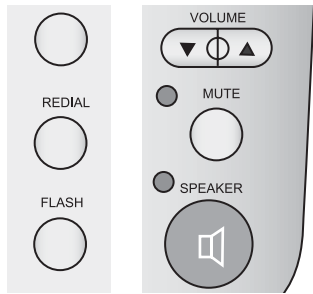
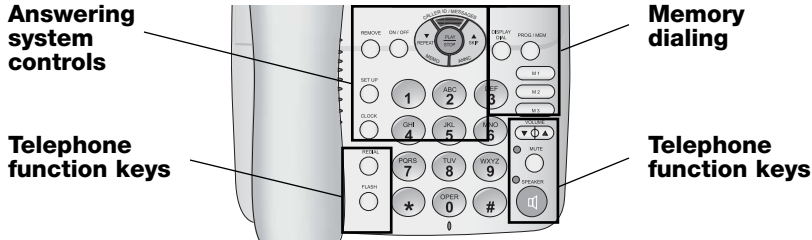

Telephone function keys (see pages 8-9)

- REDIAL**Press to redial last number called.
- FLASH**During a call, press to receive an incoming call, if you subscribe to a Call Waiting service.
- VOLUME**Press to adjust volume of ringer or active call.
- MUTE**Press to silence microphone; press again to resume.
- SPEAKER**Press to turn speakerphone on or off (begin or end a call).



Answering system controls (see pages 17-24)

Repeat message, record memo or change menu settings.  Skip to next message, record announcement or change menu settings.

Press to play or stop playing messages.
Press and hold to play old messages.

- REMOVE**Press to delete message currently playing.
- ON/OFF**Press to turn answering system on or off.
- SETUP**Press to review, press and hold to change answering system options.
- CLOCK**.....Press to review, press and hold to set the day and time.

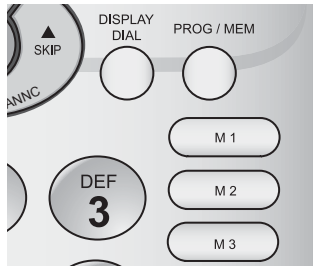

Memory dialing (see pages 12-13)

- DISPLAY DIAL**.....Press and then lift handset (or press **SPEAKER**) to dial number displayed on screen.
- PROG/MEM**Press to program or dial a number in Speed Dial memory.
- M1-M3**Press to dial a One Touch Dialing number.
 (See pg 13 in User Manual for memory programming instructions).

Getting Started

Parts checklist

Remember to save your sales receipt and original packaging in case you ever need to ship your telephone for warranty service. Check to make sure the telephone package includes the following:



Telephone handset

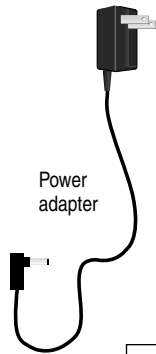

Power adapter

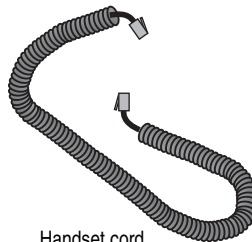

Handset cord



Telephone



Telephone line cord

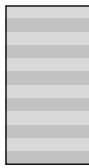

Directory card



Quick Start Guide

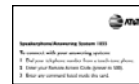

Wallet card

Getting Started

Before you begin

About Caller Identification

Caller ID with Call Waiting features in this telephone let you see who's calling before you answer the phone, even when you're on another call. These features require services provided by your local telephone company.

Contact your telephone service provider if:

- You have both Caller ID and Call Waiting, but as separate services (you may need combined service)
- You have only Caller ID service, or only Call Waiting service
- You don't subscribe to any Caller ID or Call Waiting services.

You can use this phone with regular Caller ID service, and you can use its other features without subscribing to either Caller ID or combined Caller ID with Call Waiting service. There may be fees for these services, and they may not be available in all areas.

Caller ID features will work only if both you and the caller are in areas offering Caller ID service, and if both telephone companies use compatible equipment.

See Caller ID Operation, beginning on page 14, for more details about how these features work.

Getting Started

Telephone installation

Install the telephone as shown below. Choose a location where the phone is not exposed to excessive heat, cold, dust or moisture.

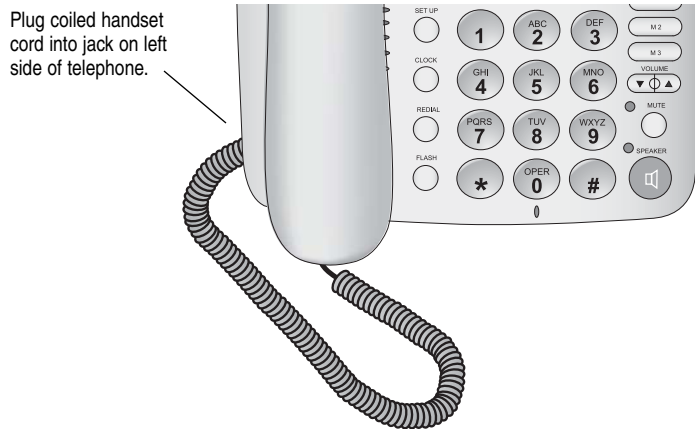
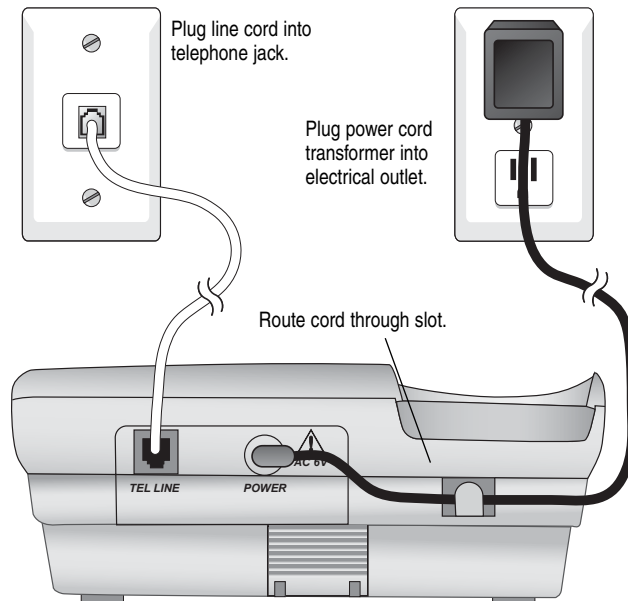

NOTE: Use only the power cord supplied with this product. If you need a replacement, call 1 800 222-3111.

Be sure to use an electrical outlet not controlled by a wall switch.

Getting Started

Wall mounting

The telephone can be installed on any standard wall-phone outlet. Choose a location where the phone is not exposed to excessive heat, cold, dust or moisture.

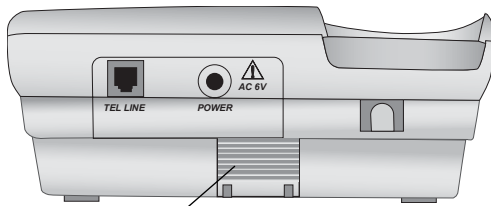

Press and pull to remove wall-mount bracket.

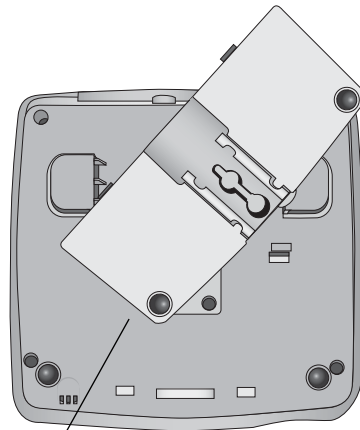
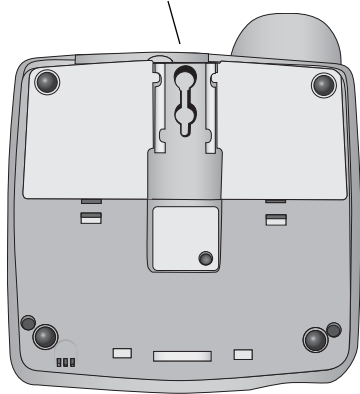

Turn bracket upside down.

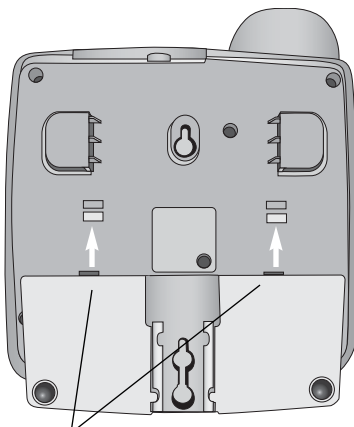

Insert bracket tabs into lower notches.

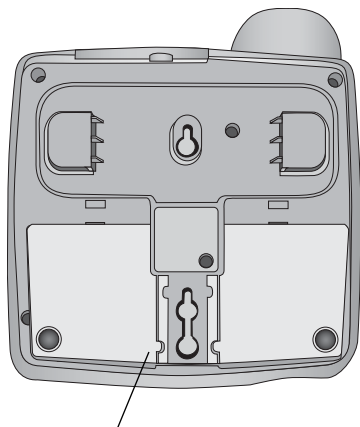

Press down firmly to click in place.

Getting Started

Wall mounting

Plug line cord into telephone, then wrap cord around posts as shown below. Leave a few inches free, enough to route wire under tabs and plug into the wall jack.

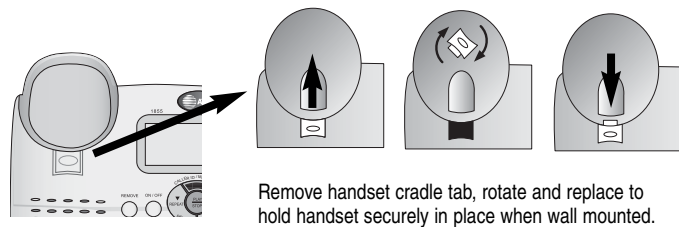
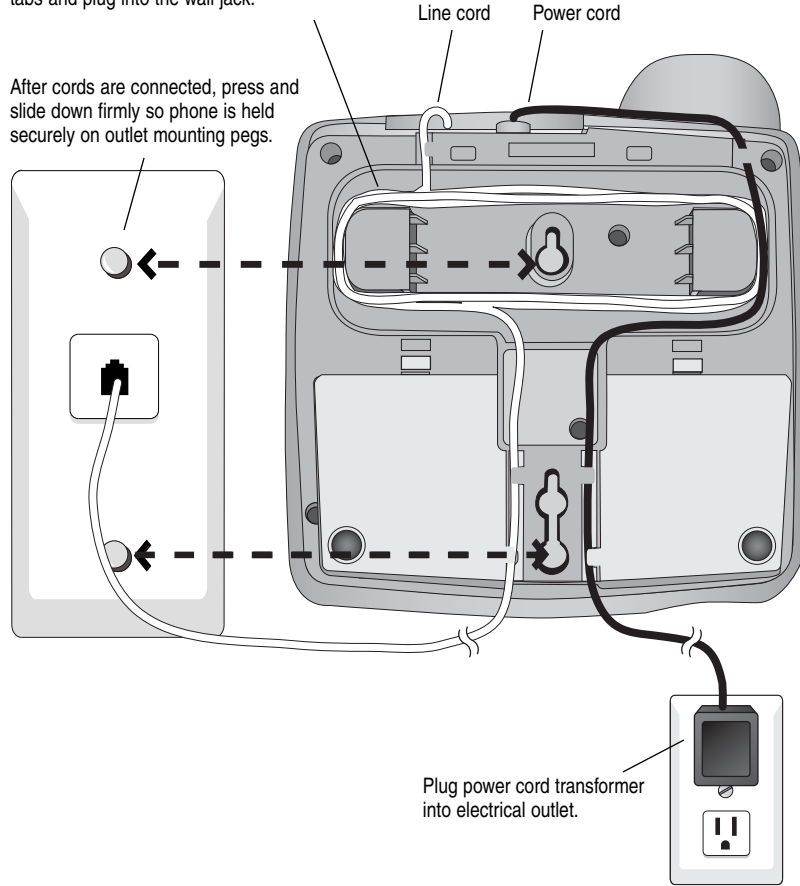



Telephone Operation

Basic operation

Making and answering calls

To answer a call, lift the handset, or press **SPEAKER** to use the speakerphone.

To make a call, lift the handset (or press **SPEAKER**), then dial a number. Replace the handset (or press **SPEAKER**) to hang up.

Hands-free speakerphone calls

To answer an incoming call, press **SPEAKER**. To make a call, press **SPEAKER**, then dial a number. When the handset is out of the cradle you can press **SPEAKER** to toggle between hands-free speakerphone and normal handset use. Press **SPEAKER** again to hang up.

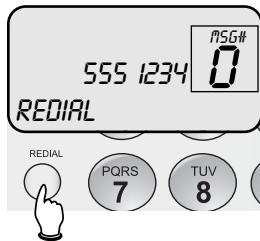

Last number redial

The most recently dialed number is displayed when you lift the handset or press **SPEAKER**. Press **REDIAL** to dial it again.

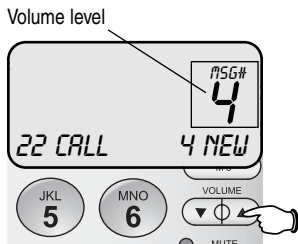

To adjust ringer volume

To adjust the ringing volume, press the **VOLUME** buttons while the phone is idle. Each button press raises or lowers the ringer volume by one level. You can turn the ringer off, or select one of seven volume levels.

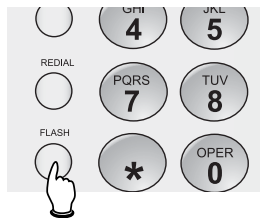
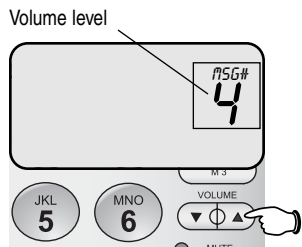

Light is on when phone is muted



Telephone Operation

Options while on calls

To adjust listening volume

Press the **VOLUME** buttons to adjust listening volume.

There are eight volume levels for the speakerphone, and four levels for the handset. Each button press raises or lowers listening volume by one level.

Call waiting

If you have Call Waiting service, you will hear a beep if someone calls while you are already on a call. Press **FLASH** to put your current call on hold and take the new call. You can press **FLASH** at any time to switch back and forth between calls.

Mute

Press **MUTE** to silence the microphone during a call. You will be able to hear, but your caller will not be able to hear you until you press **MUTE** again to resume your conversation.

Turn off answering system
(red light off)

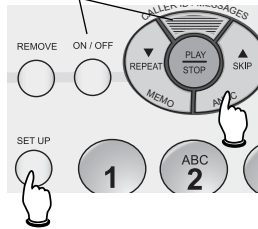

Press **SET UP** to select feature.
Press **SKIP/REPEAT** to change.
Press **SET UP** to save.

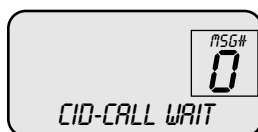

Telephone Operation

Feature menu

In the feature menu you can customize how the telephone works. Make sure the answering system is off (red light off), then press **SET UP** repeatedly until the feature you want is displayed. Press **SKIP/REPEAT** to change settings. Press **SET UP** again to accept the new setting and move to the next feature.

Contrast

Press **SKIP/REPEAT** to adjust screen contrast to maximize readability in different lighting conditions. There are five contrast levels (1-5).

Call history

Press **SKIP/REPEAT** to turn the Caller ID log on or off:

- All Calls: Each incoming call is logged.
- No Calls: No Caller ID information is kept.

Repeated calls

The Caller ID log notifies you when multiple calls are received from the same number. Press **SKIP/REPEAT** to turn this feature on or off:

- Combined: Only the most recent call from each number is kept. A "REP" icon is displayed if more than one call is received from the same number.
- Separate: Each call is logged, even if the same person calls more than once.

Call waiting

When on, the telephone displays and logs Caller ID information if you get a new incoming call while on an existing call. Press **SKIP/REPEAT** to turn this feature on or off.

*Telephone Operation***Feature menu****Language**

Press **SKIP/REPEAT** to select the language used in all menus and screen displays. You can choose English, Espanol or Francais.

Home area code/Local area codes

Caller ID numbers are not always displayed in the correct dialing format. To make callbacks easier, you can enter your home area code so that it is not included when a number is displayed or dialed.

You can also enter up to 4 local area codes for areas nearby. When you receive a call from one of these areas, the local area code is automatically included when the number is displayed or dialed.

Use the keypad to enter your home area code, then press **SET UP** to enter up to 4 other area codes if desired.

When you dial a Caller ID entry:

- Calls from your designated home area code will be dialed out using 7 digits, without the area code (i.e., 555-1234)
- Calls from your designated local area codes will be dialed out using 10 digits, with the area code included (i.e., 818-555-1234).

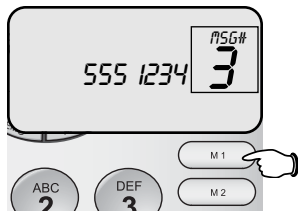

Memory dialing

Memory capacity

The telephone can store up to 12 numbers in memory locations for quick dialing. Each memory location can store a number up to 24 digits long.

One touch dialing (M1-M3)

To dial numbers stored in One Touch buttons, lift the handset (or press **SPEAKER**), then press a One Touch button (**M1, M2, M3**).

Speed dialing (1-9)

To dial numbers in Speed Dialing memory locations:

- 1 Lift the handset (or press **SPEAKER**).
- 2 Press **PROG/MEM**.
- 3 Press a digit to dial the location you want (**1-9**).

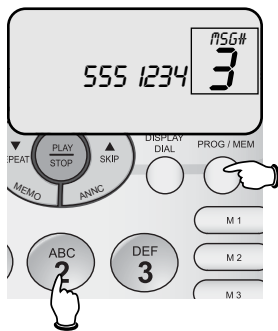

Directory card

The directory card provided with your telephone can be used to record names or numbers stored in memory locations. The back peels off to expose an adhesive surface so you can attach it to the underside of the handset if desired.

Directory card



i **NOTE:** If you pause for too long while programming a memory location, the procedure will time out and you will have to begin again.

i **NOTE:** If you store a number in a memory location that is already in use, the old number will be overwritten with the new number.

Press **PROG/MEM**, then enter number

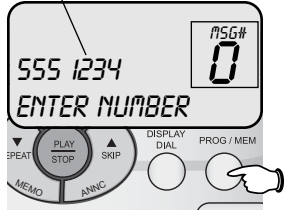

Press **PROG/MEM**, then press button (M1-M3) or enter location (1-9)

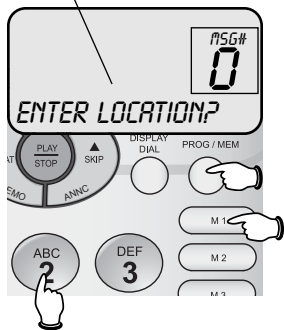

Repeat to enter another number, or press **REMOVE** to exit.



Memory Dialing

Entering numbers

One touch dialing (M1-M3)

To program One Touch buttons:

- 1 Press **PROG/MEM**.
- 2 Enter a telephone number (up to 24 digits), or import one by pressing **REDIAL** or **REPEAT/MEMO**.
- 3 Press **PROG/MEM**.
- 4 Press a One Touch button (**M1**, **M2**, **M3**).
- 5 Repeat steps 2-4 to program another button, or press **REMOVE** to save and exit.

Speed dialing (1-9)

To program Speed Dialing memory locations:

- 1 Press **PROG/MEM**.
- 2 Enter a telephone number (up to 24 digits), or import one by pressing **REDIAL** or **REPEAT/MEMO**.
- 3 Press **PROG/MEM**.
- 4 Press a digit to select the location you want (**1-9**).
- 5 Repeat steps 2-4 to program another memory location, or press **REMOVE** to save and exit.

Options while entering numbers

- Press **SKIP** to erase numbers if you make a mistake.
- Press **REPEAT** twice to enter a 3-second dialing pause.
- Press **REMOVE** to exit without saving the number.

To change numbers

To change a number, follow the steps above to enter another number in its place.

Caller ID Log

How Caller ID works

If you subscribe to Caller ID service provided by your local phone company, information about each caller will be displayed after the first or second ring.

Information about the last 50 incoming calls is stored in your call log. You can review the call to find out who has called, or return the call without dialing.

If you answer a call before the information appears on the screen, it will not be saved in your call log.



Light on: New call(s) received

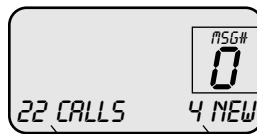
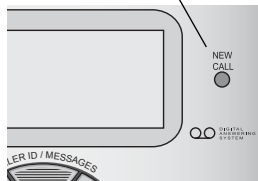

Total calls

New (unviewed) calls

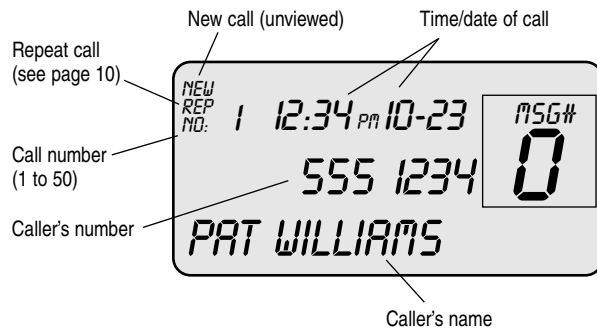

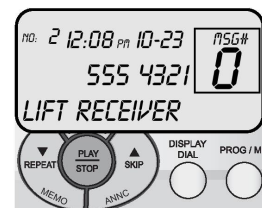
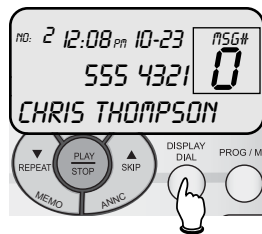
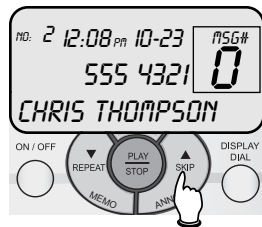
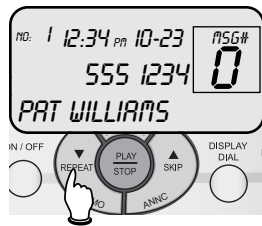

Caller ID Log

To review your call log

To review your Caller ID log

Press **REPEAT/MEMO** to display the most recent call.

Press **SKIP/ANNC** repeatedly to scroll through the list of earlier calls, or press **REPEAT/MEMO** to scroll back to more recent calls.

To return a call

To dial a number that is currently displayed, press **DISPLAY DIAL** and then lift the handset (or press **SPEAKER**) (See page 16 for important dialing options.) If you forget to lift the handset or press **SPEAKER** the display will remind you to do so by displaying "LIFT RECEIVER".

To copy an entry into memory

To copy any displayed number (see page 16 for important dialing options) into memory, press **PROG /MEM**. The name and time will be removed, and the telephone number will remain in the display. Press **PROG/MEM** again. "ENTER LOCATION?" will appear in the display. Enter a memory location number (1-9).

To delete entries

Press **REMOVE** to delete the displayed entry from your Caller ID log. Press and hold **REMOVE** to delete all entries, then press **REMOVE** again to confirm.

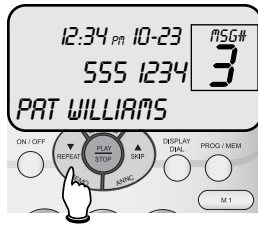

Note: You can also remove the area code or add a preceding "1" before programming a number into memory by pressing **SETUP** once, and **ANNC** repeatedly, until you see the correct option.

Caller ID Log

To dial a call log entry

To call a number that is currently displayed, press **DISPLAY DIAL**, then lift the handset (or press **SPEAKER**).

Dialing options

Caller ID numbers may appear with an area code that may not be required for local calls. If the number displayed is not in the correct format, you can change how it is dialed.

While the number is displayed, press **SET UP**, then press **ANNC** repeatedly to see various dialing options (with or without area code, with or without preceding "1").

When the option you want is displayed, press **DISPLAY DIAL** and then lift the handset (or press **SPEAKER**).

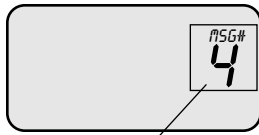

Message counter

Number of messages recorded (or, during playback, message number currently playing).

Answering System Operation

Answering System Operation

Message capacity

The answering system can record up to 99 messages, depending on how long each message is. Individual messages can be up to 3 minutes long, but total maximum recording time is 19 minutes. Messages will remain available for replay until you delete them.

Press to repeat message; hold while listening to slow down playback (see page 22).

Press and hold to record memo (see page 23).

Press to start or stop message playback (see page 22).

Press to skip message; hold while listening to speed up playback (see page 22).

Press and hold record outgoing announcement (see page 19).

Press to turn answering system on or off.

Press to delete message (see page 22).

Press to hear feature options. Hold to change options (see page 21).

Press to hear day/time. Hold to set day/time (see page 18).

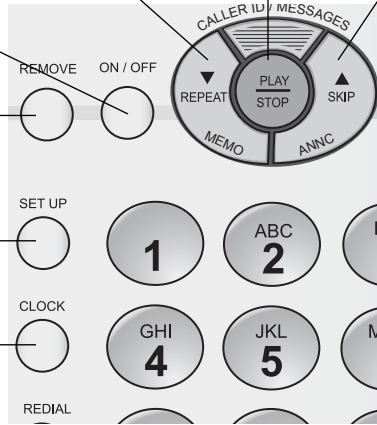

NOTE: The answering system must be on to review or change settings.

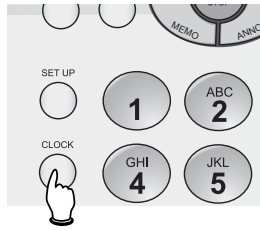
**1** **CLOCK**

"Sunday"

2 **SKIP/REPEAT**

"Monday"

Press until correct day is spoken.

3 **CLOCK**

"12 PM"

4 **SKIP/REPEAT**

"1 PM"

Press until correct hour is spoken.

5 **CLOCK**

"0"

6 **SKIP/REPEAT**

"1"

Press until correct minute is spoken.

7 **CLOCK**

"2004"

8 **SKIP/REPEAT**

"2005"

Press until correct year is spoken.

9 **CLOCK**

"Monday, 1 pm, 2005"

*Answering System Operation***Day and time announcements****To set day and time**

Before playing each message, the answering system announces the day and time the message was received.

Before using the answering system, you should follow the steps at left to set the day and time, so messages are dated correctly.

To begin, press and hold the **CLOCK** button for 2 seconds.

The system uses voice prompts to guide you.

Each time you press **SKIP**, the day, hour, minute or year advances by one. Each time you press **REPEAT**, the day, hour, minute or year is reduced by one. When you hear the correct setting, press **CLOCK** to move to the next setting.

To check day and time

You can press **CLOCK** at any time to hear the current day and time without changing it.



NOTE: The answering system must be on to review or change settings.

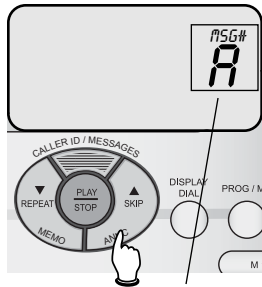

Press and hold **SKIP/ANNC**.
Begin speaking when "A"
appears in message window.

Release button to stop recording.

Speak into microphone.



Microphone ↑

Answering System Operation

Outgoing announcements

The outgoing announcement is what callers hear when calls are answered by the answering system.

The phone is pre-programmed to answer calls with **"Hello. Please leave a message after the tone."** You can use this announcement, or replace it with a recording of your own voice.

To record your outgoing announcement

Press and hold **SKIP/ANNC**. Begin speaking when "A" appears in the message window. To stop recording, release the button. The message just recorded will be played back.

Speak facing the telephone from about 9 inches away. You can record an announcement up to 3 minutes long. Announcements less than 3 seconds long will not be recorded.

To review your outgoing announcement

Press **PROG/MEM**, then **SKIP/ANNC** to hear the currently used outgoing announcement.

To delete your outgoing announcement

Press **PROG/MEM**, then **SKIP/ANNC** to hear the currently used outgoing announcement. Press **REMOVE** during playback to delete your announcement.

When your announcement is deleted, calls will be answered with the pre-programmed announcement described above.



"AO" (Announce Only) stops flashing after an announcement is recorded.

1 SET UP

Press and hold for 1 second to enter feature menu.

 "Selected announcement is A"

2 SKIP/REPEAT

 "Announce Only"

3 PLAY/STOP

Answering System Operation

Announce Only mode

In Announce Only mode, callers hear an announcement but cannot leave messages. This option is useful, for example, to notify callers that you will be away for an extended period and request that they call back after a certain date.

To turn Announce Only on or off

Press and hold **SET UP** until you hear "**Selected announcement is A**". Then press **SKIP/REPEAT** until you hear the option you want:

- **A**: Callers hear current outgoing announcement and can leave messages.
- **Announce Only**: Callers hear current outgoing announcement and cannot leave messages.

Press **PLAY/STOP** to save your selection and exit, or press **SET UP** again to change other features (see page 21).

To record your outgoing announcement

After turning on the Announce Only feature, follow the procedure on page 19 to record your announcement.

If you do not record an announcement, incoming calls will be answered after 10 rings, but callers will hear "**No Announcement**" and will not be able to leave a message.

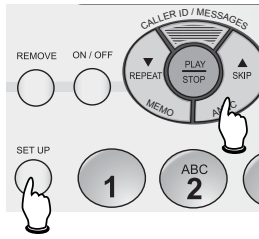

1 SET UP

Press and hold for 1 second to enter feature menu.

2 SET UP

Press until desired feature is heard (see list at right).

3 SKIP/REPEAT

Press until desired selection is heard.

4 SET UP

Press to set selection and move to next menu option.

Or

PLAY/STOP

Press to set selection and exit menu.

What is Priority Call Code?

If a caller enters your Priority Call Code while your announcement is playing, you'll be alerted with a special tone so you can answer the call.

The code is pre-set to 999. See steps at right to change it.

Answering System Operation

Changing feature options

When the answering system is on, you can customize how the system operates. Press and hold SET UP to begin, then press repeatedly to hear each feature. Press **SKIP/REPEAT** to change the setting of any feature.

Feature options (Default settings underlined)

System announces:	Feature description:
"Selected announcement is..." Options: <u>A</u> / Announce Only	A: Callers can leave messages. Announce Only: Callers cannot leave messages (see page 19).
"Number of rings is..." Options: 2-7 / <u>24</u> / 46 (default <u>4</u>)	Choose number of rings before the system answers a call (2 to 7). There are two toll-saver options: 2/4 (2 rings if new messages, 4 otherwise) and 4/6 (4 rings if new messages, 6 otherwise).
"Message alert is..." Options: On / <u>Off</u>	When on, the telephone beeps every 15 seconds when you have new messages.
"Remote access code is..." Options: 500-999 / (default <u>500</u>)	Follow prompts to enter a 3-digit number (must be between 500 and 999).
"Priority call code is..." Options: 500-999 / (default <u>999</u>)	A special tone alerts you when callers enter this code (must be 500-999).
"Announcement monitor is..." Options: <u>On</u> / Off	When on, you will hear your outgoing announcement as callers hear it.
"Number announce is..." Options: On / <u>Off</u>	When on, you will hear Caller ID number spoken when a call is received.
"Store number is..." Options: On / <u>Off</u>	When on, you will hear caller's phone number spoken before message playback.
"Accept blocked calls is..." Options: <u>On</u> / Off	When on, the telephone will accept calls from callers with blocked Caller ID.
"Call screening is..." Options: <u>On</u> / Off	When on, you can hear callers as they leave messages.
"Selected ring is..." Options: Ring style <u>1-4</u>	Press SKIP/REPEAT to hear and select one of four different ringing styles.

Number of messages
(or, during playback, message
number currently playing).

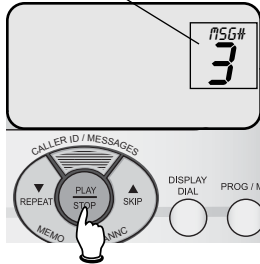

Press **PLAY/STOP** to begin or
end message playback.

1 **PLAY/STOP**

Message playback begins. See
options at right.

2 **PLAY/STOP**

Message playback ends.

 **NOTE:** If "F" is flashing in
the message window, memory is
full. You will have to delete some
messages before new ones can
be received.

 **NOTE:** If you have new
(unheard) messages, the "Delete
All" feature will not work.

Answering System Operation

Message playback

Press **PLAY/STOP** to hear only new (unheard) messages.
Press and hold **PLAY/STOP** to hear all messages.

If you have new messages waiting, you will hear only the
new messages (oldest first).

Announcements

- Before each message, you will hear the day and time
it was received.
- After the last message, you will hear "End of messages."
If the system has less than 5 minutes of recording
time left, you will hear time remaining.

Options during playback

- Press **VOLUME** button to adjust speaker volume.
- Press **SKIP** to skip to next message (or hold down
to speed up message playback).
- Press **REPEAT** to repeat message currently playing.
Press twice to hear previous message. (Hold down
to slow down message playback).
- Press **REMOVE** to delete message being played back.
- Press **PLAY/STOP** to stop playback.

To delete all messages

To delete all messages, press and hold **REMOVE** while
the phone is idle (not during a call, or during message
playback).

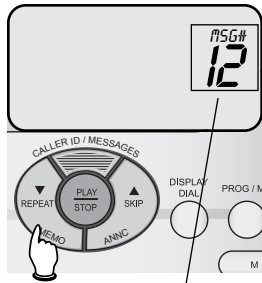

Press and hold **REPEAT/MEMO**, then begin speaking. Elapsed time is shown in message window.

Press **PLAY/STOP** to stop recording.

Speak into microphone.



Microphone ↑

Answering System Operation

Recording and playing memos

Memos are messages you record yourself. They are saved, played back and deleted exactly like incoming messages. You can record a memo as a reminder to yourself, or leave a message for someone else if others in your household use the answering system.

To record a memo

Follow the steps at left to record a memo. Elapsed time (in seconds) is shown in the message window as you record. You can record a memo up to 3 minutes long.

To play back a memo

Press **PLAY/STOP** to hear messages and memos (see page 22 for other options).

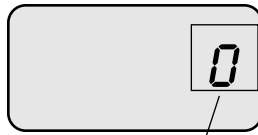

Message window

Answering System Operation

Message window displays

The message window usually displays the total number of memos and incoming messages. See the list below for explanations of other displays in this window.

Message window displays

0	No messages waiting.
1-99	Number of messages/memos, or message currently playing (see page 22).
71 72 73	Current Remote Access Code while setting (see page 21).
0-7 / 1-8	Current ringer volume/listening volume level while adjusting.
0-59 (counting)	Elapsed time while recording a memo (see page 23) or announcement (see page 19).
F (flashing)	Memory is full. Messages must be deleted before new messages can be received.
CL (flashing)	Clock needs to be set (see page 18).
RD	Announce Only mode is on. If flashing, no announcement has been recorded (see page 19).
--	System is answering a call, or being accessed remotely.
-- (flashing)	System is being programmed or initialized.
- - (on) (off)	Displayed for 1 second when any answering system setting is turned on or off.
FS	Displayed during feature setting review.

A 3-digit security code is required to access your answering system from any touch-tone phone. This code is "500" by default; see page 21 to change it.

- 1 Dial your telephone number from any touch-tone phone.
- 2 When system answers, enter your 3-digit Remote Access Code (500 unless you have changed it).
- 3 Enter remote commands (see list at right).
- 4 Hang up to end call and save all undeleted messages.

The system uses voice prompts to help you set the day, hour and minute, and year.

- 1 Press * 8. You will hear the current day, and, "to change, press 6 or 4."
- 2 Press 4 repeatedly to advance or press 6 repeatedly to reduce the value of the setting.
- 3 When you hear the correct value for the day, (or hour, or minute, or year,) press 8 to move to the next time setting.
- 4 Repeat steps 2 and 3 to change each time setting. When finished, the system will announce the new day, hour, minute, and year.

Answering System Operation

Remote access

Play messages



Press 1 to hear all messages.
Press 2 to hear only new messages.

Repeat or go back



Press to repeat current message. Press 4 twice (4 4) to hear previous message.

Skip message



Press to skip to next message.

Stop



Press to stop any operation (stop playback, stop recording).

Delete message



Press 3 to delete message during playback. Press 33 to delete all messages.

Review announcement



Press to review current outgoing announcement.

Record announcement

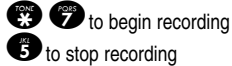

Press * 7, wait for beep, then begin speaking. Press 5 to stop recording and hear playback of new announcement.

Record memo

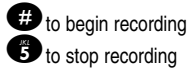

Press #, wait for beep, then begin speaking. Press 5 to stop recording.

Turn system on



If off, system will answer after 10 rings. Enter your access code, then press 0 to turn on.

Turn system off



Review/set day & time



Press 8 to hear current day & time. Press * 8 to change day & time. Follow the steps at left to set the day and time.

Review settings



Press to hear current status of all answering system settings.

Exit



Press to hang up answering system.

Appendix

Icons, tones & indicator lights





Status icons

-  Ringer is off (see page 8).
- NEW** New call received (see page 14).
- REP** Repeat call from same number (see page 14).
- No.** Call number (see page 14).
- ERR** Error (current operation has been unsuccessful; try again).
- MSG#** Message number (see page 17).
- CL** If flashing, set answering system clock (see page 18).



Alert tones

-  **"Beep"** (1 quick beep) Confirmation tone (procedure completed).
-  **"Beep-Beep-Beep-Beep-Beep"** (5 quick beeps) Error tone (current operation has been unsuccessful; try again).
-  **"Beep-Beep-Beep"** (3 quick beeps, repeated) Priority call alert (caller has entered priority call code; see page 21).

Indicator lights



- NEW CALL**
On when new call(s) received since Caller ID log last reviewed.
- ANSWERING SYSTEM**
On: Answering system is on.
Off: Answering system is off.
Flashing: New message(s) received
- MUTE**
On when microphone is muted.
- SPEAKER**
On when speakerphone is in use.

Appendix

In case of difficulty

If you have difficulty with your phone, please try the suggestions below. For Customer Service, visit our web site at www.telephones.att.com, or call 1 800 222-3111.

Telephone does not work at all

- Make sure the AC adapter is plugged into an outlet not controlled by a wall switch.
- Make sure the line cord is plugged firmly into the telephone and the modular jack (see page 5).

Telephone does not ring

- Make sure the ringer is on (see page 8).
- Make sure the telephone line cord and AC adapter are plugged in properly (see page 5).
- You might have too many extension phones on your telephone line to allow all of them to ring. Try unplugging some of them.

If you hear noise or interference during a call

- Appliances plugged into the same circuit as the telephone can cause interference. Try moving the appliance or telephone to another outlet.
- Disconnect the telephone from the modular jack and connect another telephone. If calls are still not clear, the problem is probably in your wiring or local service. Call your local telephone service company.

*Appendix***In case of difficulty****Incomplete messages**

- If a caller leaves a very long message, part of it may be lost when the system disconnects the call after 3 minutes.
- If the caller pauses for more than 7 seconds, the system stops recording and disconnects the call.
- If the system's memory becomes full during a message, the system stops recording and disconnects the call.

Difficulty hearing messages

- Increase speaker volume.

System does not answer after correct number of rings

- Make sure that the answering system is on.
- If Toll Saver is activated, the number of rings changes when you have new messages waiting (see page 21).
- In some cases, the system may be affected by the ringing system used by the local telephone company.
- If the memory is full or the system is off, the system will answer after 10 rings.

"CL" flashes in message window

- You need to reset the answering system clock (see page 18).

System does not respond to remote commands

- Make sure to enter your Remote Access Code correctly (see page 25).
- Make sure you are calling from a touch-tone phone. When you dial a number, you should hear tones. If you hear clicks, the phone is not a touch-tone telephone and cannot activate the answering system.
- The answering system may not detect the Remote Access Code while your announcement is playing. Try waiting until the announcement is over before entering the code.
- There may be noise or interference on the phone line you are using. Press dial-pad buttons firmly.

Announcement message is not clear

- When you record your announcement, make sure you speak in a normal tone of voice, about 9 inches from the telephone.
- Make sure there is no "background" noise (TV, music, etc.) while you are recording.
- Record your outgoing announcement from a remote telephone (see page 25).

Appendix

Index**A**

AC adapter, 5, 7
 Access code, 25
 Alert tones, 26
 Answering calls, 8
 Answering system, 17
 announce only, 20
 delete messages, 22
 feature options, 21
 outgoing announcement, 19
 memos, 23
 play messages, 22, 25
 remote access, 25

C

Call logs, 14
 Caller ID, 14
 delete entries, 15
 dial entries, 16
 Call screening, 21
 Call waiting, 4, 9

D

Day/time, 18
 Delete Call Log entries, 15
 Dialing,
 manual dialing, 8
 memory dialing, 12

E

Ending calls, 8
 Error tones, 26

F

Flash (switchhook flash), 9

I

Incoming call log, 14
 Incoming calls, answering, 8
 Incoming messages, 17
 Indicator lights, 26

L

Last number redial, 8

M

Making calls, 8
 Memos, 23
 Menus, 2, 10-11, 21
 Message alert, 21
 Messages, 17-25
 Microphone, 19, 23
 Missed calls, 14
 Mute, 9

N

Number of rings before answer, 21

O

On/off button, 17
 Outgoing announcement, 19

P

Priority Call, 21
 Playback (messages), 22
 Problems, 27

Q

Quick reference guide, 2

R

Receiving calls, 8
 Redial, 8
 Repeat, 22
 Ring tone options, 21
 Ringer volume, 8

S

Skip, 22
 Sounds & alerts, 26
 Speakerphone, 8

T

Time, 14, 18
 Tones, 26
 Troubleshooting, 27

V

Volume controls, 8, 9



www.telephones.att.com

Copyright © 2005 Advanced American Telephones. All Rights Reserved.
AT&T and the Globe Design are trademarks of AT&T Corp.,
licensed to Advanced American Telephones. Printed in China. Issue 3 AT&T 07/23/05.