



Avid® ISIS® 2000 Setup Guide

Legal Notices

Product specifications are subject to change without notice and do not represent a commitment on the part of Avid Technology, Inc.

This product is subject to the terms and conditions of a software license agreement provided with the software. The product may only be used in accordance with the license agreement.

This product may be protected by one or more U.S. and non-U.S patents. Details are available at www.avid.com/patents.

Part of the software embedded in this product is gSOAP software.

Portions created by gSOAP are Copyright (C) 2001-2004 Robert A. van Engelen, Genivia inc. All Rights Reserved.

THE SOFTWARE IN THIS PRODUCT WAS IN PART PROVIDED BY GENIVIA INC AND ANY EXPRESS OR IMPLIED WARRANTIES, INCLUDING, BUT NOT LIMITED TO, THE IMPLIED WARRANTIES OF MERCHANTABILITY AND FITNESS FOR A PARTICULAR PURPOSE ARE DISCLAIMED. IN NO EVENT SHALL THE AUTHOR BE LIABLE FOR ANY DIRECT, INDIRECT, INCIDENTAL, SPECIAL, EXEMPLARY, OR CONSEQUENTIAL DAMAGES (INCLUDING, BUT NOT LIMITED TO, PROCUREMENT OF SUBSTITUTE GOODS OR SERVICES; LOSS OF USE, DATA, OR PROFITS; OR BUSINESS INTERRUPTION) HOWEVER CAUSED AND ON ANY THEORY OF LIABILITY, WHETHER IN CONTRACT, STRICT LIABILITY, OR TORT (INCLUDING NEGLIGENCE OR OTHERWISE) ARISING IN ANY WAY OUT OF THE USE OF THIS SOFTWARE, EVEN IF ADVISED OF THE POSSIBILITY OF SUCH DAMAGE.

This document is protected under copyright law. An authorized licensee of Avid ISIS 2000 may reproduce this publication for the licensee's own use in learning how to use the software. This document may not be reproduced or distributed, in whole or in part, for commercial purposes, such as selling copies of this document or providing support or educational services to others. This document is supplied as a guide for Avid ISIS 2000. Reasonable care has been taken in preparing the information it contains. However, this document may contain omissions, technical inaccuracies, or typographical errors. Avid Technology, Inc. does not accept responsibility of any kind for customers' losses due to the use of this document. Product specifications are subject to change without notice.

Copyright © 2012 Avid Technology, Inc. and its licensors. All rights reserved.

The following disclaimer is required by Sam Leffler and Silicon Graphics, Inc. for the use of their TIFF library:

Copyright © 1988–1997 Sam Leffler
Copyright © 1991–1997 Silicon Graphics, Inc.

Permission to use, copy, modify, distribute, and sell this software [i.e., the TIFF library] and its documentation for any purpose is hereby granted without fee, provided that (i) the above copyright notices and this permission notice appear in all copies of the software and related documentation, and (ii) the names of Sam Leffler and Silicon Graphics may not be used in any advertising or publicity relating to the software without the specific, prior written permission of Sam Leffler and Silicon Graphics.

THE SOFTWARE IS PROVIDED "AS-IS" AND WITHOUT WARRANTY OF ANY KIND, EXPRESS, IMPLIED OR OTHERWISE, INCLUDING WITHOUT LIMITATION, ANY WARRANTY OF MERCHANTABILITY OR FITNESS FOR A PARTICULAR PURPOSE.

IN NO EVENT SHALL SAM LEFFLER OR SILICON GRAPHICS BE LIABLE FOR ANY SPECIAL, INCIDENTAL, INDIRECT OR CONSEQUENTIAL DAMAGES OF ANY KIND, OR ANY DAMAGES WHATSOEVER RESULTING FROM LOSS OF USE, DATA OR PROFITS, WHETHER OR NOT ADVISED OF THE POSSIBILITY OF DAMAGE, AND ON ANY THEORY OF LIABILITY, ARISING OUT OF OR IN CONNECTION WITH THE USE OR PERFORMANCE OF THIS SOFTWARE.

The following disclaimer is required by the Independent JPEG Group:

This software is based in part on the work of the Independent JPEG Group.

This Software may contain components licensed under the following conditions:

Copyright (c) 1989 The Regents of the University of California. All rights reserved.

Redistribution and use in source and binary forms are permitted provided that the above copyright notice and this paragraph are duplicated in all such forms and that any documentation, advertising materials, and other materials related to such distribution and use acknowledge that the software was developed by the University of California, Berkeley. The name of the University may not be used to endorse or promote products derived from this software without specific prior written permission. THIS SOFTWARE IS PROVIDED "AS IS" AND WITHOUT ANY EXPRESS OR IMPLIED WARRANTIES, INCLUDING, WITHOUT LIMITATION, THE IMPLIED WARRANTIES OF MERCHANTABILITY AND FITNESS FOR A PARTICULAR PURPOSE.

Copyright (C) 1989, 1991 by Jef Poskanzer.

Permission to use, copy, modify, and distribute this software and its documentation for any purpose and without fee is hereby granted, provided that the above copyright notice appear in all copies and that both that copyright notice and this permission notice appear in supporting documentation. This software is provided "as is" without express or implied warranty.

Copyright 1995, Trinity College Computing Center. Written by David Chappell.

Permission to use, copy, modify, and distribute this software and its documentation for any purpose and without fee is hereby granted, provided that the above copyright notice appear in all copies and that both that copyright notice and this permission notice appear in supporting documentation. This software is provided "as is" without express or implied warranty.

Copyright 1996 Daniel Dardailler.

Permission to use, copy, modify, distribute, and sell this software for any purpose is hereby granted without fee, provided that the above copyright notice appear in all copies and that both that copyright notice and this permission notice appear in supporting documentation, and that the name of Daniel Dardailler not be used in advertising or publicity pertaining to distribution of the software without specific, written prior permission. Daniel Dardailler makes no representations about the suitability of this software for any purpose. It is provided "as is" without express or implied warranty.

Modifications Copyright 1999 Matt Koss, under the same license as above.

Copyright (c) 1991 by AT&T.

Permission to use, copy, modify, and distribute this software for any purpose without fee is hereby granted, provided that this entire notice is included in all copies of any software which is or includes a copy or modification of this software and in all copies of the supporting documentation for such software.

THIS SOFTWARE IS BEING PROVIDED "AS IS", WITHOUT ANY EXPRESS OR IMPLIED WARRANTY. IN PARTICULAR, NEITHER THE AUTHOR NOR AT&T MAKES ANY REPRESENTATION OR WARRANTY OF ANY KIND CONCERNING THE MERCHANTABILITY OF THIS SOFTWARE OR ITS FITNESS FOR ANY PARTICULAR PURPOSE.

This product includes software developed by the University of California, Berkeley and its contributors.

The following disclaimer is required by Paradigm Matrix:

Portions of this software licensed from Paradigm Matrix.

The following disclaimer is required by Ray Sauers Associates, Inc.:

"Install-It" is licensed from Ray Sauers Associates, Inc. End-User is prohibited from taking any action to derive a source code equivalent of "Install-It," including by reverse assembly or reverse compilation, Ray Sauers Associates, Inc. shall in no event be liable for any damages resulting from reseller's failure to perform reseller's obligation; or any damages arising from use or operation of reseller's products or the software; or any other damages, including but not limited to, incidental, direct, indirect, special or consequential Damages including lost profits, or damages resulting from loss of use or inability to use reseller's products or the software for any reason including copyright or patent infringement, or lost data, even if Ray Sauers Associates has been advised, knew or should have known of the possibility of such damages.

The following disclaimer is required by Videomedia, Inc.:

"Videomedia, Inc. makes no warranties whatsoever, either express or implied, regarding this product, including warranties with respect to its merchantability or its fitness for any particular purpose."

"This software contains V-LAN ver. 3.0 Command Protocols which communicate with V-LAN ver. 3.0 products developed by Videomedia, Inc. and V-LAN ver. 3.0 compatible products developed by third parties under license from Videomedia, Inc. Use of this software will allow "frame accurate" editing control of applicable videotape recorder decks, videodisc recorders/players and the like."

The following disclaimer is required by Altura Software, Inc. for the use of its Mac2Win software and Sample Source Code:

©1993–1998 Altura Software, Inc.

The following disclaimer is required by Interplay Entertainment Corp.:

The "Interplay" name is used with the permission of Interplay Entertainment Corp., which bears no responsibility for Avid products.

This product includes portions of the Alloy Look & Feel software from Incors GmbH.

This product includes software developed by the Apache Software Foundation (<http://www.apache.org/>).

© DevelopMentor

This product may include the JCifs library, for which the following notice applies:

JCifs © Copyright 2004, The JCIFS Project, is licensed under LGPL (<http://jcifs.samba.org/>). See the LGPL.txt file in the Third Party Software directory on the installation CD.

Avid Interplay contains components licensed from LavanTech. These components may only be used as part of and in connection with Avid Interplay.

Attn. Government User(s). Restricted Rights Legend

U.S. GOVERNMENT RESTRICTED RIGHTS. This Software and its documentation are "commercial computer software" or "commercial computer software documentation." In the event that such Software or documentation is acquired by or on behalf of a unit or agency of the U.S. Government, all rights with respect to this Software and documentation are subject to the terms of the License Agreement, pursuant to FAR §12.212(a) and/or DFARS §227.7202-1(a), as applicable.

Trademarks

003, 192 Digital I/O, 192 I/O, 96 I/O, 96i I/O, Adrenaline, AirSpeed, ALEX, Alienbrain, AME, AniMatte, Archive, Archive II, Assistant Station, AudioPages, AudioStation, AutoLoop, AutoSync, Avid, Avid Active, Avid Advanced Response, Avid DNA, Avid DNxcel, Avid DNxHD, Avid DS Assist Station, Avid Ignite, Avid Liquid, Avid Media Engine, Avid Media Processor, Avid MEDIArray, Avid Mojo, Avid Remote Response, Avid Unity, Avid Unity ISIS, Avid VideoRAID, AvidRAID, AvidShare, AVIDstripe, AVX, Beat Detective, Beauty Without The Bandwidth, Beyond Reality, BF Essentials, Bomb Factory, Bruno, C|24, CaptureManager, ChromaCurve, ChromaWheel, Cineractive Engine, Cineractive Player, Cineractive Viewer, Color Conductor, Command|24, Command|8, Control|24, Cosmonaut Voice, Countdown, d2, d3, DAE, D-Command, D-Control, Deko, DekoCast, D-Fi, D-fx, Digi 002, Digi 003, DigiBase, Digidesign, Digidesign Audio Engine, Digidesign Development Partners, Digidesign Intelligent Noise Reduction, Digidesign TDM Bus, DigiLink, DigiMeter, DigiPanner, DigiProNet, DigiRack, DigiSerial, DigiSnake, DigiSystem, Digital Choreography, Digital Nonlinear Accelerator, DigiTest, DigiTranslator, DigiWear, DINR, DNxchange, Do More, DPP-1, D-Show, DSP Manager, DS-StorageCalc, DV Toolkit, DVD Complete, D-Verb, Eleven, EM, Euphonix, EUCON, EveryPhase, Expander, ExpertRender, Fader Pack, Fairchild, FastBreak, Fast Track, Film Cutter, FilmScribe, Flexevent, FluidMotion, Frame Chase, FXDeko, HD Core, HD Process, HDpack, Home-to-Hollywood, HYBRID, HyperSPACE, HyperSPACE HDCAM, iKnowledge, Image Independence, Impact, Improv, iNEWS, iNEWS Assign, iNEWS ControlAir, InGame, Instantwrite, Instinct, Intelligent Content Management, Intelligent Digital Actor Technology, IntelliRender, Intelli-Sat, Intelli-sat Broadcasting Recording Manager, InterFX, Interplay, inTONE, Intraframe, iS Expander, iS9, iS18, iS23, iS36, ISIS, IsoSync, LaunchPad, LeaderPlus, LFX, Lightning, Link & Sync, ListSync, LKT-200, Lo-Fi, MachineControl, Magic Mask, Make Anything Hollywood, make manage move | media, Marquee, MassivePack, Massive Pack Pro, Maxim, Mbox, Media Composer, MediaFlow, MediaLog, MediaMix, Media Reader, Media Recorder, MEDIArray, MediaServer, MediaShare, MetaFuze, MetaSync, MIDI I/O, Mix Rack, Moviestar, MultiShell, NaturalMatch, NewsCutter, NewsView, NewsVision, Nitris, NL3D, NLP, NSDOS, NSWIN, OMF, OMF Interchange, OMM, OnDVD, Open Media Framework, Open Media Management, Painterly Effects, Palladium, Personal Q, PET, Podcast Factory, PowerSwap, PRE, ProControl, ProEncode, Profiler, Pro Tools, Pro Tools|HD, Pro Tools LE, Pro Tools M-Powered, Pro Transfer, QuickPunch, QuietDrive, Realtime Motion Synthesis, Recti-Fi, Reel Tape Delay, Reel Tape Flanger, Reel Tape Saturation, Reprise, Res Rocket Surfer, Reso, RetroLoop, Reverb One, ReVibe, Revolution, rS9, rS18, RTAS, Salesview, Sci-Fi, Scorch, ScriptSync, SecureProductionEnvironment, Serv|GT, Serv|LT, Shape-to-Shape, ShuttleCase, Sibelius, SimulPlay, SimulRecord, Slightly Rude Compressor, Smack!, Soft SampleCell, Soft-Clip Limiter, SoundReplacer, SPACE, SPACESHift, SpectraGraph, SpectraMatte, SteadyGlide, Streamfactory, Streamgenie, StreamRAID, SubCap, Sundance, Sundance Digital, SurroundScope, Symphony, SYNC HD, SYNC I/O, Synchronic, SynchroScope, Syntax, TDM FlexCable, TechFlix, Tel-Ray, Thunder, TimeLiner, Titansync, Titan, TL Aggro, TL AutoPan, TL Drum Rehab, TL Everyphase, TL Fauxlder, TL In Tune, TL MasterMeter, TL Metro, TL Space, TL Utilities, tools for storytellers, Transit, TransJammer, Trillium Lane Labs, TruTouch, UnityRAID, Vari-Fi, Video the Web Way, VideoRAID, VideoSPACE, VTEM, Work-N-Play, Xdeck, X-Form, Xmon and XPAND! are either registered trademarks or trademarks of Avid Technology, Inc. in the United States and/or other countries.

Apple, Macintosh, and Safari are either registered trademarks or trademarks of Apple Computer, Inc., registered in the U.S. and other countries. HP is a registered trademark of Hewlett-Packard Company. Intel is a registered trademark of Intel Corporation. Java is a trademark of Sun Microsystems in the United States and/or other countries. Kingston is a registered trademarks of Kingston Technology Corporation. All other marks may be the property of their respective titleholders. Windows is either a registered trademark or trademark of Microsoft Corporation in the United States and/or other countries. All other trademarks contained herein are the property of their respective owners.

Avid ISIS 2000 Setup Guide • 0175-31140-00 Rev. B • November 2013 • Created 11/8/13

Contents

	Using This Guide	11
	Symbols and Conventions	11
	If You Need Help	12
	Accessing the Online Documentation	12
	Avid Training Services	13
Chapter 1	Avid ISIS 2000 System Overview	14
	System Director	15
	System Director Front Panel	16
	System Director Rear Panel	17
	Second System Director	18
	Engine	18
	Engine Front View	19
	Engine Control Panel	19
	Engine Rear View	21
	Cooling Modules	21
	Power Supplies	22
	Storage Configurations	24
	Storage Group Size	24
	RAID-6 Storage Groups, Single Drive	24
	RAID-6 Storage Groups, Dual Drive Failure	24
	Drive Array and Slot Locations	25
	ISIS 2000-240 Media Drive Configuration	25
	ISIS 2000-120 Media Drive Configuration	26
	Client	27
	CIFS and FTP Clients	28
	Network Zone Configurations	28
	Zone 1 Clients (Direct Connected)	29
	Zone 2 Clients (Indirect Connect) Configuration	29
	Zone 3 and Zone 4 Client Configuration	30

	Cabling	31
Chapter 2	Connecting the ISIS Equipment	32
	Rack-Mounting the Equipment	32
	Rack-Mounting Example	33
	Installing Rack-Mount Rails and Brackets	33
	Rack-mount Requirements	34
	Positioning the server in the Rack	35
	Separating the Slide Rails	35
	Attaching Inner Slide Rails to the System Director	36
	Attaching the Outer Rails to a Square-Hole Rack	37
	Attaching the Outer Rails to a Threaded-Hole Rack	39
	Securing the System Director in a Rack	41
	Mounting the Engine	42
	Opening and Closing the Media Drive Drawers	46
	Installing the Media Drives	48
	Installing the Cooling Modules	50
	Installing the Power Supplies	50
	Installing the Engine Controller	51
	Connecting Power to Equipment	52
	Connecting Power Cords	53
	Turning System On and Off	53
	Connecting a Keyboard, Monitor, and Mouse	54
	Setting-Up the Network Address On the Engine	55
	Connecting Network Cables with a 1 Gb System Director Connection	58
	Connecting Network Cables with a 10 Gb System Director Connection	60
Chapter 3	Installing Software and Configuring	64
	Software Installation	64
	Configuration Overview	64
	Loading the Software	65
	Separate VLAN on Switch for ISIS 2000	71
	Activating the License Key	71
	Creating an Active File System on the System Director	71
	Installing Software on the Engine	73

	Binding the Storage Managers	78
	Creating a Storage Group	79
	Creating Workspaces	79
	Creating User Accounts	79
	Turning Off the CIFS Service With a 1 Gb Connected System Director	79
	Checking the Status of the System Director.	81
	Loading Client Software	82
	Configuring Client Software	86
	Adding a Remote Host for Zone 3 and 4 Clients.	88
	Avid Interplay Authentication.	90
Chapter 4	Configuring System Director Resiliency.	91
	System Director Failover.	91
	Cabling Dual System Directors	92
	Setting IP Addresses for Crossover Link	93
	Configure a Failover Connection.	93
	Binding Order for Health Monitoring	101
	Stopping and Restarting the System Directors	101
Chapter 5	Avid ISIS Software Licensing	104
	What You Need to Activate the ISIS Software License.	104
	License Activation Using an Internet Connection	105
	License Activation Without an Internet Connection.	107
	Deactivating the License.	109
	License Requirement with Host Name Change	110
Chapter 6	Configuring the Server for CIFS Access.	111
	Creating Windows Users and User Groups on the System Director.	111
	Adding Users and Setting Permissions.	112
	Setting the CIFS Bandwidth	115
	Mapping Network Workspaces on CIFS Clients	115
Chapter 7	Configuring the Server for FTP Access	116
	Setup the System Director for FTP	117
	Creating Windows Users and User Groups on the Operating System.	117
	Creating ISIS Users on the System Director	118
	Creating a Virtual Host Name.	118

	Creating Virtual Workspaces	120
	Log In Using the Command Prompt	121
Chapter 8	Avid ISIS 2000 Upgrade Guidelines	123
	Health Check.	123
	Software Upgrade Process	124
	ISIS 2000-120 to ISIS 2000-240 Engine Upgrade	127
	Clearing Foreign Configurations on Used Drives	131
	Post Upgrade System Verification	132
	Preupgrade Information	134
	Zone 2 Switch Information	134
	System Director Information	135
	ISIS Engine Information	136
	On Site Spares	136
	Spares Checklist	137
	Additional spares for a comprehensive spares parts list:	137
Chapter 9	Avid ISIS Recommended Maintenance	138
	Minimum Storage Space Requirement	138
	Daily Maintenance	138
	Weekly Maintenance	140
	Saving ISIS Metadata	140
	Available Utilities	141
	Client Manager Maintenance	142
	Status Indicators and Troubleshooting	142
	Complete Server Room Shutdown	142
Chapter 10	Status LEDs	144
	Hardware Faults	144
	Front Panel LEDs	145
	Drawer LEDs	146
	Power Supply LEDs	148
	Cooling Module LEDs	149
	Media Drive LED	150
	Engine Controller LEDs	151
	Management Console Error Messages	152

	Missing Spare Drive Message	152
	Invalid Drive — Foreign Disk Message	153
	Disk Performance Degraded Message	153
	Invalid Number of Disks Message	154
	No RAID Arrays Exist	154
	Not All RAID Arrays Are Active	154
	Thermal Sensors	155
	Thermal Monitoring and Control	155
	Thermal Alarm	156
Chapter 11	Adding and Replacing Hardware	157
	Continuous Operation During Replacement	157
	Media Drive Drawer	158
	Media Drive Replacement	159
	Removing a Media Drive	160
	Replacing a Media Drive	162
	Forcing a Foreign Drive to Become a Spare	163
	Cooling Module Replacement	164
	Power Supply Replacement	165
	Engine Controller Replacement	166
	Engine Replacement	170
	Replacing an Internal System Director Drive	172
	Saving ISIS Metadata	173
	Replacing System Drives in the System Director	174
	Moving the Metadata to a New System Director	176
	Network Switch Replacement	177
	Adding an ISIS 2000 Engine to Your Infrastructure	179
Chapter 12	Using the Product Recovery USB for 64-bit System Directors	184
	Creating a Product Recovery USB Flash Drive	184
	Reinstalling the Windows Storage Server 2008 R2 Operating System	186
	Configuring the System Drive Using Windows 2008 Storage Server Setup	188
Chapter 13	Specifications and Notices	190
	Dimensions and Weight	190
	Environment	190

	Electrical	191
	Uninterruptible Power Supply (UPS)	191
	Supported Cabling	192
Appendix A	Safety and Regulatory Information	196
	Warnings and Cautions	196
	FCC Notice	197
	Class A Equipment	197
	Modifications	198
	Cables	198
	Canadian Notice (Avis Canadien)	198
	Class A Equipment	198
	LED Safety Notices	198
	European Union Declaration of Conformity	199
	Disposal of Waste Equipment by Users in the European Union	201
	Argentina Conformity	201
	Australia and New Zealand EMC Regulations	201
	Japan EMC Regulations	202
	Class A Equipment	202
	Korean EMC Regulations	202
	Class A Equipment	202
	Taiwan EMC Regulations	202
	Index	208

Using This Guide

The Avid ISIS® media network provides a high-performance distributed file system that contains high-capacity shared media storage for workgroups of connected Avid® editing workstations.



This document describes features and setup information for the Avid ISIS 2000 shared storage network. Your system might not contain certain features that are covered in the documentation.

Symbols and Conventions

Avid documentation uses the following symbols and conventions:

Symbol or Convention	Meaning or Action
	A note provides important related information, reminders, recommendations, and strong suggestions.
	A caution means that a specific action you take could cause harm to your computer or cause you to lose data.
	A warning describes an action that could cause you physical harm. Follow the guidelines in this document or on the unit itself when handling electrical equipment.
>	This symbol indicates menu commands (and subcommands) in the order you select them. For example, File > Import means to open the File menu and then select the Import command.
▶	This symbol indicates a single-step procedure. Multiple arrows in a list indicate that you perform one of the actions listed.
(Windows), (Macintosh), or (Linux)	This text indicates that the information applies only to the specified operating system, either Windows Macintosh OS X or Linux.
Bold font	Bold font is primarily used in task instructions to identify user interface items and keyboard sequences.
<i>Italic font</i>	Italic font is used to emphasize certain words and to indicate variables.
Courier Bold font	Courier Bold font identifies text that you type.

Symbol or Convention Meaning or Action

Ctrl+key or mouse action Press and hold the first key while you press the last key or perform the mouse action. For example, Command+Option+C or Ctrl+drag.

If You Need Help

If you are having trouble using your Avid product:

1. Retry the action, carefully following the instructions given for that task in this guide. It is especially important to check each step of your workflow.
2. Check the latest information that might have become available after the documentation was published.

New information would be found in the ReadMe file supplied on your Avid software installation kit as a PDF document and is also available online.

You should always check online for the most up-to-date release notes or ReadMe because the online version is updated whenever new information becomes available. To view the online versions, visit the Knowledge Base at www.avid.com/US/support.

3. Check the documentation that came with your Avid application or your hardware for maintenance or hardware-related issues.
4. Visit the online Knowledge Base at www.avid.com/US/support. Online services are available 24 hours per day, 7 days per week. Search this online Knowledge Base to find answers, to view error messages, to access troubleshooting tips, to download updates, and to read or join online message-board discussions.

Accessing the Online Documentation

The Avid ISIS online documentation contains all the product documentation in PDF format. You can access the documentation in the AvidISISDocumentation folder on the Avid ISIS installer kit. You need to download and install Acrobat Reader on your Avid ISIS before you can access the PDF documentation.



You need to download and install Acrobat Reader on your Avid ISIS before you can access the PDF documentation.

To access the online documentation from the installer kit:

1. Insert your Avid ISIS USB flash drive with the Avid ISIS software kit into the USB port.
2. Navigate to the `[USB flash drive]:\AvidISISDocumentation` folder, and double-click the PDF file for the document you want to view.

Avid Training Services

Avid makes lifelong learning, career advancement, and personal development easy and convenient. Avid understands that the knowledge you need to differentiate yourself is always changing, and Avid continually updates course content and offers new training delivery methods that accommodate your pressured and competitive work environment.

For information on courses/schedules, training centers, certifications, courseware, and books, please visit www.avid.com/support and follow the Training links, or call Avid Sales at 800-949-AVID (800-949-2843).

1

Avid ISIS 2000 System Overview

The Avid ISIS® 2000 system is a nearline product that provides lower cost per gigabit (GB) disk-based storage than the ISIS 7500 | 7000 and ISIS 5500 | 5000 real-time storage systems (online). This nearline system provides rapid access to material for which real-time output is not required, but the performance and accessibility of tape archival storage is not suitable. Avid ISIS network storage systems are built for media and entertainment. They enable multiple clients to share, capture, play, and edit video and audio media.

Clients access any combination of ISIS online systems (ISIS 5500 | 5000 and ISIS 7500 | 7000) and ISIS nearline systems (ISIS 2000) system through external switch connections. The ISIS 2000 Management Console provides the same workspace and user functionality offered in all ISIS environments. The ISIS 2000 nearline system workflows provides basic video playback of low bit rate media and high-speed file transfers to online ISIS systems.

Avid ISIS 2000 Engines are available in two configurations:

- ISIS 2000-240 — 82, 3 TB drives, providing 240 TB of raw storage which equates to 192 TB of usable storage
- ISIS 2000-120 — 42, 3 TB drives, providing 120 TB of raw storage which equates to 96 TB of usable storage

A typical ISIS 2000 workflow is to move media that is no longer being used in the ISIS 7500 | 7000 and ISIS 5500 | 5000 online systems to ISIS 2000 Workspaces for longer term storage. This frees up faster storage elements for higher performance work.

The ISIS 2000 is not intended to be used for real time editing of high resolution material, although real time playback of resolutions of up to 3 Mb/s or less is supported.

Information that applies to specific models is specified in that section. This chapter provides an overview of the Avid ISIS 2000 system and the basic function of each ISIS component. Other chapters in this guide describe the cable connections between the ISIS 2000 System Director, the ISIS 2000 Engines, and configuring the system.

The following sections explain these components and some basic client configurations:

- System Director
- Engine
- Storage Configurations

- Client
- Client
- Network Zone Configurations
- Cabling

System Director

The Avid ISIS 2000 System Director uses the Windows® Storage Server 2008 R2 operating system with Service Pack 1. The Avid ISIS client operating systems that are supported in your ISIS software release is listed in the *Avid ISIS ReadMe*.



The Windows Product Key Certificate of Authenticity is attached to the top cover of the Avid ISIS System Director.

The System Director is 1U (rack unit) in size (see [“System Director Front Panel” on page 16](#)) and manages the metadata by storing directory information and file attributes. The System Director does not store the data used by share clients (for example media files), these data files are stored on the drives within the Engine.



The System Director password is preset to is-admin. Not to be confused with the System Director Web Page Administrator user whose default password is blank.

System Directors, workgroup servers, and clients must all be synchronized with a common time-of-day. For information on setting the Network Time Protocol (NTP), see [“Setting-Up the Network Address On the Engine” on page 55](#).

The System Director connects to the ISIS switch through either a 1 Gb or 10 Gb connection. This depends mostly on the availability of 10 Gb ports on the ISIS switch. You must use a 10 Gb connection to the switch if you plan on using the built-in File Gateway capabilities. The File Gateway feature allows you to connect CIFS and FTP clients. When setting up CIFS clients, see [“Configuring the Server for CIFS Access” on page 111](#). When setting up FTP clients, see [“Configuring the Server for FTP Access” on page 116](#).

The System Director provides a location to coordinate file access modes (read/write), file locking, range locking, performance data collection, logging, file lookup, and directory change tracking for client systems. Examples of what the System Director is able to provide to a client or storage element are:

- Identity of all storage elements connected to the system
- Information about the drives, power, cooling and Engine Controllers in the configuration.
- List of workspaces to include name and their unique ID number

- List of users and groups within the system
- Identity of all System Directors in the system (if you have more than one System Director)

Avid ISIS assures media protection and availability using the following techniques:

- Mirrored system drives are used for system operation and System Director metadata storage.
- A failed system drive can be replaced without interrupting the operation of the Avid ISIS.
- The 82 media drives are configured into eight RAID 6 groups with two drives reserved as hot spares. If any of the RAID drives fail, the Avid ISIS automatically uses the spare drive to rebuild the RAID group. The failed drive can be removed and replaced with a new drive without interrupting the operation of the Avid ISIS.

System Director Front Panel

The following figure shows the front view and control panel of the System Director.

System Director Front View

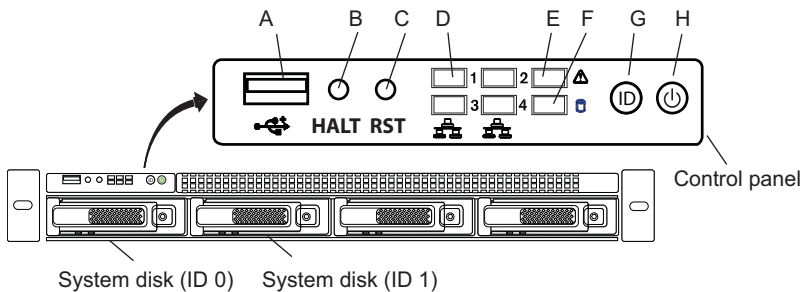

The following table describes the control panel shown in the previous figure.

System Control Panel

Letter	Component	Description
A	Universal Serial Bus (USB) port	USB 2.0 device port on the front of the system supports one USB device. Recommended for use when re-imaging the system drives or loading software. Two more USB ports are located on the back of the system.

System Control Panel (Continued)

Letter	Component	Description
B	Halt or Non-maskable interrupt (NMI) button	<p>The halt or NMI signal halts the processor, which effectively halts the server. A NMI is the highest priority interrupt and cannot be masked by software.</p> <p> If the Halt/NMI button is pressed, the NMI signal locks the system and the system must be restarted to clear the interrupt.</p>
C	System reset button	Performs a soft reset when pressed. Do not use this button unless the system has had a fatal error and you need to restart. A soft reset restarts the system; it clears all active program memory (you lose unsaved work) and shuts down all active programs.
D	Four green network activity LEDs	<p>Illuminates green when a good network connection is established and blinks when there is network activity on the four built-in 1-GB network ports.</p> <p>The number beside the LED corresponds with the number beside the network port on the rear of the enclosure. For example, Connector 1 is LED 1 on the front, see “System Director Rear Panel” on page 17.</p>
E	Red System error LED	Illuminates red when an error is detected with the system (fan, power supply, temperature, voltage).
F	System Drive activity LED	Indicates drive activity from the onboard SATA controller and blinks when either of the system drives is being accessed.
G	System ID button	When pressed it illuminates (blinks) blue and also illuminates an LED on the rear of the enclosure. The rear LED is also blue and is visible on the lower left-hand side of the Ethernet ports inside of the enclosure. It is used to identify a system for servicing when it is installed in a high-density rack/cabinet populated with several other similar systems.
H	Power button	Press to power on the enclosure. Power button illuminates green when the power is on.

System Director Rear Panel

The following figure shows the rear panel of the System Director and the function of each connection. The System Director comes with a Myricom dual-port 10 Gb network board installed in the System Director. Also include is an SFP+ optical transceiver for the port.

System Director Rear View

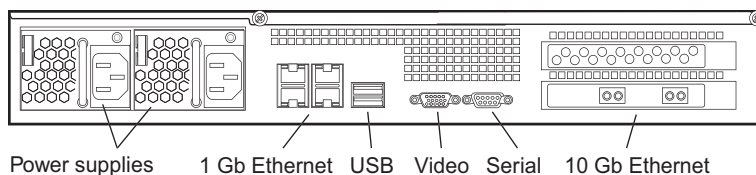

Second System Director

You can purchase a second System Director and configure it on the same subnets as the original System Director. This provides a redundant System Director that is in constant contact with the original System Director. The second System Director automatically takes over if the original System Director fails (For more information see [“Configuring System Director Resiliency” on page 91](#)).

Engine

The Engine is 5U (rack unit) in size and stores the data shared by the ISIS clients. Up to five Engines are supported in the ISIS 2000 environment providing 1.2 petabyte (PB) of raw storage (960 TB usable storage). Avid ISIS 2000 Engines are available in two configurations, see [“ISIS 2000-240 Media Drive Configuration” on page 25](#) and [“ISIS 2000-120 Media Drive Configuration” on page 26](#). Both models of Avid ISIS 2000 Engines are populated with 3 terabytes (TB) SAS drives. These media drives are configured for redundant array of independent disks (RAID) 6 storage protection.

Engines can be configured as separate Storage Groups or be added to existing Storage Groups. If you choose to add the new Engines to an existing Storage Group, a redistribution of the existing data is initiated to spread the data evenly across all drives in the Storage Group.

The data flows to and from the Engine through the Engine Controller using a 10-Gb Ethernet connection. Only the left connector (as seen from the rear of the Engine Engine Rear View) is used to connect the Engine to the ISIS switch. This connection provides access to the data on media drives to the System Director and clients. The 10-Gb Ethernet ports on both the switch and Engine Control require SFP+ transceivers. For instructions on see [“Connecting Network Cables with a 10 Gb System Director Connection” on page 60](#).

The Engine contains the following components:

- Engine Front View
- Engine Control Panel
- Engine Rear View

- Cooling Modules
- Power Supplies

Engine Front View

Each drawer in the Engine allows access to 42 drive slots. The number of media drives populated in each drawer varies depending on your ISIS 2000 Engine configuration (ISIS 2000-240 or ISIS 2000-120). The first drive slot is located in the front-row, left-side of the top drawer and the last drive is in the last row on the far-right portion of the drawer. The second drawer is ordered in the same way; left-to-right in each of the three rows starting in the front and ending in the back right corner. For more information on the drive slot configuration, see “[ISIS 2000-240 Media Drive Configuration](#)” on page 25 and “[ISIS 2000-120 Media Drive Configuration](#)” on page 26.

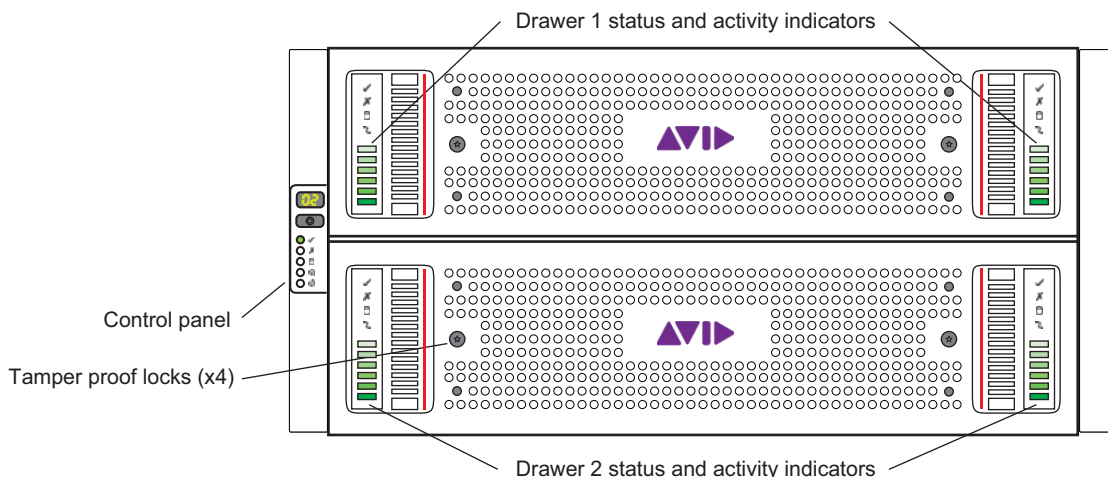

Each drive can be removed and replaced separately with the power on.



If you replace a drive with power on, the LEDs in all of the drives go off momentarily. This does not represent a problem. All functions are still active and working properly.

Engine Control Panel

The following figure shows the ISIS 2000 Engine control panel.

ISIS 2000 Engine Front Panel

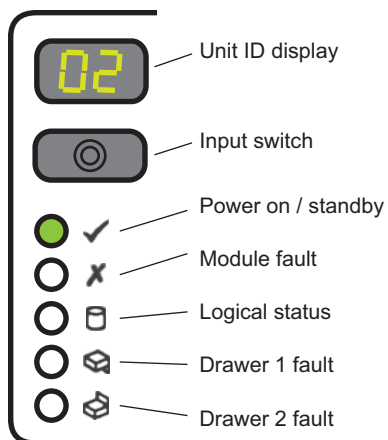

The following table describes the control panel shown in the previous figure.

Engine Control Panel

Component	Description
Unit ID Display	Displays the unit number assigned to the Engine. When a signal is sent from the software, the ID number blinks to identify the Engine. This helps locate the Engine when it is installed in a high-density rack/cabinet populated with several other similar systems.
Input Switch	Press to power on the enclosure.
Power on / Standby Indicator	Illuminates green when the power is on. A power switch is located on each of the two power supplies on the back of the Engine.
Module Fault Indicator	Illuminates amber when an error is detected with the system. The following are possible faults. <ul style="list-style-type: none"> On: with single beep, then double beep — power on test state. On: any power supply, voltage, fan, module, or temperature (over or under) fault Flashing: logical fault — unknown, invalid, or mixed module type installed, bus failure (inter communication failure), or EBOD VPD configuration error. On: Drive failure causing loss of availability or redundancy Flashing: when both the Module Fault and Logical Status LEDs are flashing, the unit ID number is different from “Start of Day.”

Engine Control Panel (Continued)

Component	Description
Logical Status Indicator	Flashes amber when arrays are performing a background function. When both the Module Fault and Logical Status LEDs are flashing, the unit ID number is different from “Start of Day.”
Drawer 1 Fault Indicator	Illuminates amber when an fault is detected with a drive, cable, or fan in the top drawer.
Drawer 2 Fault Indicator	Illuminates amber when an fault is detected with a drive, cable, or fan in the bottom drawer.

Engine Rear View

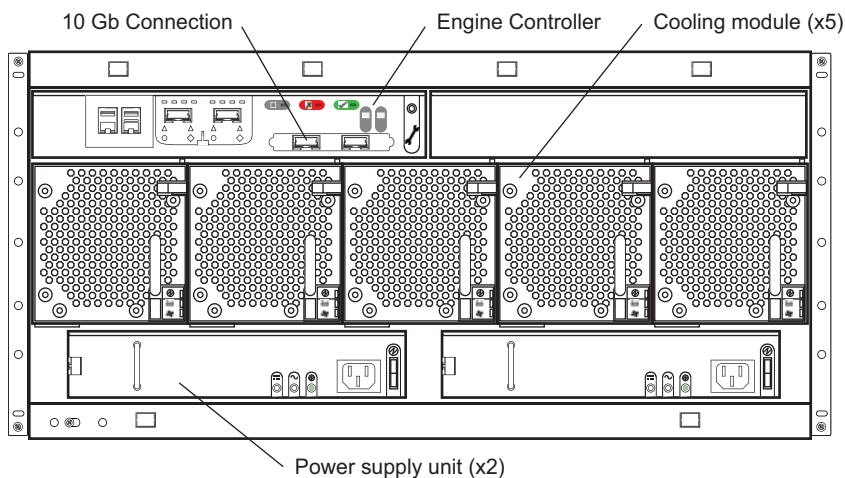

The following figure shows the rear of the Engine in a configuration that contains the following:

- One Engine Controller (only supported in the left slot as seen from the rear of the Engine)
- Five cooling Modules
- Two power supplies



Cooling Modules

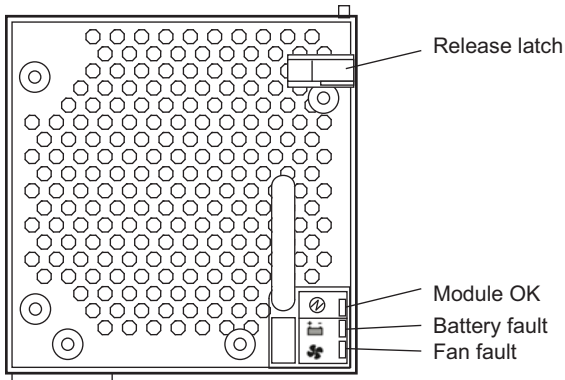

Five cooling modules are powered on when the power supplies are on. They contain fans that cool the system. The system only needs three of the five cooling modules to supply the needed cooling for the Engine to function properly. You can remove and replace a cooling modules while the system is running if one fails.

-  **Leave failed modules in place until you have a replacement so you maintain the proper airflow. You need to obtain a replacement as soon as possible.**
-  **Only trained Avid qualified service personnel should remove and replace modules while the Engine is running. Since power to the Engine is still applied internally to the midplane, you must always keep your hands external to the Engine when a module is removed from the Engine.**



Power Supplies

The power supplies are powered on when the power cord is plugged in and the power switch is on. The power supplies not only provide power, but they also contain fans that cool the system. The system only needs one of the two power supplies to supply the needed power to function properly. You can remove and replace a power supply temporarily while the system is running if one fails.

-  **Leave failed modules in place until you have a replacement so you maintain the proper airflow. You need to obtain a replacement as soon as possible.**
-  **Only trained Avid qualified service personnel should remove and replace modules while the Engine is running. Since power to the Engine is still applied internally to the midplane, you must always keep your hands external to the Engine when a module is removed from the Engine.**

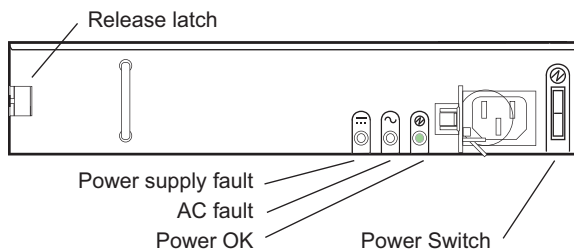

Engine Power Supply Panel

Component	Description
Release Latch	Displays the unit number assigned to the Engine. When a signal is sent from the software, the ID number blinks to identify the Engine. This helps locate the Engine when it is installed in a high-density rack/cabinet populated with several other similar systems.
Power Supply Fault Indicator	<p>Illuminates amber when an error is detected with the system. The following are possible faults.</p> <ul style="list-style-type: none"> • On: with single beep, then double beep — power on test state. • On: any power supply, voltage, fan, module, or temperature (over or under) fault • Flashing: logical fault — unknown, invalid, or mixed module type installed, bus failure (inter communication failure), or EBOD VPD configuration error. • On: Drive failure causing loss of availability or redundancy • Flashing: when both the Module Fault and Logical Status LEDs are flashing, the unit ID number is different from “Start of Day.”
AC Input Fault Indicator	Flashes amber when arrays are performing a background function. When both the Module Fault and Logical Status LEDs are flashing, the unit ID number is different from “Start of Day.”
Power on / Standby Indicator	Illuminates green when the power is on. A power switch is located on each of the two power supplies on the back of the Engine.
Power Switch	Press to power on the enclosure.

Storage Configurations

Avid ISIS 2000 Engines are populated with 3 terabyte (TB) SAS drives using parity protected disk storage utilizing a RAID 6 (redundant array of independent disks, level 6) algorithm. The ISIS 2000-240 is a fully populated configuration with 82 media drives providing up to 192 TB. These 82 media drives add up to 240 TB of raw storage which equates to 192 TB of usable storage (80%) after configuring the RAID set.

The ISIS 2000-120 is populated with 42 drive between the two drawers. These 42 media drives add up to 120 TB of raw storage which equates to 96 TB of usable storage (80%) after configuring the RAID set.

Storage Group Size

An ISIS 2000-120 Engine provides one Storage Element. If you have an ISIS 2000-240 then you have two Storage Elements. The Storage Element is used to create a Storage Group in the ISIS file system (one Storage Group per Engine). The media drives in each Engine are bound into Storage Groups. A fully populated ISIS 2000-240 Engine can be bound into one or two Storage Groups or you can combine multiple Engines to be a single Storage Group.

If you have Engines configured as in a single Storage Group and want to make two Storage Groups, you must delete the Storage Group and create two new Storage Groups. Data is stored in the Storage Group in 4 MB chunk sizes. You cannot change the chunk size of a Storage Group.



When you delete the Storage Group all data on the Storage Group is lost.

RAID-6 Storage Groups, Single Drive

When there is a single drive failure in an ISIS Storage Group configured with RAID protection, the Storage Group continues to function normally at a lower bandwidth.

- Upon the initiation of the single drive removal, all new writes to the Storage Group have the full benefit of RAID-6 protection (dual-parity protection).
- Upon completion of the drive remove process and the RAID set is repaired, existing data in the Storage Group is once again fully protected. Prior to completion, if another drive were to fail, the Storage Group would be in an unprotected state (though no data would be lost).

RAID-6 Storage Groups, Dual Drive Failure

It is considered an “unprotected state” if you have two failed drives in a RAID-6 Storage Group. In an unprotected state with no additional failures, read operations continue to function normally at a lower bandwidth.

It is highly recommended that you replace any failed drives immediately, to create new hot spares for possible future drive failures. This ensures full protection of all stored data at the earliest possible time.

Drive Array and Slot Locations

Avid ISIS 2000 Engines are available in two configurations; both configurations are populated with 3 TB SAS drives. These media drives are configured for redundant array of independent disks (RAID) 6 storage protection.

New installations are created using a common slot configuration. However, once a disk has failed, the initial layout changes and the default configuration no longer applies. The numbers assigned to the slots and the group numbers are *not* displayed in the ISIS software.

- ISIS 2000-240 Media Drive Configuration — 82 media drives providing 240 TB of raw storage which equates to 192 TB of usable storage with two spares.
- ISIS 2000-120 Media Drive Configuration — 42 media drives providing 120 TB of raw storage which equates to 96 TB of usable storage with two spares.

ISIS 2000-240 Media Drive Configuration

The ISIS 2000-240 has 82 media drives with two drives reserved as hot spares. The drives are configured into eight RAID 6 groups (10 drives in each group) in each Avid ISIS-240 Engine. The hot spares are automatically used whenever a RAID set detects a degraded drive. This results in continued access to your workspace data with no data loss during the failure and repair.



The spare drives are created at the end of the last RAID group in bottom drawer when the RAID groups are initially configured. Once a drive group has used a spare drive and a new spare is established, the original configuration no longer applies.

240 TB, Drawer 1 (Top) — Initial Media Drive Slot Locations and RAID Groups

Drive Slot 28	Drive Slot 29	Drive Slot 30	Drive Slot 31	Drive Slot 32	Drive Slot 33	Drive Slot 34	Drive Slot 35	Drive Slot 36	Drive Slot 37	Drive Slot 38	Drive Slot 39	Drive Slot 40	Drive Slot 41
Drive Slot 14	Drive Slot 15	Drive Slot 16	Drive Slot 17	Drive Slot 18	Drive Slot 19	Drive Slot 20	Drive Slot 21	Drive Slot 22	Drive Slot 23	Drive Slot 24	Drive Slot 25	Drive Slot 26	Drive Slot 27

Drive Slot 0 Empty	Drive Slot 1	Drive Slot 2	Drive Slot 3	Drive Slot 4	Drive Slot 5	Drive Slot 6	Drive Slot 7	Drive Slot 8	Drive Slot 9	Drive Slot 10	Drive Slot 11	Drive Slot 12	Drive Slot 13
Top Drawer — Front													

240 TB, Drawer 2 (Bottom) — Initial Media Drive Slot Locations and RAID Groups

Drive Slot 70	Drive Slot 71	Drive Slot 72	Drive Slot 73	Drive Slot 74	Drive Slot 75	Drive Slot 76	Drive Slot 77	Drive Slot 78	Drive Slot 79	Drive Slot 80	Drive Slot 81	Drive Slot 82	Drive Slot 83
Drive Slot 56	Drive Slot 57	Drive Slot 58	Drive Slot 59	Drive Slot 60	Drive Slot 61	Drive Slot 62	Drive Slot 63	Drive Slot 64	Drive Slot 65	Drive Slot 66	Drive Slot 67	Drive Slot 68	Drive Slot 69
Drive Slot 42 Empty	Drive Slot 43	Drive Slot 44	Drive Slot 45	Drive Slot 46	Drive Slot 47	Drive Slot 48	Drive Slot 49	Drive Slot 50	Drive Slot 51	Drive Slot 52	Drive Slot 53	Drive Slot 54	Drive Slot 55
Bottom Drawer — Front													

ISIS 2000-120 Media Drive Configuration

The ISIS 2000-120 has 42 media drives with two drives reserved as hot spares. The drives are configured in the Avid ISIS-120 Engine as four RAID 6 groups (10 drives in each group). The hot spares are initially created in the bottom drawer and are automatically used whenever a RAID set detects a degraded drive. This allows for continued access to your workspace data with no data loss during the failure and repair.



The spare drives are created in the bottom drawer when the RAID groups are initially configured. Once a drive group has used a spare drive and a new spare is established, the original configuration no longer applies.



When replacing a failed media drive, you must install the replacement drive in the slot where you removed the failed drive. Do not install replacement drives in the slots identified as “Not Used” in the following illustrations.

120 TB, Drawer 1 (Top) — Initial Media Drive Slot Locations and RAID Groups

Drive Slot 0	Drive Slot 1	Drive Slot 2	Drive Slot 3	Drive Slot 4	Drive Slot 5	Drive Slot 6	Drive Slot 7	Drive Slot 8	Drive Slot 9	Drive Slot 10	Drive Slot 11	Drive Slot 12	Drive Slot 13
Not Used	Not Used	Not Used	Not Used	Not Used	Not Used	Not Used	Not Used	Not Used	Not Used	Not Used	Not Used	Not Used	Not Used
Drive Slot 14	Drive Slot 15	Drive Slot 16	Drive Slot 17	Drive Slot 18	Drive Slot 19	Drive Slot 20	Drive Slot 21	Drive Slot 22	Drive Slot 23	Drive Slot 24	Drive Slot 25	Drive Slot 26	Drive Slot 27
Not Used	Not Used	Not Used	Not Used	Not Used	Not Used	Not Used	Not Used	Not Used	Not Used	Not Used	Not Used	Not Used	Not Used

Top Drawer — Front

120 TB, Drawer 2 (Bottom) — Initial Media Drive Slot Locations and RAID Groups

Drive Slot 42	Drive Slot 43	Drive Slot 44	Drive Slot 45	Drive Slot 46	Drive Slot 47	Drive Slot 48	Drive Slot 49	Drive Slot 50	Drive Slot 51	Drive Slot 52	Drive Slot 53	Drive Slot 54	Drive Slot 55
Not Used	Not Used	Not Used	Not Used	Not Used	Not Used	Not Used	Not Used	Not Used	Not Used	Not Used	Not Used	Not Used	Not Used
Not Used	Not Used	Not Used	Not Used	Not Used	Not Used	Not Used	Not Used	Not Used	Not Used	Not Used	Not Used	Not Used	Not Used
Not Used	Not Used	Not Used	Not Used	Not Used	Not Used	Not Used	Not Used	Not Used	Not Used	Not Used	Not Used	Not Used	Not Used

Bottom Drawer — Front

Client

The Avid ISIS 2000 systems support 200 ISIS clients using either 1 Gb, dual 1 Gb, and 10 Gb connections at any client Type setting. The client communicates with the drives through the switch to create, modify, and read files stored in the actual drive.

A client uses mechanisms specific to the operating system to display, create, and delete files within the Avid ISIS shared storage network system. For example, when viewed from a Windows operating system, the system sees a server containing many shares that are mapped to drive letters.

CIFS and FTP Clients

The ISIS 2000 also includes a File Gateway providing unlimited Common Internet File System (CIFS) clients, without using Avid ISIS client licenses. This client connection enables network users to access the ISIS Workspaces in a non-realtime scenario. Depending on the access permission, network users can read, write, and delete files on Workspaces without using ISIS client licenses. For instructions on setting up CIFS clients see, [“Configuring the Server for CIFS Access” on page 111](#).



Only System Directors with a 10 Gb connection to the switch support CIFS and FTP clients. When using a 1 Gb connection between the ISIS 2000 System Director and the switch, you must turn off the CIFS service after you have installed the ISIS 2000 software. Disable the CIFS service as described in [“Turning Off the CIFS Service With a 1 Gb Connected System Director” on page 79](#).

A client uses mechanisms specific to the operating system to display, create, and delete files within the Avid ISIS shared storage network system. For example, when viewed from a Windows operating system, the system sees a server containing many shares that are mapped to drive letters. The maximum number of Workspaces that can be shared out as a CIFS share is 22 Workspaces.

You can also configure the System Director to share ISIS Workspaces over the network using the File Transfer Protocol (FTP) function controlled by the Microsoft’s Internet Information Services (IIS) and the FTP Service. For instructions on setting up FTP clients see, [“Configuring the Server for FTP Access” on page 116](#).

Network Zone Configurations

All clients in the shared storage network are classified by zones, depending on how they connect to the network. The following list defines the clients in each network layer by their zone classification:



ISIS 2000 systems typically are integrated with ISIS 7500 / 7000 or ISIS 5500 / 5000 environments. The ISIS 2000 System Director and ISIS 2000 Engine are connected to ISIS 7500 / 7000 or ISIS 5500 / 5000 switches that have been configured with a separate VLAN for the ISIS 2000 components. See your site network administrator for assistance with configuring the separate VLAN on your switch.

- Zone 1 Client — No Zone one client connection is available in ISIS 2000 (direct connect to ISIS 2000 Engine)
- Zone 2 Client — Connected to ISIS VLANs via a 1 Gb or 10 Gb port on an Avid qualified layer-2 switch (non-routed)
- Zone 3 Client — Connected to an Avid qualified layer-3 switch (routed) with known Quality of Service (QoS); traffic routed to ISIS (one hop) and load-balanced across ISIS VLANs (approximately a 60/40 ratio)
- Zone 4 Client — Connected to the house network using an edge or a core switch with unknown QoS; traffic routed to Avid ISIS (measured by the number of hops) and load-balanced across ISIS VLANs (approximately a 60/40 ratio)

Support for different client and device types vary by zone:

- Zone 1 — Not applicable
- Zone 2 — AirSpeed, editors, Interplay
- Zone 3 — Instinct, Assist, certain editors (for example, Avid NewsCutter); typical formats include DV25, DV50/IMX-50, MPEG-2 proxy (2 Mb/s)
- Zone 4 — Instinct, Assist; typical formats include DV25, MPEG-2 proxy (2 Mb/s)

The following four examples show different types of Avid ISIS configurations.

Zone 1 Clients (Direct Connected)

The ISIS 2000 does not provide any client connections directly to the Engine or System Director. Client connections are only available through a switch.

Zone 2 Clients (Indirect Connect) Configuration

Clients that are connected to a switch are referred to as Zone 2 clients. Zone 2 clients are not routed. For a list of supported switches, see the *Avid ISIS ReadMe*.

A Zone 2 configuration consists of a group of clients, connected to an Ethernet switch with a 10-Gb port connected to the ISIS 2000 Engine. The System Director also connects to the switch using a 1-Gb port or 10-Gb port. Each client connects to the ISIS switch using either a 1 Gb or 10 Gb connection.

Avid ISIS Zone 2 Network Configuration

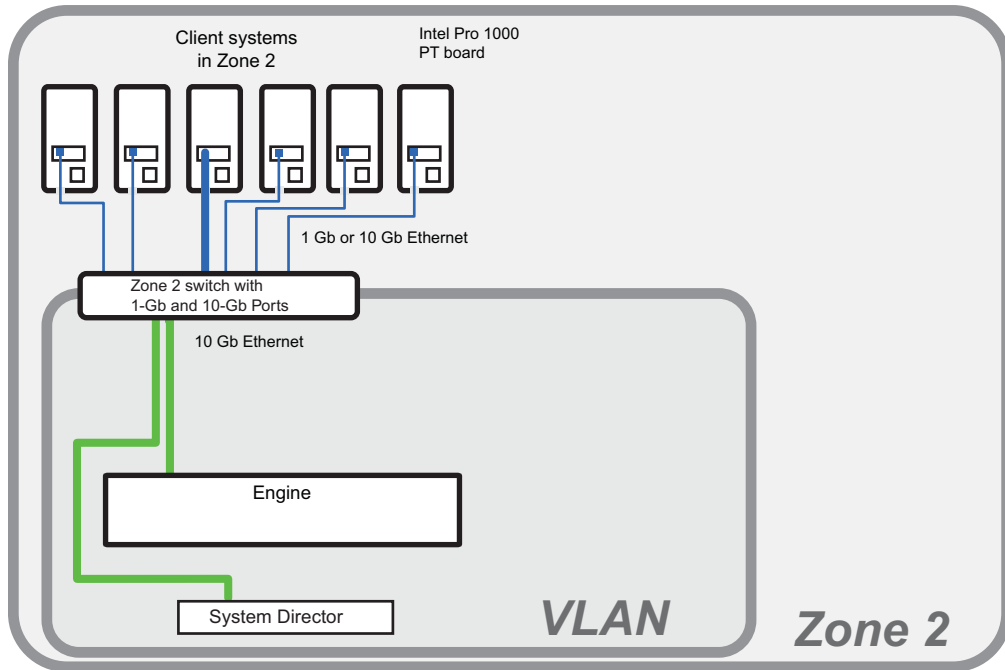

Zone 3 and Zone 4 Client Configuration

A Zone 3 (indirect connect) configuration consists of a group of clients, connected to an Avid qualified layer-3 switch (routed), with known Quality of Service (QoS); traffic routed to ISIS (one hop) and load-balanced across ISIS VLANs (approximately a 60/40 ratio).

A Zone 4 (indirect connect) configuration consists of a group of clients, using an Ethernet switch with unknown QoS; traffic routed to Avid ISIS (measured by the number of hops) and load-balanced across ISIS VLANs (approximately a 60/40 ratio).

The house switch should have uplinks to the Avid Production Network through an Ethernet switch that contains a 10-Gb port connected to the Engines. The ISIS 2000 System Director also connects to the switch using a 1-Gb port or 10-Gb port. The ISIS 2000 can connect to the same APN switches as the primary ISIS 7500 | 7000 or ISIS 5500 | 5000, but must use a different subnet to other ISIS storage systems.

Avid ISIS Zone 3 and Zone 4 Network Configuration

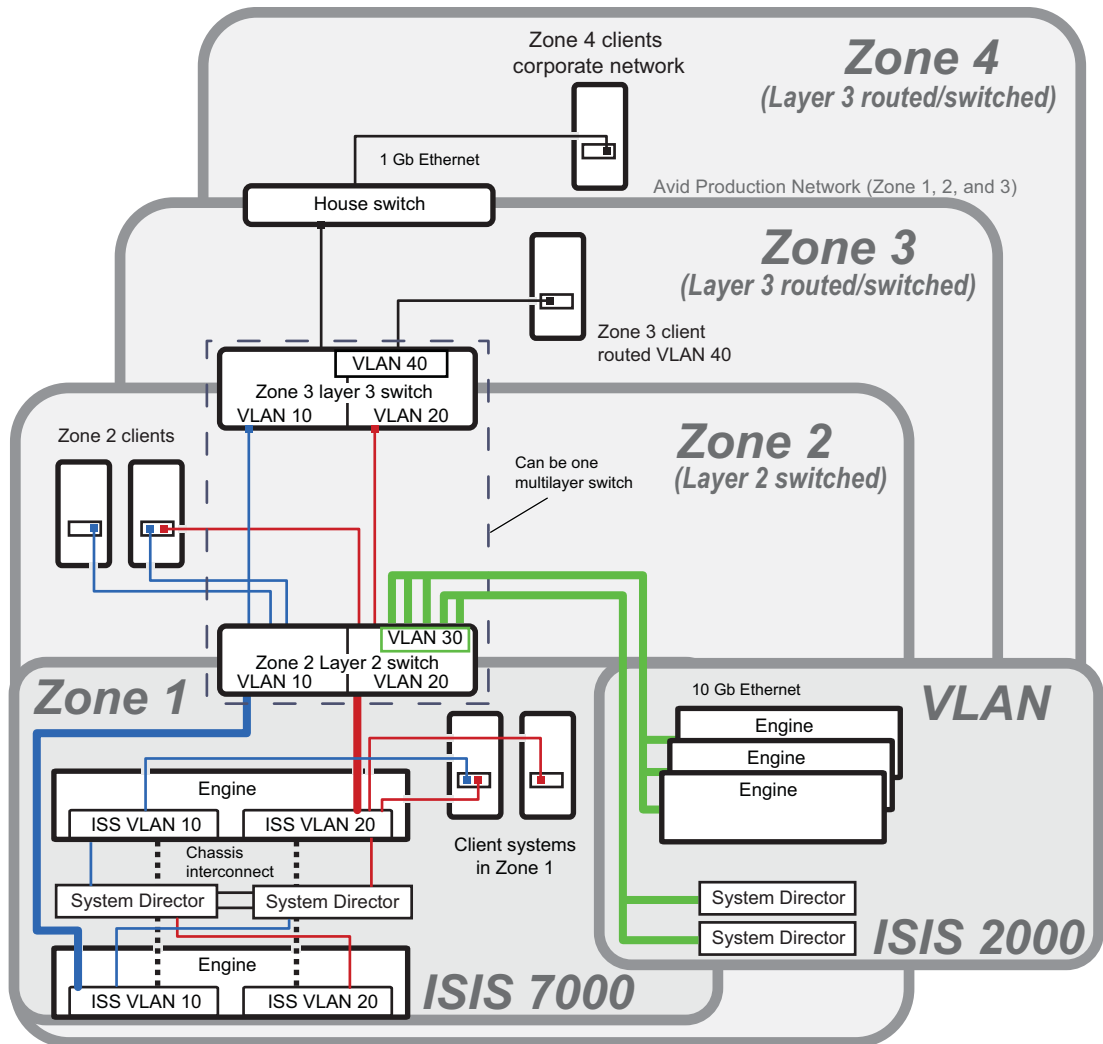

Cabling

For a list of cables qualified with the Avid ISIS system, see [“Supported Cabling” on page 192](#). The following sections provide cabling information you should know when cabling your Avid ISIS stack.

2 Connecting the ISIS Equipment

This chapter explains how to rackmount and connect the system hardware. To do this, a system installation check list is provided to help you perform the installation in the correct order. The installation check list continues past the information in this chapter and points you to the correct area in this document or the ReadMe file to continue the installation.

This chapter contains the following information:

- [Rack-Mounting the Equipment](#)
- [Opening and Closing the Media Drive Drawers](#)
- [Installing the Media Drives](#)
- [Installing the Cooling Modules](#)
- [Installing the Power Supplies](#)
- [Installing the Engine Controller](#)
- [Connecting Power to Equipment](#)
- [Connecting a Keyboard, Monitor, and Mouse](#)
- [Setting-Up the Network Address On the Engine](#)
- [Connecting Network Cables with a 1 Gb System Director Connection](#)
- [Connecting Network Cables with a 10 Gb System Director Connection](#)



For information on connecting and configuring two System Directors for failover, see “Configuring System Director Resiliency” on page 91.

Rack-Mounting the Equipment

This chapter describes how to install and connect the System Director and other workgroup hardware.



Information concerning power and dimensions are provided “Specifications and Notices” on page 190.

Rack-Mounting Example

The following example shows a typical ISIS 2000 rack configuration with a System Director and Engine.

ISIS 2000 System Director and Engine

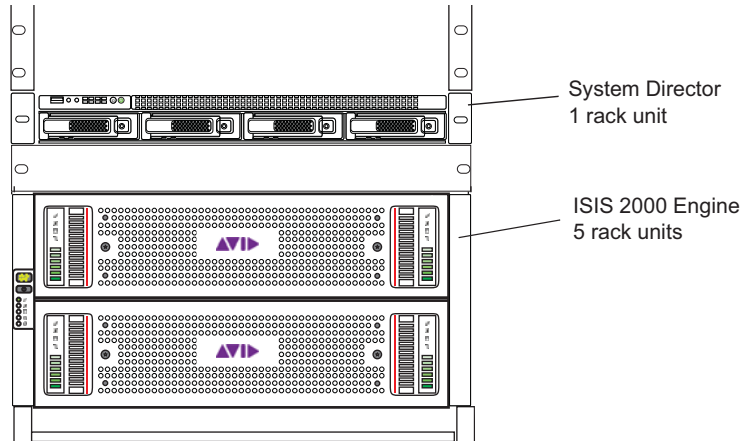

Installing Rack-Mount Rails and Brackets

The System Director is designed for 19-inch (483-mm) rack configurations and requires one EIA rack units (1U), or 1.75 inches (44.45 mm) of rack space. The rail kit installs into rails that are between 23-inches (584.2-mm) to 31-inches (787.4-mm) inches deep. An optional rail kit is available for racks that are up to 37 inches deep.

The System Director includes rack mounting slide rails. If instructions are included with your rail kit, use them instead of the instructions included in this section. The standard rail configuration is for racks with square mounting holes. Optional brackets are included for racks with threaded holes. The rack-mounting kit requires inner slide rails be mounted to the server and the outer slide rails are mounted to the rack. Once both the inner and outer rails are in place, slide the server with the inner rails attached into the outer rails. Secure the server in the front of the rack using the supplied screws so it does not slide forward.



The System Director is designed to be installed horizontally in a rack. Installing the System Director on an angle or in a sloped console causes the internal drives to wear faster than the intended life of the drive.



To ensure the stability of the rack enclosure, start with heaviest equipment installed at the bottom of the rack enclosure. Lighter equipment goes towards the middle and top.

The following are recommendations you should take into account prior to rack-mounting Avid ISIS equipment:

- Avid recommends that you leave a 1U or .5U space between each piece of equipment mounted in the racks. This allows for better airflow and cable access, and helps stop vibration in any equipment being transferred to spaces above and below.



The 1U System Director has vent holes on the top of the enclosure. Avid has performed thermal testing with the top vent holes blocked, and the results indicated that even with the top vent holes blocked, the 1U System Director still operates within the temperature tolerances.

- Avid recommends that you leave an 8 to 12 inch space at the bottom of the rack. This allows for better airflow and lowers the possibility of dust or dirt being picked up by the devices.
- For normal operation, you'll need to maintain approximately 2 feet (0.6 meters) of open space in front of and behind the rack. This allows free access to the components in the rack for operating changes or adjustments. For service, you need approximately 3 feet (1 meter) of open space in front of the rack and 2 feet (0.6 meters) of open space behind the rack. This allows for the removal of any component that needs to be replaced.

Rack-mount Requirements

- **Elevated Operating Ambient** — If installed in a closed or multi-unit rack assembly, the operating ambient temperature of the rack environment might be greater than room ambient. Therefore, consider installing the equipment in an environment compatible with the maximum ambient temperature (T_{ma}) specified by the manufacturer.
- **Reduced Air Flow** — Installation of the equipment in a rack should be such that the amount of air flow required for safe operation of the equipment is not compromised.
Avid ISIS airflow is from the front of the enclosure to the rear. Make allowances for cooling air to be available to the front panel surface and no restrictions at the rear.
- **Mechanical Loading** — Mounting of the equipment in the rack should be such that a hazardous condition is not achieved due to uneven mechanical loading.
Make sure your rack enclosure is stable enough to prevent tipping over when one or more Avid ISIS servers are extended on the sliding rails.
- **Circuit Overloading** — Consideration should be given to the connection of the equipment to the supply circuit and the effect that overloading of the circuits might have on overcurrent protection and supply wiring. Appropriate consideration of equipment nameplate ratings should be used when addressing this concern.
- **Reliable Grounding** — Reliable grounding of rack-mounted equipment should be maintained. Particular attention should be given to supply connections other than direct connections to the branch circuit (for example, use of power strips).
- **Inside Enclosure Access** — If you want to extend the enclosure, and remove the top cover, you must allow 0.5 in (1.3 cm) clearance on top of the enclosure for cover removal.

Positioning the server in the Rack

The following information helps you decide where to install the System Director in the rack.

To position the System Director in the rack enclosure:

- ▶ Select a position in the rack where the System Director is at the proper baseline position.

Positioning the System Director

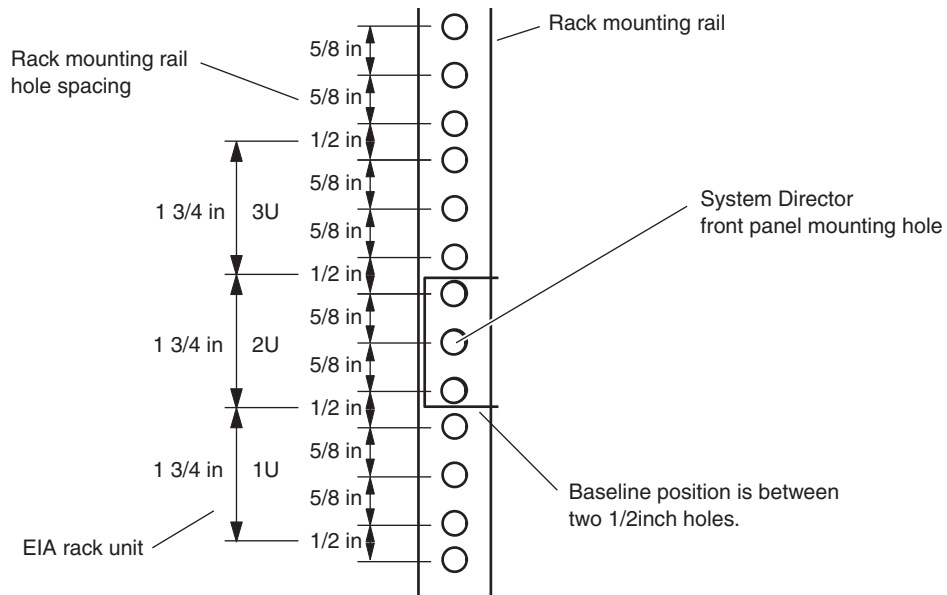

Separating the Slide Rails

You need to separate the slide rails and attach the inner “movable” section to the System Director and the outer “fixed” section to the rack rails.

To separate the slide rails:

1. Slide the slide rail completely open.
2. Press the spring clip on the inner slide rail as shown in the illustration.



The blowup of the spring clip shown in the illustration is on the bottom side of the slide rail.

Separating the Slide Rails

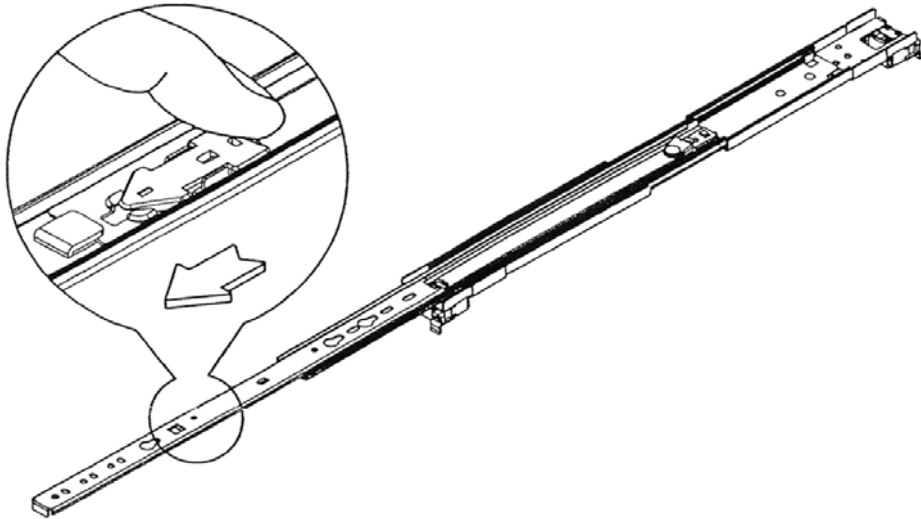

3. Pull and separate the two halves.
4. Repeat these steps to separate the second slide rail.

Attaching Inner Slide Rails to the System Director

Attach the inner slide rails that were separated from the outer slide rails to the System Director.

To attach the inner slide rails:

1. Position the inner slide rail against the side of the server so that the screw holes are toward the rear of the server, and front of the slide rail fits over the tab at the front of the server.
2. Secure the inner slide rail to the server with two of the small screws.



You might find more screws in the rail kit than is needed, and described in this procedure.

Attaching the Inner Slide Rails

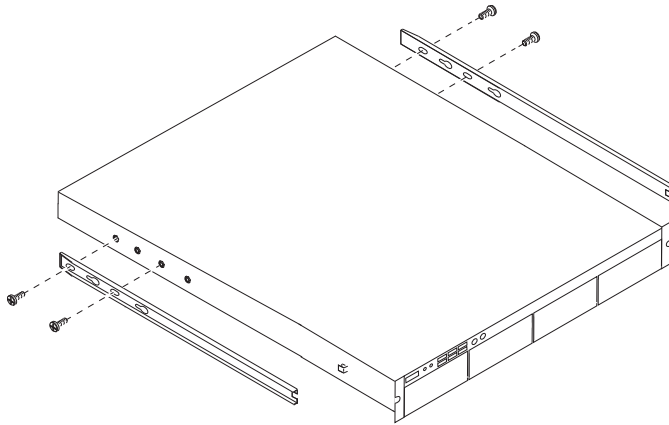

3. Repeat this procedure to attach the other inner slide rail on the other side of the server.

Attaching the Outer Rails to a Square-Hole Rack

After separating the slide rails as previously described (see [“Separating the Slide Rails” on page 35](#)), perform the following procedure. If your mounting rails have threaded holes, see [“Attaching the Outer Rails to a Threaded-Hole Rack” on page 39](#).

To attach the outer slide rails to the rack with square holes:

1. Align the outer slide rail bracket assembly with the front rack-mounting holes.



You should have someone helping you hold the slide rails level while you are positioning them in the rack.

2. Slide the square tabs through the holes in the front, vertical rack-mounting rail.

Positioning the Outer Slide Rail with the Front Rack-Mounting Rail

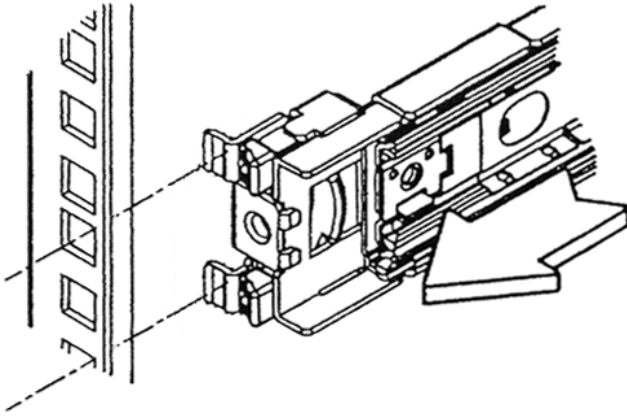

3. Push the outer rail towards the outside of the rack, to secure the outer rail in place

Insert the Outer Slide Rail to the Front Rack-Mounting Rail

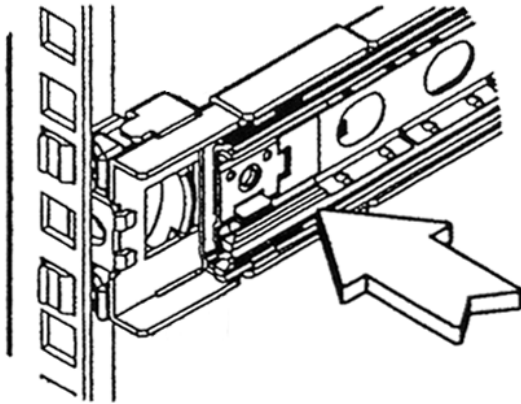

4. Adjust the outer slide rail bracket assembly to the rear mounting rail.
5. Secure the rear outer slide rail bracket assembly to the rear mounting rail as you did for the front rack-mounting rail.

Securing the Outer Slide Rail to the Rear Rack-Mounting Rail

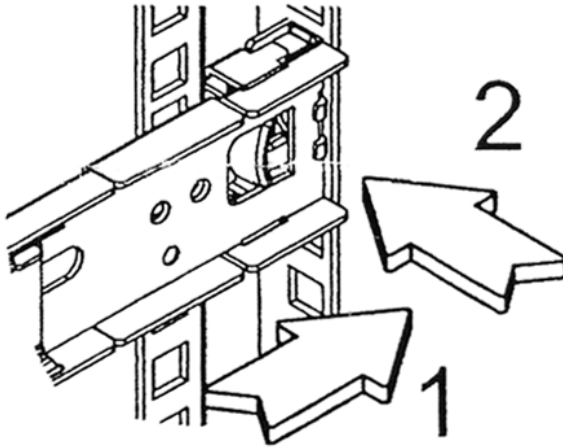

6. Repeat this procedure to attach the second outer slide rail on the other side of the rack.

Attaching the Outer Rails to a Threaded-Hole Rack

After separating the slide rails as previously described (see [“Separating the Slide Rails” on page 35](#)), perform the following procedure. If your mounting rails have threaded holes, you first need to clip on the threaded hole adapter.

To attach the outer slide rails to the rack with threaded holes:

1. Locate the four threaded hole adapters (which ship in the accessory kit's plastic bag, not in the rack mount kit box) and position the adapter on the end of the outer slide rail bracket assembly as shown in the following illustration.

Attaching the Threaded Hole Adapter to the Bracket Assembly

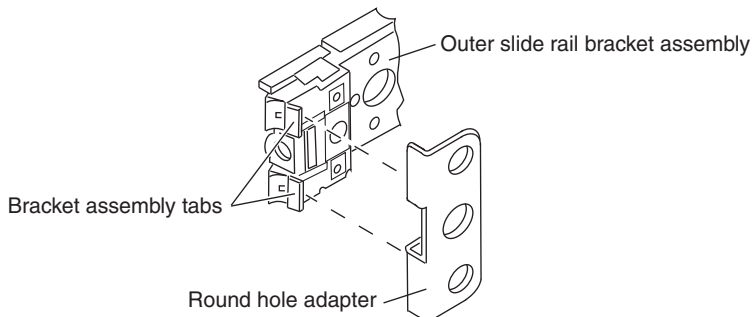

2. With the bracket assembly tabs aligning with the cut-out in the threaded hole adapter, swing the adapter so that the holes face the front of the bracket assembly as shown in the following illustration.

Positioning the Threaded Hole Adapter

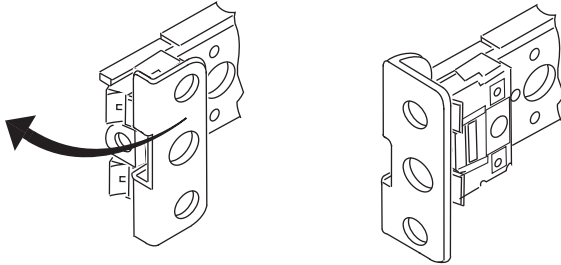

3. Slide the outer slide rail bracket assembly onto the side rack-mounting rail so that the threaded hole adapter is over the rack rail.



You should have someone helping you hold the slide rails level while you are positioning them in the rack.

Insert the Outer Slide Rail to the Front Rack-Mounting Rail

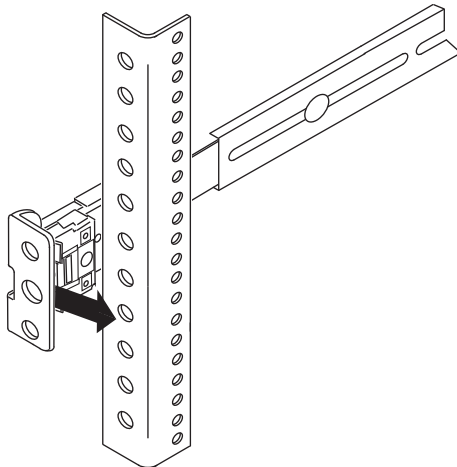

4. Insert the small (10-32) Phillips-head screws through the threaded-hole adapter and mounting rail, into the bracket. If the rack holes are different size, you need to supply your own screws

Securing the Outer Slide Rail to the Rack-Mounting Rail

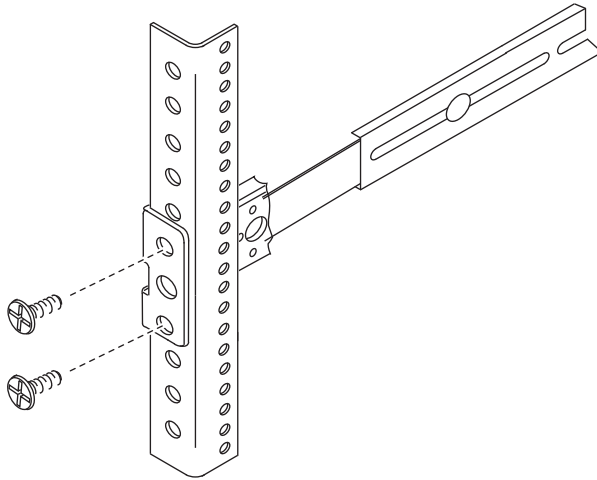

5. Adjust the outer slide rail bracket assembly to the rear mounting rail.
6. Secure the rear outer slide rail bracket assembly to the rear mounting rail as you did for the front rack-mounting rail.
7. Repeat this procedure to attach the second outer slide rail on the other side of the rack.

Securing the System Director in a Rack



You should have someone helping you lift the System Director while you are positioning it into the slide rails.

To secure the server to the rack enclosure:

1. Lift and position the server so that the inner slide rails (secured to the System Director) are aligned with the outer slide rails secured to the rack.
2. Push the front of the System Director server flush against the front mounting rail. The holes in the server front panel align with the holes in the front mounting rail.
3. From the front of the rack enclosure, insert the large Phillips-head screw through the System Director and front mounting rail.
 - Square hole racks — the middle hole of the outer rail kit is where the screw anchors the server front panel to the vertical rail. A M6x10 screw in the parts kit is included to secure the front panel with square hole racks.
 - Threaded hole racks — the server front panel attaches to the vertical rail of the rack. Use a truss head screw or hardware that come with your rack to secure the front panel with threaded hole racks.

Front Panel Screws

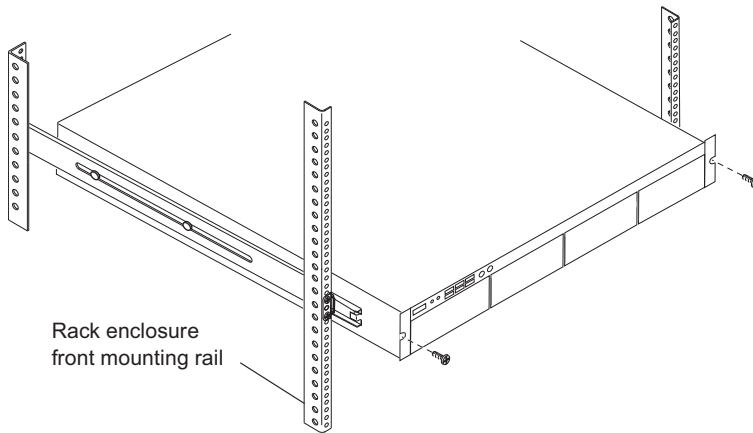

Mounting the Engine

The ISIS 2000 Engine is designed for 19-inch (483-mm) rack configurations and requires five EIA rack units (5U), or 8.75 inches (222.25 mm) of rack space. The ISIS 2000 rackmount rails are designed for racks with square or threaded holes. This procedure focuses on racks with threaded holes. Additional instructions are included on a decal located on the side of one of the bracket rails.



Do not lift the Engine by the handles on the power supply units, cooling modules or Engine Controllers – they are not designed to take the weight.



Lifting the Engine with the drives, cooling modules, and power supplies installed can cause an injury. The Engine must have all modules and drives removed prior to lifting. Avid recommends that two people be used whenever lifting the empty Engine.

To mount the Engine into the rack:

1. (Option) If using racks with threaded holes, you need to unscrew and remove the five round pegs on each end of the bracket rail.

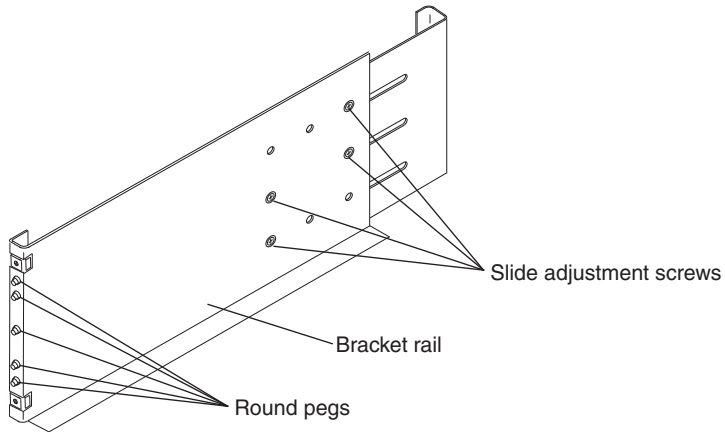

2. Loosen the four slide adjustment screws so that the bracket rail side allows you to adjust the bracket rail to the depth of your rack.

The adjustment screws are highlighted in a colored circle around the screw.

3. Position the bracket rail between your rackmount rails and adjust the length of the bracket so that it meets the inside of both the front and rear rails as shown in the following figure.

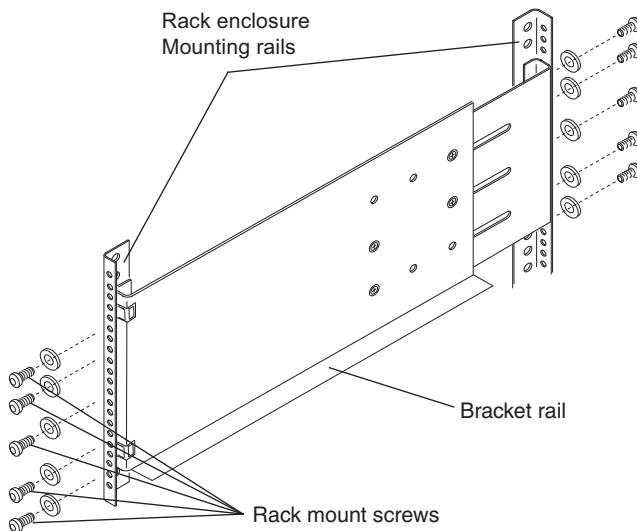

- Secure the bracket rail to the front and rear mounting rails using either the screws that come with the rack mount kit or your rack screws (five screws in the front and the rear).



Leave the top most holes on the front of the rail empty so you can use those holes to screw through the ears on the Engine to keep it from sliding forward once racked.

- Tighten the four slide adjustment screws.
- Repeat steps 1 through 5 to install the other bracket rail on the opposite side of the rack.
- Make sure that the media drives are not installed in the Engine.
- Using two people, lift the Engine and place the rear of the Engine onto the brackets as shown in the following figure.

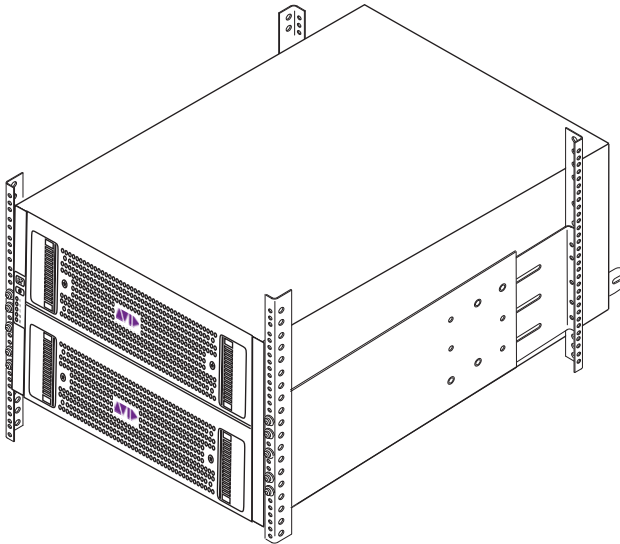

- Position the bracket extender on the outside of the rear mounting rail so that the sliding nut in the bracket extender inserts into the rack mounting tab on the Engine. Using the short screws included in the rack mount kit, secure the bracket extender to the rack mounting tab on the Engine as shown in the following figure.

The rack mount kit provides two sets of bracket extenders: a long pair and short pair. Use the pair of bracket extenders that are most appropriate for your rack. Racks with less depth, would need the longer bracket extenders.

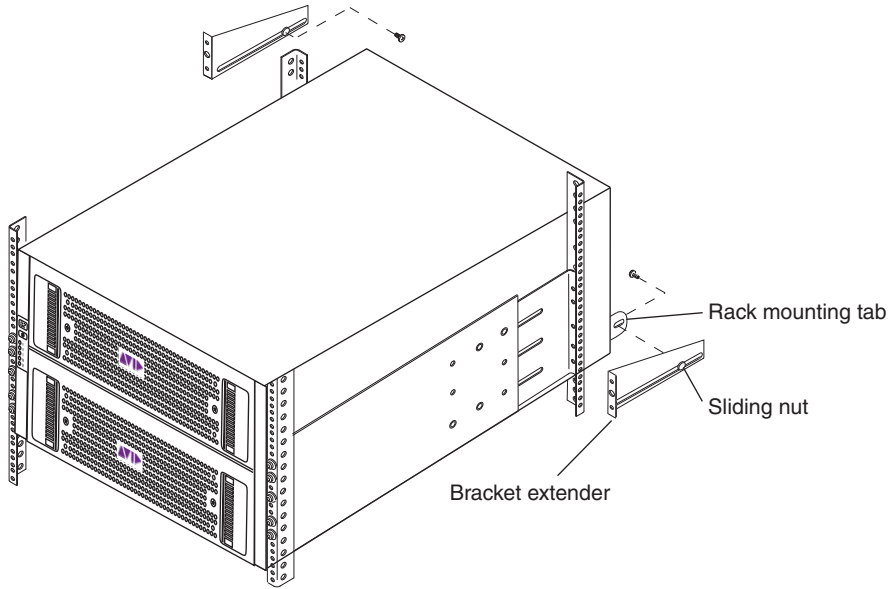

10. Screw the front of the Engine to the front of the rack through top and bottom holes of the plastic end caps on each side of the Engine as shown in the following figure using the screws included in the rack mount kit.

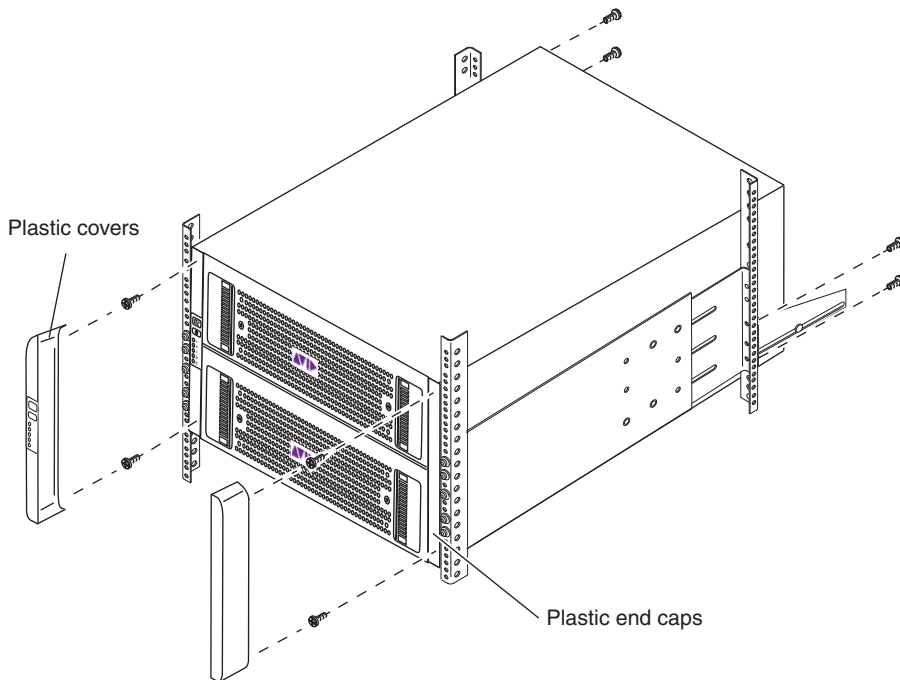

11. Secure the rear stabilizer brackets to the rear rackmount rails through top and bottom holes in the extender bracket as shown in the preceding figure using the screws included in the rack mount kit or your rack screws.
12. Snap the left and right plastic covers over the plastic end caps on the front Engine as shown in the preceding figure.

Opening and Closing the Media Drive Drawers

This section covers how to open the media drive drawer and replace a media drive. The procedure is the same for both drawer 1 and drawer 2.



To ensure the stability of the rack enclosure, The Engine includes a mechanism that only allows one drawer to be open at a time. If both drawers were open at the same time, there is a risk that the rack could tip.

To open a drive drawer:

1. Make sure the anti-tamper locks are not engaged. The red arrows on the locks will point inwards if the locks are disengaged. Unlock them if necessary by rotating them counterclockwise using a screwdriver with a Torx T20 bit.



2. Push the drawer latches inward and hold them.
3. Slowly pull the drawer all the way out until it locks open.

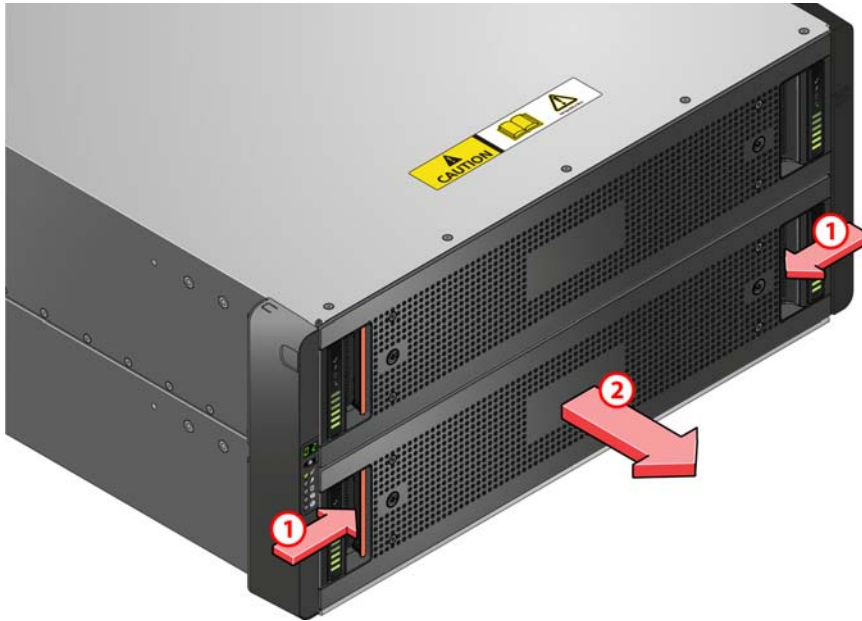

To close a drive drawer:

1. Pull and hold both of the white latches on the sides of the drawer.



You might need to pull the drawer completely open before pulling the white latches.

2. Push the drawer in slightly.
3. Release the white latches.
4. Slowly push the drawer all the way back into the Engine, making sure it clicks in place.



Take care not to push the drawer in hard or to slam it shut, doing so could potential damage the drives or the drawer.

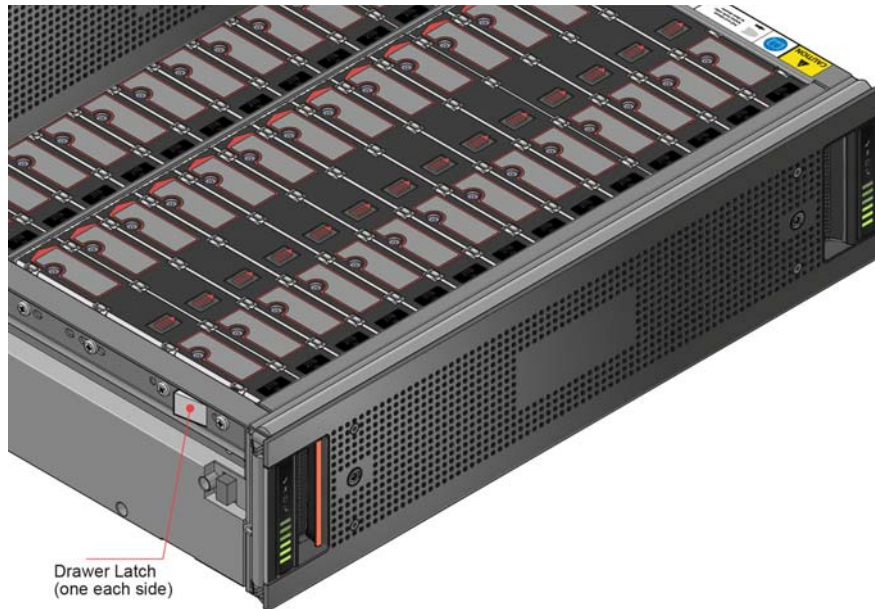

Installing the Media Drives

This section describes how to install a media drive. The procedure for installing the media drives is the same for both drawer 1 and drawer 2. The location on where the media drives get installed is different between the two ISIS 2000 Engine configurations.

- ISIS 2000-240 Media Drive Configuration (1 Engine, with 82 drives) — There are 41 drives in each drawer.
- ISIS 2000-120 Media Drive Configuration (1 Engine, with 42 drives) — There are 28 drives installed in the front-most slots of the top drawer. The last 14 drives are installed in the front-most slots of the bottom drawer.



The ISIS 2000-120 media drive configuration is mandatory. You must install the drives in the slots specified, This is an air-flow requirement and is enforced with the software.

To insert a media drive:

1. Make sure the anti-tamper locks are not engaged. The red arrows on the locks will point inwards if the locks are disengaged. Unlock them if necessary by rotating them counterclockwise using a screwdriver with a torx T20 bit.
2. If the appropriate drawer is not already open, open it using the instructions in section Opening and Closing the Media Drive Drawers.
3. Lower the Media Drive into the slot, with the drive capacity label facing towards you.

4. Push the media drive downwards and hold it down while sliding the drive carrier plate in the direction shown in the following figure. This locks the drive in place.

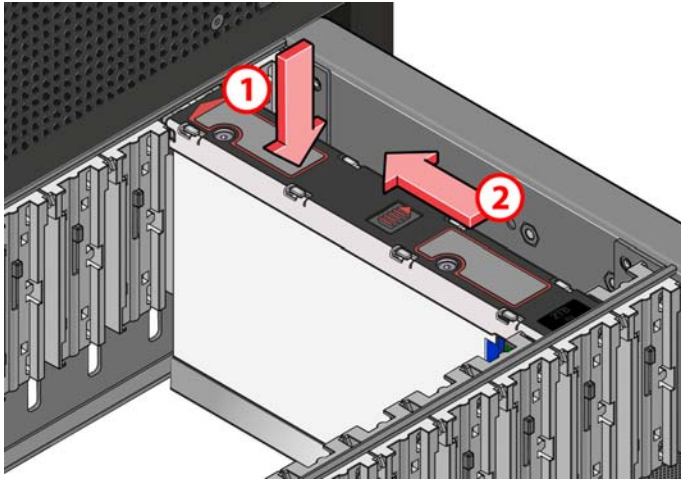

5. Repeat this procedure to install the remaining media drives in the open drawer as follows; depending on your ISIS 2000 Engine configuration.
- ▶ ISIS 2000-240 — using the following illustration, populate 41 media drives in each drawer. Do not populate the Drive 0 and Drive 42 slots. For more information on drive slots, see [“ISIS 2000-240 Media Drive Configuration” on page 25](#).
 - ▶ ISIS 2000-120 — using the following illustration, populate 28 media drives in the front-most slots of the top drawer (drive slots 0 to 27). Populate 14 media drives in the front-most slots of the bottom drawer (drive slots 42 to 55). For more information on drive slots, see [“ISIS 2000-120 Media Drive Configuration” on page 26](#).



Do not open both drawers simultaneously.

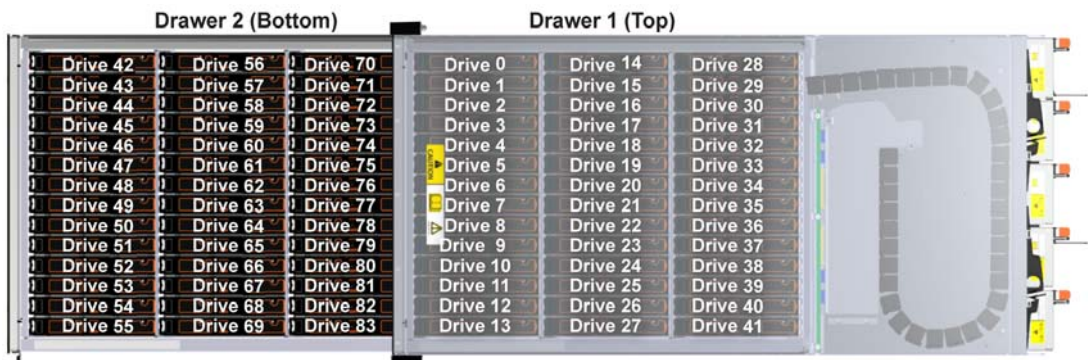

6. After populating one drawer, close it and populate the second drawer, see “Opening and Closing the Media Drive Drawers” on page 46.

Installing the Cooling Modules

This section describes how to install the cooling module.

To insert a cooling module:

1. Position the cooling module so that the red release latch and handle are on the right-hand side.
2. Slide the cooling module into its slot until the latch clicks in place.

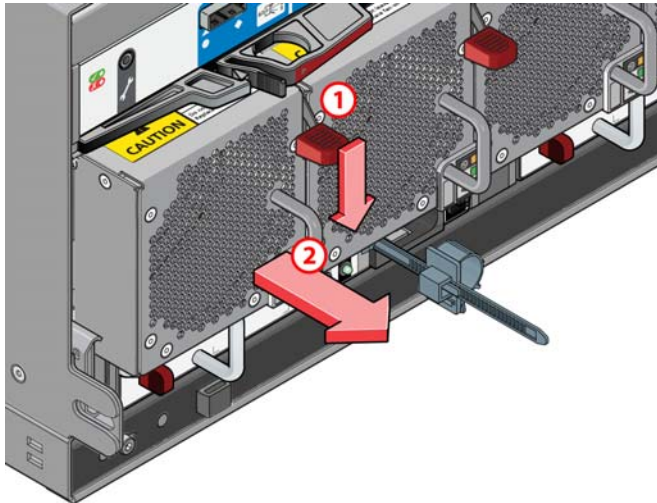

3. Repeat this procedure to install the remaining four cooling modules into the cooling module slots.

Installing the Power Supplies

This section describes how to install the power supplies.

To insert a power supply:

1. Position the power supply so that the red release latch and handle are on the left-hand side.
2. Slide the power supply into its slot until the latch clicks in place.

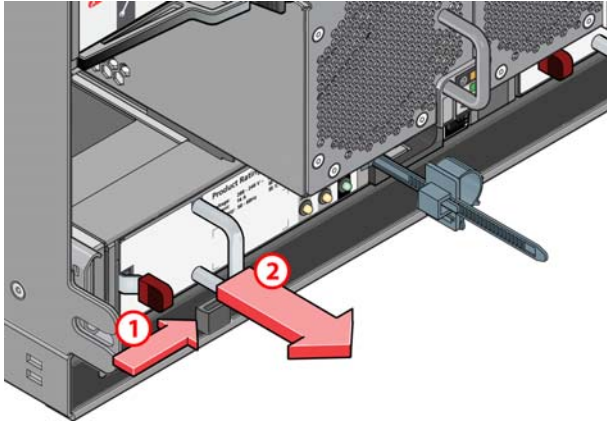

3. Repeat this procedure to install the second power into the second power supply slot.

Installing the Engine Controller

This section describes how to install the Engine Controller.



The Engine Controller must be in the left slot (when viewed from rear of Engine). The software does not run if Engine Controller is in the right slot.

To insert an Engine Controller:

1. Position the Engine Controller so that the release latch is at the bottom.
2. Open the release latch and rotate it to its most open position.
3. Slide the Engine Controller into its slot until it will go no further.
4. Close the latch until it clicks in place. This will lever the module into its connector on the midplane. The Engine will automatically detect the new unit.



The Engine Controller shown in the illustration is for reference only, the actual Engine Controller used in the ISIS 2000 Engine varies from the model shown in the picture.

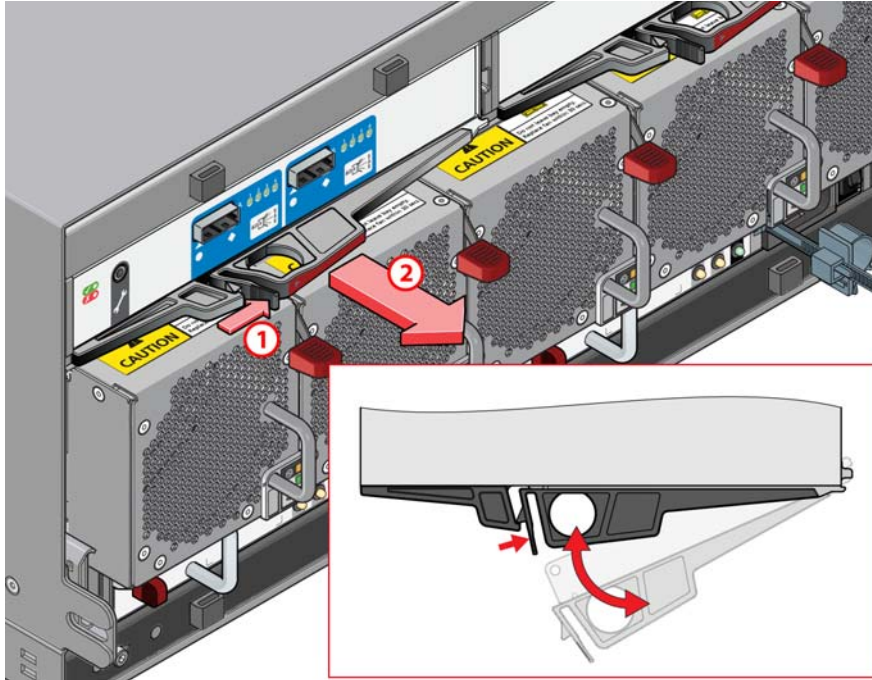

Connecting Power to Equipment

The Avid ISIS 2000 System Director and Engine include each two power supplies for redundancy. At least one of the power supplies must be operational for the either the System Director or Engine to function. If a power supply fails, leave it in place until you have a replacement. The System Director and Engine can each operate on one power supply, but you are running in an unprotected mode.

The ISIS 2000 Engine cooling modules provides airflow for the Engine. A failed module should be left in place until a replacement is available in order to ensure proper airflow is maintained.

The power cable that comes with the ISIS 2000 Engine is a C19 to C20 power cable. The C19 end is a female connector which plugs into the power supply on the Engine. The C20 end is a male connector, used to plug into a Power Distribution Unit (PDU) with C19 style connectors.

An example of a PDU is the APC® Basic Rack PDU with C19 208-240V outputs and a twist lock NEMA LP6-30 input:

http://www.apc.com/products/resource/include/techspec_index.cfm?base_sku=AP9570



Avid is not recommending any specific vendor or model of PDU. A PDU is a rackmount ready, high current power strip that can offer a variety of plug types. Purchase a model that suits the needs of the equipment in your rack.

Each ISIS 2000 Engine power supply draws a maximum of 13 amps of current using 220 Vac. Each power supply in the Engine should be connected to a different 30-amp circuit. This allows the system to continue running if one of the two circuits fail.

Each System Director has two power supplies rated at 5.8 amps each. Avid recommends each power supplies be on a separated 20-amp circuit.

Connecting Power Cords

When using two circuits for the System Director and Engine they should be configured as follows:

To connect the power cords to the System Director and Engine:

1. Plug two power cords into the back of the System Director and then plug the other ends into 120v power outlets on separate circuits.
2. Plug two power cords into the back of the Engine and then plug the other ends into 220v power outlets on separate circuits.

Power Connections

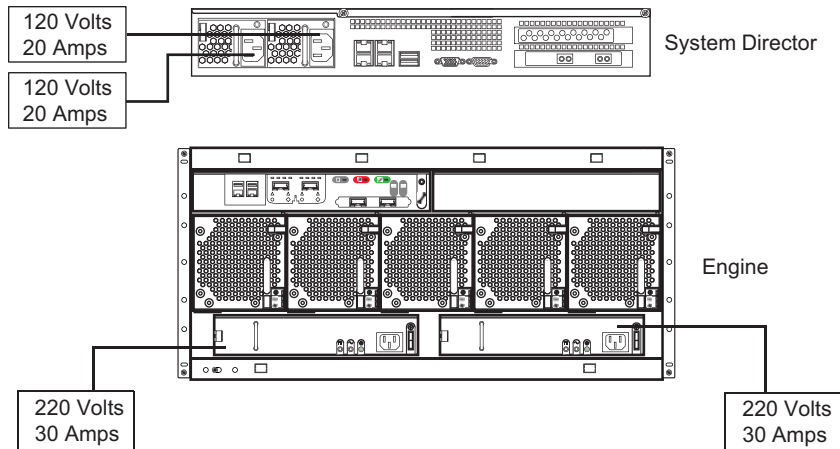

Turning System On and Off

To turn the ISIS system on or off, use the following order. Do not turn off the Avid ISIS components until they have completely powered on.

To turn your system on:

1. Turn on the Engine by switching the power switch to the on position on each power supply module. Allow enough time for the lights on the front panel to turn Green.
2. Turn on the System Director.
3. Clients should restart their systems and use the Client Manager software to log on and mount workspaces.

To turn your system off:

1. Exit the Client Manager on all clients.
2. Stop the System Director service using the System Director Control Panel.
3. Turn off the System Director.
4. Turn off the Engine using the switch on the power supply module.

Connecting a Keyboard, Monitor, and Mouse

An industry standard USB keyboard, USB mouse and VGA monitor are used to access the System Director. When installed in a rack with several servers an optional KVM switch can also be used. The keyboard, monitor, and mouse connections use the same ports described in the following procedure. Follow the instruction supplied with your KVM switch. You need to supply KVM cables that are compatible with your KVM switch.



There are only two USB ports on the rear of the System Director. When you purchase your KVM, consider a USB splitter cable so that both your keyboard and mouse can plug into the splitter cable and use a single USB port on the System Director.

To connect a keyboard, monitor, and mouse to the Avid ISIS:

1. Install your KVM switch in a suitable slot next to the System Director in the rack.

You can also place the monitor on a shelf, and the keyboard and mouse on a sliding tray in the rack. These items are optional and can be purchased locally or from Avid.

**Do not place the monitor on top of the Avid ISIS.**

2. Attach the VGA connector on the monitor cable to the 15-pin video port on the back of the Avid ISIS. Secure the connector with the thumbscrews on the connector. For exact locations see “[System Director Rear Panel](#)” on page 17.
3. Insert the connector on the keyboard and mouse cables into a USB splitter cable.



If you do not have a USB splitter cable, plug your keyboard and mouse cables directly into the USB ports on the rear of the System Director.

4. Insert the other end of the USB splitter cable into a USB connector on the back of the System Director.

Setting-Up the Network Address On the Engine

The following procedure describes how to configure the Engine.

To configure the engine:

1. Ensure the Engine has been powered on.
You should allow about 2 minutes for the Engine to reach a ready status.
2. Power on the System Director.
3. You are asked for the user name and password. Type **administrator** for the user with a password of **is-admin**.



The System Director password is preset to is-admin. The System Director Management Console Web Page Administrator user whose default password is blank.

The following static IP addresses have been pre-configured on the ISIS 2000 Engine.

- IP addresses 192.168.0.10
- Subnet mask 255.255.255.0



Make sure no DHCP servers are assigning addresses in the Avid ISIS range.

4. Using a System Director (or computer running a Windows operating system), assign a static IP address of 192.168.0.11 to the 1 Gb Management Port of the System Director and attach it to the management port of the Engine (left 1 Gb port on Engine Controller).

The following example shows the physical connection between a System Director and Engine for configuring the IP Address of the Engine Controller.

System Director 1 Gb and Engine 1 Gb Management Ports Connections

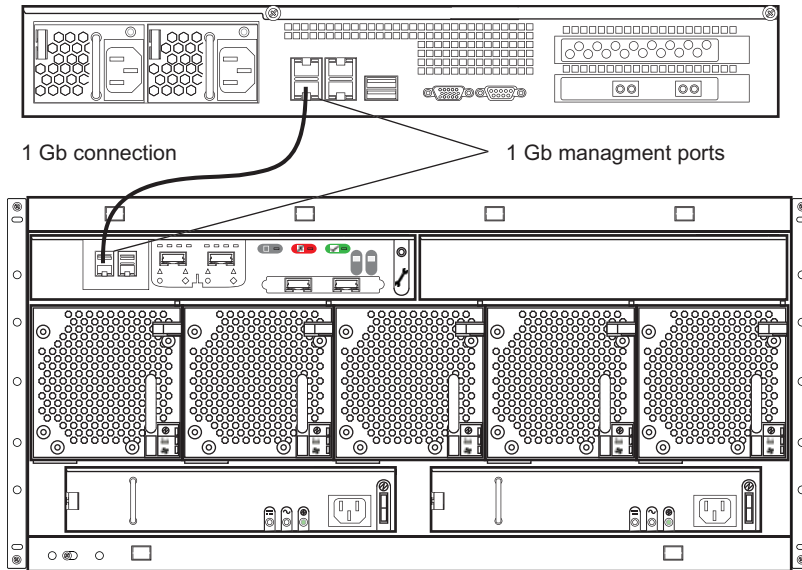

5. Open a browser and navigate to the ISIS 2000 Storage Manager Agent Web page via the following address: <https://192.168.0.10:5015>.
6. You are asked for the password. Type **se-admin**.
7. Click Network in the left pane of the System tab.
The ISIS 2000 Storage Manager Agent page appears.

Avid ISIS Storage Manager
192.168.0.10 / ISIS2000_Eng1

System | Statistics | Tools | Logging | Advanced

System

Status

Configuration

► Network

Time

Administration

Versioning

Show Version Information

Basic Network Configuration

Hostname:

Default Gateway:

Data Interfaces

	Address	Netmask	Description
gx0	<input type="text" value="192.168.0.02"/>	<input type="text" value="255.255.255.224"/>	10 Gbps Left

Management Interfaces

	Address	Netmask	Description
ge0	192.168.0.10	255.255.255.0	1 Gbps Left

Other Interfaces

	Address	Netmask	Description
ge1	0.0.0.0	0.0.0.0	1 Gbps Right
gx1	0.0.0.0	0.0.0.0	10 Gbps Right

8. Type the following into the Basic Network Configuration window:

- Type the Hostname you want for you Engine Controller.
- (Option) If using a Gateway, select the Default Gateway checkbox and enter the IP addresses of your default gateway.

If you are going to be using a Zone 3 environment you must set the default gateway addresses for the Engine. These addresses must come from the site's IS department.



Make sure no DHCP servers are assigning addresses in the Avid ISIS range.

- Enter an IP addresses and Netmask address in the Data Interfaces in the gx0 text boxes.

9. Click Submit.

A dialog box might appear with an informational warning to restart the Engine; click the restart button, enter the “se-admin” password, and the system will restart.

10. Return to the ISIS 2000 Storage Manager Agent page again and click Time in the left pane of the System tab and do one the following.
 - ▶ If using a network time servers, enter the IP addresses of your network time servers.
If your network has a network time protocol (NTP) server, you can enter the IP address of that server in the Chassis Configuration window. NTP Server 1 is for the primary NTP server and if you have a secondary NTP server, enter the secondary IP address in NTP Server 2.
 - ▶ If not using a network time server, manually enter the Date, Time, and Time Zone or Enable network time protocol.
11. Click Submit.
A dialog box might appear with an informational warning to restart the Engine; click the restart button, enter the “se-admin” password, and the system will restart. The Engine is now properly addressed.
12. Assign appropriate static IP address to the network port of the System Director.
13. Attach the System Director to the switch and verify that you can ping the System Director from another system on the network.

Connecting Network Cables with a 1 Gb System Director Connection

Connect the ISIS 2000 System Director with a 1 Gb cable and the Engine with a 10 Gb Ethernet cable to the switch as described in this section.



Only System Directors with a 10 Gb connection to the switch support CIFS and FTP clients. When using a 1 Gb connection between the ISIS 2000 System Director and the switch, you must turn off the CIFS service after you have installed the ISIS 2000 software. Disable the CIFS service as described in Turning Off the CIFS Service With a 1 Gb Connected System Director.



The network switch used in the illustrations in the section is the Force10 S4810 switch. For an up-to-date list of ISIS 2000 switches, see the Avid ISIS ReadMe.

To cable the ISIS 2000 system using 1 Gb port:

1. Connect a CAT 5e or CAT 6 Ethernet cable to the lower right-hand 1 Gb port on the rear of the System Director. No other 1 Gb port on the System Director has been configured for this connection.

System Director's 1 Gb Connection

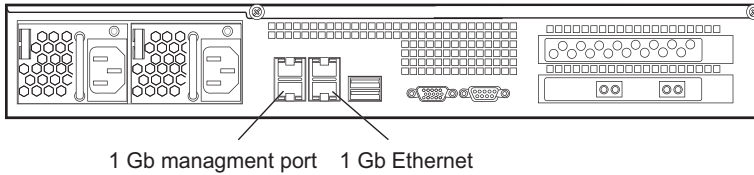

2. Connect the other end of your network cable to the appropriate port on your ISIS 2000 switch.

The following example shows the physical connections between a System Director, Engine, and a Force10 S4810 switch.

System Director 1 Gb and Engine 10 Gb Network Connections to Switch

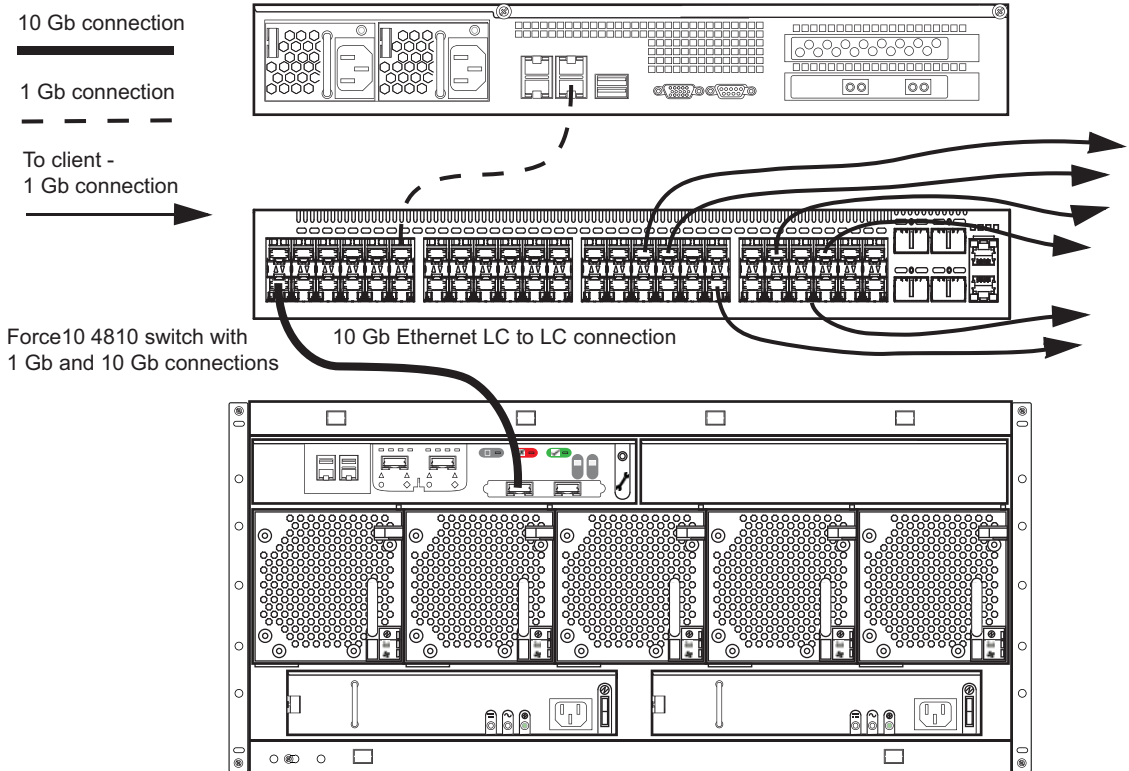

3. Connect a 10 Gb optical network cable to left 10 Gb port (as seen from the rear of the Engine) on the Engine Controller of the ISIS 2000 Engine. No other 10 Gb port on the Engine has been configured for this connection.

The 10 Gb port on the ISIS 2000 Engine Controller requires an SFP+ transceiver. When using SFP+ transceivers, Short Range (SR) is the preferred choice over Long Range (LR).

4. Connect the other end of the 10 Gb network cable to a 10 Gb port on your ISIS 2000 switch. Depending on the type of switch you have, an X2 or SFP+ transceiver might be needed for the switch port.



The Force10 S4810 switches need SFP+ transceivers with an LC to LC cable connection. The Cisco 4900M switches need an X2 transceiver for the SC type connector with an LC to SC cable connection.

5. When using a 1 Gb connection between the ISIS 2000 System Director and the switch, you must turn off the CIFS service after you have installed the ISIS 2000 software.
 - a. The first time you set up the ISIS 2000 Engine you must connect to the Management port to on the Engine Controller to configure the IP address, see [“Setting-Up the Network Address On the Engine”](#) on page 55.
 - b. Install the ISIS 2000 software as described in Loading the Software.
 - c. Disable the CIFS service as described in Turning Off the CIFS Service With a 1 Gb Connected System Director.

Connecting Network Cables with a 10 Gb System Director Connection

Connect the ISIS 2000 System Director and Engine to the switch using 10 Gb Ethernet cables as described in this section.

Depending on the type of switch you have, an X2 or SFP+ transceiver is needed for your 10 Gb port connections. When using SFP+ transceivers, Short Range (SR) is the preferred choice over Long Range (LR). The 10 Gb ports on the System Director and the Force10 S4810 switches need an SFP+ transceiver for LC type connectors. The Cisco 4900M switches need an X2 transceiver for SC type connectors. For more information on ISIS cables and transceivers, see [“Supported Cabling”](#) on page 192.



The network switch used in the illustrations in the section is the Force10 S4810 switch. For an up-to-date list of ISIS 2000 switches, see the Avid ISIS ReadMe.

To cable the ISIS 2000 system:

1. Connect an optical cable to the 10 Gb port on the System Director.
 - a. Insert an SFP+ transceiver into either 10 Gb Ethernet connector in the Avid ISIS 2000 System Director.
 - b. Connect the optical cable into the SFP+ transceiver you inserted into the 10 Gb port on the ISIS 2000 Engine.

System Director's 10 Gb Connection with SFP+ Transceiver

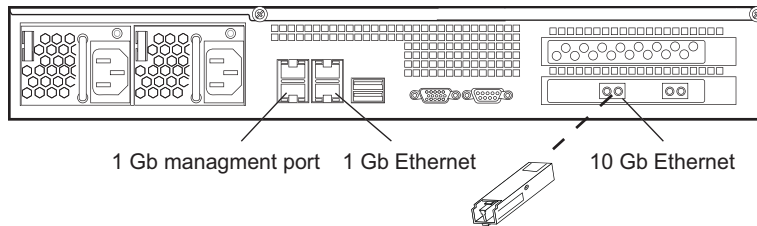

2. Connect the other end of your network cable to the appropriate port on your ISIS 2000 switch.

Depending on the type of switch you have, an X2 or SFP+ transceiver might be needed for the switch port.



The Force10 S4810 switches need SFP+ transceivers with an LC to LC cable connection. The Cisco 4900M switches need an X2 transceiver for the SC type connector with an LC to SC cable connection.

The following example shows the physical connections between a System Director, Engine, and a Force10 S4810 switch.

System Director and Engine 10 Gb Network Connections to Switch

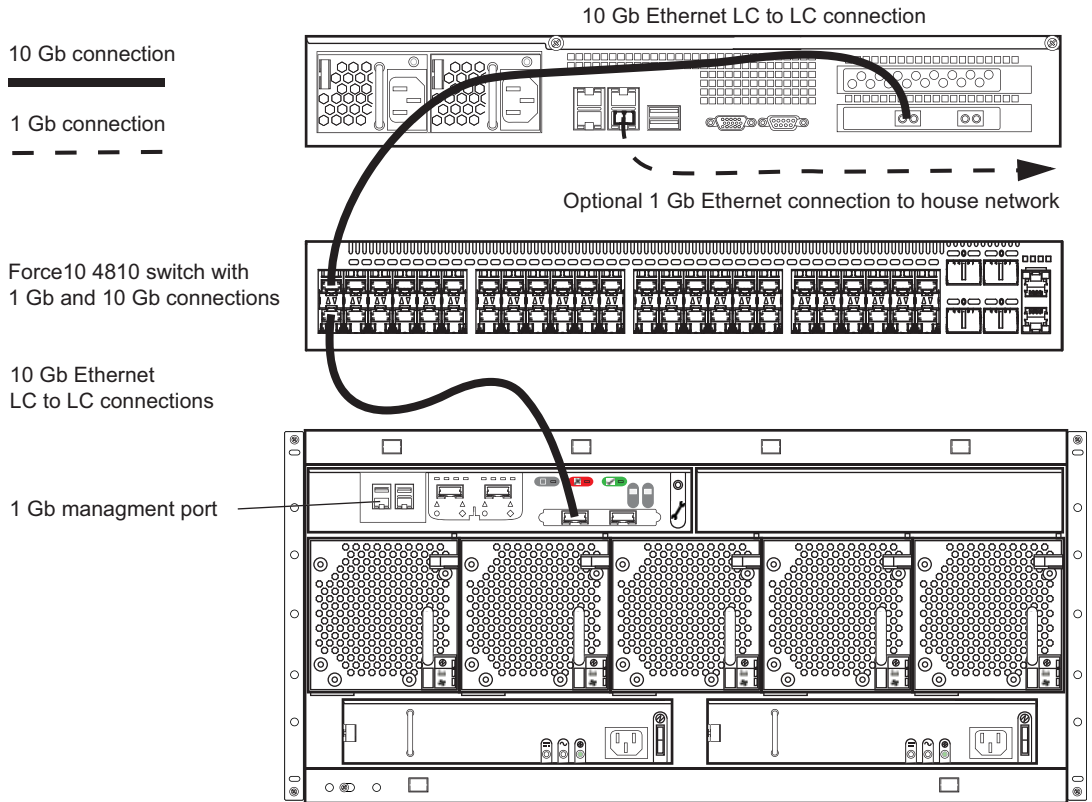

3. Connect a 10 Gb optical network cable to left 10 Gb port (as seen from the rear of the Engine) on the Engine Controller of the ISIS 2000 Engine. No other 10 Gb port on the Engine has been configured for this connection.

The 10 Gb port on the ISIS 2000 Engine Controller requires an SFP+ transceiver.

4. Connect the other end of the 10 Gb network cable to a 10 Gb port on your ISIS 2000 switch.
Depending on the type of switch you have, an X2 or SFP+ transceiver might be needed for the switch port.



The Force10 S4810 switches need SFP+ transceivers with an LC to LC cable connection. The Cisco 4900M switches need an X2 transceiver for the SC type connector with an LC to SC cable connection.

5. Repeat steps 3 and 4 if connecting a multiple ISIS 2000 Engines (up to five ISIS 2000 Engines are supported).

6. Finish the setup as follows:
 - a. The first time you set up the ISIS 2000 Engine you must connect to the Management port to on the Engine Controller to configure the IP address, see [“Setting-Up the Network Address On the Engine”](#) on page 55.
 - b. Install the ISIS 2000 software as described in Loading the Software.

3 Installing Software and Configuring

This chapter describes how to connect and configure the System Director and other Avid ISIS hardware.

If you have questions, please call your Avid representative or your local ACSR.



Before you start the procedures in this chapter, you should be familiar with the information in previous chapters and the *Avid Network and Switch Guide*.

This chapter contains the following sections:

- [Software Installation](#)
- [Adding a Remote Host for Zone 3 and 4 Clients](#)
- [Avid Interplay Authentication](#)

Software Installation

Your System Director and Engine should be cabled and attached to an ISIS network switch. to both internal subnets similar to the [“Connecting Network Cables with a 10 Gb System Director Connection”](#) on page 60.

If you are upgrading an existing ISIS 2000 to the latest version of ISIS software, see [“Avid ISIS 2000 Upgrade Guidelines”](#) on page 123.

Configuration Overview

The following list summarizes the System Director and Engine setup.

1. Assign an IP addresses to your Engine, see [“Setting-Up the Network Address On the Engine”](#) on page 55.



The ghost image on the System Directors does not set the IP addresses of the onboard network ports or the dual 10 Gb network ports on the PCI bus; the system is set for DHCP.

2. Load the System Director software. This software is used to create a file system on the System Director, bind the drives to the software on the System Director, create Storage Groups, and administer the Avid ISIS system. See [“Loading the Software”](#) on page 65.

3. Perform administrative functions: bind Engines (Storage Elements), create Storage Groups, and do other administrative functions. See “[Creating an Active File System on the System Director](#)” on page 71.
4. Load the client software; see “[Loading Client Software](#)” on page 82.

Loading the Software

The System Director software is loaded onto the System Director using a USB flash drive. The system ships with two USB flash drives:

- One USB flash drive is your Avid ISIS software installation kit.



Any USB flash drive is supported for loading the software kit as long as it has at least 2 GB of storage.

- The second USB flash drive is used as a bootable USB flash drive with Avid ISIS Product Recovery image.

To load the Avid ISIS software:

1. Log in to the System Director as Administrator (default password: **is-admin**).



The Avid ISIS 2000 product documentation is in PDF format. You can access the documentation in the AvidISISDocumentation folder on the Avid ISIS installer kit. You need to download and install Acrobat Reader on your Avid ISIS 2000 before you can access the PDF documentation.

2. Make a folder for the software kit on your root directory (C:\) of your System Director.
3. Insert the USB flash drive with software kit into any of USB ports on your System Director.



You can run the software installer from the USB flash drive. The advantage of copying the software kit to the Avid ISIS is that you have easy access to kit files if you should ever need them in the future.

- a. Double-click the computer icon on the desktop.
 - b. Double-click the USB flash drive icon in the window and copy the software kit into the new folder you created on the Avid ISIS 2000 system.
4. (Option) The Avid ISIS 2000 software kit is also available on the Avid Download Center (www.avid.com/support/downloadcenter). Uncompress (unzip) the downloaded software kit in the new folder on the Avid ISIS 2000 system.
 5. Double-click the Autorun.exe file in the software kit.

The installer splash screen appears.

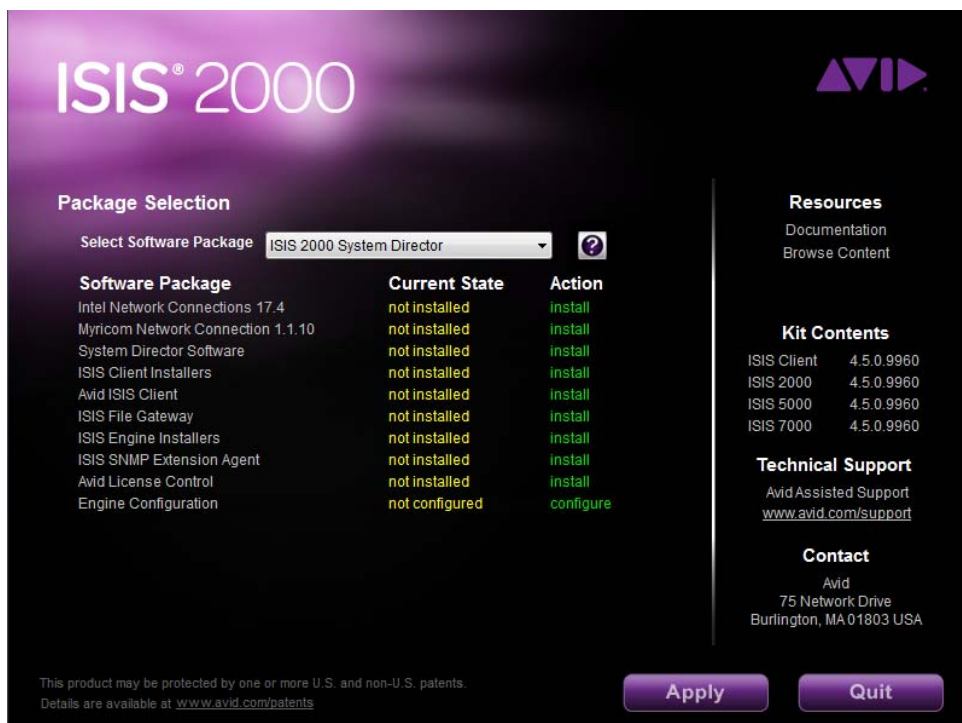

 *Avid highly recommends that you click the Documentation link. This displays the ReadMe file that provides the latest information regarding the Avid ISIS 2000 system. You must have Adobe Reader installed to view the PDF.*

6. Select ISIS 2000 System Director from the “Select Software Package” menu.

When setting up the ISIS 2000 Engine for the first time, the RAID set configuration is performed when you Upgrade the Storage Managers in the Management Console. This function is not performed if your RAID set has already been configured. Typically this is the case when upgrading the software version.

 *When you initially install the Avid ISIS 2000 system and initialize the RAID set, it will take approximately 72 hours regardless if you have an ISIS 2000-240 TB or ISIS 2000-120 TB Engine configuration. During this initialization, the system is functional and able to support a limited amount of client traffic. Client traffic can significantly increase the initialization time. For more information about the initialization time, see the Avid ISIS Performance Guides.*

The following table describes the installer options and their functions.

Installer Dialog Box

Selection	Function
Package Selection	<p>Select the ISIS software kit from the “Select Software Package” menu.</p> <ul style="list-style-type: none"> • ISIS 2000 System Director — Selects the ISIS 2000 software kit. Select this menu item to install the Avid ISIS 2000 software on the System Director. • ISIS 5500 5000 Engine — Select this menu item if you are loading the software on optional storage enclosers. Once you have the System Director software on one of your enclosures, all of the additional enclosures are optional. These enclosures are referred to as Engines. Optional enclosures include just the Engine Software. • ISIS 5500 5000 Engine/ System Director — Select this menu item if you have one enclosure or have multiple enclosures but want this enclosure to be the System Director which includes the software that runs the Management Console and tracks the metadata stored in all the media drives. • ISIS 7500 7000 System Director — Selects the ISIS 7500 7000 software kit. Select this menu item to install the Avid ISIS 7500 7000 software on the System Director. This software cannot be installed on the same server as the File Gateway’s software. • System Director Client Installers — Select this menu item to install the Avid ISIS client installer software for the ISIS clients. • ISIS Windows Client — Select this menu item to install the Avid ISIS client software on Windows clients. This installer detects the Windows client’s operating system, and installs the appropriate client software. If a previous ISIS client software is installed, the old version is uninstalled and the new version is installed.



Installer Dialog Box (Continued)

Selection	Function
Software Installation System Director Software	<ul style="list-style-type: none"> • ISIS File Gateway — Select this menu item to install the Avid ISIS File Gateway software on a standalone File Gateway server. This software is included with the ISIS 2000 System Director software and cannot be installed on the same server as the ISIS 7500 7000 or ISIS 5500 5000 System Directors. If setting up the ISIS File Gateway, see the <i>Avid ISIS File Gateway Setup and User's Guide</i>. • Remove ISIS Software — Select this menu item to uninstall the Avid ISIS software. You do not need to run the uninstaller if upgrading your ISIS. The ISIS installers automatically detect your ISIS software and uninstalls the necessary components before installing the selected ISIS software. Use this menu selection if an attempt was made to install the ISIS software without using installer splash screen. Components that are left behind are detected and uninstalled properly. You can also use this menu selection if planning to remove all the ISIS software without installing other ISIS software. This one selection saves you from selecting several software components in the Windows Control panel.
	<p>Select “ISIS 2000 System Director” from the menu to install the ISIS 2000 System Director software which runs the Management Console and tracks the metadata stored in all the media drives.</p> <ul style="list-style-type: none"> • Intel Network Connections — Installs the Intel driver supported in the release. This driver is installed on the System Director and Engines. • Myricom Network Connection — Installs the Myricom driver supported in the release. This driver is installed on the System Director and Engines. • System Director Software — Installs the System Director software used to run the media drives and creates the file system for the media drives. It also provides the ISIS Management Console and error logging. The installer detects the operating system (Windows 64-bit) and installs the appropriate software and creates the file system used by the Engines; it also provides the ISIS Management Console and error logging.

Installer Dialog Box (Continued)

Selection	Function
	<ul style="list-style-type: none"> <li data-bbox="515 291 1293 413">• ISIS Client Installers — Installs the “client installers” on the System Director. Clients can then install the latest software on the clients from the System Director Management Console window. These installers are accessed when you click the Installers icon in the Management Console. <li data-bbox="515 430 1293 482">• Avid ISIS Client — Installs the Avid ISIS client software required on the ISIS 2000 System Director for the File Gateway services. <li data-bbox="515 499 1293 656">• ISIS File Gateway — Installs the Avid ISIS File Gateway software. The File Gateway software enables network users to access Avid ISIS Workspaces in a non-realtime scenario. Depending on the access permission, network users can read, write, and delete files on Workspaces without using up ISIS client licences. <li data-bbox="515 673 1293 829">• ISIS Engine Installers — Installs the code used to upgrade the ISIS 2000 Storage Manager in the Engine. Storage Manager is then upgraded using the System Director Management Console. This code is applied when you click the Upgrade button in the Management Console > Storage Manager page. <li data-bbox="515 847 1293 1025">• ISIS SNMP Extension Agent — Installs software to support Simple Network Management Protocol (SNMP). It is used with network management to monitor network-attached devices for conditions that warrant administrative attention. These SNMP monitoring agents are used with an OpenNMS user interface to support the Avid System Monitor.
	<p data-bbox="554 1043 1282 1164">Avid System Monitor is an option for ISIS 2000 systems covered by the “Avid Uptime Support” contract option. The software required for the monitoring solution is provided as part of the Avid PS installation engagement.</p>
	<ul style="list-style-type: none"> <li data-bbox="515 1182 1293 1369">• Avid License Control — Installs the Avid License Control tool software on the System Director. The Avid ISIS software can be installed without licensing the software but you cannot make an Active File System or connect any clients until you run the Avid License Control tool and activate the ISIS software. For instructions see “Avid ISIS Software Licensing” on page 104.

Installer Dialog Box (Continued)

Selection	Function
	<ul style="list-style-type: none"> Engine Configuration — Configures the Intel and Myricom driver settings required for the release. There is no need to open network Properties and make changes to the setting. This configuration is performed on the System Director and Engines.
	 <i>If you have made a change to the Intel or Myricom settings and want to set them back to the Avid defaults, re-run the ISIS software installer (autorun.exe) and the Avid network settings are re-applied.</i>
Resources	
Documentation	<p>This is a link that brings you directly to the AvidISISDocumentation folder on the Avid ISIS installer kit. This folder can be wherever the installer files have been saved. This folder has all of the Guides that are included with the release.</p> <p>Avid recommends that you read all the information in the ReadMe file thoroughly before installing software or attempting to use the Avid ISIS system. This ReadMe provides information that is not in the other Avid ISIS documentation.</p>
	 <i>Search the Avid Knowledge Base for the most up-to-date ReadMe file, which contains the latest information that might have become available after the documentation was published. To view the online version, visit the Knowledge Base at www.avid.com/readme.</i>
	<p>The document provides hardware and software requirements, a limitations and known issues, and other important information. You can access the documentation in the top-level AvidISISDocumentation folder on the Avid ISIS installer kit.</p>
Browse Content	<p>This is a link that brings you directly to the Avid ISIS installer kit. From here you can access all the files included in the kit. This folder can be wherever the installer files have been saved.</p>
Kit Contents	<p>Displays the version numbers of the Avid ISIS software included in this kit.</p>
Technical Support	<p>This link brings you to the Avid support web site (www.avid.com). If you do not have internet access on the computer running this software installation, Page not found is displayed.</p>
Contact	<p>Displays the Avid corporate address.</p>

- Click Apply.
- Follow the screen prompts accepting the defaults and License agreement.



When uninstalling or upgrading the ISIS 2000 software, you might get prompted to confirm the removal of the File Gateway software. Type Y to confirm the removal.

9. Once the installation is complete, click Finish.
10. After the ISIS 2000 software is installed, you must restart the System Director.

Separate VLAN on Switch for ISIS 2000

ISIS 2000 systems typically are integrated with ISIS 7500 | 7000 or ISIS 5500 | 5000 environments. Each ISIS system should be in a different broadcast domain /VLAN. The ISIS 2000 System Director and ISIS 2000 Engine are connected to ISIS 7500 | 7000 or ISIS 5500 | 5000 switches that have been configured with a separate VLAN for the ISIS 2000 components. See your site network administrator for assistance with configuring the separate VLAN on your switch

Activating the License Key

You need to activate your Avid ISIS software before you can make an Active File System. After installing your software, see [“Avid ISIS Software Licensing” on page 104](#)



Previous versions of Avid ISIS software use an application key plugged into the System Director to allow clients to connected to the ISIS infrastructure. New ISIS systems ship with software licensing that is activated online. Software licensing is only required with new ISIS installations. Clients cannot access the Avid ISIS software until the license key has been activated.

If configuring a Dual System Director for metadata redundancy, you will need a second application key with the second System Director, For more information, see [“Configuring System Director Resiliency” on page 91](#).

Creating an Active File System on the System Director

After the software installation and the System Director has restarted, new installations must be initialized by creating an Active File System on the System Director.

To create an Active File System:



1. In the ISIS Launch Pad, click ISIS Control Panel icon or Start > Programs > Avid > ISIS System Director and select Control Panel.

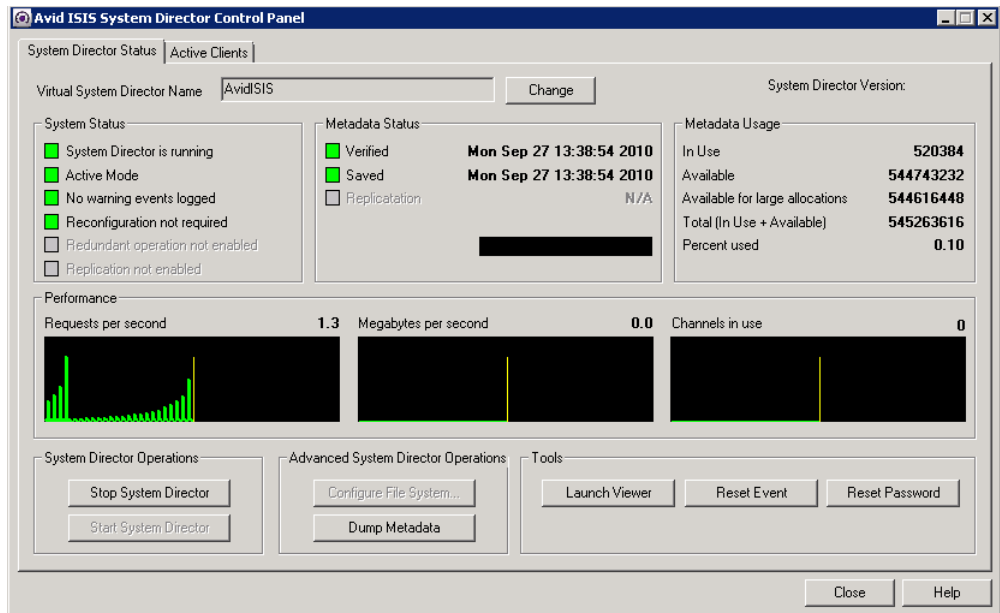

2. Click Stop System Director.

The Configure File System button becomes active.

3. Click Configure File System.

The File System Configuration dialog box opens.

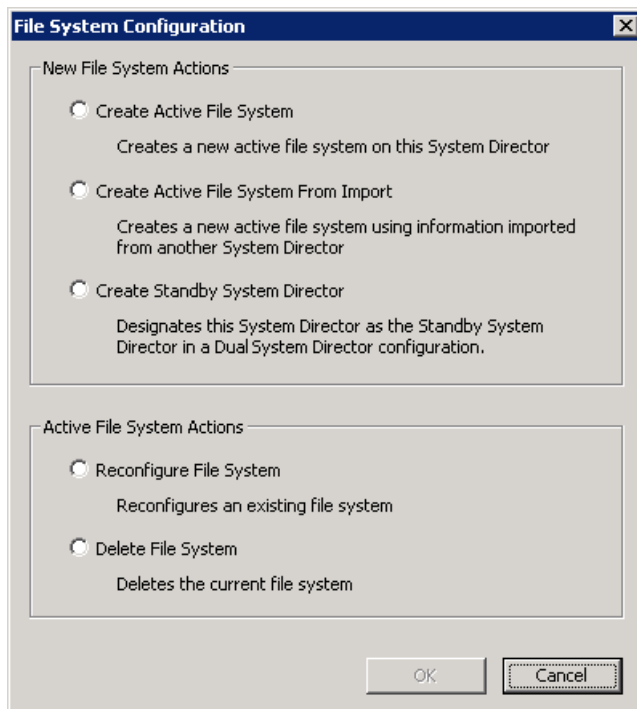

When you Create Active File System, this action results in the loss of all media assets on the system. This is a non-recoverable action and extreme caution should be exercised when this command is invoked.

4. (First System Director) Select Create Active File System and click OK.

The Avid ISIS System Director service automatically starts when complete. In the System Director Control Panel, the “System Director is running” display turns green.

5. (Option) If creating a Standby System Director in an metadata redundancy configuration, see [“Configuring System Director Resiliency” on page 91](#).

Installing Software on the Engine

After you have loaded new software on the System Director you need to upgrade the software on the Engine. You can use Management Console from anywhere to perform the following functions, but you usually do it from the System Director:

- Upgrade the Storage Manager with the proper/latest software
- Create Workspaces

To load the Engine software:

1. Go to [http://IP address of System Director \(or virtual name\)](http://IP address of System Director (or virtual name)).
2. Log into the System Director.



The default Administrator password is blank.

The ISIS Management Console opens.



3. Click Storage Manager.
4. Select the Storage Manager in the list.

Home Storage Managers		Related Links Storage Elements				
Name	Host Name	Status Time	Status	Uptime	State	Type
A-NL5	A-NL5	06/22/2013 13:22:36		0 days 05:08:25	Unbound	Nearli

- Click Upgrade.

The Upgrade Storage Managers window opens.

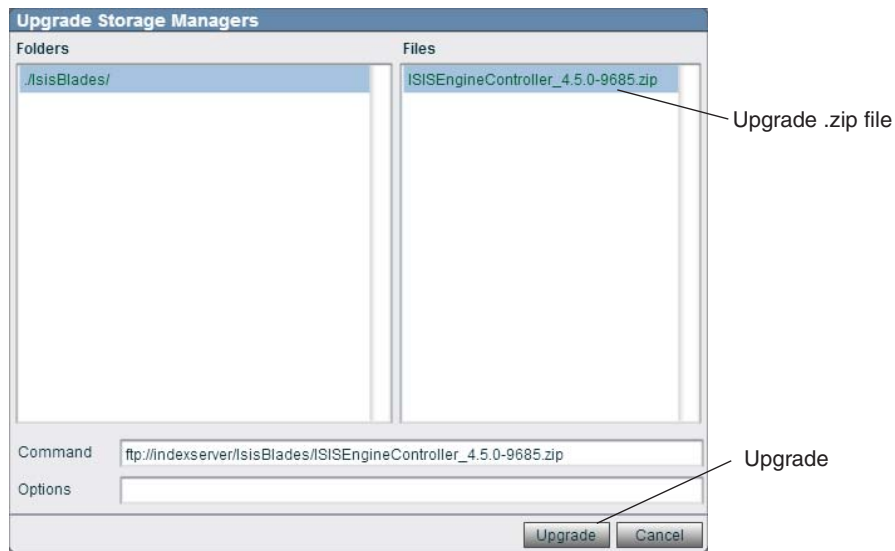

- Select the .zip file, and click Upgrade.

The Storage Manager installation takes approximately 10 minutes.



Once the Storage Manager upgrade has completed, the software automatically starts building the RAID sets in the ISIS 2000 Engines. Due to the size and number of drives in the Engine, the RAID configuration takes a couple days to complete. Clients can use the ISIS 2000 system during this time although, the more client activity on the Engine, the longer it takes to finish the RAID configuration.

- Select a Storage Manager from the list and click Details.

The screenshot shows the 'Storage Managers' web interface. At the top, there are navigation links: Home, Storage Managers, Related Links, Storage Elements, Storage Groups, Help, and Logout. Below the navigation bar is a toolbar with buttons: Refresh, Bind, Unbind, Upgrade, Issue Command, Force Remove, and Details. The main area is divided into two panes. The left pane contains a table with columns: Name, Host Name, Status Time, Status, and Uptime. The right pane is titled 'Details' and shows information for a selected storage element.

Name	Host Name	Status Time	Status	Uptime
A-NL5	A-NL5	06/22/2013 13:22:36		0 days

The Details pane shows the following information for the selected element:

- Name: A-NL1
- Host Name: A-NL1
- Status Time: 06/13/2013 06:17:13
- Status: unbound
- Uptime:
- State: Unbound
- Type: Nearline Engine
- Capacity: 29,801.06 GB
- Usable: 29,801.06 GB
- Spare: 0
- Active: 1
- Other: 0
- Version: 4.5.0.9685
- Engine Serial: SHX0964999G06G5

Below the details pane, there are sections for 'Storage Elements' and 'IP Addresses'. The 'Storage Elements' section shows a table with columns: Name, Storage Manager, Hostname, and Status. The 'IP Addresses' section shows a table with columns: IP Address.

Name	Storage Manager	Hostname	Status
SE000	SM000	A51-NL7-SBB	04/08/2

IP Address
10.105.55.198

At the bottom of the details pane, there is an 'Info' button and a 'Close' button.

The Status for the upgrade is shown in the Details pane at the right of the window. Click the Refresh button whenever you want the updated upgrade Status. When the Status is empty, the upgrade is complete.

8. (ISIS 2000-240) Double-click the IP address of the original Storage Element in the Details pane to open ISIS 2000 Storage Manager Agent Web page.
9. (ISIS 2000-240) You are asked for the password. Type **se-admin**.
10. (ISIS 2000-240) Click Network in the left pane of the System tab.
The ISIS 2000 Storage Manager Agent page appears.

Avid ISIS Storage Manager
192.168.0.10 / ISIS2000_Eng1

System | Statistics | Tools | Logging | Advanced

System
Status
Configuration
 ▶ Network
 Time
Administration
Versioning
Show Version Information

Basic Network Configuration

Hostname:

Default Gateway:

Data Interfaces

	Address	Netmask	Description
gx0	<input type="text" value="192.168.0.02"/>	<input type="text" value="255.255.255.224"/>	10 Gbps Left
gx0:1	<input type="text"/>	<input type="text"/>	10 Gbps Left

Management Interfaces

	Address	Netmask	Description
ge0	192.168.0.10	255.255.255.0	1 Gbps Left

11. (ISIS 2000-240) Enter an IP address in the gx0:1 and Netmask text boxes in the Data Interfaces section.

The ISIS v4.5 release provides dual IP addresses for the Engine Controller in the ISIS 2000 Engine. This new IP Address must be in the same subnet as the original IP address.



A second physical cable is not needed, both IP address are handled through the existing 10 Gb connection between Engine Controller and the switch.

12. (ISIS 2000-240) Click Submit.
- A dialog box appears warning you a Engine reboot is required; click the Reboot button.
 - A second dialog box appears, type **se-admin.** in the password box and click Reboot.
13. (ISIS 2000-240) When the Engine has restarted, open the Storage Manager page in the Management Console.



You will notice there are now two Storage Managers in the Storage Managers page.

Binding the Storage Managers

After you have created an Active File System you need to bind the Storage Managers using the Management Console. If you have more than one Engine in your ISIS 2000 configuration, they appear listed in the Storage Manager page. One or multiple Storage Managers can be bound.

 *This procedure assumes you are creating an Active File System on a new unused Engine. If you attempt to create a File System on an Engine that has been used before, your Storage Managers might enter an Orphaned state. To remove an Orphaned state, search the Avid ISIS Administration Guide for instructions on “Removing Orphaned Storage Managers.”*

To bind the Storage Managers:

1. Type `http://IP address of System Director` in your browser.



If already logged into the System Director, click the Management Console icon in the Launch Pad.

2. Log into the System Director and access the Management Console.



The default Management Console Administrator password is blank (no password).

3. Click the Storage Managers icon or click the unbound Status message in the System Status console.



If you have an ISIS 2000-120 configuration, one Storage Manager is displayed. Two Storage Managers are displayed for each ISIS 2000-240 Engine.

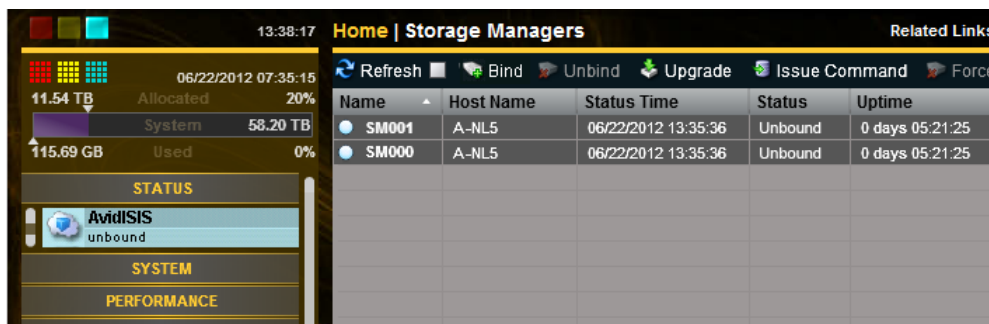

Name	Host Name	Status Time	Status	Uptime
SM001	A-NL5	06/22/2012 13:35:36	Unbound	0 days 05:21:25
SM000	A-NL5	06/22/2012 13:35:36	Unbound	0 days 05:21:25

4. Select the Storage Managers listed in the Storage Managers page.
Multiple Storage Managers can be selected and bound.
5. Click Bind.
6. Click Yes to confirm the request.
7. Click Refresh to see the status circle next to the *Name* change to green when complete.

Creating a Storage Group

You can only create a Storage Group after you have bound the Storage Managers see “[Binding the Storage Managers](#)” on page 78. A Storage Group requires at least one Storage Manager. The ISIS 2000-120 Engine can be configured for one Storage Group, the ISIS 2000-240 Engine can be configured for one or two Storage Groups. If you have multiple Engines, all the Storage Managers can be configured as single Storage Group.

To create a Storage Group, click the Storage Group icon in the Management Console. See the *Avid ISIS Administration Guide* for additional information about creating a Storage Group.

Creating Workspaces

Workspaces are locations to store and segregate data. They appear as network drives to the clients. You can allow users to access some or all of the workspaces, and assign permissions for how each user can access the data in a workspace.

Create Workspaces after you have created your Storage Group. To create Workspaces, click Workspaces icon in the Management Console. See the *Avid ISIS Administration Guide* for information on creating Workspaces.

Creating User Accounts

User accounts allow individual users, or groups of users, access to the workspaces. These accounts allow users to mount or map Avid ISIS workspaces on their workstations.

To add users, click the User icon in the Management Console. See the *Avid ISIS Administration Guide* for additional information about creating new users.

Turning Off the CIFS Service With a 1 Gb Connected System Director

If you are using a 1 Gb connection between the ISIS 2000 System Director and the switch, you must turn off the CIFS service. By default ISIS software starts the CIFS service using the 10 Gb port.



Only System Directors with a 10 Gb connection to the switch support CIFS clients. If you reconfigure your System Director to use a 10 Gb connection between the System Director and the Switch, you must reset this service to run automatically.



If you upgrade or reload the ISIS software, this default CIFS setting is reset to automatically start. You need to disable the setting each time the software is installed on the ISIS System Director.

To Start and Stop your CIFS service:

1. Right-click on the *My Computer* icon and select Manage.
The Server Manager window opens.
2. Expand the Configuration menu in the left pane and select Services.
3. Right-click AvidISISFileGateway in the right pane and select Properties.

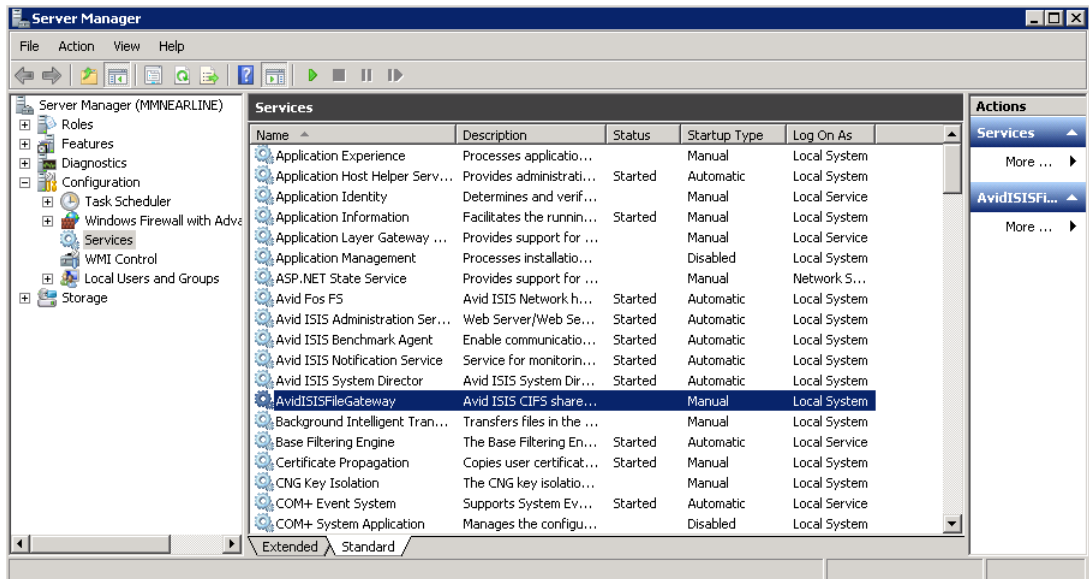

4. Select Disabled from the “Startup type” menu.

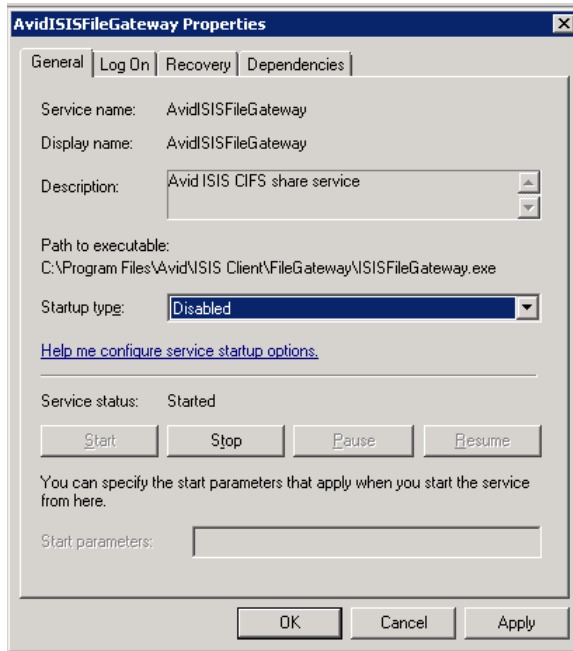

5. Click Apply, and then click OK.
6. Close the Server Manager window.

Checking the Status of the System Director

After you have installed the System Director software, an Avid ISIS Launch Pad is displayed on the System Director Desktop.

To open and close the Launch Pad:

1. If the ISIS Launch Pad is not displayed on the Avid ISIS System Director Desktop, click the ISIS Launch Pad icon in the Taskbar's System Tray to display or hide the Launch Pad.



You can also open other ISIS tools by clicking the icons in the Launch Pad.

The ISIS Launch Pad is displayed.



2. Start or stop the System Director by clicking one of the following icons in the ISIS Launch Pad.



- ▶ Click the blue square icon to stop the System Director.
- ▶ Click the blue triangle icon to start the System Director.

Loading Client Software

Avid ISIS client software is supported on Windows, Macintosh and Linux clients. For information on using your client software see the *Avid ISIS Client Guide*. You can load the Client software in the following ways:



If upgrading the Client Manager software using the file in the software kit or Installer page of the Management Console, you must first uninstall the Client Manager software using the Windows Control Panel before installing a new version of Client Manager. Macintosh clients can just install the new client software over the old version and no reboots are required.

- You can use the a Browser to reach the ISIS Management Console and load it from the System Director.



If the client does not have Flash installed, you won't be able to access the Management Console. A prompt is displayed with a link to the Flash installer.

- Download the client installers from the Management Console and copy the software to a USB flash drive.
- You can store the client software somewhere on the network and allow everyone who needs the software to gain access to it and load it.
- You can load the ISIS software kit on the Windows client and double-click the `autorun.exe` file. Select the "ISIS Windows Client" installer from the Select Software Package menu.



The installer automatically uninstalls an earlier version of software.

To access the client software using a browser:

1. Start your browser application.
2. Run your Windows Update and accept all "High-priority Updates."
3. Type `http://IP address of System Director` in your browser.



If your Avid ISIS network includes a Domain Name System (DNS), you can type the System Director's name in the browser (default Virtual name is AvidISIS).

The ISIS Management Console opens.

4. Type your ISIS user name and password.
5. Click the Installers icon.

An Installer Downloads screen opens.

IsisBlades
ISISStorageBlade_4.6.0_12075.tgz
ISISSwitchBlade_4.6.0_12075.tgz
ISISClient
AvidISISClient_AirSpeed_4.6.0_12075.iso
AvidISISClient_e16.x86_64_4.6.0_12075.bin
AvidISISClient_MacOSX_4.6.0_12075.dmg
AvidISISClient_Win32_4.6.0_12075.msi
AvidISISClient_Win64_4.6.0_12075.msi
AvidUnityISISClient_ILRE_4.6.0.20.tgz.des
ISISTools
<u>LDAP Sync Tool</u>
LDAPSyncTool_MacOSX_4.6.0_12155.dmg
LDAPSyncTool_Win32_4.6.0_12075.exe
LDAPSyncTool_Win64_4.6.0_12075.exe
<u>Monitoring Tool</u>
MonitoringTool_MacOSX_4.6.0_12155.dmg
MonitoringTool_Win32_4.6.0_12075.exe
MonitoringTool_Win64_4.6.0_12075.exe
<u>Toolbox</u>
Toolbox_MacOSX_4.6.0_12155.dmg
Toolbox_Win32_4.6.0_12075.exe
Toolbox_Win64_4.6.0_12075.exe
ThirdParty
flashplayer_11_2_linux_i386.tar.gz
flashplayer_11_2_linux_plugin.i386.rpm
flashplayer_11_2_linux_plugin.x86_64.rpm
flashplayer_11_2_linux_x86_64.tar.gz
flashplayer_11_6_osx.dmg

6. Click the appropriate client installer.

The installer might ask if you want to save or run the installation software; either is acceptable.



If you were able to access the Management Console it means that your client already has Flash installed.

To install your Avid ISIS Windows client software from the software kit:

1. Log into your Windows client system as a user with Administrative privileges.
2. Load the new software kit on you Windows client system.
3. Double-click the `Autorun.exe` file in the software kit.

The installer detects the existing version of the installed client software (if any) and displays the components that need to be upgraded in the splash screen.

4. Select the “ISIS Windows Client” installer from the Select Software Package menu.
5. Click Apply.



The installer automatically uninstalls an earlier version of software without having to use the Windows Control Panel and installs the new software with a single click.

6. Install the client software following the on-screen prompts. Accept the defaults when uncertain of any choices.
7. Restart the client when prompted.

The client software starts automatically when restarted.

8. You might need to update the Intel Pro driver on your client system, see *Avid ISIS ReadMe*.
9. Repeat this procedure on each Avid ISIS Windows client.



You can manually copy the client installers to a USB flash drive. The installers are in the Avid ISIS software kit located on [drive]:\AvidISISClientInstallers. You can also log into the Management Console and access the Installers link and download the appropriate client installer.

When manually installing the ISIS client software, you need to uninstall the previous version of the ISIS client software using the Windows Control Panel, restart, install ISIS client, and restart the Windows client.

To install your Avid ISIS Macintosh client software:

1. Copy and save the new AvidISISClient_MacOSX_x.x.x.dmg file from the:
 - ▶ \AvidISISClientInstallers folder in software kit to your Macintosh client system.
 - ▶ Management Console > Installer page to your Macintosh client system.
 2. Double-click the AvidISISClient_MacOSX_x.x.x.dmg file.
 3. Double-click the AvidISISClient.mpkg file to run the installer.
- Follow the on-screen instructions.



The installer replaces earlier versions of the software (if any).

4. Repeat this procedure on each Avid ISIS Macintosh client.



You can manually copy the client installers to a USB flash drive.



The Macintosh client software installs an uninstaller application located at Applications > Avid_Uninstallers > AvidISIS. Use this application only when you want all Avid client files removed; including Client Manager preferences.

To install ISIS Linux client software:

1. Copy and save the new `AvidISISClient_e16.x86_x.x.x.bin` file from the:
 - ▶ `\AvidISISClientInstallers` folder in software kit to the user's home directory of your Linux client system.
 - ▶ Management Console > Installer page to the user's home directory of your Linux client system.
2. Open the Terminal application: Application > System Tools > Terminal on your Linux client.



When using the Terminal program, file names and paths are case sensitive.

3. Type `cd [user's home directory]` and press **Enter**.
4. Do one of the following.
 - ▶ If you are not the root user, type `sudo ./AvidISISClient_e16.x86_x.x.x.bin` and press **Enter**. You will need to enter your password.
 - ▶ If you are the root user, type `./AvidISISClient_e16.x86_x.x.x.bin` and press **Enter**.



The installer replaces earlier versions of the software (if any).



You can manually copy the client installers to a USB flash drive.

5. Restart the Linux client.

Configuring Client Software

To mount workspaces on the client do the following:

1. Load the client software as explained in “Loading Client Software” on page 82.
2. Do one of the following:
 - ▶ (Windows) If the Client Manager icon is not available in the Windows taskbar, select Start > Programs > Avid > ISIS Client > ISISClientManager.
 - ▶ (Windows) Click the Client Manager icon in the Windows taskbar.
 - ▶ (Windows) Right-click the Client Manager icon and select Avid ISIS Client Manager.



- ▶ (Macintosh) If the Client Manager alias icon is not available, select Go > Applications, and then double-click the AvidISIS folder. In this folder, double-click the ISISClientManager.app file.

The ISIS Client Manager opens.

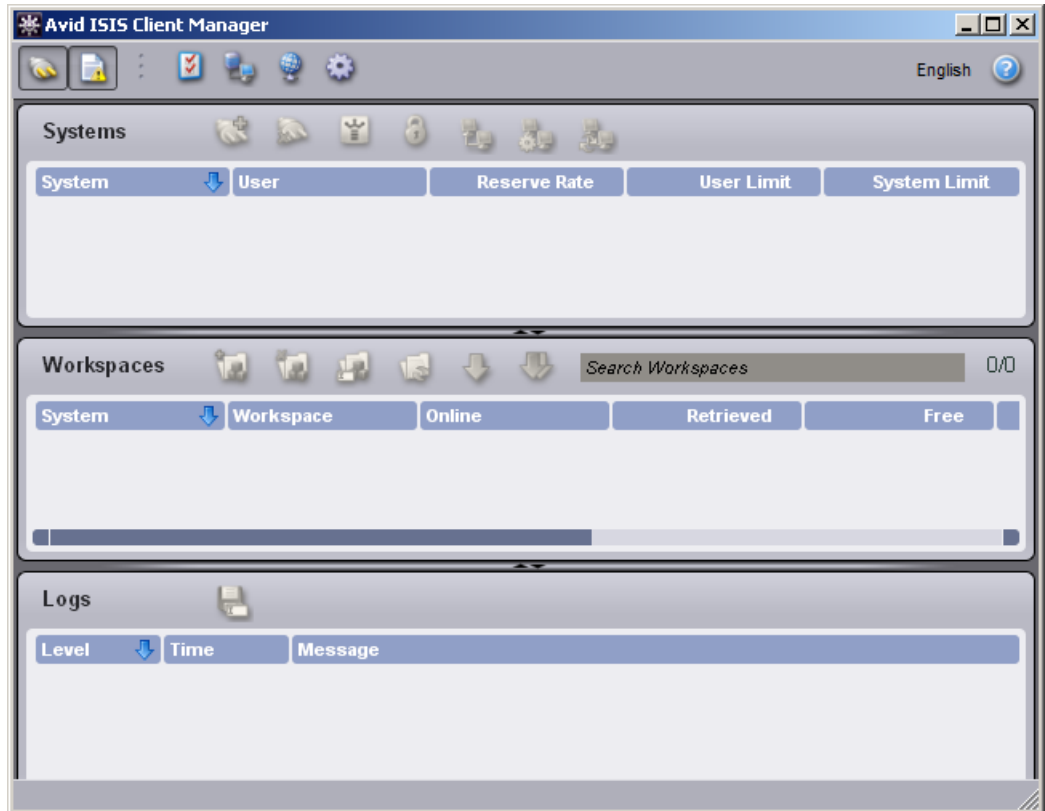

3. The first time you login, you might need to select a Remote Host (Avid ISIS system). For information about adding a remote host, see the *Avid ISIS Client Guide*.

4. Select the ISIS system in the Systems panel.



5. Click the Connect button in the Systems panel.

6. Login using the Username and Password assigned to you by the Avid ISIS administrator. Do one of the following:

- ▶ (Windows) Type your account name in the Username text box, and type your password in the Password text box.

- ▶ (Windows) If your ISIS system is configured to use the Windows user name and password for your local system, select OS Login. By default, the Username and Password text boxes are inactive when you select this option.

(Optional — Windows only) If you used the OS Login option, and you want to connect to the network automatically every time you start your system, select the Auto-Connect checkbox.

- ▶ (Macintosh) Type your Avid ISIS account name in the Username text box, and type your password in the Password text box.
- ▶ (Linux) Type your Avid ISIS account name in the Username text box, and type your password in the Password text box.

When the connection is successful:

- Workspaces you have been given access to are listed in the Workspaces list.
- The Client Manager buttons become active.

Adding a Remote Host for Zone 3 and 4 Clients

If your client is not on the same subnet as the ISIS shared storage network, you need to add the name of your System Director in order for the Client Manager to connect to it. If your system does not use a DNS server to configure your network connections, you can also type the IP addresses of the remote host, but you cannot use the virtual server name or virtual IP addresses.



Clients on the same subnet as the ISIS System Director, automatically have the System Director listed in the toolbar of the Client Manager window.



You need to add the name of all Active and Standby System Directors in your network. For System Directors that are dually-connected to the network, you need to add both subnet addresses.

To add a remote host:

1. Open the Client Manager (see “Configuring Client Software” on page 86).

The Client Manager opens.



2. Click the Remote Host Settings button.

The Remote Hosts dialog box opens.

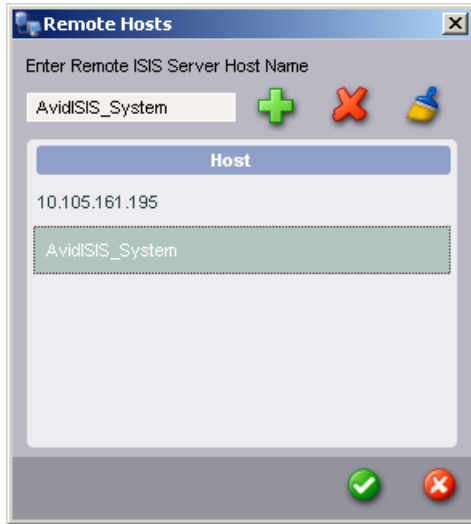

3. In the text box, type the actual server name or IP address of the Avid ISIS System Director to which you want to connect.

You cannot use the virtual server name or the virtual IP address of the remote host.



4. Click the Add button.

The Input dialog box opens.

5. In a Dual System Director configuration, you need to type the actual server name or IP address of the Standby System Director.

You cannot use the virtual server name or the virtual IP address of the Standby System Director.



6. Click the Add button.



The Client Manager user interface could take up to 30 seconds to display changes made in the Remote Host Settings.

7. Click the green check mark to apply the settings or the red X to close the dialog box without any changes.

Avid Interplay Authentication

Avid Interplay Authentication requires the Avid ISIS System Director to use a virtual name. The System Director's virtual name must not match the actual host name and must be entered in the General Configuration Options dialog box even if your Avid ISIS system configuration only has one System Director. For instructions on adding the virtual name, search the *Avid ISIS Administration Guide* for General Configuration Options.

4 Configuring System Director Resiliency

This chapter explains how to enable the software for a failover using two System Directors.



The Active and the Standby System Directors must be using the same image on the server, you cannot mix images.

System Director Failover

When using two System Directors, one is referred to as Active System Director and the other one is the Standby System Director. The File System on the Standby System Director is kept up-to-date with the Active System Director. If the Active System Director fails, a failover function switches to the Standby System Director. There might be a brief interruption in client connectivity but all clients re-connect automatically when the Standby System Director becomes active. In an attempt to keep the procedure easy to use, we use the following nomenclature:

- When adding a new System Director to an existing Avid ISIS system or creating a failover system configuration, the original System Director is called the existing System Director and the new System Director is called new.
- When installing two new System Directors to create a failover system configuration, one System Director is called Active and the other Standby.

The System Director crossover cables must be connected to the 1 Gb on-board 82567LM-4 and 82574L ports. These two 1 Gb ports are the left two 1 Gb System Director ports (when facing the rear). The 1 Gb Intel Pro 1000 ports on the right side are not used when configuring dual ISIS 2000 System Directors. Connect the two System Directors under the following conditions:

- After you have physically configured the system and loaded the Avid ISIS software on both System Directors.
- When the System Director service is stopped on both systems.

Cabling Dual System Directors

To connect dual System Directors:

1. Connect the two System Directors using a 1 Gb cable (straight or crossover) as shown in the following figure.

Connect the two bottom-left ports of the System Directors with one Ethernet cable and connect the two top-left ports of the System Directors with a second Ethernet cable.

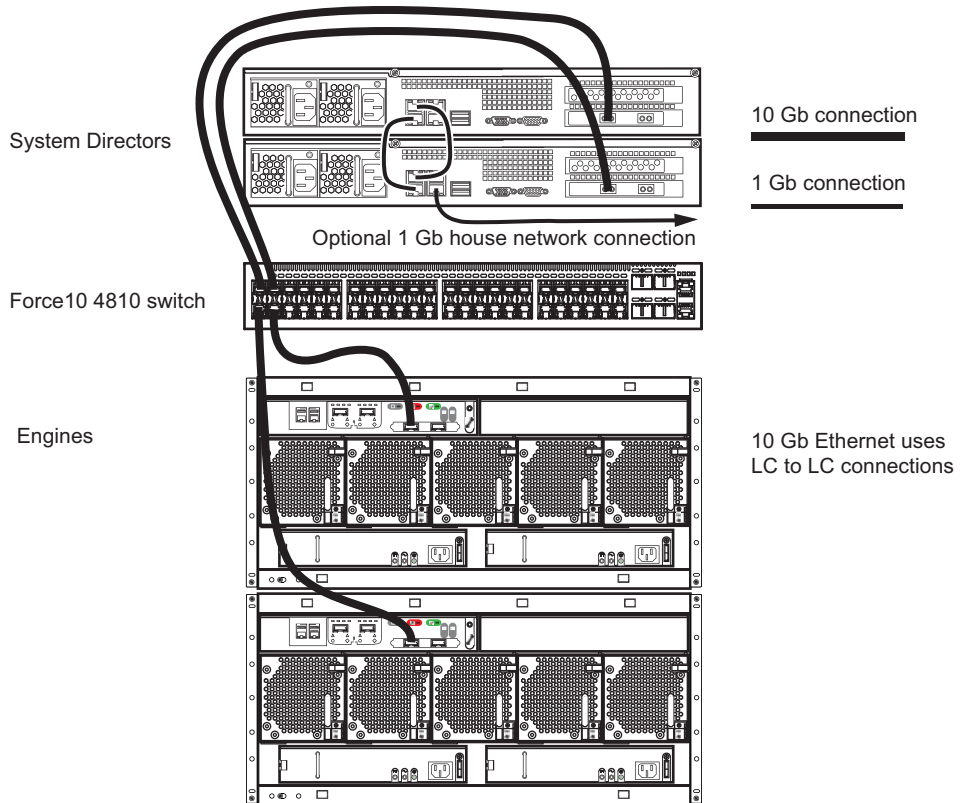

2. Enable the software on both systems, see [“Configure a Failover Connection”](#) on page 93.



The configuration information for the notification service (SMTP information, contacts, and filters) is stored in the registry on the System Director. This information is not currently replicated to the failover System Director and must be entered manually on both System Directors. For information on setting up the notification service, see [Setting up Error Notification in the Avid ISIS Administration Guide](#).

Setting IP Addresses for Crossover Link

Avid recommends the System Director IP addresses for failover configurations that are listed below. If you use different addresses, be sure to note them and have them available before proceeding. You set the IP addresses in the Network Connections dialog box, which you access from the Windows Control Panel. For information on setting Windows IP addresses, see the documentation that came with your operating system.

To set IP addresses:

1. Go to Start > Control Panel > Network Connections for each System Director.
2. Set the Existing System Director to the following TCP/IP addresses for ports 1 and 2:
 - Onboard Ethernet port 1 (ETH1) - 192.168.1.1 netmask 255.255.255.0
 - Onboard Ethernet port 2 (ETH2) - 192.168.2.1 netmask 255.255.255.0
3. Set the New System Director to the following TCP/IP addresses for ports 1 and 2:
 - Onboard Ethernet port 1 (ETH1) - 192.168.1.2 netmask 255.255.255.0
 - Onboard Ethernet port 2 (ETH2) - 192.168.2.2 netmask 255.255.255.0

Configure a Failover Connection

Setting up the ISIS system for a System Director failover is done on two System Directors. The first System Director is referred to as the Active System Director and the second System Director is referred to as the Standby System Director.



Make sure all clients are notified that you are stopping the System Director.

To set up a failover connection on the Active System Director:

1. Load the ISIS software on the Active System Director as described in [“Loading the Software”](#) on page 65.



2. In the ISIS Launch Pad, click ISIS Control Panel icon or Start > Programs > Avid > ISIS System Director and select Control Panel.

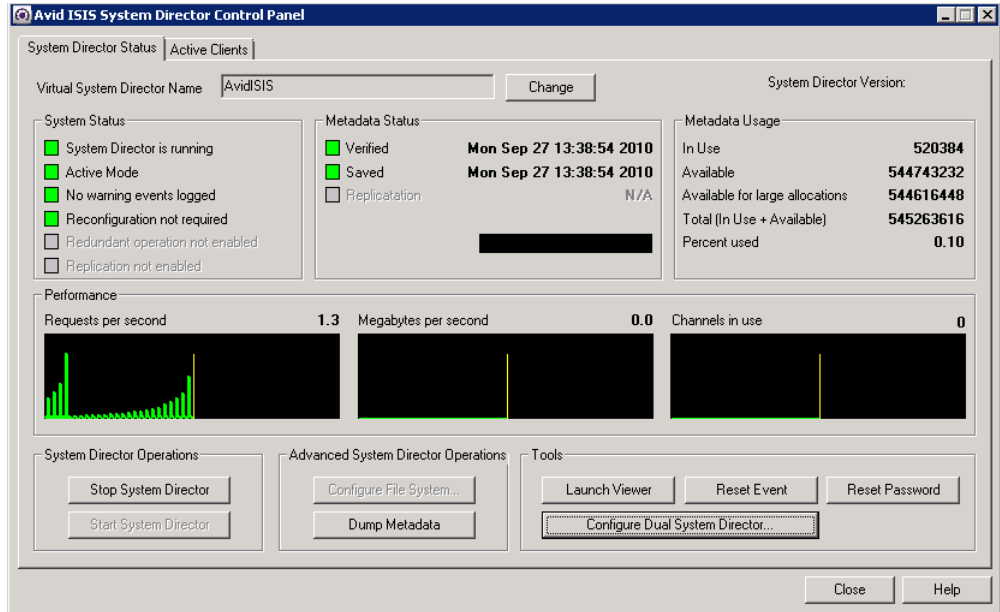

3. Click Stop System Director.

The Configure File System button becomes active.

4. Click the Change button beside the Virtual System Director Name and type a name in the Virtual System Director Name text box and click OK.



The same virtual name must be assigned to both System Directors.

5. Click Configure File System.

The File System Configuration dialog box opens.

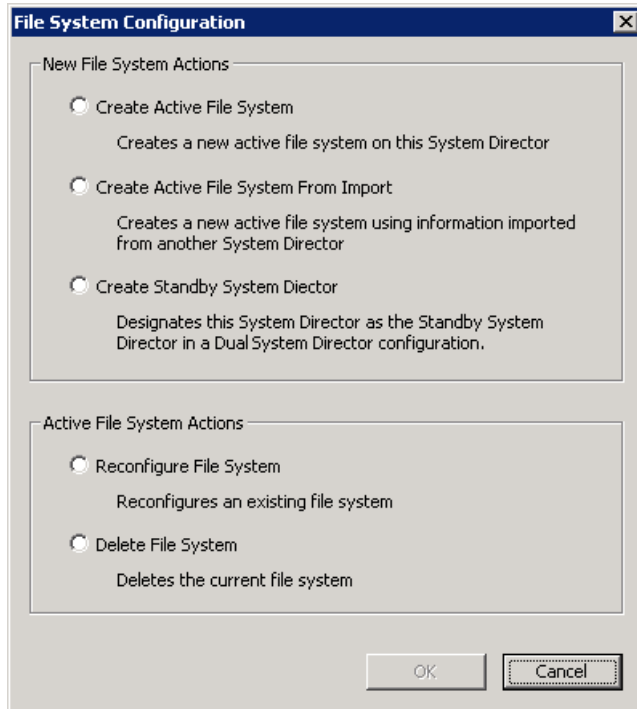

6. (First new System Director) Select Create Active File System and click OK.



If you already have a running System Director do not create a new file system and skip this step. If you create a new file system on a System Director that already has a file system all of your existing data will be lost.

The Avid ISIS System Director service automatically starts when complete. In the System Director Control Panel, the “System Director is running” display turns green.

7. Click Stop System Director.

The Configure Dual System Director button becomes active.

8. Click Configure Dual System Director.

The Dual System Director Configuration dialog box opens.

Enable Dual System Director Configuration

Dual System Director Configuration

Enable Dual System Director Configuration Local Machine Name: ISISUI1

Virtual Address

Virtual Address: 192 . 168 . 10 . 253 Local interface to which the address is assigned: 192 . 168 . 10 . 100

Virtual Address 2

Virtual Address: 192 . 168 . 20 . 253 Local interface to which the address is assigned: 192 . 168 . 20 . 100

Local Machine Routing Parameters

Monitor Port: 5000

First path: 192 . 168 . 1 . 1

Second path: 192 . 168 . 2 . 1

Remote Machine Routing Parameters

First path: 192 . 168 . 1 . 2

Second path: 192 . 168 . 2 . 2

Validate Send... Validate Receive... OK Cancel

9. Select “Enable Dual System Director Configuration.”
10. Configure the Virtual Addresses on both systems by doing the following:
 - a. Choose two unused static IP address that are used as the Virtual IP addresses for both System Directors. This example uses 192.168.10.253 and 192.168.20.253.
 - b. Map the Virtual IP address to the corresponding real IP address for each of the System Directors. This example uses 192.168.10.100 and 192.168.20.100.
 - c. Register both of the Virtual IPs in DNS with the Virtual System Director Name.
11. In the Local Machine area leave the Monitor port set to 5000. If you have another application that uses port 5000, change the Monitor port to an available port number. This port number must be the same on both the existing and the new System Directors.
12. Set the Local Machine First Path IP address to local IP 1: 192.168.1.1.
13. Set the Local Machine Second Path IP address to local IP 2: 192.168.2.1.
14. Set the Remote Machine First Path IP address to: 192.168.1.2.
15. Set the Remote Machine Second Path IP address to: 192.168.2.2.

The Active System Director has now been configured. Leave the Active System Director as is; stopped and with the ISIS Control Panel and Dual System Director Configuration window open.

16. Continue with [“To set up the resiliency connection on the Standby System Director:”](#) on page 97.

To set up the resiliency connection on the Standby System Director:

1. Load the ISIS software on the Standby System Director as described in “Loading the Software” on page 65.



2. In the ISIS Launch Pad, click ISIS Control Panel icon or Start > Programs > Avid > ISIS System Director and select Control Panel.

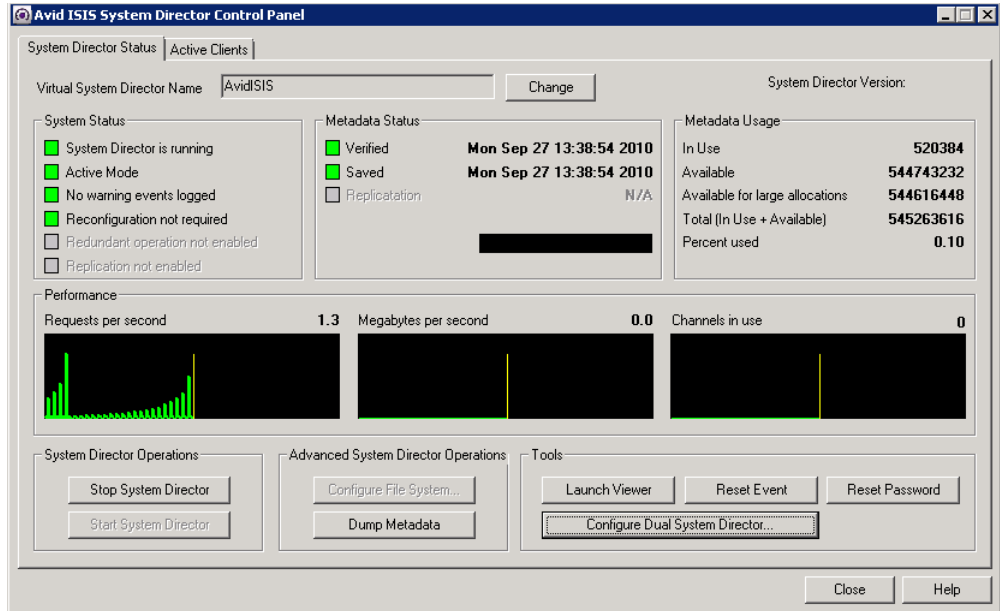

3. Click Stop System Director.

The Configure Dual System Director button becomes active.

4. Click the Change button beside the Virtual System Director Name and type a name in the Virtual System Director Name text box and click OK.



The same virtual name must be assigned to both System Directors.

5. Click Configure File System.

The File System Configuration dialog box opens.

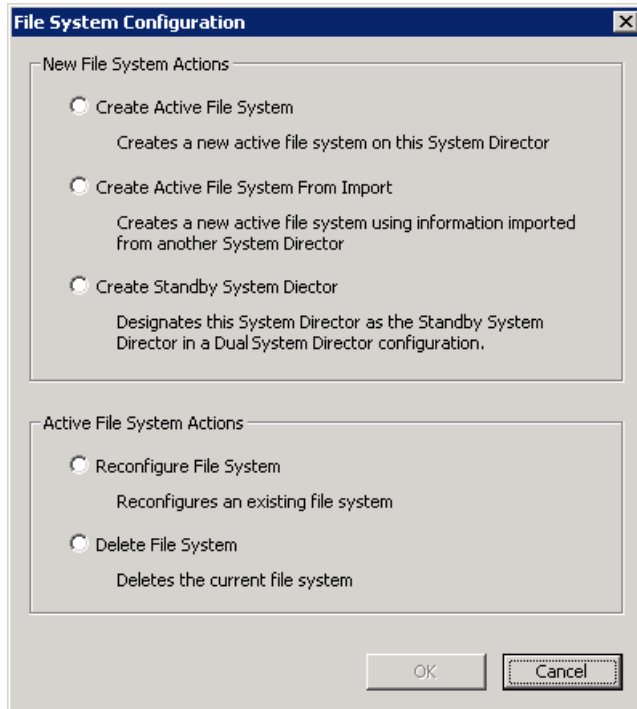

6. Select Create Standby System Director and click OK.

The Avid ISIS System Director service automatically starts when complete. In the System Director Control Panel, the “System Director is running” display turns green.

7. Click Stop System Director.

The Configure Dual System Director button becomes active.

8. Click Configure Dual System Director.

The Dual System Director Configuration dialog box opens.

Enable Dual System
Director Configuration

Dual System Director Configuration

Enable Dual System Director Configuration Local Machine Name: ISISUI1

Virtual Address

Virtual Address 192 . 168 . 10 . 253 Local interface to which the address is assigned 192 . 168 . 10 . 101

Virtual Address 2

Virtual Address 192 . 168 . 20 . 253 Local interface to which the address is assigned 192 . 168 . 20 . 101

Local Machine Routing Parameters

Monitor Port 5000

First path 192 . 168 . 1 . 2

Second path 192 . 168 . 2 . 2

Remote Machine Routing Parameters

First path 192 . 168 . 1 . 1

Second path 192 . 168 . 2 . 1

Validate Send... Validate Receive... OK Cancel

9. Select “Enable Dual System Director Configuration.”
 10. Configure the Virtual Addresses on both systems by doing the following:
 - a. Choose two unused static IP address that are used as the Virtual IP addresses for *both* System Directors. This example uses 192.168.10.253 and 192.168.20.253.
 - b. Map the Virtual IP address to the corresponding real IP address for each of the System Directors. This example uses 192.168.10.101 and 192.168.20.101.
 - c. Register both of the Virtual IPs in DNS with the Virtual System Director Name.
 11. In the Local Machine area leave the Monitor port set to 5000. If you have another application that uses port 5000, change the Monitor port to an available port number. This port number must be the same on both the existing and the new System Directors.
 12. Set the Local Machine First Path IP address to local IP 1: 192.168.1.2.
 13. Set the Local Machine Second Path IP address to local IP 2: 192.168.2.2.
 14. Set the Remote Machine First Path IP address to: 192.168.1.1.
 15. Set the Remote Machine Second Path IP address to: 192.168.2.1.
- The Standby System Director has now been configured. Leave the Standby System Director as is; stopped and with the ISIS Control Panel open.
16. Continue with [“To validate the connections:” on page 100.](#)

To validate the connections:

1. Validate the crossover connections by clicking Validate Send on the Active System Director and Validate Receive on the other System Director.
2. On the Sending System Director, you see the Red Box turn Green for each connection.

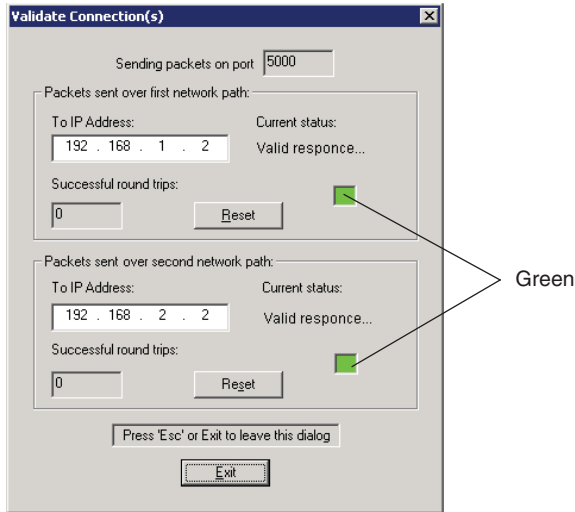

The numbers in the Packets Received boxes indicate the number of packets received from the first System Director. On the Receiving System Director you see the packets received number incrementing for each connection.

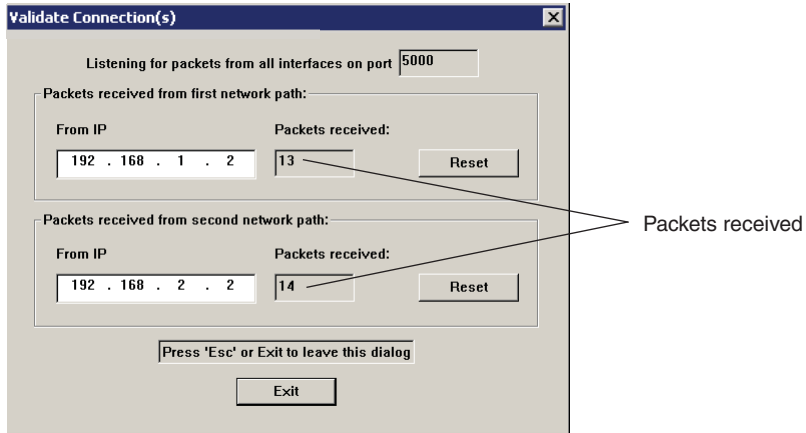

3. On each system, click Exit.

4. Repeat this validation procedure clicking Validate Send on the Standby System Director and Validate Receive on the other System Director.

Verify you are getting the same results (green indicators and correct number of received packets).

5. On each system, click Exit.

Binding Order for Health Monitoring

When you have your System Directors in a Failover configuration and use the Interplay Health Monitor with the Interplay Framework, the VLAN 10 and VLAN 20 network interface cards must be the first and second entries in the Network Interface Binding order to communicate properly.



If a network crossover connection is the first entry, the System Director Health Monitor will not display information regarding the System Director.

To set the network connection bindings order:

1. On the System Director, click Start > Settings > and double-click Network Connections.
2. Click the Advanced menu in the Network Connections window and select Advanced Settings.
3. Click the Adapters and Bindings tab.
4. If the connections for the VLAN 10 and VLAN 20 network interface cards are not in the first and second position, select them and press the Green Up arrow to move them to the top of the list.
5. Make sure the two crossover connections are at the bottom of the list.

Stopping and Restarting the System Directors

In a ISIS 2000 failover configuration, you can stop the Active System Director and watch the Standby System Director become the Active System Director. When you restart the System Director that was previously Active, that System Director now becomes the Standby System Director. If you stop and restart the Standby System Director it remains the Standby System Director. The following procedures describes how you to stop and start the System Directors.



If you have a failed System Director, stop and restart that System Director. Very often a single stop and start of the System Director corrects the problem.

To stop and start the System Director using the Launch Pad:

1. If the ISIS Launch Pad is not displayed on the Avid ISIS System Director Desktop, click the ISIS Launch Pad icon in the Taskbar's System Tray to display or hide the Launch Pad.



You can also open other ISIS tools by clicking the icons in the Launch Pad.

The ISIS Launch Pad is displayed.

**Avid © ISIS ©
Launch Pad**

- System Director -

Status

- Running ●
- No warning events logged ●
- Reconfiguration not required ●
- Licenses in use **1 of 100**
- Virtual name **AvidISIS**
- Version **4.5.0.9510**

Metadata

- Loaded ●
- Status **N/A**
- In use **0.01%**
- Save time **Wed Mar 20 16:44:13 2013**
- Verify time **Wed Mar 20 16:44:24 2013**

Redundancy

- Enabled **No**
- Mode **Active**
- Replicate state **N/A**
- Replicate time **N/A**
- Path status not available **N/A**

Performance

- Messages per second **39.3**
- Write bandwidth (MB/s) **0.0**
- Read bandwidth (MB/s) **0.0**
- Open files **0**

2. Start or stop the System Director by clicking one of the following icons in the ISIS Launch Pad.



- ▶ Click the blue square icon to stop the System Director.



- ▶ Click the blue triangle icon to start the System Director.

To stop and start the System Director using the ISIS Control Panel:



1. Click Control Panel icon in the Launch Pad or Start > Programs > Avid > ISIS System Director and select Control Panel.

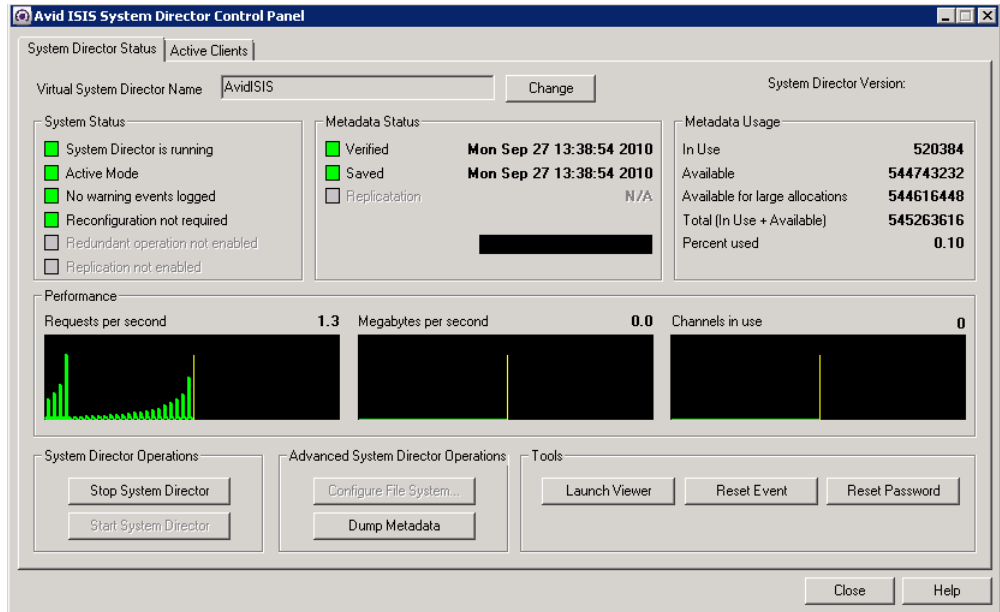

2. Start or stop the System Director by clicking the appropriate buttons in the ISIS Control Panel.
 - ▶ Click Stop System Director to stop the System Director.
 - ▶ Click Start System Director to start the System Director.

5 Avid ISIS Software Licensing

When installing a new Avid ISIS system, you need to activate the ISIS software with the Avid License Control tool. If you have a dual System Director environment, you need to repeat the procedure for each System Director.



If you change your system configuration — for example, by replacing your hard drive, replacing a network adapter, or by upgrading your operating system — you must first deactivate your Avid software. For information on deactivation, see “[Deactivating the License](#)” on page 109.

- New installations — if you are a new user and have never installed the Avid software on your system, use the following instructions.



Your network administrator might need to open a few ports that are used during the licence activation. The Avid License Control tool utilizes both port 3443 and port 443 for license request and response communication. Port 3443 is the primary port, but if this port is blocked, the Activation Service tries port 443 (which is more likely to be open for web communication).

- Existing installations — if you are upgrading from a previous version of the Avid ISIS software, your Avid ISIS software license remains activated. You do not need to reactivate your Avid ISIS software license as long as you've previously activated a licence or have a valid ISIS application key (dongle) connected.
- Host name changes — if you change the host name of your system Director you must first deactivate your license, delete the license binding file, and reactivate the license with the new name, see “[License Requirement with Host Name Change](#)” on page 110.

What You Need to Activate the ISIS Software License

Identification (ID) Numbers Where you can find them:

Activation ID

The Activation ID is provided on an Activation ID and System ID card shipped with your new ISIS system. The Activation ID is used to activate the software license and has been linked to your System ID.

Identification (ID) Numbers Where you can find them:

System ID	<p>The System ID is provided on an Activation ID and System ID card shipped with your new ISIS system. The System ID is used for expediting warranty verification and customer service.</p> <p>Once activated, the License Profile tab of the Avid License Control tool displays information about your system. Click “Copy to Clipboard” to copy the information to your Clipboard. You can then cut and paste from the clipboard to an e-mail or create a text file. This is helpful if you need to save this information for your records or need to send system information to Avid Customer Support.</p>
Device ID	<p>The Device ID is only needed if you are activating your software on a system that is not connected to the Internet. This is provided through the Avid License Control tool during activation.</p>

License Activation Using an Internet Connection

To activate the ISIS software license from the System Director with an Internet connection:

1. Locate your System ID and Activation ID card included with your new System Director.
2. Open the Avid License Control tool, click Start > Programs > Avid > Utilities > Avid License Control.

The Avid License Control tool opens.

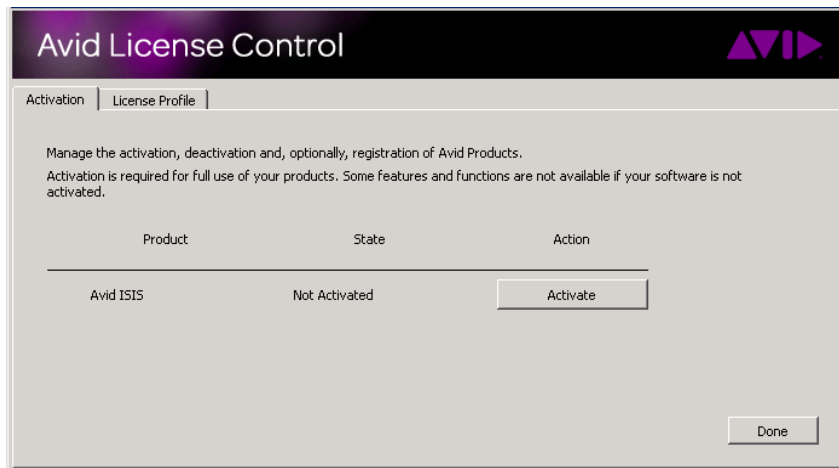

After your Avid software is activated, the License Profile tab displays your System ID, Activation ID, and Device ID.

3. Click Activate next to the Avid ISIS software.
4. Select “I am connected to the Internet and will use this computer” and then click Continue.

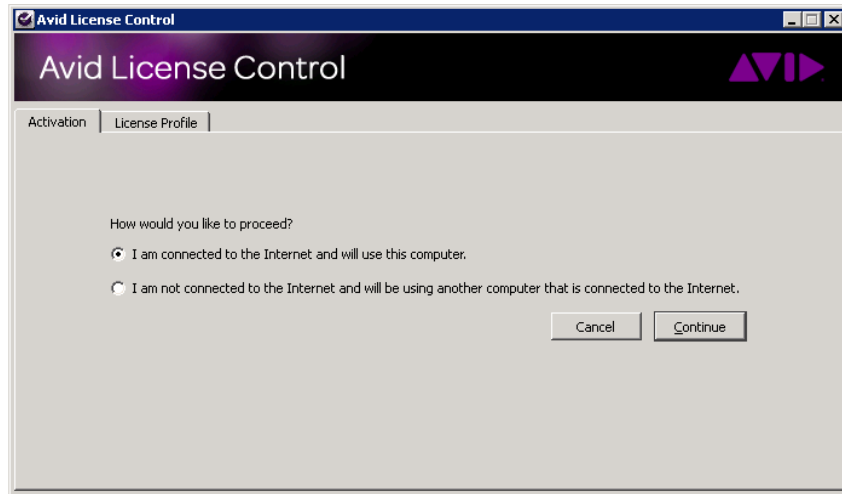

If you select “I am not connected to the Internet and will be using another computer that is connected to the Internet” continue with “License Activation Without an Internet Connection” on page 107.

5. Enter your system identification number in the System ID text box.

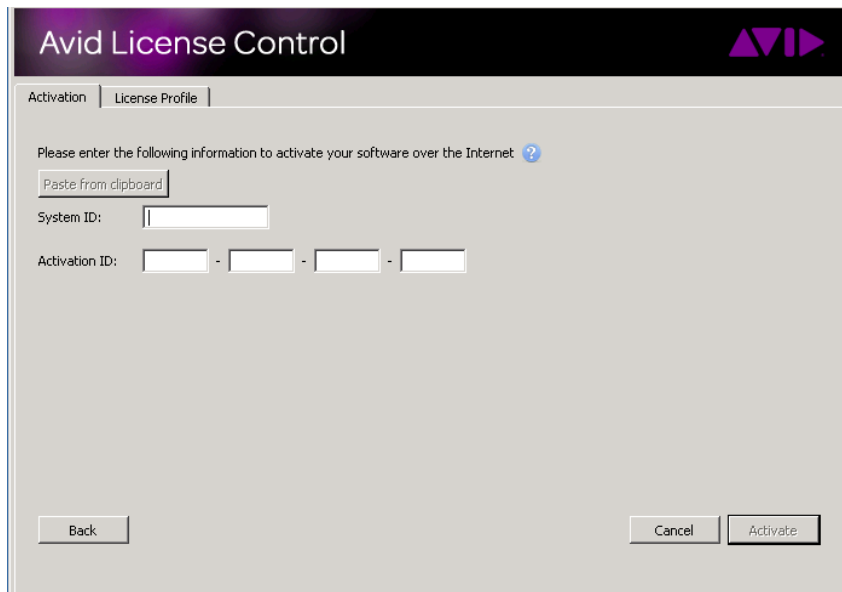

6. Enter your activation identification number in the Activation ID text box.
7. Click Activate.

The Activation tool confirms your system information. When the activation is complete, a message informs you that your software has been successfully activated and the button changes to Deactivate.

8. (Option) If you are planning a dual System Director configuration, you need to repeat this procedure to Activate your software license on your second System Director.



If you have purchased a “Resilient” System Director, both System Directors use the same System ID in a dual System Director configuration. You do need a separate Activation ID for each System Director.

License Activation Without an Internet Connection

When you do an indirect activation, you are given a “.bin” activation file. This file is only good for a single activation. If you have done an indirect activation, and deactivate your license for any reason, you cannot use the same activation file to reactivate your license. You must repeat the “License Activation Without an Internet Connection” procedure and obtain a new “.bin” activation file.

To activate the ISIS software license from a separate computer:

1. Locate your System ID and Activation ID card included with your new System Director.
2. Open the Avid License Control tool, click Start > Programs > Avid > Utilities > Avid License Control.

The Avid License Control tool opens.

3. Click Activate next to the Avid ISIS software.
4. Select “I am not connected to the Internet and will be using another computer that is connected to the Internet,” then click Continue.
5. Enter your system identification number in the System ID text box.
6. Enter your activation identification number in the Activation ID text box.
7. Click Next.
8. Follow the instructions in the Avid License Control tool, then click Next.



Your System ID, Activation ID, and Device ID are displayed on the Activation tab, write these numbers down to use later. These IDs are displayed in the License Profile tab after your Avid software is activated.

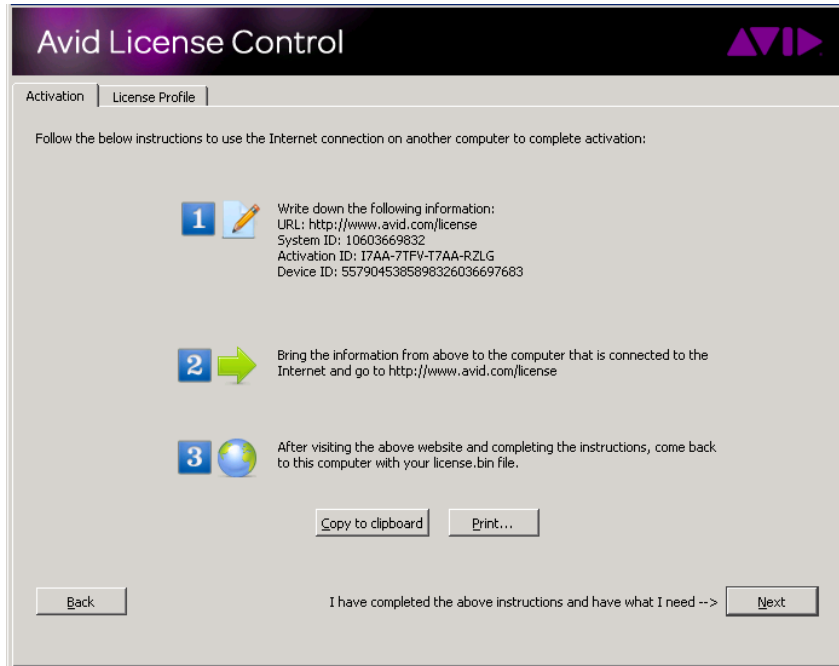

9. On a computer with an Internet connection, open a Web browser and navigate to <http://avid.com/license>.
10. Follow the onscreen instructions on the web page.
The website creates a license.bin file. This file contains license information needed to activate your Avid ISIS software.
11. Copy the license.bin file to the ISIS System Director you want to activate.
A USB flash drive is a good method of moving the license.bin file to the System Director.
12. Close the Web browser on the computer with the Internet connection.
13. Return to the ISIS System Director where you left off in the Avid License Control tool (see the illustration in step 8) and click Next.
14. Click Browse and navigate to the license.bin file on your ISIS System Director, then click Open.

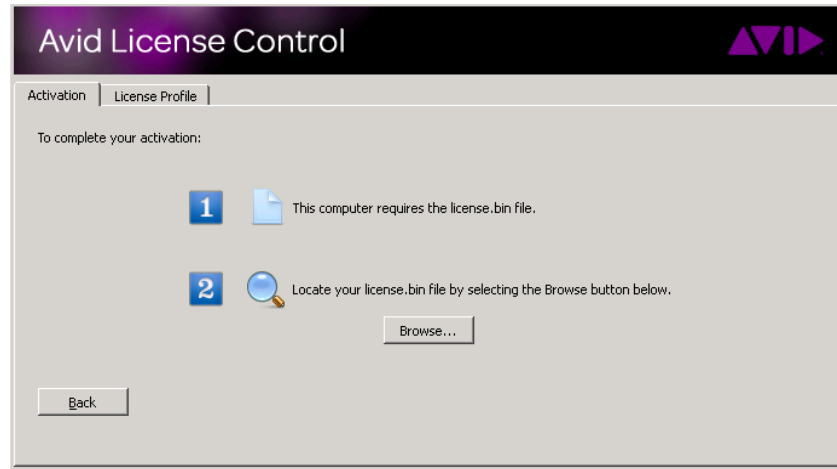

The Activation tool confirms your system information. When the activation is complete, a message informs you that your software has been successfully activated and the button changes to Deactivate.

15. (Option) If you are planning a dual System Director configuration, you need to repeat this procedure to Activate your software license on your second System Director.



If you have purchased a “Resilient” System Director, both System Directors use the same System ID in a dual System Director configuration. You do need a separate Activation ID for each System Director.

Deactivating the License

You must deactivate your ISIS software license when replacing the System Director so you can use the license on your new System Director. If you need to deactivate the ISIS software you must have an Internet connection to deactivate the software and its options.

Deactivating the ISIS System Director software:

1. Stop your Avid ISIS System Director.
2. Open the Avid License Control tool, click Start > Programs > Avid > Utilities > Avid License Control.

The Avid License Control tool opens.

3. Next to the Avid ISIS software, click Deactivate.
4. Click Yes.

The system deactivates and the button changes to Activate.

5. Click Done to close the window.

License Requirement with Host Name Change

If you want to change the host name of your System Director, you must deactivate your ISIS software license, delete the license binding file, and reactivate the license after changing the host name.

When changing the System Director host name:

1. Deactivate the Avid License on your Avid ISIS System Director (see [“Deactivating the License” on page 109](#)).
2. Browse to the following location on the System Director and delete the “binding.dat” file.
`c:\ProgramData\Avid\Common\binding.dat`
3. Change the System Director host name.
4. Restart the System Director.
5. Reactivate the Avid License on your Avid ISIS System Director (see [“What You Need to Activate the ISIS Software License” on page 104](#)).

6 Configuring the Server for CIFS Access

This chapter describes how to configure the ISIS 2000 System Director for Common Internet File System (CIFS) clients. The ISIS and CIFS clients share traffic on the same network port on the back of the server.



Only System Directors with a 10 Gb connection to the switch support CIFS clients. The recommended bandwidth setting is 100 MB/s so that there is little impact to ISIS clients.

If you have previously disabled the CIFS service because of a 1 Gb connection with the System Director, you need to Start the CIFS service again. Revise these instructions [“Turning Off the CIFS Service With a 1 Gb Connected System Director” on page 79](#). This chapter contains the following sections:

- [Creating Windows Users and User Groups on the System Director](#)
- [Adding Users and Setting Permissions](#)
- [Mapping Network Workspaces on CIFS Clients](#)

Creating Windows Users and User Groups on the System Director

You must add Windows users and user groups to the Avid ISIS System Director using the standard Windows operating system process. The following procedures are provided to help with that process, but for details on creating user and group accounts on the System Director, right-click on the Local Users and Groups folder in the left pane of the Computer Management window and select Help.

To create a local user account:

1. Right-click on My Computer and select Manage.
The Computer Management Window opens.
2. Expand Configuration > “Local Users and Groups” folder in the left pane.
3. Click Users.
4. Click Action > New User.
5. Type the appropriate information in the dialog box.

6. Select or clear the appropriate check boxes:
 - User must change password at next logon
 - User cannot change password
 - Password never expires
 - Account is disabled
7. Click Create, and then click Close.

To create a local group:

1. Right-click on My Computer and select Manage.
The Computer Management Window opens.
2. Expand the “Local Users and Groups” folder in the left pane.
3. Click Groups.
4. Click Action > New Group from the menu bar.
5. In Group name, type a name for the new group.
6. In Description, type a description of the new group.
7. To add one or more members to the new group, click Add.
8. In the Select Users, Computers, or Groups dialog box, under “Enter the object names to select,” type the name of the user account or group account that you want to add, and then click OK.
9. In the New Group dialog box, click Create, and then click Close.

Adding Users and Setting Permissions

The ISIS File Gateway software includes an application called the Configuration Editor that allows the File Gateway administrator to create a configuration file listing the authorized users with permission to specific workspaces.

Before adding CIFS users, make sure the users are already Windows users listed on the ISIS System Director, see [“Creating Windows Users and User Groups on the System Director” on page 111](#).

To add CIFS users and workspaces:

1. On the System Director, click Start > Programs > Avid > ISIS File Gateway and select Configuration Editor.

The Configuration Editor window opens.

2. If the System Login dialog box is not displayed, click the Connect button in the top toolbar of the Configuration Editor window.

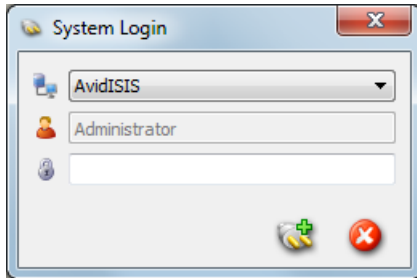

3. Select the ISIS System you want to connect to.
4. Type the Administrator's password in the text box.



You must be an Administrator to use the Configuration Editor. You cannot type in other user names.

5. Click the Connect button.
6. Move the Bandwidth slider to the bandwidth speed you want available to the users, you can also type in the value in the text box next to the slider.

Bandwidth can be set between 40 and 1200, the default value is 100. You cannot set separate bandwidth speeds to individual users.

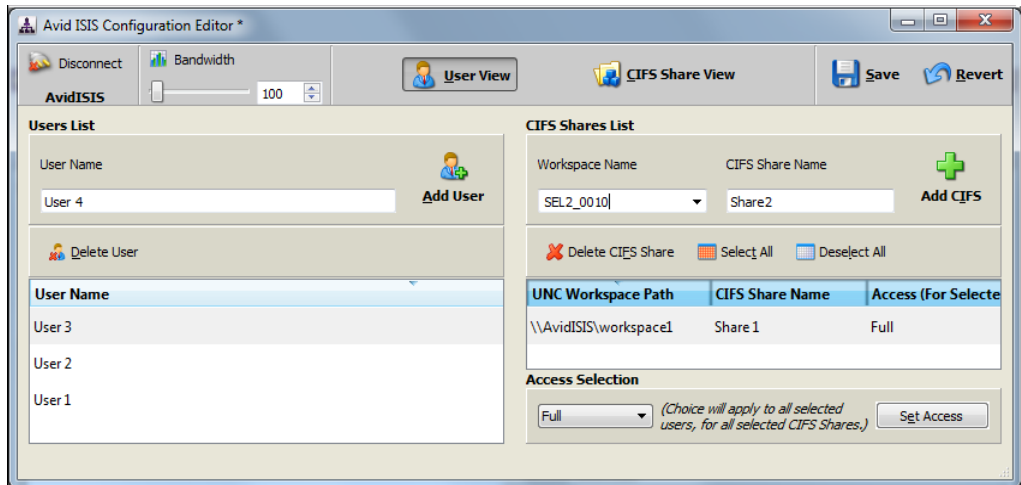

7. Type the *user_name* in the User Name text box and click Add User.

User name must match the Windows user names created on the System Director.

8. Repeat step 7 until all the users have been added.
9. With a User Name selected, select or start typing the name of the workspace you want shared in the Workspace Name text box.
10. Type the name you want display on the CIFS client in the CIFS Share Name text box.
11. Click Add CIFS.
12. Continue with setting the permissions.

To set CIFS user permissions:

1. Open the Configuration Editor (if not already open), click Start > Programs > Avid > ISIS File Gateway and select Configuration Editor.
2. Select a user in the left pane and one or more workspaces in the right pane.
3. Set the permissions using the Access Selection menu:
 - None — no access
 - Full — read, change, and full control
 - Read — read permission
 - Read/Write — read and change permission
4. Click Set Access.
5. Repeat steps 2 and 4 until permission have been set for all users.
6. Click Save.

The file is read immediately and you do not need to restart the System Director.
7. Click the Close button (X) in the corner of the windows to exit the application.

To set multiple user permissions to a single workspace:

1. Open the Configuration Editor (if not already open), click Start > Programs > Avid > ISIS File Gateway and select Configuration Editor.
2. Click CIFS Share View.
3. Select a workspace in the left pane and one or more users in the right pane.
4. Set the permissions using the Access Selection menu:
 - None — no access
 - Full — read, change, and full control
 - Read — read permission
 - Read/Write — read and change permission
5. Click Set Access.
6. Repeat steps 3 and 5 until permission have been set for all workspaces.

7. Click Save.

The file is read immediately and you do not need to restart the System Director.



The file is saved as configFile.txt in C:\Program Files\Avid\ISIS Client\FileGateway folder. The files is overwritten each time you click Save. If you make changes in the Configuration Editor and want to return the last saved file, click Revert.

8. Click the Close button (X) in the corner of the windows to exit the application.

Setting the CIFS Bandwidth

The default bandwidth for the System Director when configured for CIFS is 100 MB/s. The System Director is an ISIS client and all the CIFS users are clients of the CIFS server. You can define the System Director bandwidth from 40 MB/s to 1200 MB/s using the Configuration Editor, see [“Adding Users and Setting Permissions” on page 112](#).



Only System Directors with a 10 Gb connection to the switch supports CIFS clients. The recommended bandwidth setting is 100 MB/s so that there is little impact to ISIS clients.

Mapping Network Workspaces on CIFS Clients

CIFS clients should map network workspaces to their system for a convenient shortcut to the workspace. You can map multiple workspaces.

To map a workspace to a CIFS client (Windows):

1. Click Start > Run on the CIFS client.
2. In the Open text box, type the path of the workspace on the cooperate domain, for example \\FileGateway_server_name\shared_workspace_name and click OK.
3. In the Windows Explorer window that opens, click the Tools menu and select “Map Network Drive.”

To map a workspace to a CIFS client (Macintosh):

1. In the Apple menu, click Go > Connect to Server.
2. In the Open text box, type the path of the workspace on the cooperate domain, for example cifs://FileGateway_server_name/shared_workspace_name and click Connect.
3. In the Windows Explorer window that opens, click the Tools menu and select “Map Network Drive.”

7

Configuring the Server for FTP Access

This chapter describes how to configure the System Director to share Avid ISIS workspaces using File Transfer Protocol (FTP). The FTP function is done through the Microsoft® Internet Information Services (IIS) and the FTP Service.



Only System Directors with a 10 Gb connection to the switch support FTP clients.

Once you have configured the FTP service on your ISIS 2000, Avid recommends the following FTP client applications.

- Microsoft Expression Web 4
- FileZilla
- Core FTP LE
- SmartFTP Client

For information on configuring Microsoft FTP Server Sites, see <http://support.microsoft.com/kb/283679>.

Several FTP functions and settings have been pre-configured for you in the operating system image of the ISIS 2000 System Director and the software. The FTP service is not started automatically, use the following procedures to enable the FTP server for FTP client access to the data on the ISIS 2000 storage. The following are FTP configurations used in the ISIS 2000 System Director:

- The FTP Service uses port 21 and should not be changed
- In Bindings, you need to enter an virtual host name
- In Virtual Directory, enter Alias ISIS Workspace names (for example WorkspaceA)
- An FTP directory (D:\ftproot) has been created for the alias workspaces
- You set the access privileges to the Workspaces when you add the FTP users the Windows operating system

In addition, the “Blade FTP Share” FTP site is also preconfigured on the ISIS 2000 System Director. The “Blade FTP Share” FTP site is used for upgrading the media drives during software upgrades and providing Client Manager software to ISIS clients. The Blade FTP Share install location is: C:\Program Files (x86)\Common Files\Avid ISIS Shared\ftp.



Do not modify any settings in the “Blade FTP Share” FTP Site, or its sub-folders. Any changes to the Blade FTP Share could potentially prevent upgrades and client installers from working properly.

Setup the System Director for FTP

The System Director shares the ISIS client and CIFS network traffic over the same Ethernet connection to the ISIS switch. Log in to the System Director as the administrator and perform the following.



The default System Director password is set to is-admin.

Creating Windows Users and User Groups on the Operating System

You must add Windows users and user groups to the Avid ISIS System Director using the standard Windows 2008 operating system process. The following procedure is provided to help with that process, but for details on creating user and group accounts on the System Director, right-click on the Local Users and Groups folder in the left pane of the Computer Management window and select Help.

To create a local user account:

1. Right-click *My Computer* and select Manage on the system.
The Server Manager window opens.
2. Expand Configuration and the “Local Users and Groups” folder in the left pane.
3. Click Users.
4. In the right-most pane, click Action > More Actions > New User.
5. Type the appropriate information in the dialog box.
6. Select or clear the appropriate check boxes:
 - User must change password at next logon (Unchecked)
 - User cannot change password (Checked)
 - Password never expires (Checked)
 - Account is disabled (Unchecked)
7. Click Create, and then click Close.

To create a local group:

1. Right-click *My Computer* and select Manage on the system.
The Server Manager window opens.

2. Expand Configuration and the “Local Users and Groups” folder in the left pane.
3. Click Groups.
4. In the right-most pane, click Action > More Actions > New Group.
5. In Group name, type a name for the new group.
6. In Description, type a description of the new group
7. To add one or more members to the new group, click Add.
8. In the Select Users, Computers, or Groups dialog box, under “Enter the object names to select,” type the name of the user account or group account that you want to add, and then click OK.
9. In the New Group dialog box, click Create, and then click Close.

Creating ISIS Users on the System Director

ISIS FTP users created on the Windows operating system must also be created on the ISIS 2000 System Director using the ISIS 2000 Management Console. The ISIS client username and password must match the username and password on the Windows operating system. For instructions on creating ISIS client users, see the *Avid ISIS Administration Guide*.

Creating a Virtual Host Name

Port 21 is a shared port between the ISIS FTP Share and the Blade FTP Share. A virtual host name must be created using a different name than the actual host name (an alias name is required). The following procedure describes how to create a virtual name.

To create a virtual host name using the FTP Site Bindings:

1. Right-click *My Computer* and select Manage on the System Director.
The Server Manager window opens.
2. In the left pane of the Service Manager window, click the plus sign (+) to expand the Roles > Web Server (IIS) > Internet Information Services (IIS) Manager.

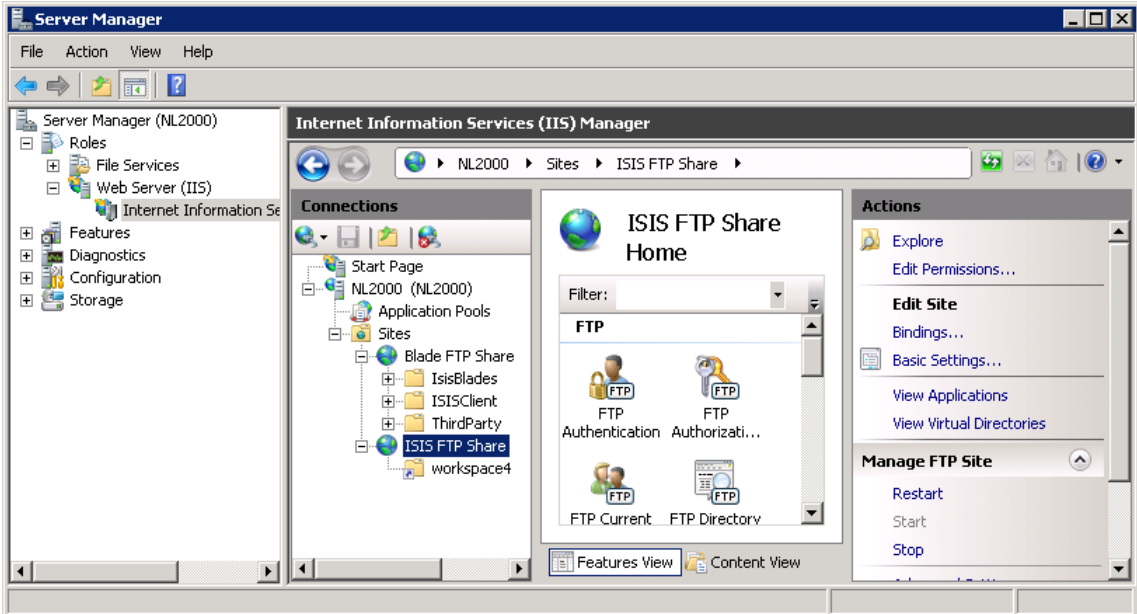

3. In the Connections pane, click the plus sign (+) to expand your *System Director name* > Sites > and select ISIS FTP Share.
4. In the Actions pane, click Bindings.
5. In the Site Bindings window, select the FTP entry and click Edit.

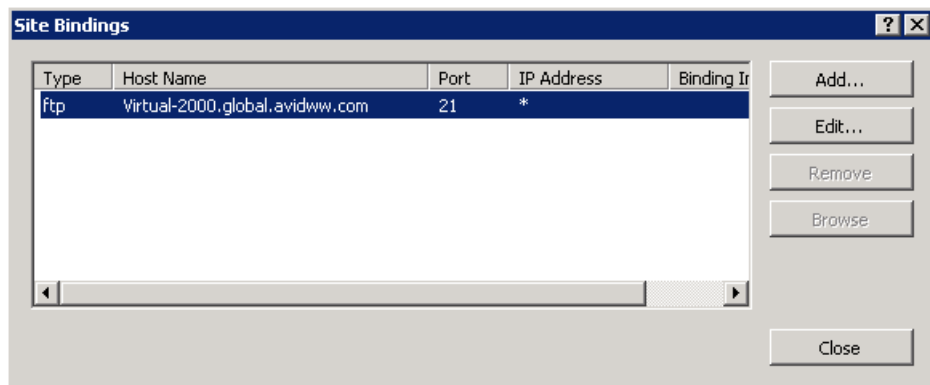

6. Enter a virtual hostname in Host name text box.



This hostname must not match the actual hostname of the System Director. It must be unique in order to share port 21 and not conflict with the Blade FTP Site. Avid highly recommends you keep the Port setting and IP Address as is.

7. Click OK.
8. Click Close.

Creating Virtual Workspaces

You must create Alias names for the accessible ISIS workspaces.

To create virtual workspaces:

1. Right-click *My Computer* and select Manage on the System Director.
The Server Manager window opens.
2. In the left pane of the Service Manager window, click the plus sign (+) to expand the Roles > Web Server (IIS) > Internet Information Services (IIS) Manager.
3. In the Connections pane, click the plus sign (+) to expand your *System Director name* > Sites > and select ISIS FTP Share.
4. In the Actions pane, click View Virtual Directories.
5. In the Actions pane, click Add Virtual Directories.
The Add Virtual Directory window opens.
6. Enter the Alias name of the workspace, for example: *workspace_name*.
7. Type the network path to the workspace in the Physical path text box (for example, *\\hostname\workspace name*).



For consistency and ease, Avid recommends that the workspace name and alias be similar.

The screenshot shows the 'Add Virtual Directory' dialog box. The fields are filled with the following information:

- Site name: ISIS_FTP_Site
- Path: /
- Alias: Workspace_name
- Example: images
- Physical path: \\system director name\workspace name

Buttons visible include 'Connect as...', 'Test Settings...', 'OK', and 'Cancel'.

8. In the Add Virtual Directory dialog box, click Connect as.
The Connect As dialog box opens.

- In the Connect As dialog box, select Specify user and click Set.

The Set Credentials dialog box opens.

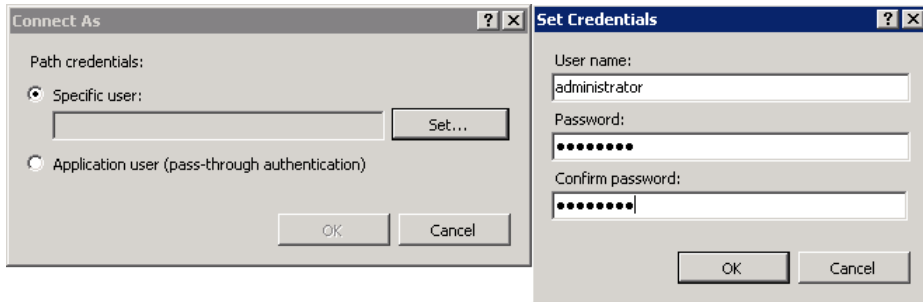

- Type **administrator** in the User Name text box and the *administrator password* in the Password text box.
- Re-type the *administrator password* in the Confirm password text box and click OK.
- Click OK to close the previous dialog boxes.

The Add Virtual Directory wizard completes and the newly created Virtual Directory is displayed in the ISIS FTP Sites folder *workspace_name*.

- Repeat these steps to create multiple workspaces.

Log In Using the Command Prompt

The following procedure describes how to access the ISIS workspace as a Windows FTP client.

To open an FTP session:

- On your Windows FTP client, click Start > All Programs > Accessories and select Command Prompt.
- Type **ftp *System_Director_hostname*** and press **Enter**.



*In the following example the virtual host name is *Virtual-2000.global.avidww.com* and the username is *ftpuser*.*

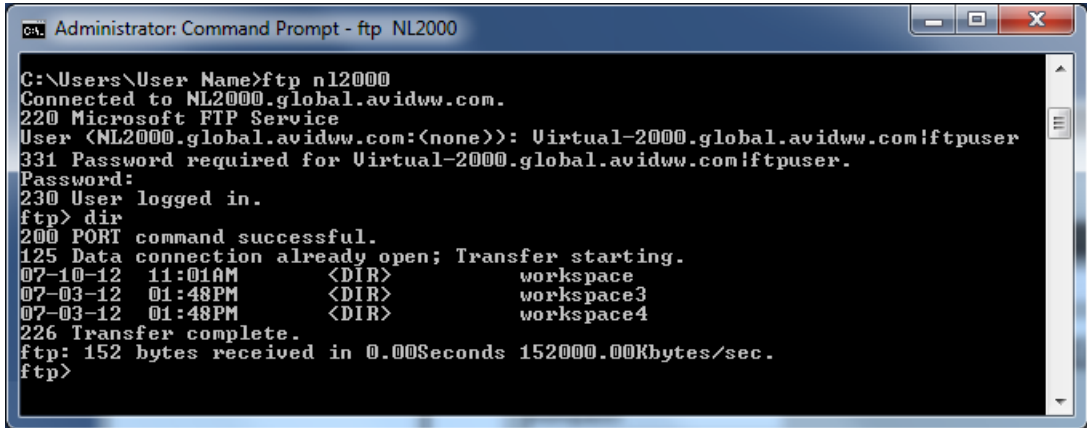

```
C:\Users\User Name>ftp nl2000
Connected to NL2000.global.avidww.com.
220 Microsoft FTP Service
User <NL2000.global.avidww.com:<none>>: Virtual-2000.global.avidww.com!ftpuser
331 Password required for Virtual-2000.global.avidww.com!ftpuser.
Password:
230 User logged in.
ftp> dir
200 PORT command successful.
125 Data connection already open; Transfer starting.
07-10-12 11:01AM <DIR> workspace
07-03-12 01:48PM <DIR> workspace3
07-03-12 01:48PM <DIR> workspace4
226 Transfer complete.
ftp: 152 bytes received in 0.00Seconds 152000.00Kbytes/sec.
ftp>
```

3. Type the *virtual_hostname* | *ftp_user_name* and press **Enter**.
4. Type the *user name password* and press **Enter**.



When finished with your FTP client session type “quit” to exit the session.

8

Avid ISIS 2000 Upgrade Guidelines

This section provides a summarized list of what tasks need to be performed when upgrading Avid ISIS 2000. All Avid ISIS upgrades are to be performed by Avid ISIS Avid Certified Support Representatives (ACSR).

The following list provides the order in which tasks need to be performed.

- If you have not already noted the host names, passwords, IP address, and other important network details, see [“Preupgrade Information” on page 134](#). Although this information needs to be gathered before you start, the pages that include the blank tables are at the end of this document.
- Do not perform an Avid ISIS system upgrade if your network is not in optimum working order, see [“Health Check” on page 123](#).
- If you have documented the preupgrade information and your Avid ISIS is healthy, you can start the Avid ISIS system upgrade, see [“Software Upgrade Process” on page 124](#).
- After you finish the upgrade, confirm everything is functioning properly, see [“Post Upgrade System Verification” on page 132](#).

Health Check

Before any changes are made to the system, perform the following quick checks to verify that the system is in good working order. Do *not* perform an upgrade if there are any issues with the system. Correct all problems before performing the upgrade.

Things to check before upgrading:

1. Log into the ISIS Management Console and click Storage Elements. All Storage Elements should be green, investigate any error statuses.
2. Ping the ISIS 2000 System Director and any other ISIS system on the network. The System Director should be accessible from any client or switch on the Avid ISIS system.
3. Ping the default gateway from System Director. This should be accessible from any point in the network. You can ping directly from the Tools > Network Utilities page in the Management Console.

4. (Dual System Director Configuration) Log into the System Director and open the System Director's Control Panel. Both paths should be up, and standby should be receiving and replicating metadata. Check the Metadata Status tab in the System Director's Control Panel. The date stamp in the saved and replicated fields should be current and updating frequently. Standby instructions only apply if there is a failover machine present.
5. Check the system event logs on the System Directors for recent error events.
6. Perform a thorough physical inspection of the network cables looking for:
 - Missing retainers, strains, sharp bends, signs of physical abuse.
 - Ensure that labels are visible, physically firmly in place, and legible.
 - Confirm that all fans and ventilation areas are free of obstructions, dirt, lint, and debris.
 - Ensure that there is clearance front and rear to allow components to be replaced without obstructions for their full chassis travel length.
 - Make sure cables are not zip tied to the power supplies or the switches.
7. (Dual System Director Configuration) Perform System Director Active to Standby Failover — Turn off one of the System Directors and verify in the System Director Control Panel that the Active Mode indicator has turned red. Turn the System Director back on and see that Active Mode displays Standby.
8. Check the system drive status on the System Director.

On the ISIS 2000 System Director, click Start > Programs > Intel -> Intel Rapid Storage Technology right-click the Intel Rapid Storage Technology icon in the task bar. The icon should be a green check mark when the drives are healthy.

Software Upgrade Process

After noting the necessary network and system component information listed in “[Preupgrade Information](#)” on page 134 you are ready to upgrade the Avid ISIS. The following is a typical procedure for upgrading the ISIS 2000 software. Read the upgrade section in the ISIS ReadMe for upgrade instructions specific to the latest release.

To upgrade ISIS 2000 v4.2 and earlier to v4.5 and later:

1. Download the ISIS software kit from the Avid Download Center (www.avid.com/US/support/downloads) to your System Director.
2. (If applicable) Log into Administrator account on the Standby System Director and Stop the Standby System Director using the ISIS Control Panel.
3. Make a copy of your current metadata files. The following are the file names and where they are located:

Metadata location

D:\Program Files\Avid\ISIS System Director

- Partition0
- Partition1
- PartitionDump.bin

4. Load the ISIS software kit on the System Director.

5. Double-click the Autorun.exe file in the software kit.

The installer detects the existing version of the installed software (if any) and displays the components that need to be upgraded in the splash screen.

6. If not already selected, select ISIS 2000 System Director from the “Select Software Package” menu.

7. Click Apply.

8. Follow the screen prompts accepting the defaults and License agreement.



When uninstalling or upgrading the ISIS 2000 software, you might get prompted to confirm the removal of the File Gateway software. Type Y to confirm the removal and continue with the upgrade.

9. Once the installation is complete, click Finish.

You are prompted now to restart the System Director. After the System Director has restarted, continue with the next step.

10. Upgrade your Storage Manager, using the ISIS Management Console > Storage Managers. Select the original Storage Manager (typically labeled SM000) and click Upgrade.

The Upgrade Storage Managers window opens.

11. Select the .zip file for the new release, and click Upgrade.

If you have an ISIS 2000-120 configuration your upgrade is finished. Continue with this procedure if you have an ISIS 2000-240 configuration.

12. (ISIS 2000-240) Select the Storage Manager from the list and click Details.

The Status for the upgrade is shown in the Details pane at the right of the window. Click the Refresh button whenever you want the updated Status. When the Status displays “Data Conversion Mode,” continue with the next step.

13. (ISIS 2000-240) Double-click the IP address of the original Storage Manager in the Details pane to open ISIS 2000 Storage Manager Agent Web page.

14. (ISIS 2000-240) You are asked for the password. Type **se-admin**.

The ISIS 2000 Storage Manager Agent page appears.

15. (ISIS 2000-240) Click Network in the left pane of the System tab.

Avid ISIS Storage Manager
192.168.0.10 / ISIS2000_Eng1

System Statistics Tools Logging Advanced

System
Status
Configuration
► Network
Time
Administration
Versioning
Show Version Information

Basic Network Configuration

Hostname

Default Gateway

Data Interfaces

	Address	Netmask	Description
gx0	<input type="text" value="192.168.0.02"/>	<input type="text" value="255.255.255.224"/>	10 Gbps Left
gx0:1	<input type="text"/>	<input type="text"/>	10 Gbps Left

Management Interfaces

	Address	Netmask	Description
ge0	192.168.0.10	255.255.255.0	1 Gbps Left

16. (ISIS 2000-240) Enter an IP address in the gx0:1 and Netmask text boxes in the Data Interfaces section.

Starting with the ISIS v4.5 release, the Engine Controller in the ISIS 2000 Engine requires dual IP addresses for ISIS 2000-240 systems. This new IP Address must be in the same subnet as the original IP address.



A second physical cable is not needed, both IP address are handled through the existing 10 Gb connection between Engine Controller and the switch.

17. (ISIS 2000-240) Click Submit.
- A dialog box appears warning you a Engine reboot is required; click the Reboot button.
 - A second dialog box appears, type `se-admin.` in the password box and click Reboot.
18. (ISIS 2000-240) When the Engine has restarted, open the Storage Manager page in the Management Console.



When you upgrade from v4.2 and earlier to v4.5 and later, you will notice there are now two Storage Managers in the Storage Managers page displaying half the capacity that was previous listed and the Status column displays “Data Conversion Mode.” This is a normal one-time behavior when you upgrade from v4.2 and earlier to v4.5 and later.



Do not add any new ISIS 2000 Engines to this existing Storage Group until the ISIS v4.5 upgrade data conversion redistribution has completed.

19. Update your Avid ISIS client software.

ISIS 2000-120 to ISIS 2000-240 Engine Upgrade

The ISIS 2000-120 has 42 media drives with two drives reserved as hot spares. The drives are configured in the Avid ISIS-120 Engine as four RAID 6 groups (10 drives in each group) with two hot spares initially created in the bottom drawer. For slot configurations, see “[Drive Array and Slot Locations](#)” on page 25.

When you convert your ISIS 2000-120 Engine to an ISIS 2000-240, you are adding 40 media drives to the open slots in the Engine. The 40 new drives are configured into four more RAID groups (10 drives in each group) for a total of eight RAID groups in the Avid ISIS-240 Engine.

Once you have updated your ISIS 2000-120 infrastructure to the latest ISIS software, that is when to update add the 40 new drives (120 TB) to the existing ISIS 2000-120 Engine and Bind the new Storage Manager. After the new Storage Manager is Bound, you can add additional ISIS 2000 Engines and Bind them. Then select all your new Storage Managers and do a single Add redistribution.

The process for updating your ISIS 2000-120 to ISIS 2000-240 Engine is as follows:

To the ISIS 2000-120 Engine to an ISIS 2000-240 Engine:

1. Update your existing ISIS 2000-120 environment (including the Engine) to the latest release.
 - a. Download the ISIS software kit from the Avid Download Center (www.avid.com/US/support/downloads) to your System Director.
 - b. (If applicable) Log into Administrator account on the Standby System Director and Stop the Standby System Director using the ISIS Control Panel.
 - c. Make a copy of your current metadata files. The following are the file names and where they are located:

Metadata location
D:\Program Files\Avid\ISIS System Director

 - Partition0
 - Partition1
 - PartitionDump.bin
 - d. Load the ISIS software kit on the System Director.
 - e. Double-click the Autorun.exe file in the software kit.

The installer detects the existing version of the installed software (if any) and displays the components that need to be upgraded in the splash screen.

- f. If not already selected, select ISIS 2000 System Director from the “Select Software Package” menu.
- g. Click Apply.
- h. Follow the screen prompts accepting the defaults and License agreement.



When uninstalling or upgrading the ISIS 2000 software, you might get prompted to confirm the removal of the File Gateway software. Type Y to confirm the removal and continue with the upgrade. “Installing the Media Drives” on page 48.

- i. Once the installation is complete, click Finish.
You are prompted to restart the System Director.
- j. After the System Director has restarted, upgrade your Storage Manager, using the ISIS Management Console > Storage Managers. Select the Storage Manager (typically labeled SM000) and click Upgrade.

The Upgrade Storage Managers window opens.

- k. Select the .zip file for the new release, and click Upgrade.

The ISIS 2000-120 upgrade is finished.

2. Access the ISIS Management Console Storage Manager Agent Page > System tab > Network and note the hostname and IP addresses.



The default Agent Administrator password is “se-admin.”

3. Stop the System Director service using the ISIS Control Panel or Launch Pad.
Once the System Director service is stopped, you can only access the Agent page in next step using the Engine IP address you have just noted.
4. Shutdown the Engine Controller using the Storage Manager Agent Web page via the Engine IP address: `https://IP_address:5015`.
 - a. Type the Administrator password into the password field.
The ISIS 2000 Storage Manager Agent page appears.

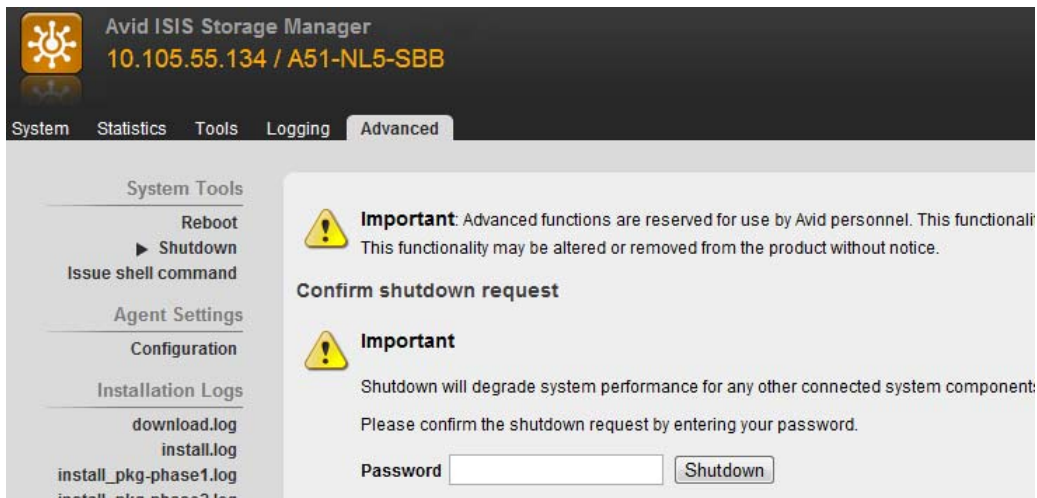

- b. Click the Advanced tab.
 - c. Select Shutdown from the left pane.
 - d. Type the Administrator password into the password field and click Shutdown.
 - e. Allow 1 minute for the buffers to clear and turn off the power to the Engine (two power supply switches).
5. Insert your new-unused ISIS drives into the open drive slots in the ISIS 2000 Engine according to the [“ISIS 2000-240 Media Drive Configuration” on page 25](#). For instructions on installing media drives, see [“Installing the Media Drives” on page 48](#).
If you have one or more used drives, you must clear the foreign configuration after they are installed in the Engine, see [“Clearing Foreign Configurations on Used Drives” on page 131](#).
 6. Power on the ISIS Engine and wait a couple minutes to let the drives come up to speed.
 7. Start the System Director service using the ISIS Control Panel or Launch Pad.
 8. Open the Storage Manager window, using the ISIS Management Console > Storage Managers.
 9. Select the original Storage Manager from the list and click Details.
 10. Double-click the IP address of the original Storage Manager in the Details pane to open ISIS 2000 Storage Manager Agent Web page.
 11. You are asked for the password. Type **se-admin**.
The ISIS 2000 Storage Manager Agent page appears.
 12. Click Network in the left pane of the System tab.

Avid ISIS Storage Manager
192.168.0.10 / ISIS2000_Eng1

System | Statistics | Tools | Logging | Advanced

System
Status
Configuration
▶ Network
Time
Administration
Versioning
Show Version Information

Basic Network Configuration

Hostname:

Default Gateway:

Data Interfaces

Interface	Address	Netmask	Description
gx0	<input type="text" value="192.168.0.02"/>	<input type="text" value="255.255.255.224"/>	10 Gbps Left
gx0:1	<input type="text"/>	<input type="text"/>	10 Gbps Left

Management Interfaces

Interface	Address	Netmask	Description
ge0	192.168.0.10	255.255.255.0	1 Gbps Left

13. Enter an IP address in the gx0:1 and Netmask text boxes in the Data Interfaces section.

Starting with the ISIS v4.5 release, the Engine Controller in the ISIS 2000 Engine requires dual IP addresses for ISIS 2000-240 systems. This new IP Address must be in the same subnet as the original IP address.



A second physical cable is not needed, both IP address are handled through the existing 10 Gb connection between Engine Controller and the switch.

14. Click Submit.

- a. A dialog box appears warning you a Engine reboot is required; click the Reboot button.
- b. A second dialog box appears, type `se-admin.` in the password box and click Reboot.

15. When the Engine has restarted, open the Storage Managers page in the Management Console.



Do not add any new ISIS 2000 Engines to this existing Storage Group until the ISIS v4.5 upgrade data conversion redistribution has completed.

16. Access the Storage Manager Agent Web page for the new Storage Manager.

17. Click RAID Diagnostics > Create RAID Config in the left pane of the Advanced tab.

This creates the RAID groups and could take several minutes, wait until a message informs you that the configuration has completed.

18. Bind your new Storage Manager, using the ISIS Management Console > Storage Managers page. For binding instructions, see “[Binding the Storage Managers](#)” on page 78.



After the new Storage Manager is Bound, you can add additional ISIS 2000 Engines and Bind them. Then select all your new Storage Managers and do a single Add redistribution. For Add redistribution instructions see the Avid ISIS Administration Guide.

19. Update the software on your Avid ISIS clients.

Clearing Foreign Configurations on Used Drives

If installing used drives into your ISIS 2000 Engine, use the following procedure to clear the configuration and make the used drive into a raw spare.

To replace a drive with a drive that is not raw:

1. To open the Storage Manager Agent, do one of the following. For more information see the *Avid ISIS Administration Guide*.
 - ▶ From the Storage Managers tool, select an IP address from the IP Addresses panel of the Details panel, and click the Info button.
 - ▶ From the Storage Elements tool, select an IP address from the IP Addresses panel of the Details panel, and click the Info button.
 - ▶ From the System Director desktop, click the “Storage Manager Agent Page” button on the ISIS Launch Pad.
2. Type the Administrator password into the password field.



The default Agent Administrator password is “is-admin.”

3. Click the Advanced tab.

If the System Status Panel in the Management Console reports a foreign disk or no spare. Use this function to clear the foreign configuration and create a spare disk. This function requires the Administrator password.



Resetting a disk is a destructive operation which will permanently delete all data currently stored on the disk.

4. Select Clear Foreign Config from the left pane.
5. Type the Administrator password into the password field.

Post Upgrade System Verification

After upgrading a system it is important to do a series of checks to verify that all upgraded components are functioning optimally.

To verify the upgrade:

1. Verify network connectivity for all components:
 - a. Ping *all* Engines.
 - b. Ping System Director from any client.
 - c. Ping the virtual System Director.
2. Verify the System Director is functioning properly by checking the following:
 - a. Check if any new errors are getting generated in the event logs.
 - b. Lights in System Director's Control Panel should be green, some lights will be blue.
 - c. Metadata should be replicating between the two System Directors. The Standby should be toggling between receiving and replicated. Check the Metadata Status tab on the standby. The date stamp in the saved and replicated fields should be current and updating frequently.
 - d. Check the RAID status on the System Director.

On the System Director, click Start > Programs > Intel -> Intel Rapid Storage Technology right-click the Intel Rapid Storage Technology icon in the task bar. The icon should be a green check mark when the drives are healthy.
3. Perform System Director Active to Standby Failover — Turn off one of the System Directors and verify in the System Director Control Panel that the Active Mode indicator has turned red. Turn the System Director back on and see that Active Mode displays Standby.
4. Run PathDiag on a client. To set PathDiag Tool:
 - a. Do one of the following:
 - (Windows) Select Start > All Programs > AvidUnityISIS > PathDiag.
 - (Macintosh) Select Go > Applications, and then double-click the AvidUnityISIS folder.
 - b. Click Start > Avid Unity ISIS Program group> Path Diag.



- c. Click Setup.
- d. Set “Path to Test” to a mounted ISIS workspace letter. (Check in my computer if not sure) Make sure its an ISIS workspace and not the internal C: drive.
- e. Set the duration 10 minutes.
- f. Click Custom Test and set the following parameters:

Custom Test Settings	1 Gb client (not bandwidth limited)	10 Gb Client (not bandwidth limited)
File Access Method	Automatically select	Automatically select
Reads vs Writes	Writes, then Reads (Sequential)	Writes, then Reads (Sequential)
Transfer Size	4096	16384
Transfer Rate	Unlimited	Unlimited
Max File Size	1000	1000

- g. Click Ok and Start.
 - 1-Gb clients that are not bandwidth limited should expect at least 65 MB/sec in the Path Diag tool.

- 10-Gb clients that are not bandwidth limited should expect at least 500 MB/sec for reads and at least 200 MB/sec for writes in the Path Diag tool.
5. While Path Diag is running check the system to make sure that there are no Network Degraded status indications. Check the following:
 - a. In the ISIS Management Console, click Storage Elements. All drives should be green and not displaying any Network Degraded states.
 - b. Check the drives by browsing to the Storage Element web page and verify you have a green indicator. Click Refresh in the Management Console page to update the page.
 6. Check your ISIS 2000 clients in Zone 2 and 3 using Path Diag.
 - a. Run a Path Diag client over each switch.
 - b. Run a couple of Zone 3 path diag clients and verify consistent performance.



ISIS 2000 does not support Zone 1 clients. A Zone 3 client might not have the bandwidth of a Zone 2 client.

Preupgrade Information

Gather the following information before the upgrade. This information is critical to troubleshooting an Avid ISIS.

- Current Avid ISIS software version
- Avid ISIS Administrator password
- Number of Avid ISIS Engines
- Drive size: 3 TB____ (currently only supports 3 TB drives)
- Number of Storage Groups
- Number and type of editing clients: (Windows or Macintosh, and using what zones)
- Number of AirSpeeds
- Other workgroup server details (for example Interplay; host names, passwords, and versions)

Zone 2 Switch Information

Note the following switch information:

- Switch manufacturer and model (Cisco/Foundry)
- Number of switches
- Location of configuration files

System Director Information

Note the following System Director information:

Virtual Network Name and IP Addresses

1 Gb port IP address

10 Gb port IP address

Virtual ISIS Name

System Director

Host name

Administrator Password

IP address

ISIS IP Address

Default Gateway

First failover IP address

Second failover IP address

System Director 2

Host name

Administrator Password

IP Address

Left ISIS IP Address

Left Default Gateway

Right ISIS IP Address

Right Default Gateway

First failover IP address

Second failover IP address

ISIS Engine Information

Fill out the following Engine IP address information for the on site equipment.

Engine #1, Serial Number

Engine IP:

Engine #2, Serial Number

Engine IP:

On Site Spares

List all Avid ISIS spare parts that are onsite:

Spare Components and Cables

Part	Quantity	Firmware Version (if known)
Drives		
XFP, X2, and SFP+ (used with external switches)		N/A
Intel® network boards		
10-GB fiber cable		N/A
CAT5e/6/7 cable		N/A
Xenpack® (if Cisco)		
3rd party switches		
Additional Parts Available		

Spares Checklist

Use the following list to assure that you have the correct parts onsite when performing *any* Avid ISIS upgrade. This can be a mix of customer spares and parts brought onsite by upgrade technicians.

- 2 — drives
- 1 — SFP+

Additional spares for a comprehensive spares parts list:

- If Cisco switches are in use: 1 Xenpack, 1 SC-LC cable
- If Force10 switches are in use: 1 additional SFP+, 1 LC-LC cable

9 Avid ISIS Recommended Maintenance

The following maintenance recommendations are not meant to be a troubleshooting guide but more of a care and monitoring checklist for Avid ISIS. Typically the Avid ISIS does not need to be power cycled. All components of the ISIS stack can individually be replaced or restarted without interfering with the operation of ISIS stack.



Power cycling the entire stack (all the components at the same time) could risk the stability of the ISIS stack.

For information on using the tools described in this section, see the *Avid ISIS Administration Guide*.

Minimum Storage Space Requirement

The recommended amount of space you must maintain for background functionality and failures is 5% of free space in each Storage Group. In other words, you should not fill Storage Group more than 95% full. Exceeding 95% used space can produce severe performance issues in some situations.

To calculate the right amount of free space, log into the ISIS management Console and navigate to the Storage Group window. For each Storage Group, take the Effective number and multiply by 0.05. This will be your recommended free space in GBs. To assure that your Storage Group never exceeds the recommended amount of space, create a new workspace in this Storage Group with the recommended free space and label it “Headroom” and do not give anyone access to this workspace.

Daily Maintenance

The following contains a list of items you should do on a daily basis. It is estimated to take 15 minutes to perform these functions.

- Check the Storage Elements status: Open the ISIS Management Console and click Storage Elements.
 - You should see a green circle beside the Storage Elements in the Name column
 - Check the Status column for errors or Network Degraded

The Status column in the Storage Elements report the status of the storage element logged by the System Director. (The Status line in the Details area reports the same information.) When the storage element maintains a working status, the Management Console displays no entries in the Status field. If a problem arises, or when the status of the Storage Element changes, the Management Console updates the Storage Elements dialog box.

- Start the Management Console and check the Error, Warning and Info tabs in the System Status Console for errors.

Information is displayed in blue and errors display as red or yellow components with a warning icon.

- Check System Director Control Panel for errors, make sure there are no red indicators in the status box.
 - Check for green indicators beside the “System Director is running”
 - Check that a blue or green indicator is displayed beside “Replicated” on the *Active* System Directory
 - If the event log indicator is not green, check the Windows Event logs on the *Active* System Director
- Check System Director Control Panel on the *Standby* System Director for errors.
 - Verify the Standby System Director is “Started” and in “Standby” Mode. Check for green indicators beside the “System Director is running” and “Both paths are up”
 - Check that a blue or green indicator is displayed beside “Receiving”

- If the event log indicator is not green, check the Windows Event logs on the *Standby* System Director
- Check that the Avid ISIS Workspaces have “Free Space” available: Open the ISIS Management Console and click Workspaces, see [“Minimum Storage Space Requirement” on page 138](#).

Weekly Maintenance

The following contains a list of items you should do on a weekly basis. It is estimated to take 30 minutes to perform these functions.

- Review Windows Event logs on the System Directors
- Check the network connections using the Management Console > Tools > ISIS Toolbox > Connection Analyzer. All Storage Elements should be green.
- Check the RAID status on the System Director.
On the System Director, click Start > Programs > Intel -> Intel Rapid Storage Technology right-click the Intel Rapid Storage Technology icon in the task bar. The icon should be a green check mark when the drives are healthy.
- Make sure you have at least one 5% worth of free space in the Storage Group, see [“Minimum Storage Space Requirement” on page 138](#).

Saving ISIS Metadata

This procedure describes how to save the metadata stored on the system drives in the ISIS System Director. This procedure would typically only be needed in the event of a hardware replacement where both system drives or the System Director server itself will be replaced in an active ISIS installation.

Regardless of how many Engines you have, all the metadata for all the media drives, in all of the Engines, are saved on the System Director. The Engines do not store any metadata.

To save the System Director metadata:

1. Stop the System Director service using the ISIS Control Panel.



The System Director is constantly writing metadata. Metadata files are always open and locked, so the best way to copy the metadata files is to stop the System Director service so the files are closed.

2. Copy the Partition0 and Partition1 files from the following location on the System Director:

D:\Program Files\Avid\ISISSystemDirector



There is also a PartitionDump.bin file. This file is also helpful when identifying the data on the media drives. If possible, include this file with the two Partition metadata files.

The following are a couple suggested ways of saving the Partition0 and Partition1 PartitionDump.bin files.

- Use a USB flash drive that has the capacity for the Partitionx files (at least a 4 GB USB is recommended).
 - Create a network share on a client system on the network and copy the Partitionx files to that shared folder.
3. Verify that you have the current copy of the Metadata by comparing the date in the Metadata tab of the ISIS control Panel.
 4. Start the System Director service using the ISIS Control Panel.

Available Utilities

The following is a list of headings in the *Avid ISIS Administration Guide* that describe other utilities and tools for monitoring and troubleshooting.

- Avid ISIS System Director Control Panel
- ISIS Management Console
 - Changing the Administration Password
 - Setting up Error Notification
 - Avid ISIS Snapshot Tool
 - Using the Profile Tool
- System Statistics
- System Logging
 - Accessing the Logging Window
 - Viewing Event Logs
- Avid ISIS Connection Analyzer Tool
- Avid ISIS Log Aggregator Tool
- Avid ISIS Disk Analyzer Tool

- Avid ISIS Agents
 - Agent Tools
 - Log Viewer Tool
- System Director event message meanings

Client Manager Maintenance

If you suspect a poor connection between your client system and a mounted workspace, you can test the Avid ISIS shared storage network connection between each client system and the shared storage network using the Avid PathDiag tool. This tool informs you if there is sufficient read/write throughput for read and write operations needed by the client system. For more information on using the Avid PathDiag tool see, *Avid ISIS Client Manger Guide*. This guide also describes the following Administrative tasks:

- Clearing Cached Data
- Using Logs and Messages

Status Indicators and Troubleshooting

If the LEDs on the Engine or drives are indicating a problem, identify the problem using the information under, [“Status LEDs” on page 144](#).

Complete Server Room Shutdown

There is no requirement to power cycle the entire Avid infrastructure but, if the need arises to turn off *all* the equipment (such as a relocating the server room), turn off the components in the following order. When turning on the component, use the reverse order.

To shut down the entire Avid network (server room):

1. Shutdown all Avid editing system and attached media I/O equipment, for example Avid Mojo and Avid Adrenalines.
2. Shutdown all capture and playout servers such as AirSpeeds.
3. Shutdown CaptureManager Server.
4. Shutdown Interplay Transfer Server.
5. Shutdown Avid Interplay Media Services and Providers.
6. Shutdown Interplay Engine and Avid Interplay Archive Engine.
7. Shutdown Media Indexers — Do not stop the Media Indexer while it is indexing storage.
8. Shutdown Systems running Interplay Framework Multicast Repeaters.
9. Shutdown Systems running the Interplay Framework Lookup Service.

10. Invoke a Failover on your Avid ISIS 5500 | 5000 and ISIS 7500 | 7000 System Directors.
11. Shutdown Standby Avid ISIS System Director.
12. Shutdown Active Avid ISIS System Director.
13. Shutdown Avid ISIS Engines.
14. Shutdown the network switches.



Power up the entire rack of equipment in reverse order and verify all clients have mounted the necessary ISIS Workspaces.

10 Status LEDs

This chapter provides an explanation of the light-emitting diodes (LEDs) located on the different sections of the Avid ISIS 2000 Engines. The following sections are included:

- [Status LEDs](#)
- [Hardware Faults](#)
- [Front Panel LEDs](#)
- [Drawer LEDs](#)
- [Power Supply LEDs](#)
- [Cooling Module LEDs](#)
- [Media Drive LED](#)
- [Engine Controller LEDs](#)
- [Thermal Sensors](#)



When the Engine is powered on, all LEDs are lit for a short period to ensure that they are working. This does not indicate a fault unless the LEDs remain lit after a few seconds.

Hardware Faults

LED colors are used consistently throughout the Engine and its components for indicating status:

- Green – good or positive indication.
- Flashing green/amber – non-critical condition.
- Amber – fault.

Ensure that you have obtained a replacement module before removing any faulty module.



If the Engine is powered up and you remove a module, replace it immediately. If the system is used with any modules missing for more than a few seconds, the Engine can begin to overheat, causing power failure and data loss.



Observe all conventional ESD precautions when handling Engine modules and components.

If the System Director and ISIS Engine are not communicating:

- Check that the network cables from the Engine and the System Director are cabled to the same ISIS switch.
- Check the indicators on the Engine Controller (see [“Engine Controller LEDs” on page 151](#)).
- Verify that the device driver for the operating system are operating properly.

Front Panel LEDs

The front panel LEDs displays the aggregated status of all the modules and indicate the following functions:

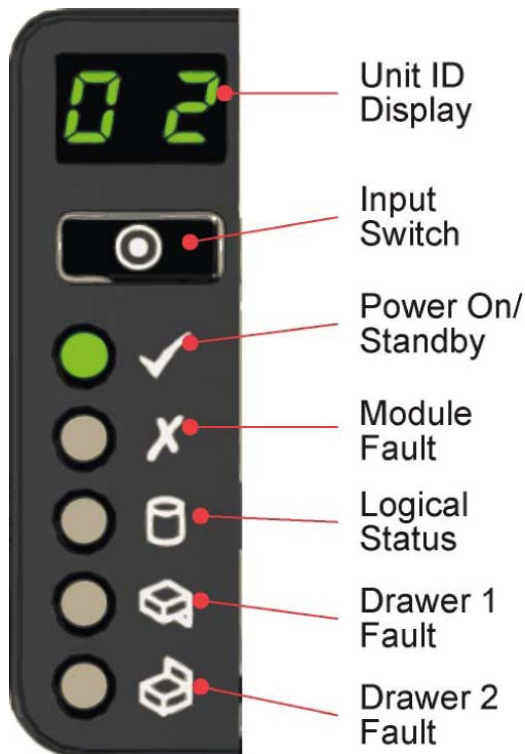

Cooling Module LEDs

LED	Description
Unit Identification Display	Usually shows the identification number for the Engine, but can be used for other purposes.

Cooling Module LEDs (Continued)

LED	Description
Power On/Standby LED	Amber if the system is in standby. Green if the system has full power.
Module Fault LED	Amber indicates a fault in a power supply, cooling module or Engine Controller. Check the drawer LEDs to see if a drive fault is indicated (see “Drawer LEDs” on page 146).
Logical Status LED	Amber indicates a fault from something other than GEM (usually a media drive fault, host bus adapter, or RAID controller). Check the drawer LEDs to see if a drive fault is indicated (see “Drawer LEDs” on page 146)
Drawer 1 Fault LED	Amber if there is a drive, cable or sideplane fault in drawer 1. Open the drawer and check the media drive LEDs for faults.
Drawer 2 Fault LED	Amber if there is a drive, cable or sideplane fault in drawer 2. Open the drawer and check the media drive LEDs for faults.

Drawer LEDs

The drawer LEDs indicate the following functions:

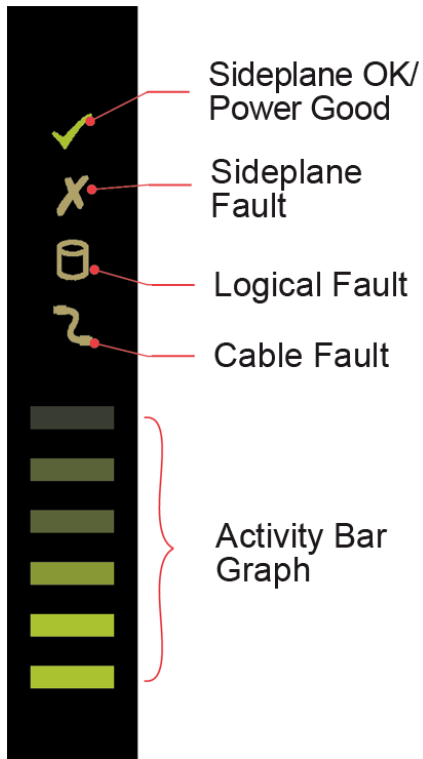

Drawer LEDs

LED	Description
Sideplane OK/Power Good	Green if the sideplane card is working and there are no power problems.
Sideplane Fault	Amber if a drive has failed. Replace the drive.
Logical Fault	Flashes amber if one or more arrays are in an impacted state.
Cable Fault	Amber if the cabling between the drawer and the back of the Engine has failed.
Activity Bar Graph	Shows the amount of data I/O from zero to six segments lit. When no segments are lit, there is no data I/O activity. When all six segments lit, the maximum data I/O activity.

Power Supply LEDs

When you first encounter a problem with the power supply, check for:

- Missing or damaged power cords
- Incorrect or ungrounded circuits
- Proper power is supplied to the Engine

The power supply LEDs indicate the following functions:



When the Engine is powered on, all LEDs are lit for a short period to ensure that they are working. This does not indicate a fault unless the LEDs remain lit after a few seconds.



If a power supply's firmware is being programmed and the download fails, the power supply LEDs will flash.

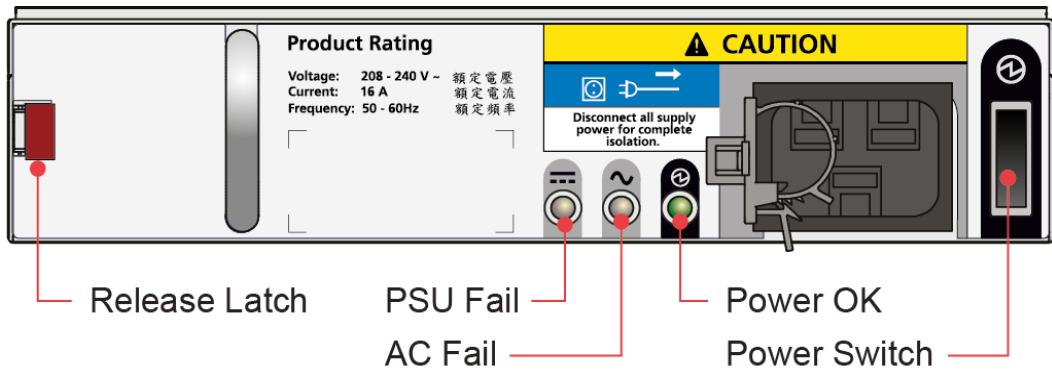

Power Supply LEDs

Power Supply Fail (Amber)	AC Missing (Amber)	Power (Green)	Status
Off	Off	Off	No AC power to either power supply.
On	On	Off	Power supply present, but not supplying power or power supply alert state (usually due to critical temperature).
Off	Off	On	AC present and switch on. This power supply is providing power.
Off	Off	Flashing	AC present and power supply in standby (other power supply is providing power).

Power Supply LEDs (Continued)

Power Supply Fail (Amber)	AC Missing (Amber)	Power (Green)	Status
Flashing	Flashing	Off	Power supply firmware downloading. If the download fails, the power supply LEDs will flash.
Off	On	Off	AC power missing, power supply in standby (other power supply is providing power).
On	On	On	Software has lost communication with the power supply.
On	—	Off	Power supply has failed. Replacing Power Supply, see “Power Supply Replacement” on page 165.

Cooling Module LEDs

The Cooling Module LEDs indicate the following functions:

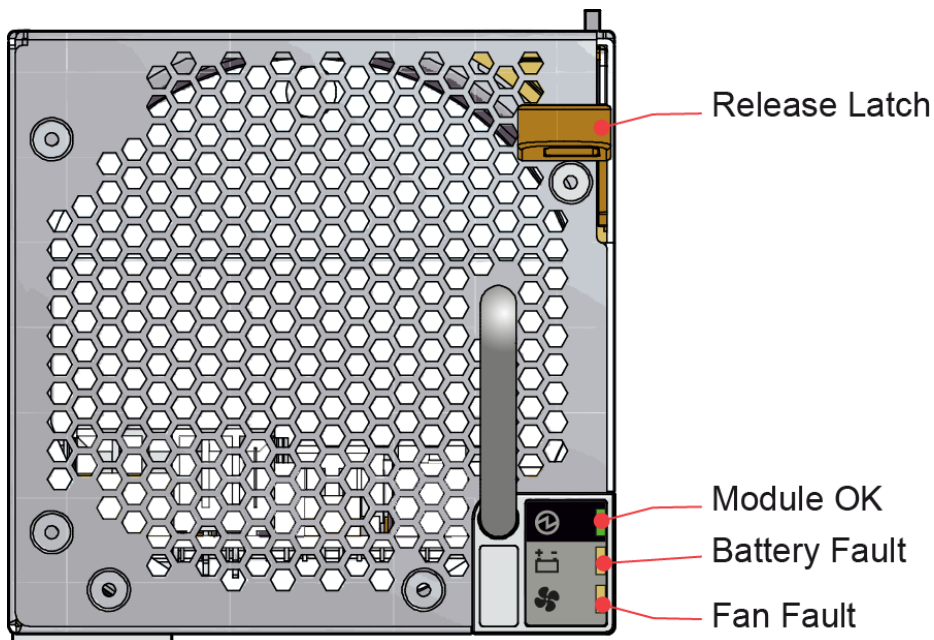

Cooling Module LEDs

Led	Description
Module Ok	Constant green indicates that the fan is working correctly. If the green LED is off, the fan has failed. Replace cooling module, see “Cooling Module Replacement” on page 164 .
Battery Fault	Battery backup is not used in this product.
Fan Fault	Amber indicates that a fan has failed. Replace cooling module, see “Cooling Module Replacement” on page 164 .

Media Drive LED

Each media drive has a single amber drive fault LED as shown in the following illustration. When lit, this indicates a drive failure – the drive should be replaced as soon as possible.

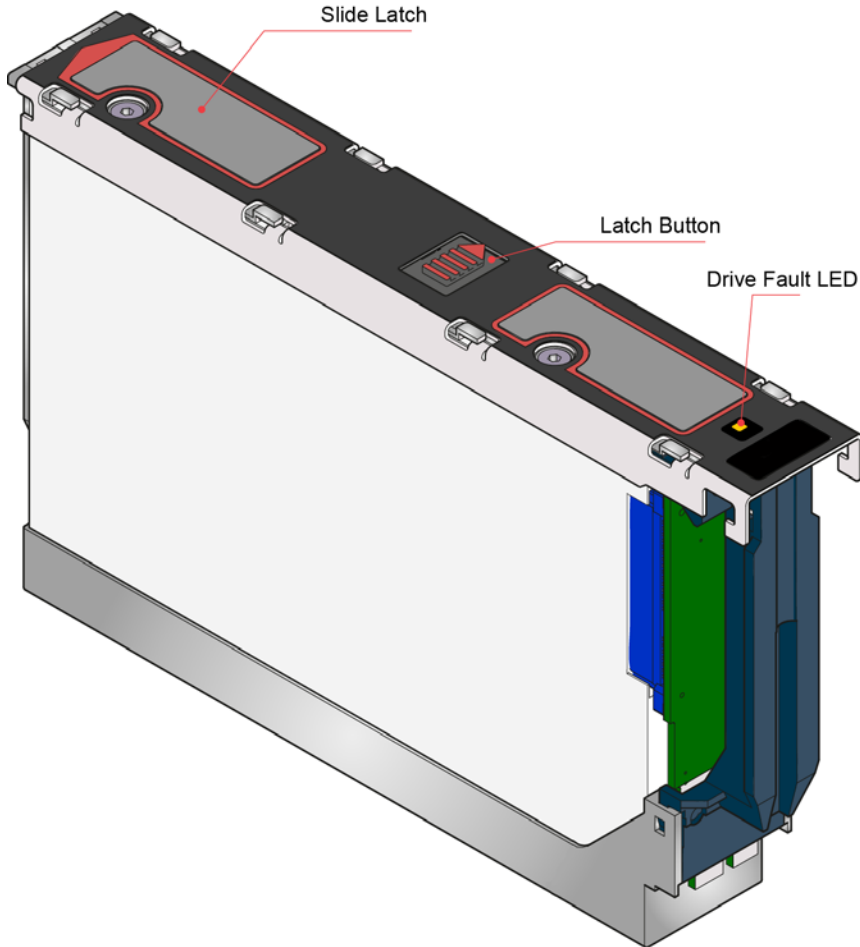

Engine Controller LEDs

The LEDs on the Engine Controller are shown in the following illustration and table.

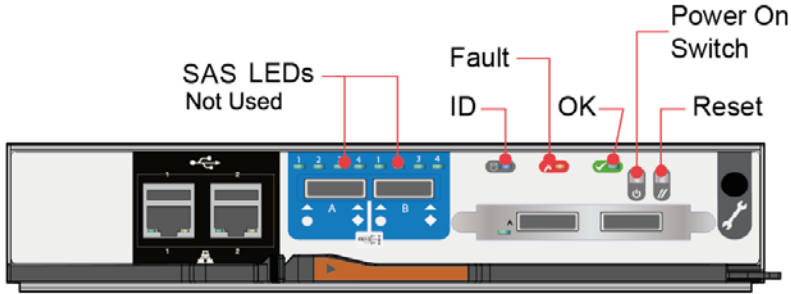

Engine Controller LEDs

LED	Description
ID	Constant green if the Engine Controller is operating correctly.
Fault	This LED is not lit when the Engine Controller is operating correctly. the LED is constant amber if the Engine Controller is faulty. To replace the Engine Controller, see “Engine Controller Replacement” on page 166 .
OK Power	Constant green if the Engine Controller is operating correctly. Flashing green indicates an Engine Controller error.
SAS LEDs	SAS connections to the Engine Controller are not supported. Any LED activity is not relevant to the ISIS 2000 operation.

Management Console Error Messages

The following sections suggest actions to perform on selected error messages in the Management Console. For information on all error messages, see the *Avid ISIS Administration Guide*.

Missing Spare Drive Message

The “Missing spare drive” state from the Management Console can be caused by the following reasons:

- A legitimate media drive failure
- Drive was disconnected and reconnected while system was running.
- Attempting to replace a failed drive with a previously used drive.

A media drive failure and disconnecting a media drive causes the system to “fail” the drive and start rebuilding with the hot spare. For details on how to replace media drives, see [“Media Drive Replacement” on page 159](#).

To recover from a failed media drive:

1. Physically remove the failed drive (the drawer and drive Fault LED should be lit).
2. Insert the replacement drive.
3. After a short time, the Storage Manager makes the new drive a spare and clears the state (this could take a few minutes).

To recover from a removed/reconnected media drive or a previously used media drive (from another ISIS 2000 Engine was added as a replacement spare):

1. Open Storage Manager Agent.
2. Click Advanced > Disk Tools > Clear Foreign Config.
3. Enter password and click Clear.
4. After a short time, the Storage Manager makes the problematic disk spare and clears the state (this could take a few minutes)

Invalid Drive — Foreign Disk Message

The “Invalid drive - Foreign disk” status in the Management Console denotes that a physical disk is connected in the Engine, but is not either raw or already part of the existing ISIS configuration. This can happen if a disk has an existing file system or was moved from a running system.

To recover from a removed/reconnected media drive or a previously used media drive (from another ISIS 2000 Engine was added as a replacement spare):

1. Open Storage Manager Agent.
2. Click Advanced > Disk Tools > Clear Foreign Config.
3. Enter password and click Clear.
4. After a short time, the Storage Manager should make the problematic disk spare and clears the state (this could take a few minutes)

Disk Performance Degraded Message

The “Disk performance degraded” status can appear for the following reasons:

- Failed physical disk
- Disks reporting too many long I/Os

For a failed disk, the status typically includes “Missing spare drive,” see [“Missing Spare Drive Message” on page 152](#).

To check for poorly performing disks:

1. Open Storage Manager Agent.
2. Click Statistics > Storage Manager > Disk.

Invalid Number of Disks Message

The “Invalid number of disks” status is an indication that the Storage Manager does not see the correct number of RAID arrays (or disks) for the Storage Manager.

To check the RAID configuration:

1. Open Storage Manager Agent.
2. Click Advanced > RAID Diagnostics.
 - ▶ Click Verify RAID Config.
 - ▶ Click Show RAID Config.
 - ▶ Click Show RAID Status.

Depending on your ISIS 2000 Engine configuration you should have four or eight arrays.

If you do not have the correct number of arrays, make sure all drives are there (and in the correct slots for the ISIS 2000 configuration) You might need to do use the “Delete and Recreate” command in the Advanced tab to recover once all drives are available.

No RAID Arrays Exist

The RAID sets should be configured on install. The reason this might not have happened is that some or all of the drives were not present at install time.

To manually build the RAID sets:

1. Open Storage Manager Agent.
2. Click Advanced > Destructive RAID Tools > Delete and Recreate.
3. Enter password and click Recreate.

The RAID sets start rebuilding and restarts the Storage Manager.

Not All RAID Arrays Are Active

In most cases the array attempted to start but could not and is left in an “inactive” state. This typically happens if multiple drives are not available at startup or all disconnect at the same time. In most cases restarting the offending arrays fixes this problem. To recovery from this is to use the “Repair Config” button.

To repair the configuration:

1. Open Storage Manager Agent.
2. Click Advanced > RAID Tools > Repair Config.
3. Enter password and click Repair.

The RAID sets start rebuilding and restarts the Storage Manager.

Thermal Sensors



Thermal sensors throughout the Engine and its components monitor the thermal health of the storage system. Exceeding the limits of critical values cause the over-temperature alarm to occur.

Thermal Monitoring and Control

The Engine uses extensive thermal monitoring and takes a number of actions to ensure component temperatures are kept low and also to minimize acoustic noise. Air flow is from the front to the rear of the Engine.

The following table provides a description of the ISIS 2000 Engine thermal alarm.

Engine Thermal Monitoring and Control

Symptom	Cause	Action
<p>If the ambient air is below 25 °C and the fans increase in speed. Any restriction of airflow can cause the internal temperature to rise.</p> <p> <i>This is not a fault condition.</i></p>	<p>The first stage in the thermal control process is for the fans to automatically increase in speed when a thermal threshold is reached. This can be caused by higher ambient temperatures in the local environment and be perfectly normal.</p> <p> <i>This threshold changes according to the number of drives and power supplies fitted.</i></p>	<ul style="list-style-type: none"> • Check the installation for any airflow restrictions at either the front or rear of the Engine. A minimum gap of 25 mm at the front and 50 mm at the rear is recommended. • Check for dust build-up. Clean as appropriate. • Check for excessive re-circulation of heated air from rear to the front. Use of the Engine in a fully enclosed rack is not recommended. • Check that all blank modules are in place. • Reduce the ambient temperature.

Thermal Alarm

The following table provides a description of the ISIS 2000 Engine thermal alarm.

The ISIS 2000 Thermal Audio Alarm

Symptom	Cause	Action
<p>Front panel module fault LED is amber.</p> <p>Fan fail LED is lit on one or more cooling modules.</p>	<p>The internal temperature has exceeded a pre-set threshold.</p>	<ul style="list-style-type: none"> • Check that the local ambient environment temperature is within specification (see “Environment” on page 190). • Check the installation for any airflow restrictions at either the front or rear of the Engine. A minimum gap of 25 mm at the front and 50 mm at the rear is recommended. • Check for dust build-up. Clean as appropriate. • Check for excessive re-circulation of heated air from rear to the front. Use of the Engine in a fully enclosed rack is not recommended. • If possible shutdown the Engine and investigate the problem.

11 Adding and Replacing Hardware

This chapter provides procedures for adding and replacing components in your Avid ISIS. Avid ISIS hardware additions and replacements are to be performed by Avid ISIS Avid Certified Support Representatives (ACSR).

Do *not* add any hardware if there are any issues with the system. Correct all problems before adding new hardware and making changes to the system, perform quick checks to verify that the system is in good working order, see [“Health Check” on page 123](#).

The following components can be hot-swapped by the user in the field without removing the Engine from its rack:

- [Media Drive Replacement](#)
- [Cooling Module Replacement](#)
- [Power Supply Replacement](#)
- [Replacing an Internal System Director Drive](#)



Do not lift the Engine by the handles on the power supply units, cooling modules or Engine Controllers – they are not designed to take the weight.



Always have available a replacement or blank module before removing the old module. When you replace a module, you must never leave a bay empty or drive drawer open more than 10 minutes.



It is recommended that you use a suitable anti-static wrist or ankle strap and observe all conventional ESD precautions when handling plug-in modules and components.

Continuous Operation During Replacement

Your hardware or software Engine management application determines the capability of replacing a failed disk without loss of access to any file system on the Engine. Engine access and use during this period is uninterrupted.

If an Engine contains two power supplies, one of them can maintain power to the system while the other is replaced.

Media Drive Drawer

This section describes how to open the media drive drawer and replace a media drive. The procedure is the same for both drawer 1 and drawer 2.

To open a drive drawer:

1. Make sure the anti-tamper locks are not engaged. The red arrows on the locks will point inwards if the locks are disengaged. Unlock them if necessary by rotating them counterclockwise using a screwdriver with a torx T20 bit.



2. Push the drawer latches inward and hold them.
3. Pull the drawer all the way out until it locks open.

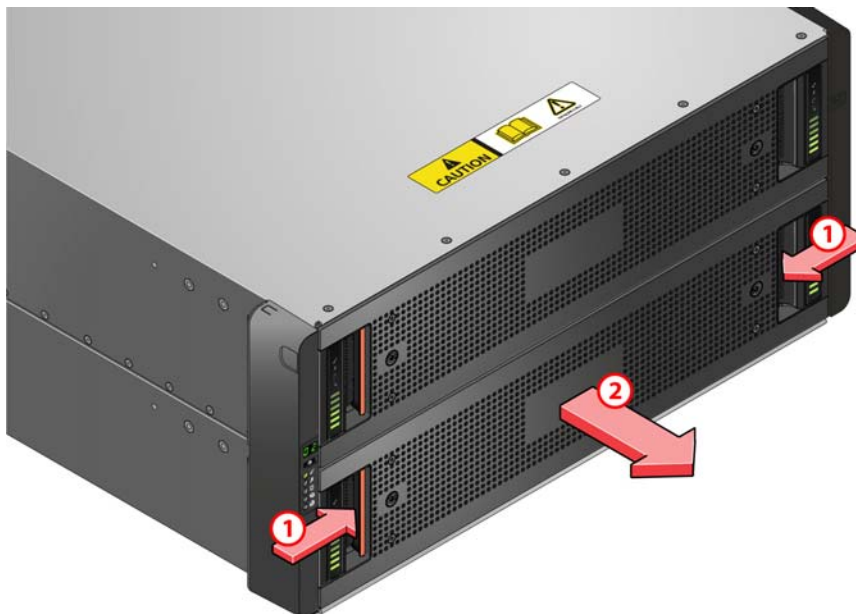

To close a drive drawer:

1. Pull and hold both of the white latches on the sides of the drawer.
2. Push the drawer in slightly.
3. Release the white latches.
4. Push the drawer all the way back into the Engine, making sure it clicks in place.

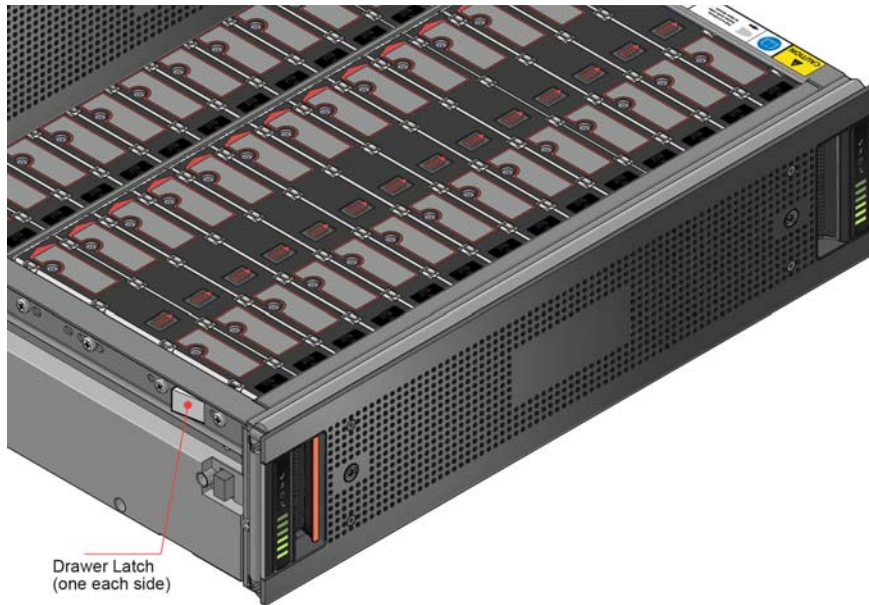

Media Drive Replacement

When a RAID media drive fails, the ISIS automatically replaces the failed drive in the RAID set with the hot spare. You can identify the failed drive by locating the drawer on the front that has a drive fault LED lit, see [“Engine Control Panel” on page 19](#). When you have a failed drive, the Status section in the Management Console displays amber and states the drive set is rebuilding with the percentage of how much of the RAID set rebuild has completed. You can remove a failed media drive whenever the LED has indicated that the drive has failed. The rebuild process does not need to be completed before the failed drive can be removed. The status remains yellow until the rebuild is finished and a new hot spare has been inserted. When the new hot spare is inserted, the ISIS 2000 automatically makes the raw drive into a spare.



When replacing a failed media drive in the ISIS 2000-120, you must install the replacement drive in the slot where you removed the failed drive. Do not install replacement drives in the slots identified as “Not Used” in the illustrations shown in [“ISIS 2000-120 Media Drive](#)

Configuration” on page 26.

You do not need to stop the System Director to replace a single drive.

As long as you have a spare drive in the Engine the RAID controller automatically starts repairing a RAID group using the spare when:

- The RAID controller identifies a drive has failed.
- A media drive has been physically pulled from the Engine (without being identified using one of the two previous conditions).

Removing a Media Drive

The procedure for replacing media drives is the same for both drawer 1 and drawer 2.

To remove a media drive:

1. Make sure the anti-tamper locks are not engaged. The red arrows on the locks will point inwards if the locks are disengaged. Unlock them if necessary by rotating them counterclockwise using a screwdriver with a torx T20 bit.
2. Open the appropriate drawer, see [“Media Drive Drawer” on page 158](#).
3. Locate the drive to be replaced, by looking for the amber LED on the drive that indicates a fault see [“Media Drive LED” on page 150](#).

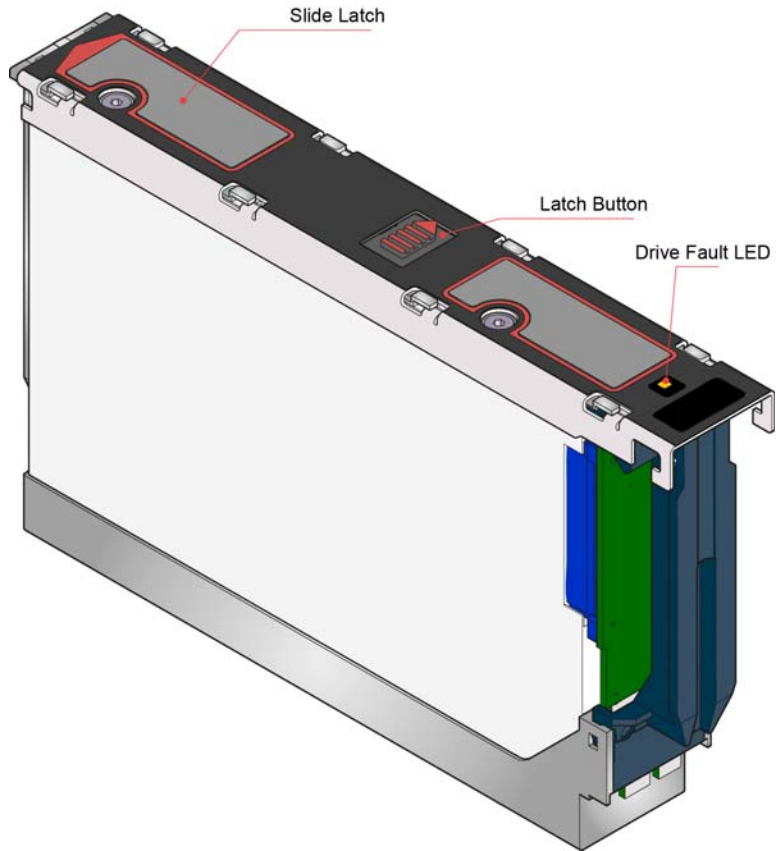

4. Push the drive carrier latch in the direction shown in the following illustration to unlock the drive.

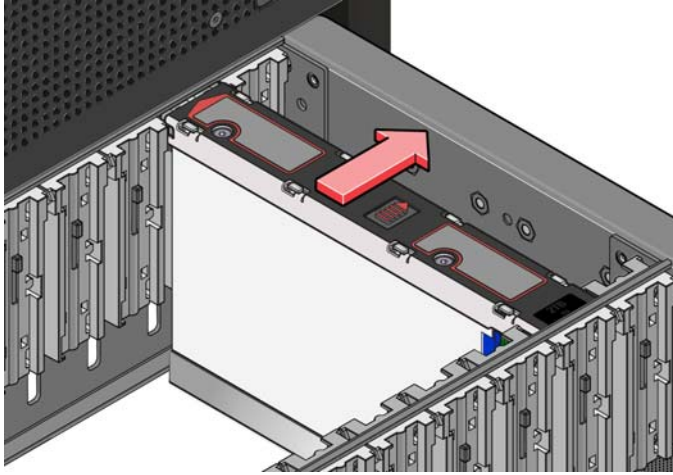

5. Pull the drive upwards and out of the drawer.



If you are not going to replace the drive immediately, close the drawer so that correct airflow and cooling are maintained in the Engine.

Replacing a Media Drive

When the new media drive is inserted, the ISIS 2000 automatically makes the new drive into a hot spare.

To insert a media drive:

1. If the appropriate drawer is not already open, open it using the instructions in section see [“Media Drive Drawer” on page 158](#).
2. Lower the Media Drive into the slot, with the drive capacity label facing towards you.
3. Push the media drive downwards and hold it down while sliding the drive carrier plate in the direction shown in the following figure. This locks the drive in place.

Make sure the drive is securely locked into place before closing the drawer.

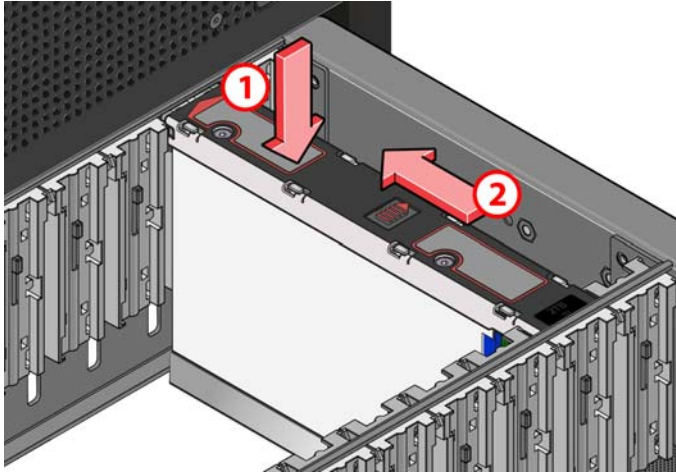

4. Close the drawer see [“Media Drive Drawer”](#) on page 158.

The new drive now becomes the hot spare.

Forcing a Foreign Drive to Become a Spare

If the new media drive is not automatically imported as a hot spare and the System Status Panel in the Management Console reports a foreign disk or no spare, use the following steps to clear the foreign configuration and create a spare disk. This function requires the Administrator password.

To clear a drive that displays as a foreign drive:

1. Open the Storage Manager Agent, do one of the following. For more information see the *Avid ISIS Administration Guide*.
 - ▶ From the Storage Managers tool, select an IP address from the IP Addresses panel of the Details panel, and click the Info button.
 - ▶ From the Storage Elements tool, select an IP address from the IP Addresses panel of the Details panel, and click the Info button.
2. Type the Administrator password into the password field.



The default Agent Administrator password is “se-admin.”

3. Click the Advanced tab.



Resetting a disk is a destructive operation which permanently delete all data currently stored on the disk.

4. Select Clear Foreign Config from the left pane.

5. Type the Administrator password into the password field right pane and click Clear.

Cooling Module Replacement

This section describes how to replace the cooling module.



You should have a replacement module to insert before removing a module. When the Engine power is left on, a new cooling module should be inserted within two minutes of the removal of the defective cooling module.

To remove a cooling module:

1. Identify the cooling module to be removed. If the module has failed, the fan fault LED will be lit amber.

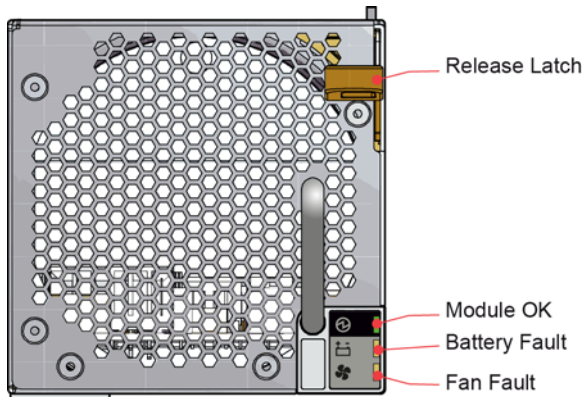

2. Push down and hold the red release latch (1) and pull the module out by its handle (2).

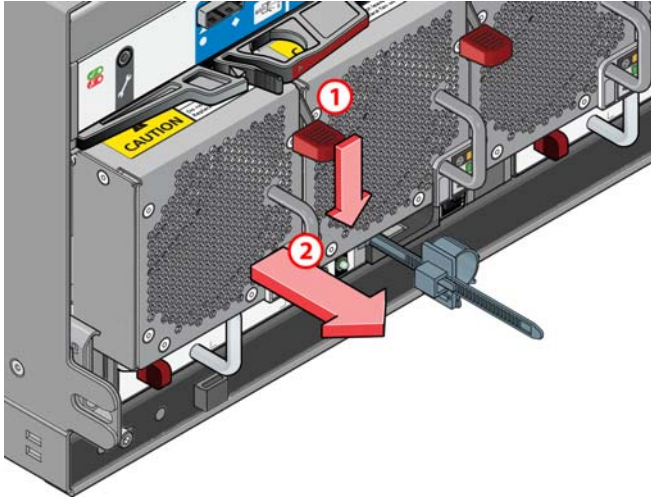

To insert a cooling module:

1. Position the cooling module so that the red release latch and handle are on the right-hand side.
2. Slide the cooling module into its slot until the latch clicks in place. The Engine will automatically detect and make use of the new unit.

Power Supply Replacement

This section describes how to replace the power supply.



You should have a replacement module to insert before removing a module. When the Engine power is left on, a new power supply should be inserted within two minutes of the removal of the defective power supply.



Do not lift the Engine by the handles on the power supply units, cooling modules or Engine Controllers – they are not designed to take the weight.

To remove a power supply:

1. Identify the power supply to be removed. If the module has failed, the fan fault LED will be lit amber.
2. Push the red release latch to the right and hold it (1), then pull the module out by its handle (2).

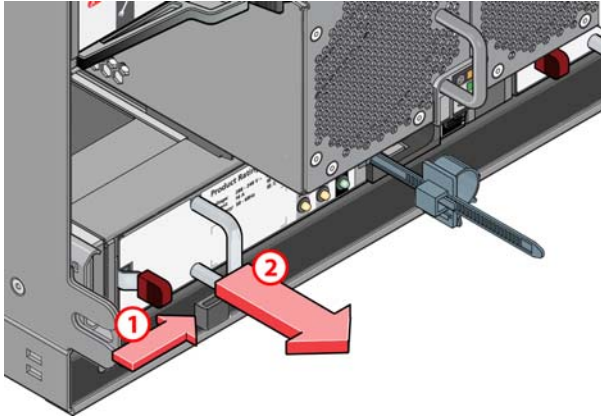



To insert a power supply:

1. Position the power supply so that the red release latch and handle are on the left-hand side.
2. Slide the power supply into its slot until the latch clicks in place. The Engine will automatically detect the new unit.

Engine Controller Replacement

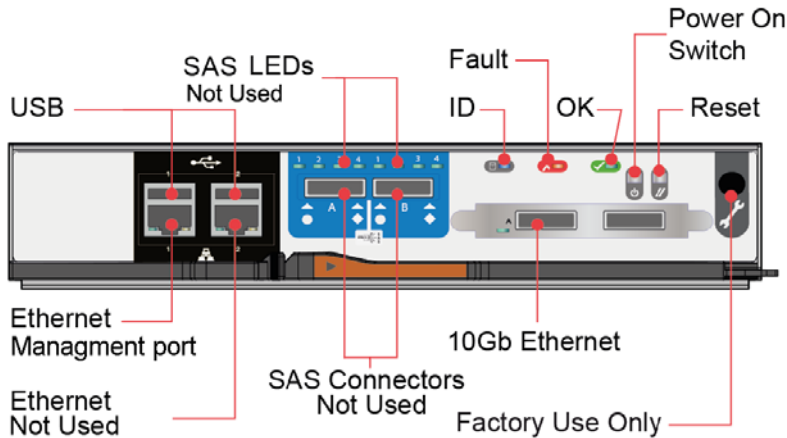
This section describes how to replace the Engine Controller. If the Engine Controller has failed, the fault LED will be lit red.



 *You should have a replacement module to insert before removing a module. When the Engine power is left on, a new Engine Controller should be inserted within two minutes of the removal of the defective Engine Controller.*



The Engine Controller module is only supported in the left slot (as seen from the rear of the Engine). Do not install the Engine Controller in the right slot, the software will not run.

To remove a Engine Controller:

1. If the Engine Controller is still accessible through the ISIS Management Console Agent Page, log into the ISIS Management Console Storage Manager Agent Page > System tab > Network and note the hostname, IP address, and other important network details.



The default Agent Administrator password is “se-admin.”

If the Engine Controller is not accessible through the ISIS interface, continue with step 2 and skip to 4; removing the cables and pulling out the Engine controller.

Leave the ISIS Management Console Storage Manager Agent Page open, you need it access the Agent Page in step 3.

2. Stop the System Director service using the ISIS Control Panel or Launch Pad.
Once the System Director service is stopped, you can only access the Agent page in step 3 using the Engine IP address you have just noted.
3. Shutdown the Engine Controller using the Storage Manager Agent Web page via the Engine IP address: `https://IP_address:5015`.
 - a. Type the Administrator password into the password field.
The ISIS 2000 Storage Manager Agent page appears.

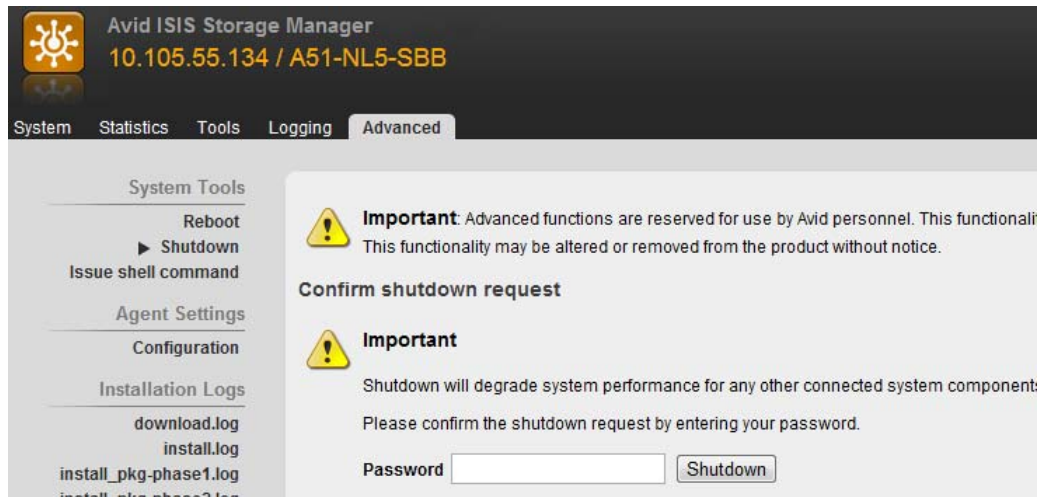

- b. Click the Advanced tab.
- c. Select Shutdown from the left pane.

- d. Type the Administrator password into the password field and click Shutdown.
- e. Allow 1 minute for the buffers to clear and turn off the power to the Engine (two power supply switches).
4. Make note of the locations of all Ethernet cables (1-Gb, 10-Gb) and disconnect them from the failed Engine Controller.
5. Pinch the latch on the Engine Controller and pull the handle towards you (1).
This will lever the controller out of its connector on the midplane.
6. Pull the Engine Controller out of the Engine (2).

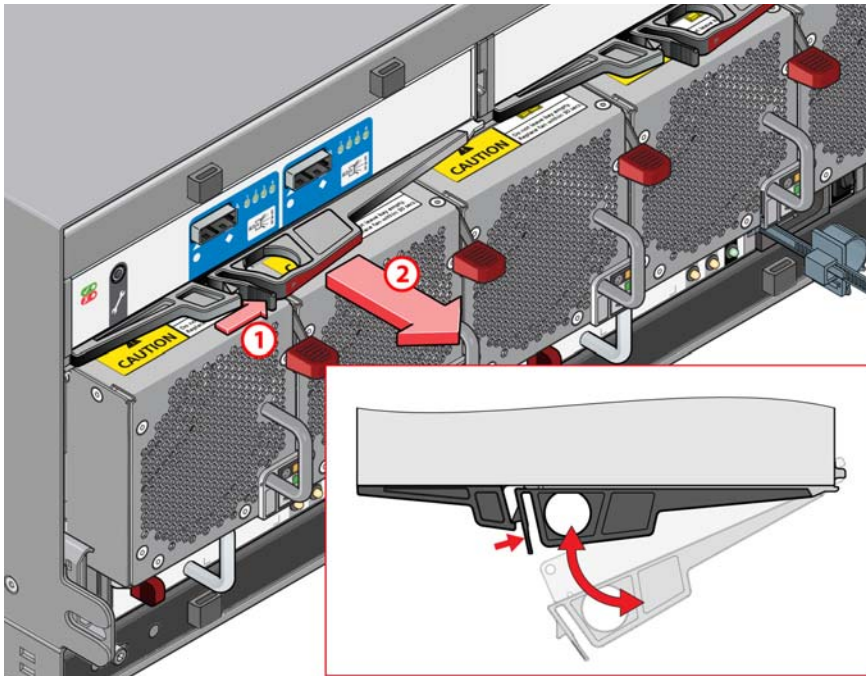

7. Install and configure the new Engine Controller as described in the following procedure.

To insert an Engine Controller:

1. Position the Engine Controller so that the release latch is at the bottom.
2. Open the release latch and rotate it to its most open position.
3. Slide the Engine Controller into its slot until it will go no further.
4. Close the latch until it clicks in place.

This will lever the Engine Controller into its connector on the midplane. The Engine automatically detects the new unit.

5. Reconnect the Ethernet cables to the new Engine Controller (if necessary, refer to the notes you made before removing the cables).
6. Using a System Director (or computer running a Windows operating system), connect an Ethernet cable between the 1 Gb network port of the System Director and the management port of the Engine Controller (left 1 Gb Ethernet port).
7. Open a browser and navigate to the ISIS 2000 Storage Manager Agent Web page via the following address: `https://192.168.0.10:5015`.
8. You are asked for the default password. Type `se-admin`.
9. Click Network in the left pane of the System tab.
The ISIS 2000 Storage Manager Agent page appears.

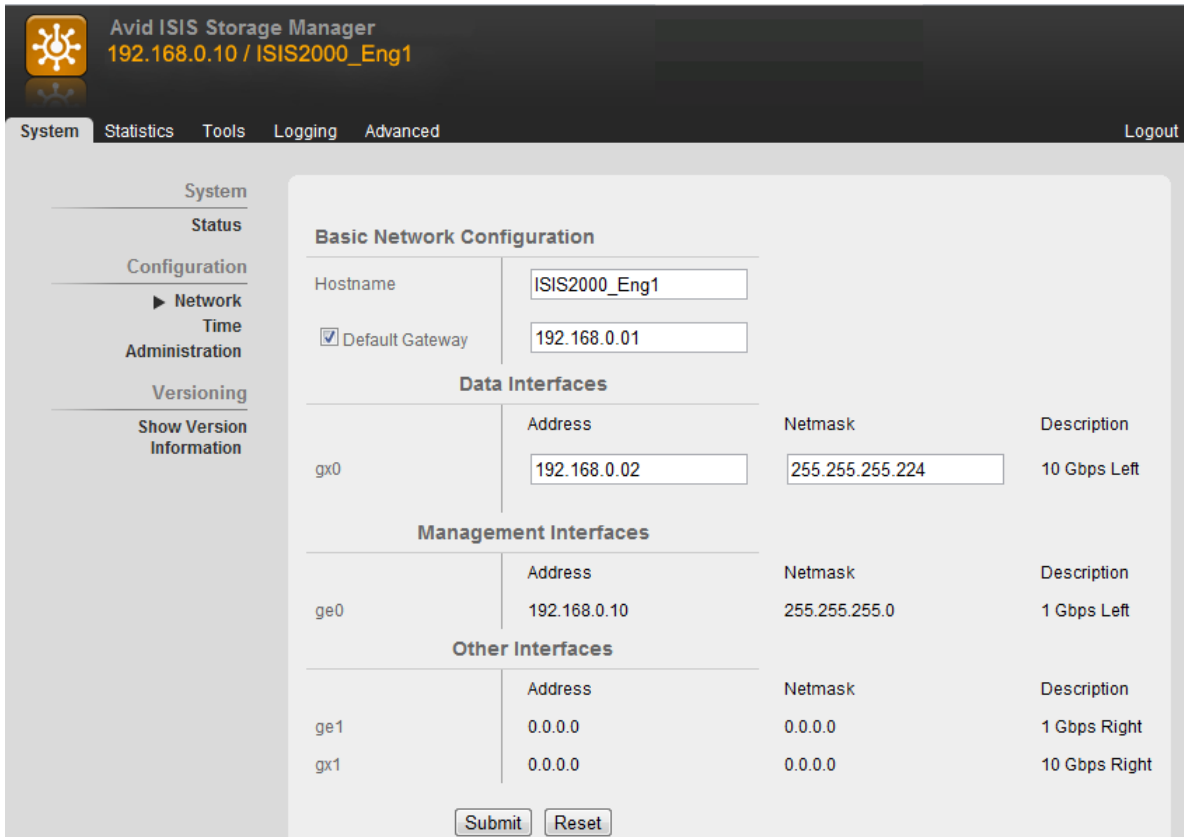

10. Type the following into the Basic Network Configuration window:
 - Type the Hostname you want for you Engine Controller.

- (Option) If using a Gateway, select the Default Gateway checkbox and enter the IP addresses of your default gateway.
 - Enter the IP addresses of the Engine Controller and Netmask in the Data Interfaces text boxes.
11. Upgrade to the ISIS Storage Manager to match the version on your System Director, see [“Installing Software on the Engine” on page 73](#).
 12. Verify that the Storage Manager is online with a green icon with no Status displayed in the Management Console > Storage Manager page.



If any Status errors are listed, call Avid Customer Support.

13. Verify that the Storage Element is online with a green icon with no Status displayed in the Management Console > Storage Element page.
14. Verify that media is available to the ISIS clients.

Engine Replacement

Use the following procedure when replacing an ISIS Engine. For purposes of this procedure, the Engine to be replaced is referred to as “failed Engine” and the replacement Engine as “new Engine.”

To replace an ISIS Engine:

1. If the Engine Controller is still accessible through the ISIS Management Console Agent Page, log into the ISIS Management Console Storage Manager Agent Page > System tab > Network and note the hostname, IP address, and other important network details.



The default Agent Administrator password is “se-admin.”

If the Engine Controller is not accessible through the ISIS interface, continue with step 2 and skip to 4; removing the cables and pulling out the Engine controller.

Leave the ISIS Management Console Storage Manager Agent Page open, you need it access the Agent Page in step 3.

2. Stop the System Director service using the ISIS Control Panel or Launch Pad.

Once the System Director service is stopped, you can only access the Agent page in step 3 using the Engine IP address you have just noted.
3. Shutdown the Engine Controller using the Storage Manager Agent Web page via the Engine IP address: `https://IP_address:5015`.
 - a. Type the Administrator password into the password field.

The ISIS 2000 Storage Manager Agent page appears.

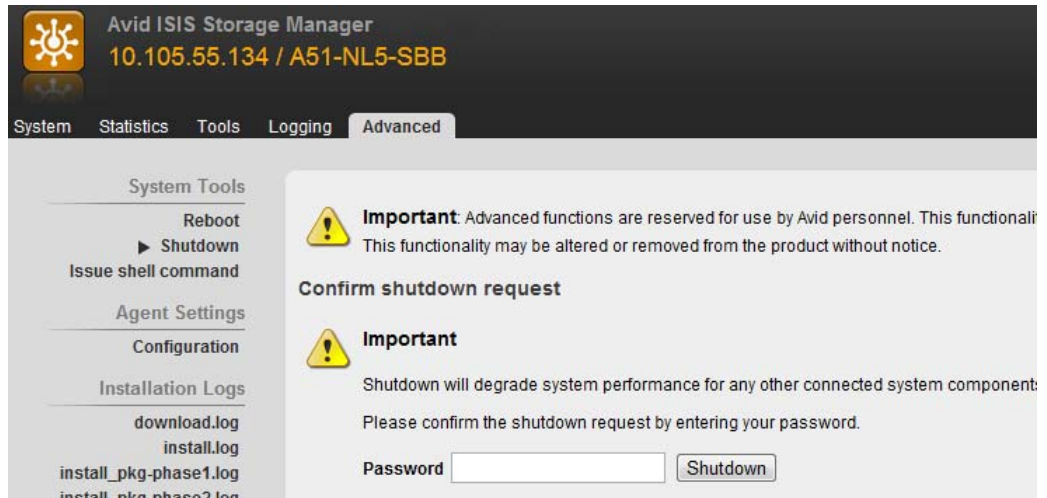

- b. Click the Advanced tab.
 - c. Select Shutdown from the left pane.
 - d. Type the Administrator password into the password field and click Shutdown.
 - e. Allow 1 minute for the buffers to clear and turn off the power to the Engine (two power supply switches).
4. Make note of the locations of all Ethernet cables (1-Gb, 10-Gb) and disconnect them from the failed Engine Controller.
 5. Switch both power switches to off position on the rear of the failed ISIS 2000 Engine.
 6. Disconnect all 1-Gb, 10-Gb (optical), and power cables from the failed Engine.
 7. Carefully remove all the media drives from both drawers and put them in a safe place (see [“Removing a Media Drive”](#) on page 160).



As a precaution, Avid recommends you record the slot location of the removed drives and reinstall them in the same slots.

8. Carefully remove the Engine Controller from the failed Engine and put it in a safe place (see [“Engine Controller Replacement”](#) on page 166).
9. Carefully remove both power supplies from the failed Engine and put them in a safe place (see [“Power Supply Replacement”](#) on page 165).
10. Carefully remove the five cooling modules from the failed Engine and put them in a safe place (see [“Cooling Module Replacement”](#) on page 164).
11. Remove the failed Engine from the rack.
12. Install the new Engine into the rack (without the drives, modules, and power supplies).

13. Carefully reinsert all media drives into the same drawers (and slots if possible) they were removed from.
14. Carefully reinsert the two power supplies.
15. Carefully reinsert the five cooling modules.
16. Carefully reinsert the Engine Controller.



The Engine Controller module is only supported in the left slot (as seen from the rear of the Engine). Do not install the Engine Controller in the right slot, the software will not run.



When re-using the original Engine Controller that was in this ISIS environment, you do not need to reconfigure Engine Controller. The IP address and ISIS software should be recognized by the ISIS System Director and environment.

17. Reconnect all 1-Gb, 10-Gb (optical), and power cables to the new Engine.
18. Power-on the new Engine.

Give the new Engine at least 2 minutes to initialize.



If any of the LEDs indicate an error, call Avid Customer Support.

19. Verify that the Storage Manager is online with a green icon with no Status displayed in the Management Console > Storage Manager page.



If any Status errors are listed, call Avid Customer Support.

20. Verify that the Storage Element is online with a green icon with no Status displayed in the Management Console > Storage Element page.
21. Verify that media is available to the ISIS clients.

Replacing an Internal System Director Drive

There are two system drives installed in the Avid ISIS System Directors. The two drives are mirrored and accessible from the front of the System Director. If you have a failure on either one of the two system drives you can pull the failed drive out of the System Director and install a replacement without turning off the Avid ISIS System Director. The Avid ISIS continues to run properly if one of the two system drives are removed.

As soon as you install a replacement system drive into the vacant system drive slot, the system begins the process of creating a mirror of the original drive on the new drive. All Avid ISIS operations continue to run uninterrupted.

To replace the System Director drive:

1. Remove the failed drive from the front of the System Director by releasing the drive latch on the front of the drive and pulling the drive from the chassis.
2. Insert the new drive completely into the open drive slot and close the drive latch.

The new drive initiates and completes the repair with no other intervention.

Saving ISIS Metadata

This procedure describes how to save the metadata stored on the system drives in the ISIS System Director. This procedure would typically only be needed in the event of a hardware replacement where both system drives or the System Director server itself will be replaced in an active ISIS installation.

All the metadata for all the media drives in the Engine are saved in the System Director. The Engines do not store any metadata.

To save the System Director metadata:

1. Stop the System Director service using the ISIS Control Panel.



The System Director is constantly writing metadata. Metadata files are always open and locked, so the best way to copy the metadata files is to stop the System Director service so the files are closed.

2. Copy the Partition0 and Partition1 files from the following location on the System Director:

```
D:\Program Files\Avid\ISIS System Director\
```



There is also a PartitionDump.bin file. This file is also helpful when identifying the data on the media drives. If possible, include this file with the two Partition metadata files.

The following are a couple suggested ways of saving the Partition0 and Partition1 PartitionDump.bin files.

- Use a USB flash drive that has the capacity for the Partitionx files (4 GB recommended).
 - Create a network share on a client system on the network and copy the Partitionx files to that shared folder.
3. Verify that you have the current copy of the Metadata by comparing the date in the Metadata tab of the ISIS control Panel.
 4. Start the System Director service using the ISIS Control Panel.

Replacing System Drives in the System Director

When moving the systems drives from one System Director to another, the order in which you replace these drives in the new System Director should not matter. Although it would be good practice to mark the system drives as to the left and right drives and replace them back in the same order in the new System Director.

To replace a single failed system drive:

1. Open the Intel Rapid Storage Technology application:
Start > Programs > Intel > Intel Rapid Storage Technology
2. Click the Manage button in the application.

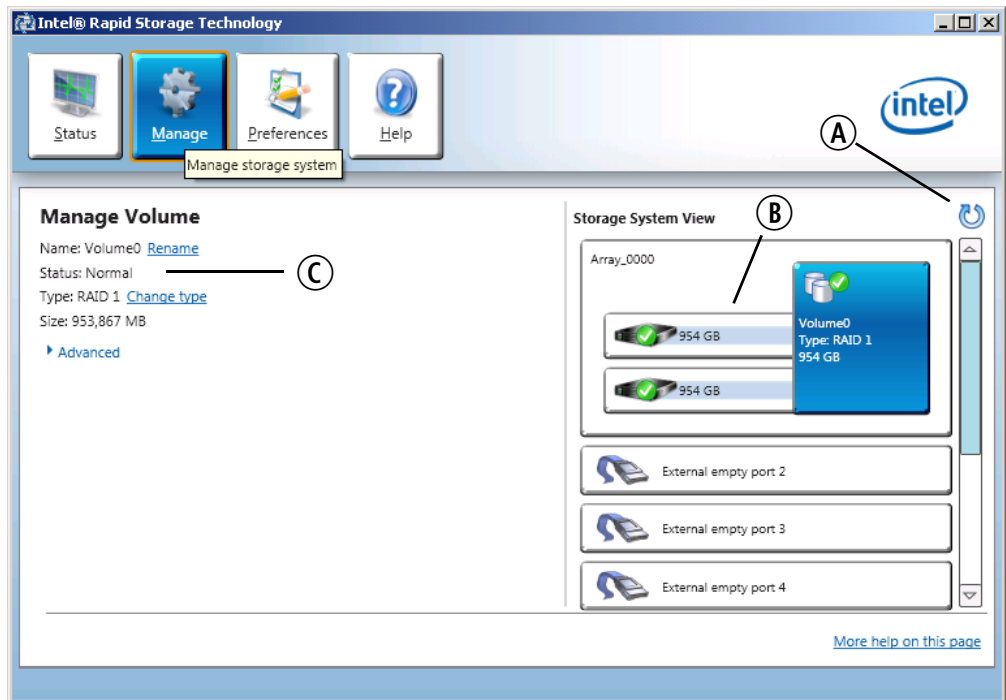

- A. Run hardware scan button
- B. Disk icons
- C. Status line

3. Pull the failed drive out of the System Director and install a replacement without turning off the System Director.

Once the drive is installed, use the Intel Rapid Storage Technology application to initiate the rebuild operation as described in the following steps.

4. Click the Run hardware scan button (identified as A in the above illustration) to refresh the RAID data to the current state.
5. The volume icon has two smaller disk icons attached to it - one for each disk of the RAID set. Perform one of the following operations:
 - If the disk has previously been part of the RAID set, the disk appears as an icon attached to the Volume 0 icon and the application immediately begins the rebuild. You can monitor the status, in this case the status line displays “Rebuilding x% complete.”
 - If the replacement disk has never been part of this RAID set, the disk icons display a list of available disks. The Status line will display “Degraded,” and the words “rebuild to another disk” is underlined. Click on the underlined text.
6. A window opens that offers a choice of drives to add to the array. Click on the one drive that needs to be added to the RAID set. The rebuild operation begins immediately.

You can use the Status line to monitor the status of the rebuild. The top of the screen says Manage Volume, and the status line says “Rebuilding x% complete.”



You can perform other work while the rebuild completes.

To replace both system drives:

1. If both system drives fail, shut down the system, and unplug the power cords.
2. Remove both system drives.
3. Install new system drives into the two system drive slots.
4. Replace the power cords and restart the system.
5. Enter the Intel RAID BIOS by pressing CTRL+I when the text MATRIX RAID BIOS appears on the screen.
6. Choose Create the new RAID set. This will create the system drive mirror.
 - a. Change RAID type from RAID 0 Stripe to RAID 1 Mirror (volume name and capacity can be left at the defaults).
 - b. Select Create RAID, answer yes to the “are you sure” messages.
 - c. The RAID set (Volume 0) should be shown as online with the two physical disks (port0 and 1) listed below as array members.
 - d. Exit the RAID BIOS and allow the system to restart.
7. Turn on your System Director and reimage your system drives which includes loading the Windows operating system, see [“Using the Product Recovery USB for 64-bit System Directors” on page 184.](#)
8. Use the same IP addresses previously assigned.
9. Install the Avid ISIS software on the new system drives, see [“Software Installation” on page 64.](#) Remember to select the appropriate option between the System Director software.

10. Stop the System Director service using the ISIS Control Panel.
11. (Option) If this is your System Director copy your last saved Partition0 and Partition1 files to the following location on the System Director: Include the PartitionDump.bin file if you saved them too.
 D:\Program Files\Avid\ISIS System Director\
12. Start the Management Console and verify that all workspaces are listed. If not, call customer support before continuing.

Moving the Metadata to a New System Director

Use the following procedure if you need to move the Metadata from one Avid ISIS System Director to another Avid ISIS System Director.

To move the System Director Metadata:

1. Stop the old System Director service using the ISIS Control Panel.
2. Copy the Partition0 and Partition1 files from the following location on the System Director:

D:\Program Files\Avid\ISIS System Director\



There is also a PartitionDump.bin file. This file is also helpful when identifying the data on the media drives. If possible, include this file with the two Partition metadata files.

The following are a couple suggested ways of moving the Partition files.

- Use a USB flash drive that has the capacity to move the Partition files.
 - Create a network share on a client system on the network and copy the Partition files to that shared folder. From the new System Director copy the Partition files into the temporary folder.
3. Verify that you have the current copy of the PartitionDump.bin file from the old System Director.
 4. Start the new Avid ISIS 2000 System Director server and load the System Director software.
 5. Stop the new System Director service using the ISIS Control Panel.
 6. Configure the virtual name and IP address on the new System Director to match the old System Director.

Configure the virtual name in the ISIS System Director Control Panel and IP address using the Network Configuration Tool.



It is acceptable to change the IP address scheme of the new System Director. It is not recommended that you change the virtual ISIS name.



If using the same IP addresses as the old System Director, make sure to shut down the old System Director first to prevent an IP conflict.

7. Copy the Partition0 and Partition1 files (and PartitionDump.bin file if copied) into the following location on the new System Director:

```
D:\Program Files\Avid\ISIS System Director\
```

8. Start the new System Director service using the ISIS Control Panel.
9. Verify that the System Director is now running. Start the Management Console and verify that all workspaces are listed. If not, call customer support before continuing.

Network Switch Replacement

If replacing a switch in the ISIS environment, the following are a few suggestions you need to consider before removing the switch.

- Have a backup copy of the switch configuration file.
- Disable any Link Aggregation that might be set in your ISIS 7500 | 7000 environment. This prevents odd network behavior and the inevitable trunking errors.
- Disable any trunking to other switches before removing the switch. Any trunking involved with the switch would be part of the configuration file and would help when reconfiguring the trunk on the new switch.
- You do not have to shutdown the System Director or Engines when replacing a switch, particularly if you have a redundant switch configuration.

To replace a switch you will need a console connection to the switch and a tftp server. The following are high level steps that assumes the failed switch is still capable of making a tftp backup. If the switch is completely dead, the configuration will need to either be restored from a previous backup or manually configured.

To capture the switch configuration file:

1. Copy the startup configuration of the failed switch to the tftp server.
2. Install the replacement switch.
3. Configure a temporary interface on the new switch to connect to the tftp server (best to use a no switchport interface with IP address on same subnet as TFTP server).
4. Copy the backup copy of the old switch startup configuration to the new switch (copy tftp startup-config).
5. Reload the switch configuration and old switch configuration should be restored on the new switch.

The specific commands will be different between Cisco and Force10 but they all should be in the switch configuration guide.

If a TFTP server is not available:

- ▶ Use a console/telnet client such as PUTTY to list the configuration and copy it to a text file, which can then be pasted back into the new switch and save to NVRAM.



The PUTTY scroll back buffer needs to be increased from the default 200 to at least 2000. If you increase it to 50000 and make the screen longer and wider you can capture “show tech-support” output,

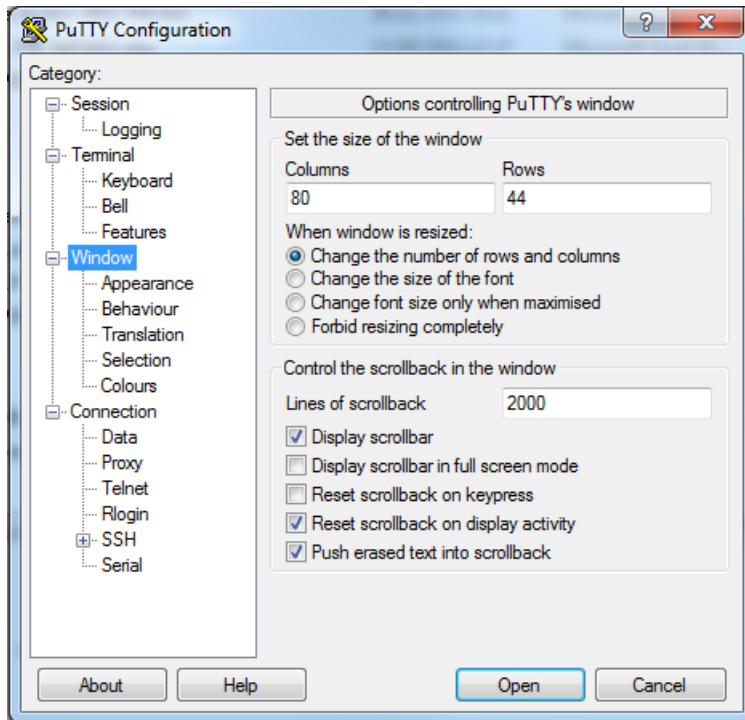

To replace a switch:

1. Disconnect all network cables.
2. Pull out the power cables from the back of the switch.
3. Replace the failed switch with a new switch in the rack.
4. Replace the power cables in the back of the switch to power the switch on.
5. (Option) If you have transceivers in the failed switch, move the working transceivers into the new switch.

- (Option) If you have modified Avid's default Force10 switch configuration, you need to use your terminal emulation program or telnet into switch.

Avid ships Force10 switches configured for ISIS 5500 | 5000 configurations. Any changes you have made to the default configuration would have to be reapplied.

Avid provides sample Cisco switch configurations in the ISIS software kit. Any changes you have made need to be reapplied.

- Reconnect all network cables in the front of the switch.

Adding an ISIS 2000 Engine to Your Infrastructure

Up to five ISIS 2000 Engines are supported in the ISIS 2000 environment, you must be at ISIS v4.5 or later to support multiple Engines. The media drives in each Engine can be bound into one or two Storage Groups or a single Storage Group for multiple Engines. All Engines work off of the System Director.



ISIS 2000 system configurations that include multiple Engines can use either a 1 Gb or 10 Gb connection between the System Director and the switch. If using CIFS clients a 10 Gb connection between the System Director and the switch is required, see “Connecting Network Cables with a 10 Gb System Director Connection” on page 60.

After noting the necessary network and system component information listed in “[Preupgrade Information](#)” on page 134, you are ready to upgrade and add Engines to your ISIS environment. The following is a typical procedure, review the ISIS ReadMe for any specific instructions to the latest release.

To add ISIS 2000 Engines to your ISIS 2000 infrastructure:

- Download the ISIS software kit from the Avid Download Center (www.avid.com/US/support/downloads) to your System Director.
- Upgrade your exiting ISIS 2000 infrastructure to the latest release as described in “[Software Upgrade Process](#)” on page 124.
- Rack Engine in proper position (see “[Rack-Mounting the Equipment](#)” on page 32).
- Install media drives, cooling modules, power supplies, and Engine Controllers (starting with “[Installing the Media Drives](#)” on page 48).
- Apply power to the Engine (see “[Connecting Power to Equipment](#)” on page 52).
- Assign an IP address to the Engine (see “[Setting-Up the Network Address On the Engine](#)” on page 55).

Repeat step 3 to 6 for each addition ISIS 2000 Engine you are adding to the infrastructure.

7. Connect a 10 Gb optical network cable to left 10 Gb port (as seen from the rear of the Engine) on the Engine Controller of the ISIS 2000 Engine. No other 10 Gb port on the Engine has been configured for this connection.

The 10 Gb port on the ISIS 2000 Engine Controller requires an SFP+ transceiver.

The following example shows the physical connections between a System Director, Engine, and a Force10 S4810 switch.

Multiple Engines Network Connections

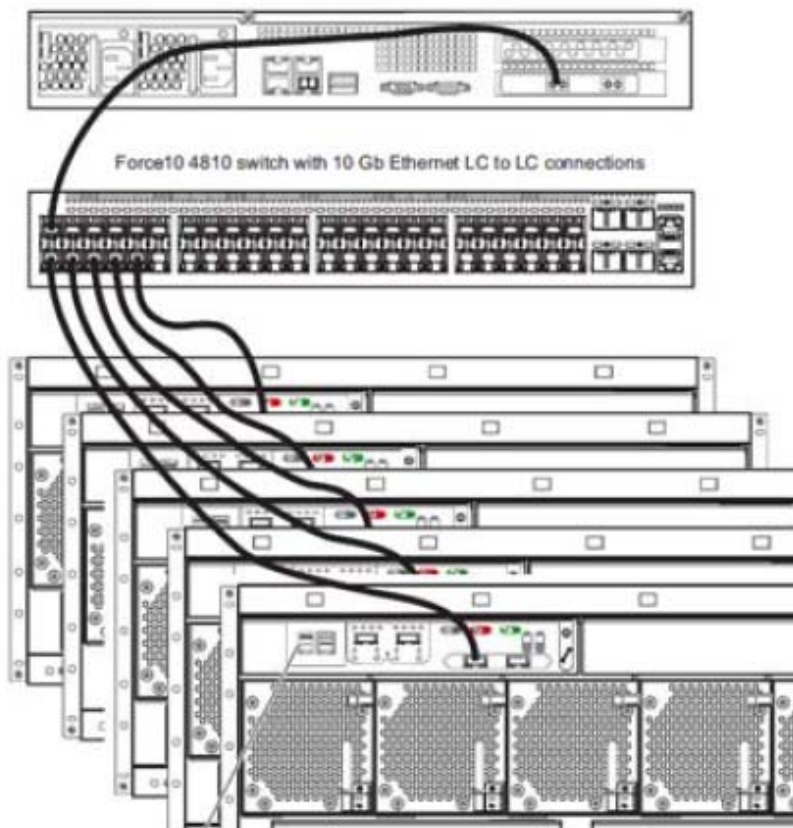

8. Connect the other end of your network cable to the appropriate port on your ISIS 2000 switch.

Depending on the type of switch you have, an X2 or SFP+ transceiver might be needed for the switch port.



The Force10 S4810 switches need SFP+ transceivers with an LC to LC cable connection. The Cisco 4900M switches need an X2 transceiver for the SC type connector with an LC to SC cable connection.

9. Repeat steps 7 and 8 for each ISIS 2000 Engine you are adding (up to five ISIS 2000 Engines are supported).
10. Modify the switch configuration file for the additional Engines. For information on configuring switches, see the *Avid Network and Switch Guide*.
11. Select the new Storage Manager in the list.
12. Click Upgrade.

The Upgrade Storage Managers window opens.

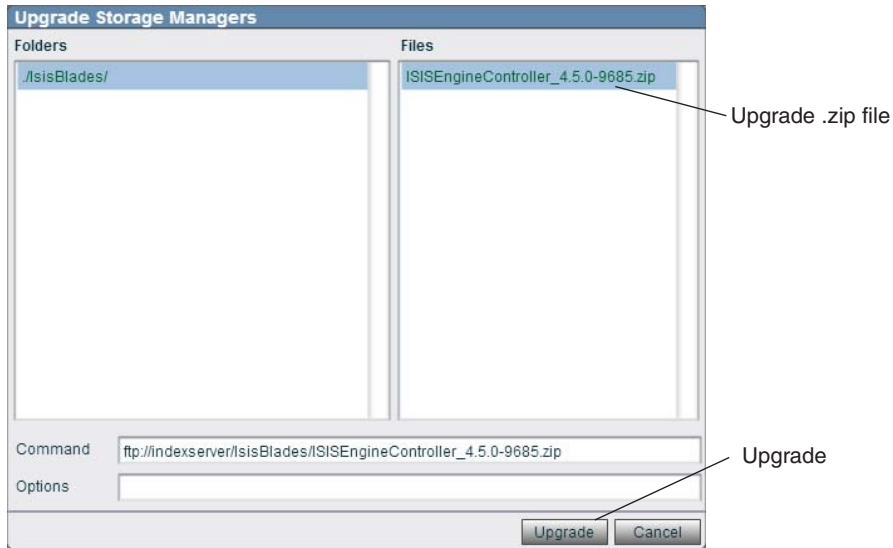

13. Select the .zip file, and click Upgrade.

The Storage Manager installation takes approximately 10 minutes.



Once the Storage Manager upgrade has completed, the software automatically starts building the RAID sets in the ISIS 2000 Engines. Due to the size and number of drives in the Engine, the RAID configuration takes a couple days to complete. Clients can use the ISIS 2000 system during this time although, the more client activity on the Engine, the longer it takes to finish the RAID configuration.

14. Select the new Storage Manager from the list and click Details.



The Status for the upgrade is shown in the Details pane at the right of the window. Click the Refresh button whenever you want the updated upgrade Status. When the Status is empty, the upgrade is complete.

15. Double-click the IP address of the Storage Manager in the Details pane to open ISIS 2000 Storage Manager Agent Web page.
16. You are asked for the password. Type `se-admin`.
The ISIS 2000 Storage Manager Agent page appears.
17. Click Network in the left pane of the System tab.

The screenshot shows the Avid ISIS Storage Manager web interface. The title bar indicates the device is '192.168.0.10 / ISIS2000_Eng1'. The main navigation menu includes System, Statistics, Tools, Logging, and Advanced. The left sidebar shows a tree view with System, Status, Configuration (Network, Time, Administration), and Versioning (Show Version Information). The main content area is titled 'Basic Network Configuration' and contains the following sections:

- Basic Network Configuration:**
 - Hostname:
 - Default Gateway:
- Data Interfaces:**

	Address	Netmask	Description
gx0	<input type="text" value="192.168.0.02"/>	<input type="text" value="255.255.255.224"/>	10 Gbps Left
gx0:1	<input type="text"/>	<input type="text"/>	10 Gbps Left
- Management Interfaces:**

	Address	Netmask	Description
ge0	192.168.0.10	255.255.255.0	1 Gbps Left

At the bottom of the configuration area are 'Submit' and 'Reset' buttons.

18. Enter an IP address in the gx0:1 and Netmask text boxes in the Data Interfaces section.

Starting with the ISIS v4.5 release, the Engine Controller in the ISIS 2000 Engine requires dual IP addresses for ISIS 2000-240 systems. This new IP Address must be in the same subnet as the original IP address.



A second physical cable is not needed, both IP address are handled through the existing 10 Gb connection between Engine Controller and the switch.

19. Click Submit.
 - a. A dialog box appears warning you a Engine reboot is required; click the Reboot button.
 - b. A second dialog box appears, type `se-admin.` in the password box and click Reboot.
20. When the Engine has restarted, open the Storage Managers page in the Management Console.



Do not add any new ISIS 2000 Engines to this existing Storage Group if the ISIS v4.5 upgrade data conversion redistribution has not completed.

21. Bind your new Storage Managers, using the ISIS Management Console > Storage Managers page. For binding instructions, see [“Binding the Storage Managers” on page 78](#).
Repeat steps [11](#) to [21](#) for each new ISIS 2000 Engine you are adding.



After the new Storage Managers are Bound, you can add additional ISIS 2000 Engines and Bind them. Then select all your new Storage Managers and do a single Add redistribution. For Add redistribution instructions see the Avid ISIS Administration Guide.

12 Using the Product Recovery USB for 64-bit System Directors

This section describes the procedures to recover your Avid ISIS system drive by reinstalling Windows Storage Server 2008 R2 and Avid specific additions and changes.

This procedure restores only the Windows operating system and the hardware drivers. It does not restore the Avid ISIS software. The Avid ISIS software must be reinstalled separately, after the operating system recovery is complete. The version number of the image can be found in the C:\IMAGE.TXT file on the root directory of the system drive.



The Avid ISIS ships with a blank 16GB USB drive is used to create a bootable recovery drive. This will be used when the server Operating System needs to be re-imaged. For information on creating see “Creating a Product Recovery USB Flash Drive” on page 184.



After reimaging the server the Administrator password is set to is-admin.

You might need to reinstall the Windows Storage Server 2008 R2 operating system on your Avid ISIS System Director if you are directed to do so by Avid Customer Support. The reinstallation offers you two options:

- Perform a Windows Storage Server 2008 R2 installation to the *entire* system. This replaces all the data from all the available partitions on your system drive. You can perform this operation if you are initializing your system drive.



You lose metadata if you restore all the partitions of the drive.

- Perform this operation to replace only the operating system on your system drive. Typically this removes the *first partition* (C:); the other partitions are not changed.

Creating a Product Recovery USB Flash Drive

Avid highly recommends you copy the image to the 16 GB USB flash drive provided with your Avid ISIS as part of your initial setup. The following procedure describes how to create the product recovery USB flash drive. The product recovery image is included in the C:\Image folder of the system drive.

Once you have created the bootable USB flash drive using the Product Recovery tool, use the USB flash drive to reinstall the operating system image (and associated drivers) to the original state as when it was shipped from Avid.



When you perform a full product recovery of the Avid ISIS system drive using the product recovery USB flash drive, you lose the product recovery image in the C:\Image folder of the system drive.

To create a product recovery USB flash drive:

1. Locate the 16 GB USB flash drive Avid provided with the Avid ISIS and insert it into the front USB port.
2. Click “Create Recovery USB Drive” from the installer splash screen or double-click the AvidRecoveryImageTool.exe file included in the software installer kit from the following location:

\AvidISISUtilities\



A direct link to this file is included in the software install splash screen (Create Recovery USB Drive).

The Avid USB recovery image creator window opens.

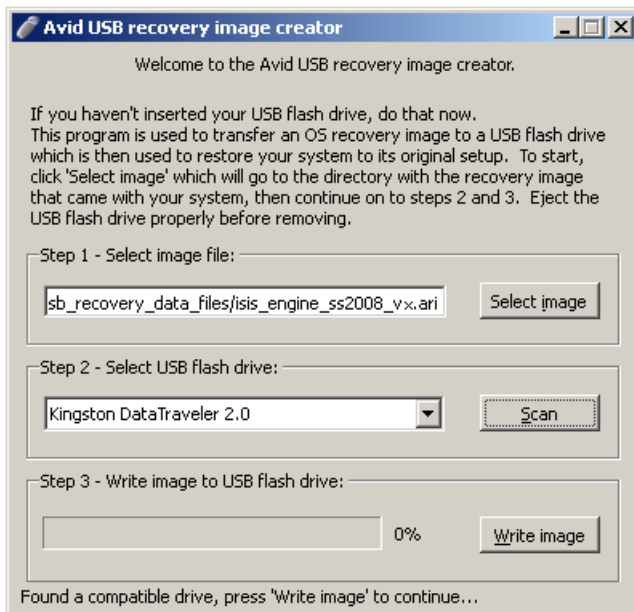

3. Click Select Image to locate the product recovery image from the C:\Image folder of the Avid ISIS system drive (you need to browse to the location of the .ari file).

4. Select the .ari file.

The Scan button becomes active when you select the image file. The “Select USB flash drive” menu lists USB devices that are installed and capable of accepting the image file. If the inserted USB flash drive does not appear in the drop down menu, verify the capacity of the USB flash drive.

5. Click Scan.

6. Select the USB flash drive from the “Select USB flash drive” menu.

The Write image button becomes active when you select the USB flash drive.

7. Click Write image.



Creating the product recovery image on the USB flash drive can take 18 to 45 minutes depending on the capabilities of the USB flash drive.

8. Click OK to acknowledge the warning about losing all previous data on the USB flash drive.

The Write image button becomes a Cancel button when the image is being created. If you cancel the write image process, the process starts over from the beginning on the next undertaking.

9. Click Ok when process is completed.

10. The USB flash drive appears in the taskbar as an icon. Remove the USB flash drive as follows:

- a. Double-click the USB icon in the taskbar. A pop-up menu appears with a list of attached USB devices.
- a. Select the USB flash drive with the product recovery image.
- b. Click Stop.
- c. Click OK to remove the selected USB device.
- d. Remove the USB flash drive from the Avid ISIS.

Reinstalling the Windows Storage Server 2008 R2 Operating System

To reinstall the Windows Storage Server 2008 R2 operating system from the Avid Product Recovery flash drive:

1. Make sure all clients stop any activity and unmount their workspaces.
2. All clients need to exit Client Manager.
3. Locate the Product Recovery Image USB flash drive with the Avid ISIS image.

4. Use the System Director Control Panel to stop the System Director.
5. Insert USB flash drive into the USB port in the system.



You must enter the BIOS with USB flash drive plugged-in to set correct drive boot order.

6. Select Start > Shut Down.
The Shut Down Windows dialog box opens.
7. Select Restart, and click OK.
The Windows Storage Server 2008 R2 operating system restarts.
8. Press the **Delete** key several times during startup until you see “Entering Setup.”
9. Set the USB Drive to boot first. Navigate to the Boot tab > Hard Disk Drives > 1st Drive and select the default USB setting detected by the BIOS. The 2nd Drive setting changes to the “RAID: Intel Volume.”



Depending on the manufacturer of the USB flash drive, the USB selection in the BIOS changes.

10. Select the Advanced tab > CPU Configuration, make sure the hyper thread option “Intel HT Technology” is [Disabled].
11. Select the Advanced tab > APM Configuration, make sure “Restore on Power Loss” is set to [Last State].
12. Press **F10** to Exit and Save your changes.
The system continues to start from the USB flash drive.
Wait until two windows appear, click on the blue window and select one of the available options:
 - Recover the OS partition only.
 - Recover the entire system disk.
 - Exit without doing a recovery.
13. At the prompt, type the number of the operation you want to perform:
 - ▶ If you type **1** or **2**, a warning screen opens, informing you that you are about to recover the operating system. Continue with step 14.
 - ▶ If you type **3**, the recovery quits to the Main menu. You need to type **3** again to get to command window. Press **Ctrl+Alt+Delete** to quit in any of these windows.
14. A yellow screen appears type **Y**.
15. A red screen appears type **Y**.

The reimaging takes 20 to 30 minutes.



Do not remove the USB flash drive while performing the product recovery. If you remove the USB flash drive an error is displayed stating it cannot write the Ghosterr.txt file. If the USB flash drive was removed, you cannot continue the process by re-installing the USB flash drive. You would have to start the recovery process from the beginning.

16. A gray screen prompts you to reboot. Type **R**, and quickly remove the USB flash drive from the system.

Configure the operating system as described in the following section. The Apply Computer Setup message is displayed for 3 to 5 minutes.

Configuring the System Drive Using Windows 2008 Storage Server Setup

After you recover the Windows Storage Server 2008 R2 operating system, several system parameters are set including a system Disk Check. The system restarts, and you are prompted to enter the Windows activation key. This number is on the Windows Certificate located on the System Director top cover. You need this Windows number in the following procedure.

To set up the Windows operating system:

1. (If removed) Reconnect all the network Ethernet cables.
2. After the system has restated, select the country, time, and keyboard settings and click Next.
3. When the Product Key screen opens, type the Product Key from the Certificate of Authenticity in the Product Key text box. The certificate is on the top of the Avid ISIS System Director.



The Product Key Authenticity is verified with Microsoft through an Internet connection. If you do not have the Avid ISIS connected to an in-house network, you need to phone in your Product Key and get an Authenticity number back from Microsoft.

The Windows Storage Server 2008 R2 Setup utility starts, and the a dialog box opens showing the License Agreement screen.

4. Click Next.
5. Select “I accept the license terms.”
6. Click Next.
7. Log on as **Administrator** and **is-admin** as the password.
8. After log on, customize the system and local settings. See the Windows documentation for more information.
 - ▶ Customize the system and local settings.

- ▶ You might want to create a new *system administrator name* and *password*.
- ▶ Company Name and Organization.
- ▶ Date and Time Settings.
- ▶ Network Workgroup and Computer Domain settings.



When the operating system is restored in the Avid ISIS Engine, a unique computer host name is created based on the MAC ID of the system board. Each time you re-image your Avid ISIS Engine, the same name will be generated. If you have changed the computer host name of your Avid ISIS Engine, you need to reapply your computer host name again.

9. Start the system and install Avid ISIS software, see [“Loading the Software”](#) on page 65.

13 Specifications and Notices

This section provides information on the dimensions and weight, the environmental, the electrical, and the power cord specifications for the Avid AS3000 when used as the ISIS 2000 System Director. It also recommends the use of an Uninterruptible Power Supply and supported network cabling.

Dimensions and Weight

The following table lists the dimensions and weight.

Component Dimensions and Weight

Component	Height	Width	Depth	Weight
AS3000 System Director	1.75 in (44.4 mm)	19 in (482.6 mm)	27 in (685.8 mm)	40.0 lb (18.1 kg) with drives installed
ISIS 2000 Engine	8.75 in (222.3mm)	19 in (482.6 mm)	36 in (915 mm)	287.5 lb (130.4 kg) with 84 drives installed

Environment

The following table lists the environmental specifications.

Environmental Specifications

Component	Operating Temperature	Operating Humidity	Storage Temperature
AS3000 System Director	41°F to 95°F (5°C to 35°C)	5% to 95% (at 38°C) non-condensing	-4°F to 140°F (-20°C to 60°C)
ISIS 2000 Engine	41°F to 95°F (5°C to 35°C)	20% to 80% non-condensing	-40°F to 158°F (-40°C to 70°C)

Electrical

The power cable that comes with the ISIS 2000 Engine is a C19 to 20 power cable. The C19 end is a female connector which plugs into the power supply on the Engine. The C20 end is a male connector, used to plug into a Power Distribution Unit (PDU) with C19 style connectors. The following table lists the electrical specifications.

Electrical Specifications

Component	Voltage	Frequency	Watts (Max. U.S.)
AS3000 System Director	100 to 240 Vac Two hot-swap redundant AC power supplies	50 to 60 Hz	650 W
ISIS 2000 Engine	208 to 240 Vac Two hot-swap redundant AC power supplies	50 to 60 Hz	2800 W 9554 BTU 13 amps (maximum) 10 amps (typical)

Uninterruptible Power Supply (UPS)

Avid highly recommends you create a separate derived power system for your ISIS 2000 System Director. This provides protection against sudden power surges or losses that could cause you to lose files or experience data corruption. The power outlets need to be from the same distribution panel. This helps prevent ground loops that can be caused by plugging equipment into power sources with different ground potentials. Make sure there is adequate, dedicated power for the UPSs.



You should have all the electrical work at your site done by a licensed electrician. The electrical changes must meet country, state, and local electrical codes.

The ISIS 2000 System Director supports UPS devices that are connected using network connections, USB connections, and serial connections. Install the software from the UPS manufacturer for advanced shutdown behavior, calibrate the UPS device. These software packages also allow for a connected Windows server to send alerts to other Windows servers to perform actions.

If your ISIS 2000 System Director is connected to a network, network policy settings might also prevent you from completing this procedure. Make sure there is adequate power and the correct receptacle type for each hardware component, the rack power strips, and the UPSes. Do not use extension cords to plug in any of the hardware components.

Supported Cabling

Avid supports the following cable types for connecting an ISIS 2000 System Director system.



If you need run your cable greater distances, call Avid Customer Support for supported cable and accessory information.





Supported Cables

Cable Connection Type	Function	Connector Style and Maximum Cable Length
Ethernet network cable, Cat 5e, Cat 6, Cat 6a or Cat 7	Connects: Ethernet shared storage clients System Directors and clients to 1 Gb ports on an ISS Avid Interplay servers to shared storage networks Avid AirSpeed capture and playback servers to shared storage networks Avid ISIS management port to a laptop	RJ45 connector 100 Meters; If using CAT5e the cable must be rated for 350 MHz for maximum length. The minimum GigE cable length for Avid network products is 6 feet or 2 meter.

Supported Cables

Cable Connection Type	Function	Connector Style and Maximum Cable Length
Optical cables	Connects: 1 Gb switch port to 1 Gb client <ul style="list-style-type: none"> • Windows – Intel Pro 1000 PF • Macintosh – Small Tree PEG2F 10-Gb port of switch to optical 10-Gb port on the Avid ISIS Engine. ISS 10-Gb optical port to switch port ISS 10-Gb optical port to 10-Gb Ethernet Client 10-Gb Client to 10 Gb Switch port 10-Gb Ethernet switch to 10-Gb Ethernet Switch ISS to 10-Gb adapter in Move/Copy service	<p>The maximum length for optical Ethernet cables is limited by the core diameter (measured in microns) and modal bandwidth (in units of MHz*km).</p> <p>Avid supports multi-mode fiber (MMF) cable using 850 nm transceivers (1000BASE-SX short distances). Specifications for these cables can be found in the ISO 11801 structured cabling document.</p> <ul style="list-style-type: none"> • OM1 (62.5/125) — <ul style="list-style-type: none"> - 100 Mb Ethernet, up to 2000 meters (FX) - 1 Gb Ethernet, 275 meters (SX) - 10 Gb Ethernet, 33 meters (SR) • OM2 (50/125) — <ul style="list-style-type: none"> - 100 Mb Ethernet, up to 2000 meters (FX) - 1 Gb Ethernet, 550 meters (SX) - 10 Gb Ethernet, 82 meters (SR) • OM3 (50/125) — <ul style="list-style-type: none"> - 100 Mb Ethernet, up to 2000 meters (FX) - 1 Gb Ethernet, 550 meters (SX) - 10 Gb Ethernet, 300 meters (SR) • OM4 (50/125) — <ul style="list-style-type: none"> - 100 Mb Ethernet, up to 2000 meters (FX) - 1 Gb Ethernet, 1000 meters (SX) - 10 Gb Ethernet, 550 meters (SR) <p>Avid supports single-mode fiber cable using 1310 nm transceivers (long distances):</p> <ul style="list-style-type: none"> • SMF ITU G.652.A/B 9 micron cable up to 10 km

Supported Cables

Cable Connection Type	Function	Connector Style and Maximum Cable Length
 When connecting to the 10 Gb port, it is important to follow two rules: – Ensure that the cable has the required modal bandwidth for the distance of the run. – Make sure that all multimode cables between an switch port and the other end of the cable run are of the same diameter (for example, 50/125 um or 62.5/125 um).		
 Single mode transceivers are Class 1 laser product per IEC 60825-1 Amendment 2(2001) and IEC 60825-2 1997. Operating this product in a manner inconsistent with intended usage and specification may result in hazardous radiation exposure.		
Avid ISIS X2 optical transceivers	Transceiver used in: Cisco C4948-10GE and C4900M	SC connector X2 = Cisco X2-10GB-SR for MMF X2 = Cisco X2-10GB-LR for SMF  <i>The minimum cable length for -LR and -SR transceivers is 2 meters.</i>
Avid ISIS XFP optical transceivers	Transceiver used in: Force10 S25N and S25P switches and ISIS 7500 7000 ISS 1000	LC connector XFP = 10G-XFP-SR for MMF XFP = 10G-XFP-LR for SMF XFP = 10G-XFP-SR or Picolight XXL-SC-S45-21 for MMF XFP = 10G-XFP-LR or Bookham 10G-BASE-LR for SMF  <i>The minimum cable length for -LR and -SR transceivers is 2 meters.</i>
Avid ISIS SFP+ optical transceivers	Transceiver used in: Force10 S25P and S60 optical switches and ISIS ISS2000	LC connector <ul style="list-style-type: none"> • SFP+ multi-mode short range (SR) 850nm JDSU – PLRXPL-SC-S43-21-N JDSU – PLRXPL-SC-S43-22-N Avago – AFBR-700SDZ Avago – AFBR-703SDZ • SFP+ long range (LR) Finisar FTLX1471D3BCL for SMF Avago AFCT-701SDZ for SMF JDSU JSH-01LWAA1 for SMF  <i>The minimum cable length for -LR and -SR transceivers is 2 meters.</i>

Supported Cables

Cable Connection Type	Function	Connector Style and Maximum Cable Length
	Cisco C4948E	SPF+ – 10G-SR for MMF SPF+ – 10G-LR for SMF  <i>The minimum cable length for -LR and -SR transceivers is 2 meters.</i>

A Safety and Regulatory Information

This document contains safety and regulatory information for Avid hardware.

- [Warnings and Cautions](#)
- [FCC Notice](#)
- [Canadian Notice \(Avis Canadien\)](#)
- [LED Safety Notices](#)
- [European Union Declaration of Conformity](#)
- [Disposal of Waste Equipment by Users in the European Union](#)
- [Argentina Conformity](#)
- [Australia and New Zealand EMC Regulations](#)
- [Japan EMC Regulations](#)
- [Korean EMC Regulations](#)
- [Taiwan EMC Regulations](#)

Warnings and Cautions



This equipment is intended only for installation in a RESTRICTED ACCESS LOCATION.



Never install equipment if it appears damaged.



Disconnect the power cord before servicing unit.



Only perform the services explicitly described in this document. For services or procedures not outlined in this document, speak with authorized Avid service personnel.



Follow all warnings and cautions in the procedures.



Operate the device within its marked electrical ratings and product usage instructions.



If you need to replace a battery in an Avid hardware unit, be sure to use the correct battery type. There might be a risk of explosion if a battery is replaced by an incorrect type. Dispose of used batteries according to the manufacturer's instructions.



For products with a power switch the main power switch should remain accessible after installation.

(Hebrew Warnings and Cautions)

הנחיות זהירות

 אין להתקין ציוד הנראה פגום.

 יש לנתק את כבל החשמל לפני הטיפול ביחידה.

 יש לבצע אך ורק את הטיפולים המתוארים במפורש במסמך זה. עבור טיפולים או הליכים שאינם מתוארים במסמך זה, יש לפנות לאיש שירות מוסמך ומורשה של Avid.

 בביצוע ההליכים, יש להישמע לכל הנחיות הזהירות.

 יש להפעיל את המכשיר במסגרת הדירוגים החשמליים והנחיות השימוש במוצה.

 אם יש צורך להחליף את הסוללה ביחידת חומרה של Avid, יש להקפיד להשתמש בסוג הסוללה הנכון. קיים סיכון להתפוצצות אם הסוללה מוחלפת בסוללה מסוג שגוי. יש להשליך סוללות משומשות בהתאם להנחיות היצרן.

FCC Notice

Part 15 of the Federal Communication Commission Rules and Regulations has established Radio Frequency (RF) emission limits to provide an interference free radio frequency spectrum. Many electronic devices produce RF energy incidental to their intended purpose.

Class A Equipment

This equipment has been tested and found to comply with the limits for a Class A digital device, pursuant to Part 15 of the FCC rules. These limits are designed to provide reasonable protection against harmful interference when the equipment is operated in a commercial environment. This equipment generates, uses, and can radiate radio frequency energy and, if not installed and used in accordance with the instructions, may cause harmful interference to radio communications. Operation of this equipment in a residential area is likely to cause harmful interference, in which case the user will be required to correct the interference at personal expense.

Modifications

The FCC requires the user to be notified that any changes or modifications made to Avid hardware that are not expressly approved by Avid Technology may void the user's authority to operate the equipment.

Cables

Connections to Avid hardware must be made with shielded cables with metallic RFI/EMI connector hoods in order to maintain compliance with FCC Rules and Regulations.

Canadian Notice (Avis Canadien)

Class A Equipment

This Class A digital apparatus meets all requirements of the Canadian Interference-Causing Equipment Regulations.

Cet appareil numérique de la classe A respecte toutes les exigences du Règlement sur le matériel brouilleur du Canada.

LED Safety Notices

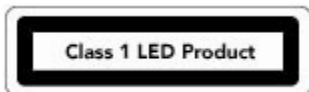

Avid hardware might contain LED or Laser devices for communication use. These devices are compliant with the requirements for Class 1 LED and Laser Products and are safe in the intended use. In normal operation the output of these laser devices does not exceed the exposure limit of the eye and cannot cause harm.

Standard to which conformity is declared: (Class 1 LED Product per IEC 60825-1:2007)

(Hebrew LED Safety Notices)

הוראות בטיחות של נורות LED



חומרת Avid עשויה לכלול נורות LED או התקני ליזר לצורך תקשורת. התקנים אלה תואמים לדרישות עבור נורות LED ומוצרי ליזר מסוג Class 1, והינם בטוחים לשימוש כראוי. בהפעלה רגילה, הפלט של התקן ליזר זה אינו חורג ממגבלת החשיפה של העין, ואינו יכול לגרום לנזק.

תקן ההתאמה המוצהר: (בטיחות עין מסוג Class 1 לפי דרישות
(CDRH / 1-60825 IEC

European Union Declaration of Conformity



Declaration of conformity
Konformitätserklärung
Déclaration de conformité
Declaración de Confomidad
Verklaring de overeenstemming
Dichiarazione di conformità

We/Wir/Nous/WIJ/Noi:

Avid Technology
75 Network Drive
Burlington, MA, 01803 USA

European Contact: Nearest Avid Sales and Service Office or
Avid Technology International B.V.
Sandyford Industrial Estate
Unit 38, Carmanhall Road
Dublin 18, Ireland

declare under our sole responsibility that the product,
erklären, in alleniniger Verantwortung, daß dieses Produkt,
déclarons sous notre seule responsabilité que le produit,
declaramos, bajo nuestra sola responsabilidad, que el producto,
verklaren onder onze verantwoordelijkheid, dat het product,
dichiariamo sotto nostra unica responsabilità, che il prodotto,

Product Name(s): ISIS 2000

Model Number(s): 7020-30088-XX

Product Option(s): This declaration covers all options for the above product(s).

to which this declaration relates is in conformity with the following standard(s) or other normative documents.

auf das sich diese Erklärung bezieht, mit der/den folgenden Norm(en) oder Richtlinie(n) übereinstimmt.

auquel se réfère cette déclaration est conforme à la (aux) norme(s) ou au(x) document(s) normatif(s).

al que se refiere esta declaración es conforme a la(s) norma(s) u otro(s) documento(s) normativo(s).

waarnaar deze verklaring verwijst, aan de volende norm(en) of richtlijn(en) beantwoordt.
a cui si riferisce questa dichiarazione è conforme alla/e seguente/i norma/o documento/i normativo/i.

The requirements of the European Council:

Safety: Directive 2006/95/EC

UL 60950-1, 2nd edition

CAN/CSA-C22.2 No. 60950-1-07; 2007

IEC 60950-1, 2nd edition

EN 60950-1:2006

EMC: Directive 2004/108/EC

EN55022:2006 /A1:2007

EN55024:1998 /A1:2001 /A2:2003

EN61000-3-2:2006

EN61000-3-3:2008

Issued In Burlington MA, USA 2010

Disposal of Waste Equipment by Users in the European Union



This symbol on the product or its packaging indicates that this product must not be disposed of with other waste. Instead, it is your responsibility to dispose of your waste equipment by handing it over to a designated collection point for the recycling of waste electrical and electronic equipment. The separate collection and recycling of your waste equipment at the time of disposal will help conserve natural resources and ensure that it is recycled in a manner that protects human health and the environment. For more information about where you can drop off your waste equipment for recycling, please contact your local city recycling office or the dealer from whom you purchased the product.

Argentina Conformity



Made in USA

Australia and New Zealand EMC Regulations

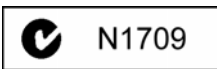

Ken Hopkins
Avid Technology (Aust) Pty Ltd
c/o – Elliot House
Suite 810, Level 8
140 Arther St
North Sydney
NSW – 2060

Japan EMC Regulations

Class A Equipment

This is a Class A product. In a domestic environment this product may cause radio interference in which case the user may be required to take corrective actions. VCCI-A

この装置は、クラスA情報技術装置です。この装置を家庭環境で使用すると電波妨害を引き起こすことがあります。この場合には使用者が適切な対策を講ずるよう要求されることがあります。 VCCI-A

Korean EMC Regulations

Class A Equipment

Please note that this equipment has obtained EMC registration for commercial use. In the event that it has been mistakenly sold or purchased, please exchange it for equipment certified for home use.

이 기기는 업무용(A급) 전자파적합기기로서 판매자 또는 사용자는 이 점을 주의하시기 바라며, 가정외의 지역에서 사용하는 것을 목적으로 합니다.

Taiwan EMC Regulations

Taiwan EMC Regulations BSMI Class A EMC Warning

警告使用者:

這是甲類的資訊產品，在居住的環境中使用時，可能會造成射頻干擾，在這種情況下，使用者會被要求採取某些適當的對策。

Warning Statement

1. UV ray radiation

- Following statement or equivalent:

警告：開啟前請先關閉UV燈

- Following marking or other equivalent marking:



2. Operator touchable area protection

Operation manual should have following statement and statement should be shown on device, or put on similar sentence:

警告

危險可動部位

請遠離手指及身體其他部位

3. Heat-related hazards

Injury may result from high temperatures under normal operating conditions, causing:

- Burns due to contact with hot accessible parts
- Degradation of insulation and of safety-critical components
- Ignition of flammable liquids

Examples of measures to reduce risks include:

- Taking steps to avoid high temperature of accessible parts
- Avoiding temperatures above the ignition point of liquids
- Provision of marking to warn USERS where access to hot parts is unavoidable

High temperature warning marking — you may use the following high temperature warning marking:



4. Mechanical hazards

Injury may result from:

- Sharp edges and corners
- Moving parts which have the potential to cause injury
- Equipment instability
- Flying particles from imploding cathode ray tubes and exploding high pressure lamps

Examples of measures to reduce risks include:

- Rounding of sharp edges and corners
- Guarding
- Provision of SAFETY INTERLOCKS
- Providing sufficient stability to free-standing equipment
- Selecting cathode ray tubes and high pressure lamps that are resistant to implosion and explosion respectively
- Provision of markings to warn USERS where access is unavoidable

5. Radiation

Injury to USERS and to SERVICE PERSONS may result from some forms of radiation emitted by equipment.

Examples are sonic (acoustic), radio frequency, infra-red, ultraviolet and ionizing radiation, and high intensity visible and coherent light (lasers).

Examples of measures to reduce risks include:

- Limiting the energy level of potential radiation sources
- Screening radiation sources
- Provision of SAFETY INTERLOCKS
- Provision of markings to warn USERS where exposure to the radiation hazard is unavoidable

6. Chemical hazards

Injury may result from contact with some chemicals or from inhalation of their vapors and fumes.

Examples of measures to reduce risks include:

- Avoiding the use of constructional and consumable materials likely to cause injury by contact or inhalation during intended and normal conditions of use
- Avoiding conditions likely to cause leakage or vaporization
- Provision of markings to warn USERS about the hazards

7. Safety warning statement for equipment that is under hazardous voltages

8. Equipment with touch current exceeding 3.5 mA

One of the following labels, or a label with similar wording, shall be affixed adjacent to the equipment AC MAINS SUPPLY connection:

警告

高漏電流

在連接電源前須確實接地

- 9. An EUT that provides TELECOMMUNICATIONS NETWORK connection ports for connection of multiple items of other telecommunications equipment shall not create a hazard for USERS and TELECOMMUNICATIONS NETWORK SERVICE PERSONS due to summation of TOUCH CURRENT**

警告

高漏電流

在連接電信網路

前須確實接地

警告

高接觸電流

在連接電信網路

前須確實接地

10. Replaceable batteries

If an equipment is provided with a replaceable battery, and if replacement by an incorrect type could result in an explosion (for example, with some lithium batteries), the following applies:

- If the battery is placed in an OPERATOR ACCESS AREA, there shall be a marking close to the battery or a statement in both the operating and the servicing instructions
- If the battery is placed elsewhere in the equipment, there shall be a marking close to the battery or a statement in the servicing instructions

The marking or statement shall include the following or similar text:

警 告

本電池如果更換不正確會有爆炸的危險

請依製造商說明書處理用過之電池

11. Warning to service persons

Suitable markings shall be provided on the equipment or a statement shall be provided in the servicing instructions to alert a SERVICE PERSON to a possible hazard, where both of the following conditions exist:

- Where a fuse is used in the neutral of single-phase equipment either permanently connected or provided with a non-reversible plug
- Where, after operation of the fuse, parts of the equipment that remain energized might represent a hazard during servicing

The following or similar wording is regarded as suitable:

注意

雙極性 / 中性線已接熔線

Index

A

- Access to system [34](#)
- Accounts, users [79](#)
- Activating software [105](#)
 - without Internet connection [107](#)
- Activation ID [104](#)
- Adding remote host [88](#)
- Addresses
 - virtual [96, 99](#)
- Administrator
 - agent page password [56, 76, 125, 129, 163, 182](#)
 - Management Console password [55, 78](#)
 - operating system password [184](#)
- After [188](#)
- Agent page [128, 131, 163, 167, 170](#)
- Allocation group [79](#)
- Amber LED [21](#)
- anti-static wrist or ankle strap [157](#)
- Application key
 - see Licence key [71](#)
- Argentina Conformity [201](#)
- Australia EMC regulations [201](#)
- Auto-connect (Client Manager) [87](#)
- Autorun.exe file [65, 125, 127](#)
- Avago, SFP+ [194](#)
- Avid
 - online support [12](#)
 - training services [13](#)
 - web site [70](#)
- Avid License Control tool [69](#)

B

- Bind Storage Elements [78](#)
- Binding order [101](#)
- Boards, space for changing [34](#)

Button

- NMI [17](#)
- power [17, 20, 23](#)
- system reset [17, 20](#)

C

Cable

- length [192](#)
- micron [193](#)
- multi-mode fiber [193](#)
- OM2, OM3 [193](#)
- optical [193](#)
- specifications [193](#)

Cables

- Category 5 or 6 [192](#)
- described [31](#)
- space for connecting [34](#)
- supported [192](#)

Canadian

- interference causing equipment regulations [198, 202, 202](#)

Category 5 or 6 cables [192](#)

Chassis *See* Engine

Checklist

- health of system [123, 157](#)
- preupgrade [134](#)

Cisco [194, 194, 194, 195](#)

Clear foreign config [128, 163, 167, 170](#)

Clear foreign disk configuration [128, 131, 163, 167, 170](#)

Clearance [34](#)

Client

- architecture [27](#)
- installers [83](#)
- operating systems [15](#)

Client Manager

- auto-connect [87](#)

- connecting from Zone clients 88
- documentation 12, 65
- Preferences dialog box 88
- Client Manager maintenance 142
- Complete shutdown 142
- Components, space for changing 34
- Configure
 - FTP 116
 - System Director Control Panel 72, 93, 97, 103
 - virtual name 72, 93, 97, 103
 - Windows operating system 188
- Configure the Virtual Addresses 96, 99
- Connecting cables 34
- Connector
 - USB 16
- Control panel
 - System Director 72, 93, 97
- Control panel, System Director 16, 20, 139
- Cooling module
 - described 21
- Cooling modules
 - location 21
- Create
 - New Active file system 73, 95, 98
 - Workspaces 79
- Create New Active 72, 93, 97, 103
- Create spare disk
 - Advanced tab
 - Create spare disk 128, 131, 163, 167, 170
- Crossover connection validation 100

D

- Daily maintenance 138
- Deactivate License software 109
- Device ID 105
- Dimensions 190
- Documentation
 - client software 12, 65
- Drive
 - activity 17
 - flash 184
- Dump metadata 72, 93, 97, 103

E

- EIA rack units 33, 42

- Enclosure Management 157
- Enclosure storage 25
 - Upgrade 127
- Engine
 - configurations 25
 - described 18
 - front view 19
 - media drive slots 25
 - power supplies 21
 - rear view 21
 - replacement 170
 - upgrade 127
- Engine Controller
 - Controller, Engine 21
 - Engine Controller shutdown 129, 168, 171
- Engine Post Configuration 70
- Environmental requirements 190
- ESD precautions 144
- European Union notice 199

F

- Failover
 - binding order 101
 - described 18
- Fan LED 156
- Fans 21, 22
- Fault indicator LEDs 21
- FCC notice 197
- Flash drive
 - recovery 184
 - USB 65
- Flash software 84
- Format foreign disks 131
- Format foreign disks *See* Clear foreign config
- Foundry 194
- Front panel controls, System Director 16, 19
- FTP, configure 116

G

- Green LEDs 17, 21
- Groups, RAID 25

H

- Hardware Faults 144

Health check [123](#), [157](#)
 Health Monitor [101](#)
 Host [88](#)
 Host name change, System Director [110](#)

I

Indicator
 fault [23](#)
 Indirect license activation [107](#)
 Initial slot configuration [25](#)
 Install software [65](#)
 Installation, in a rack [33](#)
 Installer
 splash screen [65](#)
 Installer kit [65](#)
 Intel Network Connections [68](#)
 Internal
 space for changing drives [34](#)
 Interplay Framework [101](#)
 ISIS Client Installers [69](#), [69](#)
 ISIS SNMP Extension Agent [69](#)

J

JDSU [194](#)
 JDSU, SFP+ [194](#)

K

KVM switch [54](#)

L

Launch pad icon [81](#), [102](#)
 LED [144](#)
 fan [156](#)
 power supply [23](#)
 system drive [17](#)
 system ID [17](#), [20](#)
 system status [17](#), [21](#)
 Length, cable [192](#)
 License key
 activation [71](#)
 License software
 activation [105](#)
 deactivate [109](#)

 host name change [110](#)
 Loading software [65](#)
 Log in [78](#)

M

Macintosh clients [82](#)
 Maintenance
 check system health [123](#), [157](#)
 Client Manager [142](#)
 daily [138](#)
 weekly [140](#)
 Management Console
 bind [78](#)
 password [55](#), [78](#)
 Maximum
 storage [24](#)
 Maximum length [192](#)
 Micron cable [193](#)
 Modal bandwidth [193](#)
 Module locations [21](#)
 Monitor
 VGA connector [54](#)
 Multi-mode fiber cable [193](#)
 Myricom Network Connection [68](#)

N

Network
 activity LEDs [17](#)
 zones [29](#)
 Network connection
 binding order [101](#)
 New Zealand EMC regulations [201](#)
 NMI (non-maskable interrupt) button [17](#), [20](#), [23](#)
 No spare, import disk [128](#), [131](#), [163](#), [167](#), [170](#)

O

Online support [12](#)
 Operating system
 clients [15](#)
 configure [188](#)
 reinstall [186](#)
 Operating system password [184](#)
 Optical cable [193](#)

P

- Packets received [100](#)
- Password
 - agent page [56, 76, 125, 129, 163, 182](#)
 - Management Console [55, 78](#)
 - operating system [184](#)
 - System Director [15, 55, 117](#)
- PathDiag Tool [132](#)
- Power
 - button [17, 20, 23](#)
 - cord connection [53](#)
 - specifications [191](#)
- Power supply
 - described [22](#)
 - location [21](#)
- Power switch [23](#)
- Preferences (Client Manager) [88](#)
- Preupgrade information [134](#)
- Product recovery, flash drive [184](#)

R

- Rack
 - installation [41](#)
 - mounting instructions [33](#)
 - position [35](#)
 - rack units [35](#)
 - requirements [34](#)
- Rack-mount
 - installation [33, 42](#)
 - requirements [34](#)
- RAID 6 groups [25](#)
- Rear panel, System Director [17](#)
- Received packets [100](#)
- Recommended maintenance [138](#)
- Recovery flash drive [184](#)
- Red LED [17](#)
- Regulatory information [197](#)
- Reinstall Windows [186](#)
- Remote Host [88](#)
- Replace
 - engine [170](#)
 - switch [178](#)
- Requirements for rack mounting [34](#)

S

- Safety information [197](#)
- Server room shutdown [142](#)
- Servicing, space for [34](#)
- SFP+ [194](#)
- Shutdown [129, 168, 171](#)
- Shutdown server room [142](#)
- Slot
 - storage configuration [25](#)
 - storage upgrade configuration [127](#)
- Software
 - Flash [84](#)
 - installer described [67, 67, 68](#)
 - license [105](#)
 - loading [65](#)
- Software upgrade [124, 179](#)
- Space for changing components [34](#)
- Specifications
 - dimensions and weights [190](#)
 - environmental [190](#)
 - power [191](#)
- Splash screen [65](#)
- Status messages
 - storage elements [139](#)
- Stop System Director [72, 93, 97, 103](#)
- Stop/Start server [72](#)
- Storage Blade
 - password [55](#)
- Storage drive
 - function [18](#)
 - slot positions [19](#)
- Storage elements [24](#)
 - See also* Storage blade
 - status [139](#)
- Storage Groups
 - size [24](#)
- Storage limit [24](#)
- Storage Manager Agent
 - default password [128, 131, 167, 170](#)
 - password [163](#)
- Supported cables [192](#)
- Switch
 - KVM [54](#)
 - replacement [178](#)
 - VLAN for ISIS 2000 [29, 71](#)
- System [17](#)

- drive LED 17
- fault indicator 23
- ID LED 17
- power supply LED 23
- reset button 17, 20
- status LED 17, 21
- unit ID LED 20
- System Director
 - 2U rack size 15
 - Control Panel 72, 93, 97, 103, 139
 - Create New Active file system 73, 95, 98
 - front control panel 16, 20
 - front panel 16, 19
 - host name change 110
 - log in 78
 - password 15, 55, 78, 117
 - rear panel 17
 - recovery 184
 - second 18
 - software 68
 - stop/start service 72
- System disk 16, 19
- System error 17, 21
- System ID 105

T

- Taiwan EMC regulations 202
- Task bar icon 81, 102
- Thermal
 - alarm 156
 - monitoring 155
- Training services 13
- Transceivers 194, 194
- Troubleshooting 12
 - check health 123, 157
 - recommended maintenance 138

U

- Upgrade
 - media drives 116
 - post upgrade verification 132
 - preupgrade checklist 134
 - procedure 124, 179
 - software 124, 179
- USB (universal serial bus)

- connector 16
- flash drive 65, 184
- keyboard and mouse 54
- port described 16
- software installer 65

User

- accounts 79

Utility

- list of available tools 141

V

- Validate crossover connection 100
- Verification of upgrade 132
- VGA monitor 54
- Virtual Addresses, configure 96, 99
- Virtual name 72, 93, 97, 103
- VLAN, for ISIS 2000 switch 29, 71

W

- Weekly maintenance 140
- Weight 190
- Windows
 - 2008 operating system 15
 - event logs 140
 - reinstall 186
- Windows clients 82
- Windows Update 83
- Workspaces
 - create 79

Z

- Zone
 - examples 29
 - VLAN for ISIS 2000 Switch 29, 71
- Zone clients 88



Avid
75 Network Drive
Burlington, MA 01803-2756 USA

Technical Support (USA)
Visit the Online Support Center at
www.avid.com/support

Product Information
For company and product information,
visit us on the web at www.avid.com