

***Minuteman***<sup>®</sup>  
*Excellence Meets Clean*

# Operating Manual

**ERide 30**

## Introduction

### Preface

Dear Customer,

We are certain that the excellent qualities of the vehicle will justify the faith you have shown in us through your purchase.

Please read the Chapter "Safety Information" prior to starting the vehicle to ensure it is operated and used safely. Your safety, and that of others, basically lies in your ability to control and operate the vehicle. Before using the equipment for the first time, read this original manual thoroughly, act according to the information contained and keep it in a safe place for future reference or subsequent owners. The operating manual contains all the most important information regarding operation, maintenance and service.

Throughout this manual, texts which concern safety are indicated by the corresponding danger pictogram. If you have any questions with regard to the machine or operating manual, you can contact your Minuteman service partner at any time.

We explicitly point out that no legal claims may be asserted based on the information contained in this manual. Ensure only original spare parts are used should any repairs be necessary. Only such original spare parts warrant that the equipment is reliably ready to use at all times. We reserve the right to make technical modifications in the interest of further development.

Valid as of: May 2013

**Minuteman International**  
**14N845 U.S. Route 20**  
**Pingree Grove, IL 60140**  
**Phone: (847) 264-5400**  
**FAX: (847) 683-5207**

### Intended use

The ERide 30 is a scrubber dryer for the wet cleaning of hard floors. Any use beyond this is regarded as improper use. The manufacturer is not considered liable for any damage resulting from improper use; the user is solely responsible for all the potential risks involved. Intended use also includes maintaining and observing the operating, maintenance and repair conditions prescribed by the manufacturer.

The ERide 30 may only be operated, serviced and repaired by personnel who are familiar with the work involved and are aware of the risks.

The applicable accident prevention laws must be observed and any generally accepted health and safety directives must be maintained.

Based on the conception, design and construction of the vehicle introduced onto the market by us, the vehicle complies with the applicable basic safety and health requirements stipulated in the EC Directive (refer to the Declaration of Conformity). This declaration is no longer considered valid in the event of modifications to the vehicle not authorized by us. The manufacturer is not

## Introduction

deemed liable for any damage resulting from unauthorized modifications to the vehicle.

### Notes on warranty

As a fundamental rule, the regulations in the purchase agreement apply. There are no rights to claims for compensation under the terms of warranty when the damage is a result of failure to observe the stipulations concerning service and maintenance. Maintenance work must be completed by an authorized Minuteman service center and confirmed in the “maintenance log-book”; this serves as proof of rights to claims under the terms of warranty. The following are excluded from the terms of warranty: normal wear and tear and damage caused by overuse, defective fuses, improper handling or unauthorized modifications. Claims under the terms of warranty are also annulled when damage occurs to the machine as the result of the use of parts and accessories not explicitly approved by us or to failure to observe maintenance procedures.

### Acceptance of the vehicle

The vehicle must be inspected directly after delivery for signs of transport damage. Replacements for transport damage will be made when confirmation is provided immediately by the transporting company with regard to the damage and you send the damage report to our authorized contractual partner together with the consignment note.

### Disposal

Render the vehicle inoperable. It must not represent a source of danger for children. Dispose of the equipment in accordance with local regulations. For further information on handling and recycling, please contact the authorized dealer where you purchased the vehicle.



Used batteries with the recycling symbol contain reusable commodities. The heavy metals contained represent a major risk both to people's health and to the environment. Never open or damage batteries. Never touch, inhale or swallow the content of batteries. Health hazard! Do not allow batteries to get into the environment. Risk of contaminating the ground and water! In accordance with symbol with the crossed out garbage bin, these batteries must not be disposed of in domestic waste.

## Table of Contents

Preface . . . . .	2	2.3.2 Charging the battery . . . . .	19	<b>4</b>	<b>Technical Data . . . . .</b>	<b>45</b>
Notes on warranty . . . . .	3	2.3.3 Emptying the waste water tank . . . . .	21	<b>5</b>	<b>Maintenance and Service . . . . .</b>	<b>48</b>
Disposal . . . . .	3	2.3.4 Filling the clean water tank . . . . .	22	5.1	Minuteman system maintenance . . . . .	48
<b>1 Safety Information . . . . .</b>	<b>6</b>	2.3.5 Adjusting the driver's seat . . . . .	23	5.2	Proof of Maintenance . . . . .	49
1.1 Safety and warning labels . . . . .	6	2.3.6 Switching the vehicle on . . . . .	24	5.3	Maintenance Plan . . . . .	50
1.2 General information . . . . .	7	2.3.7 Driving and braking behavior . . . . .	25	5.4	Battery system . . . . .	54
1.3 Operating information . . . . .	7	2.3.8 Pushing the vehicle . . . . .	25	5.4.1	Water filling system . . . . .	55
1.4 Maintenance information . . . . .	8	2.3.9 Charge status indicator . . . . .	26	5.4.2	Charge status indicator (TSG) . . . . .	55
1.5 Particular risks . . . . .	9	2.3.10 Switching the vehicle off . . . . .	27	5.4.3	Servicing the driving batteries . . . . .	55
1.6 Environmental protection . . . . .	10	2.3.11 After completing cleaning . . . . .	28	5.4.4	Disposing of batteries . . . . .	55
1.7 Labels on the vehicle . . . . .	11	2.4 Service code table . . . . .	29	5.5	Waste water and clean water tank . . . . .	56
<b>2 Operation . . . . .</b>	<b>14</b>	2.5 Loading and transporting . . . . .	30	5.5.1	Cleaning the clean water r tank . . . . .	57
2.1 Unpacking . . . . .	14	2.6 Special equipment and accessories . . . . .	31	5.5.2	Cleaning the clean water filter . . . . .	57
2.2 Prior to starting up for the first time . . . . .	14	<b>3 Operation . . . . .</b>	<b>33</b>	5.5.3	Cleaning the waste water tank . . . . .	57
2.2.1 Instruction . . . . .	14	3.1 Method of operation . . . . .	33	5.6	Disk brush head . . . . .	58
2.2.2 Assembling the squeegee . . . . .	14	3.2 Operating and indicator elements . . . . .	34	5.6.1	Cleaning the brushes . . . . .	59
2.2.3 Battery type . . . . .	15	3.2.1 Left-hand operating panel . . . . .	34	5.6.2	Changing the brushes . . . . .	59
2.2.4 Installing the trough battery . . . . .	15	3.2.2 Right-hand operating panel . . . . .	36			
2.2.5 Installing the driving/block battery . . . . .	16	3.2.3 On the vehicle . . . . .	42			
2.2.6 Checking the battery plugs . . . . .	17					
2.2.7 Initial battery charge . . . . .	17					
2.3 Cleaning operation . . . . .	18					
2.3.1 Check the battery charge . . . . .	19					

## Table of Contents



5.7	Cylindrical brush head . . . . .	60
5.7.1	Emptying the dirt hopper . . .	61
5.7.2	Disassembling the brushes .	61
5.7.3	Installing the brushes . . . . .	61
5.8	Deflector . . . . .	62
5.8.1	Pivoting the deflector away .	62
5.8.2	Changing the deflector rubber . . . . .	62
5.9	Squeegee . . . . .	63
5.9.1	Cleaning the squeegee . . . .	64
5.9.2	Changing the sealing strips .	64
5.9.3	Adjusting the sealing strips .	65
	<b>Minuteman International Made Simple Commercial Limited Warranty.....</b>	<b>68</b>
	<b>Minuteman International Made Simple Commercial Limited Warranty.....</b>	<b>69</b>

## Safety Information

### 1 Safety Information

#### 1.1 Safety and warning labels

All information related to personal safety, safety of the vehicle and environmental protection are assigned the following symbols throughout the operating manual:

Symbol	Hazardous for...	Definition
Danger 	persons or property	Safety information to prevent the development of hazardous situations resulting from ignoring or failing to follow instructions or prescribed work procedures.
Note 	the equipment	Important information on handling the equipment in order to maintain its functionality.
Ecological hazard 	the environment	Ecological hazard through the use of substances which represent a potential hazard to health and the environment.

## Safety Information

### 1.2 General information

- In addition to the information provided in this operating manual, all the legally applicable health and safety provisions must be observed.
- Before starting up the vehicle for the first time, read the operating manual supplied with it thoroughly as well as any separate operating manuals provided with additional or attachment devices and observe all the information during work.
- The vehicle may only be operated, serviced and repaired by personnel trained by Minuteman technical experts.
- This vehicle is not intended to be used by persons (including children) with limited physical or mental capabilities or persons without sufficient experience and ability.
- Particular attention should be paid to the information regarding safety. Technical expertise is the key to preventing errors when operating the equipment and ensuring trouble-free operation.
- The operating manual must always be kept at the operating location of the vehicle and, as a result, should

- kept in a safe place on the vehicle.
- If the equipment is sold or rented out, these documents should be transferred to the new owner/operator. The transfer should be confirmed!
- The warning labels attached to the equipment provide important information concerning safe operation. Labels which are illegible or missing must be replaced.
- Original spare parts must be used to ensure safety.
- It is forbidden to remain in the hazard area represented by the vehicle.

### 1.3 Operating information

- Before starting the vehicle up for the first time, the battery to be used must be fully charged, properly, by implementing the initial battery charge routine. Please pay attention to the operating manual provided with the charging unit as well as the manual from the battery manufacturer. Minuteman assumes no liability for damage to the battery caused by a fault when the battery is charged for the first time.
- Check the operational safety of the machine each time before starting it up! Clear any faults immediately.
- Before starting work, the operator must be fully familiar with all adjustment, operating and control elements as well as their respective function! It is too late to do this when the machine is actually in operation!
- Always wear heavy duty, non-slip footwear when working with the machine.
- The machine may only be driven on and the equipment used on those surfaces which have been approved by the contractor or person appointed by him.

## Safety Information

- When using the vehicle, it is essential to pay attention to third parties, especially children.
  - Start driving immediately after switching on the brush head drive otherwise the brush could produce impression marks on the floor. Always raise the brush head before driving over thresholds.
  - Only use cleaning agents suitable for the vendor (non-foaming) and observe all the use, disposal and warning information provided by the cleaning agent manufacturer.
  - The vehicle is not suitable for clearing up health-hazardous, inflammable or explosive fluids, dust or substances. Burning or smoldering items, e.g. glowing cigarettes, must not be swept up. It is also forbidden to sweep up wood dusts, e.g. beech or oak dust. Health hazard!
  - For safety reasons, the driver's seat is equipped with a seat contact switch. The vehicle can only be started when the operator is sitting on the driver's seat. The function of the seat contact switch must not be bypassed.
  - It is forbidden to use the machine in potentially explosive atmospheres.
  - It is forbidden to transport persons or heavy objects.
  - It is forbidden to tow machines or operate as a trailer.
  - Remove the key to prevent unauthorized use of the vehicle.
  - When driving the vehicle to the area of use, the squeegee and brush head must be raised. The style of driving must be adapted to the local conditions.
  - Drive slowly on wet ground due to the risk of skidding, particularly when cornering. Drive especially slowly when cornering while driving downhill.
  - The vehicle may only be used on surfaces with a maximum gradient of 10%.
  - It is forbidden to manipulate switches and safety equipment.
- ### 1.4 Maintenance information
- Operating personnel must complete the necessary daily and weekly maintenance work. All other maintenance work must be completed at your nearest authorized Minuteman service center.
  - The maintenance work and maintenance intervals prescribed in the operating manual must be adhered to.
  - Suitable tools must be used for cleaning and maintenance work.
  - The vehicle must be inspected by a recognized technical expert in respect of operational safety, within the terms of the applicable accident prevention laws, at reasonable intervals (we recommend at least once a year) and following modification or repairs.
  - Spare parts must comply with the minimum technical requirements stipulated by the manufacturer! This is ensured by the use of original spare parts.
  - The vehicle and motors must be switched off prior to cleaning or servicing it or to replacing parts.
  - Remove the ignition key to prevent unauthorized use of the vehicle.



## Safety Information

- Always disconnect the battery connectors before starting any work on the electrical installation.
- It is not permitted to clean the machine with a pressure washer or steam blaster.
- It is not permitted to use aggressive and corrosive cleaning agents.
- Allow the vehicle to dry after being cleaned, e.g. over the weekend.
- Only start the vehicle up when all the safety equipment has been installed and brought to its protecting position.
- When working in the area of the raised recovery tank, it must be opened fully to prevent it accidentally slamming shut.

### 1.5 Particular risks

#### Electronics

- In the case of defects in the electrical installation, always switch the vehicle off and clear the fault.
- Work on the electrical installation may only be carried out by electricians who have received the necessary training and in accordance with the electrical engineering regulations.
- The vehicle's electrical installation must be inspected/checked at regular intervals. Defects, such as loose connections, loose nuts on conductive bolts, electrical components and damaged cable, must be rectified immediately.
- Only use original fuses with the specified amperage. The use of fuses with too high a rating could damage the electrical installation beyond repair and could be the cause of fires.

#### Batteries

- Observe the information in the operating manual provided by the battery manufacturer.
- Batteries must not be connected or disconnected when live.
- Always disconnect the battery cable before starting any work on the electrical installation.
- Batteries may only be handled and changed by properly skilled maintenance personnel.
- Due to a change in the center of gravity, only approved batteries may be installed at the intended position.
- Pay attention that the insulation on the charger cable is not initially damaged and not damaged during the charging process. The cable must not rub against anything. Do not use the on-board charger if the insulation is damaged.
- To prevent creeping currents, always keep the batteries clean and dry and protect from contamination, e.g. from metal dust.
- Never lay any metallic objects or tools on batteries. Risk of short circuit and deflagration!
- Ensure sufficient ventilation in the

## Safety Information

charging area when charging the batteries. Otherwise there is a risk of explosion!

- Wash you hands thoroughly after handling batteries.
- It is forbidden to eat, drink and smoke in battery charging rooms.
- For further safety information, see supplementary sheet 88-60-2556 - Notes on driving batteries.

### Information on the power plug

- Only take hold of the power plug and power cable when your hands are dry.
- Never insert the power plug in the socket if the base is wet or damp.
- Never immerse the power cable or power plug in water or other fluids clean them in running water. Risk of electric shock!
- Dry any power plugs and power cables which have become damp with a dry cloth before connecting them in power sockets.
- Pay attention that the power socket is dry.
- We recommended the use of splash-proof power sockets complying with DIN VDE 0620-1.

- Pay attention that no water or fluids can get on to live machine parts. If water should penetrate to such parts, disconnect the power plug immediately and have the vehicle checked at an authorized Minute-man service center.
- The power connection cable must be inspected for signs of damage at regular intervals. If damage is detected, the cable must be replace prior to further use.

### Safety equipment

- Never operate the ERide 30 without the cover being closed and locked.

### 1.6 Environmental protection

- A certain factual expertise is required in order to use substances which could represent a risk to health and the environment.
- Always observe the applicable legal regulations and local directives when disposing of refuse, waste water and cleaning agents, also refer to the German Water Resources Act (WHG).
- Used batteries with the recycling symbol must not be disposed of in household waste, refer to Section "Disposal".

## Safety Information

### 1.7 Labels on the vehicle

The following safety and warning labels are attached to the vehicle where easily legible. Missing or illegible labels must be replaced immediately.

Company logo (Fig. 1/1),(Fig. 2/1)

**Minuteman**<sup>®</sup>

Machine model (Fig. 1/2)

**ERide 30**

Rating plate (Fig. 1/3)



Label: Waste water drainage (Fig. 1/4)



Label: Clean water drainage (Fig. 1/5)



Label: Working width (Fig. 1/6)

XXX/XX

Label: Do not step on deflectors! (Fig. 1/7)



Label: Water overflow! (Fig. 2/8)

ACHTUNG | Überlaufendes Wasser | Verschluss nur bei leerem Tank öffnen!  
CAUTION | Water overflow | Open seal only when tank is empty!  
ATTENTION | L'eau déborde | Ouvrir le bouchon seulement lorsque le réservoir est vide!

Label: Explosive gases (Fig. 2/9)

ACHTUNG : Explosive Gase - Flammen und Funken vermeiden - Während des Ladens für ausreichende Belüftung sorgen.  
Caution: Explosive gases - Avoid fires and sparks - Provide for sufficient ventilation during loading!  
Précaution: Gaz explosifs - Éviter des flammes et étincelles - Pourvoir suffisante ventilation pendant chargement!

Read and observe the operating manual (Fig. 2/10)



Label: Water temperature, max. 50° (Fig. 2/11)



## Safety Information

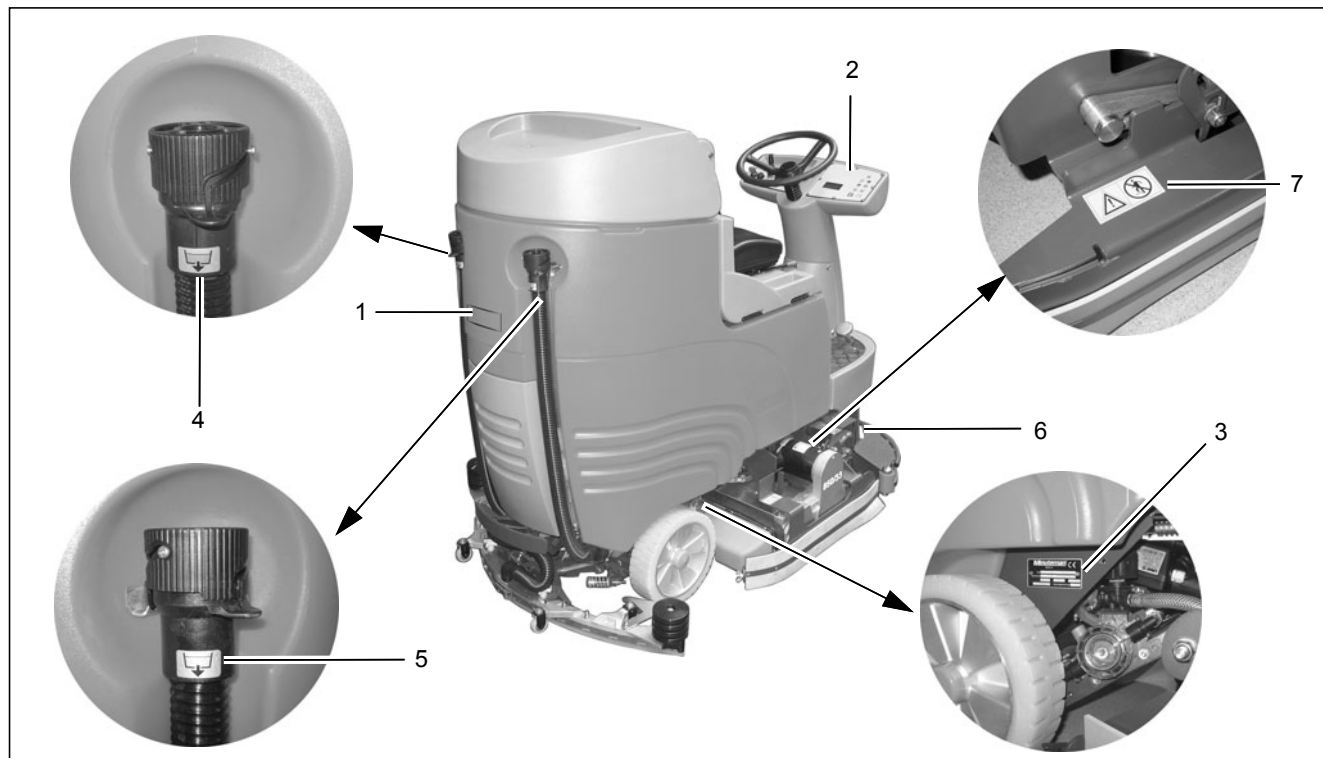

**Fig.1**

## Safety Information

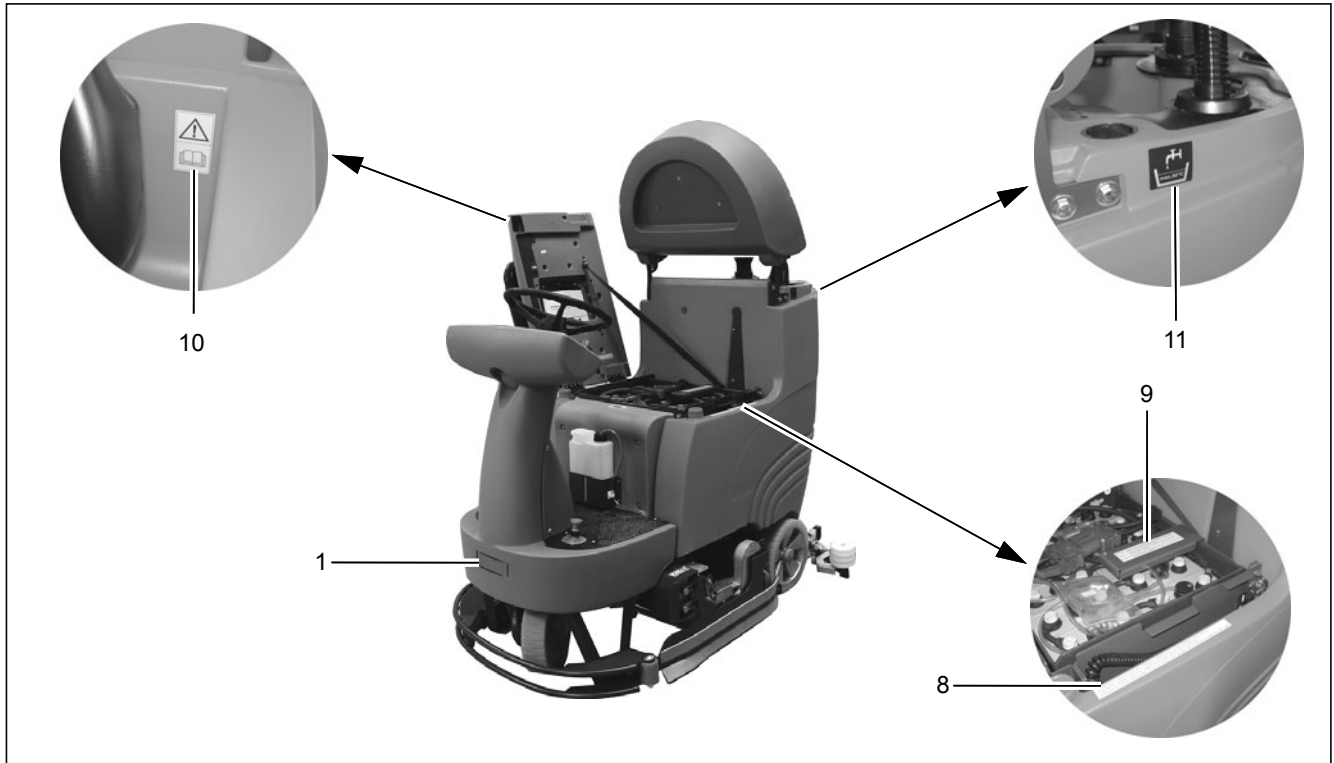

Fig.2

### 2 Operation

#### 2.1 Unpacking

Remove the packaging and take the ERide 30 from the pallet after loosening the tightening straps.

#### 2.2 Prior to starting up for the first time

##### 2.2.1 Instruction

Operators must receive instruction before the vehicle is put into service. Only technicians from your local authorized Minuteman dealer are allowed to provide initial instruction on the machine. The manufacturing plant will notify the dealer immediately after delivering the vehicle and the dealer will contact you to arrange a date.

##### 2.2.2 Assembling the squeegee

1. Use the star-shaped knobs (Fig. 3/1) to fix the squeegee on the squeegee lift (Fig. 3/2).
2. Connect the suction hose (Fig. 3/3) to the nozzle (Fig. 3/4).

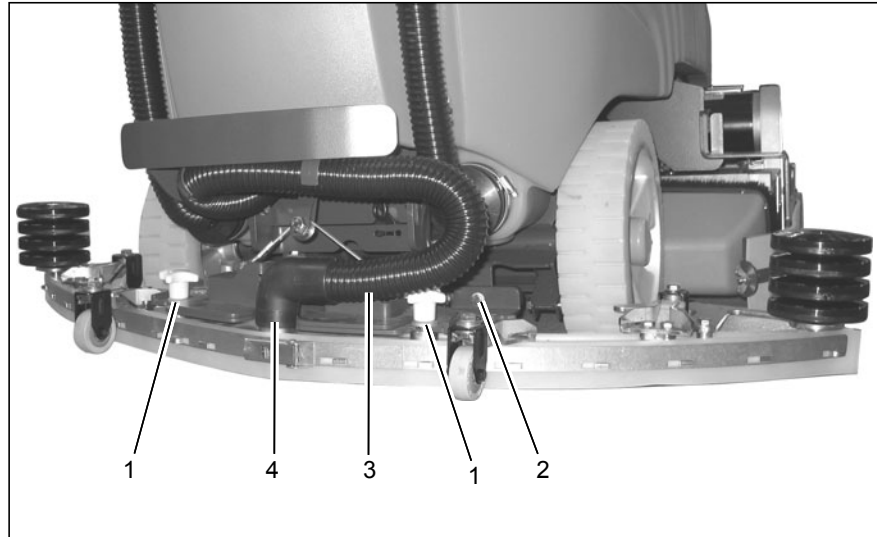

Fig.3

## Operation

### 2.2.3 Battery type

Only batteries approved by Minuteman may be used. The settings can only be made at an authorized Minuteman service center!

### 2.2.4 Installing the trough battery

1. Switch off the vehicle with the key switch.
2. Open the seat console (Fig. 4/1).
3. Install the battery (Fig. 4/2) in the battery trough accordance with illustration.



Replacing/Installing is only possible with the aid of a crane and appropriate lifting gear. Please read the information provided in the operating manual of the battery manufacturer. Trough batteries weigh up to 280 kg. For reasons of safety, we strongly recommend having this work completed at an authorized Minuteman service center.

4. Check the battery plug (Fig. 4/3), refer to Section 2.2.6.

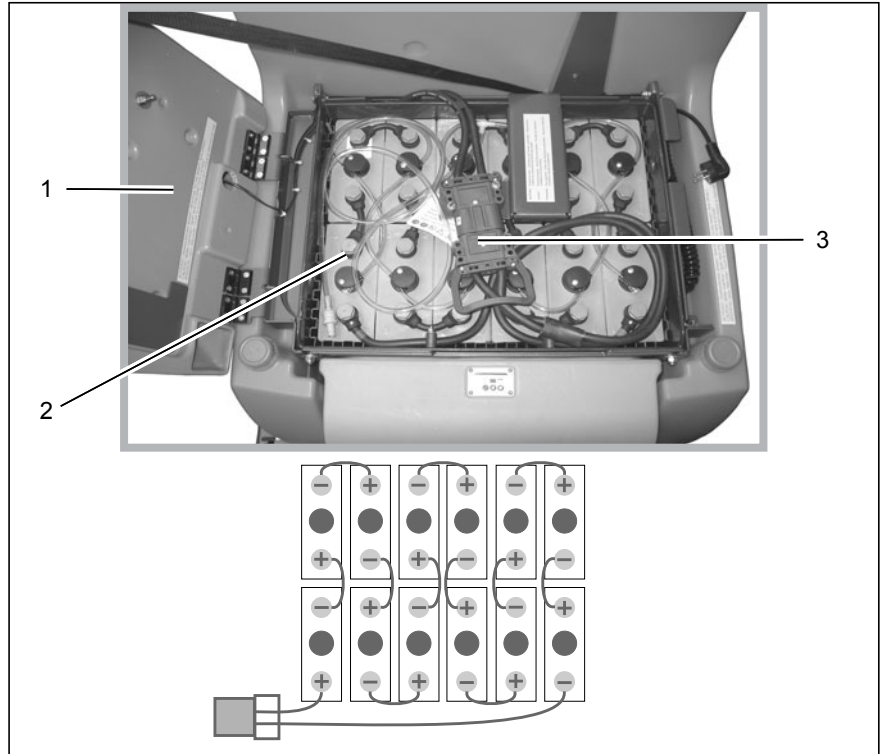

Fig.4

## Operation

### 2.2.5 Installing the driving/block battery

1. Switch off the vehicle with the key switch.
2. Open the seat console (Fig. 5/1).
3. Position the batteries in the battery tray in accordance with the figure.



Replacing/Installing is only possible with the aid of appropriate lifting gear. Please read the information provided in the operating manual of the battery manufacturer. For reasons of safety, we strongly recommend having this work completed at an authorized Minute-man service center.

4. Connect the battery poles in accordance with the connection diagram (Fig. 5/2).
5. Pay attention they are firmly fixed and grease the poles.
6. Check the battery plug (Fig. 5/3), refer to Section 2.2.6.

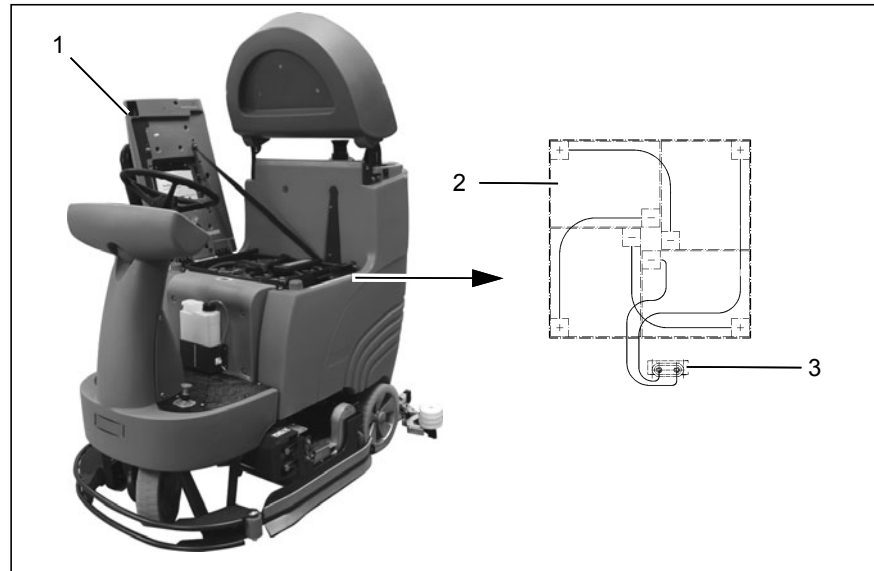

Fig.5



### 2.2.6 Checking the battery plugs

The battery plugs (Fig. 6/1 and 2) on the vehicle, batteries and stationary chargers must be coded with the colored coding pins (Fig. 6/3) according to the battery and nominal voltage. The connectors on the charger are coded at the factory according to the charge characteristic curve so that on changing the charge characteristic curve (according to the battery), the connector coding must be changed.

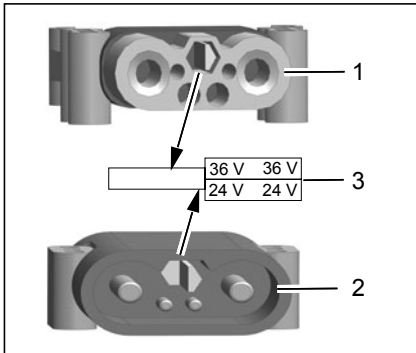

Fig.6

### Connector coding

Socket housing of the battery:

- Gray for wet batteries
- Green for maintenance-free gel batteries

Connector body on the vehicle:

- Yellow for both battery types

### Voltage coding

Insert the coding pin (Fig. 6/3) so that the nominal voltage can be read through the window in the housing. Always select the same nominal voltage for the socket and connector. The following three conditions must be fulfilled for the complete system:

1. The voltage coding must be the same for all connectors and sockets.
2. The color of the coding pin in the vehicle is yellow.
3. The color of the coding pin in the charger connector (vehicles without built-in charger) complies with the battery plug.

### 2.2.7 Initial battery charge



Before starting the vehicle up for the first time, the batteries to be used must be fully charged, properly, by implementing the initial battery charge routine. Please pay attention to the operating manual provided with the charging unit as well as the manual from the battery manufacturer. Minute-man assumes no liability for damage to the battery caused by a fault when the battery is charged for the first time.

## Operation

### 2.3 Cleaning operation



Read and follow the safety information in Chapter 1 before operating the vehicle.

1. Check the parking space for signs of leaks. Hoses, lines and tanks must show no signs of leaks or damage.
2. Check the battery charge, refer to Section 2.3.1.



The current charge status appears in the indicator field. Charge the battery, if necessary, refer to Section 2.3.2.

3. Drain off the waste water tank, refer to Section 2.3.3.



You are informed the waste water tank is full via the indicator field.

4. Fill the clean water tank, refer to Section 2.3.4.



The maximum temperature is 50°C.

5. Adjust the driver's seat, refer to Section 2.3.5.

6. Lock the side deflector.
7. Switch on the vehicle with the key switch and set the required driving direction using the driving direction selection switch, refer to Section 2.3.6.



The operating hour counter displays the software version, the last service code (if applicable) and operating hours in succession. Service code table, refer to Section 2.4

8. Press the button for the brush head and squeegee.



The vehicle is ready for operation.

9. Press the button for the clean water supply.



The clean water supply is activated.

10. Press the button for the clean water dosing.



The clean water quantity is set.

11. If necessary, press the button for brush pressure adjustment.



The brush pressure is activated.



Start driving immediately after switching on the brush head drive otherwise imprints of the brush could be produced on the floor!  
Always raise the brush head before driving over thresholds!

## Operation

### 2.3.1 Check the battery charge

The batteries are charged using the integrated battery charger (Fig. 7/1). The batteries can be charged as soon as the first field in the charge status indicator (Fig. 7/2) goes out, at the latest, however, after the cleaning functions have switched off (all fields go out).

### 2.3.2 Charging the battery

1. Move the vehicle to a piece of level ground and switch it off.
2. Open the seat console and connect the battery charger to the power outlet using the power cable (Fig. 7/3).



The seat console (Fig. 7/4) must be open during the charging process!



Never let batteries stand around in a discharged state but recharge them immediately!

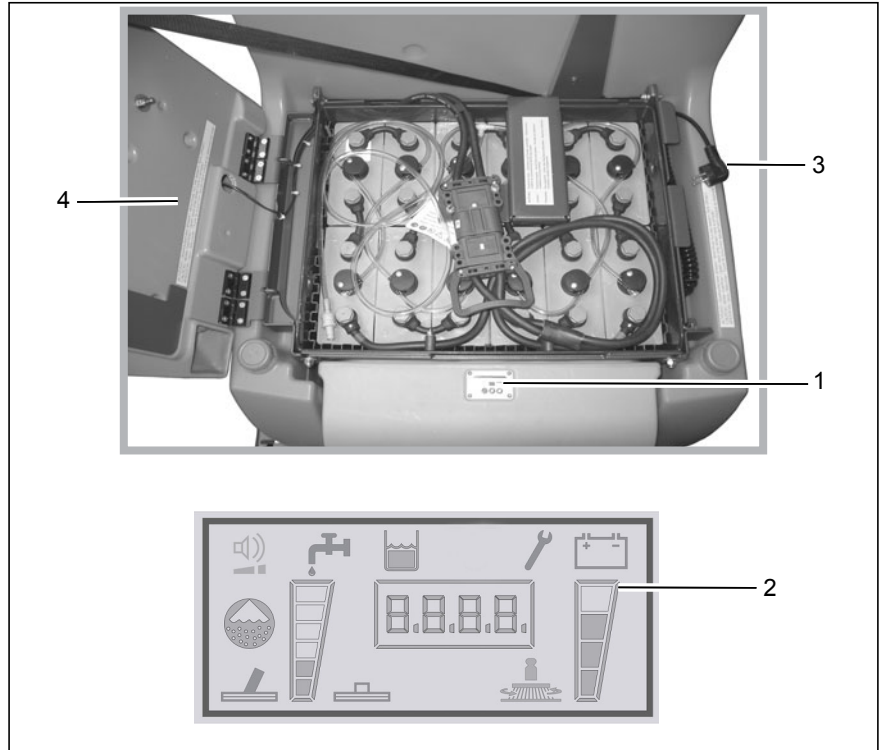

Fig.7

## Operation

### Checking the charging process

You can monitor the charging process by means of the LED on the integrated charger. When the charging process is started (by connecting the power plug or battery connection), the green LED flashes (according to the characteristic curve set). While the charging program is active, the yellow LED (Fig. 8/1) lights up. When the charging program has ended, the green LED (Fig. 8/2) lights up. A trickle charge is then supplied. The battery is again ready for use. The vehicle cannot be switched on while the integrated charger is in operation!

The red LED (Fig. 8/3) signals an error.

- Invalid characteristic curve - red LED flashes fast
- Battery error (no battery, charging time exceeded) - red LED flashes slowly
- Device too hot - red LED lights up (error is not automatically reset)

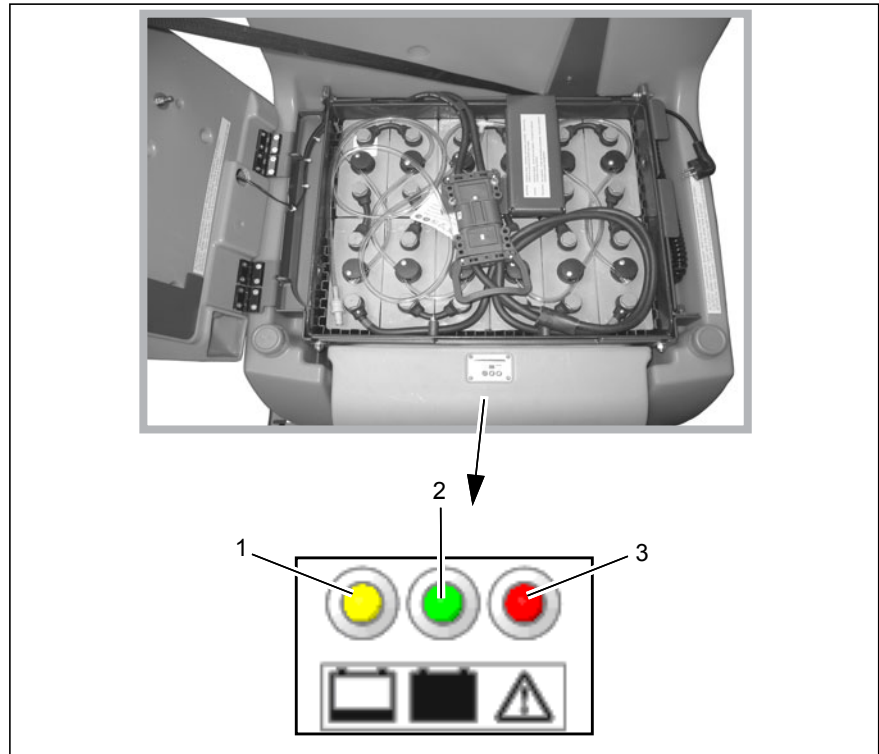

Fig.8

## Operation

### 2.3.3 Emptying the waste water tank

Empty the waste water tank (Fig. 9/1) daily, as necessary or following the acoustic warning and indicator in the display.

1. Drive to an appropriate disposal point.
2. Park the vehicle so that the draining hose (Fig. 9/2) reaches the drain in the floor.
3. Switch off the vehicle.



Observe the applicable laws and local regulations when disposing of cleaning agents!

4. Remove the draining hose from the holder and open the plug (Fig. 9/3) by turning it 90° counterclockwise. Empty the waste water tank completely.

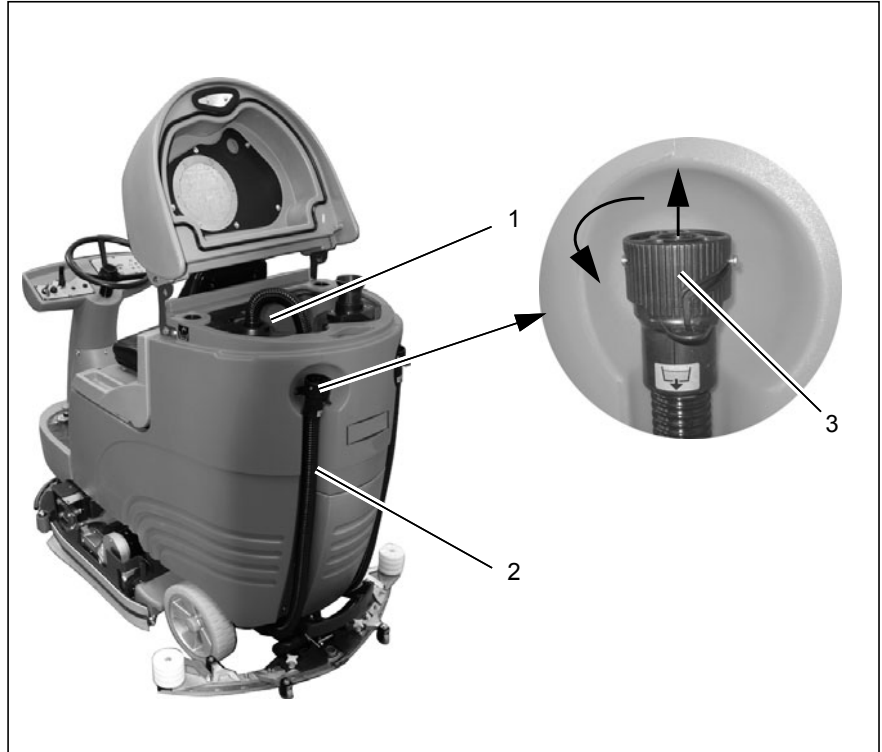

Fig.9

## Operation

### 2.3.4 Filling the clean water tank

1. Fill the clean water tank (Fig. 10/1) before starting work or as necessary. Park the vehicle on a level floor area.
2. Open the tank cap (Fig. 10/2) and fill the clean water tank through the opening (Fig. 10/3) (max. temperature 50°C).
3. Mix the cleaning agent in accordance with the manufacturer's instructions.



Only use cleaning agents approved by Minuteman for their vendors (non-foaming). These products meet the requirements stipulated in the washing and cleaning agent directive (WRMG - Wasch- und Reinigungsmittelgesetzes).

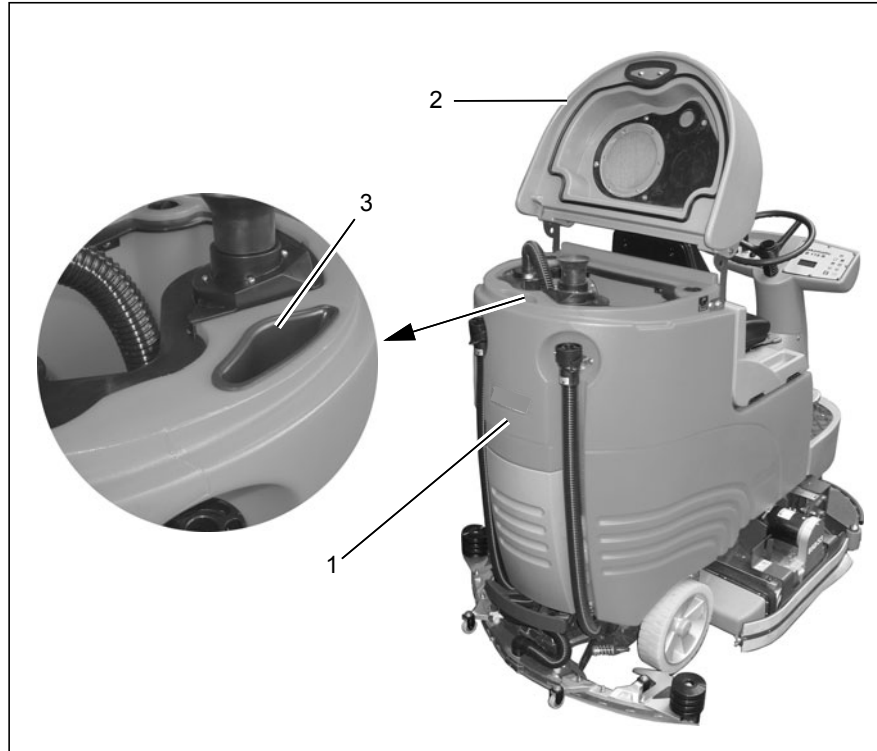

Fig.10

### 2.3.5 Adjusting the driver's seat

The driver's seat (Fig. 11/1) can be adjusted with the lever (Fig. 11/2) so that the driver can sit comfortably with all the operating elements within easy reach.



The vehicle is equipped with an electronically monitored seat contact switch. Damage or manipulation of the seat contact switch causes the vehicle to be locked against use.



**Fig.11**

## Operation

### 2.3.6 Switching the vehicle on



For safety reasons, the driver's seat is equipped with a seat contact switch. The vehicle can only be started when the operator is sitting on the driver's seat.



The drive can only be started when the accelerator pedal is not being actuated.

1. Pull the power plug (Fig. 12/1) from the socket and place it in the holding recess.
2. All control levers must be in their neutral position.
3. Switch on the vehicle with the key switch (Fig. 12/3) and set the required direction using the driving direction selection switch (Fig. 12/5). The operating hour counter (Fig. 12/4) displays the software version, the last service code (if applicable) and operating hours in succession. Service code table, refer to Section 2.4.
4. Actuate the accelerator.

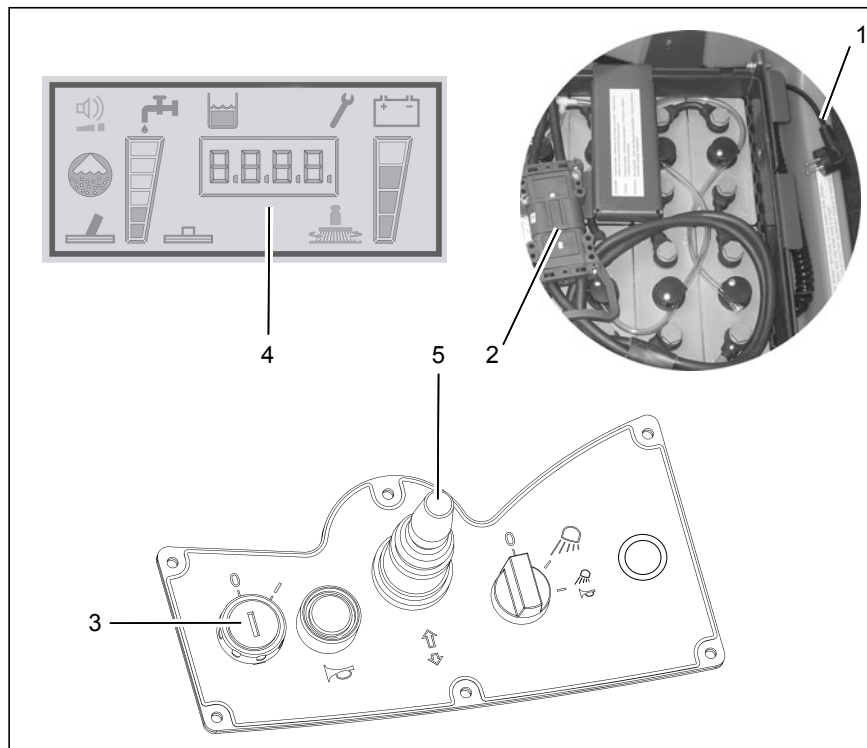

Fig.12



## Operation

### 2.3.7 Driving and braking behavior



To switch off all functions immediately, turn the key switch to '0'.

Pay attention to the following points when driving:

- The driving speed and deceleration of the vehicle are controlled by the accelerator.
- On releasing the accelerator, the engine brake is automatically applied. This also applies when driving up and down gradients.
- Stop the vehicle: Release your foot from the accelerator
- When the vehicle has come to a halt, the parking brake is automatically applied. The vehicle cannot then be pushed.

#### Overload protection

In the event of overloading, e.g. too steep a gradient, the hydraulic engine is switched off after a time.

- Allow the engine to cool down for approx. 15 minutes.
- Start the vehicle again.

### 2.3.8 Pushing the vehicle

The vehicle can only be pushed when the Unlocking button (Fig. 2.3.9/1) of the brake is pressed in.

- Set the key switch to "On".
- Press and hold the Unlocking button and, at the same time, push the vehicle.



#### DANGER

When the Unlocking button is pressed in, no braking effect is applied to the vehicle!

The Unlocking button is at the front left of the vehicle (viewed in driving direction) under the chassis.

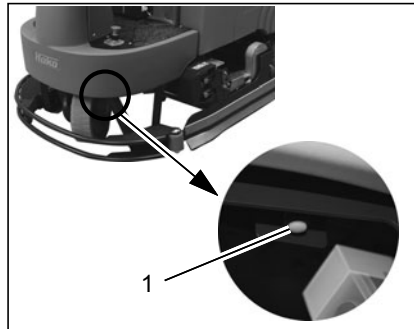

Fig.13

## Operation

### 2.3.9 Charge status indicator

The charge status indicator (Fig. 14/1) provides information on the current charge status of the batteries up to the total discharge limit. If the batteries are fully charged when the vehicle is switched on, all four fields light up under battery icon. While the vehicle is in operation, the fields go out according to the discharge of the battery power. When the top three fields have gone out, the permissible low discharge level is reached. The bottom field begins to flash and an acoustic warning signal is issued. All the cleaning units are switched off after three minutes, the vacuuming function following a 15 second rundown time. The vehicle can then be driven at reduced driving speed to a charging point for the batteries. For information on charging the batteries, refer to Section 2.3.2



If the vehicle is switched on, an acoustic warning signal continues to be issued. When the battery charging process has been completed, the status is cleared and the vehicle is again ready to operate.

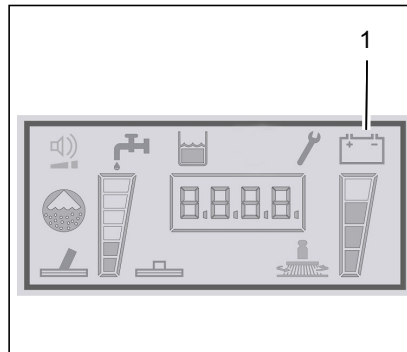

Fig.14

## Operation

### 2.3.10 Switching the vehicle off

1. Release the accelerator (Fig. 15/1) slowly to its zero position. The vehicle slows until it eventually stops. You can decelerate more quickly by applying the vehicle's brake (Fig. 15/3).
2. Move the driving direction selector switch (Fig. 15/2) to its zero position.
3. Switch off the clean function.
4. Switch the vehicle off with the key switch (Fig. 15/4).



Remove the ignition key when getting off the vehicle to prevent unauthorized use.

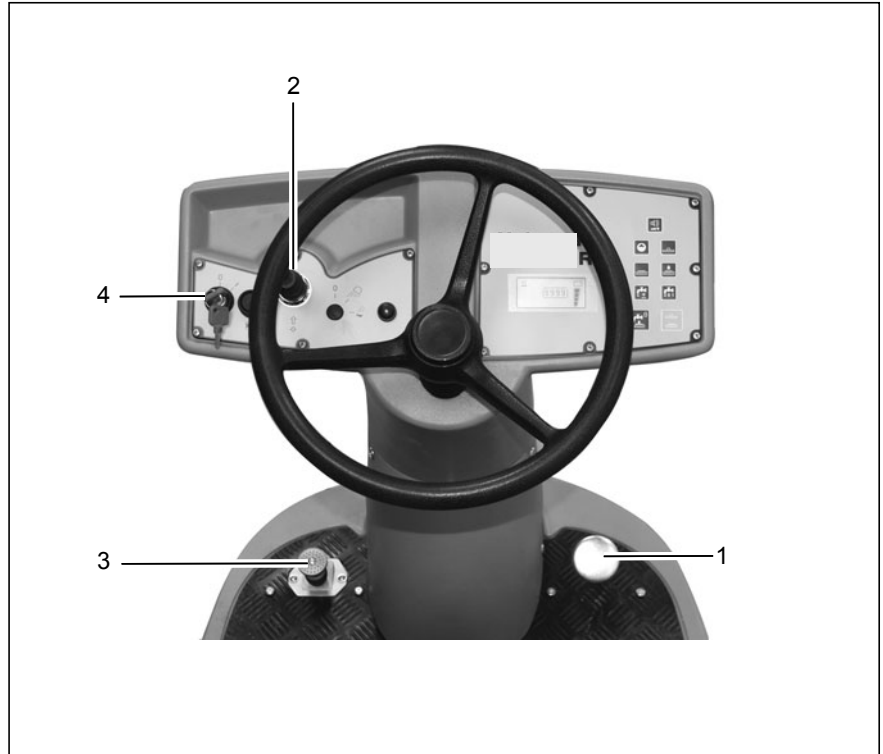

Fig.15

## Operation

### 2.3.11 After completing cleaning

1. Drive to an appropriate maintenance area.
2. Stop the vehicle, raise the brush head and squeegee and remove the key.
3. Empty the waste water tank and flush it.



Observe the applicable laws and local regulations when disposing of cleaning agents.

4. Check the clean water filter (Fig. 16/1).
5. Check the sealing strips (Fig. 16/2) and suction hose (Fig. 16/3).
6. Check the electrical equipment, functions and settings.
7. For information on charging the battery, refer to Section 2.3.1
8. Clean the machine. If the machine is to be shutdown for a longer period, the clean water tank must be emptied.



It is not permitted to clean the vehicle with a pressure washer or steam blaster.

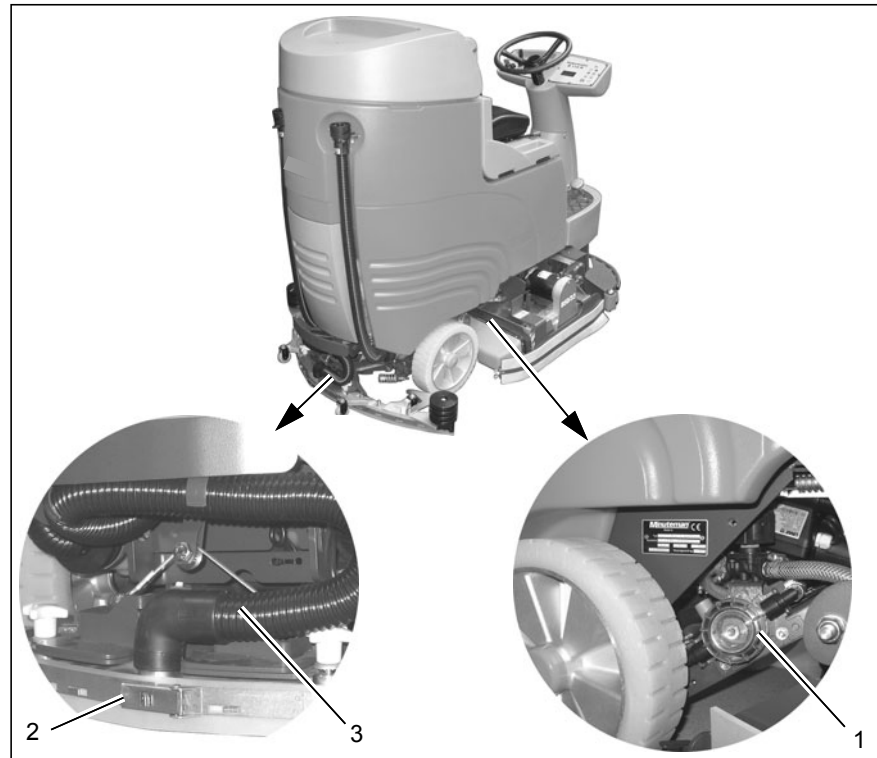

Fig.16

## Operation

### 2.4 Service code table

In the case of system errors, a four-digit error code appears in the operating panel in addition to the service indicator (wrench symbol).

The dots in the service code flash.

Clear the fault or note down the service

code and inform your authorized Minuteman dealer.

When the cause is cleared, the error must finally be acknowledged by turning the key switch OFF/ON.

Code	Fault	Cause	Solution
1.2.5.2.	Brushes stop	Foreign bodies between brush and shaft	<ul style="list-style-type: none"> <li>• Check the brushes for foreign bodies and remove them, as necessary.</li> </ul>
1.2.6.1.	Brushes stop	Foreign bodies block the brush	<ul style="list-style-type: none"> <li>• Check the brushes for foreign bodies and remove them, as necessary.</li> </ul>
1.2.6.3.	Brush attachment and brush motor are switched off	Foreign bodies between the brush head and vehicle.	<ul style="list-style-type: none"> <li>• Check the brush head for foreign bodies and remove them, as necessary.</li> </ul>
1.4.6.1.	Squeegee lift and suction turbine are switched off	<ul style="list-style-type: none"> <li>• Foreign bodies between the squeegee and vehicle.</li> <li>• Squeegee is jammed</li> </ul>	<ul style="list-style-type: none"> <li>• Check the holding attachment for foreign bodies and remove them, as necessary.</li> <li>• Free the squeegee.</li> </ul>
3.3.1.1.	Service interval has expired	Refer to maintenance schedule	
3.4.5.1.	Cleaning function is switched off	<ul style="list-style-type: none"> <li>• Foreign bodies are interfering with the drive chain or drive wheels</li> </ul>	<ul style="list-style-type: none"> <li>• Remove the foreign bodies</li> </ul>

## Operation

### 2.5 Loading and transporting



When the vehicle is loaded for transport or driven to its point of use, the squeegee and brush head must be raised.

#### **Loading**

Take the weight of the vehicle into account when loading it, refer to Section "Technical Data".

#### **Transporting**

When the vehicle is to be transported on another vehicle or trailer, it must be secured against rolling away. Lash the machine down securely. Fix the vehicle in place with lashing straps.

## Operation

### 2.6 Special equipment and accessories

Refer to the table below for the order numbers of the special equipment and accessory parts.



Only the special equipment and accessory parts listed here may be used. Please contact the authorized Minuteman dealer responsible for you.

Special equipment for ERide 30	Order no.
Warning equipment with flashing light and acoustic signal	7091
Working lights	7092
Comfort seat	7093
Mop holder and toolkit net for cleaning tools	7095
Large particle sieve for waste water tank	7060
Large particle sieve for clean water tank	7679
On-board chemical dosing system	767845
Tool connection (not available with On-board dosing system)	737602
Vacuuming and spraying hose	7766
Floor scrubbing and vacuuming tool	7009

## Operation

<b>Accessories for disk brushes</b>	<b>Pcs.</b>	<b>TB 650</b>	<b>TB 750</b>	<b>TB 900</b>
Light to medium soiling - PPN 0.5	2	7513	7514	7544
Light to medium soiling, structured floors - K901	2	7517	7518	7547
Light to medium soiling, structured floors - SIC PA 600	2			7317
Medium to heavy soiling - PPN 0.8	2	7515	7516	7543
Medium to heavy soiling - SIC PA 6/600	2	730702	7308	
Very heavy soiling / basic cleaning, SIC PA 6/180	2	7519	7520	7545
Extremely heavy soiling / basic cleaning, SIC PA 6.12/120	2	7521	7522	7546
Specially for use on structured multi-storey car park floors	2		7684	7686

<b>Accessories for super-pads with drive plates</b>	<b>Pcs.</b>	<b>TB 650</b>	<b>TB 750</b>	<b>TB 900</b>
Light soiling - red	5	752505	752605	755105
Routine cleaning - brown	5	752705	752805	754905
Basic cleaning and heavy soiling - black	5	752905	753005	755005
Medium soiling and routine cleaning - green	5	787105	787205	787405
Poly pads (microfiber pads)	2	708502	708602	708802
Also necessary: drive plates (pad holders) with center lock	2	7523	7524	7548

<b>Accessories for cylindrical brushes</b>	<b>Pcs.</b>	<b>WZB 600</b>	<b>WZB 700</b>	<b>WZB 850</b>
Light to medium - PA 6/0.7 mm	1	7021	7096	7681
Medium to heavy, structured floors - SIC PA 6.12/500	1	7022	7099	7682
Very heavy soiling / basic cleaning - SIC PA 6.12/180	1	7023	7094	7683



## 3 Operation

### 3.1 Method of operation

The ERide 30 is a scrubber-drier for the wet cleaning of hard floors.



The vehicle can be supplied fitted with a disk brush head or cylindrical brush head. This manual contains illustrations of both versions.

When a cleaning operation is activated, cleaning agent is fed from the clean water tank (Fig. 17/1) to the rotating brushes on the brush head (Fig. 17/2). As the vehicle is driving forwards, the cleaning solution applied to the brushes and floor is vacuumed up by means of the squeegee (Fig. 17/3) and fed to the waste water tank (Fig. 17/4).

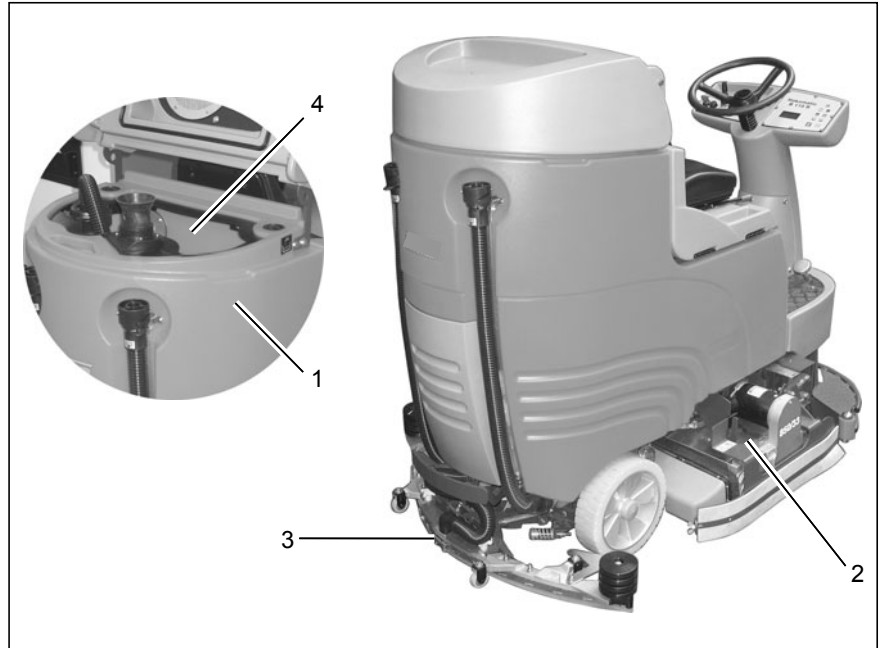

**Fig.17**

## Operation

### 3.2 Operating and indicator elements

#### 3.2.1 Left-hand operating panel

- 1 Key switch
- 2 Horn button
- 3 Driving direction selection switch
- 4 Switch for working lights or hazard warning system (option)
- 5 Scrubbing-vacuum tool (option)

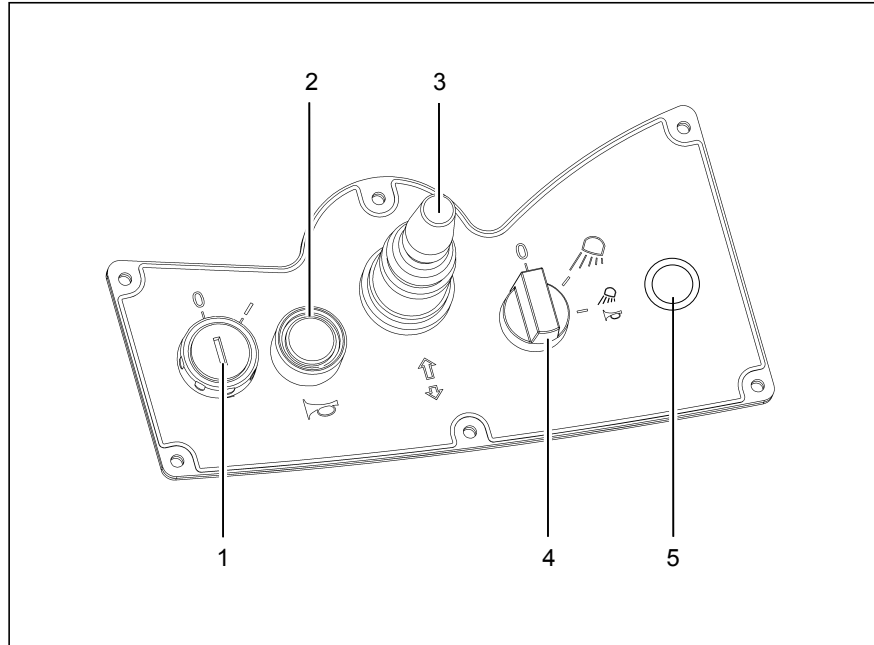

Fig.18

## Operation



### Key switch (Fig. 18/1)

It serves to switch the electrical system on and off and to secure the vehicle against unauthorized use. (When switched on, the operating hour counter also appears in the display.) When the switch is set to OFF, all the switching functions are returned to their original state (reset).



### Horn button (Fig. 18/2)

It serves to sound the horn



### Driving direction selection switch (Fig. 18/3)

It serves to select the driving direction:

- Control forward = forward drive
- Control lever O = neutral position
- Control lever back = reverse drive

To change the driving direction, stop the vehicle by applying the accelerator pedal, select the new direction and accelerate again.



### Switch for working lights or hazard warning system (option) (Fig. 18/4)

It serves to switch the buzzer and warning light on and off, as well as to switch the working lights on and off. Function is also possible without the key switch. (Warning light / Working lights are options).



### Scrubbing-vacuum tool (option) (Fig. 18/5)

This serves to activate the manual floor scrubbing and vacuuming tool. The function is can only be activated when the accelerator is not pressed and the driver is not seated in the driver's seat

## Operation

### 3.2.2 Right-hand operating panel

- 1 Indicator field
- 2 Button, silence kit
- 3 Button, chemical dosage (option)
- 4 Button, squeegee and suction turbine
- 5 Button, brush drive
- 6 Button, brush pressure adjustment
- 7 Button, clean water dosing
- 8 Button, clean water supply
- 9 Button, boost function
- 10 Button, brush head and squeegee (Automatic button)

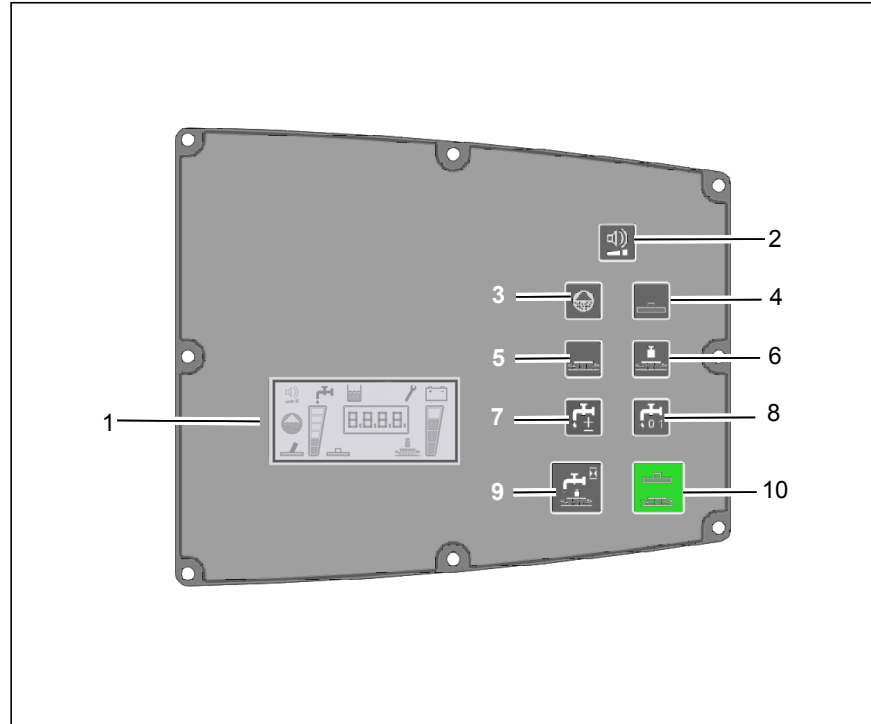

Fig.19

## Operation

### Indicator field (Fig. 19/1)

The indicator field provides a central function monitoring facility and indicates all operating states.



### Button for silent kit (Fig. 19/2)

This button is used to switch the suction turbine to Silent mode. The Silent mode icon appears in the indicator field.



### Button for chemical dosage (option) (Fig. 19/3)

This button is used to switch on the chemical dosage. The chemical dosage icon appears in the indicator field.



### Button for squeegee and suction turbine (Fig. 19/4)

The button is used to lower/raise the squeegee and switch the suction turbine on/off. After the suction turbine is switched off:

- the squeegee is raised after a delay
- the suction turbine is shutdown after a delay.



### Button for brush drive (Fig. 19/5)

This button is used to switch the drive and water supply on/off and simultaneously lower the brush head.



### Button for brush pressure adjustment (Fig. 19/6)

The button is used to increase the brush pressure if this is necessary due to the degree of soiling.



### Button for clean water dosage (Fig. 19/7)

This button is used to regulate the quantity of clean water. In addition, the quantity of water is adapted to the driving speed. The clean water quantity being supplied is displayed in the indicator field by a six-section icon.



### Button for clean water supply (Fig. 19/8)

This button is used to switch the clean water supply on and off.

## Operation



### **Button for boost function (Fig. 19/9)**

The boost function only works in combination with the Automatic button. The maximum water supply and full brush pressure are activated as long as the Boost button remains pressed. The icons for scrubbing (Fig. 20/10), suction turbine operation (Fig. 20/8), solution dosing level 6 (Fig. 20/2) and the icon for brush pressure adjustment (Fig. 20/11) flash in the indicator field. After releasing the button the machine automatically switches back to the operating mode in which the machine was running before the Boost function was activated.

Conditions for the boost function:

- charge status of the battery is ok,
- suction turbine has not been deactivated by the float switch,
- Automatic button is activated.



### **Button for brush head and squeegee (Automatic button) (Fig. 19/10)**

The Automatic button serves to switch the brush drive and suction turbine on/off with simultaneous lowering/raising of the brush head and squeegee, respectively. The water quantity last selected is supplied.

## Operation

### Indicator field

- 1 Icon, silent kit
- 2 Icon, clean water dosage
- 3 Icon, waste water tank full
- 4 Icon, service indicator
- 5 Icon, charge status indicator (TSG)
- 6 Icon, chemical dosage (option)
- 7 Icon, scrubbing-vacuum tool
- 8 Icon, suction turbine drive
- 9 Icon, operating hour counter
- 10 Icon, scrubbing
- 11 Icon, brush pressure adjustment

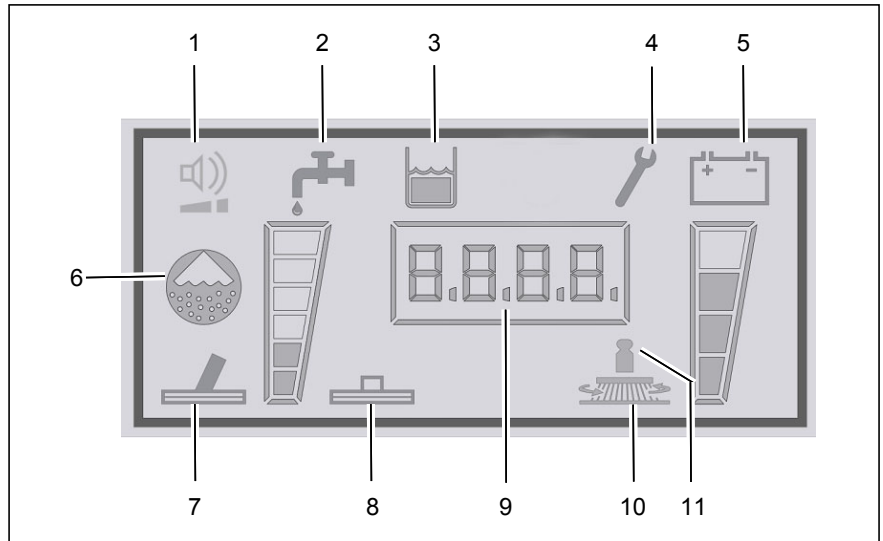

**Fig.20**

## Operation



### Icon, silent kit (Fig. 20/1)

The icon appears when the option has been activated. The right-hand, lower bar goes out when the function is switched on via the button.



### Icon, clean water dosage (Fig. 20/2)

The icon appears when the clean water supply button has been actuated and the brush head is lowered.



### Icon, waste water tank full (Fig. 20/3)

The icon appears when the waste water tank is full. Emptying the waste water tank, refer to Section 2.3.3.



### Icon, service indicator (Fig. 20/4)

The service indicator lights up when an error has occurred in the system and the cleaning or driving process has been interrupted. In addition to the service indicator, a four-digit service code appears in the display of the operating hour counter.

Please note down the service code and notify the authorized Minuteman dealer responsible for you.



### Icon, charge status indicator (Fig. 20/5)

After switching the vehicle on, the charge status indicator appears in the display. The current battery charge status is indicated during operation. For further information, refer to Section 2.3.7.



### Icon, chemical dosage (option) (Fig. 20/6)

The icon appears when the chemical dosage (option) is switched on.



## Operation



### **Icon, scrubbing-vacuum tool (option) (Fig. 20/7)**

The icon appears when the scrubbing-vacuum tool button (A) has been switched on. A floor scrubbing and vacuuming tool (option) can be deployed in conjunction with the scrubbing-vacuum function to apply and vacuum up cleaning liquids in areas difficult to access.



### **Icon, suction turbine drive (Fig. 20/8)**

The icon appears when the suction turbine drive has been switched on. The suction turbine continues to run for 15 seconds after the vacuuming function has been switched off. The icon flashes during this period.

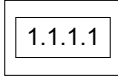

### **Icon, operating hour counter (Fig. 20/9)**

After switching the machine on, the software version and last service code appear briefly in the operating hour counter. The operating hour counter then indicates the number of operating hours currently accumulated.



### **Icon, scrubbing (Fig. 20/10)**

The icon appears when scrubbing mode has been switched on.



### **Icon, brush pressure adjustment (Fig. 20/11)**

The icon appears when brush pressure adjustment has been switched on.

## Operation

### 3.2.3 On the vehicle

- 1 Accelerator
- 2 Brake
- 3 Clean water tank filling neck
- 4 Water filter
- 5 Waste water draining hose
- 6 Clean water draining hose (with water level indicator)

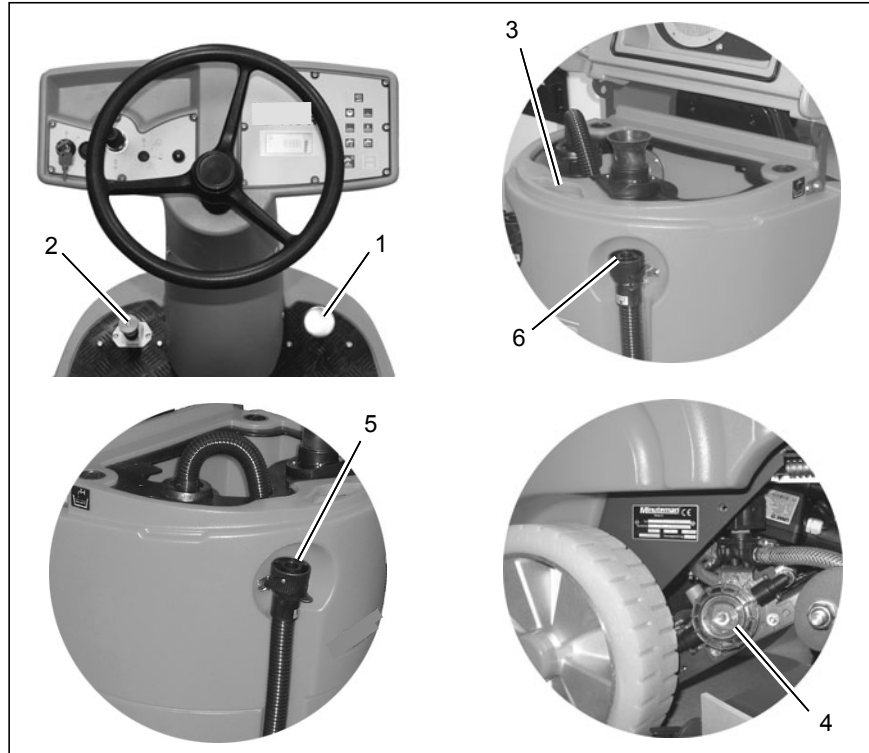

Fig.21

## Operation

### **Accelerator pedal (Fig. 21/1)**

When the vehicle has been switched on, the accelerator is used to control the driving speed in a continuously variable adjustment. An operator must be seated on the driver's seat.

On releasing your foot from the accelerator, the vehicle decelerates and automatically returns to its neutral position.

### **Brake / Parking brake (Fig. 21/2)**

The mechanical brake serves to slow the vehicle down and park the vehicle.

### **Clean water filling neck (Fig. 21/3)**

The clean water tank is filled through a filling neck which can be opened.

### **Clean water filter (Fig. 21/4)**

When the water is fed from the clean water tank to the brush head, the water is cleaned by a filter insert.

### **Waste water draining hose (Fig. 21/5)**

The waste water draining hose is used to drain of the waste water which has been vacuumed up.

### **Clean water draining hose (Fig. 21/6)**

The draining hose is used to drain the clean water tank.

## Operation

### Lever for cylindrical brush support (Fig. 22/1)

This lever is used to lock/unlock the cylindrical brush support. The cylindrical brushes can be disassembled quickly, without the need for tools.

### Dirt hopper, cylindrical brush head (Fig. 22/2)

The cylindrical brush head is provided with a dirt hopper equipped with a lock. The dirt hopper can be removed to be cleaned.

### Ejector for disk brushes (Fig. 22/3)

The brush ejector enables the brushes to be disassembled quickly, without the need of any tools.

### Power connection (Fig. 22/4)

The charger is supplied with power via the power connection.

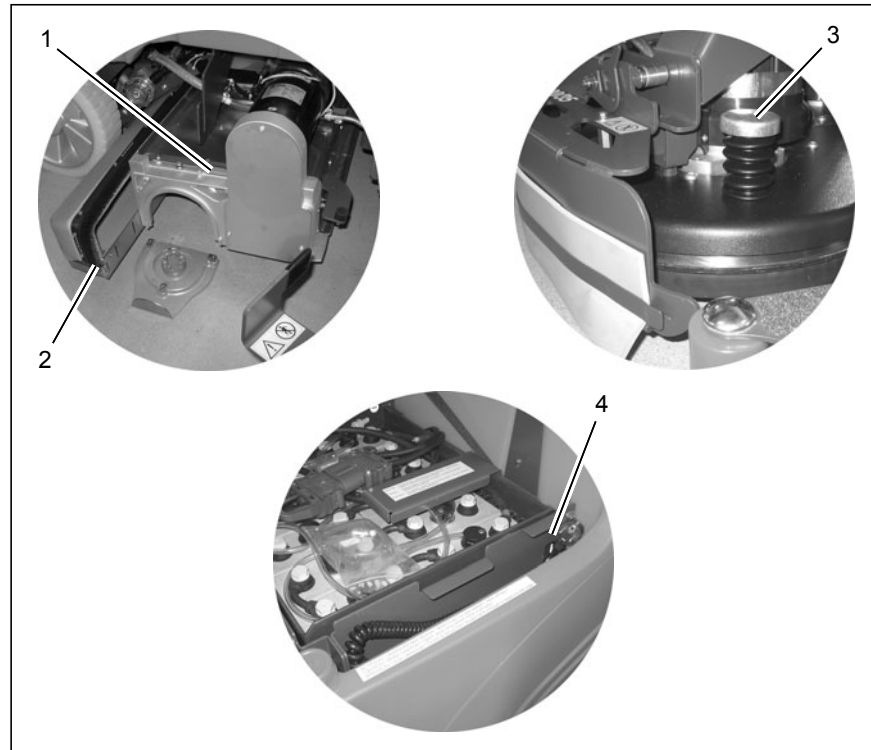

Fig.22

## Technical Data

### 4 Technical Data

	Unit	TB 650	TB 750	TB 900	WZB 700	WZB 850
<b>Dimensions</b>						
Vehicle length, with squeegee	inch	65,4	65,4	65,4	65,4	65,4
Vehicle width, with squeegee	inch	34,1	37,8	44,1	37,8	44,1
Vehicle height	inch	56,7	56,7	56,7	56,7	56,7
<b>Working width</b>						
Brush head	inch	25,6	29,5	35,4	27,6	33,5
Squeegee	inch	34,1	43,3	43,3	43,3	43,3
<b>Weights</b>						
Weight (empty, without batteries)	lb	760,6	760,6	765	760,6	765
Total weight (ready to operate)	lb	1587,3	1587,3	1602,8	1587,3	1602,8
<b>Driving performance</b>						
Driving speed (forwards/reverse)	kph	7.0/3.4	7.0/3.4	7.0/3.4	7.0/3.4	7.0/3.4
Climbing capacity	%	10	10	10	10	10
Ramp angle (straight/inclined)	Degrees	15°/5°	15°/5°	15°/5°	15°/5°	15°/5°
Turning circle	inch	66,9	66,9	70,9	66,9	70,9
<b>Wheels</b>						
Wheels (front/rear)	Type	EUTHAN 80	EUTHAN 80	EUTHAN 80	EUTHAN 80	EUTHAN 80
Wheel diameter	inch	12	12	12	12	12
Drive (oil filling)	gal	0,132	0,132	0,132	0,132	0,132

## Technical Data

	Unit	TB 650	TB 750	TB 900	WZB 700	WZB 850
<b>Tank volume</b>						
Clean water tank	gal	30,6	30,6	30,6	30,6	30,6
Waste water tank	gal	30,6	30,6	30,6	30,6	30,6
<b>Brush head</b>						
No. of brushes	Pieces	2	2	2	2	2
Brush speed	rpm	210	200	215	850	850
<b>Suction</b>						
Air flow rate	m <sup>3</sup> /h	110	110	118	110	118
Vacuum	mbar	170	170	170	170	170
<b>Electrical installation</b>						
Nominal voltage	V	24	24	24	24	24
Nominal power (max.) (P1)	W	3260	3260	3260	3100	3100
Power consumption, drive motor (P1 / S2-120 min)	W	816	816	816	816	816
Power consumption, aspirating engine (P1)	W	528	528	528	528	528
Power consumption, brush motor (P1)	W	960	960	960	876	876
Power consumption, water pump (P1)	W	100	100	100	100	100
Protection class		III	III	III	III	III
Type of protection		IPX3	IPX3	IPX3	IPX3	IPX3

## Technical Data

<p><b>Noise emission value</b></p> <p>The sound power level (LwAd) measured according to EN 60335-2-72 under normal under working conditions is:</p> <p>The sound pressure level (LpA) measured according to DIN EN 60335-2-72 (at the driver's ear) under normal working conditions is:</p> <p>Measurement inaccuracy (KpA):</p>	<p>dB (A)</p> <p>dB (A)</p> <p>dB (A)</p>	<p>85</p> <p>66</p> <p>2</p>
<p><b>Vibration</b></p> <p>The weighted effective value of acceleration, measured in accordance with DIN EN ISO 5349, to which the upper parts of the body (hand-arm) are exposed under normal working conditions:</p>	<p>m/s<sup>2</sup></p>	<p>&lt; 2.5</p>

### 5 Maintenance and Service

#### General information



It is essential to pay attention to the information in Chapter "Safety Information" before completing any service or maintenance work!

By adhering to the maintenance work recommended by us, you can be sure that the vehicle is always ready to be put into operation. Maintenance and repair work necessary on a daily and weekly basis can be carried out by a driver trained to complete the work, all other Minuteman system maintenance may only be completed by personnel who are correspondingly qualified and trained. Please contact your nearest Minuteman service center or authorized Minuteman dealer. Failure to observe this annuls any rights to claims under the terms of guarantee in respect of resulting damage or consequential damage.

Always specify the serial number in the case of inquiries and spare parts orders, refer to Section 1.7 - Rating plate.

#### 5.1 Minuteman system maintenance

The Minuteman system maintenance:

- ensures that the Minuteman vehicle is always ready for operation (preventive maintenance),
- minimizes operating costs, maintenance and repair costs,
- ensures the vehicle has a long service life.

Minuteman system maintenance provides individual modules explaining the special technical work to be carried out and prescribes the intervals at which the work should be performed. Parts to be replaced for the individual maintenance tasks are defined and provided in spare parts kits.

#### Minuteman system maintenance K:

Work to be carried out by the customer according to the service and maintenance instructions in the operating manual (daily and weekly). The driver/operator receives proper instruction when the vehicle is delivered.

#### Minuteman system maintenance I:

(every 250 operating hours)

Completed by technical experts from an authorized Minuteman service center in accordance with the specific vehicle system maintenance using spare parts kits.

#### Minuteman system maintenance II:

(every 500 operating hours)

Completed by technical experts from an authorized Minuteman service center in accordance with the specific vehicle system maintenance using spare parts kits.

#### Minuteman system maintenance III/S:

(every 1000 operating hours, safety check)

Completed by technical experts from an authorized Minuteman service center in accordance with the specific vehicle system maintenance using spare parts kits. Completion of all legally prescribed, safety-related tests in accordance with UVV, BGV, TÜV and VDE requirements.



# Maintenance and Service

## 5.2 Proof of Maintenance

<p><b>Handover</b> Upgrading Test drive Handover to customer Instruction completed on:  at _____ operating hours</p>	<p><b>Minuteman System Maintenance I</b> 250 operating hours Workshop Stamp  completed on: at _____ operating hours</p>	<p><b>Minuteman System Maintenance II</b> 500 operating hours Workshop Stamp  completed on: at _____ operating hours</p>	<p><b>Minuteman System Maintenance I</b> 750 operating hours Workshop Stamp  completed on: at _____ operating hours</p>
<p><b>Minuteman System Maintenance S</b> 1000 operating hours Workshop Stamp  completed on: at _____ operating hours</p>	<p><b>Minuteman System Maintenance I</b> 1250 operating hours Workshop Stamp  completed on: at _____ operating hours</p>	<p><b>Minuteman System Maintenance II</b> 1500 operating hours Workshop Stamp  completed on: at _____ operating hours</p>	<p><b>Minuteman System Maintenance I</b> 1750 operating hours Workshop Stamp  completed on: at _____ operating hours</p>
<p><b>Minuteman System Maintenance S</b> 2000 operating hours Workshop Stamp  completed on: at _____ operating hours</p>	<p><b>Minuteman System Maintenance I</b> 2250 operating hours Workshop Stamp  completed on: at _____ operating hours</p>	<p><b>Minuteman System Maintenance II</b> 2500 operating hours Workshop Stamp  completed on: at _____ operating hours</p>	<p><b>Minuteman System Maintenance I</b> 2750 operating hours Workshop Stamp  completed on: at _____ operating hours</p>

## Maintenance and Service

### 5.3 Maintenance Plan Minuteman system maintenance, customer

The following maintenance work must be completed by the customer at the intervals stipulated.

Activity	Interval	
	Daily	Weekly
Empty and clean the waste water tank	o	
Check the lid seal of the waste water tank; clean, if necessary	o	
Check the battery charge; recharge, if necessary	o	
Check the clean water filter; clean or change as necessary	o	
Fill the clean water tank and dose the chemicals	o	
Check the sealing strips on the squeegee; turn or change as necessary	o	
Check the deflector rubber of the side deflector, change as necessary	o	
Check the scrubbing quality of the brush head; clean the brushes, pad and pad holder if necessary		o
Check the suction power of the squeegee; clean or change the sealing strips as necessary		o
Check the suction hose between the squeegee and waste water tank is fitted firmly and for signs of damage		o
Check the brushes and water retaining ring are fitted firmly and for signs of wear, change as necessary		o
Test drive and function test		o

## Maintenance and Service

### Minuteman system maintenance I

The following maintenance work must be completed by an authorized Minuteman service center.

Activity	Interval
	Every 250 operating hours
Check the battery acid level and acid density; top up distilled water (PzS version), if necessary	o
Check the charger (ventilation grid and air channel)	o
Grease the steering pinion and gear rim	o
Check the functionality of the brake	o
Check the brush head; change worn parts as necessary	o
Check the clean water system; change worn parts as necessary	o
Check the waste water and vacuum system; change worn parts as necessary	o
Clean the brush motor ventilation grid of fluff and dirt	o
Check the squeegee connection and rollers, adjust as necessary	o
Check the front safety bar with deflection roller	o
Check the wheel mounting bolts; retighten, if necessary (42 Nm)	o
Check the electrical system; change worn parts as necessary	o
Check the visual appearance of the vehicle (color, corrosion and labels)	o
Test drive and function test	o

## Maintenance and Service

### Minuteman system maintenance II

The following maintenance work must be completed by an authorized Minuteman service center.

Activity	Interval
	Every 500 operating hours
All maintenance work in accordance with Minuteman system maintenance I	o
Read out the error memory and evaluate the error messages	o
Check the electric power (hydraulic motor, brush motor and suction turbine)	o
Change the backup battery and set the real-time clock	o
Check the visual appearance of the vehicle (color, corrosion and labels)	o
Test drive and function test	o

## Maintenance and Service

### Minuteman system maintenance

#### III/S (safety check)

The following maintenance work must be completed by an authorized Minuteman service center at least once a year.

Activity	Interval
	Every 1000 operating hours
All maintenance work in accordance with Minuteman system maintenance II	o
Clean carbon dust from the brush motors and check the carbon brushes move easily and for signs of wear; change the carbon brushes, if necessary	o
Test drive and function test	o

## Maintenance and Service

### 5.4 Battery system

- 1 Seat console
- 2 Battery plug
- 3 Water filling system
- 4 Charger
- 5 Charge status indicator



Handling and changing the batteries, refer to Section 2.2.

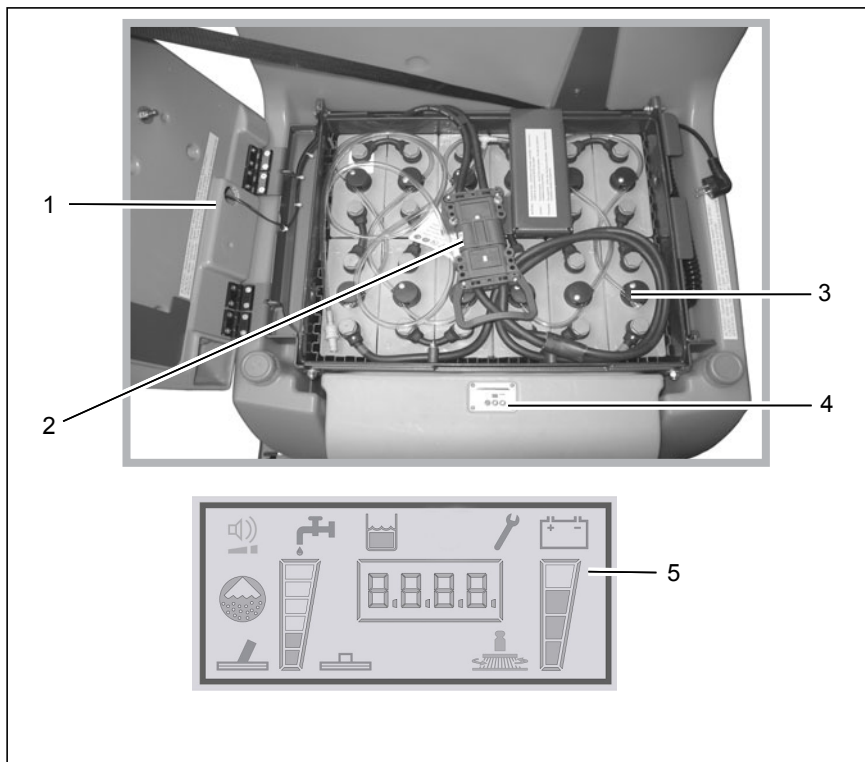

Fig.23

### 5.4.1 Water filling system

For upgrading the trough battery with a water filling system (Fig. 23/3), each individual cell is provided with a closure plug with float indicator. Please read the operating manual from the battery manufacturer for information on the fill level indicator. If some cells are below the set value, distilled water must be refilled in them. In this case, the end piece of the water filling system is connected to a tank containing demineralized water (in accordance with DIN 43530/4). Ensure a sufficient gradient so that the water can flow into the cells. When the fill level required is reached, the plugs close the cells automatically and indicate they are full, the battery can be disconnected from the water tank.



Refilling may only be completed when battery charging has ended (green LED indicator on the charger)

### 5.4.2 Charge status indicator (TSG)

The vehicle is equipped with a charge status indicator (Fig. 23/4) to prevent the batteries being fully discharged. The total discharge signal transducer is integrated in the electronics. If other batteries are used, the total discharge signal transducer must be adjusted.



The total discharge signal transducer may only be adjusted by an authorized Minuteman service center.

### 5.4.3 Servicing the driving batteries

For information on servicing driving batteries, refer to operating manual 88-60-2556.

### 5.4.4 Disposing of batteries

Used batteries with the recycling symbol contain reusable commodities. In accordance with symbol with the crossed out bin, these batteries must not be disposed of in domestic waste. Return and recycling must be agreed on with an authorized Minuteman dealer in accordance with § 6 and 8 BattG (Battery Law)!

## Maintenance and Service

### 5.5 Waste water and clean water tank

- 1 Tank lid
- 2 Maintenance opening, clean water tank
- 3 Filling neck, clean water tank
- 4 Draining hose, clean water tank
- 5 Draining hose, waste water tank
- 6 Filter sieve
- 7 Float switch, waste water tank
- 8 Cleaning opening, sieve
- 9 Fill level indicator, clean water tank
- 10 Clean water sieve with holding band for the filling neck (option)
- 11 Clean water filter
- 12 Clean water tank
- 13 Waste water tank

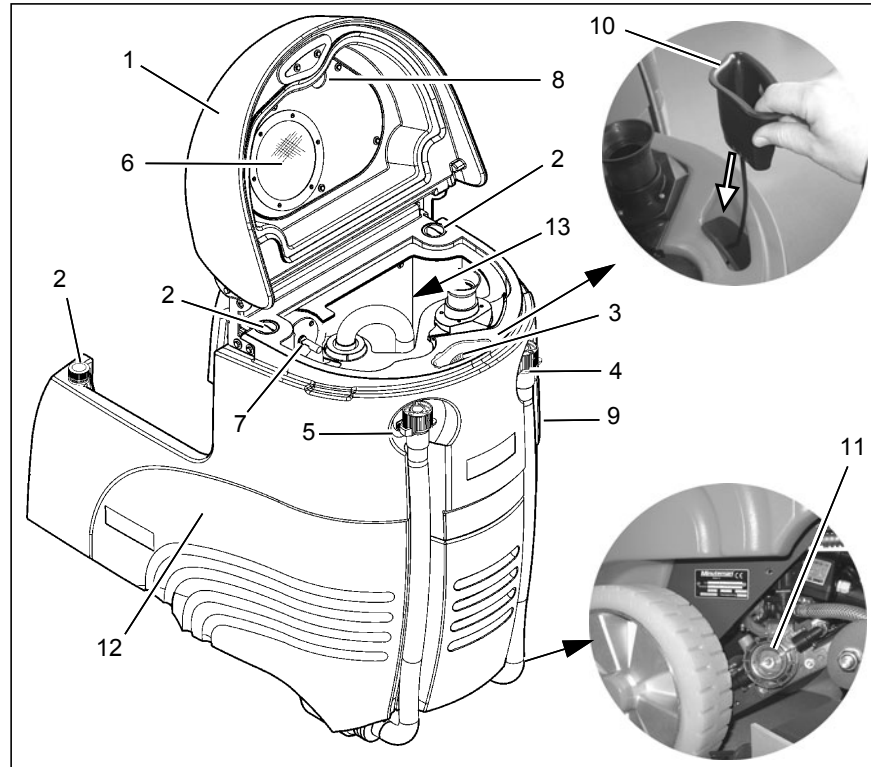

Fig.24



## Maintenance and Service

### 5.5.1 Cleaning the clean water tank

Park the vehicle so that the draining hose (Fig. 24/4) is above a drain in the floor. Remove the draining hose from the holder and open the cap by turning it counterclockwise.

Use the maintenance opening (Fig. 24/2) to clean the clean water tank (Fig. 24/12).

Clean the filter sieve (Fig. 24/6) by inserting a hose in the opening (Fig. 24/8) and flushing the sieve back from the inside.

### 5.5.2 Cleaning the clean water filter

Check the clean water filter (Fig. 24/11) weekly and clean or replace it as necessary.

1. Empty the clean water tank, refer to Section 5.5.1.
2. Screw the filter cap off.
3. Remove the filter element in the filter housing to clean it. Replace it with a new one, if necessary.
4. Replace the filter element and filter cap.

### 5.5.3 Cleaning the waste water tank

Clean the waste water tank (Fig. 24/13) every day or as necessary.

1. Open the tank cap (Fig. 24/1) on the waste water tank.
2. Remove the draining hose (Fig. 24/5) from the holder and empty the waste water tank completely.
3. Flush out the remaining dirt with clean water.
4. Also flush the draining hose.



The waste water tank must always be emptied and flushed clean after finishing work. The float switch (Fig. 24/7) must also be rinsed clean. The cap on the draining hose should be cleaned regularly. Lubricate the O-ring lightly, if necessary.

When disposing of the waste water and the cleaning solution, observe all applicable legal regulations.

When working in the area of the opened waste water tank lid, it must be folded open fully to prevent it being knocked shut unintentionally.

### 5.6 Disk brush head

- 1 Brush head
- 2 Brushes
- 3 Brush ejectors

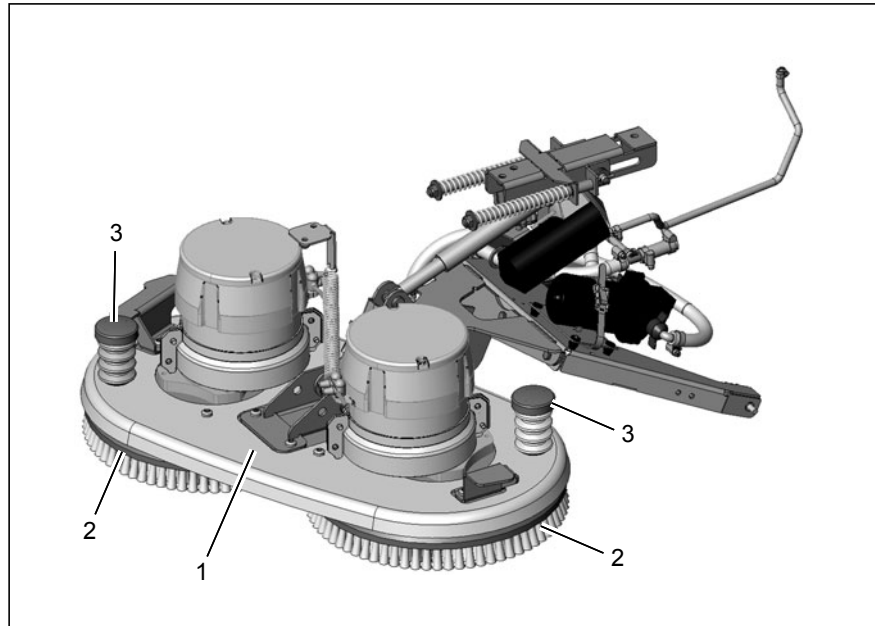

Fig.25

## Maintenance and Service

### **5.6.1 Cleaning the brushes**

Clean the brushes (Fig. 25/2) on the brush head (Fig. 25/1) daily or as necessary.

1. Raise the brush head.
2. Press the brush ejectors (Fig. 25/3) downward and remove the brushes to clean them.

### **5.6.2 Changing the brushes**

Check the brushes on the brush head weekly for signs of wear. In the case of wear to a brush length of 1.5 cm, the brushes must be changed.

1. Raise the brush head.
2. Press the brush ejectors (Fig. 25/3) downward and remove the brushes.
3. Slide the new brush under the brush head and press into the support using both hands.

## 5.7 Cylindrical brush head

- 1 Cylindrical brush head
- 2 Locking lever
- 3 Brushes
- 4 Dirt hopper
- 5 Brush holder

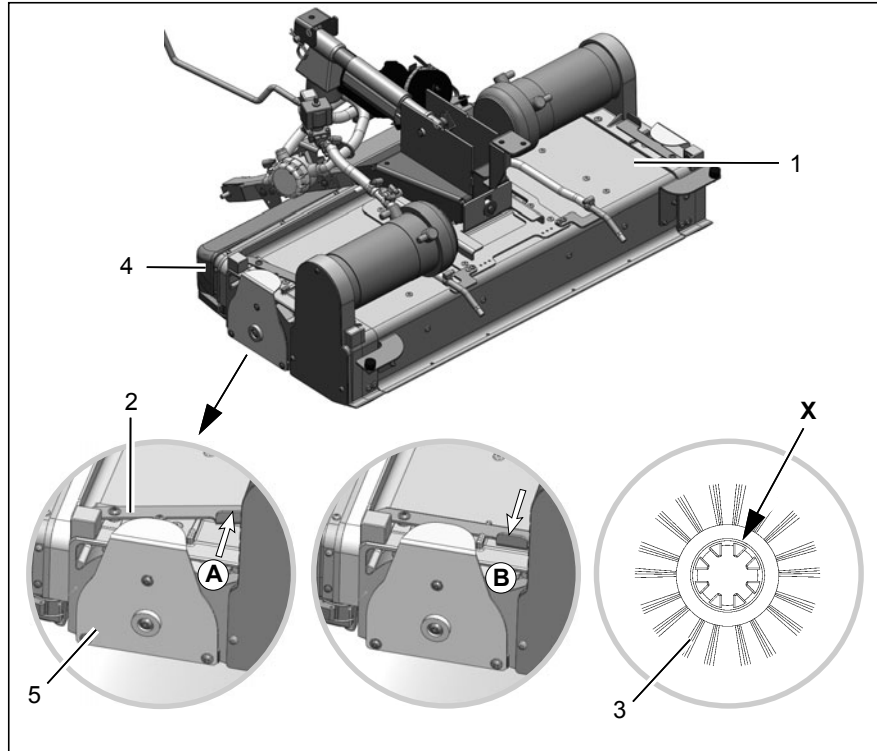

Fig.26

## Maintenance and Service

### 5.7.1 Emptying the dirt hopper

Remove and empty the dirt hopper (Fig. 26/5) daily or as necessary.

### 5.7.2 Disassembling the brushes

Check the brushes (Fig. 26/3) on the cylindrical brush head (Fig. 26/1) weekly for signs of wear and change as necessary.

1. Switch the vehicle off, remove the key.
2. Pivot the deflector away, refer to Section 5.8.
3. Unlock the brush holder (Fig. 26/5): Press the locking lever (Fig. 26/2) to position **A** and remove the brush holder.
4. Pull out the brush (Fig. 26/3) and check it.

### 5.7.3 Installing the brushes

1. Slide the brush in the cylindrical brush head (toothing **X** must point outwards) and allow to snap into place on the oppositely facing catches.
2. Press the locking lever (Fig. 26/2) to position **A** and mount the brush holder.
3. Locking the brush holder (Fig. 26/1): Press the locking lever (Fig. 26/2) to position **B**.
4. Pivot the deflector back, refer to Section 5.8.

### 5.8 Deflector

- 1 Deflector
- 2 Wing nut
- 3 Clamping rail
- 4 Rubber deflector strips
- 5 Locking hooks

#### 5.8.1 Pivoting the deflector away

- 1. Open the locking hooks (Fig. 27/1).
- 2. Pivot the deflector away to the side.

#### 5.8.2 Changing the deflector rubber

Check the deflector rubber (Fig. 27/4) daily or as required and change it when necessary.

- 1. Loosen the wing nut (Fig. 27/2).
- 2. Slide the clamping rail (Fig. 27/3) to the front until the hooks on the inner side are free and the clamping rail can be moved away.
- 3. Change the deflector rubber (Fig. 27/4).
- 4. Reassemble in the reverse sequence.

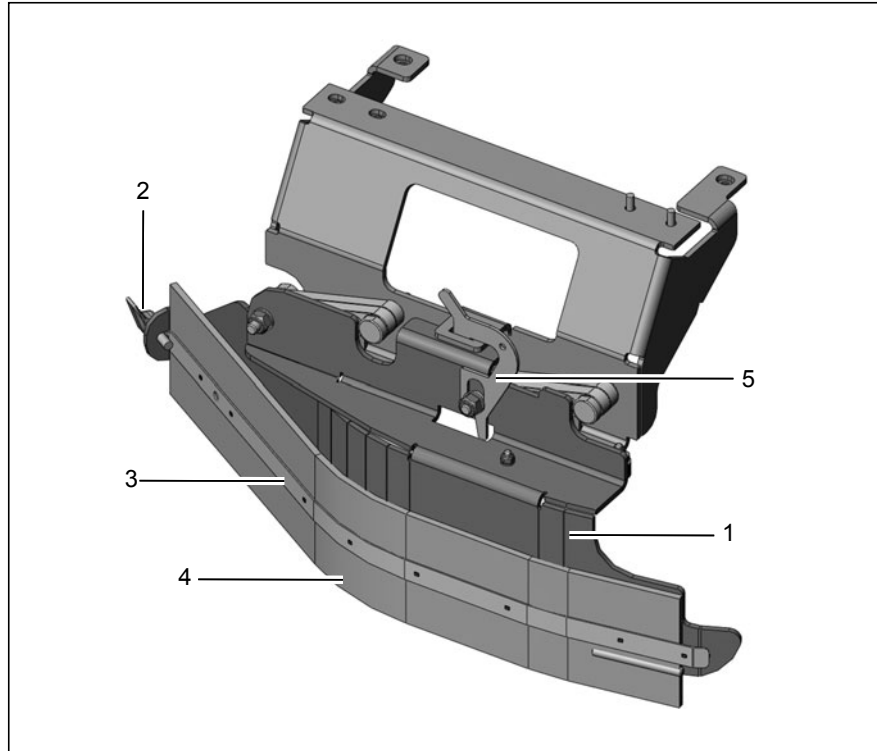

Fig.27

### 5.9 Squeegee

- 1 Squeegee
- 2 Star-shaped knob
- 3 Screw for angle adjustment
- 4 Suction hose
- 5 Fastening device
- 6 Washers for height adjustment

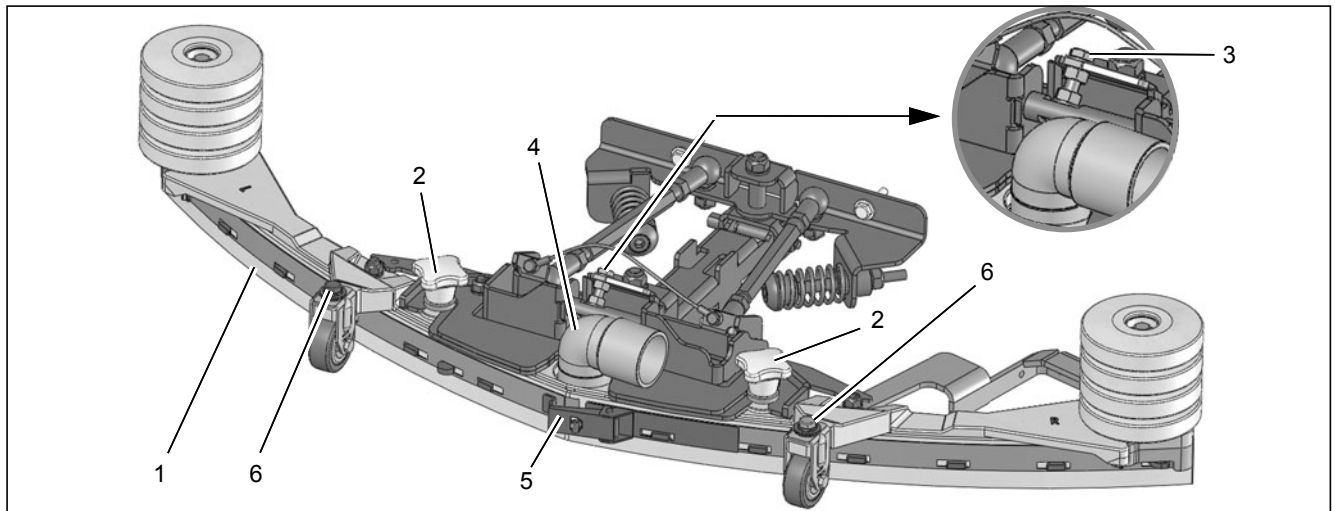

Fig.28

### **5.9.1 Cleaning the squeegee**

Check the squeegee (Fig. 28/1) daily and clean as necessary.

To clean the squeegee, raise it, disconnect the suction hose (Fig. 28/4), loosen the two star-shaped knobs (Fig. 28/2) and remove the squeegee.

### **5.9.2 Changing the sealing strips**

Check the inner and outer sealing strips on the squeegee (Fig. 28/1) weekly for signs of wear. The sealing strips can be turned four times (90°) and reused.

1. Raise the squeegee.
2. Pull off the suction hose, loosen the two star-shaped knobs and remove the squeegee.
3. Loosen the fastening device (Fig. 28/5) and remove the outer sealing strip. Turn the sealing strip or replace it, as necessary. Change the inner sealing strip in the same way.



### 5.9.3 Adjusting the sealing strips Angle adjustment

The angle adjustment is the decisive factor in ensuring the squeegee's sealing strips lie evenly on the floor.

1. Park the machine on a level surface and lower the squeegee.
2. Loosen the counternut on the screw (Fig. 28/3) and use the counternut to adjust the squeegee so that the ends of the sealing strips just make contact with the floor.

Fig. A

Turn the counternut counterclockwise: Distance from sealing strip to floor is reduced in the middle.

Fig. B

Turn the counternut clockwise: Distance from sealing strip to floor is increased in the middle.

3. Switch the vehicle on and check the suction pattern. While driving, the sealing strips must make an overall, even contact with the floor (in the center and at both ends).
4. Tighten the counternut of the adjusting bolt at 7 Nm.

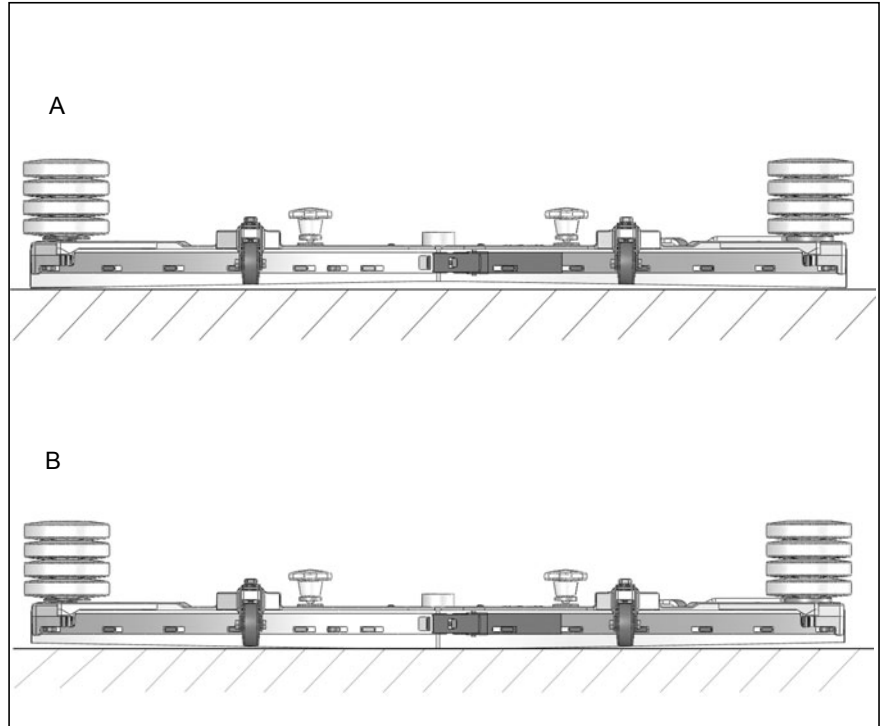

Fig.29

## Maintenance and Service

### Height adjustment

The height adjustment is set to 3 mm at the factory. If, despite an optimum angle adjustment, streaks are produced, the distance between the rollers and floor must be adjusted by altering the number of washers (Fig. 28/6) on the holder.

In the case of very smooth floors, e.g. laminated screed, PVC, linoleum, etc.:  
Number of washers = 2. This corresponds to a clearance of approx. 2 mm to the floor.

In the case of very uneven floors, e.g. poorly laid tiles (puddles form):  
Number of washers = 4. This corresponds to a clearance of approx. 4 mm.

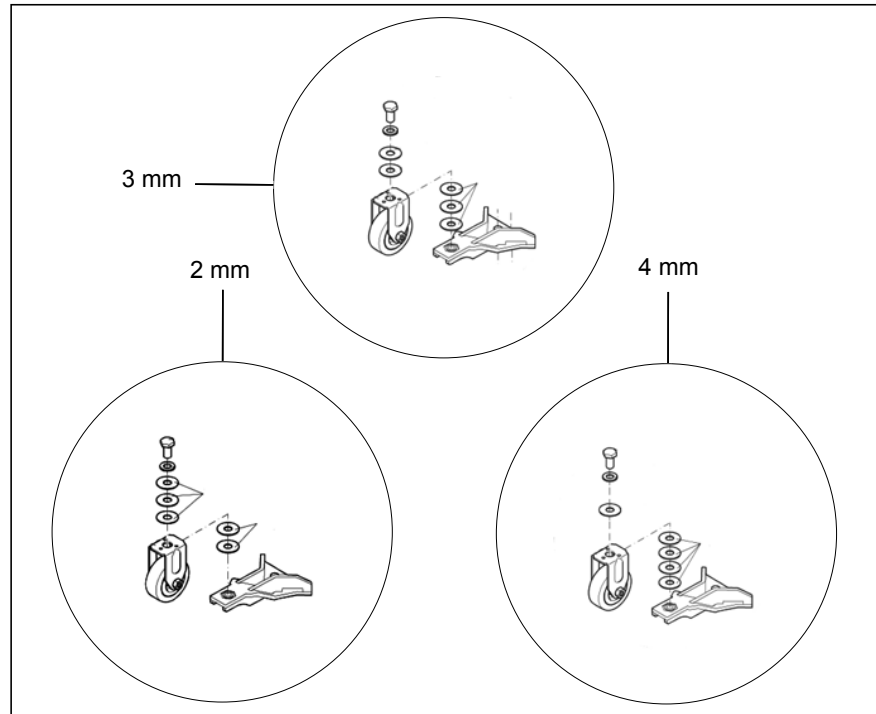

## Maintenance and Service

## Minuteman International Made Simple Commercial Limited Warranty

Minuteman International, Inc. warrants to the original purchaser/user that the product is free from defects in workmanship and materials under normal use. Minuteman will, at its option, repair or replace without charge, parts that fail under normal use and service when operated and maintained in accordance with the applicable operation and instruction manuals. All warranty claims must be submitted through and approved by factory authorized repair stations.

This warranty does not apply to normal wear, or to items whose life is dependent on their use and care, such as belts, cords, switches, hoses, rubber parts, electrical motor components or adjustments. Parts not manufactured by Minuteman are covered by and subject to the warranties and/or guarantees of their manufacturers. Please contact Minuteman for procedures in warranty claims against these manufacturers.

**Special warning to purchaser** -- Use of replacement filters and/or prefilters not manufactured by Minuteman or its designated licensees, will void all warranties expressed or implied. A potential health hazard exists without original equipment replacement.

All warranted items become the sole property of Minuteman or its original manufacturer, whichever the case may be.

Minuteman disclaims any implied warranty, including the warranty of merchantability and the warranty of fitness for a particular purpose. Minuteman assumes no responsibility for any special, incidental or consequential damages.

This limited warranty is applicable only in the U.S.A. and Canada, and is extended only to the original user/purchaser of this product. Customers outside the U.S.A. and Canada should contact their local distributor for export warranty policies. Minuteman is not responsible for costs or repairs performed by persons other than those specifically authorized by Minuteman. This warranty does not apply to damage from transportation, alterations by unauthorized persons, misuse or abuse of the equipment, use of non-compatible chemicals, or damage to property, or loss of income due to malfunctions of the product.

## Minuteman International Made Simple Commercial Limited Warranty

If a difficulty develops with this machine, you should contact the dealer from whom it was purchased.

This warranty gives you specific legal rights, and you may have other rights which vary from state to state. Some states do not allow the exclusion or limitation of special, incidental or consequential damages, or limitations on how long an implied warranty lasts, so the above exclusions and limitations may not apply to you.

### **Cord Electric Group Exceptions**

Three years parts, two years labor, ninety days travel (Not to exceed two hours)  
Port-A-Scrub, one year parts, six months labor  
MPV 13, one year parts  
MPV 14 and 18, two years parts, one year labor  
RapidAir blower, one year parts, one year labor  
Explosion-Proof Vacuum, one year parts, one year labor  
Pneumatic Vacuums, three years parts, one year labor  
EX 12 and EX12H, one year parts, one year labor

### **Battery Operated Group**

#### **Exceptions**

Three years parts, two years labor, ninety days travel  
(Not to exceed two hours)  
Sweepers, one year parts, one year labor, ninety days travel  
(Not to exceed two hours)

### **Internal Combustion Group**

One year parts, one year labor, ninety day travel  
(Not to exceed two hours)

### **Replacement Parts**

Ninety days

### **Batteries**

0-3 months replacement, 4-12 months pro-rate

### **Polypropylene Plastic Tanks**

Ten years, no additional labor

# Excellence Meets Clean



Minuteman International • 14N845 U.S. Route 20 • Pingree Grove, IL 60140 U.S.A  
Telephone: (847) 264-5400 • FAX: (847) 683-5207