

SERVICE MANUAL
MOYNO® 500 PUMPS
300 SERIES
331, 332, 333, 344, 356 AND 367 MODELS



Mechanical Seal Models



Packing Gland Models

DESIGN FEATURES	MODELS				
	33101 34401 33201 35601 33301 36701	33104 34404 33204 35604 33304 36704	33108 33308 33208 34408	34411 35611	35613
Housing:	Cast Iron	AISI 316 SS	Nylon	Cast Iron	AISI 316 SS
Pump Rotor:	Chrome plated 416 SS	Chrome plated 316 SS	Chrome plated 416 SS	Chrome plated 416 SS	Chrome plated 316 SS
Pump Stator:	NBR (Nitrile)	NBR (Nitrile)	NBR (Nitrile)	NBR (Nitrile)	NBR (Nitrile)
Shaft:	416 SS	316 SS	416 SS	416 SS	316 SS
Flexible Joint:	Carbon steel/ NBR	316 SS/ NBR	Carbon steel/ NBR	Carbon steel/ NBR	316 SS/ NBR
Bearings:	Ball (sealed)	Ball (sealed)	Ball (sealed)	Ball (sealed)	Ball (sealed)
Mechanical Seal:	Carbon-ceramic	Carbon-ceramic	Carbon-ceramic	---	---
Packing:	---	---	---	Braided PTFE	Braided PTFE

Note: Alternate elastomers available. Refer to Repair/Conversion kit numbers, page 8.

INSTALLATION

Mounting Position. Pump may be mounted in any position. When mounting vertically, it is necessary to keep bearings above seals to prevent possible seal leakage into bearings.

Pre-Wetting. Prior to connecting pump, wet pump elements and mechanical seal or packing by adding fluid to be pumped into suction and discharge ports. Turn shaft over several times in a clockwise direction to work fluid into elements.

Piping. Piping to pump should be self-supporting to avoid excessive strain on pump housings. See Table 1 for suction and discharge port sizes of each pump model. Use pipe "dope" or tape to facilitate disassembly and to provide seal.

Drive. On belt driven units, adjust belt tension to point of non-slip. Do not overtighten.

On direct drive units, coupling components should be aligned and spaced at least 1/16" apart.

Pump rotation must be clockwise when facing shaft to prevent damage to pump. Check direction of rotation before startup.

Water Flush of Packing (356 Models Only). The packing may be either grease lubricated through a grease fitting in the stuffing box or have plumbing connected to the housing to allow a water flush.

Maximum speed is 1750 rpm.

When the material being pumped is abrasive in nature, it may be advantageous to flush the packing to prevent leakage under packing and excessive shaft wear.

Clean water can be injected through a 1/8" NPT tapped hole that normally houses the grease fitting for lubricating the packing. The water can be permitted to leak axially along the shaft in either direction or can be removed from the second tapped hole in the stuffing box. In both cases, the discharge from the stuffing box should be throttled slightly to maintain 10-15 PSI higher pressure in the stuffing box than is present in the discharge housing.

Table 1. Pump Data

Pump Models	331	332	333	344	356	367
Suction Port (NPT)	3/4*	3/4*	3/4*	3/4*	1-1/2	2
Discharge Port (NPT)	3/4	3/4	3/4	3/4	1-1/4	2
Discharge Pressure (psig)	150	100	50	40	50	50

*08 versions = 1" NPT

Table 2. Temperature Limits

Elastomer	Temperature Limits
*NBR	10°-160°F
*EPDM	10°-210°F
*FPM	10°-240°F

*NBR = Nitrile

*EPDM = Ethylene-Propylene-Diene Terpolymer

*FPM = Fluoroelastomer

OPERATION

Self-Priming. With wetted pumping elements, the pump is capable of 25 feet of suction lift when operating at 1750 rpm with pipe size equal to port size.

DO NOT RUN DRY. Unit depends on liquid pumped for lubrication. For proper lubrication, flow rate should be at least 10% of rated capacity.

Pressure and Temperature Limits. See Table 1 for maximum discharge pressure of each model. Unit is suitable for service at temperatures shown in Table 2.

Storage. Always drain pump for extended storage periods by removing suction housing bolts and loosening suction housing.

TROUBLE SHOOTING

WARNING: Before making adjustments, disconnect power source and thoroughly bleed pressure from system. Failure to do so could result in electric shock or serious bodily harm.

Failure To Pump.

1. Belt or coupling slip: Adjust belt tension or tighten set screw on coupling.
2. Stator torn; possibly excessive pressure: Replace stator, check pressure at discharge port.
3. Wrong rotation: Rotation must be clockwise when facing shaft.

4. Threads in rotor or on shaft stripped: Replace part. Check for proper rotation.
5. Excessive suction lift or vacuum.

Pump Overloads.

1. Excessive discharge pressure: Check discharge pressure for maximum rating given in Table 1. Check for obstruction in discharge pipe.
2. Fluid viscosity too high: Limit fluid viscosity to 20,000 CP or 100,000 SSU.

Viscosity CP	Limit RPM
1-300	1750
300-1,000	1200
1,000-2,000	700
2,000-5,000	350
5,000-10,000	180
10,000-20,000	100

3. Insufficient motor HP: Check HP requirement.

Noisy Operation.

1. Starved suction: Check fluid supply, length of suction line, and obstructions in pipe.
2. Bearings worn: Replace parts; check alignment, belt tension, pressure at discharge port.
3. Broken flexible joint: Replace part, check pressure at discharge port.
4. Insufficient mounting: Mount to be secure to firm base. Vibration induced noise can be reduced by using mount pads and short sections of hose on suction and discharge ports.

Mechanical Seal Leakage (Mechanical Seal Models Only).

1. Leakage at startup: If leakage is slight, allow pump to run several hours to let faces run in.
2. Persistent seal leakage: Faces may be cracked from freezing or thermal shock. Replace seal.

Packing Leakage (Packing Models Only).

1. Leakage at startup: Adjust packing as outlined in maintenance instructions.
- Note: Slight leakage is necessary for lubrication of packing.
2. Persistent leakage: Packing rings and/or shaft may be worn. Replace parts as required.

Pump Will Not Prime.

1. Air leak on suction side: Check pipe connections.

MAINTENANCE

General. These pumps have been designed for a minimum of maintenance, the extent of which is routine lubrication and adjustment of packing. The pump is one of the easiest to work on in that the main elements are very accessible and require few tools to disassemble.

Packing Lubrication (356 Models Only). The zerk fitting on the side of the suction housing leads to the lantern ring halves in the mid-section of the packings. At least once a week, inject a small quantity of good quality grease, such as MPG-2 Multi Purpose Grease (Du Bois Chemical), or equivalent, into the zerk fitting to lubricate the packings.

Note: For Model 34411, lubricate packing by applying a liberal amount of grease during assembly.

Packing Adjustment (Packing Models Only).

Packing gland attaching nuts should be evenly adjusted so they are little more than finger tight. Over-tightening of the packing gland may result in premature packing failure and possible damage to the shaft and gland.

When the packing is new, frequent minor adjustments are recommended for the first few hours of operation in order to compress and seat the packing. Be sure to allow slight leakage for lubrication of packing.

When excessive leakage can no longer be regulated by tightening the gland nuts, remove and replace the packings in accordance with the DISASSEMBLY and REASSEMBLY instructions. The entire pump need not be disassembled to replace the packings.

Bearing Lubrication. The prelubricated, fully sealed bearings do not require additional lubrication.

PUMP DISASSEMBLY

WARNING: Before disassembling pump, disconnect power source and thoroughly bleed pressure from system. Failure to do so could result in electric shock or serious bodily harm.

To Disassemble Mechanical Seal Models:

1. Disconnect suction and discharge piping.
2. Remove screws (112) holding suction housing (2) to pump body (1). Remove suction housing and stator (21).
3. Remove rotor (22) from flexible joint (24) by turning counter-clockwise (RH thread). Use 3/16 inch diameter punch to remove rotor pin (45) on Model 36701.
4. Flexible joint (24) can be removed from shaft (26) by using a 3/16 inch allen wrench in end of joint (1/4 inch wrench on 356 Models) and turn counter-clockwise. Use 3/16 inch diameter punch to remove shaft pin (46) on Model 36701.
5. Carefully slide mechanical seal (69) off shaft (26). Carefully pry seal seat out of pump body (1). If any parts of mechanical seal are worn or broken, the complete seal assembly should be replaced. Seal components are matched parts and are not interchangeable.
6. The bearings (29) and shaft (26) assembly can be removed from pump body (1) after snap ring (66) has been removed. To remove the assembly, lightly tap the shaft at threaded end using a block of wood to protect the threads. The bearings may be pressed off the shaft.

To Disassemble Packing Models:

1. Disconnect suction and discharge piping.
2. Remove screws (112) which hold suction housing (2) to pump body (1). Remove suction housing and stator (21).
3. Remove rotor (22) from flexible joint (24) by turning in a counter-clockwise direction (RH thread).
4. Flexible joint (24) can be removed by using a 3/16 inch allen wrench in end of joint (1/4 inch wrench on 356 Models) and turn in a counter-clockwise direction.
5. The packing (42) can be removed without removing the shaft (26) using the following procedure:
 - a. Remove gland bolts (47).
 - b. Slide gland (41) away from packing (42).
 - c. Pull out packing (42) (and lantern ring halves (57) on 356 Models) using a packing removing tool.

Note: Packing can be removed after shaft has been removed by pushing out from pump side of pump body after gland (41) has been detached.

6. The bearings (29) and shaft (26) assembly can be removed from pump body (1) after snap ring (66) has been removed. To remove the assembly, lightly tap the shaft at threaded end using a block of wood to protect the threads.
7. To disassemble shaft assembly, remove snap ring (66A) from shaft (26) and press bearings (29) and bearing spacer (33) off the shaft.

PUMP ASSEMBLY**To Assemble Mechanical Seal Models:**

1. Press bearings (29) on shaft (26), and locate slinger ring (77) near bearing on threaded end of shaft.

Note: When replacing bearings, always press on the inner race when assembling to shaft, and on the outer race when pressing bearings into the housings.

2. Press shaft assembly into pump body (1) securing with snap ring (66).
3. Install mechanical seal (69) using the following procedure:
 - a. Clean and oil sealing faces using a clean light oil (not grease).

Caution: Do not use oil on EPDM parts. Substitute glycerin or soap and water.

- b. Oil the outer surface of the seal seat, and push the assembly into the bore in the pump body (1), seating it firmly and squarely.
 - c. After cleaning and oiling the shaft, slide the seal body along the shaft until it meets the seal seat.
 - d. Install seal spring and spring retainer on shaft.
4. Thread flexible joint (24) into shaft (26) in a clockwise direction (RH thread). On 356 Models, install seal spacer (69A) and washer (116) before threading flexible joint onto shaft in a clockwise direction. On Model 36701, use shaft pin (46) to pin flexible joint (24) to shaft.
 5. Thread rotor (22) onto flexible joint (24) in a clockwise direction (RH thread). On Model 36701, pin rotor (22) to joint using rotor pin (45).
 6. Slide stator (21) on rotor (22). On 331 and 332 Models, insert rounded end of stator ring (135) into end of stator prior to installing stator on rotor.
 7. Secure stator (21) and suction housing (2), with suction port vertically up, to pump body (1) using screws (112).
 8. Proceed as in installation instructions.

To Assemble Packing Models:

1. Press bearings (29), with bearing spacer (33) in between, on shaft (26) and secure in place using snap ring (66A).

Note: When replacing bearings, always press on the inner race when assembling to shaft, and on the outer race when pressing bearings into the housings.

2. Install packing (42) before installing shaft assembly using the following procedure:
 - a. Lubricate each individual ring of packing with a grease that is insoluble in the fluid being pumped.
 - b. Individually assemble each ring of packing loosely in the packing chamber of the pump body (1). Stagger splits on rings. (Four rings, 3/16 inch square required on Model 34411; four rings, 1/4 inch square and two lantern ring halves (57) assembled between two rings on 356 Models).
 - c. Loosely install packing gland (41) on pump body (1) using gland bolts (47).
3. Press shaft assembly into pump body (1) positioning slinger ring (77) between packing gland (41) and bearing end of pump body. Secure the shaft assembly with snap ring (66).
4. Thread flexible joint (24) into shaft (26) in a clockwise direction (RH thread).
5. Thread rotor (22) onto flexible joint (24) in a clockwise direction (RH thread).
6. Slide stator (21) on rotor (22). On 331 and 332 Models, insert rounded end of stator ring (135) into end of stator prior to installing stator on rotor.
7. Secure stator (21) and suction housing (2), with suction port vertically up, to pump body (1) using screws (112).
8. Proceed as in installation instructions.

Note: Adjust newly installed packing as described in maintenance procedure.

WARNING: Replace belt or coupling guards before reconnecting power.



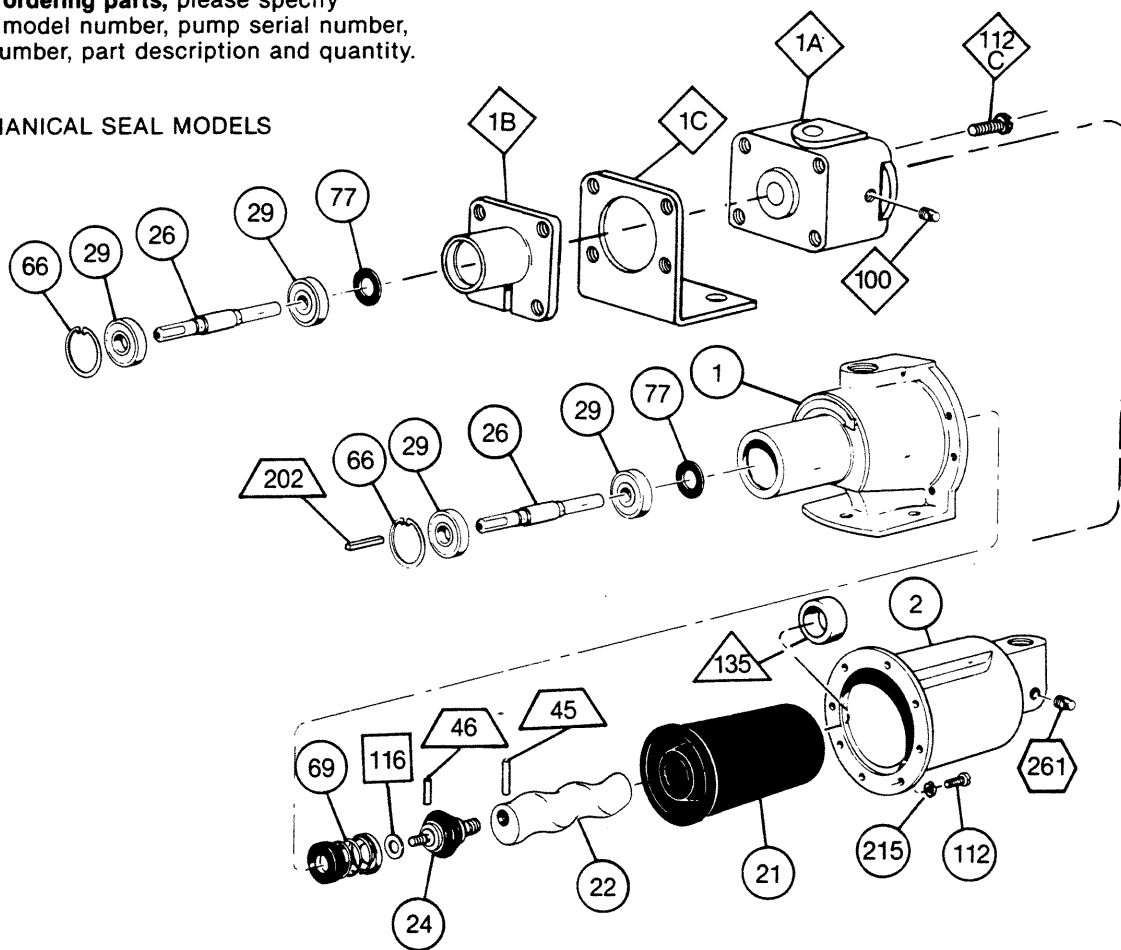

When ordering parts, please specify pump model number, pump serial number, part number, part description and quantity.

MECHANICAL SEAL MODELS

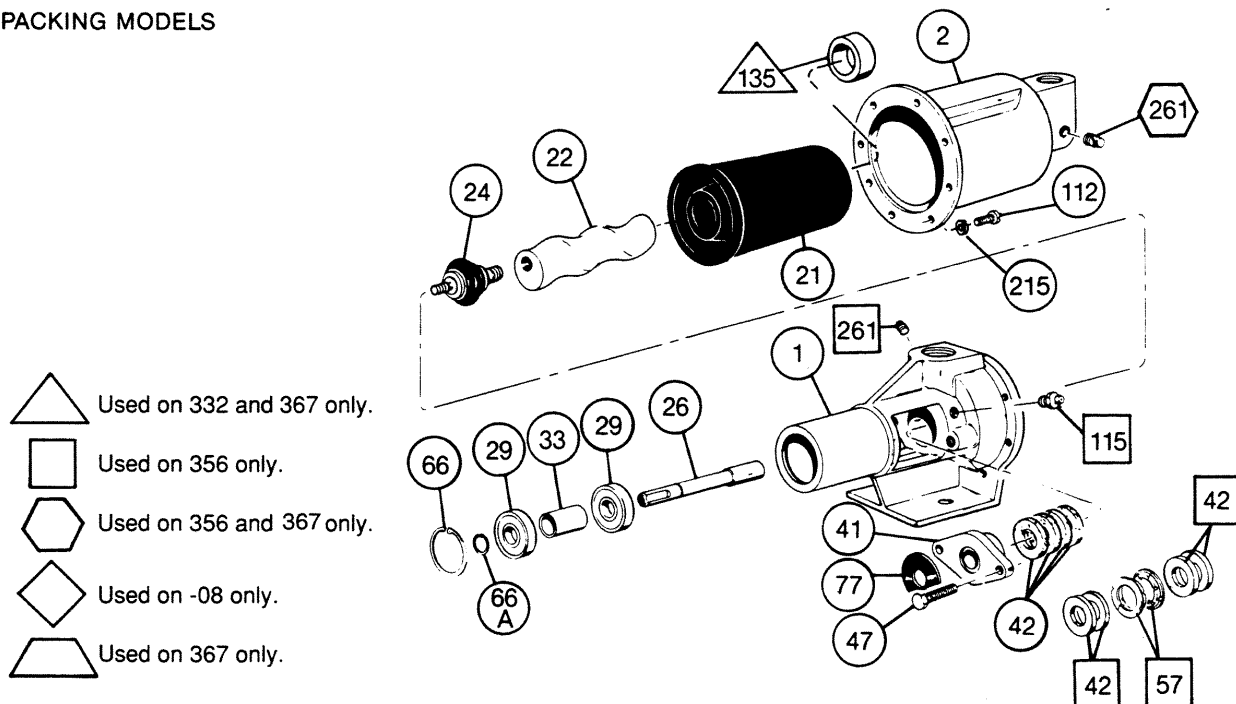

PACKING MODELS



-  Used on 332 and 367 only.
-  Used on 356 only.
-  Used on 356 and 367 only.
-  Used on -08 only.
-  Used on 367 only.

PARTS LIST — 331, 332, 333, AND 344 MODELS

Item No.	Description	Mechanical Seal Models			Packing Gland Models
		33101 33201 33301 34401	33104 33204 33304 34404	33108 33208 33308 34408	
1	Pump Body	330-1065-002	330-1910-002		340-1000-001
1A	Discharge Housing			340-2362-000	
1B	Bearing Housing			330-4587-000	
1C	Pump Base			340-2369-000	
2	Suction Housing	330-1064-002	330-1911-002	330-4536-000	330-1064-002
*21	Stator	See Stator section below.			
*22	Rotor	See Rotor section below with circled numbers for each series.			
		①	②	①	①
24	Joint	Carbon Steel/NBR 320-1511-000	316 SS/NBR 320-3759-000	Carbon Steel/NBR 320-1511-000	
26	Drive Shaft	320-1499-000	320-2938-000	320-1499-000	320-2448-000
29	Bearing (2 req.)	630-0502-031			
33	Bearing Spacer				320-1900-000
41	Packing Gland				320-0101-004
42	Packing				340-3396-005
47	Gland Bolt				619-1520-161
66	Snap Ring	320-1506-000			
66A	Snap Ring				320-4182000
69	Mechanical Seal	320-2424-000			
77	Slinger Ring	320-6382-000			320-6384-000
100	Pipe Plug (3 req.)			610-0120-021	
112	Screws (8 req.)	619-1430-103	320-5968-000	619-0860-081	619-1430-103
112C	Screws (4 req.)			61 9-0890-281	
135	Stator Ring (331 -332 only)	320-7812-000			
215	Lock Washer (8 req.)	320-6464-000			

*Recommended spare parts.

STATORS		Models			
		331	332	333	344
21	Standard Stator, NBR All Models	340-3501-120	340-3502-120	340-3503-120	340-3504-120
21	EPDM Stator	340-3501-320	340-3502-320	340-3503-320	340-3504-320
21	FPM Stator	340-3501-520	340-3502-520	340-3503-520	340-3504-520
ROTORS					
22	① 416SS - All Models	320-2729-000	330-0906-000	320-1394-000	320-1841-000
22	② 316SS - All Models	320-2933-000	320-2942-000	320-2936-000	320-2934-000

See page 8 for Repair/Conversion Kits

PARTS LIST — 356 AND 367 MODELS

Item No.	Description	Mechanical Seal Models		Packing Gland Models		Mechanical Seal Model	
		35601	35604	35611	35613	36701	36704
1	Pump Body	Cast Iron 340-0636-000	316SS 340-1550-000	Cast Iron 350-0420-000	316SS 350-0491-000	Cast Iron 350-0423-000	316SS 350-0423-007
2	Suction Housing	350-0280-000	350-0489-000	350-0280-000	350-0489-000	350-0302-000	350-0302-007
*21	Stator	NBR 340-3505-120		NBR 340-3505-120		NBR 340-3506-120	
22	Rotor	416SS 320-2304-000	316SS 320-4431-000	416SS 320-2304-000	316SS 320-4431-000	416SS 330-2042-000	316SS 330-3077-000
24	Flex Joint	Carbon Steel 320-1583-000	316SS 320-4427-000	Carbon Steel 320-1583-000	316SS 320-4427-000	Carbon Steel 320-1749-000	316SS 320-4436-000
26	Drive Shaft	320-1759-000	320-4430-000	320-2765-000	320-4435-000	330-1805-000	330-1805-015
29	Bearing (2 req.)	630-0552-051				630-0552-061	
33	Bearing Spacer			320-2764-000			
41	Packing Gland			320-0003-004	320-0003-007		
*42	Packing			340-3396-008			
45	Rotor Pin					320-4439-002	
46	Shaft Pin					320-4439-001	
47	Gland Bolt			619-1530-241			
57	Lantern Ring Half**			320-6585-000			
66	Snap Ring	320-1758-000				320-2794-000	
66A	Snap Ring			320-3533-000			
*69	Mechanical Seal	320-3945-000				320-1750-000	
69A	Seal Spacer	320-4434-000					
77	Slinger Ring	320-6383-000		320-6385-000		320-6385-000	
112	Screws (6 req.)	619-1530-161				619-1530-161	
115	Zerk Fitting			320-2503-001			
135	Stator Spacer	330-7594-000					
202	Shaft Key					611-0040-240	
215	Lock Washer (6 req.)	623-0010-411					
261	Pipe Plug	610-0120-011	610-0420-010	610-0120-011	610-0420-010	610-0120-011	610-0420-010

*Recommended spare parts.

**2 Required

See page 8 for Repair/Conversion Kits

REPAIR/CONVERSION KIT NUMBERS

ELASTOMER REPAIR/CONVERSION KITS

Item No.	Description	331 Models			332 Models		
		NBR	EPDM	FPM	NBR	EPDM	FPM
—	Kit No.	311-9026-000	311-9025-000	311-9054-000	311-9027-000	311-9038-000	311-9055-000
21	• Stator	340-3501-120	340-3501-320	340-3501-520	340-3502-120	340-3502-320	340-3502-520
24	• Joint	320-1511-000‡	320-6367-000†	320-4670-000†	320-1511-000‡	320-6367-000†	320-4670-000†
69	• Seal	320-2424-000	320-6379-000	320-6501-000	320-2424-000	320-6379-000	320-6501-000
Item No.	Description	333 Models			344 Models		
		NBR	EPDM	FPM	NBR	EPDM	FPM
—	Kit No.	311-9029-000	311-9028-000	311-9056-000	311-9031-000	311-9030-000	311-9057-000
21	• Stator	340-3503-120	340-3503-320	340-3503-520	340-3504-120	340-3504320	340-3504520
24	• Joint	320-1511-000‡	320-6367-000†	320-4670-000†	320-1511-000‡	320-6367-000†	320-4670-000†
69	• Seal	320-2424-000	320-6379-000	320-6501-000	320-2424-000	320-6379-000	320-6501-000

†316SS/with appropriate elastomer.

‡Carbon steel. NBR kits are available only with carbon steel joints; a 316SS/NBR joint for 331-344 Models is available as 320-3759-000.

Item No.	Description	356 Models			367 Models		
		NBR	EPDM	FPM	NBR	EPDM	FPM
—	Kit No. (Mech. Seal Models)	311-9033-000	311-9032-000	311-9058-000	311-9060-000	311-9036-000	311-9124-000
21	• Stator	340-3505-120	340-3505-320	340-3505-520	340-3506-120	340-3506-320	340-3506-520
24	• Flex Joint	320-1583-000‡	320-6369-000†	320-4671-000†	320-1749-000‡	320-6378-000‡	3206515-000‡
69	• Seal	320-3945-000	320-6380-000	320-6510-000	320-1750-000	320-6390-000	320-6517-000
45	• Rotor Pins				320-4439-002	320-4439-002	320-4439-002
46	• Shaft Pin				320-4439-001	320-4439-001	320-4439-001
—	Kit No (Packing Gland Models)	311-9035-000	311-9034-000	311-9059-000			
21	• Stator	340-3505-120	340-3505-320	340-3505-520			
24	• Joint	320-1583-000‡	320-6369-000†	320-4671-000†			

†316SS/with appropriate elastomer.

‡Carbon steel. NBR kits are available only with carbon steel joints; a 316SS/NBR joint for Model 35604 and 35613 pumps is available as 320-4427-000; a 316SS/NBR joint for model 36704 is available as 320-4436-000.

ABRASION RESISTANT SEALS

Elastomer	Models		
	331-344	356	36701
NBR	3206460000	3206505000	3206511000
EPDM	3206502000	3206506000	3206512000
FPM	3206503000	3206507000	3206513000

NBR = Nitrile

EPDM = Ethylene-Propylene-Diene Terpolymer

FPM = Fluoroelastomer