

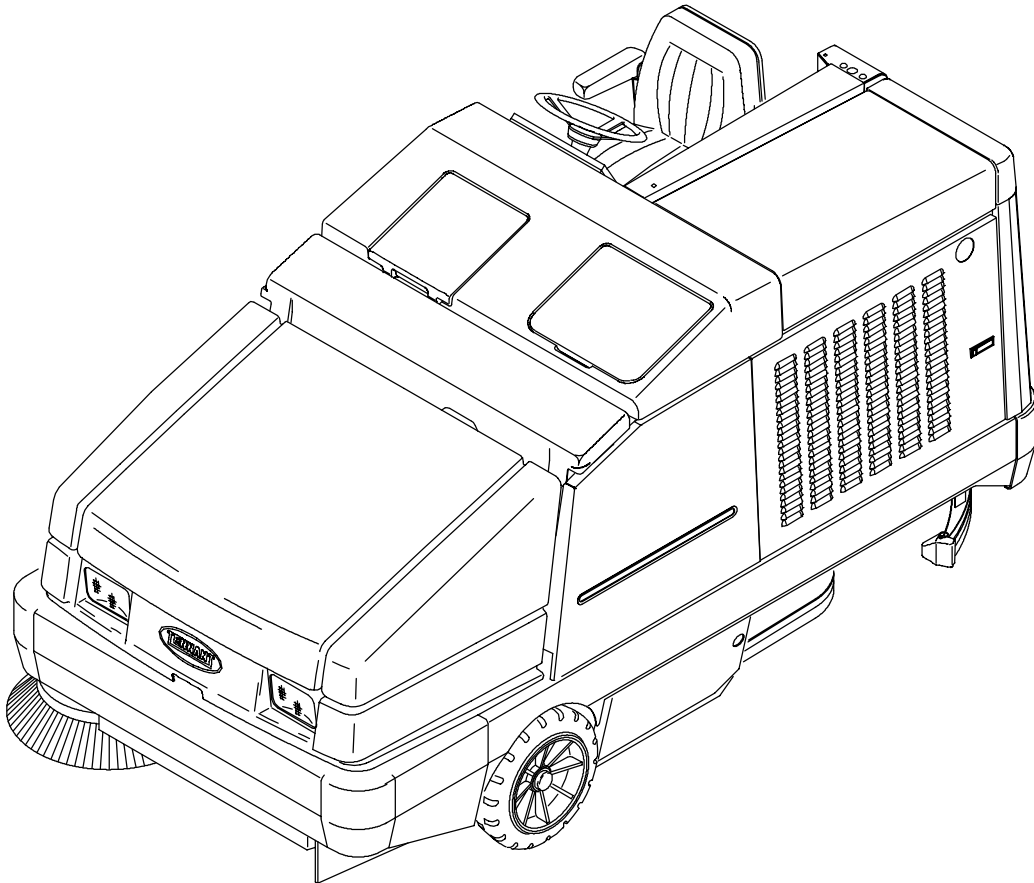

8410

Service Manual



MM392
Rev. 03 (5-02)





This service manual is intended to be an aid for the disassembly and reassembly of your TENNANT Model 8410.

The set is organized into eight major groups: General Information, Chassis, Sweeping, Scrubbing, Electrical, Hydraulics, Engine-G/LPG and Engine-D.

General Information: Machine transport, machine jacking, machine storage, machine specifications, and machine maintenance chart.

Chassis: Tire/wheel replacement, brake adjustment and replacement, chassis lubrication, steering adjustment and replacement, and cover/door adjustment.

Sweeping: Hopper repair/replacement, brush repair/replacement. skirt/seal repair/replacement, and sweeping troubleshooting.

Scrubbing: Scrubber head repair/replacement, brush repair/replacement. squeegee repair/replacement, and scrubber troubleshooting.

Electrical: Battery maintenance and replacement, instrument panel replacement, and electrical troubleshooting.

Hydraulics: Valve replacement/repair, motor replacement/repair, cylinder replacement/repair, pump replacement/repair, filter replacement, and hydraulics troubleshooting.

Engine - G/LPG: Air filter replacement, oil changing, cooling system maintenance/repair, fuel system maintenance/repair, governor adjustment/repair, engine repair, engine troubleshooting, and engine repairs.

Engine - D: Air filter replacement, oil changing, cooling system maintenance/repair, fuel system maintenance/repair, governor adjustment/repair, engine repair, engine troubleshooting, and engine repairs.

Manual Number - MM392

Revision: 03

Published: 5-02



CALIFORNIA PROPOSITION 65 WARNING:

Engine exhaust from this product contains chemicals known to the State of California to cause cancer, birth defects, or other reproductive harm.

CONTENTS

| | Page |
|--|------|
| SAFETY PRECAUTIONS | 1-3 |
| PUSHING OR TOWING MACHINE | 1-7 |
| TIEING DOWN MACHINE | 1-7 |
| MACHINE JACKING | 1-8 |
| STORING MACHINE | 1-8 |
| SPECIFICATIONS | 1-9 |
| GENERAL MACHINE PERFORMANCE .. | 1-9 |
| POWER TYPE | 1-10 |
| STEERING | 1-11 |
| HYDRAULIC SYSTEM | 1-11 |
| MAINTENANCE | 1-12 |
| MAINTENANCE CHART/GLP | 1-12 |
| MAINTENANCE CHART/D | 1-14 |
| HARDWARE INFORMATION | 1-16 |
| STANDARD BOLT TORQUE CHART | 1-16 |
| METRIC BOLT TORQUE CHART ... | 1-16 |
| BOLT IDENTIFICATION | 1-16 |
| THREAD SEALANT AND LOCKING COMPOUNDS | 1-16 |
| HYDRAULIC FITTING INFORMATION .. | 1-17 |
| HYDRAULIC TAPERED PIPE FITTING (NPT) TORQUE CHART | 1-17 |
| HYDRAULIC TAPERED SEAT FITTING (JIC) TORQUE CHART . | 1-17 |
| HYDRAULIC O-RING FITTING TORQUE CHART | 1-17 |

SAFETY PRECAUTIONS

The following precautions are used throughout this manual as indicated in their description:



WARNING: To warn of hazards or unsafe practices that could result in severe personal injury or death.

FOR SAFETY: To identify actions that must be followed for safe operation of equipment.

The machine is suited to sweep disposable debris. Do not use the machine other than described in this Operator Manual. The machine is not designed for use on public roads.



WARNING: Engine emits toxic gases. Severe respiratory damage or asphyxiation can result. Provide adequate ventilation. Consult with your regulatory authorities for exposure limits. Keep engine properly tuned.



WARNING: Raised hopper may fall. Engage hopper support bar.



WARNING: Lift arm pinch point. Stay clear of hopper lift arms.



WARNING: Moving belt and fan. Keep away.



WARNING: Flammable materials can cause an explosion or fire. Do not use flammable materials in tank(s).



WARNING: Flammable materials or reactive metals can cause explosion or fire. Do not pick up.



WARNING: Strong vacuum. Keep away from fan inlet when fan is running.



WARNING: Hot bumper. Keep away.

The following information signals potentially dangerous conditions to the operator or equipment:

FOR SAFETY:

1. Do not operate machine:
 - Unless trained and authorized.
 - Unless operator manual is read and understood.
 - If it is not in proper operating condition.
 - In flammable or explosive areas unless designed for use in those areas.
 - In areas with possible falling objects unless equipped with overhead guard.
2. Before starting machine:
 - Check for fuel, oil, and liquid leaks.
 - Keep sparks and open flame away from refueling area.
 - Make sure all safety devices are in place and operate properly.
 - Check brakes and steering for proper operation.
3. When starting machine:
 - Keep foot on brake and directional pedal in neutral.
4. When using machine:
 - Use brakes to stop machine.
 - Go slow on inclines and slippery surfaces.
 - Use care when reversing machine.
 - Move machine with care when hopper is raised.
 - Make sure adequate clearance is available before raising hopper.
 - Do not carry passengers on machine.
 - Always follow safety and traffic rules.
 - Report machine damage or faulty operation immediately.
 - Follow mixing and handling instructions on chemical containers.
5. Before leaving or servicing machine:
 - Stop on level surface.
 - Set parking brake.
 - Turn off machine and remove key.

6. **When servicing machine:**
 - **Avoid moving parts. Do not wear loose jackets, shirts, or sleeves.**
 - **Block machine tires before jacking machine up.**
 - **Jack machine up at designated locations only. Block machine up with jack stands.**
 - **Use hoist or jack that will support the weight of the machine.**
 - **Wear eye and ear protection when using pressurized air or water.**
 - **Disconnect battery connections before working on machine.**
 - **Avoid contact with battery acid.**
 - **Avoid contact with hot engine coolant.**
 - **Allow engine to cool.**
 - **Keep flames and sparks away from fuel system service area. Keep area well ventilated.**
 - **Use cardboard to locate leaking hydraulic fluid under pressure.**
 - **Use Tennant supplied or approved replacement parts.**

7. **When loading/unloading machine onto/off truck or trailer:**
 - **Turn off machine.**
 - **Use truck or trailer that will support the weight of the machine.**
 - **Use winch. Do not drive the machine onto/off the truck or trailer unless the load height is 380 mm (15 in) or less from the ground.**
 - **Set parking brake after machine is loaded.**
 - **Block machine tires.**
 - **Tie machine down to truck or trailer.**

The following safety labels are mounted on the machine in the locations indicated. If these or any label becomes damaged or illegible, install a new label in its place.

EMISSIONS LABEL - LOCATED ON THE SIDE PANEL OF THE OPERATOR COMPARTMENT.

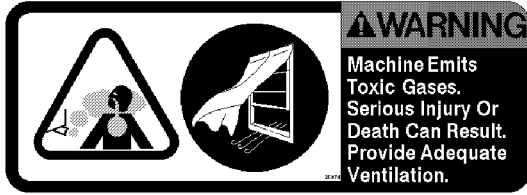

ENGINE FAN AND BELT LABEL - LOCATED ON THE RADIATOR SHROUD.



FOR SAFETY LABEL - LOCATED ON THE SIDE PANEL OF THE OPERATOR COMPARTMENT.

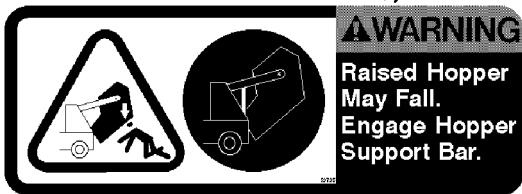
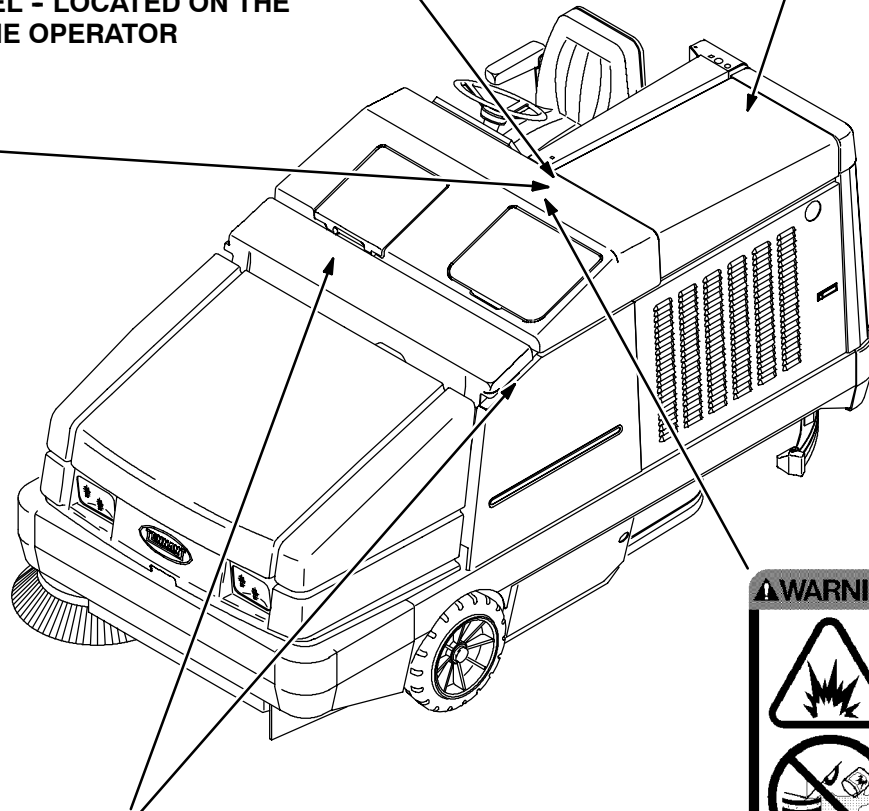
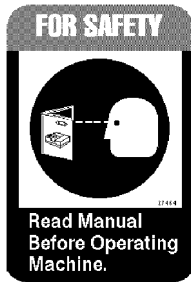

HOPPER SUPPORT BAR LABEL - LOCATED ON THE HOPPER SUPPORT BAR AND ON BOTH HOPPER LIFT ARMS.



FLAMMABLE SPILLS LABEL - LOCATED ON THE SIDE PANEL OF THE OPERATOR COMPARTMENT.

11047

GENERAL INFORMATION

FLAMMABLE MATERIALS LABEL - LOCATED ON THE SOLUTION TANK COVER.

STRONG VACUUM LABEL - LOCATED ON THE VACUUM FAN HOUSING.

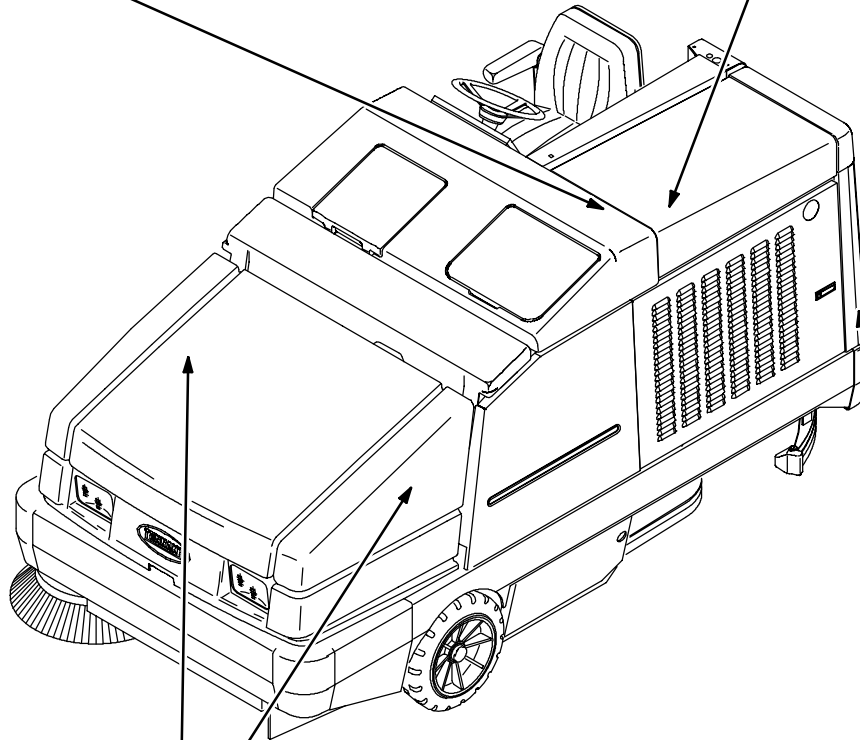
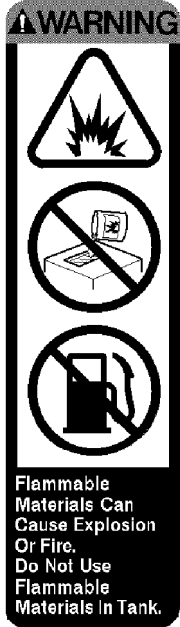

09078



HOPPER LIFT ARMS LABEL - LOCATED ON BOTH HOPPER LIFT ARMS.



HOT BUMPER LABEL - LOCATED ON THE REAR LEFT PANEL.

PUSHING, TOWING, AND TRANSPORTING THE MACHINE

PUSHING OR TOWING THE MACHINE

If the machine becomes disabled, it can be pushed from the front or rear, but towed only from the rear.

The propelling pump has a bypass valve to prevent damage to the hydraulic system when the machine is being pushed or towed. This valve allows a disabled machine to be moved for a *very short distance* and at a speed to not exceed 1.6 kp/h (1 mph). The machine is NOT intended to be pushed or towed a long distance or at a high speed.

ATTENTION! Do not push or tow machine for a long distance and without using the bypass valve, or the machine hydraulic system may be damaged.

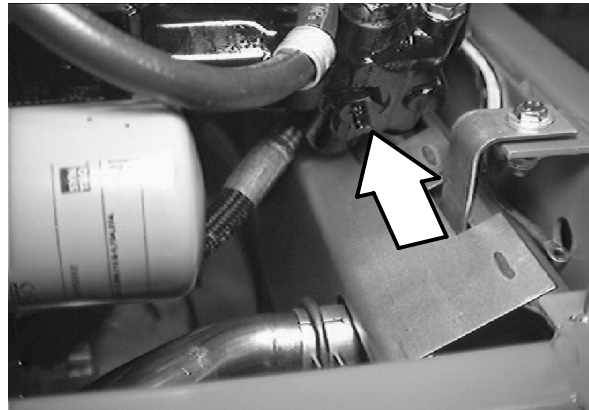

Turn the bypass valve 90° from the normal position before pushing or towing the machine. **The illustration shows the bypass valve in the pushing or towing position.**

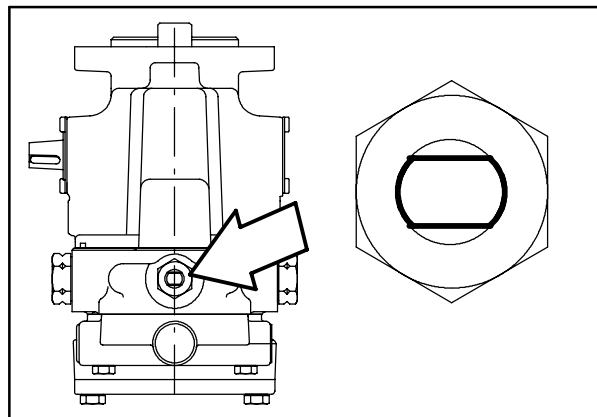

GENERAL INFORMATION

TRANSPORTING THE MACHINE

1. Position the rear of the machine at the loading edge of the truck or trailer.

FOR SAFETY: Use truck or trailer that will support the weight of the machine.

NOTE: Empty the hopper, recovery tank, and solution tank before transporting the machine.

2. If the loading surface is not horizontal or is higher than 380 mm (15 in) from the ground, use a winch to load machine.

If the loading surface is horizontal AND is 380 mm (15 in) or less from the ground, the machine may be driven onto the truck or trailer.

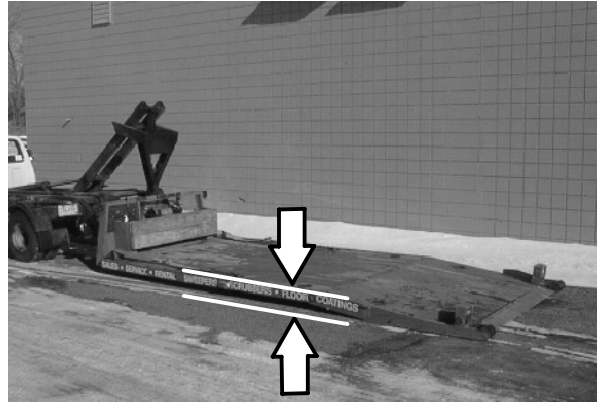

3. To winch the machine onto the truck or trailer, attach the winching chains in the holes at the bottom of the rear bumper.

 **WARNING: Hot bumper. Keep away.**

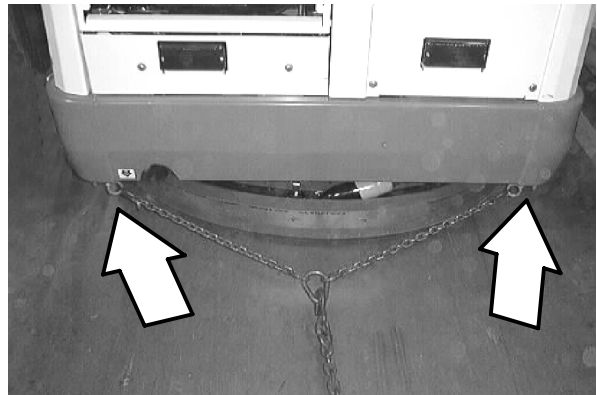

If the machine has the optional rear tie down brackets, attach the winching chains to them.

 **WARNING: Hot bumper. Keep away.**

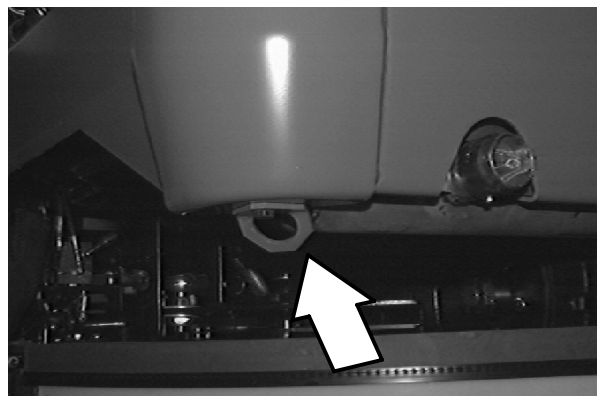

4. Turn the bypass valve 90° from the normal position before winching the machine onto the truck or trailer. See *PUSHING OR TOWING THE MACHINE* section of this manual. Make sure the machine is centered.

FOR SAFETY: When loading machine onto truck or trailer, use winch. Do not drive the machine onto the truck or trailer unless the loading surface is horizontal AND is 380 mm (15 in) or less from the ground.

5. Position the machine onto the truck or trailer as far as possible. If the machine starts to veer off the centerline of the truck or trailer, stop and turn the steering wheel to center the machine.
6. Set the parking brake, lower the scrub head and block the machine tires. Tie down the machine to the truck or trailer before transporting.

The front tie-down locations are the holes in the wheel pockets at the front of the machine frame.

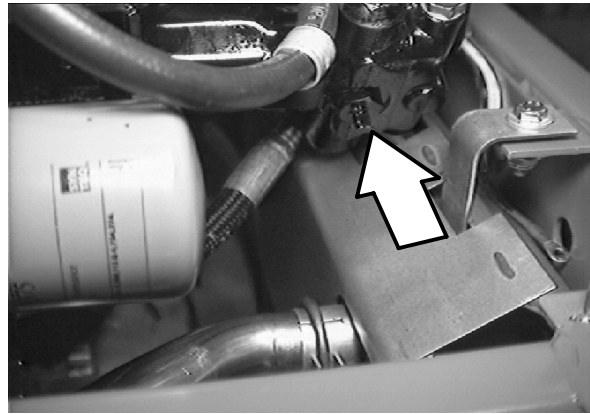

If the machine has the optional front tie down brackets above the front tires, attach the winching chains to them.

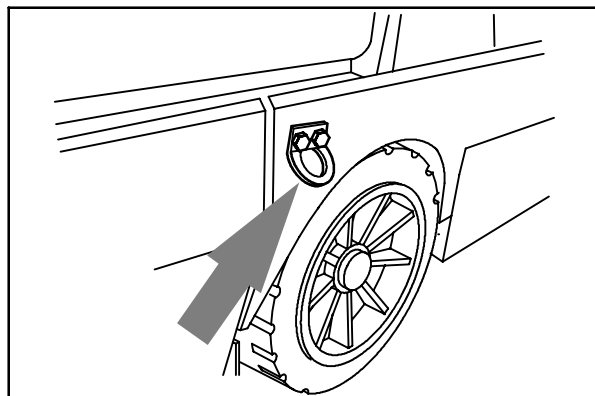

08152

GENERAL INFORMATION

The rear tie down locations are in the holes at the bottom of the rear bumper. If the machine has the optional rear tie down brackets, use them to tie down the machine.



WARNING: Hot bumper. Keep away.

7. If the loading surface is not horizontal or is higher than 380 mm (15 in) from the ground, use a winch to unload machine.

If the loading surface is horizontal AND is 380 mm (15 in) or less from the ground, the machine may be driven off the truck or trailer.

FOR SAFETY: When unloading machine off truck or trailer, use winch. Do not drive the machine off the truck or trailer unless the loading surface is horizontal AND 380 mm (15 in) or less from the ground.

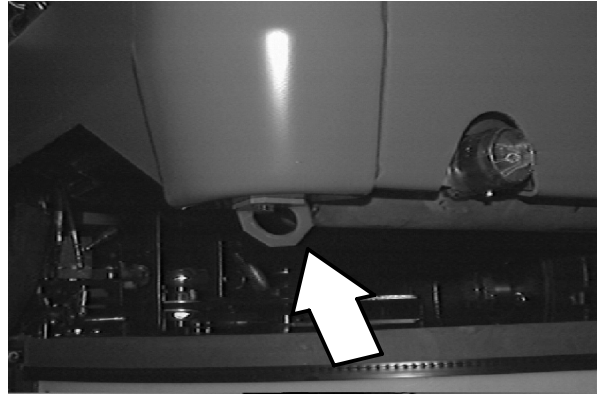

STORING MACHINE

Before storing the machine for an extended period of time, the machine needs to be prepped to lessen the chance of rust, sludge, and other undesirable deposits from forming. Contact TENNANT service personnel.

SPECIFICATIONS

GENERAL MACHINE DIMENSIONS/CAPACITIES

| Item | Dimension/capacity |
|--|--|
| Length, Gasoline | 2970 mm (117 in) |
| Length, LPG 15 kg (33 lb) tank | 3070 mm (121 in) |
| Length, LPG 19.5 kg (43 lb) tank | 3175 mm (125 in) |
| Length, Diesel | 2970 mm (117 in) |
| Width with side brush | 1610 mm (63.5 in) |
| Height | 1625 mm (64 in) |
| Height with overhead guard | 2125 mm (83.7 in) |
| Track | 1330 mm (52.38 in) |
| Wheelbase | 1625 mm (63.88 in) |
| Main sweeping brush diameter | 355 mm (14 in) |
| Main sweeping brush length | 1145 mm (45 in) |
| Scrub brush diameter | 405 mm (16 in) |
| Side brush diameter | 585 mm (23 in) |
| Sweeping path width | 1145 mm (45 in) |
| Sweeping path width with side brush | 1525 mm (60 in) |
| Squeegee width | 1490 mm (58.7 in) |
| Scrubbing path width | 1220 mm (48 in) |
| Main sweeping brush pattern width | 50 to 65 mm (2 to 2.5 in) |
| Hopper weight capacity | 545 kg (1200 lb) |
| Hopper volume capacity | 400 L (14 ft ³) |
| Dust filter area | 6.9 m ² (74 ft ²) |
| Solution tank | 227 L (60 gal) |
| Recovery tank | 227 L (60 gal) |
| Detergent tank (option) | 18.9 L (5 gal) |
| Total capacity with ES™ (option) | 379 L (100 gal) |
| GVWR | 3133 kg (6900 lb) |
| Ceiling height minimum dumping clearance | 2490 mm (98 in) |

GENERAL MACHINE PERFORMANCE

| Item | Measure |
|--|-------------------|
| Maximum forward speed | 12.9 km/h (8 mph) |
| Maximum reverse speed | 4.8 km/h (3 mph) |
| Minimum aisle turn width, left | 3530 mm (139 in) |
| Minimum turning radius, right | 3235 mm (128 in) |
| Minimum turning radius, left | 2270 mm (90 in) |
| Maximum rated incline for transport of machine | 8°/14.1% |
| Maximum rated incline for scrubbing/sweeping | 6°/10.5% |

GENERAL INFORMATION

POWER TYPE

| Engine | Type | Ignition | Cycle | Aspiration | Cylinders | Bore | Stroke |
|----------------|--------------------------------------|---------------|-----------------------------------|------------|---|---------------------------------------|----------------------|
| Kubota V2203-B | Piston | Diesel | 4 | Natural | 4 | 87 mm (3.34 in) | 92.4 mm (3.64 in) |
| | Displacement | | Net power, governed | | | Net power, maximum | |
| | 2200 cc (134.08 cu in) | | 32.8 kw (44 hp) @ 2400 rpm | | | 36.6 kw (49 hp) @ 2800 rpm | |
| | Fuel | | Cooling system | | | Electrical system | |
| | Diesel Fuel tank: 37.9 L (10 gal) | | Water/ethylene glycol antifreeze | | | 12 V nominal | |
| | | | Total: 17 L (4.5 gal) | | | 50 A alternator | |
| | | | Radiator: 6 L (1.6 gal) | | | | |
| | Idle speed, no load | | (Fast) governed speed, under load | | | Engine lubricating oil without filter | |
| 1500 ± 25 rpm | | 2400 ± 25 rpm | | | 6.15 L (6.5 qt) SAE-CC/CD rated engine oil | | |

| Engine | Displacement | | Net power, governed | | | | Net power, maximum | | |
|--------------------------------|---|----------------------------|----------------------------------|------------|-----------------------------|--------------------|--------------------------|--------------------|--|
| Ford LRG 2.3 | 2300 cc (140 cu in) | | 37.3 kw (50 hp) @ 2400 rpm | | | | 47 kw (63 hp) @ 2800 rpm | | |
| Ford LRG 2.5 | 2500 cc (152 cu in) | | 40.3 kw (54 hp) @ 2400 rpm | | | | 59 kw (79 hp) @ 3000 rpm | | |
| Ford LRG 2.3 and LRG 2.5 | Type | Ignition | Cycle | Aspiration | Cyl | Bore | LRG 2.3 Stroke | LRG 2.5 Stroke | |
| | Piston | Distributerless-type spark | 4 | Natural | 4 | 96 mm (3.78 in) | 80 mm (3.126 in) | 96 mm (3.78 in) | |
| | Fuel | | Cooling system | | | | Electrical system | | |
| | Gasoline, 87 octane minimum, unleaded. Fuel tank: 45.5 L (12 gal) | | Water/ethylene glycol antifreeze | | | | 12 V nominal | | |
| | LPG, Fuel tank: 15 kg (33 lb) Fuel tank: 19.5 kg (43 lb) | | Total: 16.7 L (4.4 gal) | | | | 50 A alternator | | |
| | | | Radiator: 6.2 L (1.6 gal) | | | | | | |
| | (Start) governed speed | | (Low) governed speed | | | | (High) governed speed | | |
| | 1475 ± 50 rpm | | 2000 ± 50 rpm | | | | 2400 ± 50 rpm | | |
| | Spark plug gap | | | | | Firing order | | | |
| | 1 to 1.1 mm (0.042 to 0.046 in) | | | | | 1-3-4-2 | | | |
| | Engine lubricating oil with filter (10W30 SAE-SG/SH) | | | | | | | | |
| Ford LRG 2.5 - 4.26 L (4.5 qt) | | | | | Ford LRG 2.3 - 4.7 L (5 qt) | | | | |

STEERING

| Type | Power source | Emergency steering |
|--|--------------------------|--------------------|
| Rear wheel, hydraulic cylinder and rotary valve controlled | Hydraulic accessory pump | Manual |

HYDRAULIC SYSTEM

| System | Capacity | Fluid Type |
|---------------------|-----------------|---|
| Hydraulic reservoir | 37.8 L (10 gal) | TENNANT part no. 65869 - above 7° C (45° F) |
| Hydraulic total | 53 L (14 gal) | TENNANT part no. 65870 - below 7° C (45° F) |

BRAKING SYSTEM

| Type | Operation |
|----------------|---|
| Service brakes | Mechanical drum brakes (2), one per front wheel, cable actuated |
| Parking brake | Utilize service brakes, cable actuated |

TIRES

| Location | Type | Size | Pressure |
|-----------|-------|-----------|----------|
| Front (2) | Solid | 5 x 18 in | - |
| Rear (1) | Solid | 6 x 18 in | - |

GENERAL INFORMATION

MAINTENANCE

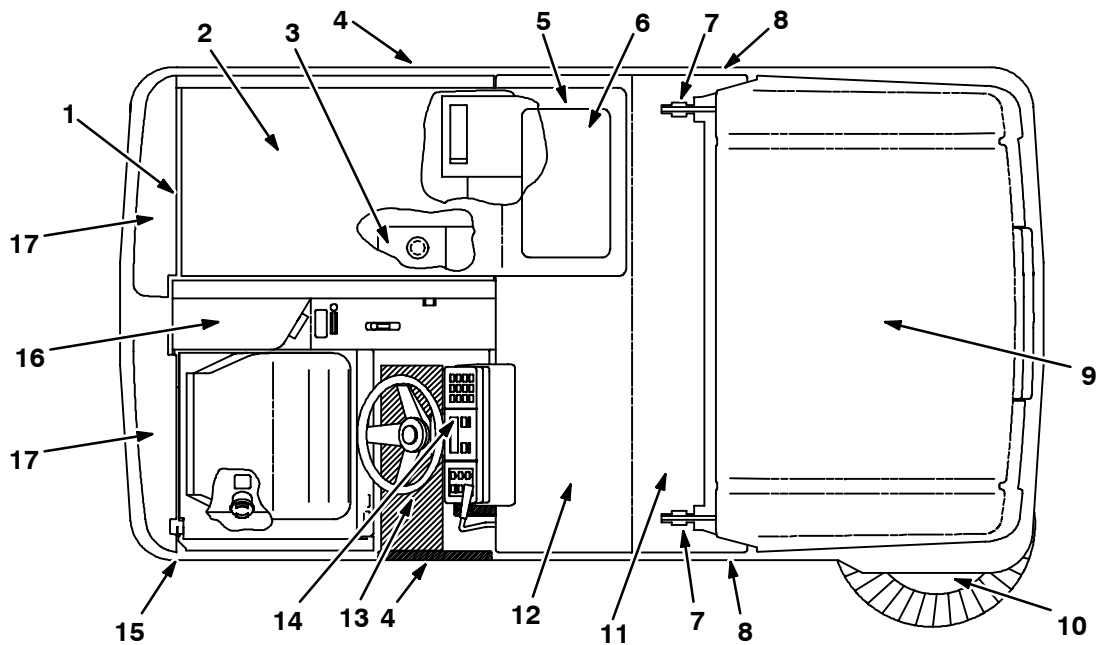

MAINTENANCE CHART G/LP

| Interval | Key | Description | Procedure | Lubricant/ Fluid | No. of Service Points |
|-----------|-------------------------|--------------------------|--|---------------------|-----------------------------|
| Daily | 2 | Engine air filter | Check indicator | - | 1 |
| | | | Empty dust cap | - | 1 |
| | 2 | Engine crankcase | Check oil level | EO | 1 |
| | 11 | Brush compartment skirts | Check for damage, wear and adjustment | - | 5 |
| | 9 | Hopper lip skirts | Check for damage, wear and adjustment | - | 3 |
| | 11 | Main sweep brush | Check for damage, wear, and adjustment | - | 1 |
| | | | Check brush pattern | - | 1 |
| | 10 | Side brush | Check for damage, wear, and adjustment | - | 1 |
| | | | Check brush pattern | - | 1 |
| | 9 | Hopper dust filter | Shake | - | 2 |
| | 15 | Rear Squeegee | Check for damage and wear | - | 1 |
| | | | Check deflection | - | 1 |
| | 4 | Side Squeegees | Check for damage and wear | - | 2 |
| | 4 | Scrub brushes | Check for damage and wear | - | 1 |
| | 5 | Recovery tank | Clean | - | 1 |
| 12 | Recovery tank, ES™ mode | Clean ES™ filter | - | 1 | |
| 6 | Solution tank, ES™ mode | Clean | - | 1 | |
| 50 Hours | 11 | Main sweep brush | Rotate end-for-end | - | 1 |
| | 17 | Rear squeegee casters | Lubricate | SPL | 2 |
| 100 Hours | 1 | Radiator | Clean core exterior | - | 1 |
| | | | Check coolant level | WG | 1 |
| | 2 | Engine crankcase | Change oil and filter element | EO | 1 |

GENERAL INFORMATION

| Interval | Key | Description | Procedure | Lubricant/ Fluid | No. of Service Points |
|------------------------------|--------------------|--------------------------------------|---|---------------------|-----------------------------|
| 100 Hours | 2 | Engine | Check belt tension | - | 1 |
| | | | Check and adjust idle speed | - | 1 |
| | | | Check and adjust idle mixture | - | 1 |
| | 9 | Hopper dust filter | Check for damage, clean or re- place | - | 1 |
| | 3 | Hydraulic fluid reservoir | Check fluid level | HYDO | 1 |
| | 8 | Tires | Check for damage | - | 3 |
| | 11 | Main sweep brush and hopper seals | Check for damage or wear | - | 8 |
| 200 Hours | 15 | Rear squeegee | Check leveling | - | 1 |
| | 1 | Radiator hoses and clamps | Check for tightness and wear | - | 2 |
| | | 14 | Parking brake | Check adjustment | - |
| | 14 | Brake pedal | Check and adjust travel | - | 1 |
| | 16 | Rear wheel support bear- ings | Lubricate | SPL | 2 |
| | 10 | Side brush guard | Rotate 90° | - | 1 |
| | 7 | Lift arm pivots | Lubricate | SPL | 4 |
| 9 | Hopper door pivots | Lubricate | SPL | 2 | |
| 400 Hours | 8 | Front wheel bearings | Check, lubricate, and adjust | SPL | 2 |
| | 1 | Cooling system | Flush | WG | 1 |
| | 2 | Engine | Clean or replace and adjust spark plugs | - | 4 |
| | | | Replace PCV valve | - | 1 |
| | | | Fuel filter, gasoline | - | 2 |
| | | | Replace suction strainer | - | 1 |
| | | | Change hydraulic fluid | HYDO | 1 |
| | 3 | Hydraulic fluid filter | Change filter element | - | 1 |
| | - | Hydraulic hoses | Check for wear and damage | - | All |
| | 16 | Propelling motor | ■Torque shaft nut | - | 1 |
| | 16 | Rear wheel | ■Torque wheel nuts | - | 1 |
| | 13 | Battery | ■Clean and tighten battery cable connections | - | 1 |
| | | | Check electrolyte | DW | 1 |
| | 2 | Engine | Clean PCV hoses, tubes, and fit- tings | - | 1 |
| Torque intake manifold bolts | | | - | 8 | |
| Check timing belt | | | - | 1 | |
| 1600 Hours | 2 | Engine | Replace timing belt | - | 1 |

LUBRICANT/FLUID

EO Engine oil, SAE-SG/SH rated

HYDO . . . Tennant or approved hydraulic fluid

WG Water and permanent-type ethylene glycol anti-freeze, -34° C (-30° F)

SPL Special lubricant, Lubriplate EMB grease (Tennant part number 01433-1)

DW Distilled water

NOTE: Also check procedures indicted (■) after the first 50-hours of operation.

NOTE: More frequent intervals may be required in extremely dusty conditions.

GENERAL INFORMATION

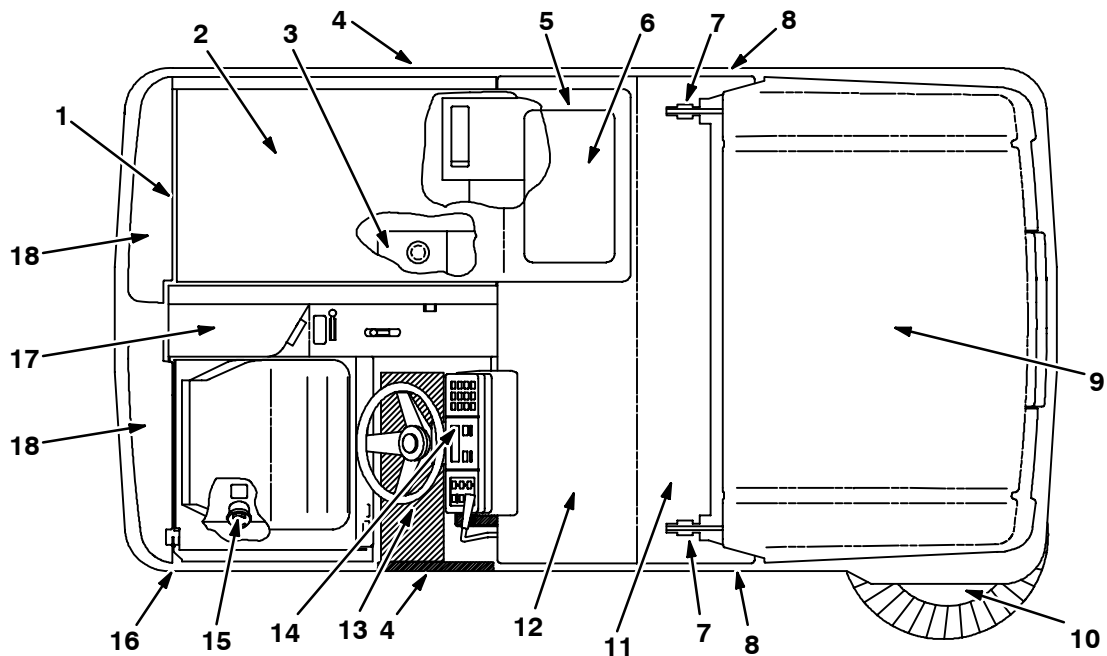

MAINTENANCE CHART Diesel

| Interval | Key | Description | Procedure | Lubricant/ Fluid | No. of Service Points |
|----------|-------------------------|--------------------------|--|---------------------|-----------------------------|
| Daily | 2 | Engine air filter | Check indicator | - | 1 |
| | | | Empty dust cap | - | 1 |
| | 2 | Engine crankcase | Check oil level | EO | 1 |
| | 11 | Brush compartment skirts | Check for damage, wear and adjustment | - | 5 |
| | 9 | Hopper lip skirts | Check for damage, wear and adjustment | - | 3 |
| | 11 | Main sweep brush | Check for damage, wear, and adjustment | - | 1 |
| | | | Check brush pattern | - | 1 |
| | 10 | Side brush | Check for damage, wear, and adjustment | - | 1 |
| | | | Check brush pattern | - | 1 |
| | 9 | Hopper dust filter | Shake | - | 2 |
| | 16 | Rear Squeegee | Check for damage and wear | - | 1 |
| | | | Check deflection | - | 1 |
| | 4 | Side Squeegees | Check for damage and wear | - | 2 |
| | 4 | Scrub brushes | Check for damage and wear | - | 1 |
| 5 | Recovery tank | Clean | - | 1 | |
| 12 | Recovery tank, ES™ mode | Clean ES™ filter | - | 1 | |
| 6 | Solution tank, ES™ mode | Clean | - | 1 | |
| 50 Hours | 11 | Main sweep brush | Rotate end-for-end | - | 1 |
| | 2 | Fuel pipes and clamps | Check for tightness and wear | - | 1 |
| | 2 | Engine crankcase | Change oil and filter | EO | 1 |
| | 18 | Rear squeegee casters | Lubricate | SPL | 2 |

GENERAL INFORMATION

| Interval | Key | Description | Procedure | Lubricant/ Fluid | No. of Service Points |
|-----------|--------------------|--------------------------------------|---|---------------------|-----------------------------|
| 100 Hours | 1 | Radiator | Clean core exterior | - | 1 |
| | | | Check coolant level | WG | 1 |
| | 2 | Engine belt | Check tension | - | 1 |
| | 9 | Hopper dust filter | Check for damage, clean or re- place | - | 1 |
| | 3 | Hydraulic fluid reservoir | Check fluid level | HYDO | 1 |
| | 8 | Tires | Check for damage | - | 3 |
| | 11 | Main sweep brush and hopper seals | Check for damage or wear | - | 8 |
| 200 Hours | 16 | Rear squeegee | Check leveling | - | 1 |
| | 1 | Radiator hoses and clamps | Check for tightness and wear | - | 2 |
| | | | 14 | Parking brake | Check adjustment |
| | 14 | Brake pedal | Check and adjust travel | - | 1 |
| | 17 | Rear wheel support bear- ings | Lubricate | SPL | 2 |
| | 10 | Side brush guard | Rotate 90° | - | 1 |
| | 7 | Lift arm pivots | Lubricate | SPL | 4 |
| 9 | Hopper door pivots | Lubricate | SPL | 2 | |
| 400 Hours | 8 | Front wheel bearings | Check, lubricate, and adjust | SPL | 2 |
| | 2 | Fuel filter | Replace cartridge | - | 1 |
| | 15 | Fuel tank | Remove sediment | - | 1 |
| | 1 | Cooling system | Flush | WG | 1 |
| 800 Hours | 3 | Hydraulic reservoir | Replace filler cap | - | 1 |
| | | | Replace suction strainer | - | 1 |
| | | | Change hydraulic fluid | HYDO | 1 |
| | 3 | Hydraulic fluid filter | Change filter element | - | 1 |
| | - | Hydraulic hoses | Check for wear and damage | - | All |
| | 17 | Propelling motor | ■Torque shaft nut | - | 1 |
| | 17 | Rear wheel | ■Torque wheel nuts | - | 1 |
| | 13 | Battery | ■Clean and tighten battery cable connections | - | 1 |
| | | | Check electrolyte | DW | 1 |

LUBRICANT/FLUID

EO . . . Engine oil, SAE-CC/CD rated

HYDO . Tennant Company or approved hydraulic fluid

WG . . . Water and permanent-type ethylene glycol anti-freeze, -34° C (-30° F)

SPL . . . Special lubricant, Lubriplate EMB grease (Tennant part number 01433-1)

DW . . . Distilled water

*NOTE: Also check procedures indicted (■) after
the first 50-hours of operation.*

*NOTE: More frequent intervals may be required
in extremely dusty conditions.*

GENERAL INFORMATION

HARDWARE INFORMATION

The following charts state standard plated hardware tightening ranges for normal assembly applications. Decrease the specified torque by 20% when using a thread lubricant. Do not substitute lower grade hardware for higher grade hardware. If higher grade hardware than specified is substituted, tighten only to the specified hardware torque value to avoid damaging the threads of the part being threaded into, as when threading into speed nuts or weldments.

STANDARD BOLT TORQUE CHART

| Thread Size | SAE Grade 5 Torque ft lb (Nm) | SAE Grade 8 Torque ft lb (Nm) |
|-------------|-------------------------------|-------------------------------|
| 0.25 in | 7-10 (9-14) | 10-13 (14-38) |
| 0.31 in | 15-20 (20-27) | 20-26 (27-35) |
| 0.38 in | 27-35 (37-47) | 36-47 (49-64) |
| 0.44 in | 43-56 (58-76) | 53-76 (72-103) |
| 0.50 in | 65-85 (88-115) | 89-116 (121-157) |
| 0.62 in | 130-170 (176-231) | 117-265 (159-359) |
| 0.75 in | 215-280 (291-380) | 313-407 (424-552) |
| 1.00 in | 500-650 (678-881) | 757-984 (1026-1334) |

NOTE: Decrease torque by 20% when using a thread lubricant.

METRIC BOLT TORQUE CHART





| Thread Size | Class 8.8 Torque ft lb (Nm) | Class 10.9 Torque ft lb (Nm) |
|-------------|-----------------------------|------------------------------|
| M4 | 2 (3) | 3 (4) |
| M5 | 4 (5) | 6 (8) |
| M6 | 7 (9) | 10 (14) |
| M8 | 18 (24) | 25 (34) |
| M10 | 32 (43) | 47 (64) |
| M12 | 58 (79) | 83 (112) |
| M14 | 94 (127) | 133 (180) |
| M16 | 144 (195) | 196 (265) |
| M20 | 260 (352) | 336 (455) |
| M24 | 470 (637) | 664 (900) |

NOTE: Decrease torque by 20% when using a thread lubricant.

Exceptions to the above chart:

Check the machine for exceptions!

BOLT IDENTIFICATION

| Identification Grade Marking | Specification and Grade |
|--|-------------------------|
|  | SAE-Grade 5 |
|  | SAE-Grade 8 |
|  | ISO-Grade 8.8 |
|  | ISO-Grade 10.9 |

01395

THREAD SEALANT AND LOCKING COMPOUNDS

Thread sealants and locking compounds may be used on this machine. They include the following:

Loctite 515 sealant – gasket forming material. TENNANT Part No. 75567, 15 oz (440 ml) cartridge.

Loctite 242 blue – medium strength thread locking compound. TENNANT Part No. 32676, 0.5 ml tube.

Loctite 271 red – high strength thread locking compound. TENNANT Part No. 19857, 0.5 ml tube.

HYDRAULIC FITTING INFORMATION

**HYDRAULIC TAPERED PIPE FITTING (NPT)
TORQUE CHART**

NOTE: Ratings listed are when using teflon thread seal.

| Size | Minimum Torque | Maximum Torque |
|---------|------------------|--------------------|
| 1/4 NPT | 10 ft lb (14 Nm) | 30 ft lb (41 Nm) |
| 1/2 NPT | 25 ft lb (34 Nm) | 50 ft lb (68 Nm) |
| 3/4 NPT | 50 ft lb (68 Nm) | 100 ft lb (136 Nm) |

**HYDRAULIC TAPERED SEAT FITTING (JIC)
TORQUE CHART**

| Tube O.D. (in) | Thread Size | Maximum Torque |
|----------------|-------------|-------------------|
| 0.25 | 0.44-20 | 9 ft lb (12 Nm) |
| 0.38 | 0.56-18 | 20 ft lb (27 Nm) |
| 0.50 | 0.75-16 | 30 ft lb (41 Nm) |
| 0.62 | 0.88-14 | 40 ft lb (54 Nm) |
| 0.75 | 1.12-12 | 70 ft lb (95 Nm) |
| 1.0 | 1.31-12 | 90 ft lb (122 Nm) |

**HYDRAULIC O-RING FITTING TORQUE
CHART**

| Tube O.D. (in) | Thread Size | Minimum Torque | Maximum Torque |
|----------------|-------------|-------------------|-------------------|
| 0.25 | 0.44-20 | 6 ft lb (8 Nm) | 9 ft lb (12 Nm) |
| 0.38 | 0.56-18 | 13 ft lb (18 Nm) | 20 ft lb (27 Nm) |
| | | *10 ft lb (14 Nm) | 12 ft lb (16 Nm) |
| 0.50 | 0.75-16 | 20 ft lb (27 Nm) | 30 ft lb (41 Nm) |
| | | *21 ft lb (28 Nm) | 24 ft lb (33 Nm) |
| 0.62 | 0.88-14 | 25 ft lb (34 Nm) | 40 ft lb (54 Nm) |
| 0.75 | 1.12-12 | 45 ft lb (61 Nm) | 70 ft lb (95 Nm) |
| 1.0 | 1.31-12 | 60 ft lb (81 Nm) | 90 ft lb (122 Nm) |

NOTE: Do not use sealant on o-ring threads.

*Aluminum bodied components

CONTENTS

| | Page |
|---|------|
| INTRODUCTION | 2-3 |
| SEAT | 2-4 |
| TO REMOVE SEAT ASSEMBLY .. | 2-4 |
| TO REPLACE SEAT ASSEMBLY .. | 2-4 |
| TO ADJUST SEAT POSITION | 2-5 |
| STATIC DRAG CHAIN | 2-5 |
| BRAKES AND TIRES | 2-6 |
| SERVICE BRAKES | 2-6 |
| TO REPLACE BRAKE SHOES | 2-6 |
| PARKING BRAKE LEVER | 2-8 |
| FRONT TIRES AND WHEELS | 2-9 |
| TO REPACK FRONT WHEEL BEARINGS | 2-9 |
| REAR WHEEL AND WHEEL SUPPORT | 2-11 |
| TO REPLACE REAR WHEEL HOUSING PIVOT BEARINGS . | 2-12 |

INTRODUCTION

This section includes information on the main chassis related components for example the seat, steering, brakes and tires.

SEAT

The seat assembly is removable and adjustable on the 8400.

The operator seat is a fixed back style with a forward-backward adjustment.

TO REMOVE SEAT ASSEMBLY

FOR SAFETY: Before Leaving Or Servicing Machine; Stop On Level Surface, Set Parking Brake, Turn Off Machine And Remove Key.

1. Tilt the seat assembly forward.
2. Slide the seat prop rod up and out of the rod slot.
3. Pull the hair cotter pin out of the pivot shaft.
4. Lift and slide the seat sideways off the machine.

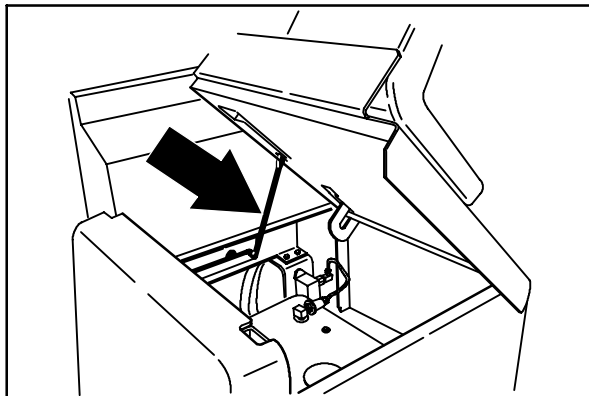

TO REPLACE SEAT ASSEMBLY

FOR SAFETY: Before Leaving Or Servicing Machine; Stop On Level Surface, Set Parking Brake, Turn Off Machine And Remove Key.

1. Slide the seat assembly pins in the pivot holes on the seat support.
2. Slide the hair cotter pin in the hole on the pivot shaft to secure the seat.
3. Slide the seat rod through the large hole in the slot.
4. Lower the seat.

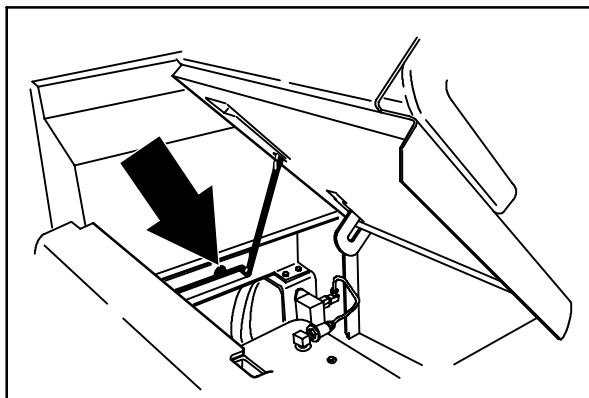

TO ADJUST SEAT POSITION

FOR SAFETY: Before Leaving Or Servicing Machine; Stop On Level Surface, Set Parking Brake, Turn Off Machine And Remove Key.

1. Pull the lever out, slide the seat backward or forward to the desired position and release the lever.

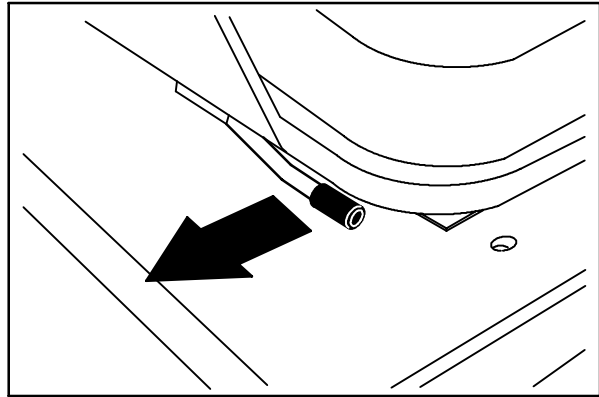

STATIC DRAG CHAIN

A static drag chain prevents the buildup of static electricity in the machine. The chain is attached to the machine by a rear main brush skirt retaining bolt.

Make sure the chain is touching the floor at all times.

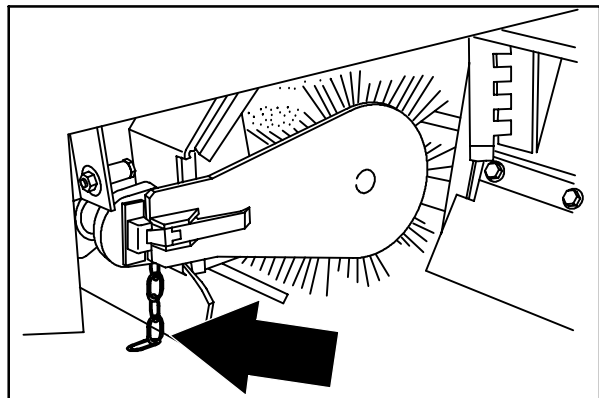

BRAKES AND TIRES

SERVICE BRAKES

The mechanical service brakes are located on the front wheels. The brakes are operated by the foot brake pedal and connecting cables.

Check the brake adjustment every 200 hours of operation.

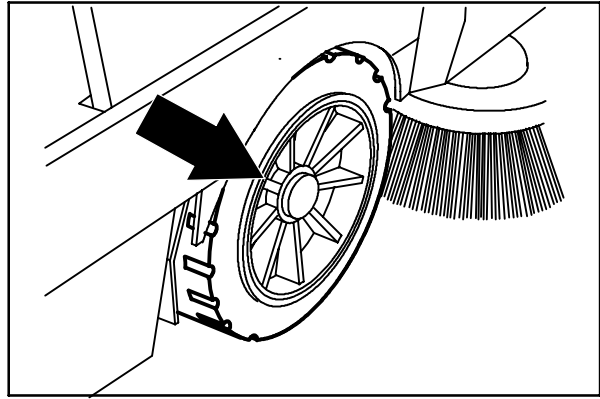

TO REPLACE BRAKE SHOES

FOR SAFETY: Before Leaving Or Servicing Machine; Stop On Level Surface, Set Parking Brake, Turn Off Machine And Remove Key.

1. Empty the debris hopper.
2. Turn the parking brake knurled knob counterclockwise until it stops. (early version machines only)
3. Disconnect the battery cables and remove the battery to access the floor plate hardware.
4. Remove floor plate from the machine.
5. Thread the brake cable clevis yoke toward the threaded rod to reduce brake cable tension.

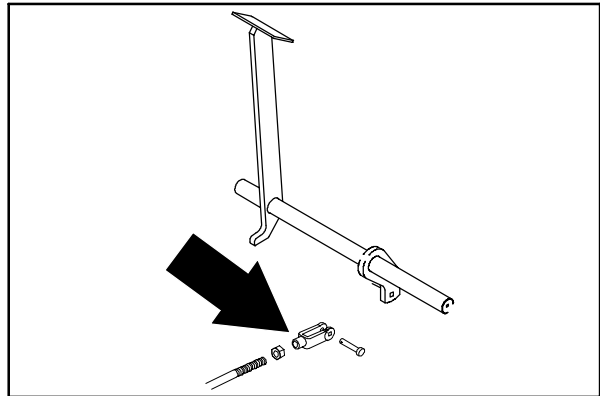
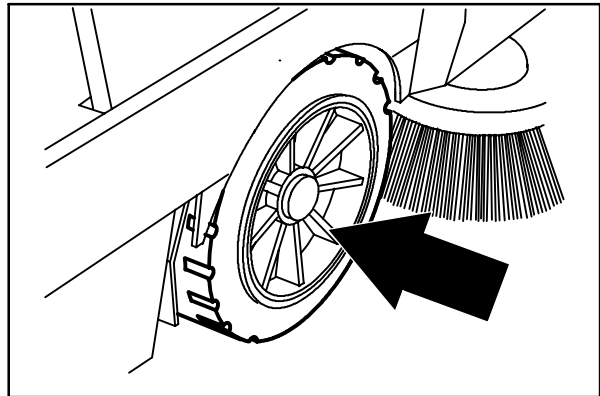

6. Jack up one front corner of the machine. Place jack stands under machine.
7. Remove the hub cap.
8. Remove the cotter pin, slotted nut, flat washer, and bearing cone.
9. Remove the front tire and wheel assembly from the machine.
10. Remove the two springs holding the brake shoes together. Remove the old brake shoes from the machine.

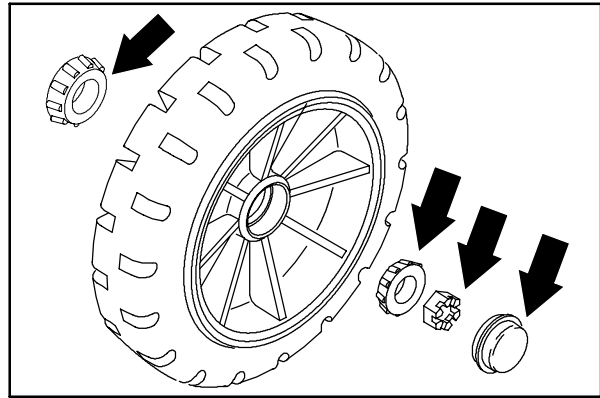

11. Position the new brake shoes on the machine.

NOTE: Always replace brake shoes in sets.

12. Reattach brake springs to the new brake shoes.
13. Pack the wheel bearings with Lubriplate EMB grease.
14. Slide the wheel on the axle.
15. Slide the outer bearing, flat washer and nut on the shaft.
16. Tighten nut with hand wrench until wheel binds, then back the nut off to nearest hole.
17. Insert a new cotter pin through nut and hole.
18. After making sure the wheel spins freely, carefully install the hub cap.
19. Remove the jack stand and lower the machine. Repeat this procedure on the opposite side.

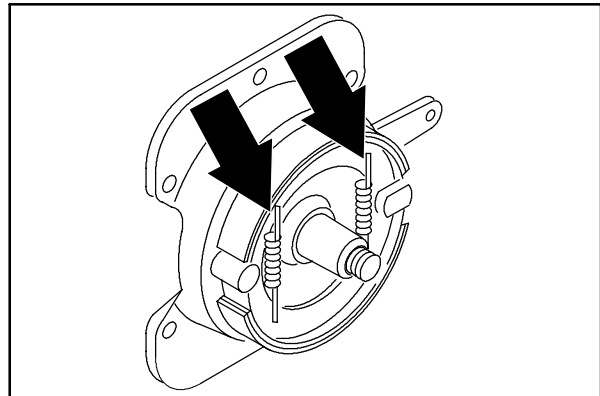

NOTE: Always replace brake shoes in sets.

20. Thread the brake cable clevis yoke away from the threaded rod until the brake pedal travels 25–50 mm (1–2 in) before engaging brakes.

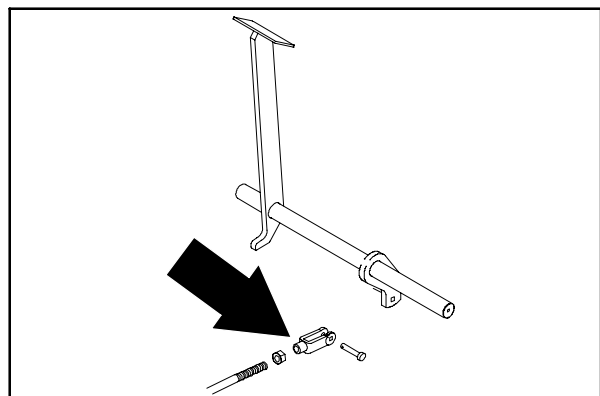
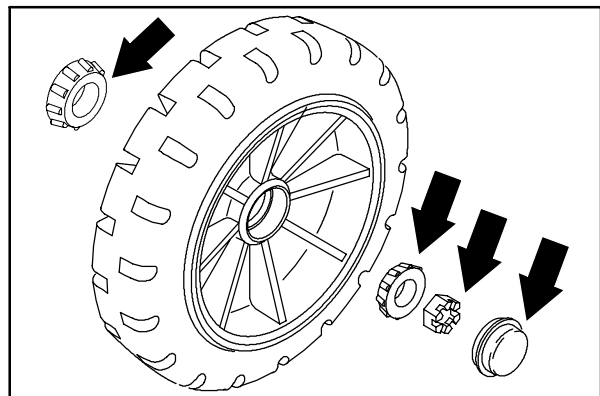

CHASSIS

21. Tighten the brake clevis jam nuts.
22. Reinstall the floor plate.
23. Install the battery and battery cables.
24. Lower the seat support.
25. Adjust the parking brake by turning the knurled knob clockwise until the parking brake properly holds the machine in place. (early version machines only).
26. Drive the machine and check the brakes for proper operation.

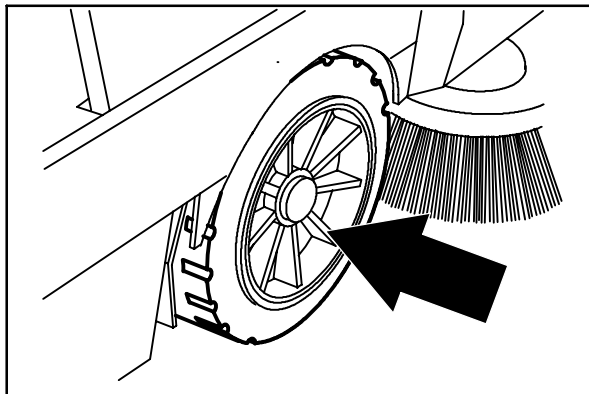

PARKING BRAKE LEVER

The parking brake lever sets and releases the front wheel brakes.

Set: Move the brake lever from the short to the long slot with your foot. Step on the brake pedal to lock the pedal in place.

Release: Step on the brake pedal to release it, and move the brake lever to the left with your foot at the same time. Lock the lever in place in the short slot.

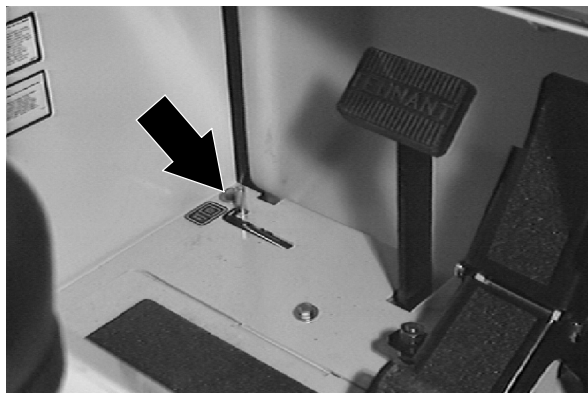

FRONT TIRES AND WHEELS

The machines front tires are semi-pneumatic.

Inspect the front wheel bearings for seal damage, and repack and adjust every 1600 hours of operation. Use Lubriplate EMB grease (TENNANT part no. 01433-1).

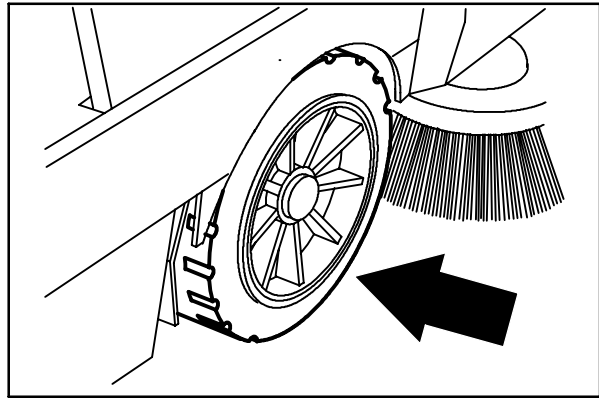

TO REPACK FRONT WHEEL BEARINGS

FOR SAFETY: Before Leaving Or Servicing Machine; Stop On Level Surface, Set Parking Brake, Turn Off Machine And Remove Key.

1. Empty the debris hopper.
2. Turn the parking brake knurled knob counterclockwise until it stops. (early version machines only)
3. Disconnect the battery cables and remove the battery to access the floor plate hardware.
4. Remove floor plate from the machine.
5. Thread the brake cable clevis yoke toward the threaded rod to reduce brake cable tension.
6. Jack up one front corner of the machine. Place jack stands under machine.
7. Remove the hub cap.
8. Remove the cotter pin, slotted nut, flat washer, and bearing cone.
9. Remove the front tire and wheel assembly from the machine.
10. Pack the wheel bearings with Lubriplate EMB grease.
11. Slide the wheel assembly back on the axle.
12. Slide the outer bearing, flat washer and nut onto the shaft.
13. Tighten the nut with hand wrench until the wheel binds, then back the nut off to the nearest hole.

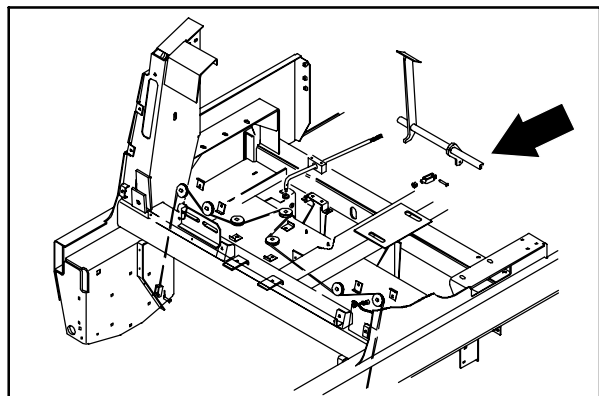
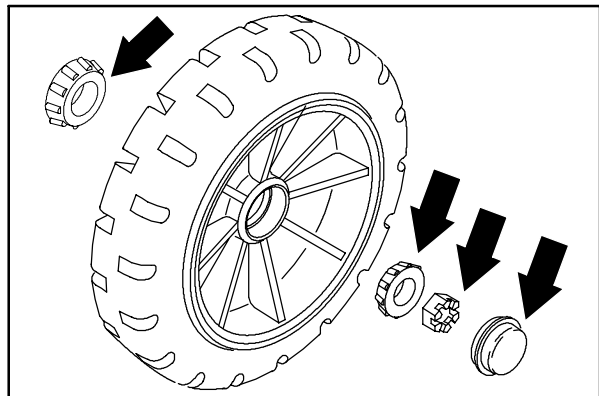
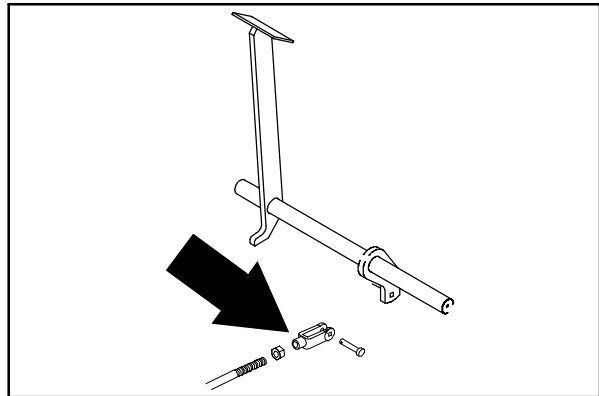

CHASSIS

14. Insert a new cotter pin through nut and hole.
15. After making sure the wheel spins freely, carefully install the hub cap. Repeat this procedure on the opposite side of the machine.
16. Remove the jack stand and lower the machine.
17. Thread the brake cable clevis yoke away from the threaded rod until the brake pedal travels 25–50 mm (1–2 in) before engaging brakes.
18. Tighten the brake clevis jam nuts.
19. Reinstall the floor plate.
20. Install the battery and battery cables.
21. Lower the seat support.
22. Adjust the parking brake by turning the knurled knob clockwise until the parking brake properly holds the machine in place. (early version machines only)
23. Drive the machine and check for proper operation.

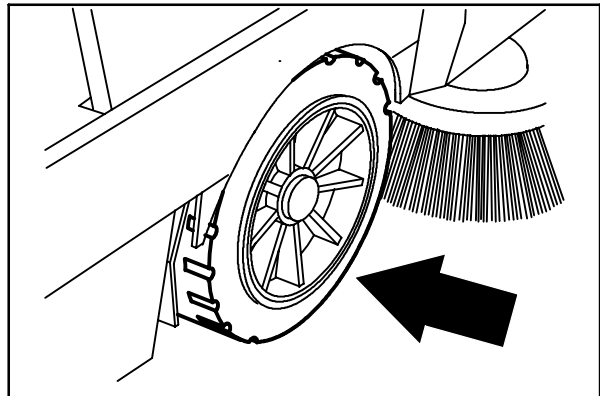
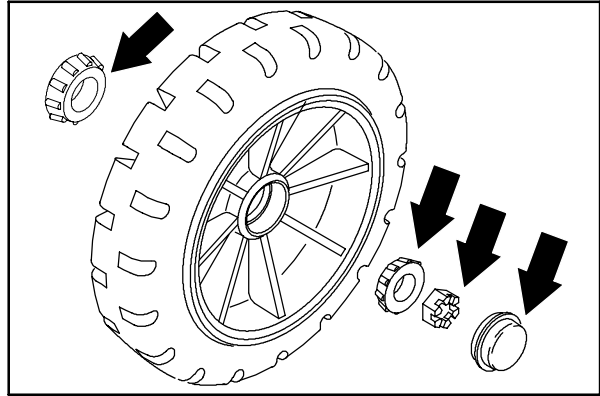

REAR WHEEL AND WHEEL SUPPORT

The rear wheel support pivots the rear wheel. The support has one grease fitting for the bearings. The rear wheel support bearings must be lubricated every 200 hours of operation. Use Lubriplate EMB grease (TENNANT part no. 01433-1).

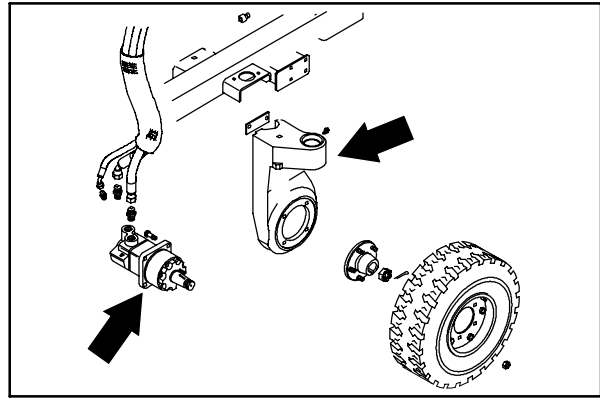

Torque the rear wheel nuts twice in the pattern shown to 142 - 156 Nm (105 - 115 ft lb) after the first 50-hours of operation, and every 800 hours thereafter. Torque the rear wheel hub nut to (375 ft lb).

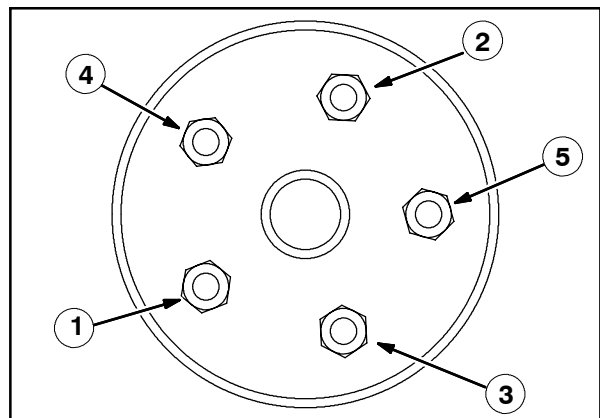

TO REPLACE REAR WHEEL HOUSING PIVOT BEARINGS

FOR SAFETY: Before Leaving Or Servicing Machine; Stop On Level Surface, Set Parking Brake, Turn Off Machine And Remove Key.

1. Engage the parking brake and block the front tires.
2. Jack up the rear of the machine. Use jack stands to support machine.

FOR SAFETY: Block machine tires before jacking machine up. Jack machine up at designated locations only. Block machine up with jack stands.

3. Remove the rear tire and wheel assembly.
4. Remove the slotted nut from drive wheel motor hub shaft.
5. Use a large puller to remove the drive hub from the motor shaft.
6. Remove the hose support plate from the rear wheel housing.

NOTE: The hydraulic hoses can remain connected to the drive motor

7. Remove the four drive motor mounting bolts.

NOTE: The orientation of the motor in the rear wheel housing.

8. Slide the motor out of the rear wheel housing.
9. The hydraulic motor can moved out of the way to ease rear wheel housing removal.

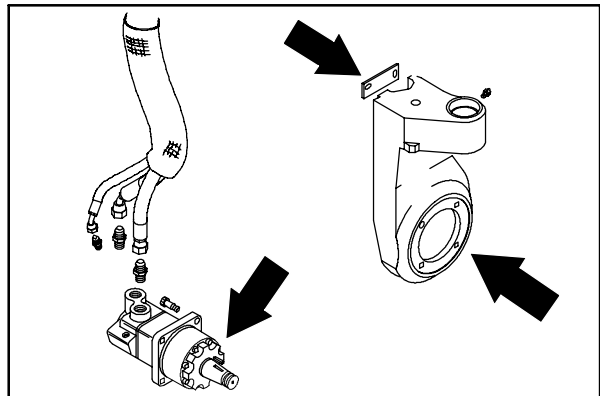
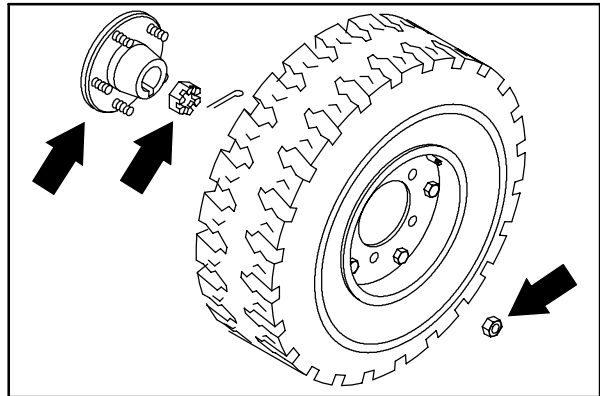
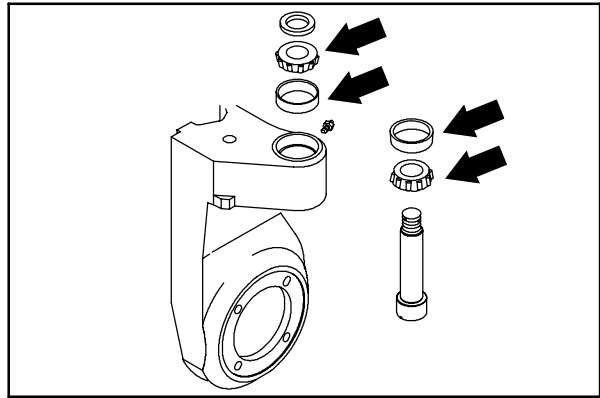

10. Remove .750 inch hex screw attaching rod end of steering cylinder to rear wheel housing.
11. Remove the cotter pin and large slotted nut from the top of the pivot pin.
12. Loosen the two M10 socket head bolts that are pinching the pivot pin in the frame.
13. Remove the pivot pin from the machine.

NOTE: The rear drive housing is heavy and will drop out of the machine frame when the pivot pin is removed.

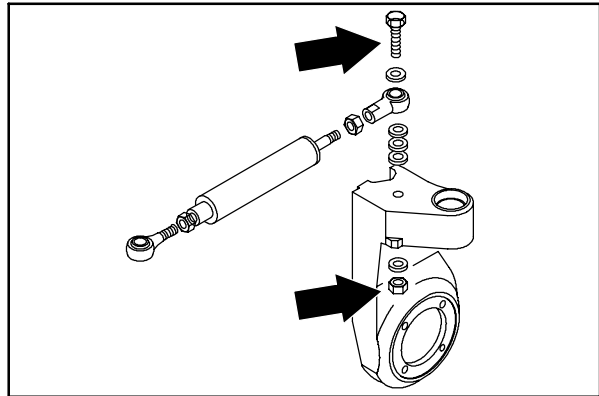

14. Slide the wheel housing out of the main frame. Retain the thrust washer that is in place on top of the upper bearing cone.
15. Remove and discard both bearing cones.
16. Remove and discard the pressed in bearing cups by tapping them out with a hammer and drift punch.
17. Press the new bearing cups in by using a hydraulic press.
18. Pack the new bearing cones with Lubriplate EMB grease. Coat the new bearing cups with grease also.
19. Position the new bearings in the wheel housing.
20. Position the thrust washer on top of top bearing cone.
21. Position the wheel housing back in the machine frame.
22. Slide the pivot pin up through the hole in the frame and through the two bearings. Thread the castle nut on the pin. Tighten to 34 - 40 Nm (25 - 30 ft lb). Check for play. If pin is not seated, tap with rubber mallet and re-torque castle nut.
23. Torque the top socket screw with hand torque wrench to 100 - 115 Nm (73-85 ft lb).

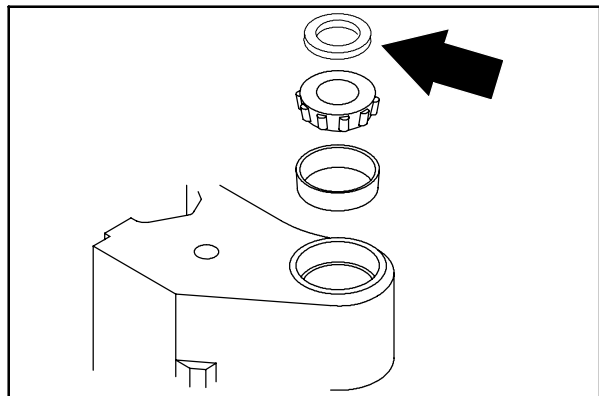
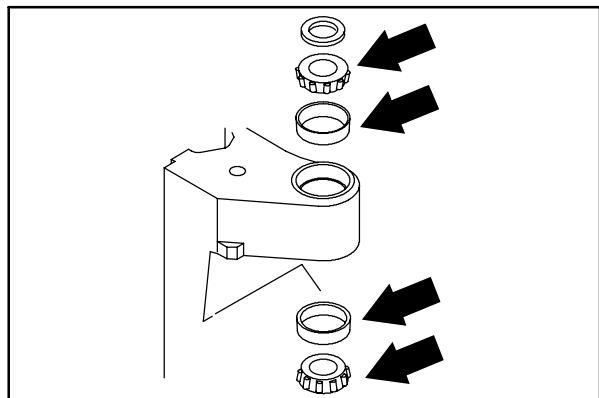
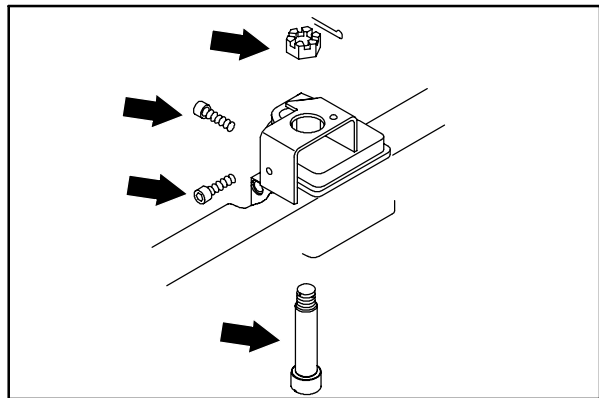

CHASSIS

24. Tighten the castle nut to the next slot and insert the cotter pin. Torque not to exceed 100 Nm (75 ft lb).
25. Check the casting to see if it rocks or binds. If it does, loosen the top socket screw, move the casting to seat bearing, and re-tighten the socket screw to 100 - 115 Nm (73-85 ft lb).
26. Tighten the lower socket screw to 100 - 115 Nm (73-85 ft lb).
27. Reconnect the rod end of the steering cylinder to wheel casting using the .750x3.25 hex screw, nyloc nut, and four washers. Tighten to 270 - 300 Nm (200 - 220 ft lb).
28. Slide the rear drive motor in the wheel housing.

NOTE: The orientation of the motor in the rear wheel housing.

29. Install the four socket screws. Torque to 90 - 117 Nm (70 - 85 ft lb).
30. Reinstall the hose clamp to the drive housing. Tighten M8 hex screws to 18.5 - 24Nm (15 - 20 ft lb).
31. Install the drive hub to the tapered motor shaft. Tighten slotted nut to 500 Nm (375 ft lb). Install the cotter pin.

NOTE: Make sure the square key is in place on the tapered shaft before installing the drive hub.

32. Install rear tire and wheel assembly. Torque the rear wheel nuts to 142 - 156 Nm (105 - 115 ft lb).
33. Re-connect battery cables, start engine, run propelling in both directions, check for leaks.
34. Remove the jack stands and lower the machine.
35. Drive the machine and check for proper operation.

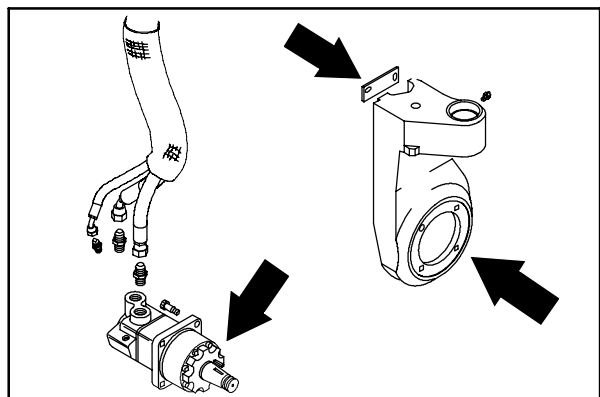
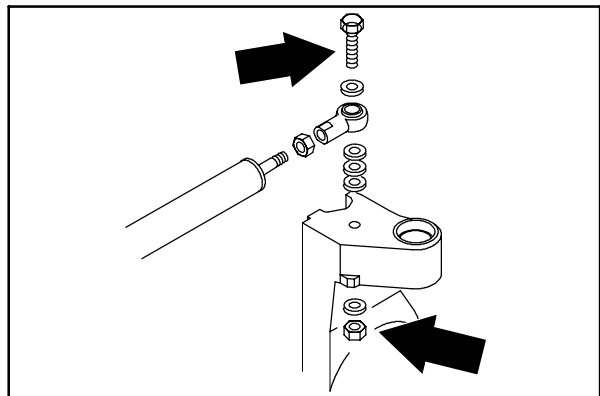
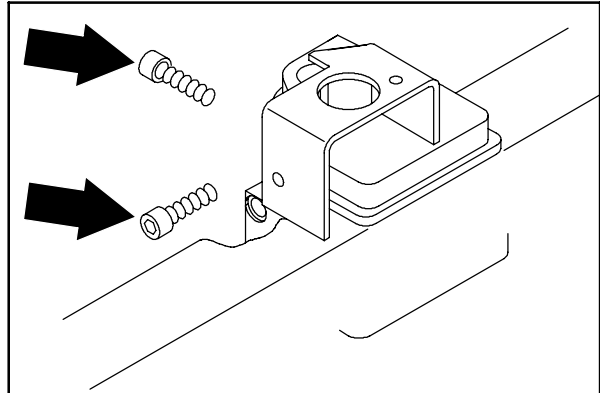
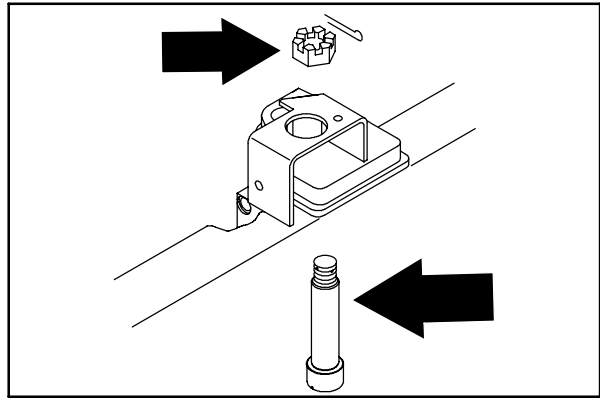

CONTENTS

| | Page | | Page |
|-----------------------------|------|-----------------------------|------|
| INTRODUCTION | 3-3 | HOPPER DOOR SEALS | 3-31 |
| DEBRIS HOPPER | 3-4 | TO REPLACE HOPPER DOOR | |
| TO REMOVE HOPPER | 3-4 | SEALS | 3-32 |
| TO INSTALL HOPPER | 3-5 | HOPPER COVER SEAL | 3-33 |
| TO ADJUST HOPPER | 3-6 | TO REPLACE HOPPER | |
| TO ADJUST HOPPER BUMPER .. | 3-7 | COVER SEAL | 3-33 |
| HOPPER DUMP DOOR | 3-8 | HOPPER DUST SEAL | 3-34 |
| TO REMOVE HOPPER DUMP | | TO REPLACE HOPPER | |
| DOOR | 3-8 | DUST SEAL | 3-34 |
| TO INSTALL HOPPER DUMP | | HOPPER VACUUM FAN SEAL ... | 3-35 |
| DOOR | 3-9 | TO REPLACE HOPPER VACUUM | |
| TO ADJUST HOPPER DUMP | | FAN SEAL | 3-35 |
| DOOR | 3-10 | HOPPER LIFT ARMS | 3-36 |
| HOPPER DUST FILTER | 3-11 | TO REMOVE HOPPER LIFT | |
| TO REMOVE OR REPLACE HOPPER | | ARMS | 3-36 |
| DUST FILTER | 3-12 | TO INSTALL HOPPER LIFT | |
| THERMO SENTRY™ | 3-14 | ARMS | 3-37 |
| TO REPLACE THERMO SENTRY™ | 3-14 | SWEEPING VACUUM FAN | 3-38 |
| BRUSHES . | 3-15 | TO REMOVE SWEEPING | |
| MAIN SWEEP BRUSH | 3-15 | VACUUM FAN | 3-38 |
| REPLACING MAIN SWEEP | | TO INSTALL SWEEPING | |
| BRUSH | 3-16 | VACUUM FAN | 3-39 |
| CHECKING AND ADJUSTING | | TO REPLACE SWEEPING | |
| MAIN SWEEP BRUSH | | VACUUM FAN IMPELLER | 3-40 |
| PATTERN | 3-17 | MACHINE TROUBLESHOOTING ... | 3-41 |
| TO REPLACE MAIN BRUSH | | | |
| IDLER PLUG BEARING ... | 3-19 | | |
| TO REPLACE BRUSH SHAFT | | | |
| BEARINGS | 3-20 | | |
| SIDE BRUSH | 3-22 | | |
| REPLACING SIDE BRUSH ... | 3-23 | | |
| SIDE BRUSH GUARD | 3-24 | | |
| TO ROTATE OR REPLACE SIDE | | | |
| BRUSH GUARD | 3-24 | | |
| SKIRTS AND SEALS | 3-25 | | |
| HOPPER LIP SKIRTS | 3-25 | | |
| TO REPLACE HOPPER LIP | | | |
| SKIRTS | 3-25 | | |
| BRUSH DOOR SKIRTS | 3-26 | | |
| TO REPLACE AND ADJUST | | | |
| BRUSH DOOR SKIRTS ... | 3-26 | | |
| REAR SKIRT AND DEFLECTOR | | | |
| BLADE | 3-27 | | |
| TO REPLACE AND ADJUST | | | |
| THE REAR SKIRT AND | | | |
| DEFLECTOR BLADE ... | 3-28 | | |
| BRUSH DOOR SEALS | 3-29 | | |
| HOPPER SEALS | 3-29 | | |
| TO REPLACE HOPPER | | | |
| SEALS | 3-29 | | |
| HOPPER INSPECTION DOOR | | | |
| SEAL | 3-31 | | |

INTRODUCTION

The side brush sweeps debris into the path of the main brush. The main brush sweeps debris from the floor into the hopper. The vacuum system pulls dust and air through the hopper and the hopper dust filter.

SWEEPING

DEBRIS HOPPER

The debris hopper collects the debris swept up by the machine. The hopper includes the following main components: hopper dust filters, hopper dump door, and dust skirts. All adjustments have been made at the factory and require no regular maintenance. If the hopper components are repaired or replaced, some components may need to be readjusted for best performance. The hopper may need to be removed from the machine some repair or service work.

TO REMOVE HOPPER

FOR SAFETY: Before Leaving Or Servicing Machine; Stop On Level Surface, Set Parking Brake, Turn Off Machine And Remove Key.

1. Engage the parking brake.
2. Start the engine and raise the hopper high enough to position two 4" tall blocks on the floor under the hopper. Lower the hopper down on these blocks. Shut off the engine.
3. Open the hopper cover, unplug the wires from the filter shaker and Thermo Sentry™.
4. Remove the filter carrier tray from the machine.
5. Remove the six M12 hex screws and nyloc nuts holding the lift arms to hopper sides.
6. Start the machine and carefully back it away from the hopper a few feet. Watch the right hand lift arm when backing up, it needs to clear the hopper solenoid valve on the way out.
7. After the machine is clear of the hopper, shut off engine and disconnect and plug hydraulic hoses leading from hopper to the machine.

NOTE: Observe hydraulic cleanliness requirements when opening hydraulic lines.

8. Disconnect the hopper wire harness from the main harness. Unplug the vacuum fan solenoid from the main harness.
9. The hopper can now be removed from the machine.

NOTE: Do not start engine with hydraulic hoses disconnected.

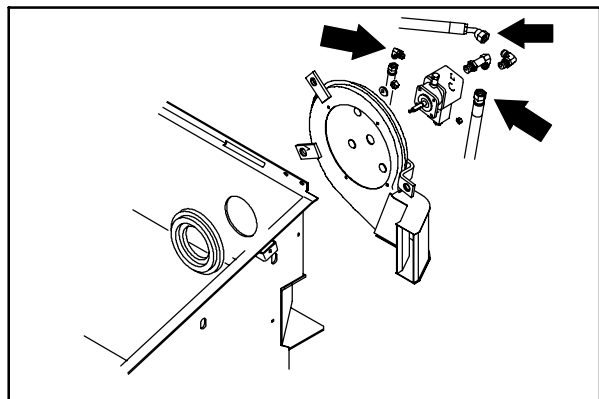
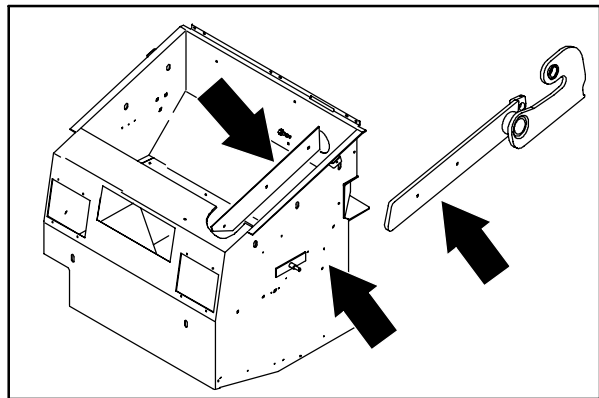
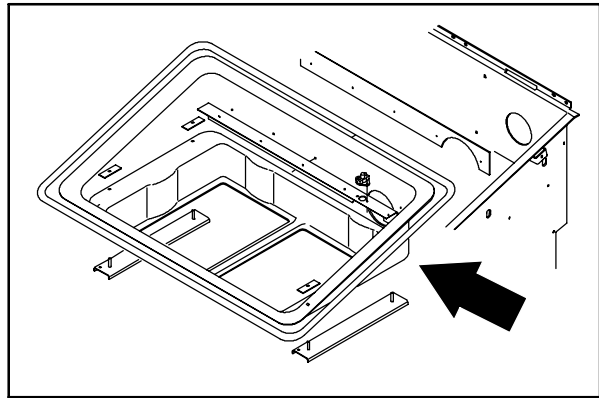
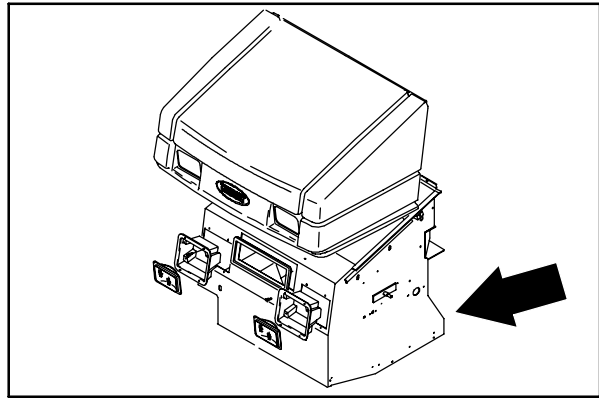

TO INSTALL HOPPER

FOR SAFETY: Before Leaving Or Servicing Machine; Stop On Level Surface, Set Parking Brake, Turn Off Machine And Remove Key.

1. Position the hopper in front of the machine. Move the hopper in close enough to reconnect the hydraulic hoses and the wire harness.

NOTE: Make sure the hopper cover is in the raised position.

2. See the schematic in the HYDRAULICS section of this manual for proper hose connections.
3. See the schematic in the ELECTRICAL section of this manual for proper harness connections.
4. The machine can now be started and carefully inched forward. The right hand lift arm must clear the hopper solenoid valve when positioning hopper back in the machine.

NOTE: Be careful not to pinch hydraulic hoses or electrical wires during this procedure.

5. The hopper must go in until the rubber pads on the bumper hit the machine frame.
6. Remove the filter tray from the hopper.
7. Align the holes in lift arms with the holes in hopper sides. It may be necessary to use a pry bar for the final alignment.

NOTE: Hopper must be on 4" tall blocks for proper adjustment before installing hardware.

8. Install six M12 hex screws, nyloc nuts and Belleville washers along with the two hopper plates. Tighten to 90 - 117 Nm (65 - 85 ft lb).
9. Install the hydraulic hose clamps to the hopper lift arm.
10. Reinstall the filter tray back in the hopper and reconnect the wires to the filter shaker and Thermo Sentry™.
11. Start the engine and check for proper operation of the hopper vacuum fan, dump door, side brush rotation and side brush up and down.

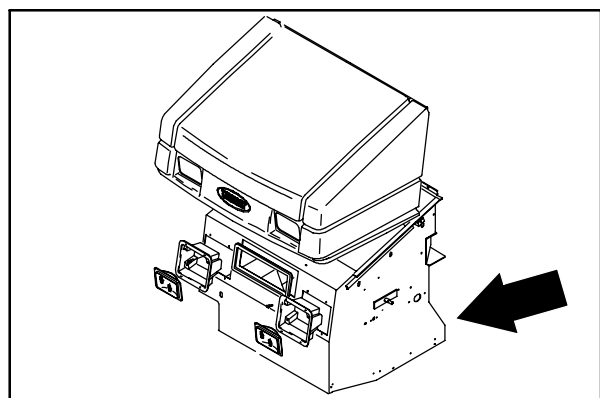
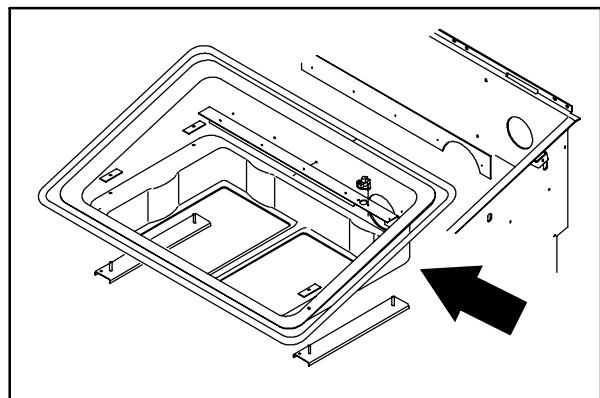
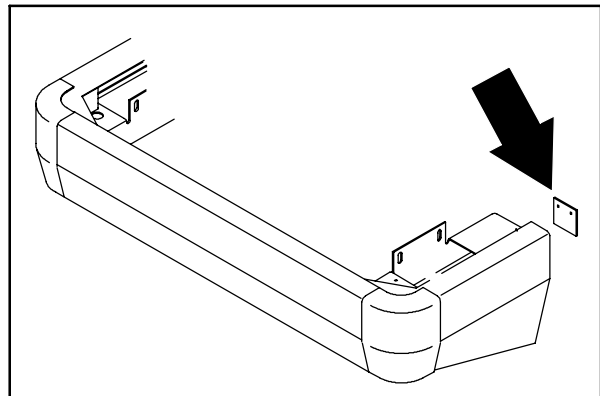
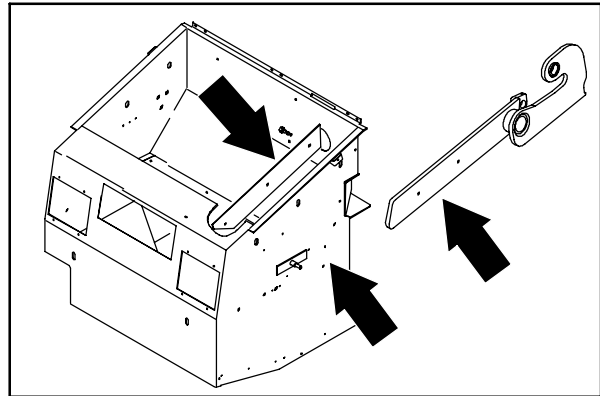

SWEEPING

TO ADJUST HOPPER

FOR SAFETY: Before Leaving Or Servicing Machine; Stop On Level Surface, Set Parking Brake, Turn Off Machine And Remove Key.

1. Engage the parking brake.
2. Start the engine and raise the hopper high enough to position two 4" tall blocks on the floor under the hopper. Lower the hopper down on these blocks. Shut off the engine.
3. Open the hopper cover, unplug the wires from the filter shaker and Thermo Sentry™.
4. Remove the filter carrier tray from the machine.
5. Loosen the six M12 hex screws and nyloc nuts holding lift arms to hopper. Make sure hopper arms drop down to the lowest position, and the hopper is all the way back against the main frame.
6. Tighten the six M12 hex screws and nyloc nuts to Tighten to 90 - 117 Nm (65 - 85 ft lb).
7. Reinstall the filter tray back in the hopper and reconnect the wires to the filter shaker and Thermo Sentry™.
8. Start the engine, raise the hopper high enough to remove the two 4" tall blocks. Lower the hopper and check for proper hopper to floor clearance.

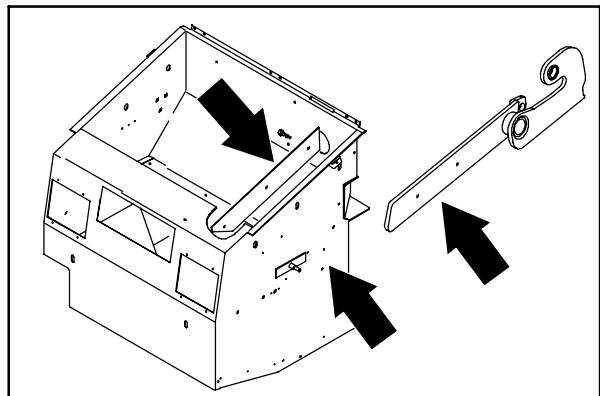
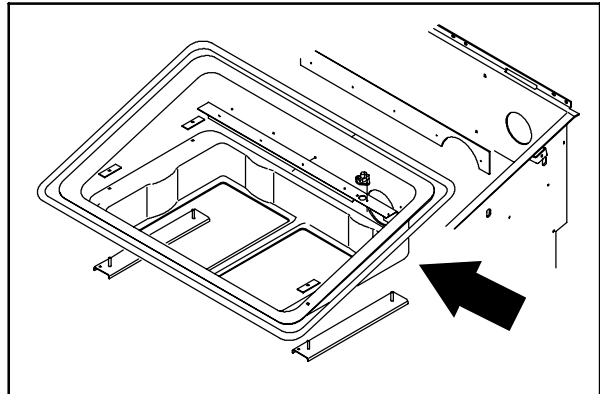
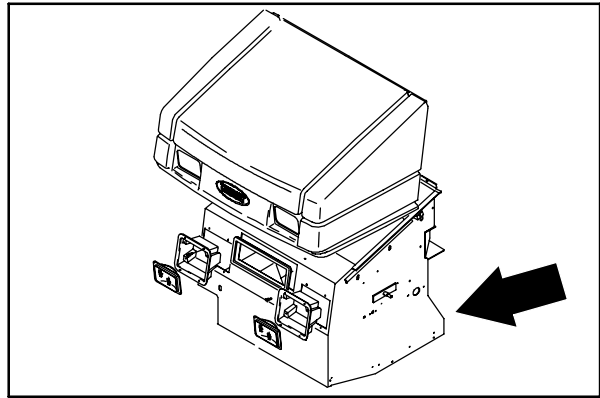

TO ADJUST HOPPER BUMPER

FOR SAFETY: Before Leaving Or Servicing Machine; Stop On Level Surface, Set Parking Brake, Turn Off Machine And Remove Key.

1. Using a long straight edge, check the levelness of the hopper bumper to the machine frame. If there is more than an 1/8 in. difference; the bumper needs to be adjusted.
2. Use a hoist or a floor jack to hold up the bumper while loosening the six M10 hex screws holding it to the hopper.
3. Using the straight edge and hoist, re-align the bumper to the frame. Tighten the M10 hex screws to 52 - 67 Nm (39 - 51 ft lb).
4. Remove the hoist, shut the hopper cover, check the hood and bumper for proper alignment.

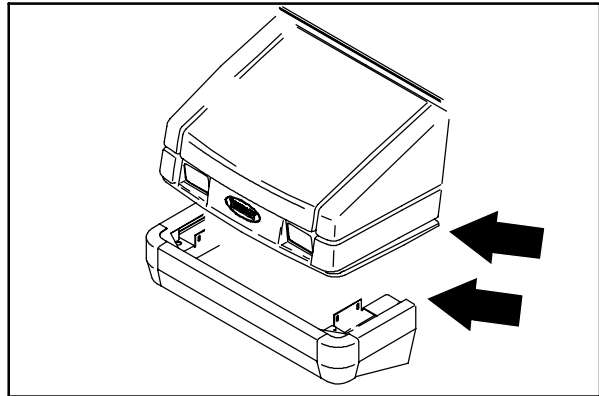
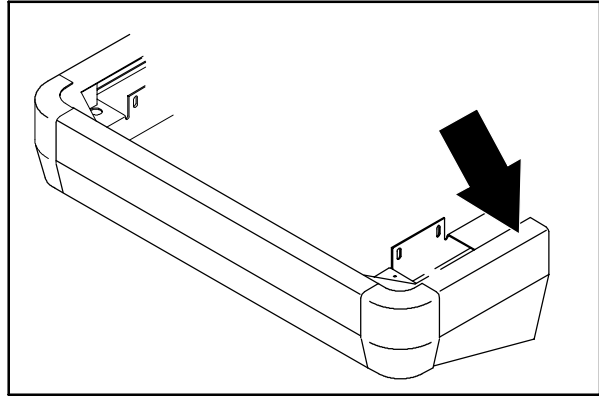

SWEEPING

HOPPER DUMP DOOR

The hopper dump door is used to control the debris when dumping.

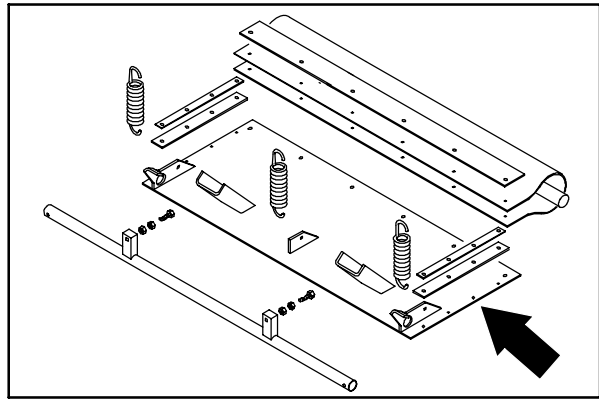

TO REMOVE HOPPER DUMP DOOR

FOR SAFETY: Before Leaving Or Servicing Machine; Stop On Level Surface, Set Parking Brake, Turn Off Machine And Remove Key.

1. Make sure the hopper is emptied of all debris. Engage the parking brake.
2. Open the dump door and hopper cover.
3. Remove the clevis pin holding the rod end of dump door cylinder and dust door pivot link to the dump door pivot yoke.
4. Using a hammer and punch; drive the roll pins out of the pivot yokes. Remove the pivot yokes from the machine.
5. Remove the four M8 hex screws and flange nuts holding the bearing pivot hubs to the hopper. Remove both hubs.
6. Close the hopper cover.
7. Raise the hopper and engage the safety arm.

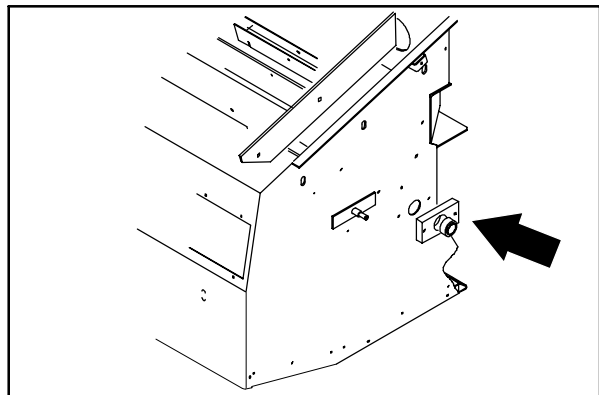
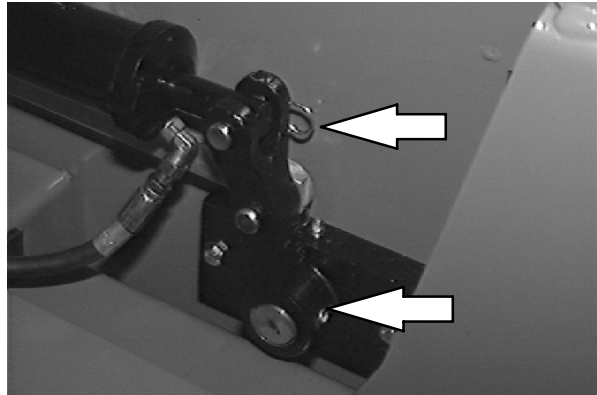

⚠ WARNING: Raised Hopper May Fall. Engage Hopper Support Bar.

8. Completely loosen the two adjustment bolts on the dump door pivot rod.
9. Using a vice grip and a pry bar, remove the three springs from the dump door.
10. Slide the dump door all the way in either direction, drop one side down, remove the dump door from the machine.

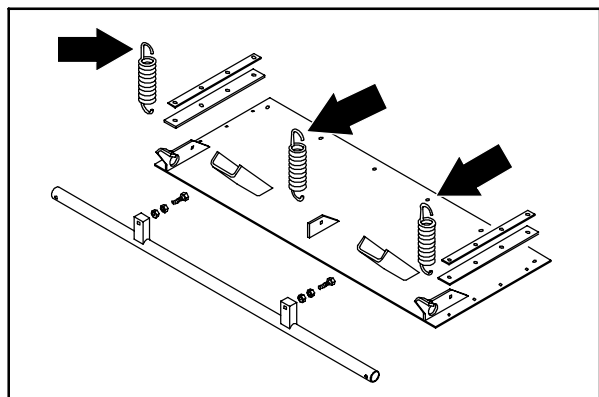

TO INSTALL HOPPER DUMP DOOR

FOR SAFETY: Before Leaving Or Servicing Machine; Stop On Level Surface, Set Parking Brake, Turn Off Machine And Remove Key.

1. Make sure the hopper is emptied of all debris. Engage the parking brake.
2. Raise the hopper and engage safety arm.
3. Slide the pivot rod weldment in the holes on hopper dump door.

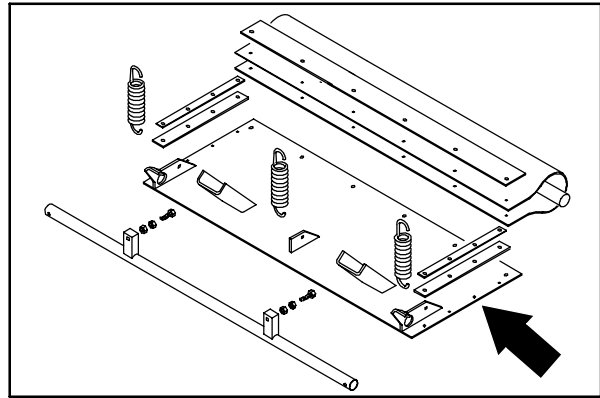

NOTE: Both of the bearing pivot blocks must be removed before the next step can be completed.

4. Place one end of dump door assembly in one of the holes in rear of hopper. Slide it all the way to one side, bring up the other end and place it in the other hole. Center the door in machine.
5. Reconnect the three tension springs from eye bolts in hopper to holes in brackets on dump door. Use a vice grips and a pry bar to hook the springs in the holes.
6. Set the adjustment bolts on the dump door to 3/4 in. from the head of the bolt to edge of the bracket.
7. Disengage the safety arm, lower the hopper and open hopper cover.
8. Reinstall both bearing pivot blocks using four M8 hex head screws and flange nuts. Tighten to 18 - 24 Nm (13 - 18 ft lb).
9. Install pivot yokes on the dump door rod with the smooth side towards the hopper.

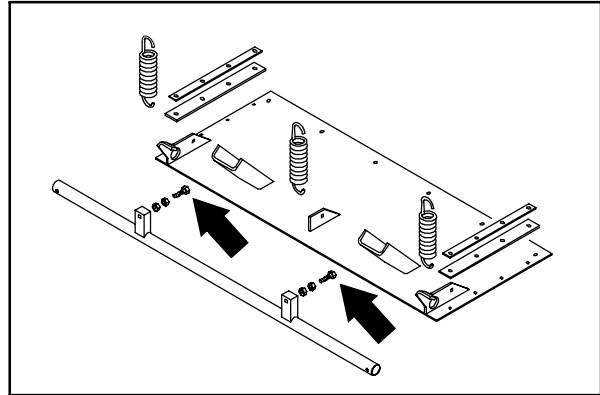

10. Align the holes in the rod with holes in the pivot yoke. Use a hammer to drive the roll pins in flush.
11. Reconnect the rod end of dump door cylinder and the dust door pivot link to dump door pivot yoke using the clevis pins and hair pins.
12. Start the machine and open and close the hopper door a few times checking for proper operation.

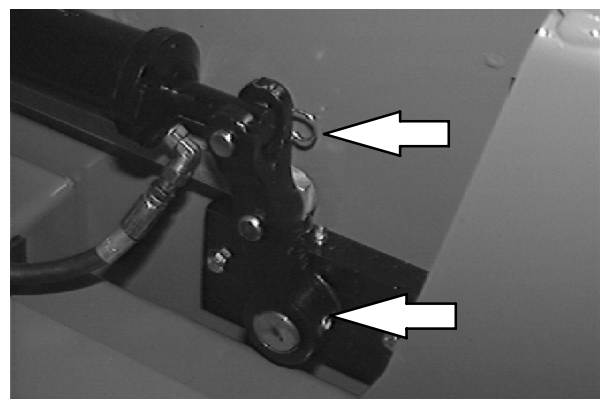
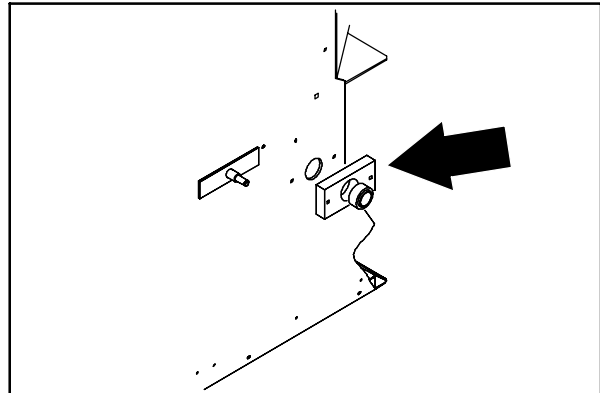

SWEEPING

TO ADJUST HOPPER DUMP DOOR

FOR SAFETY: Before Leaving Or Servicing Machine; Stop On Level Surface, Set Parking Brake, Turn Off Machine And Remove Key.

1. Make sure the hopper is emptied of all debris. Engage the parking brake.
2. Open the dump door.
3. Raise the hopper and engage the safety arm.
4. Measure the opening between the inside of the dump door to the inside lower corner of the hopper. This dimension should be 10.5".
5. Use the two adjustment screws on the dump door to achieve this dimension.

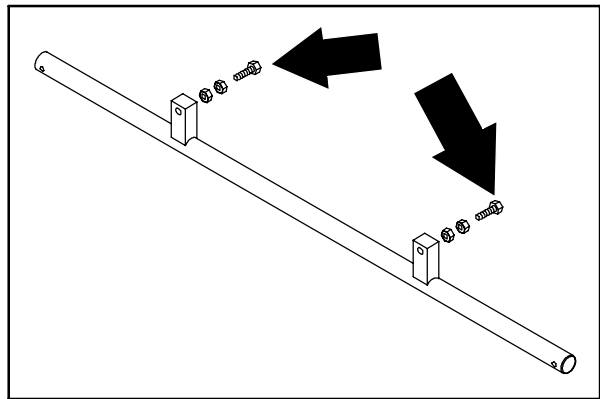
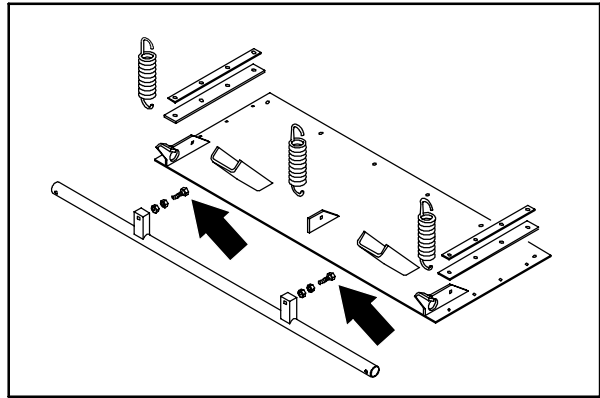

HOPPER DUST FILTER

The dust filters filter the air pulled up from the hopper. The dust filters are equipped with a shaker to remove the accumulated dust particles. The dust filters shaker is operated by the filter shaker switch.

Shake the dust filters before dumping the hopper and at the end of every work shift. Check and clean the dust filters every 50 hours of operation. Extremely dusty conditions may require more frequent cleaning of dust filters.

To clean the dust filters, use one of the following methods:

- **SHAKING** - Press the filter shaker switch.
- **TAPPING** - Tap the filter gently on a flat surface with the dirty side down. Do not damage the edges of the filter element or the filter will not seat properly in the filter frame.
- **AIR** - Always wear eye protection when using compressed air. Blow air through the dust filter opposite the direction of the arrows. Never use more than 690 kPa (100 psi) of air pressure and never closer than 50 mm (2 in) away from the filter.

FOR SAFETY: When Servicing Machine, Wear Eye And Ear Protection When Using Pressurized Air Or Water.

- **WATER** - The dust filter can be rinsed with water, but the filter will degrade with each rinsing. Replaced the filter after rinsing five times. Rinse with a low pressure garden hose through the dust filter opposite the direction of the arrows.

NOTE: Be sure the dust filter is dry before reinstalling it in the machine.

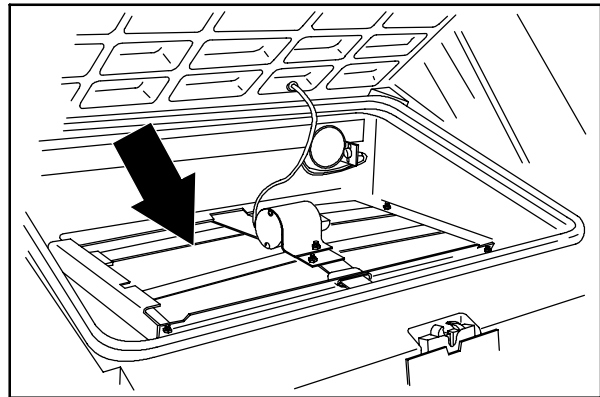

SWEEPING

TO REMOVE OR REPLACE HOPPER DUST FILTER

1. Stop the engine and set the machine parking brake.

FOR SAFETY: Before Leaving Or Servicing Machine; Stop On Level Surface, Set Parking Brake, Turn Off Machine And Remove Key.

2. Open the hopper cover.
3. Disconnect the shaker motor wire connectors.
4. Remove the four retaining screws from the filter shaker frame.
5. Pull the filter shaker frame out of the hopper.

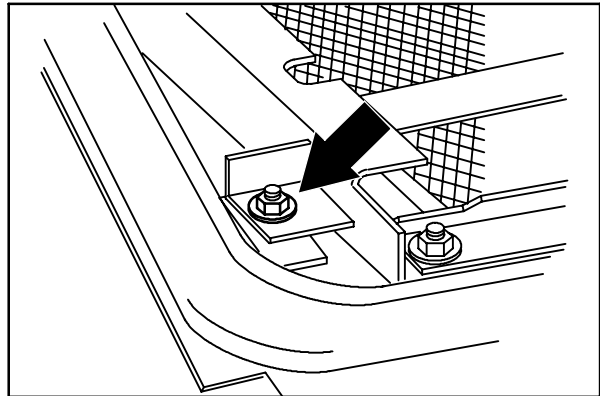
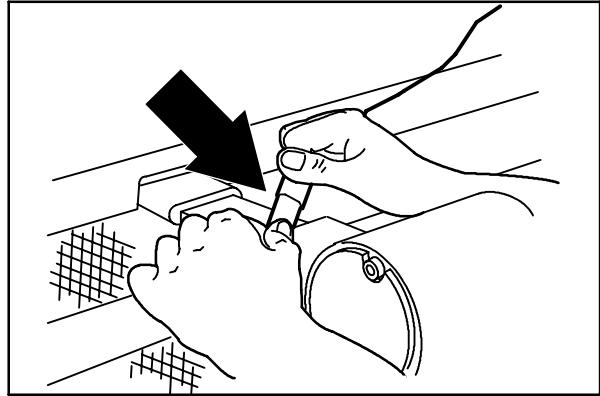

6. Lift the dust filter element out of the hopper insert.

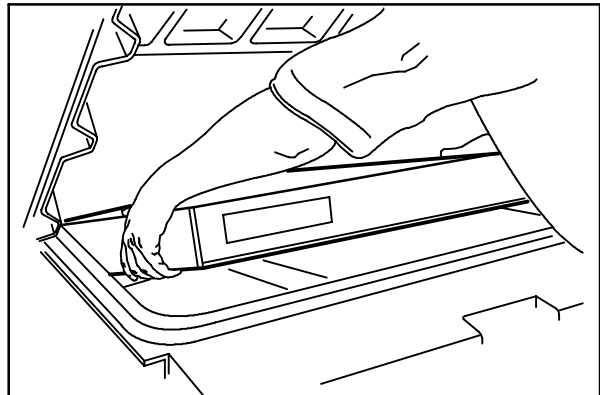

7. Clean or discard the dust filter as required.
8. Put the cleaned or new dust filter in the hopper insert with the arrows pointing up.

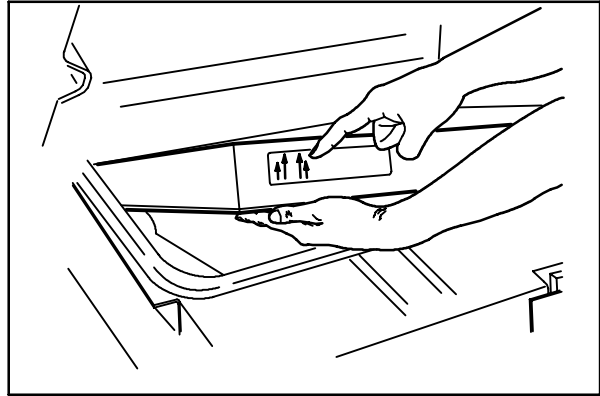

9. Install the four retaining screws and tighten.
10. Connect the shaker motor wire connectors.

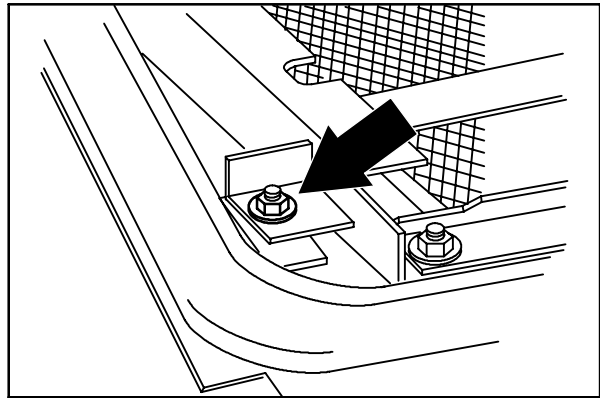

SWEEPING

THERMO SENTRY™

The Thermo Sentry™ senses the temperature of the air pulled up from the hopper. If there is a fire in the hopper, the Thermo Sentry™ stops the vacuum fan and cuts off the air flow.

Reset the Thermo Sentry™ by pushing in its reset button.

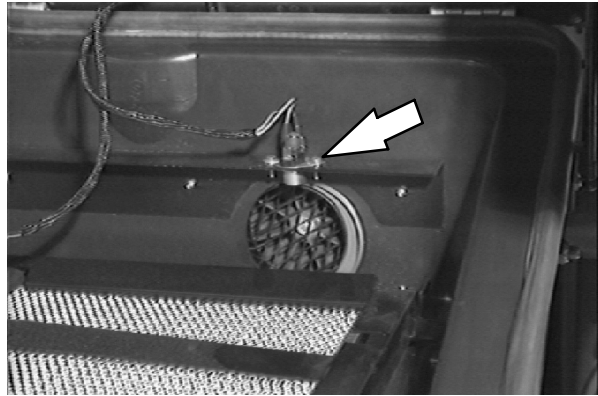

TO REPLACE THERMO SENTRY™

1. Open the hopper cover.
2. Disconnect the Thermo Sentry™ from the hopper harness.
3. Remove the two screws holding the Thermo Sentry™ to the stiffener plate. Remove the Thermo Sentry™.
4. Mount the new Thermo Sentry™ to the stiffener plate with existing hardware.
5. Connect the new Thermo Sentry™ to the hopper wire harness.
6. Close the hopper cover.

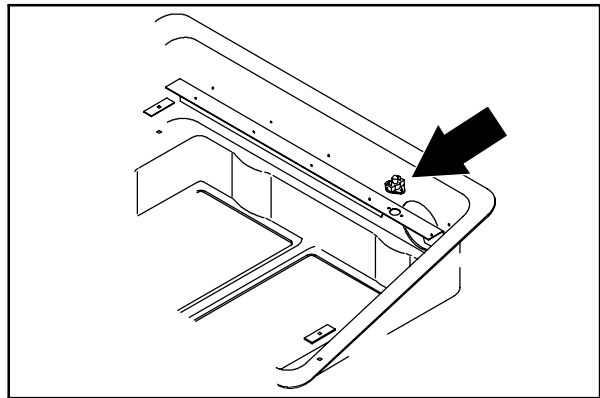

BRUSHES

MAIN SWEEP BRUSH

The main sweep brush is cylindrical and spans the width of the machine, sweeping debris into the hopper.

Check the brush daily for wear or damage. Remove any string or wire tangled on the main brush, main brush drive hub, or main brush idler hub.

Check the main sweep brush pattern daily. The pattern should be 50 to 65 mm (2.0 to 2.5 in) wide with the main sweep brush in the lowered position. Adjust the main sweep brush pattern by turning the main brush pressure knob located next to the brush position lever.

Rotate the main brush end-for-end every 50 hours of operation for maximum brush life and best sweeping performance.

Replace the main sweep brush when the remaining bristles measure 25 mm (1 in) in length.

SWEEPING

REPLACING MAIN SWEEP BRUSH

1. Stop the engine and set the machine parking brake.

FOR SAFETY: Before leaving or servicing machine; stop on level surface, set parking brake, turn off machine and remove key.

2. Raise the main sweep brush.
3. Open the right side brush access door.
4. Unlatch and remove the brush idler plate.

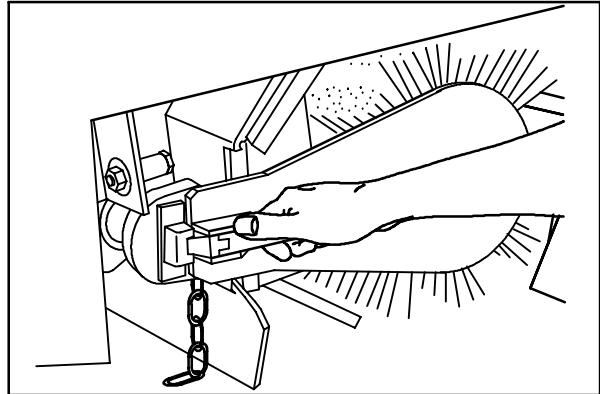

08016

5. Grasp the main sweep brush; pull it off the brush drive plug and out of the main brush compartment.
6. Put the new or rotated end-for-end main sweep brush on the floor next to the access door.

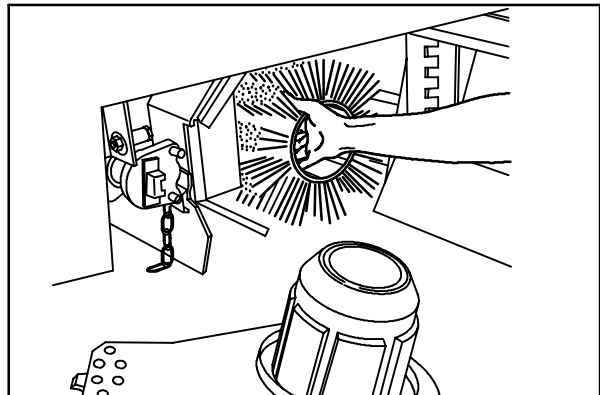

08017

7. Slide the main sweep brush onto the drive plug. Rotate the brush until it engages the drive plug, and push it all the way onto the plug.
8. Slide the brush idler plate plug onto the main sweep brush.
9. Latch the idler plate onto the machine frame.
10. Close the right side brush access door.

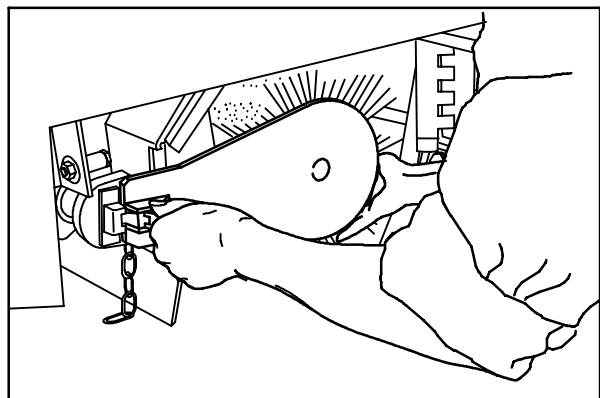

08018

CHECKING AND ADJUSTING MAIN SWEEP BRUSH PATTERN

1. Apply chalk, or some other material that will not blow away easily, to a smooth, level floor.
2. Raise the side brush and main sweep brush and position the main sweep brush over the chalked area.
3. Start the main sweep brush.
4. Lower the main sweep brush for 15 to 20 seconds while keeping a foot on the brakes to keep the machine from moving. This will lower the rotating main sweep brush.

NOTE: If chalk or other material is not available, allow the sweep brush to spin on the floor for two minutes. A polish mark will remain on the floor.

5. Raise the main sweep brush.
6. Stop the main sweep brush.
7. Drive the machine off the test area.
8. Observe the width of the brush pattern. The proper brush pattern width is 50 to 65 mm (2.0 to 2.5 in).

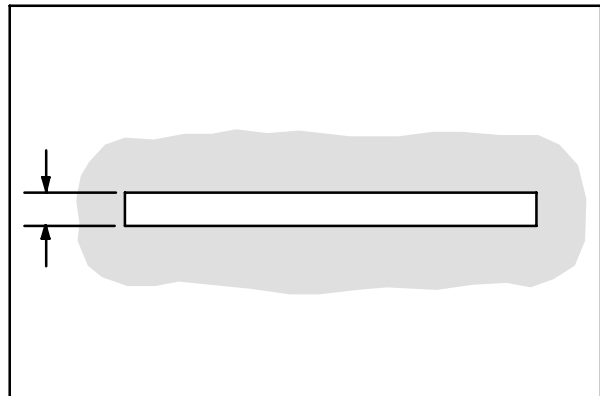

00582

9. To increase the width of the main sweep brush pattern, turn the main sweep brush down pressure knob counter-clockwise.

To decrease the width of the main sweep brush pattern, turn the main sweep brush down pressure knob clockwise.

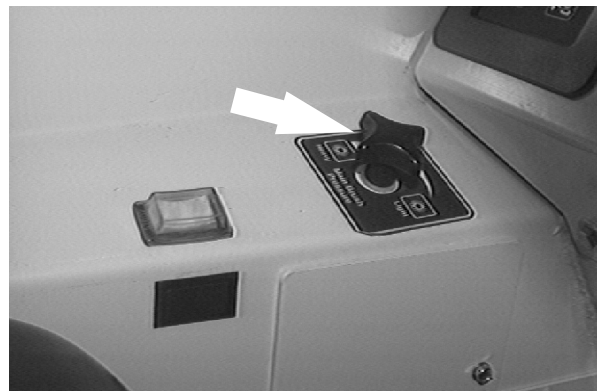

SWEEPING

If the main sweep brush pattern is tapered, more than 15 mm (0.5 in) on one end than the other, adjust the taper with the taper adjustment bracket at the idler end of the brush.

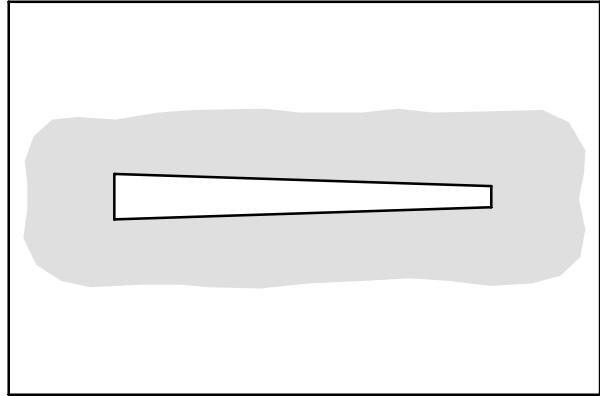

00601

- A. Loosen the bracket mounting bolts.

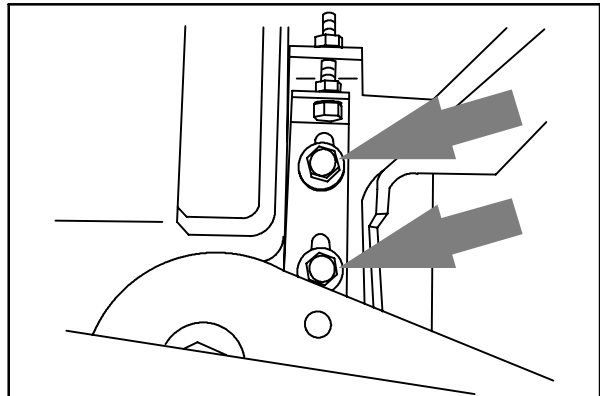

09183

- B. Turn the taper adjustment nut counter-clockwise to increase the pattern width at the brush idler end, and clockwise to decrease the pattern width at the brush idler end. Tighten the mounting bolts.
- C. Check the main sweep brush pattern and readjust as necessary. Then adjust the width of the main brush pattern.

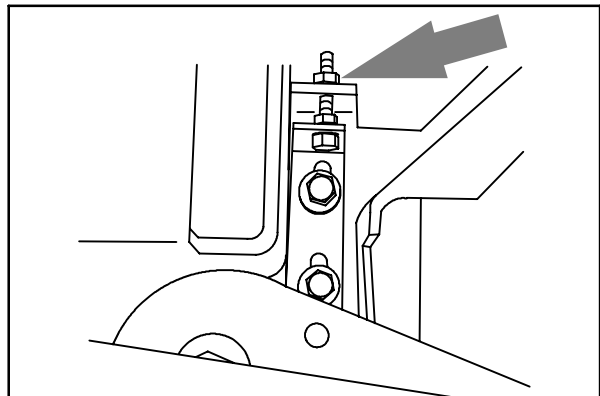

09184

TO REPLACE MAIN BRUSH IDLER PLUG BEARING

FOR SAFETY: Before Leaving Or Servicing Machine; Stop On Level Surface, Set Parking Brake, Turn Off Machine And Remove Key.

1. Open the right side brush door and remove the main brush idler arm from machine.
2. Remove the plastic cap from the idler plug.
3. Remove the M12 hex screw, nyloc hex nut, and washer holding the idler plug to the brush idler arm. Save the hardware.
4. Remove the four M6 hex screws holding the idler shaft in the idler plug. Remove the shaft. Save the hardware.
5. Remove the bearing seal plate, retainer and bearing.
6. Clean the inside of the idler plug.
7. Place a new bearing, the seal plate and the retainer in the idler.
8. Reinstall the four screws and flat washers.
9. Install the idler shaft and tighten the four M6 hex screws to 8–10 Nm (6–8 ft lb).
10. Position the idler plug and shaft on the brush idler arm. Reinstall the hardware removed earlier. Tighten to 68–81 Nm (50–60 ft lb).
11. Apply RTV to the area where plastic cap will fit in the end of idler plug. Snap plastic cap into place.

NOTE: If you replace idler arm latch, use blue loctite on hardware to hold in place.

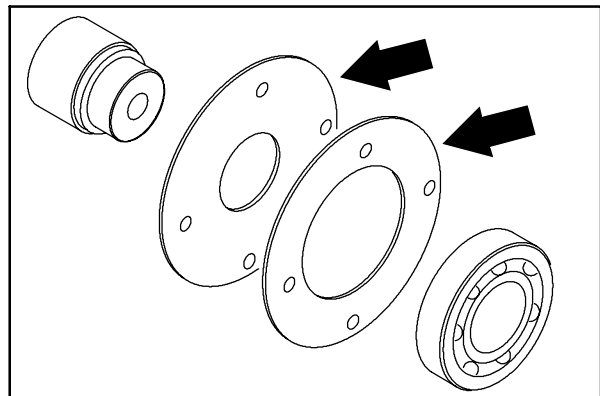
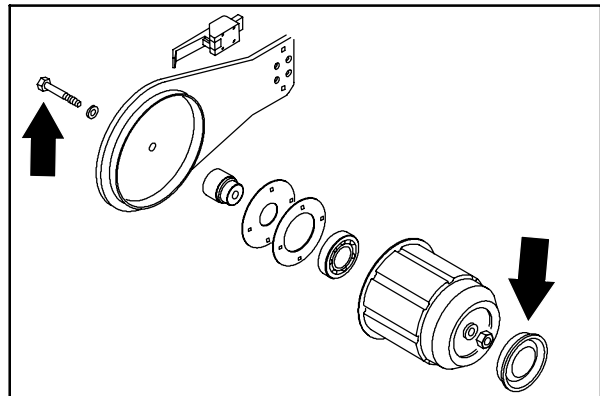
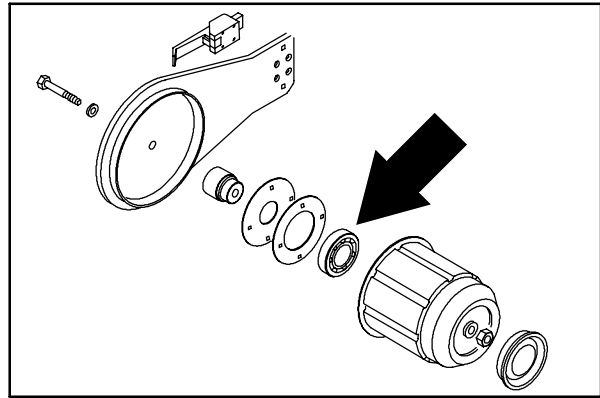

SWEEPING

TO REPLACE BRUSH SHAFT BEARINGS

FOR SAFETY: Before Leaving Or Servicing Machine; Stop On Level Surface, Set Parking Brake, Turn Off Machine And Remove Key.

1. Remove the main brush and idler.
2. Remove the main brush motor mount plate from the brush shaft.

NOTE: The hydraulic hoses can be left hooked up to the motor when removing the mount plate.

3. Remove the brush lift cable clevis from the brush shaft arm.
4. Loosen the main brush taper adjustment screw.
5. Remove the hardware holding each of the two brush shaft flange bearings.
6. Pull the brush shaft out of the machine.
7. Use a punch and a hammer to drive the brush hub roll pins out of the brush hubs.
8. Slide the brush hubs off the end of the shaft.
9. Remove the remaining hardware holding the bearing collars in place.
10. Loosen the bearing set screws and slide the bearings off the shaft.
11. Slide the new bearings on the shaft with the collar facing the ends of the shaft. Be sure to have a bearing flange on each side of the bearings.
12. Slide the brush hubs on each end of the brush shaft.
13. Align the hole in the hub with the hole in the shaft.

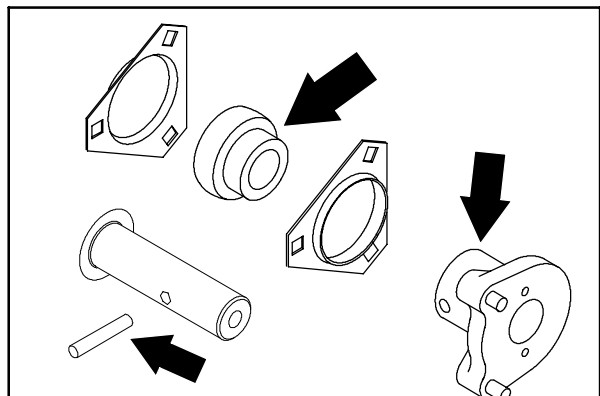
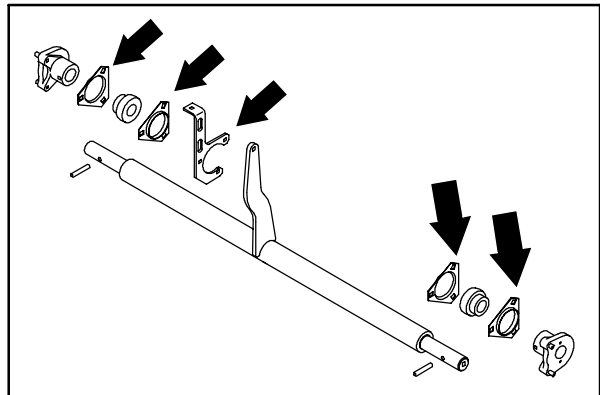
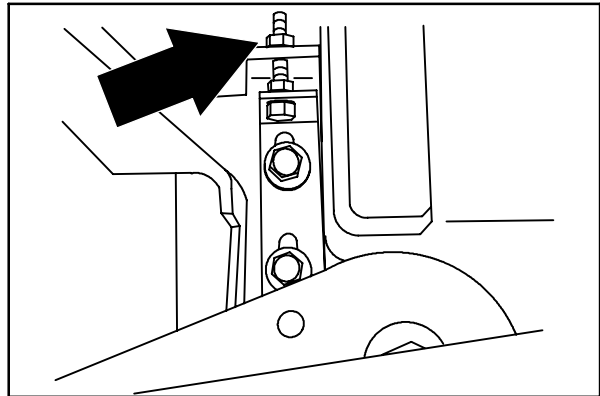
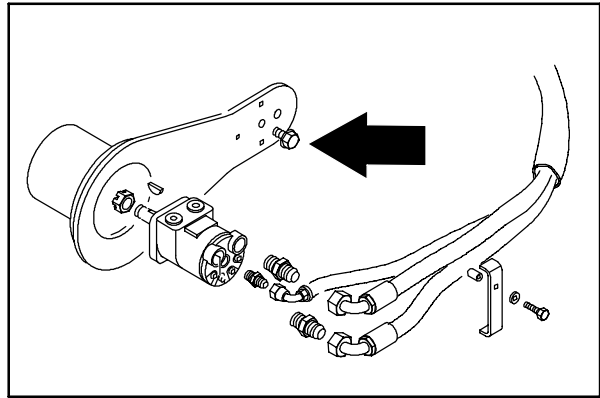

14. Use a hammer to pound the roll pin in flush.
15. Mount the main brush shaft plate to the right side bearing flange. Tighten the hardware to 22-27 Nm (16-20 ft lb).

NOTE: If you are replacing the idler arm latch bracket, use blue loctite to hold the bolts in place. Tighten the bolts to 8-10 Nm(6-8 ft lb).

16. Center the brush shaft in the machine. Tighten the bearing collar set screws.
17. Connect the main brush lift cable to the brush shaft arm with the clevis pin removed earlier.
18. Reinstall the main brush hydraulic motor mount plate. Tighten the hex screw to 64 - 83 Nm (47 - 61 ft lb).
19. Reinstall the main brush and idler.
20. Check the main brush pattern for taper and width.

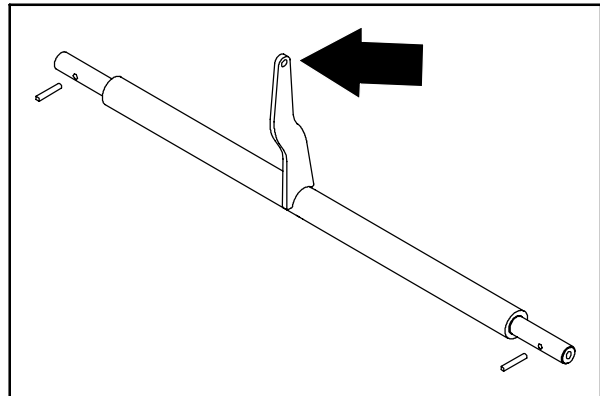
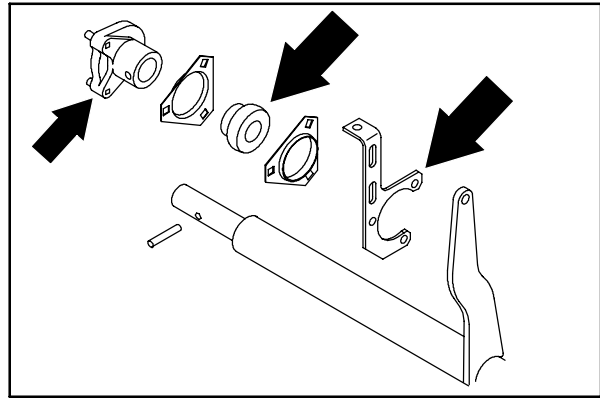

SWEEPING

SIDE BRUSH

The side brush sweeps debris along edges into the path of the main brush.

Check the brush daily for wear or damage. Remove any string or wire found tangled on the side brush or side brush drive hub.

Check the side brush pattern daily. The side brush bristles should contact the floor in a 10 o'clock to 3 o'clock pattern when the brush is in motion.

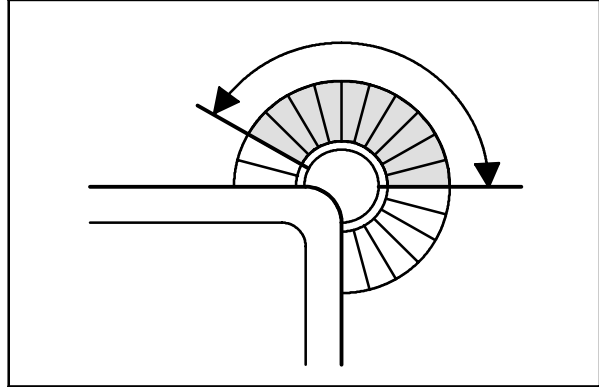

350327

Adjust the side brush pattern by the side brush down pressure knob. Turn the knob counter-clockwise to increase the brush contact with the sweeping surface, and clockwise to decrease the brush contact with the sweeping surface.

The side brush should be replaced when it no longer sweeps effectively for your application. A guideline length is when the remaining bristles measure 50 mm (2 in) in length. You may change the side brush sooner if you are sweeping light litter, or wear the bristles shorter if you are sweeping heavy debris.



REPLACING SIDE BRUSH

1. Empty the debris hopper.
2. Set the machine parking brake.
3. Stop the engine.

FOR SAFETY: Before leaving or servicing machine; stop on level surface, set parking brake, turn off machine and remove key.

4. Remove the side brush retaining pin from the side brush drive shaft by pulling the pin keeper off over the end of the pin.
5. Slide the side brush off the side brush drive shaft.

NOTE: Remove the drive hub and put it on the new brush if one is not installed.

6. Slide the new side brush onto the side brush drive shaft.
7. Insert the side brush retaining pin through the side brush hub and shaft.
8. Secure the pin by clipping the pin keeper over the end of the pin.
9. Disengage the hopper support bar and lower the hopper.
10. Adjust the side brush pattern with the side brush down pressure knob.

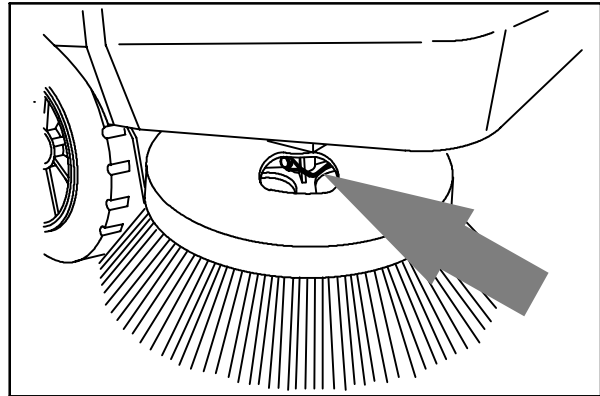

08019

SIDE BRUSH GUARD

The side brush guard protects the side brush from objects along path of the machine. It deflects the side brush out of harms way.

Rotate the side brush guard 90° every 200 hours of operation. Replace the brush guard after all four sides have been used.

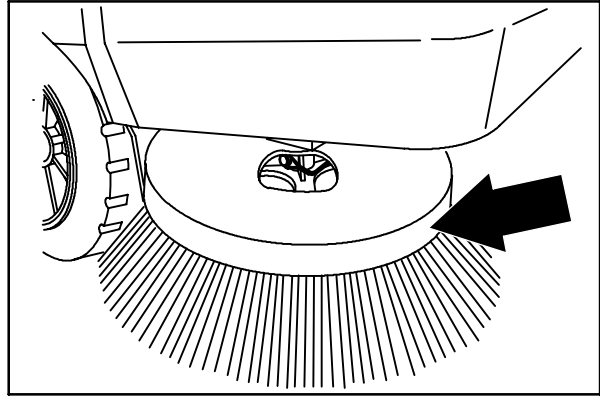

TO ROTATE OR REPLACE SIDE BRUSH GUARD

FOR SAFETY: Before Leaving Or Servicing Machine; Stop On Level Surface, Set Parking Brake, Turn Off Machine And Remove Key.

1. Remove the side brush.
2. Remove the four bolts holding the side brush guard to the side brush motor. Use care not to disturb the motor position.
3. Rotate or replace the side brush guard.
4. Reinstall the four .375 in. hex screws in the side brush motor. Tighten to 22-27 Nm (16-20 ft lb).
5. Install the side brush.

SKIRTS AND SEALS

HOPPER LIP SKIRTS

The hopper lip skirts are located on the bottom rear of the hopper. The skirts float over debris and help deflect that debris into the hopper. The hopper lip skirts consist of five bottom lip segments and two additional side lip segments.

Check the hopper lip skirts for wear or damage daily.

Replace the hopper lip skirts when they no longer touch the floor.

TO REPLACE HOPPER LIP SKIRTS

1. Dump the machine debris hopper.
2. Set the machine parking brake.
3. Raise the hopper and engage the hopper support bar.

 **WARNING: Raised Hopper May Fall. Engage Hopper Support Bar.**

4. Shut off the engine.

FOR SAFETY: Before Leaving Or Servicing Machine; Stop On Level Surface, Set Parking Brake, Turn Off Machine And Remove Key.

5. Remove the hopper lip skirt retaining strip mounting hardware.
6. Remove the hopper lip retaining strip, the hopper lip, and the back-up strip.
7. Thread the retaining strip mounting bolts through the retaining strip, the new hopper lip skirt, the back-up strip, and in the hopper.
8. Tighten the mounting bolts to 8-14 Nm (6-10 ft lb).
9. Start the engine.
10. Disengage the hopper support bar and lower the hopper.
11. Check the skirt for proper adjustment. The skirt should be evenly touching the floor.

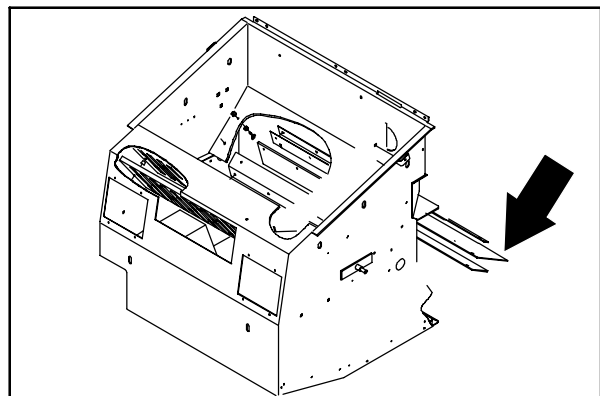
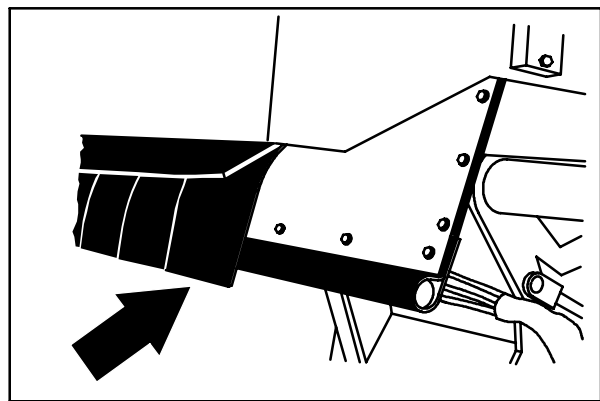
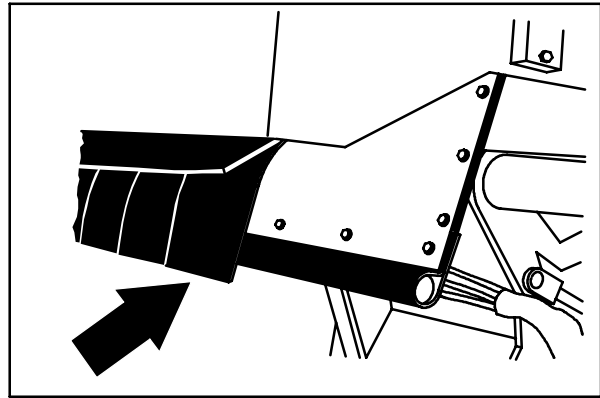

SWEEPING

BRUSH DOOR SKIRTS

The brush door skirts are located on the bottom of each of the two main brush doors. The long skirt should clear the floor by 3 to 6 mm (0.12 to 0.25 in). The inner skirt should be angled so that the rear corner touches the floor, and the front corner is 6 mm (0.25 in) above the corner of the long skirt.

Check the skirts for wear or damage and adjustment daily.

NOTE: The brush door skirts have slotted holes to allow for a ground clearance adjustment. The door must be closed for proper adjustment.

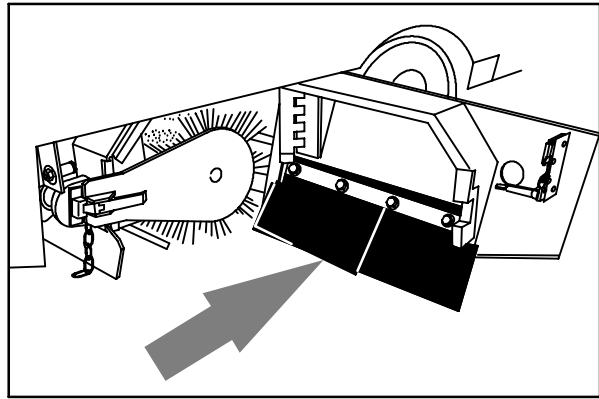

08001

TO REPLACE AND ADJUST BRUSH DOOR SKIRTS

1. Park the machine on a smooth, level surface.
2. Stop the engine and set the machine parking brake.

FOR SAFETY: Before Leaving Or Servicing Machine; Stop On Level Surface, Set Parking Brake, Turn Off Machine And Remove Key.

3. Open the main brush doors.
4. Remove the brush door skirt retaining bolts.
5. Remove the skirt retaining strip and the door skirt.
6. Position the new door skirt and skirt retaining strip on the brush door with the flat edge forward and angled toward the back of the machine.
7. Place the new half-length skirt over the front half of the long skirt. Place the retainer over the skirts.
8. Thread the skirt retaining bolts through the brush door, the door skirts, and into the skirt retaining strip.

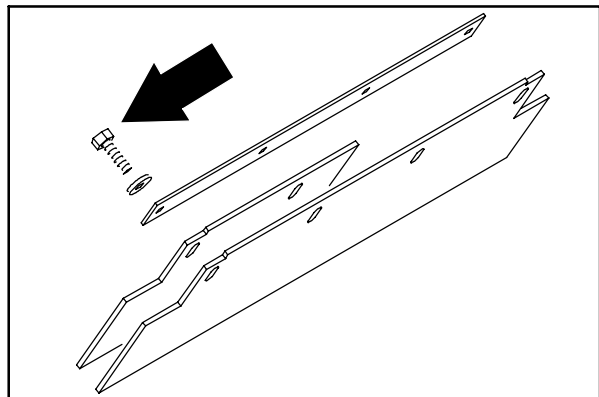
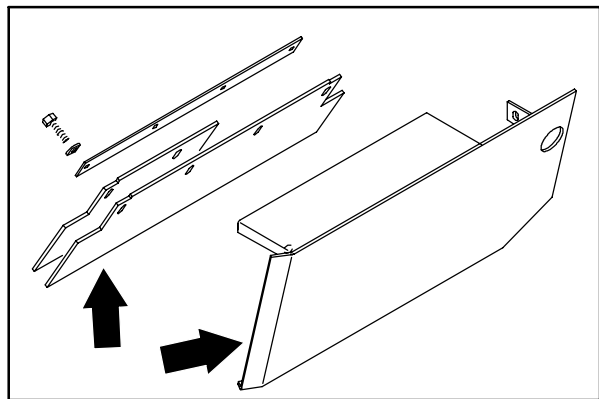

NOTE: The brush door skirts have slotted holes to allow for a ground clearance adjustment. The door must be closed for proper adjustment.

9. Slide the long brush door skirt up or down so it will clear the floor by 3–5 mm (0.12 to 0.25 in). Secure the two bolts holding only one skirt.
10. Adjust the inner half-length skirt so the front edge of it is 5 mm (0.25 in) above the long skirt and the back half just touches the floor. tighten all four bolts to 6–8 ft lb (8–10 Nm).
11. Repeat for the other brush door.

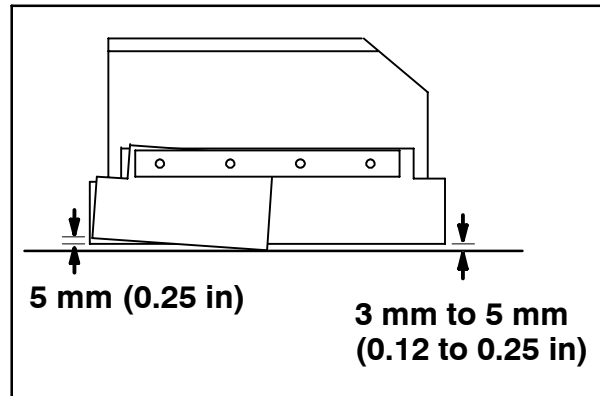

REAR SKIRT AND DEFLECTOR BLADE

The rear skirt and the deflector blade are located on the bottom rear of the main brush compartment. The rear skirt should clear the floor up to 5 mm (0.25 in) in dusty conditions, and touch the floor otherwise. The deflector blade is spring loaded.

Check the skirt and blade for wear or damage and adjustment daily.

NOTE: Rear tire pressure will affect skirt clearances.

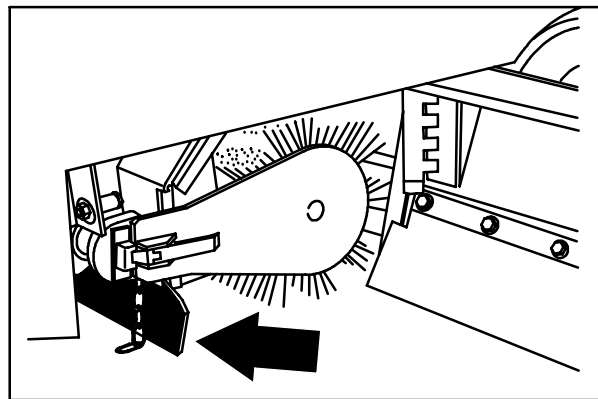

SWEEPING

TO REPLACE AND ADJUST THE REAR SKIRT AND DEFLECTOR BLADE

1. Park the machine on a smooth, level surface.
2. Stop the engine and set the machine parking brake.

FOR SAFETY: Before Leaving Or Servicing Machine; Stop On Level Surface, Set Parking Brake, Turn Off Machine And Remove Key.

3. Open the main brush doors.
4. Remove the main brush.
5. Remove the retaining strip and floor skirt.
6. Thread the mounting bolts through the machine frame, the rear floor skirt, and the retaining strip toward the rear wheel.
7. Slide the rear floor skirt up or down so it clears the floor up to a maximum of 5 mm (0.25 in).
8. Tighten the rear floor skirt mounting bolts to 8–14 Nm (6–10 ft lb).
9. Remove the brush contact blade retaining strip and the brush contact blade.
10. Thread the mounting bolts through the mounting bracket, the brush contact blade, and the retaining strip.
11. Tighten the brush contact blade mounting bolts to 8–14 Nm (6–10 ft lb).
12. Make sure the deflector spring moves the blade into position freely.
13. Reinstall the main brush.
14. Close the main brush doors.

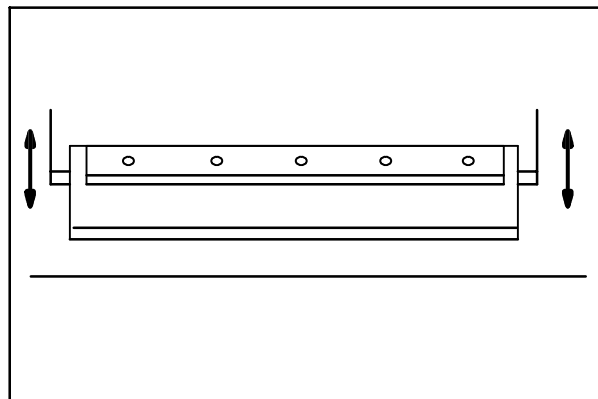
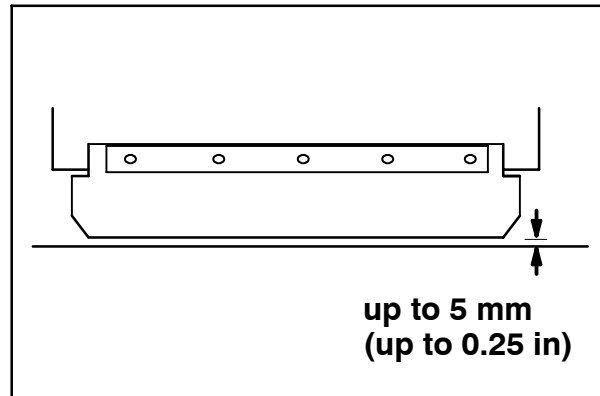

BRUSH DOOR SEALS

The brush door seals are located on both main brush doors and on corresponding portions of the main frame.

Check the seals for wear or damage every 100 hours of operation.

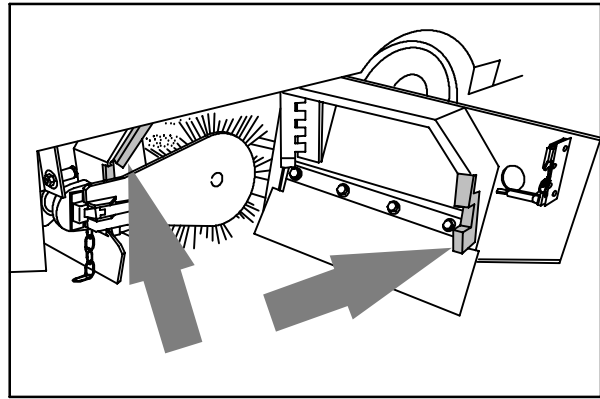

08022

HOPPER SEALS

The hopper seals are located on the top and side portions of the machine frame that contact the hopper. They seal the main brush compartment. Tighten the seal hardware to 4-5 Nm (3-4 ft lb).

Check the seals for wear or damage every 100 hours of operation.

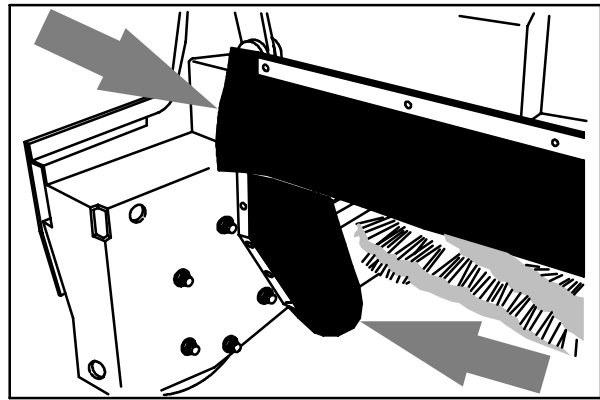

08023

TO REPLACE HOPPER SEALS

1. Park the machine on a smooth, level surface.
2. Stop the engine and set the machine parking brake.

FOR SAFETY: Before Leaving Or Servicing Machine; Stop On Level Surface, Set Parking Brake, Turn Off Machine And Remove Key.

3. Raise hopper and engage hopper support bar.

⚠ WARNING: Raised Hopper May Fall. Engage Hopper Support Bar.

4. Open the main brush doors.
5. Remove the main brush.

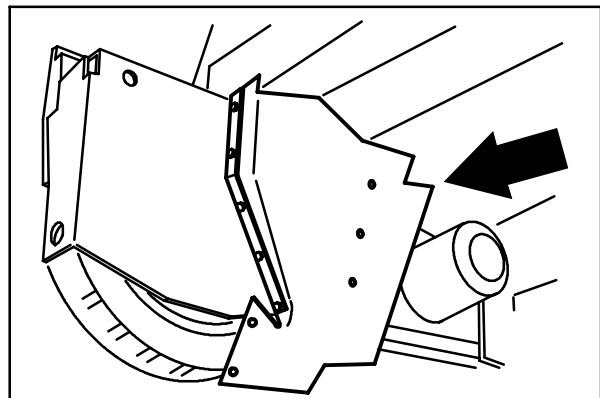

SWEEPING

6. Remove the skirt retainer and skirt on each side of the machine. Remove the plastic rivets by prying under the head.
7. Position new skirt and existing retainer on front of machine frame. Secure with plastic push-in rivets.
8. Pull skirt around inside of frame. Push skirt all of the way in its slots. Secure with existing angle retainer and two M6 bolts, flat washers, and Nyloc nuts. Tighten bolts to 4-5 Nm (3-4 ft lb).
9. Pull skirt toward the brush door. Secure it in place with the C-shaped retainer and bolts. Tighten the bolts to 8-10 Nm (6-8 ft lb).
10. Repeat for the other side of the main frame.

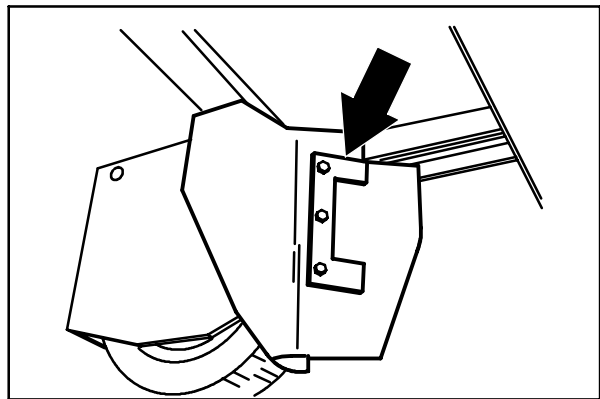
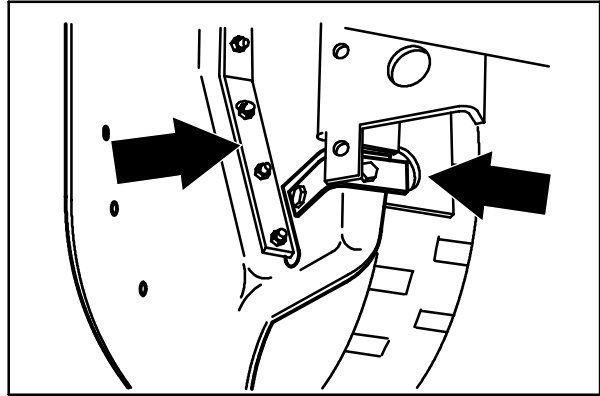

HOPPER INSPECTION DOOR SEAL

The hopper inspection door seal is located on the hopper and seals the front of the debris hopper.

Check the seal for wear or damage every 100 hours of operation.

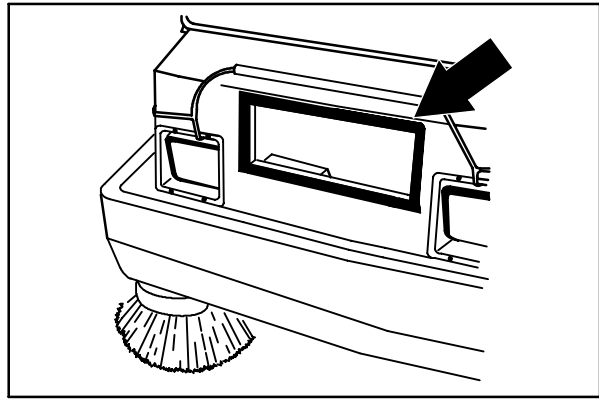

HOPPER DOOR SEALS

The hopper door seals are located on the hopper door. They seal the hopper when the hopper door is closed. Use RTV between the sponge cord and door seal. Make sure the seals are straight. Tighten hardware to 3–4 Nm (2.5–3.5 ft lb). Hardware should be oriented with the nyloc nuts on the top side of the door.

Check the seals for wear or damage every 100 hours of operation.

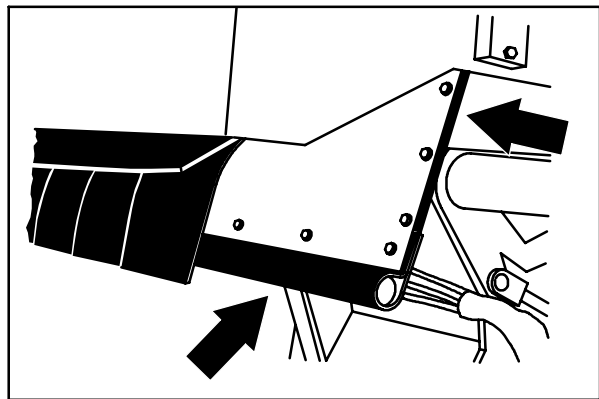

SWEEPING

TO REPLACE HOPPER DOOR SEALS

1. Park the machine on a smooth, level surface.
2. Open the hopper dump door.
3. Stop the engine and set the machine parking brake.

FOR SAFETY: Before Leaving Or Servicing Machine; Stop On Level Surface, Set Parking Brake, Turn Off Machine And Remove Key.

4. Raise the hopper and engage the hopper support bar.

⚠ WARNING: Raised Hopper May Fall. Engage Hopper Support Bar.

5. Remove the six M6 hex screws and nyloc nuts holding dump door seal, retainer, and sponge cord to dump door. Discard the seal.
6. Use black RTV to hold the sponge cord to the new dump door seal.
7. Align the holes in the new seal with holes on dump door and retainer. Reinstall the six M6 hex screws and nyloc nuts. Tighten to 3.3 – 4.4 Nm (30 – 39 In lb).
8. Remove the four M6 hex screws and nyloc nuts holding the dump door side seals and retainers to each side of the dump door. Note the direction of the hardware. Discard the seals.
9. Align the holes in the seal with the holes on the dump door and retainer. Reinstall the four M6 hex screws and nyloc nuts. Tighten to 3.3 – 4.4 Nm (30 – 39 In lb).

NOTE: Make sure the seals are lined up with the inside edge of the hopper when tightening.

10. Start the machine and lower the hopper.

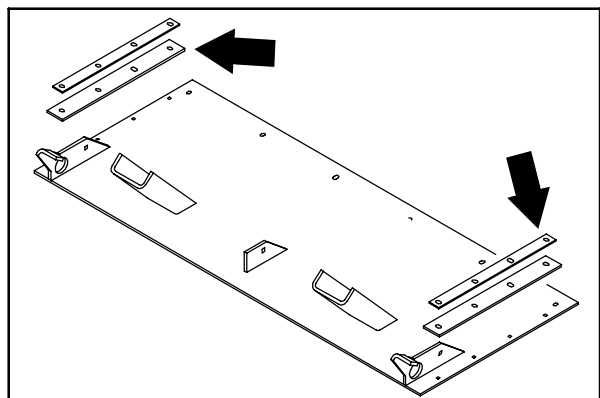
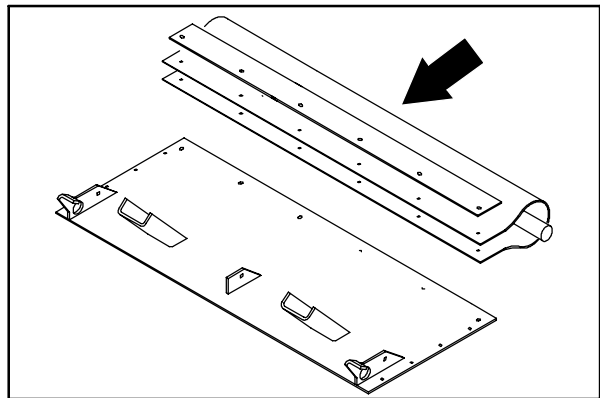
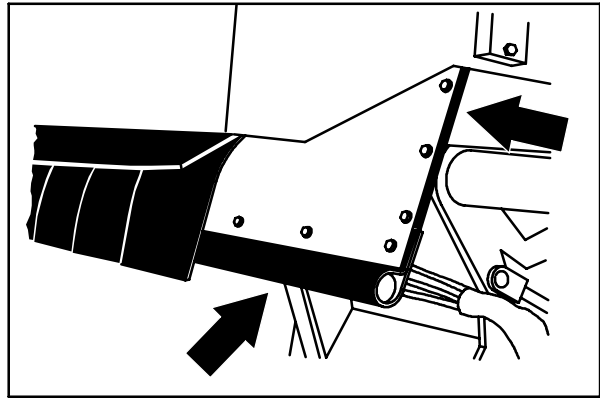

HOPPER COVER SEAL

The hopper cover seal is located on the top edges of the hopper insert. It seals the hopper filter compartment when the hopper cover is in the down position.

Check the seal for wear or damage every 100 hours of operation.

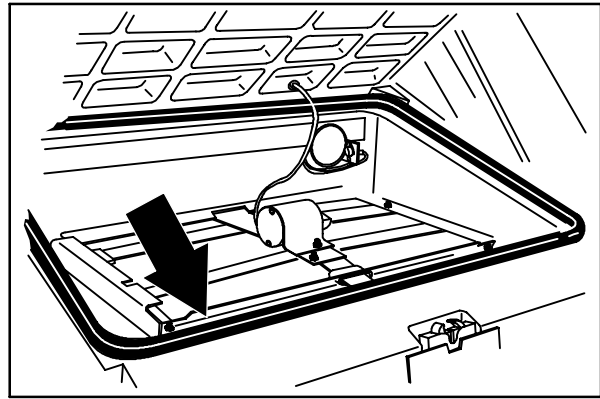

TO REPLACE HOPPER COVER SEAL

1. Park the machine on a smooth, level surface.
2. Stop the engine and set the machine parking brake.

FOR SAFETY: Before Leaving Or Servicing Machine; Stop On Level Surface, Set Parking Brake, Turn Off Machine And Remove Key.

3. Raise the hopper cover, unplug the wires from filter shaker and thermo-sentry, remove the filter carrier tray from the hopper and set it on the floor.
4. Remove the old rubber bubble seal from the filter carrier tray. The seal is glued to the tray so a putty knife or a razor blade knife is needed for removal.
5. Make sure the new seal is cut to the same length as the old seal.
6. Use super glue in the groove of the new seal and install it, bubble side up, on the filter tray.
7. Reinstall the filter carrier tray back in the hopper. Reconnect the shaker motor and thermo-sentry to the hopper harness.
8. Close the hopper cover and operate the machine. Check the new seal for any air leaks.

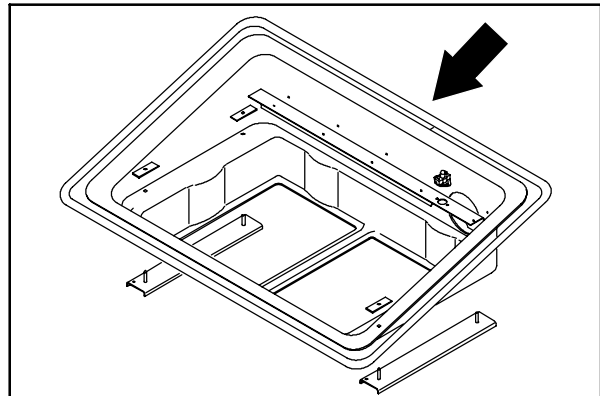

SWEEPING

HOPPER DUST SEAL

The hopper dust seal is located under the hopper insert along the top of the hopper.

Check the seal for wear or damage every 100 hours of operation. You can reach the seal by removing the hopper insert.

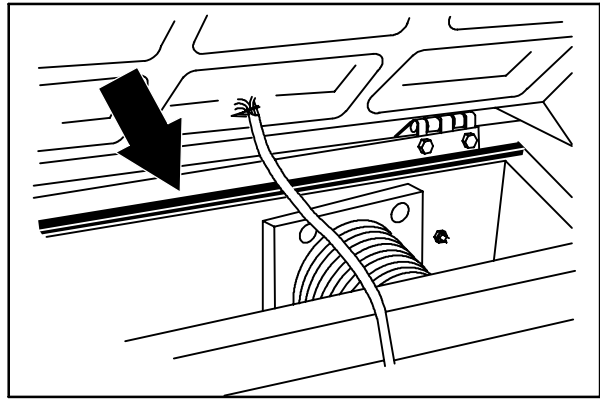

TO REPLACE HOPPER DUST SEAL

1. Park the machine on a smooth, level surface.
2. Stop the engine and set the machine parking brake.

FOR SAFETY: Before Leaving Or Servicing Machine; Stop On Level Surface, Set Parking Brake, Turn Off Machine And Remove Key.

3. Raise the hopper cover, unplug the wires from filter shaker and thermo-sentry, remove the filter carrier tray from the hopper and set it on the floor.
4. Using a scraper or a putty knife, remove the old seal from the back of the hopper. Discard the old seal.
5. Make sure that all of the old seal is removed before attempting to glue the new one on.
6. Cut the new seal to length and use an industrial strength contact cement to attach it to the back of the hopper.
7. Reinstall the filter carrier tray back in the hopper. Reconnect the shaker motor and thermo-sentry to the hopper harness.
8. Close the hopper cover and operate the machine. Check the new seal for any air leaks.

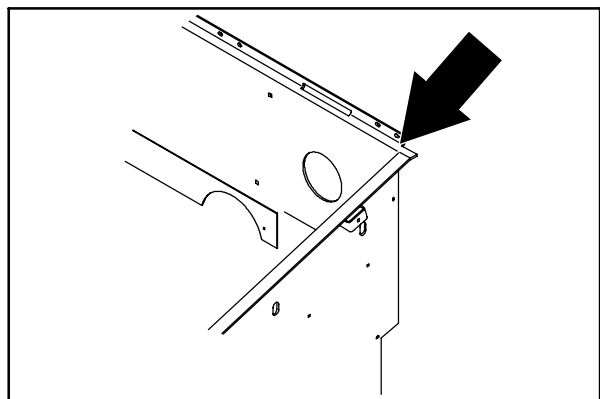

HOPPER VACUUM FAN SEAL

The hopper vacuum fan seal is mounted on the inside of the hopper around the vacuum fan inlet.

Check the seal for wear or damage every 100 hours of operation. You can reach the seal by removing the hopper insert.

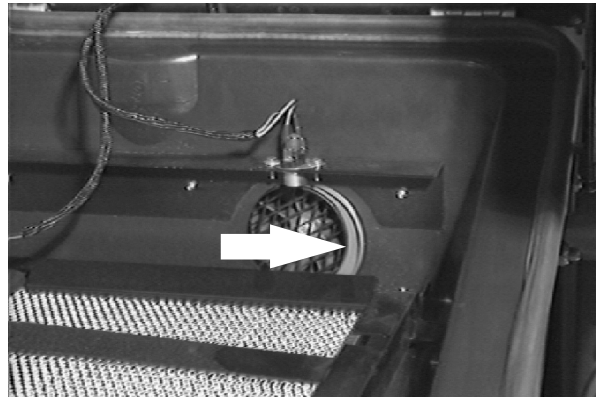

TO REPLACE HOPPER VACUUM FAN SEAL

1. Park the machine on a smooth, level surface.
2. Stop the engine and set the machine parking brake.

FOR SAFETY: Before Leaving Or Servicing Machine; Stop On Level Surface, Set Parking Brake, Turn Off Machine And Remove Key.

3. Raise the hopper cover, unplug the wires from filter shaker and thermo-sentry, remove the filter carrier tray from the hopper and set it on the floor.
4. Using a scraper or a putty knife, remove the old seal from the back of the hopper. Discard the old seal.
5. Make sure that all of the old seal is removed before attempting to glue the new one on.
6. Cut the new seal to length and use an industrial strength contact cement to attach it to the back of the hopper.
7. Reinstall the filter carrier tray back in the hopper. Reconnect the shaker motor and thermo-sentry to the hopper harness.
8. Close the hopper cover and operate the machine. Check the new seal for any air leaks.

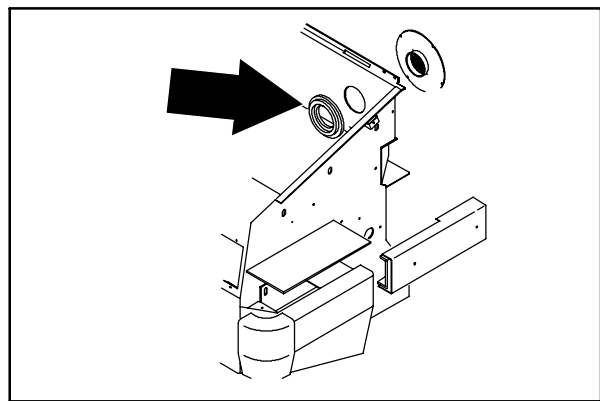

SWEEPING

HOPPER LIFT ARMS

The hopper lift arms lift and lower the hopper assembly. They are held in place by two pins and self-aligning bearings with retaining rings.

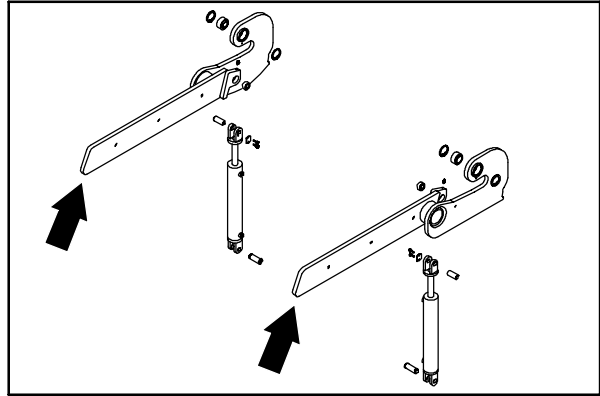

TO REMOVE HOPPER LIFT ARMS

1. Park the machine on a smooth, level surface.
2. Stop the engine and set the machine parking brake.

FOR SAFETY: Before Leaving Or Servicing Machine; Stop On Level Surface, Set Parking Brake, Turn Off Machine And Remove Key.

3. Remove the hopper. See TO REMOVE HOPPER instructions in this section.
4. Remove the RH and LH tank panels.
5. Disconnect the speed limiter cable from RH side lift arm. The cable can be removed from the ball by pushing down on the sleeve around the ball joint end and prying it off.
6. Remove the M6 hex screw holding the cylinder pin plate to the cylinder clevis.
7. Raise up slightly on lift arm to take the pressure off the lift cylinder pin. Remove pin.
8. Remove the M8 socket screw from the upper lift arm pivot pin.
9. Raise up slightly on the lift arm to take pressure off the pivot pin. Remove the pivot pin and lift arm from the machine.
10. If the large self aligning bearing needs to be changed, remove the retaining rings and press the bearing out of the lift arm.
11. If the small self aligning bearing needs to be changed, press the bearing out of the lift arm.
12. Repeat this procedure on the LH side lift arm if needed.

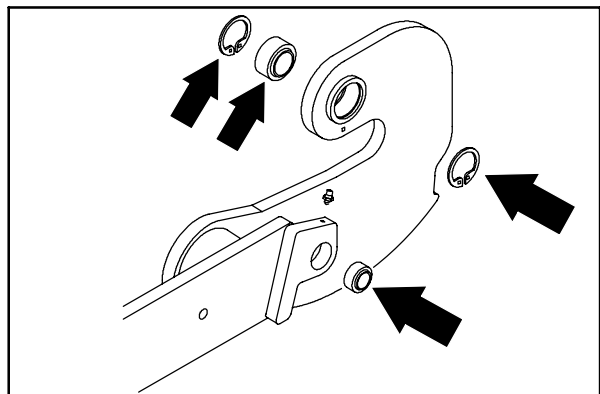
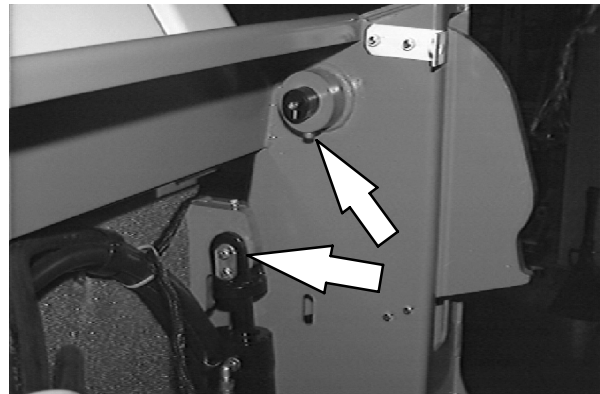
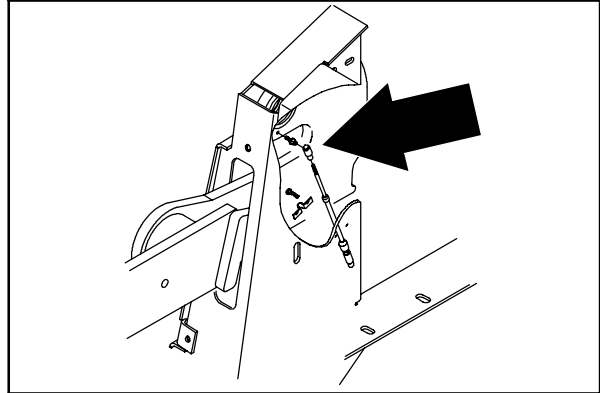

TO INSTALL HOPPER LIFT ARMS

1. Park the machine on a smooth, level surface.
2. Stop the engine and set the machine parking brake.

FOR SAFETY: Before Leaving Or Servicing Machine; Stop On Level Surface, Set Parking Brake, Turn Off Machine And Remove Key.

3. Position the lift arm in the machine. Align the large bearing with the upper hole in the machine frame tower.
4. Install the lift arm pivot pin through the large bearing from the outside of machine.
5. Align the hole in lift arm pivot pin with the hole in the pin boss on the machine frame tower. Install the M8 socket head screw and tighten to 18 - 24 Nm (13 - 18 ft lb).
6. Align the small bearing in the lift arm with the hole in the lift cylinder clevis.
7. Install the lift cylinder pin plate through the bearing. Reinstall the M6 hex screw and tighten to 8 - 10 Nm (6 - 8 ft lb).
8. On the RH lift arm, reconnect the speed limiter cable to the ball end.
9. Repeat steps 3 - 7 on the opposite side.
10. Reinstall hopper. See TO INSTALL HOPPER instructions in this section.

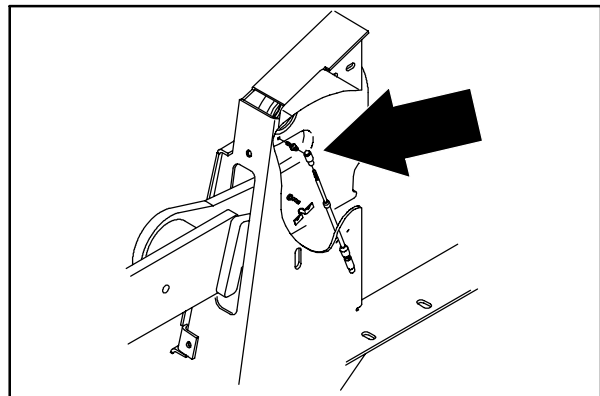
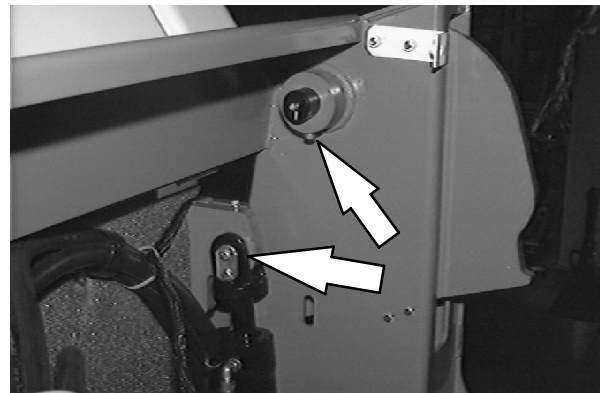
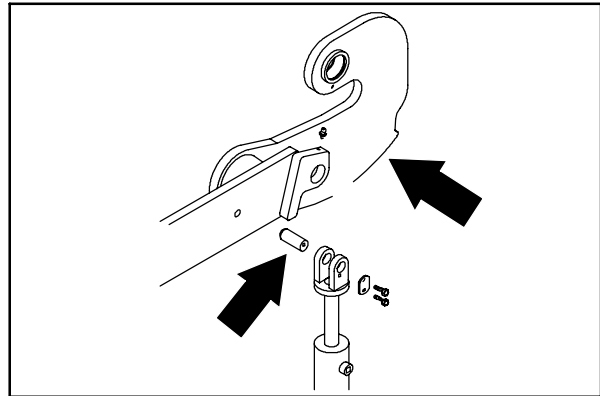

SWEEPING

SWEEPING VACUUM FAN

The sweeping vacuum fan is located on the back of the debris hopper. It is used during sweeping to control dusting by pulling air through the filters.

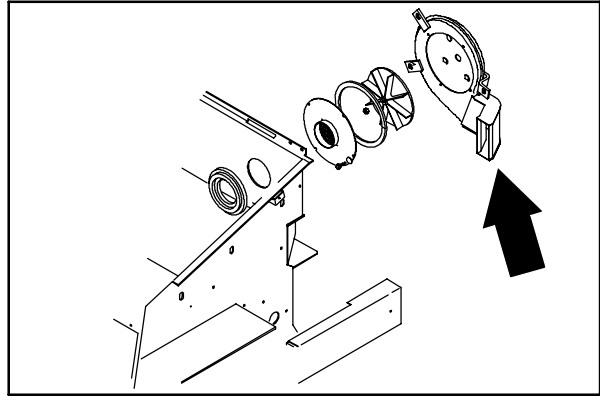

TO REMOVE SWEEPING VACUUM FAN

1. Park the machine on a smooth, level surface.
2. Stop the engine and set the machine parking brake.

FOR SAFETY: Before Leaving Or Servicing Machine; Stop On Level Surface, Set Parking Brake, Turn Off Machine And Remove Key.

3. Raise the hopper cover, unplug the wires from filter shaker and thermo-sentry, remove the filter carrier tray from the hopper and set it on the floor.
4. Leave the hopper cover open and raise the hopper 1/3 of the way up or far enough to access the three M10 hex screws holding the vacuum fan to the back of the hopper.

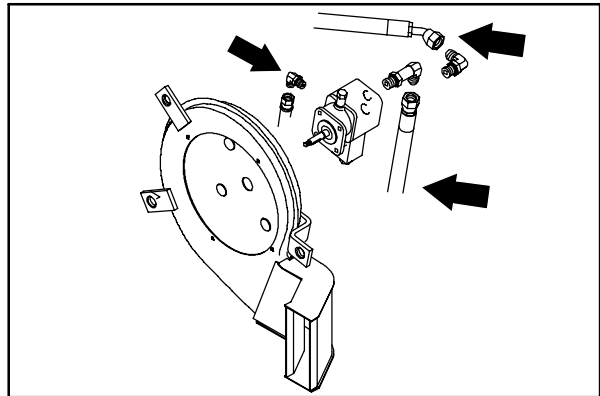

NOTE: Hopper must be held in this position with a hoist, jack stands or a prop rod between hopper bumper and machine frame.

5. Disconnect and plug the three hydraulic hoses on the vacuum fan motor.

NOTE: Observe hydraulic cleanliness requirements when opening hydraulic lines.

6. Disconnect the wire harness from the fan motor solenoid.
7. Remove the three M10 hex screws holding vacuum fan to rear of hopper. Reach in from the left side of the hopper, under the hopper cover, to access the hex screws.
8. Remove the vacuum fan assembly from the machine and make the necessary repairs.

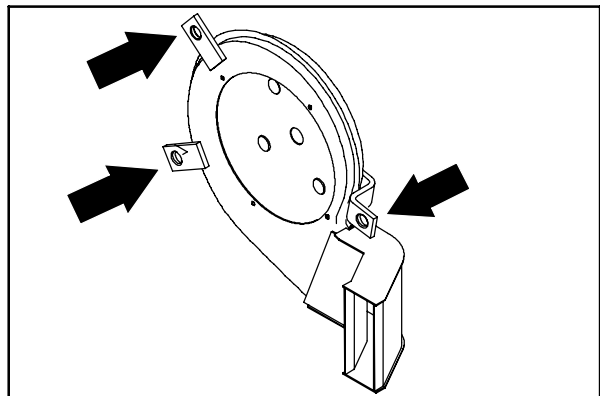

TO INSTALL SWEEPING VACUUM FAN

1. Park the machine on a smooth, level surface.
2. Stop the engine and set the machine parking brake.

FOR SAFETY: Before Leaving Or Servicing Machine; Stop On Level Surface, Set Parking Brake, Turn Off Machine And Remove Key.

3. Raise the hopper cover, unplug the wires from filter shaker and thermo-sentry, remove the filter carrier tray from the hopper and set it on the floor.
4. Leave the hopper cover open and raise the hopper 1/3 of the way up or far enough to access the three M10 hex screws holding the vacuum fan to the back of the hopper.

NOTE: Hopper must be held in this position with a hoist, jack stands or a prop rod between hopper bumper and machine frame.

5. Align the holes in fan isolators with the holes in the back of the hopper.
6. Reinstall the three M10 hex screws, washers and nyloc nuts with the nuts on the outside of the hopper. Tighten to 18 - 24 Nm (13 - 18 ft lb).
7. Reconnect hydraulic hoses. See schematic in HYDRAULICS section.
8. Reconnect the wire harness to the vacuum fan solenoid.
9. Make sure the wires and hoses are tied and clamped up properly.
10. Remove the hoist, jack stands or prop rod and lower the hopper.
11. Reinstall the filter carrier tray back in the hopper. Reconnect the shaker motor and thermo-sentry to the hopper harness.
12. Close the hopper cover and operate the machine. Check the sweeping vacuum fan for proper operation.

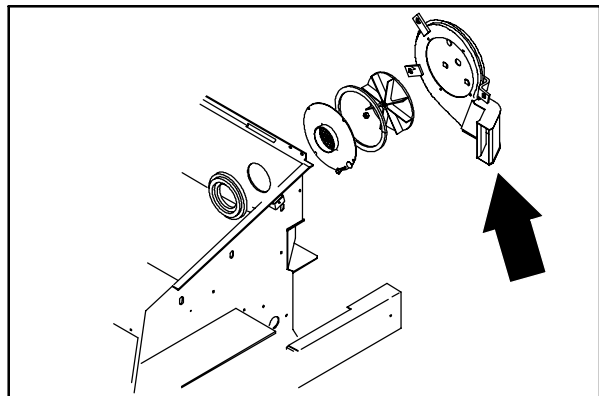
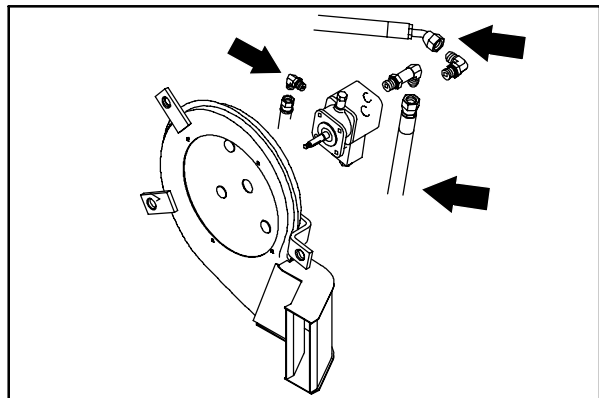
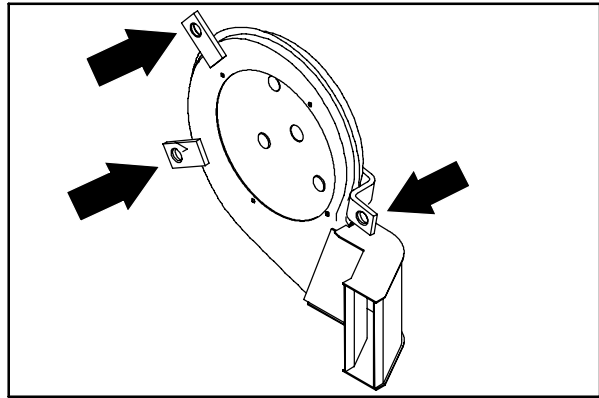

SWEEPING

TO REPLACE SWEEPING VACUUM FAN IMPELLER

1. Park the machine on a smooth, level surface.
2. Stop the engine and set the machine parking brake.

FOR SAFETY: Before Leaving Or Servicing Machine; Stop On Level Surface, Set Parking Brake, Turn Off Machine And Remove Key.

3. Remove the vacuum fan from the machine. See TO REMOVE SWEEPING VACUUM FAN instructions in this section.
4. Place the vacuum fan assembly in a vice.
5. Remove the four 0.25 in. hex screws and fender washers holding the inlet plate to the vacuum fan housing. Remove the plate.
6. Hold the impeller from turning and remove the 0.31 in. hex nut from the vacuum fan motor shaft.
7. Pull the impeller straight off the shaft. The impeller may have to be lightly pried off. Be careful not to loose the square key.
8. Put a small amount of grease on the motor shaft before installing the new impeller. Make sure the square key is in place.
9. Slide the impeller all the way on the shaft and spin it slowly. If the impeller rubs on housing pull it back off and place a 0.38 in. flat washer on shaft under impeller and re-assemble. Repeat this procedure until the impeller spins freely.
10. Hold the new impeller from turning and firmly tighten the 0.31 in. flex lock nut.
11. Reinstall the inlet plate using the four 0.25 in. hex screws and fender washers. Tighten to 11 - 14 Nm (7 - 10 ft lb).
12. Reinstall vacuum fan assembly to the rear of the hopper. See TO INSTALL SWEEPING VACUUM FAN instructions in this section.

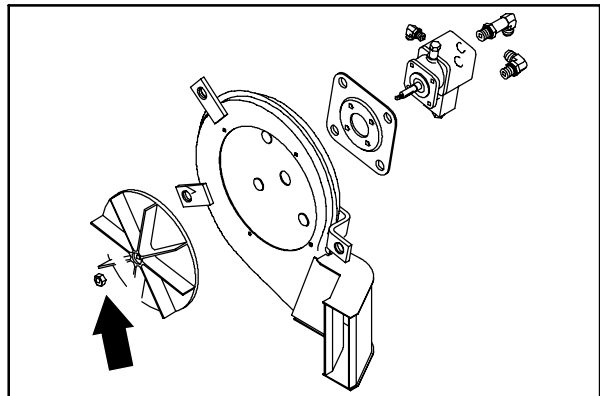
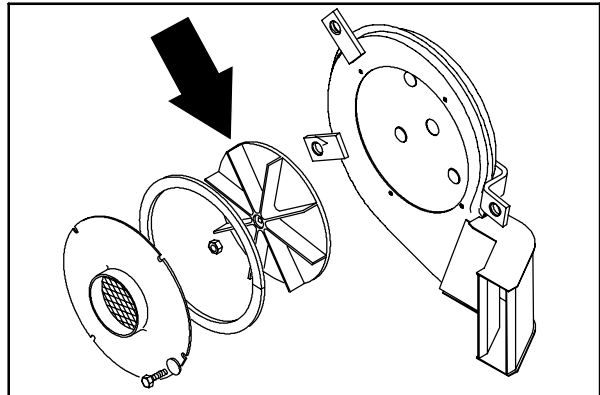
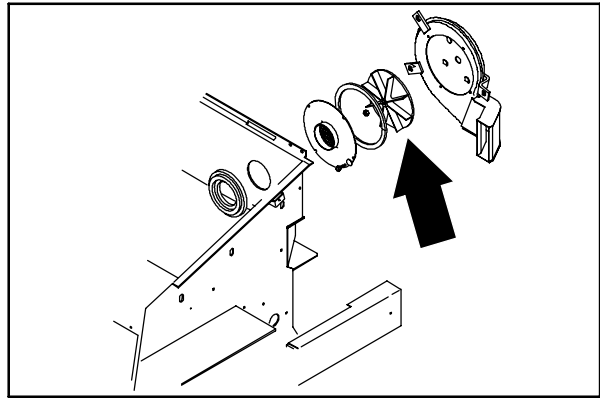

MACHINE TROUBLESHOOTING

| Problem | Cause | Remedy |
|---------------------------|--|--|
| Excessive dusting | Brush skirts and dust seals worn, damaged, out of adjustment | Replace or adjust brush skirts or dust seals |
| | Hopper dust filter clogged | Shake and/or clean or replace dust filter |
| | Vacuum hose damaged | Replace vacuum hose |
| | Vacuum fan failure | Contact TENNANT service personnel |
| | Thermo Sentry™ tripped | Reset Thermo Sentry™ |
| Poor sweeping performance | Brush bristles worn | Replace brushes |
| | Main and side brushes not adjusted properly | Adjust main and side brushes |
| | Debris caught in main brush drive mechanism | Free drive mechanism of debris |
| | Main brush drive failure | Contact TENNANT service personnel |
| | Side brush drive failure | Contact TENNANT service personnel |
| | Hopper full | Empty hopper |
| | Hopper lip skirts worn or damaged | Replace lip skirts |
| | Wrong sweeping brush | Contact TENNANT representative for recommendations |

CONTENTS

| | Page |
|--|------|
| INTRODUCTION | 4-3 |
| SOLUTION SYSTEM | 4-4 |
| RECOVERY TANK | 4-4 |
| TO REMOVE RECOVERY TANK | 4-4 |
| TO INSTALL RECOVERY TANK | 4-7 |
| SOLUTION TANK | 4-8 |
| TO REMOVE SOLUTION TANK | 4-9 |
| TO INSTALL SOLUTION TANK | 4-10 |
| SCRUB HEAD | 4-11 |
| TO REMOVE SCRUB HEAD | 4-11 |
| TO INSTALL SCRUB HEAD | 4-14 |
| TO REPLACE SIDE SHIFT CABLE | 4-16 |
| SQUEEGEES | 4-17 |
| TO REPLACE SQUEEGEE PUSH-PULL CABLE | 4-17 |
| TO REPLACE SQUEEGEE LIFT CABLE | 4-19 |
| TO REMOVE REAR SQUEEGEE FRAME | 4-20 |
| TO INSTALL REAR SQUEEGEE FRAME | 4-21 |
| LEVELING THE REAR SQUEEGEE | 4-23 |
| ADJUSTING REAR SQUEEGEE BLADE DEFLECTION | 4-24 |
| SQUEEGEE BLADES | 4-25 |
| REAR SQUEEGEE | 4-25 |
| REPLACING OR ROTATING REAR SQUEEGEE BLADES | 4-25 |
| SIDE SQUEEGEES | 4-26 |
| REPLACING SIDE SQUEEGEE BLADES | 4-26 |
| SCRUB VACUUM FAN | 4-27 |
| TO REMOVE SCRUB VACUUM FAN | 4-27 |
| TO INSTALL SCRUB VACUUM FAN | 4-28 |
| MACHINE TROUBLESHOOTING ... | 4-29 |

INTRODUCTION

When the scrubbing mode is used, water flows from the solution tank through the solution valve to the three disc scrub brushes. The brushes scrub the floor. As the machine is moved forward the squeegee wipes the dirty solution off the floor, which is then picked up and drawn into the recovery tank by the vacuum fan.

SOLUTION SYSTEM

RECOVERY TANK

The recovery tank stores recovered solution. The recovery tank should be drained and cleaned daily, or when the recovery tank full light comes on.

ES™ option: The ES™ filter should be cleaned daily. The ES™ filter can be rinsed while in the recovery tank through the right tank fill opening, or by removing the ES™ pump from the recovery tank.



TO REMOVE RECOVERY TANK

FOR SAFETY: Before Leaving Or Servicing Machine; Stop On Level Surface, Set Parking Brake, Turn Off Machine And Remove Key.

1. Drain the recovery tank.

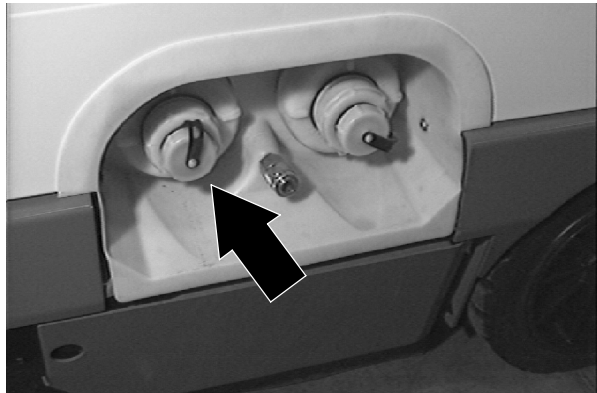

2. Open the engine cover and side door.

3. Loosen the four M8 hex screws holding the lintel cover to the machine. Remove the cover.

4. Start the engine, raise the hopper, and engage the safety leg.

⚠ WARNING: Raised Hopper May Fall. Engage Hopper Support Bar.

5. Disconnect the vacuum hose and squeegee hose from the back of the recovery tank.

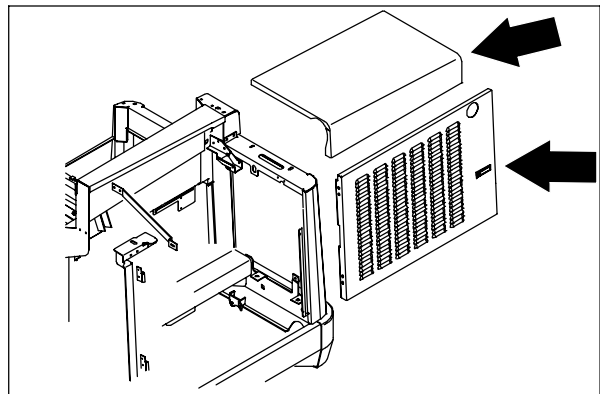

6. Remove the six M6 hex screws holding the LH side panel to the machine. Remove the panel.
7. Remove the three M6 hex screws holding the plastic clean out cover to the machine. Remove the drain hoses, caps and clean out cover. If the machine is equipped with the ES™ option, remove the solution hose from the brass fitting.
8. Remove the three M6 hex screws and one M8 hex screw holding the RH side panel to the machine. Remove the panel.
9. Remove the M8 hex screws holding the recovery tank to the machine. This hardware is located near tank drain opening and the center of the machine.
10. Remove the four M8 hex screws holding the engine side door mount bracket to the back of the recovery tank. Remove the mount bracket.

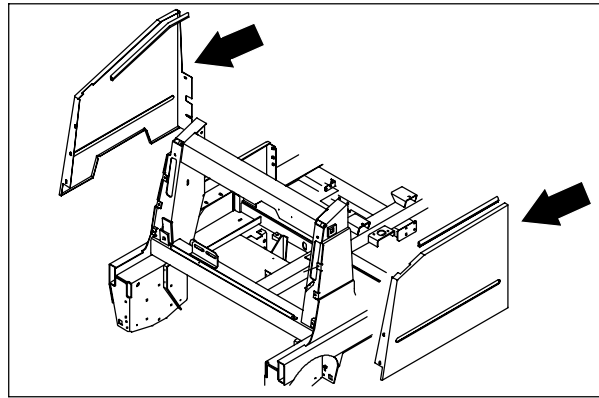

11. If the machine is equipped with the ES™ or auto-fill option, remove the hoses connected to the recovery tank.

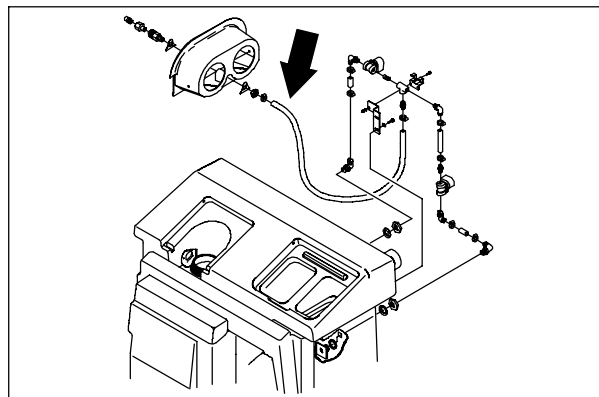
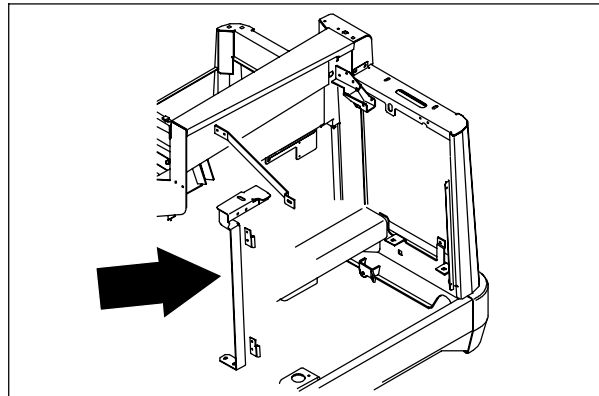

SCRUBBING

12. Remove black plastic check valve from the top of the solution tank.

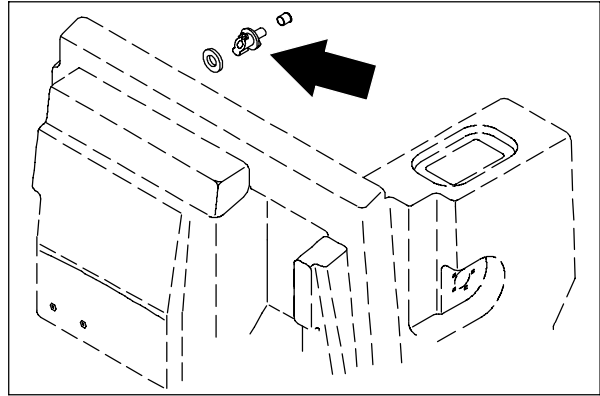

13. If the machine is equipped with the ES™ option, remove the wires connected to the float switch on the recovery tank.
14. The recovery tank can now be removed. Some careful maneuvering of the tank will be needed to get it to come out easily because of the tight fit. Lift the tank straight up and out of machine. Leave the outer ring of the tank cap on the threads to protect it from damage during removal.

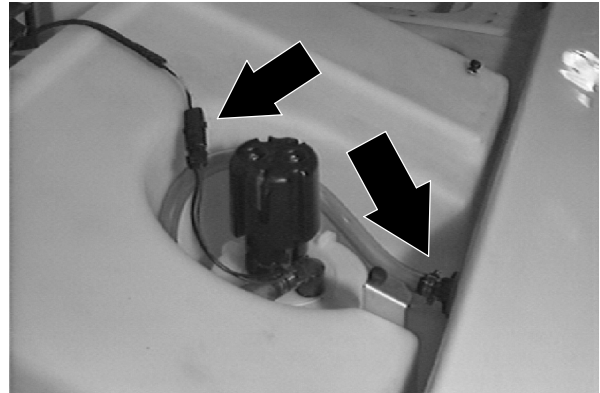

NOTE: The hardware can be loosened on the solution tank to ease removal of recovery tank.

TO INSTALL RECOVERY TANK

FOR SAFETY: Before Leaving Or Servicing Machine; Stop On Level Surface, Set Parking Brake, Turn Off Machine And Remove Key.

NOTE: Be careful not to pinch hydraulic hoses or electrical wires during this procedure.

1. Position the recovery tank in the machine. This is a tight fit. With careful maneuvering the tank will slip in. Leave the outer ring of the tank cap on the threads to protect it from damage during installation.

NOTE: The hardware can be loosened on the solution tank to ease installation of recovery tank.

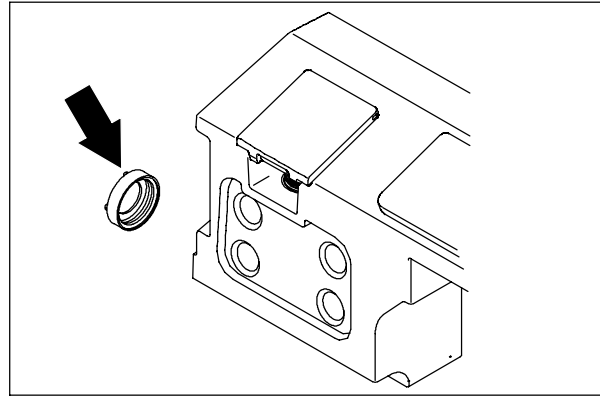

2. Align the three holes in the right hand side of machine, near the tank drain hole area, with the three threaded inserts in the recovery tank. Install the three M8 SS hex screws and washers, leave loose for now.
3. Reinstall the vacuum hose and squeegee hose to the back of the recovery tank.

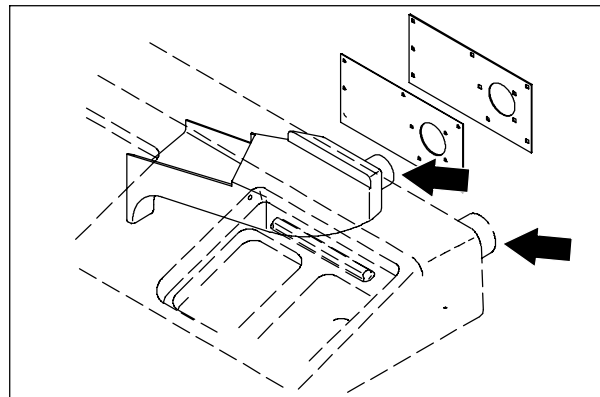

4. Reinstall the black plastic check valve in the top of the solution tank.
5. Reinstall the left hand side panel.

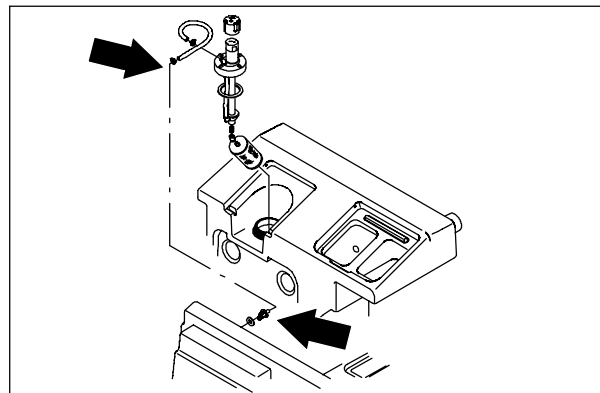

SCRUBBING

6. Reinstall the door mount bracket to the back of the recovery tank and frame using the M8 hex screws and washers. Tighten to 18 - 24 Nm (13 - 15 ft lb).
7. Go back and tighten the three M8 hex screws on recovery tank near the tank drain area. Tighten to 18 - 24 Nm (13 - 15 ft lb).
8. If the machine is equipped with the ES™ option, Reinstall the hoses to the fittings on the back of the solution tank.
9. If the machine is equipped with the ES™ option, reconnect the wires to the float switch on the right side of the tank. See schematic in the ELECTRICAL section.
10. Reinstall the right hand side panel on the machine using the six M6 hex screws and washers. Tighten to 8 - 10 Nm (5 - 7 ft lb).
11. Reinstall the plastic clean out cover using the three M6 hex screws and washers. Tighten to 8 - 10 Nm (5 - 7 ft lb). Reinstall tank caps and hoses.
12. Start the engine, disengage the safety arm, and lower the hopper.
13. Reinstall the lintel cover and lightly hand tighten the four M8 hex screws.
14. Lower the engine cover and side door.

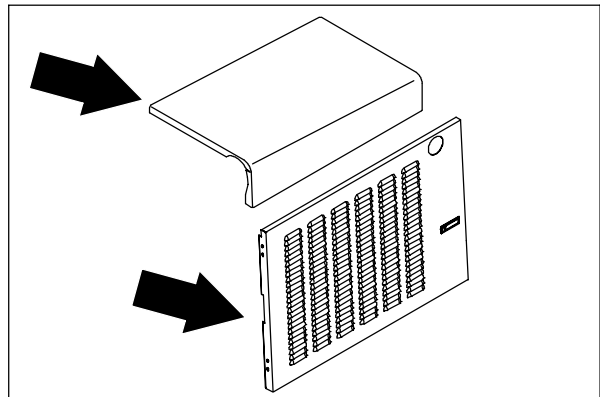
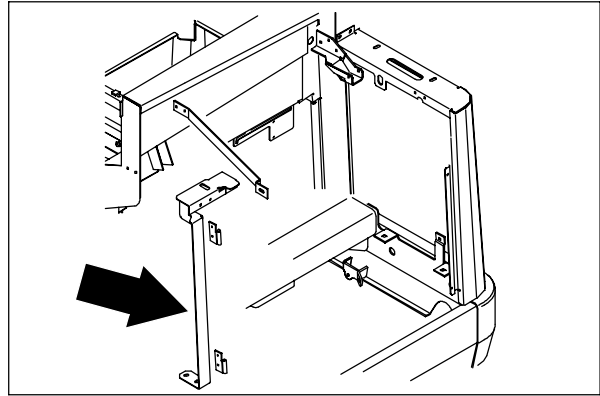

SOLUTION TANK

The solution tank contains the cleaning solution.

The solution tank does not require regular maintenance. If deposits form on the bottom of the tank, rinse the tank with a strong blast of warm water. The right tank can be flushed through the drain opening. Drain the tank with the solution tank drain hose.

The solution tank on machines with the ES™ option should be drained and cleaned daily. Rinse the solution outlet filters at the bottom of the tank through the drain access.

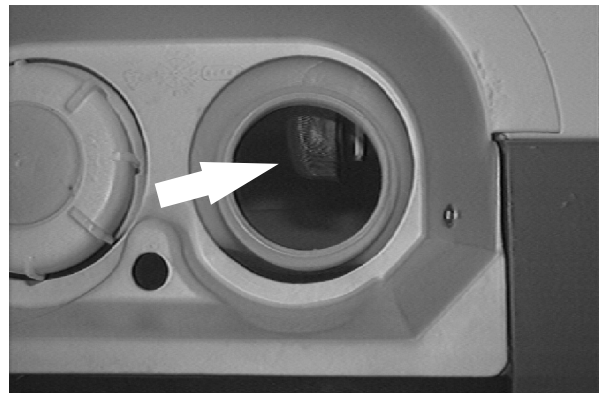

TO REMOVE SOLUTION TANK

FOR SAFETY: Before Leaving Or Servicing Machine; Stop On Level Surface, Set Parking Brake, Turn Off Machine And Remove Key.

1. Drain the solution and recovery tanks. **The recovery tank must be removed *before* the solution tank can be removed.** See TO REMOVE RECOVERY TANK instructions.

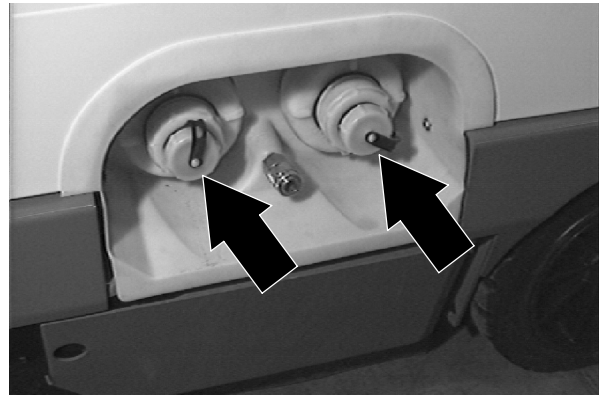

2. Remove the four M8 hex screws holding the solution tank to the machine frame. Make sure to retain the two plated clamps from the front of the tank.

3. Lift the solution tank slightly and remove the solution lines from the electric water solenoids.

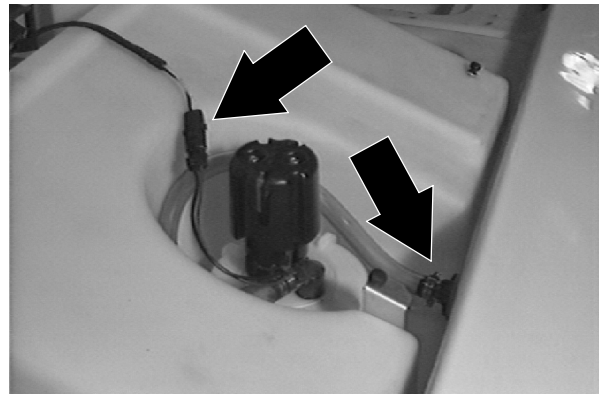

4. Remove the M8 nyloc nut and clamp holding the hydraulic hoses to the front of the solution tank.

5. The solution tank can now be removed. Some careful maneuvering of the tank will be needed to get it to come out easily straight up and out of machine. Leave the outer ring of the tank cap on the threads to protect it from damage during removal.

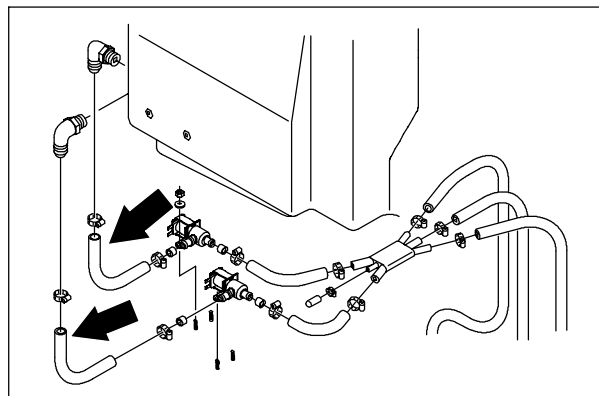

SCRUBBING

TO INSTALL SOLUTION TANK

FOR SAFETY: Before Leaving Or Servicing Machine; Stop On Level Surface, Set Parking Brake, Turn Off Machine And Remove Key.

1. Position solution tank in the machine. Be careful not to damage the face of the drain outlet hole when placing tank in the machine. Do not install any hardware at this time.

NOTE: Be careful not to pinch any hydraulic hoses or electrical wires during this procedure.

2. Make sure the solution hoses are on the fittings on the right side of the tank.
3. Align the holes in the left hand side of machine, near the main valve area, with the threaded inserts in the solution tank. Install the M8 SS hex screws and washers, leave loose for now.
4. Align the two holes in the front of the solution tank with the holes in the machine frame. Install the two M8 hex screws, washers and two plated clamps. Tighten to 18 - 24 Nm (13 - 15 ft lb).
5. Go back and tighten the M8 hex screws on solution tank near the main valve area. Tighten to 18 - 24 Nm (13 - 15 ft lb).
6. Reinstall hydraulic hoses, clamp and M8 nyloc nut to the front of the solution tank. Tighten to 18 - 24 Nm (13 - 15 ft lb).

NOTE: Do not install the ES™ fitting in the top of the solution tank until the recovery tank has been installed.

7. The recovery tank can now be installed. See TO INSTALL RECOVERY TANK instructions.

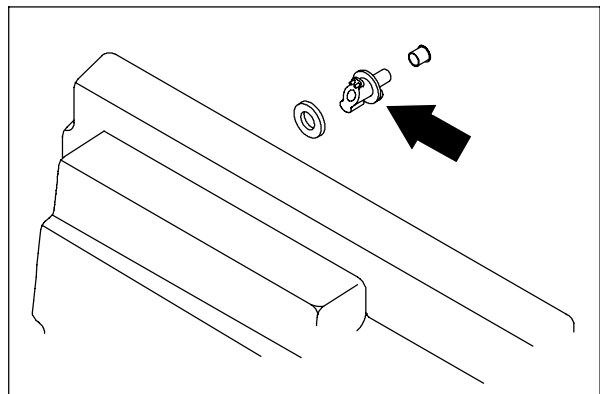
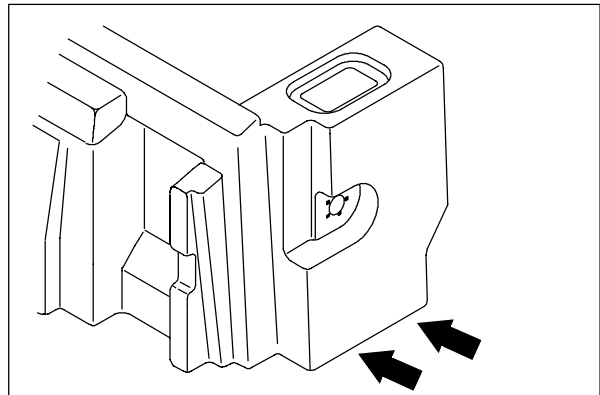
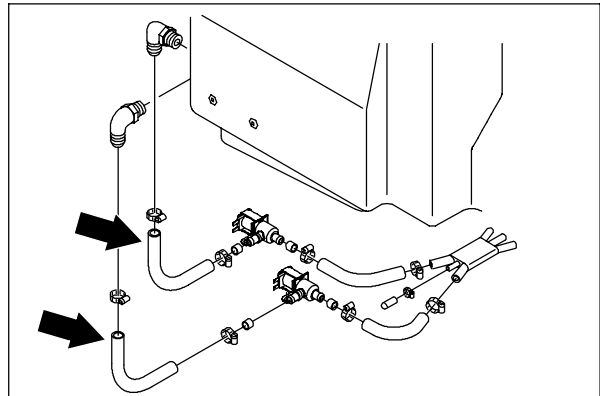
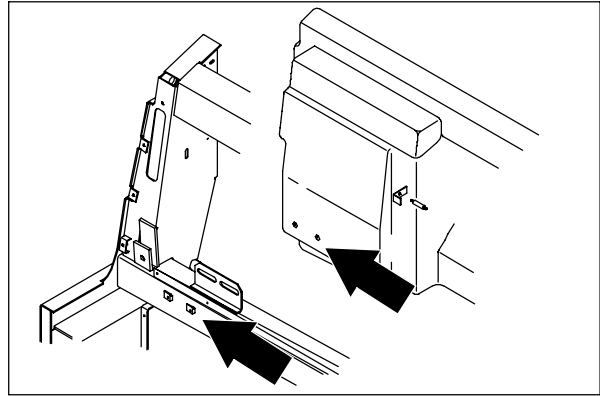

SCRUB HEAD

The scrub head encloses the scrub brushes and a solution dispensing system. The scrub head is located directly behind the sweeping brush compartment.

The scrub head is factory adjusted and the measurement should not be changed unless scrub head parts are damaged or are replaced.

The scrub head contains three disc brushes, hydraulic motors, lift cylinders and side squeegees. Each brush has its own hydraulic motor and lift cylinder. There is also a hydraulic cylinder that can shift the scrub head over to the right for superior edge cleaning. Water from the solution tank flows to the center of each brush.

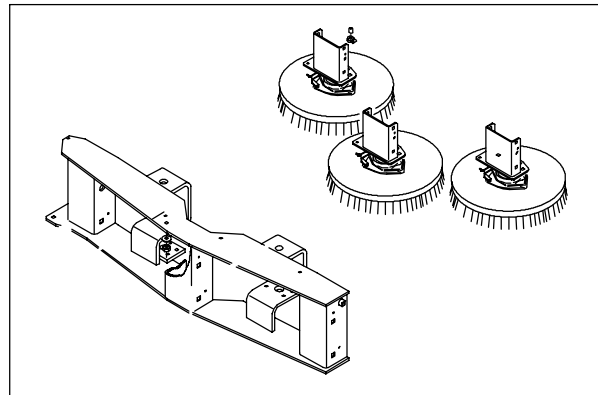

TO REMOVE SCRUB HEAD

1. Start the engine, lower and side shift the scrub head, shut off the engine.

FOR SAFETY: Before Leaving Or Servicing Machine; Stop On Level Surface, Set Parking Brake, Turn Off Machine And Remove Key.

2. Raise the rear of machine using a hoist or floor jack.

FOR SAFETY: Block machine tires before jacking machine up. Jack machine up at designated locations only. Block machine up with jack stands.

3. Remove the cotter pin from the long horizontal clevis pin holding each side squeegee to the scrub head frame. Remove the clevis pins and squeegee assemblies from both sides.

4. Remove all three scrub brushes.

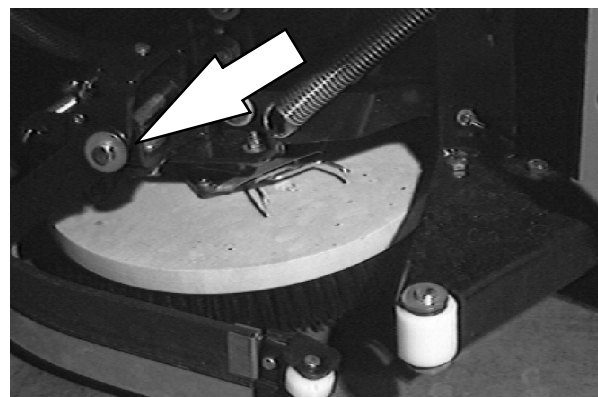

SCRUBBING

5. Remove the hex nut holding the balljoint and push-pull cable to the LH side squeegee bracket.
6. Loosen the large hex nut holding the cable to the cable bracket. Remove the cable from the bracket and place it out of the way for scrub head removal.

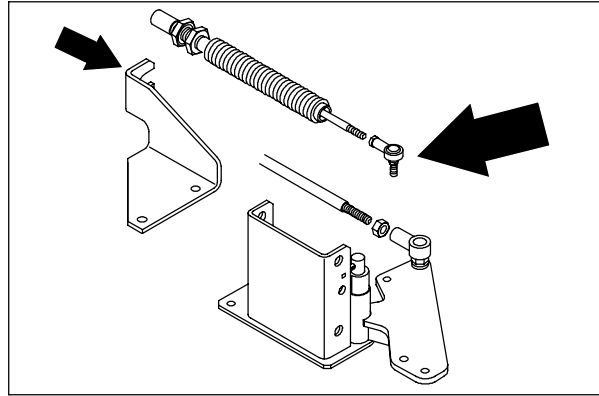

7. Locate the water flow manifold on the machine frame. Remove the three solution feed lines from the manifold. Some of the plastic ties will have to be removed from the water flow lines to do this.

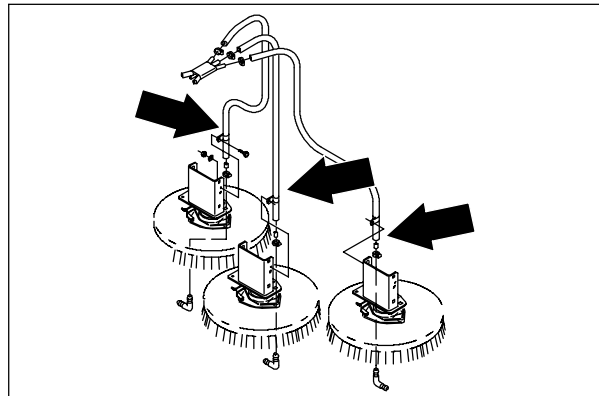

8. Locate the side shift gas spring and return cable on the top, front, center of the scrub head frame. Remove the small clip holding the gas spring ball end to the scrub head. Pop the gas spring off the ball end.
9. Remove the cotter pin and clevis from the return cable at the cylinder bracket.

NOTE: Mark the hoses for proper re-assembly.

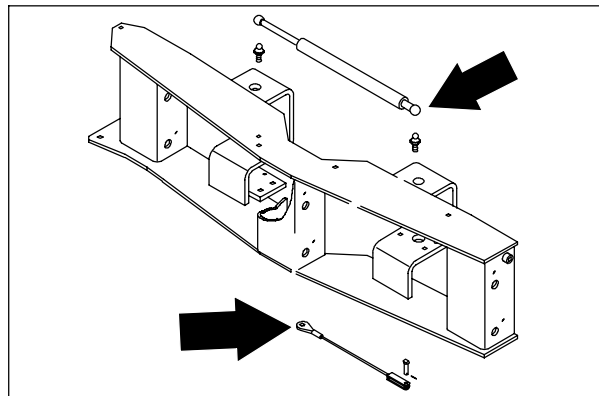

10. Disconnect and plug the two #4 hydraulic hoses leading from the control valve to the center scrub brush lift cylinder.

NOTE: Observe hydraulic cleanliness requirements when opening hydraulic lines.

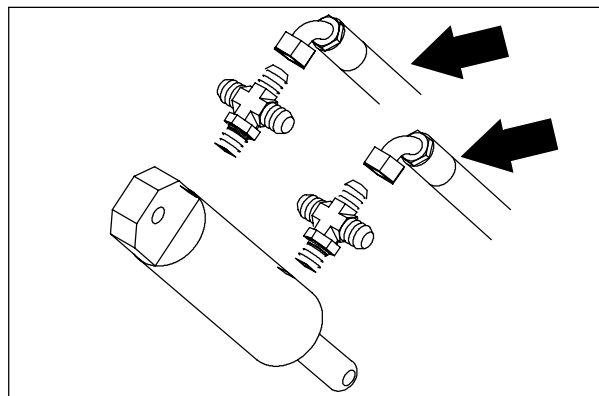

11. Disconnect and plug the two #8 hydraulic hoses leading from the control valve to the RH and LH scrub brush motors.

NOTE: Place a floor jack under the scrubber head to help hold it up when pins are removed.

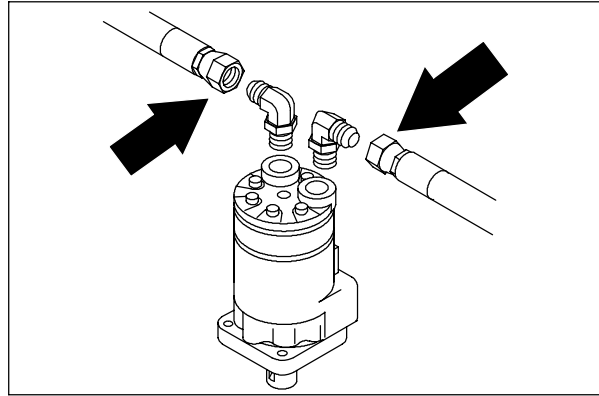

12. Remove the M6 hex screw and washer holding the cotter pin into the scrub head pin on the scrub head frame. Remove both pins.
13. The scrub head can now be removed from the machine.

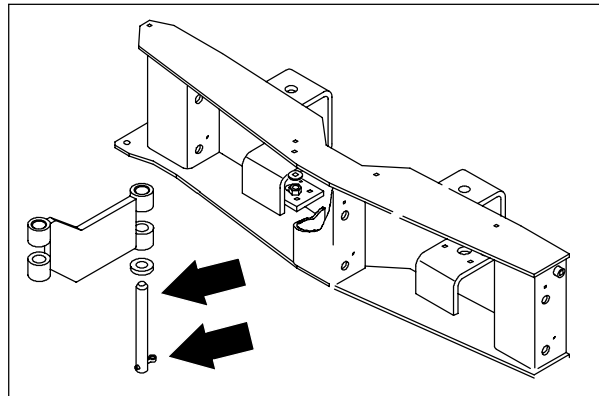

SCRUBBING

TO INSTALL SCRUB HEAD

FOR SAFETY: Before Leaving Or Servicing Machine; Stop On Level Surface, Set Parking Brake, Turn Off Machine And Remove Key.

1. Raise the rear of machine using a hoist or floor jack.

FOR SAFETY: Block machine tires before jacking machine up. Jack machine up at designated locations only. Block machine up with jack stands.

2. Position the scrub head under the machine using a floor jack.
3. Raise the head up and align the holes in the scrub head frame with holes in edge scrub link. Install the scrub head pins in from the bottom.
4. Align the hole in the pin with the cotter pin and hole in scrub head frame. Reinstall the M6 hex screw and washer through the hole in cotter pin. Tighten to 8 - 10 Nm (5 - 7 ft lb).
5. Reconnect the two #4 hydraulic hoses to the center lift cylinder and the two #8 hoses to the outside brush motors. See schematic in HYDRAULICS section.

NOTE: Make sure the scrub head is pulled over all the way to the right for the next operation.

6. Reconnect the side shift cable to the cylinder pivot bracket.
7. Install the gas spring ball end back on the ball on the scrub head. Make sure to reinstall the locking clip.
8. Reconnect the main solution feed line to the plastic, water manifold.

NOTE: Make sure to reinstall any clamps or plastic ties that were removed during disassembly.

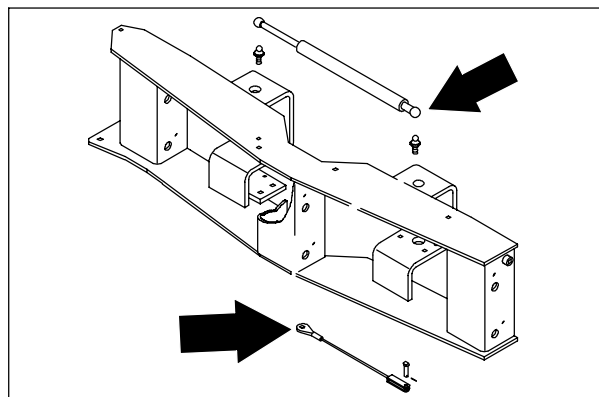
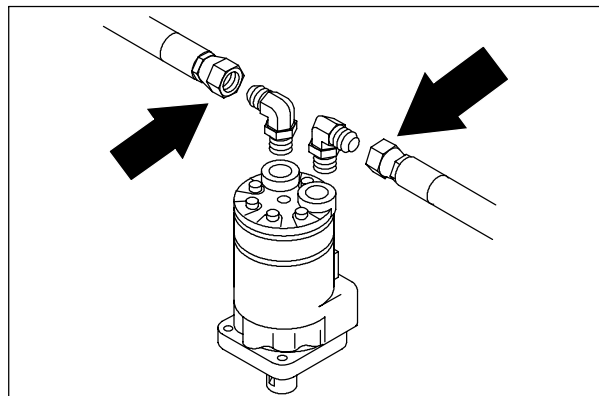
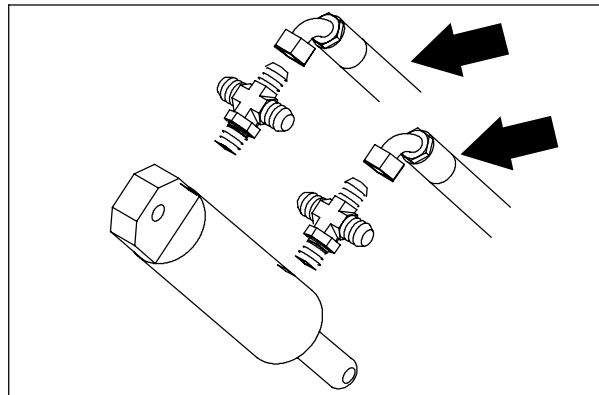
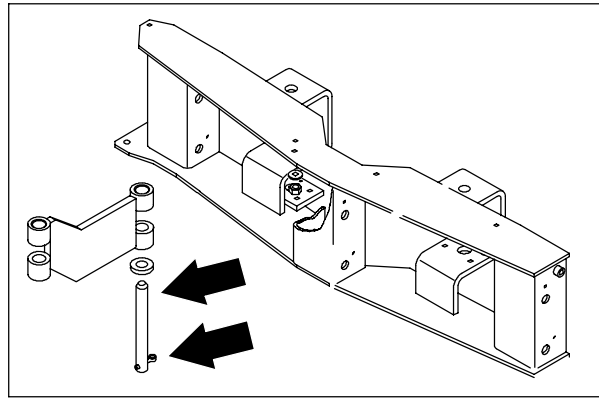

9. Position push-pull cable back in the mounting bracket and hand tighten large nut. Do not change the adjustment.
10. Reinstall the ball joint end of the push-pull cable back in the hole on side squeegee bracket. Tighten 0.31 in. hex nut to 18 - 24 Nm (13 - 18 ft lb).

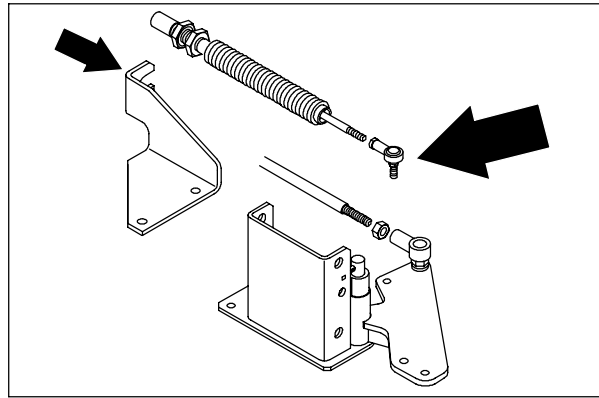

11. Reinstall the three disc brushes.

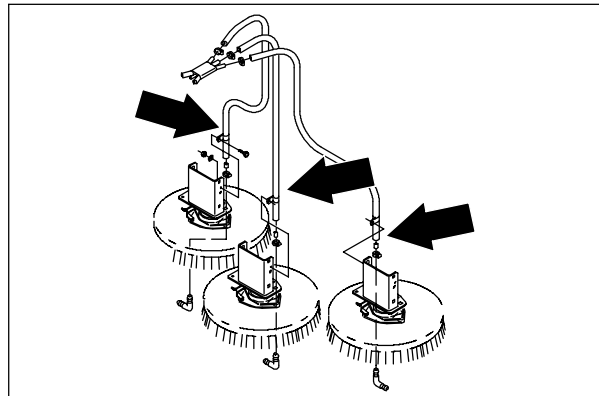

12. Reinstall the LH and RH side squeegees with the long clevis pins and cotter pins.
13. Lower the machine. Start the engine and check for any leaks and for proper operation of the scrub brushes and side shift.

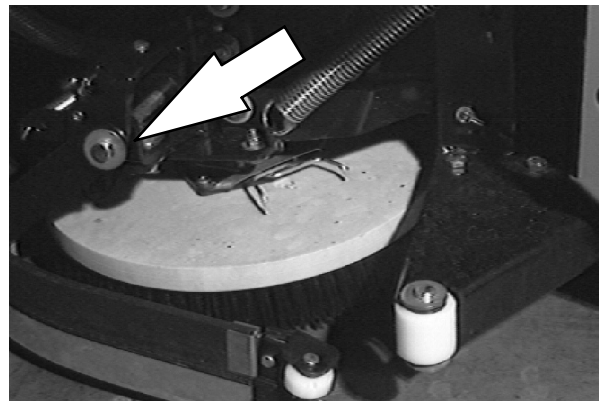

SCRUBBING

TO REPLACE SIDE SHIFT CABLE

1. Start the engine, lower and side shift the scrub head, shut off the engine.

FOR SAFETY: Before Leaving Or Servicing Machine; Stop On Level Surface, Set Parking Brake, Turn Off Machine And Remove Key.

2. Raise the rear of machine using a hoist or floor jack.

FOR SAFETY: Block machine tires before jacking machine up. Jack machine up at designated locations only. Block machine up with jack stands.

3. Go under the machine on the left side. Look up above the left hand scrub brush motor and to the right of the control valve. Locate the clevis pin holding the side shift cable to the pivot bracket. Remove the cotter and clevis pin.
4. Go under the machine on the right side and locate the M8 hex screw holding the other end of the side shift cable to the scrub head frame. Remove the M8 hex screw, nyloc nut, and cable from the machine.
5. Position the new cable back in the machine. Align the hole in the ring end of cable with the hole in scrub head frame. Reinstall the M8 hex screw and lightly tighten. The cable must be able to swivel after tightening.
6. Go under the machine on the left side and align the clevis end of the cable with the hole in the pivot bracket. Reinstall the clevis and cotter pin.
7. Lower the machine. Start the engine and check for proper side shift function.

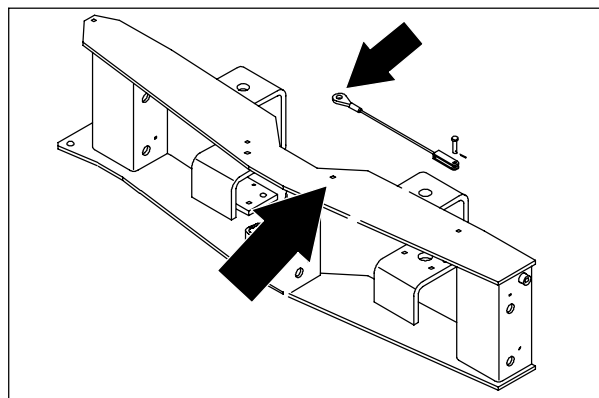
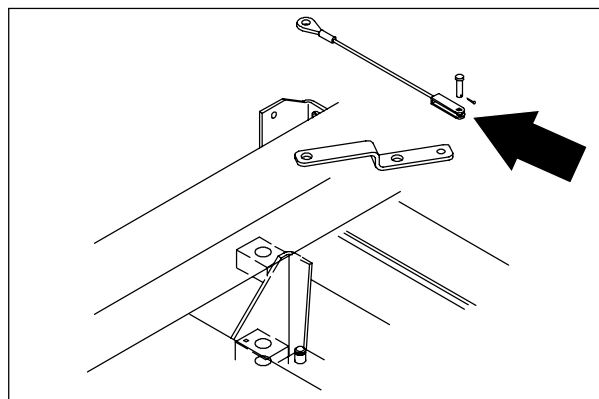
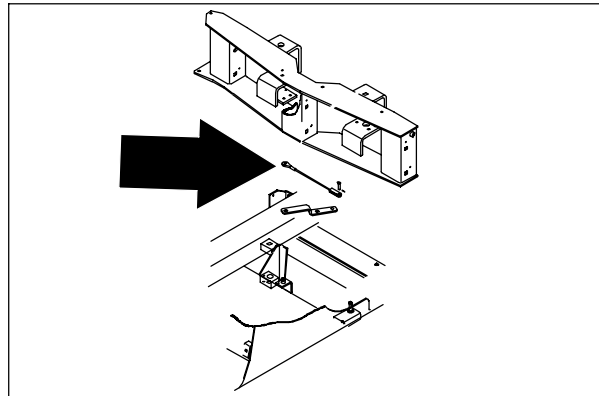

SQUEEGEES

The squeegee channels water into the vacuum fan suction. The front blade channels the water, and the rear blade wipes the floor.

There are two types of squeegee blades available; one for smooth surfaces is standard on the machine, and one for rough surfaces is an option.

Check the squeegee blades for damage and wear daily. Rotate or replace either of the squeegee blades if the leading edge is torn or worn half-way through the thickness of the blade.

The squeegee can be adjusted for leveling and deflection. The deflection of the squeegee blades should be checked daily, or when scrubbing a different type of floor. The leveling of the squeegee should be checked every 100 hours of machine operation.

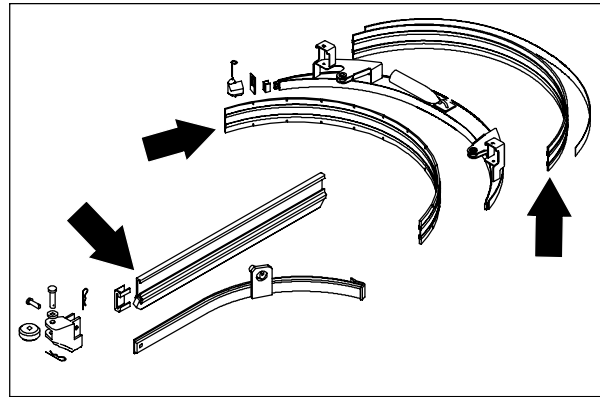

TO REPLACE SQUEEGEE PUSH-PULL CABLE

1. Start the engine, lower and side shift the scrub head, shut off the engine.

FOR SAFETY: Before Leaving Or Servicing Machine; Stop On Level Surface, Set Parking Brake, Turn Off Machine And Remove Key.

2. Raise the rear of machine using a hoist or floor jack.

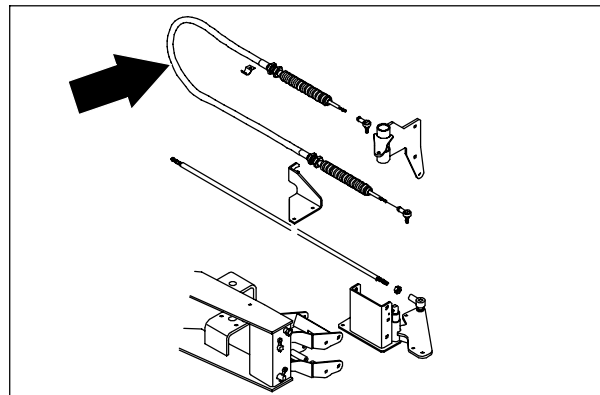

FOR SAFETY: Block machine tires before jacking machine up. Jack machine up at designated locations only. Block machine up with jack stands.

3. Remove the 0.31 in. nyloc nut holding the balljoint and push-pull cable to the LH side squeegee bracket.
4. Loosen the large hex nuts holding the cable to the cable bracket. Remove the cable from the bracket.

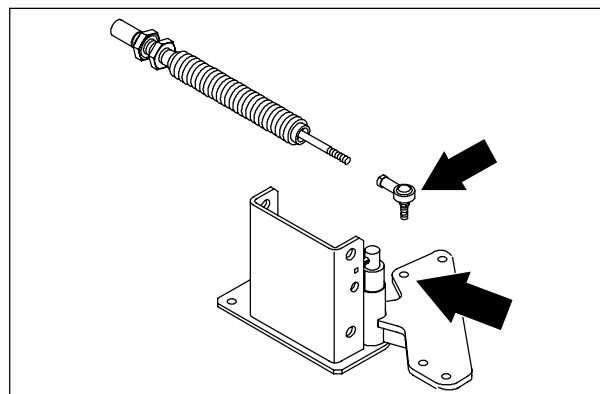

SCRUBBING

5. Remove the 0.31 in. nyloc nut holding the balljoint on the other end of the push-pull cable to the left hand rear squeegee pivot bracket.
6. Remove the M6 thread roller hex screw holding the clamp to the machine frame.
7. Remove the balljoints and jam nuts from the old cable and install on the new one. Run the jam nut and balljoint all the way on the threads.
8. Install the new cable in the machine. Make sure the cable is routed between the tie rod and scrub head frame.
9. Adjust the *rear* squeegee end of the cable at 8.25 inches from the center line of the balljoint to the edge of bracket with the cable in the retracted position.
10. Adjust the *side* squeegee end of cable at 8.25 inches from the center line of the balljoint to the edge of bracket with the cable in the retracted position. Firmly tighten all four large hex nuts.
11. Reinstall the cable clamp and M6 thread rolling hex screw to the bottom of the machine frame.
12. Reinstall the balljoints in the holes in both rear and side squeegee brackets. Tighten the 0.31 in. hex screw to 18 - 24 Nm (13 - 18 ft lb).
13. Lower machine and check for proper scrub head side shift operation.

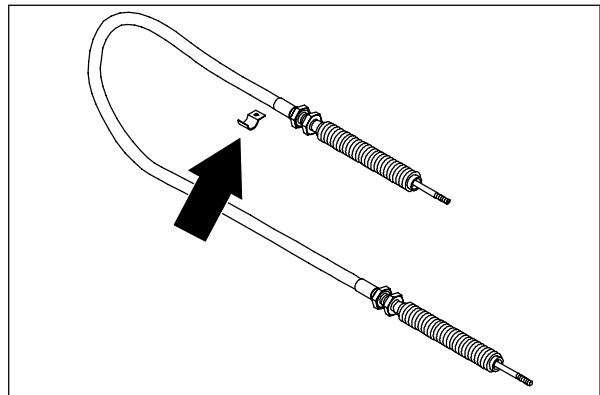
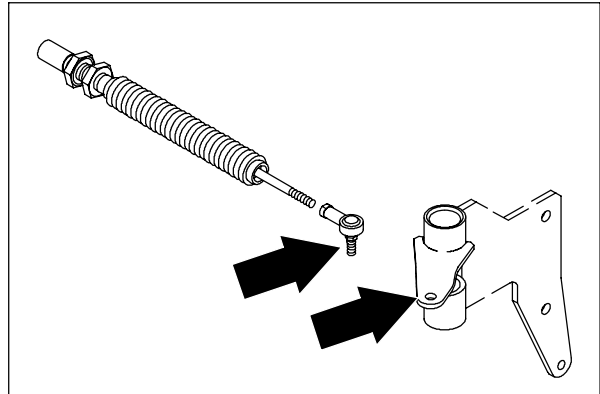
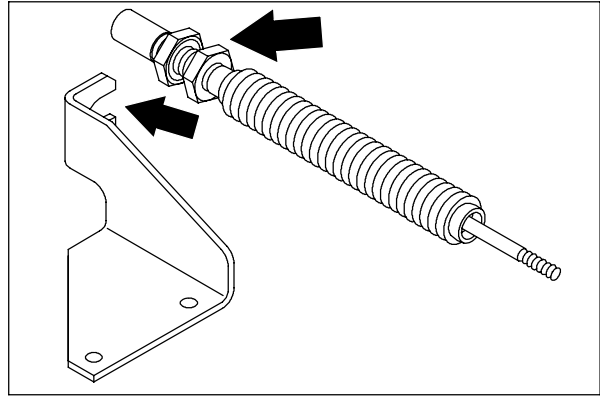

TO REPLACE SQUEEGEE LIFT CABLE

1. Start the engine, lower the rear squeegee, shut off the engine.

FOR SAFETY: Before Leaving Or Servicing Machine; Stop On Level Surface, Set Parking Brake, Turn Off Machine And Remove Key.

2. Raise the rear of machine using a hoist or floor jack.

FOR SAFETY: Block machine tires before jacking machine up. Jack machine up at designated locations only. Block machine up with jack stands.

3. Remove the M8 hex screw, nyloc nut, and spacer tube from the rear squeegee lift cable where it attaches at the center of the rear squeegee frame.

NOTE: The squeegee frame will drop down when the hex screw is removed.

4. Remove the clevis pin holding the lift cable to the upper cable bracket.

NOTE: When installing the new cable, make sure to route it around the plastic rollers in the same manner as it was removed.

5. Align the hole in the upper end of the new cable with the hole in the upper cable bracket. Reinstall the clevis pin and cotter pin.
6. Lift the squeegee assembly up until the hole in the lower end of the lift cable lines up with the hole in the squeegee frame. Reinstall the clevis pin and cotter pin.
7. Lower machine and check for proper rear squeegee lift cable operation.

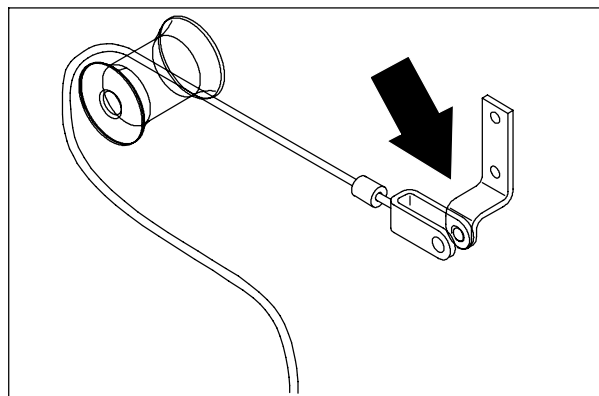
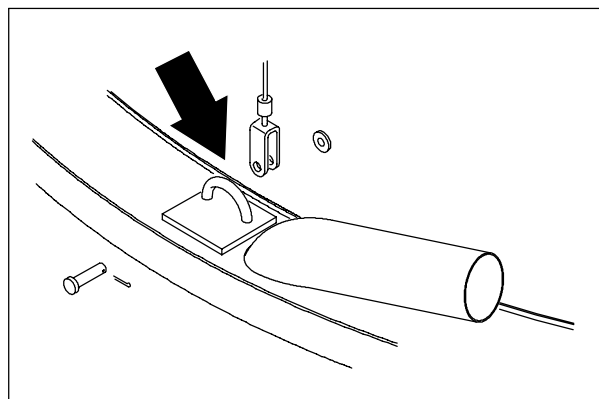
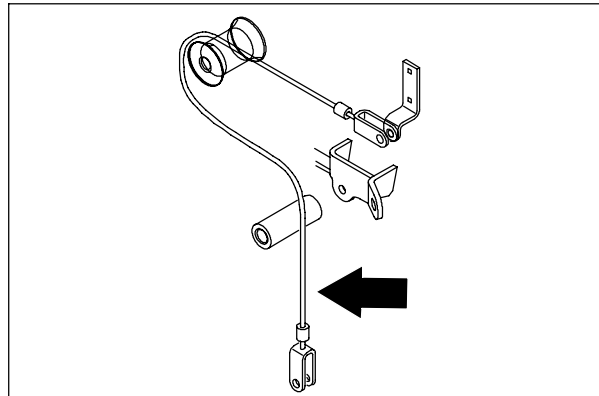

SCRUBBING

TO REMOVE REAR SQUEEGEE FRAME

1. Start the engine, lower the rear squeegee, shut off the engine.

FOR SAFETY: Before Leaving Or Servicing Machine; Stop On Level Surface, Set Parking Brake, Turn Off Machine And Remove Key.

2. Raise the rear of machine using a hoist or floor jack.

FOR SAFETY: Block machine tires before jacking machine up. Jack machine up at designated locations only. Block machine up with jack stands.

3. Remove the M8 hex screw, nyloc nut, and spacer tube from the rear squeegee lift cable where it attaches at the center of the rear squeegee frame.

NOTE: The squeegee frame will drop down when the hex screw is removed.

4. Remove the vacuum hose from the squeegee frame.

5. Remove the two tension springs connecting the squeegee upper link rods to the squeegee pivot brackets.

6. Remove the M10 hex screw, washers sleeve, thrust washers, and nyloc nut holding each of the four link rods to the squeegee pivot brackets.

7. The squeegee assembly can now be removed from the machine.

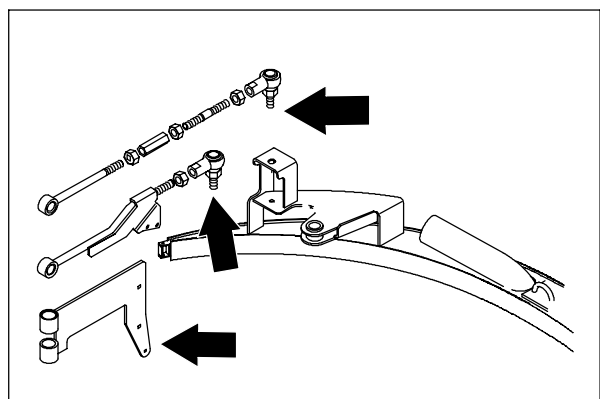
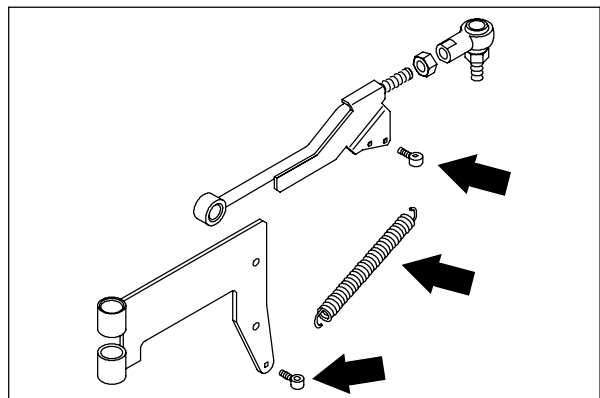
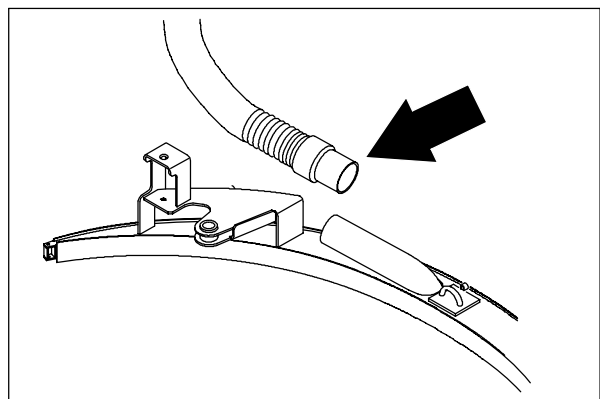
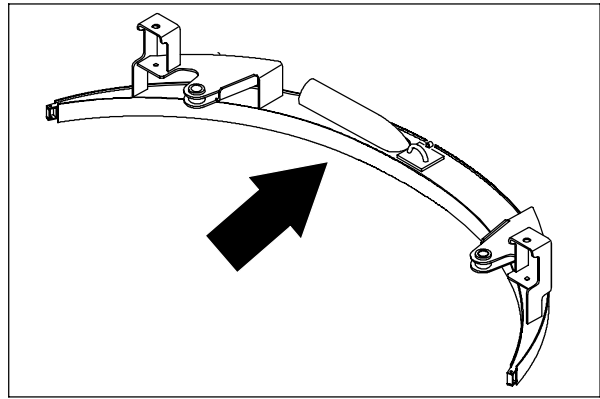

TO INSTALL REAR SQUEEGEE FRAME

1. Start the engine, lower the rear squeegee, shut off the engine.

FOR SAFETY: Before Leaving Or Servicing Machine; Stop On Level Surface, Set Parking Brake, Turn Off Machine And Remove Key.

2. Raise the rear of machine using a hoist or floor jack.

FOR SAFETY: Block machine tires before jacking machine up. Jack machine up at designated locations only. Block machine up with jack stands.

3. Position the squeegee assembly under the rear of the machine.

4. Align the holes in the end of squeegee link rods to the holes in the squeegee pivot brackets. Install the M10 hex screws, washers, sleeves, thrust washers, and nyloc nuts. Tighten to 37 - 48 Nm (25 - 53 ft lb).

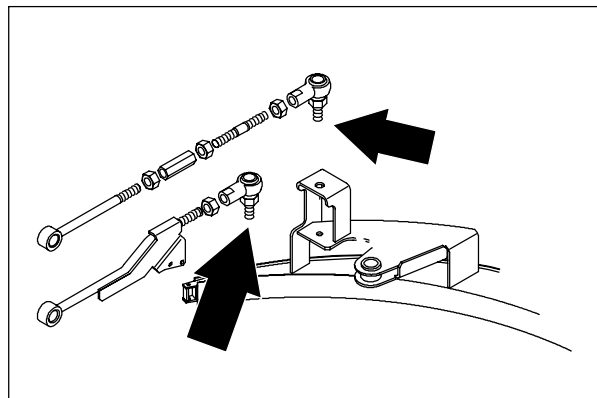

5. Reconnect the tension springs from the lower link rod to the squeegee pivot bracket.

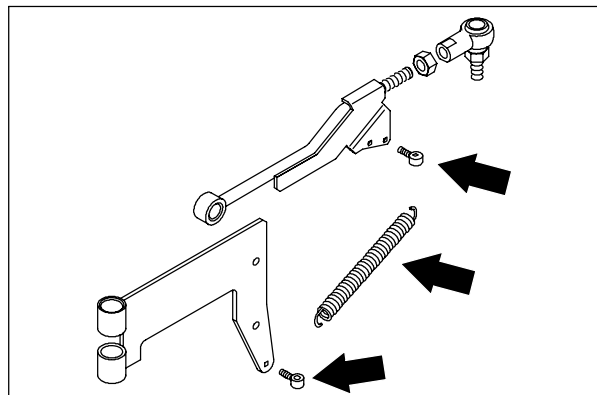

SCRUBBING

6. Lift the squeegee assembly up until the hole in the lower end of the lift cable lines up with the hole in the squeegee frame. Reinstall the M8 hex screw, nyloc nut, and spacer tube. Tighten to 18 - 24 Nm (13 - 18 ft lb).

7. Lower machine and check for proper rear squeegee operation.

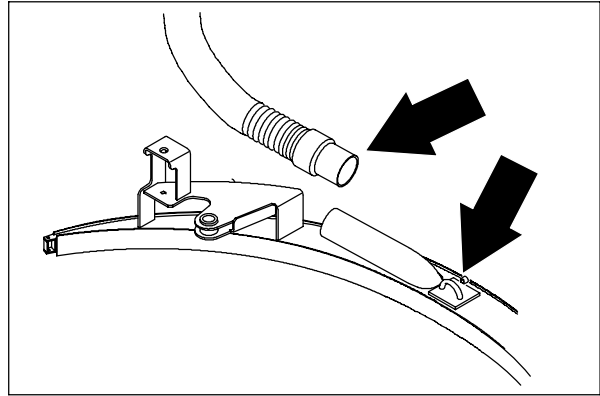

LEVELING THE REAR SQUEEGEE

Leveling of the squeegee assures even contact the length of the squeegee blade with the surface being scrubbed. Make sure this adjustment is done on an even, level floor.

1. Lower the squeegee and drive the machine forward.
2. Shut off the engine and set the machine parking brake.

FOR SAFETY: Before Leaving Or Servicing Machine; Stop On Level Surface, Set Parking Brake, Turn Off Machine And Remove Key.

3. Look at the deflection of the squeegee blade over the full length of the squeegee blade.
4. If the deflection is not the same over the full length of the blade, loosen the turnbuckle jam nuts.
5. Turn the turnbuckle clockwise, from the rear of the machine, to increase the deflection at the ends of the squeegee. Turn the turnbuckle counter-clockwise, from the rear of the machine, to decrease the deflection at the ends of the squeegee blade. Be sure to turn both turnbuckles the **same** number of turns.
6. Tighten the jam nuts.

NOTE: When tightening the turnbuckle jam nuts, make sure the rod ends are square with the squeegee frame, not tilted up.

7. Start the engine and drive the machine forward again to check the squeegee blade deflection.
8. Readjust the squeegee blade deflection if necessary.

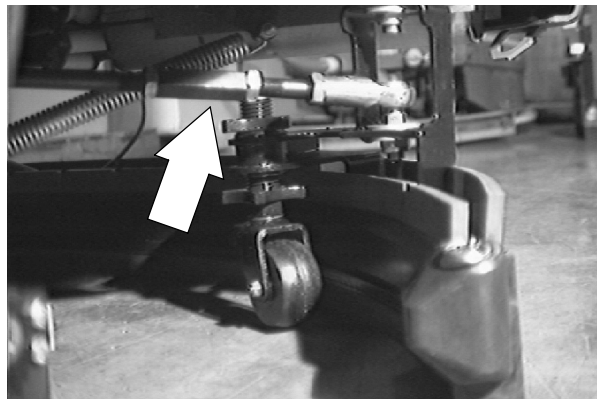

ADJUSTING REAR SQUEEGEE BLADE DEFLECTION

Deflection is the amount of curl the squeegee blade has when the machine moves forward with the squeegee lowered to the floor. The best deflection is when the squeegee wipes the floor just dry with a minimum amount of deflection.

1. Lower the squeegee and drive the machine forward.
2. Shut off the engine and set the machine parking brake.

FOR SAFETY: Before Leaving Or Servicing Machine; Stop On Level Surface, Set Parking Brake, Turn Off Machine And Remove Key.

3. Look at the deflection of the squeegee blade over the full length of the squeegee blade. The correct amount of deflection is 7 mm (0.25 in).
4. To adjust the amount of deflection, loosen the top knob on the two casters.
5. Turn the bottom knob clockwise to decrease the blade deflection. Turn the bottom knob counter-clockwise to increase the blade deflection. Be sure to turn both knobs the **same** number of turns. Tighten the top knobs on the casters.
6. Start the engine and drive the machine forward again to check the squeegee blade deflection. Readjust the squeegee blade deflection if necessary.
7. Raise the squeegee when finished.

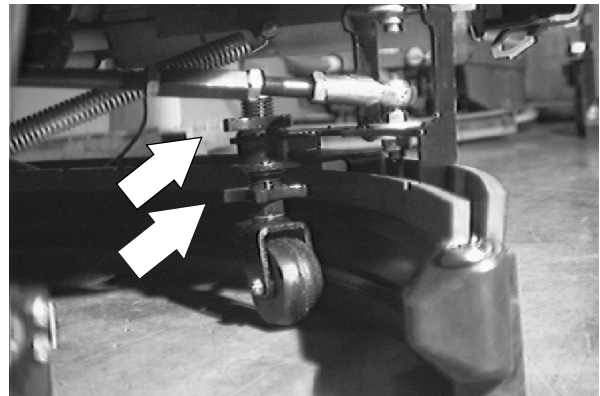

SQUEEGEE BLADES

REAR SQUEEGEE

The rear squeegee has two squeegee blades. Each blade has four wiping edges. To use them all, start with one wiping edge. To use the next wiping edge, rotate the blade end-for-end. To use the next wiping edge, rotate the top edges down, bottom edges up. To use the last edge, rotate the blade end-for-end.

Replace any worn or damaged squeegee blades.

REPLACING OR ROTATING REAR SQUEEGEE BLADES

1. Make sure the squeegee is raised off the floor.
2. Shut the engine off and set the parking brake.

FOR SAFETY: Before Leaving Or Servicing Machine; Stop On Level Surface, Set Parking Brake, Turn Off Machine And Remove Key.

3. Open the retaining band clamp and remove the squeegee blade.
4. Replace or rotate the squeegee blade to allow a new edge to face the front of the machine.
5. Place the squeegee blade over the pins of the squeegee frame.
6. Position the retaining band over the squeegee blade. Latch the retaining band clamp.
7. Adjust the squeegee blade leveling and deflection as stated in *LEVELING THE REAR SQUEEGEE* and *ADJUSTING REAR SQUEEGEE BLADE DEFLECTION*.

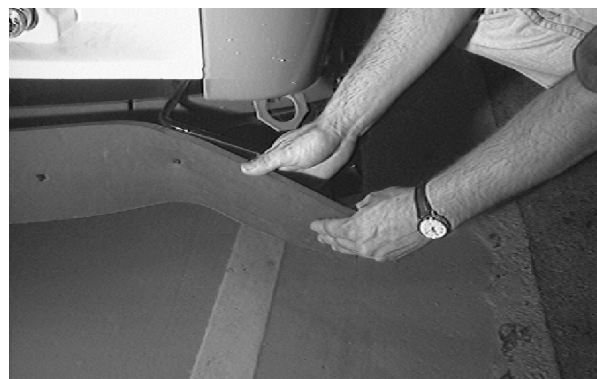
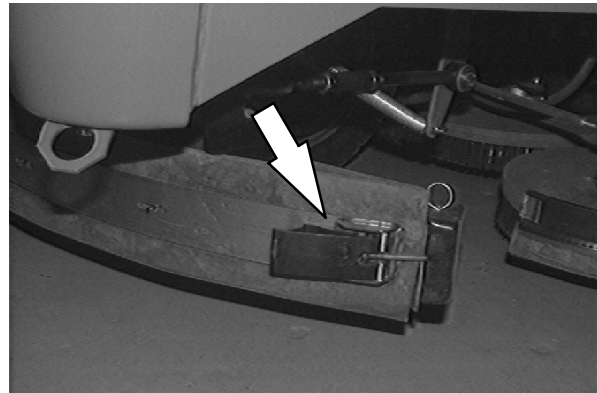

SCRUBBING

SIDE SQUEEGEES

The side squeegees control water spray and channel water into the path of the rear squeegee. Check the side squeegees for damage and wear daily. Replace the side squeegee blades whenever they become damaged or lose their shape or resilience. Replace the squeegee deflectors whenever they become worn.

REPLACING SIDE SQUEEGEE BLADES

1. Raise the scrub head.
2. Turn off the machine and set the machine parking brake.

FOR SAFETY: Before Leaving Or Servicing Machine; Stop On Level Surface, Set Parking Brake, Turn Off Machine And Remove Key.

3. Remove the cotter pin, clevis pin, deflector, and the retainer bracket from the front of the side squeegee.
4. Pull the squeegee blade off the front of the squeegee frame.
5. Slide the new squeegee blade onto the frame.

NOTE: Lubricating the squeegee frame where the squeegee makes contact will make for easier squeegee installation.

6. Replace the retainer bracket, deflector, clevis pin, and cotter pin.
7. Repeat for the side squeegee on the other side of the scrub head.

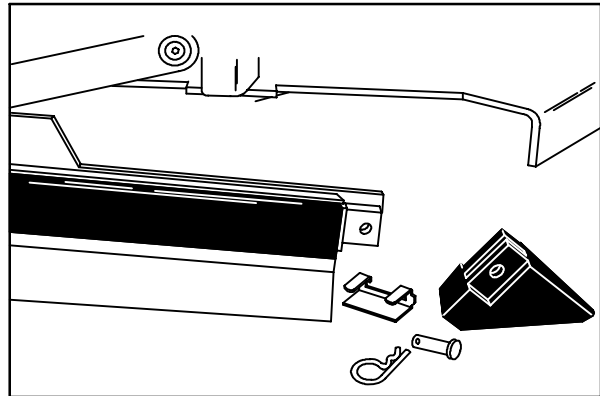

SCRUB VACUUM FAN

The scrub vacuum fan, when activated, creates a vacuum in the recovery tank. The recovery tank is sealed to the demister tank/engine cover when it is the down position. Water is pulled from the rear squeegee to the demister tank through a vacuum hose.

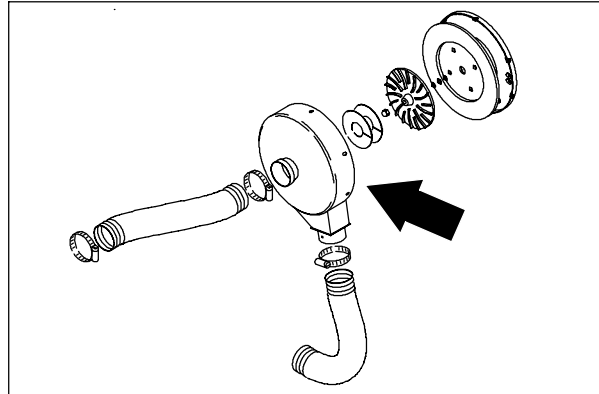

TO REMOVE SCRUB VACUUM FAN

FOR SAFETY: Before Leaving Or Servicing Machine; Stop On Level Surface, Set Parking Brake, Turn Off Machine And Remove Key.

1. Raise the engine cover.
2. Open the engine side door.
3. Loosen the hose clamp and remove the vacuum hose leading from recovery tank to the inlet tube of the scrub vacuum fan.
4. Loosen the hose clamp and remove the vacuum hose from the exhaust outlet of scrub vacuum fan.

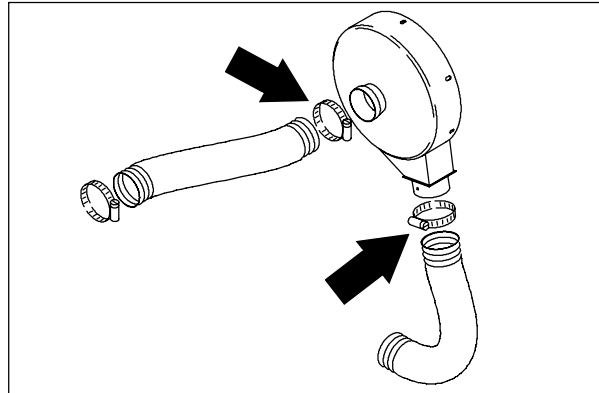

NOTE: Mark the hoses for proper re-assembly.

5. Remove and plug the hydraulic hoses connected to the scrub vacuum fan motor. Access to these hoses is between air cleaner and vacuum fan housing.

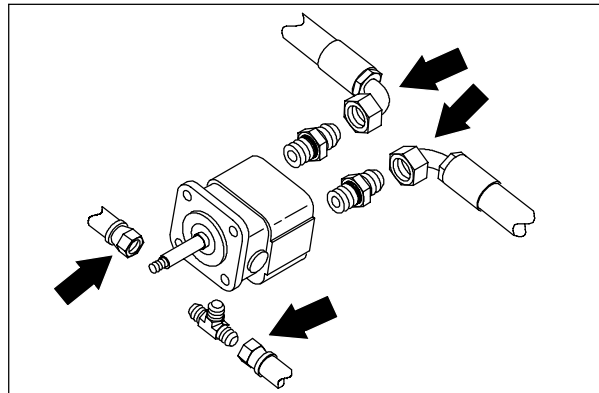

NOTE: Observe hydraulic cleanliness requirements when opening hydraulic lines.

6. Remove the three M10 hex screws, washers, and nyloc nuts holding the vacuum fan to mounting brackets.
7. Remove the vacuum fan assembly from the machine.

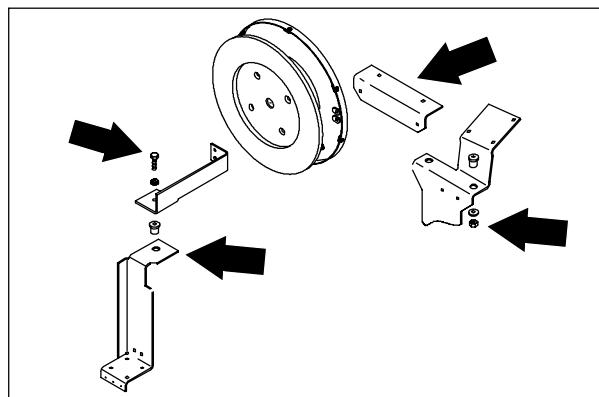

SCRUBBING

TO INSTALL SCRUB VACUUM FAN

FOR SAFETY: Before Leaving Or Servicing Machine; Stop On Level Surface, Set Parking Brake, Turn Off Machine And Remove Key.

1. Raise the engine cover.
2. Open the engine side door.
3. Position the vacuum fan assembly in the machine.
4. Align the three mounting holes in the vacuum fan housing with the three rubber isolators in the mounting brackets. Reinstall the three M10 hex screws, washers, and nyloc nuts. Tighten to 18 - 24 Nm (13 - 18 ft lb).
5. Reconnect the hydraulic hoses to the vacuum fan motor. See the hydraulic schematic in the HYDRAULIC section. Access to these hoses is between air cleaner and vacuum fan housing.
6. Reinstall the vacuum hose on the exhaust outlet of vacuum fan housing. Firmly tighten the hose clamp.
7. Reinstall the vacuum hose from recovery tank to the inlet tube on the vacuum fan housing. Firmly tighten the hose clamps.
8. Start engine and turn on the vacuum fan. Check for leaks and proper operation.

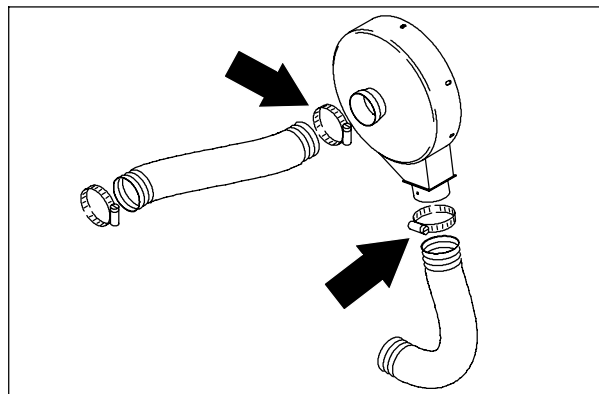
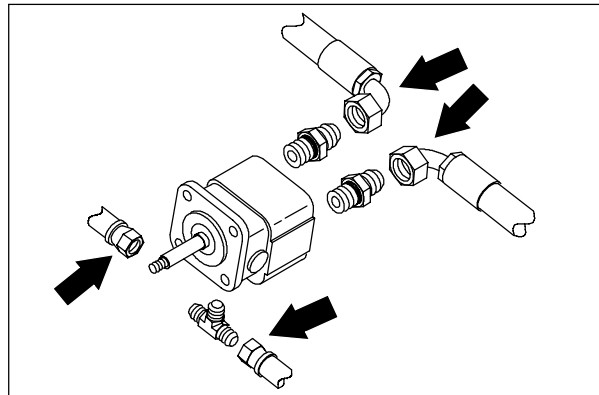
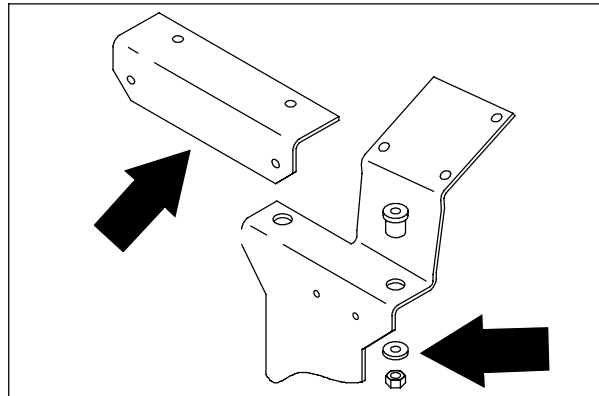
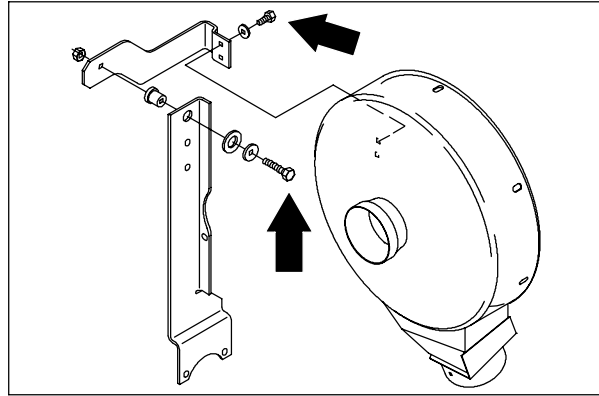

MACHINE TROUBLESHOOTING

| Problem | Cause | Remedy | |
|---|---|--|---------------------------|
| Trailing water – poor or no water pickup. | Worn rear squeegee blades. | Rotate or replace squeegee blades. | |
| | Rear squeegee out of adjustment. | Adjust rear squeegee. | |
| | Side squeegees raised. | Lower side squeegees. | |
| | Worn side squeegee blades. | Replace side squeegee blades. | |
| | Side squeegees out of adjustment. | Adjust side squeegees. | |
| | Tank cover not seated. | Reseat tank cover. | |
| | Tank cover seals worn. | Replace seals. | |
| | Too much solution flow to floor. | Reduce solution flow to floor. | |
| | Vacuum hose clogged. | Flush vacuum hoses. | |
| | Recovery tank full. | | Drain recovery tank. |
| | | | Check ES™ pump and filter |
| | Float stuck shutting off vacuum. | Clean float. | |
| | Debris caught on rear squeegee. | Remove debris. | |
| | Foam filling recovery tank. | Empty recovery tank; use less or change detergent. | |
| | Vacuum hose to rear squeegee disconnected or damaged. | Reconnect or replace vacuum hose. | |
| Vacuum fan to recovery tank hose damaged. | Replace hose. | | |
| Little or no solution flow to the floor. | Solution tank empty. | Fill solution tank. | |
| | Solution flow switch turned off. | Turn solution flow switch on. | |
| | Solution supply lines plugged. | Flush solution supply lines. | |
| | ES™ switch off. | Turn ES™ switch on. | |
| Poor scrubbing performance. | Debris caught on scrub brushes. | Remove debris. | |
| | Improper detergent or brushes used. | Check with TENNANT representative for advice. | |
| | Worn scrub brushes. | Replace scrub brushes. | |
| ES™ system does not fill solution tank. | Clogged solution pump or lines. | Flush ES™ system. | |
| | ES™ float stuck. | Clean floats of debris. | |
| | Clogged ES™ pump filter. | Clean filter. | |
| | Water levels too low in tanks. | Add water. | |

CONTENTS

| | Page | | Page |
|----------------------------------|------|-------------------------------|------|
| INTRODUCTION | 5-4 | SIDE PANEL OPERATING MODES .. | 5-56 |
| BATTERY | 5-4 | NORMAL MODE | 5-57 |
| TO REPLACE BATTERY | 5-5 | HAZARD LIGHTS: | 5-57 |
| INSTRUMENT PANEL | 5-6 | HEAD LIGHTS: | 5-57 |
| TO REPLACE MAIN INSTRUMENT | | FILTER SHAKER: | 5-57 |
| PANEL | 5-6 | HOPPER LIFT: | 5-57 |
| TO REPLACE AUXILIARY INSTRUMENT | | HOPPER LOWER: | 5-58 |
| PANEL | 5-7 | HOPPER DOOR: | 5-58 |
| TO DISASSEMBLE MAIN INSTRUMENT | | SIDE BRUSH: | 5-58 |
| PANEL | 5-8 | VACUUM FAN: | 5-58 |
| TO REASSEMBLE MAIN INSTRUMENT | | SWEEP 1 (NORMAL SWEEP): ... | 5-59 |
| PANEL | 5-9 | SWEEP 2 (LITTER SWEEP): ... | 5-60 |
| TO DISASSEMBLE AUXILIARY | | MANUAL MODE | 5-61 |
| INSTRUMENT PANEL | 5-10 | HAZARD LIGHT: | 5-61 |
| TO REASSEMBLE AUXILIARY | | HEAD LIGHT: | 5-61 |
| INSTRUMENT PANEL | 5-11 | FILTER SHAKER: | 5-61 |
| TO REPLACE MACHINE RELAY | 5-12 | HOPPER UP: | 5-61 |
| CIRCUIT BREAKERS | 5-13 | HOPPER DOWN: | 5-61 |
| TO REPLACE MACHINE CIRCUIT | | HOPPER DOOR: | 5-61 |
| BREAKER | 5-14 | SIDE BRUSH: | 5-62 |
| TO REPLACE GOVERNOR | | SWEEP FAN: | 5-62 |
| CONTROL BOX | 5-15 | SWEEP 1: | 5-62 |
| GAS/LP ELECTRICAL SCHEMATIC | 5-17 | SWEEP 2: | 5-62 |
| GAS/LP WIRE HARNESS GROUP | 5-20 | INPUT DISPLAY MODE: | 5-63 |
| DIESEL ELECTRICAL SCHEMATIC | 5-30 | BLINKING HAZARD LED: | 5-63 |
| DIESEL WIRE HARNESS GROUP | 5-34 | BLINKING SHAKER LED: | 5-63 |
| DIAGNOSTICS | 5-44 | BLINKING HOPPER DOOR LED: .. | 5-63 |
| FRONT PANEL OPERATING | | BLINKING SIDE BRUSH LED: ... | 5-63 |
| MODES | 5-45 | BLINKING HEAD LIGHT LED: ... | 5-63 |
| NORMAL MODE | 5-46 | ERROR DISPLAY MODE | 5-64 |
| EDGE SCRUB: | 5-46 | BLINKING SHAKER LED: | 5-64 |
| SQUEEGEE: | 5-46 | BLINKING HAZARD LED: | 5-64 |
| ENGINE SPEED: | 5-46 | BLINKING HEADLIGHT LED: ... | 5-64 |
| SCRUB: | 5-47 | BLINKING SIDE BRUSH LED: ... | 5-64 |
| DETERGENT: | 5-48 | BLINKING HOPPER DOOR LED: .. | 5-64 |
| ES: | 5-48 | BLINKING HOPPER UP LED: ... | 5-64 |
| OVER FLOW: | 5-48 | BLINKING HOPPER DOWN LED: .. | 5-64 |
| MANUAL MODE: | 5-49 | BLINKING SWEEP FAN LED: ... | 5-64 |
| ES: | 5-49 | BLINKING SWEEP 1 LED: | 5-64 |
| EDGE SCRUB BUTTON: | 5-49 | BLINKING SWEEP 2 LED: | 5-64 |
| SQUEEGEE BUTTON: | 5-49 | TROUBLESHOOTING | 5-66 |
| ENGINE BUTTON: | 5-49 | INSTRUMENT PANEL DOES NOT | |
| SCRUB BUTTON: | 5-49 | POWER UP (SCHEMATIC) | 5-67 |
| DETERGENT BUTTON: | 5-49 | INSTRUMENT PANEL DOES NOT | |
| INPUT DISPLAY MODE: | 5-50 | POWER UP (FLOW CHART) | 5-68 |
| ERROR DISPLAY MODE | 5-51 | SCRUB BRUSH WILL NOT TURN ON | |
| ES LED | 5-51 | AND/OR DOWN (SCHEMATIC) .. | 5-69 |
| EDGE SCRUB LED | 5-52 | SCRUB BRUSH WILL NOT TURN ON | |
| SQUEEGEE LED | 5-52 | AND/OR DOWN (FLOW CHART) . | 5-70 |
| SCRUB LED | 5-53 | SCRUB HEAD WILL NOT EXTEND | |
| DETERGENT LED | 5-53 | (SCHEMATIC) | 5-73 |
| PRESSURE ADJUST MODE .. | 5-54 | SCRUB HEAD WILL NOT EXTEND | |
| SCRUB BUTTON | 5-54 | (FLOW CHART) | 5-74 |
| RESET SCRUB PRESSURES .. | 5-55 | | |

| | Page | | Page |
|---|------|--|-------|
| SQUEEGEE AND VACUUM FAN NOT TURNING ON AND GOING DOWN (SCHEMATIC) | 5-75 | HOPPER DIFFERENTIAL PRESSURE LIGHT ALWAYS OFF (FLOW CHART) | 5-100 |
| SQUEEGEE AND VACUUM FAN NOT TURNING ON AND GOING DOWN (FLOW CHART) | 5-76 | HOPPER THERMAL SENTRY LIGHT ALWAYS ON (SCHEMATIC) | 5-101 |
| WATER VALVES NOT OPERATING (SCHEMATIC) | 5-79 | HOPPER THERMAL SENTRY LIGHT ALWAYS ON (FLOW CHART) .. | 5-102 |
| WATER VALVES NOT OPERATING (FLOW CHART) | 5-80 | HOPPER THERMAL SENTRY LIGHT ALWAYS OFF (SCHEMATIC) ... | 5-103 |
| RECOVERY TANK FULL LIGHT WILL NOT TURN ON OR OFF (SCHEMATIC) | 5-81 | HOPPER THERMAL SENTRY LIGHT ALWAYS OFF (FLOW CHART) | 5-104 |
| RECOVERY TANK FULL LIGHT WILL NOT TURN OFF (FLOW CHART) | 5-82 | HOPPER WILL NOT LIFT (SCHEMATIC) | 5-105 |
| RECOVERY TANK FULL LIGHT WILL NOT TURN ON (FLOW CHART) | 5-82 | HOPPER WILL NOT LIFT (FLOW CHART) | 5-106 |
| DETERGENT METERING PUMP IS NOT OPERATING (SCHEMATIC) | 5-83 | HOPPER WILL NOT LOWER (SCHEMATIC) | 5-107 |
| DETERGENT METERING PUMP IS NOT OPERATING (FLOW CHART) | 5-84 | HOPPER WILL NOT LOWER (FLOW CHART) | 5-108 |
| ES PUMP NOT WORKING (SCHEMATIC) | 5-85 | HOPPER DOOR WILL NOT CLOSE (SCHEMATIC) | 5-109 |
| ES PUMP NOT WORKING (FLOW CHART) | 5-86 | HOPPER DOOR WILL NOT CLOSE (FLOW CHART) | 5-110 |
| SWEEP BRUSH WILL NOT TURN ON AND LOWER WITH SWEEP 1 SELECTED (SCHEMATIC) ... | 5-87 | HOPPER DOOR WILL NOT OPEN (SCHEMATIC) | 5-111 |
| SWEEP BRUSH WILL NOT TURN ON AND LOWER WITH SWEEP 1 SELECTED (FLOW CHART) .. | 5-88 | HOPPER DOOR WILL NOT OPEN (FLOW CHART) | 5-112 |
| SWEEP BRUSH WILL NOT TURN ON AND LOWER WITH SWEEP 2 SELECTED SWEEP 1 WORKS (SCHEMATIC) | 5-89 | ENGINE COOLING FAN NOT OPERATING (SCHEMATIC) | 5-113 |
| SWEEP BRUSH WILL NOT TURN ON AND LOWER WITH SWEEP 2 SELECTED (FLOW CHART) .. | 5-90 | ENGINE COOLING FAN NOT OPERATING (FLOW CHART) ... | 5-114 |
| SWEEP SIDE BRUSH WILL NOT TURN ON AND LOWER (SCHEMATIC) . | 5-91 | ENGINE OIL PRESSURE WARNING LIGHT WILL NOT TURN ON OR OFF (SCHEMATIC) | 5-115 |
| SWEEP SIDE BRUSH WILL NOT TURN ON AND LOWER (FLOW CHART) 5-92 | 5-92 | ENGINE OIL PRESSURE WARNING LIGHT WILL NOT TURN OFF (FLOW CHART) | 5-116 |
| SWEEP VACUUM FAN WILL NOT TURN ON (SCHEMATIC) | 5-93 | ENGINE OIL PRESSURE WARNING LIGHT WILL NOT TURN ON (FLOW CHART) | 5-116 |
| SWEEP VACUUM FAN WILL NOT TURN ON (FLOW CHART) | 5-94 | ENGINE TEMPERATURE LIGHT WILL NOT TURN ON OR OFF (SCHEMATIC) | 5-117 |
| SHAKER SYSTEM WILL NOT TURN ON (SCHEMATIC) | 5-95 | ENGINE TEMPERATURE LIGHT WILL NOT TURN ON (FLOW CHART) | 5-118 |
| SHAKER SYSTEM WILL NOT TURN ON (FLOW CHART) | 5-96 | ENGINE TEMPERATURE LIGHT WILL NOT TURN OFF (FLOW CHART) | 5-118 |
| HOPPER DIFFERENTIAL PRESSURE LIGHT ALWAYS ON (SCHEMATIC) | 5-97 | ALTERNATOR / BATTERY WARNING LIGHT WILL NOT TURN ON (SCHEMATIC) | 5-119 |
| HOPPER DIFFERENTIAL PRESSURE SWITCH ALWAYS ON (FLOW CHART) | 5-98 | ALTERNATOR / BATTERY WARNING LIGHT WILL NOT TURN ON (FLOW CHART) | 5-120 |
| HOPPER DIFFERENTIAL PRESSURE SWITCH ALWAYS OFF (SCHEMATIC) | 5-99 | ALTERNATOR / BATTERY WARNING LIGHT STAYS ON WHEN ENGINE IS RUNNING (SCHEMATIC) ... | 5-121 |

| | Page |
|---|-------|
| ALTERNATOR / BATTERY WARNING LIGHT STAYS ON WHEN ENGINE IS RUNNING (FLOW CHART) . | 5-122 |
| FUEL GAUGE NOT OPERATING (GAS AND DIESEL) (SCHEMATIC) | 5-123 |
| FUEL GAUGE NOT OPERATING (GAS AND DIESEL) (FLOW CHART) | 5-124 |
| FUEL GAUGE (LPG) (SCHEMATIC) | 5-125 |
| FUEL GAUGE (LPG) (FLOW CHART) | 5-126 |
| HEAD LIGHTS WILL NOT TURN ON (SCHEMATIC) | 5-127 |
| HEAD LIGHTS WILL NOT TURN ON (FLOW CHART) | 5-128 |
| HAZARD LIGHT WILL NOT TURN ON (SCHEMATIC) | 5-129 |
| HAZARD LIGHT WILL NOT TURN ON (FLOW CHART) | 5-130 |
| REVERSE LIGHT OR ALARM DO NOT TURN ON (SCHEMATIC) | 5-131 |
| REVERSE LIGHT OR ALARM DO NOT TURN ON (FLOW CHART) | 5-132 |

INTRODUCTION

The machine's electrical system consists of the batteries, instrument panel, relays, and circuit breakers.

BATTERY

The battery used in the machine is a low maintenance battery. It has been constructed with special materials and has extra electrolyte to reduce or eliminate maintenance. Its design reduces electrolyte loss and contamination. Do not add water, remove the battery vent plugs, or check the battery specific gravity. For specific instructions, see the battery label.

Do not allow the battery to remain in discharged condition for any time. Do not operate the machine if the battery is in poor condition or discharged beyond 80%, specific gravity below 1.120.

Periodically clean the top surface of the batteries and the terminals, and check for loose connections. Use a strong solution of baking soda and water. Brush the solution sparingly over the battery tops, terminals, and cable clamps. Do not allow any baking soda solution to enter the batteries. Use a wire brush to clean the terminal posts and the cable connectors. After cleaning, apply a coating of clear battery post protectant to the terminals and the cable connectors. Keep the tops of the batteries clean and dry.

Keep all metallic objects off the top of the batteries, which may cause a short circuit. Replace any worn or damaged wires.

The electrolyte level in regular non-sealed batteries can be checked. The level must always be above the battery plates. Never add acid to the batteries, only distilled water. Keep the battery caps on the batteries always except when adding water or taking hydrometer readings.

**FOR SAFETY: When Servicing Machine,
Avoid Contact With Battery Acid.**

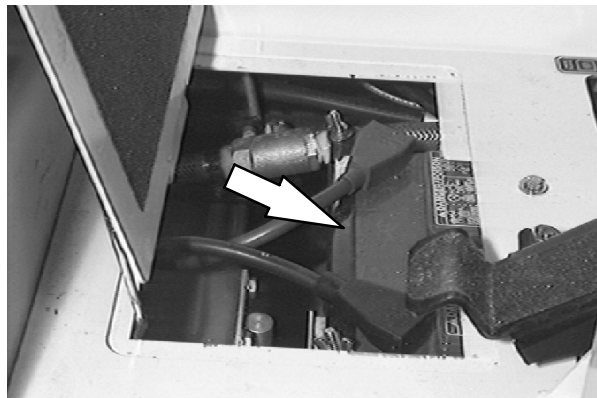

Using a hydrometer to measure the specific gravity is a way to determine the charge level and condition of the batteries. If one or more of the battery cells test lower than the other battery cells (0.050 or more), the cell is damaged, shorted, or is about to fail.

NOTE: Do not take readings immediately after adding distilled water. If the water and acid are not thoroughly mixed, the readings may not be accurate. Check the hydrometer readings against the following chart to determine the remaining battery charge level:

| SPECIFIC GRAVITY at 27° C (80° F) | BATTERY CHARGE |
|--------------------------------------|-------------------|
| 1.260 - 1.280 | 100% Charged |
| 1.230 - 1.250 | 75% Charged |
| 1.200 - 1.220 | 50% Charged |
| 1.170 - 1.190 | 25% Charged |
| 1.110 - 1.160 | Discharged |

NOTE: If the readings are taken when the battery electrolyte is any temperature other than 27° C (80° F), the reading must be temperature corrected. Add or subtract to the specific gravity reading 0.004, 4 points, for each 6° C (10° F) above or below 27° C (80° F).

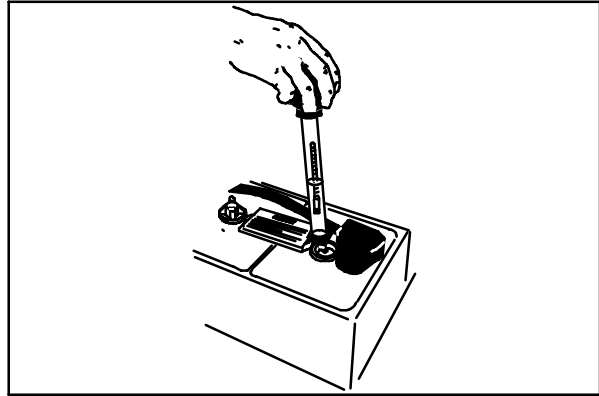

TO REPLACE BATTERY

FOR SAFETY: Before Leaving Or Servicing Machine; Stop On Level Surface, Set Parking Brake, Turn Off Machine And Remove Key.

1. Open the battery cover on the floor of the operators compartment.
2. Disconnect the negative cable first and then the positive battery cable.
3. Remove the battery hold down bracket from the machine.
4. Tilt the battery back and lift it out of the machine.
5. Clean the old cables and the posts on the new battery and install it in the machines battery tray.
6. Reinstall the battery hold down bracket.
7. Reconnect the positive cable and then the negative battery cable. Close the battery cover.

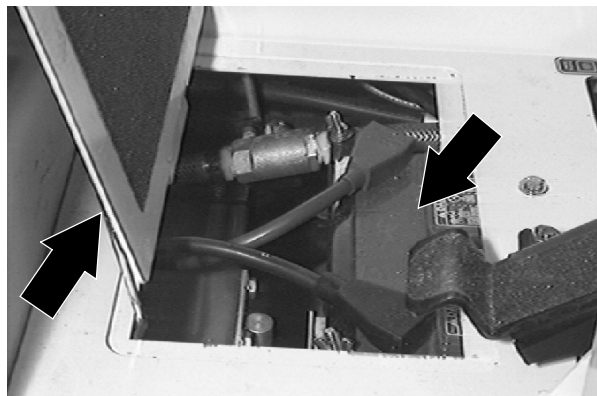

INSTRUMENT PANEL

The instrument panel consists of a circuit board, a touch panel, and a water/dust resistant plastic enclosure. The touch panel controls various machine functions, while its indicator lights keep the operator informed on machine performance.

TO REPLACE MAIN INSTRUMENT PANEL

FOR SAFETY: Before Leaving Or Servicing Machine; Stop On Level Surface, Set Parking Brake, Turn Off Machine And Remove Key.

1. Disconnect the battery cables from the machine.
2. Put the steering wheel in the lowest position.
3. Remove the four M8 hex head screws holding the dash panel to the machine.
4. Pull the dash panel back away from the machine.
5. Remove the four M5 pan head screws holding the instrument panel to the dash panel.
6. Loosen the allen head screw in center of wire harness plug. Unplug the harness.
7. Remove the instrument panel from the machine.
8. Install the new instrument panel back on the dash panel using the four M5 pan head screws and washers. Lightly hand tighten.
9. Push the harness plug back in the instrument panel plug.

NOTE: The slot in the panel plug must line up with the notch on the harness plug. Firmly hand tighten the allen head screw.

10. Position the dash panel back on the machine using the four M8 hex screws and washers. Tighten to 18 - 24 Nm (13 - 18 ft lb).
11. Reconnect the battery cables.
12. Start the machine and check for proper instrument panel operation.

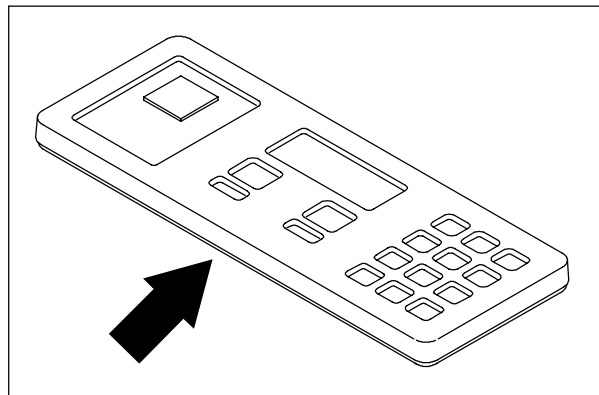
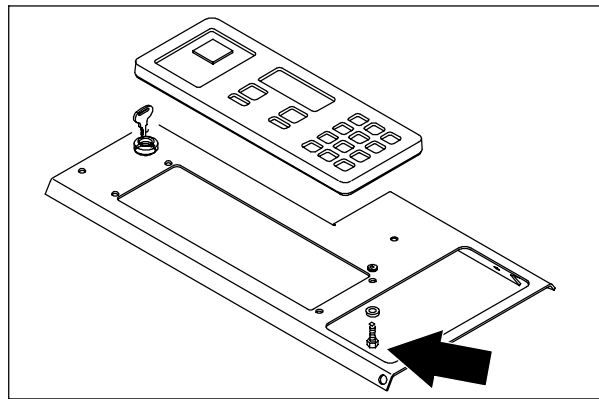
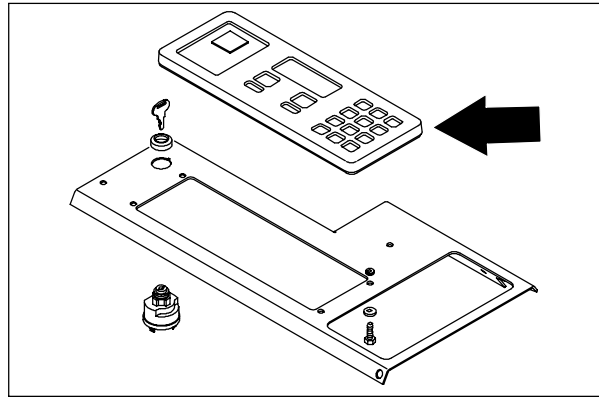

TO REPLACE AUXILIARY INSTRUMENT PANEL

FOR SAFETY: Before Leaving Or Servicing Machine; Stop On Level Surface, Set Parking Brake, Turn Off Machine And Remove Key.

1. Disconnect the battery cables from the machine.
2. Put the steering wheel in the lowest position.
3. Remove the four M8 hex head screws holding the dash panel to the machine.
4. Pull the dash panel back away from the machine.
5. Remove the two M4 pan head screws and bracket holding the top of the auxiliary instrument panel to the dash panel. Loosen the screws on the bottom of the panel.
6. Install the new auxiliary instrument panel back on the dash panel using the four M5 pan head screws and washers. Lightly hand tighten.
7. Push the harness plug back in the auxiliary instrument panel plug.

NOTE: The slot in the panel plug must line up with the notch on the harness plug. Firmly hand tighten the allen head screw.

8. Position the dash panel back on the machine using the four M8 hex screws and washers. Tighten to 18 - 24 Nm (13 - 18 ft lb).
9. Reconnect the battery cables.
10. Start the machine and check for proper auxiliary instrument panel operation.

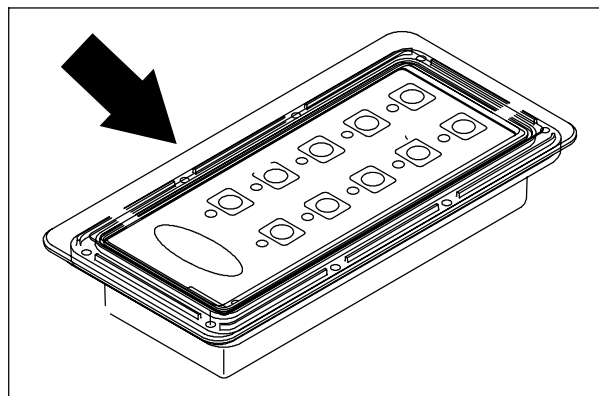
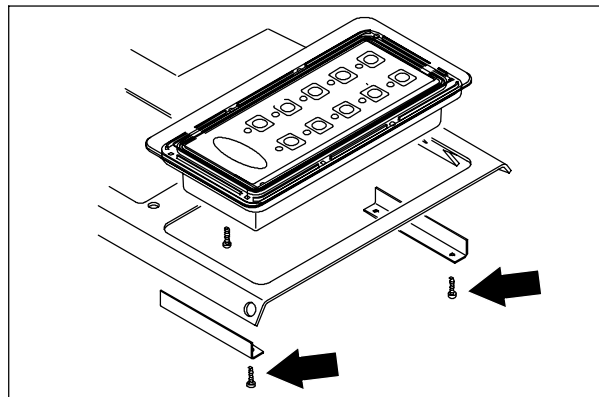
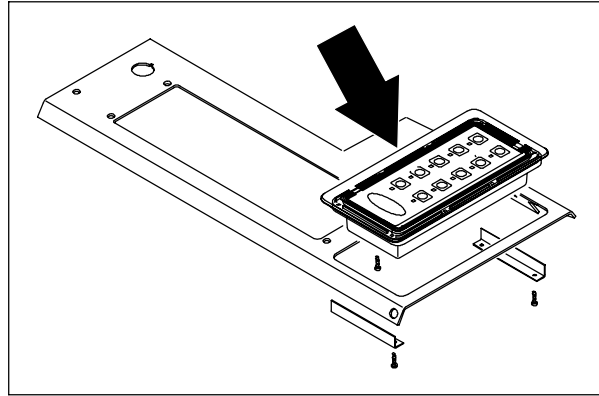

TO DISASSEMBLE MAIN INSTRUMENT PANEL

FOR SAFETY: Before Leaving Or Servicing Machine; Stop On Level Surface, Set Parking Brake, Turn Off Machine And Remove Key.

1. Remove the main instrument panel from the machine. See TO REPLACE MAIN INSTRUMENT PANEL instructions.
2. Place the main instrument panel face down and remove the twelve larger pan head screws holding it together.
3. The main instrument panel cases can now be separated.

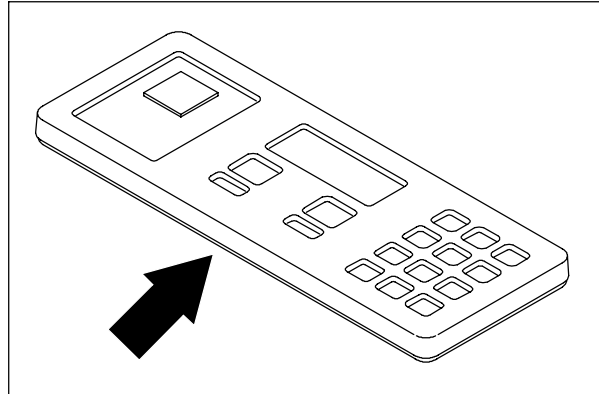

4. Remove the four smaller pan head screws to completely disassemble touch panel case.
5. Remove the case box from the circuit board and touch panel assembly.
6. The o-ring and connector gaskets can now be replaced in the case box if necessary.

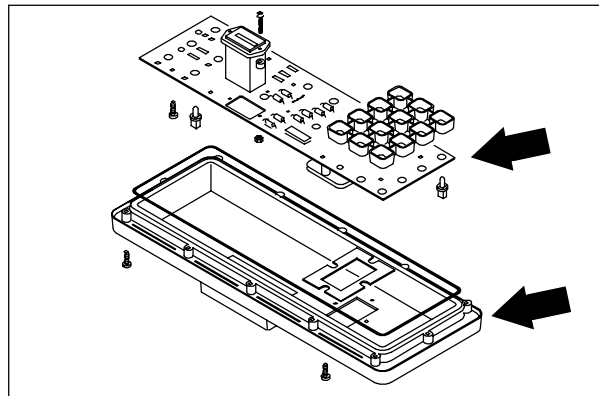

7. Remove the eight pan head screws and unplug the flat connector and ground strap to remove the touch panel from the circuit board.
8. Any burned-out lamps can now be changed by turning them 1/4 turn counterclockwise and lifting them out.
9. To replace the hour meter, unplug the two wires and remove the two pan head screws.

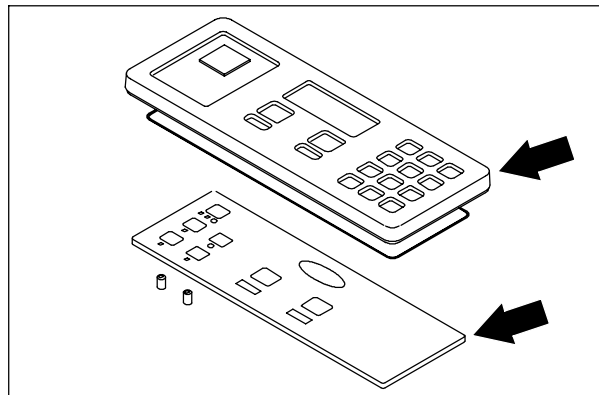

TO REASSEMBLE MAIN INSTRUMENT PANEL

FOR SAFETY: Before Leaving Or Servicing Machine; Stop On Level Surface, Set Parking Brake, Turn Off Machine And Remove Key.

1. Position the circuit board over the touch panel. Feed the flat connector from the panel through the slot in the board. Plug the flat connector in and reconnect the ground strap.
2. Reinstall the eight pan head screws and lightly hand tighten.
3. Turn the circuit board assembly over and place it back in the case box.
4. Reinstall the four smaller pan head screws in the center of the case box.
5. Reinstall the touch panel case to the outer case.
6. Reinstall the twelve pan head screws and lightly hand tighten.
7. The instrument panel is now ready to reinstall on the machine. See TO REPLACE MAIN INSTRUMENT PANEL instructions.

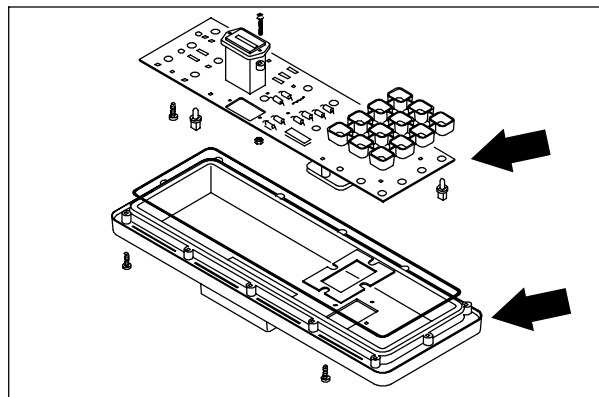
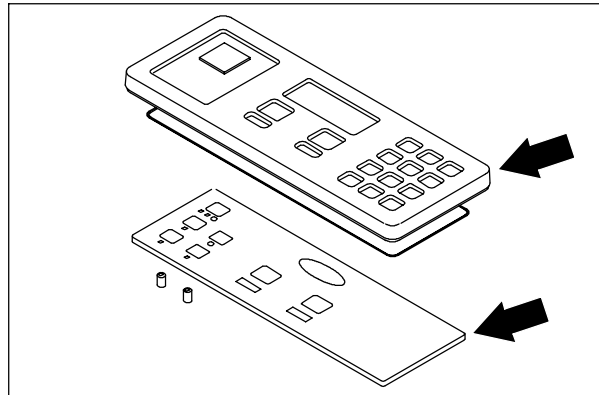
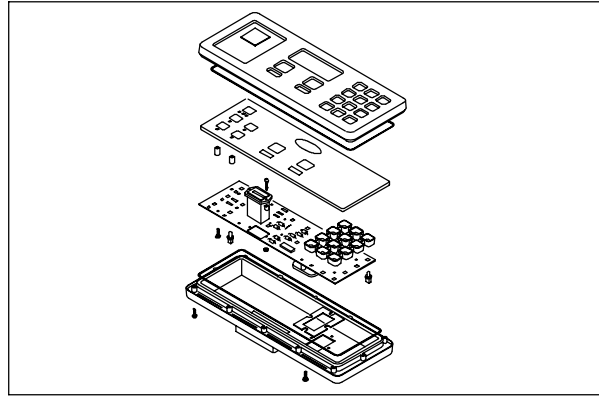

TO DISASSEMBLE AUXILIARY INSTRUMENT PANEL

FOR SAFETY: Before Leaving Or Servicing Machine; Stop On Level Surface, Set Parking Brake, Turn Off Machine And Remove Key.

1. Remove the auxiliary instrument panel from the machine. See TO REPLACE AUXILIARY INSTRUMENT PANEL instructions.
2. Place the auxiliary instrument panel face down and remove the eight pan head screws holding it together.
3. The auxiliary instrument panel cases can now be separated.
4. Remove the four smaller pan head screws to completely disassemble touch panel case.
5. Remove the case box from the circuit board and touch panel assembly.
6. The o-ring and connector gaskets can now be replaced in the case box if necessary.
7. Remove the four pan head screws and unplug the flat connector and ground strap to remove the touch panel from the circuit board.
8. Any burned-out lamps can now be changed by turning them 1/4 turn counterclockwise and lifting them out.
9. To replace the hour meter, unplug the two wires and remove the two pan head screws.

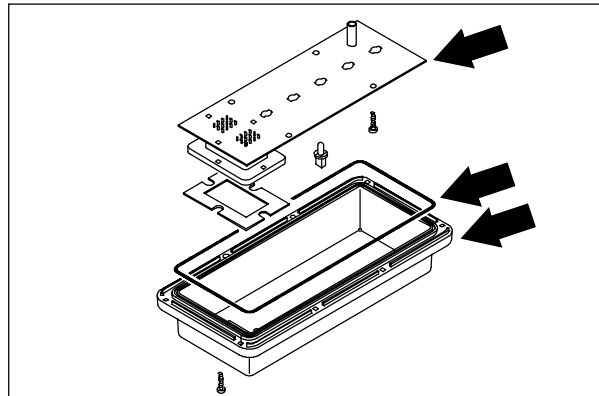
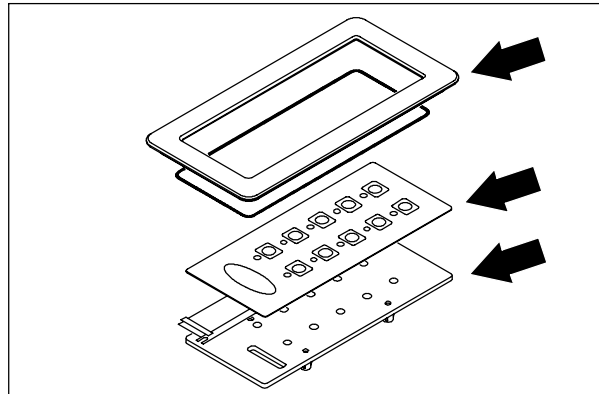
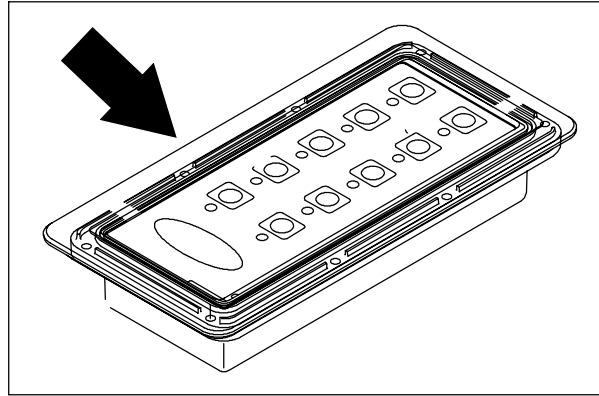

TO REASSEMBLE AUXILIARY INSTRUMENT PANEL

FOR SAFETY: Before Leaving Or Servicing Machine; Stop On Level Surface, Set Parking Brake, Turn Off Machine And Remove Key.

1. Position the circuit board over the touch panel. Feed the flat connector from the panel through the slot in the board. Plug the flat connector in and reconnect the ground strap.
2. Reinstall the four pan head screws and lightly hand tighten.
3. Turn the circuit board assembly over and place it back in the case box.
4. Reinstall the four smaller pan head screws in the center of the case box.
5. Reinstall the touch panel case to the outer case.
6. Reinstall the eight pan head screws and lightly hand tighten.
7. The instrument panel is now ready to reinstall on the machine. See TO REPLACE AUXILIARY INSTRUMENT PANEL instructions.

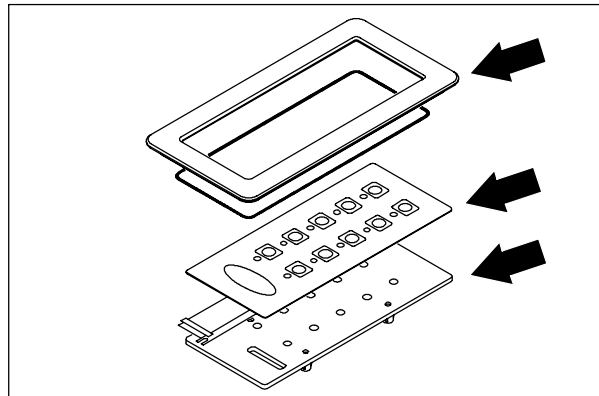
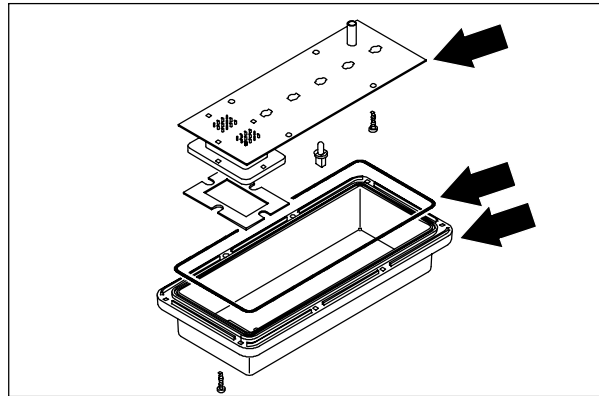
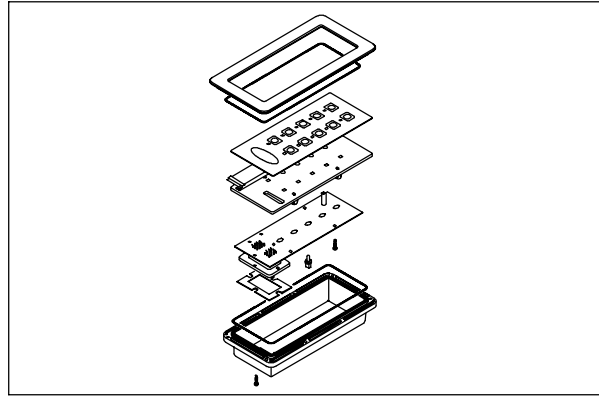

TO REPLACE MACHINE RELAY

FOR SAFETY: Before Leaving Or Servicing Machine; Stop On Level Surface, Set Parking Brake, Turn Off Machine And Remove Key.

1. Disconnect the battery cables from the machine.
2. Open the engine cover and side door.
3. Locate the problem relay on the back side of the operators compartment.
4. Remove the M6 nyloc nut from the top of the problem relay. Pull the relay off the stud.
5. Disconnect the relay from the main electrical harness. Discard the relay.
6. Plug the new relay in the electrical harness.
7. Position the new relay on the stud. Reinstall the M6 nyloc nut and firmly hand tighten.
8. Plug the new relay into the main harness. See schematic in the ELECTRICAL section.
9. Reconnect the battery cables and operate the machine. Check for proper operation.

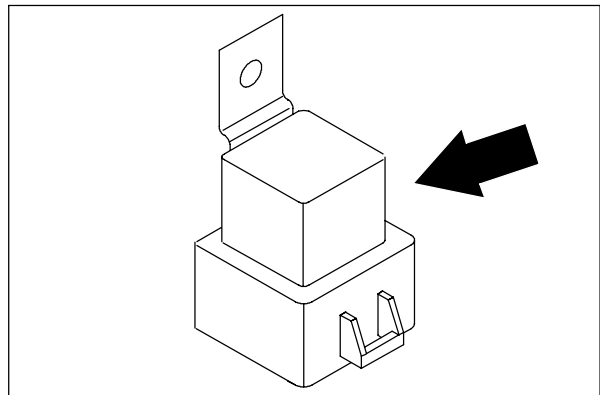
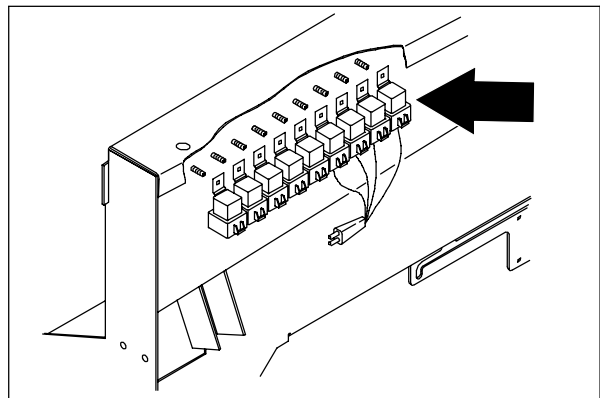
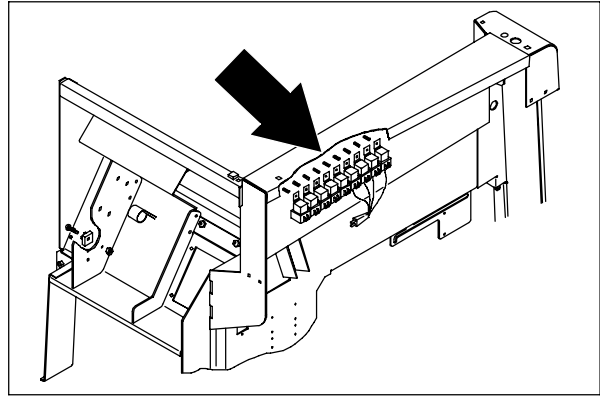

CIRCUIT BREAKERS

The circuit breakers are resettable electrical circuit protection devices. Their design stops the flow of current in the event of a circuit overload. Once a circuit breaker is tripped, it must be reset manually. Press the reset button after the breaker has cooled down.

If the overload that caused the circuit breaker to trip is still there, the circuit breaker will continue to stop current flow until the problem is corrected.

The circuit breakers are located in the operator compartment.

The chart lists the circuit breakers and the electrical components they protect.

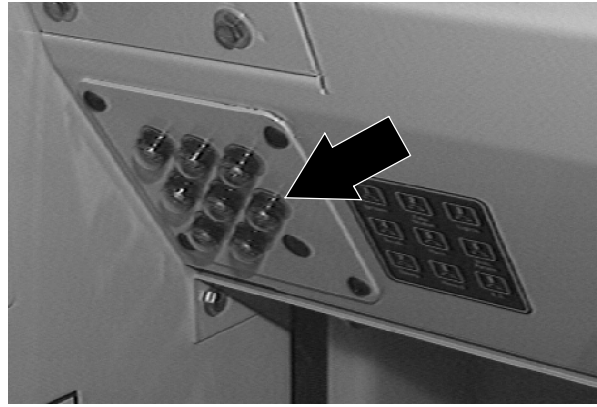

| Circuit Breaker | Rating | Circuit Protected |
|-----------------|--------|---------------------------|
| CB-1 | 15 A | Horn |
| CB-2 | 15 A | Ignition |
| CB-3 | 10 A | Instrument panel |
| CB-4 | 15 A | Scrubbing |
| CB-5 | 15 A | Filter shaker, vacuum fan |
| CB-6 | 15 A | Operating lights |
| CB-7 | 15 A | ES™ |
| CB-8 | 15 A | Sweeping |
| CB-9 | 15 A | Solenoid valve |

TO REPLACE MACHINE CIRCUIT BREAKER

FOR SAFETY: Before Leaving Or Servicing Machine; Stop On Level Surface, Set Parking Brake, Turn Off Machine And Remove Key.

1. Disconnect the battery cables from the machine.
2. Go in the operators compartment and remove the four black plastic rivets holding the circuit breaker mount bracket to the dash panel. Retain the rivets.
3. Pull the circuit breaker mount bracket back to expose the circuit breakers.
4. Locate the problem circuit breaker and disconnect it from the main electrical harness.
5. Remove and retain the rubber boot from the front of the circuit breaker.
6. Remove and discard the metal retaining ring from the back of the circuit breaker.
7. Push the old circuit breaker out of the mount panel. Discard the circuit breaker.
8. Position the new circuit breaker in the mount panel.

NOTE: The hole in the mount panel is "D" shaped. Make sure to install the new circuit breaker in the correct orientation.

9. Install the new retaining ring on the new circuit breaker. Push the retaining ring all the way down the circuit breaker.
10. Reconnect the circuit breaker to the main electrical harness. See schematic in the ELECTRICAL section.
11. Reinstall the rubber boot on the front of the new circuit breaker.
12. Position the circuit breaker mount panel to the dash panel. Reinstall the four plastic rivets.
13. Reconnect the battery cables and operate the machine. Check for proper operation.

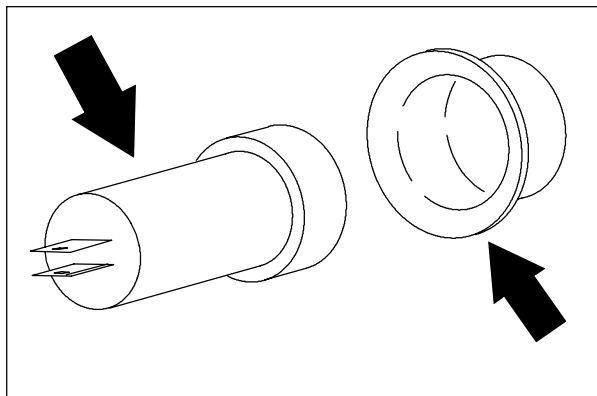
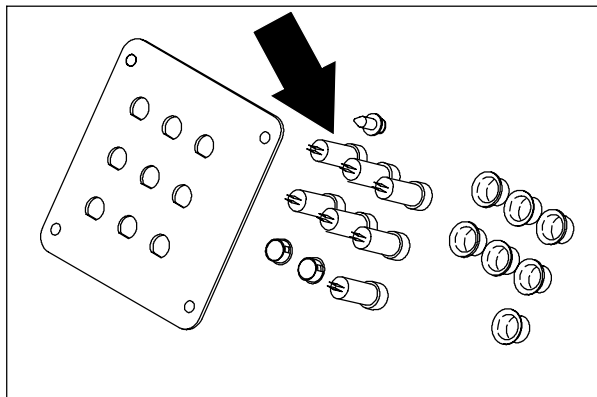
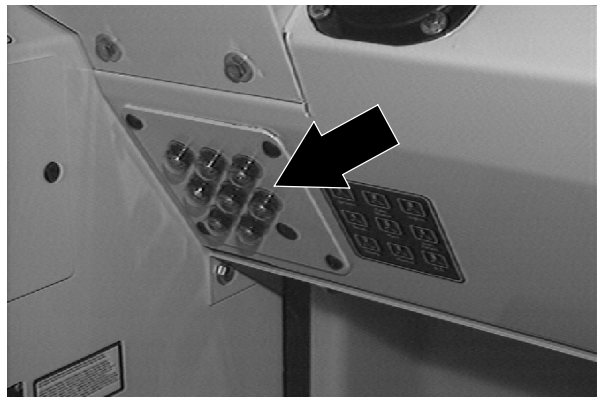

TO REPLACE GOVERNOR CONTROL BOX

FOR SAFETY: Before Leaving Or Servicing Machine; Stop On Level Surface, Set Parking Brake, Turn Off Machine And Remove Key.

1. Disconnect the battery cables from the machine.
2. Open the engine cover and side door.
3. Locate the governor control box on the back side of the operators compartment.
4. Remove the two nuts holding the control box to the control panel.
5. Pull the control box off the studs and disconnect it from the main electrical harness. Remove the control box from the machine.

NOTE: You may have to cut a few plastic ties holding the control box harness to the main harness.

6. Position the new control box in the engine compartment.
7. Connect the new control box to the main electrical harness. See schematic in the ELECTRICAL section.
8. Position the control box on the studs and reinstall the two nuts. Lightly hand tighten.

NOTE: Reinstall any plastic ties that were removed earlier.

9. Reconnect the battery cables and operate the machine. Check for proper operation.

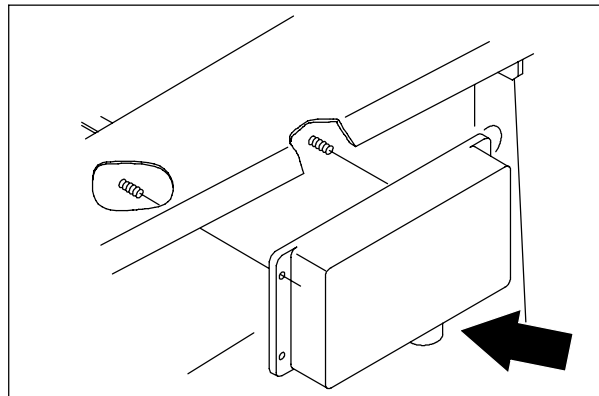
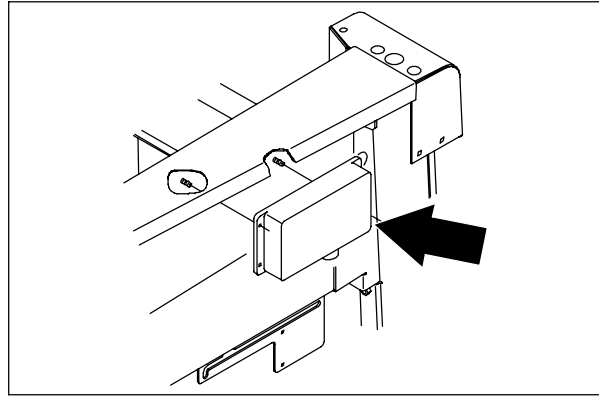

GAS/LP ELECTRICAL SCHEMATIC

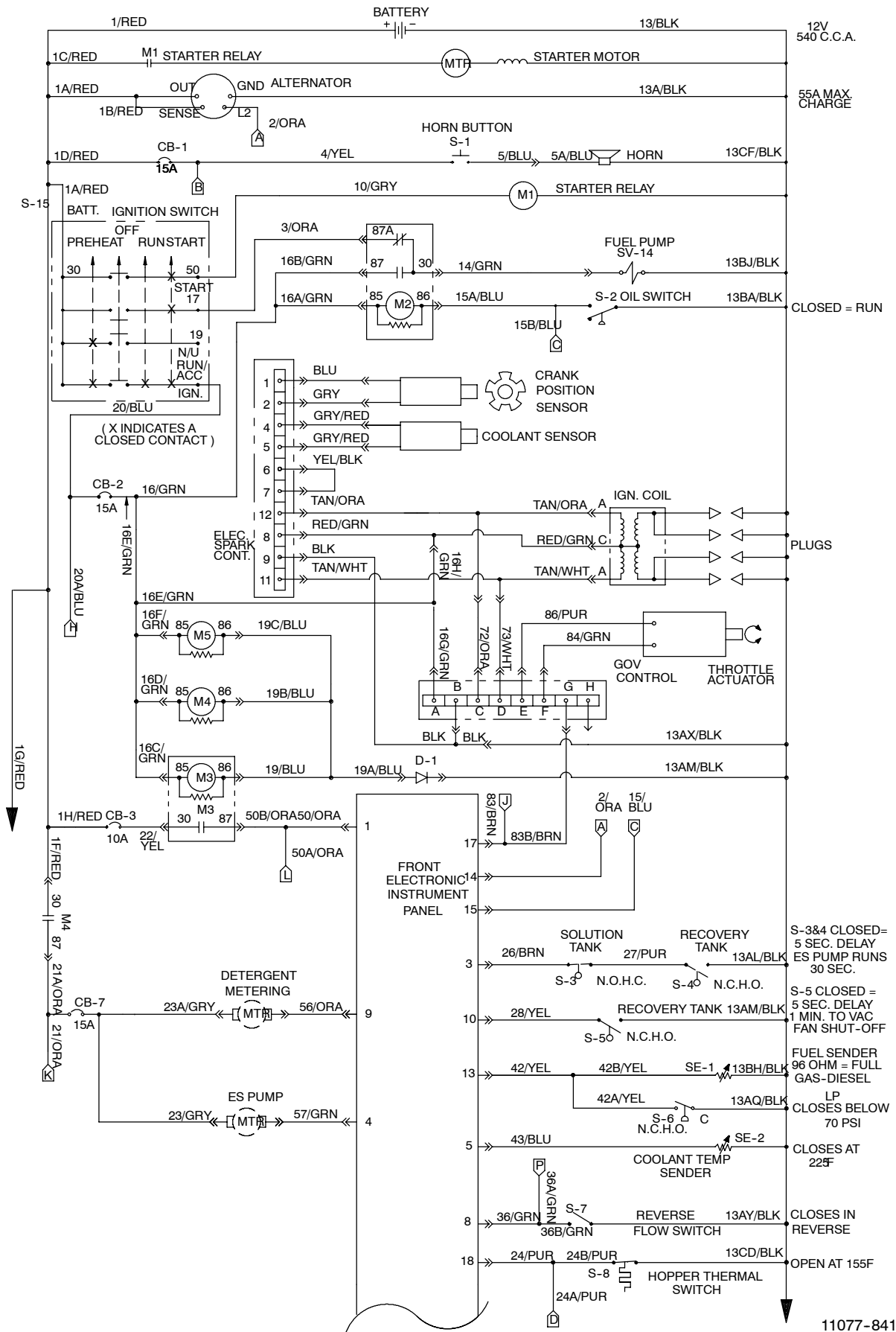

11077-8410 G, LP

GAS/LP ELECTRICAL SCHEMATIC

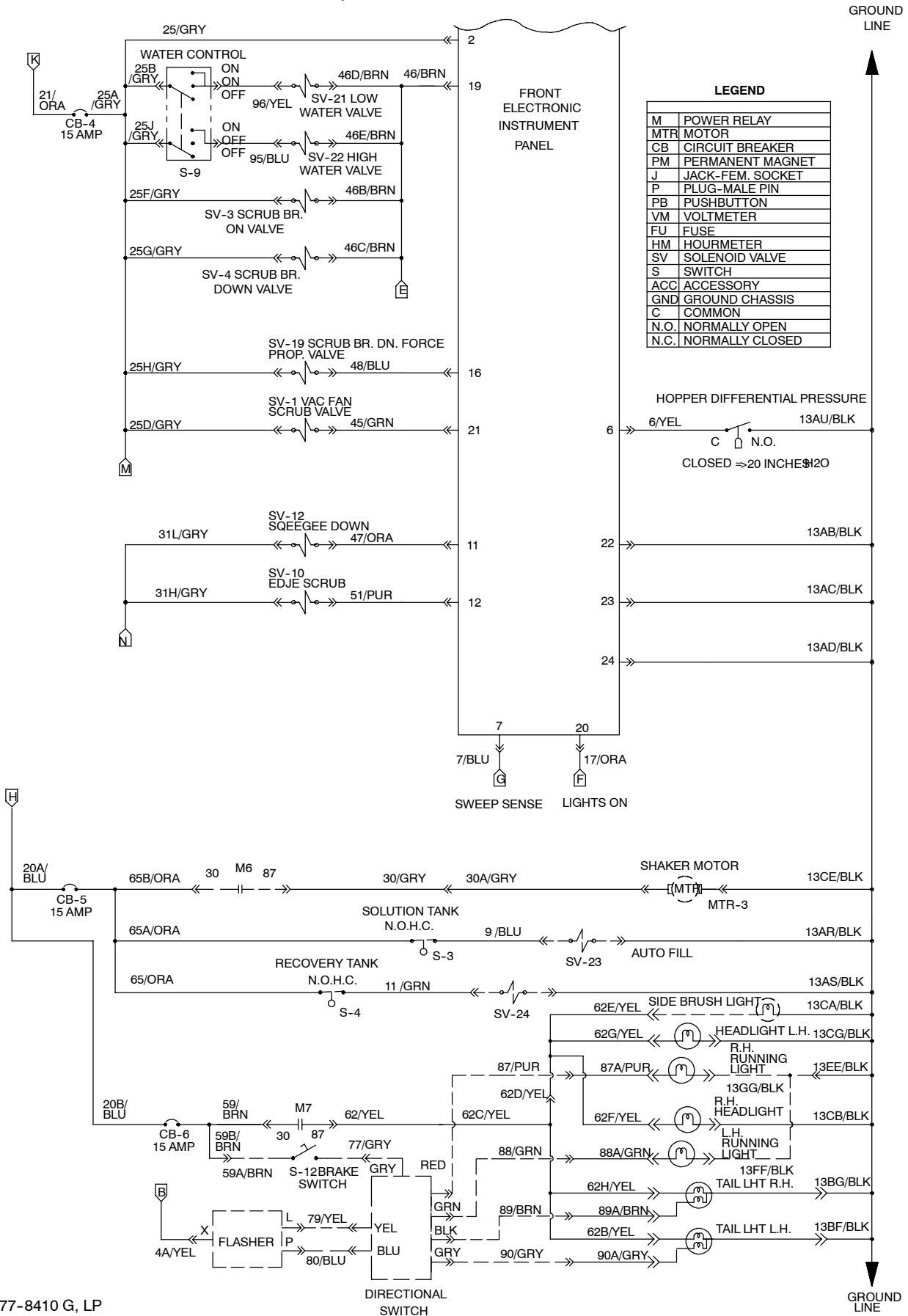

LEGEND

| | |
|------|------------------|
| M | POWER RELAY |
| MTR | MOTOR |
| CB | CIRCUIT BREAKER |
| PM | PERMANENT MAGNET |
| J | JACK-FEM. SOCKET |
| P | PLUG-MALE PIN |
| PB | PUSHBUTTON |
| VM | VOLTMETER |
| FU | FUSE |
| HM | HOURLMETER |
| SV | SOLENOID VALVE |
| S | SWITCH |
| ACC | ACCESSORY |
| GND | GROUND CHASSIS |
| C | COMMON |
| N.O. | NORMALLY OPEN |
| N.C. | NORMALLY CLOSED |

HOPPER DIFFERENTIAL PRESSURE
 6/YEL C N.O. 13AU/BLK
 CLOSED ⇒ 20 INCHES ± 20

GAS/LP ELECTRICAL SCHEMATIC

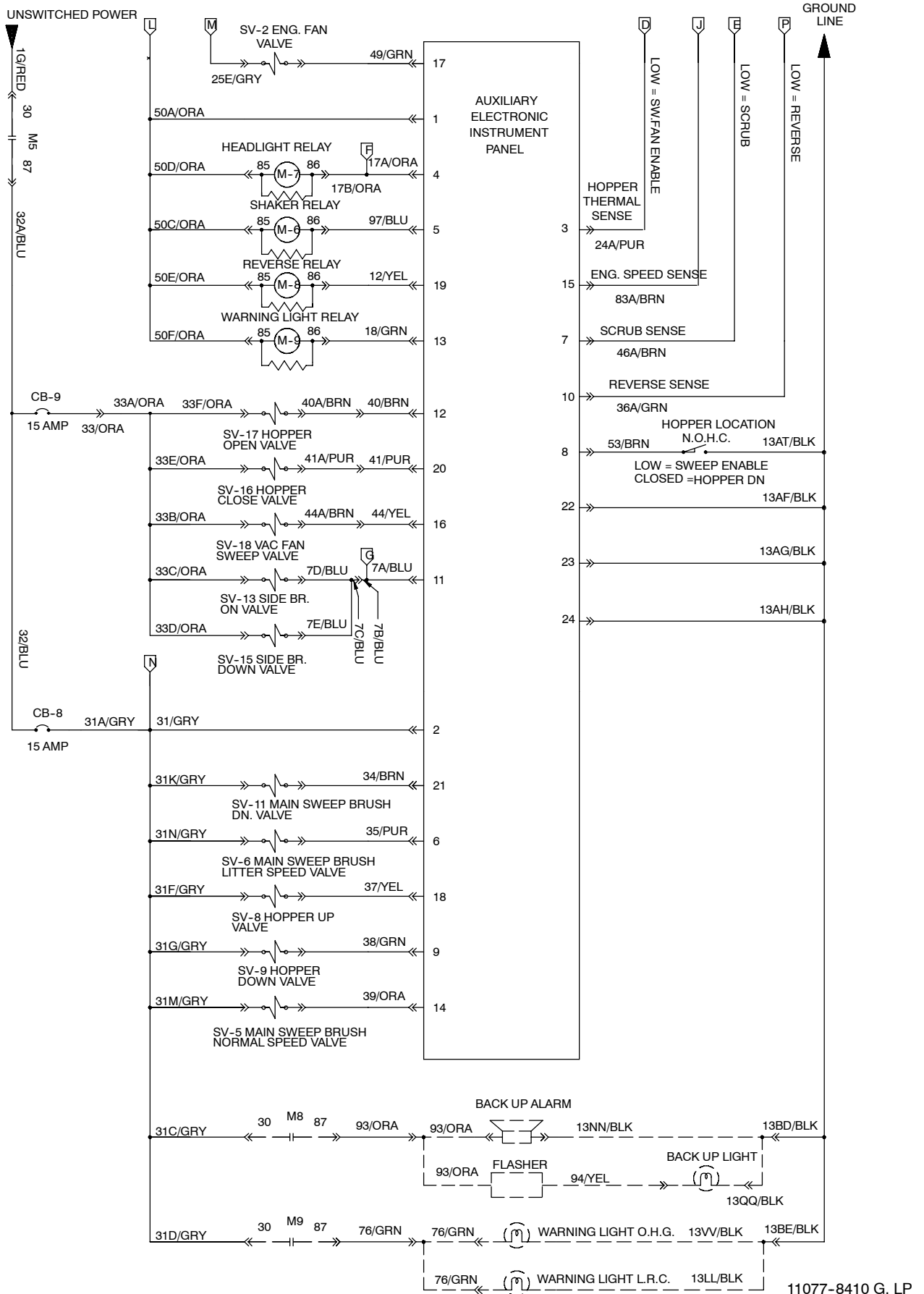

GAS/LP WIRE HARNESS GROUP

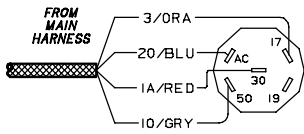
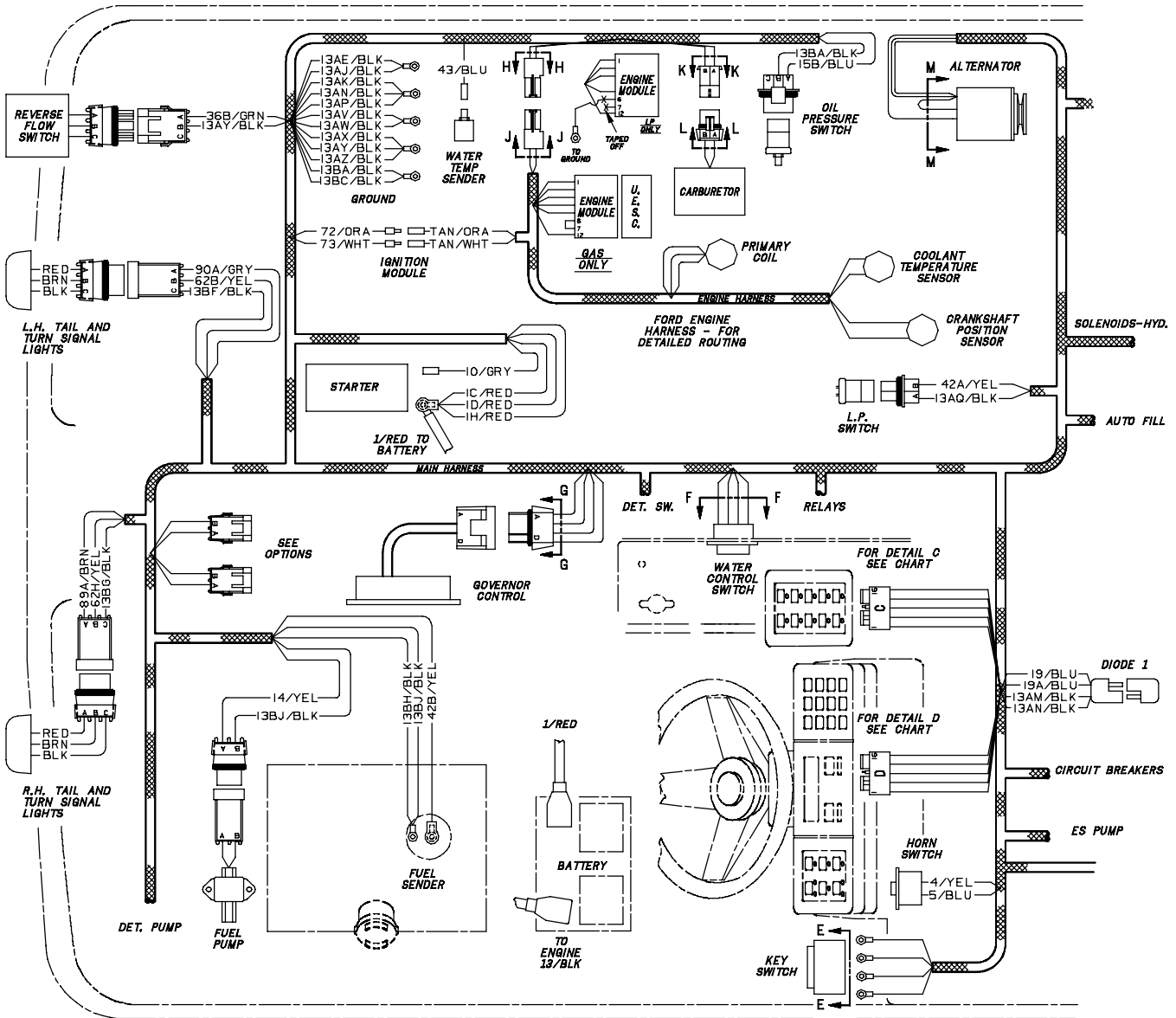

VIEW E-E
KEY SWITCH

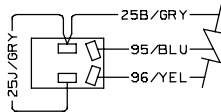

VIEW F-F
WATER CONTROL SWITCH

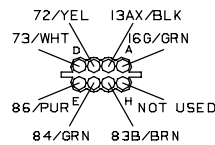

VIEW G-G
GOVERNOR CONTROL

GAS/LP WIRE HARNESS GROUP

| | | | | | | | | | | |
|-----|-----|-----|-----|-----|-----|------|-----|-----|-----|------|
| E | 7B | 24B | 30 | 33 | 40 | 13AW | 4H | 44 | 62C | 13AV |
| BLU | YEL | PUR | GRY | ORA | BRN | BLK | PUR | YEL | ORA | BLK |
| A | B | C | D | E | F | G | A | B | C | D |



MAIN HARNESS VIEW A-A



CONNECTORS ARE ROTATED 90° FOR VIEWING



HOPPER HARNESS VIEW B-B



| | | | | | | | | | | |
|-----|-----|-----|-----|-----|-----|------|-----|-----|-----|------|
| 13A | 7C | 24C | 30A | 33A | 40A | 13CC | 41A | 44A | 62D | 13CA |
| BLU | YEL | PUR | GRY | ORA | BRN | BLK | PUR | YEL | ORA | BLK |
| A | B | C | D | E | F | G | A | B | C | D |

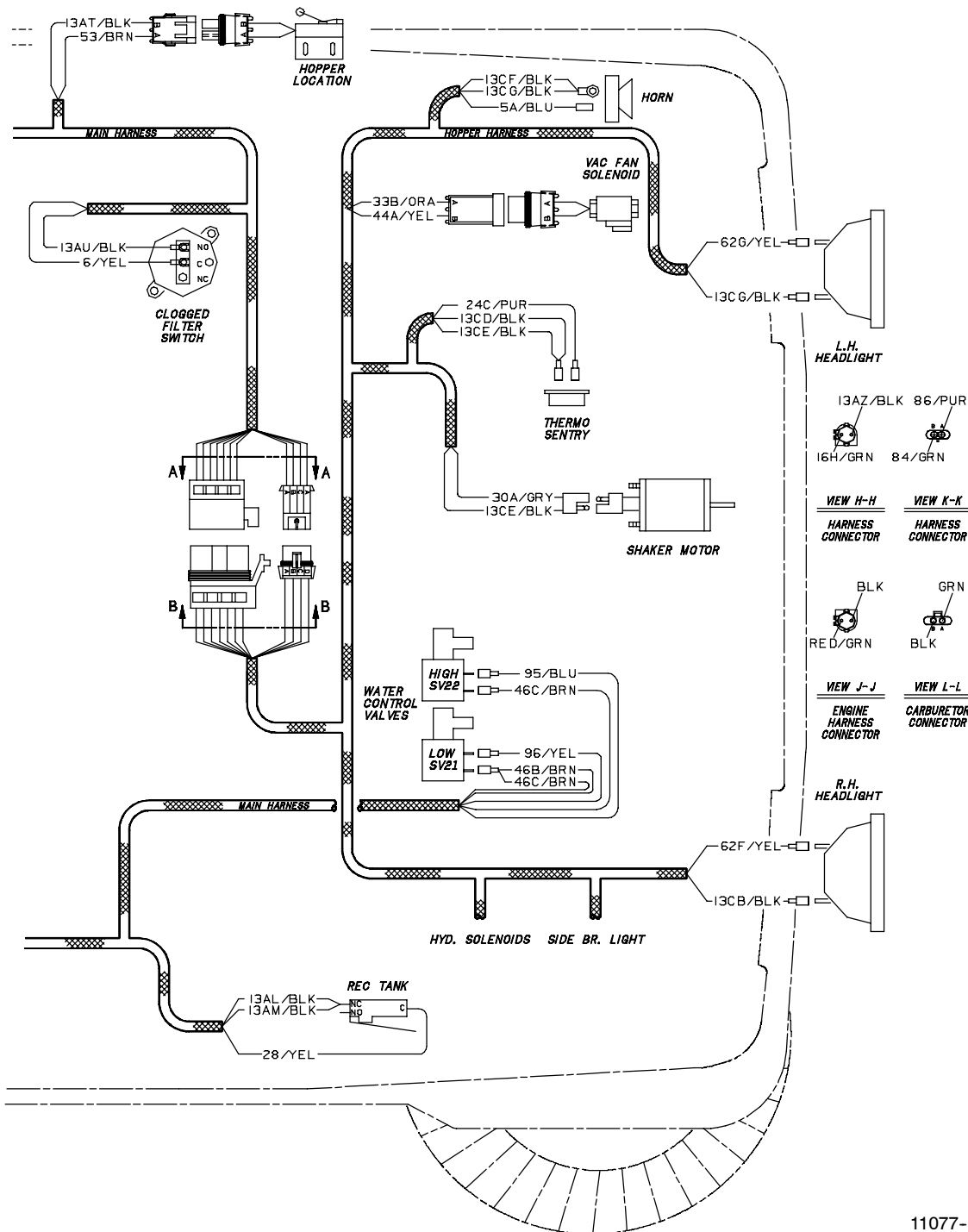

L.H. HEADLIGHT

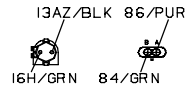

VIEW H-H HARNESS CONNECTOR VIEW K-K HARNESS CONNECTOR



VIEW J-J ENGINE HARNESS CONNECTOR VIEW L-L CARBURETOR CONNECTOR

R.H. HEADLIGHT

11077-8410 G, LP

GAS/LP WIRE HARNESS GROUP

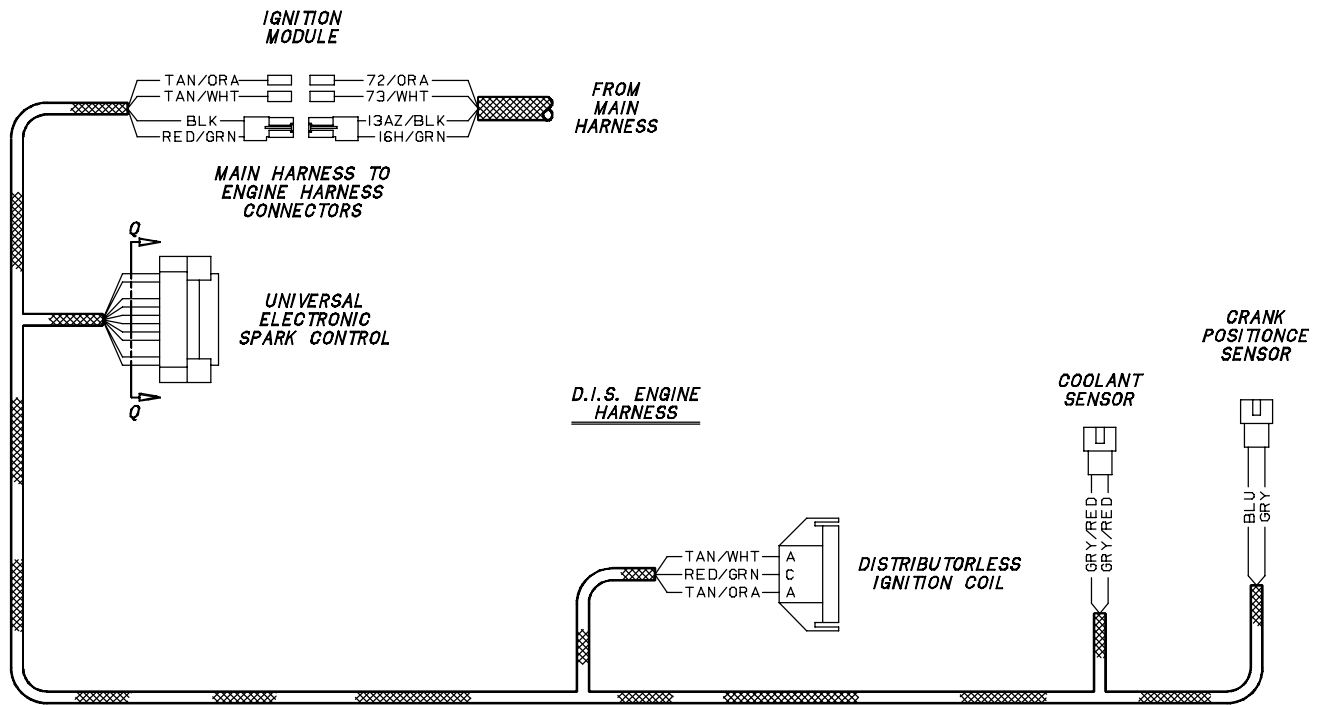
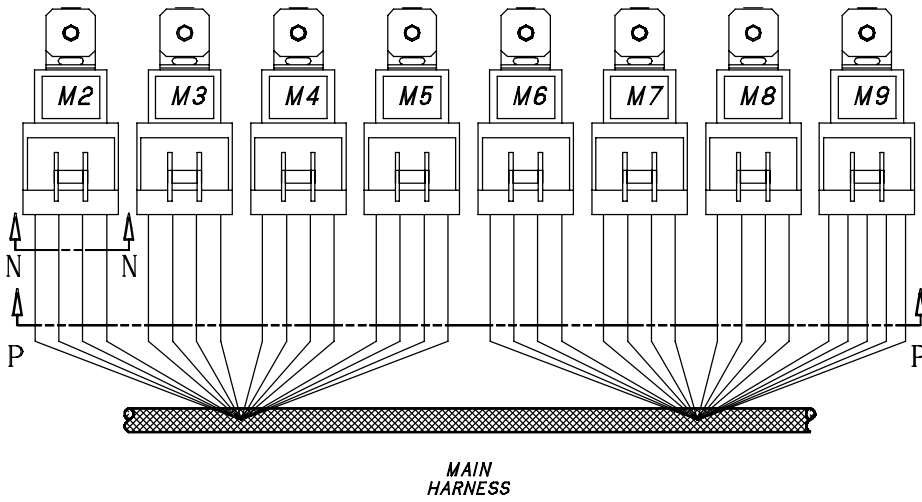

11077-8410 G, LP

GAS/LP WIRE HARNESS GROUP

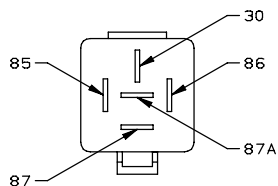

- 85 COIL +
- 86 COIL -
- 30 COMMON CONTACT
- 87 N.O. CONTACT
- 87A N.C. CONTACT

VIEW N-N

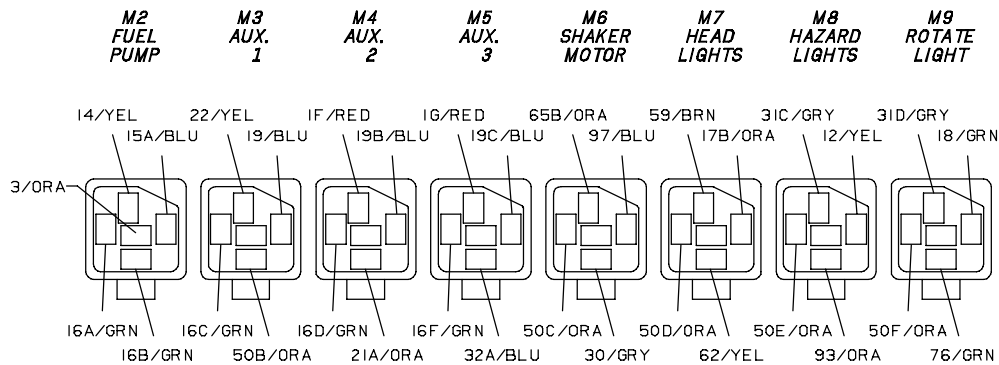

VIEW P-P

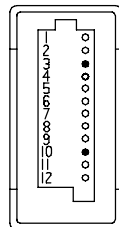

- #1 — BLUCRANKSHAFT POS.
- #2 — GRYCRANKSHAFT POS.
- #3 — NOT USED...NOT USED
- #4 — GRY/RED.....COOLANT TEMP.
- #5 — GRY/RED.....COOLANT TEMP.
- #6 — YEL/BLK.....ADVANCE SPARK 4°
- #7 — YEL/BLK.....ADVANCE SPARK 2°
- #8 — RED/GRN.....IGN. +12
- #9 — BLKGROUND
- #10 — NOT USED...NOT USED
- #11 — TAN/WHTCOIL #1
- #12 — TAN/ORACOIL #2

VIEW Q-Q

**UNIVERSAL
ELECTRONIC
SPARK CONTROL**

GAS/LP WIRE HARNESS GROUP

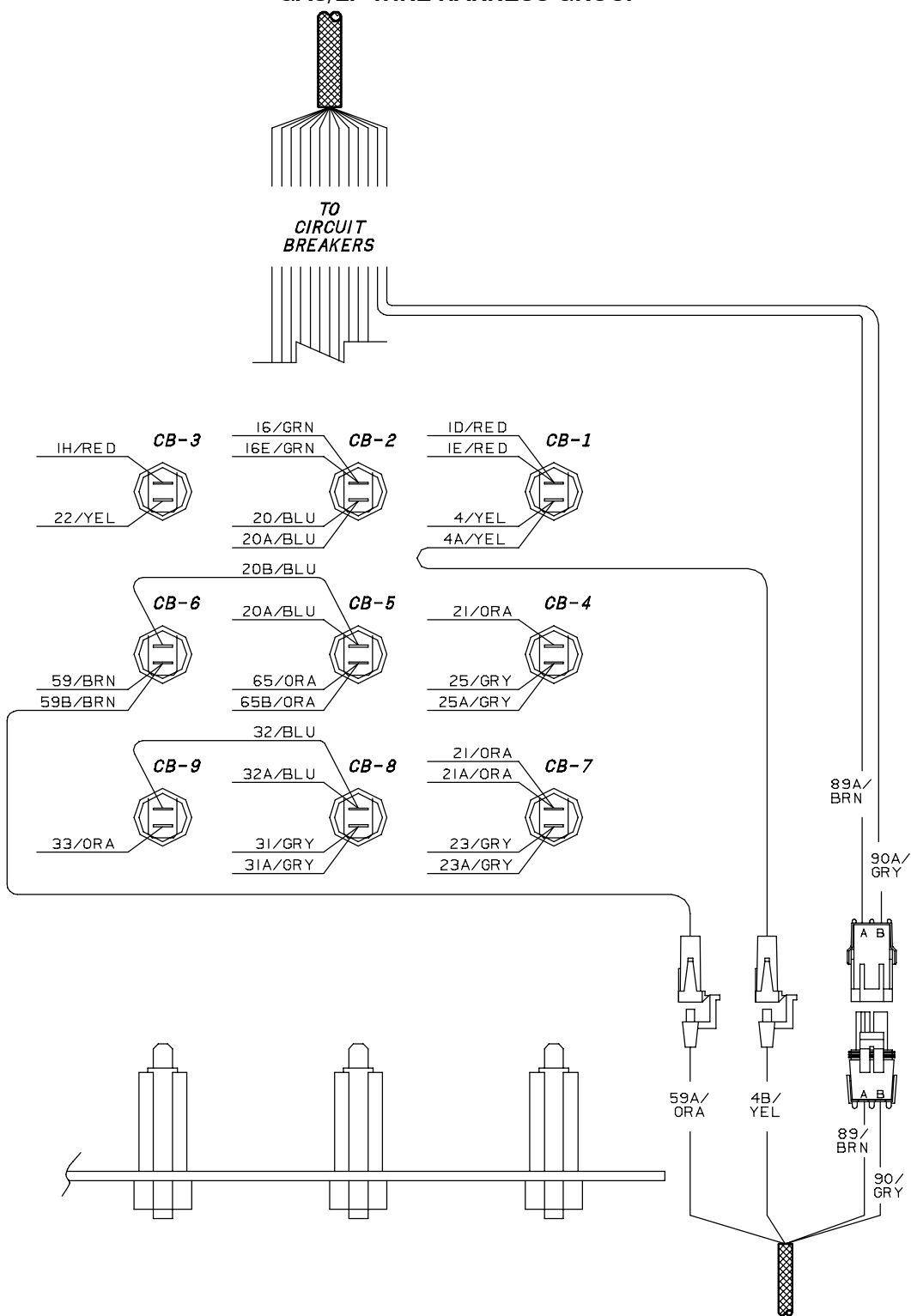

- CIRCUIT BREAKERS**
NO AMPS
- 1 15 ENGINE ELECTRICAL
 - 2 15 VAC FAN AND SHAKER
 - 3 15 HEAD LIGHTS - BRAKE LIGHTS
 - 4 15 SCRUB FUNCTIONS
 - 5 15 HORN - TURN SIGNAL
 - 6 10 INSTRUMENT PANELS
 - 7 15 SWEEP FUNCTIONS
 - 8 15 HAZARD LIGHTS/BACKUP ALARM - OPTION
 - 9 15 E.S. PUMP - OPTION

**FLASHER SWITCH,
 BRAKE SWITCH,
 AND TURN SIGNAL
 HARNESS**

11077-8410 G, LP

GAS/LP WIRE HARNESS GROUP

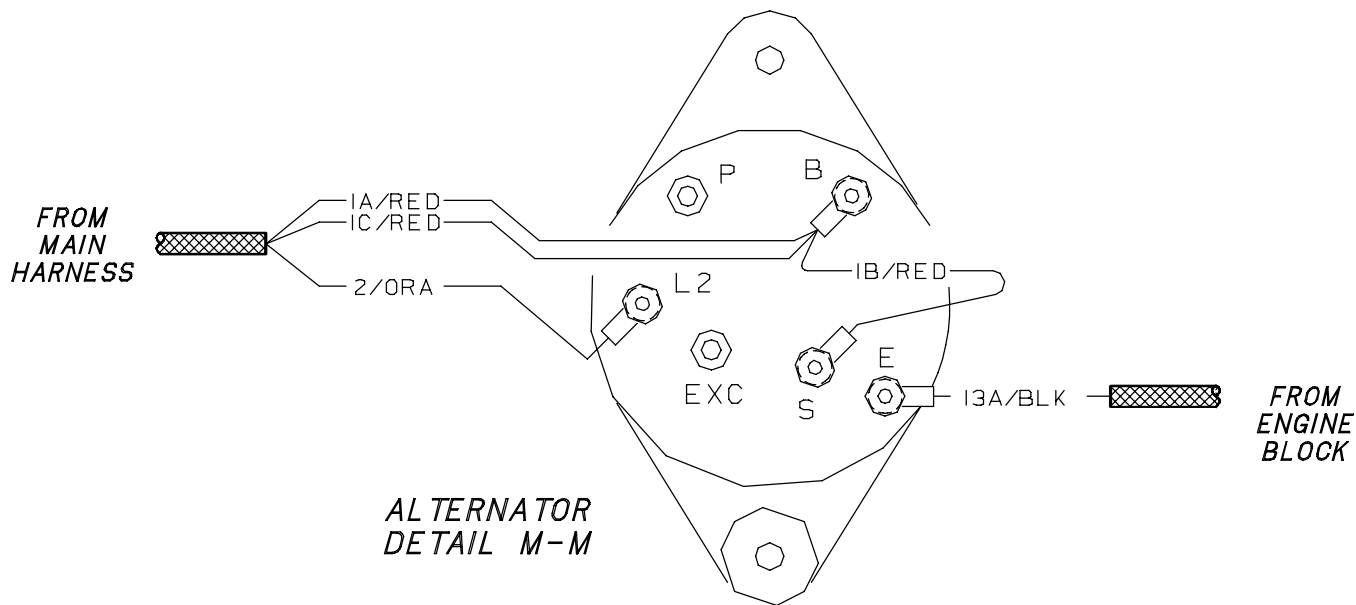

CONNECTOR WIRING

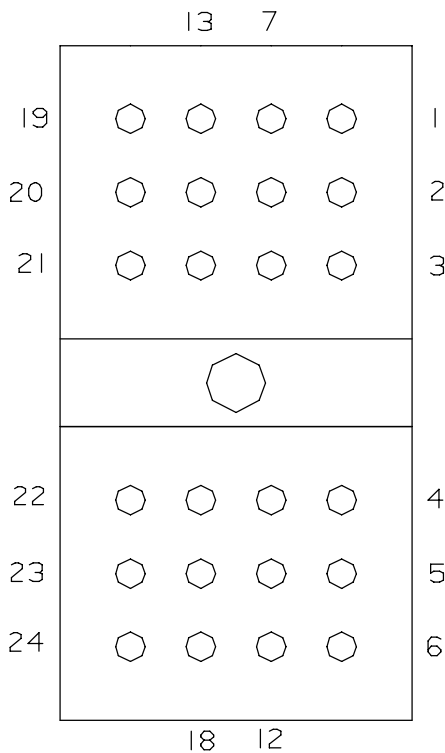

**MAIN/AUXILLARY
INSTRUMENT PANEL
REAR VIEW
(REFERENCE ONLY)**

| SOC. NO. | CONN. C. | CONN. D. |
|----------|----------|----------|
| 1 | 50A/GRY | 50J/ORA |
| 2 | 50H/ORA | 50G/ORA |
| 3 | 24A/PUR | 26/BRN |
| 4 | 17A/ORA | 57/GRN |
| 5 | 97/BLU | 43/BLU |
| 6 | 35/YEL | 6/YEL |
| 7 | 46A/BRN | 7/BLU |
| 8 | 53/BRN | 36/GRN |
| 9 | 38/GRN | 56/YEL |
| 10 | 36A/GRN | 28/YEL |
| 11 | 7A/BLU | 47/ORA |
| 12 | 40/BRN | 51/PUR |
| 13 | 18/GRN | 42/YEL |
| 14 | 39/ORA | 2/O RA |
| 15 | 83A/BRN | 15/BLU |
| 16 | 44/YEL | 48/BLU |
| 17 | 49/GRN | 83/BRN |
| 18 | 37/YEL | 24/PUR |
| 19 | 12/YEL | 46/BRN |
| 20 | 41/PUR | 17/ORA |
| 21 | 34/BRN | 45/GRN |
| 22 | 13AF/BLK | 13AB/BLK |
| 23 | 13AG/BLK | 13AC/BLK |
| 24 | 13AH/BLK | 13AD/BLK |

11077-8410 G, LP

GAS/LP WIRE HARNESS GROUP

- SV-5 MAIN BRUSH ON - NORMAL SPEED
- SV-6 MAIN BRUSH ON - LITTER SPEED
- SV-8 HOPPER UP
- SV-9 HOPPER DOWN
- SV-10 EDGE SCRUB OUT
- SV-11 MAIN BRUSH DOWN
- SV-12 SQUEEGEE DOWN

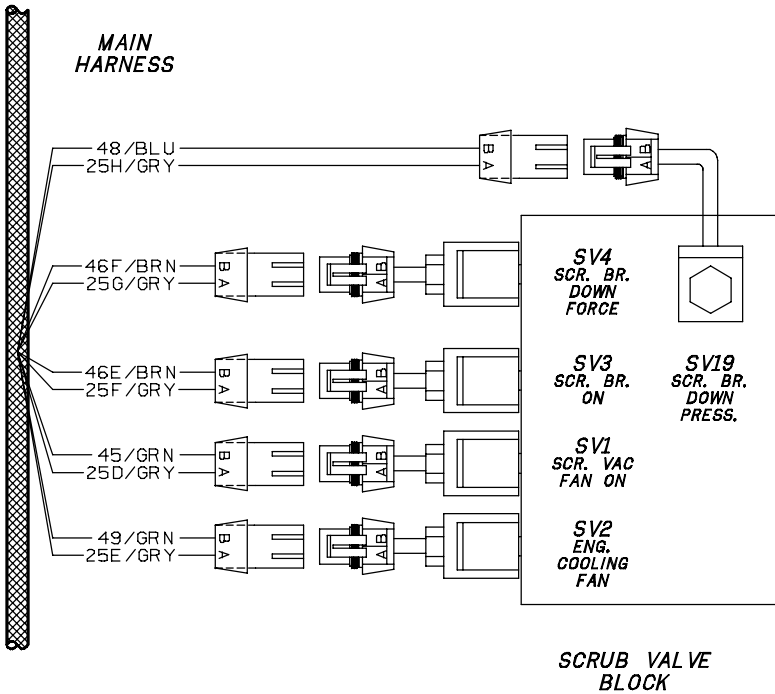
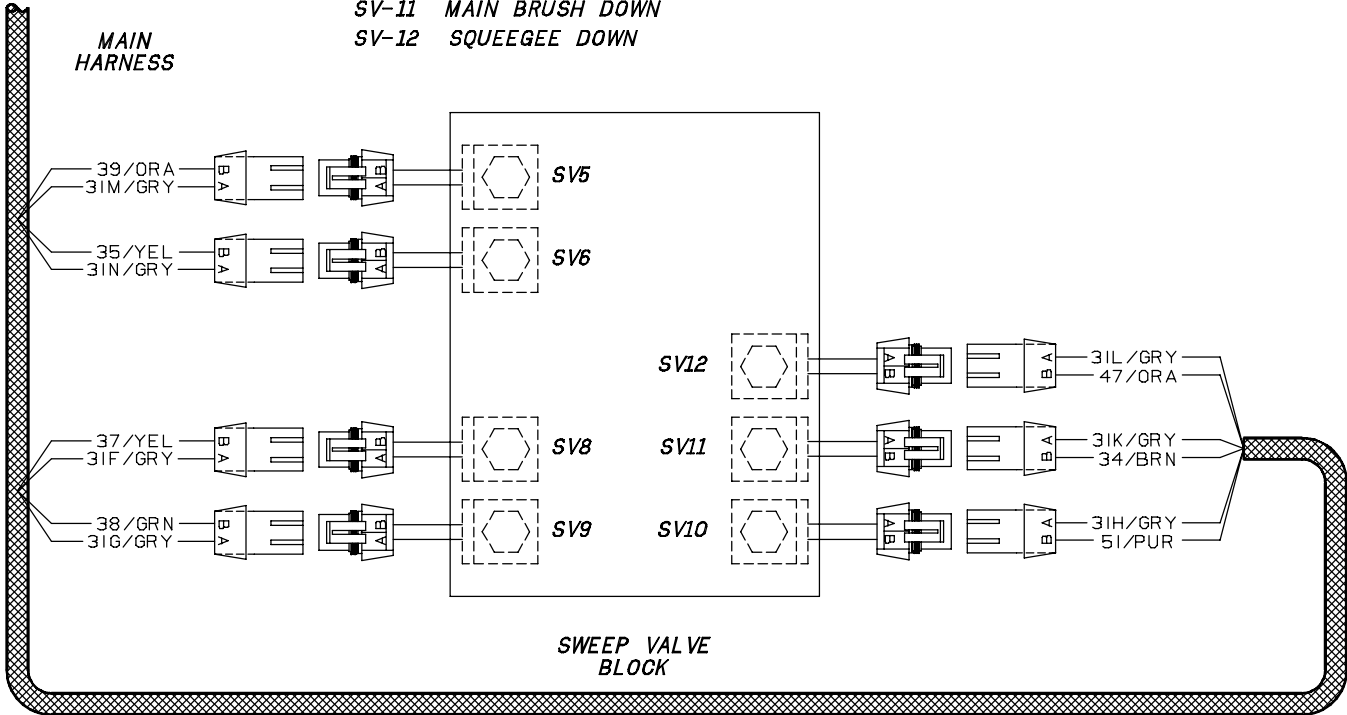

GAS/LP WIRE HARNESS GROUP

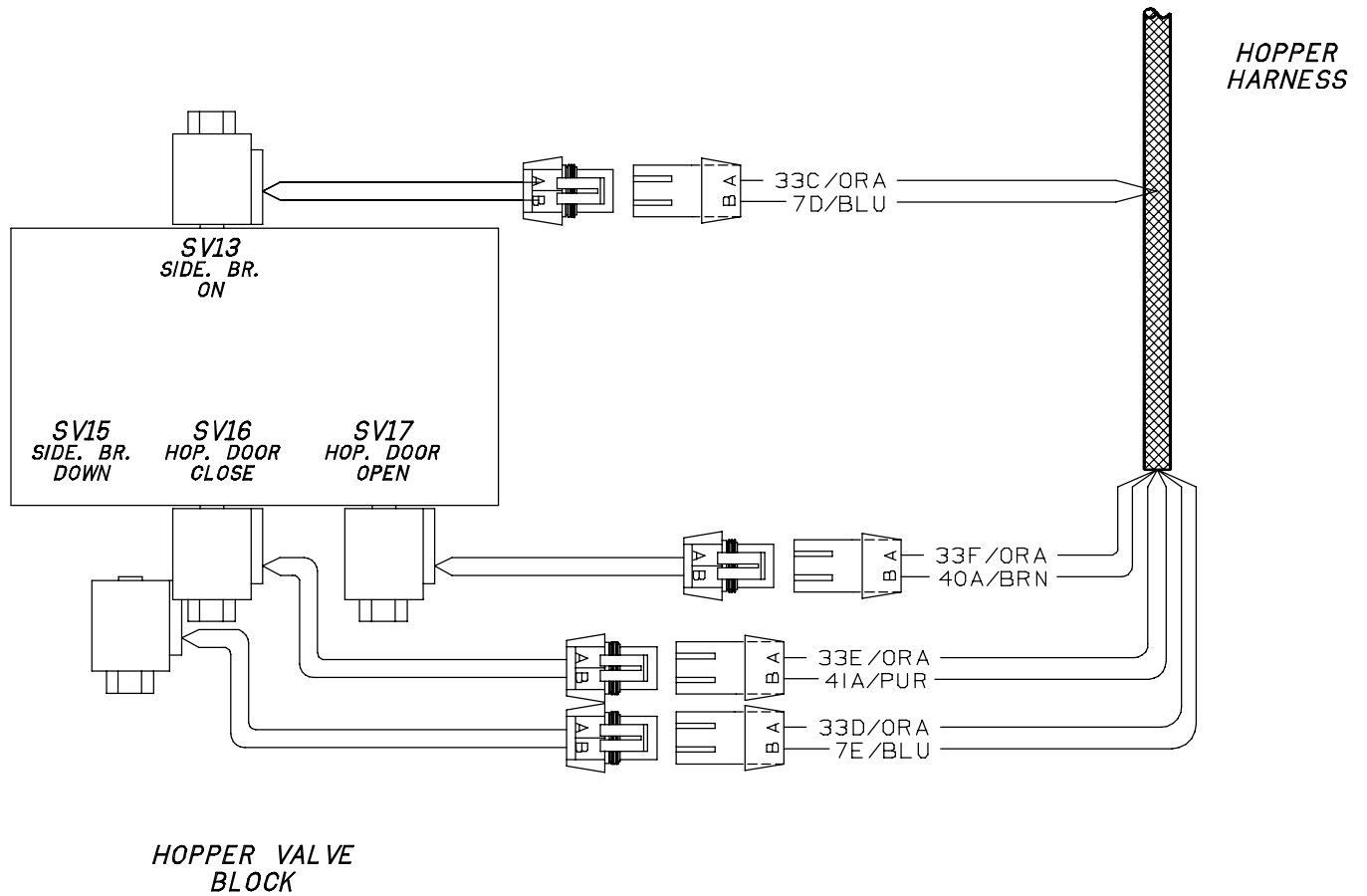

GAS/LP WIRE HARNESS GROUP

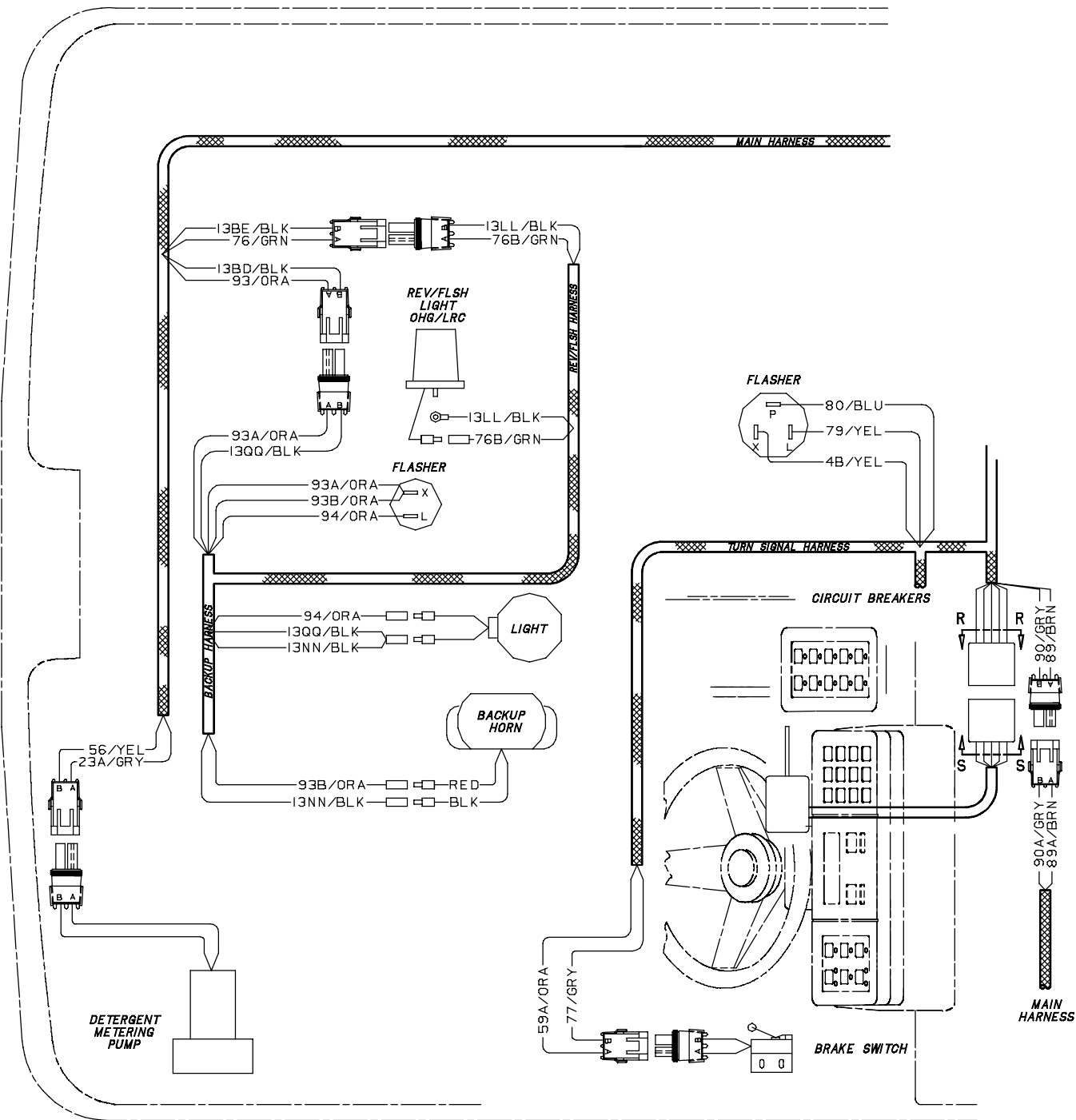

OPTIONS

11077-8410 G, LP

GAS/LP WIRE HARNESS GROUP

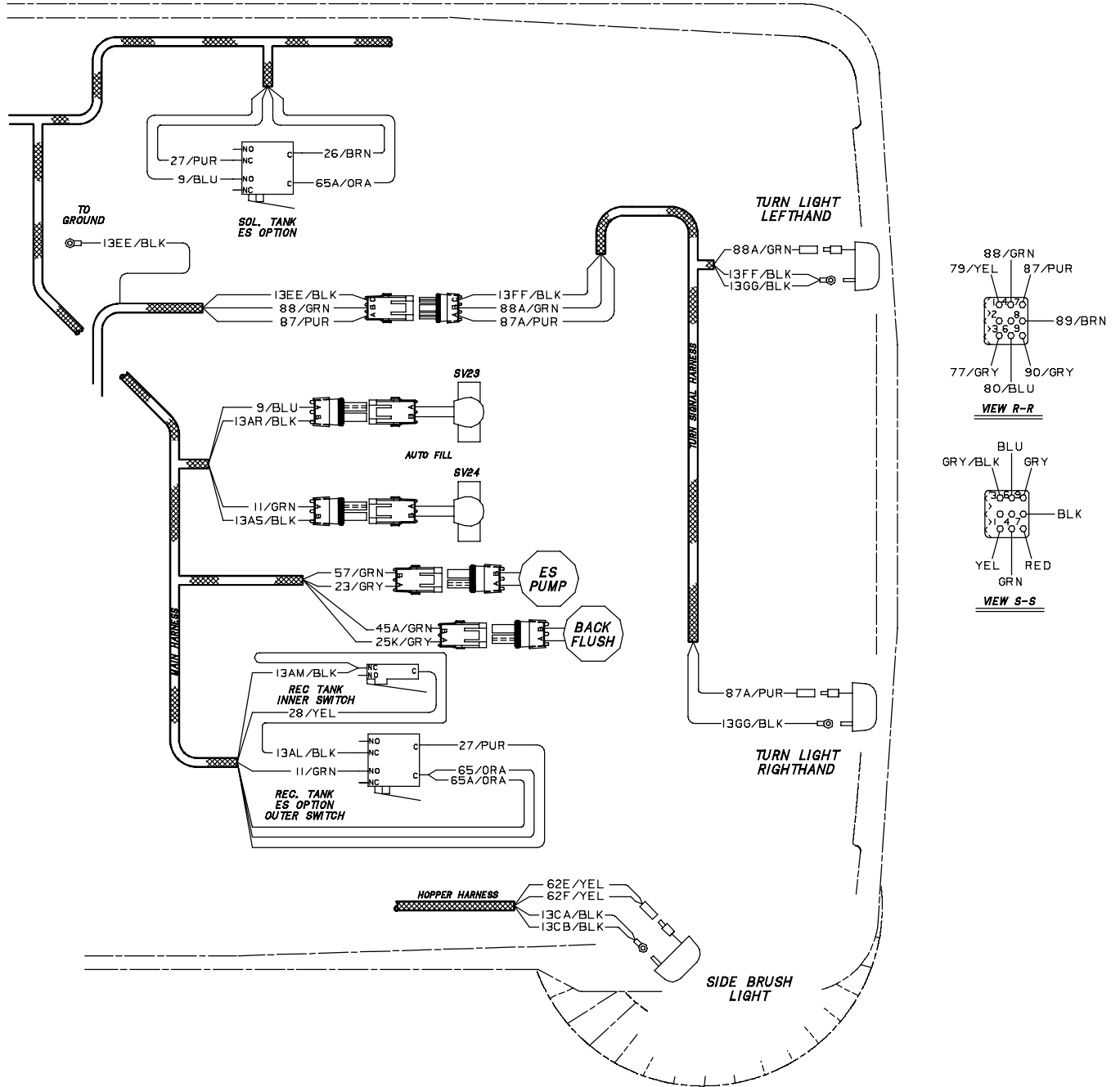

OPTIONS

11077-8410 G, LP

DIESEL ELECTRICAL SCHEMATIC

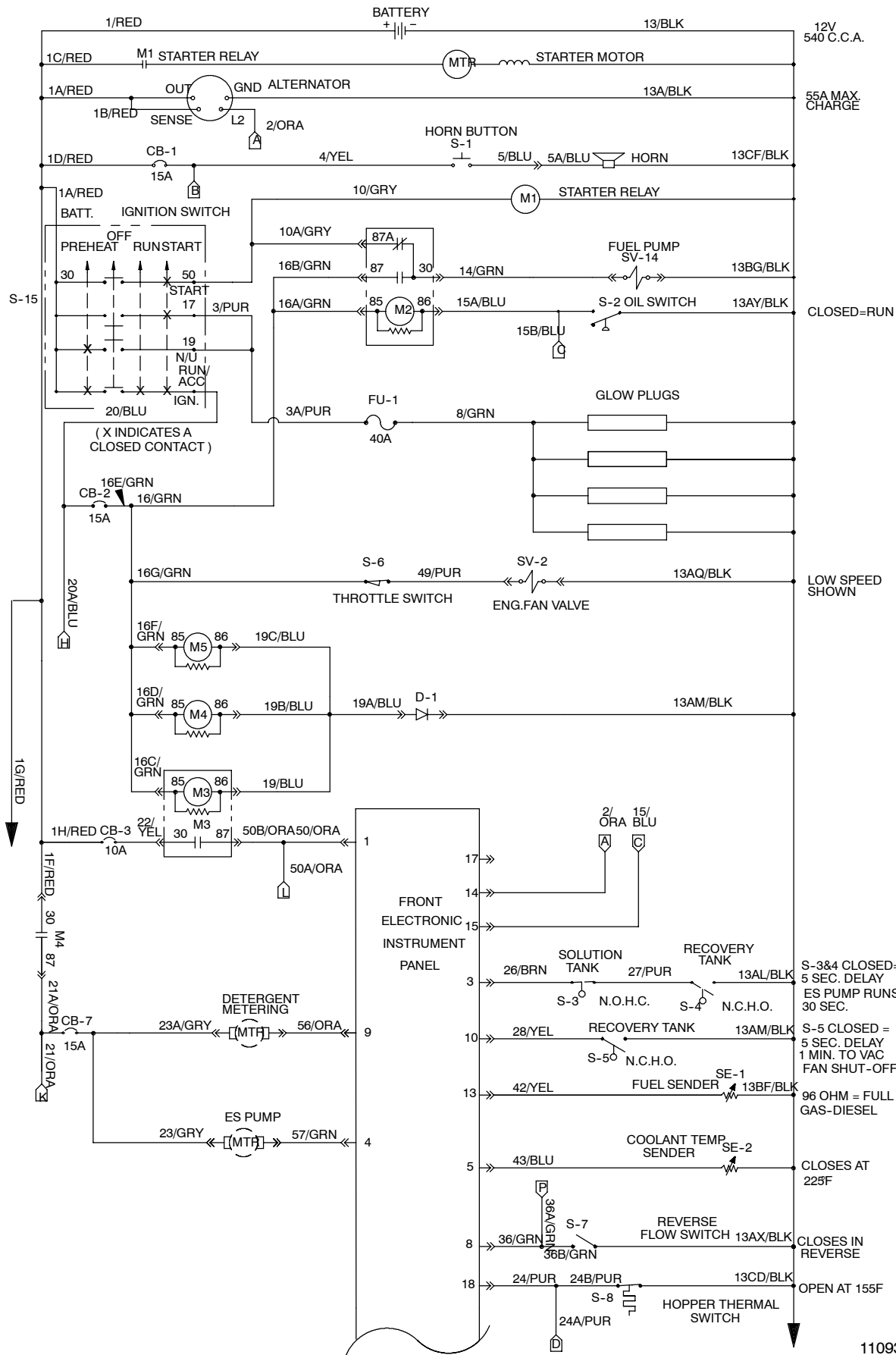

11093-8410 D

DIESEL ELECTRICAL SCHEMATIC

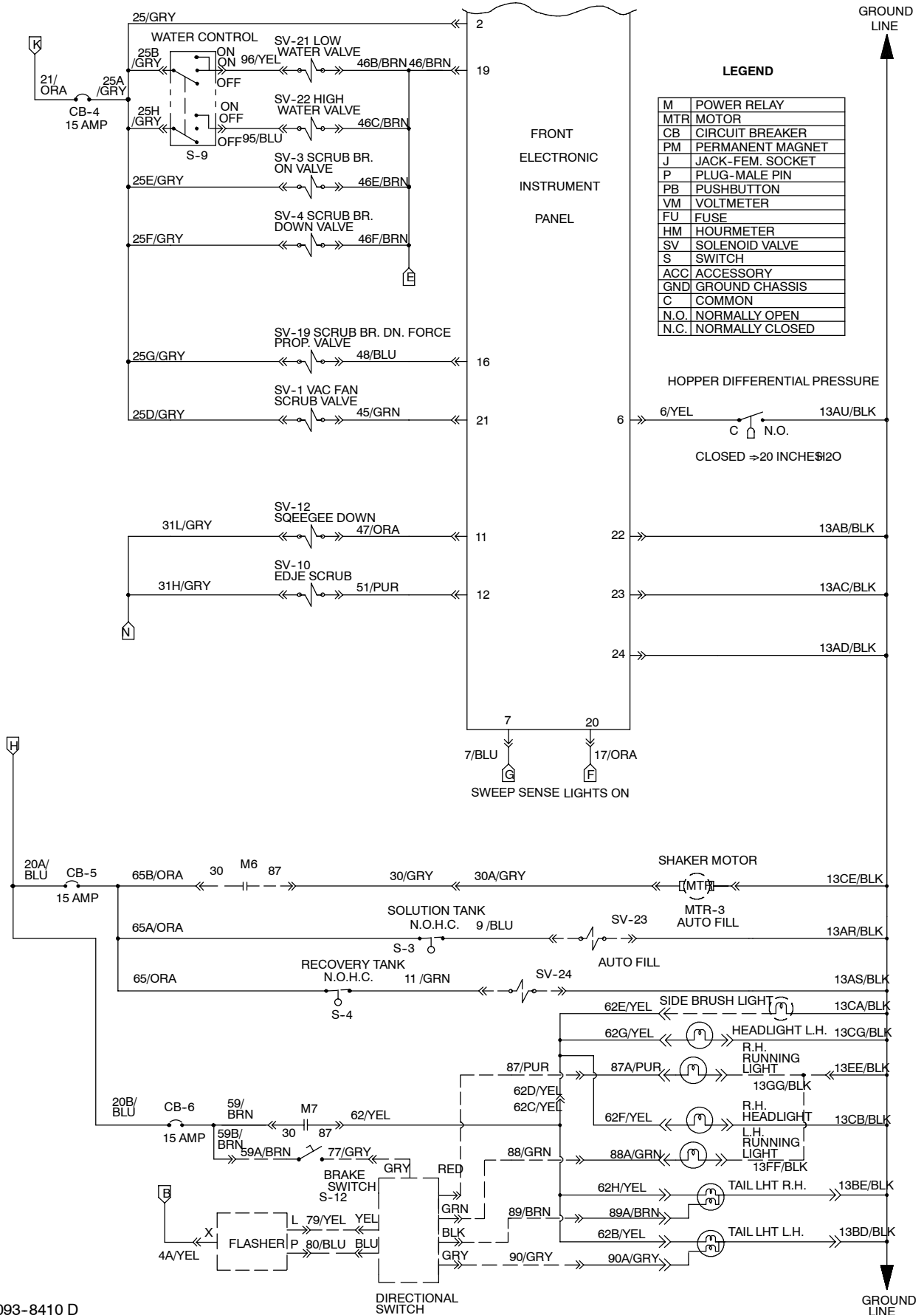

LEGEND

| | |
|------|------------------|
| M | POWER RELAY |
| MTR | MOTOR |
| CB | CIRCUIT BREAKER |
| PM | PERMANENT MAGNET |
| J | JACK-FEM. SOCKET |
| P | PLUG-MALE PIN |
| PB | PUSHBUTTON |
| VM | VOLTMETER |
| FU | FUSE |
| HM | HOURLMETER |
| SV | SOLENOID VALVE |
| S | SWITCH |
| ACC | ACCESSORY |
| GND | GROUND CHASSIS |
| C | COMMON |
| N.O. | NORMALLY OPEN |
| N.C. | NORMALLY CLOSED |

HOPPER DIFFERENTIAL PRESSURE

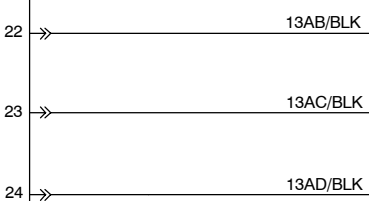
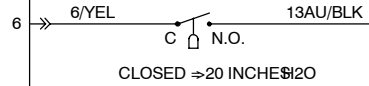

11093-8410 D

DIESEL ELECTRICAL SCHEMATIC

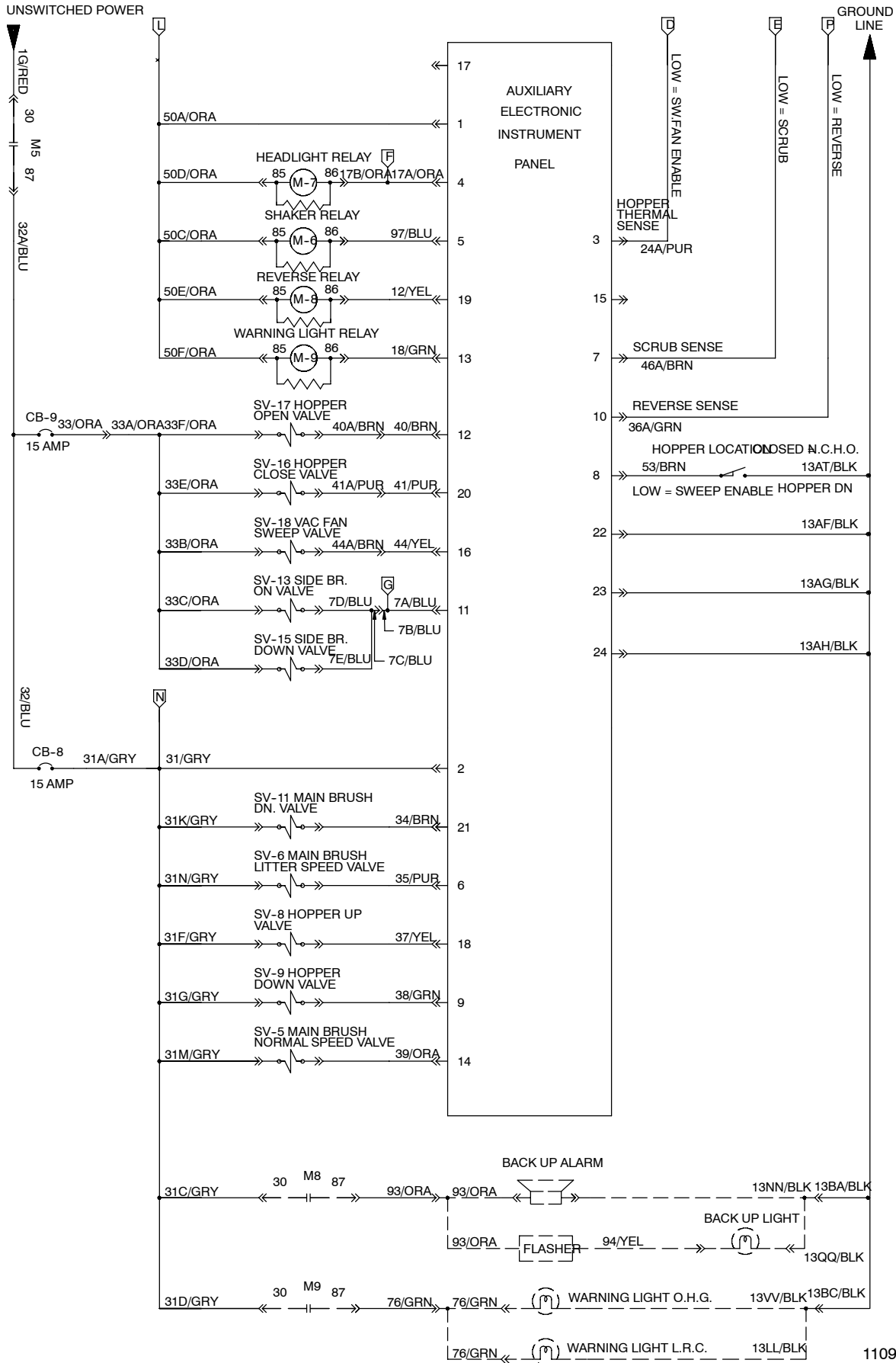

11093-8410 D

DIESEL WIRE HARNESS GROUP

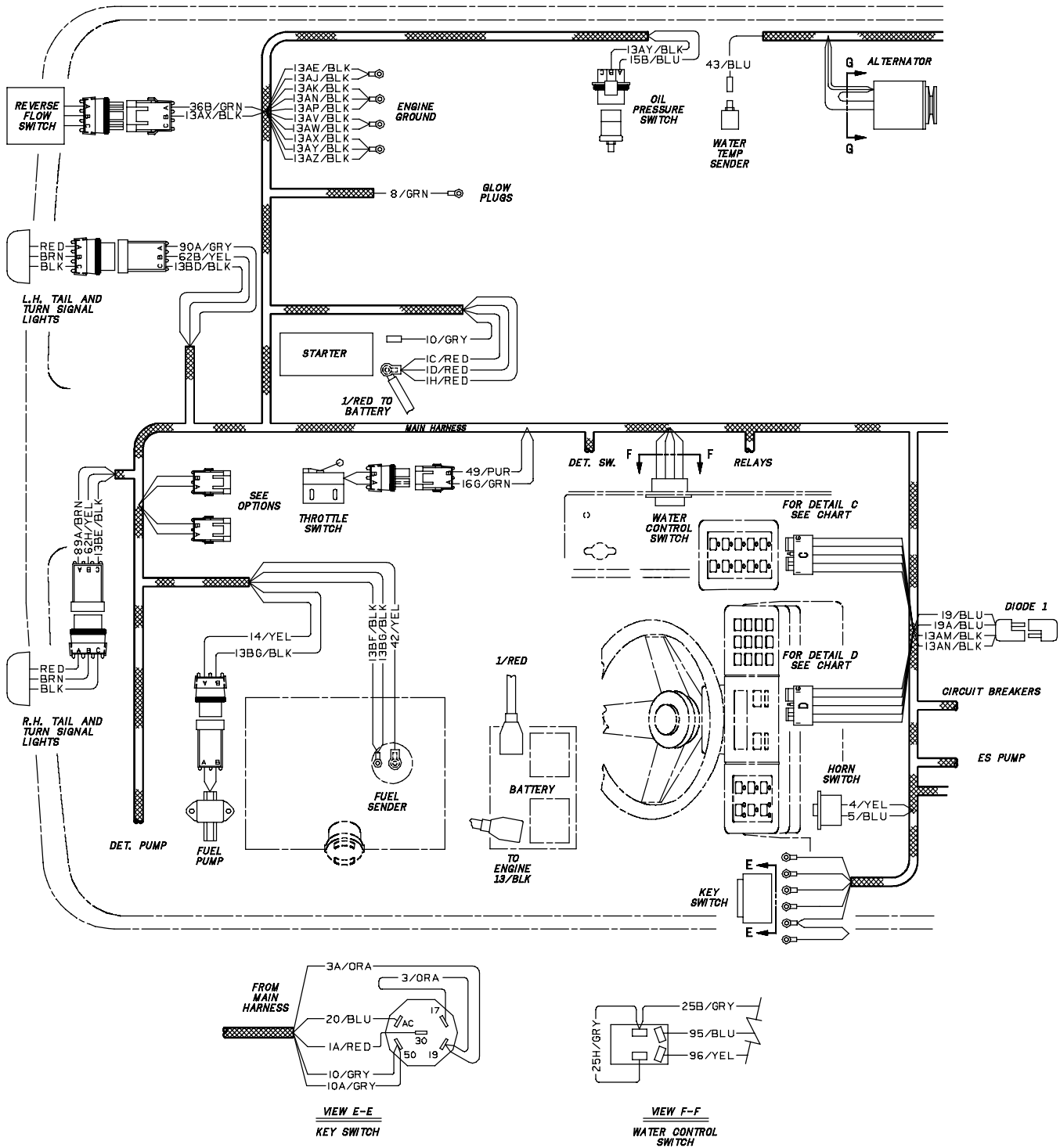

11093-8410 D

DIESEL WIRE HARNESS GROUP

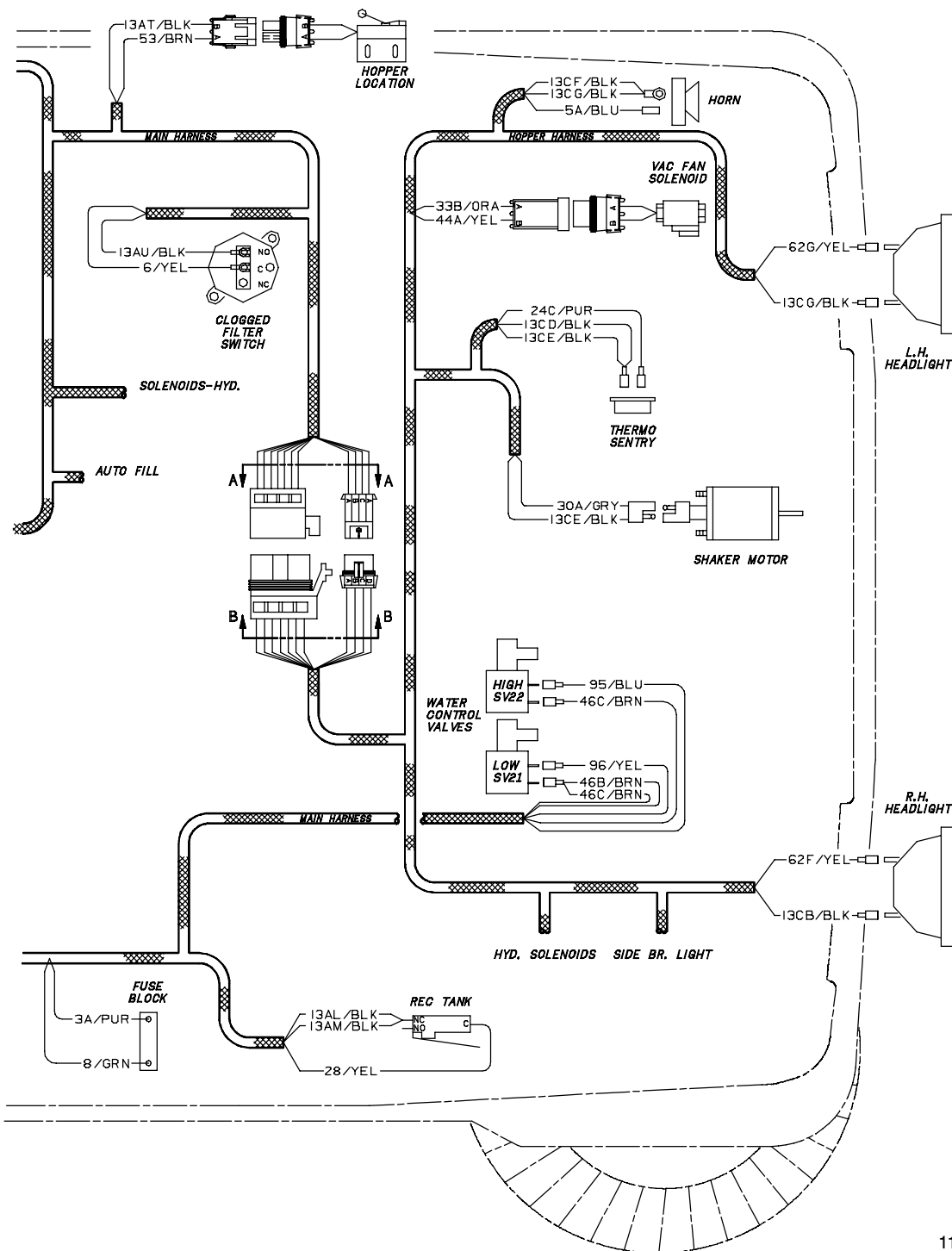
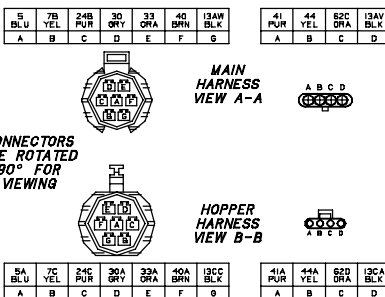

11093-8410 D

DIESEL WIRE HARNESS GROUP

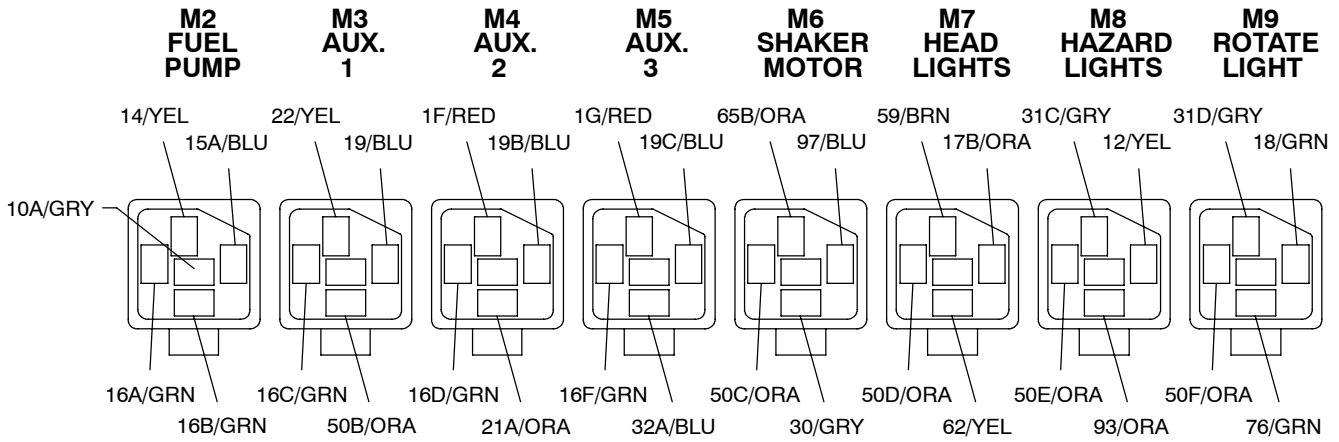

VIEW J-J

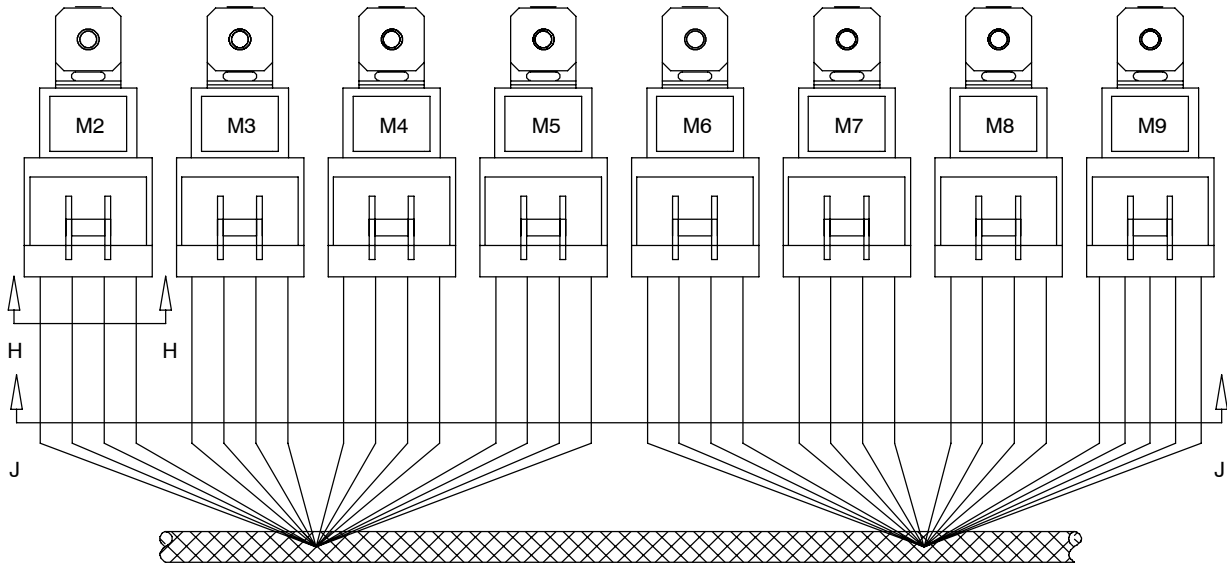

MAIN HARNESS

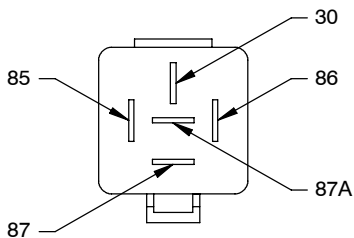

- 85 COIL+
- 86 COIL -
- 30 COMMON CONTACT
- 87 N.O. CONTACT
- 87A N.C. CONTACT

VIEW H-H

11093-8410 D

DIESEL WIRE HARNESS GROUP

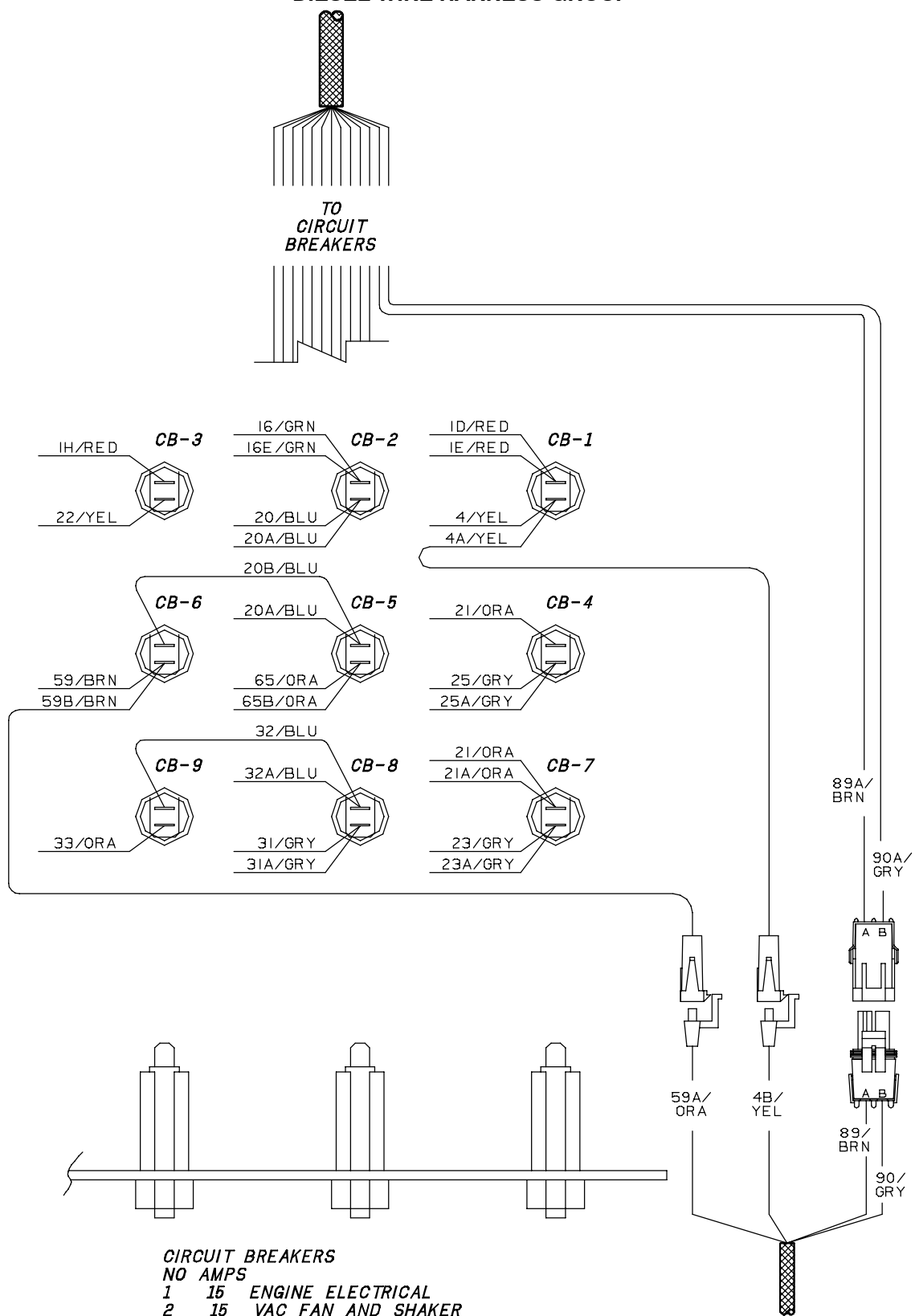

CIRCUIT BREAKERS
NO AMPS

- 1 15 ENGINE ELECTRICAL
- 2 15 VAC FAN AND SHAKER
- 3 15 HEAD LIGHTS - BRAKE LIGHTS
- 4 15 SCRUB FUNCTIONS
- 5 15 HORN - TURN SIGNAL
- 6 10 INSTRUMENT PANELS
- 7 15 SWEEP FUNCTIONS
- 8 15 HAZARD LIGHTS/BACKUP ALARM - OPTION
- 9 15 E.S. PUMP - OPTION

FLASHER SWITCH,
BRAKE SWITCH,
AND TURN SIGNAL
HARNESS

11093-8410 D

DIESEL WIRE HARNESS GROUP

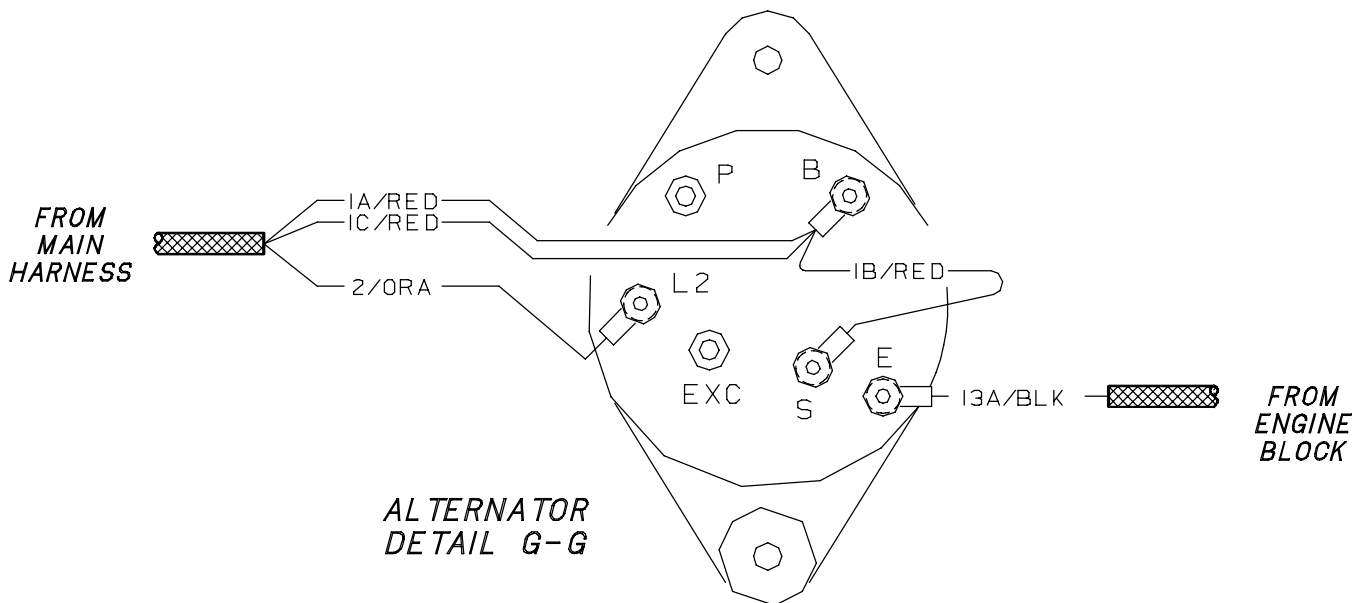

CONNECTOR WIRING

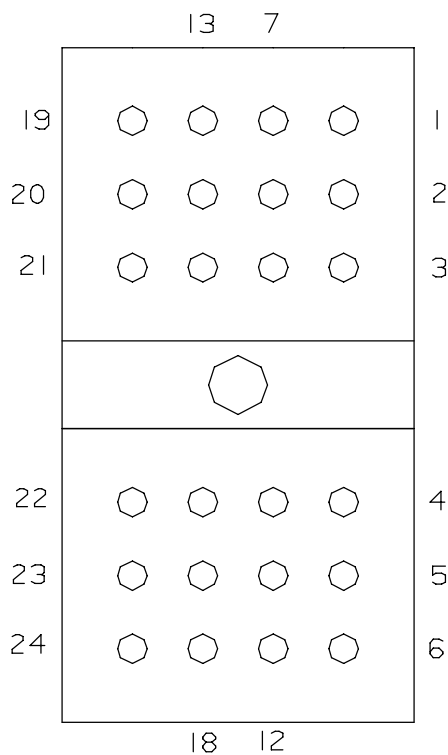

**MAIN/AUXILLARY
INSTRUMENT PANEL
REAR VIEW
(REFERENCE ONLY)**

| SOC. NO. | CONN. C. | CONN. D. |
|----------|------------|------------|
| 1 | 50A/GRY | 50J/ORANGE |
| 2 | 50H/ORANGE | 50G/ORANGE |
| 3 | 24A/PUR | 26/BRN |
| 4 | 17A/ORANGE | 57/GRN |
| 5 | 97/BLU | 43/BLU |
| 6 | 35/YEL | 6/YEL |
| 7 | 46A/BRN | 7/BLU |
| 8 | 53/BRN | 36/GRN |
| 9 | 38/GRN | 56/YEL |
| 10 | 36A/GRN | 28/YEL |
| 11 | 7A/BLU | 47/ORANGE |
| 12 | 40/BRN | 51/PUR |
| 13 | 18/GRN | 42/YEL |
| 14 | 39/ORANGE | 2/ORANGE |
| 15 | PLUG | 15/BLU |
| 16 | 44/YEL | 48/BLU |
| 17 | PLUG | PLUG |
| 18 | 37/YEL | 24/PUR |
| 19 | 12/YEL | 46/BRN |
| 20 | 41/PUR | 17/ORANGE |
| 21 | 34/BRN | 45/GRN |
| 22 | 13AF/BLACK | 13AB/BLACK |
| 23 | 13AG/BLACK | 13AC/BLACK |
| 24 | 13AH/BLACK | 13AD/BLACK |

11093-8410 D

DIESEL WIRE HARNESS GROUP

- SV-5 MAIN BRUSH ON - NORMAL SPEED
- SV-6 MAIN BRUSH ON - LITTER SPEED
- SV-8 HOPPER UP
- SV-9 HOPPER DOWN
- SV-10 EDGE SCRUB OUT
- SV-11 MAIN BRUSH DOWN
- SV-12 SQUEEGEE DOWN

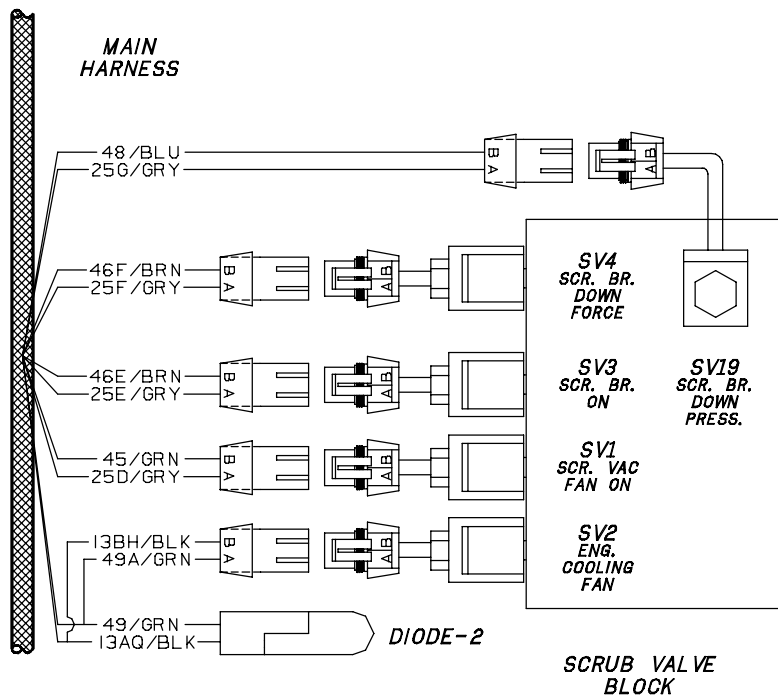
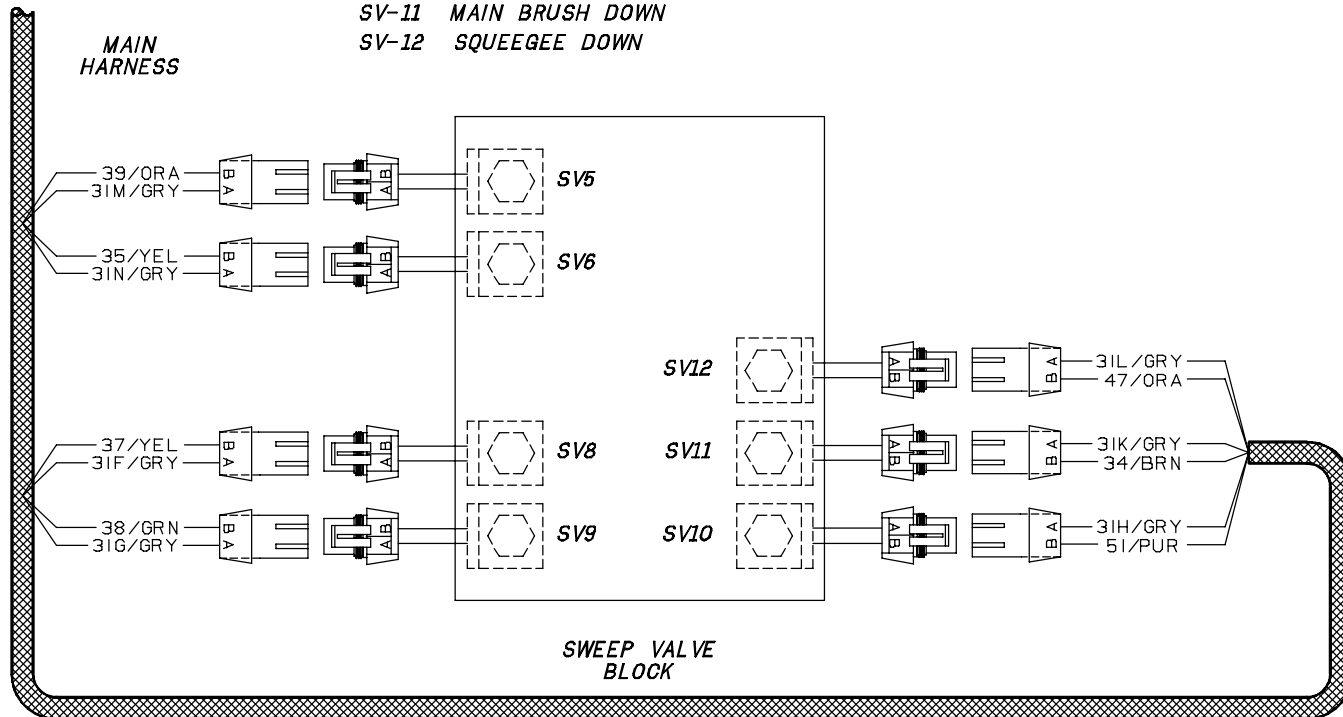

11093-8410 D

DIESEL WIRE HARNESS GROUP

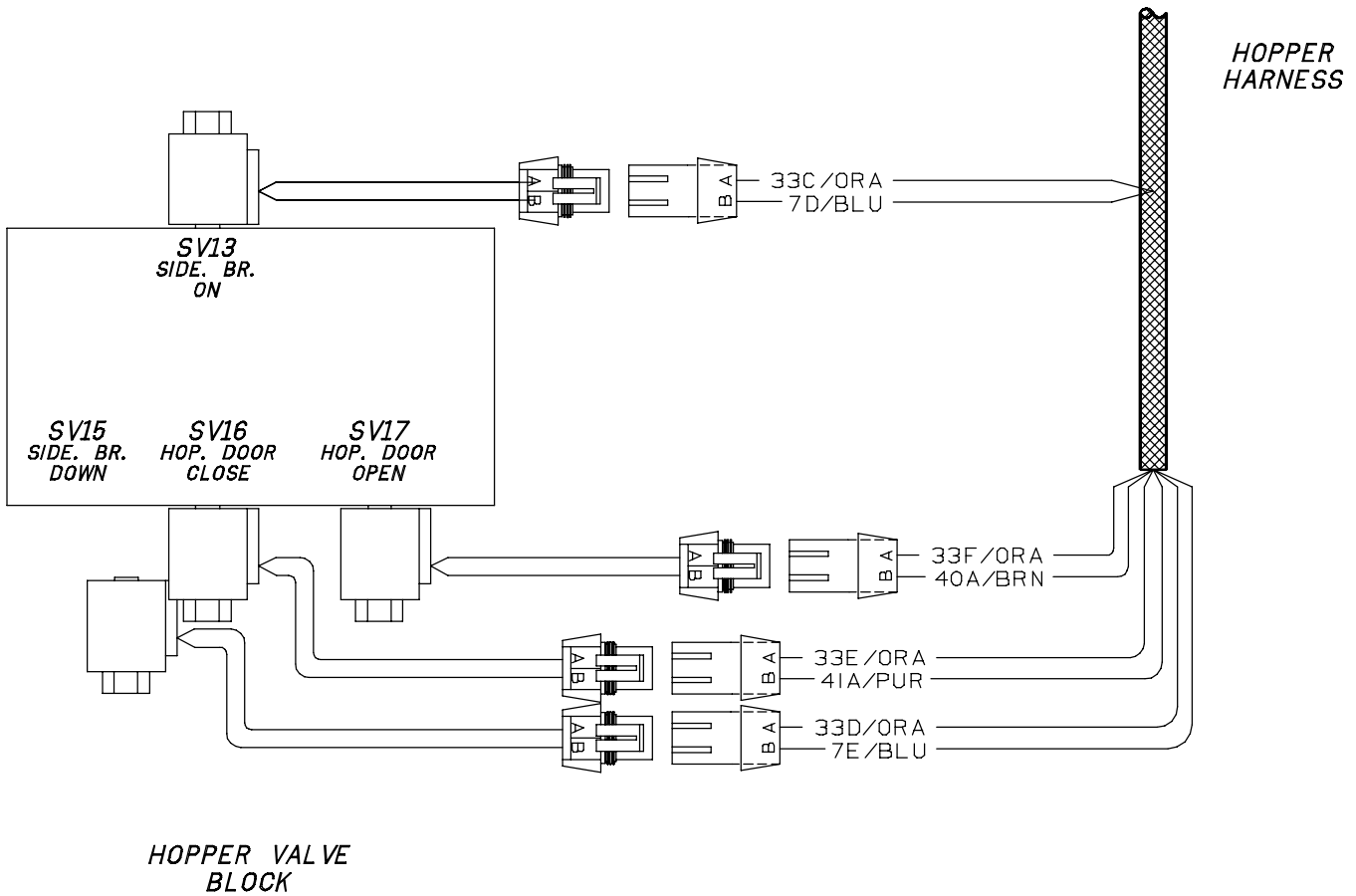

DIESEL WIRE HARNESS GROUP

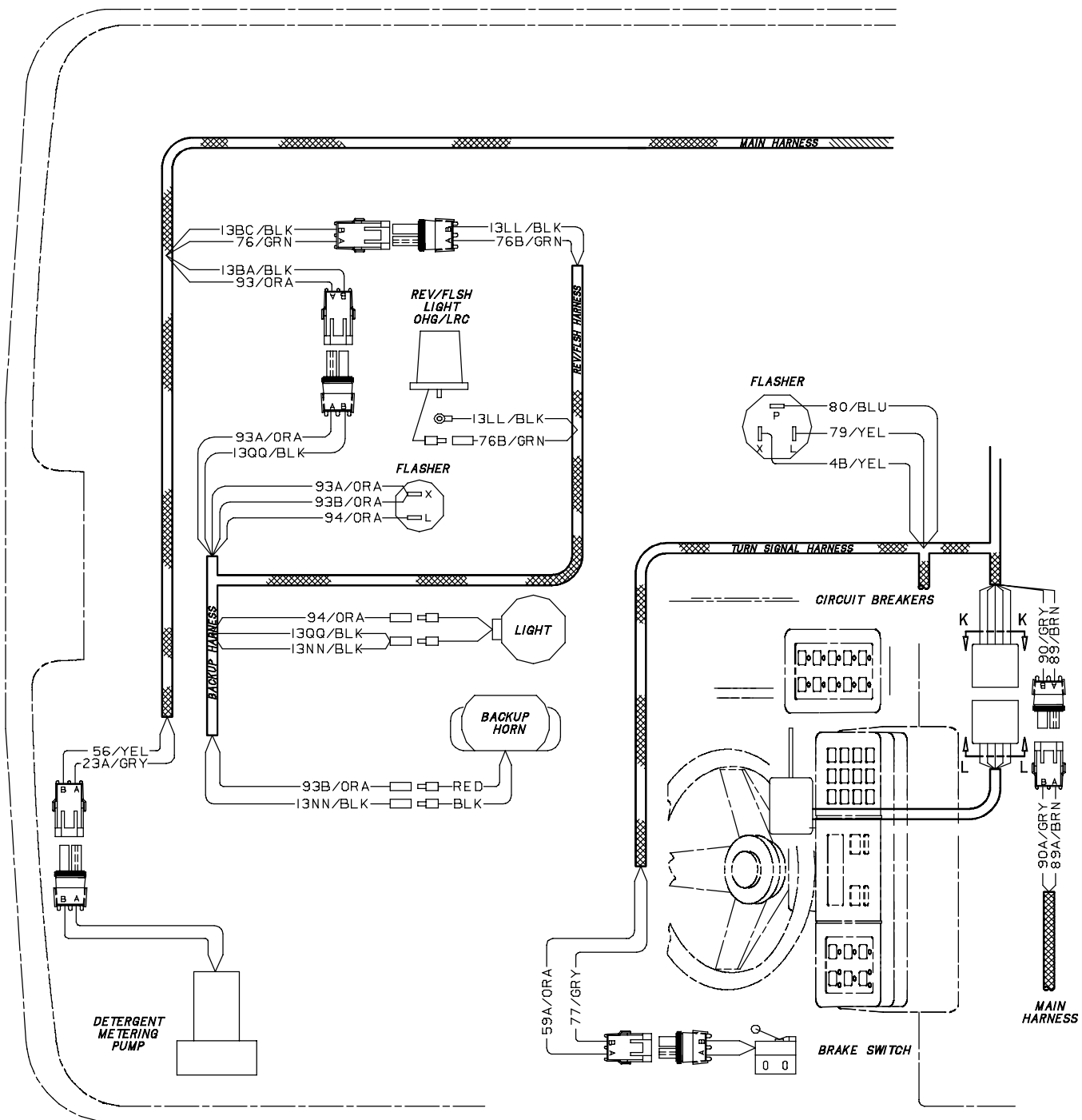

OPTIONS

11093-8410 D

DIESEL WIRE HARNESS GROUP

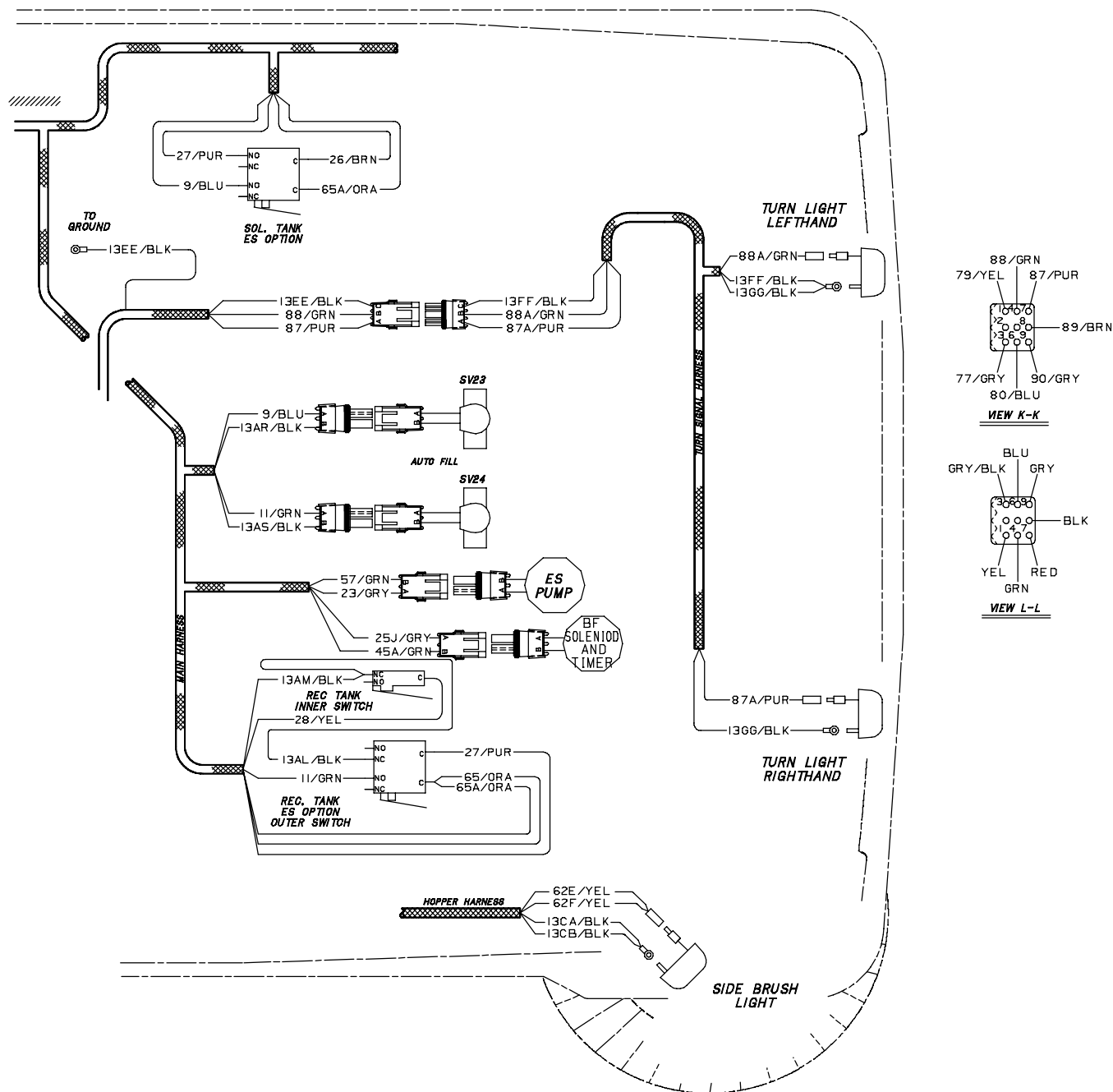

OPTIONS

11093-8410 D

DIAGNOSTICS

The Model 8410 sweeper scrubber has a on-board diagnostic system.

When the operator turns on the ignition key on the 8410, the front and side panels will each perform an independent self test. If the self test for the front panel passes, the OK light will begin to blink. If the side panel passes its self test, it will blink the headlight. When the main panel sees the headlights blink, it assumes the side panel has passed its self test. When both boards have passed the self test, the OK light will go to a steady on condition.

The 8410 front panel has 6 operating modes. The side panel has 4 operating modes. The user can access each mode by depressing various control buttons, holding them, and turning on the key. The common operating modes are as follows:

The first part of the diagnostics section describes the different operating modes that can be activated by using an entry sequence on the front and side panels. There is also a chart describing the normal mode messages that may appear on the dash panel.

The second part of the diagnostics section includes a chart that details the error messages that may appear on the dash panel during the self test mode and the cause/corrective action description.

The third part of the diagnostics is a trouble shooting section that includes a flow chart detailing the flow of the electrical circuits.

FRONT PANEL OPERATING MODES

The 8410 front panel has a total of six operating modes. When the operator starts the machine, the panel will run its self test, then return to the normal operating mode. The operator can access five maintenance modes by turning the machine off, pressing and holding the appropriate button, turning the machine on, and holding the button until the maintenance light comes on.

The following chart will detail each mode and the entry sequence.

| Operating Modes | Entry Sequence (how to activate) |
|---|--|
| Normal Mode; <i>Normal operation.</i> More info pages 5-35 thru 5-37 | Default (when key is turned on) |
| Manual Mode; <i>Manually operate discrete functions without interlocks.</i> More info page 5-38 | <ol style="list-style-type: none"> 1. Push and hold the ES™ button 2. Turn on the key 3. Hold the ES™ button until the maintenance light comes on. 4. Release the ES™ button 5. To exit--turn off key |
| Input Display Mode; <i>Display the state of floats, limit switches, and sensors.</i> More info page 5-39 | <ol style="list-style-type: none"> 1. Push and hold the Squeegee button 2. Turn on the key 3. Hold the Squeegee button until the maintenance light comes on 4. Release the Squeegee button 5. To exit--turn off key |
| Error Display Mode; <i>Display the cause of a self test failure.</i> More info pages 5-40 thru 5-42 | <ol style="list-style-type: none"> 1. Push and hold the Detergent button 2. Turn on the key 3. Hold the Detergent button until the maintenance light comes on. 4. Release the Detergent button 5. To exit--turn off key |
| Pressure Adjust Mode; <i>Adjust pressure levels for the three down pressure settings.</i> More info page 5-43 | <ol style="list-style-type: none"> 1. Push and hold the Edge Scrub button 2. Turn on the key 3. Hold the Edge Scrub button until the maintenance light comes on. 4. Release the Edge Scrub button 5. To exit--turn off key |
| Reset Scrub Pressures; <i>Return the down pressure settings to the factory defaults.</i> More info page 5-44 | <ol style="list-style-type: none"> 1. Push and hold the Scrub button 2. Turn on the key 3. Continue to hold the Scrub button 4. Wait for the maintenance light. 5. While holding the Scrub button, press and hold the Edge Scrub button. 6. Wait for the maintenance light to go out. 7. Release the Scrub and Edge scrub buttons. 8. Turn the key off. 9. Restart the machine. |

| Operating Mode | Entry Sequence (how to activate) |
|---------------------------------------|-------------------------------------|
| Normal Mode; <i>Normal operation.</i> | Default (when key is turned on) |

NORMAL MODE

The purpose of the normal mode is for the general operation of the machine. The machine will normally start in this mode. What follows is a brief description of each buttons operation in the normal mode.

EDGE SCRUB:

1. Pressing the Edge scrub button will toggle the Edge scrub LED.
2. If the machine is in the scrub mode, the Edge scrub LED is on, no reverse condition is being sensed, and the machine is running at high engine speed, the scrub head will shift into the edge scrub position.
3. If the machine is in the scrub mode and the Edge scrub LED is off, the scrub head will be in the retracted position.

SQUEEGEE:

1. If the squeegee LED is off, pressing the squeegee button will drop the squeegee, turn on the vacuum fan, and select high engine speed.
2. If the squeegee LED is on, pressing the squeegee button will raise the squeegee, initiate a delay, and turn off the vacuum fan.
3. The squeegee operation is inhibited in reverse.
4. Squeegee LED will turn off automatically if scrub system is turned off, low engine speed is selected or recovery tank full condition is sensed.

ENGINE SPEED:

1. If the engine is at idle speed, pressing this button will bring it to operating speed.
2. If the scrub mode is active, pressing the engine button will cancel all scrubbing activities.
3. High speed is selected automatically if Scrub, Squeegee, or Sweep 1 or 2 are turned on.

SCRUB:

● *If the scrub function is currently inactive, pressing the scrub button will initiate the following actions:*

1. The engine speed is set to high.
2. The main brushes will turn on and go down. The down pressure setting will be the same used during the last scrub cycle. The squeegee will lower and the scrub vacuum will turn on. The solution will flow at the high or low rate according to the water position switch. The ES™ system, detergent metering system, and the edge scrub will operate if selected by the operator.
3. If the machine is in reverse, the brushes will retract, lift, and turn off.
4. The squeegee will lift and the scrub vacuum fan will turn off.
5. If the low engine speed is selected or an overflow condition is sensed the scrub system is turned off automatically.

● *If the operator pushes and holds the scrub button, the pressure settings will begin to scroll. The pressure setting displayed after releasing the scrub button will become the new default down pressure setting.*

● *If the scrub function was active and the operator pushes, then releases the scrub button, the following actions will take place:*

1. The main brushes will retract, raise and turn off.
2. The solution flow will turn off.
3. The detergent pump will turn off.
4. A seven second delay will pass, and then the rear squeegee will rise.
5. A four second delay will pass and the vacuum fan will turn off.

DETERGENT:

● *Pressing the detergent button will cause the detergent display to scroll through its three modes. The detergent pump will run if the main scrub brushes are active, the solution switch is on, and the machine is not in reverse.*

1. **OFF** (all LED's off)--Detergent pump OFF
2. **LOW** (left LED's on)--Detergent pump LOW.
3. **HIGH** (both LED's on)--Detergent pump HIGH.

ES™ :

● *Pressing the ES™ button will enable or disable the ES™ function. In order for the ES™ float to become active, it must be consistently in the up position for at least 10 seconds. If the ES™ function is enabled and the ES™ float becomes active, the following actions will occur:*

1. The ES™ pump will begin to run.
2. The ES™ pump will continue to run for 40 seconds after the ES™ float becomes uncovered.

OVER FLOW:

● *In order for the recovery tank float to become active, it must be consistently in the up position for least 10 seconds. If the scrub or vacuum fan are active and the tank full float becomes active, the following actions will occur:*

1. The overflow light will begin to blink.
2. A 50 second delay will pass.
3. The overflow light will stop blinking and stay on.
4. The scrub and squeegee functions will be cancelled.

| Operating Mode | Entry Sequence (how to activate) |
|--|--|
| Manual Mode; <i>Manually operate discrete functions without interlocks.</i> | <ol style="list-style-type: none"> 1. Push and hold the ES™ button 2. Turn on the key 3. Hold the ES™ button until the maintenance light comes on. 4. Release the ES™ button 5. To exit--turn off key |

MANUAL MODE:

In this mode, the operator can turn on and off accessories individually and manually. In the manual mode, the operator can turn on accessories without regard to inputs or interlocks. If, for instance, the operator enables the ES™ pump in the manual mode, it will run regardless of whether or not the ES™ float is in the water. What follows is a brief description of each buttons operation in the manual mode.

ES™ :

- *Pressing the ES™ button in the manual mode turns on and off the ES™ pump.*

EDGE SCRUB BUTTON:

- *Pressing the Edge scrub button will extend or retract the scrub head.*

SQUEEGEE BUTTON:

- *Pressing the Squeegee button will turn on the vacuum fan and lower the squeegee. Reverse is ignored.*

ENGINE BUTTON:

- *Pressing the Engine button will toggle the engine between high and low speed.*

SCRUB BUTTON:

- *Pressing the Scrub button will turn on and lower the main scrub head. Holding the Scrub button while scrub is active will cause the down pressures to scroll.*

DETERGENT BUTTON:

- *Pressing and holding the Detergent button will cause the detergent LED's to scroll. If no LED's are on, the detergent pump will be off. If one LED is illuminated, the detergent pump will run in low speed. If both LED's are on, the detergent pump will run at high speed.*

| Operating Mode | Entry Sequence (how to activate) |
|---|--|
| Input Display Mode; <i>Display the state of floats, limit switches, and sensors.</i> | <ol style="list-style-type: none">1. Push and hold the Squeegee button2. Turn on the key3. Hold the Squeegee button until the maintenance light comes on4. Release the Squeegee button5. To exit--turn off key |

INPUT DISPLAY MODE:

In this mode, the operator can observe whether or not inputs to the panel are operating as intended. In the Input Display Mode, the segments of the gas gauge display the state of each input. If an input is open, the controller turns off the segment associated with that input. If an input is shorted to ground, the controller turns on the segment associated with that input.

The operation of the Input Display Mode is as follows:

- **SEGMENT 0** - Rightmost segment of the gas gauge. This segment displays the state of the ES float. This segment will illuminate when this input is shorted to ground.
- **SEGMENT 1** - Second segment from the right of the gas gauge. This segment displays the state of the recovery tank float. This segment will be illuminated when this input is shorted to ground.
- **SEGMENT 2** - Third segment from the right of the gas gauge. This segment displays the state of the reverse input. This segment will be illuminated when this input is shorted to ground.
- **SEGMENT 3** - Forth segment from the right of the gas gauge. This segment displays the state of the sweep sense input. This segment will be illuminated when this input is shorted to ground.
- **ENGINE TEMPERATURE LIGHT** - In the Input Display Mode, the engine temperature light will blink until the engine reaches operating temperature.

| Operating Mode | Entry Sequence (how to activate) |
|---|--|
| Error Display Mode; <i>Display the cause of a self-test failure.</i> | <ol style="list-style-type: none"> 1. Push and hold the Detergent button 2. Turn on the key 3. Hold the Detergent button until the maintenance light comes on. 4. Release the Detergent button |

ERROR DISPLAY MODE

Each time the operator starts the machine, the panel will run a self test on each output. If the panel passes the diagnostic, the "OK" indicator is illuminated. If the panel fails, a code is stored in a non volatile (preserved even after power down) memory. If the machine passes the diagnostic on the next startup cycle, the panel preserves the last failed code. In the Error Display Mode, the operator can obtain the error code stored after the last startup diagnostic failure. When the machine is in this mode, the LED's on the operators panel will indicate which system experienced the failure. If the operator pushes the button associated with an illuminated LED, segments on the gas gauge will indicate which output failed and what type of failure occurred.

The operation of the Error Display Mode is as follows:

ES™ LED

Problem with the ES™ output. If the operator pushes the headlight button in this mode, the panel will display one of the following codes:

- *SEGMENT 0* - Rightmost segment of the gas gauge. This segment would indicate that the ES™ output was shorted to ground when the controller was expecting it to be open.
- *SEGMENT 0, 1* - First and second segments from the right of the gas gauge. These segments would indicate that the ES™ output was open when the controller was trying to short it to ground.

EDGE SCRUB LED

Problem with the edge scrub outputs. If the operator pushes the edge scrub button in this mode the panel would display one of the following codes:

- *SEGMENT 0* - Rightmost segment of the gas gauge. This segment would indicate that the edge scrub output was shorted to ground when the controller was expecting it to be open.
- *SEGMENT 0, 1* - First and second segments from the right of the gas gauge. These segments would indicate that the edge scrub output was open when the controller was trying to short it to ground.

SQUEEGEE LED

Problem with the squeegee actuator or vacuum fan motor outputs. If the operator pushes the squeegee button in this mode, the panel would display one of the following codes:

- *SEGMENT 0* - Rightmost segment of the gas gauge. This segment would indicate that the squeegee actuator output was shorted to ground when the controller was expecting it to be open.
- *SEGMENT 0, 1* - First and second segments from the right of the gas gauge. These segments would indicate that the squeegee actuator output was open when the controller was trying to short it to ground.
- *SEGMENT 2* - Third segment from the right of the gas gauge. This segment would indicate that the vacuum fan motor output was shorted to ground when the controller was expecting it to be open.
- *SEGMENT 2, 3* - Third and fourth segments from the right of the gas gauge. These segments would indicate that the vacuum fan motor output was open when the controller was trying to short it to ground.

SCRUB LED

Problem with the main brush actuator or motor outputs. If the operator pushes the scrub button in this mode, the panel would display one of the following codes:

- *SEGMENT 0* - Rightmost segment of the gas gauge. This segment would indicate that the main brush actuator output was shorted to ground when the controller was expecting it to be open.
- *SEGMENT 0, 1* - First and second segments from the right of the gas gauge. These segments would indicate that the main brush actuator output was open when the controller was trying to short it to ground.
- *SEGMENT 2* - Third segment from the right of the gas gauge. This segment would indicate that the main brush motor output was shorted to ground when the controller was expecting it to be open.
- *SEGMENT 2, 3* - Third and fourth segments from the right of the gas gauge. These segments would indicate that the main brush motor output was open when the controller was trying to short it to ground.

DETERGENT LED

Problem with the headlight or detergent pump outputs. If the operator pushes the detergent button in this mode, the panel would display one of the following codes:

- *SEGMENT 0* - Rightmost segment of the gas gauge. This segment would indicate that the detergent pump output was shorted to ground when the controller was expecting it to be open.
- *SEGMENT 0, 1* - First and second segments from the right of the gas gauge. These segments would indicate that the detergent pump output was open when the controller was trying to short it to ground.

| Operating Mode | Entry Sequence (how to activate) |
|--|--|
| Pressure Adjust Mode; <i>Adjust the pressure levels for the three down pressure settings.</i> | <ol style="list-style-type: none">1. Push and hold the Edge Scrub button2. Turn on the key3. Hold the Edge Scrub button until the maintenance light comes on.4. Release the Edge Scrub button |

PRESSURE ADJUST MODE

When the machine is in this mode, the operator can adjust the down pressures for the main and side brushes. When the operator adjusts down pressure number 3, pressures 1 and 2 are automatically calculated and stored. The operator may make independent adjustments to pressures 1 and 2 after storing number 3. These adjustments will influence only the currently displayed setting.

The operator can change the pressure settings by pressing and holding the scrub button. When the *side brush* is **inactive** and the *main brush* is **active**, the operator can adjust the down pressure for the main brush. When the *side brush* and *main brush* are **active**, the operator can adjust the down pressure for the side brush.

After each adjustment, the new pressure setting is stored in a non-volatile (retained even after power down) memory.

The operation of the Pressure Adjust Mode is as follows:

SCRUB BUTTON

Pressing the Scrub button will start the normal scrub sequence. When scrub is active the following controls and displays take on alternate functions.

- **GAS GAUGE** - The gas gauge in the pressure adjust mode displays the relative down pressure of the main (when the side brush is inactive) or the side brush (when the side brush is active).
- **SQUEEGEE BUTTON** - Holding the squeegee button will **decrease** the down pressure.
- **DETERGENT BUTTON** - Holding the detergent button will **increase** the down pressure.

| Operating Mode | Entry Sequence (how to activate) |
|---|--|
| Reset Scrub Pressures; <i>Return the down pressure settings to the factory defaults.</i> | <ol style="list-style-type: none">1. Push and hold the Scrub button2. Turn on the key3. Hold the Scrub button4. Wait for the maintenance light5. While holding the Scrub button, press and hold the Edge Scrub button6. Wait for the maintenance light to go out7. Release the Scrub and Edge Scrub buttons8. Turn the key off9. Restart the machine |

RESET SCRUB PRESSURES

When the machine goes into this mode, the controller replaces the current brush down pressure settings with factory defaults. To initiate, follow the entry sequence (how to activate). The pressures will automatically reset.

SIDE PANEL OPERATING MODES

The 8410 side panel has a total of four operating modes. When the operator starts the machine the panel will run its self test. If the self test fails, an LED which is associated with the failing system will blink (error display mode). If the operator engages any sweeping functions, the error display mode will cancel and the side panel will run in the normal mode. If the test passes, the side panel will blink the headlights. The main panel will detect the headlight flash, and display a non-blinking OK signal.

Note; The hopper lift LED will blink if Sweep 1 or 2 is selected and the hopper is up.

The following chart will detail each mode and the entry sequence.

| Operating Modes | Entry Sequence (how to activate) |
|---|---|
| Normal Mode; <i>Normal operation.</i> More info pages 5-46 thru 5-49 | Default (when key is turned on) |
| Manual Mode; <i>Manually operate discrete functions without interlocks.</i> More info pages 5-50 and 5-51 | <ol style="list-style-type: none">1. Push and hold the Hazard light button.2. Turn on the key3. Hold the Hazard light button for 10 seconds. comes on.4. Release the Hazard light button. The Hazard light should begin to blink.5. To exit--turn off key |
| Input Display Mode; <i>Display the state of floats, limit switches, and sensors.</i> More info page 5-52 | <ol style="list-style-type: none">1. Push and hold the Headlight button.2. Turn on the key3. Hold the Headlight button for 10 seconds.4. Release the Headlight button. The sweep 1 and sweep 2 lights will be on.5. To exit--turn off key |
| Error Display Mode; <i>Display the cause of a self test failure.</i> More info page 5-53 | If an error is detected, the side panel will automatically go into the error display mode. When a function from the side panel is selected, the panel will go into the normal mode. |

| Operating Mode | Entry Sequence (how to activate) |
|---------------------------------------|-------------------------------------|
| Normal Mode; <i>Normal operation.</i> | Default (when key is turned on) |

NORMAL MODE

The purpose of the normal mode is for the general operation of the machine. The machine will normally start in this mode. What follows is a brief description of each buttons operation in the normal mode.

HAZARD LIGHTS:

- *Pressing the Hazard light button will toggle on and off the Hazard lights.*

HEAD LIGHTS:

- *Pressing the Head light button will toggle on and off the Head lights.*

FILTER SHAKER:

- *The Filter shaker button controls the operation of the filter shaker and timer system.*
- If the Filter shaker LED is **OFF**, pressing the shaker button will initiate a shake sequence. A shake sequence is defined as follows:
 1. The Shaker LED will turn on.
 2. The filter shaker will start.
 3. The filter shaker and LED will remain on for approximately 40 seconds.
 4. The filter shaker and LED will turn off.
- If the Filter shaker LED is **ON**, pressing the shaker button will turn off the shaker motor and LED.
- A 15 second shake sequence will also be initiated each time the sweep system is turned off.
- A shake sequence will be cancelled if active while the sweep, or sweep vacuum fan is turned on.

HOPPER LIFT:

- *Pressing and holding the Hopper lift button will engage the hopper lift mechanism. The Hopper will continue to lift as long as the operator holds his finger on the Hopper lift button.*

Note; The hopper lift LED will blink if Sweep 1 or 2 are selected and the hopper is up.

HOPPER LOWER:

- *Pressing and holding the Hopper lower button will engage the hopper lower mechanism. The Hopper will continue to drop as long as the operator holds his finger on the Hopper lower button.*

HOPPER DOOR:

- *Pressing the Hopper door button will toggle the hopper door open or closed.*
- **If the Hopper door LED is lit**, the hopper door is *closed*. Pressing the Hopper door button will turn off the LED and open the door for 3 seconds.
- **If the Hopper door LED is not lit**, the hopper door is *open*. Pressing the Hopper door button will turn on the LED and close the door for 3 seconds.
- The Hopper door will automatically open each time the sweep function is engaged.
- The Hopper door will automatically close each time the machine is started, or the sweep function is turned off.

SIDE BRUSH:

- *Pressing the Side Brush button will enable or disable the side brush operation while sweeping.*
- The Side brush will only operate if the Sweep function is engaged.
- Each time the Sweep function is engaged, the side brush will be enabled.
- Each time the Sweep function is turned off, the Side brush will be canceled.

VACUUM FAN:

- *Pressing the Sweep Vacuum Fan button will enable or disable the fan operation while sweeping.*
- The Sweep fan will only operate if the Sweep function is engaged.
- Each time the Sweep function is engaged, the fan will be enabled.
- Each time the Sweep function is turned off, the fan will be canceled.

SWEEP 1 (NORMAL SWEEP):

- *The **Sweep 1** button is used to engage and disengage the normal sweep functions. **Sweep 1** can only be engaged if the hopper is in the down position. If the hopper is not in the down position and the **Sweep 1** button is pushed, the Sweep system will not be engaged, and the hopper up light will begin to blink.*

- **If the Sweep 1 and 2 LED's are not lit** (Sweep not currently active), pressing the Sweep 1 button will engage the following sweep sequence:

1. The controller will check the hopper down switch. If the hopper down switch is not engaged, the sweep function will be canceled. If the hopper down switch is engaged, the following sequence will continue:
2. The hopper door will begin to open.
3. After the hopper door opens, the sweep fan will turn on.
4. The side brush will turn on.
5. The engine will be set to its high operating speed.
6. The main broom will turn on in normal speed.

- **If the Sweep 1 LED is lit** (Sweep currently active), pressing the Sweep 1 button will disengage the sweep system with the following sequence:

1. The main broom, side brush, and sweep fan will turn off.
2. The hopper door will close.
3. A filter shake sequence will begin.

SWEEP 2 (LITTER SWEEP):

- The **Sweep 2** button is used to engage and disengage the litter sweep functions. The litter sweep function can only be engaged if the scrub system is turned off. Pressing the **Sweep 2** button while the scrub function is enabled will engage the Sweep 1 system. **Sweep 1** can only be engaged if the hopper is in the down position. If the hopper is not in the down position and the **Sweep 1** button is pushed, the Sweep system will not be engaged, and the hopper up light will begin to blink.

- **If the Sweep 1 and 2 LED's are not lit** (Sweep not currently active), pressing the Sweep 2 button will engage the following sweep sequence:

1. The controller will check the hopper down switch. If the hopper down switch is not engaged, the sweep function will be canceled. If the hopper down switch is engaged, the following sequence will continue:
2. The hopper door will begin to open.
3. After the hopper door opens, the sweep fan will turn on.
4. The side brush will turn on.
5. The engine will be set to its high operating speed.
6. The main broom will turn on in litter speed.

- **If the Sweep 2 LED is lit** (Sweep currently active), pressing the Sweep 2 button will disengage the sweep system with the following sequence:

1. The main broom, side brush, and sweep fan will turn off.
2. The hopper door will close.
3. A filter shake sequence will begin.

| Operating Mode | Entry Sequence (how to activate) |
|--|---|
| Manual Mode; <i>Manually operate discrete functions without interlocks.</i> | <ol style="list-style-type: none"> 1. Push and hold the Hazard light button. 2. Turn on the key 3. Hold the Hazard light button for 10 seconds. comes on. 4. Release the Hazard light button. The Hazard light should begin to blink. 5. To exit--turn off key |

MANUAL MODE

In this mode, the operator can turn on and off accessories individually and manually. In the manual mode, the operator can turn on accessories without regard to inputs or interlocks. If, for instance, the operator enables the sweep vacuum fan in the manual mode, it will run regardless of whether or not the sweep function is engaged or the hopper down switch is closed. What follows is a brief description of each buttons operation in the manual mode.

HAZARD LIGHT:

- *Same as normal operation.*

HEAD LIGHT:

- *Same as normal operation.*

FILTER SHAKER:

- *Toggles on and off the filter shaker motor. Timer is disabled.*

HOPPER UP:

- *Same as normal operation.*

HOPPER DOWN:

- *Same as normal operation.*

HOPPER DOOR:

- *Same as normal operation.*

SIDE BRUSH:

- *Toggles on and off the side brush. Side brush will run regardless of whether or not sweeping is engaged.*

SWEEP FAN:

- *Toggles on or off the sweep fan. Fan will run regardless of the state of sweep or hopper down switch. Sweep 1 or Sweep 2 must be engaged.*

SWEEP 1:

- *Toggles on or off main broom in normal speed. Broom will run regardless of the state of the hopper down switch.*

SWEEP 2:

- *Toggles on or off main broom in litter speed. Broom will run regardless of the state of the hopper down switch.*

| Operating Mode | Entry Sequence (how to activate) |
|---|--|
| Input Display Mode; <i>Display the state of floats, limit switches, and sensors.</i> | 1. Push and hold the Headlight button. 2. Turn on the key 3. Hold the Headlight button for 10 seconds. 4. Release the Headlight button. The sweep 1 and sweep 2 lights will be on simultaneously. 5. To exit--turn off key |

INPUT DISPLAY MODE:

In this mode, the side panel will display the state of the external switches (i.e. hopper down switch) or functions which are used as interlocks. In this mode, the function of the switch LED's changes from indicating the state of an operation (like the hopper door is closed), to indicating the state of a sensor (like the hopper down switch). The technician can use this mode to check the state of various sensors on the machine.

The operation of the Input Display Mode is as follows:

BLINKING HAZARD LED:

- *Hopper thermal switch is open.*

BLINKING SHAKER LED:

- *Reverse switch is closed.*

BLINKING HOPPER DOOR LED:

- *Hopper down switch is open.*

BLINKING SIDE BRUSH LED:

- *Scrub signal is low (active).*

BLINKING HEAD LIGHT LED:

- *Engine is in high speed.*

| Operating Mode | Entry Sequence (how to activate) |
|---|---|
| Error Display Mode; <i>Display the cause of a self test failure.</i> | If an error is detected, the side panel will automatically go into the error display mode. When a function from the side panel is selected, the panel will go into the normal mode. |

ERROR DISPLAY MODE

If the 8410 side panel fails its initial self test, this mode is designed to give the service person a clue as to the cause of the failure. The 8410 side panel will automatically go into this mode when a failure is detected. To cancel the error display mode, the operator can press any button on the side panel. Once a button has been pushed, normal operation will resume.

The operator can identify errors detected during self test using blinking LED's on the side panel. The assignments between LED's and failures are as follows:

BLINKING SHAKER LED:

- *Failure on shaker output.*

BLINKING HAZARD LED:

- *Failure on hazard light or reverse output.*

BLINKING HEADLIGHT LED:

- *Failure on headlight output.*

BLINKING SIDE BRUSH LED:

- *Failure on side brush output.*

BLINKING HOPPER DOOR LED:

- *Failure on hopper door open or close output.*

BLINKING HOPPER UP LED:

- *Failure on hopper raise output.*

BLINKING HOPPER DOWN LED:

- *Failure on hopper lower output.*

BLINKING SWEEP FAN LED:

- *Failure on sweep fan or engine fan output.*

BLINKING SWEEP 1 LED:

- *Failure on Sweep 1 or brush down output.*

BLINKING SWEEP 2 LED:

- *Failure on Sweep 2 or output.*

TROUBLESHOOTING

The following troubleshooting section is organized with the section of the electrical schematic that pertains to that particular problem first, followed by the flow chart.

**INSTRUMENT PANEL
DOES NOT POWER UP
(SCHEMATIC)**

OPERATION:
 -KEY SWITCH ACTIVATES M3, M4, AND M5
 -M3, M4, AND M5 CONTACTS SUPPLY B+
 TO INSTRUMENT PANEL (PIN 1 AND 2)

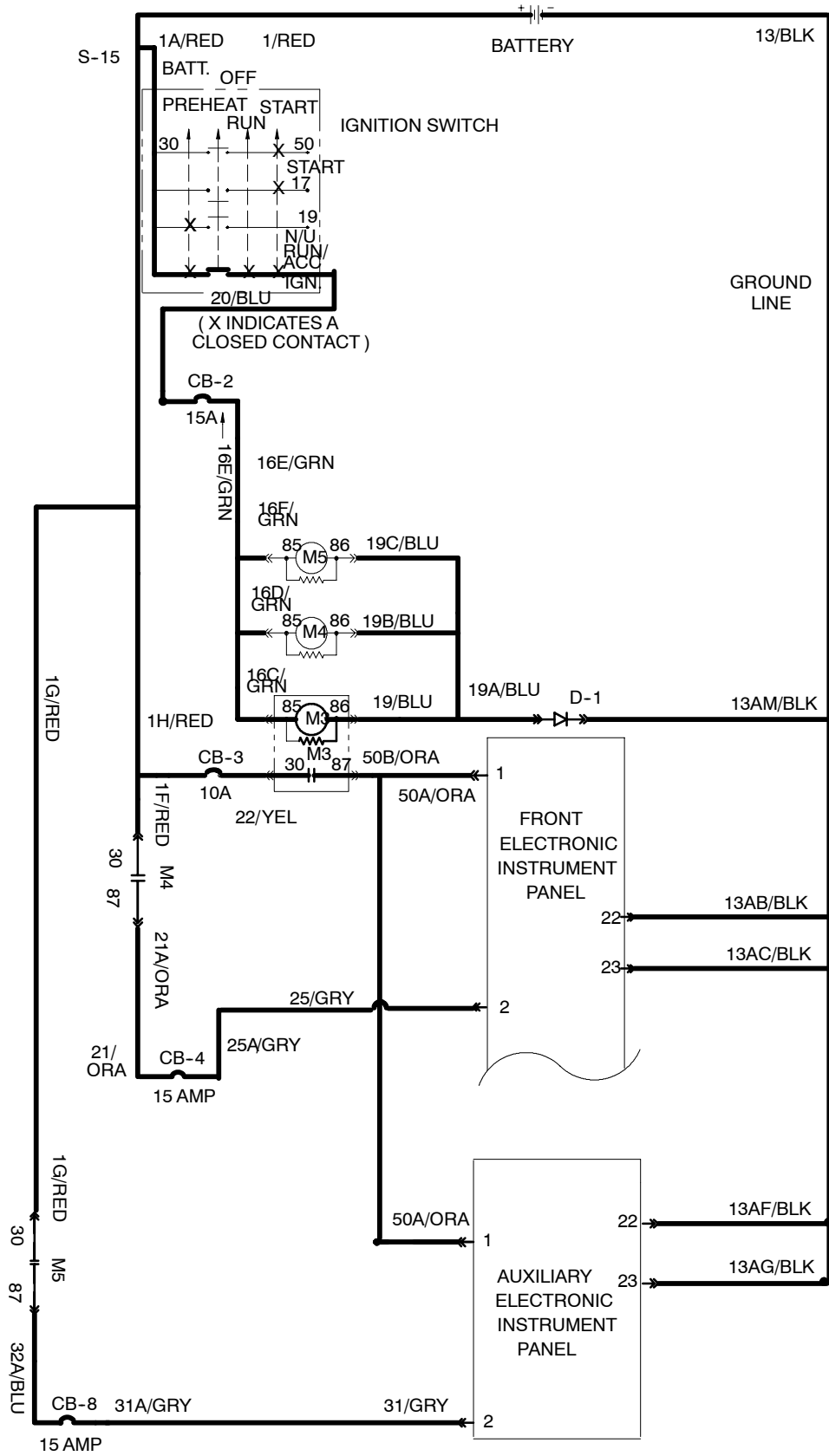

INSTRUMENT PANEL DOES NOT POWER UP (FLOW CHART)

OPERATION:
 -KEY SWITCH ACTIVATES M3, M4, AND M5
 -M3, M4, AND M5 CONTACTS SUPPLY B+ TO INSTRUMENT PANEL (PIN 1 AND 2)

TURN KEY ON
 ENGINE NEED NOT BE RUNNING

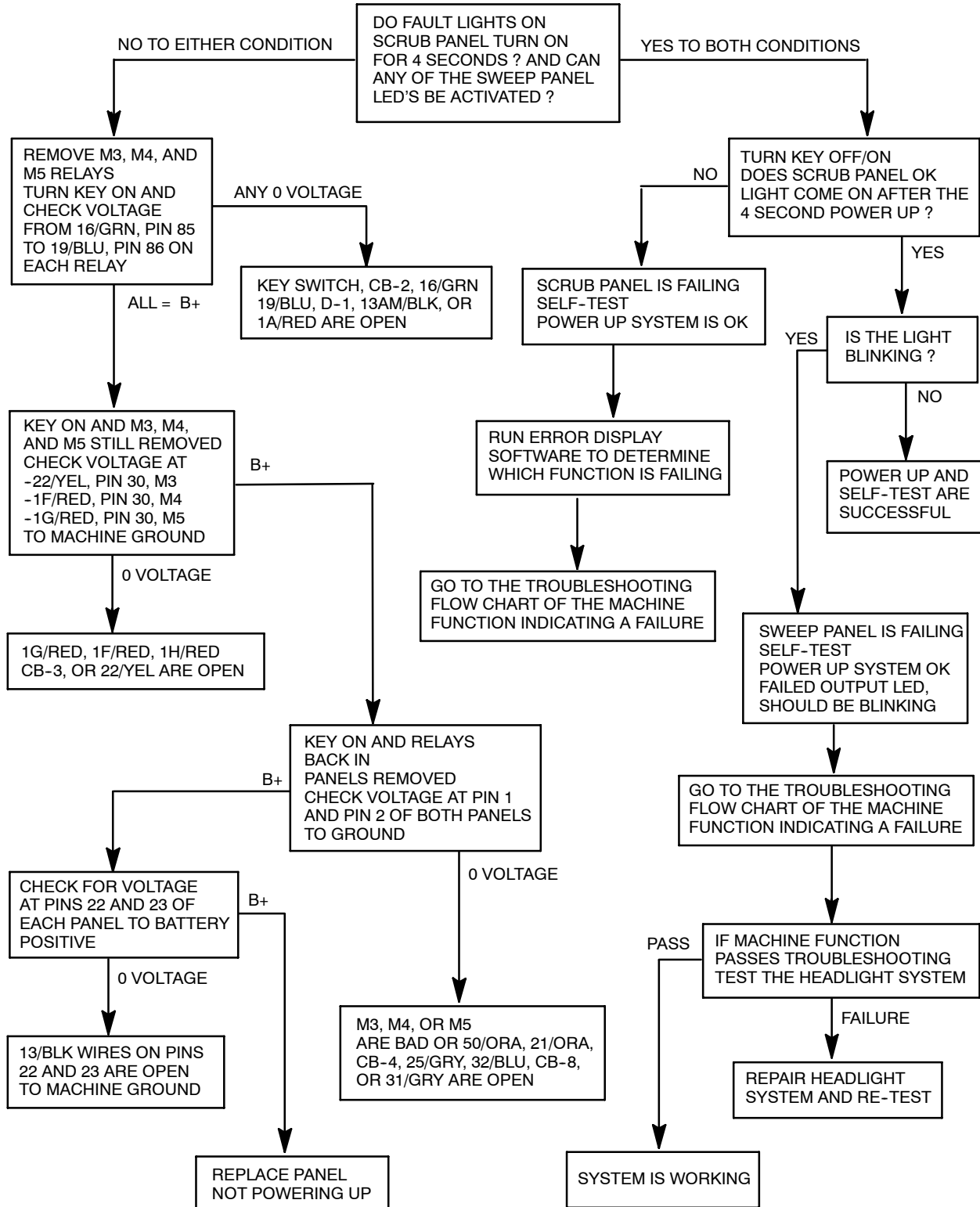

**SCRUB BRUSH WILL NOT
TURN ON AND/OR DOWN
(SCHEMATIC)**

OPERATION:
 -SCRUB IS SELECTED ON TOUCH PANEL
 -MACHINE IS NOT IN REVERSE
 -RECOVERY TANK IS NOT FULL
 -ENGINE SPEED IS SELECTED TO HIGH
 -SCRUB SOLENOIDS WILL TURN ON,
 HEAD WILL LOWER, BRUSHES WILL SPIN

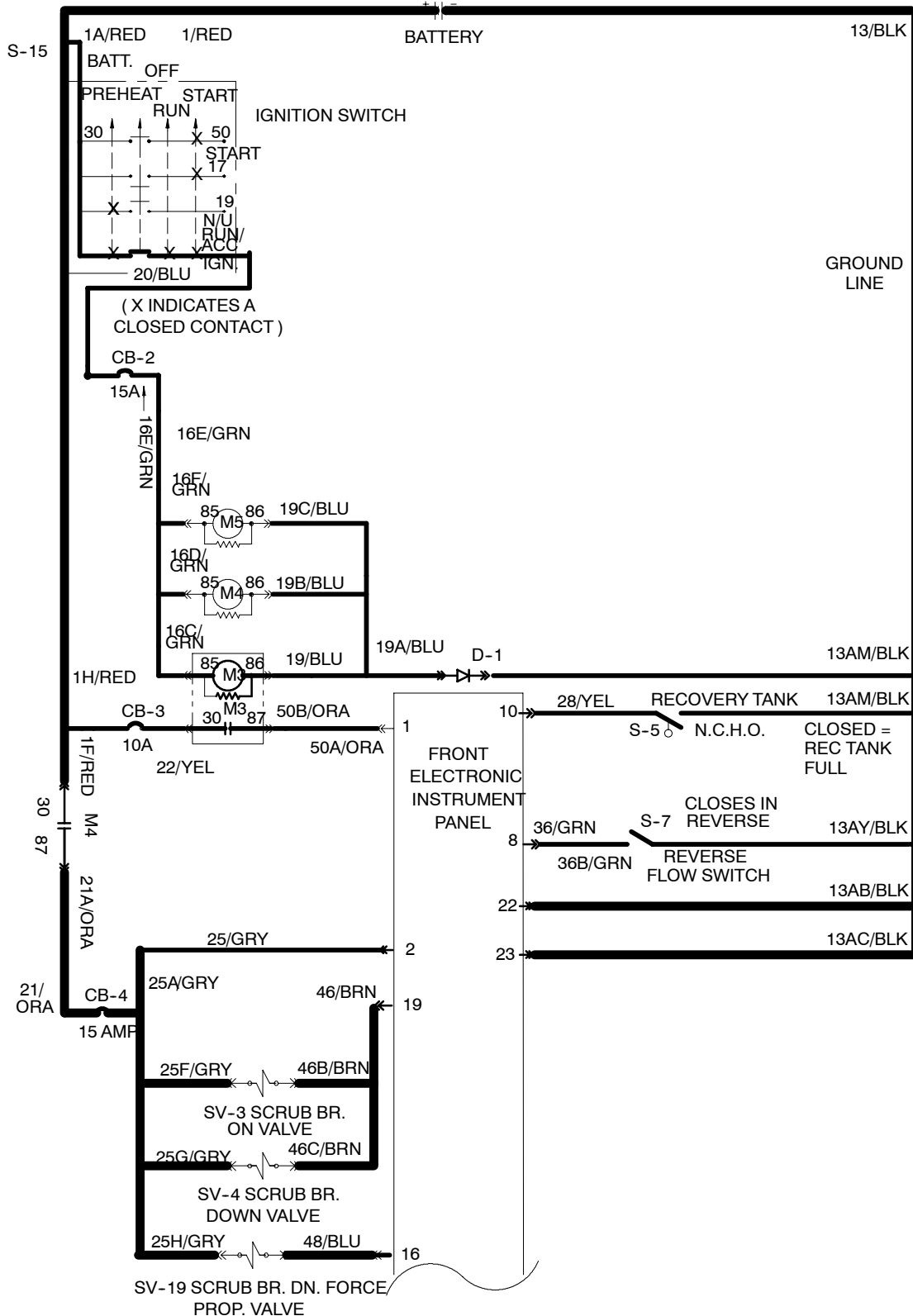

SCRUB BRUSH WILL NOT TURN ON AND/OR DOWN (FLOW CHART)

BOTH PANELS ARE POWERED UP
KEY IS ON
ENGINE IS OFF

OPERATION:
-SCRUB IS SELECTED ON TOUCH PANEL
-MACHINE IS NOT IN REVERSE
-RECOVERY TANK IS NOT FULL
-ENGINE SPEED IS SELECTED TO HIGH
-SCRUB SOLENOIDS WILL TURN ON
-HEAD WILL LOWER
- BRUSHES WILL SPIN

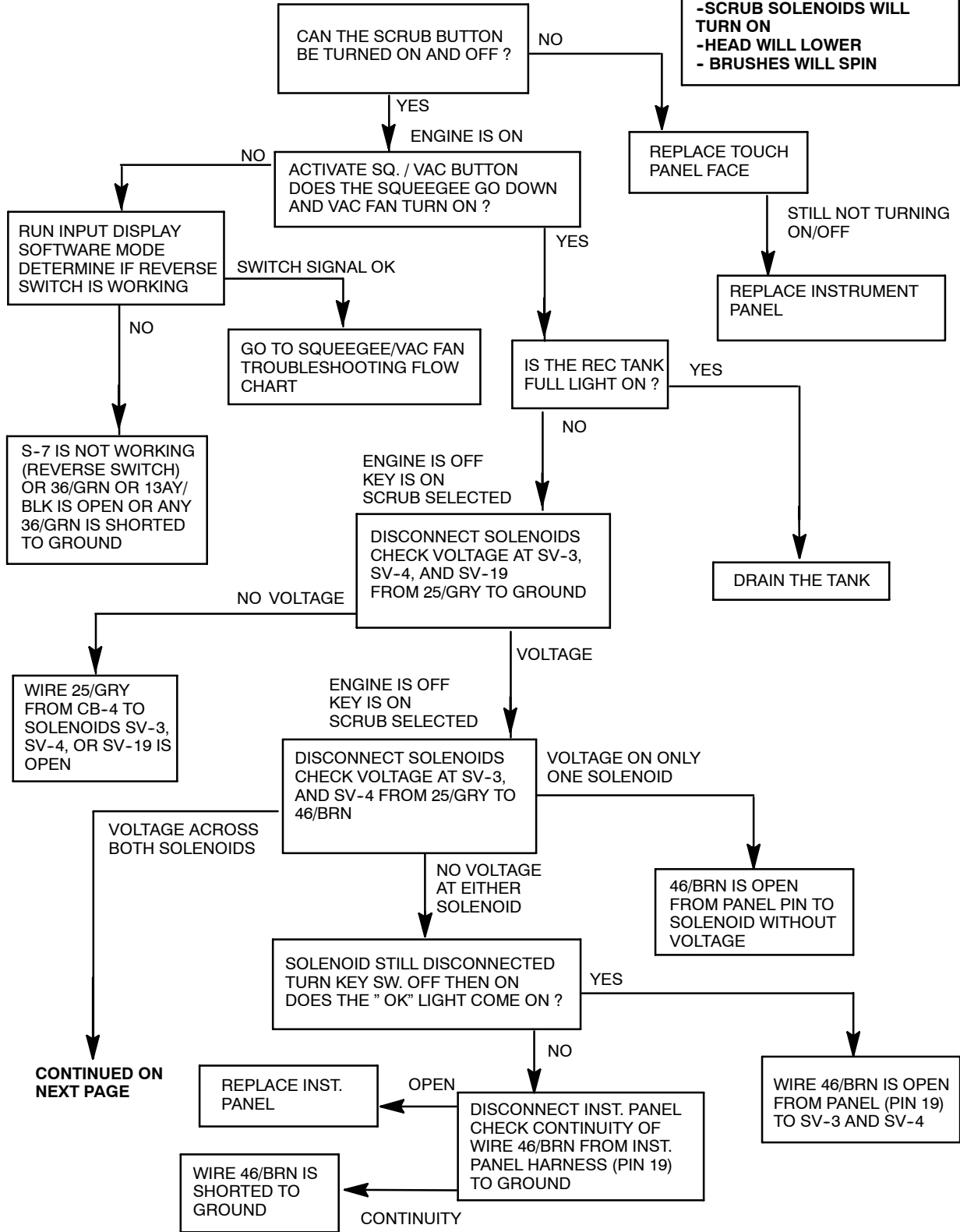

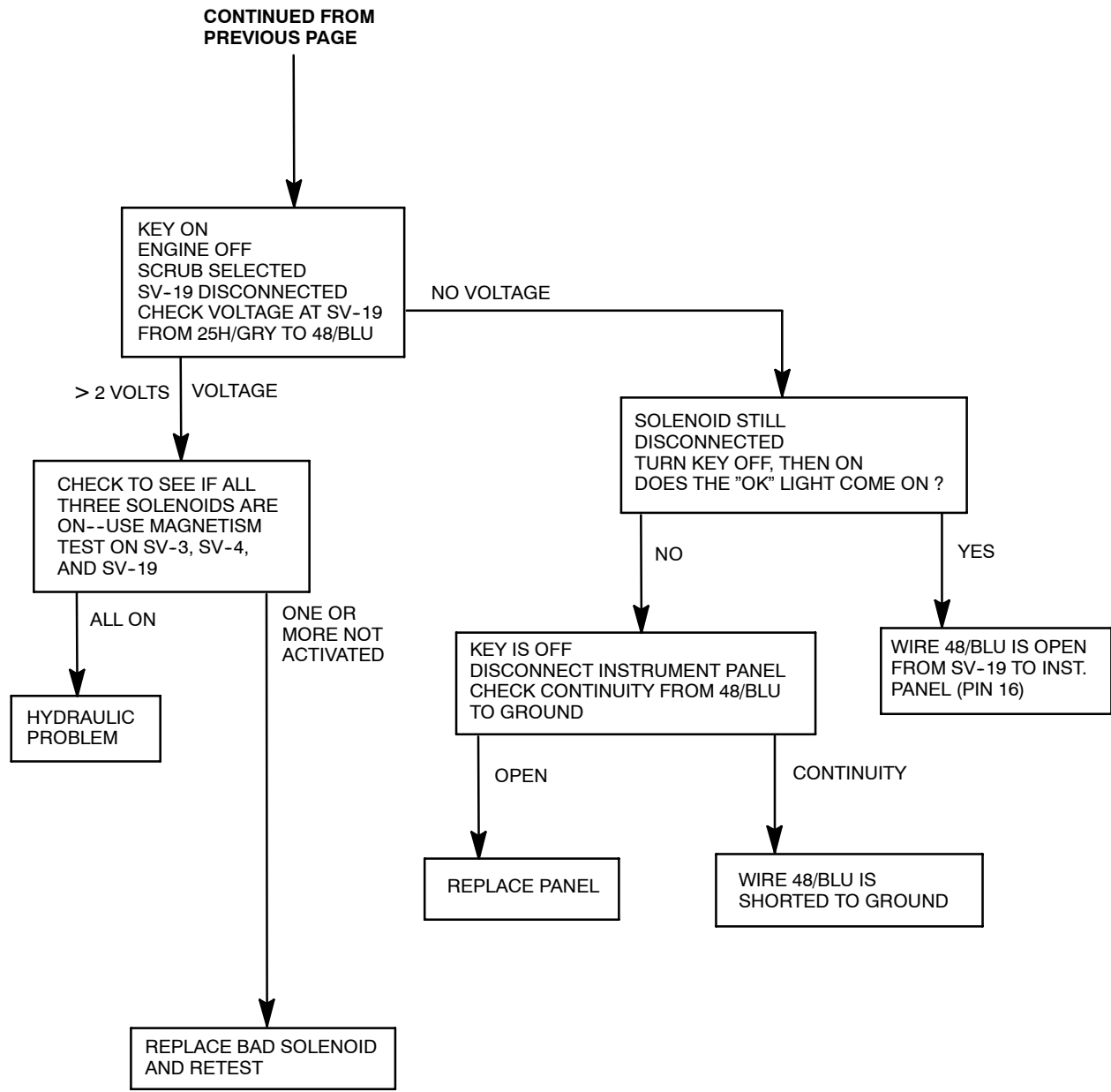

**SCRUB HEAD WILL NOT EXTEND
(SCHEMATIC)**

OPERATION:
 -MACHINE MUST BE IN SCRUB MODE
 -EDGE SCRUB BUTTON IS ACTIVATED
 -MACHINE NOT IN REVERSE
 -ENGINE SPEED ON HIGH
 -SV-10 IS TURNED ON
 -THE SCRUB HEAD WILL EXTEND

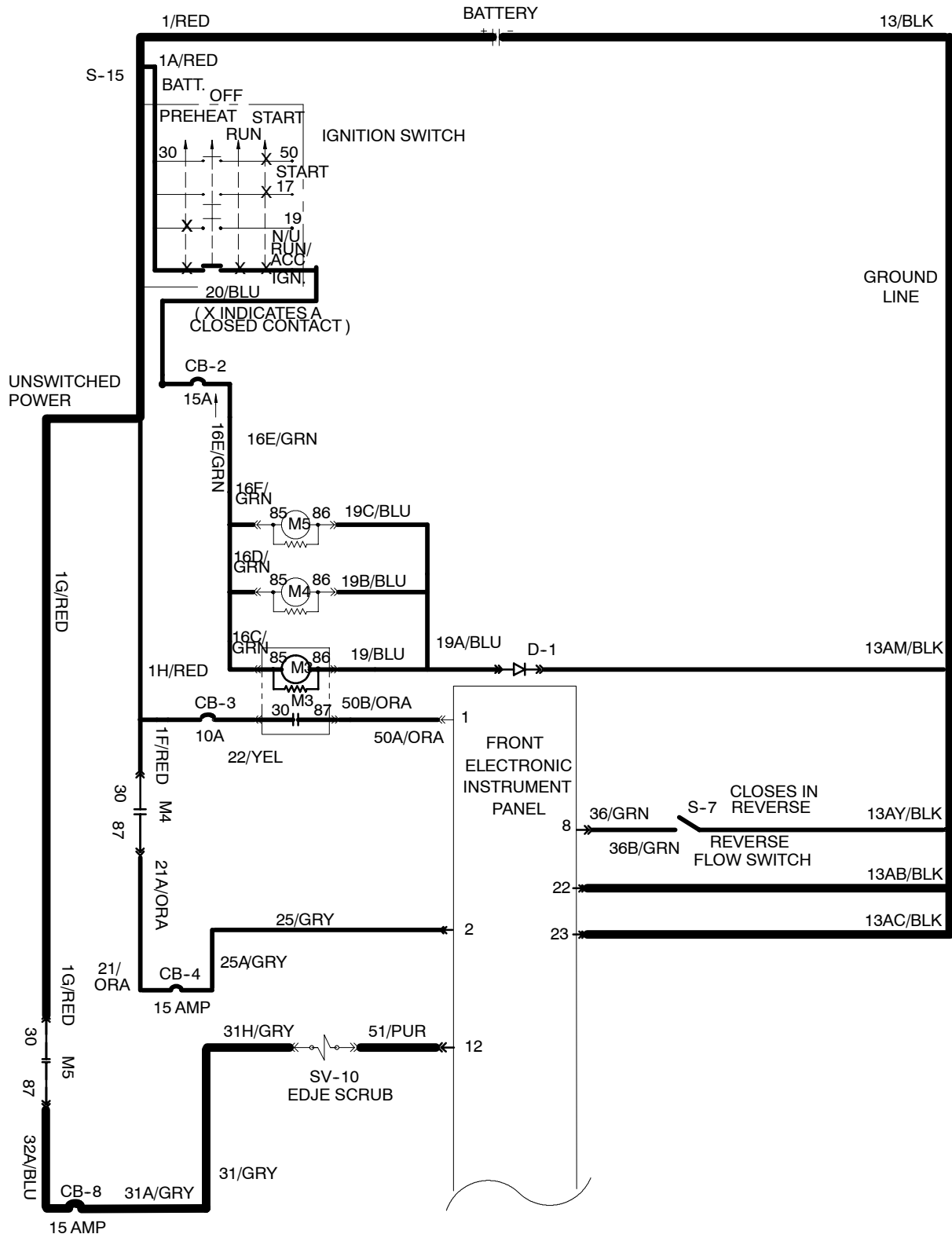

**SCRUB HEAD WILL NOT EXTEND
(FLOW CHART)**

OPERATION:
 -MACHINE MUST BE IN SCRUB MODE
 -EDGE SCRUB BUTTON IS ACTIVATED
 -MACHINE NOT IN REVERSE
 -ENGINE SPEED ON HIGH
 -SV-10 IS TURNED ON
 -THE SCRUB HEAD WILL EXTEND

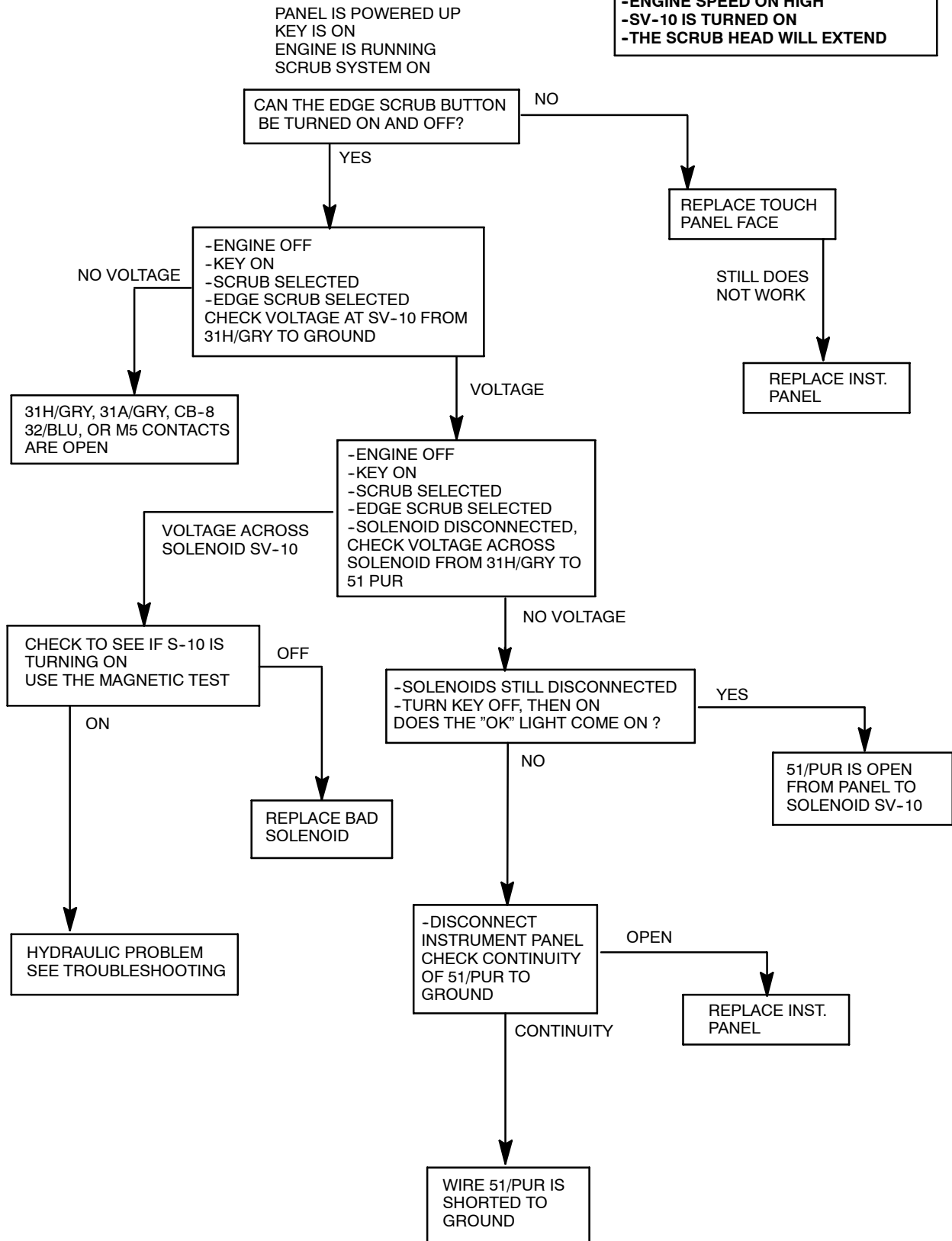

SQUEEGEE AND VACUUM FAN NOT TURNING ON AND GOING DOWN (SCHEMATIC)

OPERATION:
 -SQ/VAC IS SELECTED ON TOUCH PANEL
 -MACHINE NOT IN REVERSE
 -ENGINE SPEED HIGH
 -NO OVERFLOW CONDITION SENSED
 -THE SQUEEGEE LOWERS AND SCRUB VACUUM FAN TURNS ON

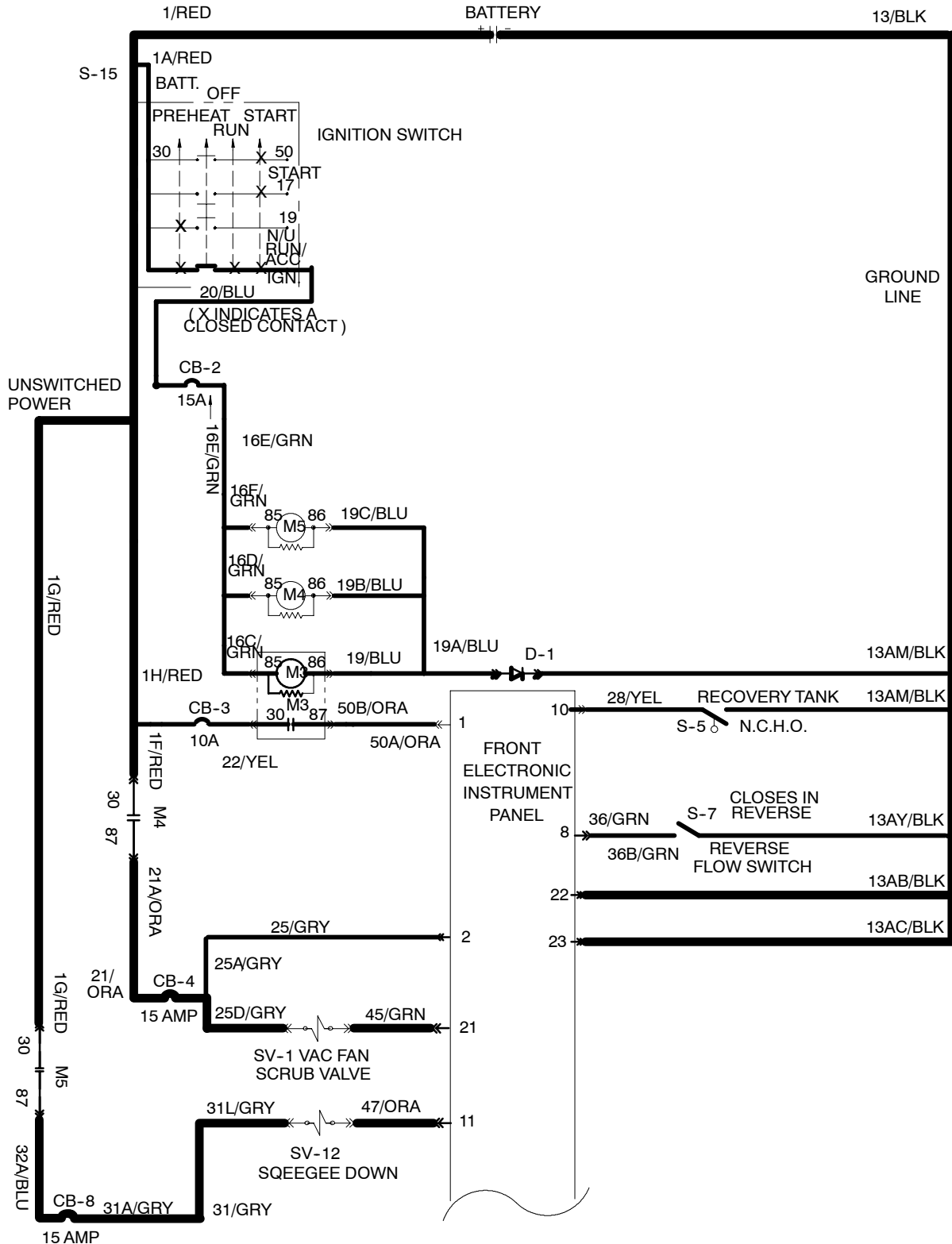

SQUEEGEE AND VACUUM FAN NOT TURNING ON AND GOING DOWN (FLOW CHART)

PANEL IS POWERED UP
KEY IS ON
ENGINE IS RUNNING

OPERATION:
-SQ/VAC IS SELECTED ON TOUCH PANEL
-MACHINE NOT IN REVERSE
-ENGINE SPEED HIGH
-NO OVERFLOW CONDITION SENSED
-THE SQUEEGEE LOWERS AND SCRUB VACUUM FAN TURNS ON

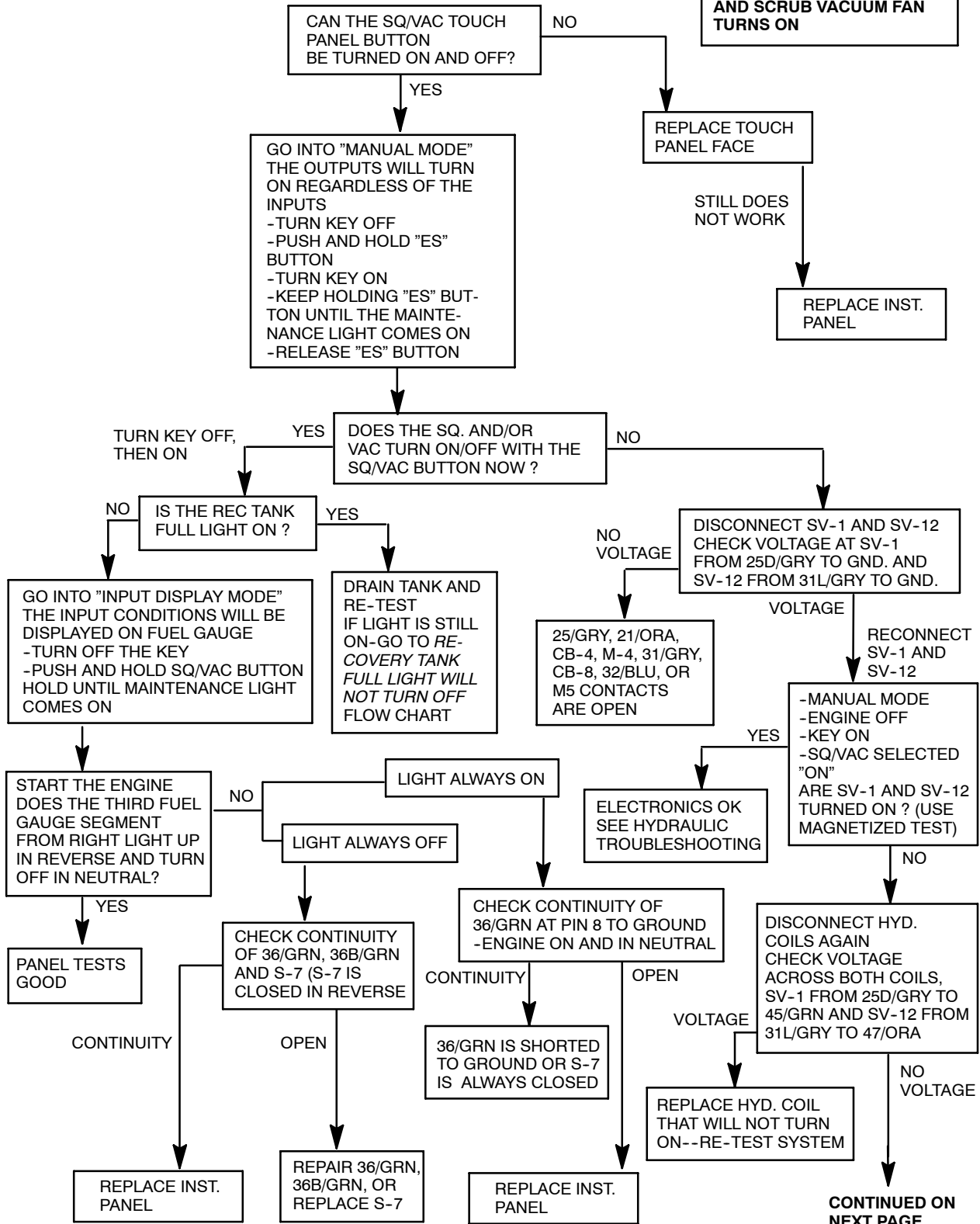

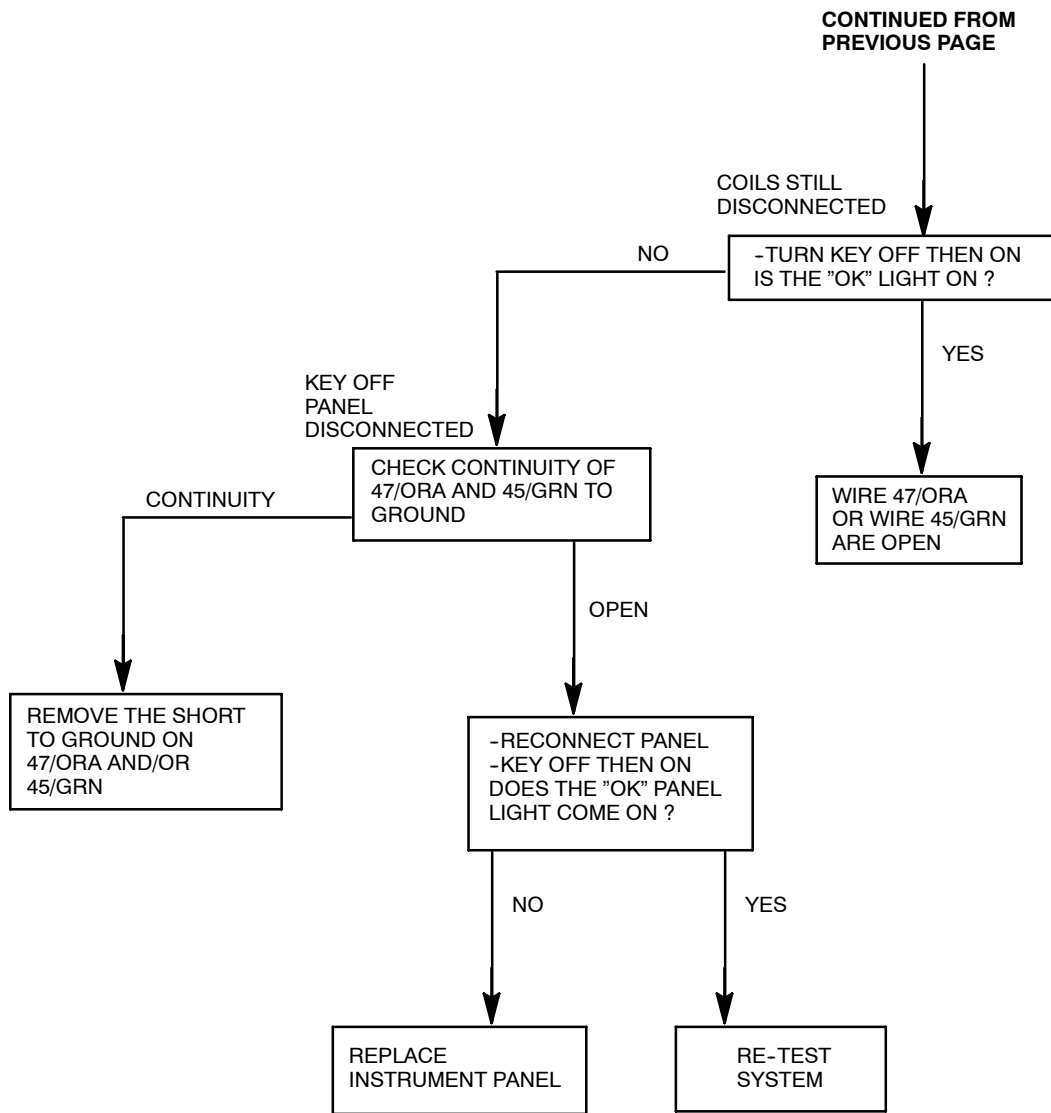

WATER VALVES NOT OPERATING (SCHEMATIC)

OPERATION:
 -SCRUB FUNCTIONS MUST BE ON
 -WATER SWITCH IN POSITION #1 TURNS ON SV-21 LOW WATER VALVE
 -WATER SWITCH IN POSITION #2 TURNS ON SV-21 AND SV-22 (HIGH WATER VALVE)

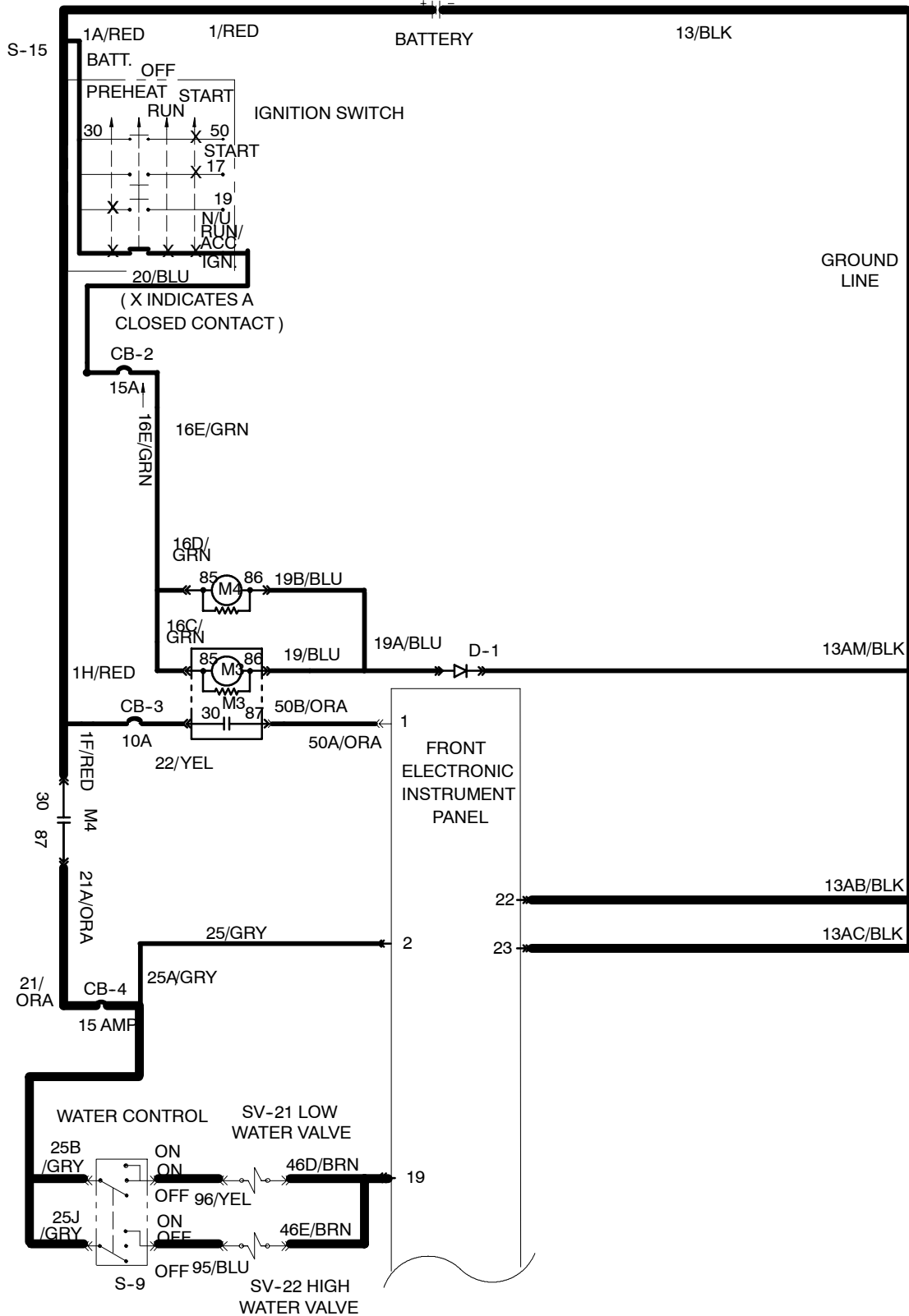

**WATER VALVES NOT OPERATING
(FLOW CHART)**

OPERATION:
 -SCRUB FUNCTIONS MUST BE ON
 -WATER SWITCH IN POSITION #1 TURNS ON SV-21 LOW WATER VALVE
 -WATER SWITCH IN POSITION #2 TURNS ON SV-21 AND SV-22 (HIGH WATER VALVE)

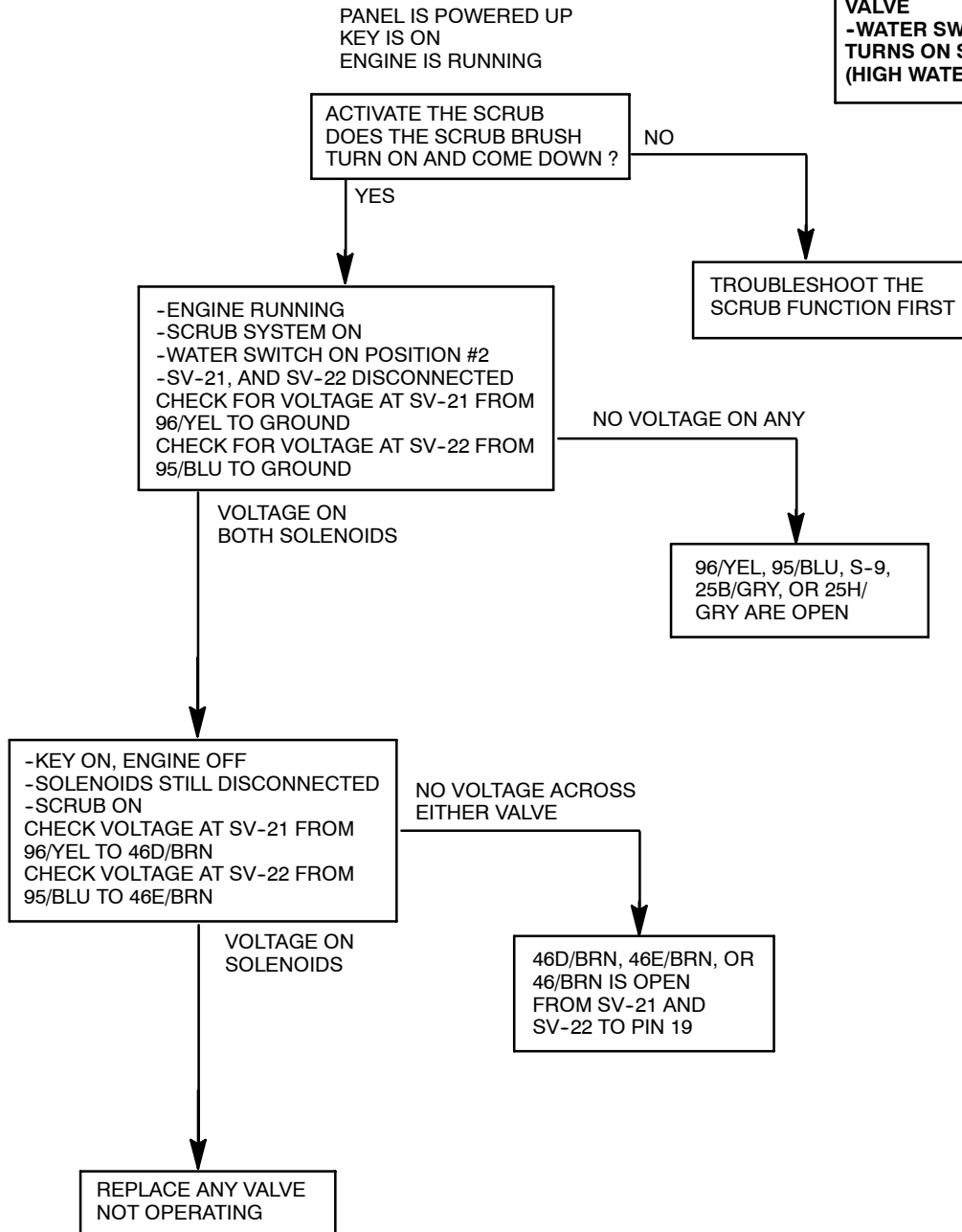

**RECOVERY TANK FULL LIGHT
WILL NOT TURN ON OR OFF
(SCHEMATIC)**

OPERATION:
 -IF S-5 CLOSES, THE RECOVERY TANK IS FULL
 -THE RECOVERY TANK LIGHT COMES ON
 -SCRUB , SQUEEGEE, AND VACUUM FAN TURNS OFF

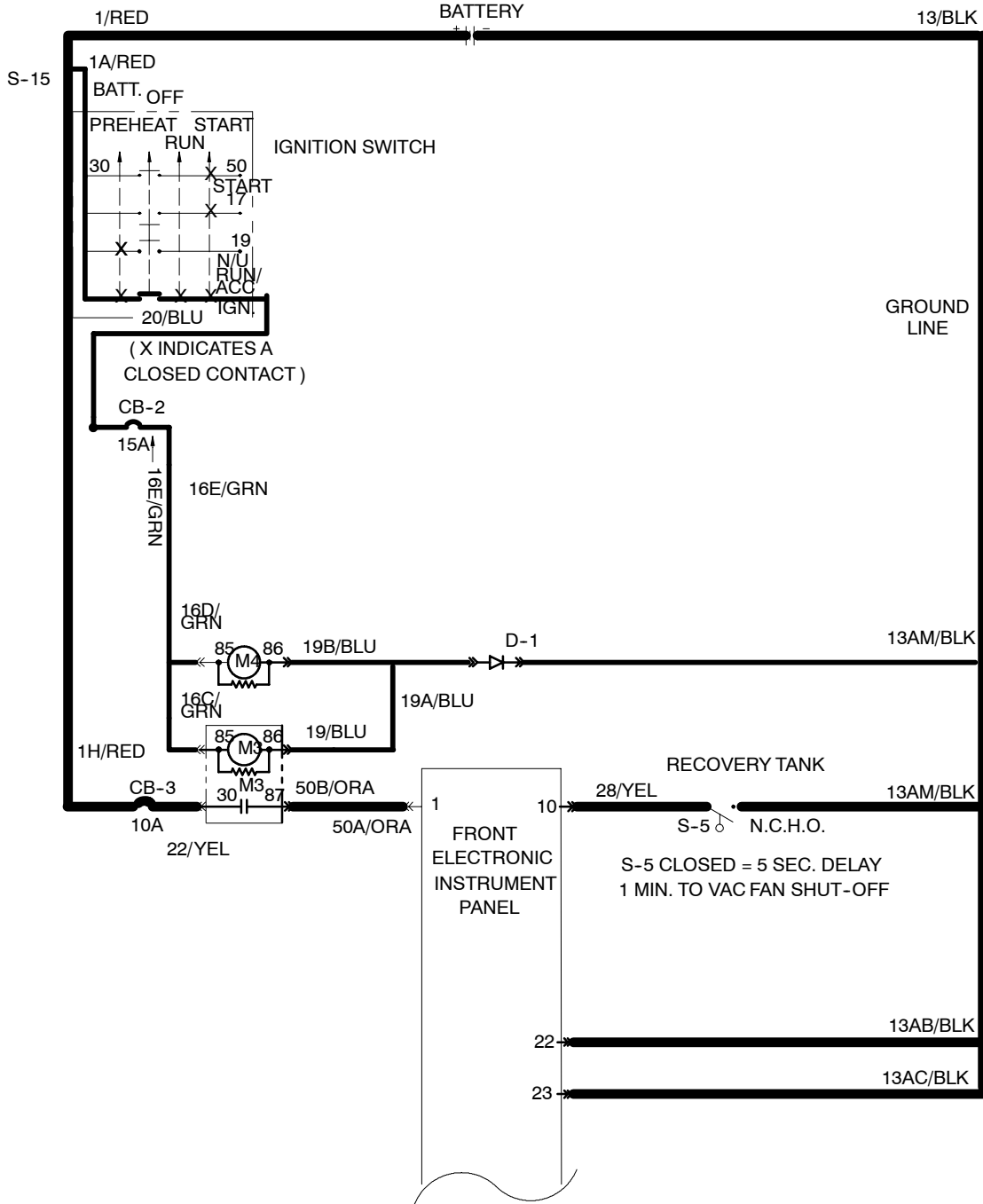

**RECOVERY TANK FULL LIGHT
WILL NOT TURN ON
(FLOW CHART)**

OPERATION:
 -IF S-5 CLOSES, THE RECOVERY TANK IS FULL
 -THE RECOVERY TANK LIGHT COMES ON
 -SCRUB , SQUEEGEE, AND VACUUM FAN TURN OFF

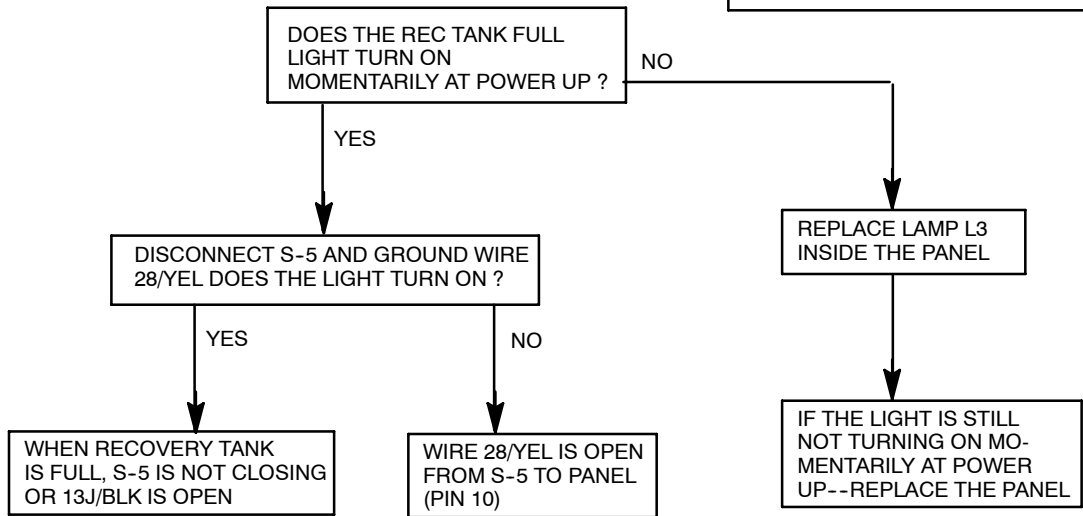

**RECOVERY TANK FULL LIGHT
WILL NOT TURN OFF
(FLOW CHART)**

OPERATION:
 -IF S-5 CLOSES, THE RECOVERY TANK IS FULL
 -THE RECOVERY TANK LIGHT COMES ON
 -SCRUB , SQUEEGEE, AND VACUUM FAN TURNS OFF
 -SELECTING SQUEEGEE/VAC FAN OR TURNING KEY OFF, THEN ON WILL TURN LIGHT OFF IF REC TANK IS NO LONGER FULL

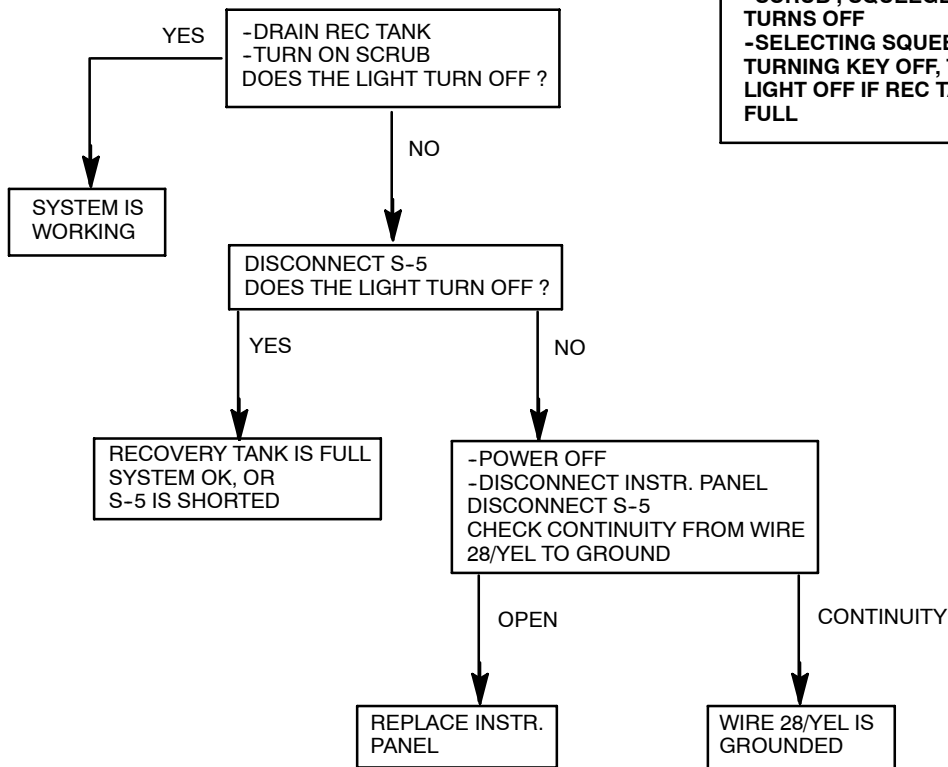

**DETERGENT METERING
PUMP IS NOT OPERATING
(SCHEMATIC)**

OPERATION:
 -PANEL DETERGENT BUTTON IS ACTIVE IN LOW OR HIGH POSITION
 -MACHINE IS IN SCRUB MODE
 -MACHINE IS NOT IN REVERSE
 -DETERGENT PUMP WILL BE TURNED ON WITH A PULSE WIDTH MODULATED SIGNAL

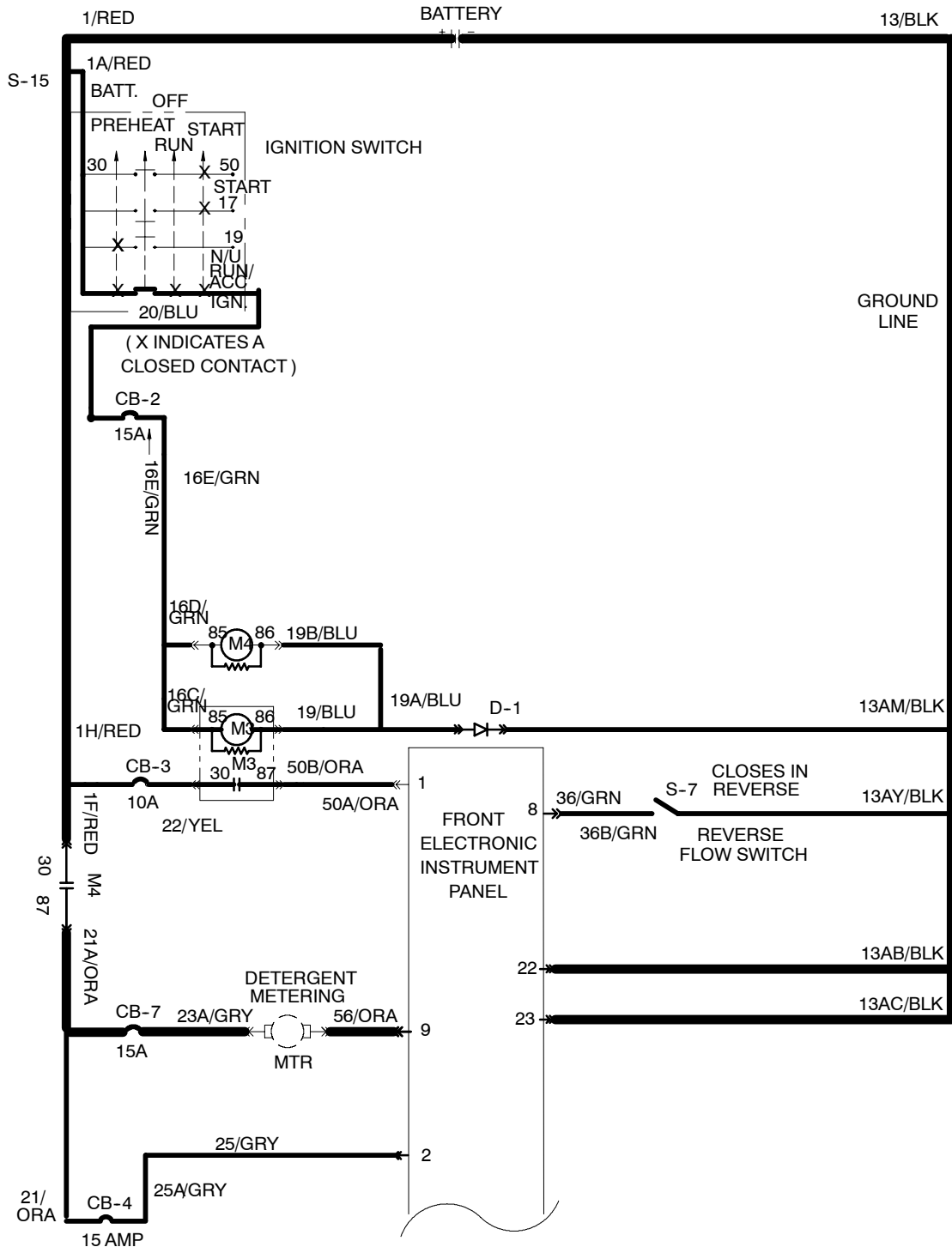

DETERGENT METERING PUMP IS NOT OPERATING (FLOW CHART)

OPERATION:
 -PANEL DETERGENT BUTTON IS ACTIVE IN LOW OR HIGH POSITION
 -MACHINE IS IN SCRUB MODE
 -MACHINE IS NOT IN REVERSE
 -DETERGENT PUMP WILL BE TURNED ON WITH A PULSE WIDTH MODULATED SIGNAL

PANEL IS POWERED UP
 KEY IS ON

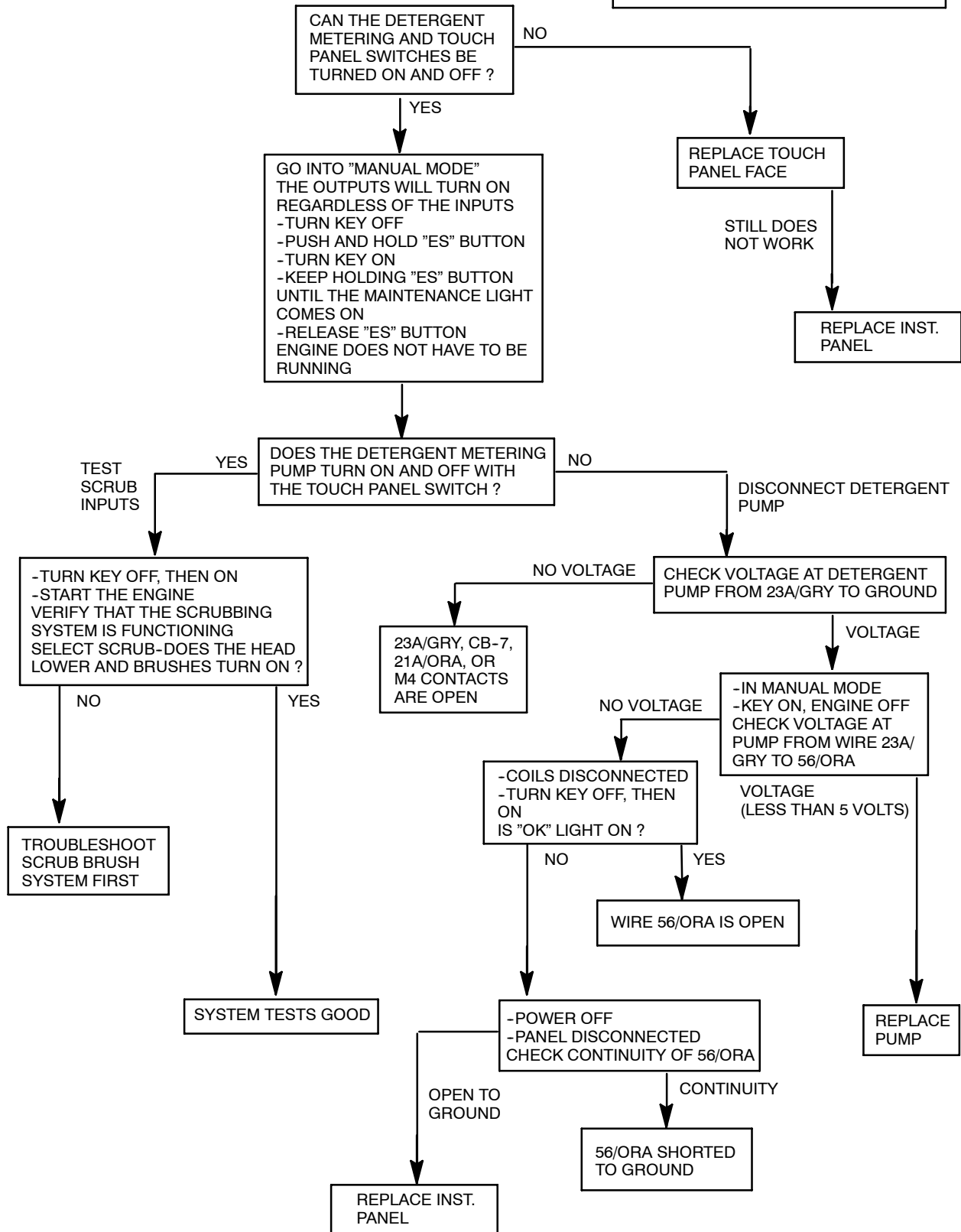

**ES™ PUMP NOT WORKING
(SCHEMATIC)**

OPERATION:
 -IF ES IS SELECTED ON PANEL AND
 -S-3 AND S-4 CLOSE FOR 10 SECONDS
 -THE ES PUMP WILL RUN UNTIL S-3 OR
 S-4 OPENS PLUS 40 SECONDS

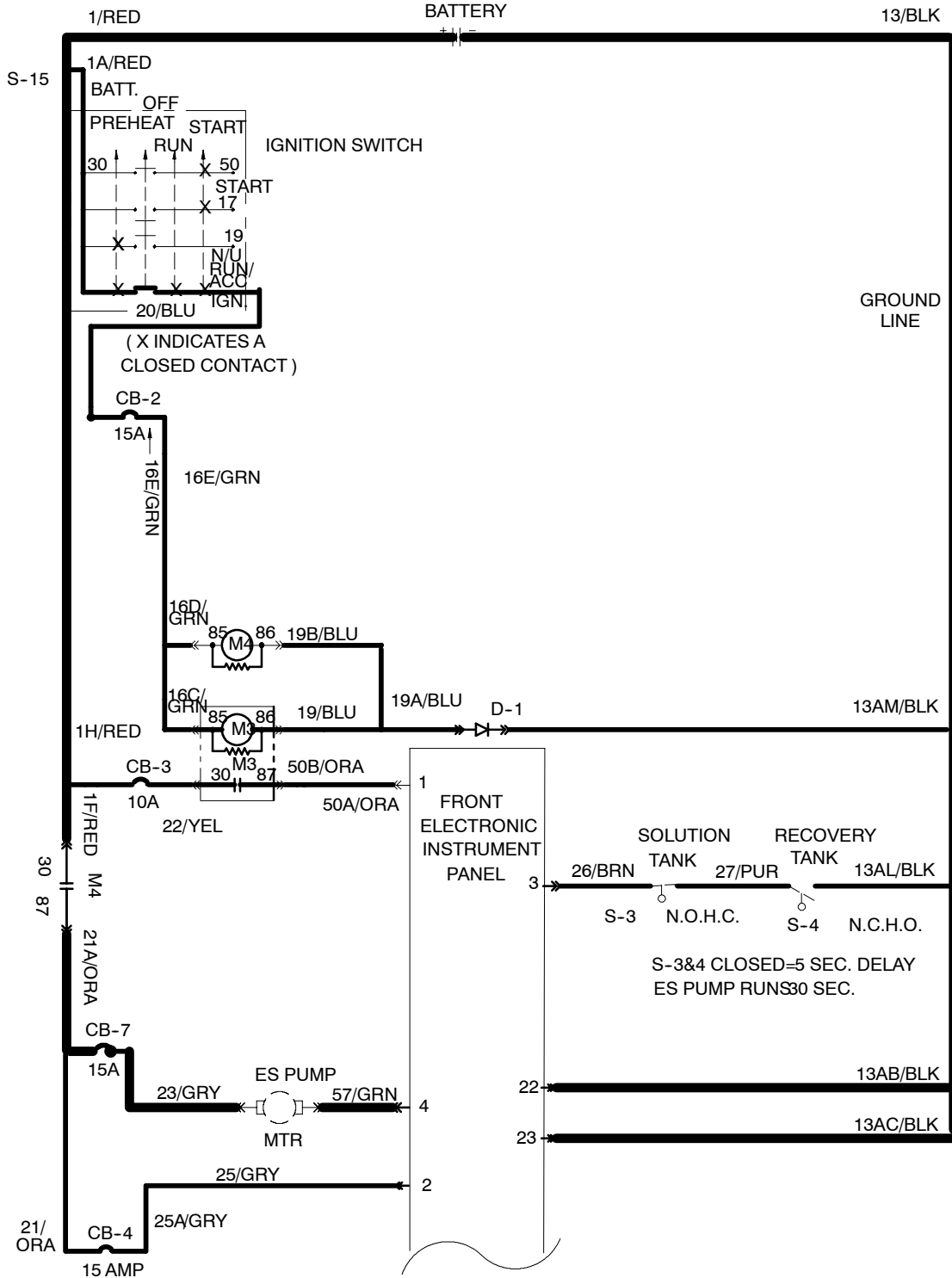

**ES™ PUMP NOT WORKING
(FLOW CHART)**

OPERATION:
 -IF ES IS SELECTED ON PANEL AND
 -S-3 AND S-4 CLOSE FOR 10 SECONDS
 -THE ES PUMP WILL RUN UNTIL S-3 OR
 S-4 OPENS PLUS 40 SECONDS

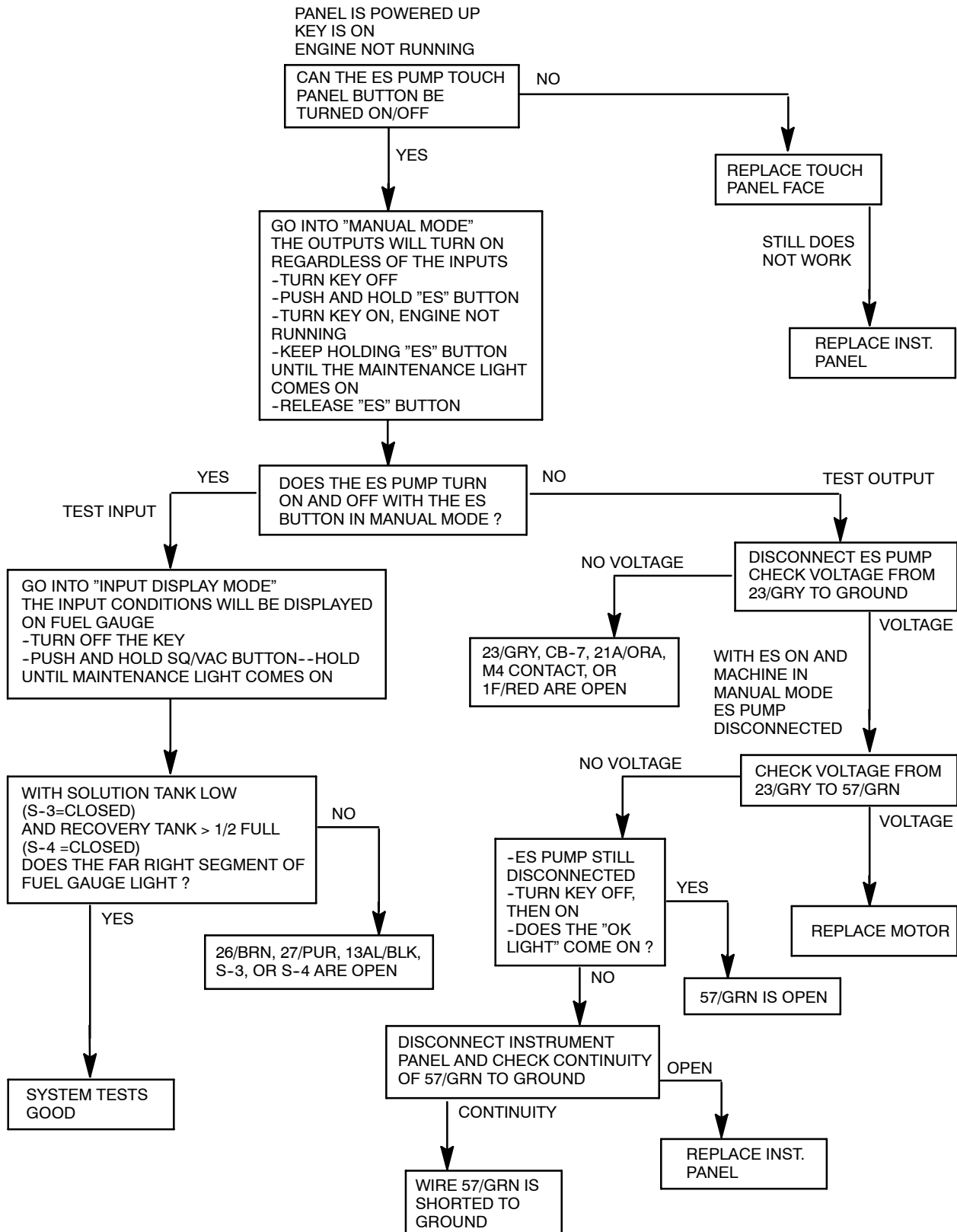

SWEEP BRUSH WILL NOT TURN ON AND LOWER WITH SWEEP 1 SELECTED (SCHEMATIC)

OPERATION:
 -SWEEP 1 SELECTED ON PANEL
 -HOPPER IN DOWN POSITION
 -ENGINE SPEED SET ON HIGH
 -SV-11 AND SV-5 ARE TURNED ON,
 BRUSHES TURN ON AND LOWER
 -HOPPER DOOR OPEN WILL SELECT
 AUTOMATICALLY

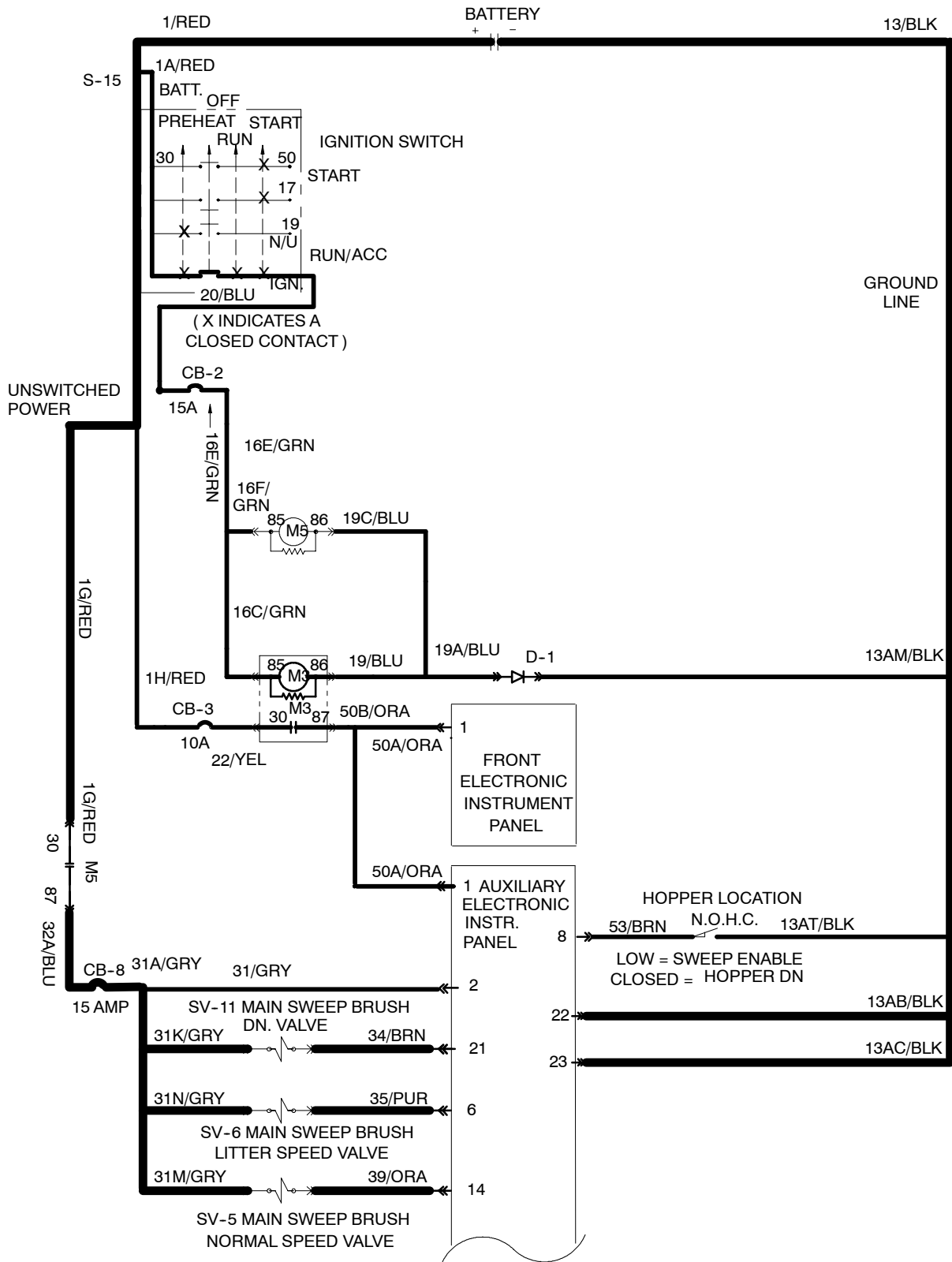

SWEEP BRUSH WILL NOT TURN ON AND LOWER WITH SWEEP 1 SELECTED (FLOW CHART)

OPERATION:
 -SWEEP 1 SELECTED ON PANEL
 -HOPPER IN DOWN POSITION
 -ENGINE SPEED SET ON HIGH
 -SV-11 AND SV-5 ARE TURNED ON,
 BRUSHES TURN ON AND LOWER
 -HOPPER DOOR SELECTED AUTOMATICALLY

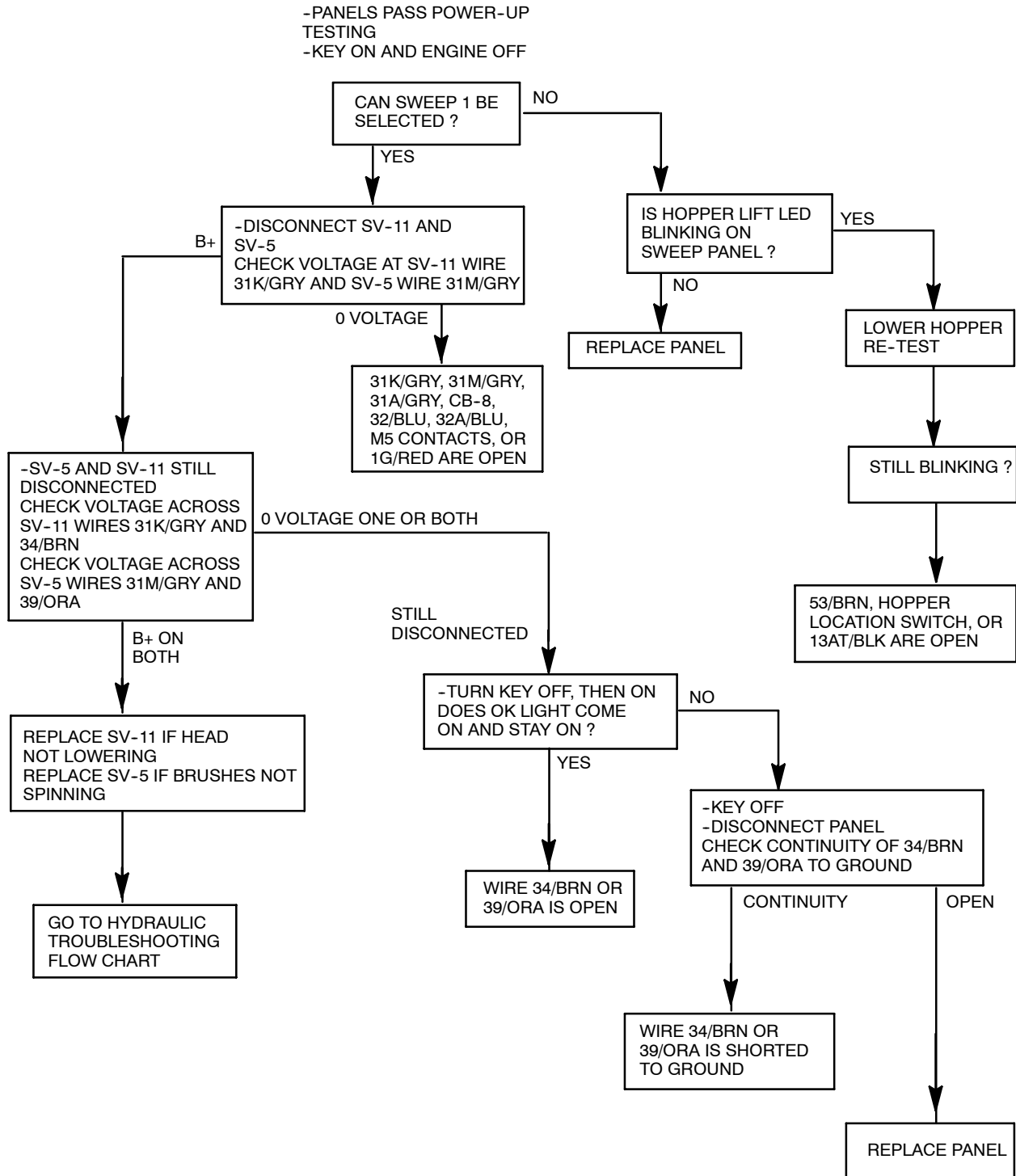

**SWEEP BRUSH WILL NOT
TURN ON AND LOWER
WITH SWEEP 2 SELECTED
SWEEP 1 WORKS
(SCHEMATIC)**

OPERATION:
 -SCRUB FUNCTION OFF
 -SWEEP 2 SELECTED ON PANEL
 -HOPPER IN DOWN POSITION
 -ENGINE SPEED SET ON HIGH
 -SV-11 AND SV-5 ARE TURNED ON, BRUSHES
 TURN ON AND LOWER
 -HOPPER DOOR SELECTED AUTOMATICALLY

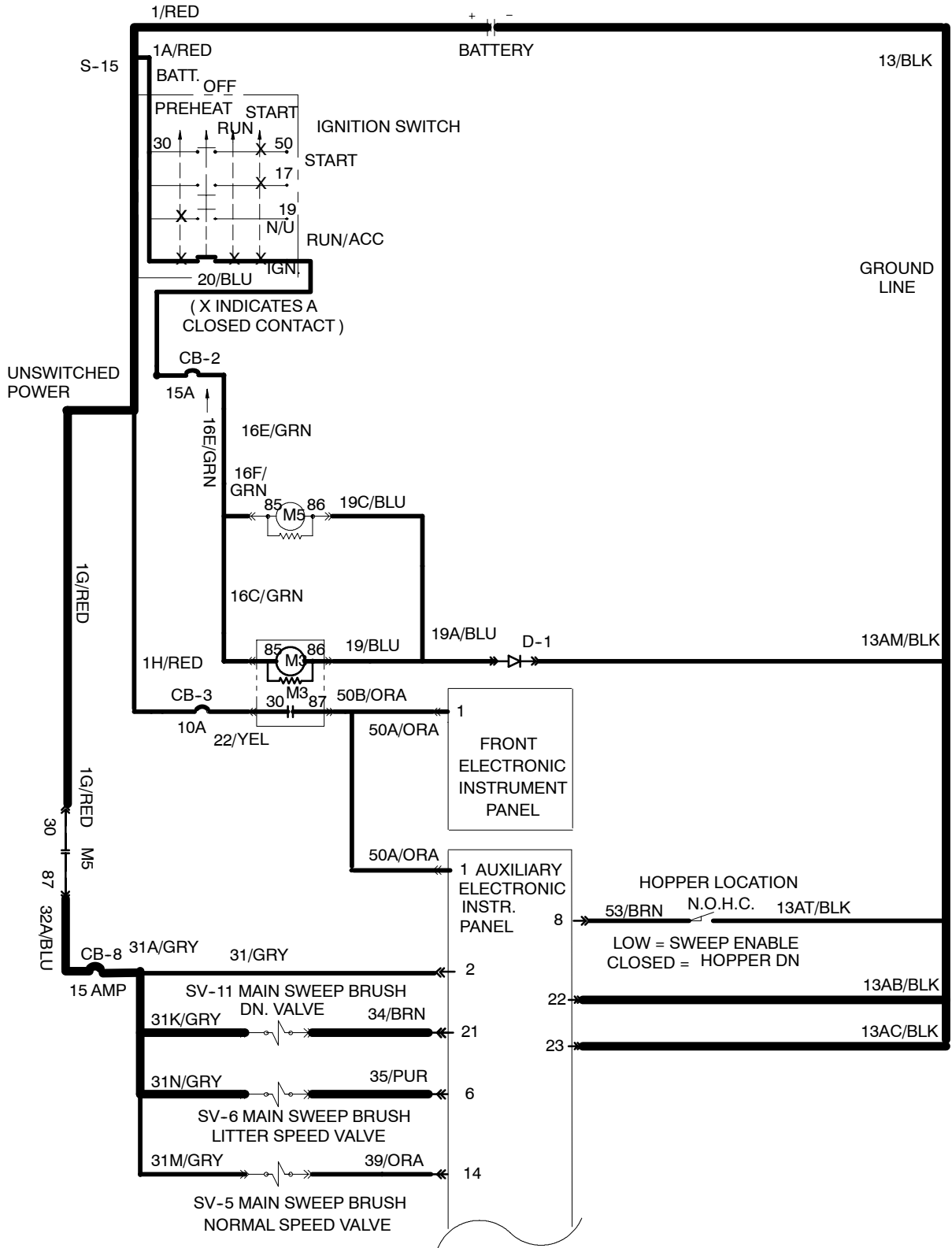

SWEEP BRUSH WILL NOT TURN ON AND LOWER WITH SWEEP 2 SELECTED (FLOW CHART)

OPERATION:
 -SCRUB FUNCTION OFF
 -SWEEP 2 SELECTED ON PANEL
 -HOPPER IN DOWN POSITION
 -ENGINE SPEED SET ON HIGH
 -SV-11 AND SV-5 ARE TURNED ON, BRUSHES TURN ON AND LOWER
 -HOPPER DOOR SELECTED AUTOMATICALLY

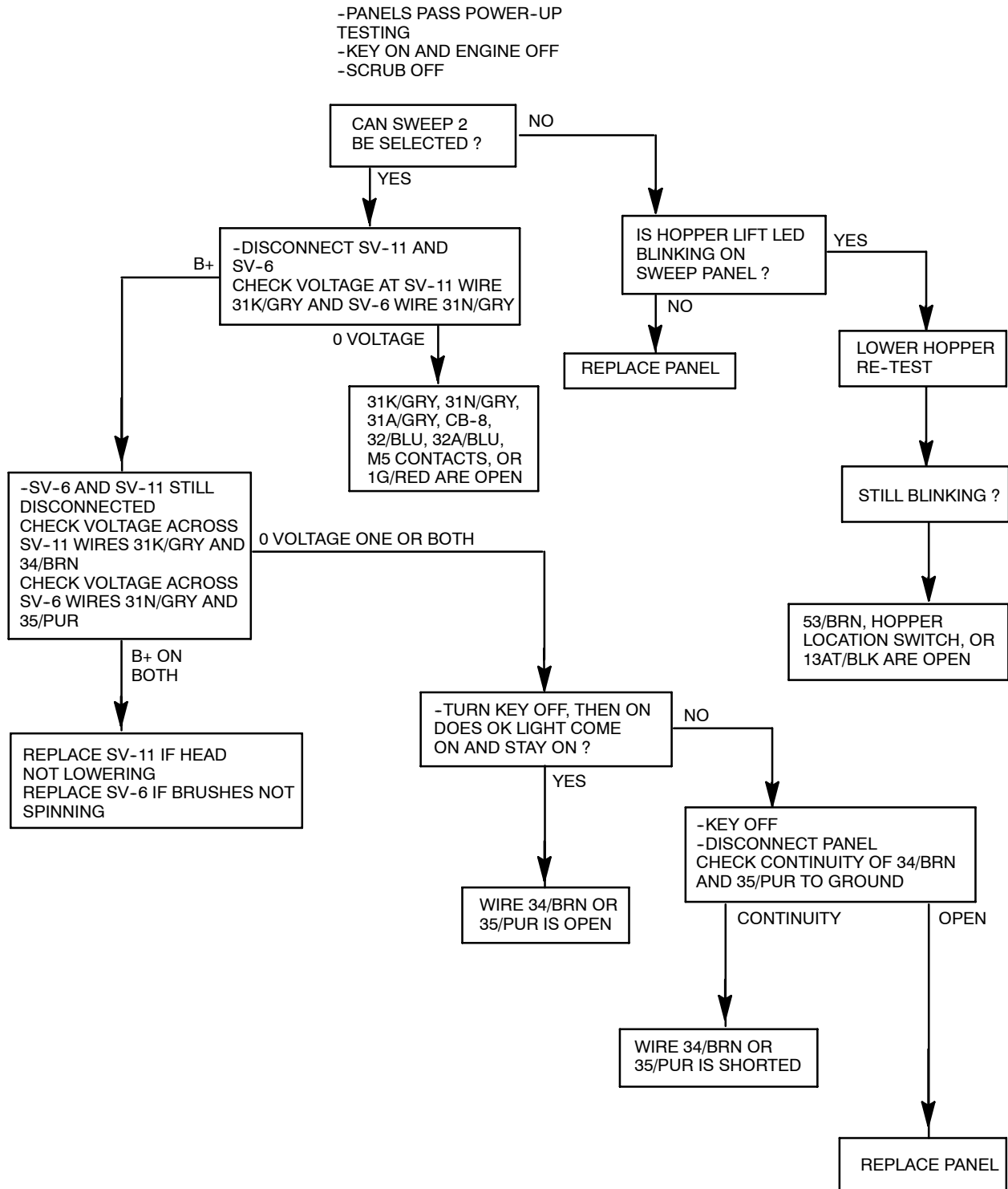

SWEEP SIDE BRUSH WILL NOT TURN ON AND LOWER (SCHEMATIC)

OPERATION:
 -SIDE BRUSH IS SELECTED ON PANEL
 -SWEEP 1 OR 2 ARE ON AND WORKING
 -PIN 11 OF SWEEP PANEL = GROUND
 -SV-13 AND SV-15 TURN ON
 -SIDE BRUSH TURNS ON AND LOWERS

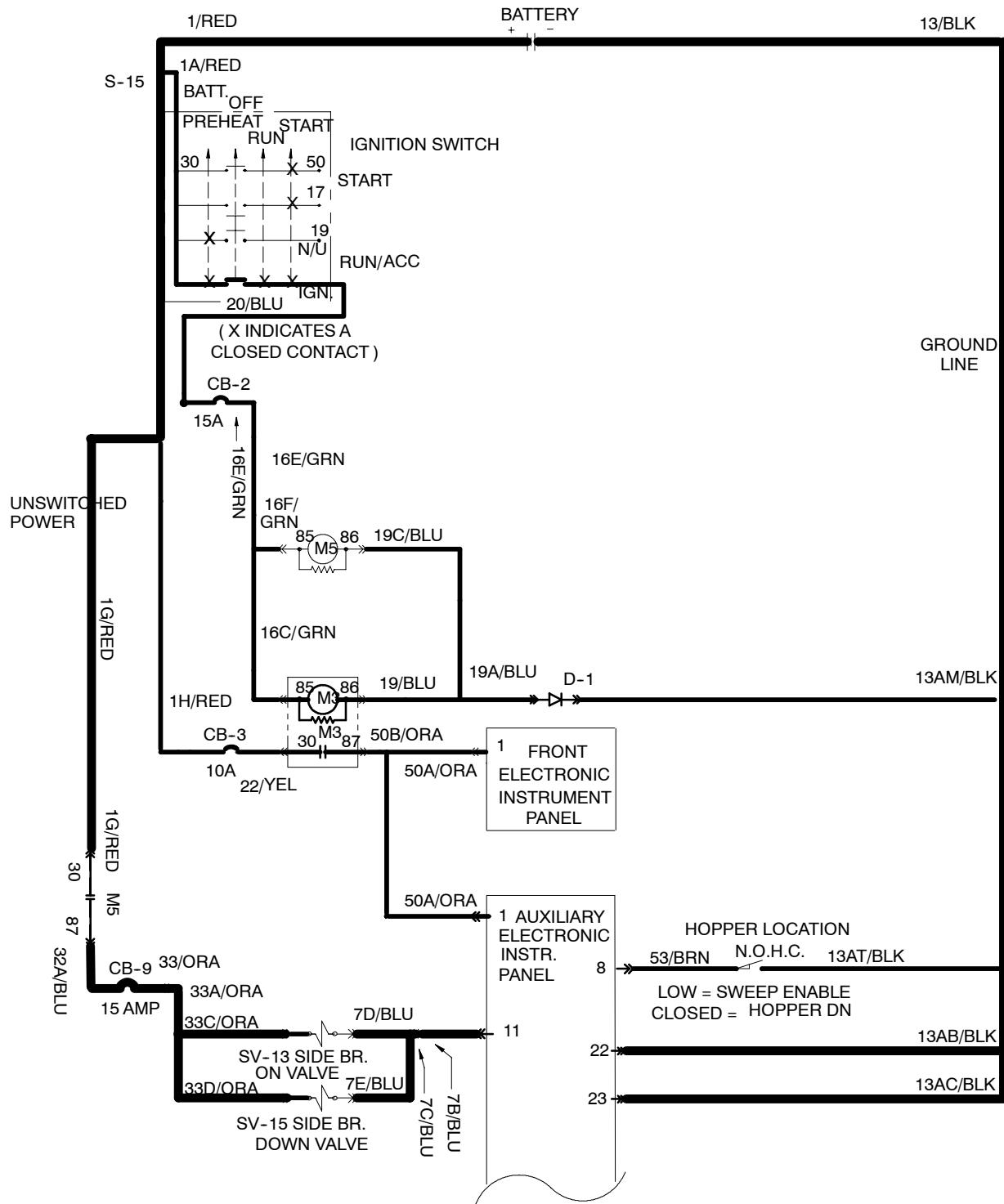

SWEEP SIDE BRUSH WILL NOT TURN ON AND LOWER (FLOW CHART)

OPERATION:

- SIDE BRUSH IS SELECTED ON PANEL
- SWEEP 1 OR 2 ARE ON AND WORKING
- PIN 11 OF SWEEP PANEL = GROUND
- SV-13 AND SV-15 TURN ON
- SIDE BRUSH TURNS ON AND LOWERS

- BOTH PANELS PASS POWER-UP TESTING
- SWEEP SYSTEM IS WORKING
- KEY ON AND ENGINE OFF
- SWEEP 1 OR 2 SELECTED ON

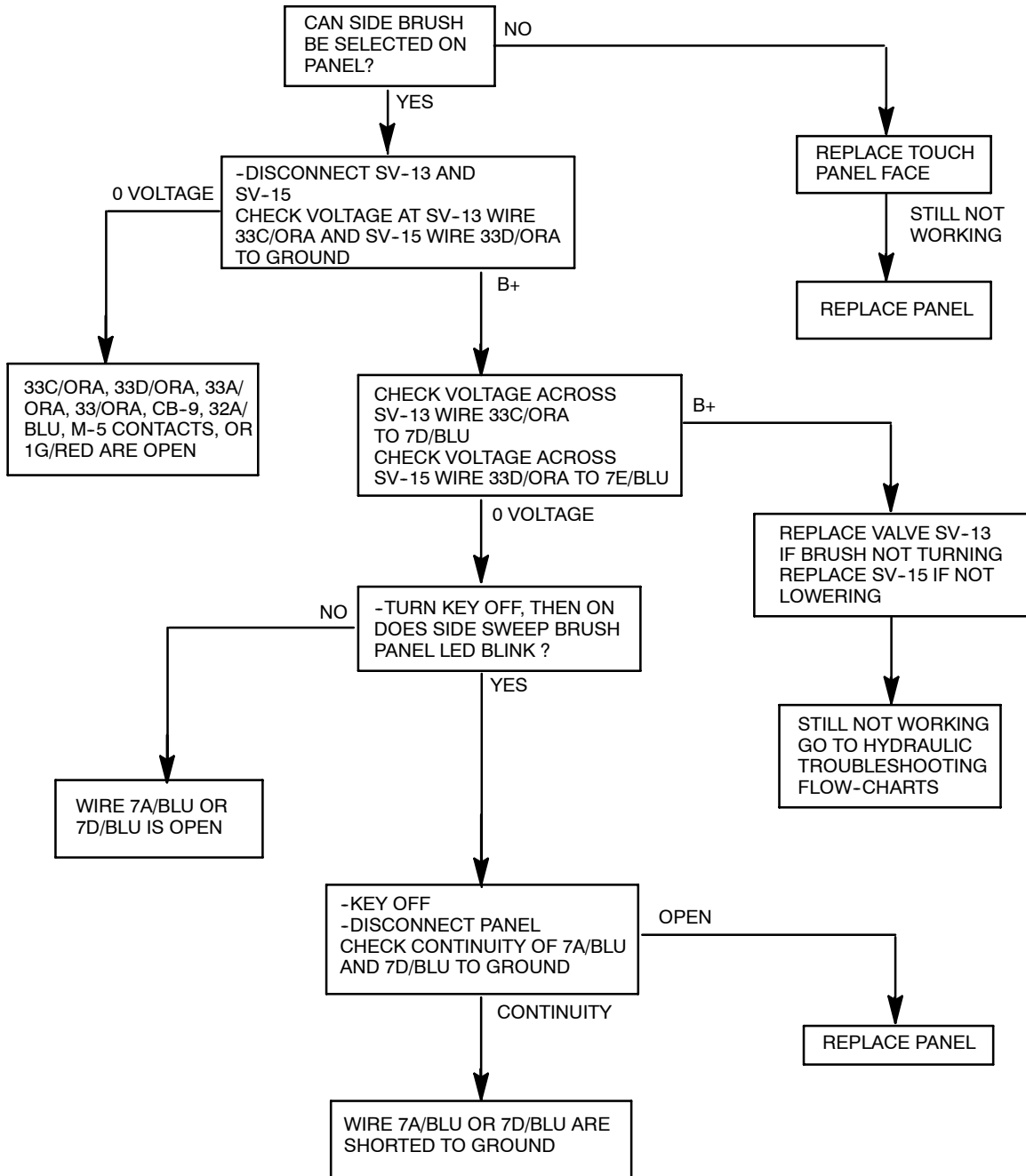

SWEEP VACUUM FAN WILL NOT TURN ON (SCHEMATIC)

OPERATION:
 -SWEEP 1 OR 2 SELECTED
 -SWEEP VACUUM FAN SELECTED (TURNS ON AUTOMATICALLY WHEN SWEEP 1 OR 2 SELECTED AND NO HOPPER THERMAL CONDITION)
 -SV-18 IS TURNED ON

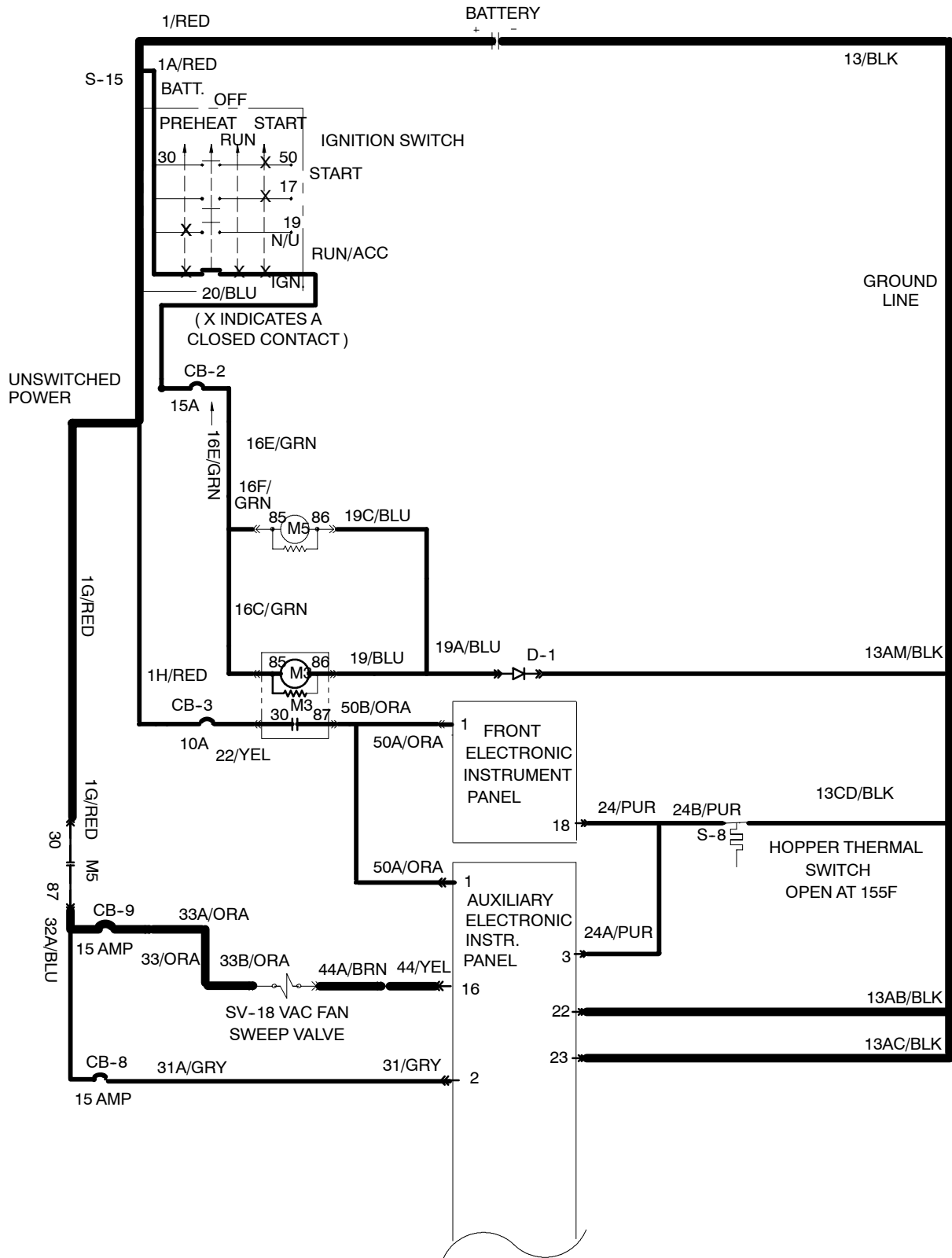

SWEEP VACUUM FAN WILL NOT TURN ON (FLOW CHART)

OPERATION:
 -SWEEP 1 OR 2 SELECTED
 -SWEEP VACUUM FAN SELECTED (TURNS ON AUTOMATICALLY WHEN SWEEP 1 OR 2 SELECTED AND NO HOPPER THERMAL CONDITION)
 -SV-18 IS TURNED ON

-SWEEP 1 WORKS (BRUSHES SPIN AND HEAD LOWERS)
 -KEY ON AND ENGINE OFF

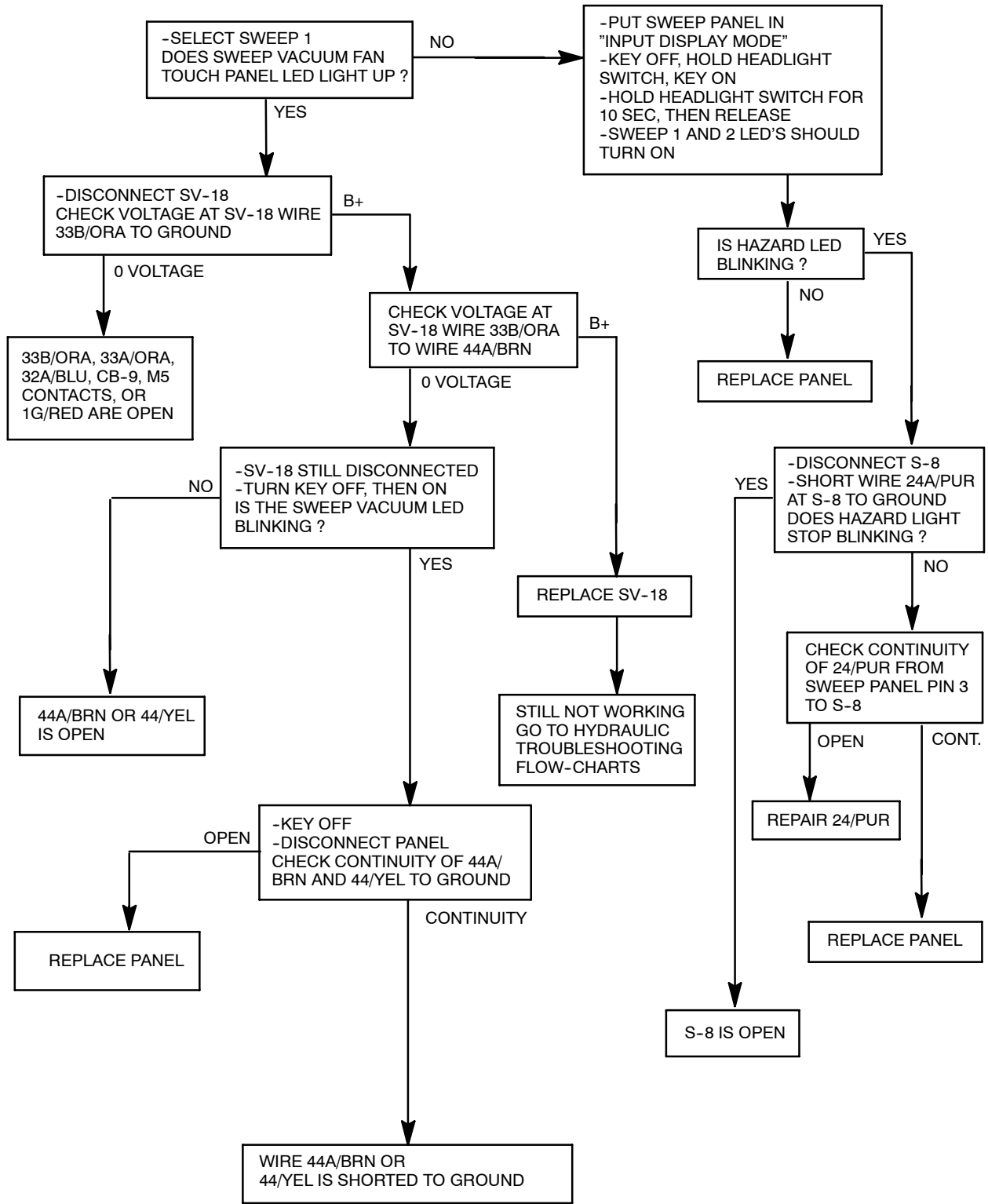

SHAKER SYSTEM WILL NOT TURN ON (SCHEMATIC)

OPERATION:
-SWEEP AND SWEEP FAN MUST BE OFF
-SHAKE SYSTEM SELECTED ON PANEL
-ONCE ACTIVATED M6 IS TURNED ON FOR 40 SECONDS
-RUNS FOR 15 SECONDS EVERY TIME SWEEP SYSTEM IS TURNED OFF

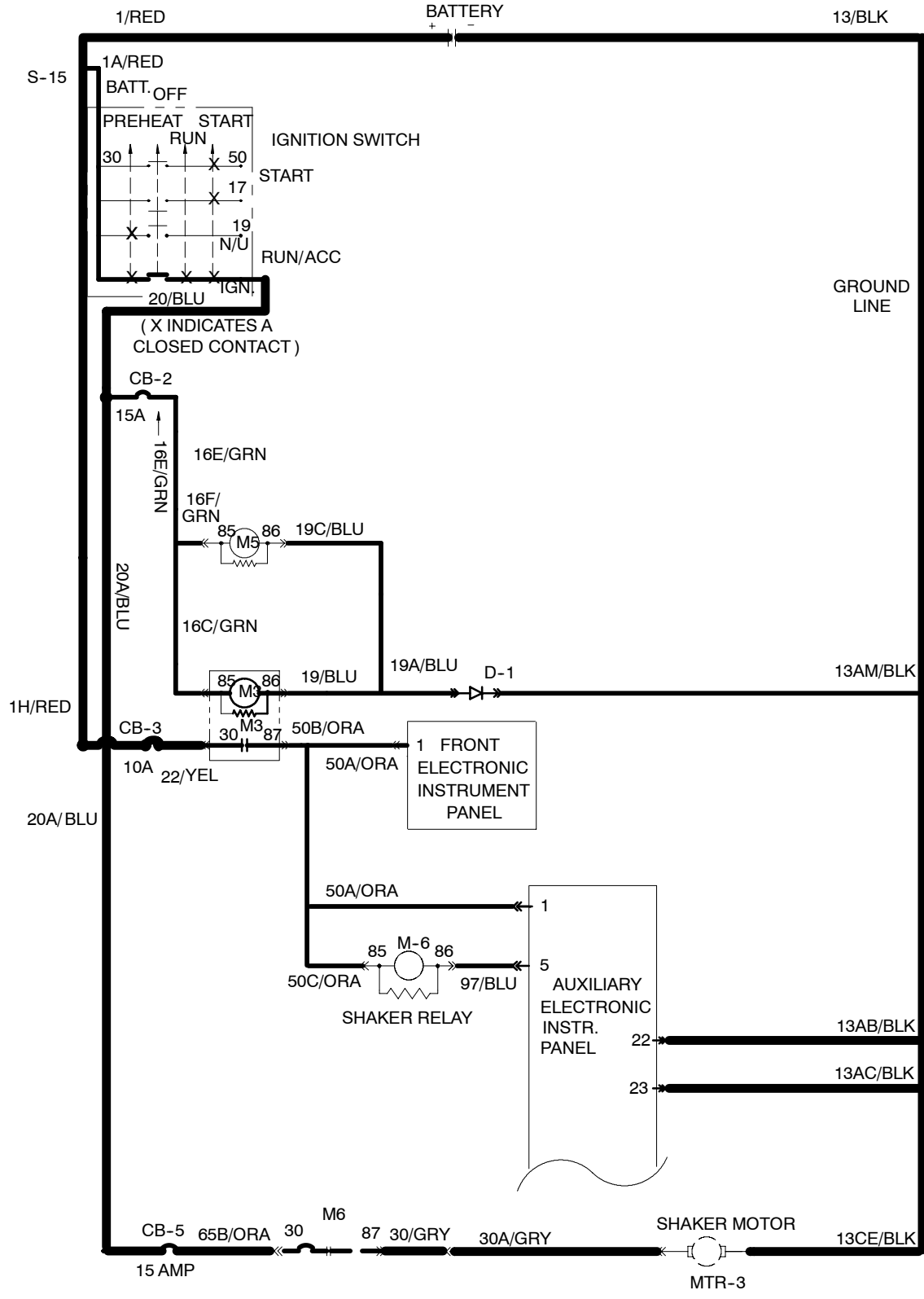

SHAKER SYSTEM WILL NOT TURN ON (FLOW CHART)

OPERATION:
 -SWEEP AND SWEEP FAN MUST BE OFF
 -SHAKE SYSTEM SELECTED ON PANEL
 -ONCE ACTIVATED M6 IS TURNED ON FOR 40 SECONDS
 -RUNS FOR 15 SECONDS EVERY TIME SWEEP SYSTEM IS TURNED OFF

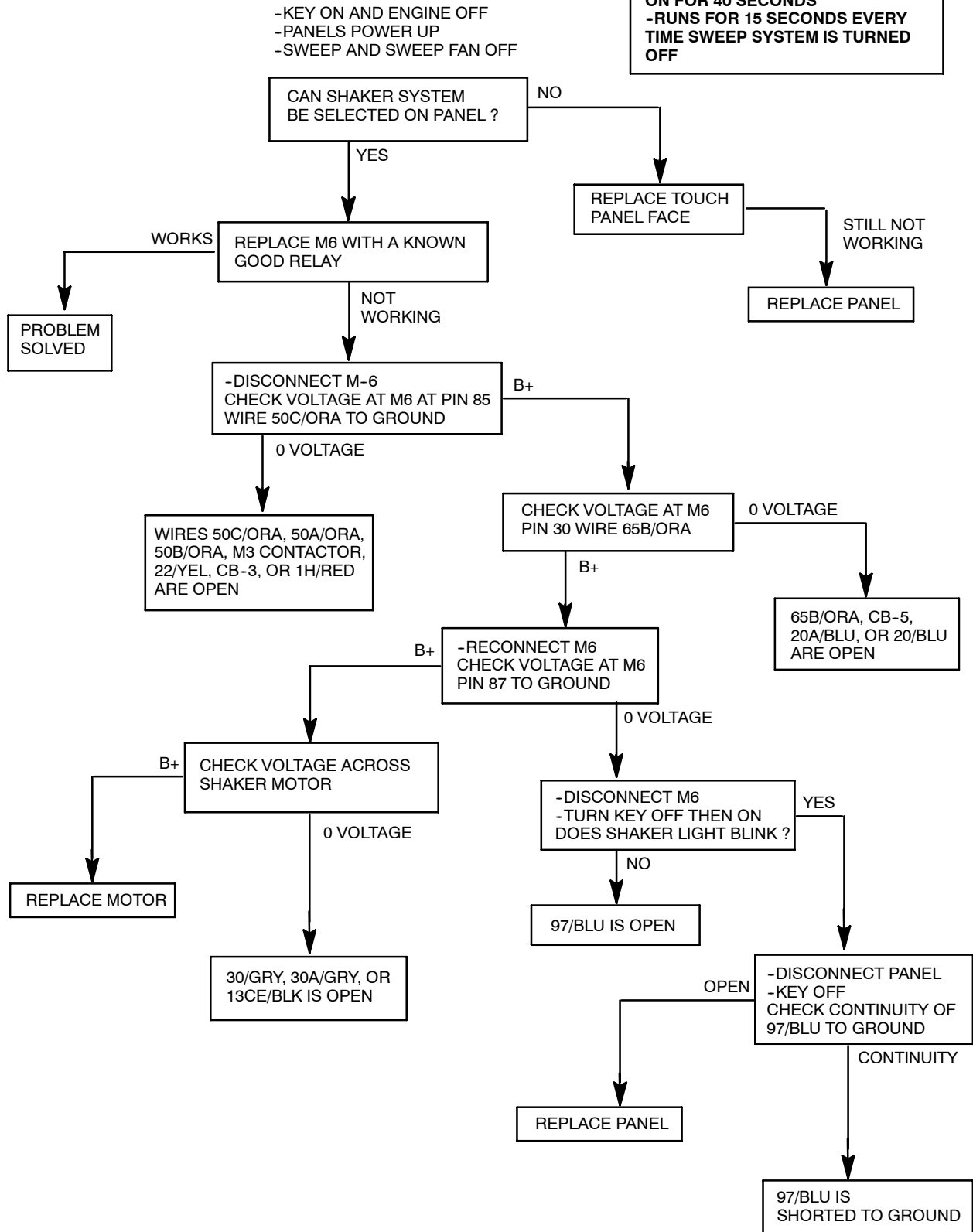

HOPPER DIFFERENTIAL PRESSURE LIGHT ALWAYS ON (SCHEMATIC)

OPERATION;
 -IF THE DIFFERENCE IN AIR PRESSURE ON BOTH SIDES OF THE SWEEP FILTER EXCEED 20 INCHES OF H₂O THE PRESSURE SWITCH CLOSSES
 -THE PRESSURE SWITCH CLOSING WILL SUPPLY A GROUND AT PIN 6 TURNING ON THE LIGHT
 -THIS LIGHT TELLS THE OPERATOR TO RUN THE SHAKER SYSTEM

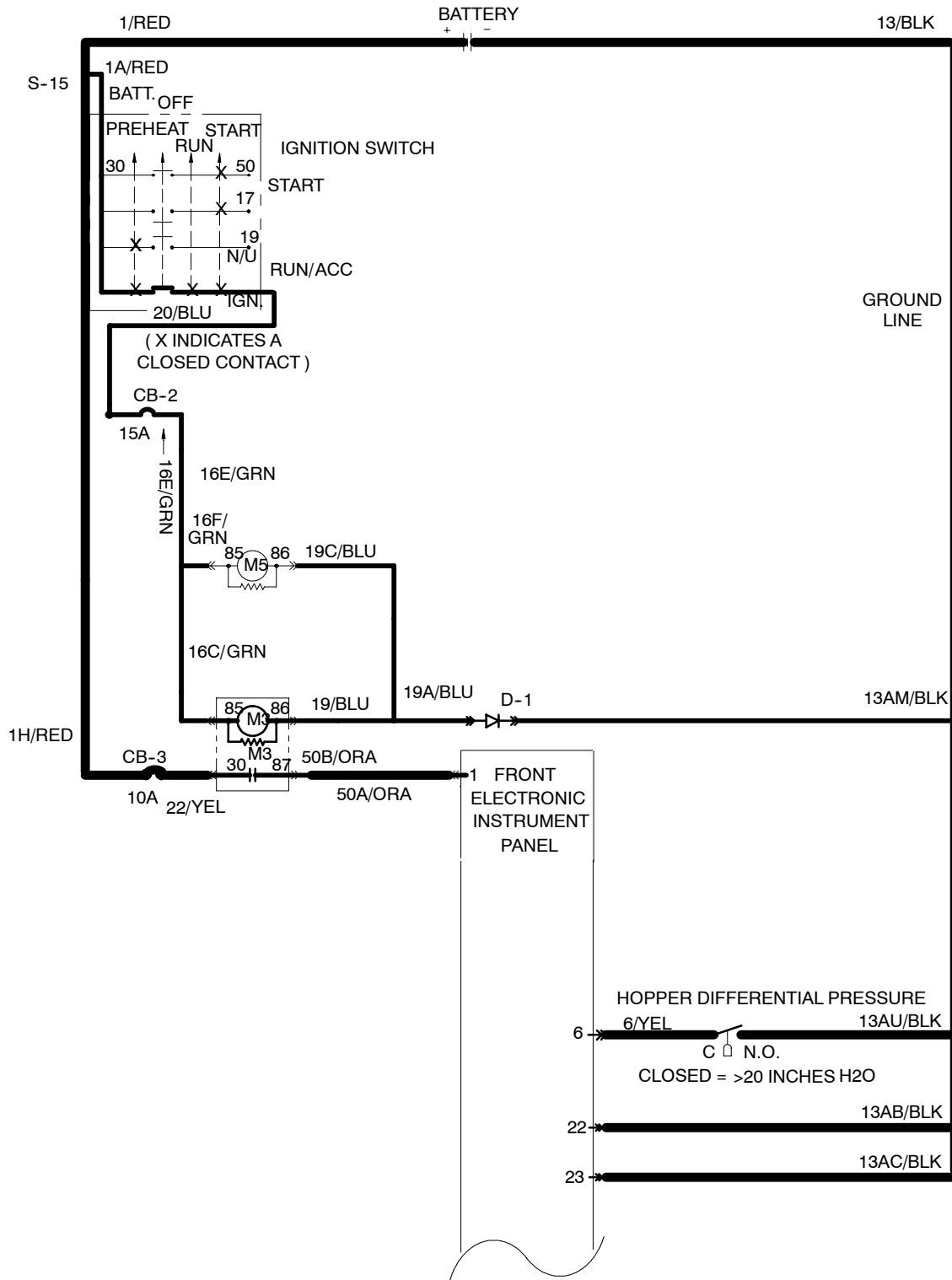

HOPPER DIFFERENTIAL PRESSURE SWITCH ALWAYS ON (FLOW CHART)

OPERATION;
 -IF THE DIFFERENCE IN AIR PRESSURE ON BOTH SIDES OF THE SWEEP FILTER EXCEED 20 INCHES OF H2O THE PRESSURE SWITCH CLOSES
 -THE PRESSURE SWITCH CLOSING WILL SUPPLY A GROUND AT PIN 6 TURNING ON THE LIGHT
 -THIS LIGHT TELLS THE OPERATOR TO RUN THE SHAKER SYSTEM

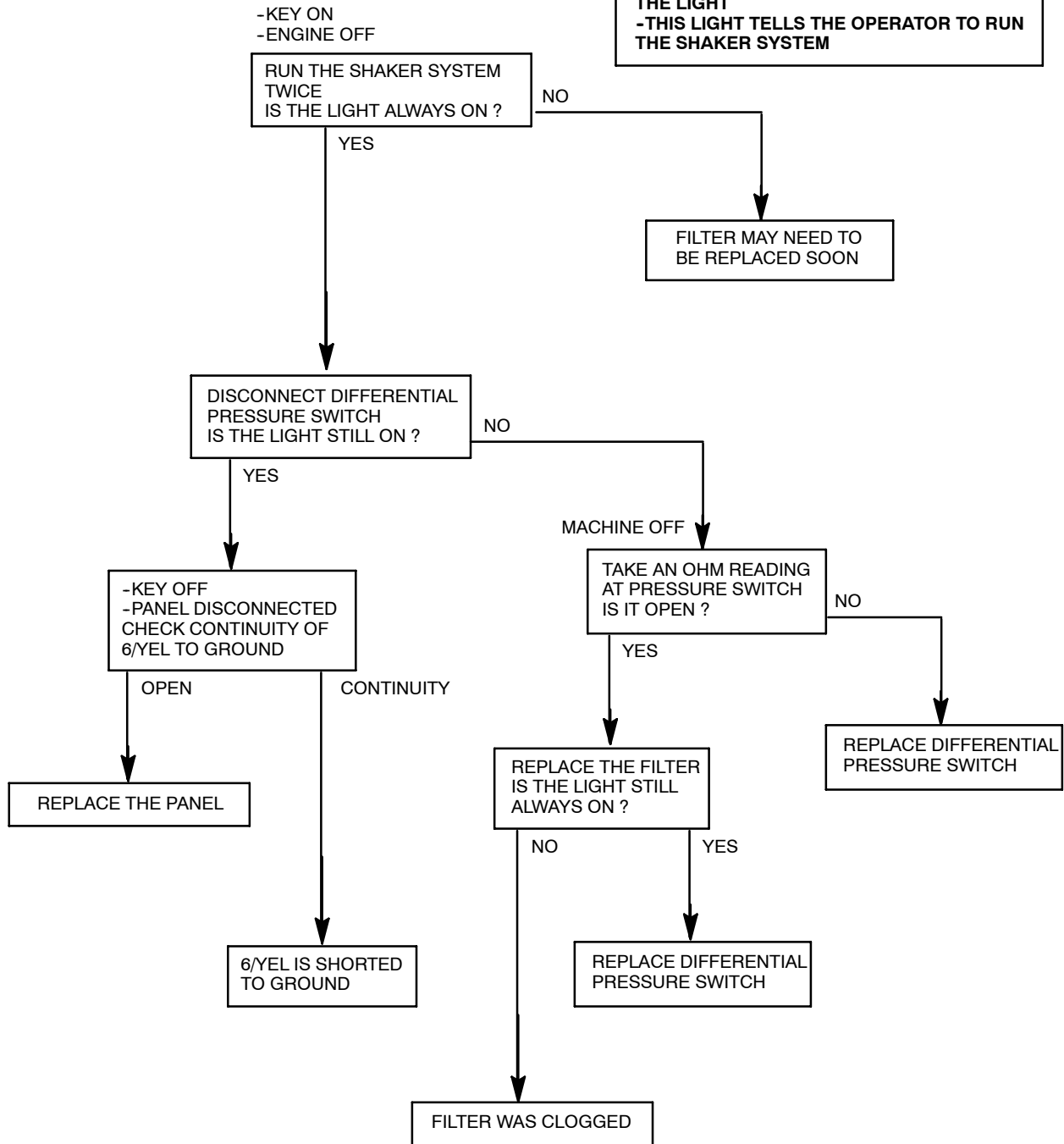

HOPPER DIFFERENTIAL PRESSURE SWITCH ALWAYS OFF (SCHEMATIC)

OPERATION;
 -IF THE DIFFERENCE IN AIR PRESSURE ON BOTH SIDES OF THE SWEEP FILTER EXCEED 20 INCHES OF H₂O THE PRESSURE SWITCH CLOSES
 -THE PRESSURE SWITCH CLOSING WILL SUPPLY A GROUND AT PIN 6 TURNING ON THE LIGHT
 -THIS LIGHT TELLS THE OPERATOR TO RUN THE SHAKER SYSTEM

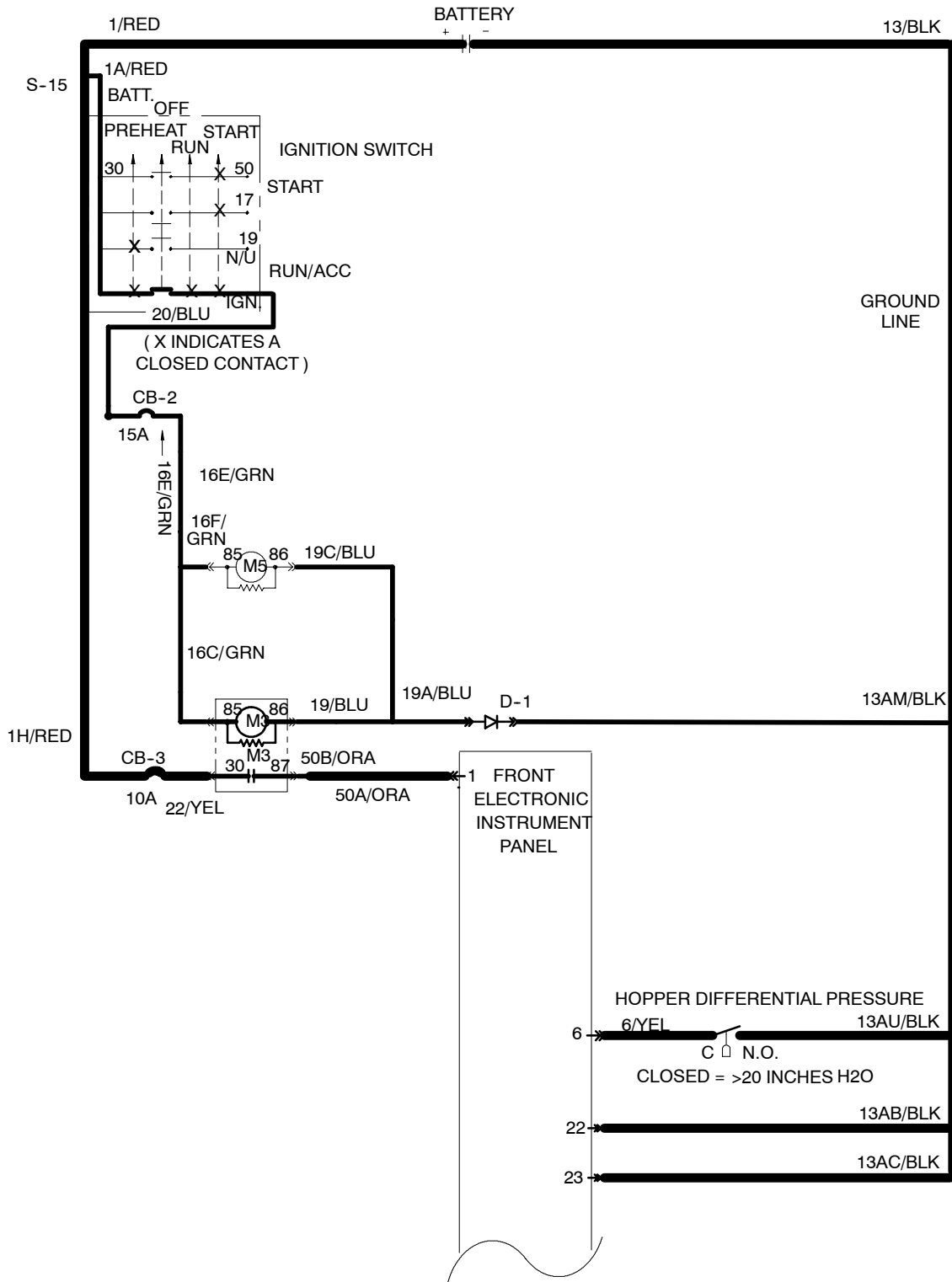

HOPPER DIFFERENTIAL PRESSURE LIGHT ALWAYS OFF (FLOW CHART)

OPERATION;
-IF THE DIFFERENCE IN AIR PRESSURE ON BOTH SIDES OF THE SWEEP FILTER EXCEED 20 INCHES OF H₂O THE PRESSURE SWITCH CLOSSES
-THE PRESSURE SWITCH CLOSING WILL SUPPLY A GROUND AT PIN 6 TURNING ON THE LIGHT
-THIS LIGHT TELLS THE OPERATOR TO RUN THE SHAKER SYSTEM

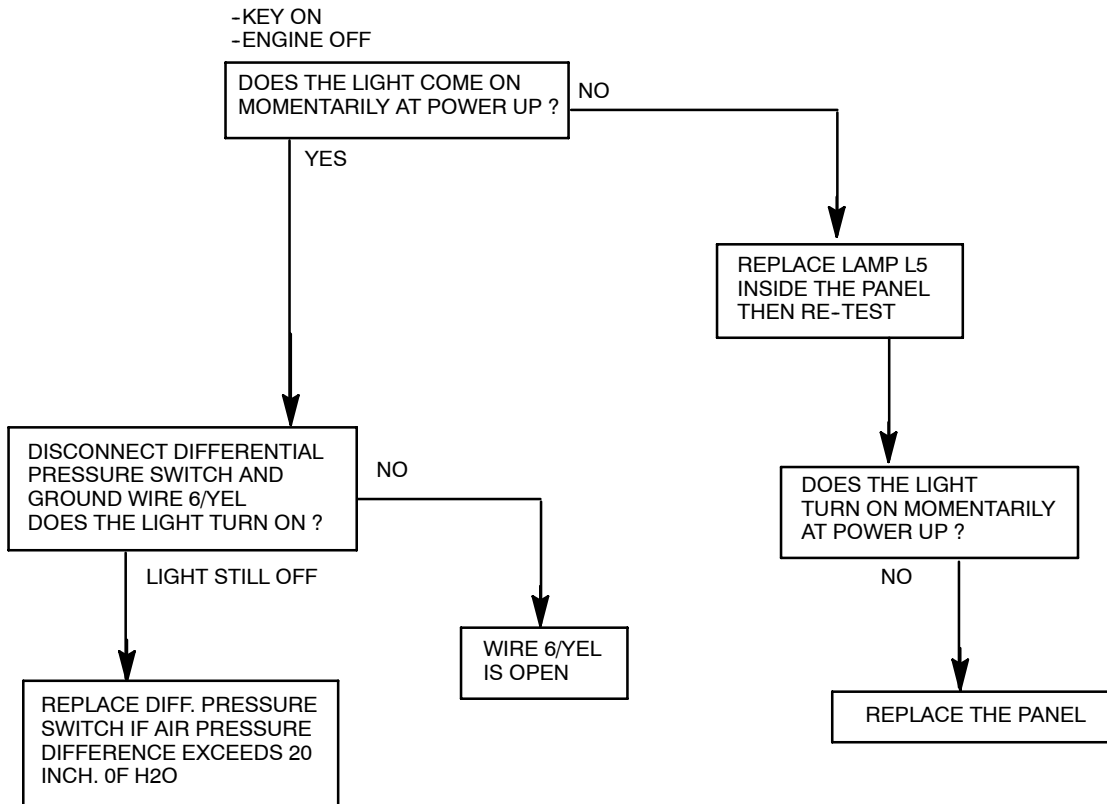

**HOPPER THERMAL SENTRY
LIGHT ALWAYS ON
(SCHEMATIC)**

OPERATION:
 -HOPPER TEMPERATURE EXCEEDS 155° F
 -S-8 OPENS
 -HOPPER THERMAL SENTRY LIGHT TURNS ON

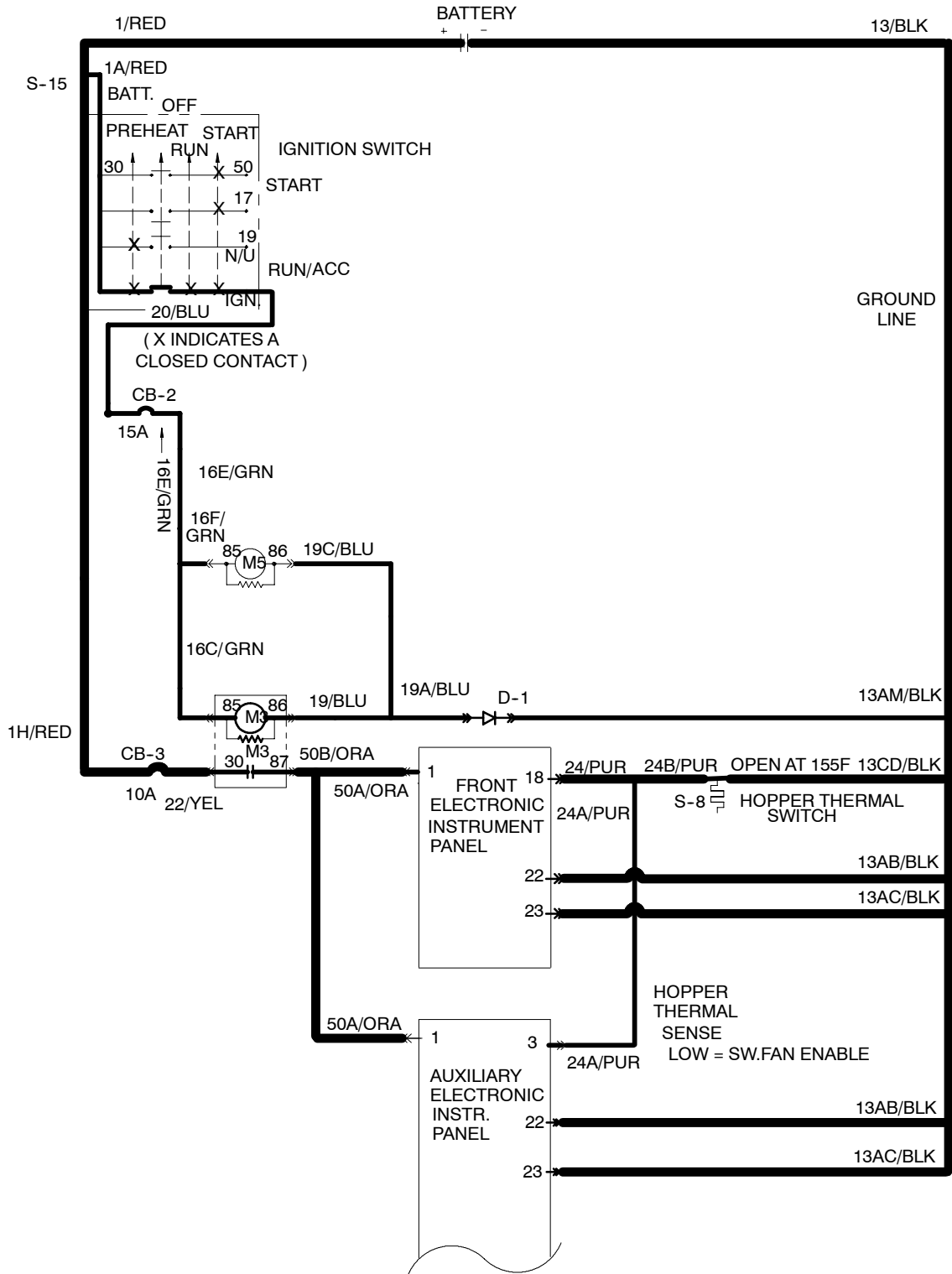

**HOPPER THERMAL SENTRY
LIGHT ALWAYS ON
(FLOW CHART)**

OPERATION:
-HOPPER TEMPERATURE EXCEEDS 155° F
-S-8 OPENS
-HOPPER THERMAL SENTRY LIGHT TURNS ON

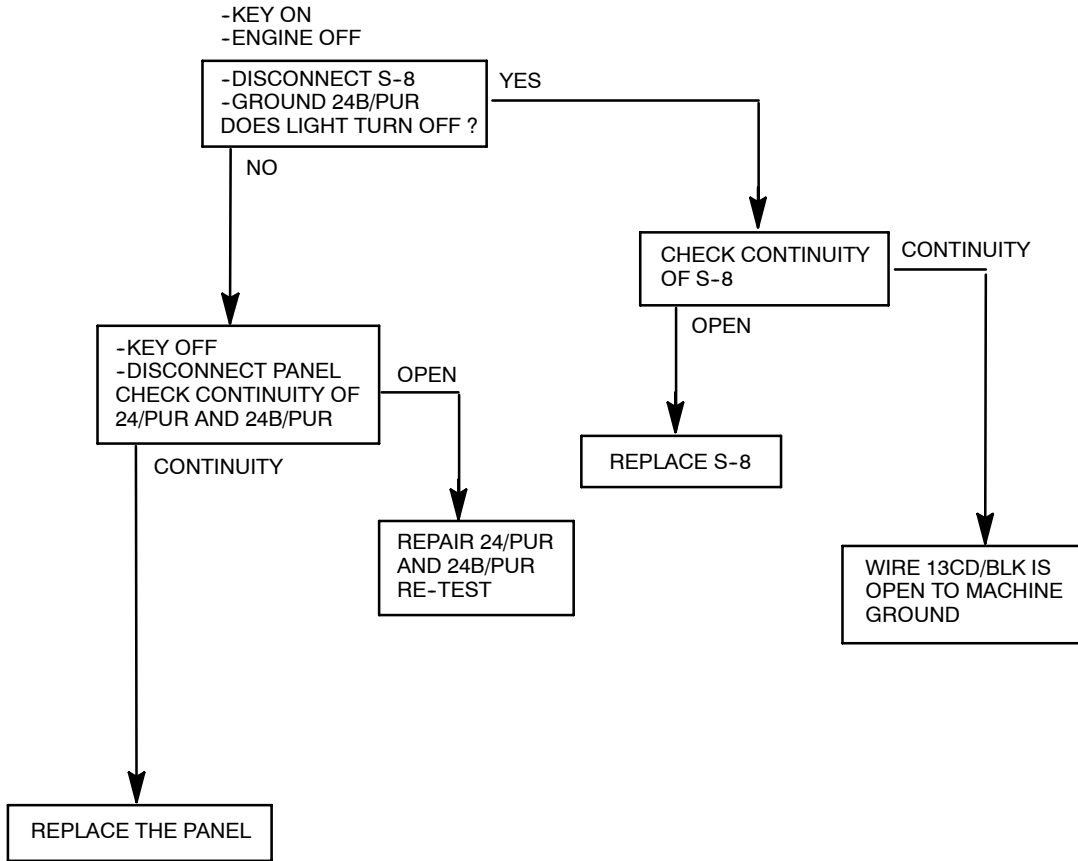

**HOPPER THERMAL SENTRY
LIGHT ALWAYS OFF
(SCHEMATIC)**

OPERATION:
 -HOPPER TEMPERATURE EXCEEDS 155° F
 -S-8 OPENS
 -HOPPER THERMAL SENTRY LIGHT TURNS ON

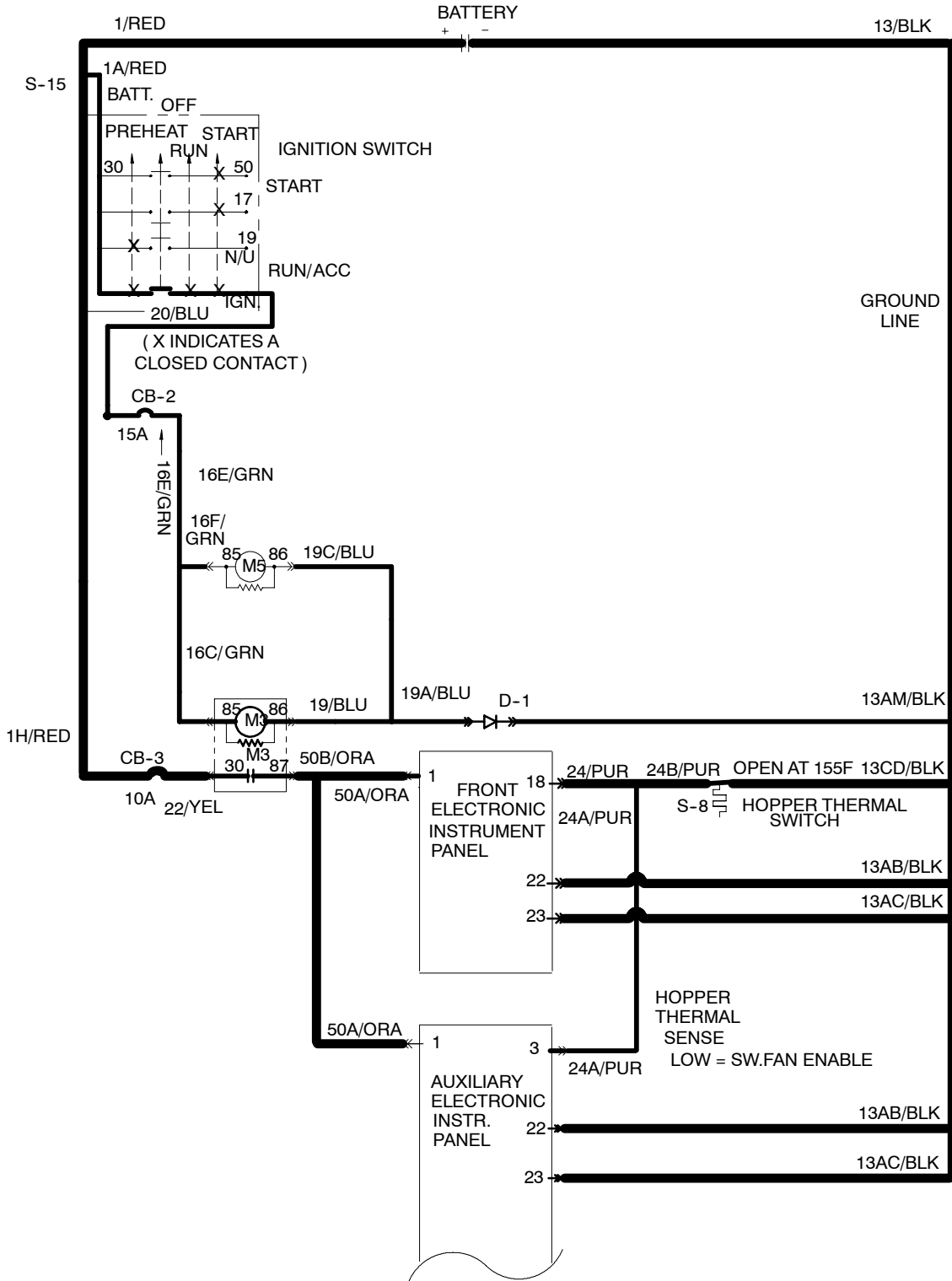

**HOPPER THERMAL SENTRY
LIGHT ALWAYS OFF
(FLOW CHART)**

OPERATION:
-HOPPER TEMPERATURE EXCEEDS 155° F
-S-8 OPENS
-HOPPER THERMAL SENTRY LIGHT TURNS ON

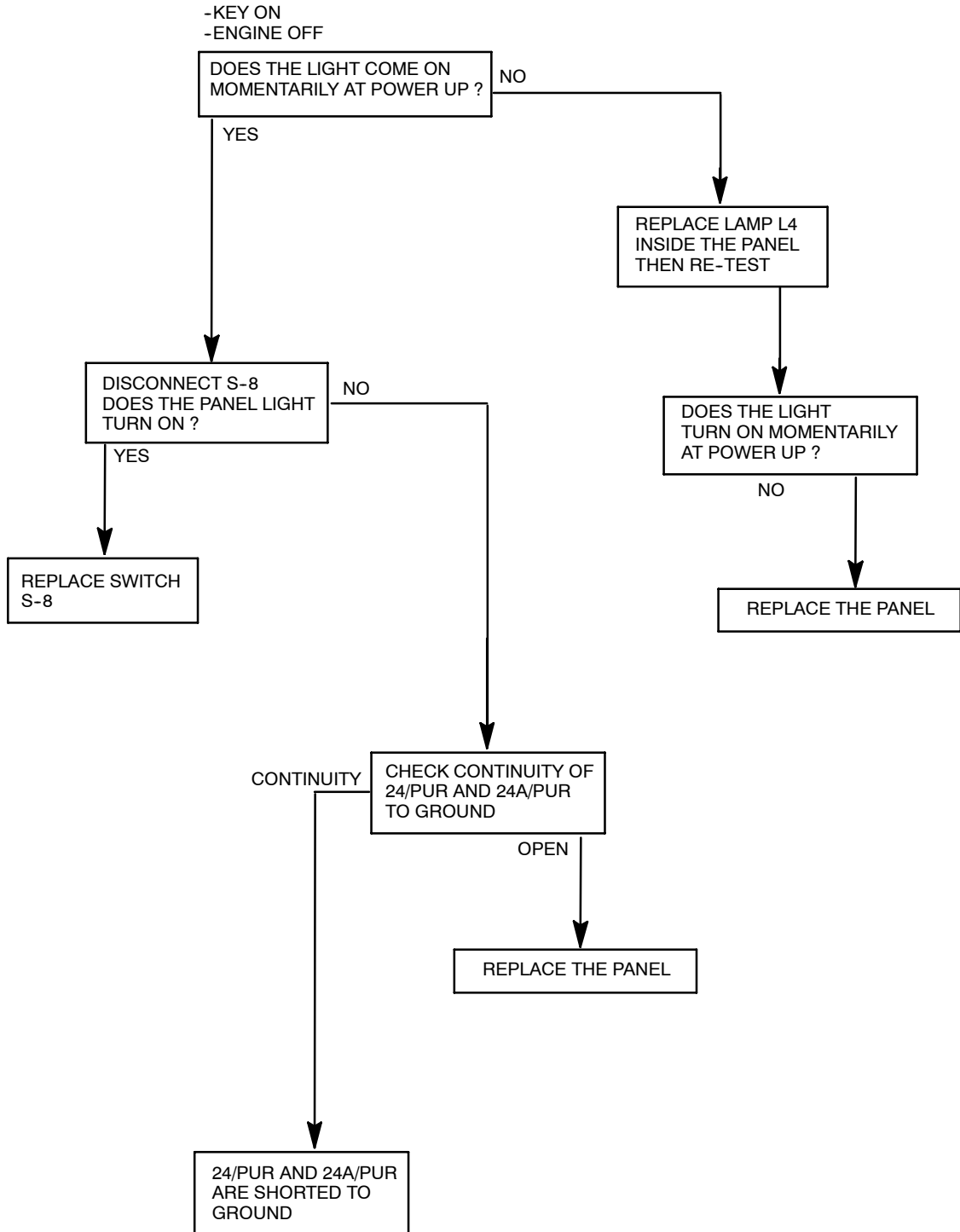

**HOPPER WILL NOT LIFT
(SCHEMATIC)**

OPERATION:
 -HOLDING MOMENTARY HOPPER
 LIFT SWITCH ON TOUCH PANEL
 WILL:
 -TURN ON SV-8
**NOTE: IF SWEEP IS SELECTED
 WHEN HOPPER IS UP, THE LIFT
 LIGHT WILL BLINK AND SWEEP WILL
 BE TURNED OFF AUTOMATICALLY**

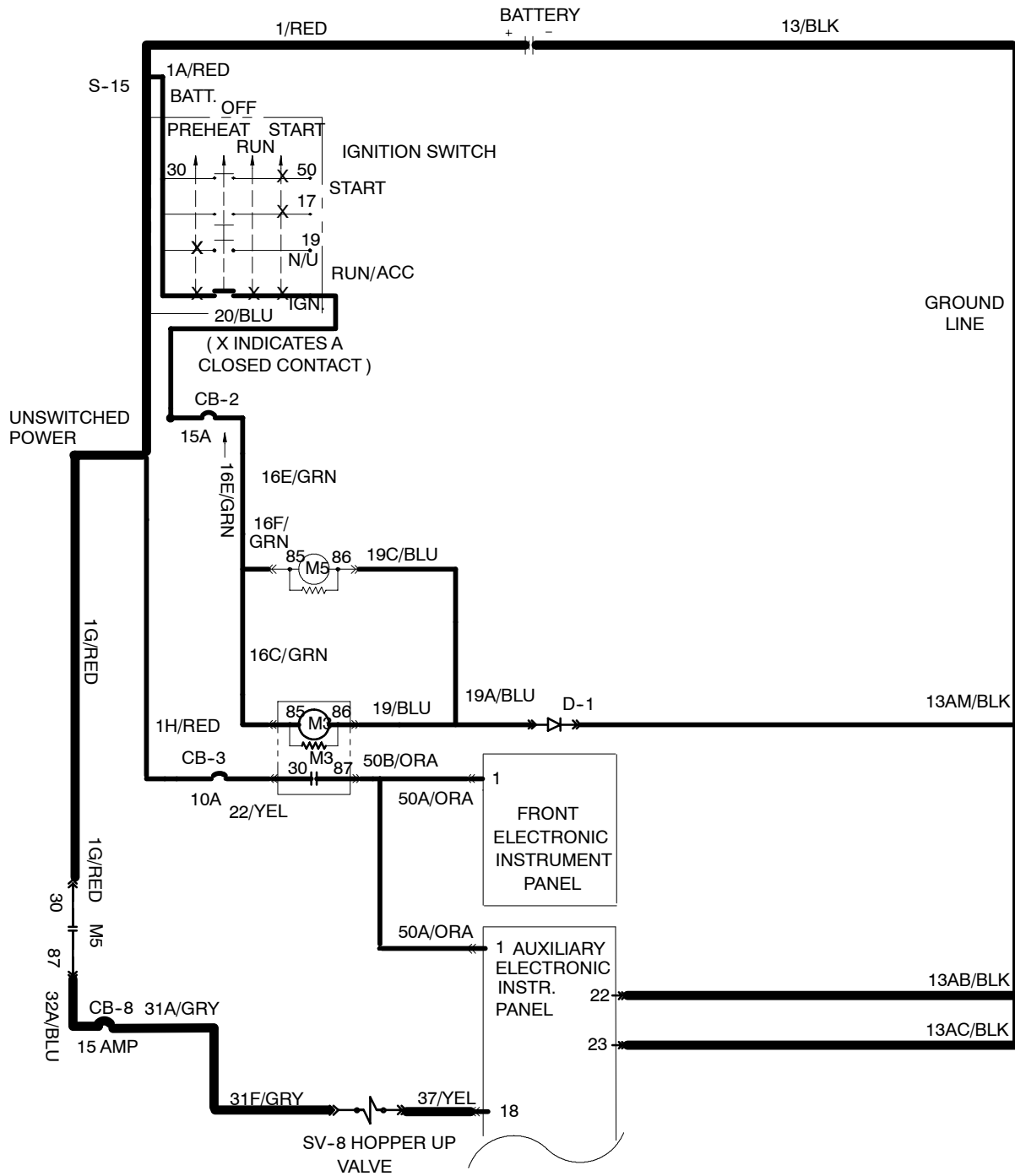

**HOPPER WILL NOT LIFT
(FLOW CHART)**

OPERATION:
 -HOLDING MOMENTARY HOPPER
 LIFT SWITCH ON TOUCH PANEL
 WILL:
 -TURN ON SV-8
**NOTE: IF SWEEP IS SELECTED
 WHEN HOPPER IS UP, THE LIFT
 LIGHT WILL BLINK AND SWEEP WILL
 BE TURNED OFF AUTOMATICALLY**

-KEY ON AND ENGINE OFF
 -PANELS POWER UP

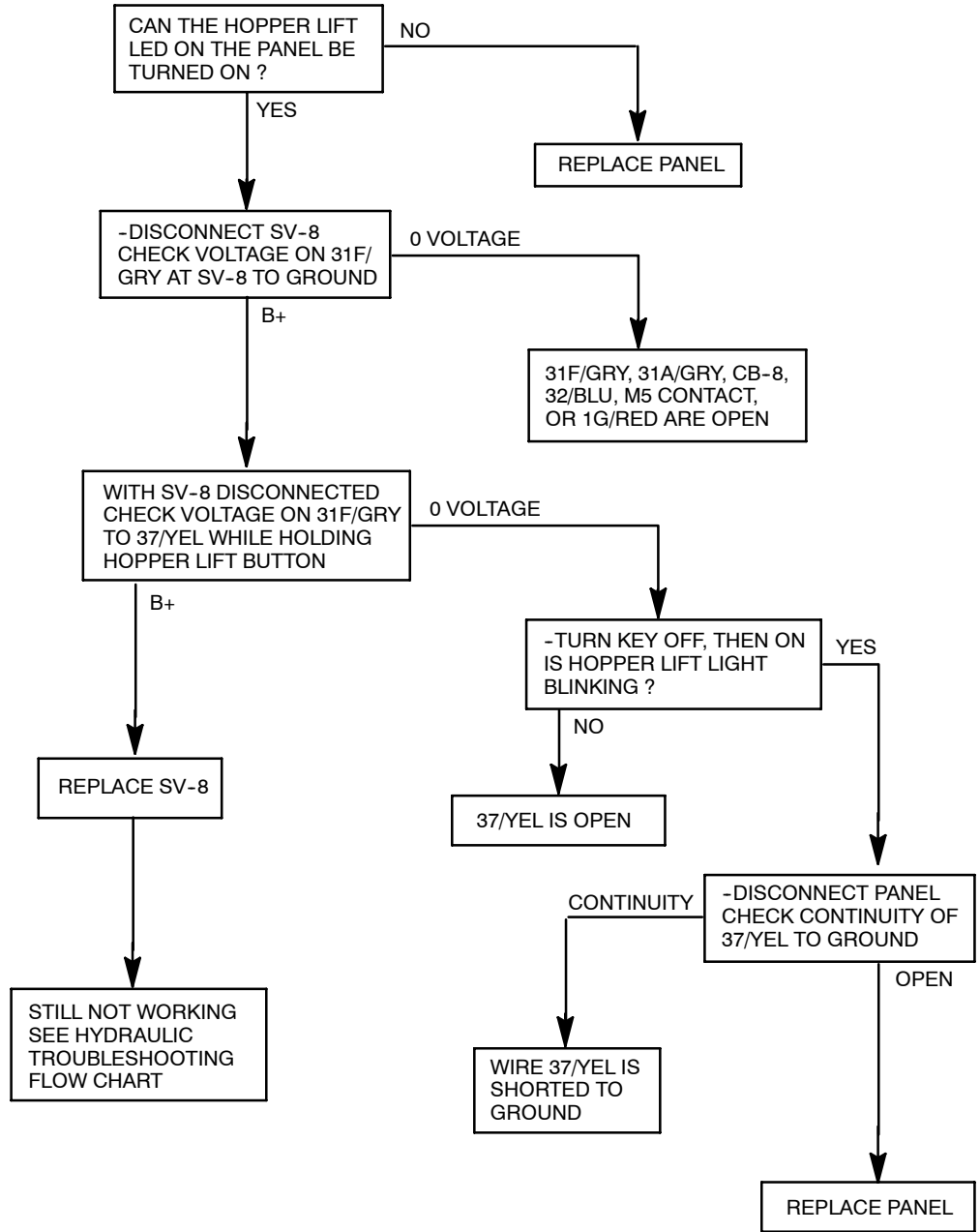

HOPPER WILL NOT LOWER
(SCHEMATIC)

OPERATION:
-HOLDING MOMENTARY HOPPER
LOWER SWITCH ON TOUCH PANEL
WILL:
-TURN ON SV-9

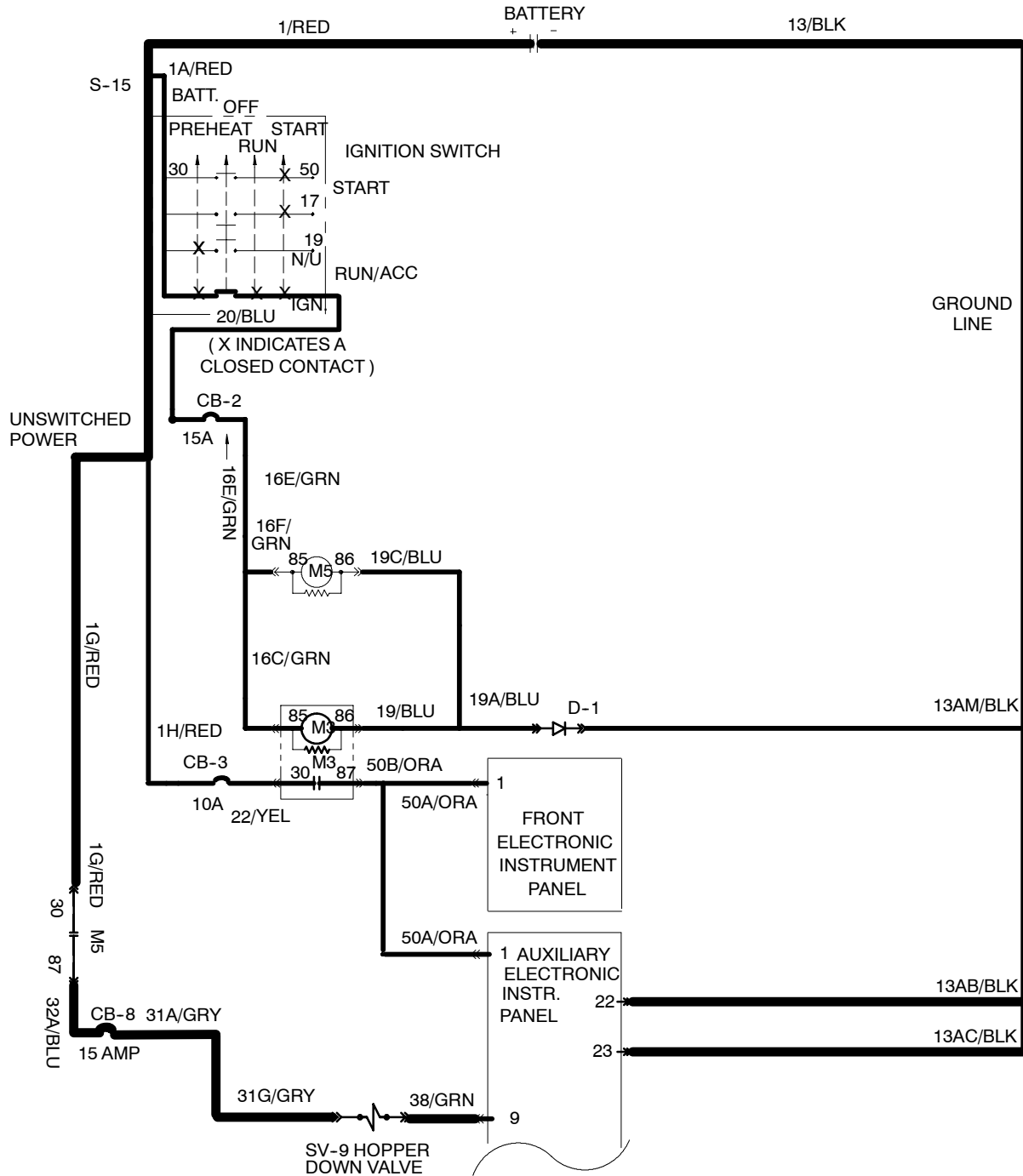

**HOPPER WILL NOT LOWER
(FLOW CHART)**

OPERATION:
 -HOLDING MOMENTARY HOPPER LOWER SWITCH ON TOUCH PANEL
 WILL:
 -TURN ON SV-9

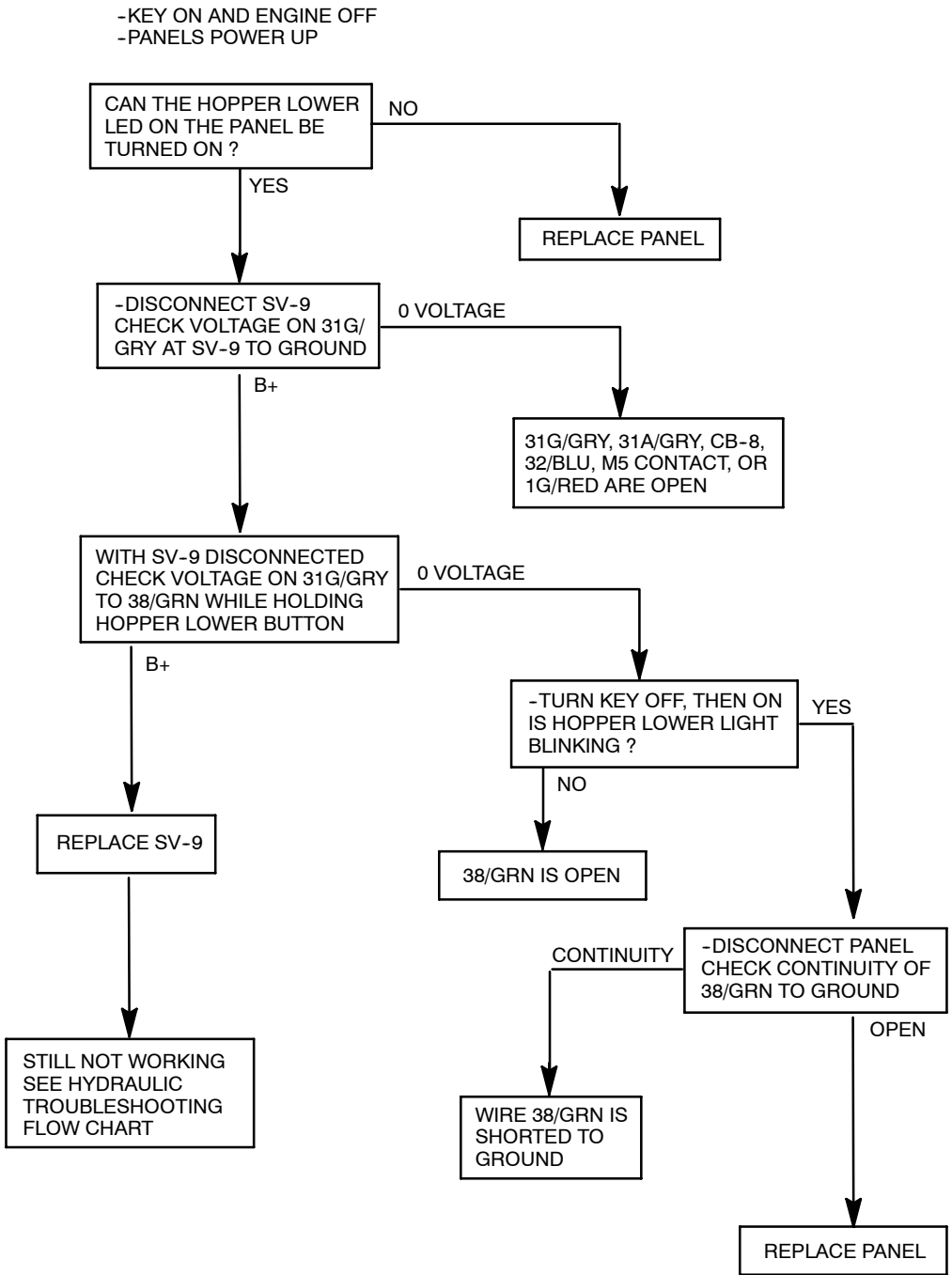

**HOPPER DOOR WILL NOT CLOSE
(FLOW CHART)**

OPERATION:
 -HOPPER DOOR CLOSE IS SELECTED ON PANEL
 -SV-16 IS TURNED ON MOMENTARILY
 -HOPPER DOOR IS CLOSED
NOTE: HOPPER DOOR CLOSED IS SELECTED AUTOMATICALLY AT POWER UP AND WHEN SWEEP IS TURNED OFF
 -DOOR CLOSES FOR 8 SECONDS IN LOW ENGINE SPEED
 -DOOR CLOSES FOR 3 SECONDS IN HIGH ENGINE SPEED

-KEY ON AND ENGINE OFF
 -PANELS POWER UP

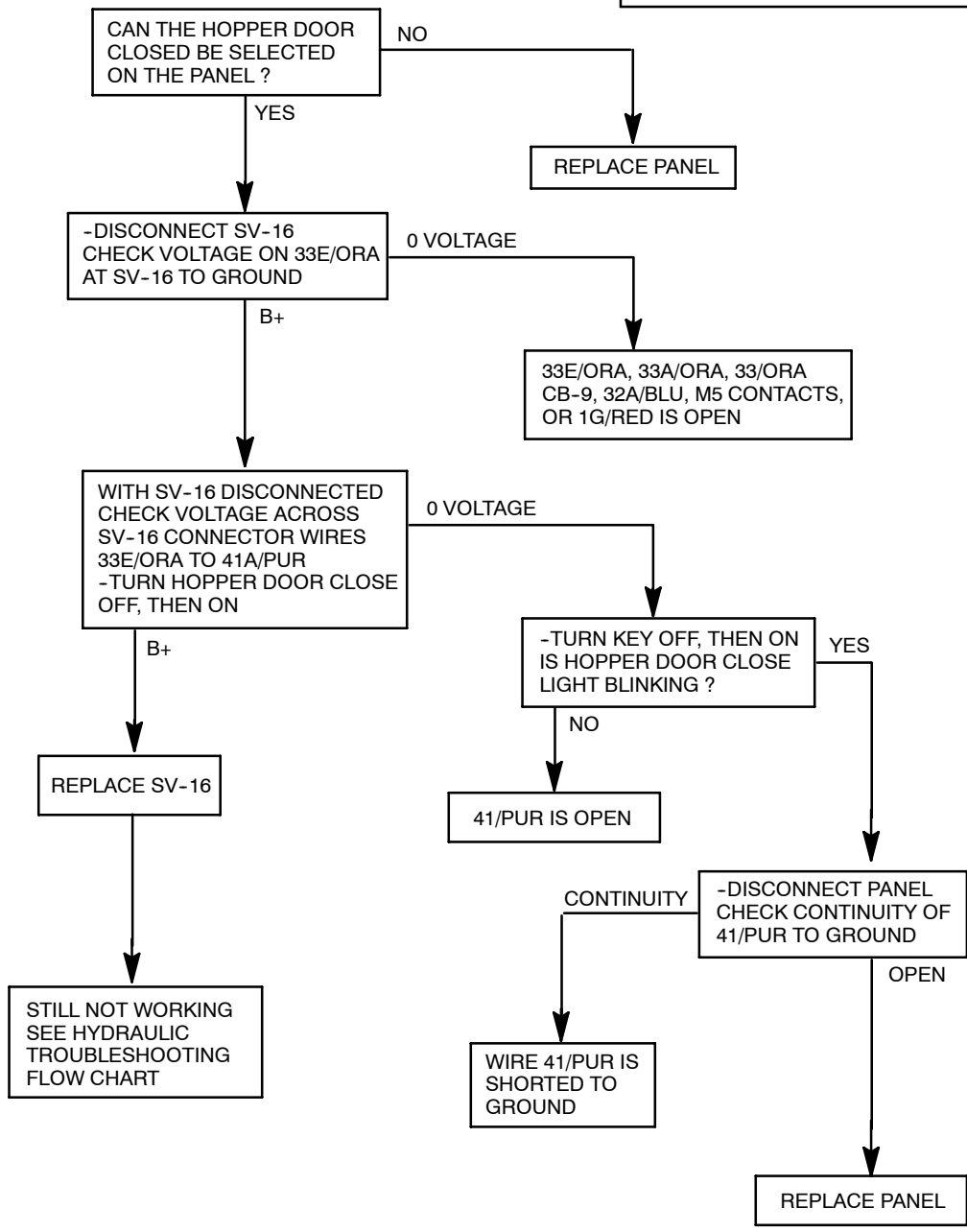

HOPPER DOOR WILL NOT OPEN (SCHEMATIC)

OPERATION:
 -HOPPER DOOR CLOSE IS TURNED OFF ON PANEL
 -SV-17 IS TURNED ON MOMENTARILY
 -HOPPER DOOR IS OPENED
NOTE: HOPPER DOOR OPEN IS SELECTED AUTOMATICALLY WHEN SWEEP IS TURNED ON
 -DOOR OPENS FOR 8 SECONDS IN LOW ENGINE SPEED
 -DOOR OPENS FOR 3 SECONDS IN HIGH ENGINE SPEED

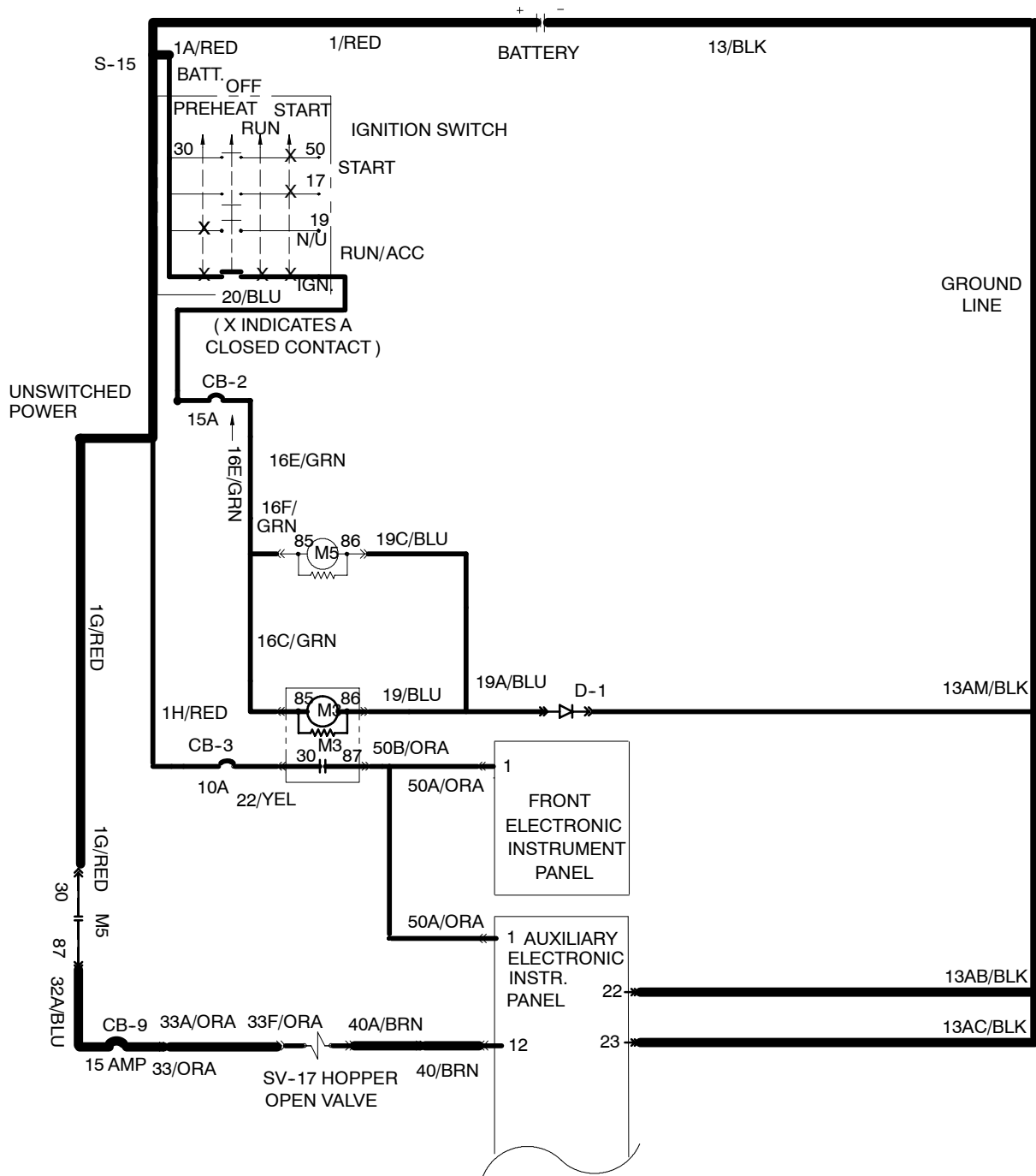

**HOPPER DOOR WILL NOT OPEN
(FLOW CHART)**

OPERATION:
 -HOPPER DOOR CLOSE IS TURNED OFF ON PANEL
 -SV-17 IS TURNED ON MOMENTARILY
 -HOPPER DOOR IS OPENED
NOTE: HOPPER DOOR OPEN IS SELECTED AUTOMATICALLY WHEN SWEEP IS TURNED ON
 -DOOR OPENS FOR 8 SECONDS IN LOW ENGINE SPEED
 -DOOR OPENS FOR 3 SECONDS IN HIGH ENGINE SPEED

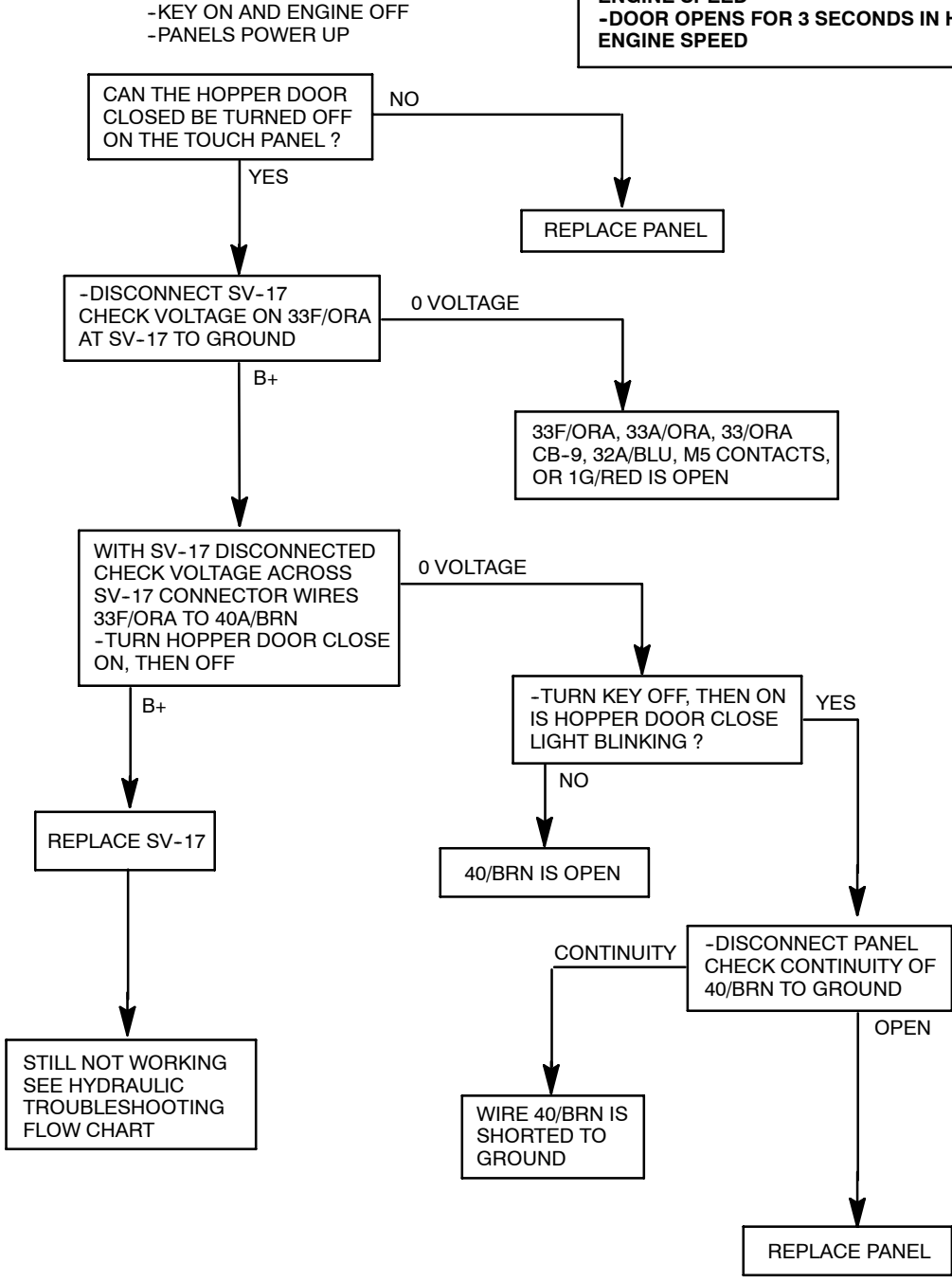

ENGINE COOLING FAN NOT OPERATING (SCHEMATIC)

OPERATION:
 -HIGH ENGINE SPEED SELECTED
 -ENGINE SPEED IS SENSED ON SWEEP PANEL WHEN PIN 15 IS LESS THEN 1 VDC
 -PIN 17 IS PULLED LOW
 -SV-2 TURNS ON

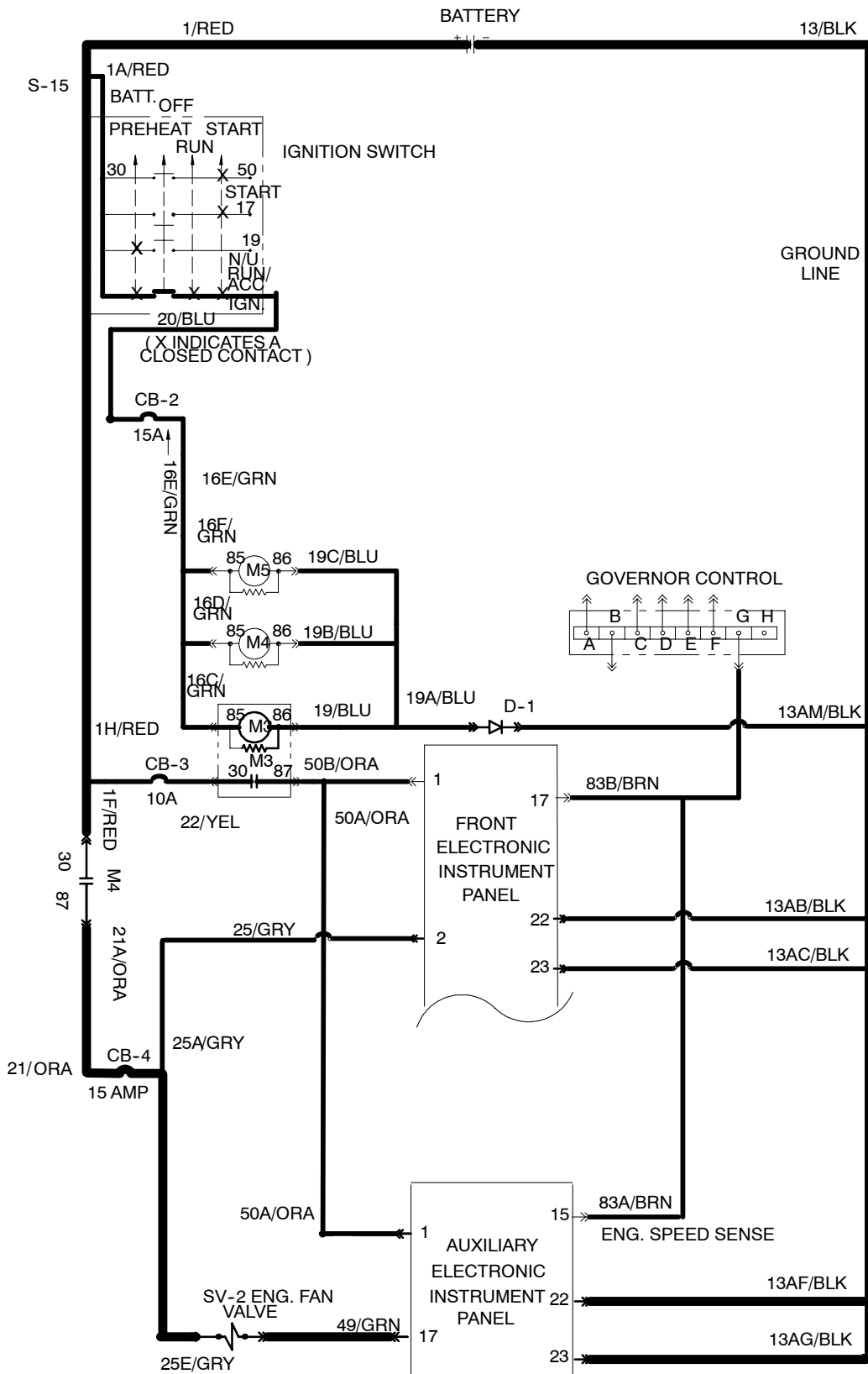

ENGINE COOLING FAN NOT OPERATING (FLOW CHART)

OPERATION:
 -HIGH ENGINE SPEED SELECTED
 -ENGINE SPEED IS SENSED ON SWEEP PANEL WHEN PIN 15 IS LESS THEN 1 VDC
 -PIN 17 IS PULLED LOW
 -SV-2 TURNS ON

-KEY ON AND ENGINE OFF
 -PANELS POWER UP

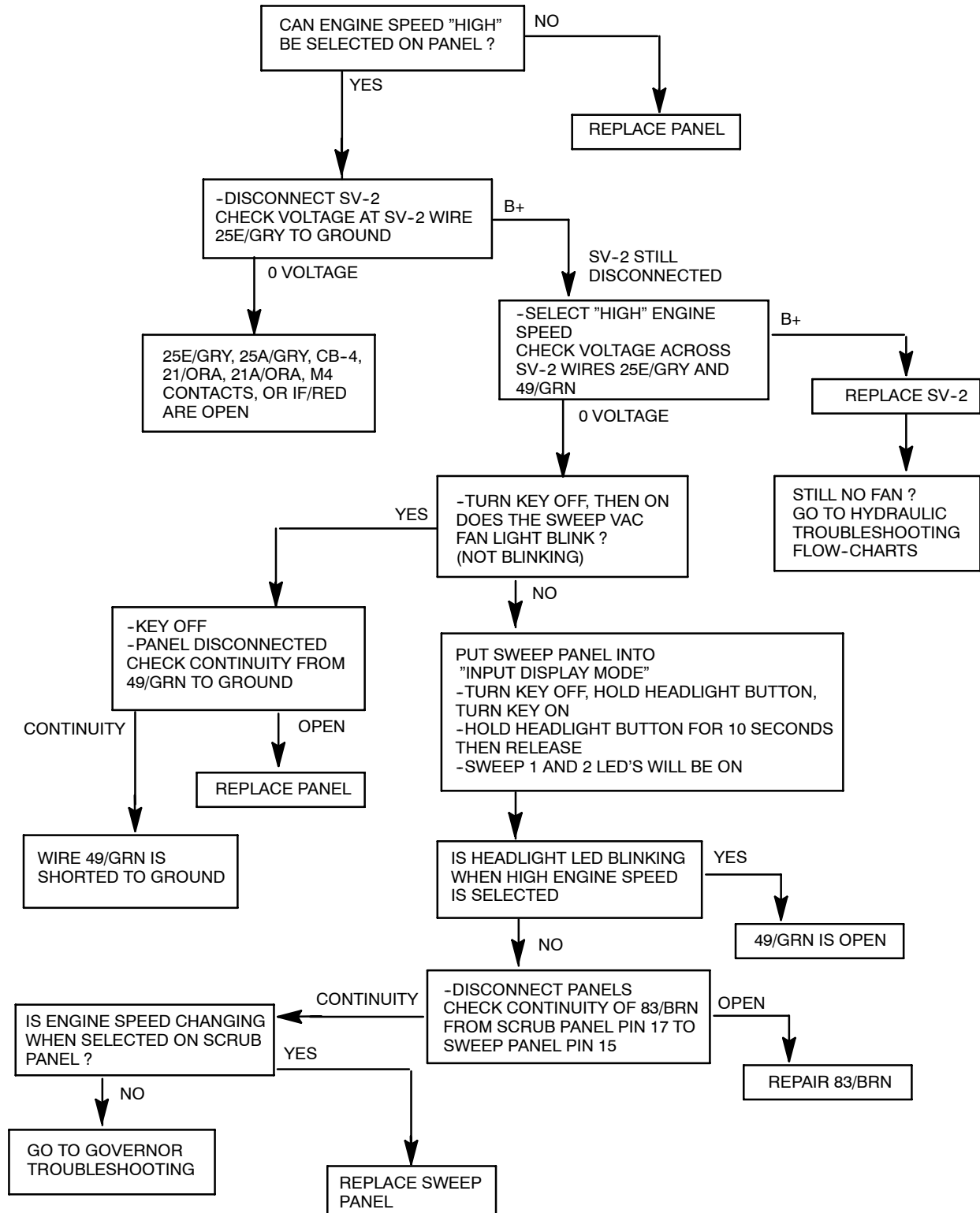

ENGINE OIL PRESSURE WARNING LIGHT WILL NOT TURN ON OR OFF (SCHEMATIC)

OPERATION:
 - (PIN 15) IS PULLED TO GROUND THROUGH S-2 WHEN OIL PRESSURE IS HIGH ENOUGH
 - OIL LIGHT TURNS OFF

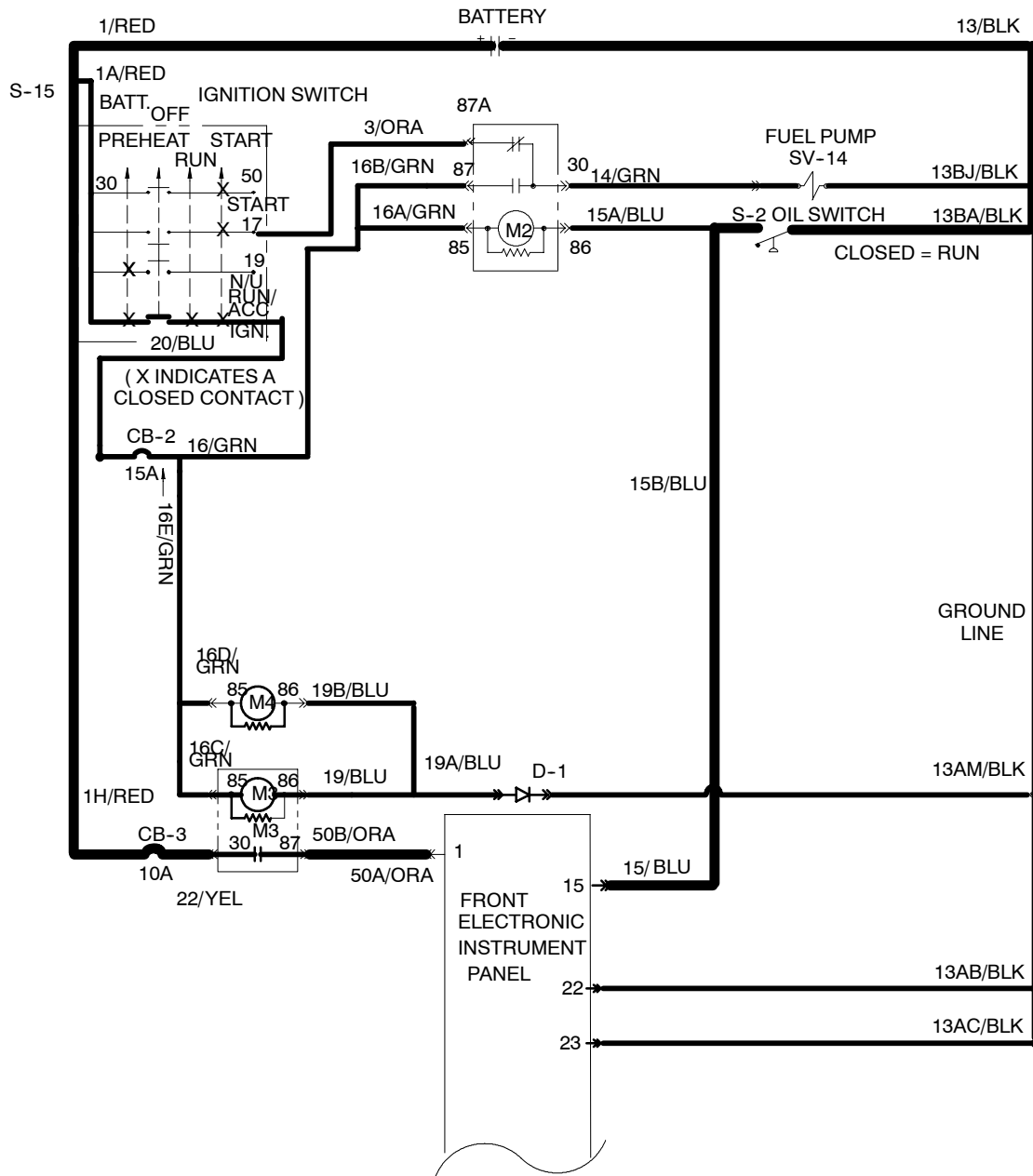

ENGINE OIL PRESSURE WARNING LIGHT WILL NOT TURN ON (FLOW CHART)

OPERATION:
 -(PIN 15) IS PULLED TO GROUND THROUGH S-2 WHEN OIL PRESSURE IS HIGH ENOUGH
 -OIL LIGHT TURNS OFF

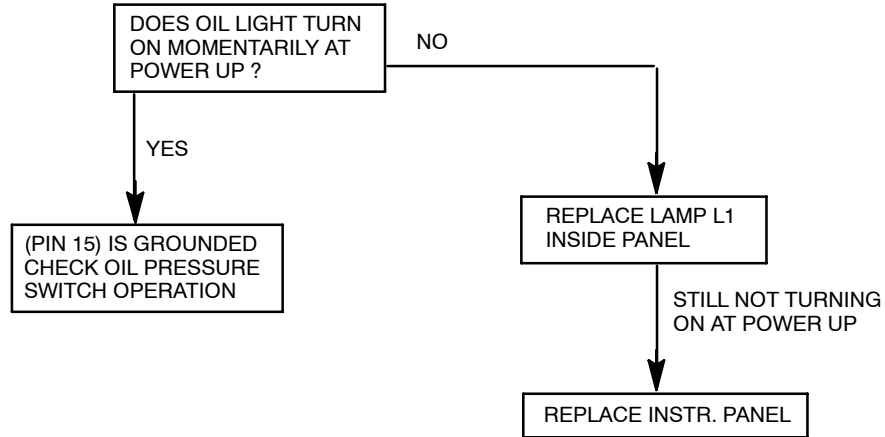

ENGINE OIL PRESSURE WARNING LIGHT WILL NOT TURN OFF (FLOW CHART)

OPERATION:
 -(PIN 15) IS PULLED TO GROUND THROUGH S-2 WHEN OIL PRESSURE IS HIGH ENOUGH
 -OIL LIGHT TURNS OFF

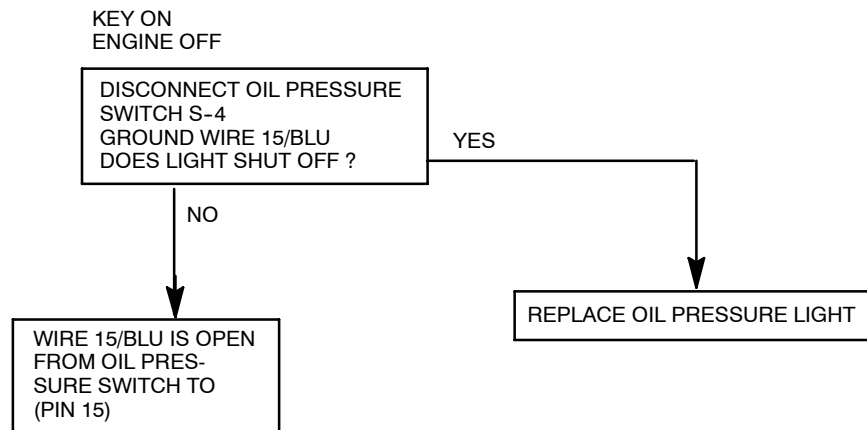

**ENGINE TEMPERATURE LIGHT
WILL NOT TURN ON OR OFF
(SCHEMATIC)**

OPERATION:
 -WHEN ENGINE COOLANT EXCEEDS
 225 DEGREE F. SE-2 =<80 OHMS
 -COOLANT LIGHT TURNS ON

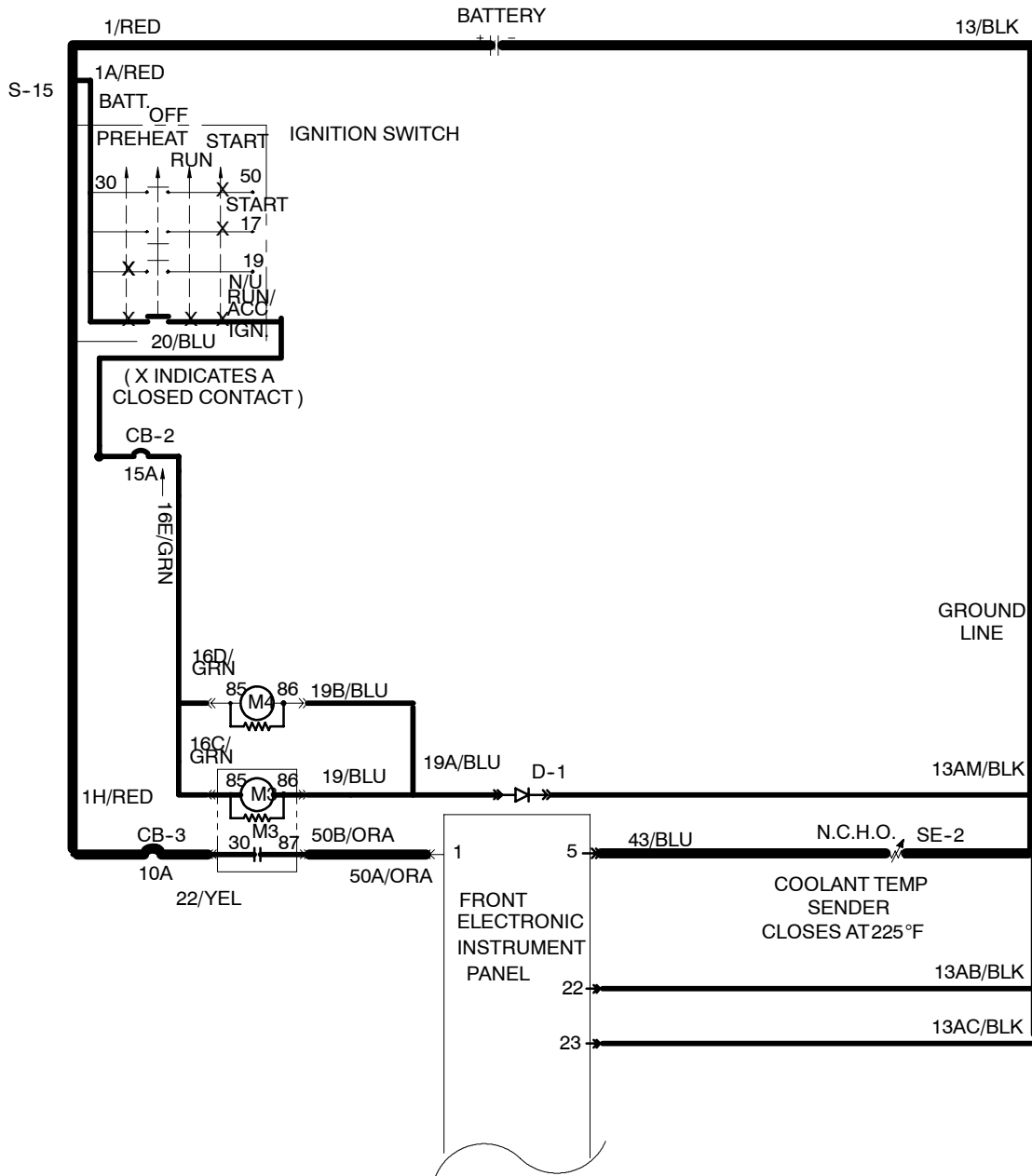

**ENGINE TEMPERATURE LIGHT
WILL NOT TURN ON
(FLOW CHART)**

OPERATION:
-WHEN ENGINE COOLANT EXCEEDS
225 DEGREE F. SE-2 =-80 OHMS
-COOLANT LIGHT TURNS ON

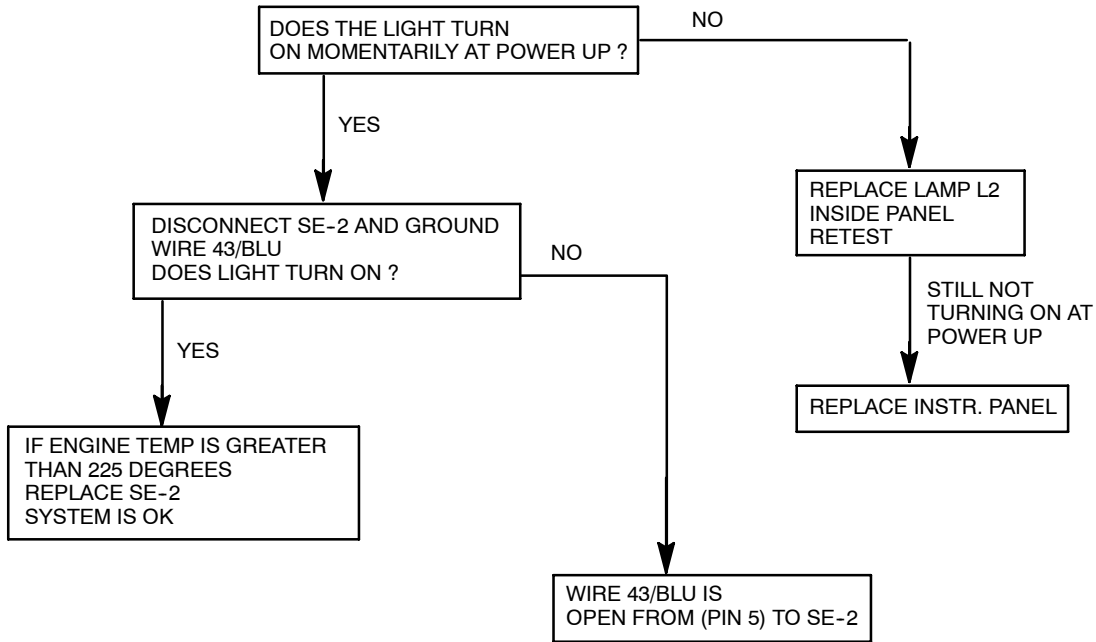

**ENGINE TEMPERATURE LIGHT
WILL NOT TURN OFF
(FLOW CHART)**

OPERATION:
-WHEN ENGINE COOLANT EXCEEDS
225 DEGREE F. SE-2 =-80 OHMS
-COOLANT LIGHT TURNS ON

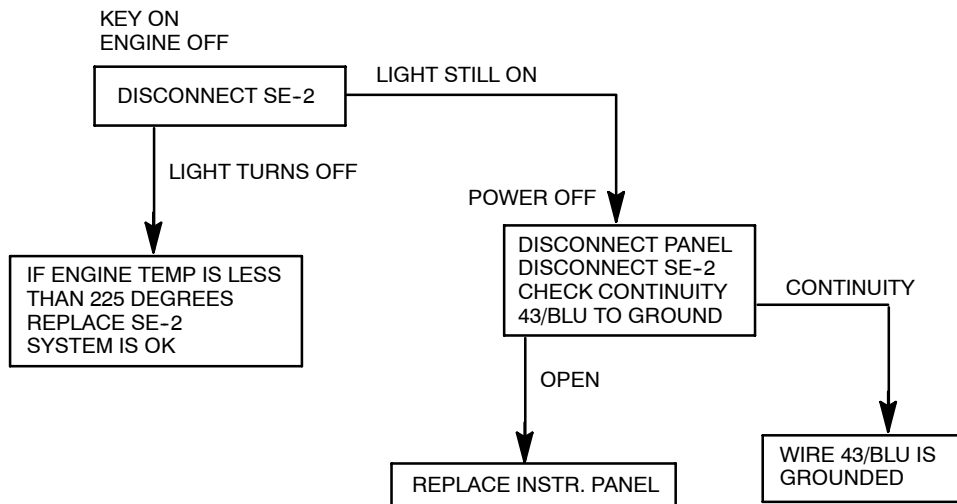

ALTERNATOR / BATTERY WARNING LIGHT WILL NOT TURN ON (SCHEMATIC)

OPERATION:
 -CONNECTION L2 ON ALTERNATOR GOES TO BATTERY POSITIVE WHEN ALTERNATOR IS TURNED ON
 -BATTERY POSITIVE AT (PIN 14) TURNS OFF THE ALTERNATOR / BATTERY INDICATOR

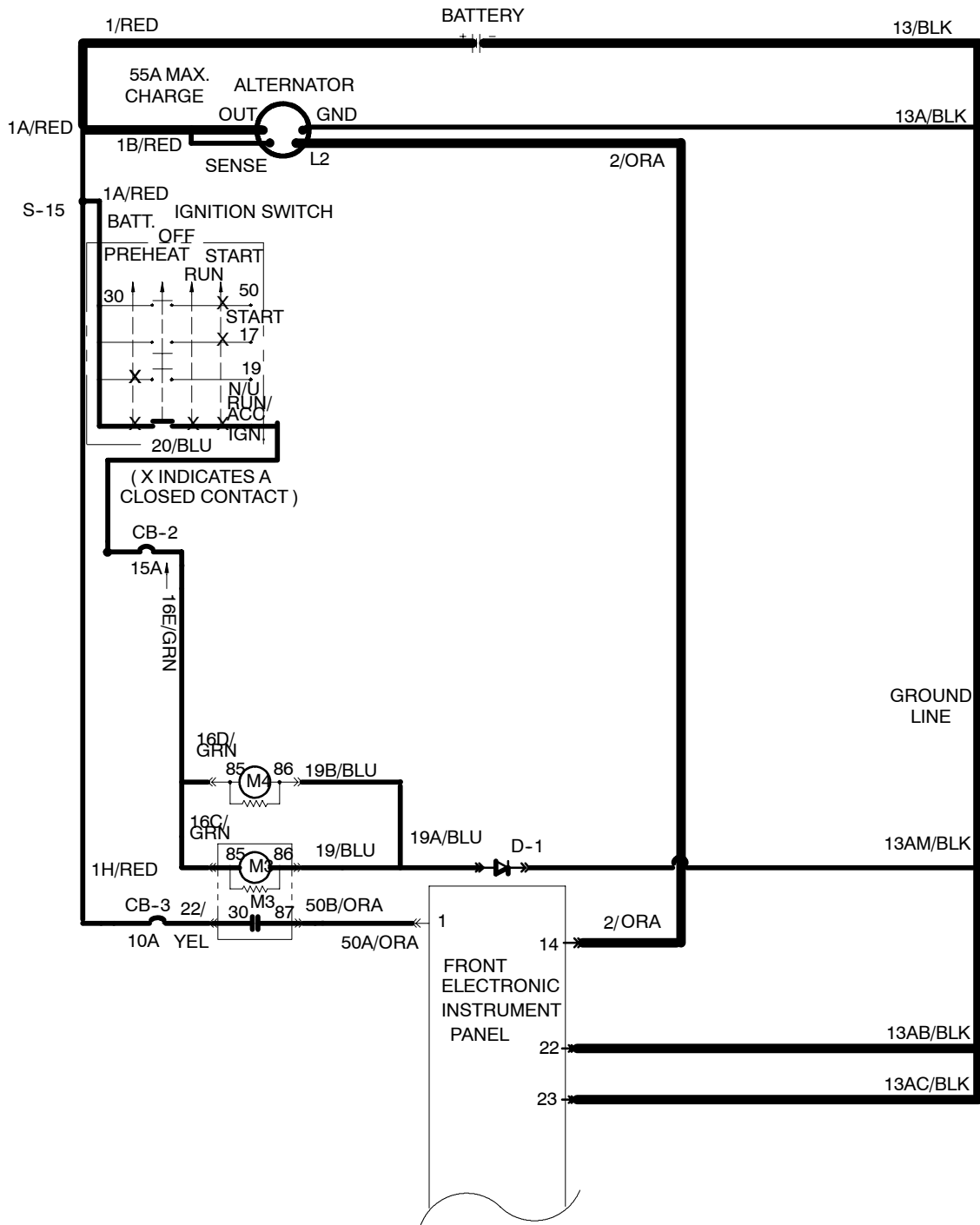

ALTERNATOR / BATTERY WARNING LIGHT WILL NOT TURN ON (FLOW CHART)

OPERATION:
-CONNECTION L2 ON ALTERNATOR GOES TO BATTERY POSITIVE WHEN ALTERNATOR IS TURNED ON
-BATTERY POSITIVE AT (PIN 14) TURNS OFF THE ALTERNATOR / BATTERY INDICATOR

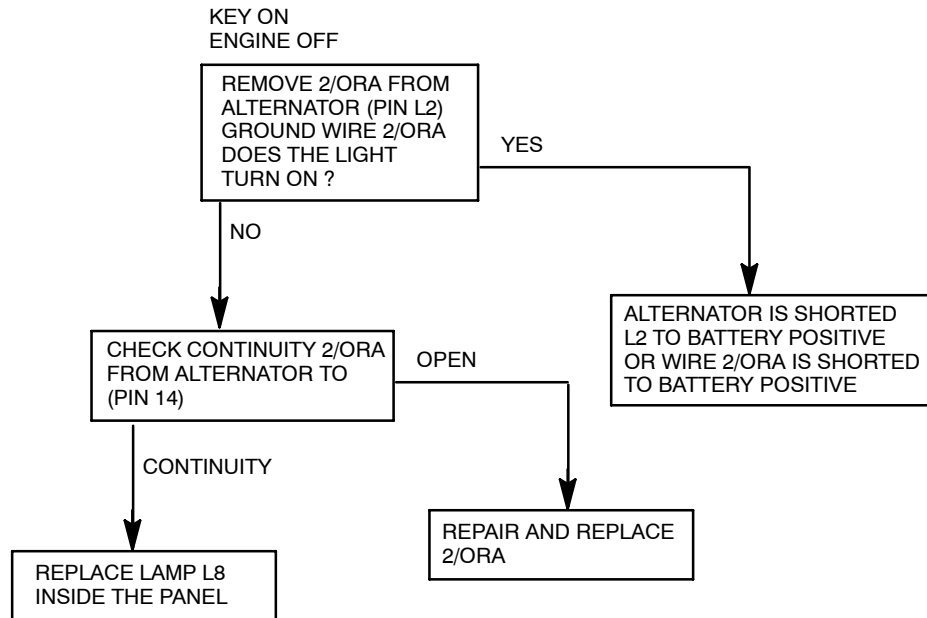

ALTERNATOR / BATTERY WARNING LIGHT STAYS ON WHEN ENGINE IS RUNNING (SCHEMATIC)

OPERATION:
 -CONNECTION L2 ON ALTERNATOR GOES TO BATTERY POSITIVE WHEN ALTERNATOR IS TURNED ON
 -BATTERY POSITIVE AT (PIN 14) TURNS OFF THE ALTERNATOR / BATTERY INDICATOR

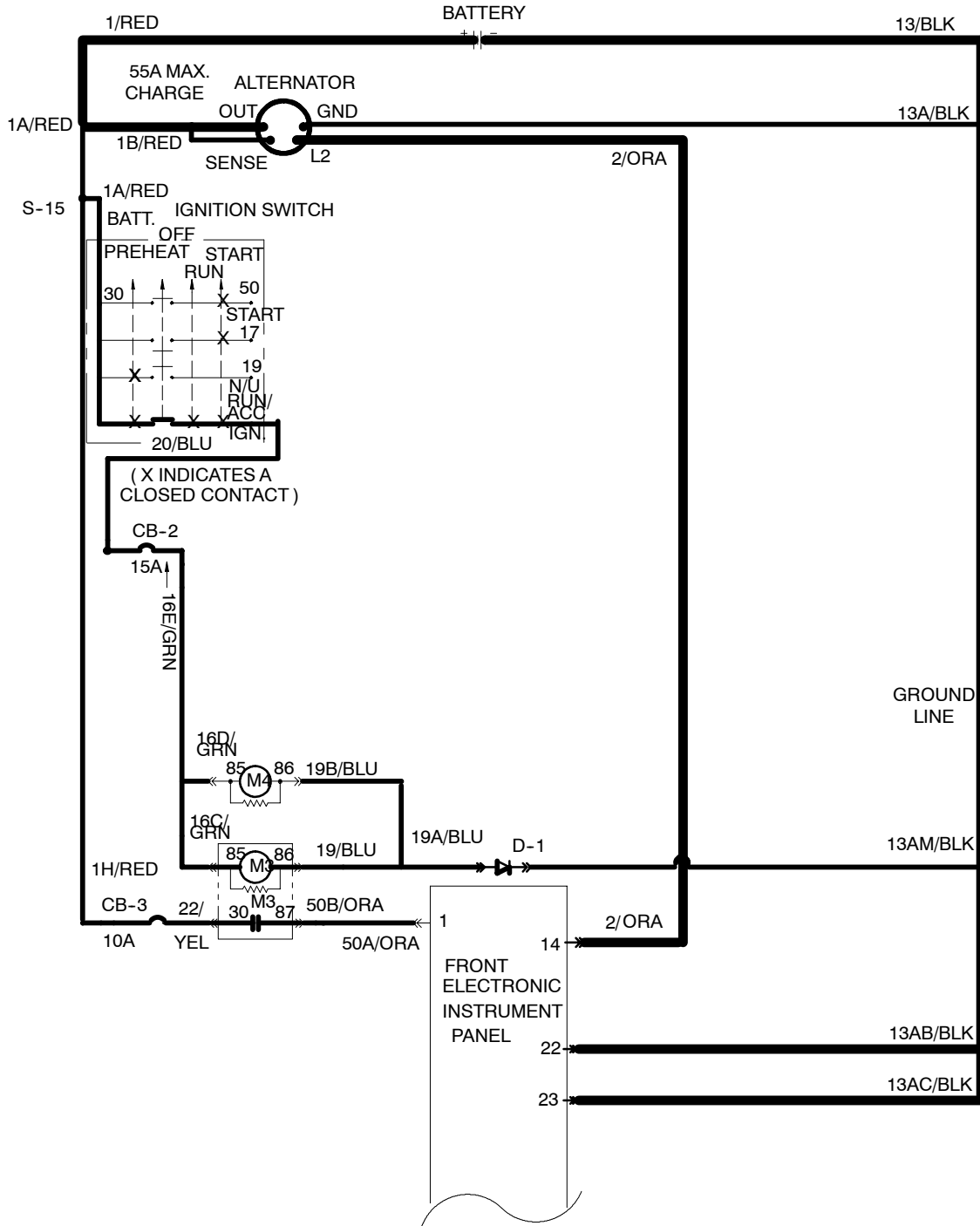

ALTERNATOR / BATTERY WARNING LIGHT STAYS ON WHEN ENGINE IS RUNNING (FLOW CHART)

OPERATION:
 -CONNECTION L2 ON ALTERNATOR GOES TO BATTERY POSITIVE WHEN ALTERNATOR IS TURNED ON
 -BATTERY POSITIVE AT (PIN 14) TURNS OFF THE ALTERNATOR / BATTERY INDICATOR

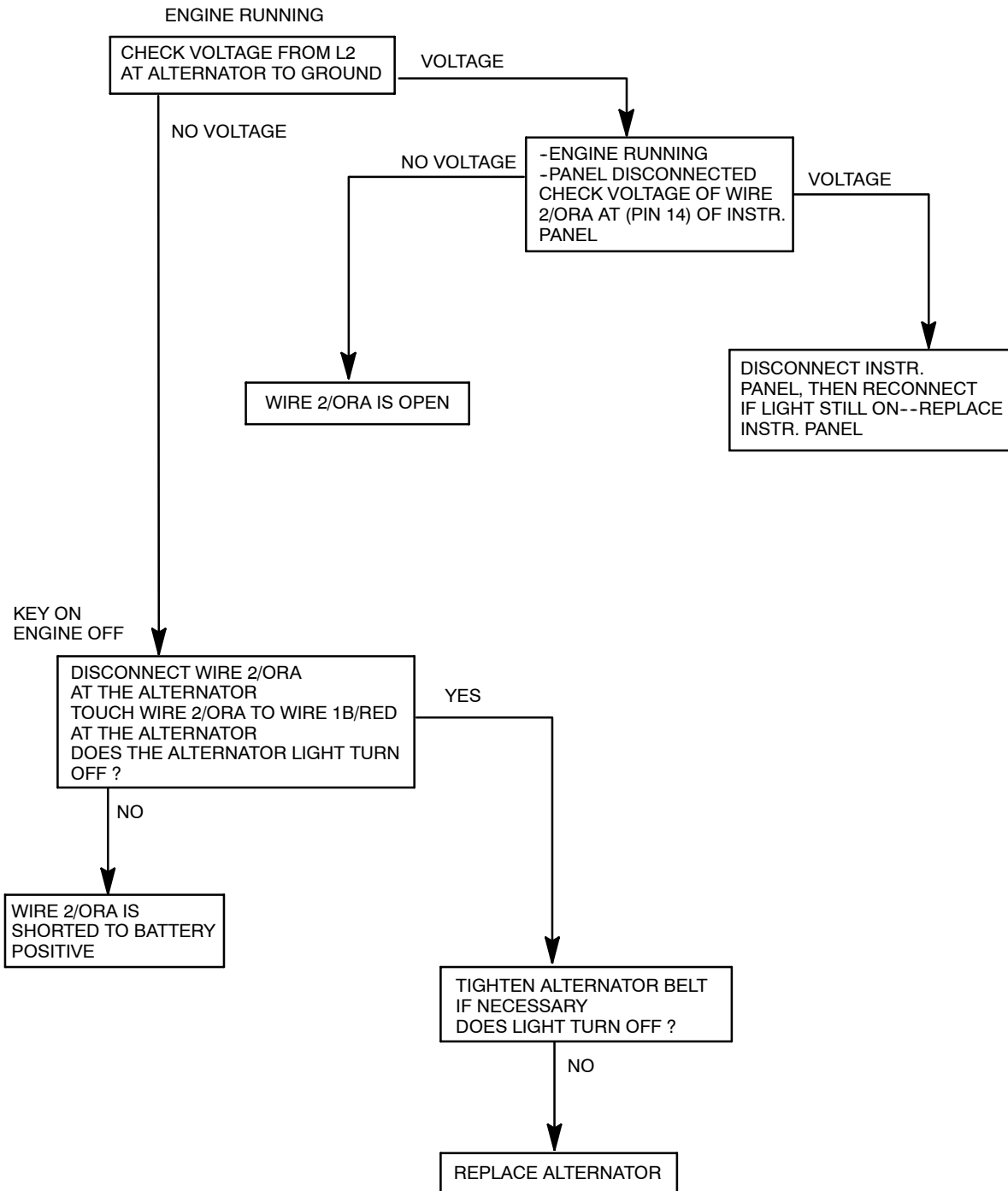

**FUEL GAUGE NOT OPERATING
(GAS AND DIESEL)
(SCHEMATIC)**

OPERATION:
 -SE-1 GREATER THE 90 OHMS=FULL TANK
 -SE-1 LESS THAN 10 OHMS=EMPTY TANK
 -NOTE; IF SE-1 > 500OHMS OR < 10 OHMS AT
 POWER UP THE PANEL GOES TO LP MODE
 (NO LIGHTS FOR FULL, 2 LIGHTS FOR EMPTY)

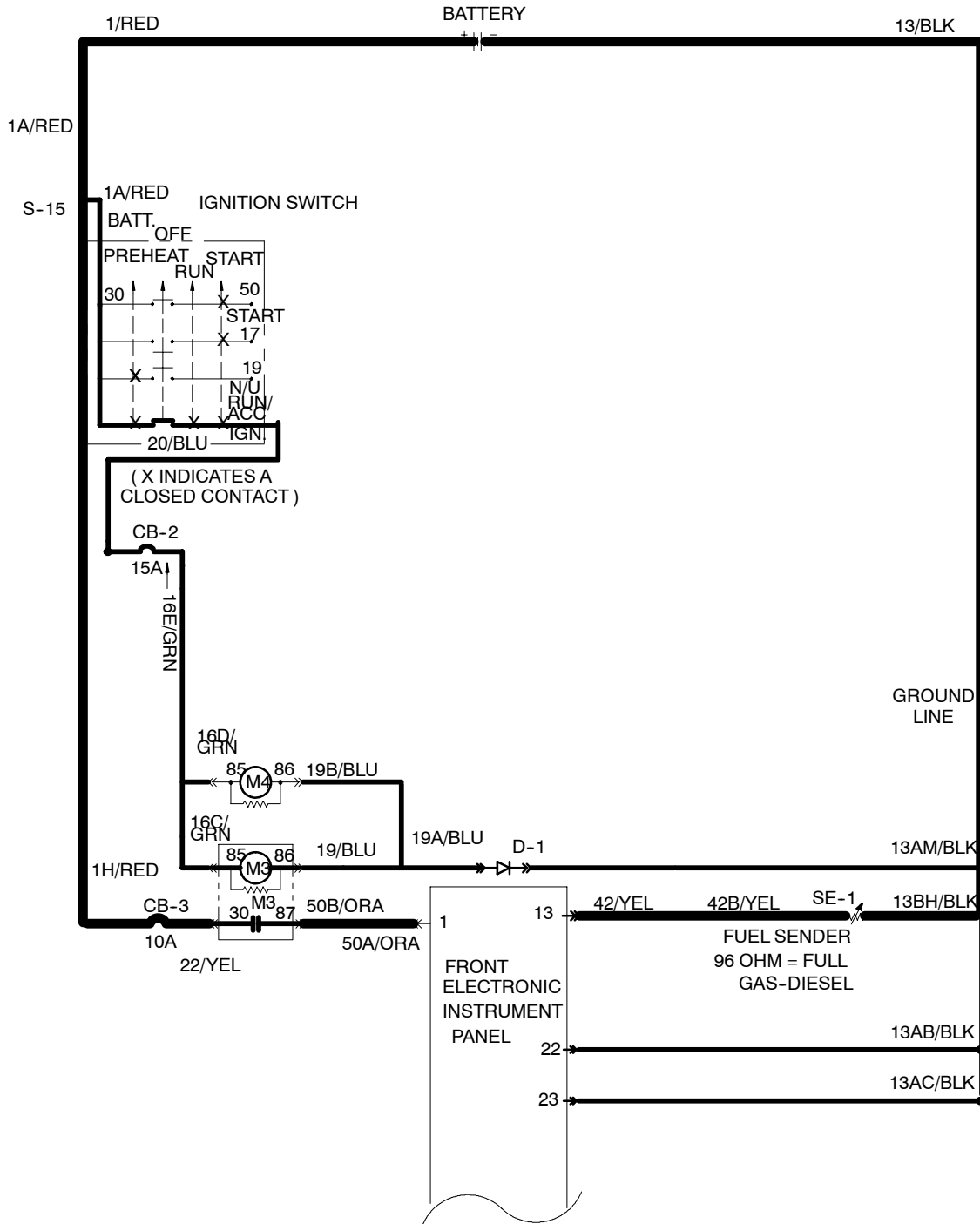

**FUEL GAUGE NOT OPERATING
(GAS AND DIESEL)
(FLOW CHART)**

OPERATION:
 -SE-1 GREATER THE 90 OHMS=FULL TANK
 -SE-1 LESS THAN 10 OHMS=EMPTY TANK
 -NOTE; IF SE-1 > 500OHMS OR < 10 OHMS AT
 POWER UP THE PANEL GOES TO LP MODE
 (NO LIGHTS FOR FULL, 2 LIGHTS FOR EMPTY)

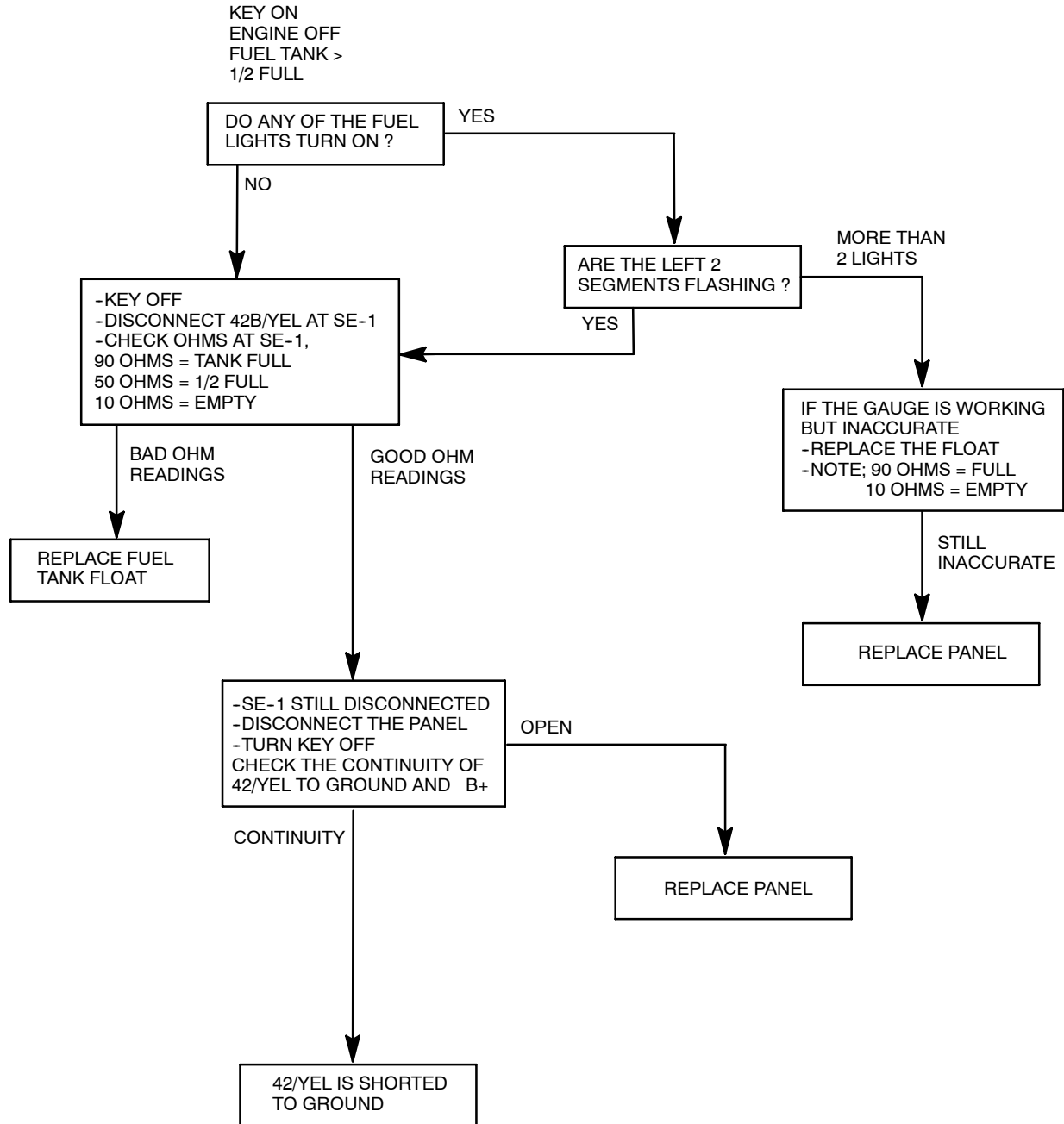

**FUEL GAUGE (LPG)
(SCHEMATIC)**

OPERATION:
 -S-6 IS OPEN = GAUGE IS OFF
 -S-6 IS CLOSED = LEFT 2 SEGMENTS OF GAUGE FLASH
 -SE-1 IS NOT ON MACHINE
 -NOTE; IF SE-1 > 500OHMS OR < 10 OHMS AT POWER UP THE PANEL GOES TO LP MODE (NO LIGHTS FOR FULL, 2 LIGHTS FOR EMPTY)

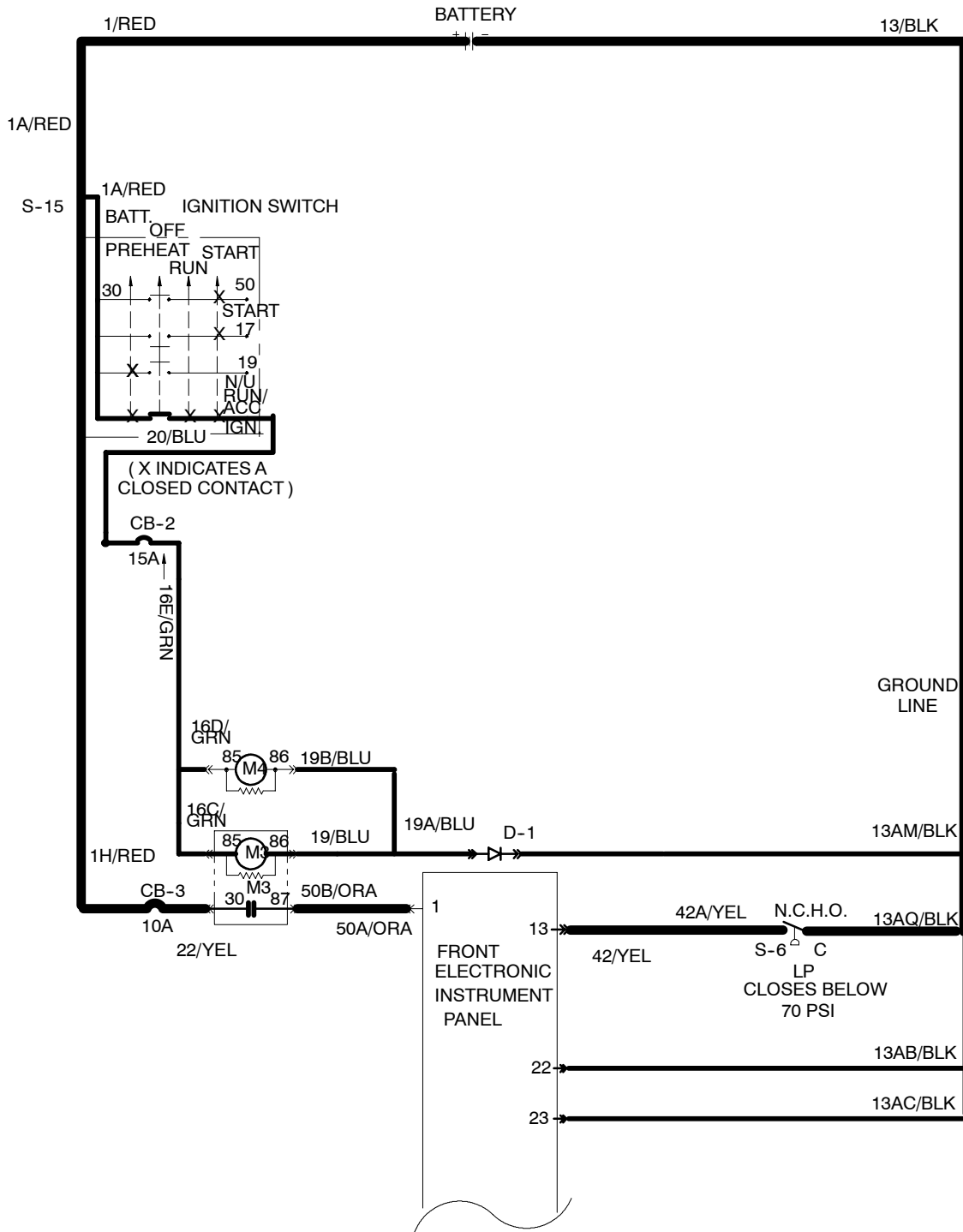

**FUEL GAUGE (LPG)
(FLOW CHART)**

OPERATION:
 -S-6 IS OPEN = GAUGE IS OFF
 -S-6 IS CLOSED = LEFT 2 SEGMENTS OF GAUGE FLASH
 -SE-1 IS NOT ON MACHINE
 -NOTE; IF SE-1 > 500OHMS OR < 10 OHMS AT POWER UP THE PANEL GOES TO LP MODE (NO LIGHTS FOR FULL, 2 LIGHTS FOR EMPTY)

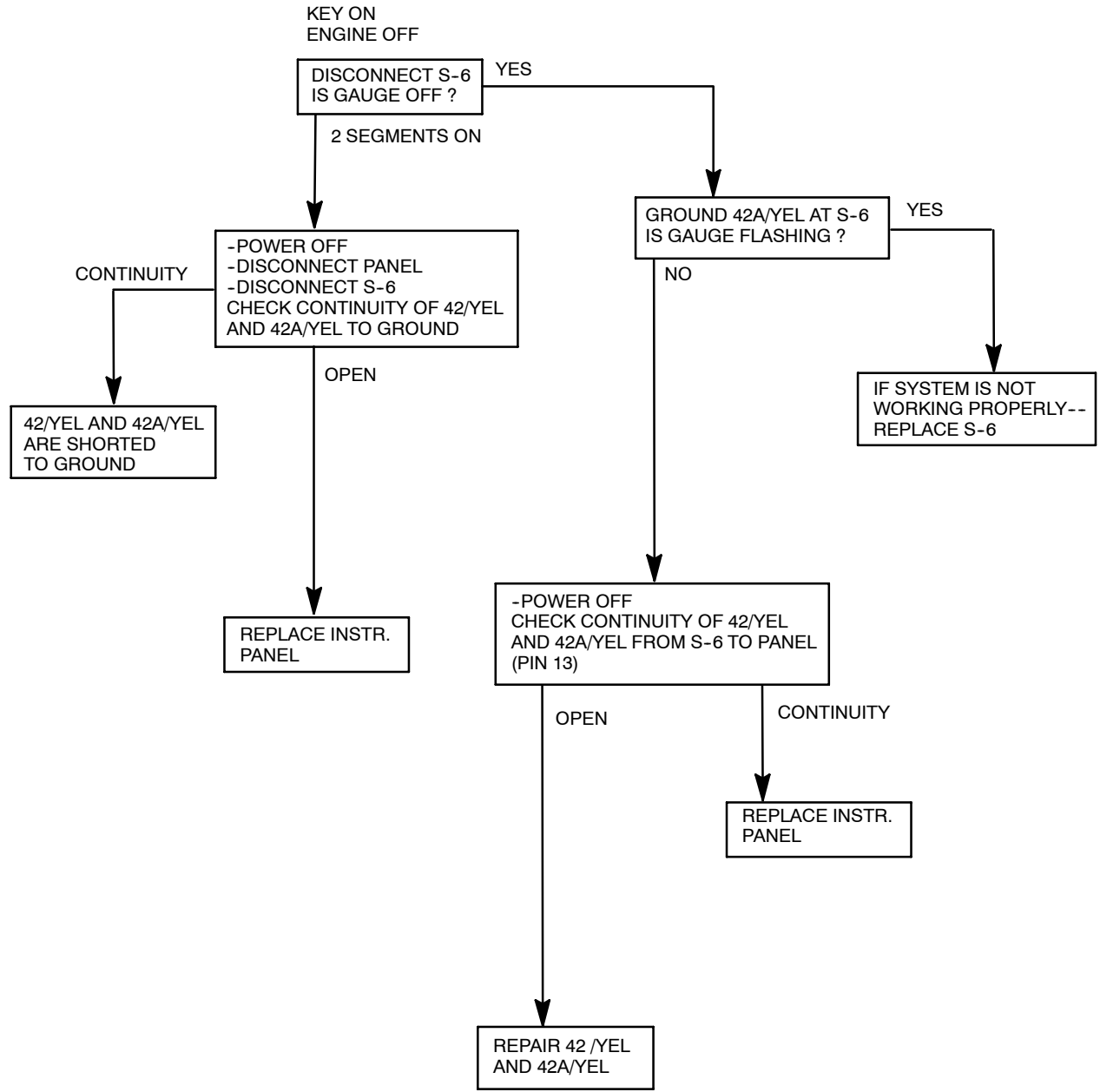

**HEAD LIGHTS WILL NOT TURN ON
(SCHEMATIC)**

OPERATION:
 -HEADLIGHT SWITCH IS SELECTED
 ON PANEL
 -M7 IS TURNED ON
 -CONTACT OF M7 SUPPLIES VOLTAGE
 TO HEADLIGHTS

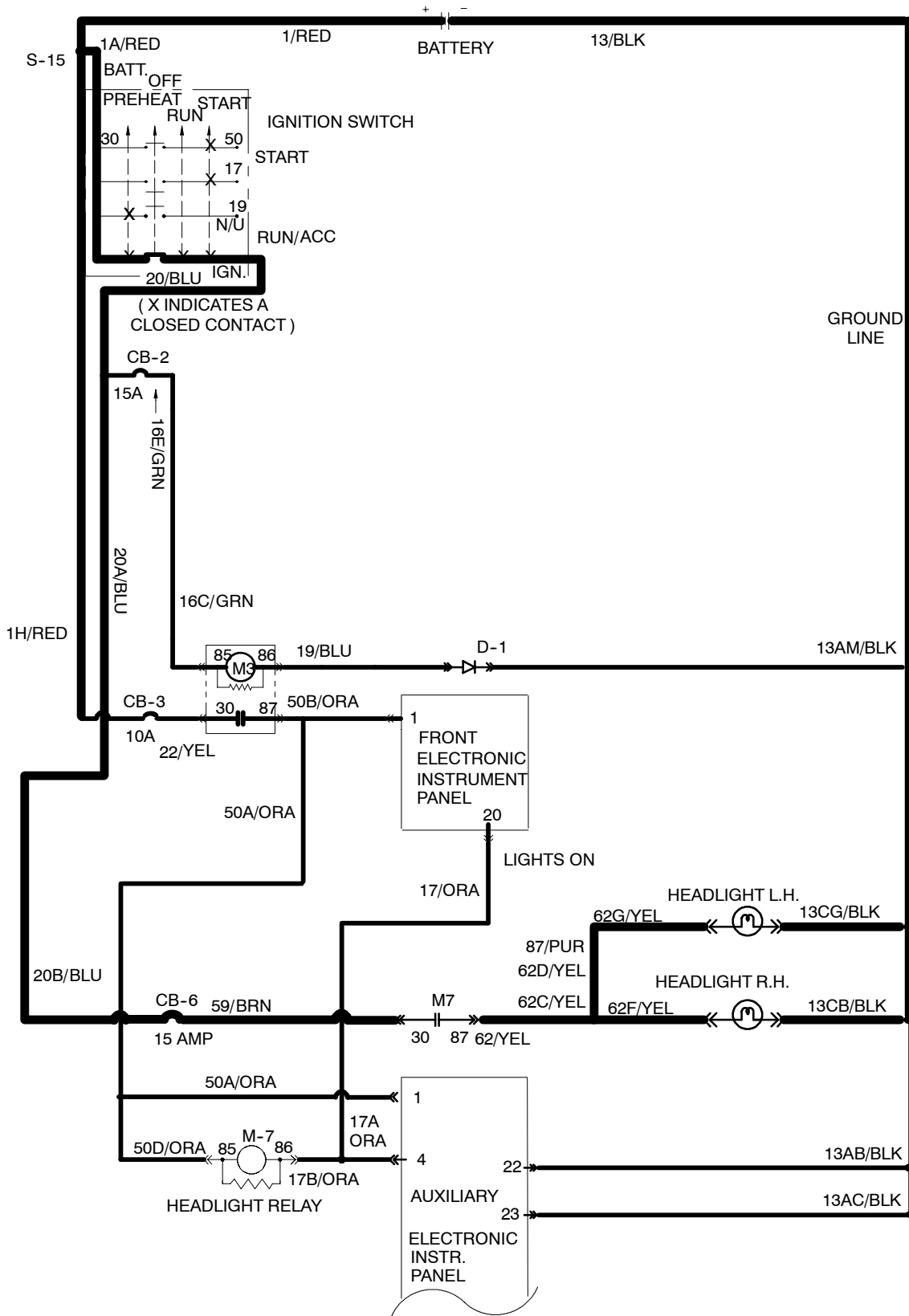

HEAD LIGHTS WILL NOT TURN ON (FLOW CHART)

OPERATION:
 - HEADLIGHT SWITCH IS SELECTED ON PANEL
 - M7 IS TURNED ON
 - CONTACT OF M7 SUPPLIES VOLTAGE TO HEADLIGHTS

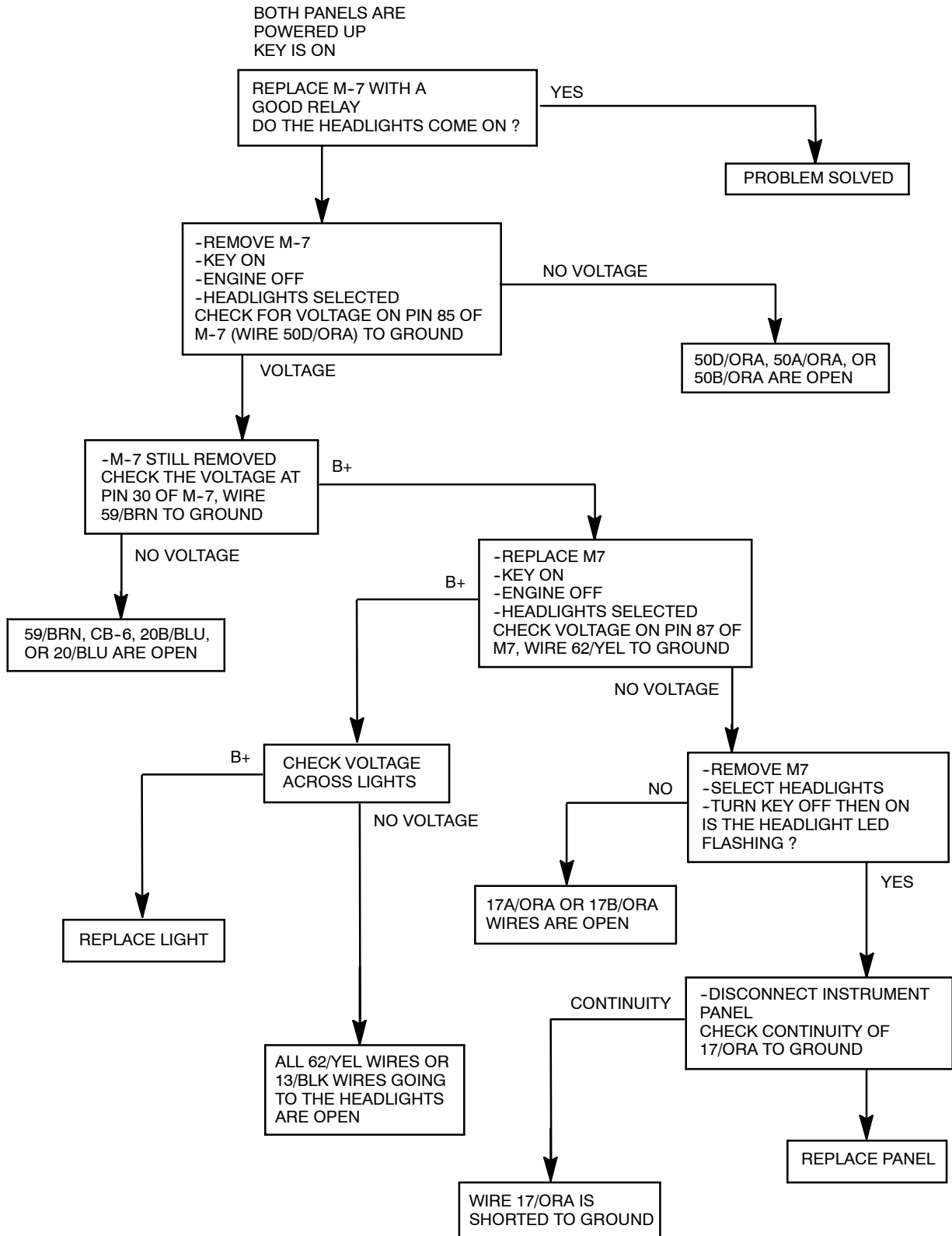

HAZARD LIGHT WILL NOT TURN ON (SCHEMATIC)

OPERATION:
 -HAZARD LIGHT SWITCH IS SELECTED ON PANEL
 -M9 IS TURNED ON
 -CONTACT OF M9 SUPPLIES VOLTAGE TO HAZARD LIGHT

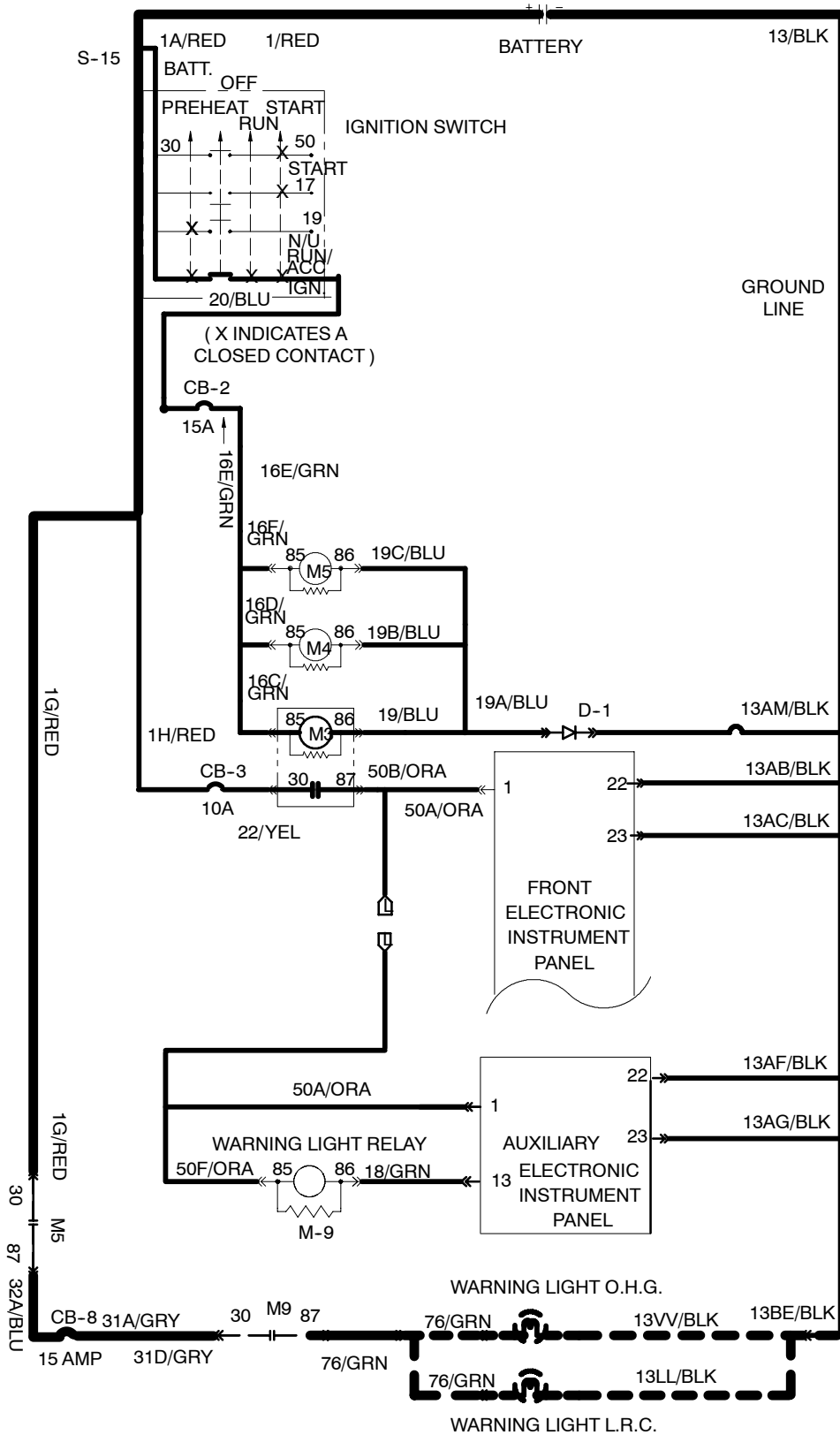

HAZARD LIGHT WILL NOT TURN ON (FLOW CHART)

OPERATION:
 -HAZARD LIGHT SWITCH IS SELECTED ON PANEL
 -M9 IS TURNED ON
 -CONTACT OF M9 SUPPLIES VOLTAGE TO HAZARD LIGHT

BOTH PANELS ARE POWERED UP
 KEY IS ON

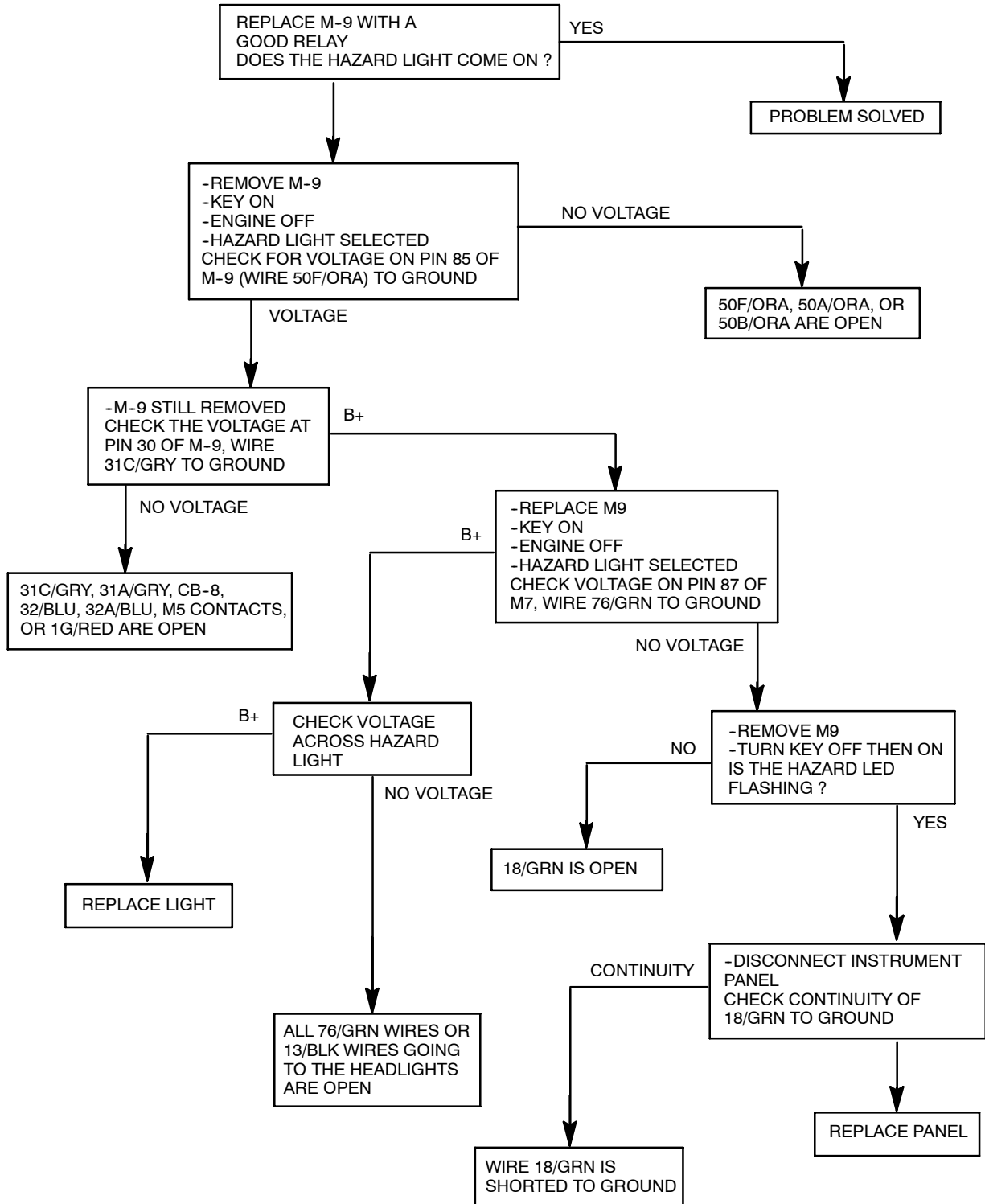

**REVERSE LIGHT OR ALARM
DO NOT TURN ON
(SCHEMATIC)**

OPERATION:
 -S-7 CLOSSES IN REVERSE
 -M-8 WILL TURN ON
 -M-8 CONTACTS SUPPLY VOLTAGE
 TO ALARM AND LIGHT

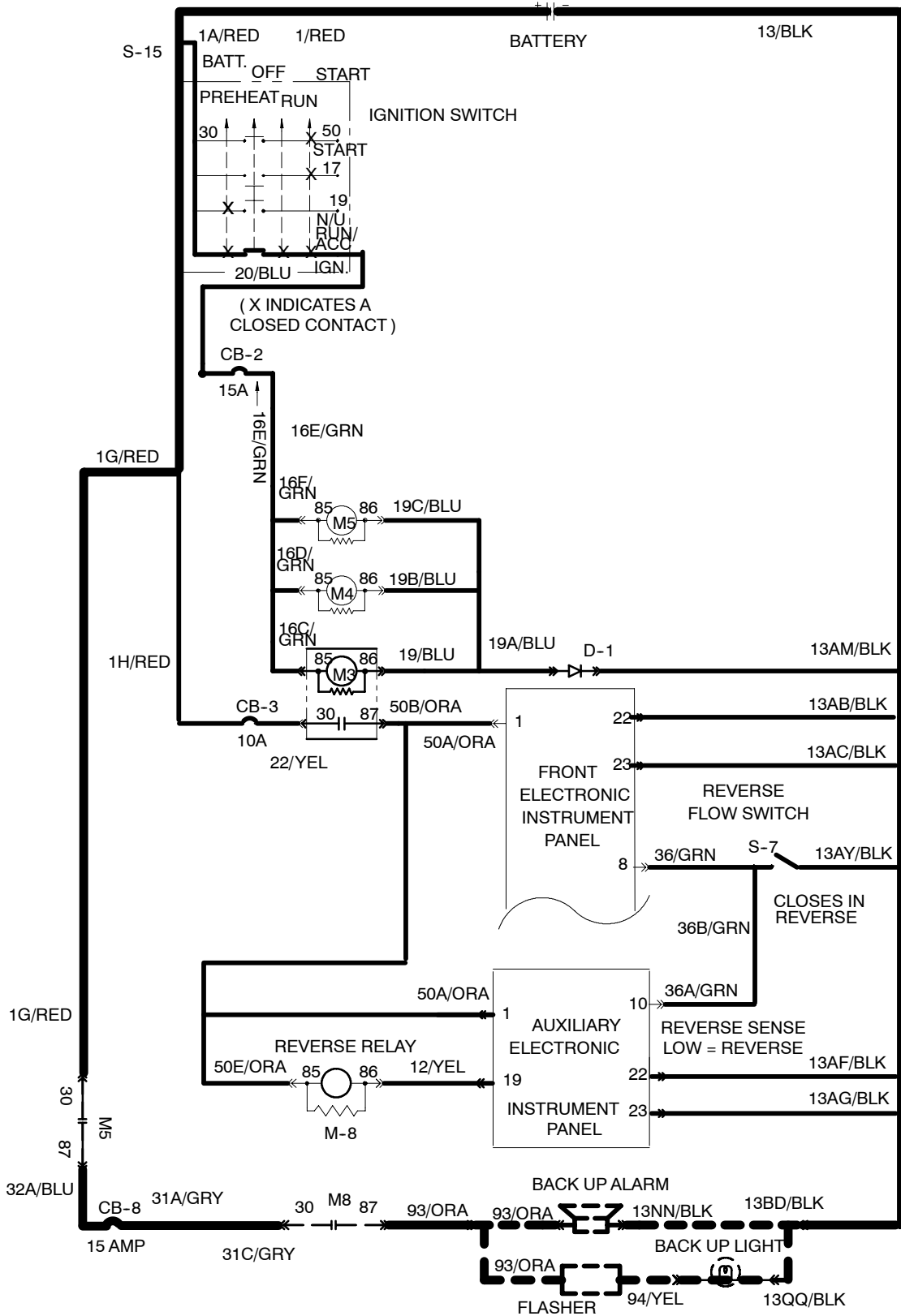

**REVERSE LIGHT OR ALARM
DO NOT TURN ON
(FLOW CHART)**

OPERATION:
 -S-7 CLOSURES IN REVERSE
 -M-8 WILL TURN ON
 -M-8 CONTACTS SUPPLY VOLTAGE
 TO ALARM AND LIGHT

BOTH PANELS POWERED UP

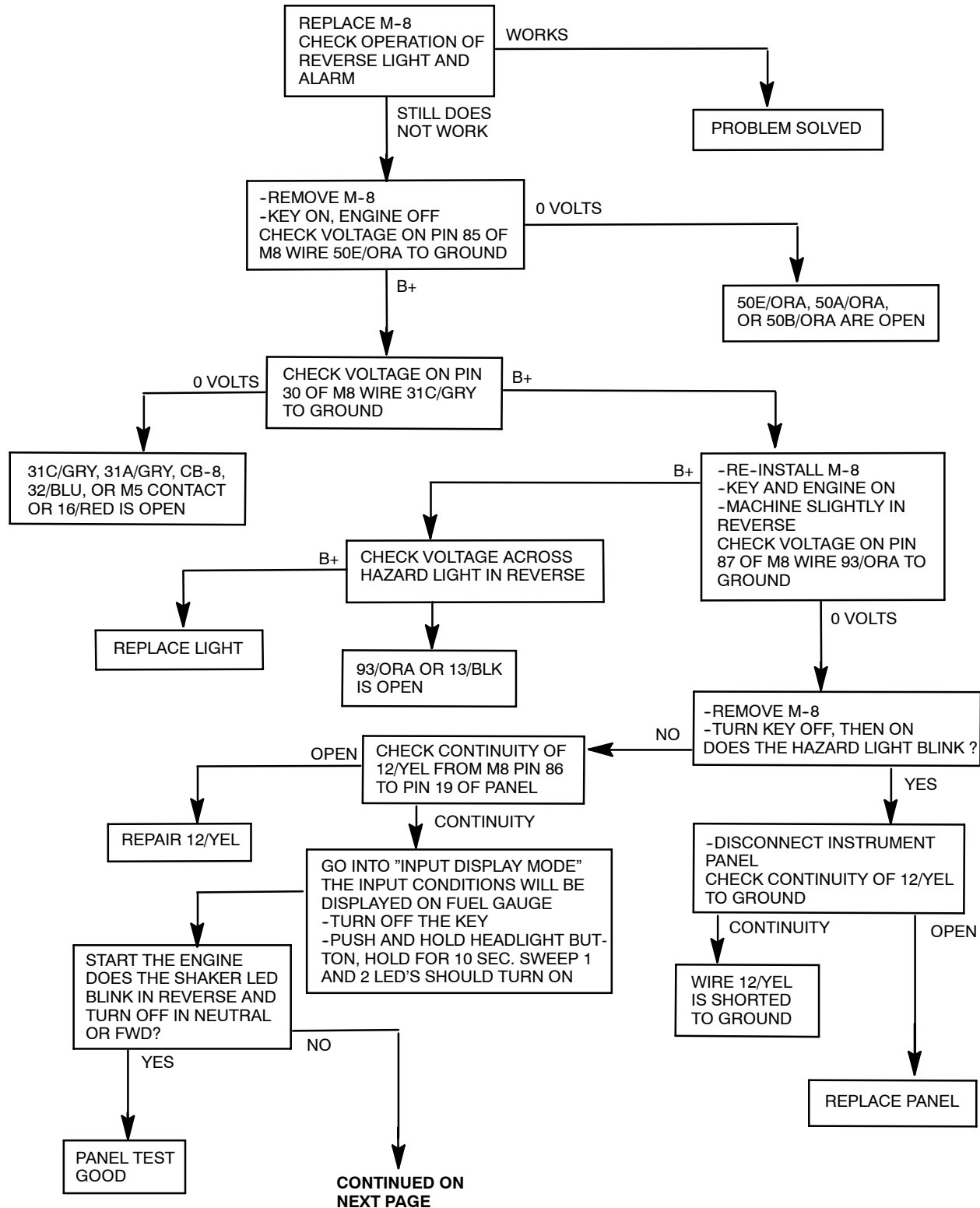

CONTINUED FROM
PREVIOUS PAGE

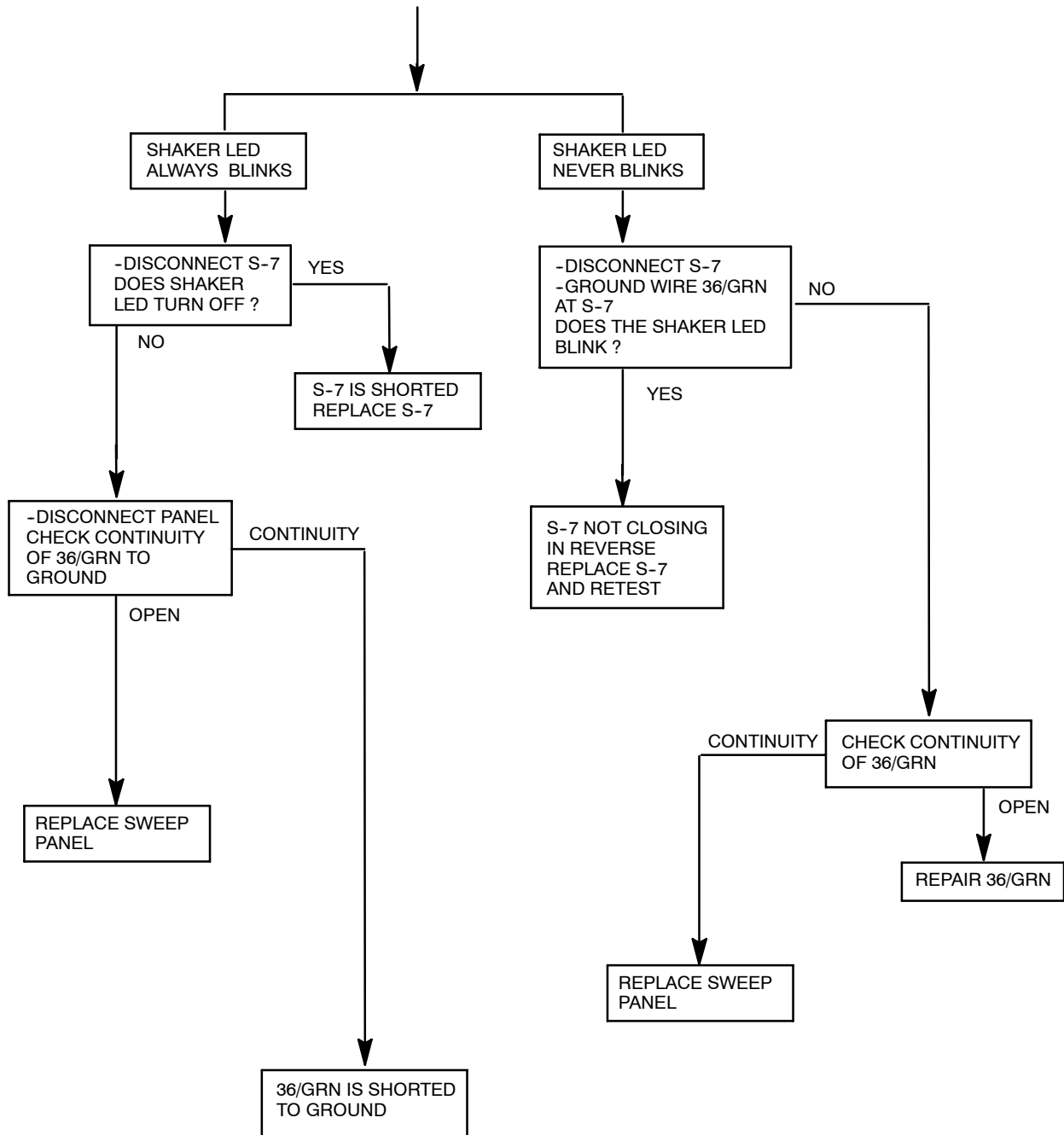

CONTENTS

| | Page | | Page |
|---------------------------------|------|------------------------------|------|
| INTRODUCTION | 6-3 | TROUBLESHOOTING | 6-61 |
| HYDRAULIC FLUID RESERVOIR | 6-4 | 8410 HYDRAULIC PUMP | |
| HYDRAULIC FLUID | 6-5 | OPERATION | 6-62 |
| HYDRAULIC HOSES | 6-5 | 8410 HYDRAULIC PUMP LOW | |
| TO REPLACE DIRECTIONAL PEDAL | | PRESSURE FLOW | 6-63 |
| CENTERING SPRING | 6-6 | 8410 HYDRAULIC PUMP INCREASE | |
| TO REPLACE DIRECTIONAL | | FLOW DEMAND | 6-64 |
| CONTROL CABLE | 6-8 | 8410 HYDRAULIC PUMP HIGH | |
| TO ADJUST DIRECTIONAL | | PRESSURE | 6-65 |
| CONTROL | 6-11 | ENGINE FAN CIRCUIT | |
| TO REPLACE PROPEL PUMP | 6-12 | (HIGH SPEED) | 6-66 |
| TO REPLACE LOAD SENSING | | ENGINE FAN CIRCUIT | |
| PUMP | 6-15 | (IDLE SPEED) | 6-67 |
| TO REPLACE HYDRAULIC | | ENGINE FAN DOES NOT RUN | 6-68 |
| STEERING VALVE | 6-18 | ENGINE FAN ALWAYS RUNS FAST | 6-69 |
| TO REPLACE MAIN HYDRAULIC | | ENGINE FAN ALWAYS RUNS SLOW | 6-70 |
| VALVE | 6-19 | SCRUB FAN CIRCUIT | 6-72 |
| TO REPLACE SCRUB VALVE | 6-21 | SCRUB FAN DOES NOT TURN OFF | 6-73 |
| TO REPLACE SOLENOID VALVE | | SCRUB FAN DOES NOT TURN ON | 6-74 |
| CARTRIDGE | 6-23 | HOPPER DOOR CLOSE CIRCUIT . | 6-76 |
| TO REPLACE REAR DRIVE MOTOR | 6-24 | HOPPER DOOR DOES NOT OPEN | 6-77 |
| TO REPLACE SWEEPING VACUUM | | HOPPER DOOR DOES NOT CLOSE | 6-78 |
| FAN HYDRAULIC MOTOR | 6-26 | HOPPER DOOR DOES NOT | |
| TO REPLACE ENGINE COOLING | | STAY CLOSED | 6-79 |
| FAN HYDRAULIC MOTOR | 6-28 | HOPPER LIFT CIRCUIT | 6-80 |
| TO REPLACE SCRUB VACUUM | | HOPPER DOES NOT RAISE | 6-81 |
| FAN HYDRAULIC MOTOR | 6-30 | HOPPER DRIFTS DOWN | |
| TO REPLACE SCRUB BRUSH | | TOO QUICKLY | 6-82 |
| HYDRAULIC MOTOR | 6-32 | HOPPER LOWER CIRCUIT | 6-84 |
| TO REPLACE MAIN BRUSH | | HOPPER DOES NOT LOWER | 6-85 |
| HYDRAULIC MOTOR | 6-34 | MAIN BRUSH CIRCUIT - SPD 1 | |
| TO REPLACE SIDE BRUSH MOTOR | 6-36 | (MAIN BRUSH DOWN AND ON, | |
| TO REPLACE STEERING | | VAC FAN ON) | 6-86 |
| CYLINDER | 6-38 | MAIN BRUSH CIRCUIT - SPD 2 | |
| TO REPLACE HOPPER LIFT | | (MAIN BRUSH DOWN AND ON, | |
| CYLINDER | 6-41 | VAC FAN ON) | 6-87 |
| TO REPLACE HOPPER DUMP | | MAIN BRUSH DOES NOT RAISE .. | 6-88 |
| DOOR CYLINDER | 6-42 | MAIN BRUSH DOES NOT LOWER . | 6-89 |
| TO REPLACE MAIN BRUSH LIFT | | MAIN BRUSH DOES NOT | |
| CYLINDER | 6-43 | TURN OFF | 6-90 |
| TO REPLACE SIDE BRUSH LIFT | | MAIN BRUSH DOES NOT TURN ON | 6-91 |
| CYLINDER | 6-45 | SWEEPER FAN DOES NOT | |
| TO REPLACE SQUEEGEE LIFT | | TURN OFF | 6-92 |
| CYLINDER | 6-46 | SWEEPER FAN DOES NOT | |
| TO REPLACE SCRUB BRUSH LIFT | | TURN ON | 6-93 |
| CYLINDER | 6-48 | SIDE BRUSH CIRCUIT - SPD 1 | |
| TO REPLACE SCRUB HEAD SIDE | | (MAIN BRUSH ON, VAC FAN ON, | |
| SHIFT HYDRAULIC CYLINDER . | 6-50 | SIDE BRUSH DOWN AND | |
| HYDRAULIC SCHEMATIC | 6-52 | ON) | 6-94 |
| HYDRAULIC HOSE GROUP | 6-56 | SIDE BRUSH CIRCUIT - SPD 2 | |
| CLAMP LOCATION AND HOSE | | (MAIN BRUSH ON, VAC FAN ON, | |
| ORIENTATION | 6-58 | SIDE BRUSH DOWN AND | |
| | | ON) | 6-95 |

| | Page |
|---|-------|
| SIDE BRUSH DOES NOT RAISE . . | 6-96 |
| SIDE BRUSH DOES NOT LOWER . | 6-97 |
| SIDE BRUSH DOES NOT TURN OFF | 6-98 |
| SIDE BRUSH DOES NOT TURN ON | 6-99 |
| EDGE SCRUB CIRCUIT | 6-100 |
| SCRUB HEAD DOES NOT GO IN . | 6-101 |
| SCRUB HEAD DOES NOT GO OUT | 6-102 |
| SCRUB HEAD LOWER CIRCUIT .. | 6-104 |
| SCRUB BRUSHES DO NOT LOWER | 6-105 |
| SCRUB HEAD RAISE CIRCUIT ... | 6-106 |
| SCRUB BRUSHES DO NOT RAISE | 6-107 |
| SCRUB BRUSH CIRCUIT | 6-108 |
| SCRUB BRUSHES DO NOT TURN OFF | 6-109 |
| SCRUB BRUSHES DO NOT TURN ON | 6-110 |
| SQUEEGEE LIFT CIRCUIT | 6-112 |
| SQUEEGEE DOES NOT RAISE . . | 6-113 |
| SQUEEGEE DRIFTS DOWN TOO QUICKLY | 6-114 |
| SQUEEGEE LOWER CIRCUIT ... | 6-116 |
| SQUEEGEE DOES NOT LOWER . | 6-117 |
| LEFT TURN CIRCUIT | 6-118 |
| RIGHT TURN CIRCUIT | 6-119 |

INTRODUCTION

The hydraulic system consists of the propel pump, accessory pump, control valve, drive motors, steering cylinder, and vacuum fan motor.

HYDRAULICS

HYDRAULIC FLUID RESERVOIR

The reservoir is located in the engine compartment next to the radiator.

Mounted on top of the reservoir is a filler cap with a built-in breather and fluid level dipstick. Replace the cap every 800 hours of operation.

Check the hydraulic fluid level at operating temperature every 100 hours of operation. Make sure the hopper is down when checking hydraulic fluid level. The end of the dipstick is marked with FULL and ADD levels to indicate the level of hydraulic fluid in the reservoir.

Lubricate the filler cap gasket with a film of hydraulic fluid before putting the cap back on the reservoir.

ATTENTION! Do not overfill the hydraulic fluid reservoir or operate the machine with a low level of hydraulic fluid in the reservoir. Damage to the machine hydraulic system may result.

Drain and refill the hydraulic fluid reservoir with new hydraulic fluid every 800 hours of operation.

The hydraulic fluid filter is located at the bottom of the engine compartment. Replace the filter element every 800 hours of operation.

The reservoir has a built-in strainer outlet that filters hydraulic fluid before it enters the system. Replace the strainer every 800 hours of operation.

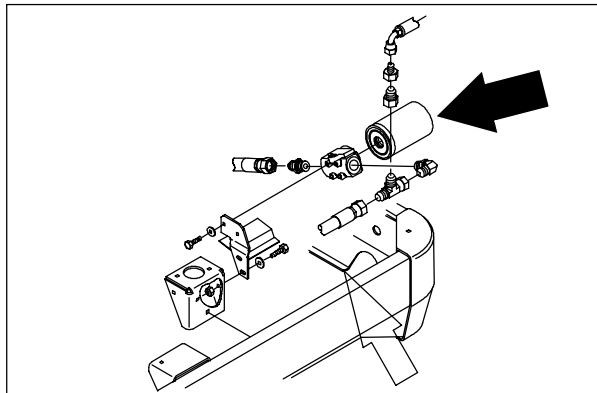
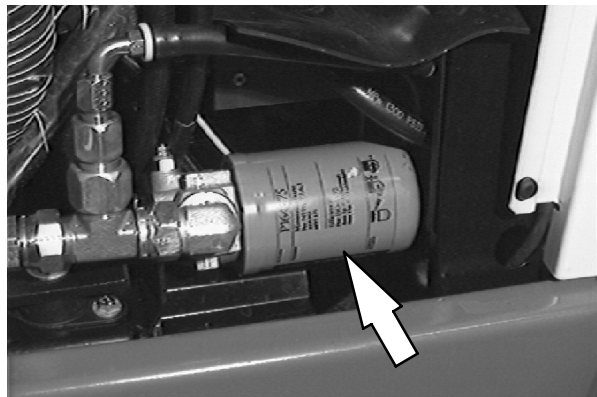
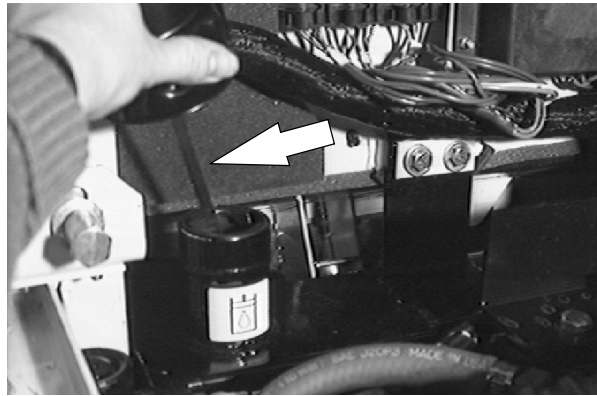

HYDRAULIC FLUID

The quality and condition of the hydraulic fluid play a very important role in how well the machine operates. Tennant's hydraulic fluid is specially selected to meet the needs of Tennant machines.

Tennant's hydraulic fluids provide a longer life for the hydraulic components. There are two fluids available for different temperature ranges:

| Tennant part no. | Ambient Temperature |
|------------------|---------------------|
| 65869 | above 7° C (45° F) |
| 65870 | below 7° C (45° F) |

The higher temperature fluid has a higher viscosity and should not be used at the lower temperatures. Damage to the hydraulic pumps may occur because of improper lubrication.

The lower temperature fluid is a thinner fluid for colder temperatures.

If a locally-available hydraulic fluid is used, make sure the specifications match Tennant hydraulic fluid specifications. Using substitute fluids can cause premature failure of hydraulic components.

European manufactured machines are filled with locally available hydraulic fluids. Check the label on the hydraulic fluid reservoir.

ATTENTION! Hydraulic components depend on system hydraulic fluid for internal lubrication. Malfunctions, accelerated wear, and damage will result if dirt or other contaminants enter the hydraulic system.

HYDRAULIC HOSES

Check the hydraulic hoses every 800 hours of operation for wear or damage.

Fluid escaping at high pressure from a very small hole can be almost invisible, and can cause serious injuries.

See a doctor at once if injury results from escaping hydraulic fluid. Serious infection or reaction can develop if proper medical treatment is not given immediately.

FOR SAFETY: When servicing machine, use cardboard to locate leaking hydraulic fluid under pressure.

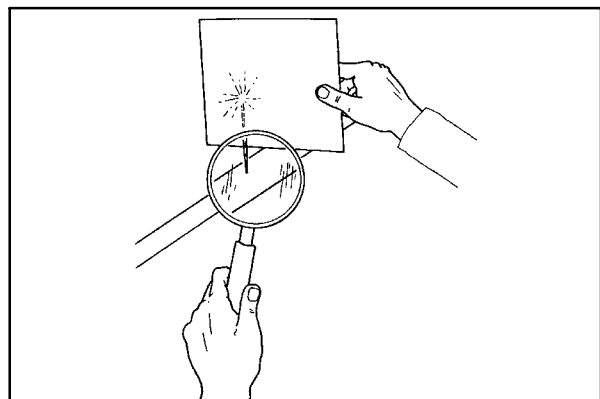

TO REPLACE DIRECTIONAL PEDAL CENTERING SPRING

1. Shut off the engine and engage the parking brake.

FOR SAFETY: Before Leaving Or Servicing Machine; Stop On Level Surface, Set Parking Brake, Turn Off Machine And Remove Key.

2. Remove the two M8 hex screws holding the rear radiator grill to the machine. Disconnect the taillight and remove the grill from the machine.
3. Remove the nyloc nut holding the centering spring balljoint to the directional control arm.
4. Loosen the large jam nut holding the directional cable to the propel bracket.
5. Remove the spring assembly from the propel bracket and place it outside the back of the machine.
6. Remove the ball joint and jam nuts.
7. Unscrew the directional spring assembly from the directional control cable.

NOTE: The directional cable will have to be held to keep it from turning.

8. Thread a new directional spring assembly all the way on the directional control cable. Leave 0.25 in of threads showing on the 0.62 in diameter threads.
9. Install two 0.25 in. jam nuts on the end of the directional cable. Tighten one to the housing and the other one to the balljoint, leaving 0.06 in. between them.
10. Use the large jam nut to lock directional spring assembly in place.

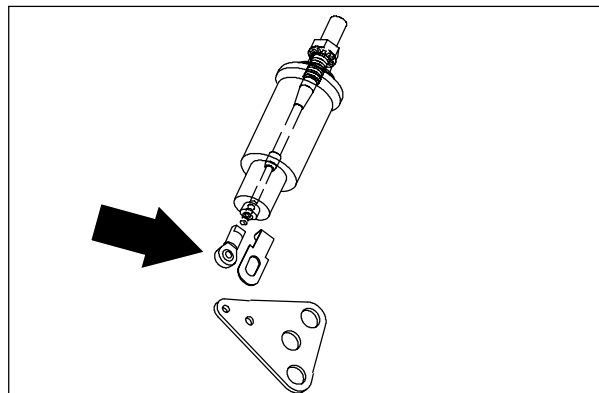
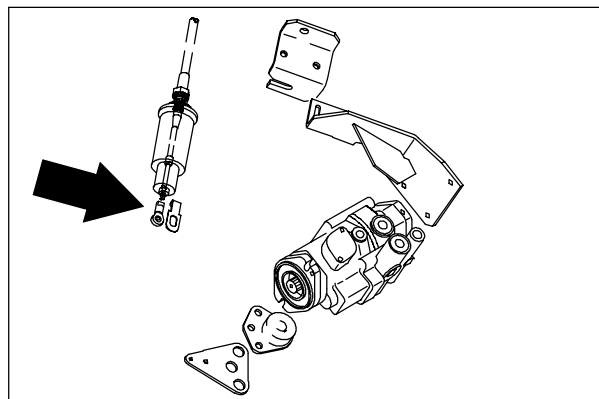
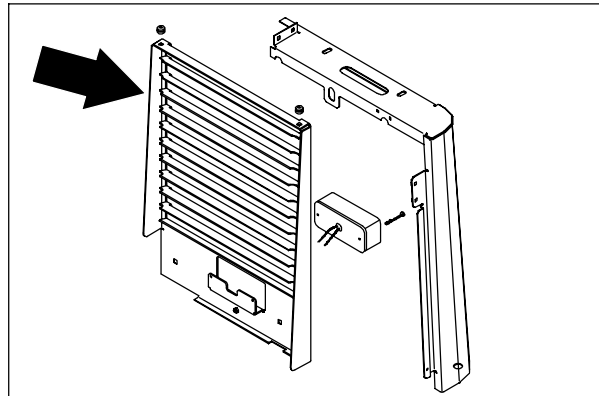
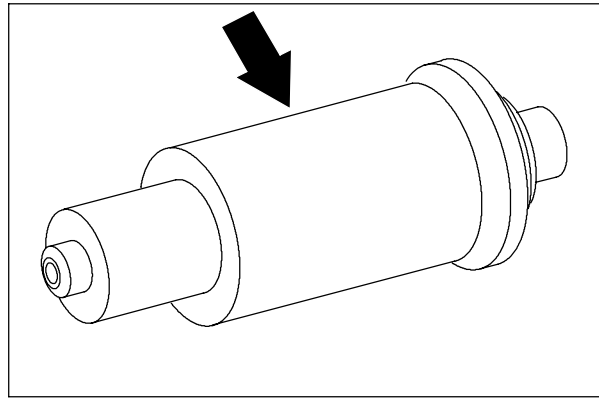

11. Reinstall the balljoint to the directional control arm. Tighten the 0.25 in. nyloc nut to 11 - 14 Nm (7 - 10 ft lb).
12. Jack up the rear of the machine.

FOR SAFETY: Block machine tires before jacking machine up. Jack machine up at designated locations only. Block machine up with jack stands.

13. Check the neutral centering of the propel pump by starting the machine and observing the rear tire for any rotation. If tire is rotating; See TO ADJUST DIRECTIONAL CONTROL instructions.
14. Once the neutral centering has been set; reinstall the rear grill panel. Tighten the four M8 hex screws to 18 - 24 Nm (15 - 20 ft lb). Lower the machine and test drive.

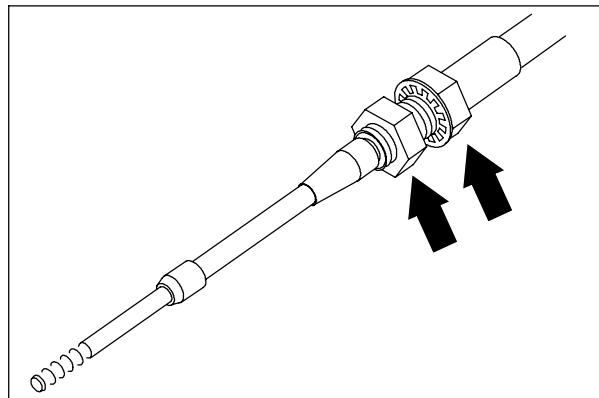
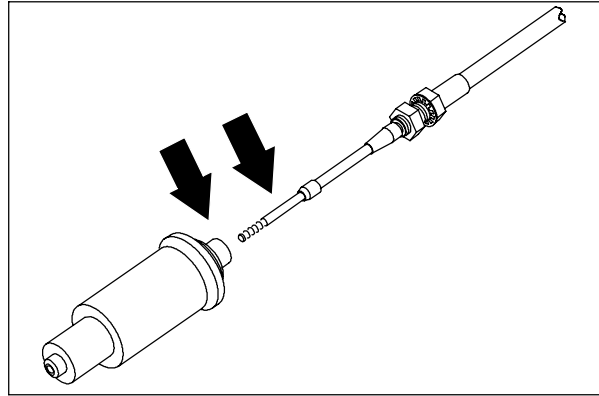

HYDRAULICS

TO REPLACE DIRECTIONAL CONTROL CABLE

1. Shut off the engine and engage the parking brake.

FOR SAFETY: Before Leaving Or Servicing Machine; Stop On Level Surface, Set Parking Brake, Turn Off Machine And Remove Key.

2. Lift the battery cover and disconnect the battery cables.
3. Remove the battery hold down bracket and remove the battery.
4. Remove the 0.25 nyloc nut holding the control cable balljoint to the directional pedal assembly.
5. Remove the cotter pin and clevis pin from the directional control pedal. Remove the pedal from the machine.
6. Loosen the two large hex nuts holding the control cable to the mount bracket on the floor plate.
7. Go under machine on operators side and locate the two M5 hex screws holding the clamp on the speed limiter cable. Remove screws and clamp.
8. Go under machine and remove any clamps or plastic ties holding control cable to the machine frame.

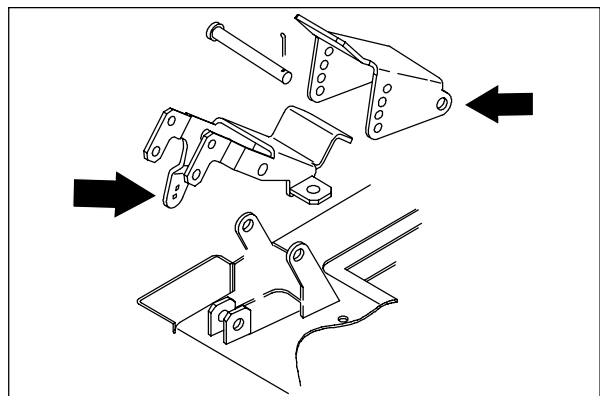
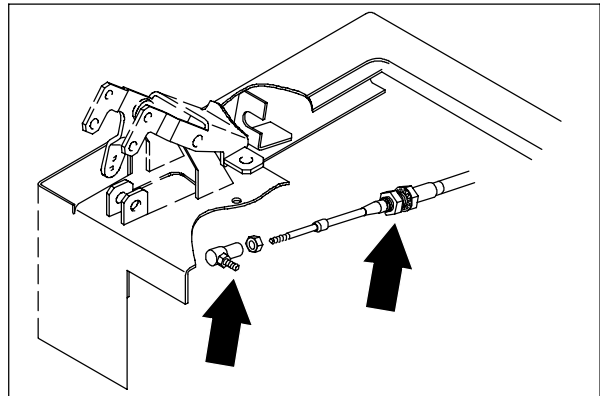
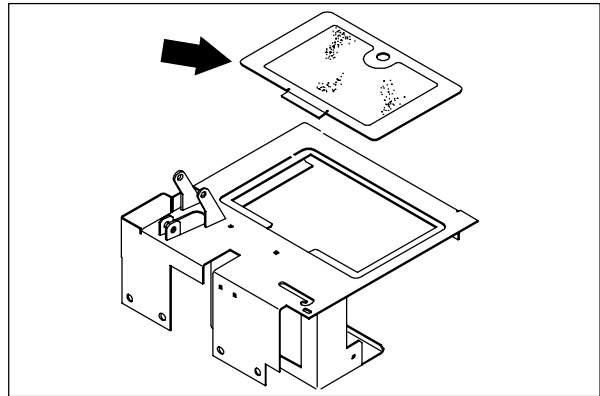
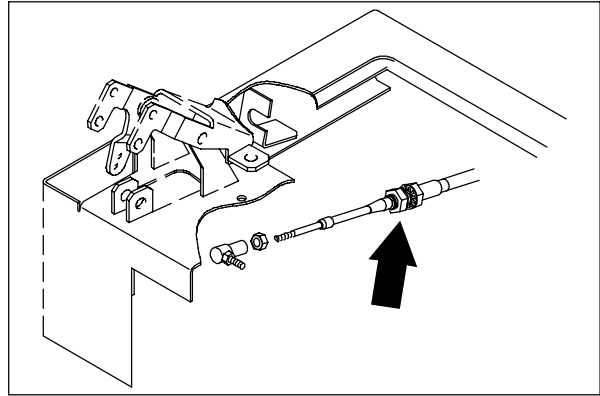

9. Remove the two hex screws holding the rear radiator grill to the machine. Unplug the taillight and remove the grill from the machine.
10. Remove the 0.25 in. nyloc nut holding the centering spring balljoint to the directional control arm on the propel pump.
11. Loosen the large jam nuts holding the directional cable to mount bracket on the propel pump.
12. Remove the cable from the bracket and position it outside the back of the machine.
13. Unscrew the directional spring assembly from the directional control cable.

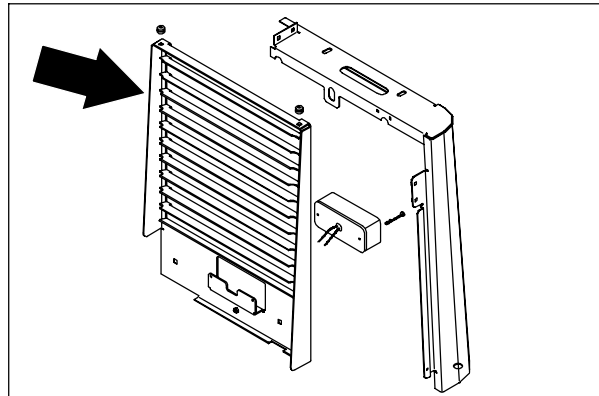

NOTE: Control cable will have to be held to keep it from turning.

14. The old control cable can now be removed from the machine and a new one installed. Remove one of the jam nuts and thread the other one all the way on.

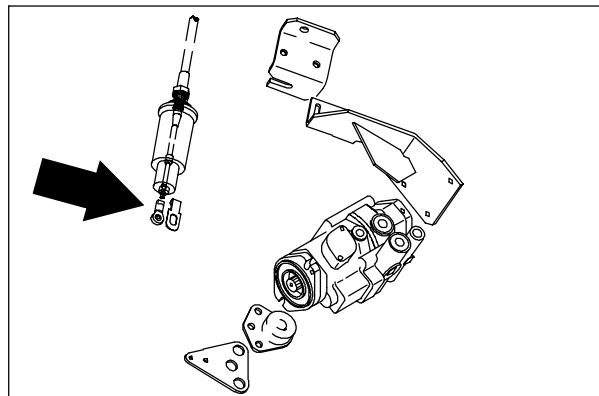

NOTE: The end of the cable with 1.5 in of thread goes to the directional spring.

15. Make sure to route the cable between the square tube of the frame and the scrub head.
16. Thread the directional spring assembly all the way back on the directional control cable. Leave 0.25 in of threads showing on the 0.62 in diameter threads.

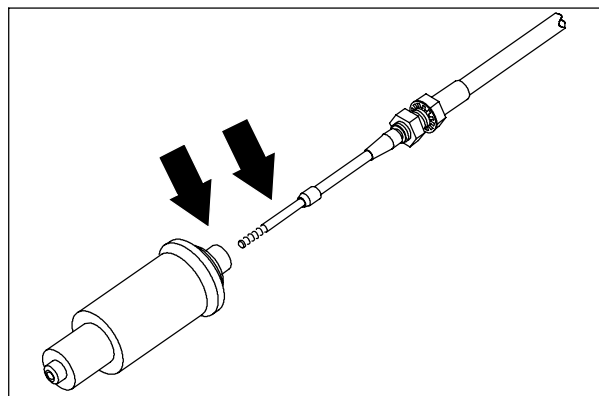
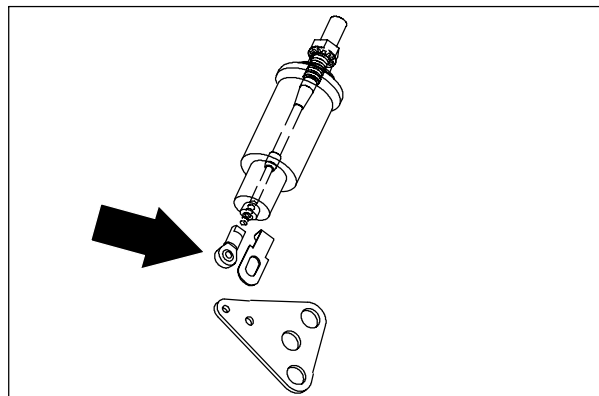

HYDRAULICS

17. Install two 0.25 in. jam nuts on the end of the cable. Tighten one to the housing and the other one to the balljoint, leaving 0.06 (1/16 in.) between them.
18. Reconnect the balljoint to the propel pump control arm using the 0.25 nyloc nut. Tighten to 11 - 14 Nm (7 - 10 ft lb).
19. Position the control cable back in the cable mount bracket on the propel pump. Firmly hand tighten large jam nut.
20. Install the control cable back in the mount bracket on the bottom of the floor plate. Firmly hand tighten large jam nuts so there is an equal amount of threads showing on both sides of bracket.
21. Reinstall the foot pedal with the clevis pin and cotter pin.
22. Reinstall the 0.25 in. jam nut and balljoint on the pedal end of control cable. Adjust it so there is 1.5 in. of movement between jam nut and rubber seal.
23. Reconnect the directional control cable balljoint to foot pedal with 0.25 nyloc nut. Tighten to 11 - 14 Nm (7 - 10 ft lb).
24. Jack up the rear of the machine.

FOR SAFETY: Block machine tires before jacking machine up. Jack machine up at designated locations only. Block machine up with jack stands.

25. Check the neutral centering of the propel pump by starting the machine and observing the rear tire for any sign of rotation. If the tire is rotating See TO ADJUST DIRECTIONAL CONTROL instructions.
26. Once the neutral centering has been set, reinstall the rear grill panel. Tighten the four M8 hex screws to 18 - 24 Nm (15 - 20 ft lb). Lower the machine.

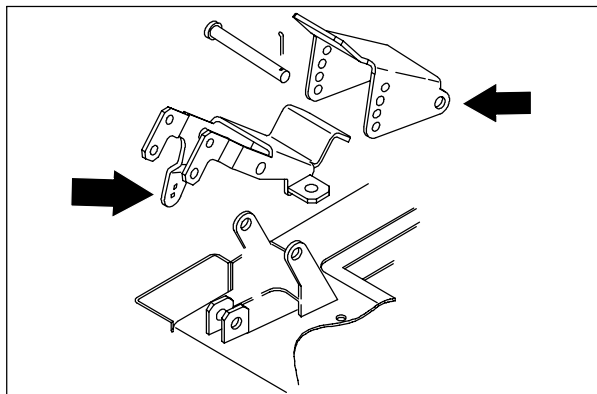
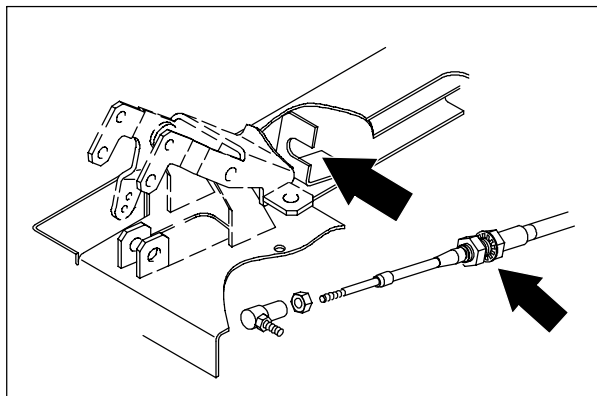
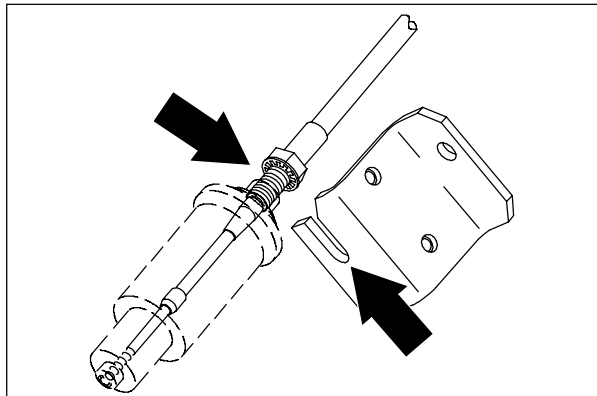
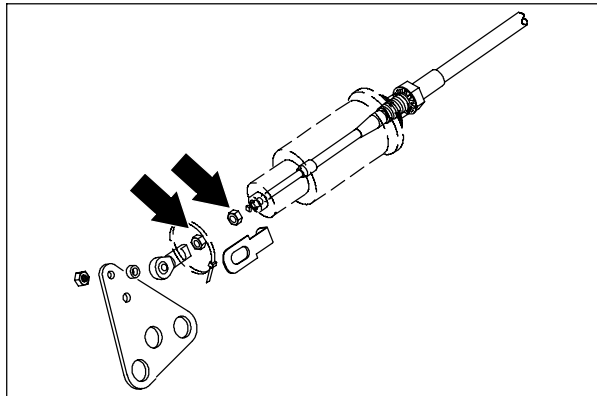

TO ADJUST DIRECTIONAL CONTROL

1. Set the emergency brake and start the engine.

FOR SAFETY: Before Leaving Or Servicing Machine; Stop On Level Surface, Set Parking Brake, Turn Off Machine And Remove Key.

2. Jack up the rear of machine.

FOR SAFETY: Block machine tires before jacking machine up. Jack machine up at designated locations only. Block machine up with jack stands.

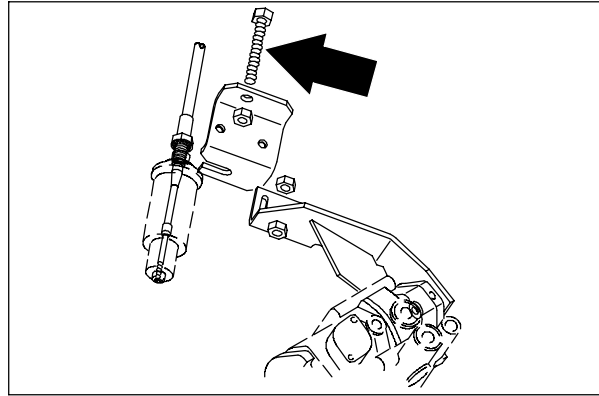

3. Check the neutral centering of the pump by observing the rear tire for any rotation.
4. If the rear tire is rotating, shut off the engine and go under the machine by the engine muffler.
5. Look up at the propel pump and locate the long threaded adjustment bolt on the movable cable bracket. Loosen the jam nuts.

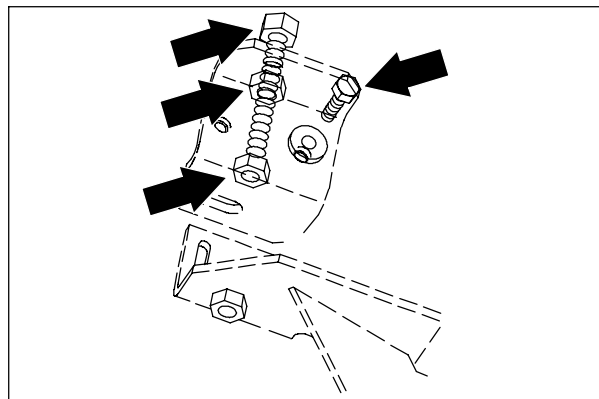

6. Loosen the two hex screws holding the movable cable bracket to the fixed pump bracket.
7. Start the machine and observe the rear tire for any rotation. If the tire is rotating in either direction, turn the long threaded adjustment bolt until the rotation stops. Tighten the jam nuts and hex screws.
8. For fine adjustments the balljoint on the end of the propel cable can be rotated in or out a few turns.

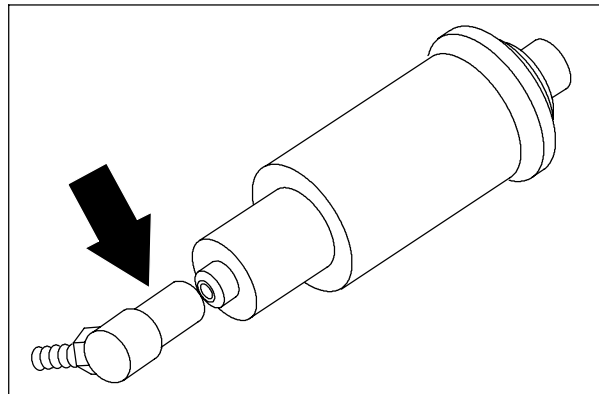

9. Lower the machine to the ground and operate. Check to see if the machine creeps in either direction.

TO REPLACE PROPEL PUMP

1. Start the engine and lower the squeegee.

FOR SAFETY: Before Leaving Or Servicing Machine; Stop On Level Surface, Set Parking Brake, Turn Off Machine And Remove Key.

2. Disconnect the battery cables from the battery.
3. Jack up the rear of the machine.

FOR SAFETY: Block machine tires before jacking machine up. Jack machine up at designated locations only. Block machine up with jack stands.

4. Remove two M8 hex screws holding the rear radiator grill to the machine. Unplug the taillight and remove the grill from the machine.
5. Open the engine cover and side door.
6. Remove the muffler and exhaust pipe.
7. Remove hex screws holding directional control cable mount bracket to the back of propel pump.
8. Remove the hex screw holding the propel pump arm to the pump hub.
9. Unplug the pump switch from main harness.
10. Move the pump arm, cable mount bracket, and control cable back out of the way.
11. Remove and plug the four hydraulic hoses leading to the propel pump.

NOTE: Observe hydraulic cleanliness requirements when opening hydraulic lines.

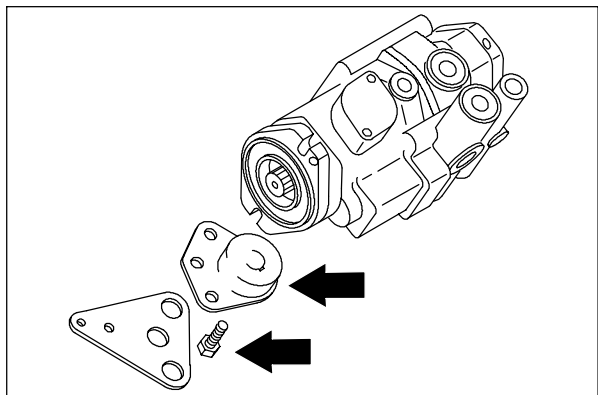
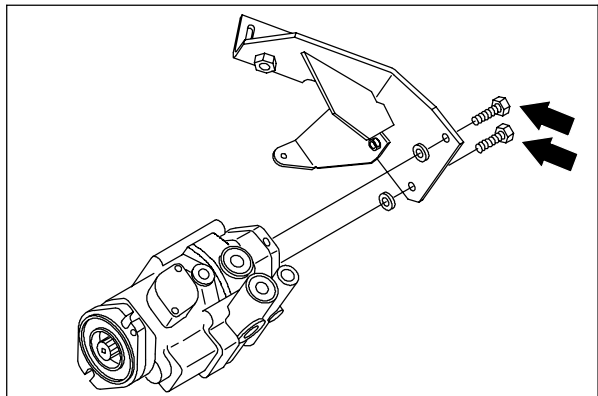
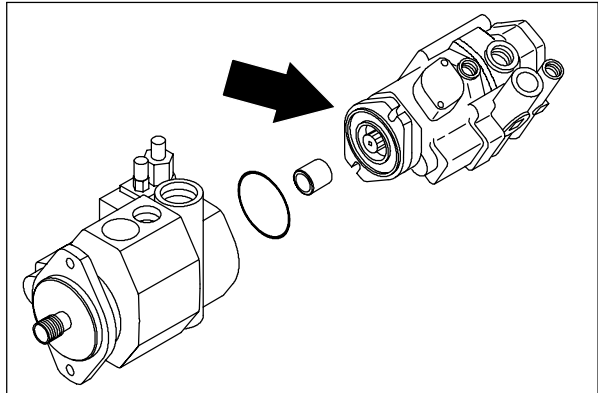
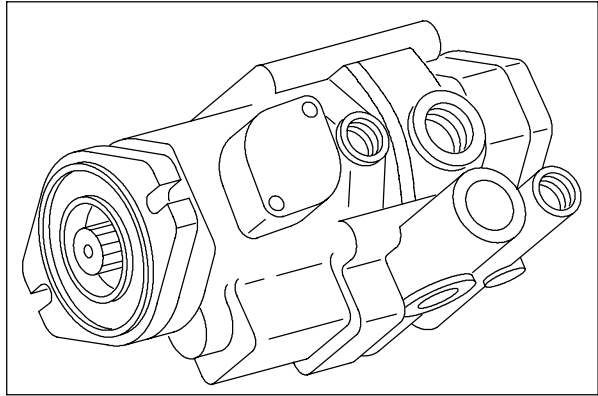

12. Remove the two 0.38 in. hex screws holding the propel pump to the load sensing pump.
13. Move the flow switch and mounting bracket out of the way.
14. The propel pump can now be pulled back and out of the load sensing pump.

NOTE: Be careful not to loose or damage the o-ring or the pump coupler.

15. Remove the propel pump from the machine.
16. Remove the hydraulic fittings from the old pump and install them in the new one. Make sure the fittings are installed in the same orientation as they were removed.
17. Remove hub from the pump shaft on the old propel pump. A puller may needed to break the hub loose.

18. Install the hub on the new pump shaft. Use the new key already on the pump shaft. Lightly tap the hub on the taper shaft with a hammer so it will stay in place until the hardware is installed.

19. Position pump back in the machine. Make sure the o-ring and coupler are in place. Reinstall the 0.38 in. hex screws with blue loctite 242. Place the flow switch bracket under the bolt heads. Tighten to 31 - 40 Nm (27 - 35 ft lb).

NOTE: Be careful not to loose or damage the o-ring or the pump coupler.

20. Reconnect the hydraulic hoses. See the schematic in this section.

NOTE: Observe hydraulic cleanliness requirements when opening hydraulic lines.

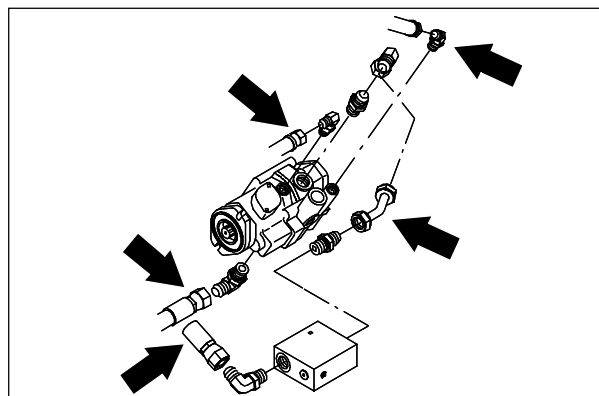
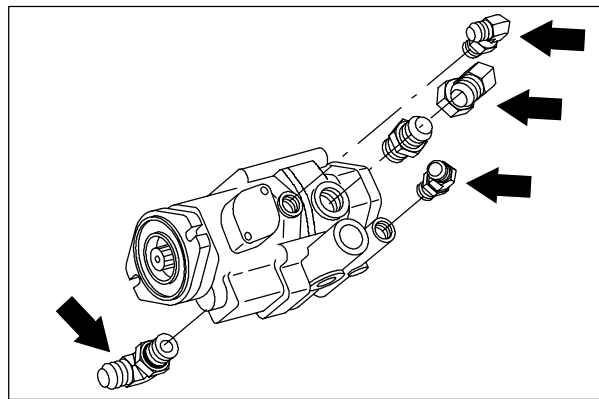
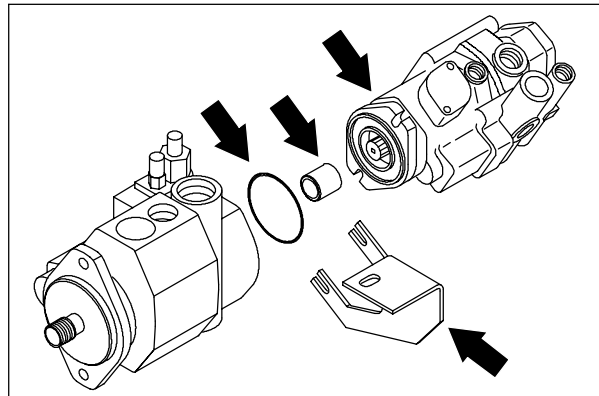
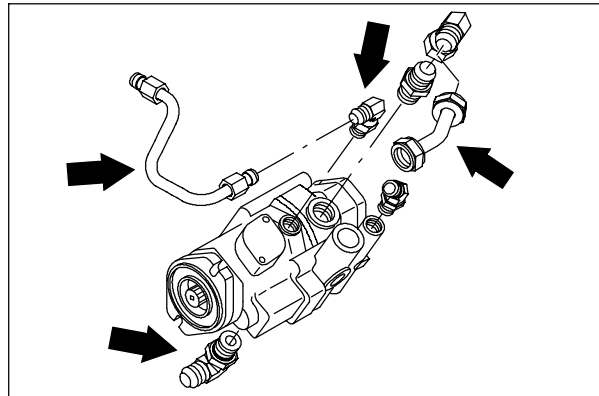

HYDRAULICS

21. Place the control cable, cable mount plate, and the pump arm back in position.
22. Align the mount holes in the cable plate with the holes in the back of the propel pump. Reinstall the 0.38 in. hex screws and washers. Make sure to put one washer between the plate and pump under each hex screw. Use blue loctite 242 and tighten to 31 - 40 Nm (27 - 35 ft lb).
23. Reinstall the pump arm to the pump hub using the two M8 hex screws on the outside and one 0.31 in. hex screw in the center. Tighten to 18 - 24 Nm (15 - 20 ft lb).
24. Reconnect the pump switch to the main electrical harness.
25. Reinstall the muffler and exhaust pipe.
26. Reconnect the battery cables.
27. Check the neutral centering of the new propel pump by starting the machine and observing the rear tire for any rotation. If tire is rotating See TO ADJUST DIRECTIONAL CONTROL instructions in this section.
28. Once the neutral centering has been set, reinstall rear grill panel. Tighten four M8 hex screws to 18 - 24 Nm (15 - 20 ft lb). Lower the machine.

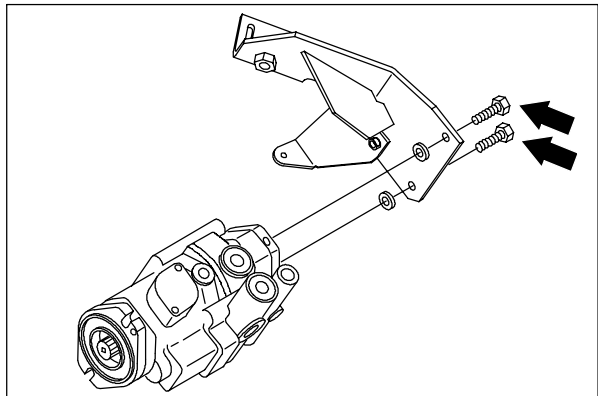
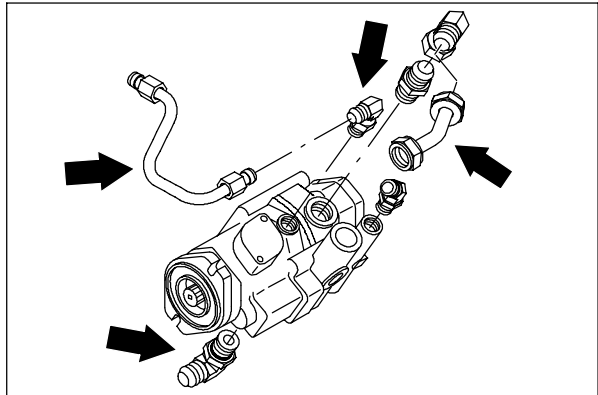
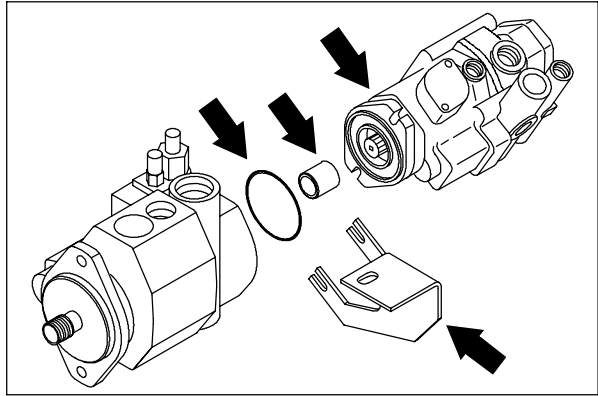

TO REPLACE LOAD SENSING PUMP

1. Start the engine and lower the squeegee.

FOR SAFETY: Before Leaving Or Servicing Machine; Stop On Level Surface, Set Parking Brake., Turn Off Machine And Remove Key.

2. Jack up the rear of the machine.

FOR SAFETY: Block machine tires before jacking machine up. Jack machine up at designated locations only. Block machine up with jack stands.

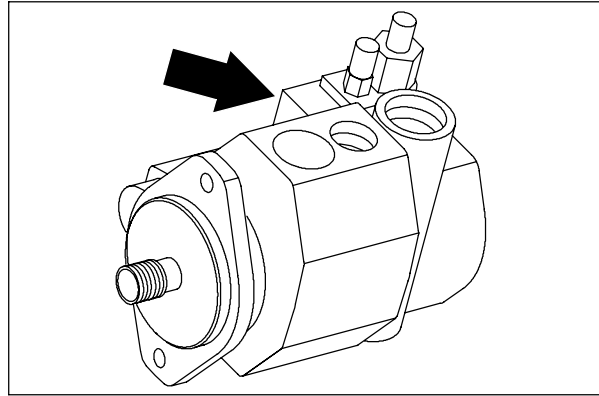

3. Open the engine cover and side door.
4. Lift the engine side door off the hinges and put it aside.
5. Remove two M8 hex screws holding the rear radiator grill to the machine. Unplug the taillight and remove the grill from the machine.
6. Remove the muffler and exhaust pipe.
7. Drain the hydraulic tank.

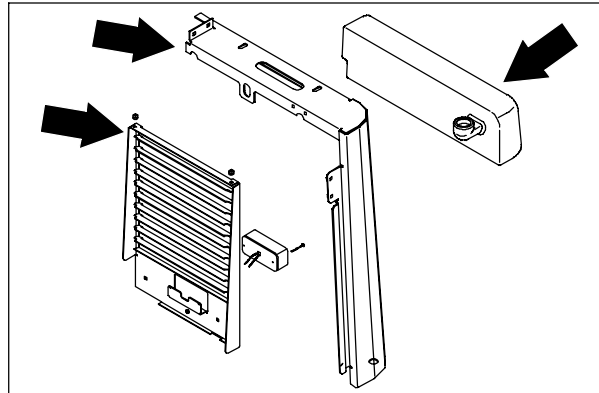

8. Remove the radiator overflow tank.
9. Remove the left hand corner channel.
10. Drain the radiator and disconnect the radiator hoses from the radiator.
11. Remove and plug hydraulic hoses going to the hydraulic oil cooler that sits behind engine radiator.
12. Remove and plug the hydraulic hoses going to the engine cooling fan hydraulic motor.

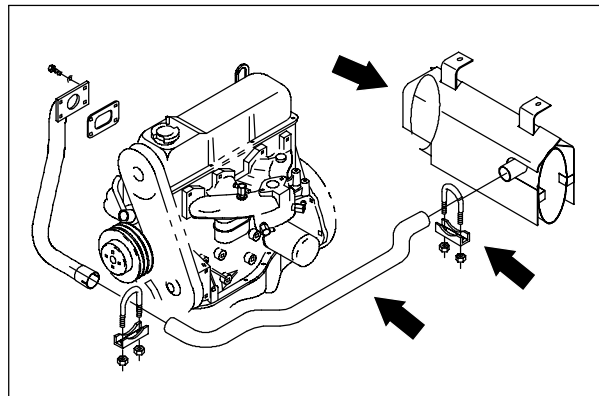

NOTE: Observe hydraulic cleanliness requirements when opening hydraulic lines.

13. Remove the two nyloc nuts holding the bottom of the radiator to the mounting channel.
14. The radiator assembly can now be carefully lifted out and set aside.
15. Remove the six M8 hex screws holding the mounting channel to the frame. Remove the channel.

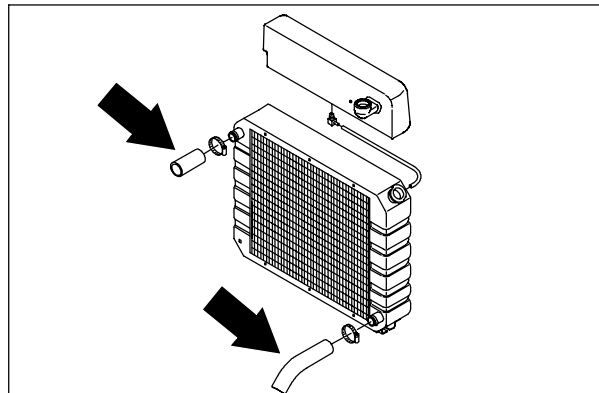

HYDRAULICS

16. Remove the hex screws holding the propel pump to the load sensing pump.
17. Move the flow switch and mounting bracket out of the way.
18. The propel pump can now be pulled back out of the load sensing pump.

NOTE: Be careful not to loose or damage the o-ring or the pump coupler.

19. Remove and plug the hydraulic hoses going to the load sensing pump.

NOTE: Observe hydraulic cleanliness requirements when opening hydraulic lines.

20. Remove the two M12 hex screws holding the load sensing pump to the bellhousing.
21. The load sensing pump can now be pulled back out of the flywheel coupler and removed from the machine.
22. Remove the fittings from the old pump and install in the new pump in the same orientation they were removed.
23. Place a small amount of grease on the splines of the new pump and install it back in the machine.
24. Align the holes in pump flange with holes in bellhousing. Install the two M12 hex screws with blue loctite 242 and tighten to 31 - 40 Nm (27 - 35 ft lb).
25. Reconnect the hydraulic hoses to the load sensing pump. See the schematic in this section.
26. Position the propel pump back in the load sensing pump. Make sure o-ring and coupler are in place. Reinstall the 0.38 in. hex screws with blue loctite 242. Place the flow switch bracket back under the bolt heads. Tighten to 31 - 40 Nm (27 - 35 ft lb).
27. Reinstall the radiator mounting channel using six M8 hex screws. Tighten to 18 - 24 Nm (15 - 20 ft lb).

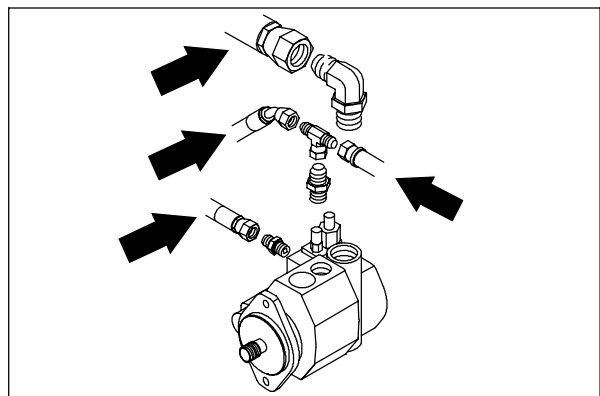
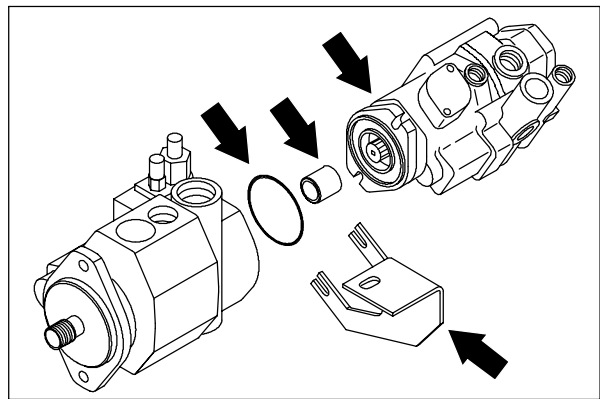
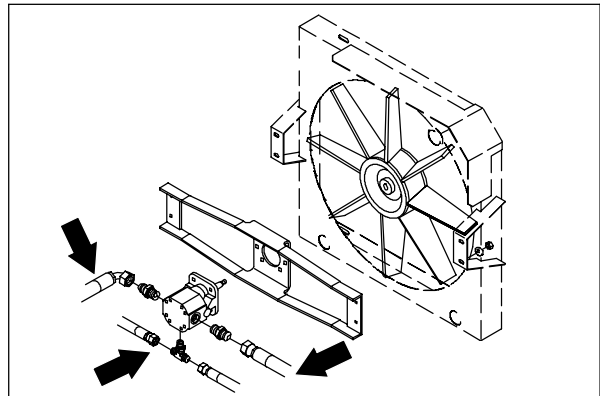
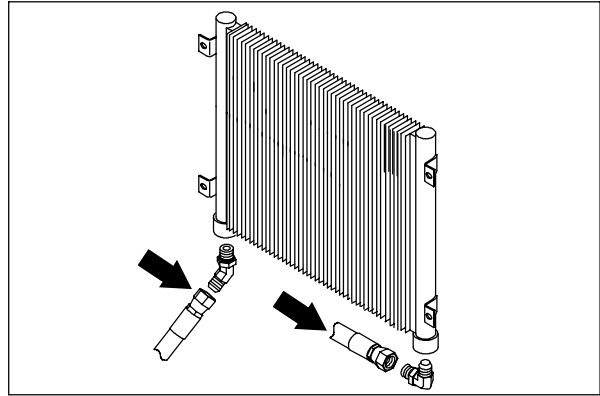

28. Place the radiator assembly back on the mount channel. Reinstall the two M10 nyloc nuts and washers and tighten to 18 - 24 Nm (15 - 20 ft lb).
29. Reconnect the hydraulic hoses to the engine cooling fan motor. See the schematic in this section.
30. Reconnect the hydraulic hoses to the hydraulic oil cooler. See the schematic in this section.
31. Reconnect the radiator hoses to the radiator.
32. Position the LH tower back on the machine.
33. Tighten the M8 hex screws to 18 - 24 Nm (15 - 20 ft lb). Tighten the M10 hex screw to 52 - 67 Nm (39 - 51 ft lb).
34. Reinstall the muffler and exhaust pipe.
35. Refill the engine radiator with coolant.
36. Refill the hydraulic fluid reservoir with the proper grade of hydraulic fluid.
37. Reinstall the engine side door.
38. Start the engine and check for proper operation and leaks.
39. Once the neutral centering has been set, reinstall rear grill panel. Tighten four M8 hex screws to 18 - 24 Nm (15 - 20 ft lb). Lower the machine.

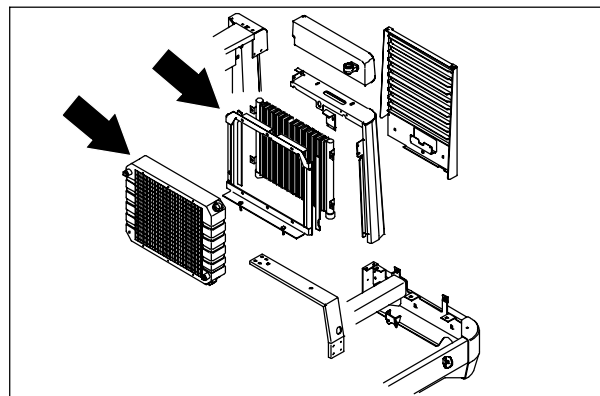
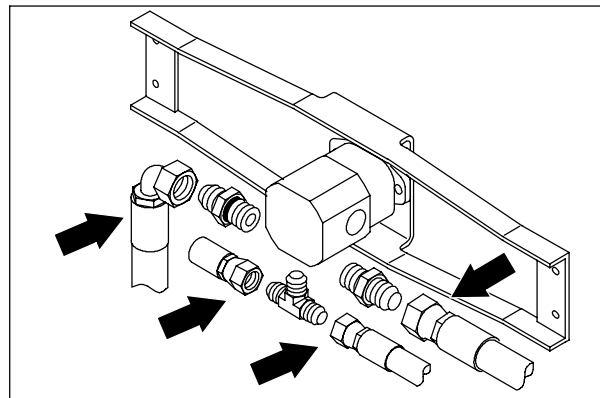
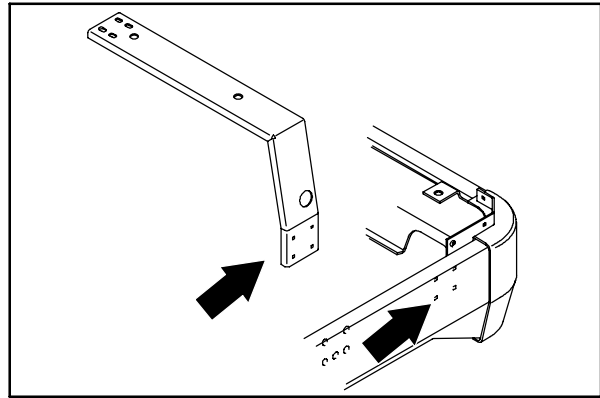

HYDRAULICS

TO REPLACE HYDRAULIC STEERING VALVE

1. Turn off the engine and engage the parking brake.

FOR SAFETY: Before Leaving Or Servicing Machine; Stop On Level Surface, Set Parking Brake, Turn Off Machine And Remove Key.

2. Remove the battery cables from the battery.
3. Remove the recovery tank. See TO REMOVE RECOVERY TANK instructions in the SCRUBBING section.
4. Remove and plug the five hydraulic hoses leading to the steering control motor.

NOTE: Observe hydraulic cleanliness requirements when opening hydraulic lines.

5. Remove the four M6 hex screws holding the hydraulic steering valve to the steering column.
6. The hydraulic steering valve can now be removed from machine.
7. Remove the hydraulic fittings from the old control motor. Install in the new or rebuilt control motor in the same orientation as they were removed.

NOTE: Remember to orientate the fittings as close as possible to the way they came out.

8. Install the new hydraulic steering valve assembly back in the machine. Position the ports in the same orientation as it was removed. Reinstall the four M6 hex screws and tighten to 8 - 10 Nm (5 - 7 ft lb).
9. Reconnect the five hydraulic hoses to the hydraulic steering valve. See the schematic in this section.
10. Reconnect battery cables. Start engine and move the steering wheel back and forth, checking for leaks and proper operation.
11. Reinstall the recovery tank. See TO INSTALL RECOVERY TANK instructions in the SCRUBBING section.

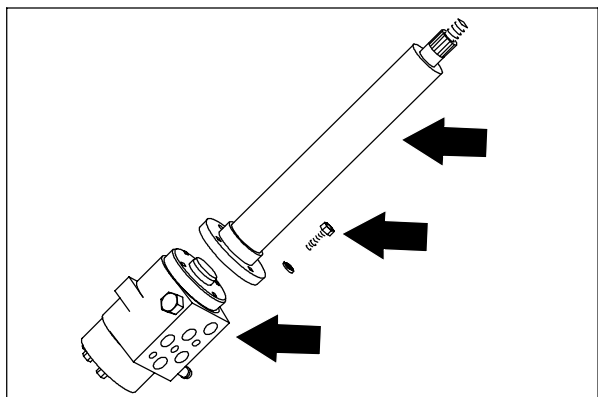
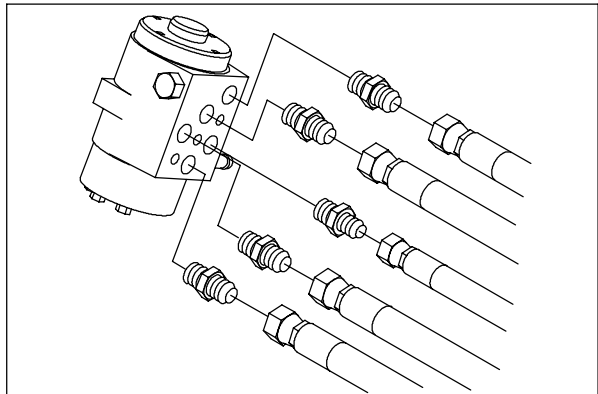
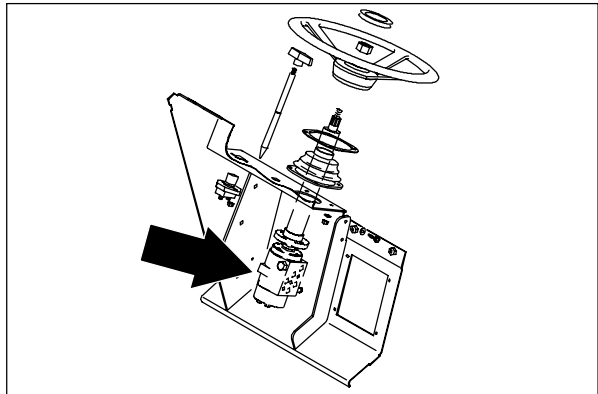
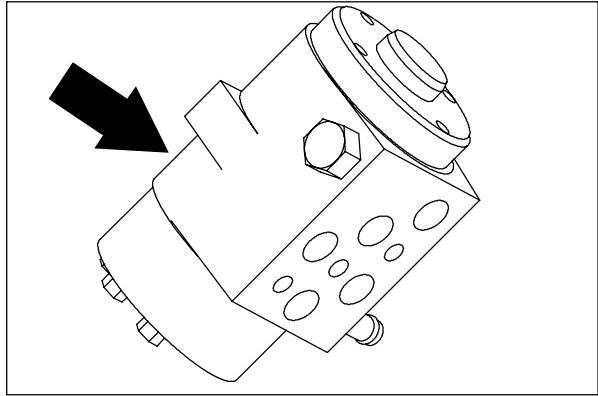

TO REPLACE MAIN HYDRAULIC VALVE

NOTE: Do Not replace complete valve unless the manifold block has cracked, otherwise replace individual component cartridge.

FOR SAFETY: Before Leaving Or Servicing Machine; Stop On Level Surface, Set Parking Brake., Turn Off Machine And Remove Key.

1. Jack up the rear of the machine.

FOR SAFETY: Block machine tires before jacking machine up. Jack machine up at designated locations only. Block machine up with jack stands.

2. Remove the battery cables from the battery.
3. Go under the machine on left side and locate the main hydraulic valve. Disconnect the electrical solenoids from the main harness.
4. Remove and cap the hydraulic hoses on the main hydraulic valve. Start with the hoses nearest the outside of the machine and work toward the center.

NOTE: Observe hydraulic cleanliness requirements when opening hydraulic lines.

5. Remove the three M8 hex screws holding the main valve to the mount bracket.
6. The main valve can now be dropped down and out of the machine.
7. Carefully place the valve in a vice. Note the orientation of fittings.

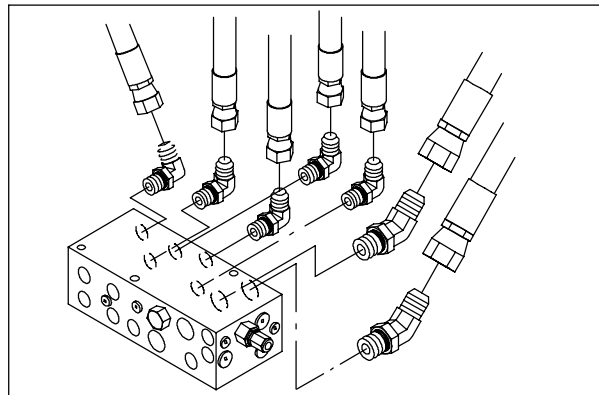
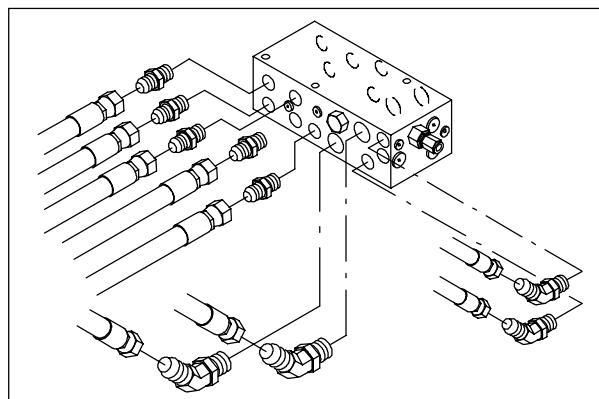
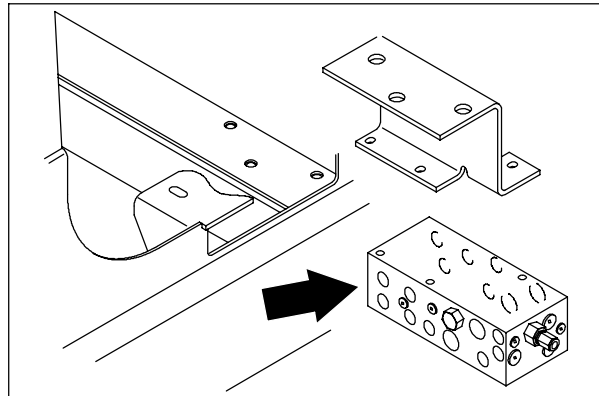

HYDRAULICS

8. Remove the hydraulic fittings from old valve and install in the new valve in the same orientation.

NOTE: Install the fittings in the new valve in the same orientation as they were removed.

9. Position the new valve back under machine. Reinstall the three M8 hex screws and washers. Tighten to 18 - 24 Nm (15 - 20 ft lb).
10. Reconnect the hydraulic hoses to the new valve. See the hydraulic schematic in this section. Start from the side of the valve nearest the center of the machine and work toward the outside.
11. Reconnect the electric solenoids to the main harness. See the schematic in the ELECTRICAL section of this manual.
12. Reinstall the brush guard using the two M12 hex screws. Tighten to 64 - 83 Nm (50 - 60 ft lb).
13. Remove the jack stands and lower the machine.
14. Reconnect the battery cables to the battery.
15. Start the machine and check the hydraulic components for proper operation.

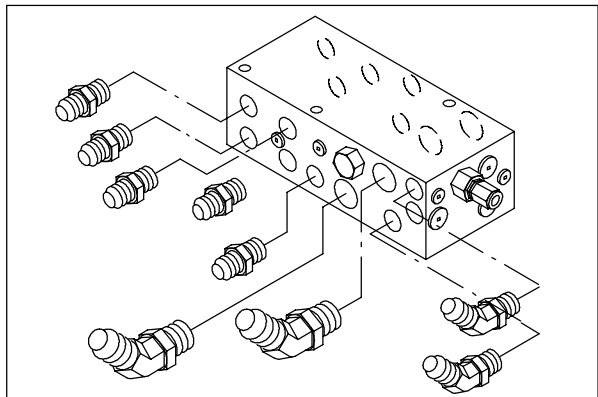
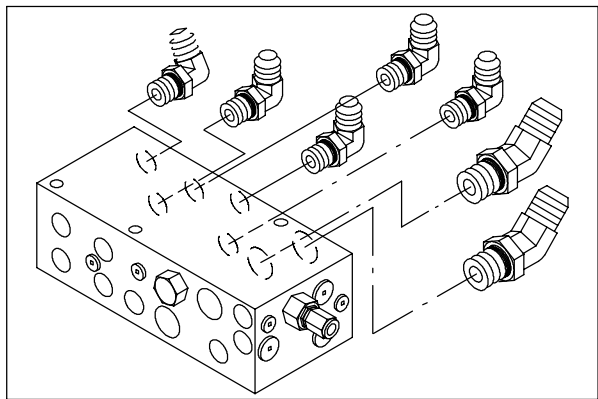
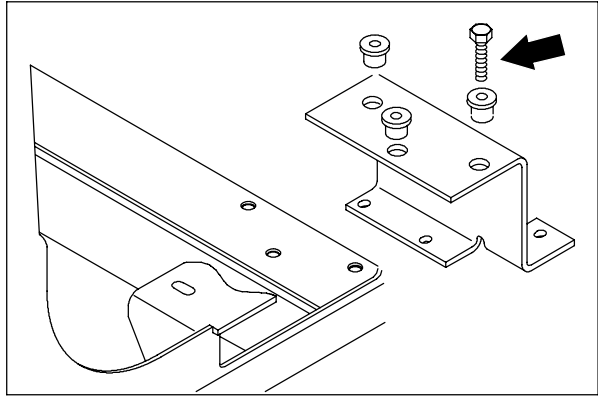

TO REPLACE SCRUB VALVE

NOTE: Do Not replace complete valve unless the manifold block has cracked, otherwise replace individual component cartridge.

FOR SAFETY: Before Leaving Or Servicing Machine; Stop On Level Surface, Set Parking Brake., Turn Off Machine And Remove Key.

1. The solution and recovery tanks must be removed in order to service the scrubber valve. See TO REMOVE SOLUTION TANK instructions in the SCRUBBING section of this manual.
2. Remove the battery cables from the battery.
3. Remove the main brush from the machine.
4. Locate the scrub valve on top of the machine frame near the front left tower.
5. Disconnect the electrical solenoids from main harness.
6. Remove and cap the hydraulic hoses on the scrub valve.

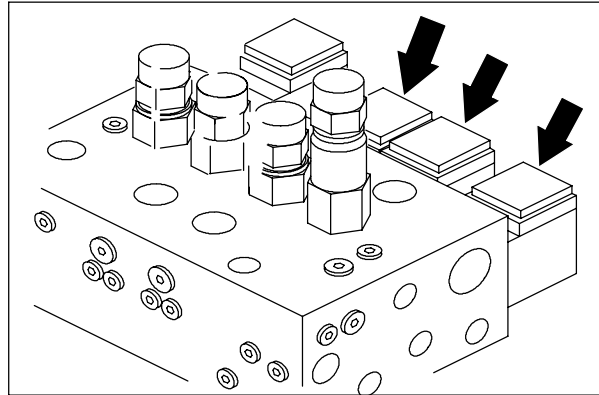
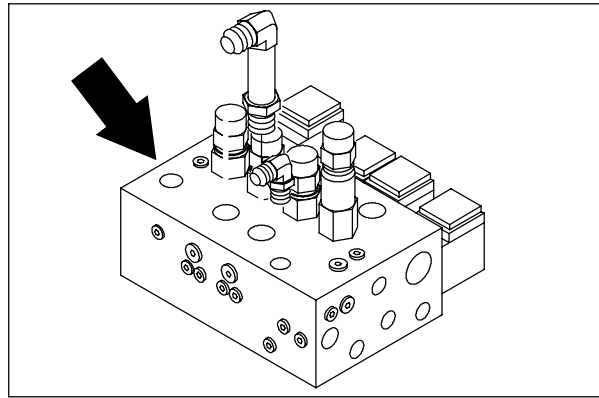

NOTE: Observe hydraulic cleanliness requirements when opening hydraulic lines.

7. Open the the brush door on the left side of the machine.
8. Remove the three M10 hex screws, washers, and nyloc nuts holding the scrubber valve assembly to the machine frame.
9. Remove the scrubber valve from machine and place it in a vice upside down.
10. Remove the three M8 hex screws holding the two mounting plates to the valve.
11. Turn the valve over in the vice and remove the hydraulic fittings.
12. Install fittings in the new valve in the same orientation.

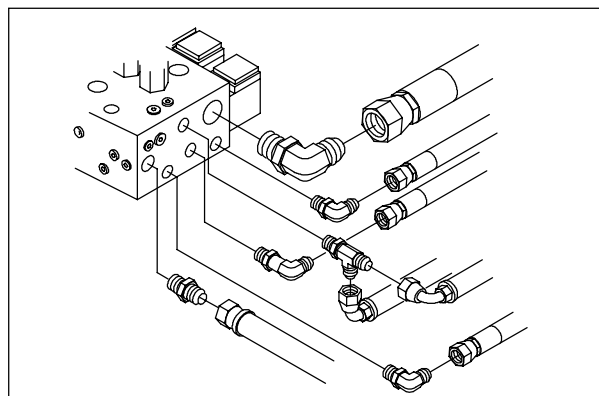
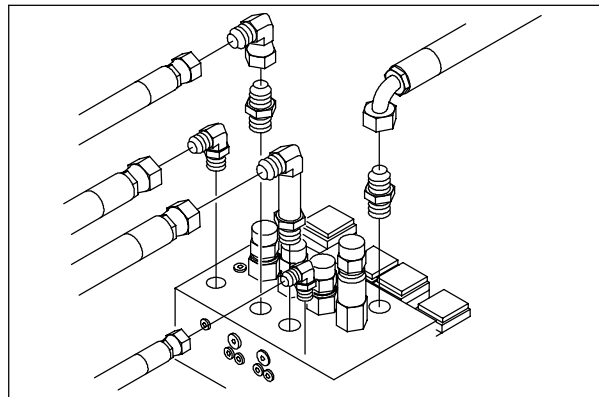

NOTE: Install the fittings in the new valve in the same orientation as they were removed.

HYDRAULICS

13. Reinstall the two mounting plates to the new scrubber valve. Reinstall the three M8 hex screws and tighten to 18 - 24 Nm (15 - 20 ft lb).
14. Position the new scrubber valve assembly back in the machine. Reinstall the three M10 hex screws, washers, and nyloc nuts. Tighten to 37 - 48 Nm (26 - 34 ft lb).

NOTE: Remember to put hex screws in from under the machine so the nyloc nuts are on valve side.

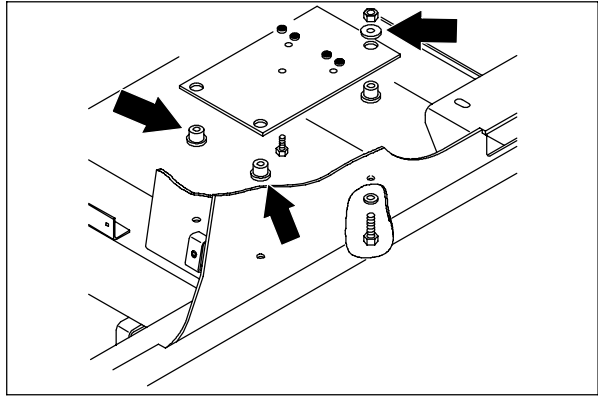

15. Reconnect the hydraulic hoses to scrubber valve. See the hydraulic schematic in this section.
16. Reconnect the electric solenoids to the main harness. See the schematic in the ELECTRICAL section of this manual.
17. Reconnect the battery cables to the battery.
18. Start the machine and operate the hydraulic scrubbing functions. Check the scrubber valve for any leaks and for proper operation.
19. Reinstall solution and recovery tanks. See TO INSTALL SOLUTION TANK instructions in the SCRUBBING section of this manual.

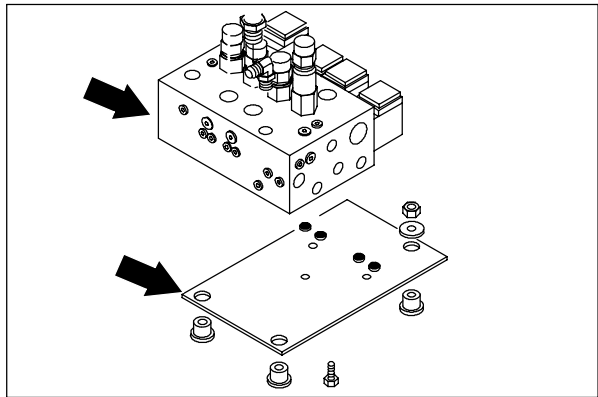

TO REPLACE SOLENOID VALVE CARTRIDGE

1. Shut off the engine and engage the parking brake.

FOR SAFETY: Before Leaving Or Servicing Machine; Stop On Level Surface, Set Parking Brake, Turn Off Machine And Remove Key.

2. Remove the battery cables from the battery.
3. Locate and identify the cartridge to be replaced. Unplug the solenoid from the main harness.
4. Remove the hex nut and rubber o-ring from the cartridge stem.
5. Slide electrical coil and rubber o-ring off the valve stem.

NOTE: Oil will run out of the valve when the cartridge is removed.

6. Remove the cartridge stem from the valve body.

NOTE: Observe hydraulic cleanliness requirements when opening hydraulic lines.

7. Install a new cartridge stem back in the valve port. Firmly hand tighten.

NOTE: Make sure the new cartridge had an o-ring installed and oiled.

8. Slip the o-ring and coil back over the new stem.
9. Install the o-ring and hex nut on the new stem. Lightly hand tighten.

NOTE: Do not over tighten--snug only.

10. Plug the solenoid coil back in the main harness. See schematic in ELECTRICAL section.
11. Reconnect the battery cables to the battery.
12. Start the machine and check the new cartridge for leaks.

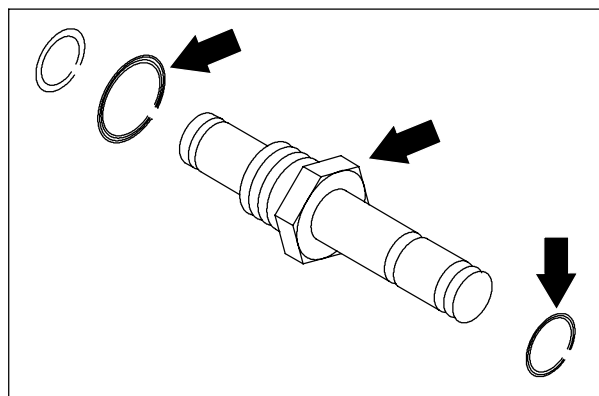
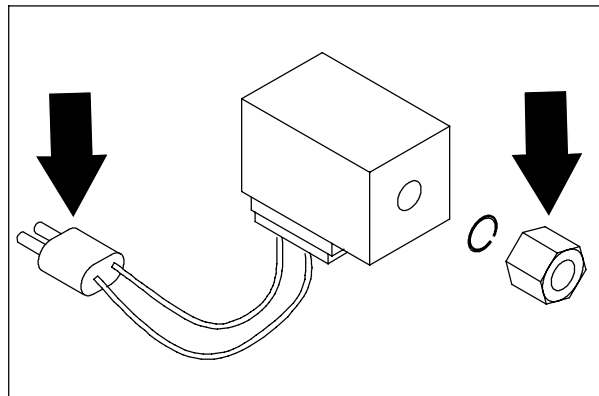
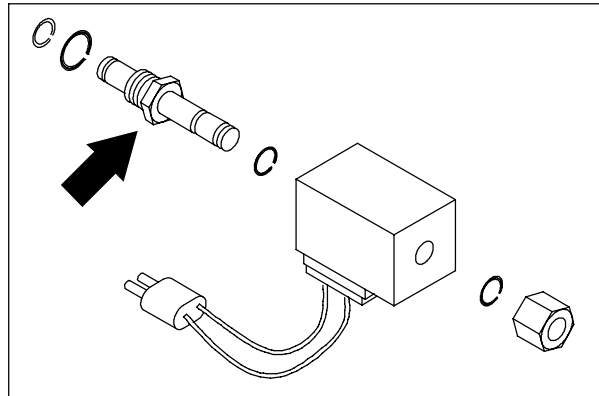

HYDRAULICS

TO REPLACE REAR DRIVE MOTOR

FOR SAFETY: Before Leaving Or Servicing Machine; Stop On Level Surface, Set Parking Brake, Turn Off Machine And Remove Key.

1. Engage the parking brake and block the front tires.
2. Jack up the rear of the machine. Use jack stands to support machine.

FOR SAFETY: Block machine tires before jacking machine up. Jack machine up at designated locations only. Block machine up with jack stands.

3. Remove the rear tire and wheel assembly.
4. Remove the slotted nut from drive wheel motor hub shaft.
5. Use a large puller to remove the drive hub from the motor shaft.

NOTE: Mark the hoses to make sure they are returned to the correct fitting when reassembled.

6. Remove and plug the hydraulic hoses leading to the drive motor.

NOTE: Observe hydraulic cleanliness requirements when opening hydraulic lines.

7. Remove the four drive motor mounting bolts.
8. Slide the motor out of the rear wheel housing.

NOTE: The orientation of the motor in the rear wheel housing.

9. Rebuild or replace drive motor. If you replace the drive motor, install the fittings on the new motor oriented the same as they were removed.
10. Slide the rebuilt or new motor in the rear wheel housing.

NOTE: The orientation of the motor in the rear wheel housing.

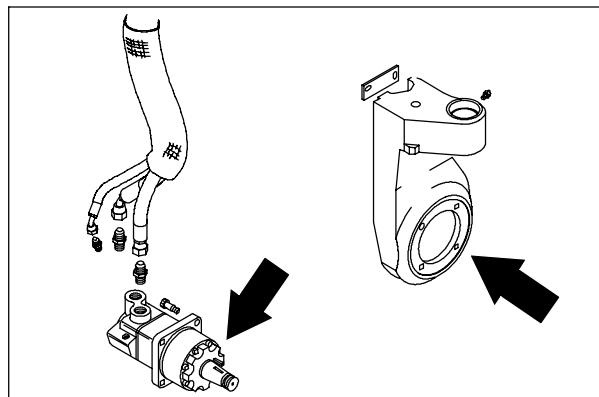
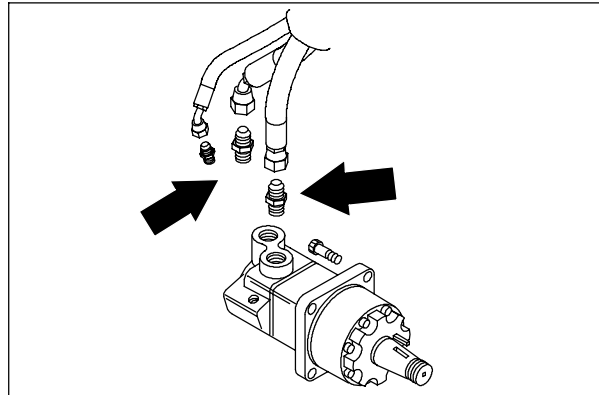
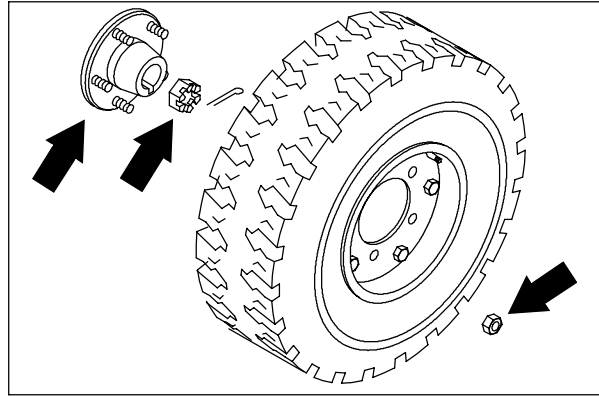

11. Install the four socket screws. Torque to 90 - 117 Nm (70 - 85 ft lb).
12. Reconnect the hydraulic hoses to the drive motor.

NOTE: Make sure the hoses are returned to the correct fitting when reassembled. See schematic in the HYDRAULICS section.

13. Install the drive hub to the tapered motor shaft. Tighten slotted nut to 500 Nm (375 ft lb). Install the cotter pin.

NOTE: Make sure the square key is in place on the tapered shaft before installing the drive hub.

14. Install rear tire and wheel assembly. Torque the rear wheel nuts to 142 - 156 Nm (105 - 115 ft lb).
15. Remove the jack stands and the lower machine.
16. Drive the machine and check for proper operation.

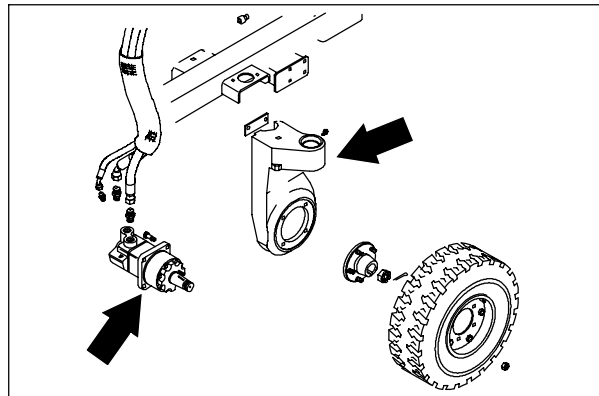
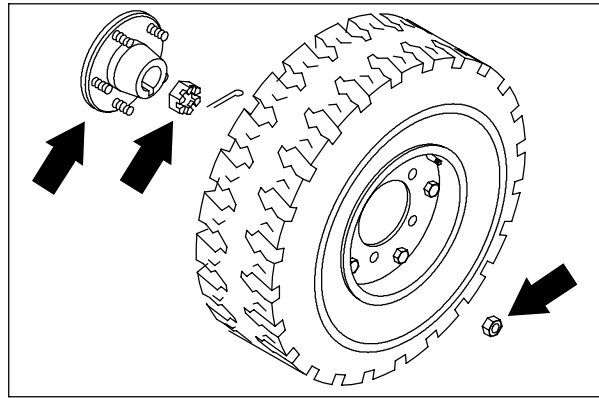

TO REPLACE SWEEPING VACUUM FAN HYDRAULIC MOTOR

1. Park the machine on a smooth, level surface.
2. Stop the engine and set the machine parking brake.

FOR SAFETY: Before Leaving Or Servicing Machine; Stop On Level Surface, Set Parking Brake, Turn Off Machine And Remove Key.

3. Remove the vacuum fan from the machine. See TO REMOVE SWEEPING VACUUM FAN instructions in this section.
4. Place the vacuum fan assembly in a vice.
5. Remove the four 0.25 in. hex screws and fender washers holding the inlet plate to the vacuum fan housing. Remove the plate.
6. Hold the impeller from turning and remove the 0.31 in. hex nut from the vacuum fan motor shaft.
7. Pull the impeller straight off the shaft. The impeller may have to be lightly pried off. Be careful not to loose the square key.
8. Remove the four M10 nyloc nuts holding the hydraulic motor plate to vacuum fan housing.
9. Remove the hydraulic motor and plate assembly from the vacuum fan housing.
10. Remove the four M8 flat head screws and nyloc nuts holding hydraulic fan motor to the motor plate.
11. Remove the hydraulic fittings and install in the new or rebuilt fan motor. Keep the same orientation.
12. Install the new motor on the motor plate using the four M8 flat head screws and nyloc nuts. Tighten to 18 - 24 Nm (13 - 18 ft lb).

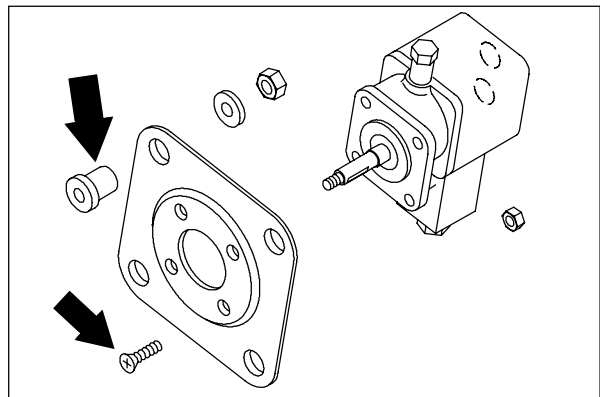
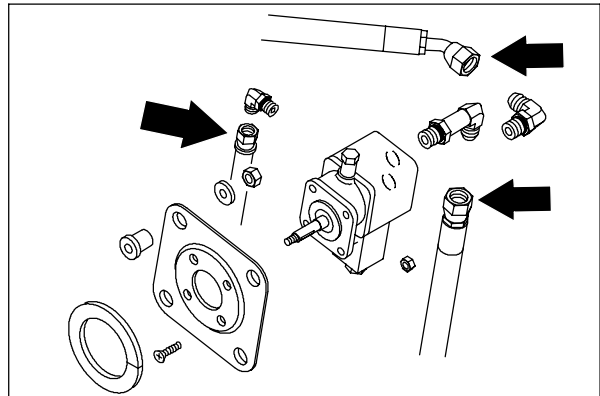
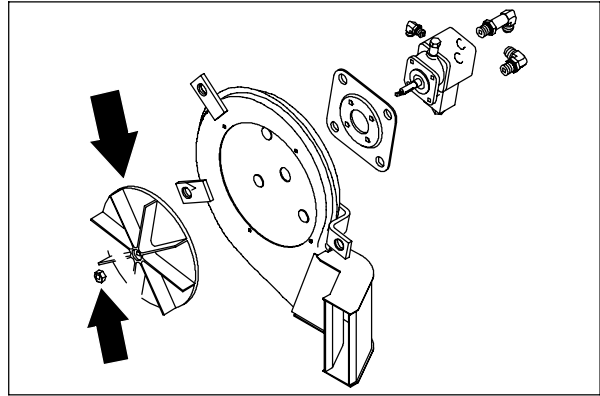
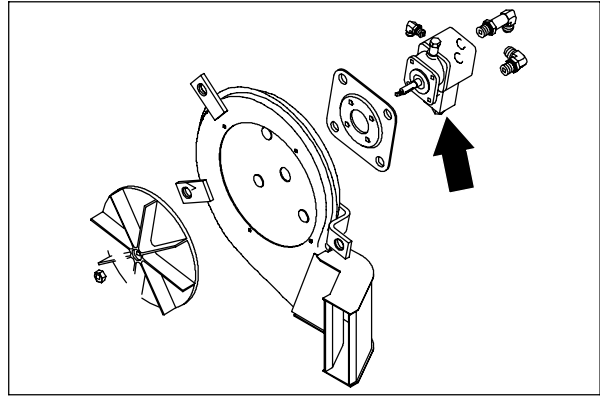

13. Reinstall the hydraulic motor and plate assembly back on the fan housing using four M10 nyloc nuts and flat washers. Tighten to 18 - 24 Nm (13 - 18 ft lb). The motor should be oriented with case drain fitting pointing toward the fan exhaust outlet.
14. Put a small amount of grease on the motor shaft before installing the new impeller. Make sure the square key is in place.
15. Slide the impeller all the way on the shaft and spin it slowly. If the impeller rubs on housing, remove and place a 0.38 in. flat washer on shaft under impeller and re-assemble. Repeat this procedure until the impeller spins freely.
16. Hold the new impeller from turning and firmly tighten the 0.31 in. flex lock nut.
17. Reinstall the inlet plate using the four 0.25 in. hex screws and fender washers. Tighten to 11 - 14 Nm (7 - 10 ft lb).
18. Reinstall vacuum fan assembly to the rear of the hopper. See TO INSTALL SWEEPING VACUUM FAN instructions in this section.

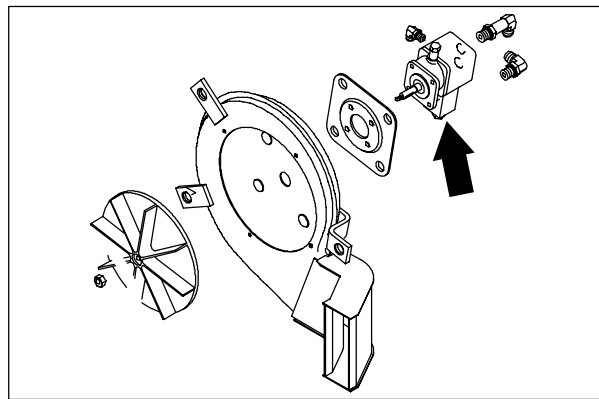
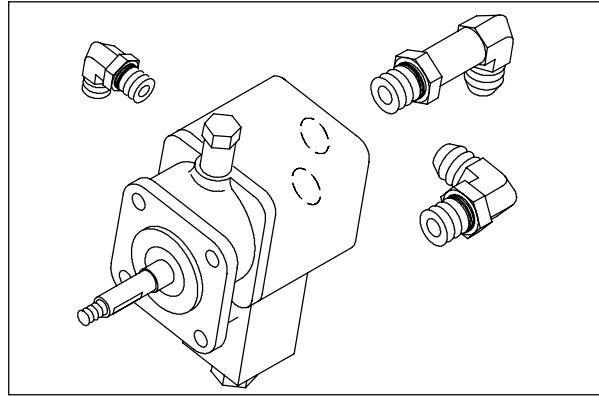

HYDRAULICS

TO REPLACE ENGINE COOLING FAN HYDRAULIC MOTOR

1. Shut off the engine and engage the parking brake.

FOR SAFETY: Before Leaving Or Servicing Machine; Stop On Level Surface, Set Parking Brake, Turn Off Machine And Remove Key.

2. Open the engine cover and side door.
3. Remove and plug the hoses connected to the cooling fan motor.

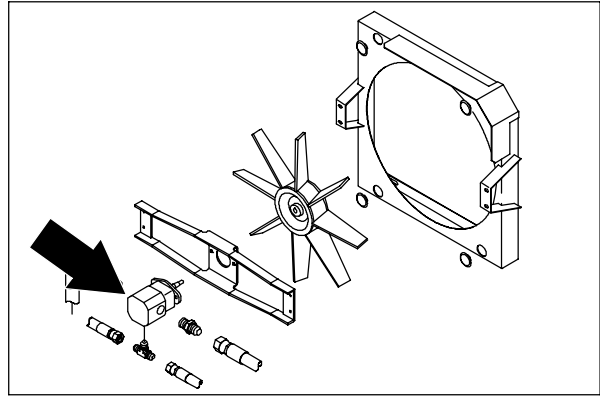

NOTE: Observe hydraulic cleanliness requirements when opening hydraulic lines.

4. Remove the four M6 hex screws and nyloc nuts holding the fan motor mount channel to the fan housing. Remove the cooling fan assembly from the machine.
5. Remove the hex nut from the fan motor shaft in center of fan blade.
6. Remove the fan blade from the motor shaft.

NOTE: A puller must be used to remove fan blade from tapered motor shaft.

7. Remove the four M8 hex screws holding the fan motor to mount channel. Remove the motor.
8. Remove the fittings from the old fan motor and install in the new motor in the same orientation.

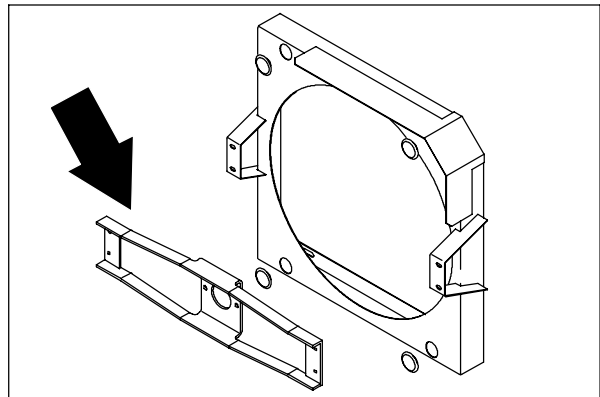
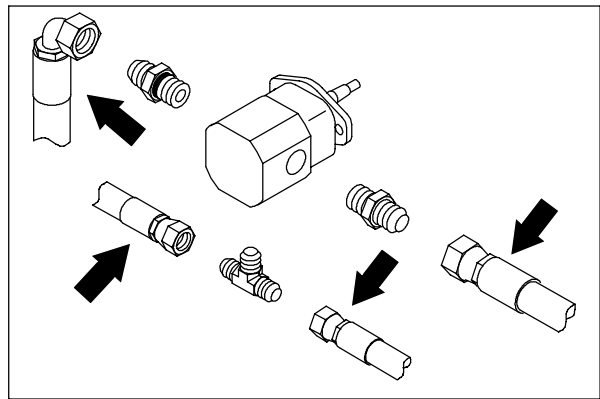

9. Install a new cooling fan motor on the mount channel. Reinstall the four M8 hex screws. Tighten to 18.5 - 24 Nm (16 - 21 ft lb).
10. Reinstall the fan blade on the new fan motor shaft.

NOTE: Make sure key is in place on motor shaft.

11. Reinstall the hex nut and tighten to 18.5 - 24 Nm (16 - 21 ft lb).

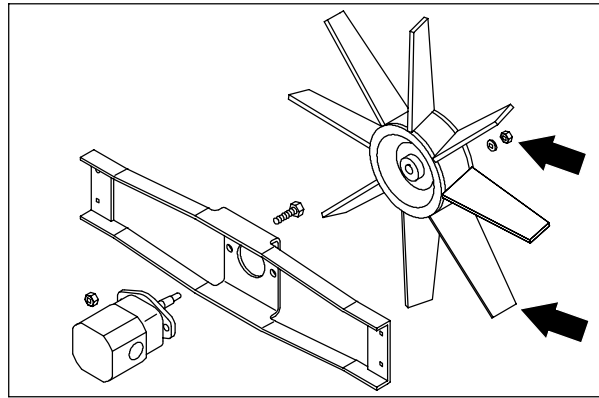

12. Reinstall the fan motor assembly on the fan housing. Reinstall the four M6 hex screws and nyloc nuts. Tighten to 7.6 - 9.9 Nm (5 - 7 ft lb).

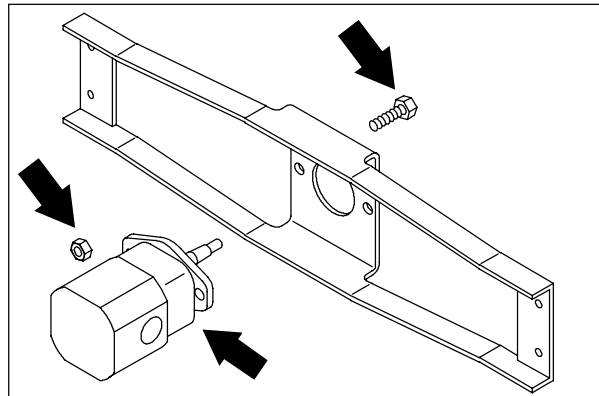

13. Reconnect the hydraulic hoses to the new cooling fan motor. See the hydraulic schematic in this section.
14. Start the machine and check the new cooling fan motor for leaks.

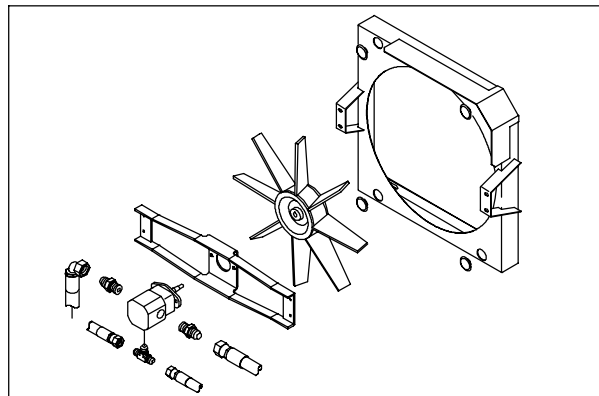

HYDRAULICS

TO REPLACE SCRUB VACUUM FAN HYDRAULIC MOTOR

FOR SAFETY: Before Leaving Or Servicing Machine; Stop On Level Surface, Set Parking Brake, Turn Off Machine And Remove Key.

1. Remove the scrub vacuum fan from the machine. See TO REMOVE SCRUB VACUUM FAN instructions in this section.
2. Place the vacuum fan assembly in a vice or other holding device.
3. Remove the six hex screws holding the front housing to the rear housing. Remove the front housing.

NOTE: The orientation of front housing to rear housing is very important. Mark both the front and rear housing for proper reassembly.

4. Remove the crown nut on the impeller shaft. Slide the impeller off the shaft.

NOTE: Remove and save the square key and any shims on the shaft under the impeller.

5. Turn the bottom housing over and remove the four nyloc nuts and washers from the motor mount plate. Remove the plate from the housing.

NOTE: Mark the orientation of hydraulic motor and fittings.

6. Remove the four flat head screws and nyloc nuts holding the hydraulic fan motor to the mounting plate.
7. Install a new motor on the mounting plate. Tighten the four flat head screws to 9 - 13 Nm (7 - 10 ft lb).
8. Remove the hydraulic fittings from the old motor. Install these fittings in the new motor in the same orientation as they were removed.
9. Reinstall the new motor and mounting plate on the rear housing. Tighten the four nyloc nuts to 16 - 22 Nm (12 - 16 ft lb).

NOTE: Make sure the motor is installed on the rear housing with the hydraulic motor in the correct orientation.

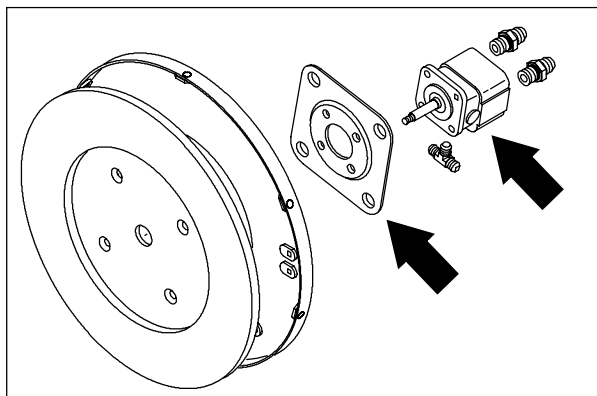
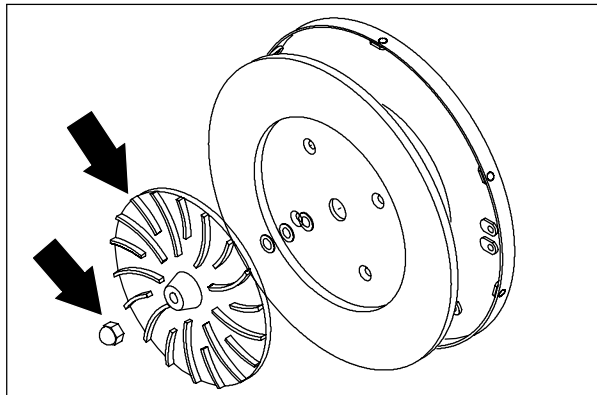
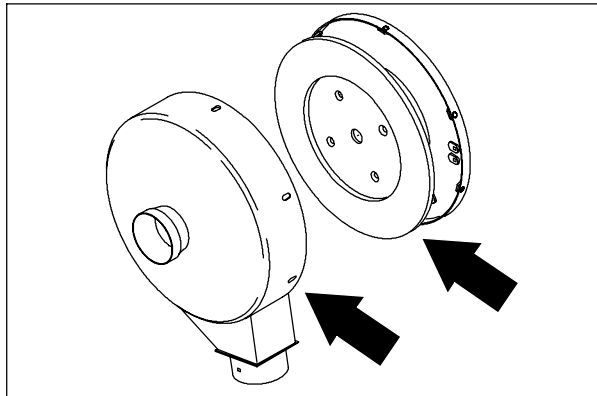
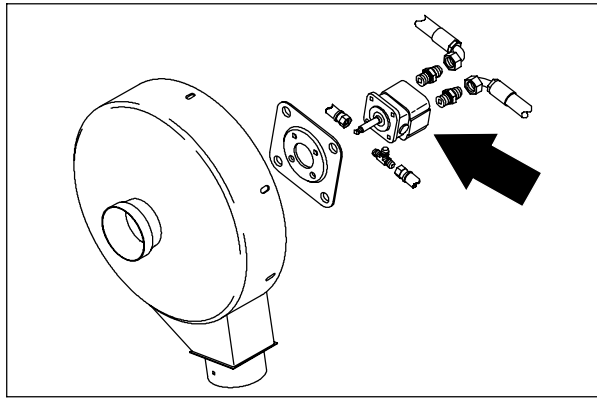

- Turn the rear housing over and reinstall the shims, key, fan impeller, and crown nut. Tighten nut to 34 - 47 Nm (25 - 35 ft lb).

NOTE: Be sure the key is on the shaft. Super gluing the key helps keep it in place.

NOTE: Use blue loctite 242 on shaft threads.

- Reinstall the front housing to the rear housing. Reinstall the six hex screws and tighten to 22 - 27 Nm (16 - 20 ft lb).

NOTE: Tennant part no. 57543 plastic shims must be used for proper fan to housing clearance. Remove these shims after housing has been tightened.

- Reinstall the vacuum fan assembly back in the machine. See TO INSTALL SCRUB VACUUM FAN instructions in this section.

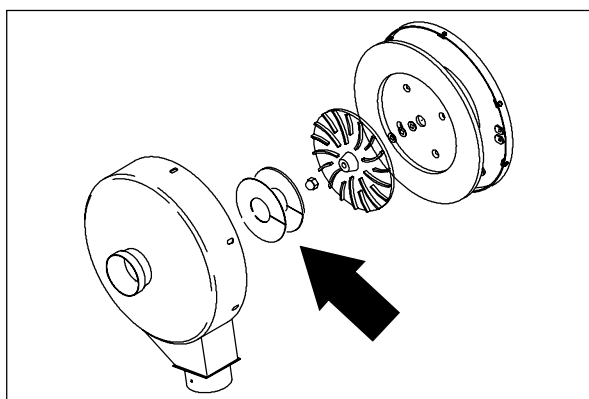
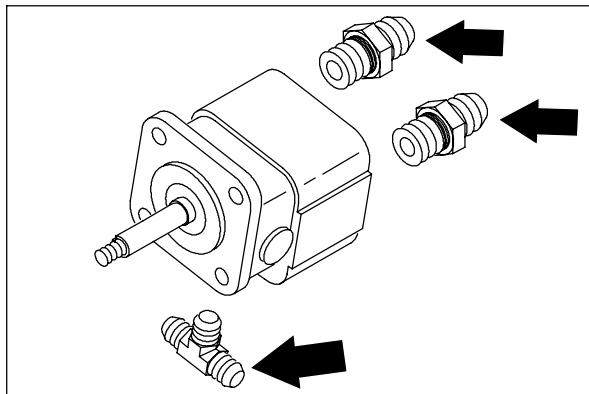

HYDRAULICS

TO REPLACE SCRUB BRUSH HYDRAULIC MOTOR

1. Start the engine, lower and side shift the scrub head, shut off the engine.

FOR SAFETY: Before Leaving Or Servicing Machine; Stop On Level Surface, Set Parking Brake, Turn Off Machine And Remove Key.

2. Raise the rear of machine using a hoist or floor jack.

FOR SAFETY: Block machine tires before jacking machine up. Jack machine up at designated locations only. Block machine up with jack stands.

3. Remove the cotter pin from the long horizontal clevis pin holding each side squeegee to the scrub head frame. Remove the clevis pins and squeegee assemblies from both sides.
4. Remove all three scrub brushes.

NOTE: Mark the hoses for proper re-assembly.

5. Remove and plug the hydraulic hoses connected to brush motor.

NOTE: Observe hydraulic cleanliness requirements when opening hydraulic lines.

6. Remove the 0.25 in. hex screw and spacer washer holding the brush drive hub to the brush hydraulic motor. Remove hub, spacer, and key.
7. Remove the four 0.38 in. hex screws holding the brush motor to the bracket. Note the orientation of the motor in the bracket and remove.
8. Remove the hydraulic fittings from the old motor and install in the same orientation in the new or rebuilt motor.
9. Install the new motor in the bracket in the same orientation it came out. Reinstall the four 0.38 in. hex screws and tighten to 31 - 40 Nm (27 - 35 ft lb).

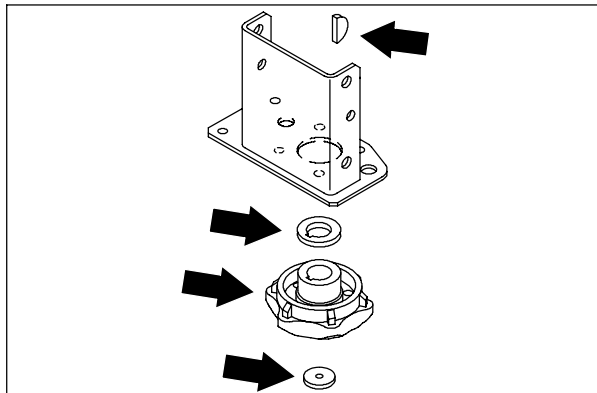
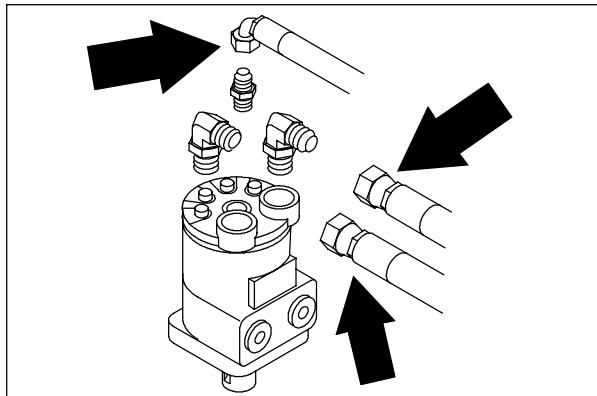
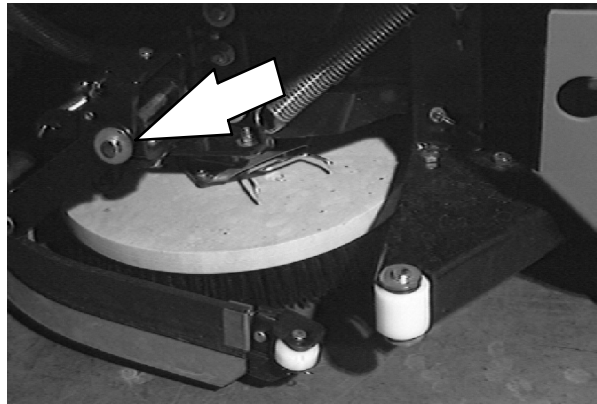
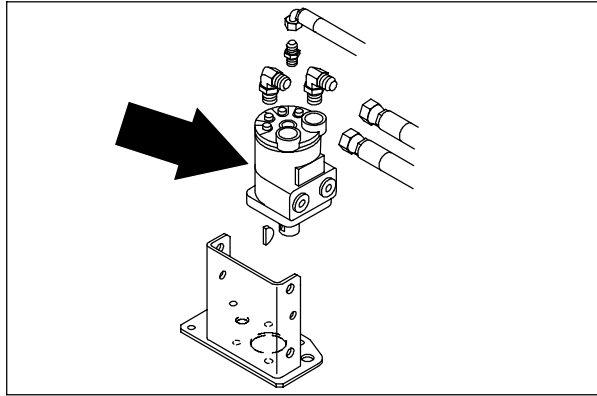

10. Reinstall the spacer, key, hub, washer, and 0.25 in. hex screw in the new brush motor shaft. Use blue loctite 242 in threads of the hex screw. Tighten to 11 - 14 Nm (7 - 10 ft lb).
11. Reconnect hydraulic hoses to brush motor. See schematic in HYDRAULICS section.

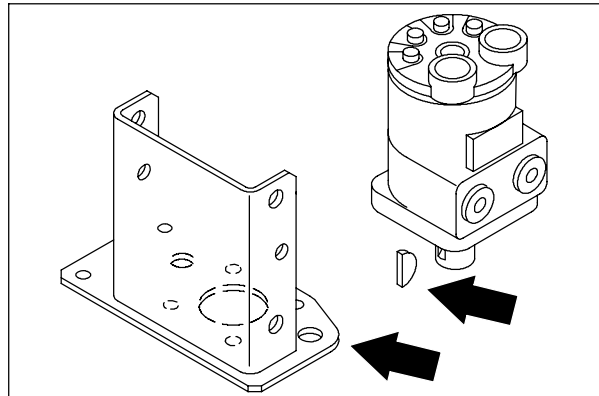

12. Reinstall the three disc brushes.
13. Reinstall the LH and RH side squeegees with the long clevis pins and cotter pins.
14. Lower the machine. Start the engine and check for any leaks and for proper operation of the scrub brushes.

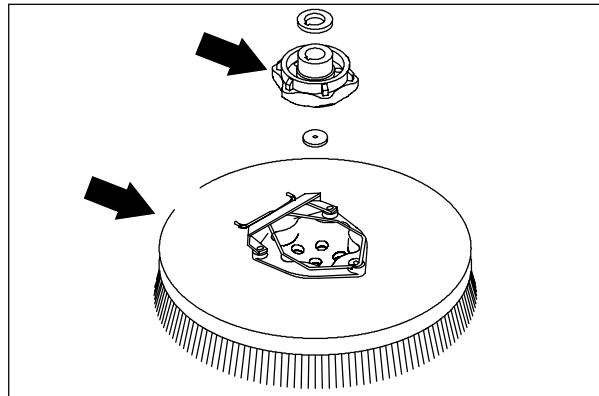

HYDRAULICS

TO REPLACE MAIN BRUSH HYDRAULIC MOTOR

FOR SAFETY: Before Leaving Or Servicing Machine; Stop On Level Surface, Set Parking Brake, Turn Off Machine And Remove Key.

1. Raise the hopper and engage the hopper support bar.

⚠ WARNING: Raised Hopper May Fall. Engage Hopper Support Bar.

2. Remove the main brush.
3. Remove and plug the hydraulic hoses leading to the main brush motor.

NOTE: Observe hydraulic cleanliness requirements when opening hydraulic lines.

4. Remove the cotter pin from castle nut at the end of brush drive plug.
5. Hold the brush drive plug from turning and remove the castle nut.
6. A puller must be used to remove brush drive plug from the tapered shaft on the brush motor.
7. Remove the four .375 in. hex screws holding the main brush motor to the main brush motor arm. The brush motor can now be removed from the machine.

NOTE: Mark the orientation of the brush motor before removal for proper reassembly.

8. Remove the hydraulic fittings from the old motor.
9. Install a new or rebuilt main brush motor in the main brush arm. Reinstall the four .375 in. hex screws and tighten to (27 - 53 ft lb).

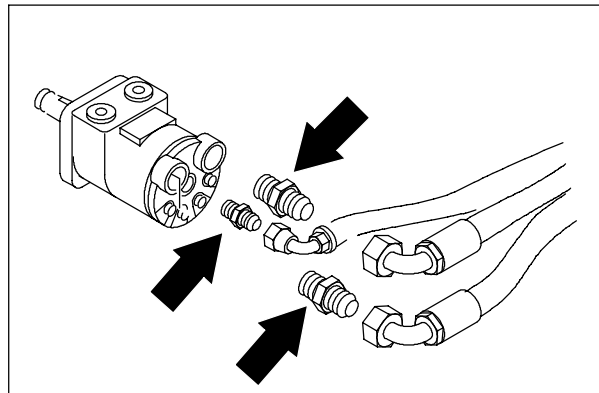
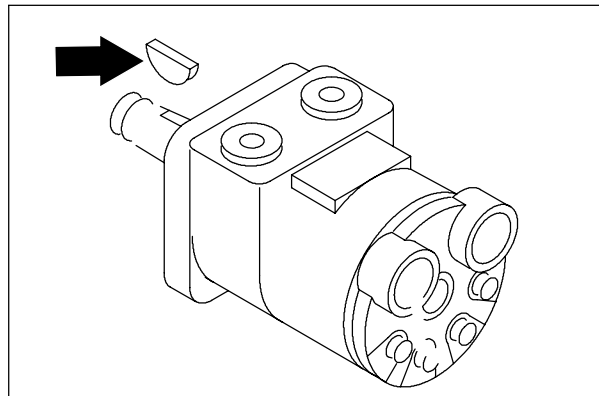
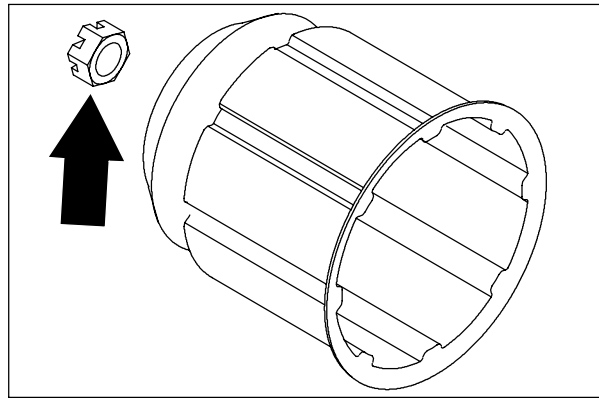
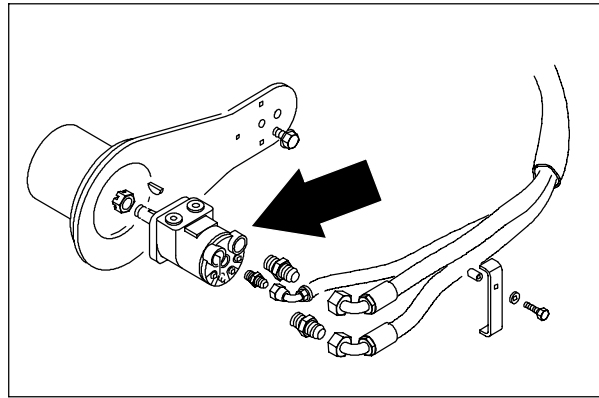

NOTE: Make sure the corners of brush motor line up with the slots in brush arm.

10. Reinstall the hydraulic fittings in the new motor.

NOTE: Make sure to orientate the fittings they way they were removed.

11. Reconnect the hydraulic hoses to the motor. See schematic in HYDRAULIC section.
12. Reinstall the brush drive plug on the tapered motor shaft. Make sure the square key is in place.
13. Reinstall the castle nut and tighten to 40 - 54 Nm (30 - 40 ft lb). Continue to tighten the castle nut until it lines up with the hole in brush motor shaft. Install a new cotter pin.
14. Reinstall the main brush.
15. Start the machine and run the main brush. Check for proper operation and leaks.

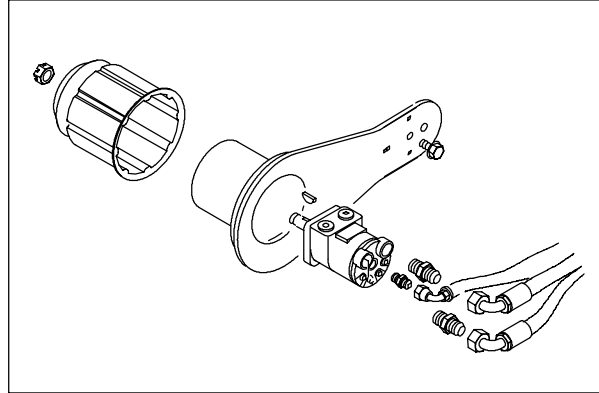

HYDRAULICS

TO REPLACE SIDE BRUSH MOTOR

1. Empty the debris hopper.
2. Set the machine parking brake.
3. Raise the hopper and engage the hopper support bar.



WARNING: Raised Hopper May Fall. Engage Hopper Support Bar.

4. Stop the engine.

FOR SAFETY: Before Leaving Or Servicing Machine; Stop On Level Surface, Set Parking Brake, Turn Off Machine And Remove Key.

5. Remove the side brush retaining pin from the side brush drive shaft by pulling the pin keeper off and over the end of the pin.
6. Slide the side brush off the side brush drive shaft.
7. Remove and plug hydraulic hoses from side brush motor.

NOTE: Observe hydraulic cleanliness requirements when opening hydraulic lines.

8. Remove the four .375 in. hex screws from bottom of side brush motor. Remove the side brush guard and side brush motor from machine.
9. Remove hydraulic fittings from the old motor.
10. Install a new or rebuilt side brush motor and side brush guard with the four .375 in. hex screws. Tighten to 31 - 40 Nm (27 - 35 ft lb).

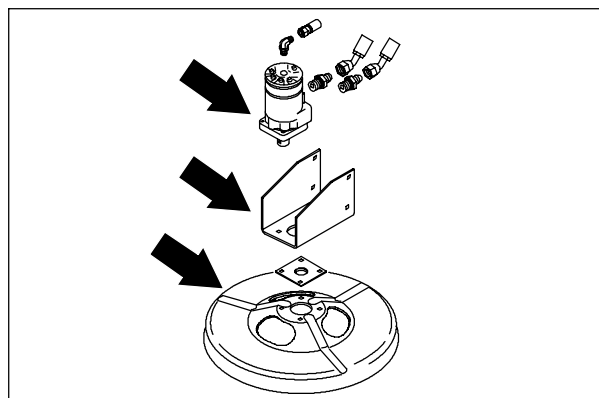
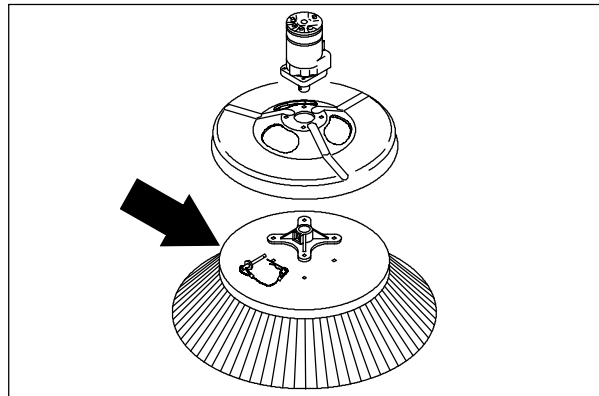
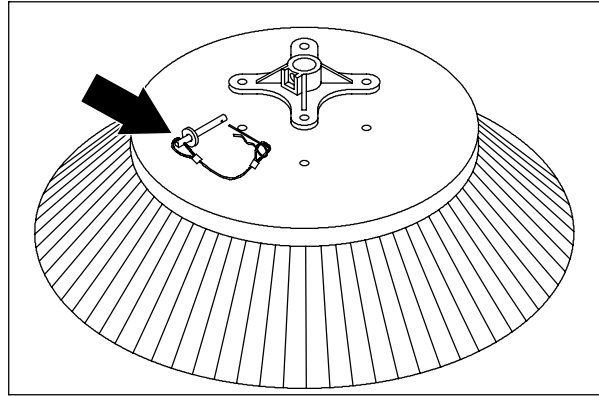

11. Reinstall the hydraulic fittings in the new motor.

NOTE: Make sure to orientate the fittings they way they were removed.

12. Reconnect the hydraulic hoses to the motor. See schematic in HYDRAULIC section.
13. Slide the side brush on the side brush drive shaft.
14. Insert the side brush retaining pin through the side brush hub and shaft.
15. Disengage the hopper support bar and lower the hopper.
16. Start the machine and run the side brush motor. Check for proper operation and leaks.

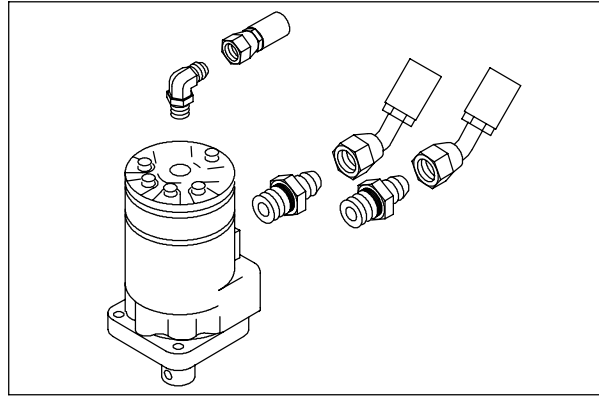

TO REPLACE STEERING CYLINDER

1. Start the engine and lower the scrub head. Shut off the engine.

FOR SAFETY: Before Leaving Or Servicing Machine; Stop On Level Surface, Set Parking Brake, Turn Off Machine And Remove Key.

2. Jack up the rear of the machine.

FOR SAFETY: Block machine tires before jacking machine up. Jack machine up at designated locations only. Block machine up with jack stands.

3. Disconnect the battery cables and remove the battery from machine.
4. **LPG machines;** Disconnect the LP tank and remove from the machine.
5. **Gas and Diesel machines;** Remove the four hex screws holding the right rear panel. Unplug the tail light and remove the panel. Disconnect the fuel lines at the tank. Remove the two tank straps and the fuel tank.
6. Turn the steering wheel half way to the left so the rear drive casting can be accessed from the fuel tank area of the machine.
7. Remove the clamp holding the drive motor hoses to rear casting. Move the hoses for access to steering cylinder attachment bolt.
8. Using a torque multiplier wrench; remove the .750" X 3.25" hex screw and nyloc nut holding the rod end of steering cylinder to the drive casting. Discard the hardware.
9. Using the access through the battery tray area; remove and plug the hydraulic hose near the rod end of the steering cylinder.

NOTE: Always observe hydraulic cleanliness requirements when opening hydraulic lines.

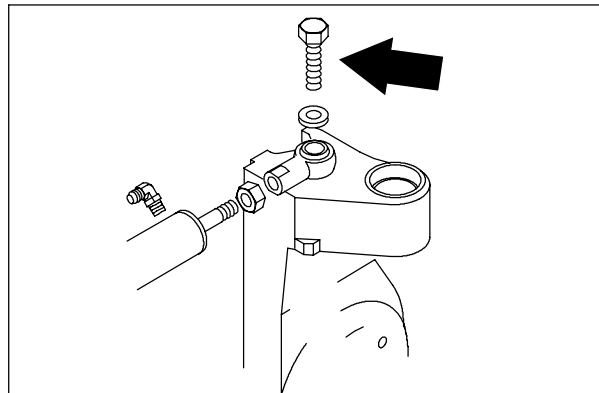
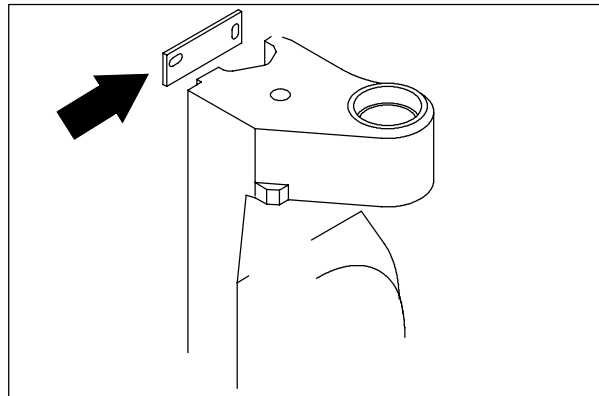
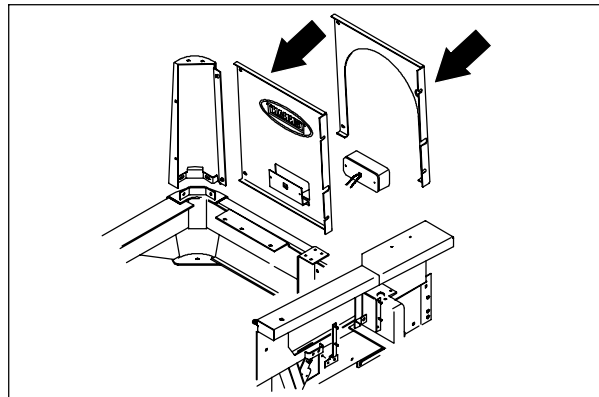
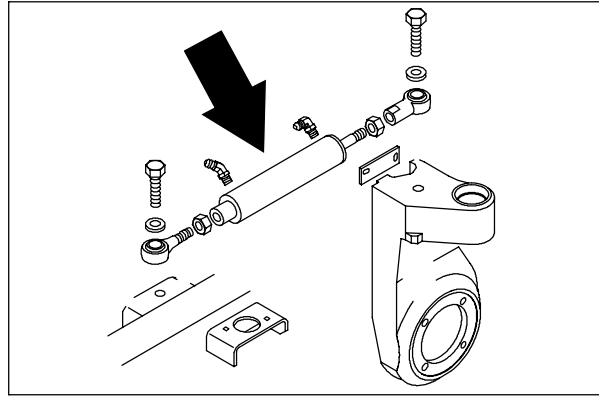

- Go under the machine from the operators compartment side. Remove and plug the hydraulic hose near the piston end of the steering cylinder.

NOTE: Always observe hydraulic cleanliness requirements when opening hydraulic lines.

- Go under the machine from the engine side and locate the .750" X 3.25" hex screw and nyloc nut holding the piston end of the steering cylinder to machine frame.
- Using the torque multiplier wrench, a 16" extension, and a long breaker bar, loosen and remove the .750" X 3.25" hex screw. Access to the nyloc nut is through the battery tray area. Discard the hardware.

NOTE: An extension should be added to the handle of the torque multiplier so it can be rested against the rear tire for leverage.

- Remove the steering cylinder from the machine.
- Remove the fittings from the old cylinder and install in the new cylinder. Install in the same orientation.
- Position the new cylinder and balljoint assembly in the machine with the rod end toward the rear drive casting.
- Install one new .750" X 3.25" hex screw and nyloc nut along with three washers between the balljoint and frame and one washer between the balljoint and nyloc nut in the piston end of the new steering cylinder.

NOTE: Washers must be installed for proper cylinder to frame clearance

- Using the torque multiplier wrench, a 16" extension, and a long ft lb torque wrench; tighten the .750" X 3.25" hex screw to 200-220 ft lb. Access to the nyloc nut is through the battery tray area.

NOTE: An extension should be added to the handle of the torque multiplier so it can be rested against the rear tire for leverage.

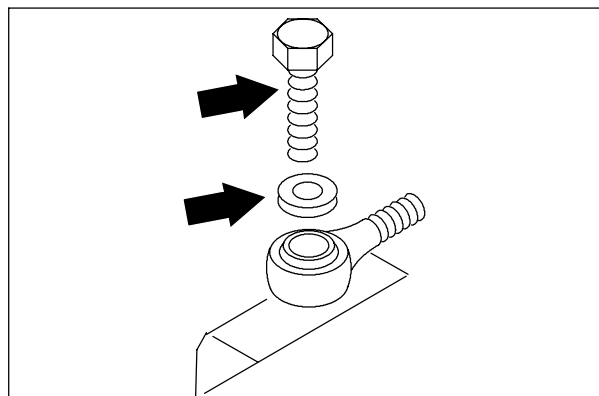
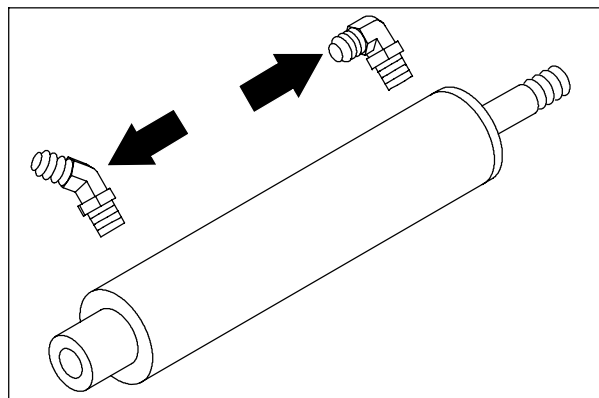
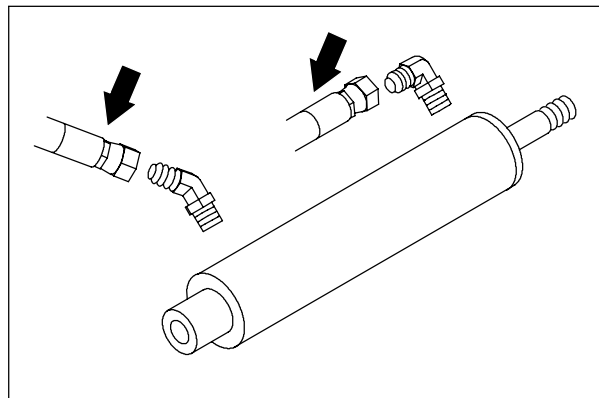
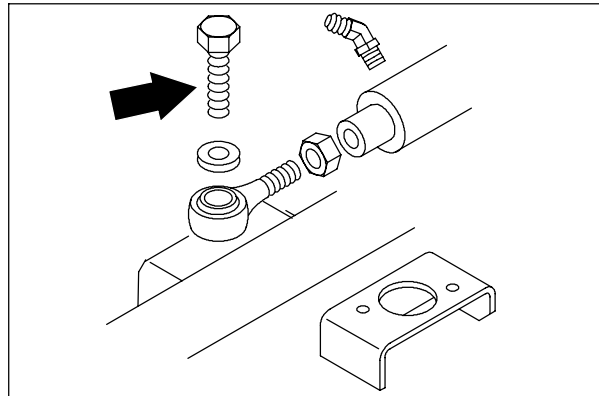

HYDRAULICS

18. Go to the rear of the machine and install a new .750" X 3.25" hex screw and nyloc nut along with three washer between balljoint and casting and one washer between balljoint and hex screw in the rod end of the new steering cylinder.

NOTE: Washers must be installed for proper cylinder to frame clearance

19. Using the torque multiplier and a long ft lb torque wrench; tighten the .750" X 3.25" hex screw to 200-220 ft lb.
20. Use the access in the battery tray area and reconnect the hydraulic hose near the rod end of steering cylinder.

NOTE: Always observe hydraulic cleanliness requirements when opening hydraulic lines.

21. Go under the machine from the operators compartment side and reconnect the hydraulic hose near the piston end of steering cylinder.
22. Reinstall the clamp holding the drive motor hoses to the rear casting.
23. **LPG machines;** Reinstall the LP tank.
24. **Gas and Diesel machines;** Reinstall the fuel tank and straps. Reconnect the fuel lines. Reinstall the rear panel and hardware. Reconnect the tail light wires.
25. Reinstall the battery and reconnect the cables.
26. Remove the jack stands and lower the machine.
27. With the seat in the raised position, start the machine and turn steering wheel in both directions. Observe steering cylinder for any leaks.

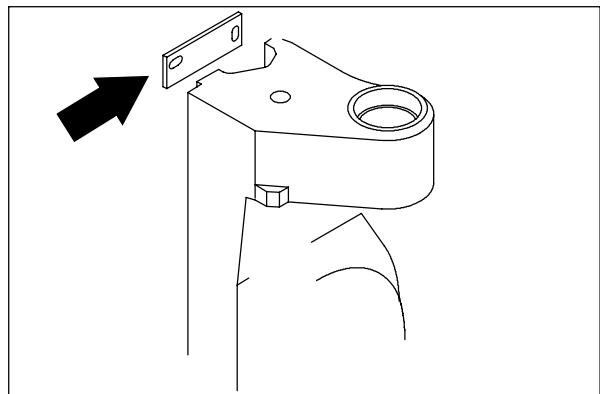
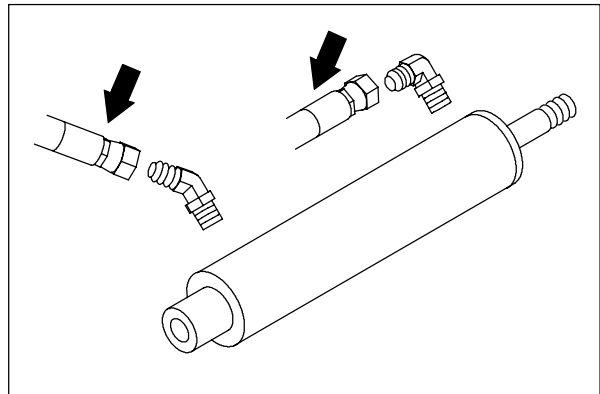
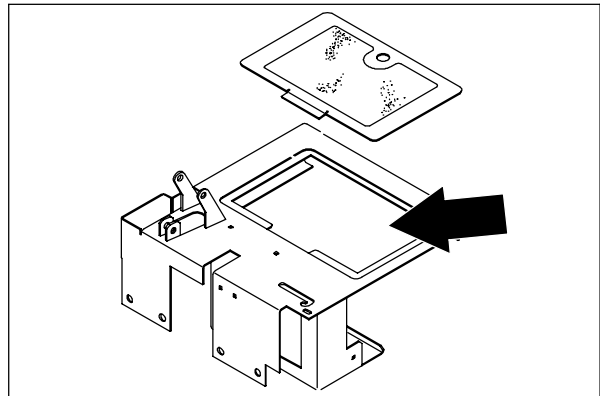
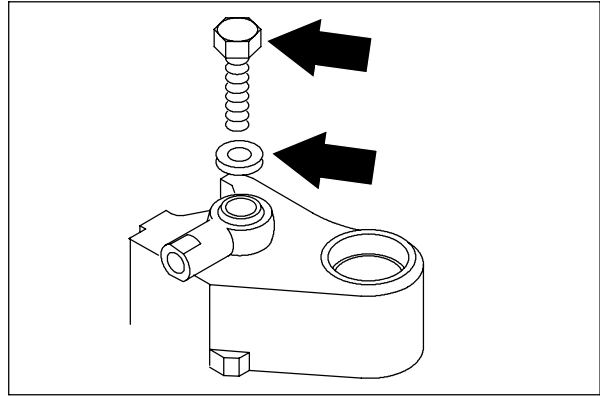

TO REPLACE HOPPER LIFT CYLINDER

1. Set the machine parking brake.
2. Raise the hopper and engage the prop arm. Drop the hopper down on the prop rod to relieve pressure on the cylinders.

FOR SAFETY: Before Leaving Or Servicing Machine; Stop On Level Surface, Set Parking Brake, Turn Off Machine And Remove Key.

3. Disconnect and cap the two hydraulic hoses leading to the hopper lift cylinder.

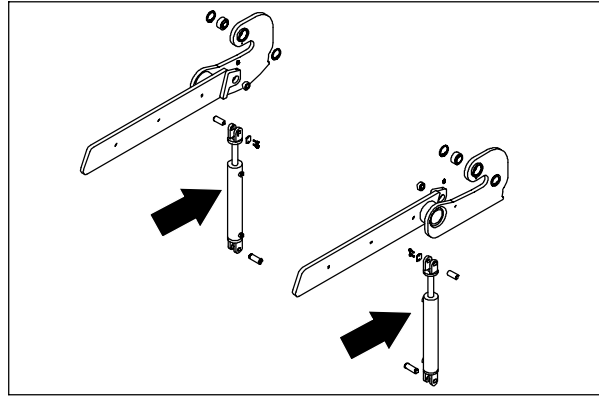

NOTE: Always observe hydraulic cleanliness requirements when opening hydraulic lines.

4. Remove the M6 hex screw holding the cylinder pin plate to the cylinder clevis.
5. Remove and retain one of the "C" clips from the grooved pin in the upper clevis of the lift cylinder. Remove the grooved pin.
6. Remove and retain one of the "C" clips from the grooved pin in the lower clevis of the lift cylinder. Remove the grooved pin. Remove the old lift cylinder from the machine.
7. Remove the fittings from the old cylinder and install in the new cylinder in the same orientation.
8. Position the new cylinder in the machine with the rod end pointing up.
9. Align the bottom of the lift cylinder with the hole in the frame mount lug. Reinstall the grooved pin and "C" clip.
10. Align the small bearing in the lift arm with the hole in the lift cylinder clevis.
11. Reconnect the hydraulic hoses to the new lift cylinder. See schematic in this section.
12. Start the machine and raise the hopper. Check for any leaks and proper operation.

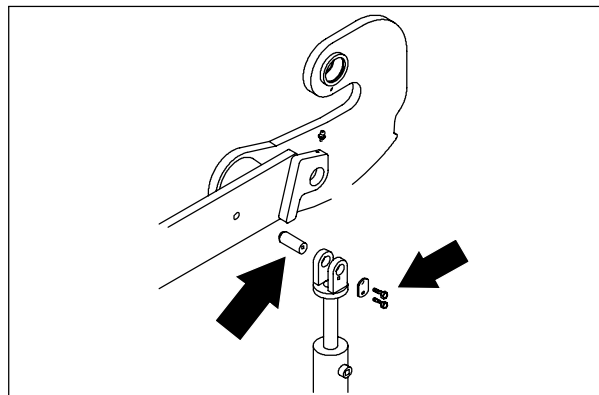
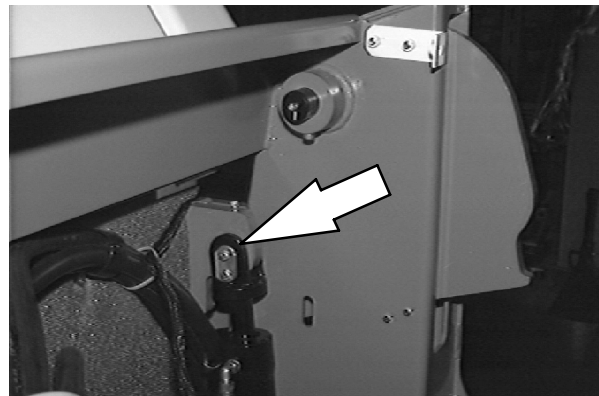

HYDRAULICS

TO REPLACE HOPPER DUMP DOOR CYLINDER

1. Set the machine parking brake.

FOR SAFETY: Before Leaving Or Servicing Machine; Stop On Level Surface, Set Parking Brake, Turn Off Machine And Remove Key.

2. Open the hopper cover.
3. Disconnect and plug the two hoses leading to the hopper dump door cylinder.
4. Remove the retaining ring from the front cylinder mount pin.
5. Remove the cotter pin and clevis pin from the rear of the dump door cylinder where it attaches to the pivot yoke.
6. Remove the old cylinder from the hopper.
7. Remove the fittings from the old cylinder and install in the new cylinder in the same orientation.
8. Position the new cylinder in the machine with the rod end pointing to the rear of the machine hopper.
9. Slip the piston end of the new cylinder over the pin on the hopper. Reinstall the retaining ring.
10. Reinstall the clevis pin and cotter pin in the rod end of the dump door cylinder and the door pivot yoke.
11. Reconnect the hydraulic hoses to the dump door cylinder. See the schematic in this section.
12. Start the machine and open and close the hopper dump door. Check for any leaks and proper operation.

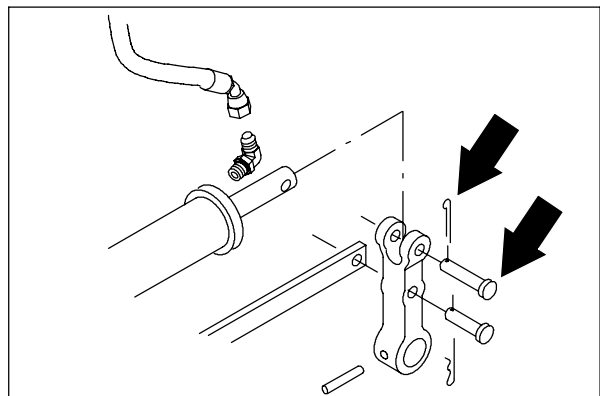
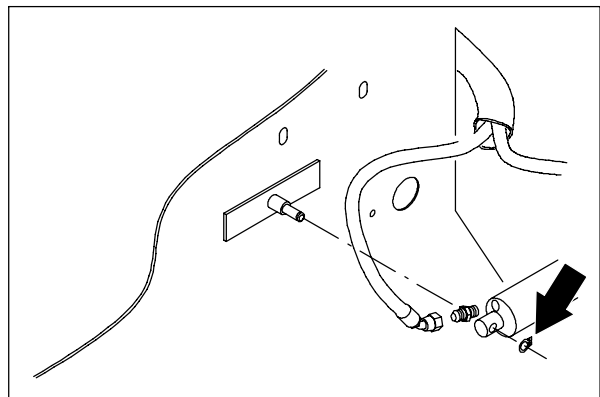
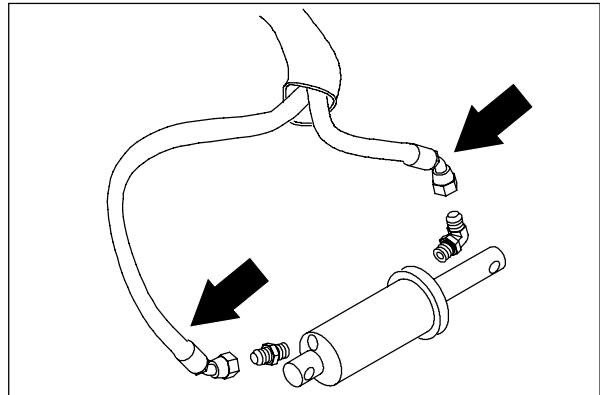
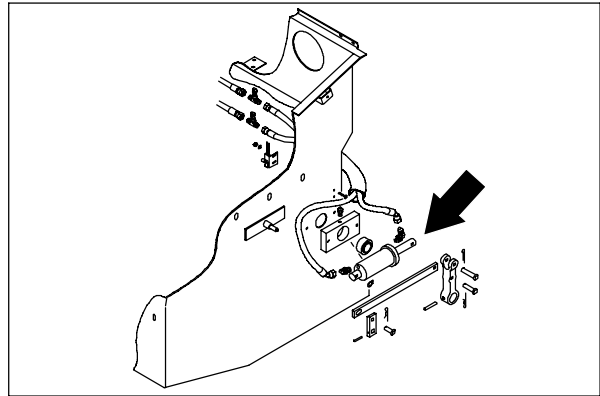

TO REPLACE MAIN BRUSH LIFT CYLINDER

1. Start the engine and lower the main brush. Shut off the engine.

FOR SAFETY: Before Leaving Or Servicing Machine; Stop On Level Surface, Set Parking Brake, Turn Off Machine And Remove Key.

2. Remove the solution and recovery tanks. See TO REMOVE SOLUTION TANK instructions in the SCRUBBING section.
3. Locate the clevis pin holding the main brush lift cable to the main brush lift arm. Remove the cotter pin and clevis pin.
4. Start the engine and raise the main brush. Shut off the engine.
5. Locate the two M10 hex nuts holding the two plastic tubes to the rod end of the main brush lift cylinder.

NOTE: Make sure cylinder is all the way retracted before removing springs.

6. Remove the hex nuts, tension springs, plastic tubes, main brush lift cable and threaded rod.
7. Disconnect and plug the two hydraulic hoses leading to the main brush lift cylinder.

NOTE: Observe hydraulic cleanliness requirements when opening hydraulic lines.

8. Remove the cotter pin and clevis pin holding the piston end of the main brush lift cylinder to the machine frame.
9. Remove the lift cylinder from the machine.

NOTE: Remember to orientate the fittings as close as possible to the way they came out.

10. Remove the hydraulic fittings from old main brush lift cylinder and install in the new cylinder in the same orientation.

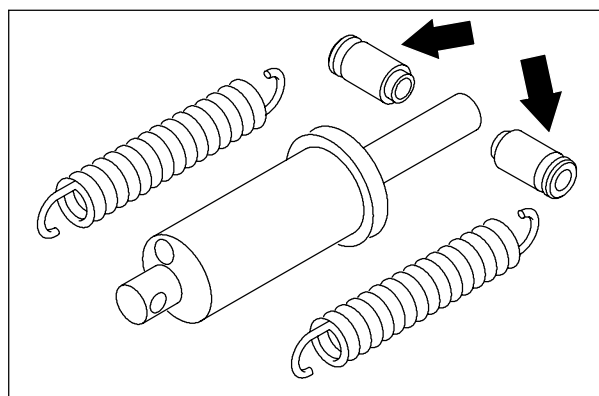
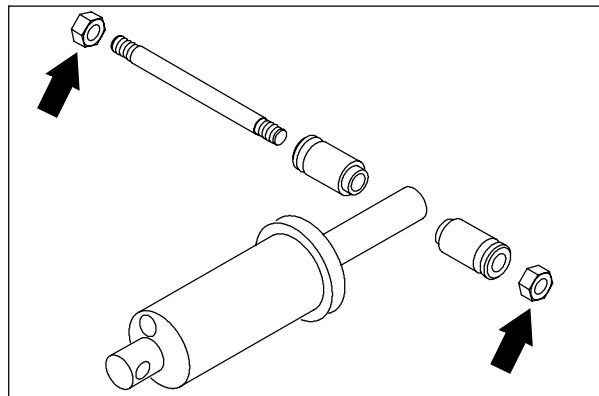
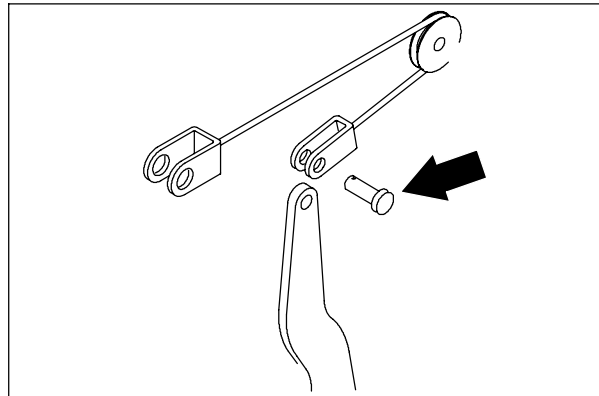
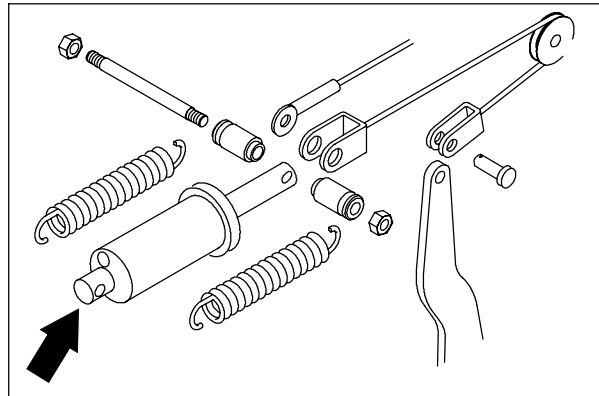

HYDRAULICS

11. Position the new main brush lift cylinder in the machine. Align the mount hole in piston end of the lift cylinder with hole in the mount bracket on the machine frame.
12. Reinstall the clevis pin and cotter pin.

NOTE: Make sure cylinder is all the way retracted before installing springs.

13. Reinstall the threaded rod, plastic tubes, main brush lift cable, M10 hex nuts, and tension springs to the rod end of the lift cylinder. Hand tighten hex nuts.
14. Reconnect the hydraulic hoses to the main brush lift cylinder. See the schematic in this section.
15. Start engine and lower the main brush. Shut off the engine.
16. Reconnect the main brush lift cable to the main brush lift arm using the clevis pin and cotter pin.
17. Start the engine and run the main brush up and down. Check for leaks and proper operation.
18. Reinstall solution and recovery tanks. See TO INSTALL RECOVERY TANK instructions in the SCRUBBING section.

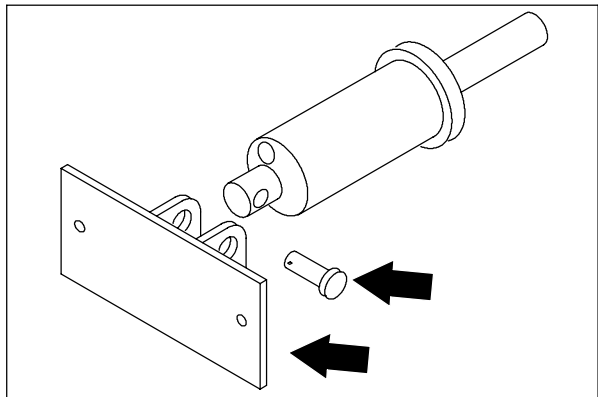
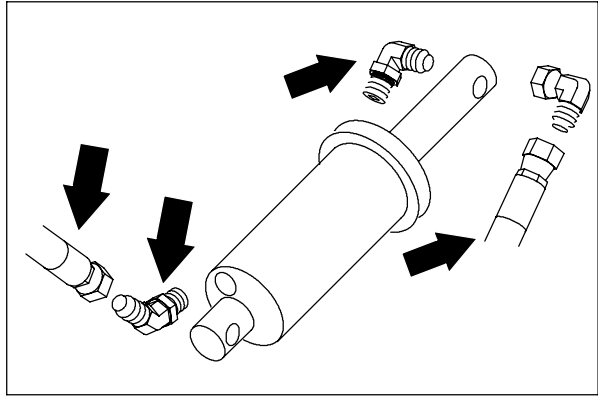

TO REPLACE SIDE BRUSH LIFT CYLINDER

1. Start the engine and raise the side brush. Shut off the engine.

FOR SAFETY: Before Leaving Or Servicing Machine; Stop On Level Surface, Set Parking Brake, Turn Off Machine And Remove Key.

2. Open the hopper cover.
3. Disconnect the tension spring from the bracket on the side brush lift cylinder and cable.
4. Start the machine and lower the side brush.
5. Disconnect and plug the two hydraulic hoses leading to the side brush lift cylinder.

NOTE: Observe hydraulic cleanliness requirements when opening hydraulic lines.

6. Remove the two hex screws holding the lift cylinder to the hopper bumper and side brush lift cable. Remove the lift cylinder from the machine.
7. Remove the hydraulic fittings from the old cylinder and install in the new cylinder in the same orientation.

8. Position the new cylinder on the machine and reinstall the two hex screws and nyloc nuts. Make sure the side brush lift cable is attached to the rod end of the lift cylinder.
9. Reconnect the two hydraulic hoses. See schematic in the HYDRAULICS section.
10. Start the machine and raise the side brush.
11. Reconnect the tension spring to the brackets. Close the hopper cover.

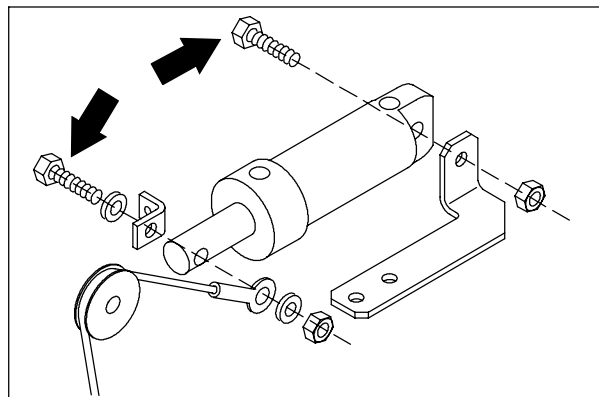
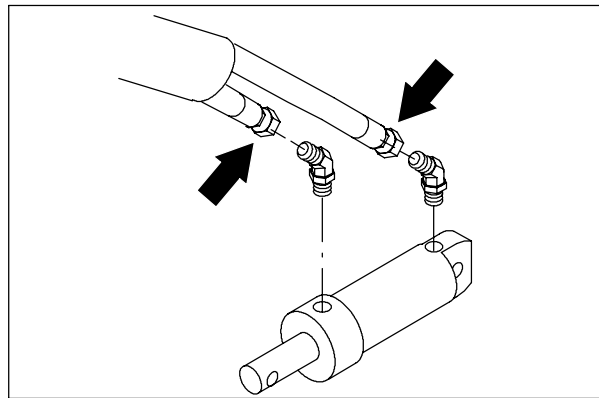
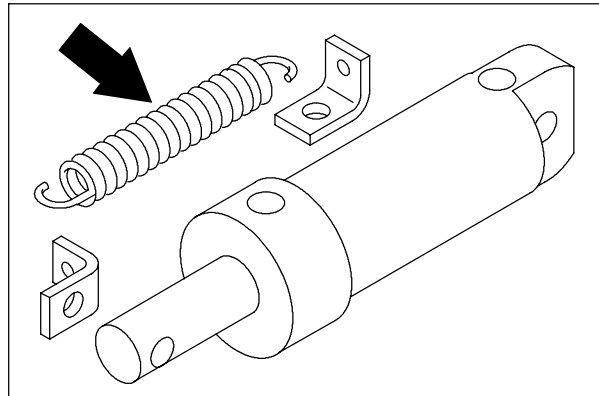

TO REPLACE SQUEEGEE LIFT CYLINDER

1. Start the engine, lower the rear squeegee, shut off the engine.

FOR SAFETY: Before Leaving Or Servicing Machine; Stop On Level Surface, Set Parking Brake, Turn Off Machine And Remove Key.

2. Raise the rear of machine using a hoist or floor jack.

FOR SAFETY: Block machine tires before jacking machine up. Jack machine up at designated locations only. Block machine up with jack stands.

3. Remove the M8 hex screw, nyloc nut, and spacer tube from the rear squeegee lift cable where it attaches at the center of the rear squeegee frame.

NOTE: The squeegee frame will drop down when the hex screw is removed.

NOTE: Mark the hoses for proper re-assembly.

4. Remove and plug the hydraulic hoses connected to the rear squeegee lift cylinder.

NOTE: Observe hydraulic cleanliness requirements when opening hydraulic lines.

5. Remove the snap retaining ring from the grooved pin on the pivot plate on the piston end of the squeegee lift cylinder.
6. Remove the cotter pin and clevis pin from the rod end of the lift cylinder and squeegee lift bellcrank.
7. The squeegee lift cylinder can now be pulled off the mount pin and removed from the machine.
8. Remove the hydraulic fittings and install in the new cylinder in the same orientation.

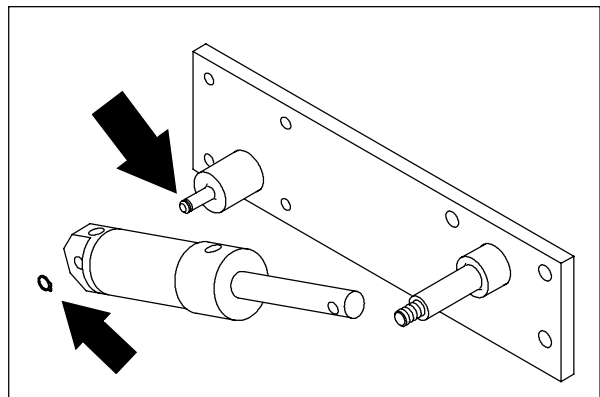
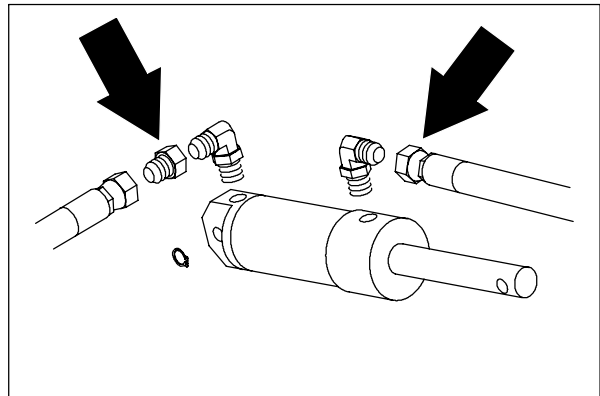
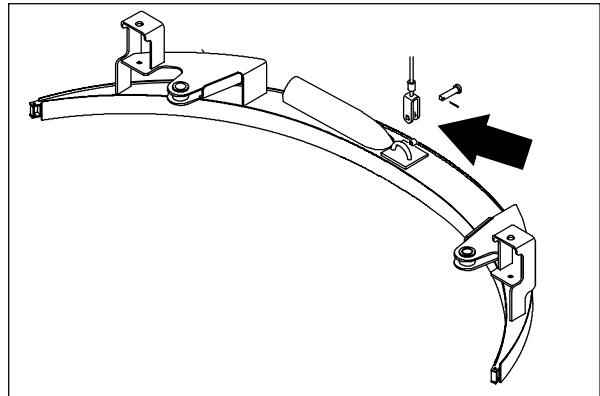
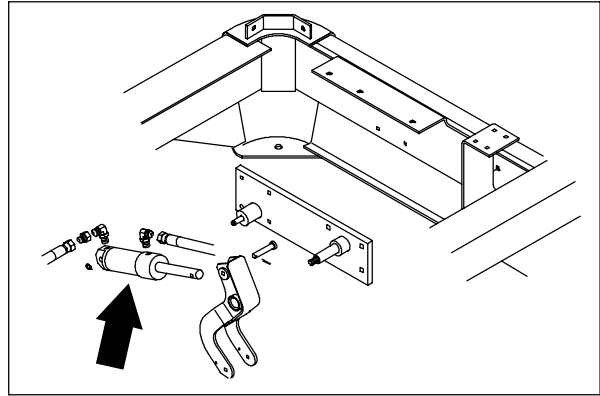

9. Position the new cylinder back in the machine. Place the hole in the piston end of the squeegee lift cylinder on the grooved mount pin on frame. Reinstall the snap ring retainer.
10. Align the hole in the rod end of the new squeegee lift cylinder with hole in the squeegee lift bellcrank. Reinstall the clevis and cotter pin.
11. Reconnect the hydraulic hoses to squeegee lift cylinder. See the schematic in the HYDRAULICS section.
12. Lift the squeegee assembly up until the hole in the lower end of the lift cable lines up with the hole in the squeegee frame. Reinstall the M8 hex screw, nyloc nut, and spacer tube. Tighten to 18 - 24 Nm (13 - 18 ft lb).
13. Lower machine and check for proper rear squeegee lift cylinder operation.

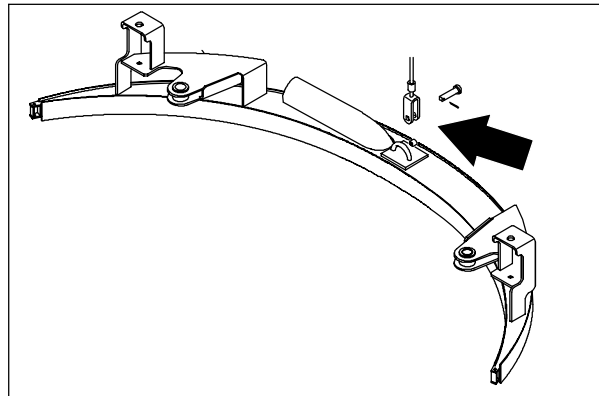
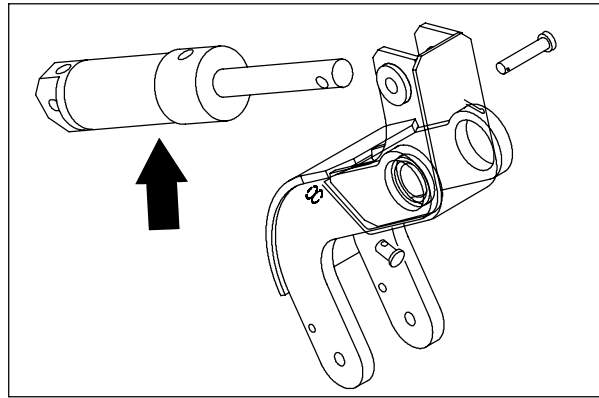

HYDRAULICS

TO REPLACE SCRUB BRUSH LIFT CYLINDER

1. Start the engine, lower and side shift the scrub head, shut off the engine.

FOR SAFETY: Before Leaving Or Servicing Machine; Stop On Level Surface, Set Parking Brake, Turn Off Machine And Remove Key.

2. Raise the rear of machine using a hoist or floor jack.

FOR SAFETY: Block machine tires before jacking machine up. Jack machine up at designated locations only. Block machine up with jack stands.

3. Remove the cotter pin from the long horizontal clevis pin holding each side squeegee to the scrub head frame. Remove the clevis pins and squeegee assemblies from both sides.
4. Remove all three scrub brushes.
5. Remove the 0.25 in. eye bolt holding the tension spring to the scrub brush motor bracket.

NOTE: Mark the hoses for proper re-assembly.

6. Remove and plug the hydraulic hoses connected to the scrub brush lift cylinder.

NOTE: Observe hydraulic cleanliness requirements when opening hydraulic lines.

7. Remove the cotter pin from the clevis pin holding the rod end of cylinder to the lower link. Remove the clevis pin.
8. Remove the 0.38 in. nyloc nut, washer, and hex screw holding the piston end of the lift cylinder to the top of the squeegee frame. The lift cylinder can now be removed from the scrub frame.
9. Remove the hydraulic fittings from the old cylinder and install in the same orientation in the new or rebuilt lift cylinder.

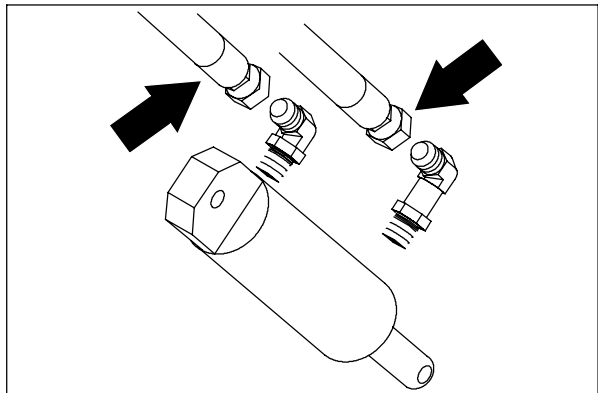
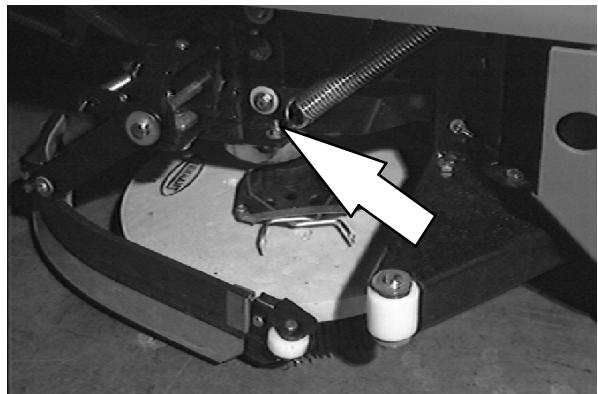
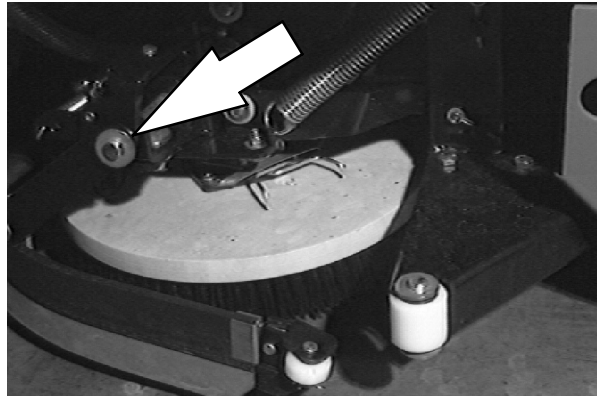
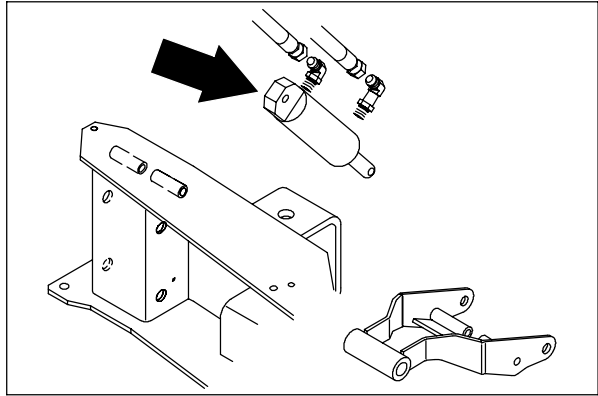

10. Position the new lift cylinder back in the scrub head frame. Align the hole in the piston end of the cylinder with the hole in the top of the frame. Reinstall the 0.38 in. hex screw, washers, and nyloc nut. Firmly tighten the hardware.
11. Raise the lower link up until the hole in the rod end of the lift cylinder lines up with the hole in the bracket. Reinstall the clevis pin and cotter pin.
12. Reconnect the hydraulic hoses to the lift cylinder. See the schematic in HYDRAULIC section.
13. Reinstall the eye bolt and tension spring. Firmly tighten the nyloc nut.
14. Reinstall the three disc brushes.
15. Reinstall the LH and RH side squeegees with the long clevis pins and cotter pins.
16. Lower the machine. Start the engine and check for any leaks and for proper operation of the scrub brush lift cylinder.

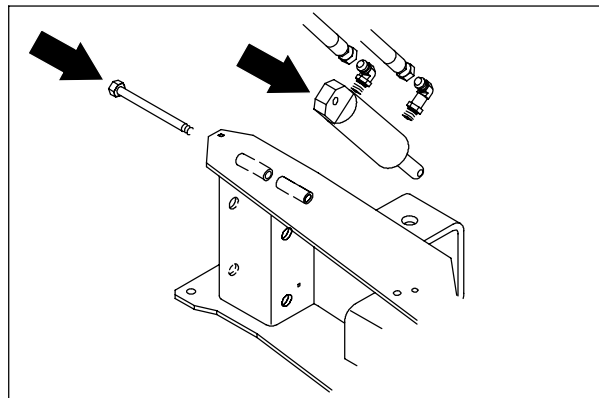
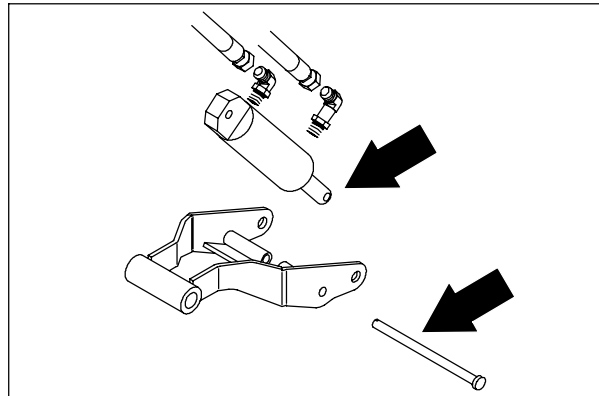

HYDRAULICS

TO REPLACE SCRUB HEAD SIDE SHIFT HYDRAULIC CYLINDER

1. Start the engine, lower and side shift the scrub head, shut off the engine.

FOR SAFETY: Before Leaving Or Servicing Machine; Stop On Level Surface, Set Parking Brake, Turn Off Machine And Remove Key.

2. Raise the rear of machine using a hoist or floor jack.

FOR SAFETY: Block machine tires before jacking machine up. Jack machine up at designated locations only. Block machine up with jack stands.

3. Remove the solution and recovery tanks from the machine. See TO REMOVE SOLUTION TANK FROM MACHINE instructions in this section.
4. Once the tanks are removed, locate the side shift cylinder on the left side of machine, behind the hydraulic control valve.

NOTE: Mark the hoses for proper re-assembly.

5. Remove and plug the hydraulic hoses connected to side shift cylinder.

NOTE: Observe hydraulic cleanliness requirements when opening hydraulic lines.

6. Remove the retaining ring that is holding the piston end of side shift cylinder to the mount pin on the machine frame.
7. Remove the cotter pin and clevis pin holding the rod end of side shift cylinder to edge scrub pivot lever.

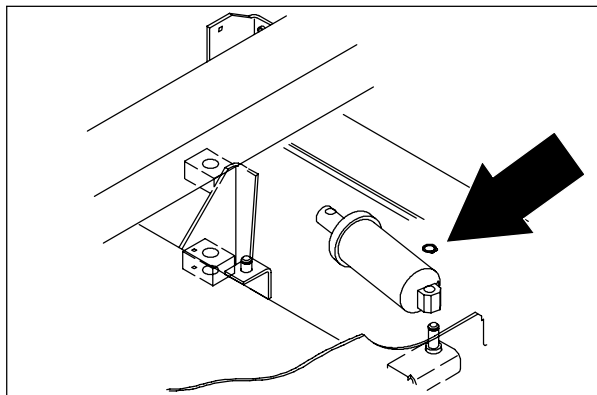
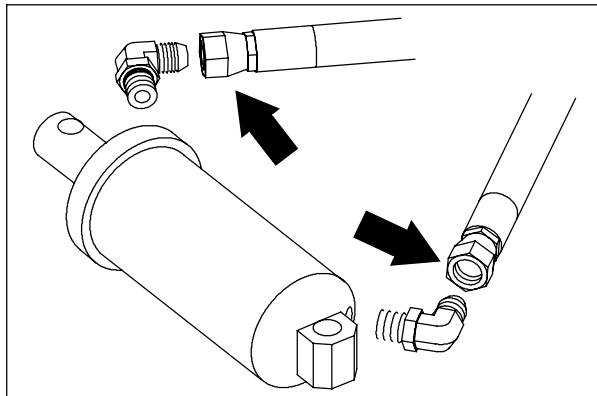
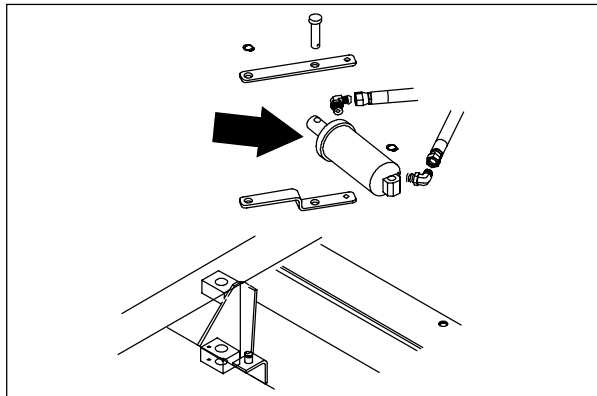
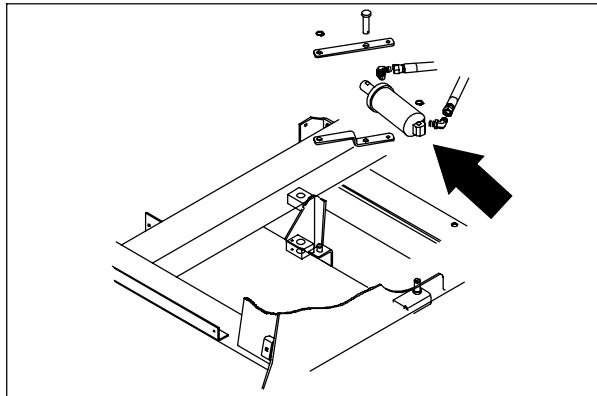

8. The side shift cylinder can now be pulled up and off the mount pin and removed from the machine.
9. Remove the hydraulic fittings and install in the new cylinder in the same orientation.
10. Position the new cylinder back in the machine. Place the hole in the piston end of the side shift cylinder on the mount pin on the machine frame. Reinstall the snap ring retainer.
11. Align the hole in the rod end of the side shift cylinder with hole in edge scrub pivot lever. Reinstall the clevis and cotter pin.
12. Reconnect the hydraulic hoses to the side shift cylinder. See the schematic in the HYDRAULICS section.
13. Reinstall the solution and recovery tanks. See TO INSTALL SOLUTION TANK instructions in this section.
14. Lower the machine. Start the engine and check for any leaks and for proper operation of the side shift function.

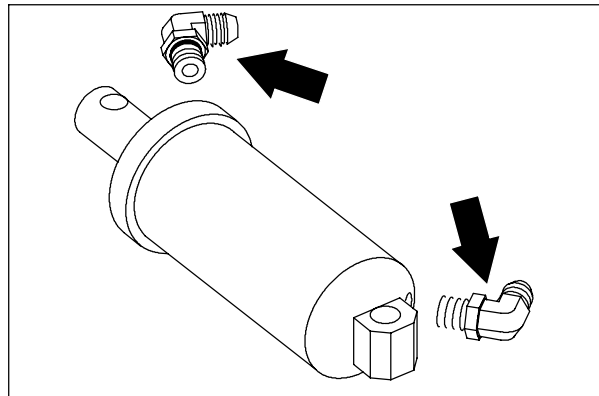
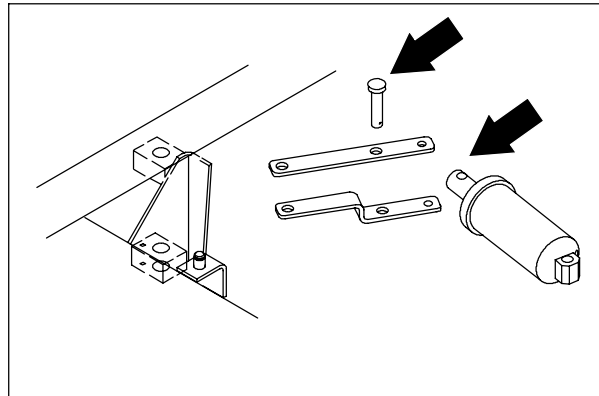

HYDRAULIC SCHEMATIC

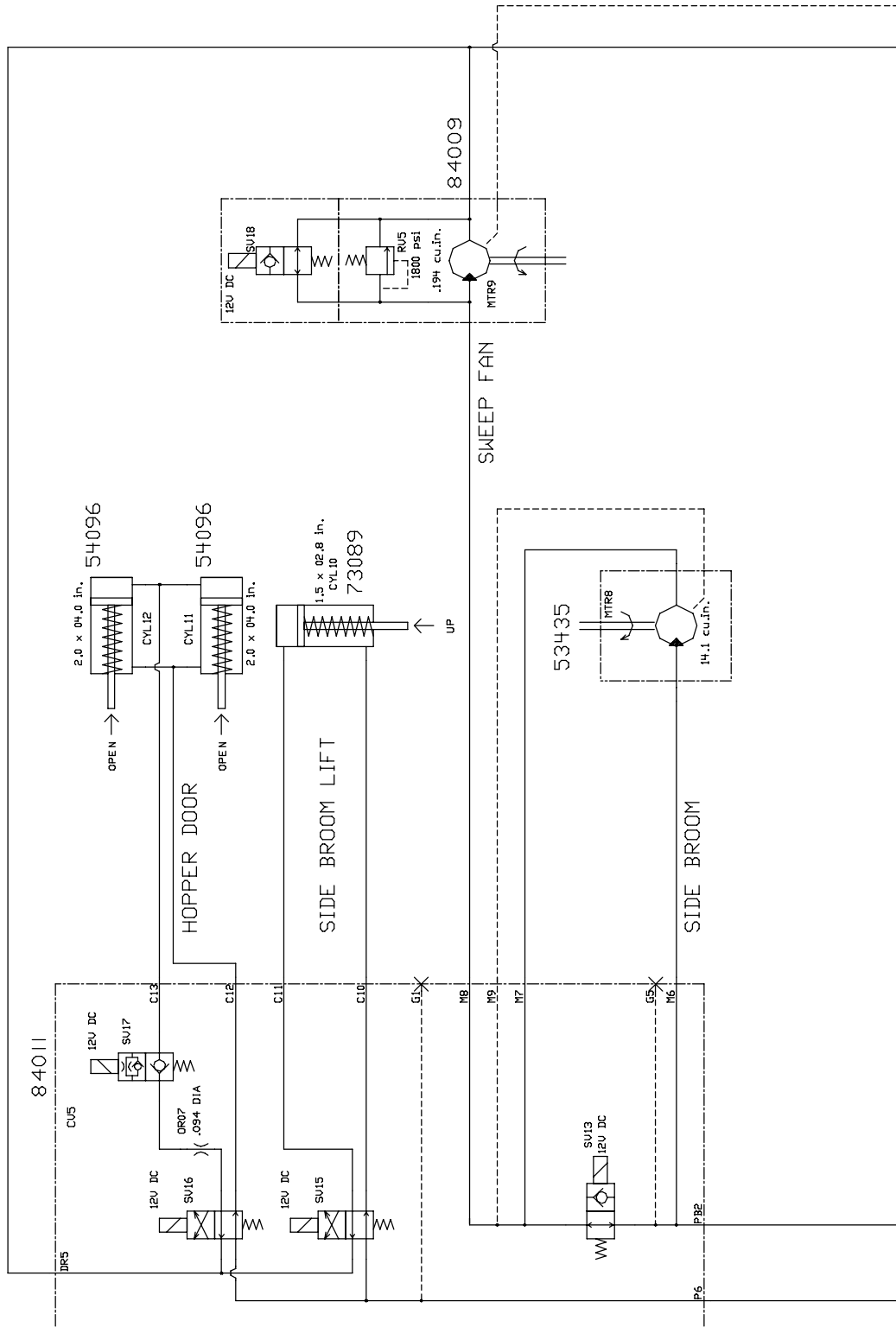

11176 - 8410, ALL

HYDRAULIC SCHEMATIC

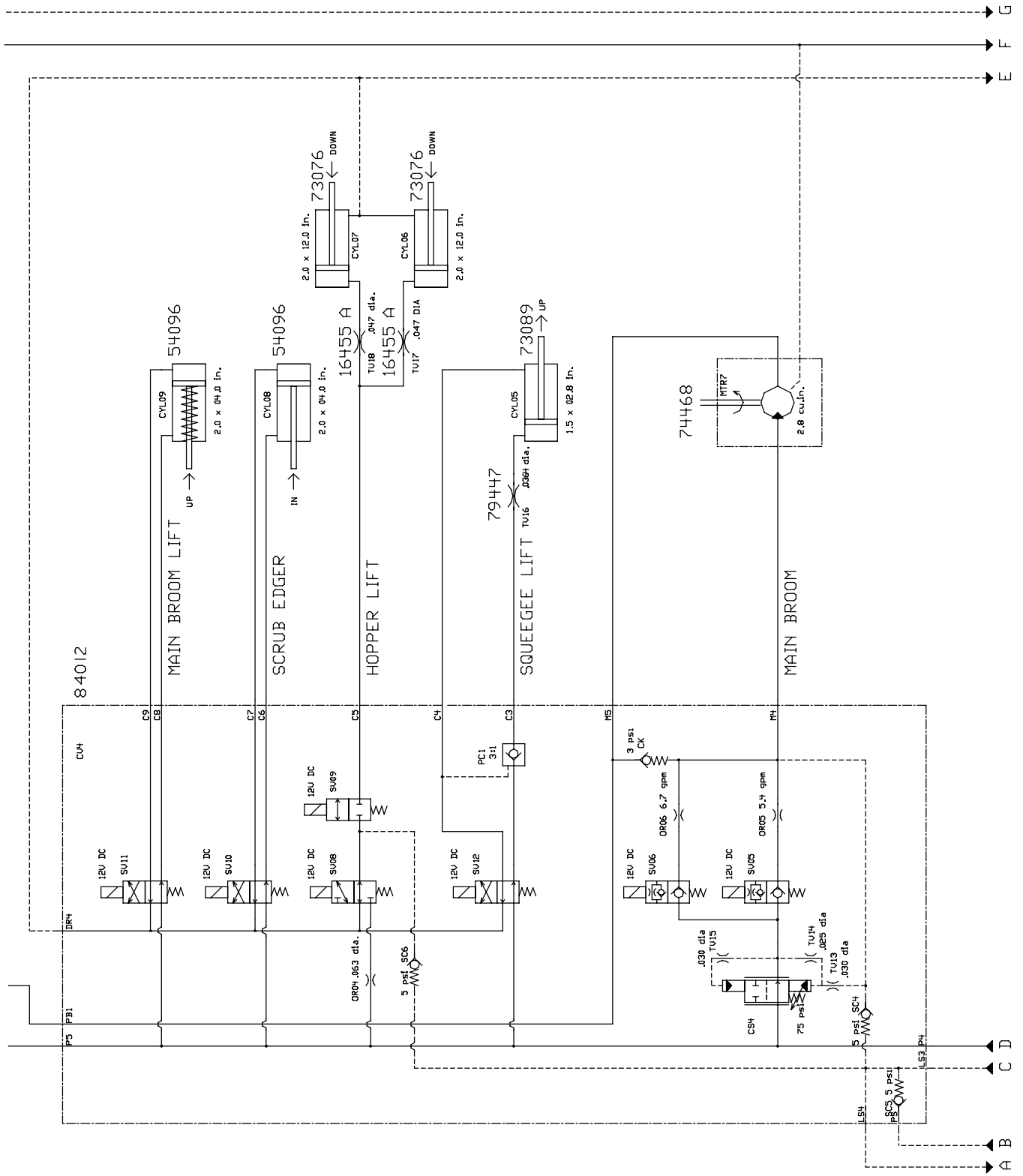

11176 - 8410, ALL

HYDRAULIC SCHEMATIC

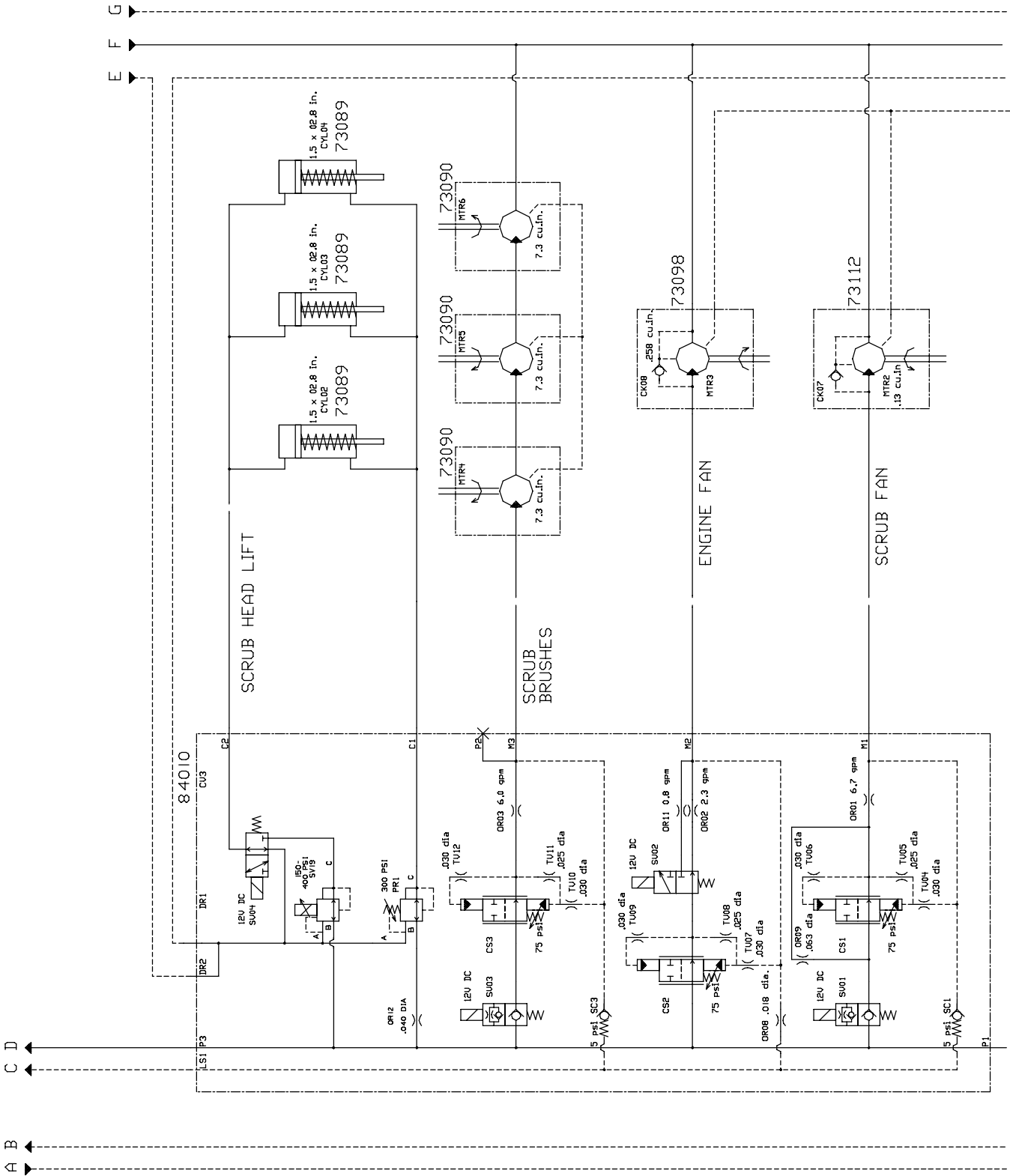

11177 - 8410, ALL

HYDRAULIC SCHEMATIC

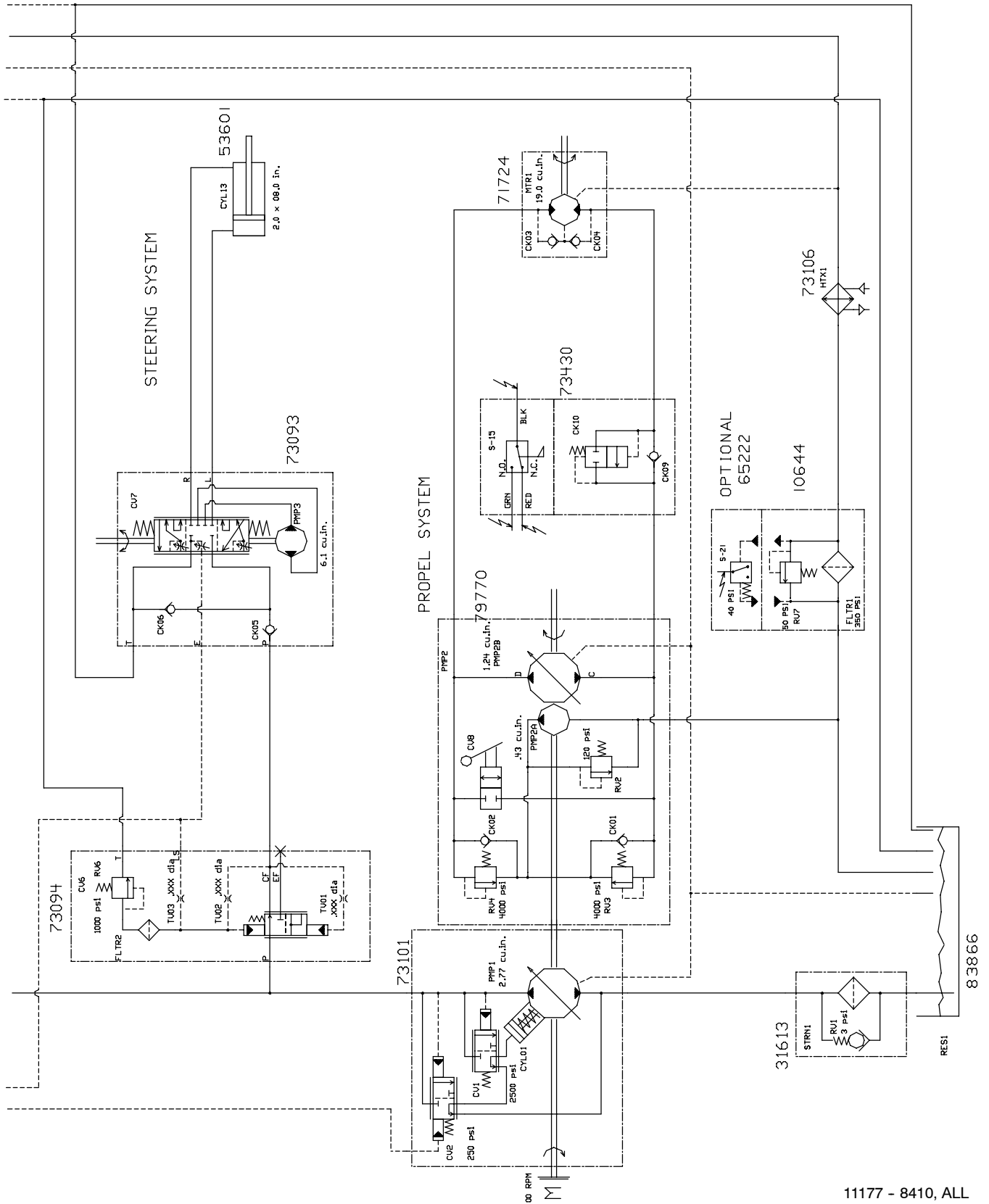

HYDRAULIC HOSE GROUP

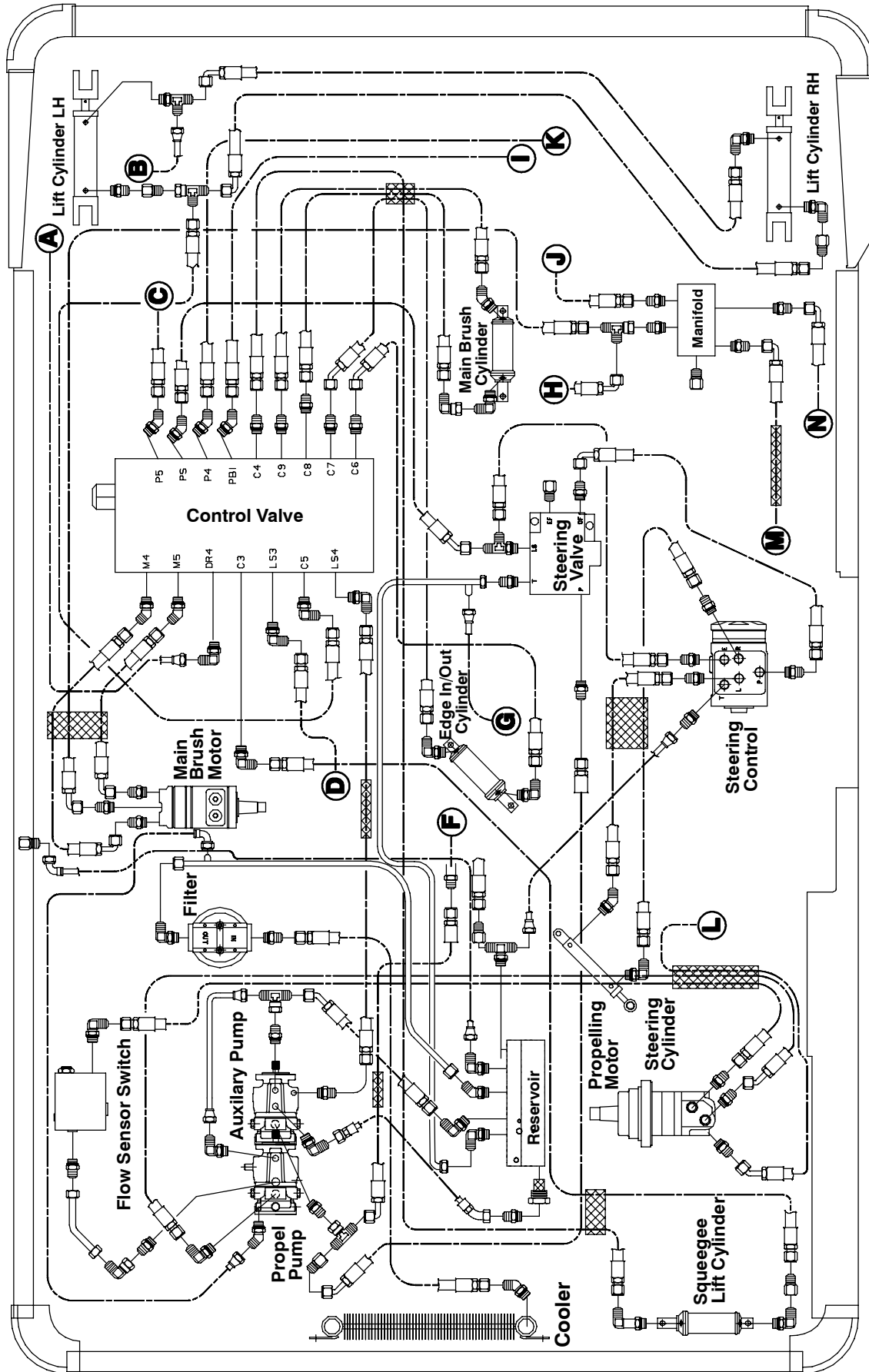

11089

HYDRAULIC HOSE GROUP

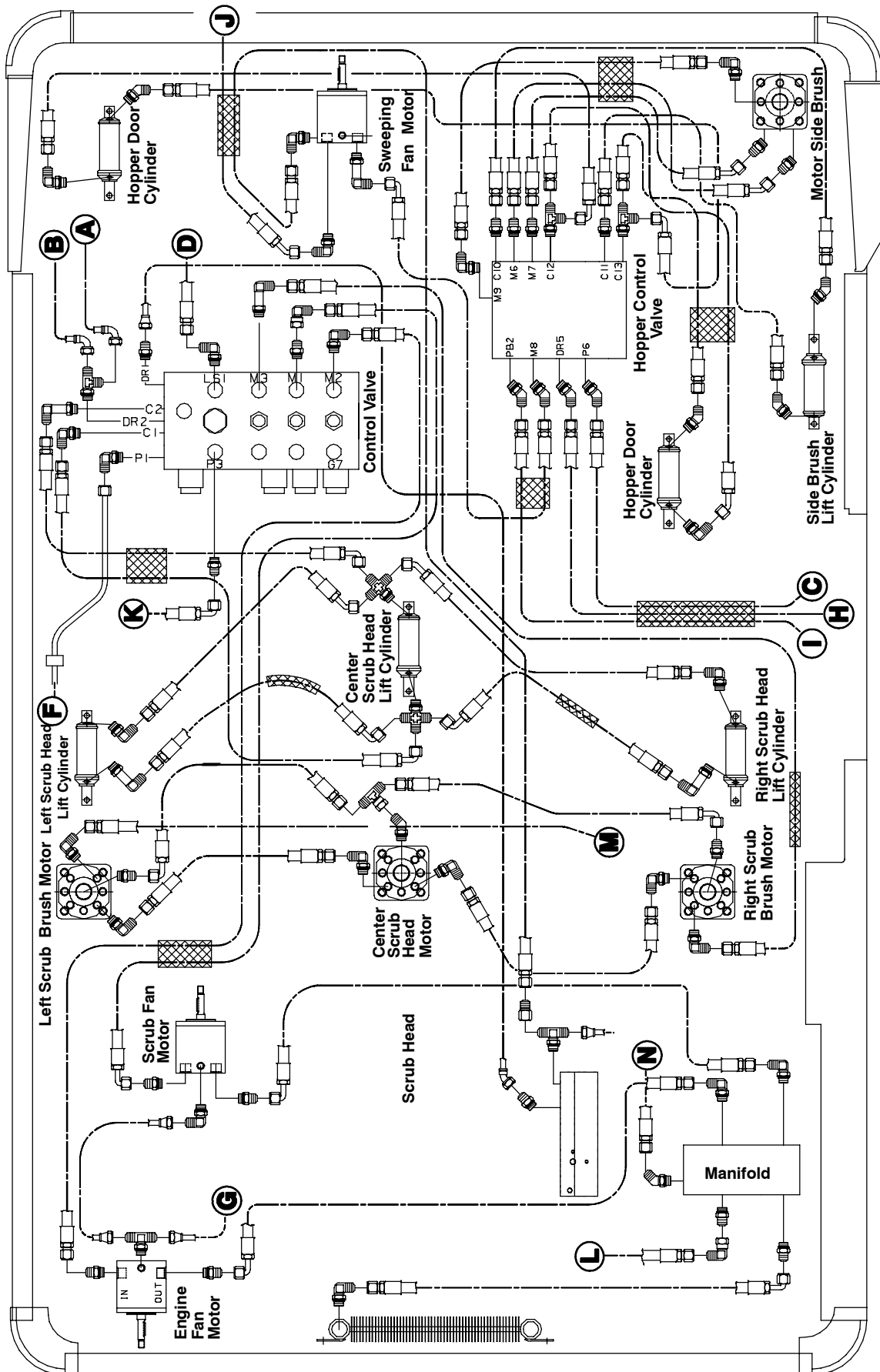

CLAMP LOCATION AND HOSE ORIENTATION

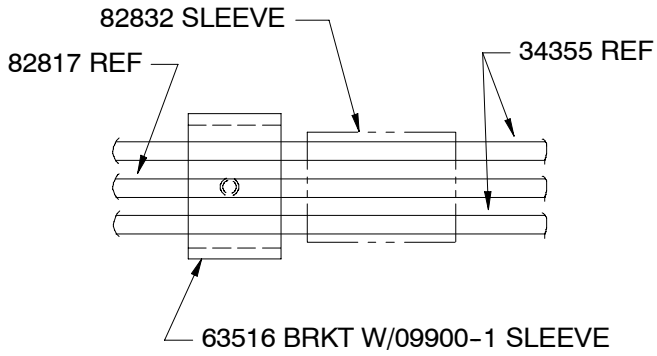

**MAIN BRUSH HOSE MOUNTING
TO BRUSH ARM**

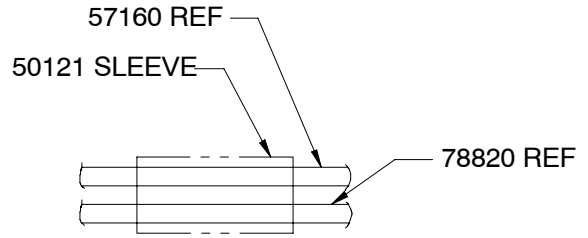

**HOSE MOUNTING TO
HOPPER RH CORNER**

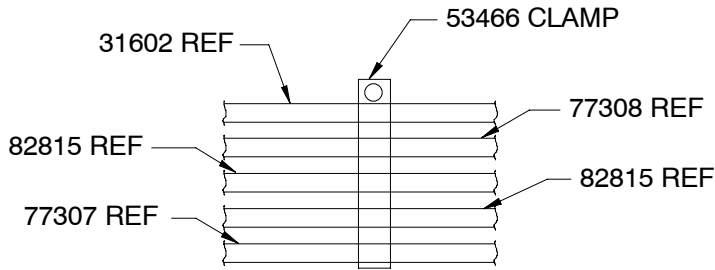

**HOSE MOUNTING TO MAIN VALVE
BRACKET ON THE FRAME**

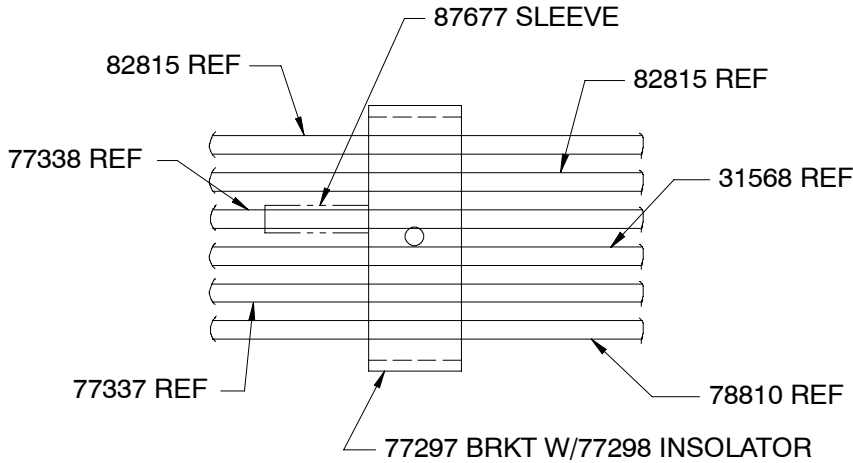

HOSE MOUNTING TO UNDERSIDE OF FRAME

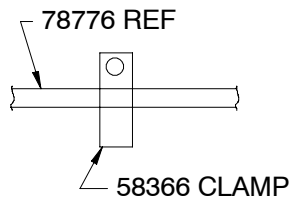

HOSE MOUNTING TO SEAT SUPPORT

CLAMP LOCATION AND HOSE ORIENTATION

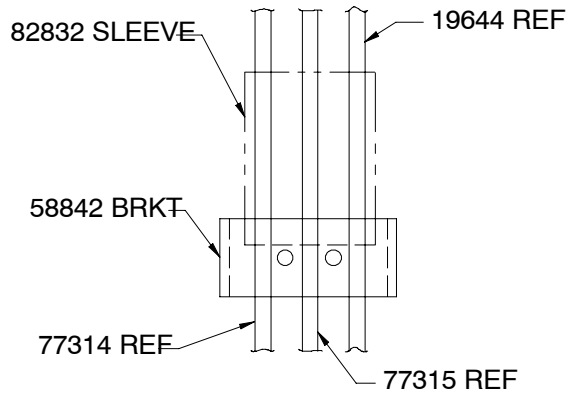

HOSE MOUNTING TO FRAME FROM MAIN DRIVE MOTOR

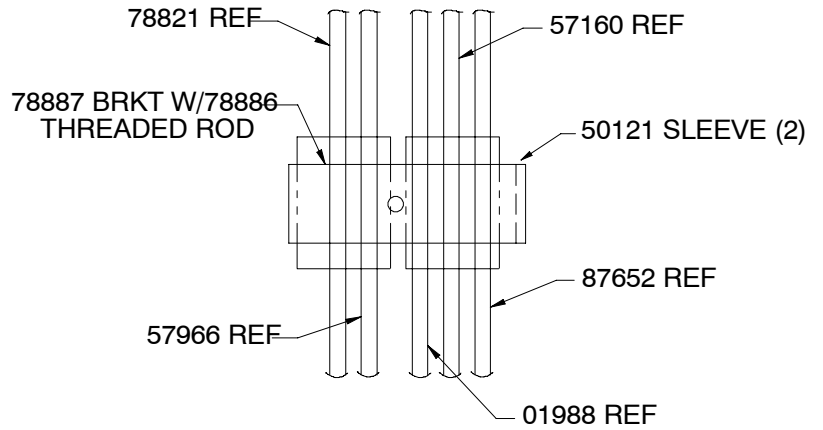

HOSE MOUNTING TO SOLUTION TANK

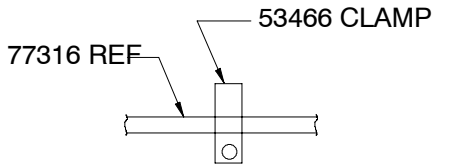

HOSE MOUNTING TO FRAME BETWEEN FILTER AND HYD TANK

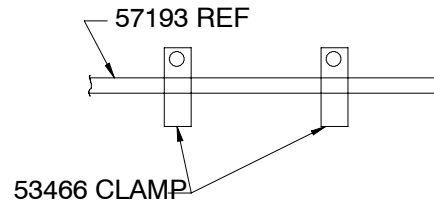

HOSE MOUNTING FROM SCRUB VALVE TO MAIN PUMP

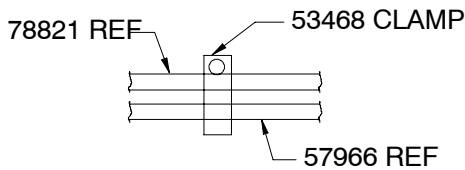

HOSE MOUNTING BY VAC FAN ON HOPPER BACKSIDE

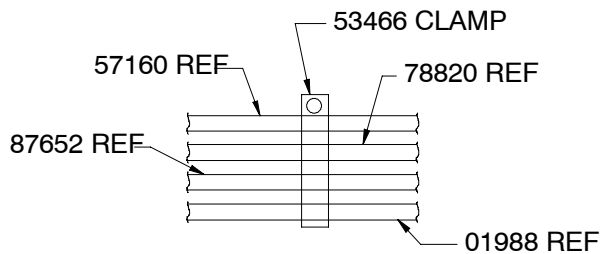

HOSE MOUNTING ON HOPPER BACKSIDE

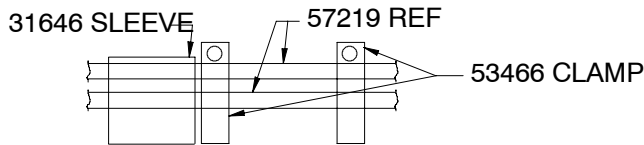

**SIDE BRUSH HOSE MOUNTING
(1) CLAMP TO HOPPER LIFT ARM
(1) CLAMP TO HOPPER SIDE**

TROUBLESHOOTING

The troubleshooting charts that follow are organized so they lead you through the circuits. They include flow charts and instructions for you as to where to insert your test instruments.

**8410 HYDRAULIC PUMP
OPERATION**

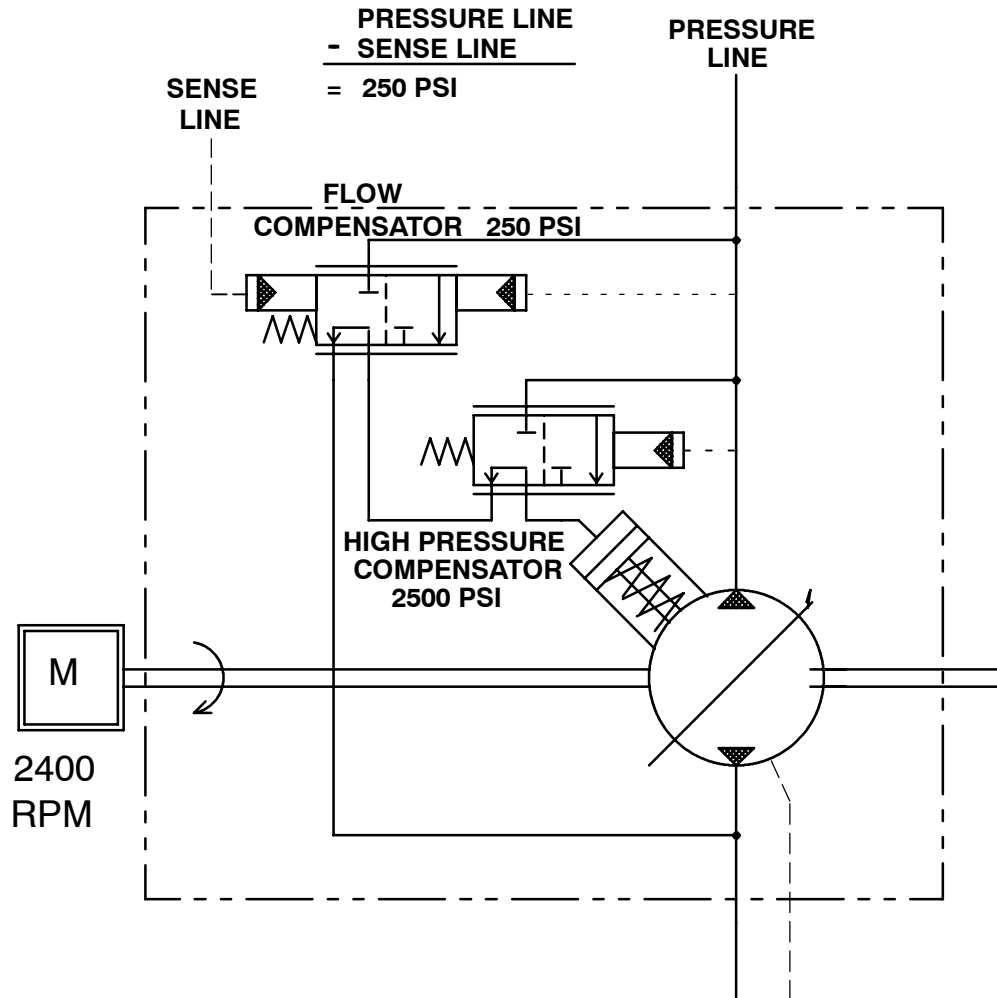

- PURPOSE:**
1. Reduce the total number of gear pumps.
 2. Reduce the amount of horsepower required.

GENERAL: The pump will deliver only the amount of oil which is demanded by the system.

OPERATION OF PISTON PUMP:

The piston pump contains nine piston assemblies which will move in and out of the piston block bores depending on the position of the cam plate. With the cam plate in the neutral position, there is no displacement of oil from the input to the output of the pump.

When the cam plate moves, the pistons will move in and out of the bores. Now the pump will pump oil. The pistons which are pulled, suck oil into the pump and then pushes the oil out the pressure port.

8410 HYDRAULIC PUMP LOW PRESSURE FLOW

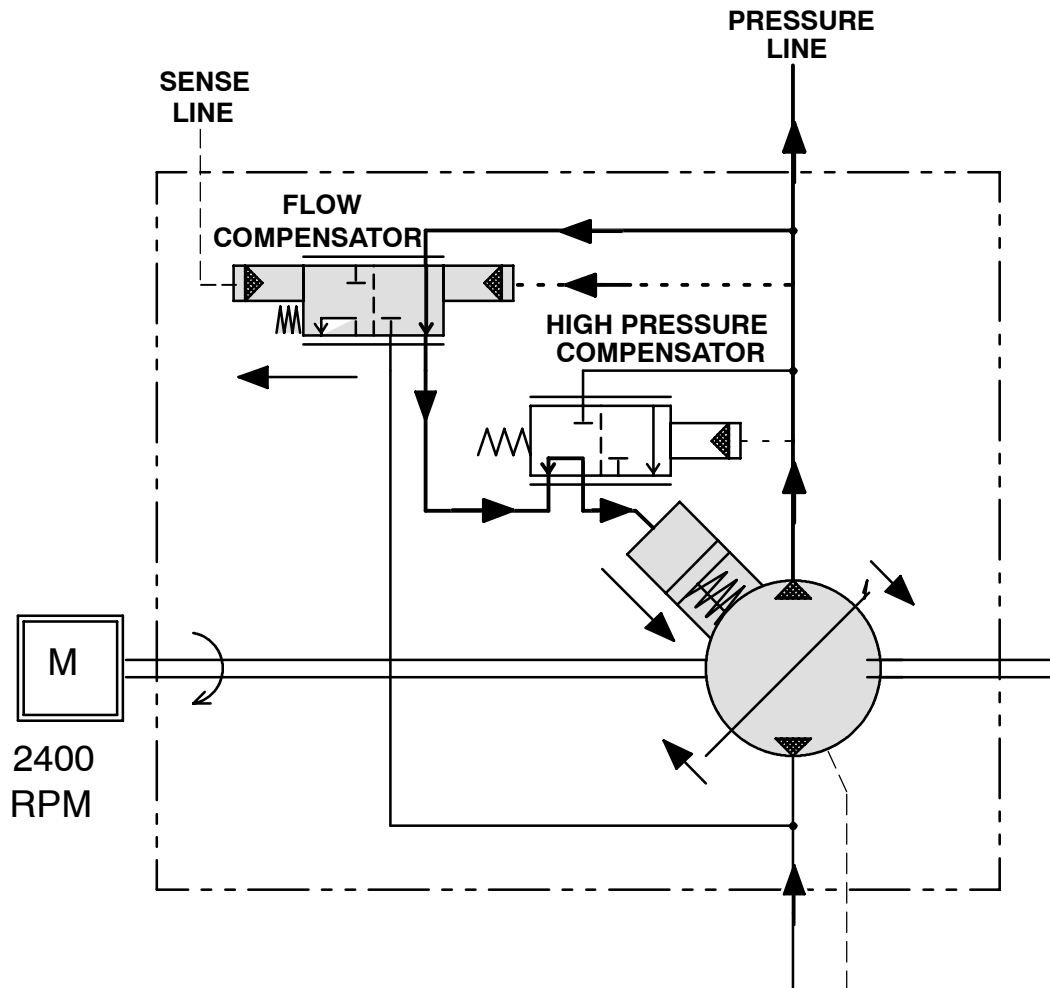

PRESSURE-FLOW LOW-PRESSURE STANDBY:

No demand for oil, so also no pressure fed back to the pump compensator through the sensor line. The pump will go into the low-pressure standby position. On the other ends of the flow compensator spool and high-pressure compensator spool, there will be a pressure of about 250 PSI (internal working of the pump). The flow spool will move and the oil will flow into the control piston. The pressure will move the cam plate back to neutral position causing the pump to destroke. Pump will only pump enough oil to make up for internal oil leakage and maintain 250 PSI in the pressure line.

8410 HYDRAULIC PUMP
INCREASE FLOW DEMAND

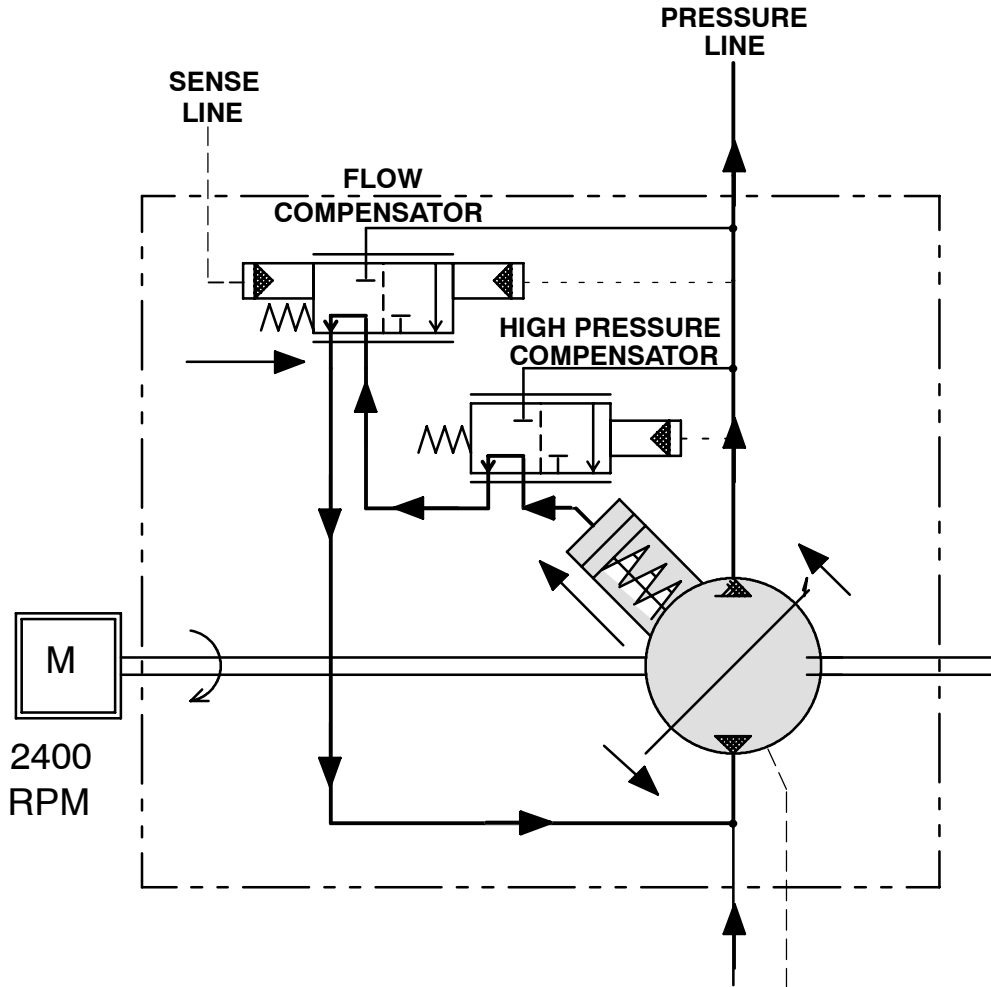

PRESSURE-FLOW INCREASED FLOW DEMAND:

Demand for increased oil flow. The flow spool moves because of the pressure on the sensor line. Now the oil will flow from the control piston via the spool to the drain suction port. The cam plate will move to a greater angle and the pump will provide more oil until the demand of oil is met.

PRESSURE-FLOW LOAD SENSING WORKING PRESSURE:

When there is a demand of oil, this is controlled by the difference in pressure applied to the ends of the flow compensating spool. When the pressure in the sensor line increases or decreases, the spool will move up and down. This means that the control piston for the cam plate will be filled with oil or discharged. This will move the cam plate to another position. When moving the cam plate, the nine piston assemblies will move in and out of the bores and provide more or less oil to the output port.

8410 HYDRAULIC PUMP HIGH PRESSURE

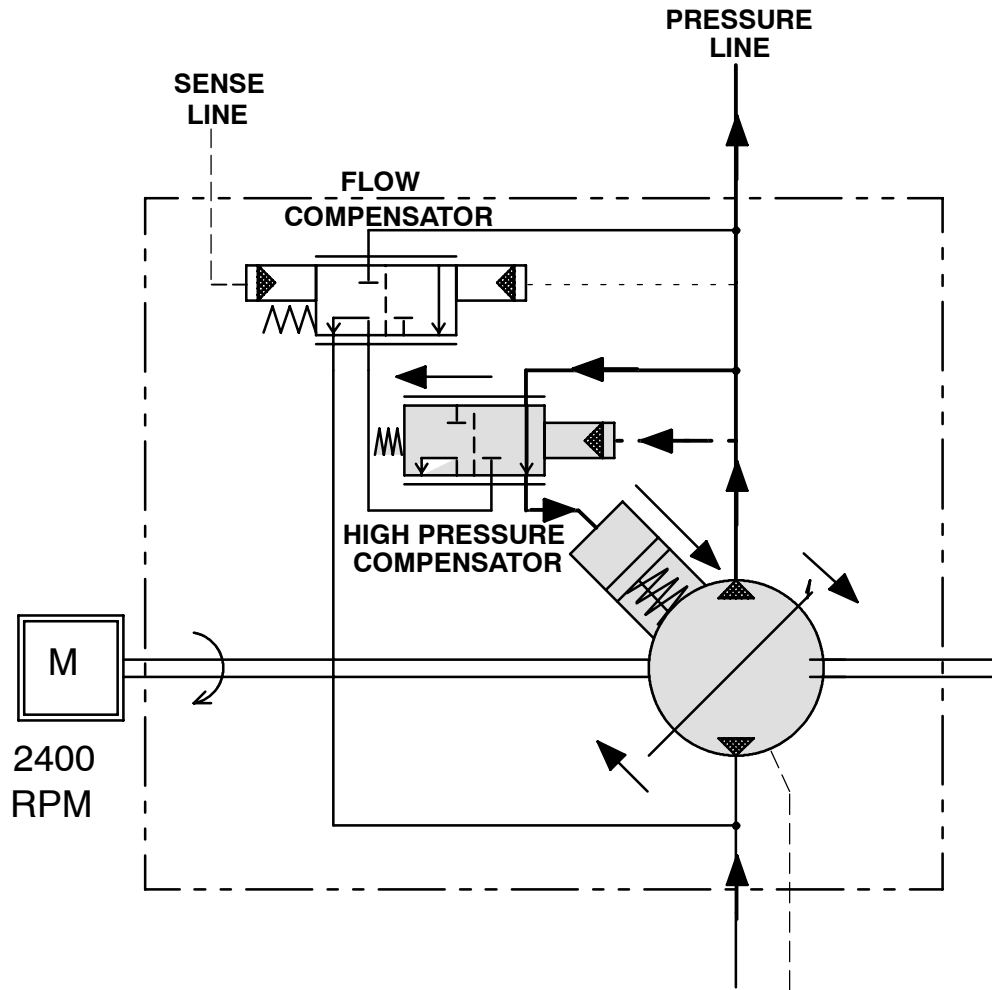

HIGH-PRESSURE STANDBY:

When the hydraulic system is overloaded, the pump will go into the high-pressure standby position. The pressure on both ends of the flow spool will be equal and does not function in this case. Now the high-pressure spool is working. The pressure from the pump will move the spool and will enter oil inside the control piston which will move the cam plate in the position compared to the normal working condition. This means the amount of oil is reduced.

ENGINE FAN CIRCUIT (HIGH SPEED)

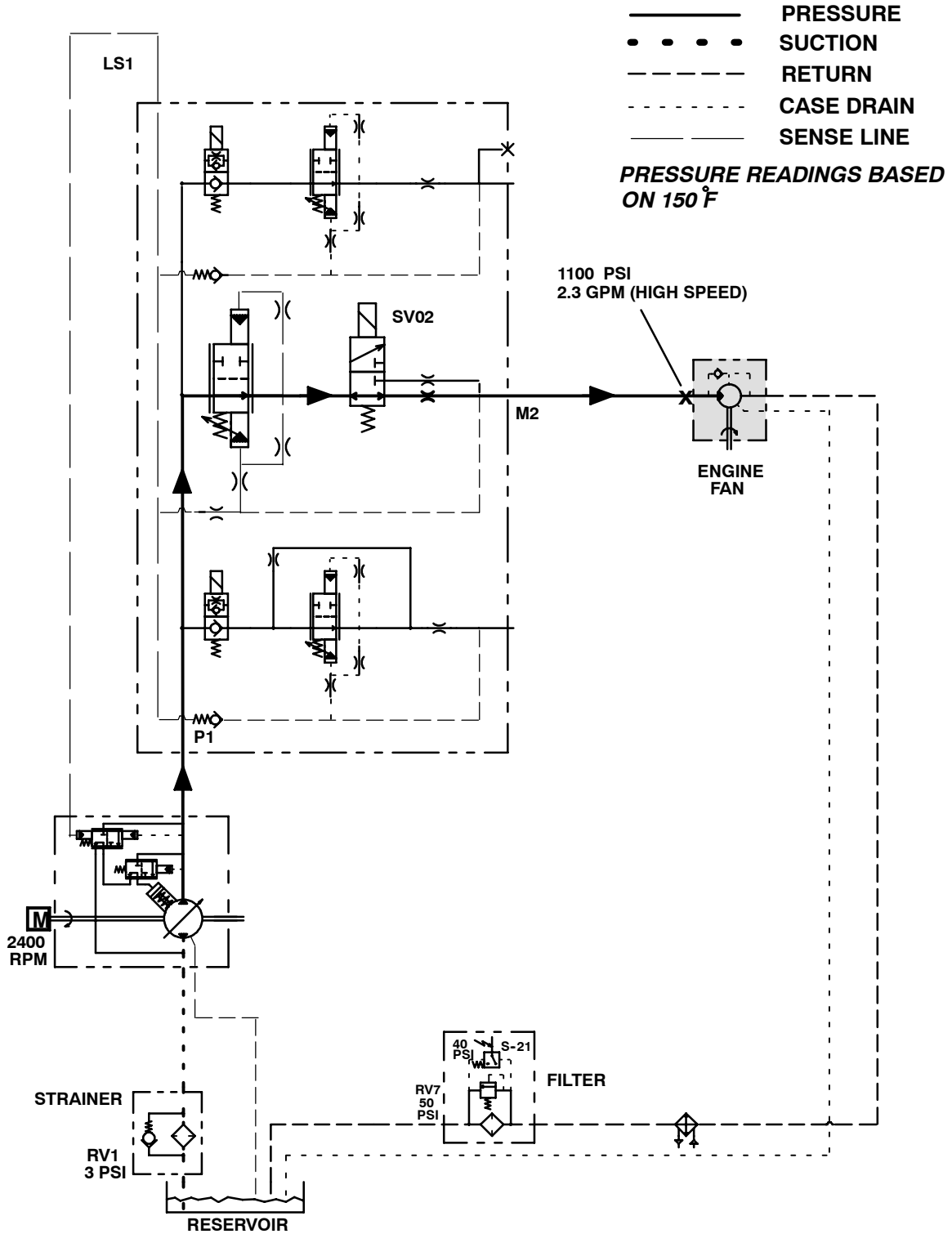

ENGINE FAN CIRCUIT (IDLE SPEED)

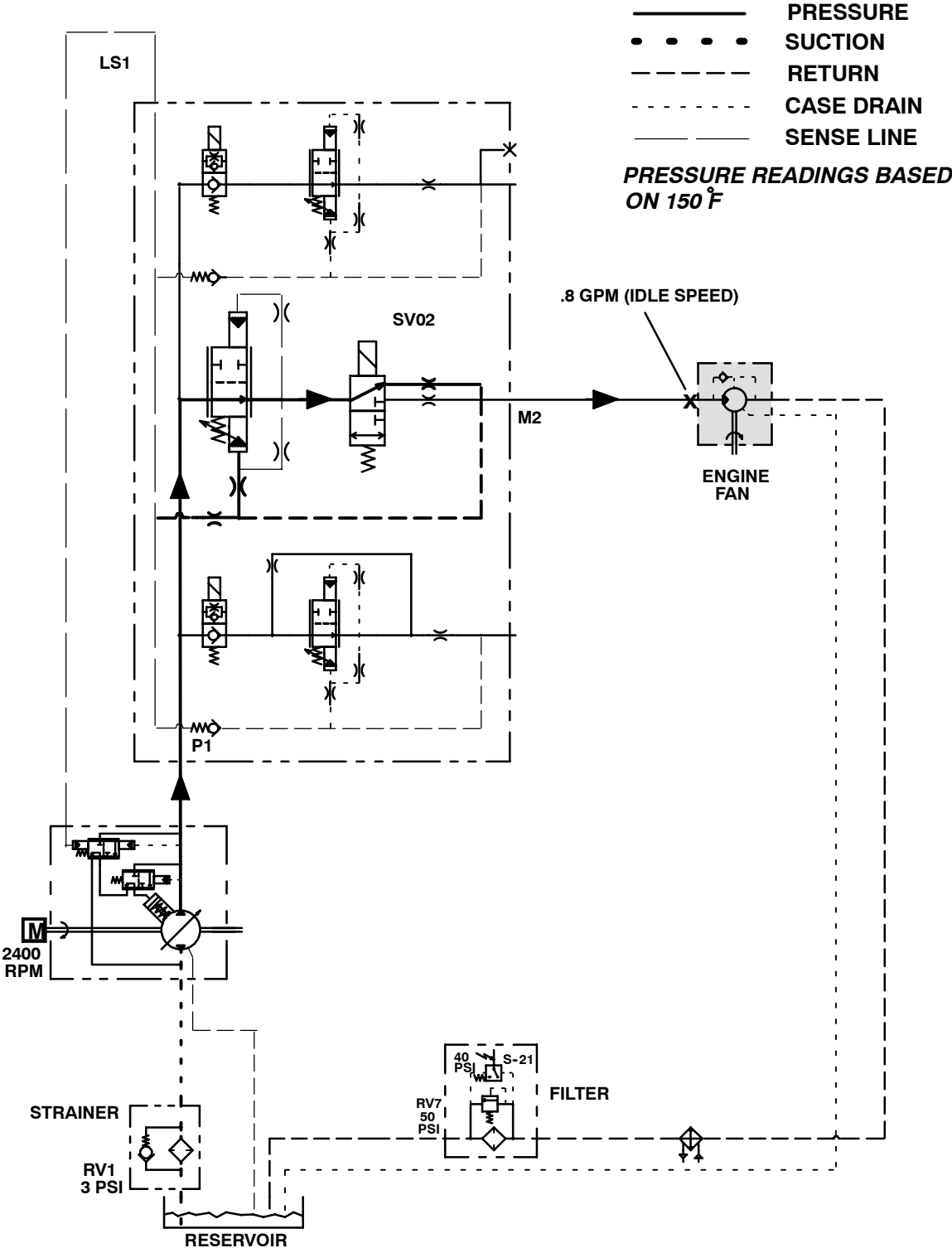

ENGINE FAN DOES NOT RUN

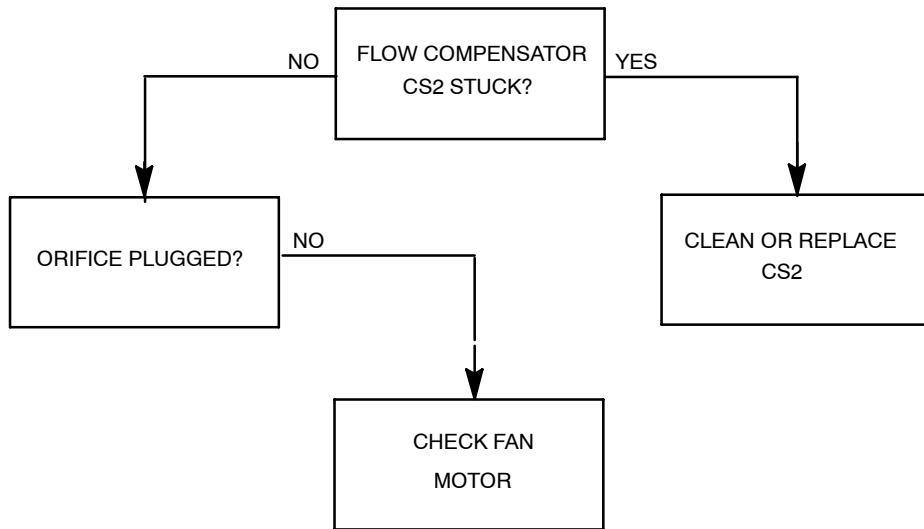

ENGINE FAN ALWAYS RUNS FAST

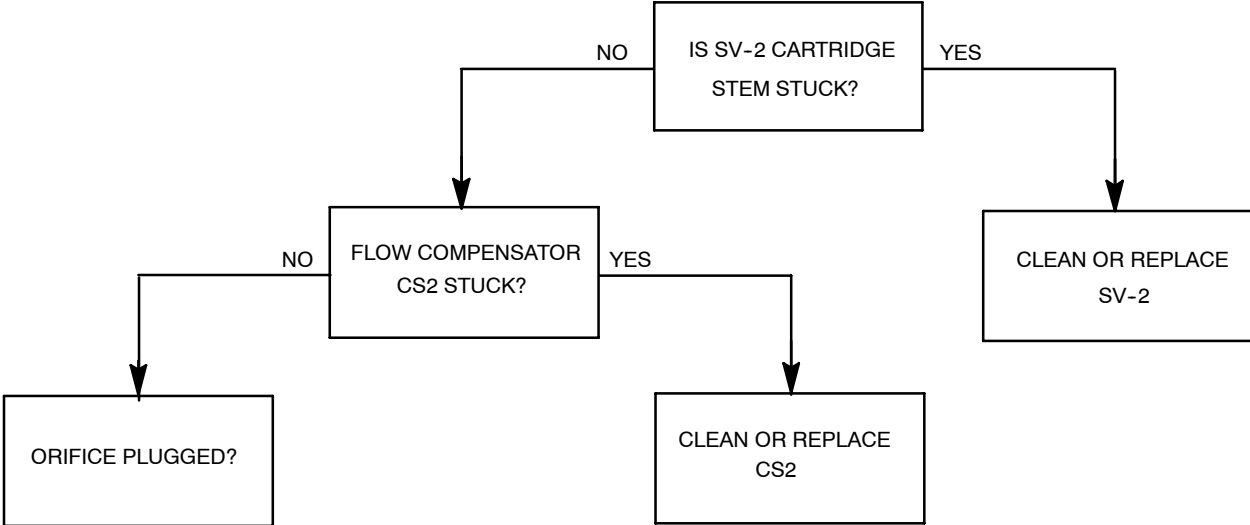

ENGINE FAN ALWAYS RUNS SLOW

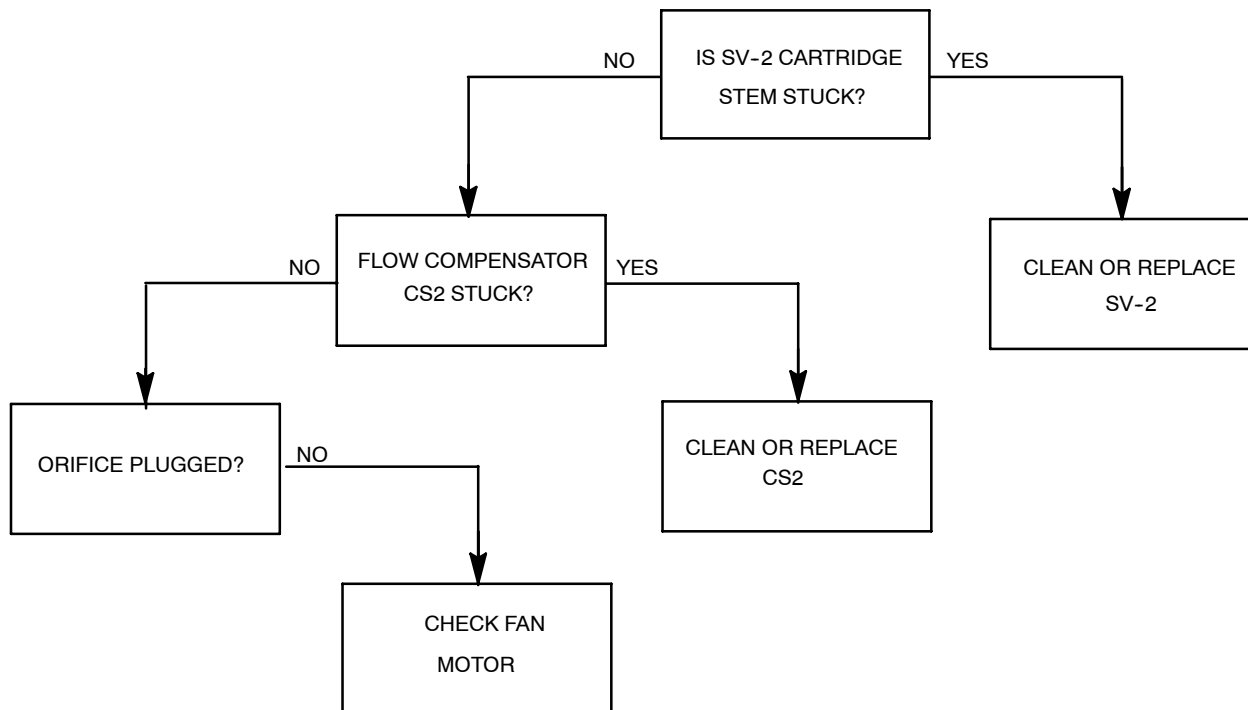

SCRUB FAN CIRCUIT

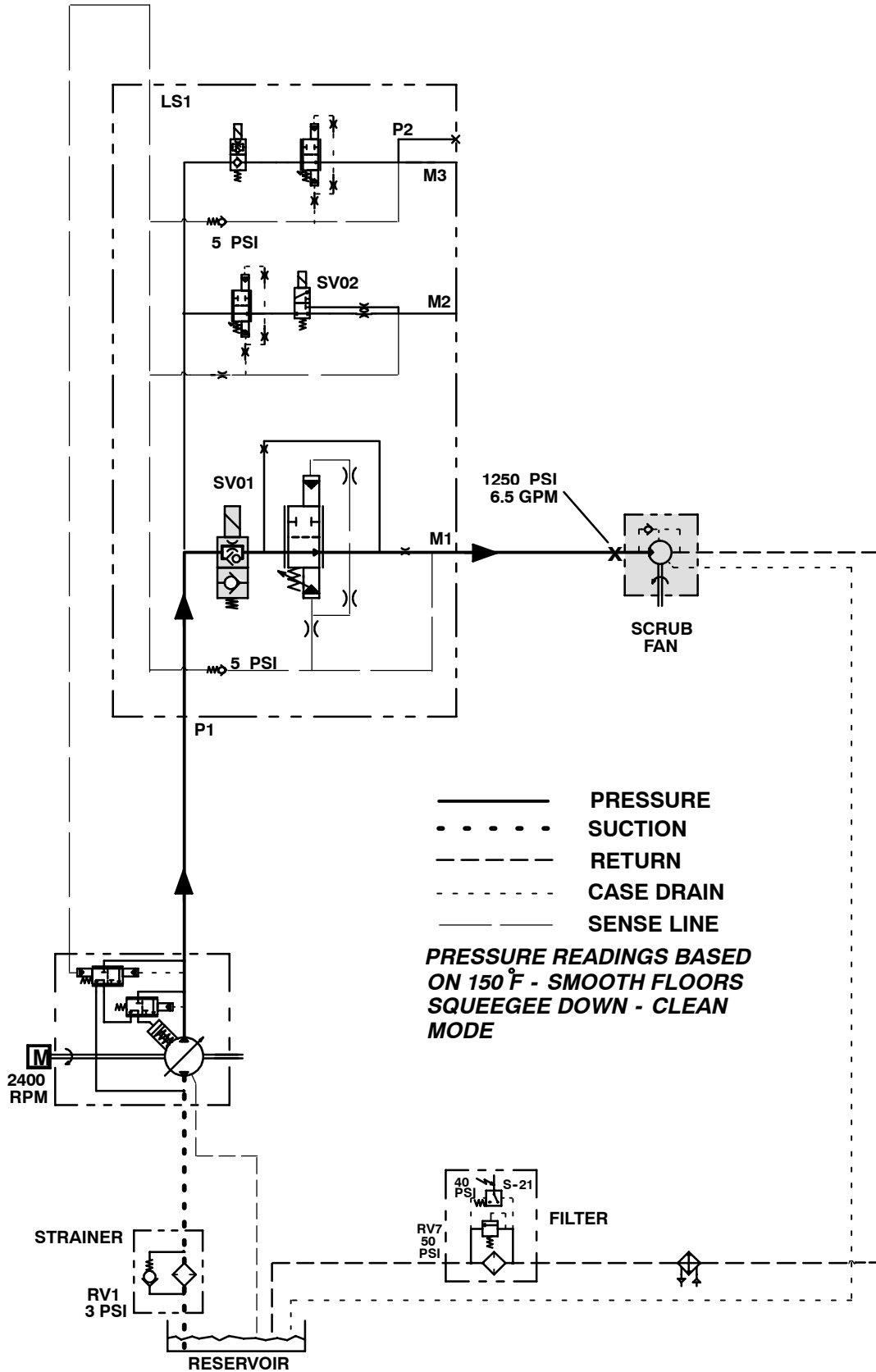

SCRUB FAN DOES NOT TURN OFF

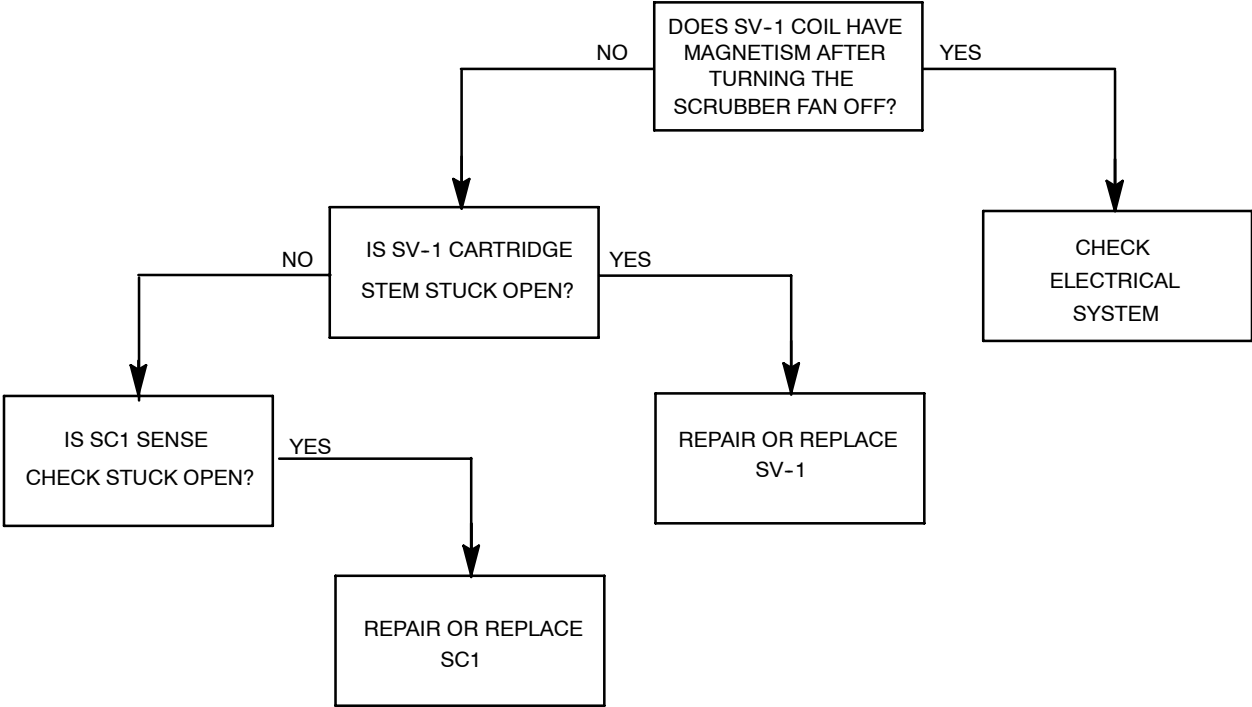

SCRUB FAN DOES NOT TURN ON

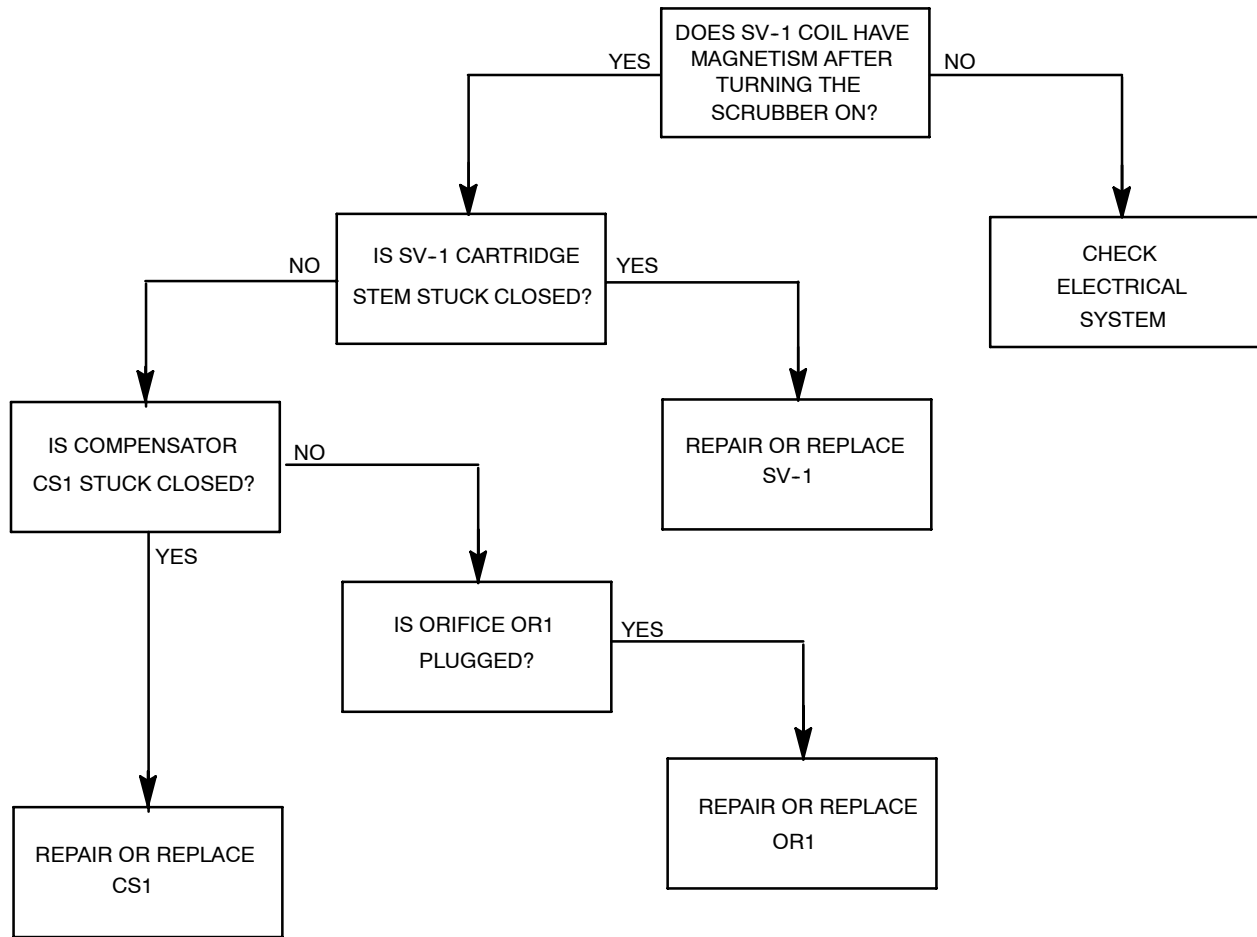

HOPPER DOOR CLOSE CIRCUIT

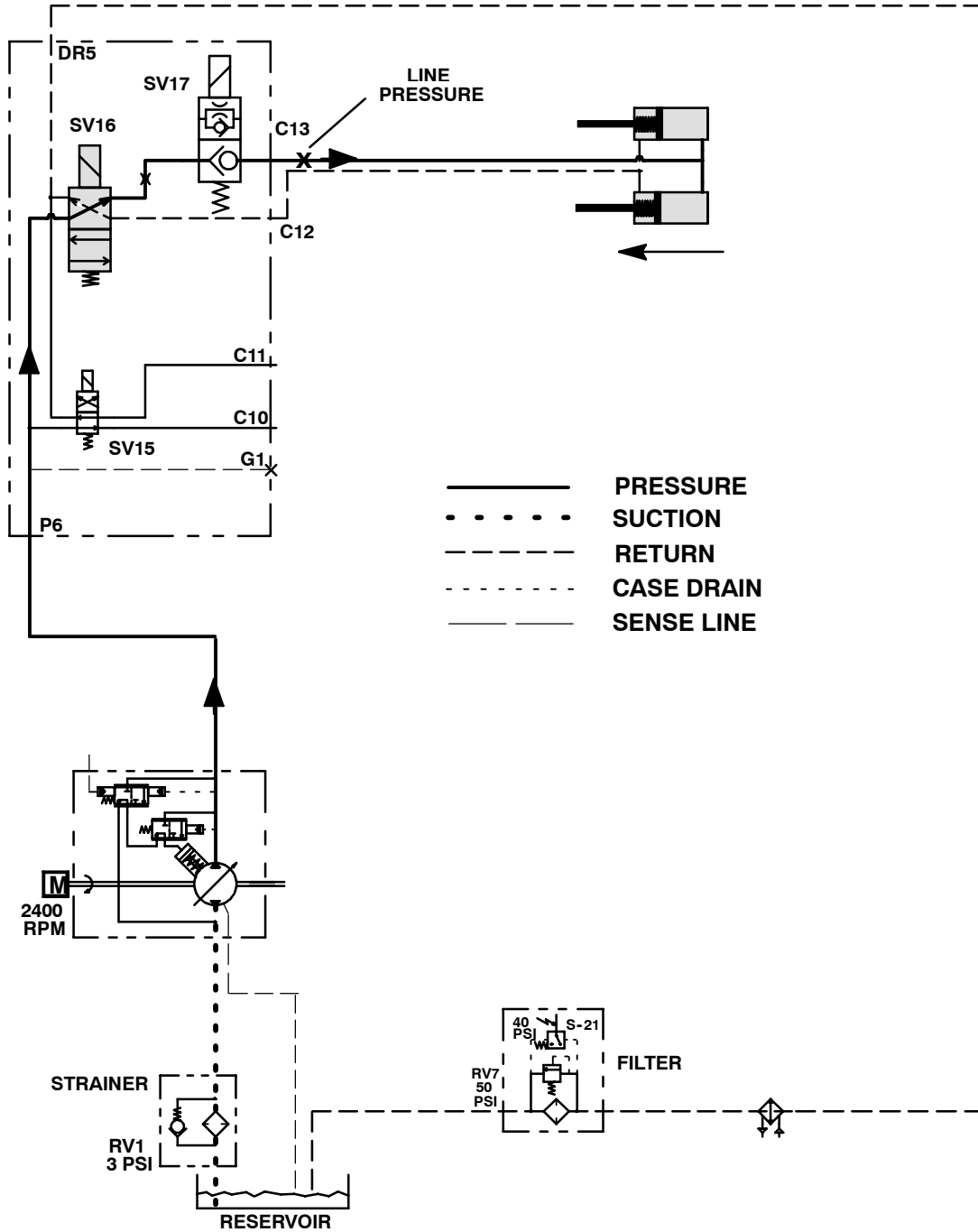

HOPPER DOOR DOES NOT OPEN

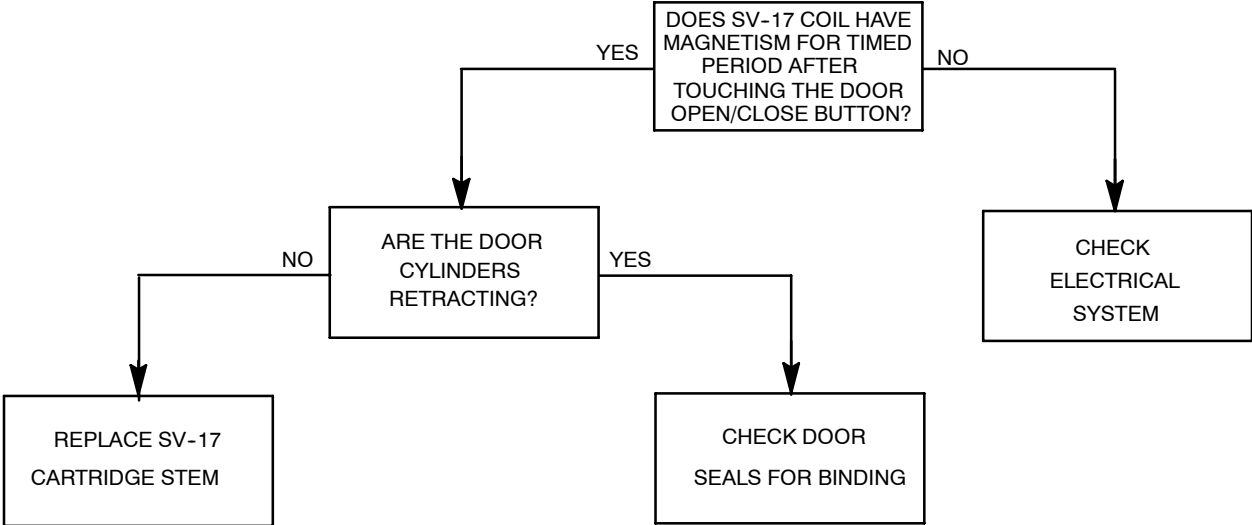

HOPPER DOOR DOES NOT CLOSE

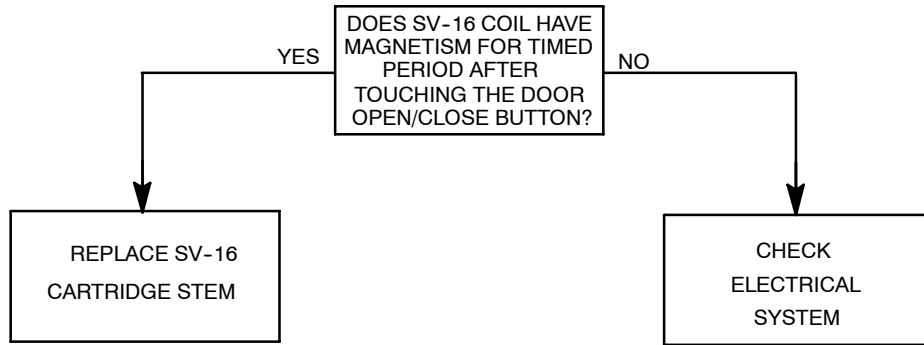

HOPPER DOOR DOES NOT STAY CLOSED

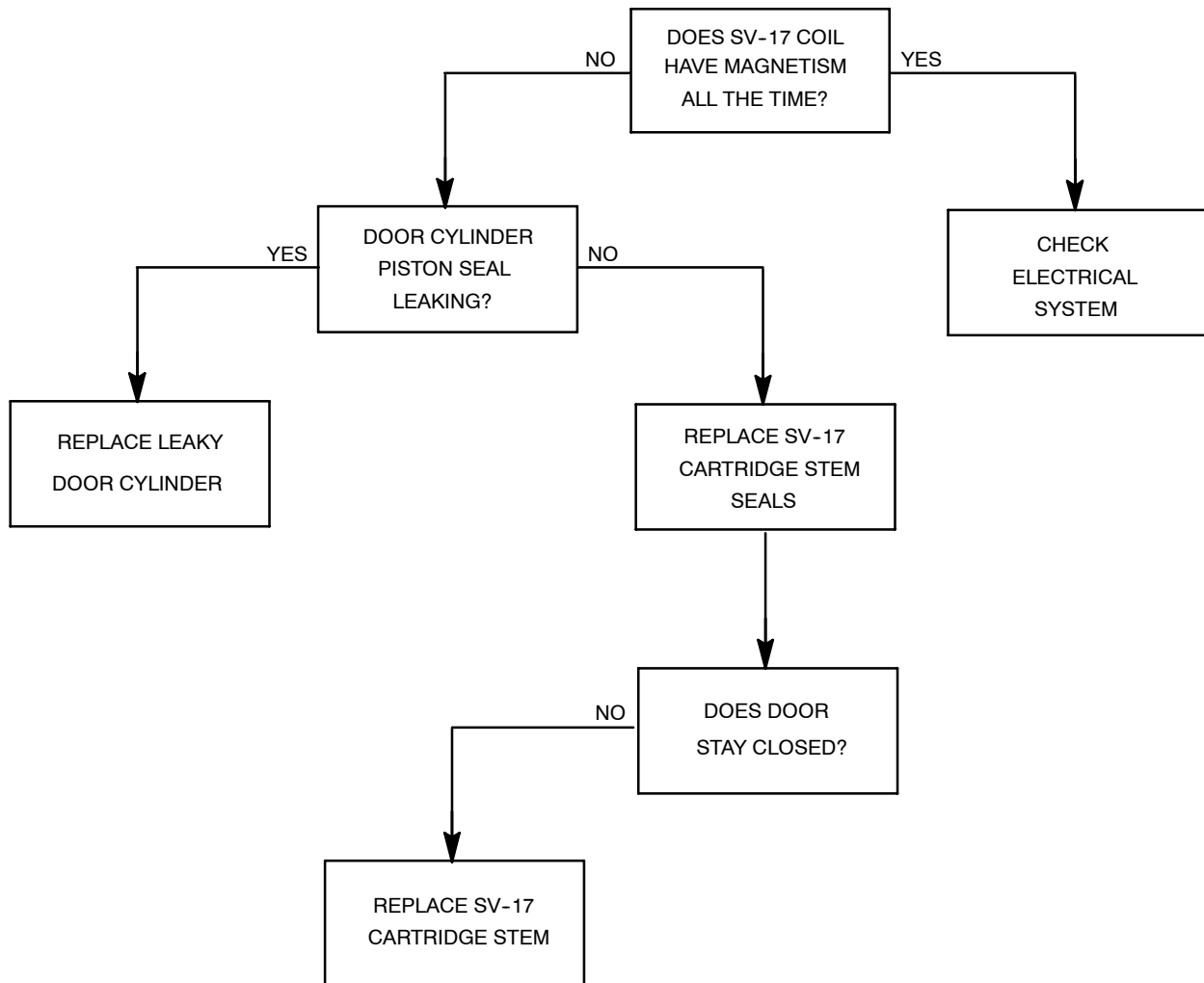

HOPPER LIFT CIRCUIT

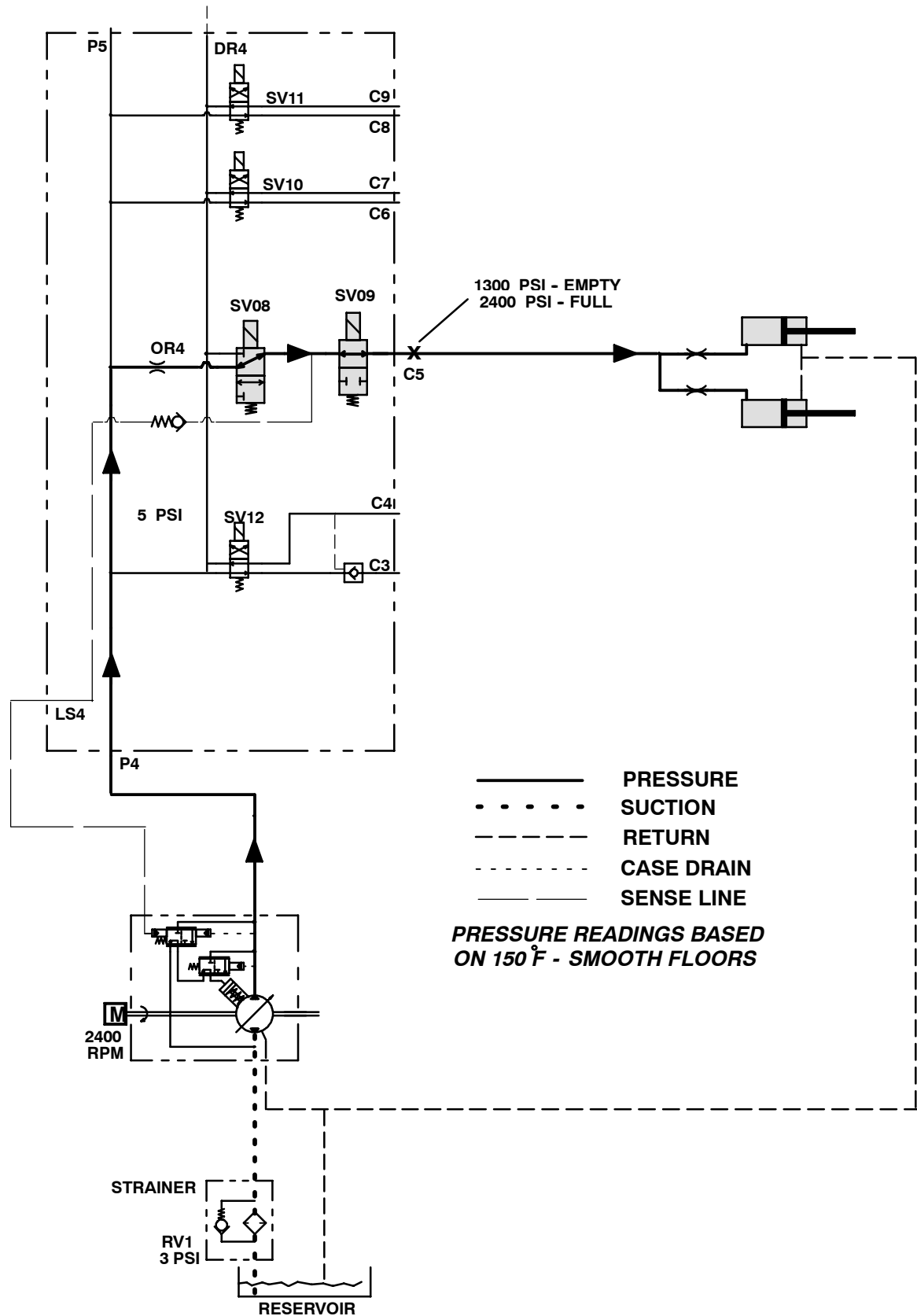

HOPPER DOES NOT RAISE

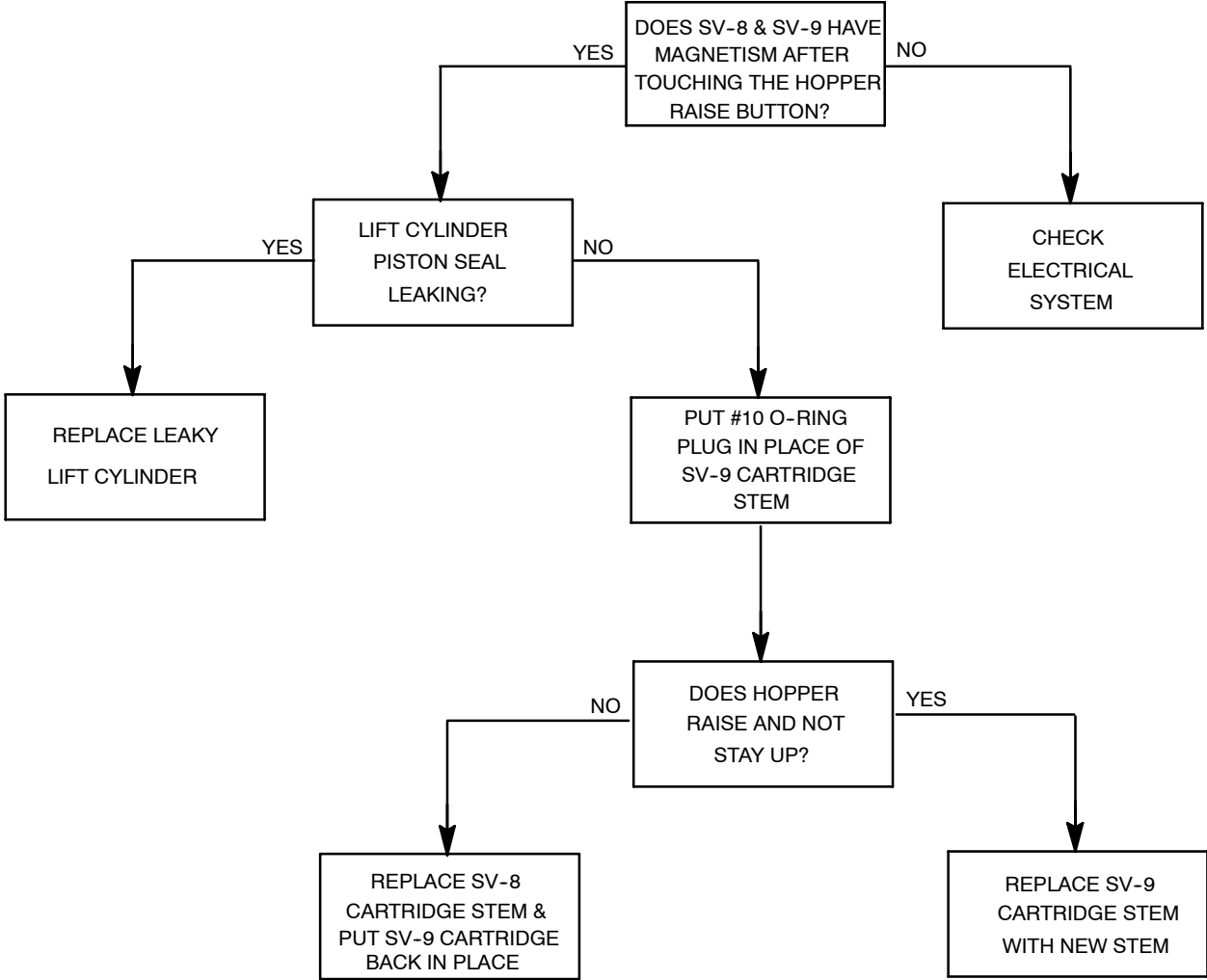

HOPPER DRIFTS DOWN TOO QUICKLY

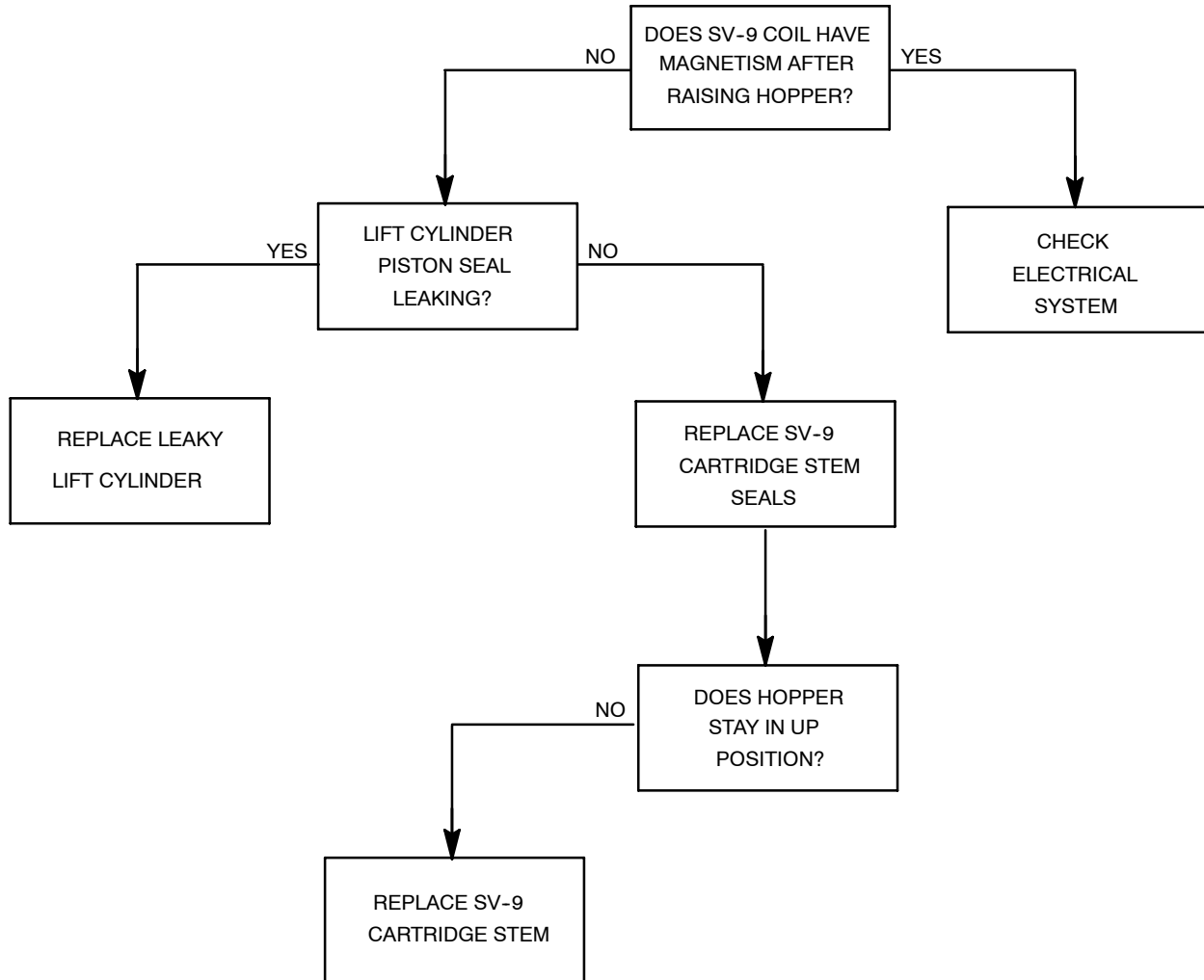

HOPPER LOWER CIRCUIT

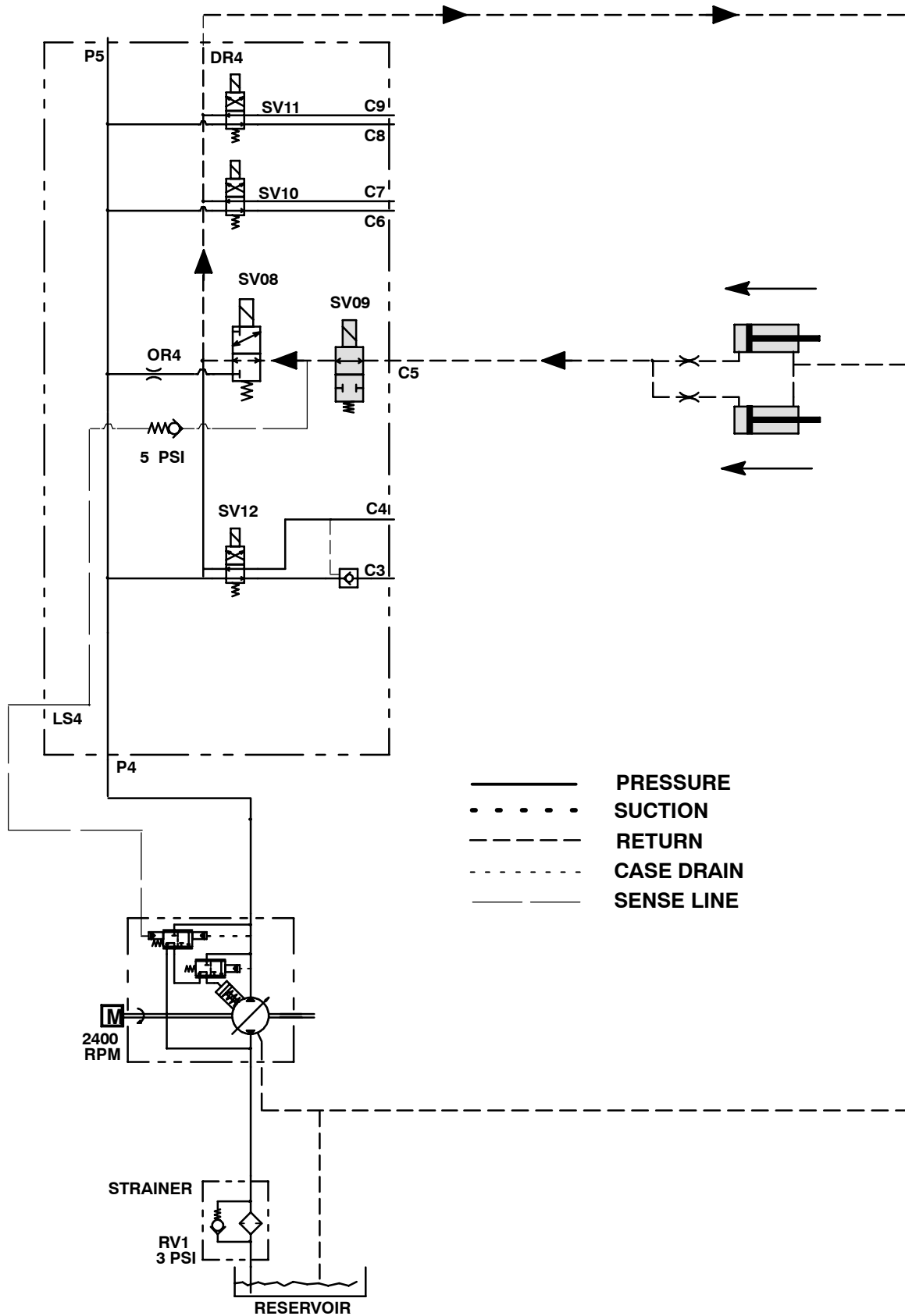

HOPPER DOES NOT LOWER

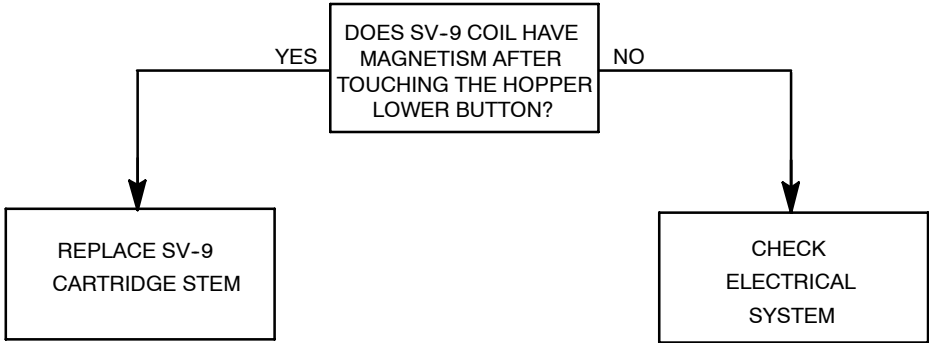

MAIN BRUSH CIRCUIT - SPD 1
(MAIN BRUSH DOWN AND ON, VAC FAN ON)

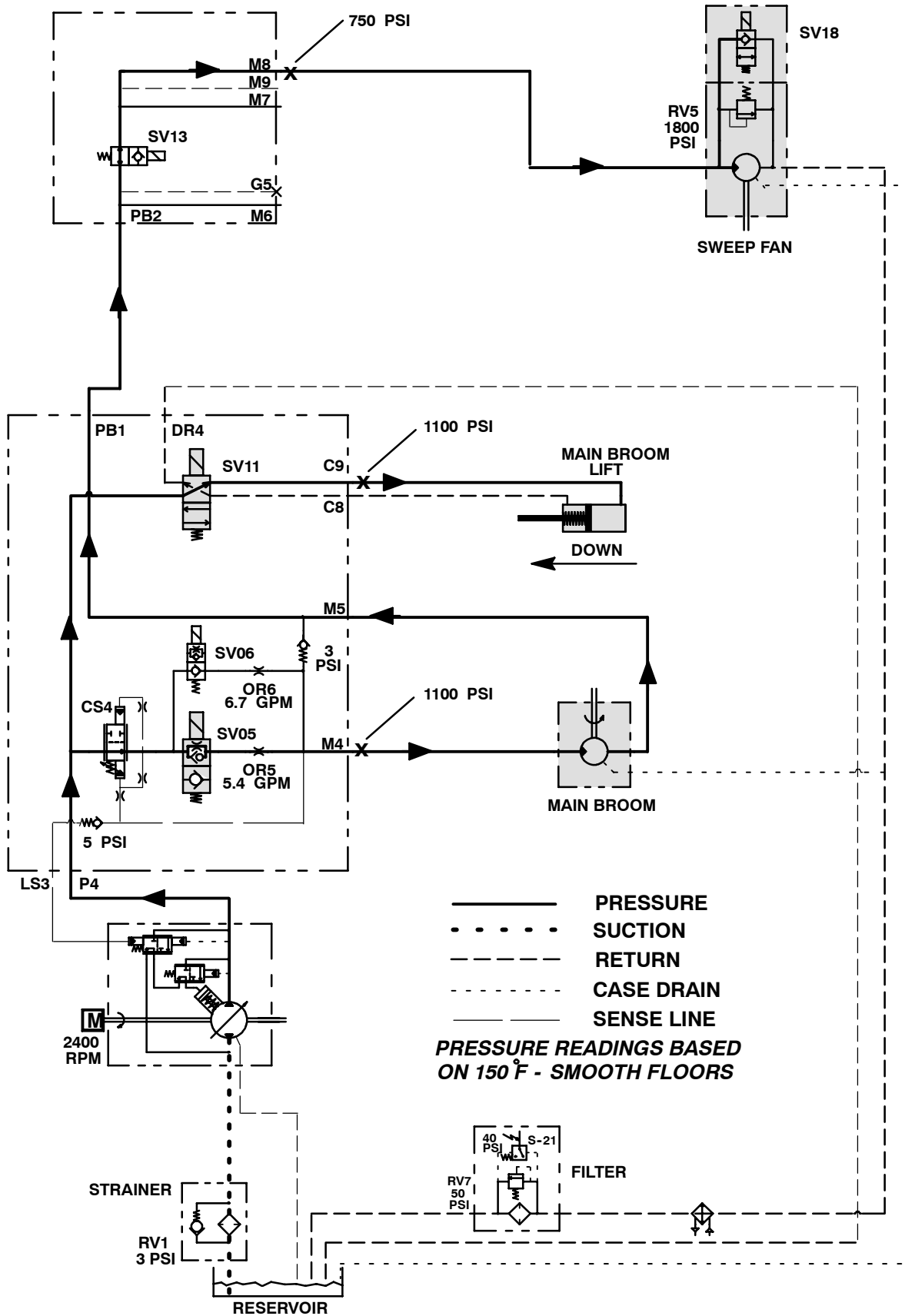

MAIN BRUSH CIRCUIT - SPD 2
 (MAIN BRUSH DOWN AND ON, VAC FAN ON)

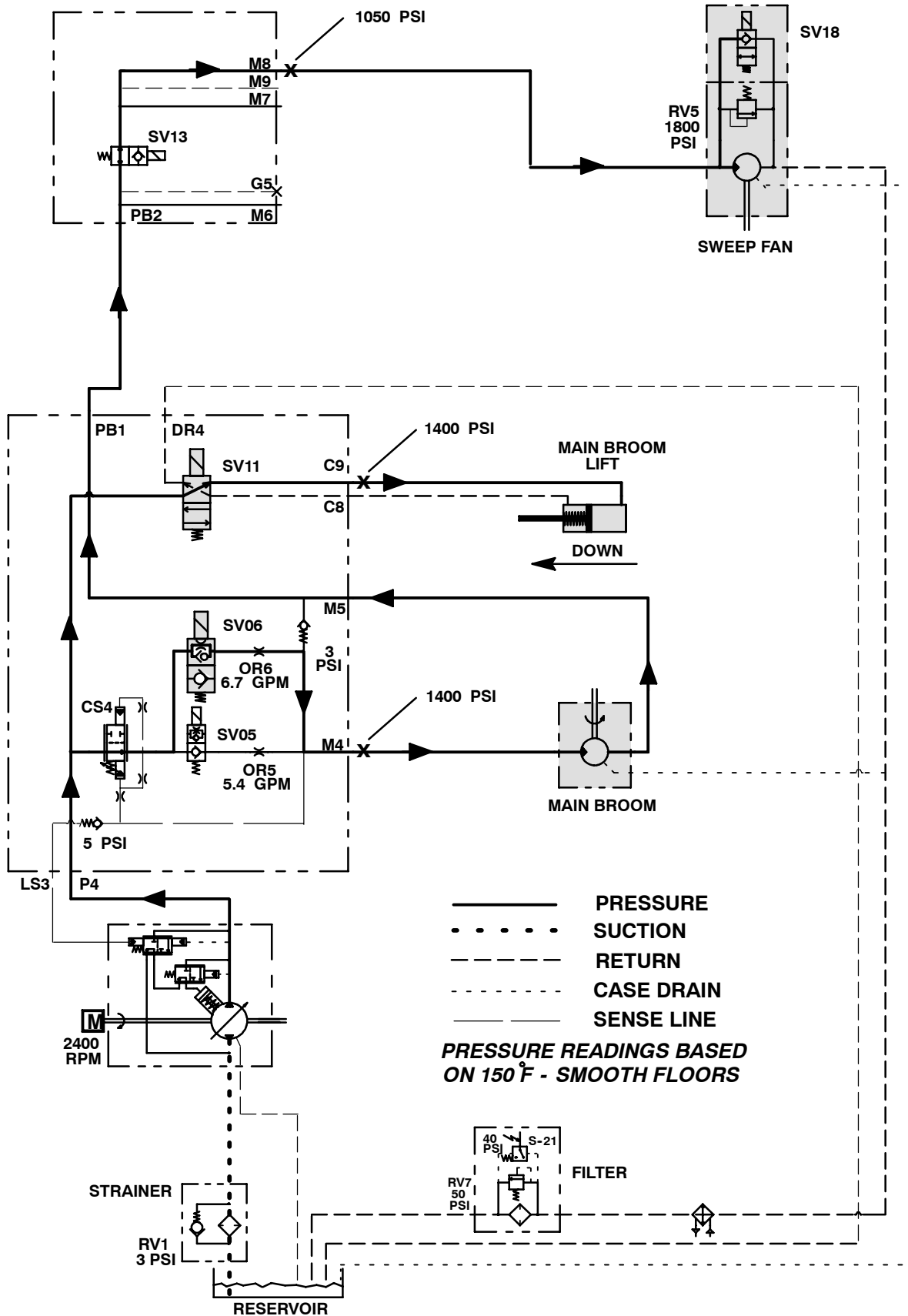

MAIN BRUSH DOES NOT RAISE

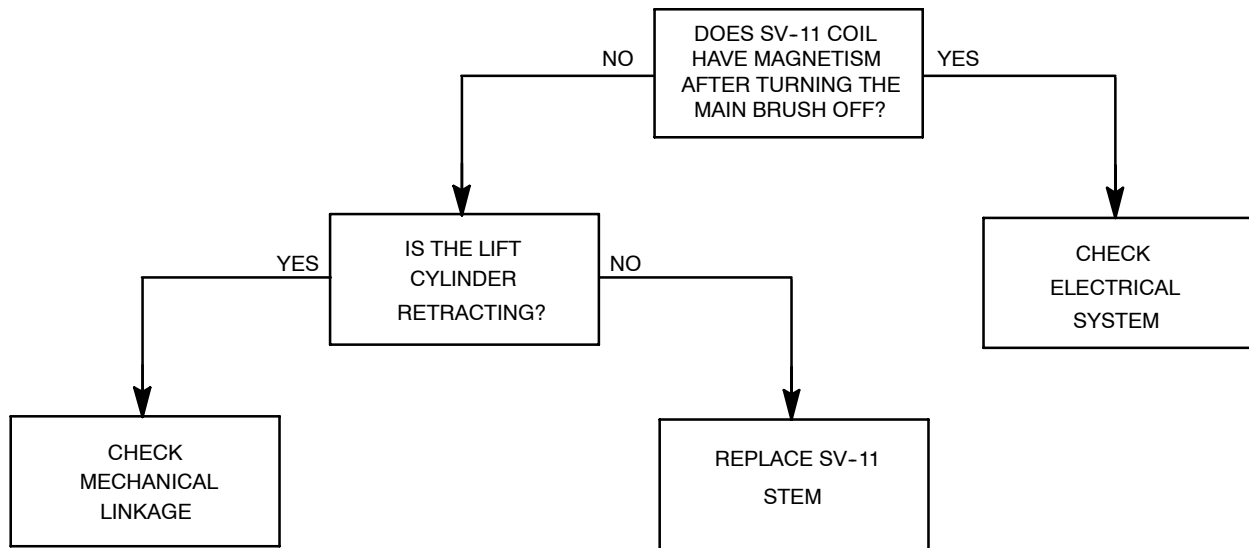

MAIN BRUSH DOES NOT LOWER

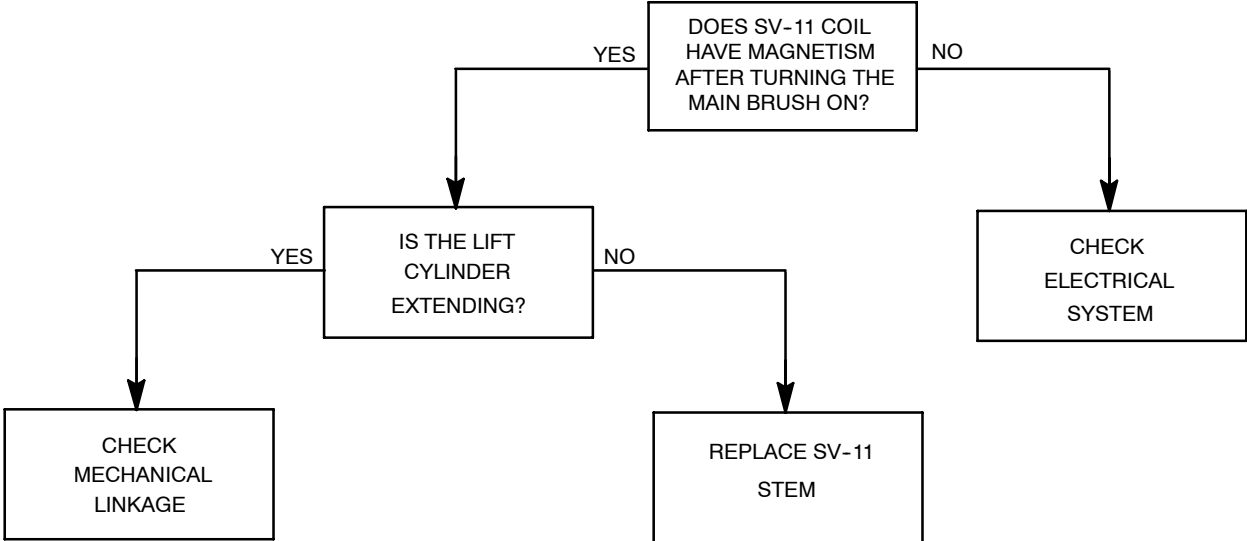

MAIN BRUSH DOES NOT
TURN OFF

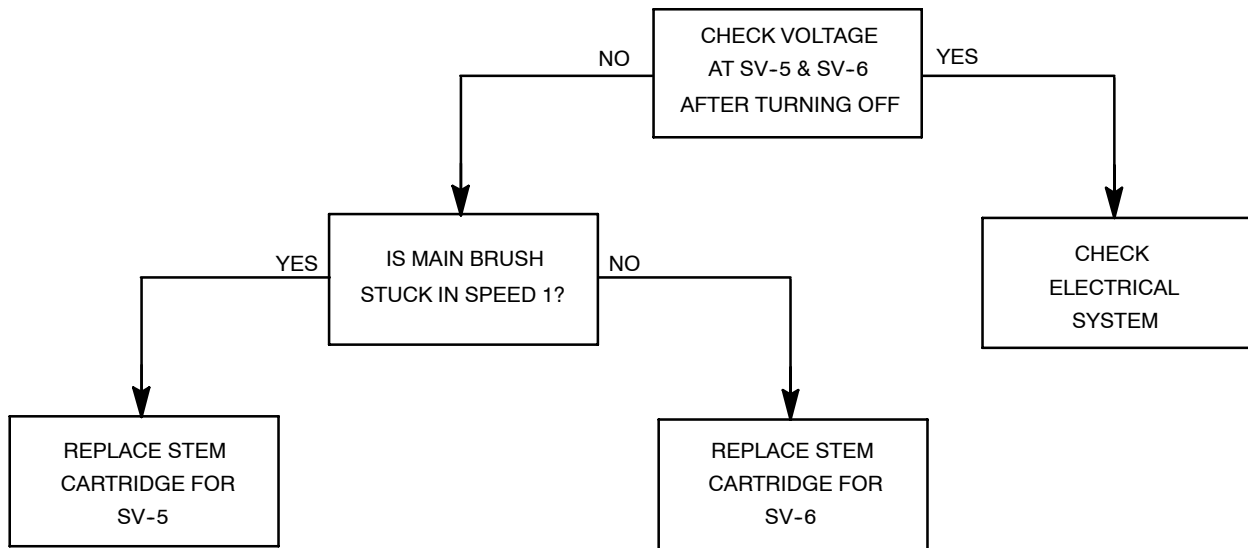

**MAIN BRUSH DOES NOT
TURN ON**

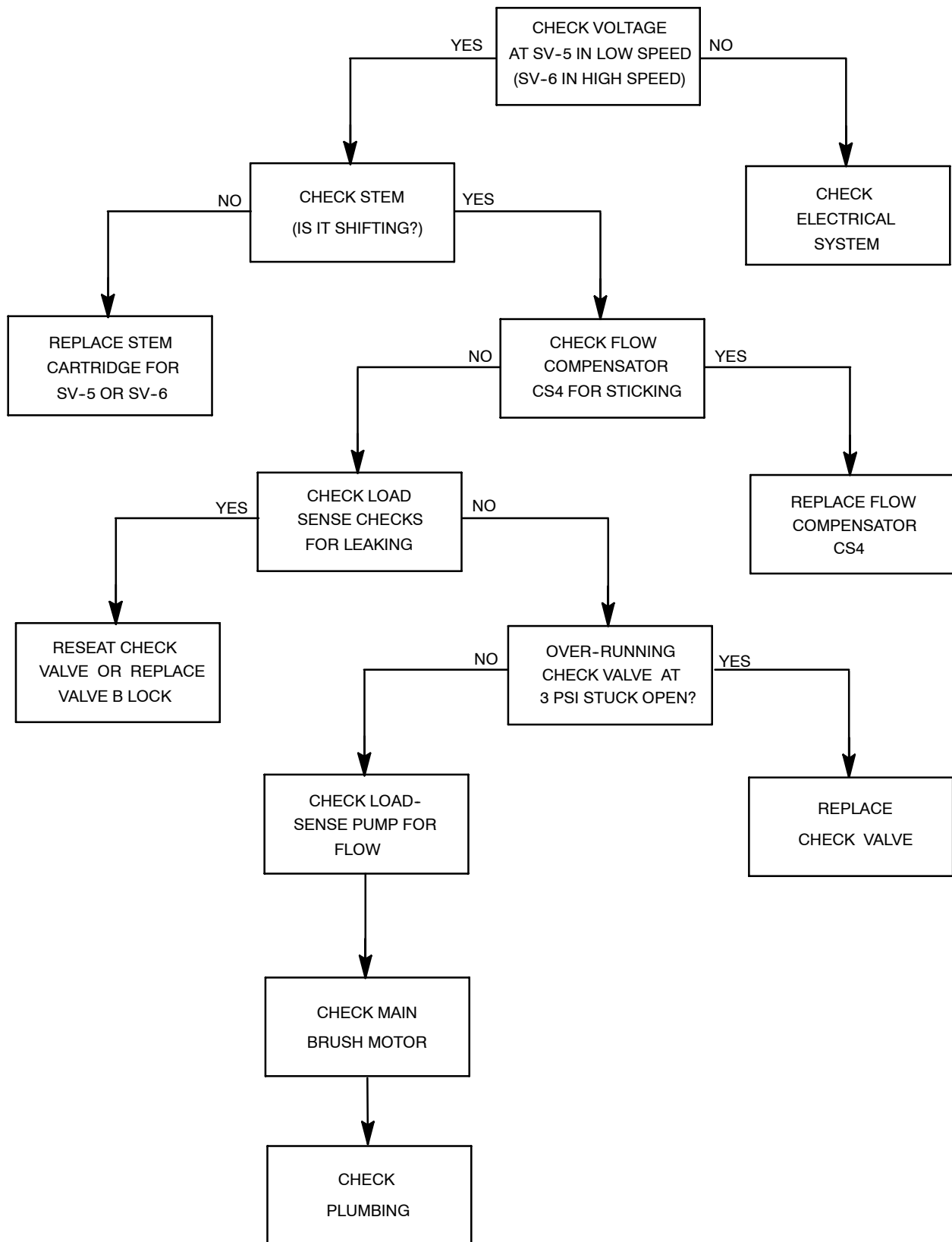

SWEEPER FAN DOES NOT TURN OFF

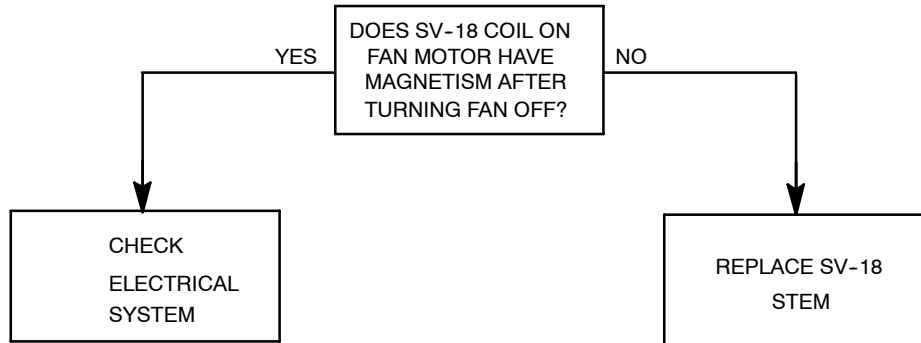

SWEeper FAN DOES NOT TURN ON

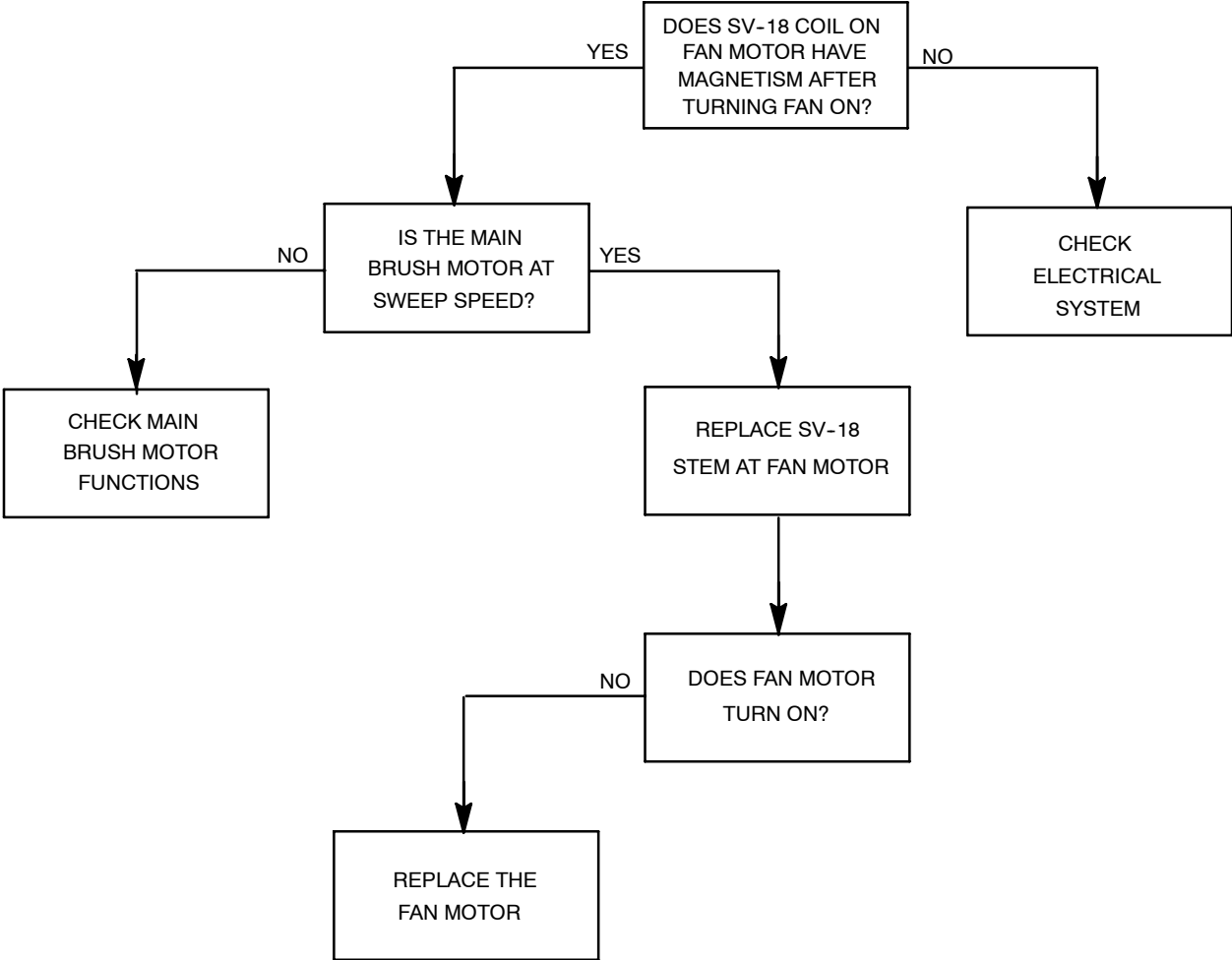

SIDE BRUSH CIRCUIT - SPD 1
 (MAIN BRUSH ON, VAC FAN ON, SIDE BRUSH DOWN AND ON)

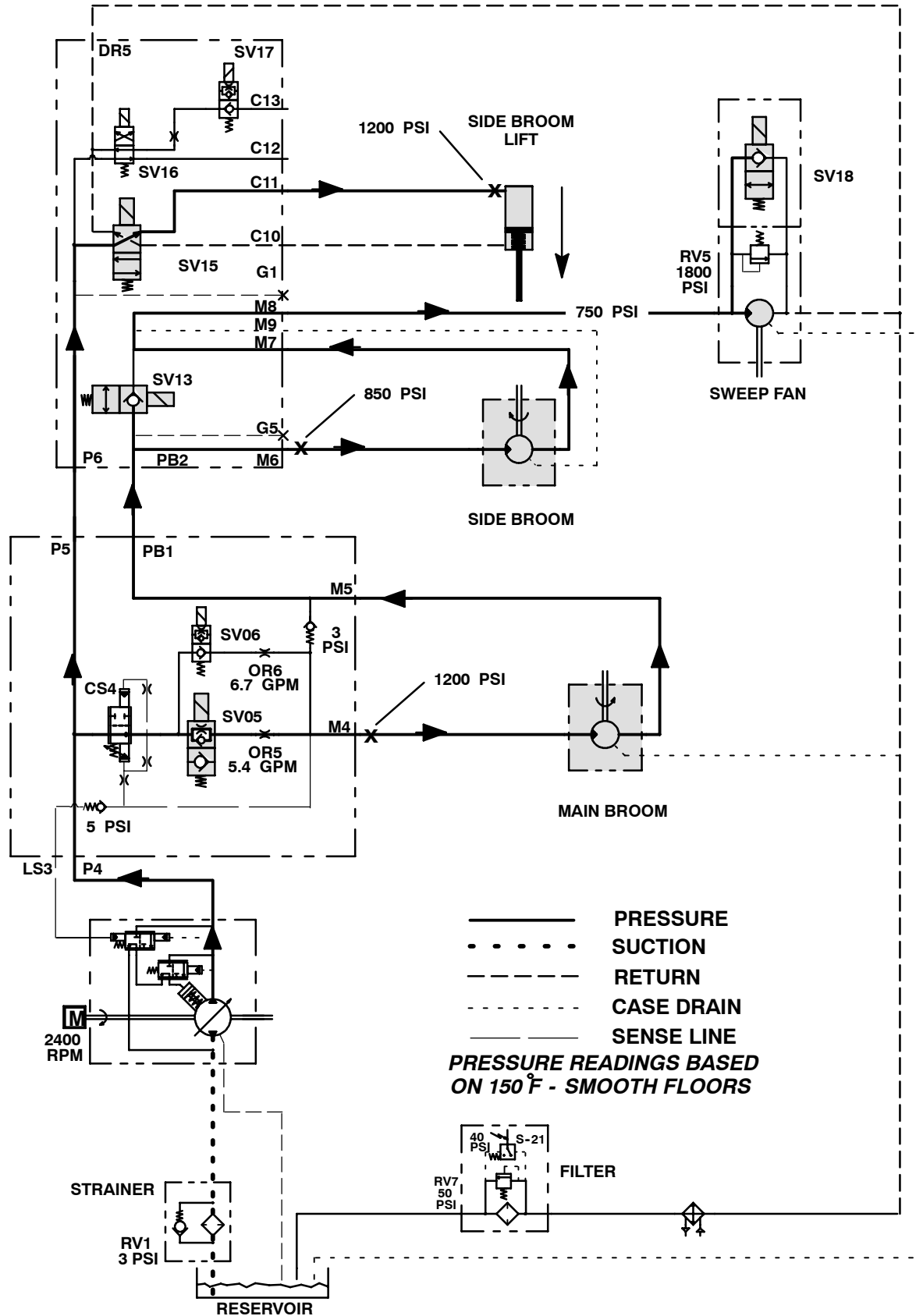

SIDE BRUSH CIRCUIT - SPD 2
 (MAIN BRUSH ON, VAC FAN ON, SIDE BRUSH DOWN AND ON)

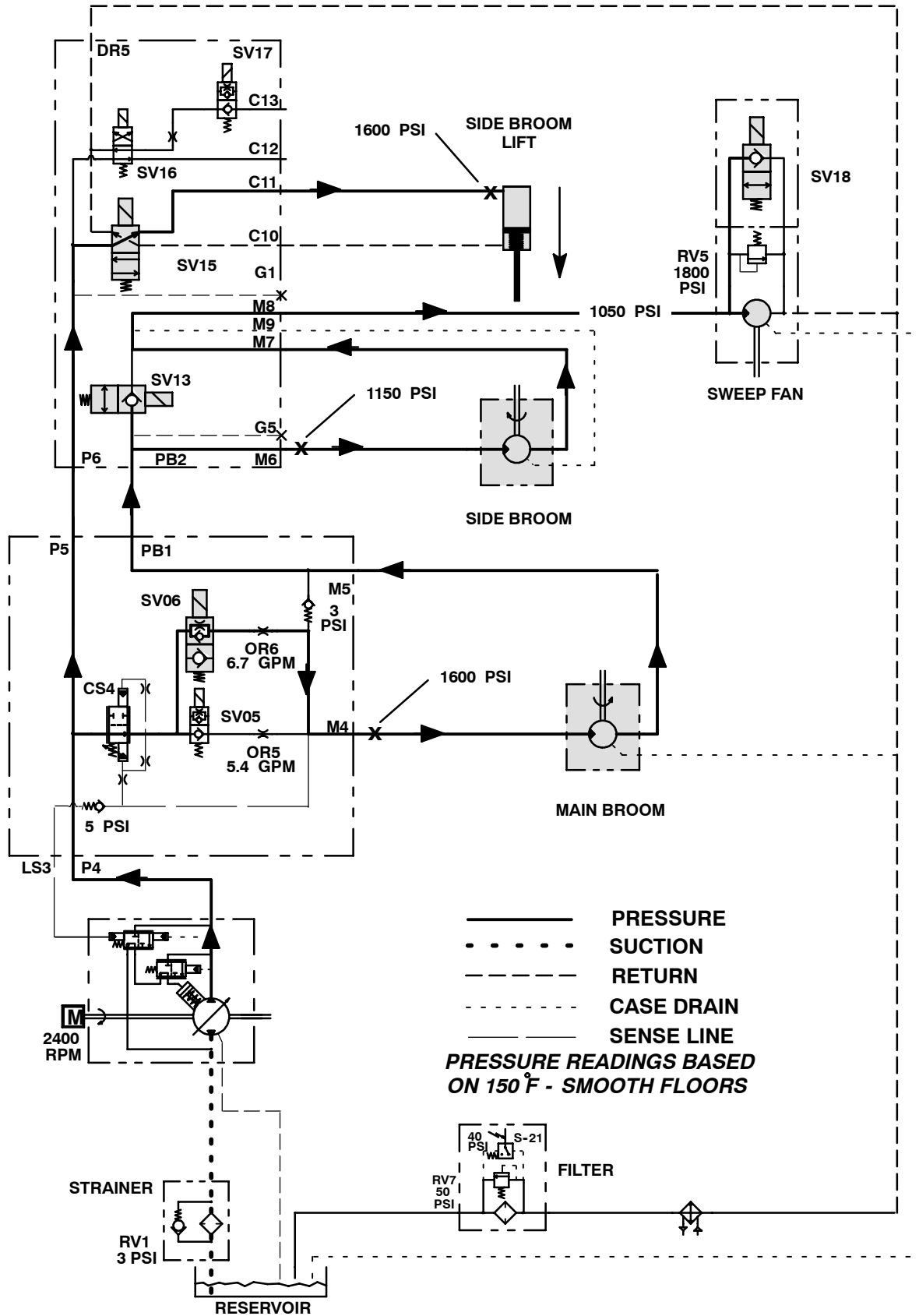

SIDE BRUSH DOES NOT RAISE

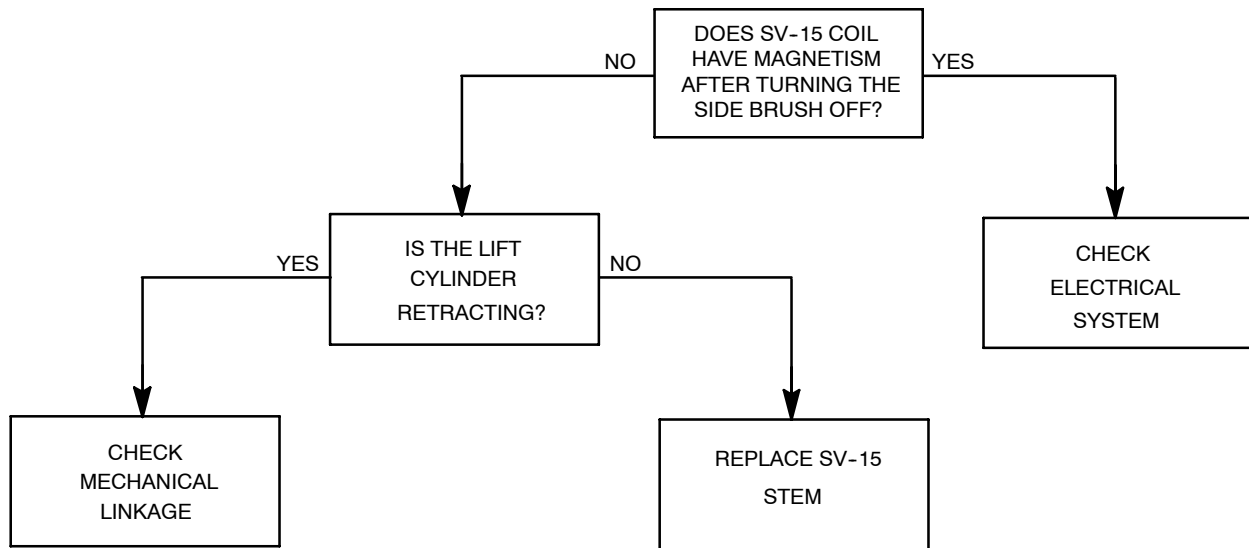

SIDE BRUSH DOES NOT LOWER

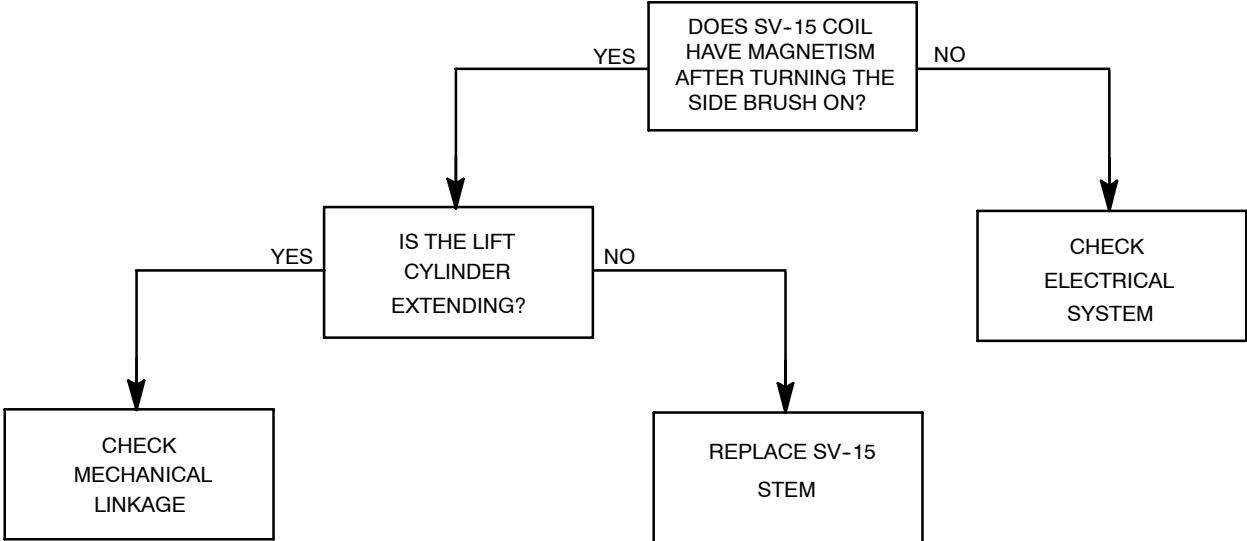

**SIDE BRUSH DOES NOT
TURN OFF**

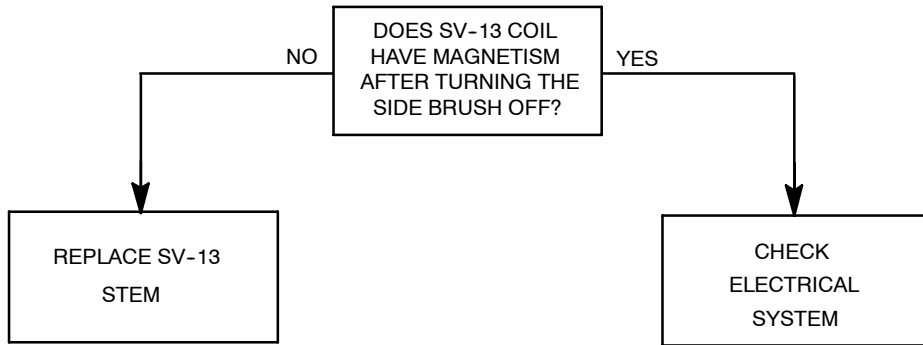

**SIDE BRUSH DOES NOT
TURN ON**

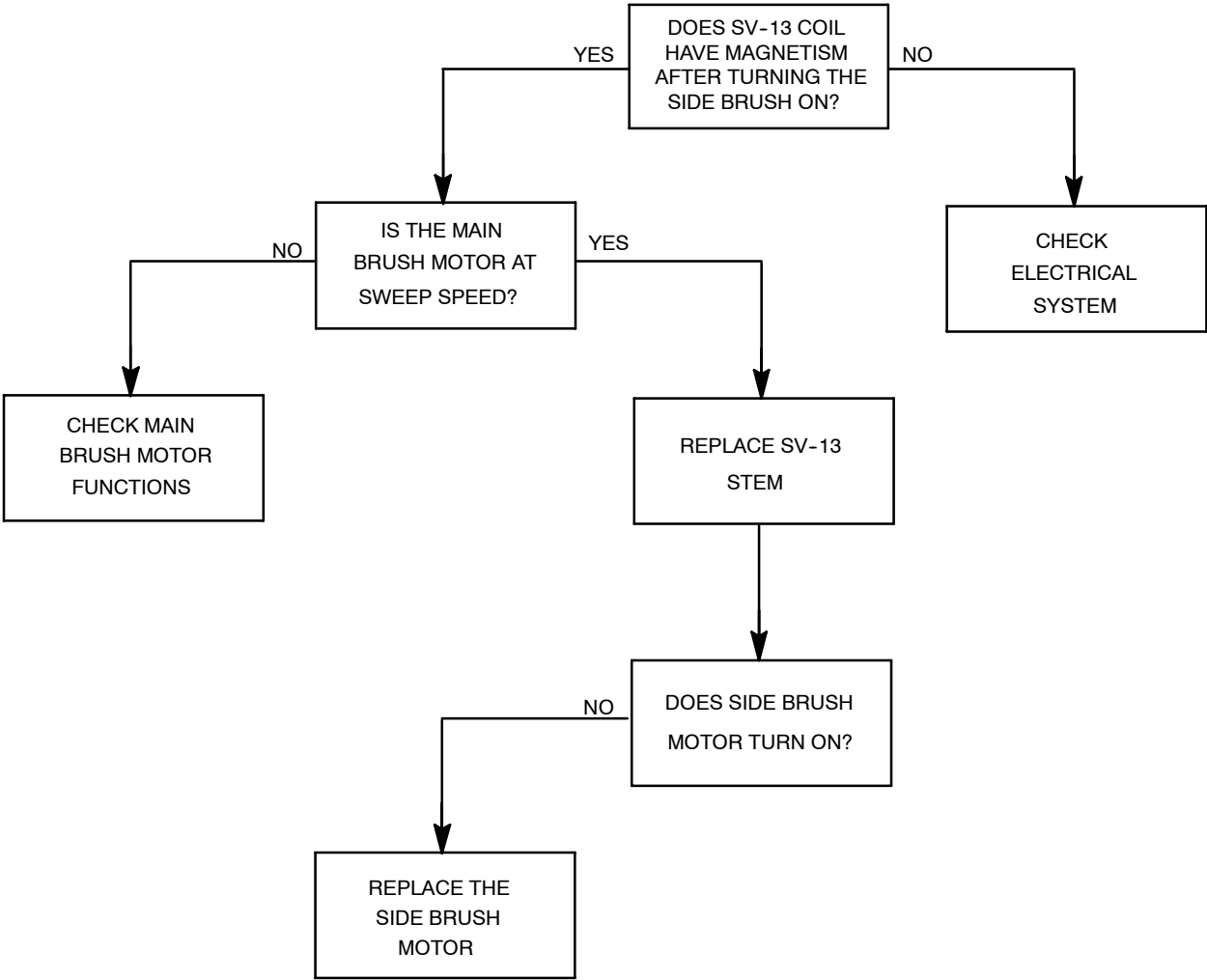

EDGE SCRUB CIRCUIT

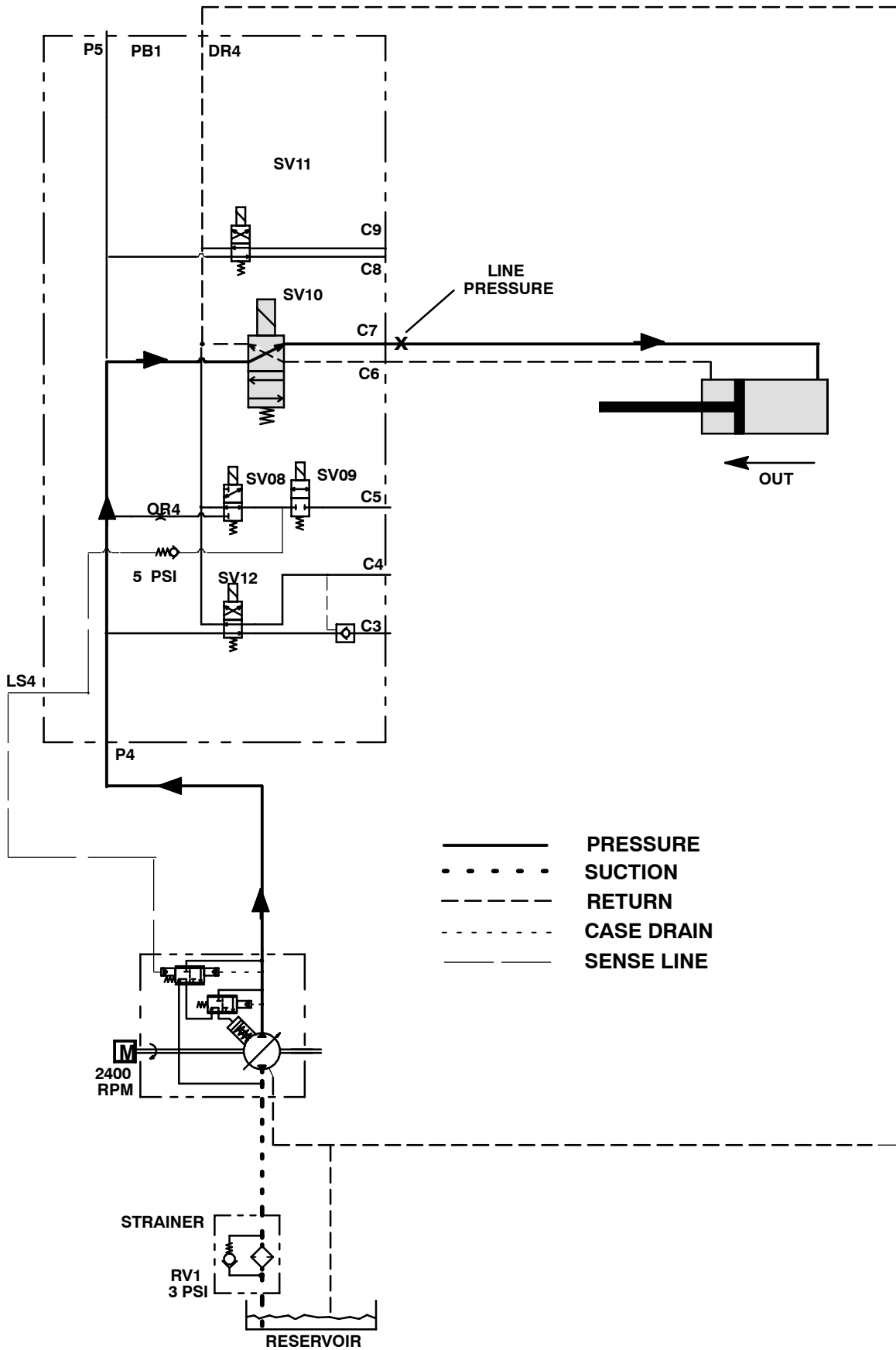

SCRUB HEAD DOES NOT GO IN

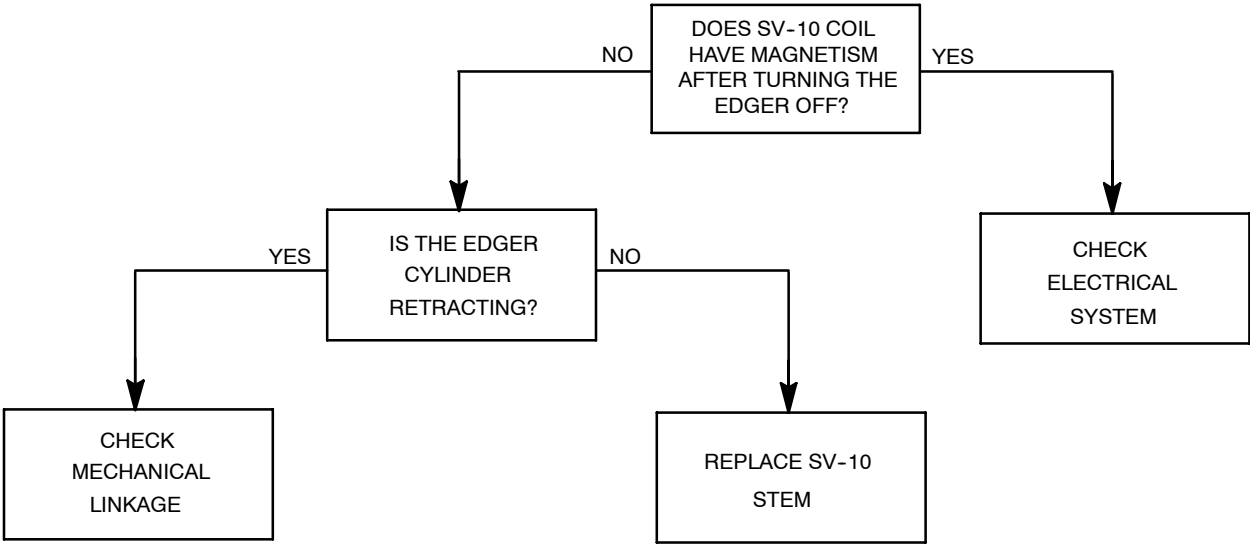

SCRUB HEAD DOES NOT GO OUT

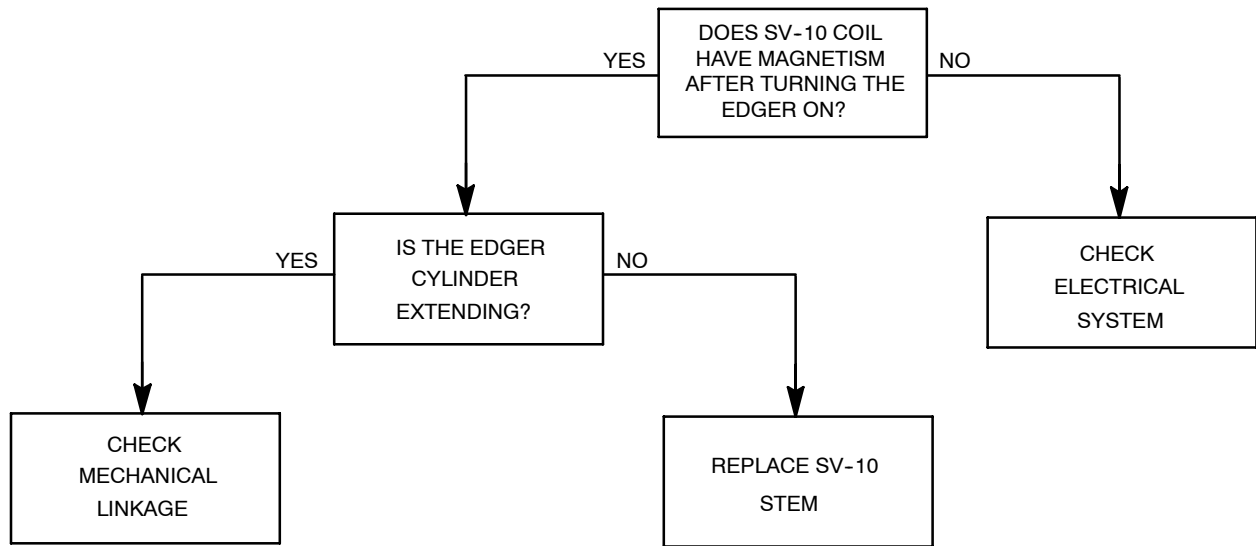

SCRUB HEAD LOWER CIRCUIT

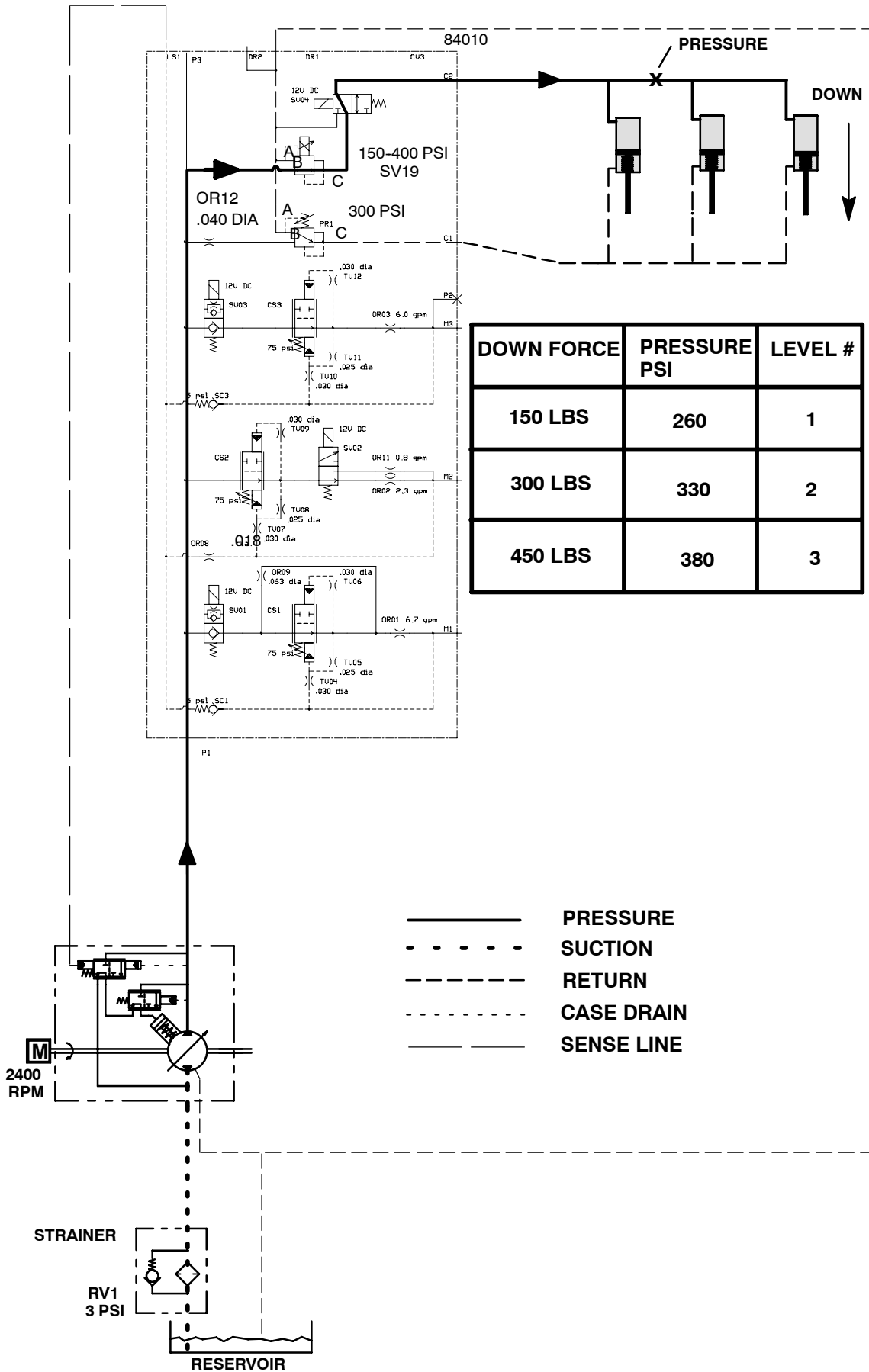

SCRUB BRUSHES DO NOT LOWER

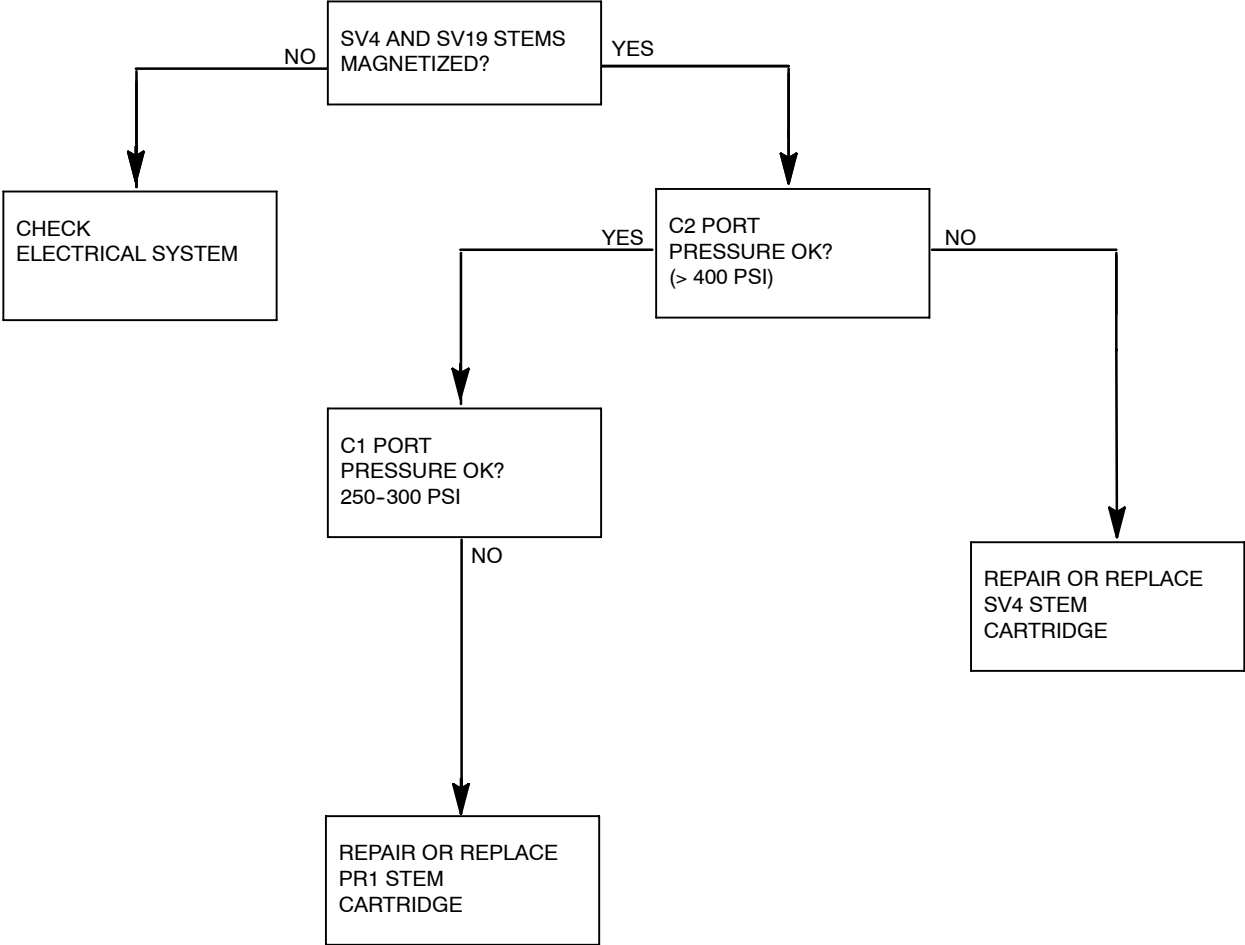

SCRUB HEAD RAISE CIRCUIT

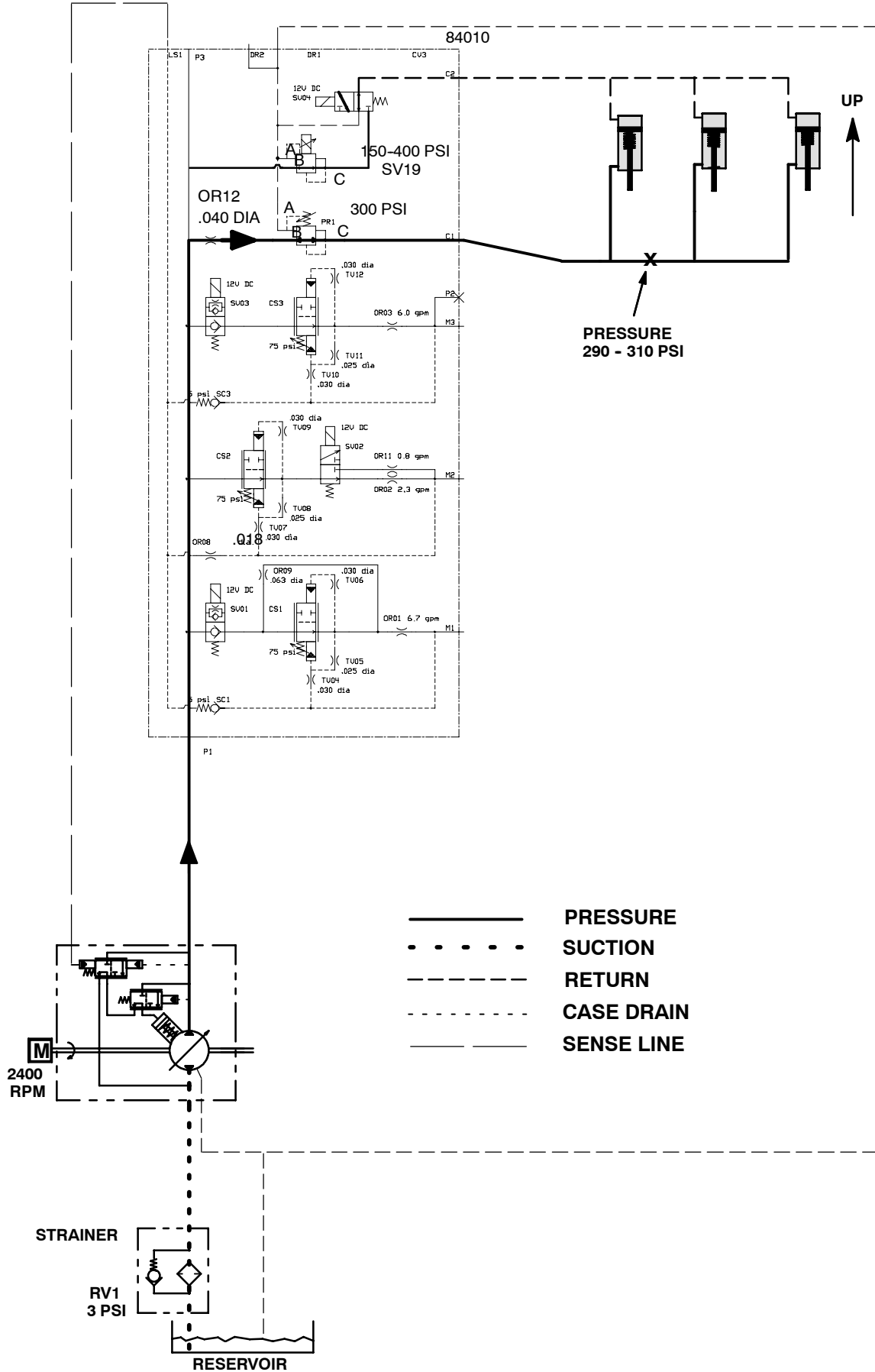

SCRUB BRUSHES DO NOT RAISE

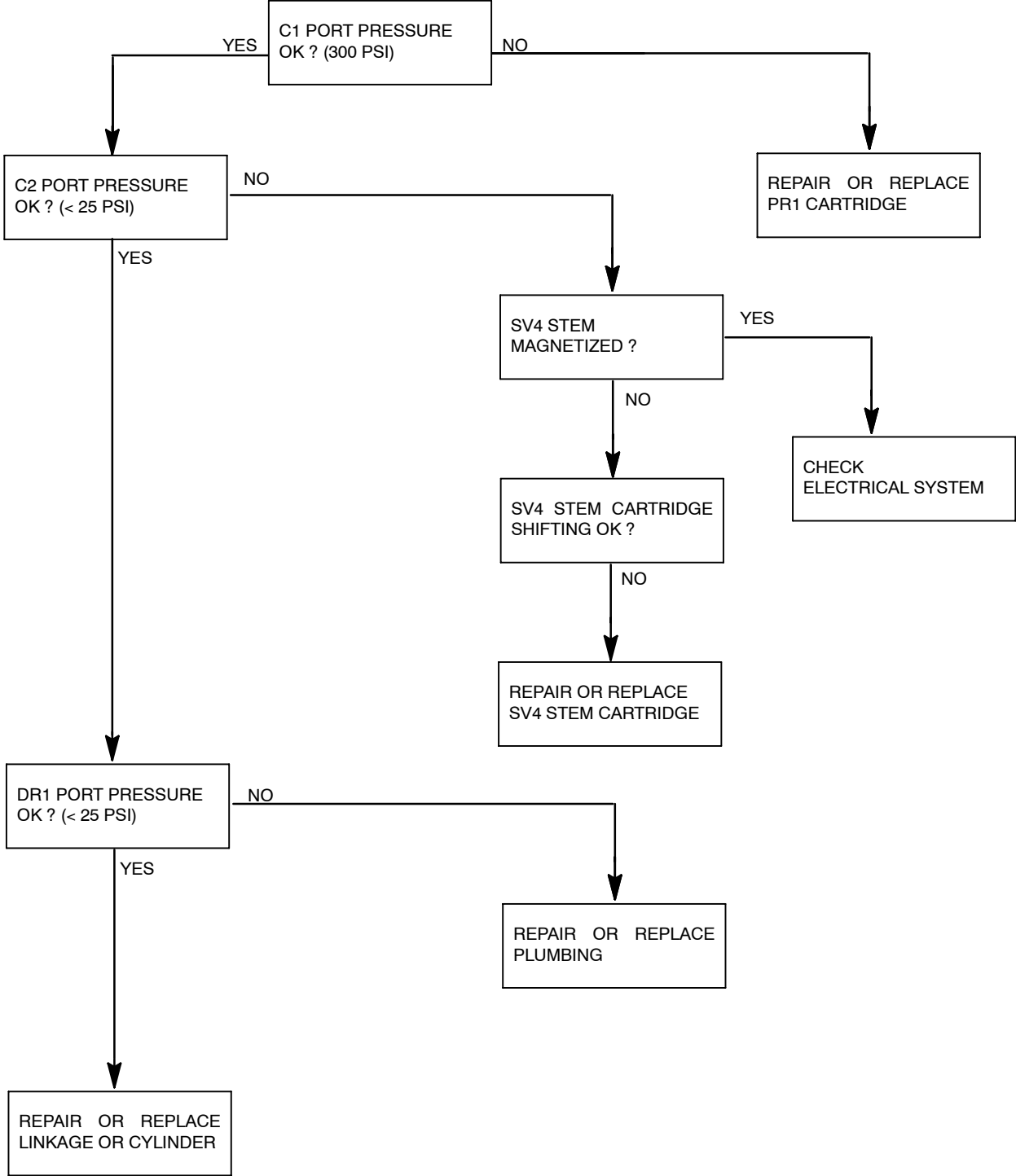

SCRUB BRUSH CIRCUIT

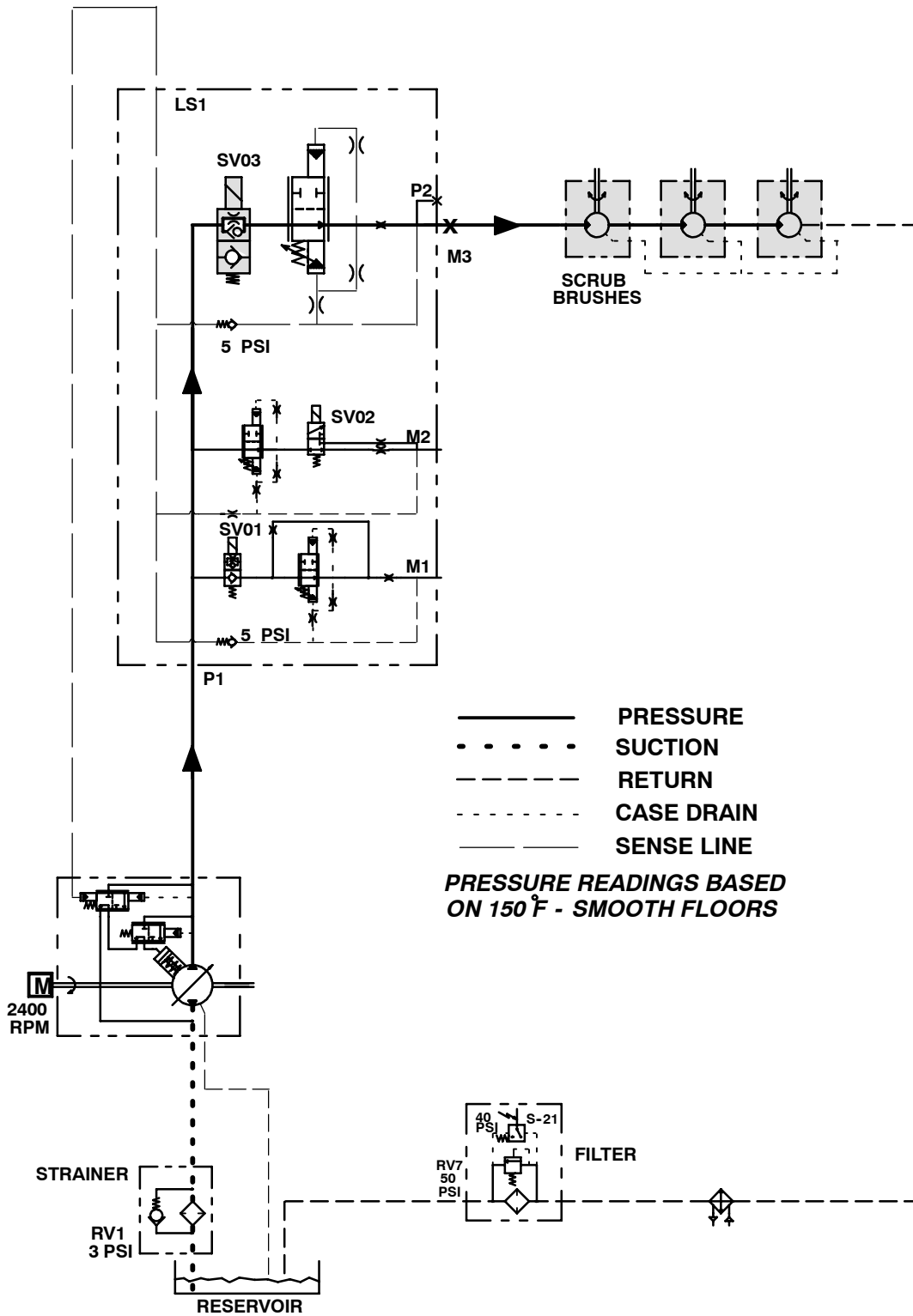

**SCRUB BRUSHES DO NOT
TURN OFF**

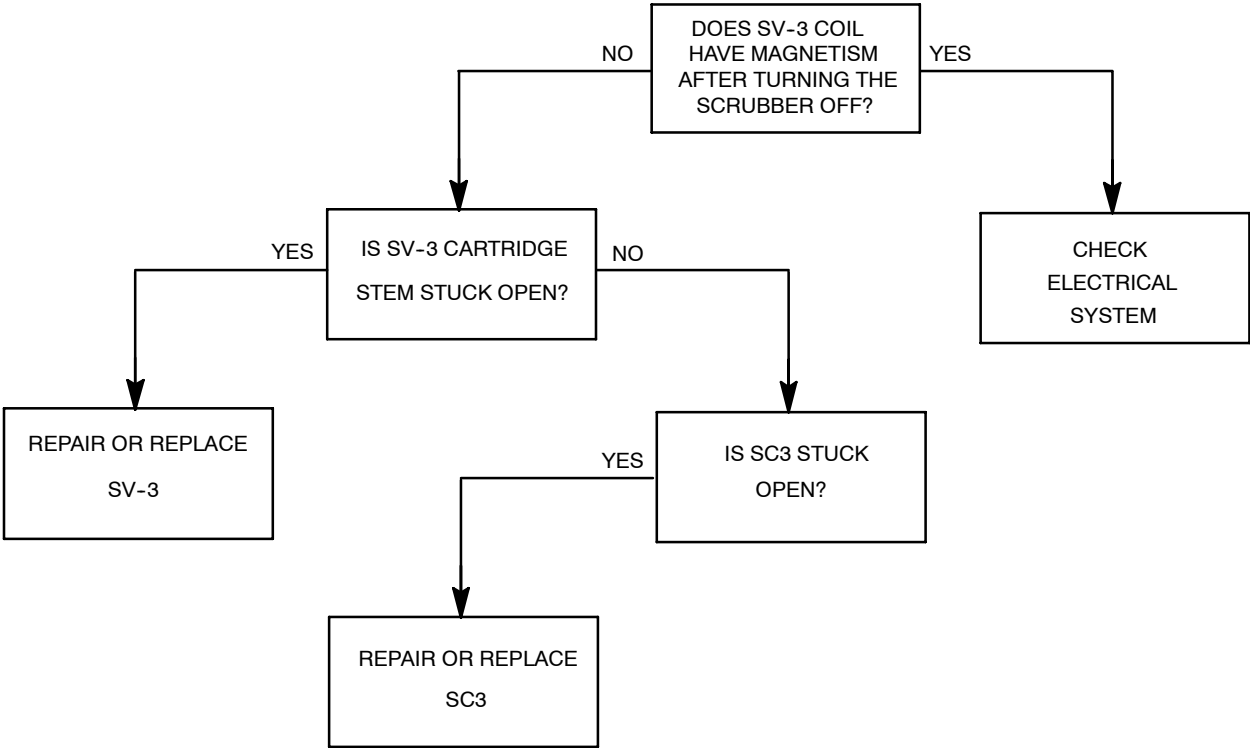

SCRUB BRUSHES DO NOT TURN ON

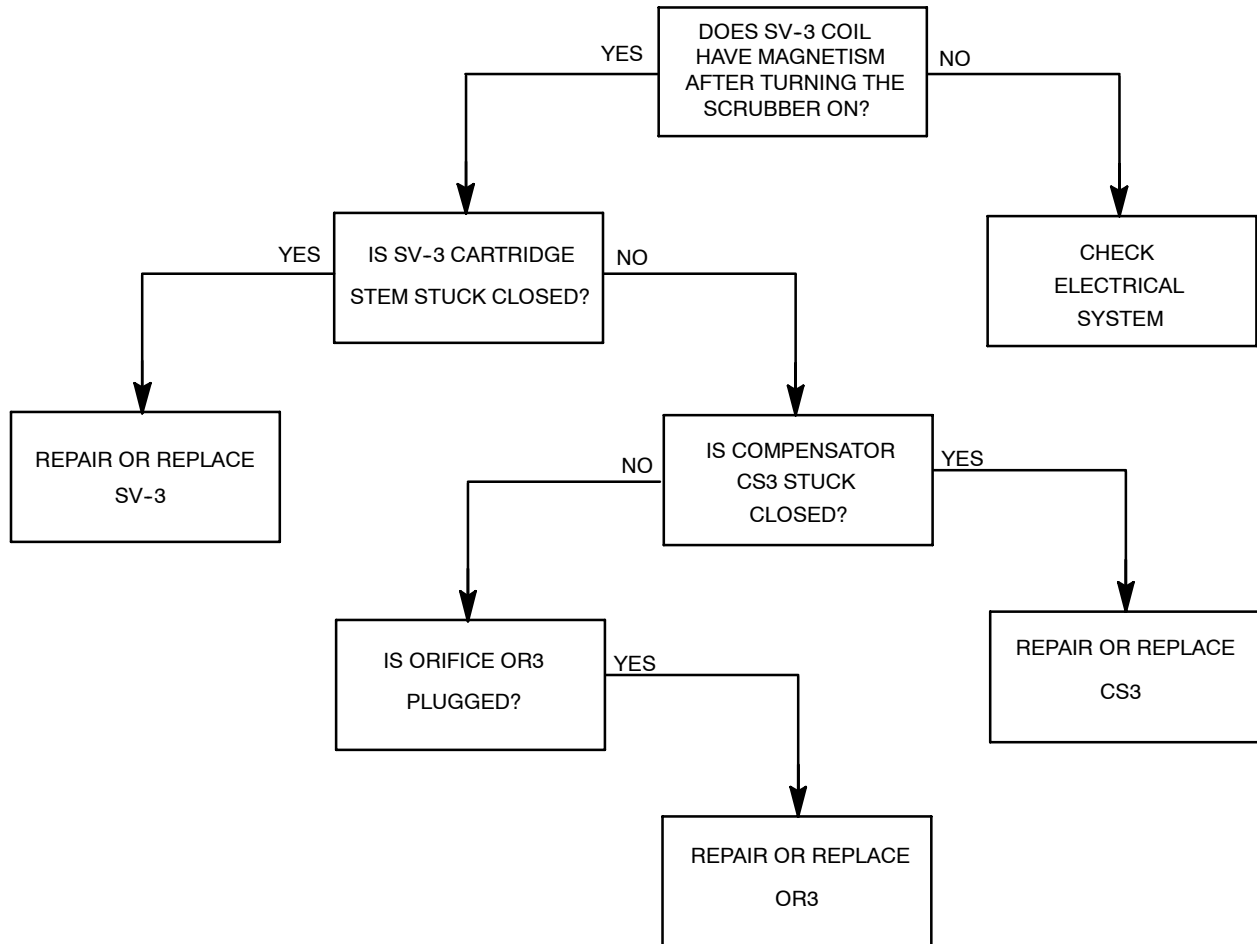

SQUEEGEE LIFT CIRCUIT

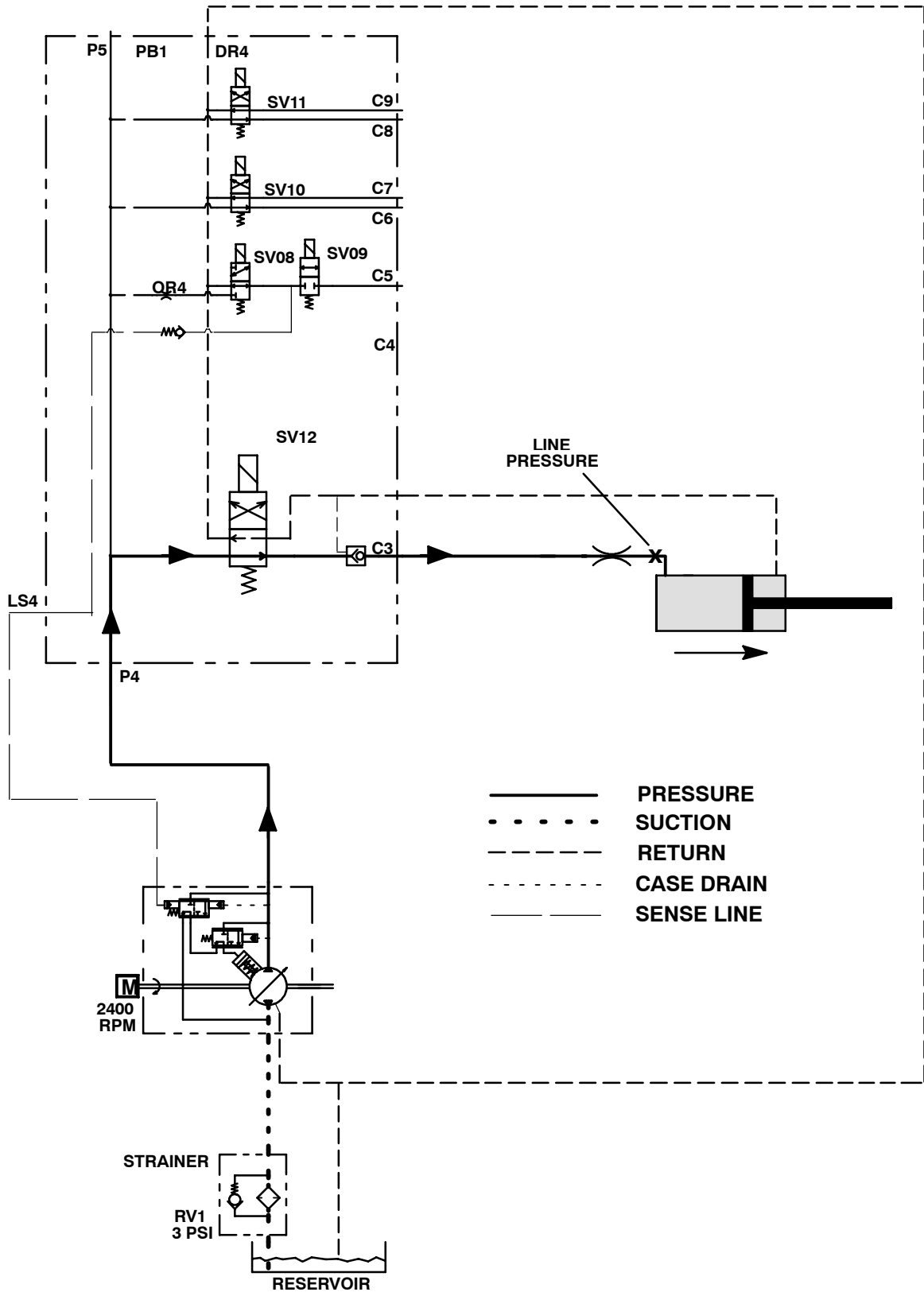

SQUEEGEE DOES NOT RAISE

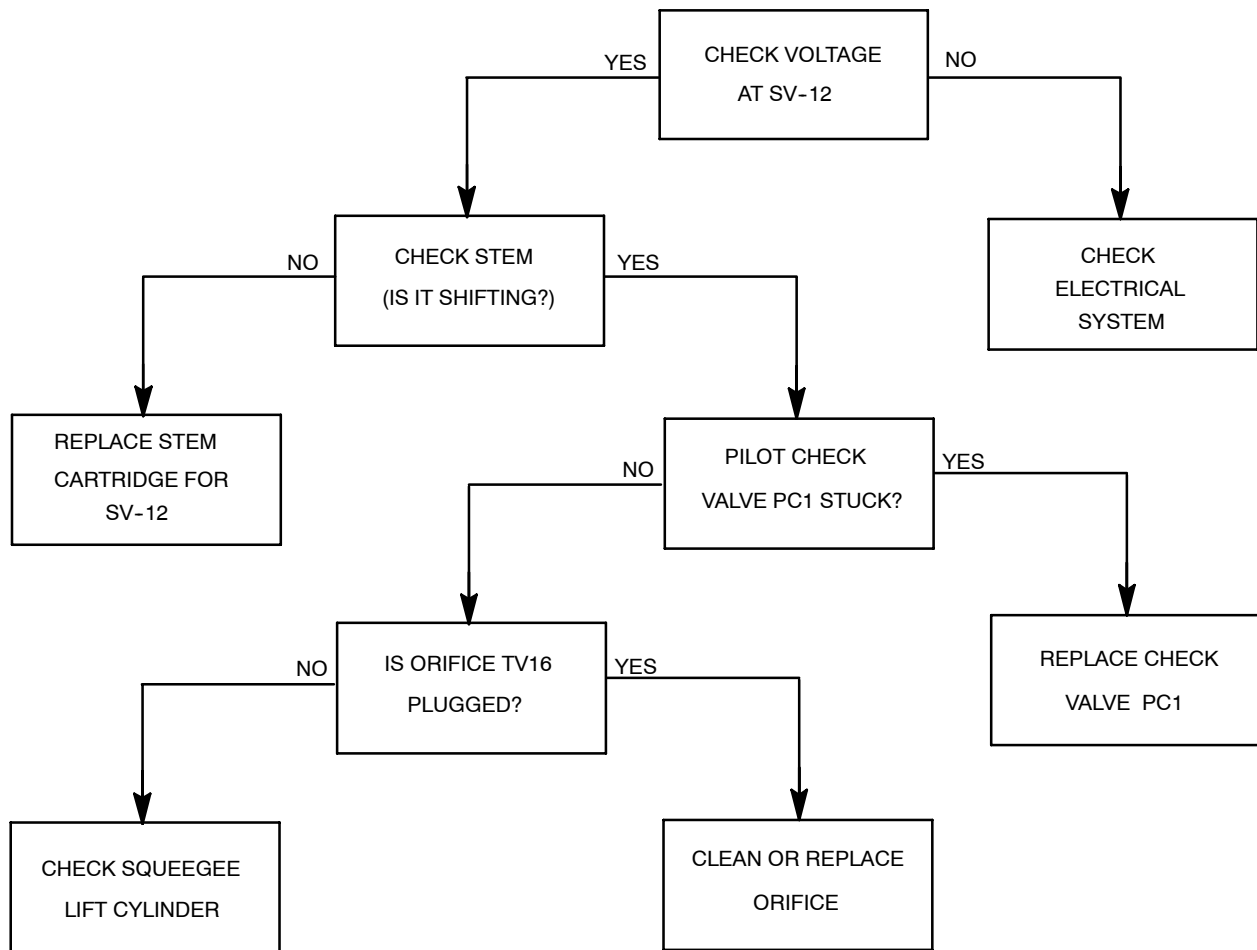

SQUEEGEE DRIFTS DOWN TOO QUICKLY

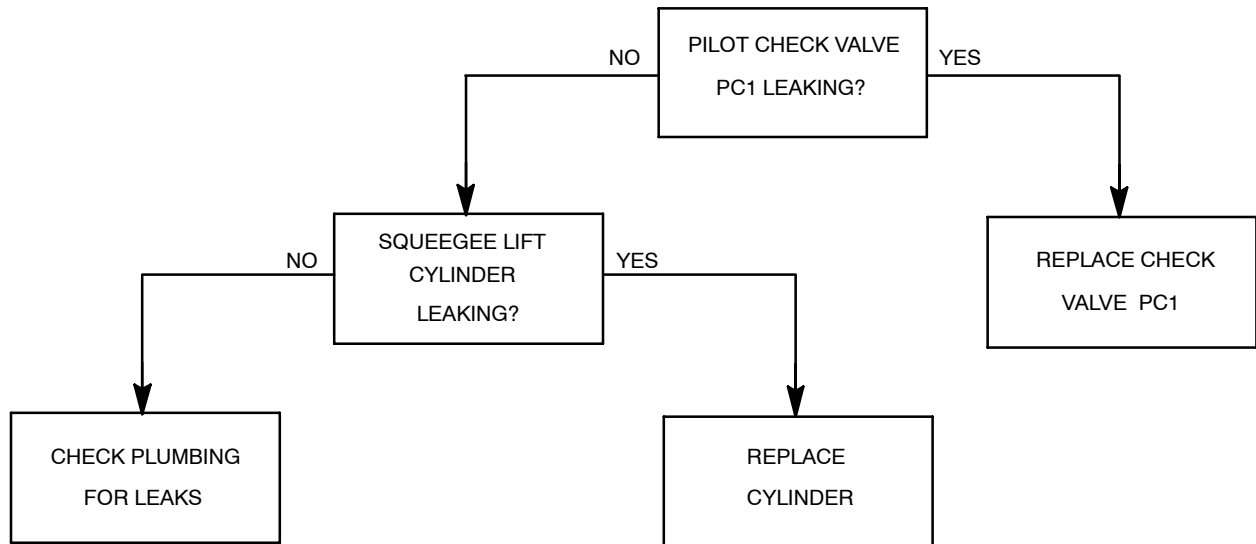

SQUEEGEE LOWER CIRCUIT

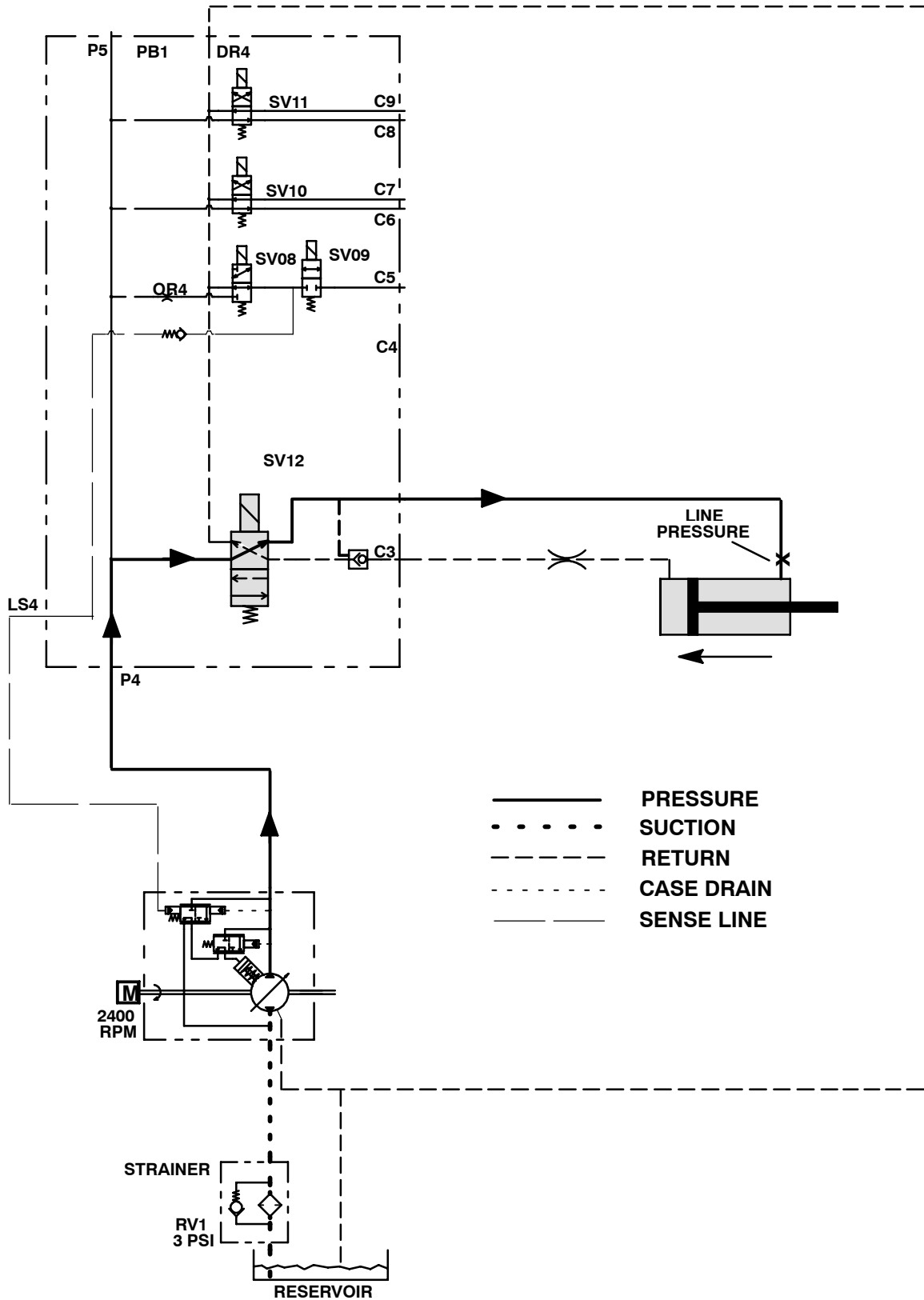

SQUEEGEE DOES NOT LOWER

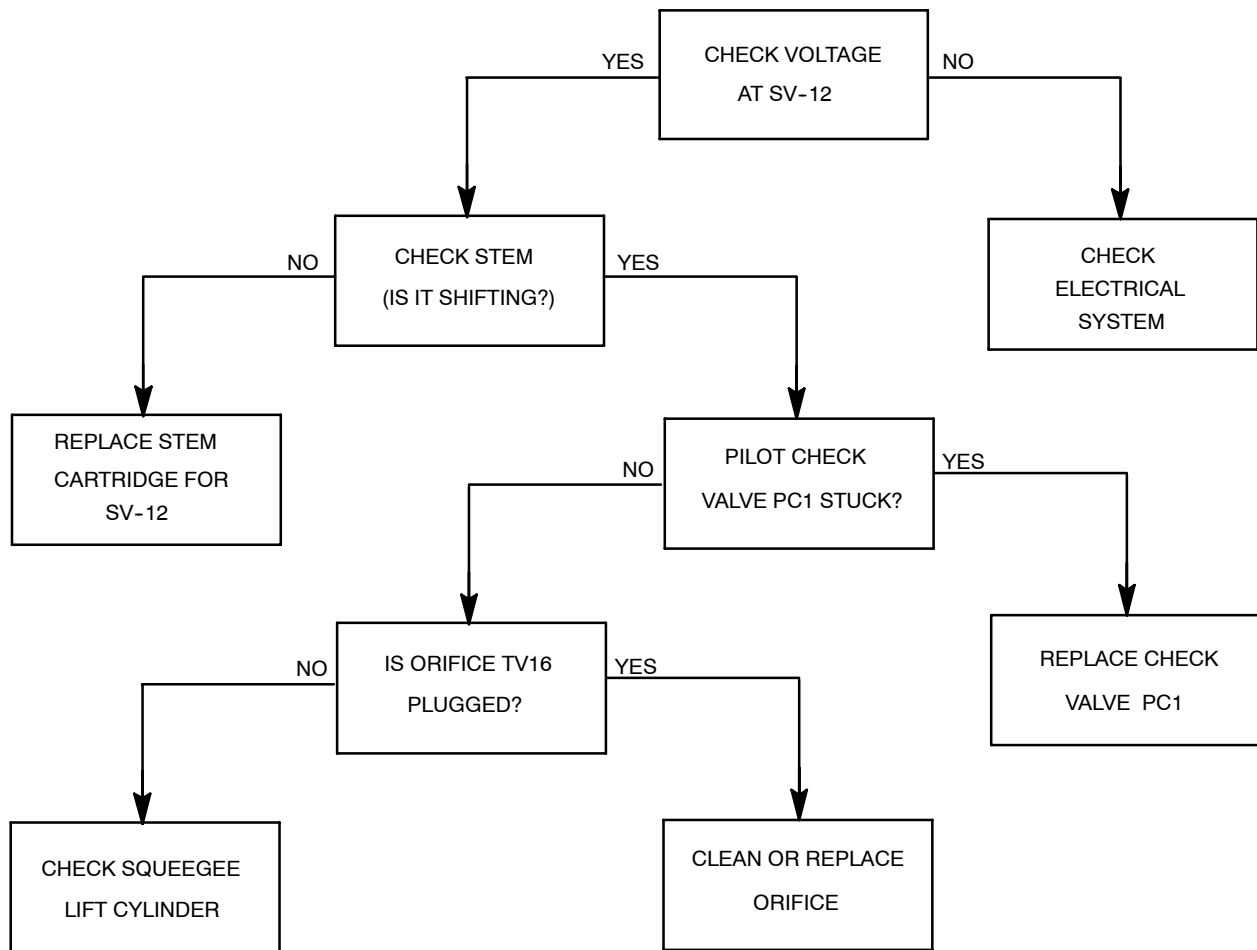

LEFT TURN CIRCUIT

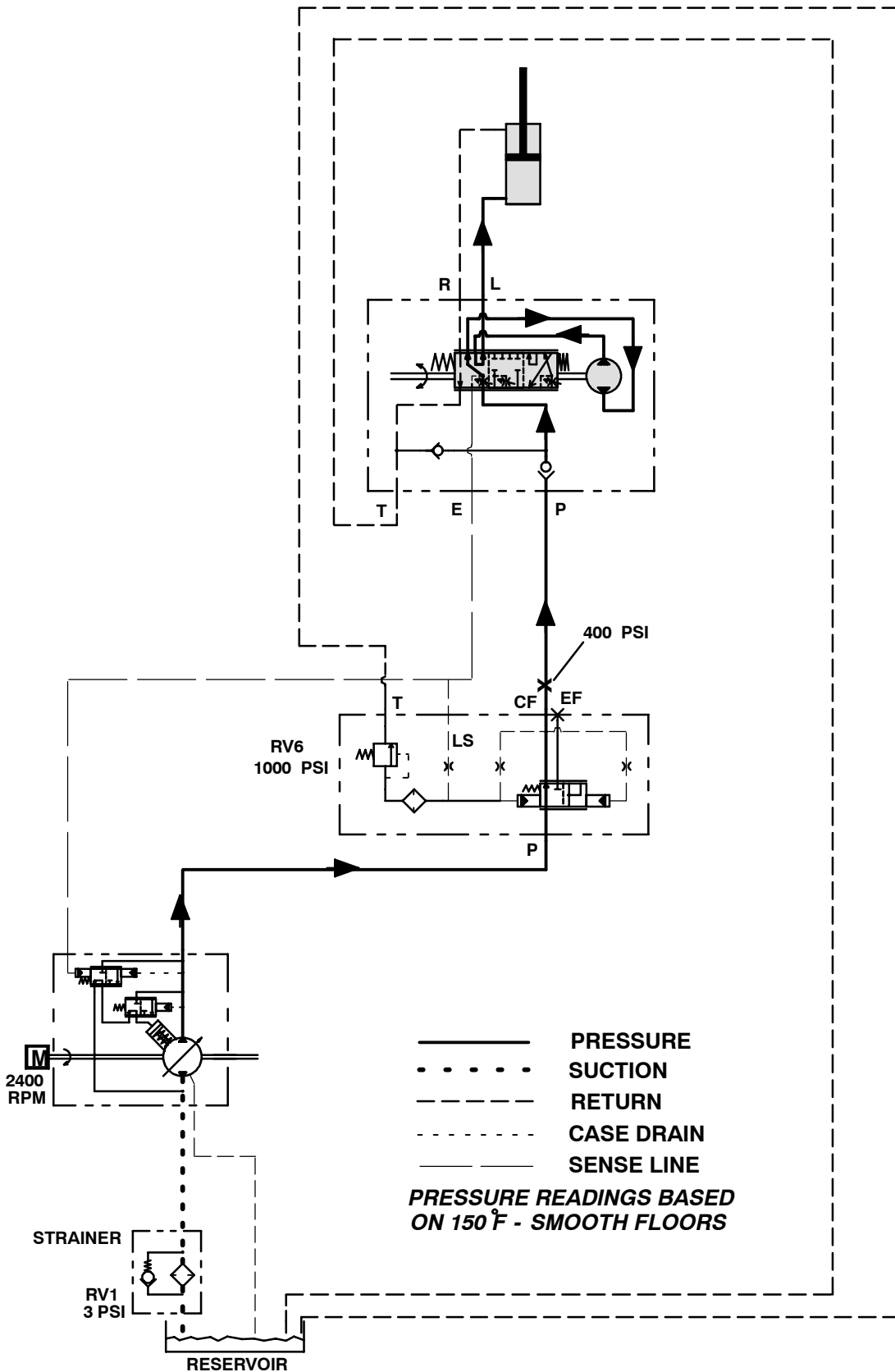

RIGHT TURN CIRCUIT

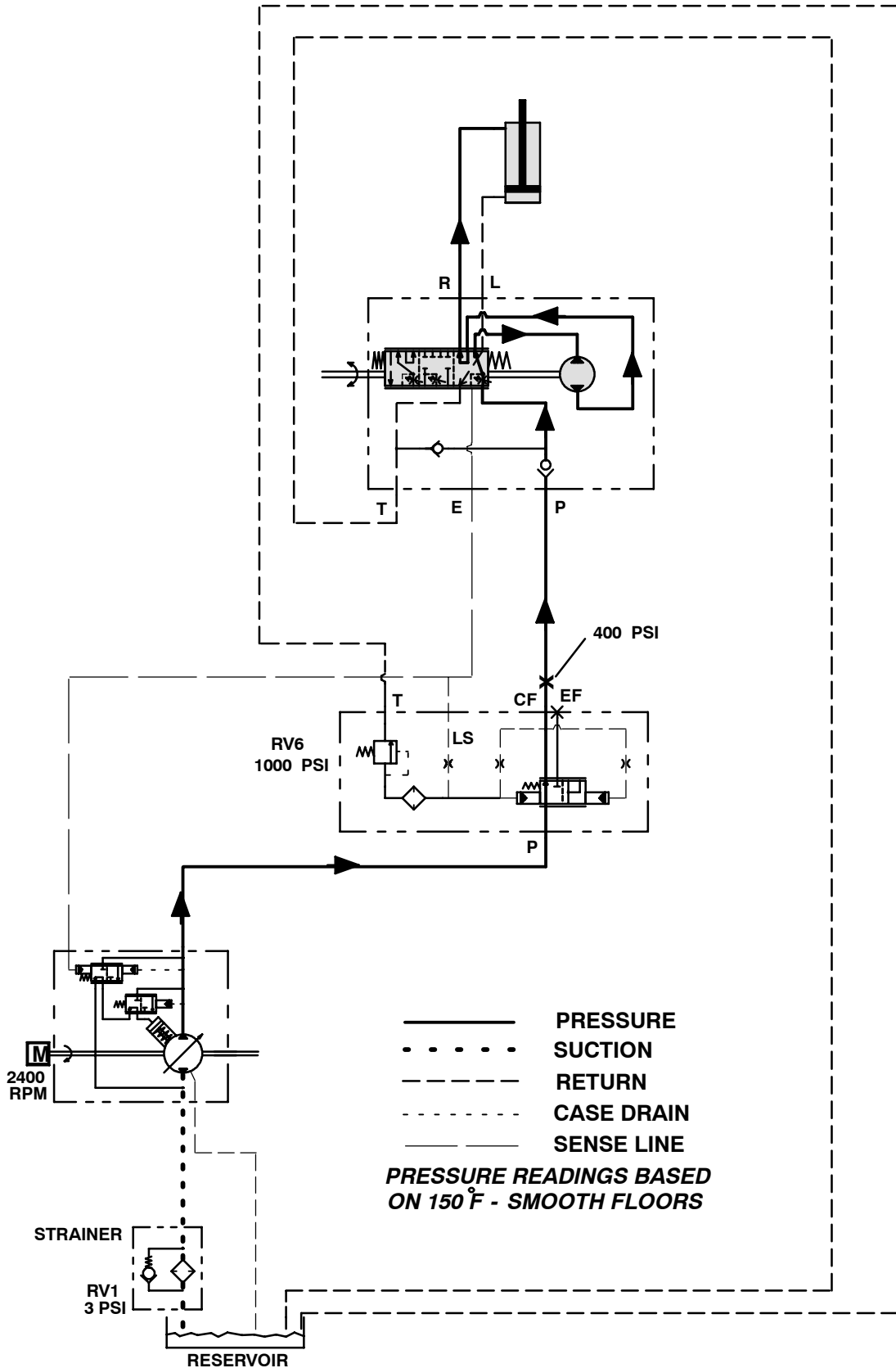

CONTENTS

| | Page |
|------------------------------|------|
| INTRODUCTION | 7-3 |
| LUBRICATION | 7-4 |
| ENGINE OIL | 7-4 |
| COOLING SYSTEM | 7-5 |
| RADIATOR | 7-5 |
| ENGINE FAN BELT | 7-5 |
| AIR INTAKE SYSTEM | 7-6 |
| AIR FILTER INDICATOR | 7-6 |
| AIR FILTER | 7-7 |
| TO REPLACE AIR FILTER | |
| ELEMENT | 7-7 |
| FUEL SYSTEM - GASOLINE | 7-9 |
| FUEL FILTERS | 7-9 |
| CARBURETOR | 7-9 |
| FUEL SYSTEM - LPG | 7-10 |
| FUEL TANKS | 7-12 |
| TO CHANGE LPG FUEL TANK .. | 7-14 |
| FUEL FILTER LOCK | 7-15 |
| VAPORIZER-REGULATOR | 7-15 |
| CARBURETOR | 7-15 |
| OIL PRESSURE SWITCH | 7-15 |
| LPG FUEL TROUBLESHOOTING ... | 7-16 |
| GOVERNOR | 7-17 |
| TO ADJUST GOVERNOR | |
| CONTROL BOX | 7-17 |
| DIGITAL CONTROLLER SET-UP | 7-18 |
| GOVERNOR | |
| TROUBLESHOOTING | 7-19 |
| IGNITION SYSTEM | 7-22 |
| SPARK PLUGS | 7-22 |
| TO REPLACE SPARK PLUGS ... | 7-22 |
| ENGINE IGNITION TIMING | 7-22 |
| TIMING BELT | 7-22 |
| CYLINDER HEAD | 7-23 |
| VALVE TAPPET CLEARANCE ... | 7-23 |
| CRANKCASE VENTILATION | |
| SYSTEM | 7-23 |
| INTAKE MANIFOLD | 7-23 |
| TO CHANGE ENGINE TIMING BELT | 7-24 |
| TO REPLACE ALTERNATOR | 7-26 |
| TO REPLACE STARTER | 7-28 |
| TO REMOVE ENGINE | 7-30 |
| TO INSTALL ENGINE | 7-32 |

GAS ENGINE SERVICE MANUALS

FORD LRG-423 (2.3 Litre)
TENNANT Part Number 21791

FORD LRG-425 (2.5 Litre)
TENNANT Part Number 385439

INTRODUCTION

This section includes repair information on the engine and related systems, such as fuel, electrical, and drive belts.

LUBRICATION

ENGINE OIL

Check the engine oil level daily. Change the engine oil and oil filter every 100 hours of machine operation. Use 10W30 SAE-SG/SH rated engine oil.

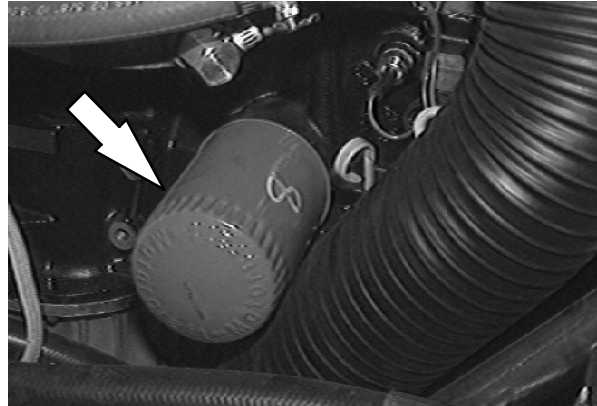

Fill the engine with oil to the level indicated on the oil dipstick. The engine oil capacity is 4.7 L (5 qt) including the oil filter.

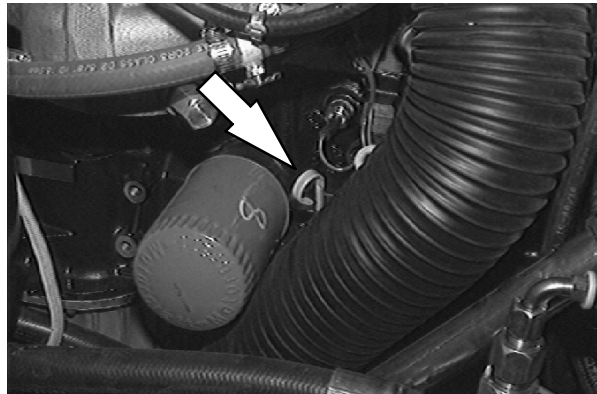

COOLING SYSTEM

RADIATOR

Check the radiator coolant every 100 hours of operation. Use clean water mixed with a permanent-type, ethylene glycol antifreeze to a -34°C (-30°F) rating.

FOR SAFETY: When Servicing Machine, Avoid Contact With Hot Engine Coolant.

ATTENTION! Never pour cold water or cold antifreeze into the radiator of an overheated engine. Allow the engine to cool down to avoid cracking the cylinder head or block. Keep the engine running while adding water.

Check the radiator hoses and clamps every 200 hours of operation. Tighten the clamps if they are loose. Replace the hoses and clamps if the hoses are cracked, harden, or swollen.

Check the radiator core exterior and hydraulic cooler fins for debris every 100 hours of operation. Blow or rinse all dust, which may have collected on the radiator, in through the grille and radiator fins, in the direction of normal air flow. The grille and hydraulic cooler open for easier cleaning. Be careful not to bend the cooling fins when cleaning. Clean thoroughly to prevent the fins becoming encrusted with dust. Clean the radiator and cooler only after the radiator has cooled to avoid cracking.

FOR SAFETY: When Servicing Machine, Wear Eye And Ear Protection When Using Pressurized Air Or Water.

Flush the radiator and the cooling system every 400 hours of operation, using a dependable cleaning compound.

ENGINE FAN BELT

The engine fan belt is driven by the engine crankshaft pulley and drives the alternator pulley. Proper belt tension is 9 to 10 mm (0.35 to 0.39 in) for a new belt and 10 to 11 mm (0.3 to 0.43 in) for a used belt with a force of 10 kg (22 lb).

Check and adjust the belt tension every 100 hours of operation.

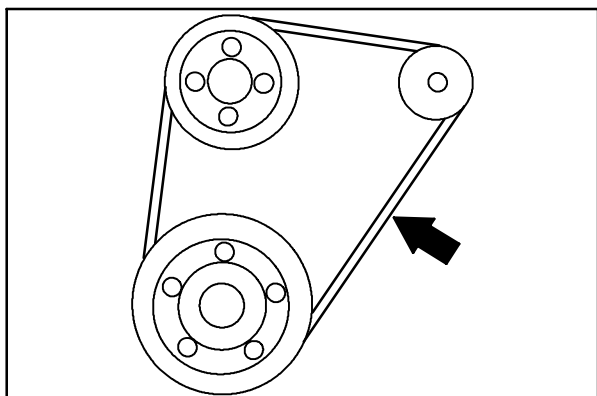
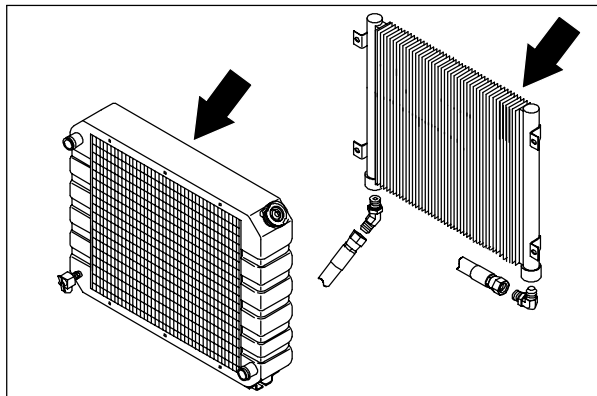
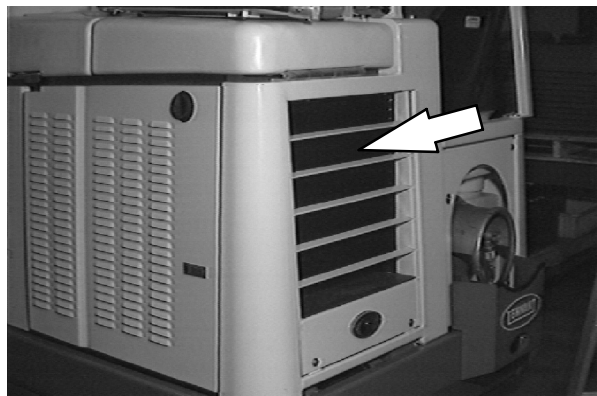
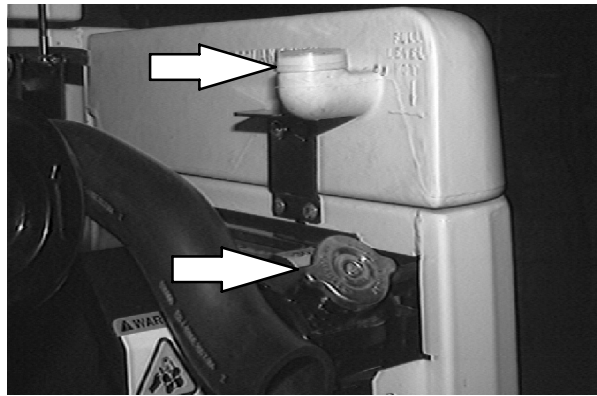

AIR INTAKE SYSTEM

AIR FILTER INDICATOR

The air filter indicator shows when to clean or replace the air filter element. Check the indicator daily. The indicator's red line will move as the air filter element fills with dirt. Do not clean or replace the air filter element until the red line reaches 5 kPa (20 in H₂O) and the "SERVICE WHEN RED" window is filled with red. The indicator's red line may return to a lower reading on the scale when the engine shuts off. The red line will return to a correct reading after the engine runs for a while.

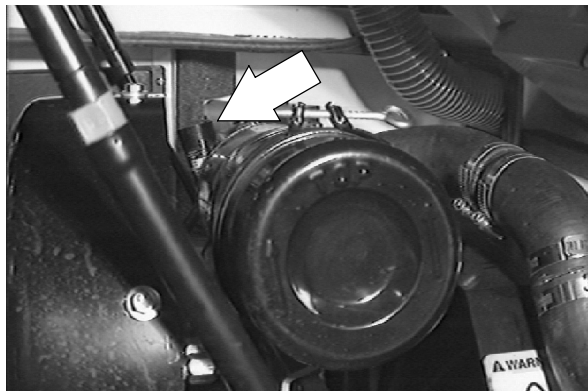

Reset the air filter indicator by pushing the reset button on the end of the indicator after cleaning or replacing the air filter element.

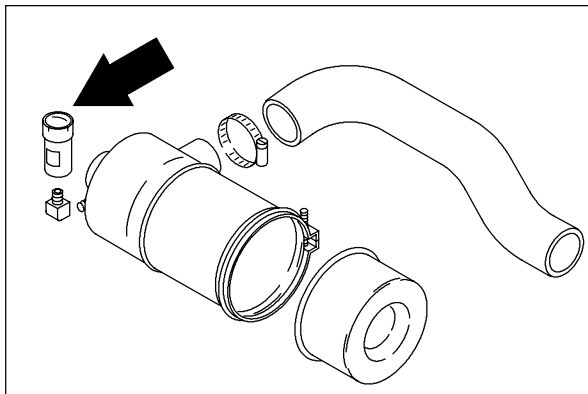

AIR FILTER

The engine air filter housing has a dust cap and a dry cartridge-type air filter element. Empty the dust cap daily. The air filter must be replaced whenever the filter element is damaged or when the air filter indicator shows a restriction. The air filters cannot be cleaned.

Machines with the heavy duty air filter option have a safety element. It is inside the standard element. Replace, do not clean this element after the regular element has been damaged or cleaned three times.

Replace the air filter element only when the air filter indicator shows restriction in the air intake system. Do not remove the air filter element from the housing unless it is restricting air flow.

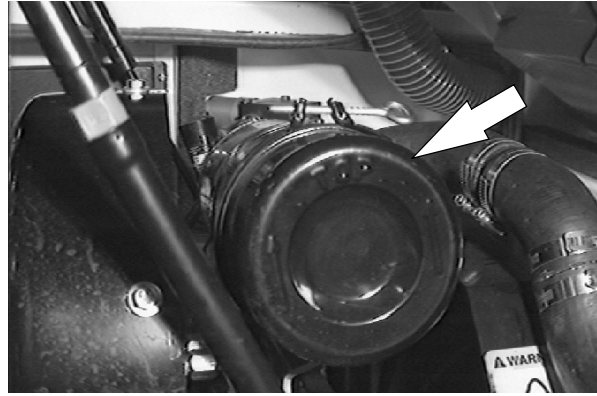

TO REPLACE AIR FILTER ELEMENT

1. Stop the engine and set the machine parking brake.

FOR SAFETY: Before Leaving Or Servicing Machine; Stop On Level Surface, Set Parking Brake, Turn Off Machine And Remove Key.

2. Open the left side and top engine access doors.
3. Unscrew the clamp ring on the filter assembly.
4. Remove the dust cap.
5. Empty the dust cap.
6. Remove the filter wing nut.
7. Gently pull the filter element out of the filter housing.
8. Clean the interior of the air cleaner housing with a damp cloth. Clean the element housing sealing surfaces.
9. Using an air hose, direct dry, clean air maximum 205 kPa (30 psi) up and down pleats on the inside of the filter. Do not rap, tap, or pound dust out of the element.

FOR SAFETY: When Servicing Machine, Wear Eye And Ear Protection When Using Pressurized Air Or Water.

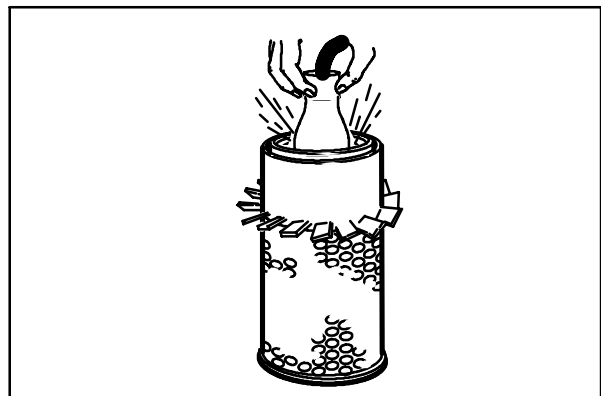
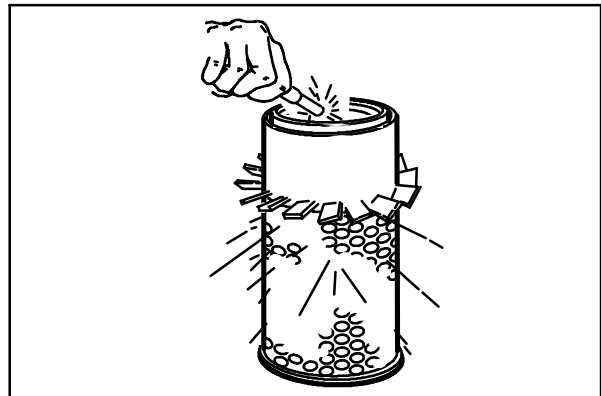

10. After cleaning the air filter element, inspect it for damage by placing a bright light inside. The slightest rupture requires replacement of the filter. Clean and inspect the seals on the ends of the element. They should be unbroken and flexible. *Remember to replace the element after cleaning it three times.*
11. Install the new or cleaned filter element so the fins on the element are at the intake end of the air cleaner. Be careful not to damage the fins. Make sure the element is seating evenly. Tighten the element wing nut.
12. Install the dust cap on the air filter housing with the arrows pointing up. Tighten the clamp ring to hold it in place. Check all intake hose connections for leaks or abrasions.
13. Reset the air filter restriction indicator.
14. Close the access doors.

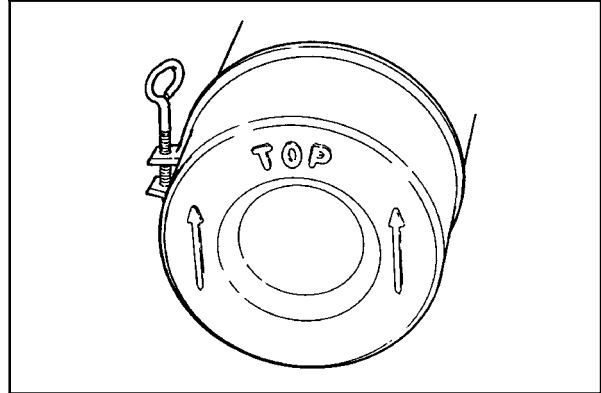

FUEL SYSTEM - GASOLINE

FUEL FILTERS

The fuel filter trap fuel contaminants. The filter is located on the fuel line going into the carburetor.

Replace the filter elements every 400 hours of operation.

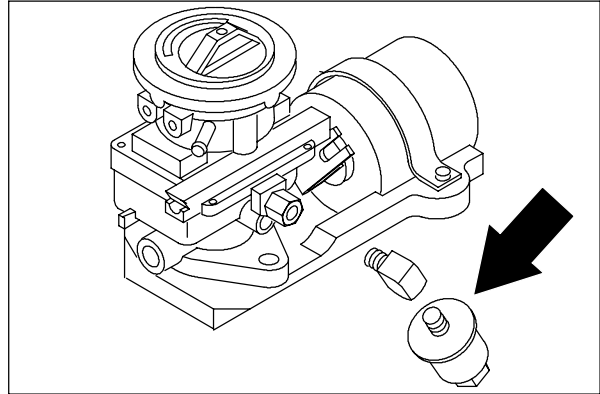
**CARBURETOR**

The carburetor has two basic adjustments. Those adjustments are idle fuel mixture and idle speed. Check and adjust idle fuel mixture and idle speed every 100 hours of operation.

FOR SAFETY: When Servicing Machine, Keep Flames And Sparks Away From Fuel System Service Area. Keep Area Well Ventilated.

The idle speed is controlled by a screw located on the side of the carburetor next to the throttle linkage. Increase the engine speed by turning the screw clockwise. Decrease the engine speed by turning the screw counter-clockwise. Proper idle speed is 950 ± 50 rpm with all accessories off.

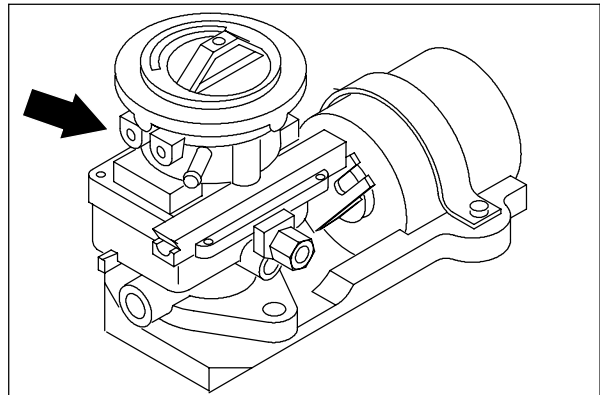

FUEL SYSTEM - LPG

The liquid withdrawal LPG fuel system has up of five components: the LPG fuel tank, pressure relief valve, fuel filter lock, vaporizer-regulator, and the carburetor.

Liquid LPG fuel flows from the LPG tank under its own pressure, to the pressure relief valve. Usually this valve is closed, preventing LPG fuel from escaping into the atmosphere. The valve opens to relieve pressure if the fuel pressure exceeds system limits. From the pressure relief valve, the liquid LPG fuel flows to the fuel filter lock.

The fuel filter lock filters unwanted tank scale and deposits out of the LPG fuel. The fuel filter lock also stops the flow of LPG fuel when the engine is not operating. The oil pressure switch controls the fuel filter lock. When the engine oil pressure is 35 kPa (5 psi) or greater, the oil pressure switch permits an electrical current to open the fuel filter lock which allows LPG fuel to flow on to the vaporizer-regulator. The oil pressure switch is bypassed when the engine is being started, allowing LPG fuel to flow.

The vaporizer section of the vaporizer-regulator converts the liquid LPG fuel into a gaseous LPG fuel. From the vaporizer section, the gaseous LPG fuel is sent to the primary regulator section of the vaporizer-regulator. The primary regulator section reduces the pressure of the LPG fuel. The secondary regulator section reduces the LPG fuel pressure to the level required by the carburetor. From the vaporizer-regulator, the LPG fuel is sent to the carburetor where it is finally metered into the air flow sent to the engine combustion chamber.

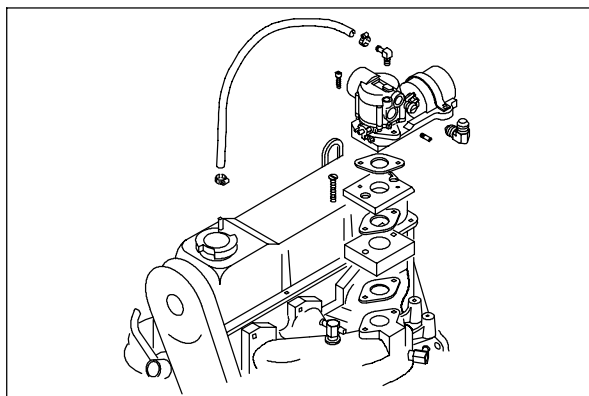
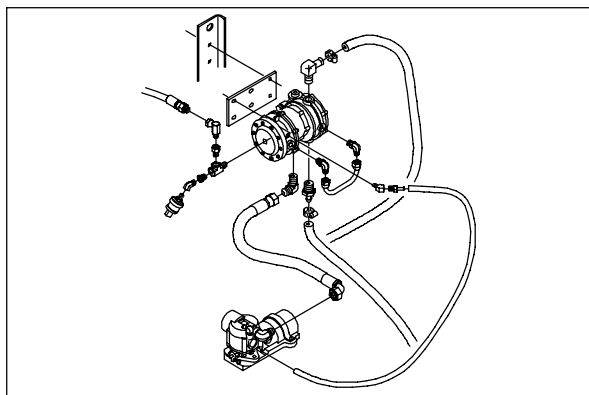
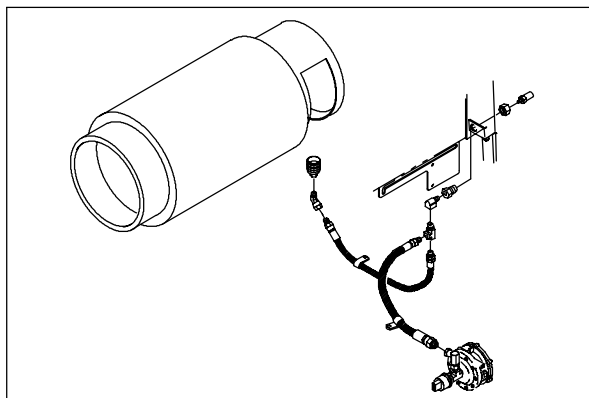

Never operate an LPG powered machine if the LPG fuel system is leaking, or if any component in the fuel system is malfunctioning. Operating the machine under either of these conditions may cause a fire or explosion.

Check for frosting. If frosting occurs on or near any LPG component, there is a possible LPG fuel leak or malfunctioning component.

To locate the leak, apply a soapy water solution to the suspected area. Watch for bubbles forming in this suspected area. This area may have an LPG fuel leak. Repair or replace the part. Use Loctite brand Stainless Steel PST thread sealant when reassembling. Aging or high humidity does not affect this epoxy-type sealant. Be sure to follow application directions and apply proper torque when reconnecting fittings. Never bypass safety components except to test. If they are defective, replace them before operating the machine. Frosting does not occur before the engine reaches operating temperature. Check after engine reaches operating temperature.

Check routings of all LPG hoses. Keep them away from sharp edges, exhaust manifolds, or other hot surfaces. Check for signs of abrasion or deterioration. Replace worn or damaged hoses.

FUEL TANKS

The LPG fuel tanks should be inspected for sharp dents, gouges, leaks, and broken protecting rings whenever the tanks are refilled. All tank valves must be inspected for leaks using a soap solution. Valves must also be checked for dirt, paint, or other debris in the valve openings. The following specific checks must also be made:

Filler Valve - Check the valve for proper functioning and the presence of the handwheel. Valve must be closed except during filling.

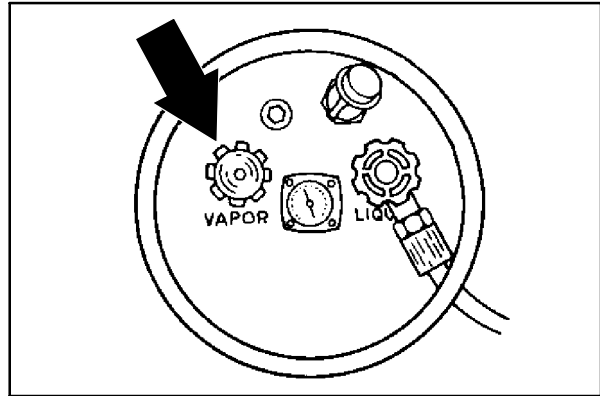

03485

Liquid Service Valves - Check the valve for proper functioning and presence of the handwheel. The valve must be closed except when in service.

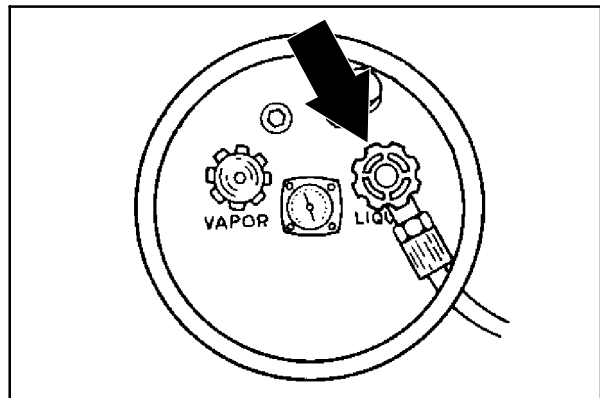

03485

Tank Service Valve Coupling - Check for proper functioning, thread condition, and damaged or missing washers or o-rings.

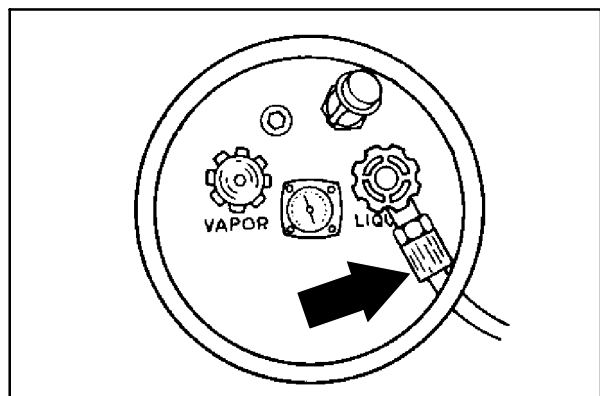

03485

Safety Relief Valve – Check for damage. Check for the presence of the relief valve elbow and the proper direction of the elbow. If the rain cap is missing, check for foreign matter and replace the rain cap. Do not tamper with the relief valve setting.

Magnetic Liquid Level Gauge – Check the operation against the maximum filling point as determined by weight.

An LPG fuel tank with any of the stated defects must be removed from service and be repaired or destroyed accordingly.

If an LPG fuel tank is damaged or leaking, it should be removed to a designated safe area. Do not attempt to make repairs to the tank, regardless of condition. Qualified personnel must make repairs or disposal.

The care an LPG fuel tank receives has a direct bearing on how long that tank can be used safely. LPG fuel tanks must not be dropped or dragged across any surface. To move LPG fuel tanks, use a hand truck or roll the tank on its foot ring while it is being held in a position slightly off the vertical.

Whether the storage is inside or outside, fuel tanks should not be stored near combustible materials or high temperature sources such as ovens and furnaces, since the heat may raise the pressure of the fuel to a point where the safety relief valves would function. Store the tanks in a way that if the safety relief valves do function, they will relieve vapor and not liquid.

Valves on empty tanks must be closed during storage and transportation.

Similar precautions should be taken in storing machines fitted with LPG fuel tanks. The machines may be stored or serviced inside buildings, provided there are no leaks in the fuel system and the tanks are not overfilled. While machines are being repaired inside a building, the shut-off valve on the tank must be closed, except when the engine has to be operated.

Changing the tank is a chance for the machine operator to carefully check over the tank, fittings, and the fuel lines and fittings. If abnormal wear is detected, report the findings to the appropriate personnel.

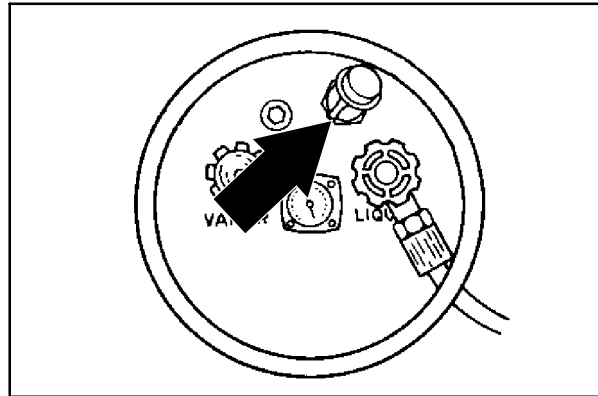

03485

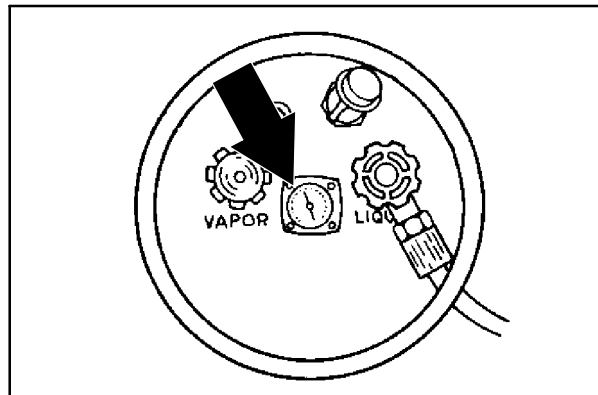

03485

TO CHANGE LPG FUEL TANK

1. Park the machine in a designated safe area.
2. Close the tank service valve.
3. Operate the engine until it stops from lack of fuel, then set the machine parking brake.

FOR SAFETY: Before Leaving Or Servicing Machine: Stop On Level Surface, Set The Parking Brake, Turn Off Machine And Remove Key.

4. Put on gloves and remove the quick-disconnect tank coupling.
5. Inspect the LPG fuel lines for wear or damage.
6. Remove the empty LPG fuel tank from the machine.
7. Check the tank for damage or wear.
8. Store the tank in a designated, safe area.
9. Select a filled LPG fuel tank and inspect it for damage or leaks.

NOTE: Make sure the LPG fuel tank matches the fuel system (liquid tank with liquid system).

10. Carefully put the LPG tank in the machine so that the tank centering pin enters the aligning hole in the tank collar.

NOTE: If you cannot line up the centering pin, make sure you have the correct LPG fuel tank and then adjust the pin locator in or out.

11. Fasten the tank hold-down clamp to lock the tank in position.
12. Connect the LPG fuel line to the tank service coupling. Make sure the service coupling is clean and free of damage. Also make sure it matches the machine service coupling.
13. Open the tank service valve slowly and check for leaks. Close the service valve immediately if an LPG leak is found, and tell the appropriate personnel.
14. If no leaks are found, the engine is ready to start.

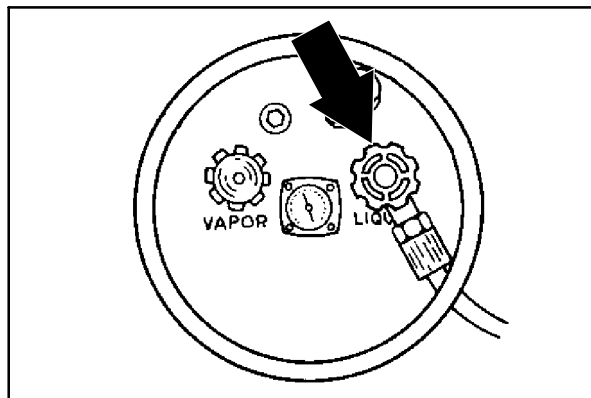

03485

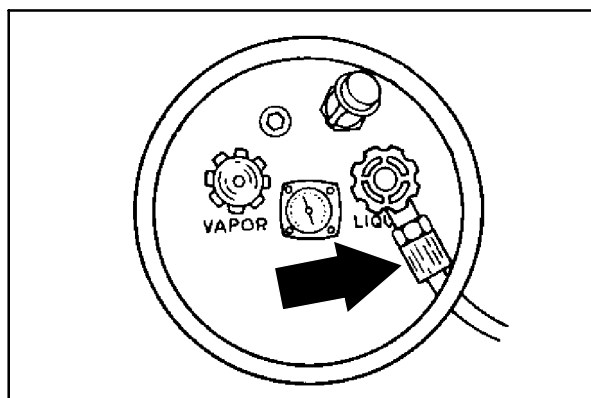

03485

FUEL FILTER LOCK

The fuel filter lock filters the LPG fuel. It also stops the flow of LPG fuel to the engine when the engine is not operating or when the engine oil pressure is less than 35 kPa (5 psi).

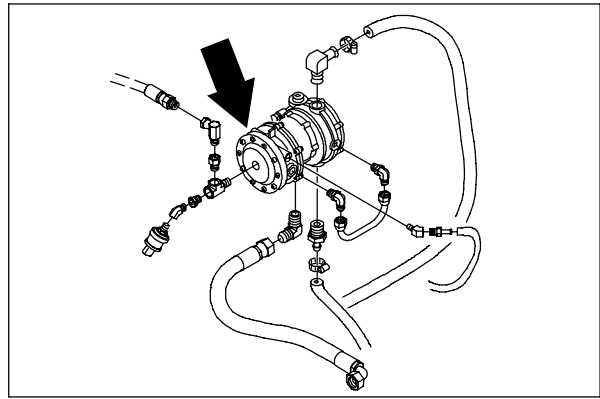
**VAPORIZER-REGULATOR**

The vaporizer-regulator. If any malfunction is found, completely disassemble the vaporizer-regulator. Clean all the parts in alcohol.

Inspect all the parts and replace where needed. Carefully reassemble the vaporizer-regulator with the seal repair kit. Check for proper operation.

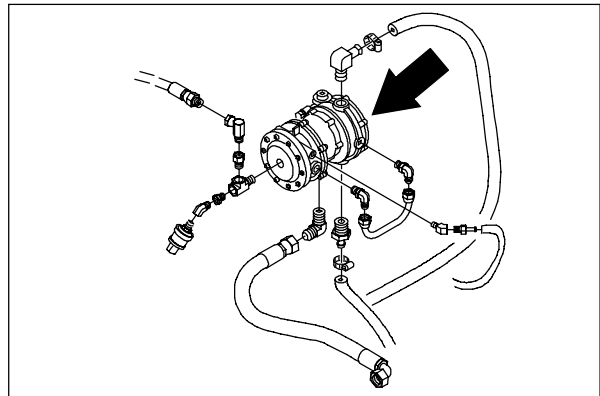
**CARBURETOR**

The carburetor. If any malfunction is found, completely disassemble the carburetor. Clean all the parts in alcohol.

Inspect all the parts and replace where needed. Carefully reassemble the carburetor with the seal repair kit.

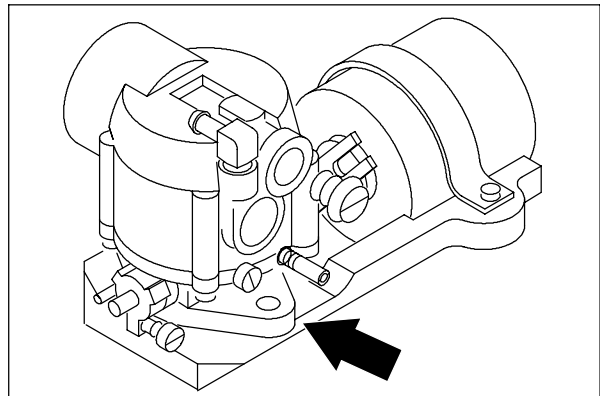
**OIL PRESSURE SWITCH**

The engine oil pressure switch requires no regular maintenance. Never bypass the oil pressure switch. The switch is a safety feature that prevents LPG fuel from flowing when the engine is not operating properly.

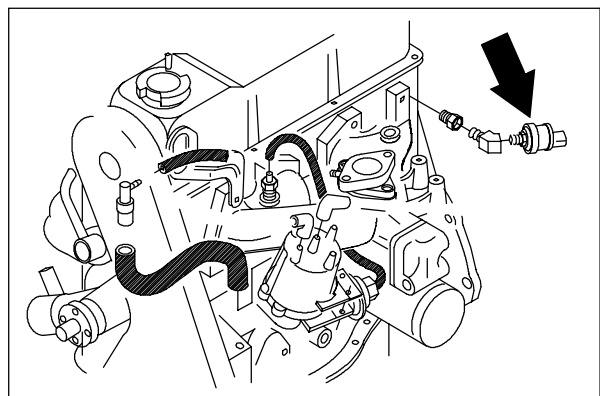

LPG FUEL TROUBLESHOOTING

| Problem | Cause | Remedy |
|-------------------------------------|--|---|
| Engine will not start | Out of fuel | Replace fuel tank with full one |
| | Service valve opened too quickly - check valve stopped fuel flow | Close service valve and reopen slowly |
| | Plugged fuel filter | Replace filter |
| | Kinked or restricted fuel line | Straighten or replace fuel line |
| | Engine out of tune | Tune-up engine |
| | Oil pressure switch failure | Replace oil pressure switch |
| | Fuel lock valve failure | Repair or replace fuel filter lock |
| | Vaporizer-regulator failure | Repair or replace vaporizer-regulator |
| Engine runs unevenly or lacks power | Wrong type of fuel tank - vapor withdrawal tank | Replace vapor withdrawal tank with liquid withdrawal tank |
| | Plugged fuel filter | Replace filter |
| | Kinked or restricted fuel line | Straighten or replace fuel line |
| | Engine out of tune | Tune-up engine |
| | Restricted air filter | Clean or replace air filter element |
| | Vaporizer-regulator out of adjustment | Adjust vaporizer-regulator |

GOVERNOR

The electronic governor controls the engine speed. The governor consists of an ignition control assembly, a control box, and an actuator mounted to the carburetor. The ignition control assembly and control box regulate the actuator, which in turn controls the throttle.

The electronic governor is factory set and is not user serviceable.

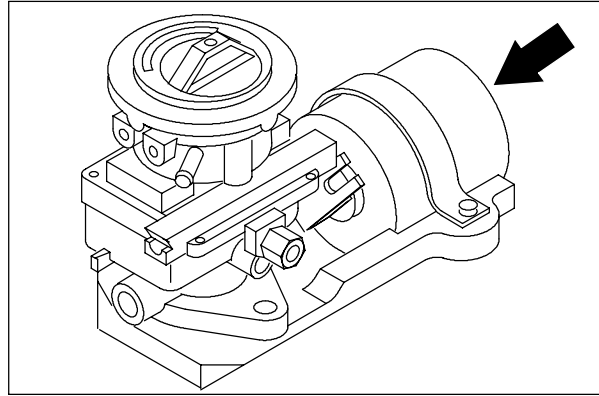

TO ADJUST GOVERNOR CONTROL BOX

FOR SAFETY: Before Leaving Or Servicing Machine: Stop On Level Surface, Set The Parking Brake.

1. Raise the rear of the machine until the drive wheel is off the floor.

FOR SAFETY: Block machine tires before jacking machine up. Jack machine up at designated locations only. Block machine up with jack stands.

2. Start the engine and warm to operating temperature.
3. Move the speed switch to idle, all accessories off.
4. Move speed switch to fast position.
5. **FOR ANALOG CONTROLLER:**
If engine speed surges occur, turn the surge adjustment screw (located on back of governor control box under hole plug) counterclockwise one-eighth of a turn.

Repeat until engine surges do not occur.

Replace the hole plug if removed for adjustment.

6. **FOR DIGITAL CONTROLLER:**
Follow the instructions on the *Digital Controller Setup* diagram.

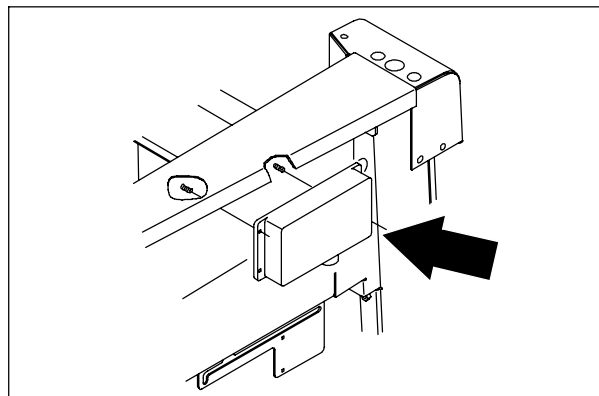
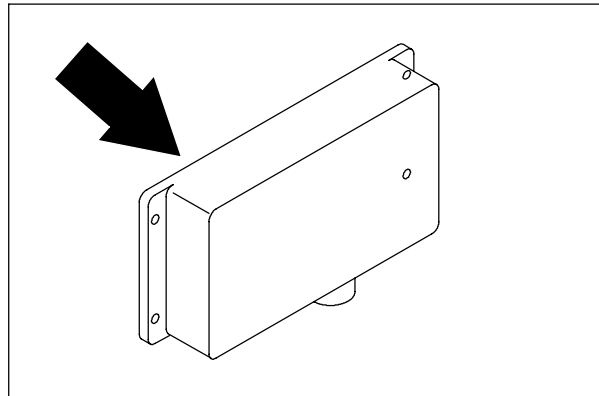

Set DIP switches according to controller label, before installing to controller.

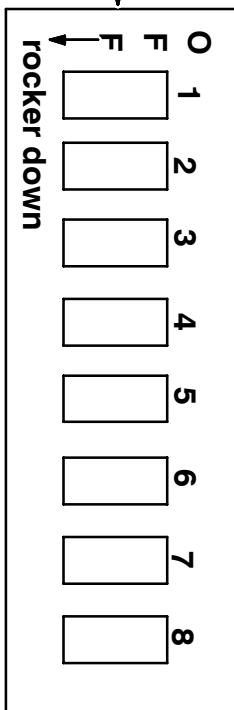

Digital Controller
p/n 374763

| Controller Set-Up: | | DIP Switch Settings: | | | | | |
|--------------------------|--|----------------------------------|-----------|-----|-----|-----|-----|
| Program Number | Machine Model | Switch number starting from left | | | | | |
| | | #1 | #2 | #3 | #4 | #5 | #6 |
| #1 | 355/6500/6550/8200/8210/7400 Gas/LP | ON | OFF | OFF | OFF | OFF | OFF |
| #2 | 6550/7400/8200/8210 Diesel w/ SJ actuator (linear) | OFF | ON | OFF | OFF | OFF | OFF |
| #3 | 355/6500/6550/7400 Diesel w/ SF (rotary) actuator | ON | ON | OFF | OFF | OFF | OFF |
| #4 | 800/810 Gas | OFF | OFF | ON | OFF | OFF | OFF |
| #5 | 800/810 LP | ON | OFF | ON | OFF | OFF | OFF |
| #6 | 800/810 550/1550 Diesel | OFF | ON | ON | OFF | OFF | OFF |
| #7 | 8400/8410 Gas | ON | ON | ON | OFF | OFF | OFF |
| #8 | 8400/8410 LP | OFF | OFF | OFF | ON | OFF | OFF |
| #9 | 8400/8410 Diesel | ON | OFF | OFF | ON | OFF | OFF |
| #10 | 6500II LP / Gas | ON | ON | OFF | ON | OFF | OFF |
| #11 | 6500II/6550II Diesel | OFF | OFF | ON | ON | OFF | OFF |
| #12 | 800/810 Diesel – 2 spd | ON | OFF | ON | ON | OFF | OFF |
| #13 | 800/810 Gas - 2 spd | OFF | ON | ON | ON | OFF | OFF |
| #14 | 800/810 LP – 2 spd | ON | ON | ON | ON | OFF | OFF |
| #15 | 355/6500/6550/8200/8210/7400 Gas/LP – special 2 spd | OFF | OFF | OFF | OFF | ON | OFF |
| #16 | 6550/7400/8200/8210 Diesel w/ SJ actuator (linear) sp. 2 spd | ON | OFF | OFF | OFF | ON | OFF |
| Special DIP Settings: ↓ | | Special DIP Settings: ↓ | | | | | |
| Engines with Distributor | | Altitude compensation | | | | | |
| #7 | Distributor | #8 | RPM added | | | | |
| ON | Distributor | ON | 200 rpm | | | | |
| OFF | Non Distributor (DIS) | OFF | 0 rpm | | | | |

Gain pot and Trouble shooting LED can be seen through here:
←

DIGITAL CONTROLLER SET-UP

GOVERNOR TROUBLESHOOTING

1. The first step in this troubleshooting is to disconnect the throttle linkage at the carburetor and work the throttle at the carburetor by hand.

If you can run the engine by hand and it works with no problems, go to step two.

If the problem continues, it is not with the governor, it is with the ignition signal, fuel systems or the engine itself.

2. The idle speed is the governor position. This is 1100 - 1500 RPM and is controlled by the governor, *NOT THE IDLE STOP SCREW ON THE CARBURETOR!* In order to adjust the idle mixture and (SHUTOFF SPEED) on the carburetor, either of the wires on the actuator box must be disconnected. After warming up the engine, adjust the shutoff speed to 850 ± 25 RPM and adjust the idle mixture for optimum idle quality. After doing this, shut off the engine and reattach the wires to the actuator. It is important that the shutoff speed not be set any higher than 900 RPM or the engine will (diesel) when it is shut off. Again, the idle speed screw on the carburetor does not control the start/idle speed of a correctly setup engine.

3. Fuel System

A common problem that has been encountered on LPG machines is a restricted fuel hose (a clogged fuel filter can have the same effect).

If the governor opens the carburetor wide open and the engine loses speed, the problem is not in the governor. The fuel system is at fault. The purpose of the governor is to open the carburetor and to bring the engine to set RPM's depending on where you have the speed control switch set at.

4. System Grounds

The wire harness grounds are routed to the stud on the alternator, and from there, a separate cable is routed to the bolt on the bell housing where the battery cable is attached.

If a bad ground is present, the engine will tend to run over speed.

The machine must have good grounds throughout from the battery cable to the control box.

The battery cable must be clean and tight.

The actuator is internally isolated and does not require that the cable be grounded.

5. Start-Up Check

With the throttle switch in the engine start position, turn the ignition switch to the on position. The actuator should cycle the carburetor lever once.

NOTE: A cycle is to move from the off or idle position to the open position and then return to the off or idle position.

If this does not happen, the power wiring to the control box is probably at fault or the control box is faulty. IT IS RARE TO HAVE A FAULTY CONTROL BOX, so proceed with the following voltage checks BEFORE REPLACING IT.

6. Throttle Control Switch Check

If the engine doesn't respond to the throttle switch control:

- a. With the engine running, disconnect Wire 86, purple wire, at the actuator.
- b. Connect a jumper wire from the battery terminal on the starter to the terminal where you removed Wire 86, purple wire, from the actuator.

The engine should come up to operating speed. If the engine comes up to speed, replace the throttle control switch.

- a. Hunts at running speed with the accessories off.

- b. Responds very sluggishly to switch changes, an adjustment change in the control box may be necessary.

FOR ANALOG CONTROLLER:

Cut and remove the RTV seal on the back of the box.

A slight adjustment of the surge screw may be necessary to correct the conditions mentioned above. Turn the screw approximately 2° at a time and wait for 30 seconds to verify the change. Be careful. Only a slight change is necessary, and the “pot” can be broken if too much force is used.

After the control throttle response is achieved, verify that the operating speeds are correct and adjust, if necessary. After the speeds are reset, the surge screw may have to be readjusted.

In general, if a new box is being installed, a gasoline-equipped machine may require that the sensitivity be reduced slightly.

When the sensitivity is adjusted, the run speed should not be affected. If the adjustment is too great, the start speed will be affected. Verify that the start speed is correct.

If too much sensitivity is adjusted in, the engine will either hunt in a no load condition or over speed severely when the speed switch is actuated.

The engine speed should not drop off, but you can have the three hunts of the engine.

If, for some reason, the sensitivity adjustment became grossly maladjusted, a good starting point can be obtained by rotating the pot fully counterclockwise and then back clockwise 45°.

After the adjustments are made and verified, reassemble the back plate and reseal the plate with a bead of RTV to keep dust and moisture out of the box.

FOR DIGITAL CONTROLLER:

See *To Adjust Governor Control Box* section of this manual.

IGNITION SYSTEM

SPARK PLUGS

Clean or replace, and set the gap of the spark plugs every 400 hours of operation. A wire gauge is best for checking the spark plug gap. A flat gauge should not be used unless the electrode surfaces have been dressed with a small file to get parallel surfaces between the center and side electrode. Set the spark plug gap by bending the side electrode. All spark plugs, new or used, should have the gaps checked and reset if necessary.

The proper spark plug gap is 1 mm (0.040 in).

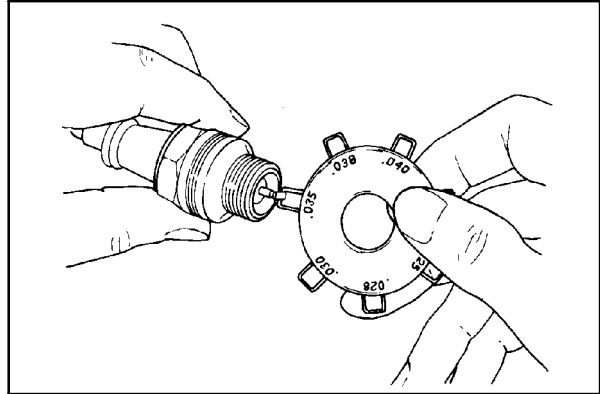

TO REPLACE SPARK PLUGS

FOR SAFETY: Before Leaving Or Servicing Machine: Stop On Level Surface, Set The Parking Brake.

1. Open the engine cover and side door.
2. Pull the plug wires off the spark plugs.

NOTE: Before spark plugs are removed; clean any dirt or grease that has accumulated around the base of the spark plug.

3. Remove the spark plugs from the engine cylinder head.
4. Clean the spark plug seat in the cylinder head.
5. Use a new seat gasket and screw the plug in by hand.
6. Tighten the spark plugs with a socket wrench of the correct size.

ENGINE IGNITION TIMING

The engine timing should be set at 10° BTDC with the throttle set in the idle position.

TIMING BELT

Check the engine timing belt every 800 hours of operation, and replace the engine timing belt every 1600 hours of operation.

CYLINDER HEAD

A three-stage torque procedure should be used when reassembling the cylinder head. Tighten the cylinder head bolts seasonally. See Ford LRG 2.5 Engine Service Manual at the end of this section.

VALVE TAPPET CLEARANCE

The valve tappet clearance must be checked and adjusted if necessary every 400 hours of operation. See Ford LRG 2.5 Engine Service Manual.

Clean the crankcase ventilation hoses, tubes, and fittings and replace the PCV valve every 400 hours of operation.

CRANKCASE VENTILATION SYSTEM

Replace the PCV valve every 400 hours of operation. Clean the crankcase ventilation hoses, tubes, and fittings every 800 hours of operation.

INTAKE MANIFOLD

Tighten the intake manifold bolts or nuts every 800 hours of operation. They are tighten in a two step sequence. Torque the M8 bolts or nuts to 7 to 9.5 Nm (5 to 7 ft lb) in the first step, and 19 to 28.5 Nm (14 to 21 ft lb) in the second step of torquing.

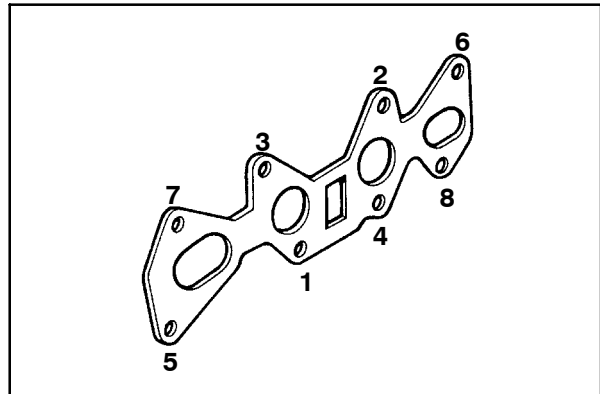

TO CHANGE ENGINE TIMING BELT

FOR SAFETY: Before Leaving Or Servicing Machine; Stop On Level Surface, Set Parking Brake, Turn Off Machine And Remove Key.

1. Disconnect the battery cables from machine.
2. Open the engine cover and side door.
3. Remove the engine spark plugs.

NOTE: Make sure the timing pointer on the timing belt cover is lined up with the "O" mark on the crank shaft damper before removing the timing belt.

4. Loosen the engine alternator and remove the V-belt.

NOTE: If the engine is equipped with a smaller top timing belt cover; it needs to be removed before the larger timing belt cover can be removed.

5. Remove the three M6 hex screws and nyloc nuts holding the smaller top cover to the engine. Remove and retain the smaller cover.
6. Remove the crankshaft damper pulley.
7. Pull the belt guide off the end of the crankshaft where the damper was removed.
8. Remove the five hex screws holding the large timing belt cover to the engine. Remove and retain the large cover.

NOTE: The tension on the timing belt needs to be released before the belt can be removed.

9. Loosen the belt tensioner adjustment screw and release the tension on the timing belt. Once the tension is released, re-tighten the tensioner adjustment screw.

NOTE: A special tension release tool is available from FORD. The part number is T74P-6254-A. A small pry bar may be used in place of this tool.

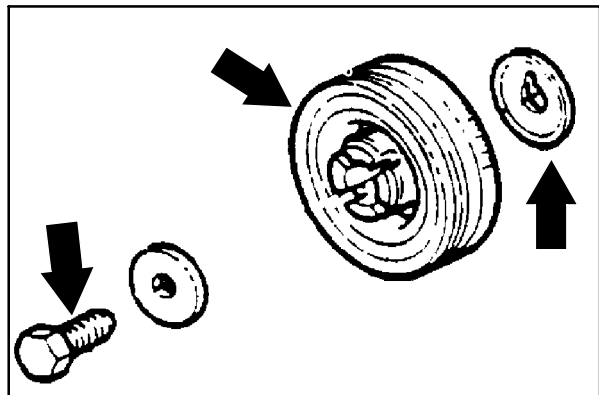
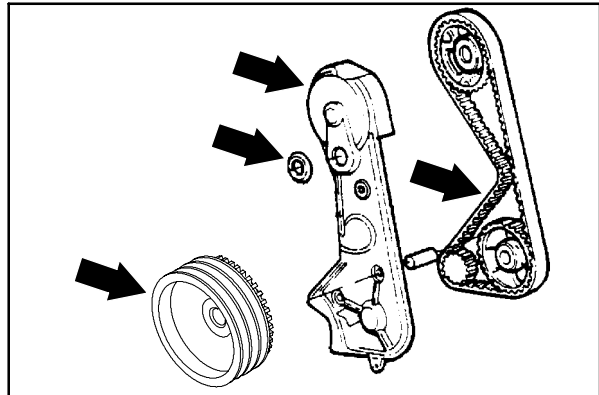
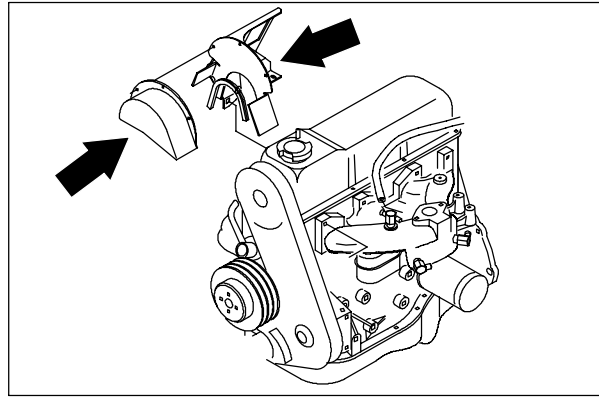

10. Remove the old timing belt from the engine.
11. Before installing a new timing belt, make sure the camshaft sprocket timing mark lines up with the timing pointer on the engine.
12. Remove the distributor cap and set the distributor rotor to number 1 firing position by turning the auxiliary shaft sprocket. Reinstall the distributor cap.
13. Install the new timing belt over the crankshaft sprocket and then counterclockwise over the the auxiliary and camshaft sprockets. Align the belt fore and aft on each sprocket.
14. Loosen the tensioner adjustment bolt to allow the tensioner to move against the belt.
15. Rotate the crankshaft two complete turns in normal rotation to remove the slack from the belt.
16. Re-check the alignment of the timing marks.
17. Reinstall the belt guide and damper to the crankshaft.
18. Reinstall the timing belt cover and the five hex screws.
19. Reinstall the small, top cover on the timing belt cover. Hand tighten the three M6 hex screws and nyloc nuts.
20. Reinstall the spark plugs.
21. Reinstall the alternator V-belt, pull the alternator to tension the belt, tighten the alternator mount bolts.
22. Reconnect the battery cables. Start the engine and check the timing. The timing should be set at 10 degrees BTDC with the engine at idle speed.

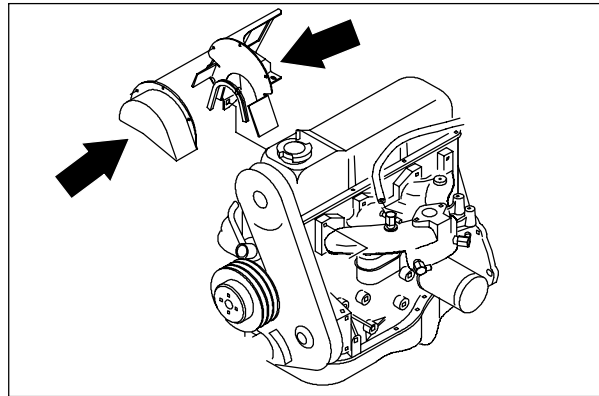
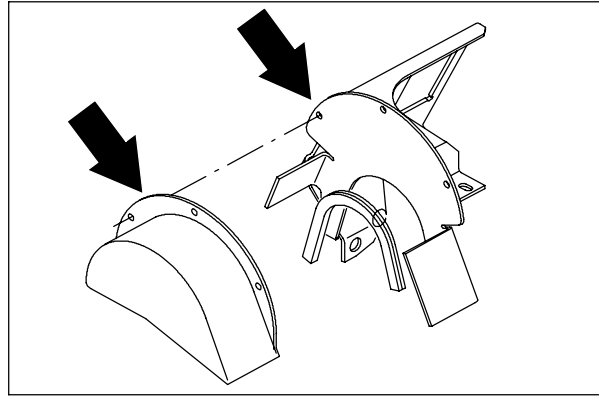

TO REPLACE ALTERNATOR

FOR SAFETY: Before Leaving Or Servicing Machine; Stop On Level Surface, Set Parking Brake, Turn Off Machine And Remove Key.

1. The solution and recovery tanks must be removed from machine to replace the alternator. See TO REMOVE SOLUTION TANK FROM MACHINE instructions in the SCRUBBING section of this manual.
2. Disconnect the battery cables from the battery.
3. Open the engine cover and side door.
4. Disconnect the wires on the back of the alternator.
5. Remove the 0.31 in. hex screw holding the top of the alternator to the upper mount bracket. Push the alternator toward the engine and remove the v-belt.
6. Remove the 0.38 in. hex screw and nyloc nut holding the bottom of the alternator to the lower mount bracket.
7. The alternator can now be removed. Bring the alternator forward and out through the area of the solution tanks.
8. If the new or rebuilt alternator needs a drive pulley; remove the pulley from the old alternator by holding pulley from turning and using an impact wrench to remove hex nut.
9. Install pulley, washer, and hex nut on the new alternator. Hand tighten the nut with an impact wrench.
10. Install the new alternator back in the machine. Align the bottom hole in the alternator with hole in the lower mount bracket. Reinstall the 0.38 in. hex bolt, washer, and sleeve. Leave loose for now.
11. Place the v-belt back on the alternator pulley.

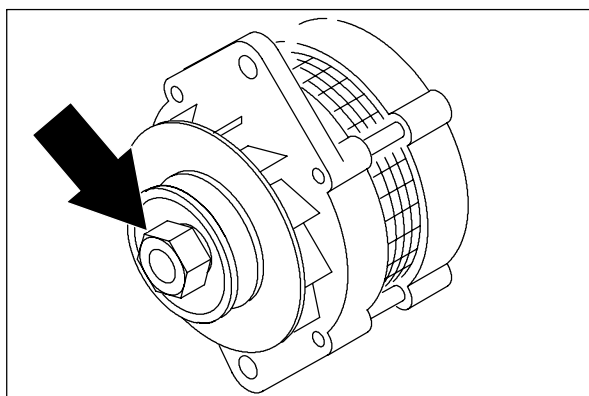
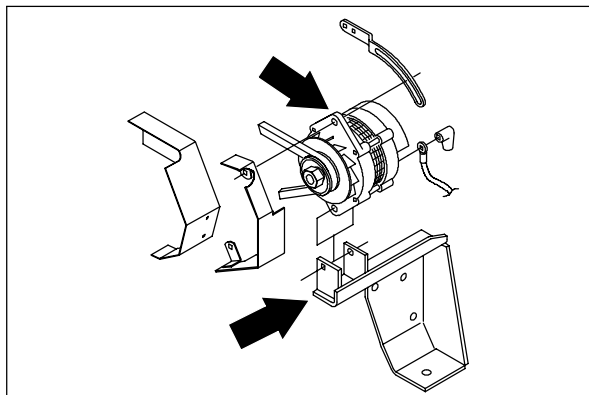
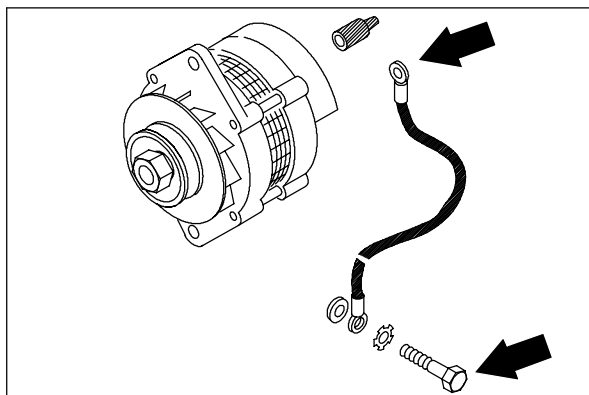
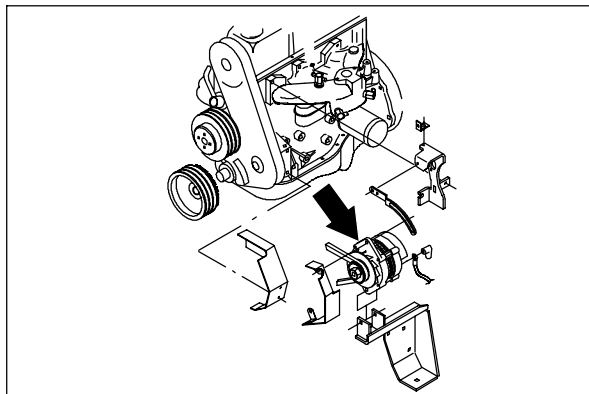

12. Reinstall the 0.31 in. hex screw in the top hole of the alternator through the upper mounting bracket. Pull alternator toward the outside of machine to tighten belt. Tighten the hex screw to 18 - 24 Nm (13 - 18 ft lb).
13. The engine fan belt is driven by the engine crankshaft pulley and drives the alternator pulley. Proper belt tension is 9 to 10 mm (0.35 to 0.39 in) for a new belt and 10 to 11 mm (0.39 to 0.43 in) for a used belt with a force of 10 kg (22 lb).
14. Tighten the bottom 0.38 in. hex screw to 31 - 40 Nm (27 - 35 ft lb).
15. Reconnect the wires to the back of alternator. See the schematic in the ELECTRICAL section.
16. Reconnect the battery, start the engine, and check for proper operation of the alternator.

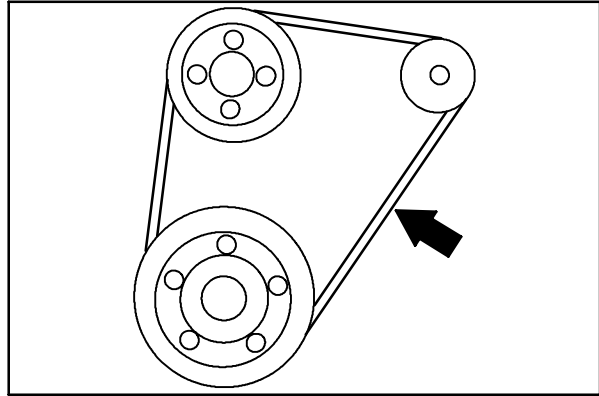

TO REPLACE STARTER

FOR SAFETY: Before Leaving Or Servicing Machine; Stop On Level Surface, Set Parking Brake, Turn Off Machine And Remove Key.

1. Remove all three scrub brushes.
2. If the machine will start, activate the scrub mode to lower the scrub head. Shut off the engine. If the machine will not start, place a drain pan under the middle and left hand scrub brush motors. Loosen the hydraulic hoses at the cylinder rod end fittings. Push the two scrub heads all the way down and block them in this position using a piece of wood. Re-tighten the two hydraulic hoses.
3. Disconnect the battery cables from the battery.
4. Remove the side brush so it will not get damaged when the rear of the machine is raised.
5. Raise the rear of machine using a hoist or floor jack.

FOR SAFETY: Block machine tires before jacking machine up. Jack machine up at designated locations only. Block machine up with jack stands.

6. The starter must be accessed from under the machine. Go under from the engine side.
7. The hardware holding the positive battery cable and starter wires to the starter is difficult to reach when its bolted in the engine. Remove the three M10 hex screws holding the starter to the engine. Use a 17 MM thin wall socket and swivel on the top screw. Tip the starter down and remove the hardware holding the cable and wires to starter.

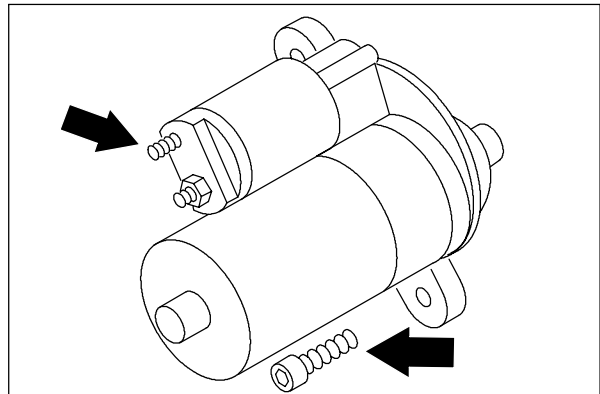
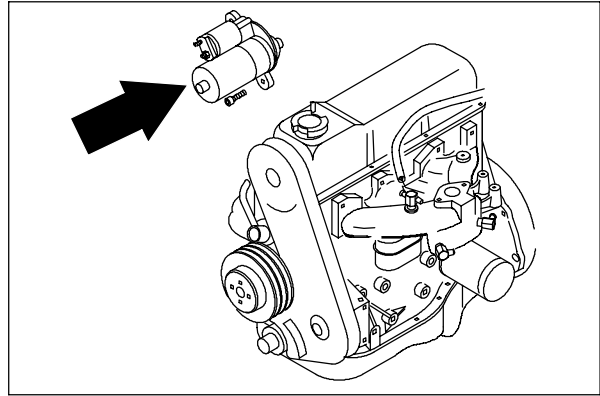

8. Swing the rear squeegee all the way to the left and slide the starter out through the space between the oil pan and the squeegee link plate.
9. Bring the new starter under machine and reconnect positive battery cable and starter wires to it. See the schematic in the ELECTRICAL section. Hand tighten the hardware.
10. Position the new starter, with wires connected, back in the bellhousing. Align the holes and reinstall the three M10 hex screws. Tighten to 37 - 40 Nm (26 - 34 ft lb). Use a 17 MM thin wall socket and swivel on the top screw.
11. Remove the wood blocks from the middle and left hand scrub heads. Remove the jack stands, lower the machine, and reinstall the side brush.
12. Reconnect battery cables to battery, start the engine, raise the scrub head and reinstall the three scrub brushes.

TO REMOVE ENGINE

FOR SAFETY: Before Leaving Or Servicing Machine; Stop On Level Surface, Set Parking Brake, Turn Off Machine And Remove Key.

1. Remove the battery cables from the battery.
2. Remove the engine cover and side door.
3. Drain the radiator.
4. Drain the engine oil.
5. Remove the vacuum fan hose, squeegee hose, and the air cleaner tube.
6. Remove the air cleaner assembly from the mounting bracket.
7. Disconnect and plug the hydraulic hoses on the scrubber vacuum fan motor.

NOTE: Observe hydraulic cleanliness requirements when opening hydraulic lines.

8. Remove the scrubber vacuum fan assembly.
9. Remove the vacuum fan/air cleaner mount bracket from the engine.
10. Remove the radiator hoses from the engine.
11. Disconnect the exhaust pipe at the engine manifold.
12. Disconnect the main electrical wire harness from all engine components and remove the clamps holding it to the engine. Place the harness out of the way.
13. Disconnect the engine ground strap from the right rear of the bellhousing.
14. On a **GAS** machine; disconnect the fuel line at the fuel pump. On an **LPG** machine; disconnect line from the lpg tank at the fuel lockoff / vaporizer assembly.

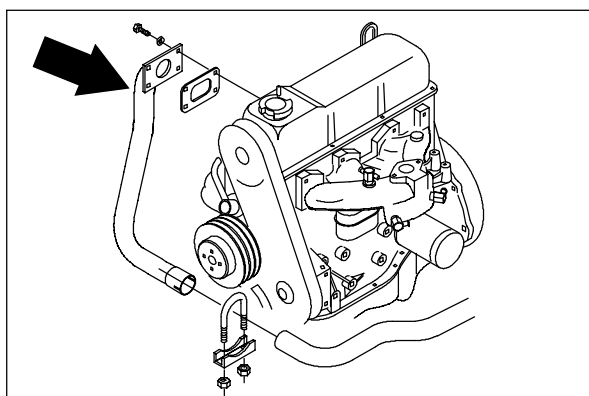
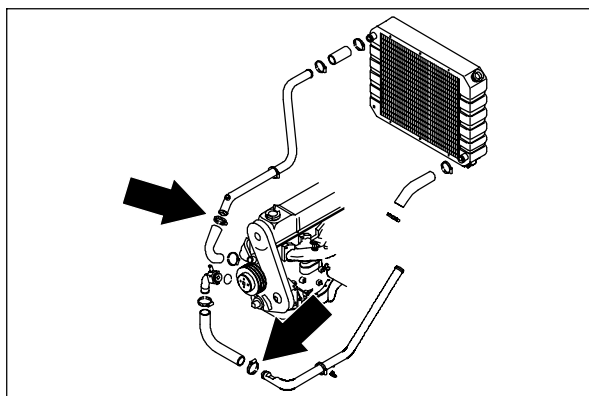
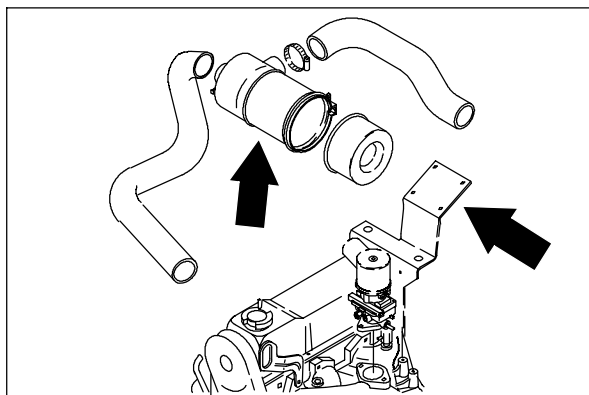
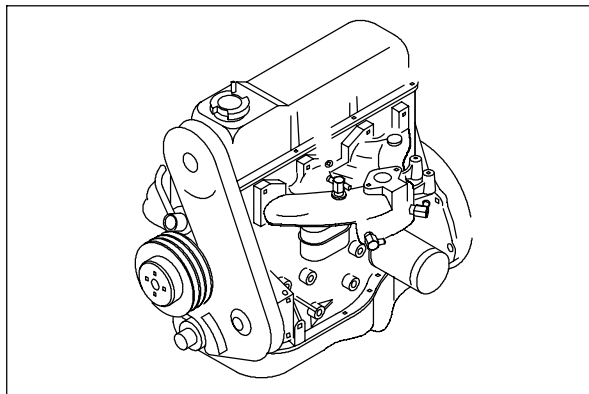

15. On an **LPG** machine; remove the two coolant and two fuel lines connected to the lockoff / vaporizer assembly.
16. Remove the lockoff/vaporizer assembly from the machine.
17. Remove the left rear grill panel for access to the hydraulic pump assemblies.
18. Remove the two M12 hex screws holding the load sensing / propel pump assembly to the flywheel housing.
19. Pull the load sensing / propel pump assembly back and out of flywheel housing.
20. Using an overhead hoist; hook a chain through the two pick-up points on engine. Put a slight amount of tension on the chain.
21. Remove the four M12 hex screws holding the motor mounts to the rubber isolators.
22. The engine can now be carefully lifted out.

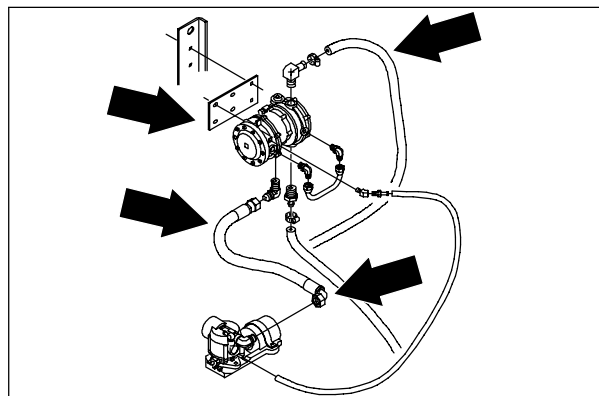
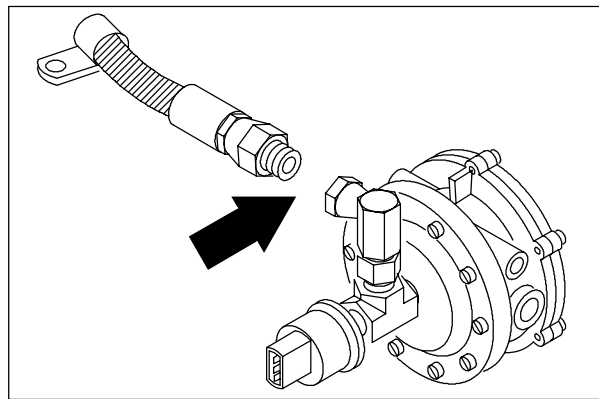
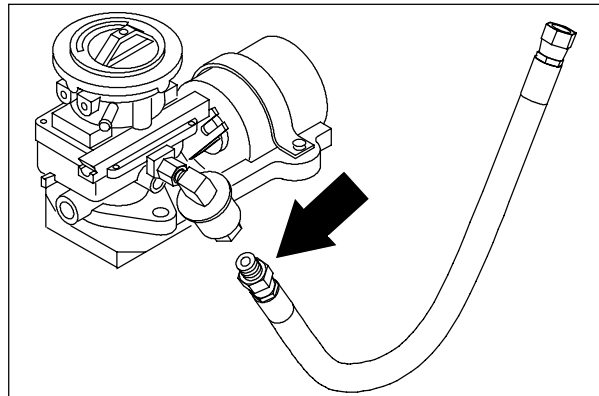
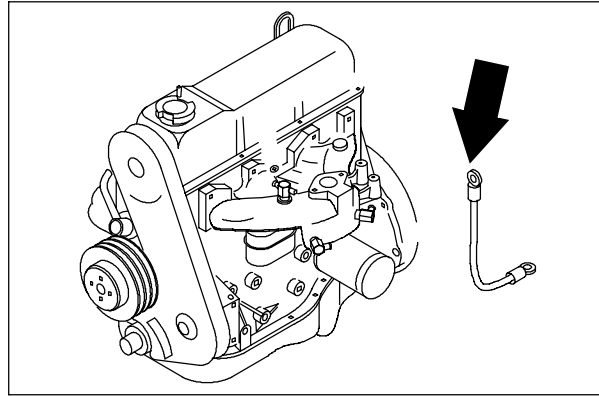

TO INSTALL ENGINE

FOR SAFETY: Before Leaving Or Servicing Machine; Stop On Level Surface, Set Parking Brake, Turn Off Machine And Remove Key.

1. Hook a chain through the two pick-up points on the engine. Use an over head hoist to lift the engine in the engine compartment.
2. Carefully lower the engine assembly down on the motor mounts.

NOTE: Make sure the hoses, wire harness, exhaust pipe, and load sensing pump are pulled back out of the way when lowering the engine assembly in place.

3. Reinstall the M12 hex screws in the four engine motor mounts. Tighten to 64 – 83 Nm (50 – 60 ft lb).
4. Reconnect the ground cable from the bellhousing to the machine frame.
5. Reinstall load sensing pump back in the bellhousing. Reinstall the M12 hex screws. Tighten to 64 – 83 Nm (50 – 60 ft lb).

NOTE: Make sure the splines on pump line up with splines in coupler when installing pump.

6. Reinstall exhaust pipe back on the engine manifold. Reinstall the four M10 hex screws. Tighten to 52 – 67Nm (39 – 51 ft lb).

NOTE: Make sure the steel gasket is in place when installing exhaust pipe.

7. Reconnect the fuel lines.
8. On an **LPG** machine; reinstall the lockoff/vaporizer assembly on the machine.
9. On an **LPG** machine; reconnect the two coolant and two fuel lines to the lockoff/vaporizer assembly.

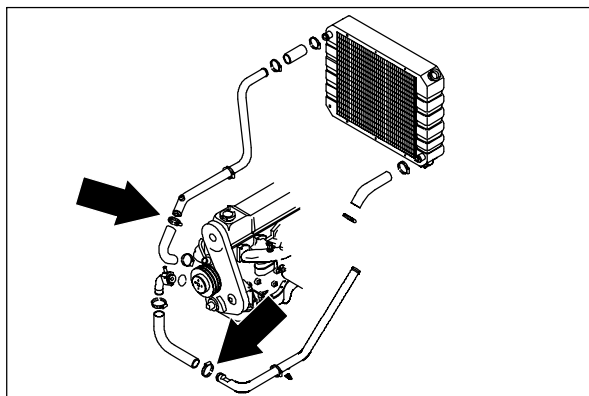
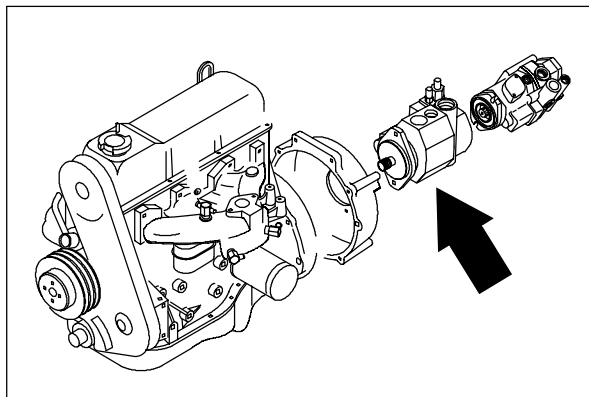
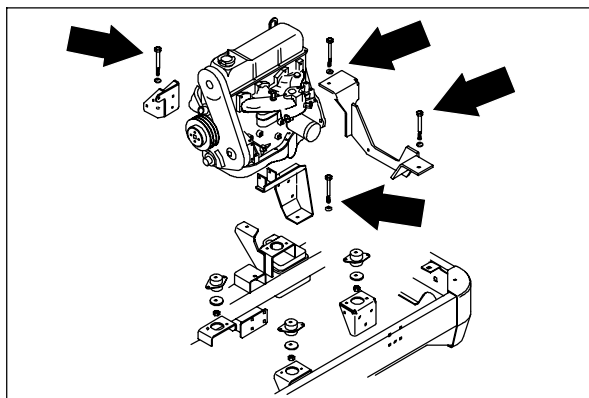
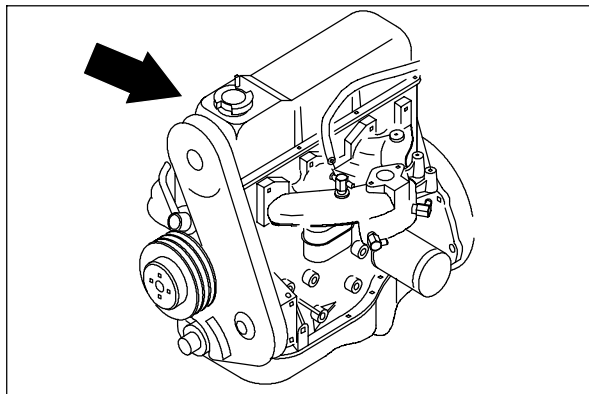

10. Fill the engine with proper grade of motor oil.
11. Reconnect wire harness to the engine components: alternator, starter, governor actuator, oil switch, temperature sender, distributor, and ignition module.
12. Reinstall the radiator hoses to engine and fill the radiator with coolant.
13. Reinstall the vacuum fan/air cleaner mount bracket to bellhousing. Reinstall the two M10 hex screws and tighten to 37 - 48 Nm (26 - 34 ft lb).
14. Reinstall the vacuum fan assembly to the mount bracket. Reinstall the three M10 hex screws, six washers, and three nyloc nuts. Tighten to 34 - 44 Nm (24 - 28 ft lb).
15. Reconnect the hydraulic hoses to the scrubbing vacuum fan motor. See the schematic in the HYDRAULICS section.
16. Reinstall the air cleaner assembly.
17. Reinstall the air cleaner tube, squeegee vacuum hose, and scrubber vacuum fan hose.
18. Reinstall the left rear grill panel to the machine. Reinstall the two M8 hex screws and washers. Tighten to 18 - 24 Nm (15 - 20 ft lb).
19. Reinstall the engine cover and side door.
20. Reconnect the battery cables to the battery.
21. Jack up the rear of the machine.

FOR SAFETY: Block machine tires before jacking machine up. Jack machine up at designated locations only. Block machine up with jack stands.

22. Start the engine and check for any leaks.

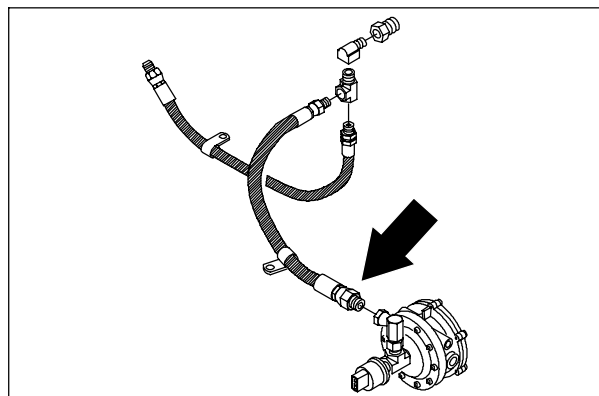
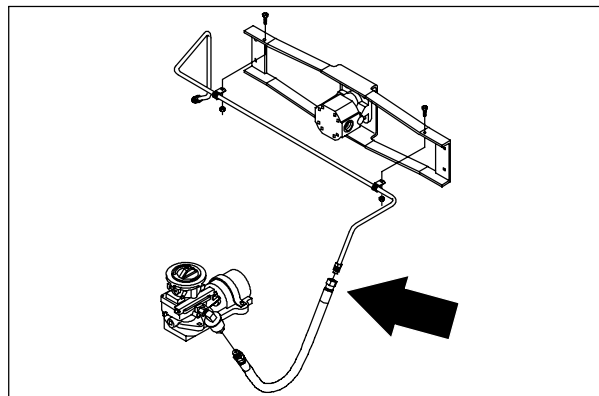
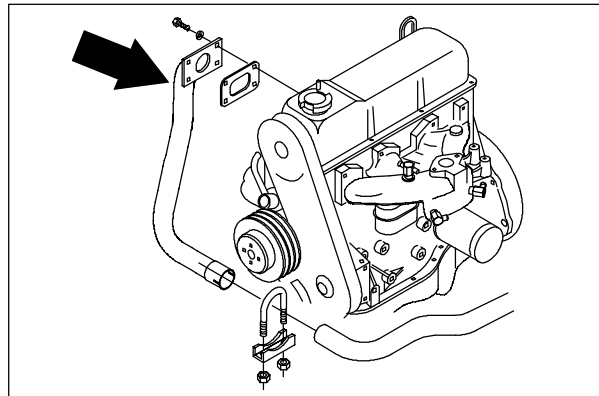
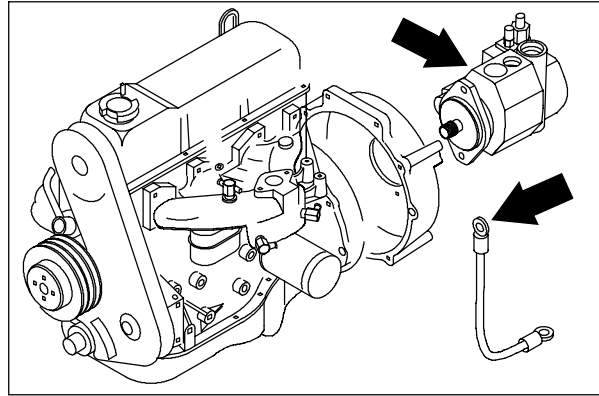

CONTENTS

| | Page |
|---|------|
| INTRODUCTION | 8-3 |
| LUBRICATION | 8-4 |
| ENGINE OIL | 8-4 |
| COOLING SYSTEM | 8-4 |
| RADIATOR | 8-4 |
| ENGINE FAN BELT | 8-5 |
| AIR INTAKE SYSTEM | 8-6 |
| AIR FILTER INDICATOR | 8-6 |
| AIR FILTER | 8-7 |
| TO REPLACE AIR FILTER ELEMENT | 8-7 |
| FUEL SYSTEM - DIESEL | 8-9 |
| DIESEL FUEL SYSTEM | 8-9 |
| FUEL FILTER | 8-9 |
| TO REPLACE THE FUEL FILTER CARTRIDGE | 8-9 |
| FUEL LINES | 8-10 |
| PRIMING THE FUEL SYSTEM ... | 8-10 |
| TO REPLACE ALTERNATOR | 8-12 |
| TO REPLACE STARTER | 8-14 |
| TO REMOVE ENGINE | 8-15 |
| TO INSTALL ENGINE | 8-17 |

DIESEL ENGINE SERVICE MANUAL

Kubota V2203-B
TENNANT Part Number 73032.

INTRODUCTION

This section includes repair information on the engine and related systems, such as fuel, electrical, and drive belts.

LUBRICATION

ENGINE OIL

Check the engine oil level daily. Change the engine oil and oil filter every 50 hours of machine operation. Use 10W30 SAE-CC/CD/CE rated engine oil.

Fill the engine with oil to the level indicated on the oil dipstick. Low oil level is indicated by the mark closest to the end of the dipstick. Full level is indicated by the mark closest to the top of the dipstick. The engine oil capacity is 6.15 L (6.5 qt) without the oil filter.

The engine oil filter is mounted on the right side of the machine frame above the scrub brushes.

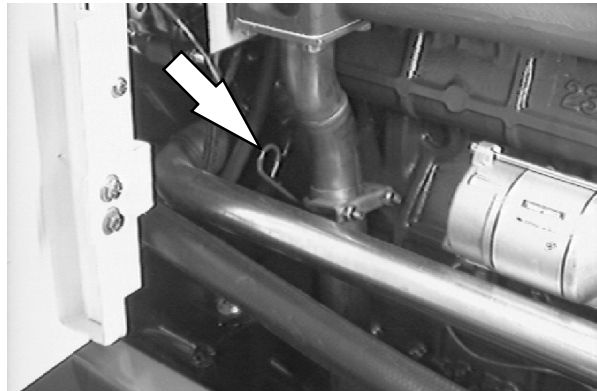

COOLING SYSTEM

RADIATOR

Check the radiator coolant level every 100 hours of operation. Use clean water mixed with a permanent-type, ethylene glycol antifreeze to a -34°C (-30°F) rating.

FOR SAFETY: When Servicing Machine, Avoid Contact With Hot Engine Coolant.

ATTENTION! Never pour cold water or cold antifreeze into the radiator of an overheated engine. Allow the engine to cool down to avoid cracking the cylinder head or block. Keep the engine running while adding water.

Check the radiator hoses and clamps every 200 hours of operation. Tighten the clamps if they are loose. Replace the hoses and clamps if the hoses are cracked, harden, or swollen.

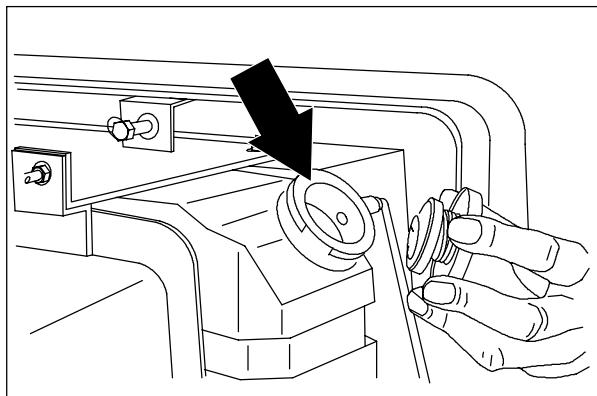

Check the radiator core exterior and hydraulic cooler fins for debris every 100 hours of operation. Blow or rinse all dust, which may have collected on the radiator, in through the grille and radiator fins, opposite the direction of normal air flow. The grille and hydraulic cooler open for easier cleaning. Be careful not to bend the cooling fins when cleaning. Clean thoroughly to prevent the fins becoming encrusted with dust. Clean the radiator and cooler only after the radiator has cooled to avoid cracking.

FOR SAFETY: When Servicing Machine, Wear Eye And Ear Protection When Using Pressurized Air Or Water.

Flush the radiator and the cooling system every 400 hours of operation, using a dependable cleaning compound.

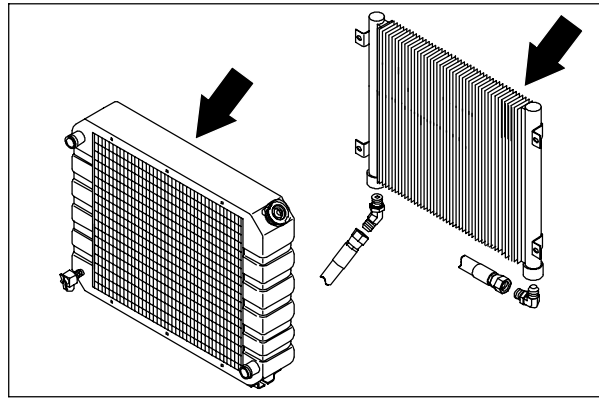

ENGINE FAN BELT

The engine fan belt is driven by the engine crankshaft pulley and drives the engine water pump and alternator pulleys. Proper belt tension is obtained when the belt deflects 7 to 9 mm (0.28 to 0.35 in) from a force of 10 kg (22 lb) applied at the mid-point of the longest span.

Check and adjust the belt tension every 100 hours of operation.



WARNING: Moving belt and fan. Keep away.

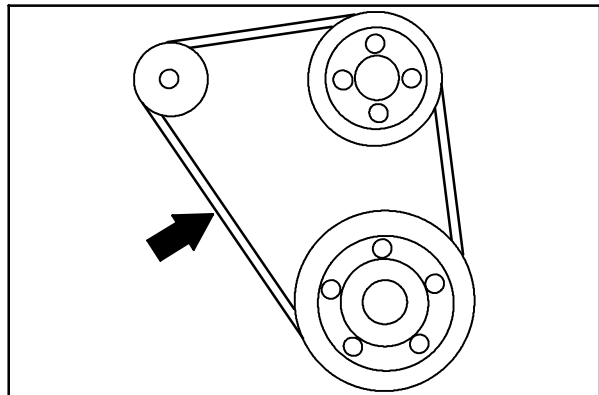

08935

AIR INTAKE SYSTEM

AIR FILTER INDICATOR

The air filter indicator shows when to clean or replace the air filter element. Check the indicator daily. The indicator's red line will move as the air filter element fills with dirt. Do not clean or replace the air filter element until the red line reaches 5 kPa (20 in H₂O) and the "SERVICE WHEN RED" window is filled with red. The indicator's red line may return to a lower reading on the scale when the engine shuts off. The red line will return to a correct reading after the engine runs for a while.



Reset the air filter indicator by pushing the reset button on the end of the indicator after cleaning or replacing the air filter element.

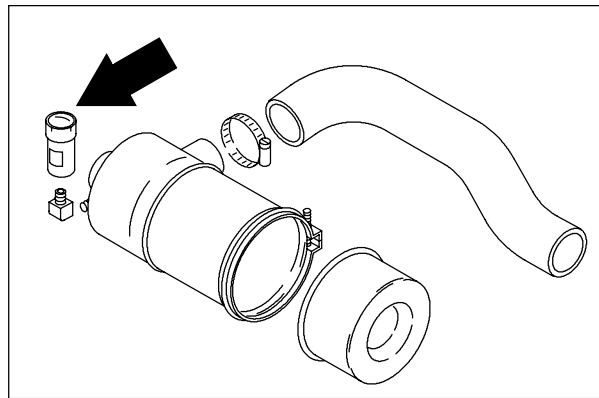

AIR FILTER

The engine air filter housing has a dust cap and a dry cartridge-type air filter element. Empty the dust cap daily. The air filter must be replaced whenever the filter element is damaged or when the air filter indicator shows a restriction. The air filters cannot be cleaned.

Machines with the heavy duty air filter option have a safety element. It is inside the standard element. Replace, do not clean this element after the regular element has been damaged or cleaned three times.

Replace the air filter element only when the air filter indicator shows restriction in the air intake system. Do not remove the air filter element from the housing unless it is restricting air flow.

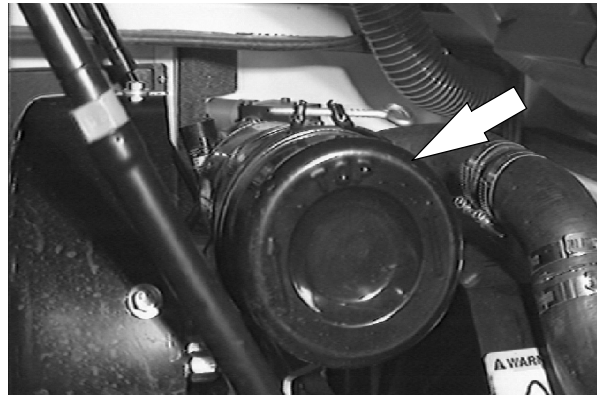

TO REPLACE AIR FILTER ELEMENT

1. Stop the engine and set the machine parking brake.

FOR SAFETY: Before Leaving Or Servicing Machine; Stop On Level Surface, Set Parking Brake, Turn Off Machine And Remove Key.

2. Open the left side and top engine access doors.
3. Unscrew the clamp ring on the filter assembly.
4. Remove the dust cap.
5. Empty the dust cap.
6. Remove the filter wing nut.
7. Gently pull the filter element out of the filter housing.
8. Clean the interior of the air cleaner housing with a damp cloth. Clean the element housing sealing surfaces.
9. Using an air hose, direct dry, clean air maximum 205 kPa (30 psi) up and down pleats on the inside of the filter. Do not rap, tap, or pound dust out of the element.

FOR SAFETY: When Servicing Machine, Wear Eye And Ear Protection When Using Pressurized Air Or Water.

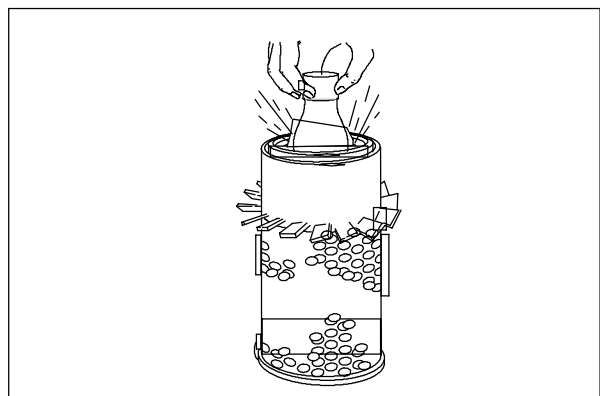
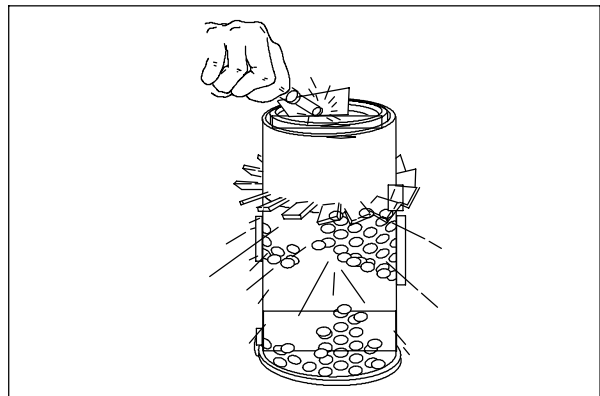

10. After cleaning the air filter element, inspect it for damage by placing a bright light inside. The slightest rupture requires replacement of the filter. Clean and inspect the seals on the ends of the element. They should be unbroken and flexible. *Remember to replace the element after cleaning it three times.*
11. Install the new or cleaned filter element so the fins on the element are at the intake end of the air cleaner. Be careful not to damage the fins. Make sure the element is seating evenly. Tighten the element wing nut.
12. Install the dust cap on the air filter housing with the arrows pointing up. Tighten the clamp ring to hold it in place. Check all intake hose connections for leaks or abrasion.
13. Reset the air filter restriction indicator.
14. Close the access doors.

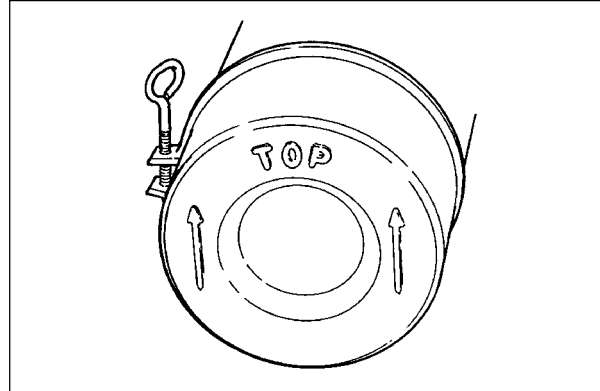

FUEL SYSTEM - DIESEL

DIESEL FUEL SYSTEM

The diesel fuel system is made up of five basic components which are: fuel tank, fuel filter, fuel water trap filter, fuel pump, injection pump, and injectors.

Fuel flows from the fuel tank through the fuel water trap-filter. The water trap-filter separates water and impurities from the fuel. From the fuel water trap-filter, fuel is drawn through the electric fuel pump and pumped to the injection pump. The injection pump pressurizes and sends fuel to the injectors. The injectors atomize and inject proper amounts of fuel into the combustion chamber at the proper times. Excess fuel is returned to the fuel tank through an overflow pipe.

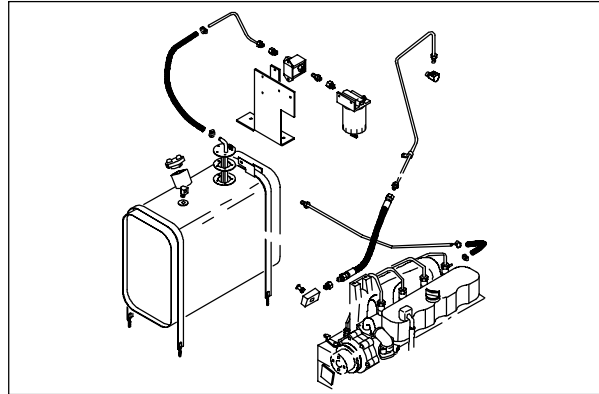

FUEL FILTER

The fuel filter cartridge filters impurities from the fuel. The filter is located by the fuel tank.

Replace the fuel filter element every 400 hours of operation.

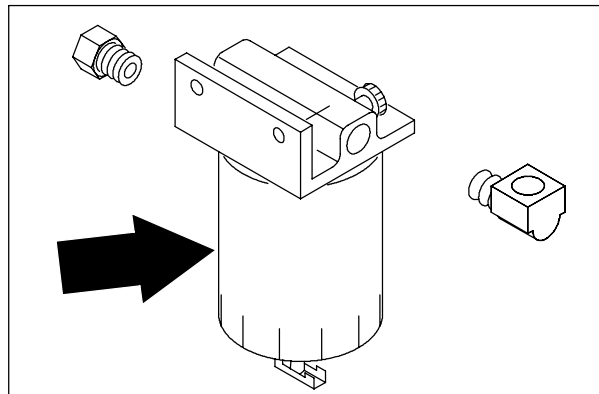

TO REPLACE THE FUEL FILTER CARTRIDGE

1. Stop the engine and set the machine parking brake.

FOR SAFETY: Before Leaving Or Servicing Machine; Stop On Level Surface, Set Parking Brake, And Turn Off Machine.

2. Loosen the unit vent plug and open the water trap drain to drain diesel fuel.
3. Remove the filter cartridge from the filter head.
4. Lubricate the o-ring of the new filter cartridge and spin it onto the filter head.
5. Bleed the fuel lines of air as described in TO PRIME FUEL SYSTEM instructions.

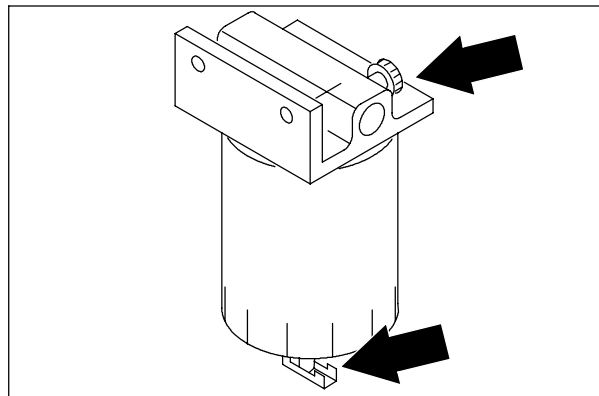

FUEL LINES

Check the fuel lines every 50 hours of operation. If the clamp band is loose, apply oil to the screw of the band, and securely tighten the band.

Made of rubber, the fuel lines become worn out whether the engine has been used much or not. Replace the fuel lines and clamp bands every two years.

If the fuel lines and clamp bands are found worn or damaged before two years' time, replace or repair them at once. Bleed the fuel system after replacement of any of the fuel lines, see PRIMING THE FUEL SYSTEM instructions. When the fuel lines are not installed, plug both ends with clean cloth or paper to prevent dirt from entering the lines. Dirt in the lines can cause fuel injection pump malfunction.

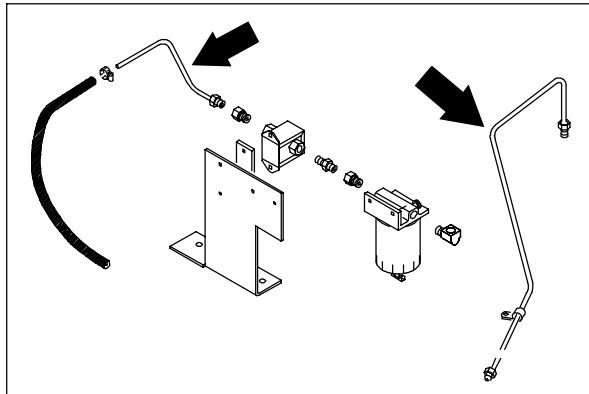

PRIMING THE FUEL SYSTEM

Priming the fuel system removes pockets of air in the fuel lines and fuel components. Air in the fuel system will prevent smooth engine operation.

Prime the fuel system after running out of fuel, changing fuel filter elements or repairing a fuel system component.

1. Stop the engine and set the machine parking brake.

FOR SAFETY: Before Leaving Or Servicing Machine; Stop On Level Surface, Set Parking Brake, And Turn Off Machine.

2. Make sure the fuel tank is full.
3. Raise the seat up.
4. Unplug the RH tail light from the main harness.

5. Loosen the two M8 hex screws holding the RH rear panel to the center tower.
6. Go to the back of the machine and remove the two M8 hex screws holding the rear panel to the RH corner tower.
7. Remove the rear panel for access to the fuel filter.
8. Open the air vent on top of the fuel filter.

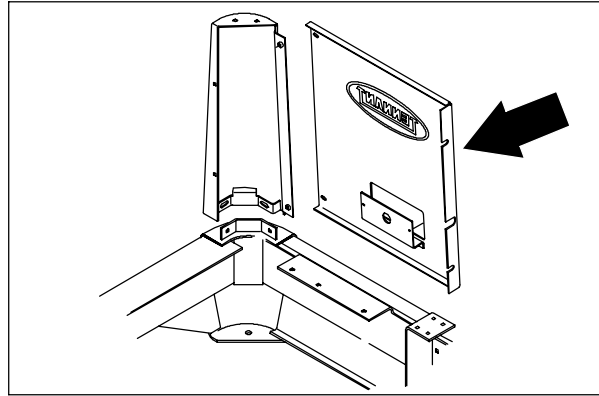

9. Start the engine, operate it for one minute, then stop it; or operate the starter motor in ten-second intervals until a steady stream of fuel flows from the vent.
10. Close the air vent and shut off the engine.
11. Position the RH rear access panel back on the machine, Reinstall the two M8 hex screws and tighten to 18 - 24 Nm (15 - 20 ft lb).
12. Go under the seat and tighten the two M8 hex screws to 18 - 24 Nm (15 - 20 ft lb).
13. Reconnect the tail light to the main harness.
14. Lower the seat.

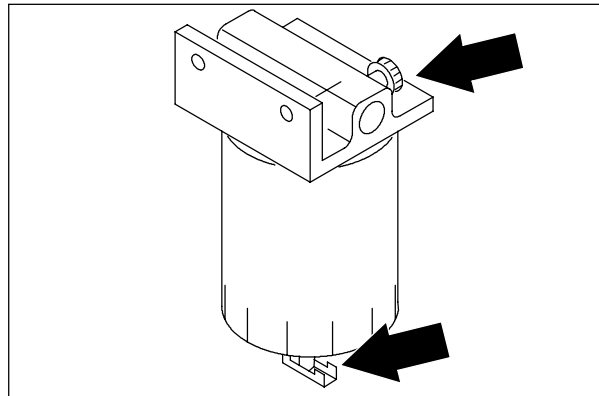

TO REPLACE ALTERNATOR

FOR SAFETY: Before Leaving Or Servicing Machine; Stop On Level Surface, Set Parking Brake, Turn Off Machine And Remove Key.

1. Disconnect the battery cables from the battery.
2. Open the engine cover and side door.
3. Disconnect the wires on the back of the alternator.
4. Remove the hex screw holding the top of the alternator to the upper mount bracket. Push the alternator toward the engine and remove the v-belt.
5. Remove the hex screw and nyloc nut holding the bottom of the alternator to the lower mount bracket.
6. The alternator can now be removed. Bring the alternator up and out of the machine.
7. If the new or rebuilt alternator needs a drive pulley; remove the pulley from the old alternator by holding pulley from turning and using an impact wrench to remove hex nut.
8. Install pulley, washer, and hex nut on the new alternator. Hand tighten the nut with an impact wrench.

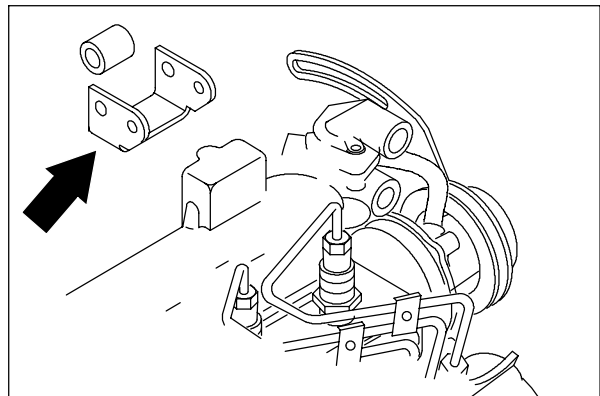
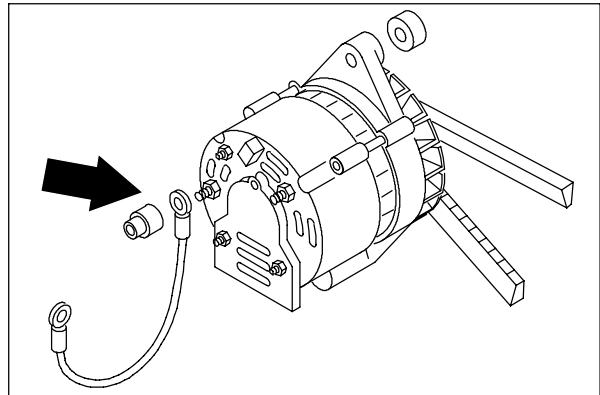
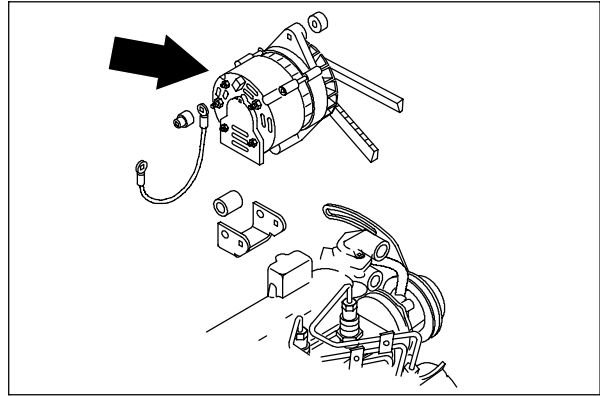

9. Install the new alternator back in the machine. Align the bottom hole in the alternator with hole in the lower mount bracket. Reinstall the hex bolt, washer, and sleeve. Leave loose for now.
10. Place the v-belt back on the alternator pulley.
11. Reinstall the hex screw in the top hole of the alternator through the upper mounting bracket. Pull alternator toward the outside of machine to tighten belt. Tighten the hex screw to 18 - 24 Nm (13 - 18 ft lb).
12. Tighten the bottom hex screw to 31 - 40 Nm (27 - 35 ft lb).
13. Reconnect the wires to the back of alternator. See the schematic in the ELECTRICAL section.
14. Reconnect the battery, start the engine, and check for proper operation of the new alternator.

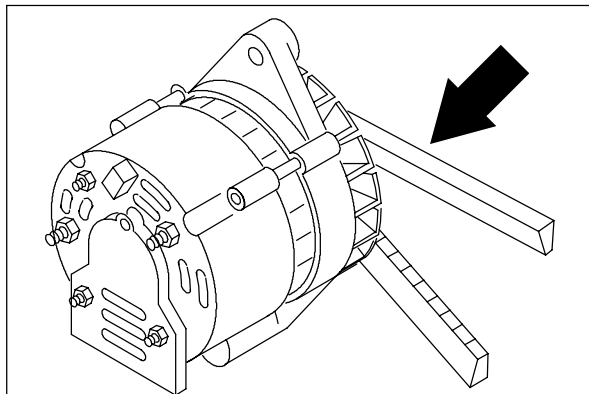

TO REPLACE STARTER

FOR SAFETY: Before Leaving Or Servicing Machine; Stop On Level Surface, Set Parking Brake, Turn Off Machine And Remove Key.

1. Disconnect the battery cables from the battery.
2. Open the engine cover and side door.
3. Remove the vacuum hose from the exhaust side of scrubbing vacuum fan.
4. Remove the M8 hex nut holding positive battery cable to the starter. Remove the cable and unplug the starter wires.
5. Remove one hex nut and one hex screw holding the starter to the bellhousing. Remove the starter from machine.
6. Position the new starter back in the machine. Align the top hole in the starter with the stud on bellhousing.
7. Reinstall one hex nut and one hex screw. Firmly hand tighten.
8. Reconnect the battery cable and starter wires to starter. See the schematic in the ELECTRICAL section.
9. Reinstall the vacuum hose to the exhaust side of scrubbing vacuum fan.
10. Reconnect the battery cables to the battery. Start the engine to check the new starter for proper operation.

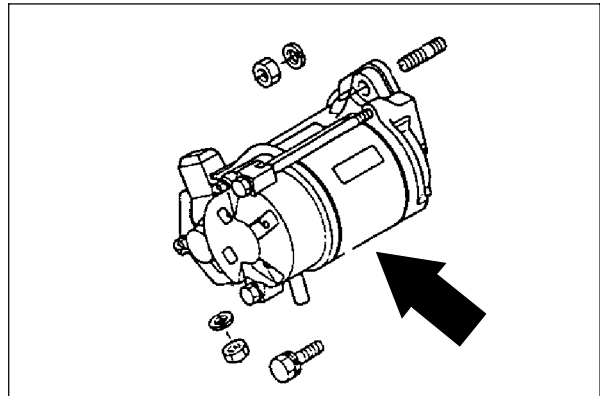
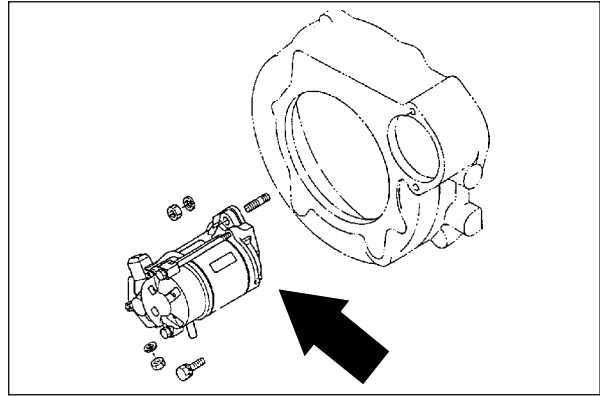

TO REMOVE ENGINE

FOR SAFETY: Before Leaving Or Servicing Machine; Stop On Level Surface, Set Parking Brake., Turn Off Machine And Remove Key.

1. Remove the engine cover and side door.
2. Remove the battery cables from the battery.
3. Drain the radiator.
4. Drain the engine oil.
5. Remove the air cleaner assembly from the mounting bracket.
6. Disconnect and plug the hydraulic hoses on the scrubber vacuum fan motor.

NOTE: Observe hydraulic cleanliness requirements when opening hydraulic lines.

7. Remove the scrubber vacuum fan assembly and vacuum hose.
8. Remove the vacuum fan/air cleaner mount bracket from the engine.
9. Remove the radiator hoses from the engine.
10. Disconnect the exhaust pipe at the engine manifold.
11. Disconnect the main electrical wire harness from all engine components and place it out of the way.
12. Disconnect the engine ground strap from the machine frame.
13. Disconnect both the fuel line and the return line leading from the fuel tank to the engine.
14. Disconnect the throttle cable from the engine.

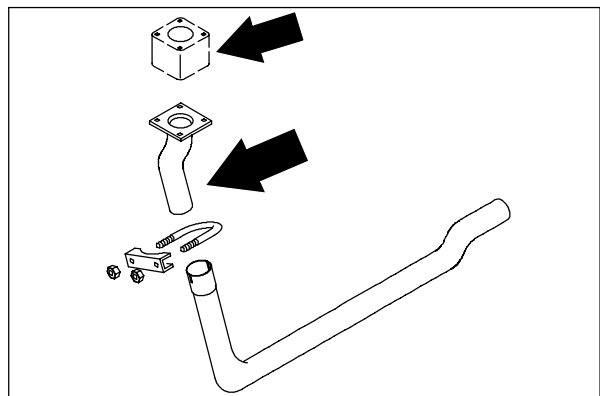
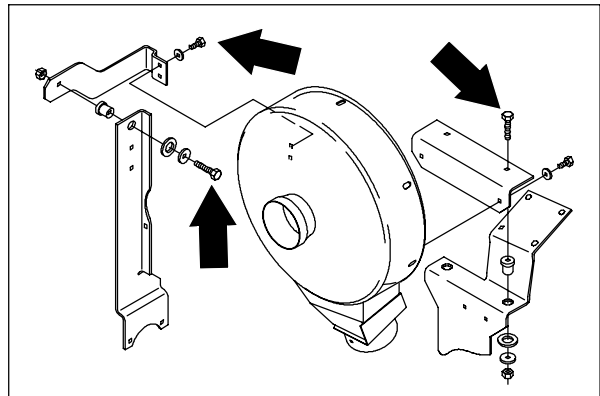
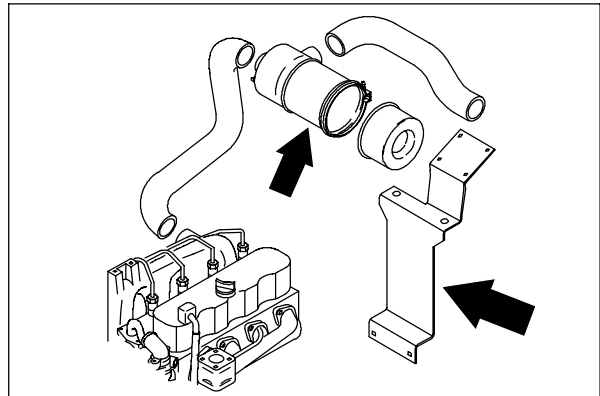
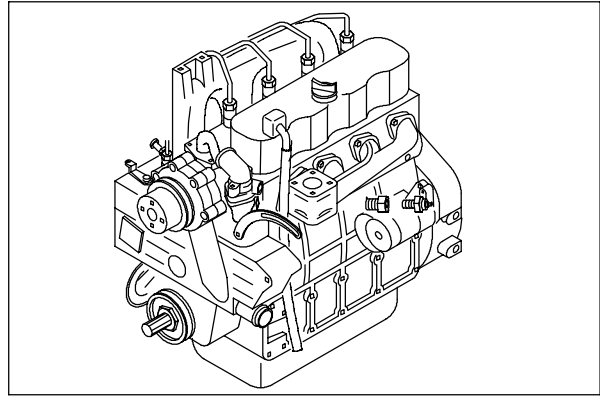

ENGINE-DIESEL

15. Disconnect and plug the two engine oil lines, coming from the remote oil filter, at the engine oil filter adaptor.

NOTE: Observe engine oil cleanliness requirements when opening remote filter lines.

16. Remove the LH side panel.
17. Remove the side door mounting bracket from the machine.
18. Remove the left rear grill panel for access to the hydraulic pump assemblies.
19. Remove the two M12 hex screws holding the load sensing / propel pump assembly to the flywheel housing.
20. Pull the load sensing / propel pump assembly back and out of flywheel housing.
21. Using an overhead hoist; hook a chain through the two pick-up points on engine. Put a slight amount of tension on the chain.
22. Remove the four M12 hex screws holding the motor mounts to the rubber isolators.
23. The engine can now be carefully lifted out.

NOTE: Be sure to disconnect engine oil drain hose from oil pan before lifting engine completely out of the machine.

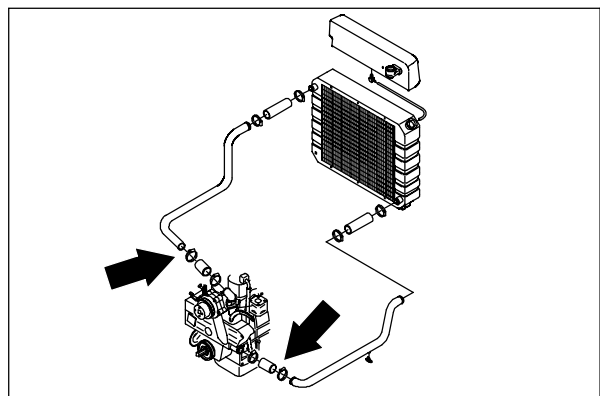
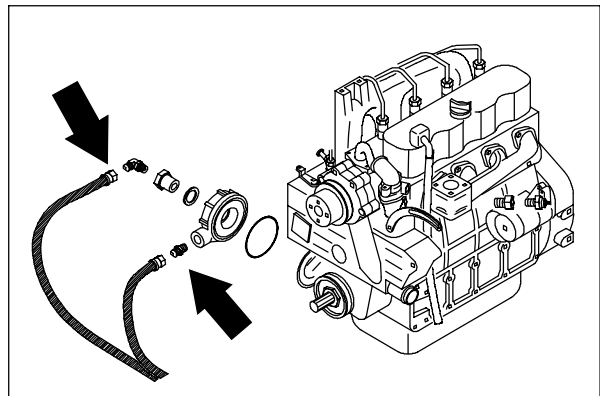
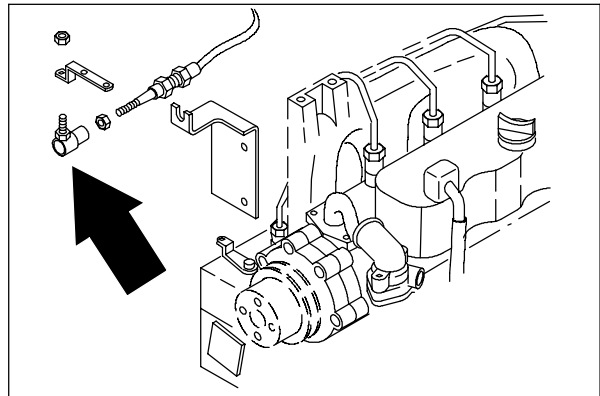
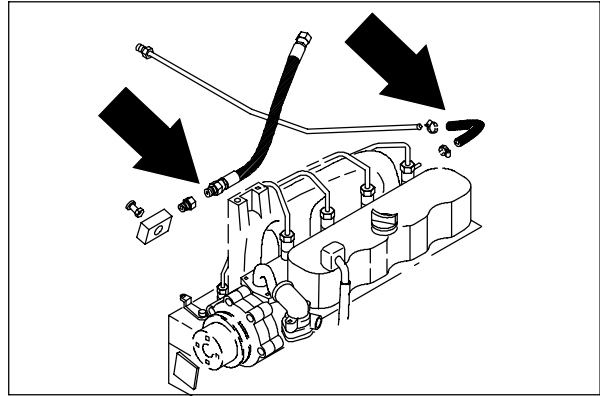

TO INSTALL ENGINE

FOR SAFETY: Before Leaving Or Servicing Machine; Stop On Level Surface, Set Parking Brake., Turn Off Machine And Remove Key.

1. Hook a chain through the two pick-up points on the engine. Use an over head hoist to lift the engine in the engine compartment.
2. Carefully lower the engine assembly down on the motor mounts.

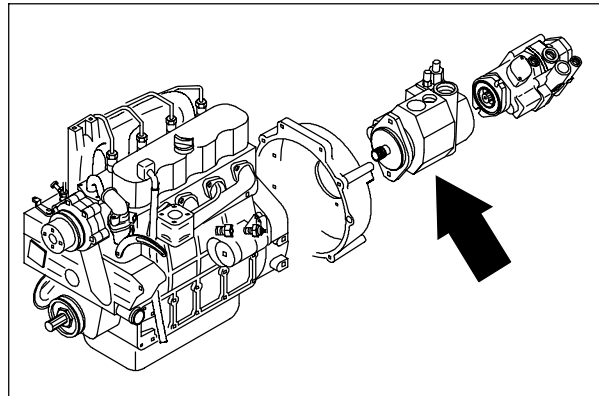

NOTE: Make sure the hoses, wire harness, exhaust pipe, and load sensing pump are pulled back out of the way when lowering the engine assembly in place.

3. Reinstall the M12 hex screws in the four engine motor mounts. Tighten to 64 – 83 Nm (50 – 60 ft lb).
4. Reconnect the ground cable from the bellhousing to the machine frame.
5. Reinstall load sensing pump back in the bellhousing. Reinstall the M12 hex screws. Tighten to 64 – 83 Nm (50 – 60 ft lb).

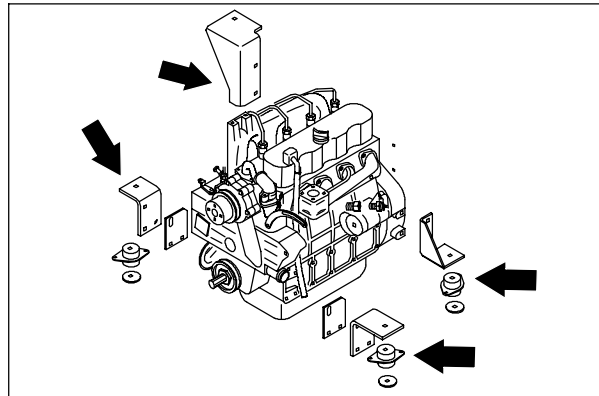

NOTE: Make sure the splines on pump line up with splines in coupler when installing pump.

6. Reinstall exhaust pipe back on the engine manifold. Reinstall the four M10 hex screws. Tighten to 52 – 67Nm (39 – 51 ft lb).

NOTE: Make sure the steel gasket is in place when installing exhaust pipe.

7. Reconnect the fuel lines.
8. Reconnect the two engine oil lines to the remote oil filter adaptor on the engine.

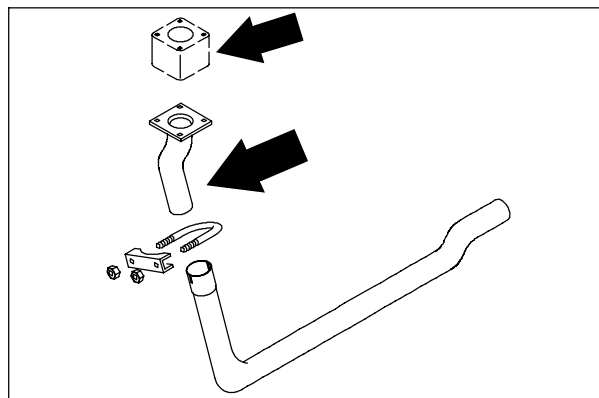

NOTE: Observe engine oil cleanliness requirements when opening remote filter lines.

9. Reconnect the throttle cable to the engine.

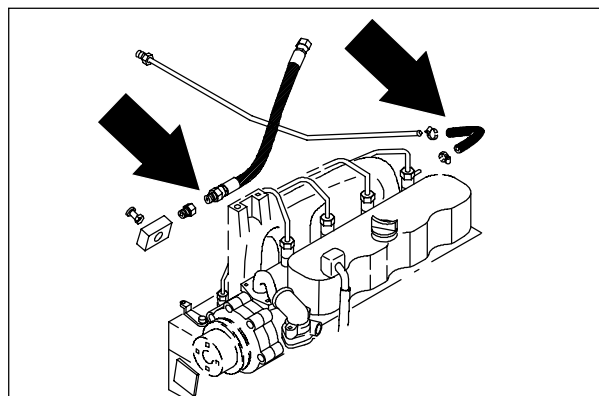

ENGINE-DIESEL

10. Fill the engine with proper grade of motor oil.
11. Reconnect wire harness to the engine components: alternator, starter, oil switch, temperature sender.
12. Reinstall the radiator hoses to engine and fill the radiator with coolant.
13. Reinstall the vacuum fan/air cleaner mount bracket to bellhousing. Reinstall the two M10 hex screws and tighten to 37 - 48 Nm (26 - 34 ft lb).
14. Reinstall the vacuum fan assembly to the mount bracket. Reinstall the three M10 hex screws, six washers, and three nyloc nuts. Tighten to 34 - 44 Nm (24 - 28 ft lb).
15. Reconnect the hydraulic hoses to the scrubbing vacuum fan motor. See the schematic in the HYDRAULICS section of this manual.
16. Reinstall the air cleaner assembly.
17. Reinstall the LH side panel using the three M6 hex screws and washers and two M8 hex screws and washers. Tighten the M6 hex screws to 11 - 14 Nm (7 - 10 ft lb). Tighten the M8 hex screws to 18 - 24 Nm (15 - 20 ft lb).
18. Reinstall the left rear grill panel to the machine. Reinstall the two M8 hex screws and washers. Tighten to 18 - 24 Nm (15 - 20 ft lb).
19. Reinstall the engine cover and side door.
20. Reconnect the battery cables to the battery.
21. Jack up the rear of the machine.

FOR SAFETY: Block machine tires before jacking machine up. Jack machine up at designated locations only. Block machine up with jack stands

22. Start the engine and check for any leaks.

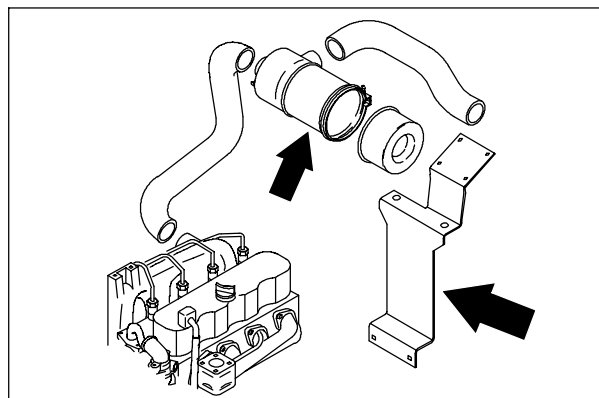
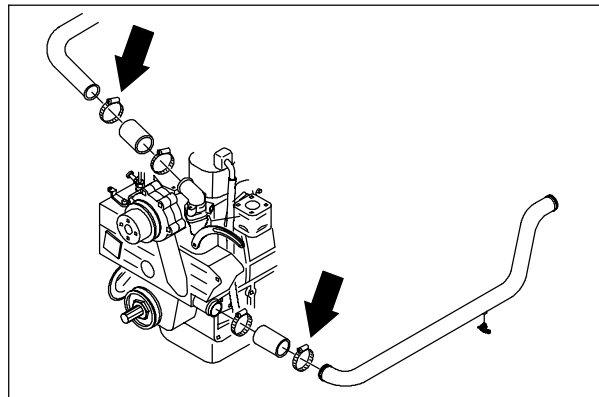
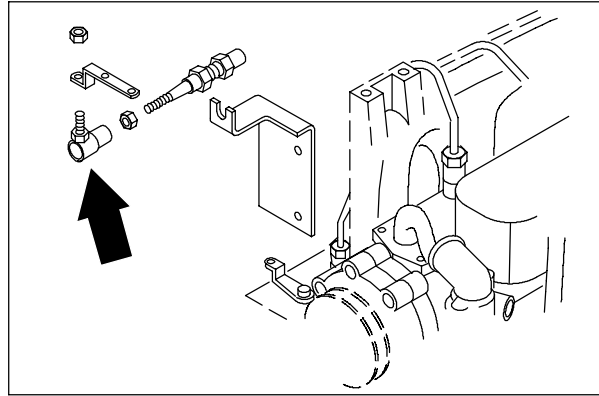



We Need Your Help...

As part of Tennant's Zero Defects Program, we want to know about errors you have found or suggestions you may have regarding our machine manuals. If you find an error or have a suggestion, please complete this postage-paid form and mail it to us. Thank you for helping us make zero defects a way of life at Tennant.

Manual No. _____ Rev. No. _____ Publish Date _____ Page _____
Machine _____ Report Error Suggestion

Name _____ Date _____
Customer Number _____
Company _____
Address _____
City/State/Zip Code _____



TENNANT COMPANY
 Technical Publications #15
 701 North Lilac Drive
 P.O. Box 1452
 Minneapolis, MN 55440-9947

POSTAGE WILL BE PAID BY ADDRESSEE

BUSINESS REPLY MAIL
 FIRST CLASS MAIL PERMIT NO. 94 MINNEAPOLIS, MN

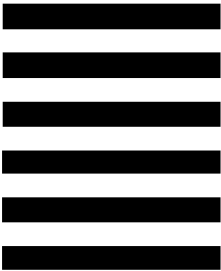

NO POSTAGE
 NECESSARY
 IF MAILED
 IN THE
 UNITED STATES

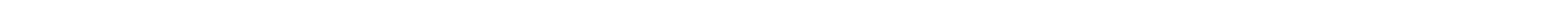
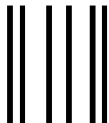

Fold along dotted lines

Tape here

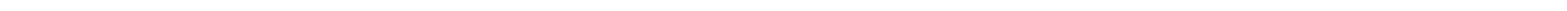



We Need Your Help...

As part of Tennant’s Zero Defects Program, we want to know about errors you have found or suggestions you may have regarding our machine manuals. If you find an error or have a suggestion, please complete this postage-paid form and mail it to us. Thank you for helping us make zero defects a way of life at Tennant.

Manual No. _____ Rev. No. _____ Publish Date _____ Page _____

Machine _____ Report Error Suggestion

Name _____ Date _____

Customer Number _____

Company _____

Address _____

City/State/Zip Code _____



TENNANT COMPANY
 Technical Publications #15
 701 North Lilac Drive
 P.O. Box 1452
 Minneapolis, MN 55440-9947

POSTAGE WILL BE PAID BY ADDRESSEE

BUSINESS REPLY MAIL
 FIRST CLASS MAIL PERMIT NO. 94 MINNEAPOLIS, MN

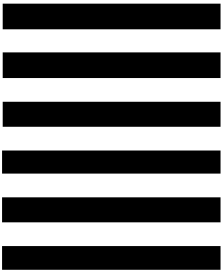

NO POSTAGE
 NECESSARY
 IF MAILED
 IN THE
 UNITED STATES

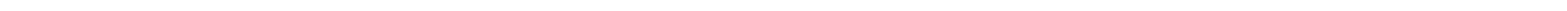
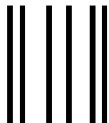

Fold along dotted lines

Tape here

