

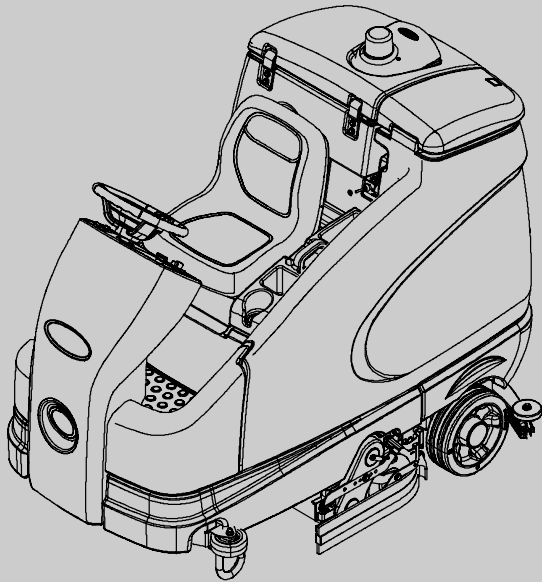

T16

Rider Scrubber Service Information Manual



The Safe Scrubbing Alternative®



Hygenic® Fully Cleanable Tanks
ES® Extended Scrub System

North America / International

www.tennantco.com

9008149
Rev. 00 (1-2011)





This manual provides necessary maintenance, troubleshooting and repair instructions.

Read this manual completely and understand the machine before operating or servicing it.

This machine will provide excellent service. However, the best results will be obtained at minimum costs if:

- The machine is operated with reasonable care.
- The machine is maintained regularly - per the machine maintenance instructions provided.
- The machine is maintained with manufacturer supplied or equivalent parts.

| | |
|---|---|
|  | PROTECT THE ENVIRONMENT |
|  | Please dispose of packaging materials, old machine components such as batteries, hazardous fluids including antifreeze and oil, in an environmentally safe way according to local waste disposal regulations. |
| | Always remember to recycle. |

| | |
|---|-------|
| MACHINE DATA | |
| Please fill out at time of installation for future reference. | |
| Model No. - | _____ |
| Serial No. - | _____ |
| Machine Options - | _____ |
| Sales Rep. - | _____ |
| Sales Rep. phone no. - | _____ |
| Customer Number - | _____ |
| Installation Date - | _____ |

Tennant Company

PO Box 1452

Minneapolis, MN 55440

Phone: (800) 553-8033 or (763) 513-2850

www.tennantco.com

Touch-N-Go, 1-STEP, Grip-N-Go, Dura-Track, Positive Drain Control, SmartRelease, Duramer, FaST-PAK, are US registered and unregistered trademarks of Tennant Company.

Specifications and parts are subject to change without notice.

Original Instructions, copyright © 2010 TENNANT Company, Printed in U.S.A.

| Contents | Page |
|---|-------------|
| Safety Precautions | 1-1 |
| General Information | 2-1 |
| Component Locator | 2-2 |
| Electrical Schematic, Master | 2-4 |
| Electrical Schematic Symbols | 2-10 |
| Operational Matrix | 2-11 |
| Specifications | 2-14 |
| Fastener Torque | 2-14 |
| General Machine Dimensions/ Capacities | 2-15 |
| General Machine Performance | 2-15 |
| Power Type | 2-16 |
| Tires | 2-16 |
| FaST System (Option) | 2-17 |
| ec-H2O System (Option) | 2-17 |
| Electrical Components | 2-17 |
| Machine Dimensions | 2-19 |
| Maintenance | 3-1 |
| Maintenance Chart | 3-2 |
| Lubrication | 3-4 |
| Steering Chain | 3-4 |
| Rear Squeegee Casters | 3-4 |
| Steering Gear Chain | 3-4 |
| Batteries | 3-5 |
| Charging the Batteries (Off-Board Charger) | 3-6 |
| Charging the Batteries (Onboard Charger) | 3-7 |
| Circuit Breakers | 3-8 |
| Electric Motors | 3-8 |
| Scrub Brushes | 3-9 |
| Disk Brushes and Pads | 3-9 |
| Replacing Disk Brushes (or Pad Drivers) | 3-9 |
| Replacing Disk Scrub Pads | 3-10 |
| Cylindrical Brushes | 3-11 |
| Replacing Cylindrical Brushes | 3-11 |
| Checking Cylindrical Scrub Brush Pattern | 3-12 |
| Adjusting Cylindrical Brush Taper | 3-15 |
| Adjusting Cylindrical Brush Pattern Width | 3-16 |
| Side Brush (Option) | 3-17 |
| Replacing the Side Brush | 3-17 |
| Pre-Sweep Brushes | 3-18 |
| Replacing the Pre-Sweep Disk Brushes | 3-18 |
| Replacing the Pre-Sweep Cylindrical Brush | 3-19 |
| Checking and Adjusting Pre-Sweep Cylindrical Brush Pattern | 3-20 |

| Contents | Page |
|---|-------------|
| FaST | 3-24 |
| Replacing the FaST-Pak Carton | 3-24 |
| Cleaning the FaST Supply Hose Connector | 3-24 |
| Replacing the FaST Injector Filters | 3-24 |
| ec-H2O Module Flush Procedure | 3-25 |
| Squeegee Blades | 3-27 |
| Replacing (or Rotating) the Rear Squeegee Blades | 3-27 |
| Leveling the Rear Squeegee | 3-30 |
| Adjusting the Rear Squeegee Blade Deflection | 3-31 |
| Replacing (or Rotating) the Side Squeegee Blades | 3-32 |
| Replacing (or Rotating) the Side Brush Squeegee Blade(s) (Option) | 3-33 |
| Skirts and Seals | 3-35 |
| Pre-Sweep Side Skirts (Option) | 3-35 |
| Pre-Sweep Recirculation Skirt (Option) | 3-35 |
| Pre-Sweep Rear Skirt (Option) | 3-35 |
| Belts and Chains | 3-36 |
| Steering Chain | 3-36 |
| Cylindrical Brush Drive Belts | 3-36 |
| Pre-Sweep Brush Drive Belt | 3-36 |
| Tires | 3-36 |
| Pushing, Towing, and Transporting the Machine | 3-37 |
| Pushing or Towing the Machine | 3-37 |
| Transporting the Machine | 3-37 |
| Machine Jacking | 3-39 |
| Storage Information | 3-39 |
| Freeze Protection (Machines without Optional ec-H2O System) | 3-40 |
| Preparing the Machine for Operation (Machines without Optional ec-H2O System) | 3-41 |
| Freeze Protection (Machines with Optional ec-H2O System) | 3-42 |
| Priming the ec-H2O System | 3-44 |
| Troubleshooting | 4-1 |
| Onboard Diagnostics | 4-2 |
| Self-Test Mode | 4-2 |
| Configuration Mode | 4-4 |
| LCD Warnings | 4-6 |
| LCD Faults | 4-7 |
| Propel Diagnostic Mode | 4-9 |
| Curtis 1234 Controller Diagnostics | 4-11 |
| Diagnostic LED Operation | 4-11 |
| Diagnostic Codes | 4-12 |
| Input Display Mode | 4-20 |
| Manual Mode | 4-22 |

CONTENTS

| Contents | Page |
|---|-------------|
| Battery Charger, Standard | 4-24 |
| Operation | 4-24 |
| Configuration | 4-24 |
| Faults | 4-24 |
| Battery Charger, Onboard Option | 4-25 |
| Operation | 4-25 |
| Configuration, Lead-Acid/Gel | 4-25 |
| Faults | 4-25 |
| Subsystem Troubleshooting | 4-26 |
| Back-Up Alarm/Light | 4-26 |
| Electrical Schematic | 4-26 |
| Troubleshooting | 4-27 |
| Battery Charging | 4-28 |
| Electrical Schematic, Onboard | 4-28 |
| Troubleshooting | 4-29 |
| Electrical Schematic, Off Board | 4-30 |
| Troubleshooting | 4-31 |
| Parking Brake, Electromagnetic | 4-32 |
| Electrical Schematic | 4-32 |
| Troubleshooting | 4-33 |
| Detergent Metering | 4-34 |
| Electrical Schematic | 4-34 |
| Troubleshooting | 4-35 |
| Extended Scrub | 4-36 |
| Electrical Schematic | 4-36 |
| Troubleshooting | 4-37 |
| Lighting | 4-38 |
| Electrical Schematic | 4-38 |
| Troubleshooting | 4-39 |
| Main Scrub Brushes | 4-40 |
| Electrical Schematic | 4-40 |
| Troubleshooting | 4-41 |
| Power-Up | 4-42 |
| Electrical Schematic | 4-42 |
| Troubleshooting | 4-43 |
| Pre-Sweep Brushes | 4-44 |
| Electrical Schematic | 4-44 |
| Troubleshooting | 4-45 |
| Pre-Sweep Lift | 4-46 |
| Electrical Schematic, Down | 4-46 |
| Troubleshooting | 4-47 |
| Electrical Schematic, Up | 4-48 |
| Troubleshooting | 4-49 |
| Propel | 4-50 |
| Electrical Schematic | 4-50 |
| Troubleshooting | 4-51 |
| Rear Squeegee Lift | 4-52 |
| Electrical Schematic | 4-52 |
| Troubleshooting | 4-53 |

| Contents | Page |
|--|-------------|
| Subsystem Troubleshooting, continued | |
| Scrub Head Lift | 4-54 |
| Electrical Schematic | 4-54 |
| Troubleshooting | 4-55 |
| Side Brush | 4-56 |
| Electrical Schematic | 4-56 |
| Troubleshooting | 4-57 |
| Side Brush Lift | 4-58 |
| Electrical Schematic, Down | 4-58 |
| Troubleshooting | 4-59 |
| Electrical Schematic, Up | 4-60 |
| Troubleshooting | 4-61 |
| Solution Control, Conventional | 4-62 |
| Electrical Schematic | 4-62 |
| Troubleshooting | 4-63 |
| Solution Control, ecH2O | 4-64 |
| Electrical Schematic | 4-64 |
| Troubleshooting | 4-65 |
| Solution Control, FaST | 4-66 |
| Electrical Schematic | 4-66 |
| Troubleshooting | 4-67 |
| Spray Nozzle | 4-68 |
| Electrical Schematic | 4-68 |
| Troubleshooting | 4-69 |
| Vacuum Fan(s), Scrubbing | 4-70 |
| Electrical Schematic | 4-70 |
| Troubleshooting | 4-71 |
| Vacuum Fan, Pre-Sweep | 4-72 |
| Electrical Schematic | 4-72 |
| Troubleshooting | 4-73 |
| Service | 5-1 |
| Service Procedures | 5-2 |
| Rear Squeegee Lift Actuator | 5-2 |
| Removal | 5-2 |
| Installation | 5-3 |
| Side Brush Lift Actuator | 5-6 |
| Removal | 5-6 |
| Installation | 5-7 |
| Main Brush Lift Actuator | 5-8 |
| Removal | 5-8 |
| Installation | 5-8 |
| Main Scrub Head | 5-9 |
| Removal | 5-9 |
| Installation | 5-10 |
| Main Scrub Brush Motor (Cylindrical) | 5-11 |
| Removal | 5-11 |
| Installation | 5-12 |
| Carbon Brushes | 5-12 |

| Contents | Page |
|--|-------------|
| Service Procedures, continued | |
| Side Brush Motor (Non Pre-Sweep) | 5-13 |
| Removal | 5-13 |
| Installation | 5-14 |
| Carbon Brushes | 5-14 |
| Instrument Panel | 5-15 |
| Removal | 5-15 |
| Installation | 5-15 |
| Logic Board | 5-16 |
| Removal | 5-16 |
| Installation | 5-17 |
| Steering Cable Adjustment | 5-18 |
| Steering Wheel Timing | 5-19 |
| Wheel Drive Assembly | 5-20 |
| Removal | 5-20 |
| Installation | 5-20 |
| Tire Replacement | 5-20 |
| Vacuum Fan Assembly (Scrubbing) | 5-22 |
| Removal | 5-22 |
| Installation | 5-23 |
| Component Testing | 5-24 |
| Solution Tank Level Sensor | 5-24 |
| Recovery Tank Level Sensor | 5-26 |
| Parking Brake, Electromagnetic | 5-28 |
| Propel Motor (and Encoder) | 5-31 |
| Propel Motor Cables | 5-33 |
| Throttle/Brake Sensor | 5-35 |
| Pre-Sweep Lift Actuator | 5-37 |
| Side Brush Lift Actuator | 5-38 |
| Main Brush Lift Actuator | 5-39 |
| Rear Squeegee Lift Actuator | 5-40 |
| Vacuum Fan(s) (Scrubbing) | 5-41 |
| Vacuum Fan (Pre-Sweep) | 5-42 |
| Main Scrub Brush Motor(s) | 5-43 |
| Main Sweep Broom Motor | 5-44 |
| Side Brush Motor (Non Pre-Sweep) | 5-45 |
| Side Brush Motor (Pre-Sweep) | 5-46 |
| ec-H2O Pump | 5-47 |
| Adjusting ec-H2O Flow Rate | 5-47 |
| ec-H2O Pressure Switch | 5-48 |
| FaST Pump | 5-49 |
| ES (Extended Scrub) Pump | 5-50 |

SAFETY PRECAUTIONS

The following precautions are used throughout this manual as indicated in their description:



WARNING: To warn of hazards or unsafe practices that could result in severe personal injury or death.



CAUTION: To warn of unsafe practices that could result in minor or moderate personal injury.

FOR SAFETY: To identify actions that must be followed for safe operation of equipment.

This machine is designed solely for scrubbing dirt and dust in a well lit indoor environment. Tennant does not recommend using this machine in any other environment.

The following information signals potentially dangerous conditions to the operator or equipment. Read this manual carefully. Know when these conditions can exist. Locate all safety devices on the machine. Then, take necessary steps to train machine operators. Report machine damage or faulty operation immediately. Do not use the machine if it is not in proper operating condition.



WARNING: Batteries emit hydrogen gas. Explosion or fire can result. Keep sparks and open flame away. Keep covers open when charging.



WARNING: Flammable materials can cause an explosion or fire. Do not use flammable materials in tank(s).



WARNING: Flammable materials or reactive metals can cause an explosion or fire. Do not pick up.

FOR SAFETY:

1. Do not operate machine:

- Unless trained and authorized.
- Unless operation manual is read and understood.
- With brake disabled.
- If it is not in proper operating condition.
- In flammable or explosive areas.
- In areas with possible falling objects unless equipped with overhead guard.

2. Before starting machine:

- Make sure all safety devices are in place and operate properly.
- Check brakes and steering for proper operation.
- Adjust seat and fasten seat belt (if so equipped).

3. When using machine:

- Do not pick up burning or smoking debris, such as cigarettes, matches or hot ashes
- Go slowly on inclines and slippery surfaces.
- Use care when backing machine.
- Do not carry passengers on machine.
- Follow mixing and handling instructions on chemical containers.
- Report machine damage or faulty operation immediately.

4. Before leaving or servicing machine:

- Stop on level surface.
- Turn off machine and remove key.

5. When servicing machine:

- Avoid moving parts. Do not wear loose clothing or jewelry when working on machine.
- Block machine tires before jacking machine up.
- Jack machine up at designated locations only. Block machine up with jack stands.
- Use hoist or jack that will support the weight of the machine.
- Wear eye and ear protection when using pressurized air or water.
- Disconnect battery connections before working on machine.
- Wear protective gloves and eye protection when handling vinegar.
- Avoid contact with battery acid.
- Use Tennant supplied or equivalent replacement parts.

6. When loading/unloading machine onto/off truck or trailer.

- Turn off machine.
- Use truck or trailer that will support the weight of the machine.
- Use winch. Do not push the machine onto/off the truck or trailer unless the load height is 380 mm (15 in) or less from the ground.
- Block machine tires.

SAFETY PRECAUTIONS

The safety labels appear on the machine in the locations indicated. Replace damaged labels.

BATTERY CHARGING LABEL - LOCATED ON SEAT PANEL.



FLAMMABLE MATERIALS LABEL - LOCATED ON UNDERSIDE OF RECOVERY TANK COVER AND ON CIRCUIT BREAKER PANEL.



FLAMMABLE SPILLS LABEL - LOCATED ON UNDERSIDE OF SOLUTION TANK COVER.

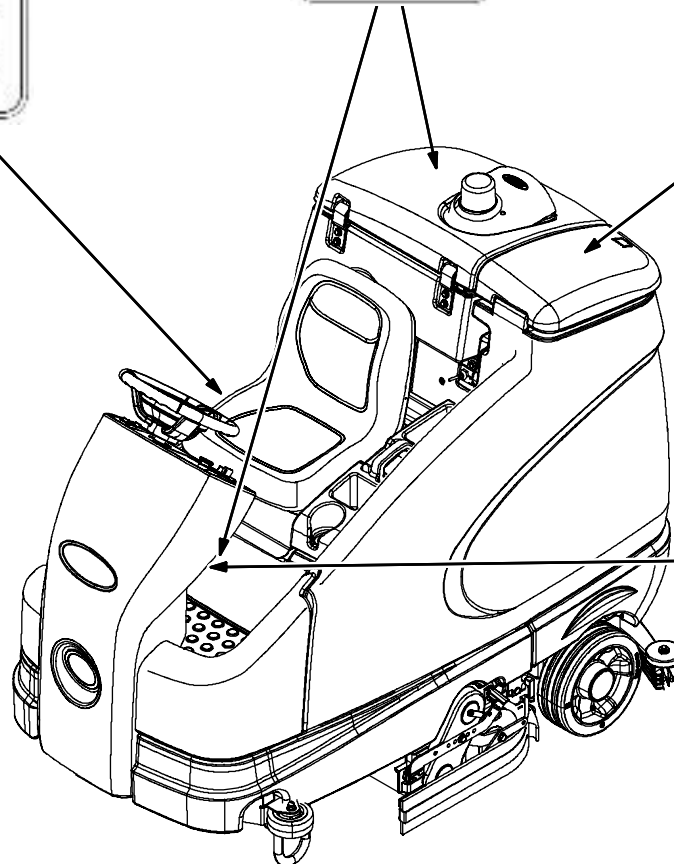

FOR SAFETY LABEL - LOCATED ON CIRCUIT BREAKER PANEL.

SECTION 2

| Contents | Page |
|---|-------------|
| General Information | 2-1 |
| Component Locator | 2-2 |
| Electrical Schematic, Master | 2-4 |
| Electrical Schematic Symbols | 2-10 |
| Operational Matrix | 2-11 |
| Specifications | 2-14 |
| Fastener Torque | 2-14 |
| General Machine Dimensions/ Capacities | 2-15 |
| General Machine Performance | 2-15 |
| Power Type | 2-16 |
| Tires | 2-16 |
| FaST System (Option) | 2-17 |
| ec-H2O System (Option) | 2-17 |
| Electrical Components | 2-17 |
| Machine Dimensions | 2-19 |

GENERAL INFORMATION

COMPONENT LOCATOR

| Components | |
|------------|--|
| A | FaST, ec-H2O System Components* |
| B | Onboard Battery Charger* |
| C | FaST, ec-H2O, Side Brush, ES, Spray Nozzle Pumps* |
| D | M1 and M2* Contactors, Diodes (D-1, D-4, D-5*) |
| E | FU-1 and FU-2 Fuses |
| F | Wheel Drive Assembly (Motor, Encoder, Temp Sender) |
| G | Logic Board |
| H | Detergent Metering Tank* |
| I | Circuit Breakers (1-10) |
| J | Solution Tank |
| K | Vacuum Fan Housing |
| L | Rear Squeegee Lift Actuator |
| M | Detergent Metering Pump* |
| N | Side Brush Motor* |
| O | Throttle/Brake Sensor |
| P | Curtis 1234 Controller |
| Q | Circuit Breakers (11-19) |
| R | Recovery Tank |

* Optional Equipment

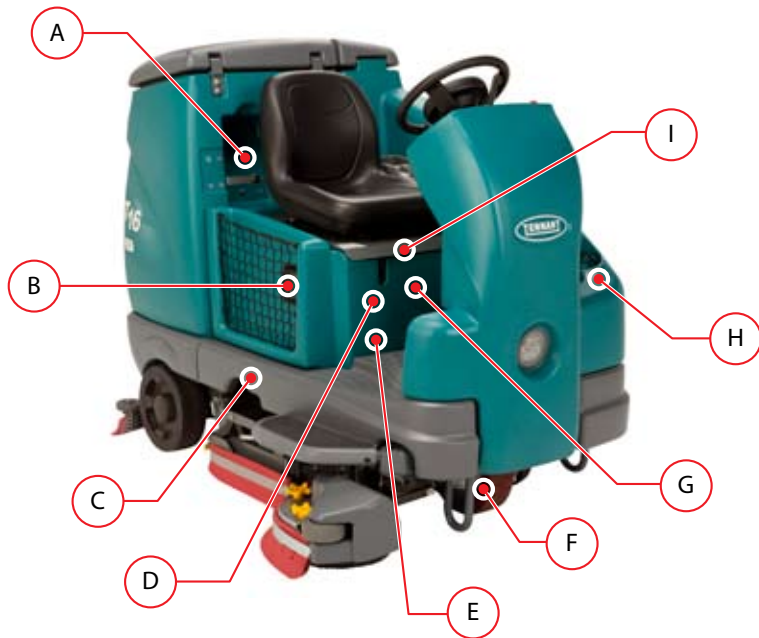

COMPONENT LOCATOR, continued

| Components | |
|------------|---------------------------------|
| S | Diodes (D-6 and D-9)* |
| T | M3 and M4 Pre-Sweep Contactors* |
| U | RH Side Brush Motor* |
| V | Pre-Sweep Main Broom Motor* |
| W | LH Side Brush Motor* |
| X | Pre-Sweep Vacuum Fan* |
| Y | Pre-Sweep Lift Actuator* |
| Z | Diodes (D-2, D-3, D-10*) |
| AA | Side Brush Lift Actuator* |
| BB | Main Brush Lift Actuator |
| CC | Conventional Water Valve |
| DD | Solution Tank Level Sensor |
| EE | Main Brush Motors |

* Optional Equipment

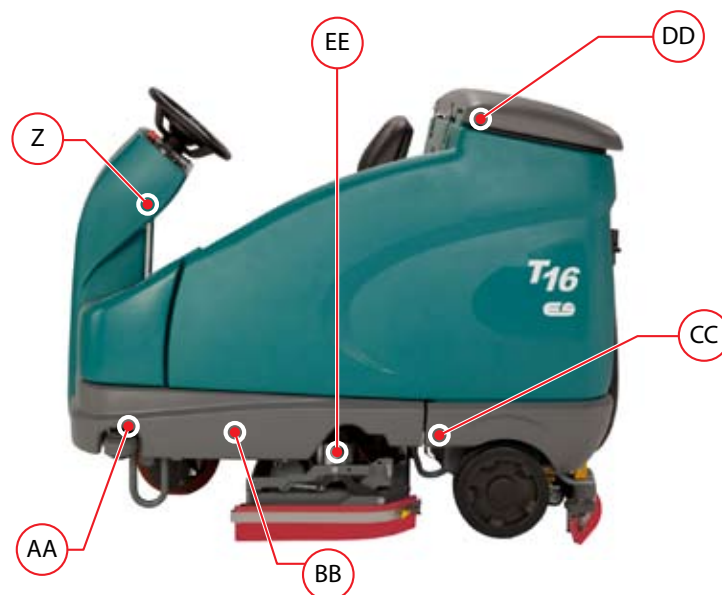

GENERAL INFORMATION

ELECTRICAL SCHEMATIC (1 of 6)

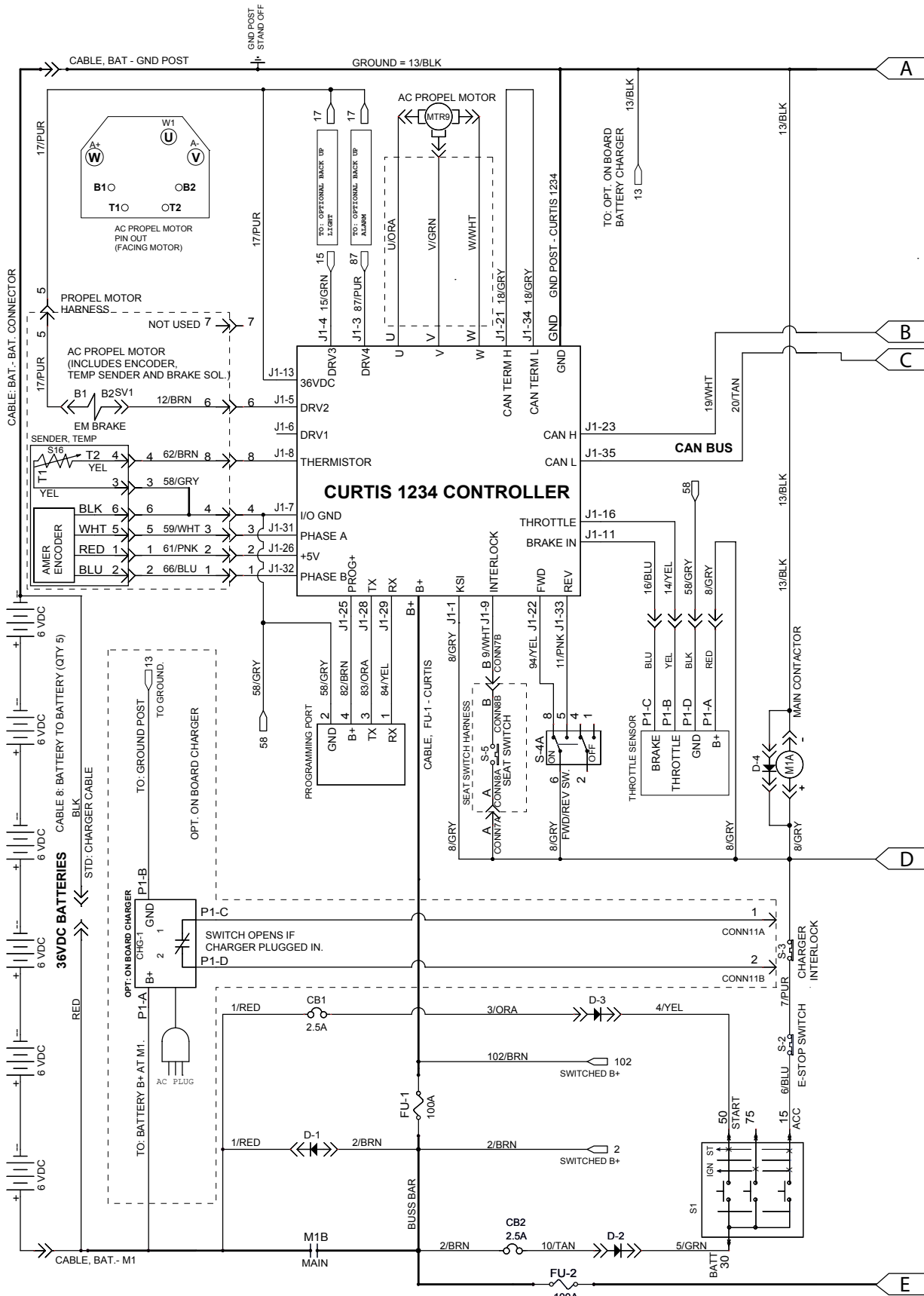

ELECTRICAL SCHEMATIC (2 of 6)

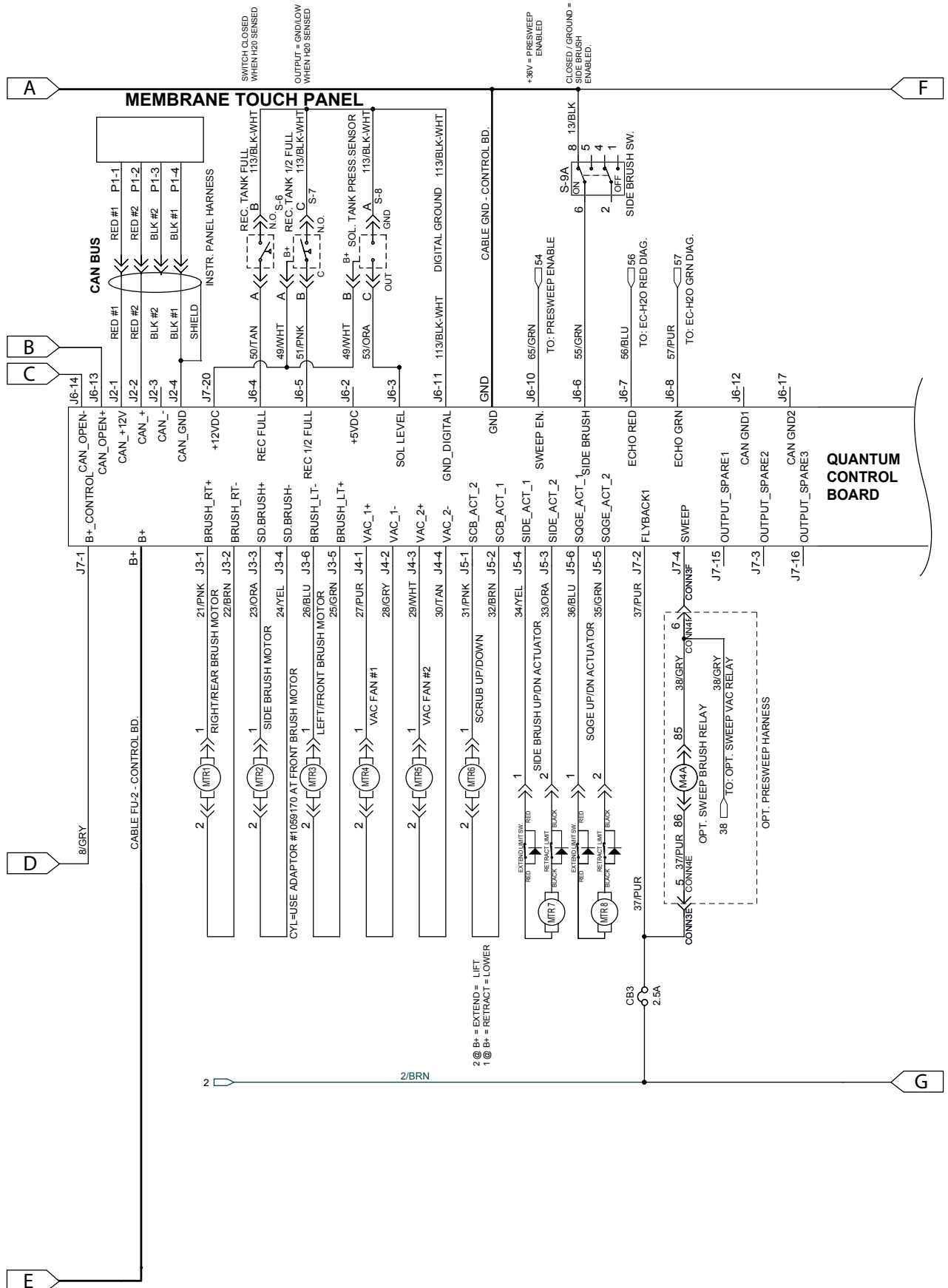

GENERAL INFORMATION

ELECTRICAL SCHEMATIC (3 of 6)

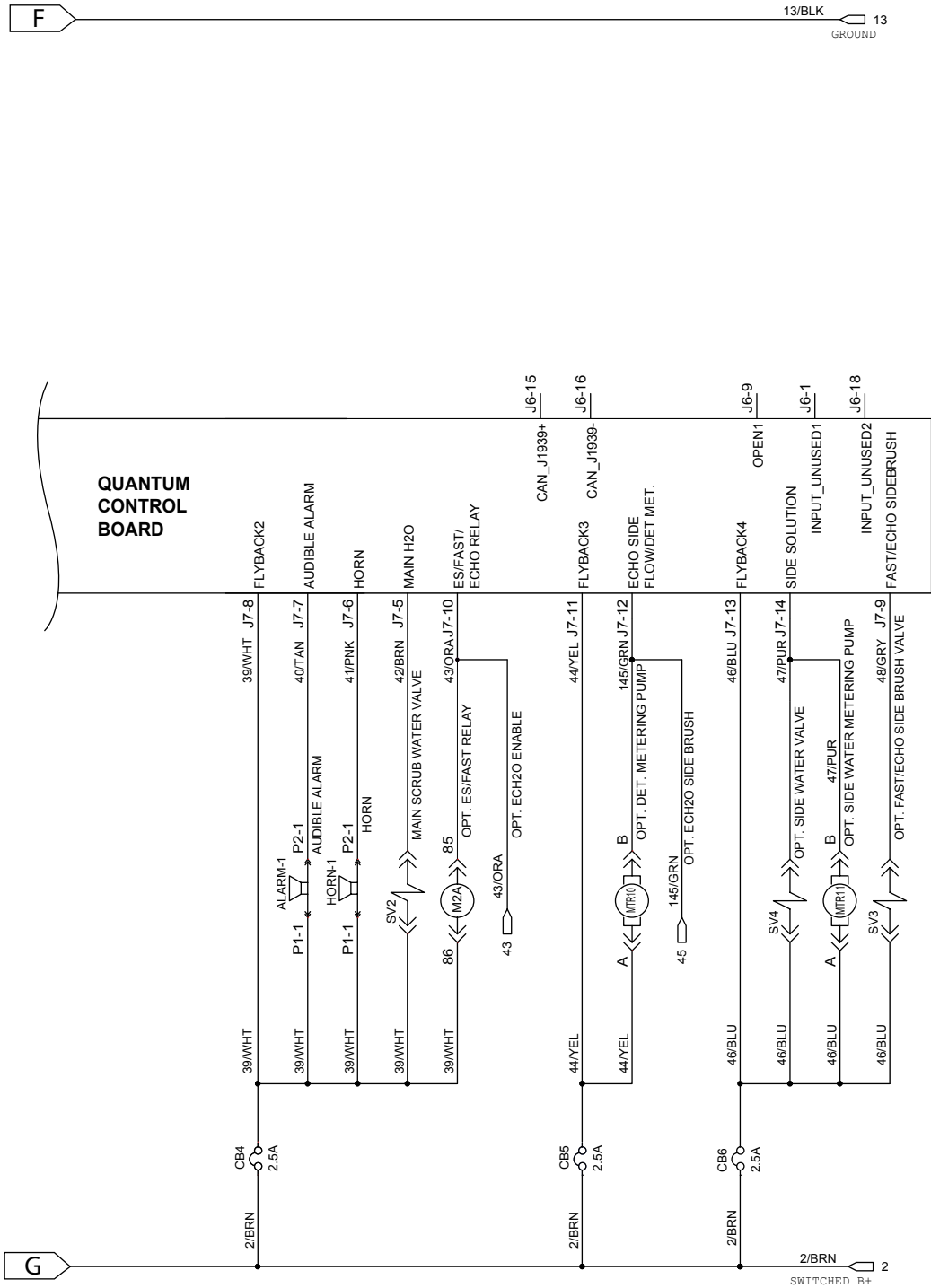

ELECTRICAL SCHEMATIC (4 of 6)

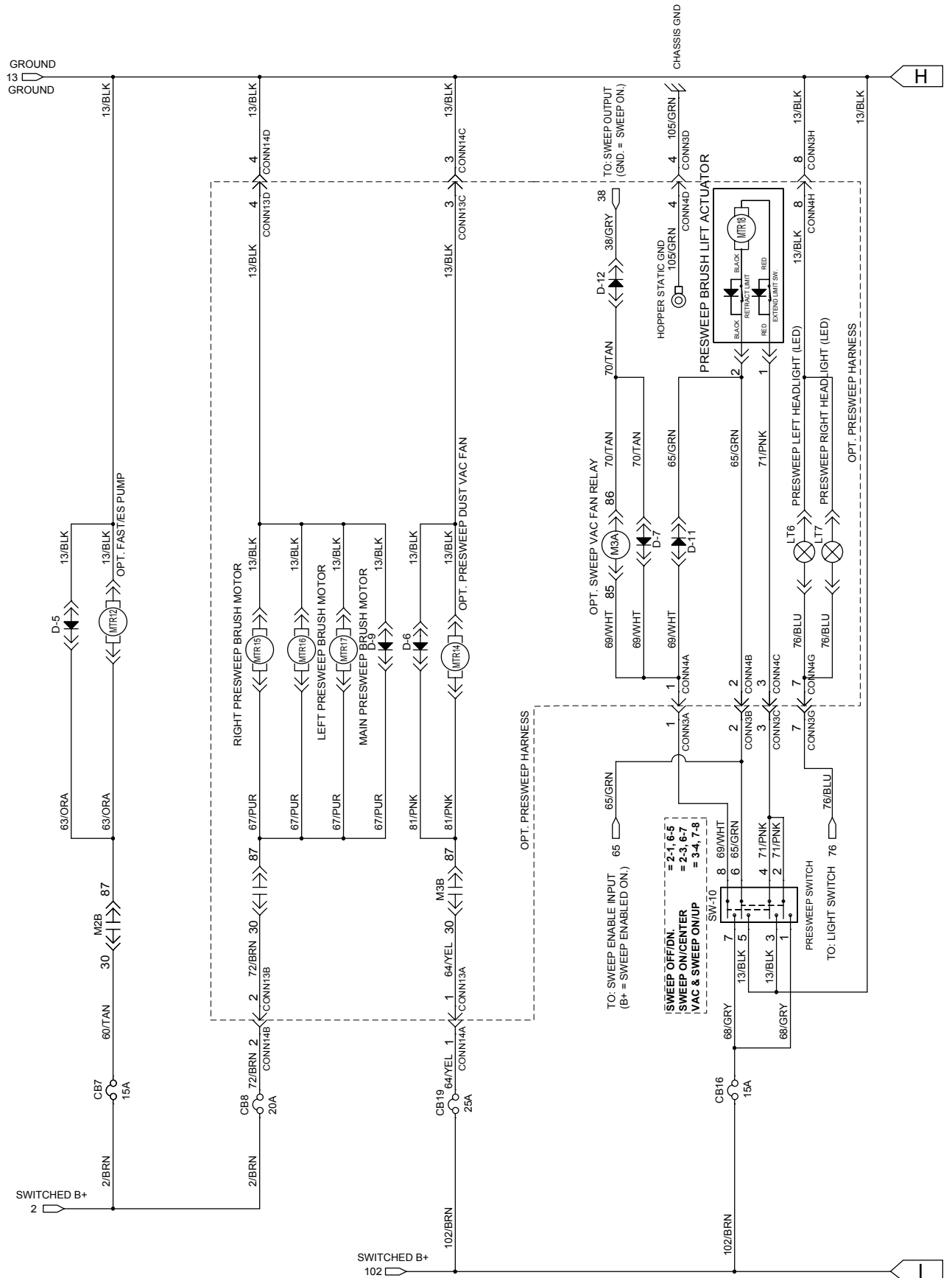

GENERAL INFORMATION

ELECTRICAL SCHEMATIC (5 of 6)

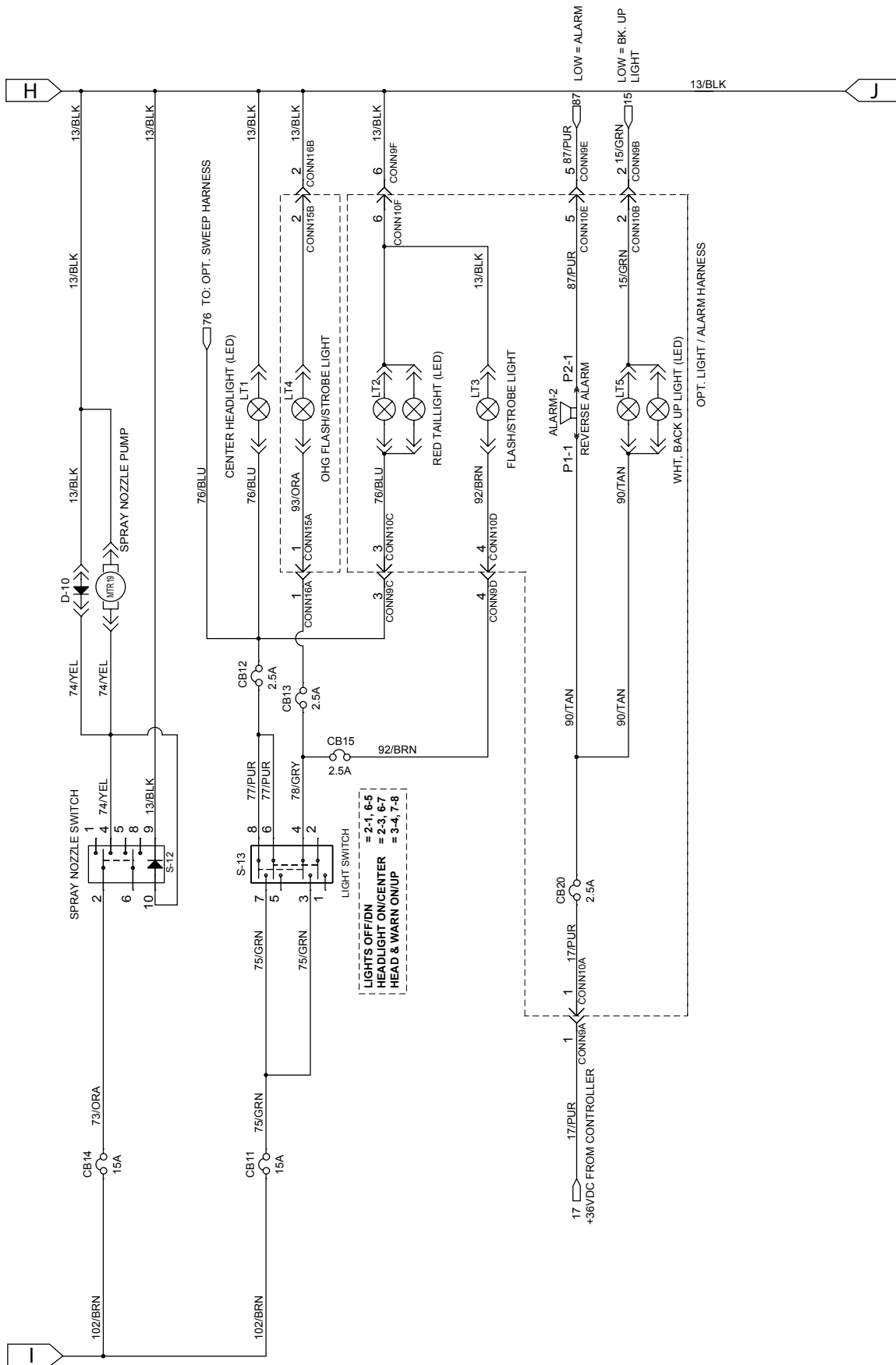

ELECTRICAL SCHEMATIC (6 of 6)

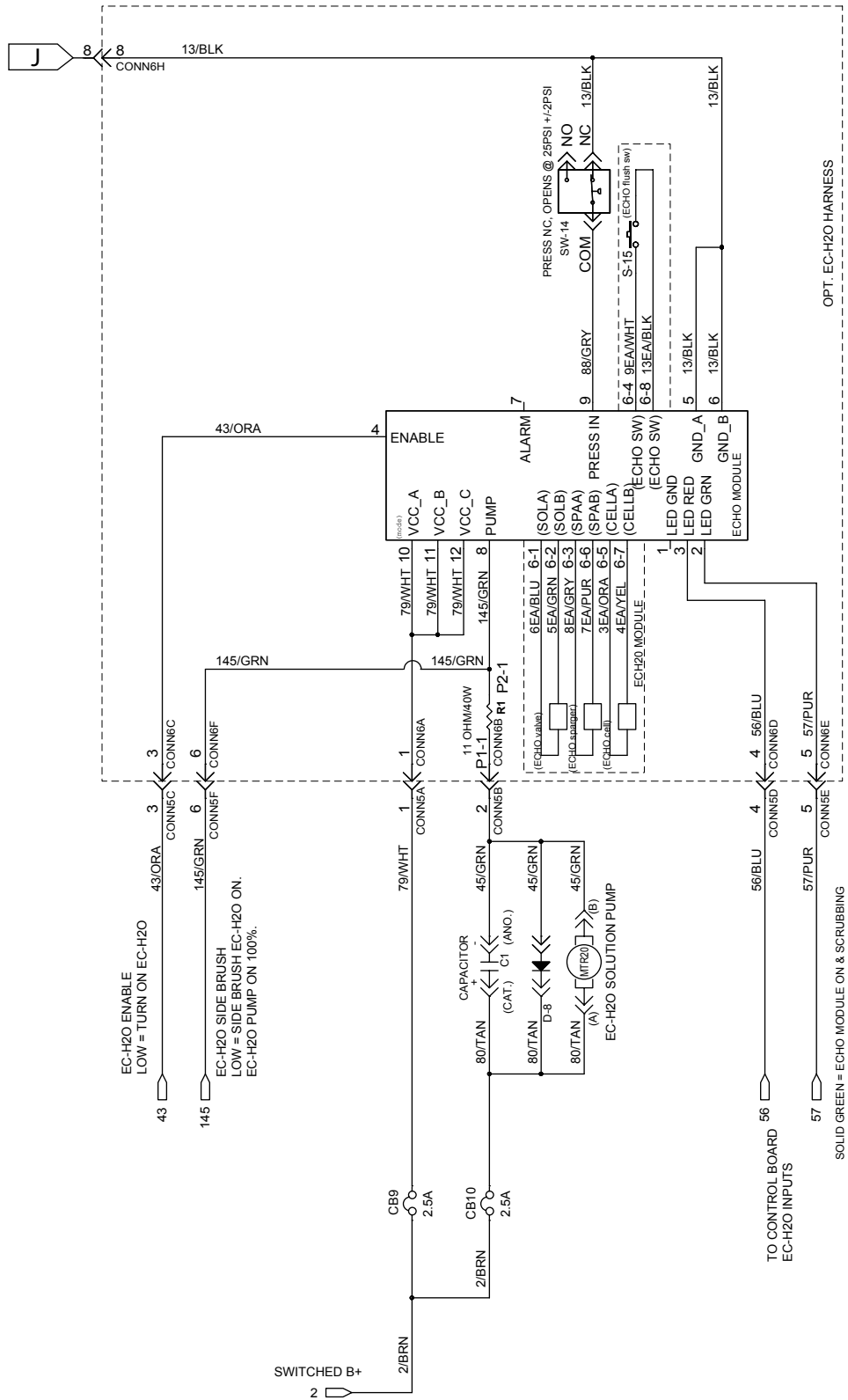

EC-H2O ENABLE
LOW = TURN ON EC-H2O

EC-H2O SIDE BRUSH
LOW = SIDE BRUSH EC-H2O ON.
EC-H2O PUMP ON 100%.

SOLID GREEN = ECHO MODULE ON & SCRUBBING
SOLID RED = OVER CURRENT OF SOLUTION PUMP OR SPARGER
FLASHING RED = PRESSURE SWITCH CLOSED *E-CELL IS SCALED UP*

GENERAL INFORMATION

ELECTRICAL SCHEMATIC SYMBOLS

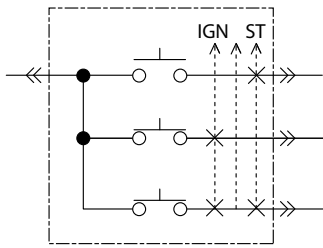

Key Switch

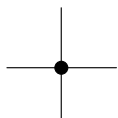

Connected

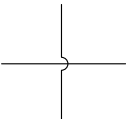

Not Connected

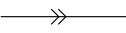

Connector



Energized

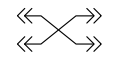

Adaptor Harness



Notes



Assembly

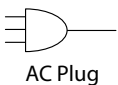

AC Plug

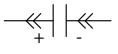

Capacitor



Battery



Circuit Breaker



Fuse



Diode

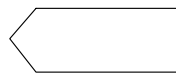

Single Continuation Tab

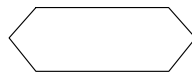

Double Continuation Tab

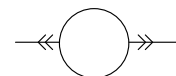

Relay Coil

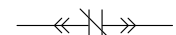

N.C. Relay Contacts

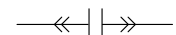

N.O. Relay Contacts



Horn or Alarm



Light

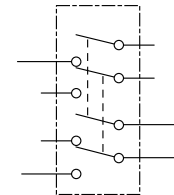

DPDT Switch

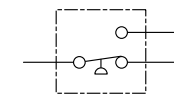

Pressure Switch



Motor

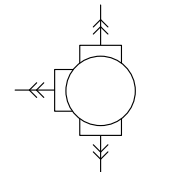

3 Phase AC Induction Motor

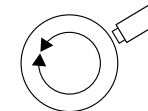

Motor Encoder



Sensor
(Variable Resistor)



Momenary Switch N.O.

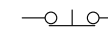

Contact Switch N.C.

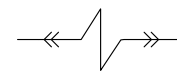

Solenoid Valve

OPERATIONAL MATRIX

| T16 OPERATIONAL MATRIX | | |
|---|--|--|
| FUNCTION | ENABLED | DISABLED |
| Vacuum Fan(s), Scrubbing | <ul style="list-style-type: none"> • 1-STEP Scrub ON • Squeegee/Vacuum ON | <ul style="list-style-type: none"> • 1-STEP Scrub OFF • Squeegee/Vacuum OFF • Recovery Tank Full • Very Low Battery Voltage • Load Current Fault |
| Rear Squeegee Down | <ul style="list-style-type: none"> • 1-STEP Scrub ON • Squeegee/Vacuum ON | <ul style="list-style-type: none"> • 1-STEP Scrub OFF • Squeegee/Vacuum OFF • Reverse Propel • Recovery Tank Full • Very Low Battery Voltage • Load Current Fault |
| Rear Squeegee Up | <ul style="list-style-type: none"> • 1-STEP Scrub OFF • Squeegee/Vacuum OFF • Reverse Propel • Recovery Tank Full • Very Low Battery Voltage • Load Current Fault | <ul style="list-style-type: none"> • 1-STEP Scrub ON • Squeegee/Vacuum ON |
| Main Scrub Brushes | <ul style="list-style-type: none"> • 1-STEP Scrub ON • Fwd/Rev Throttle Command | <ul style="list-style-type: none"> • 1-STEP Scrub OFF • Neutral - Ready State • Recovery Tank Full • Solution Tank Empty • Very Low Battery Voltage • Load Current Fault |
| Scrub Head Down | <ul style="list-style-type: none"> • 1-STEP Scrub ON • Fwd/Rev Throttle Command | <ul style="list-style-type: none"> • 1-STEP Scrub OFF • Neutral - Ready State • Recovery Tank Full • Solution Tank Empty • Very Low Battery Voltage • Load Current Fault |
| Scrub Head Up | <ul style="list-style-type: none"> • 1-STEP Scrub OFF • Neutral - Ready State • Recovery Tank Full • Solution Tank Empty • Very Low Battery Voltage • Load Current Fault | <ul style="list-style-type: none"> • 1-STEP Scrub ON • Fwd/Rev Throttle Command |
| Side Brush Extend/Down (Non Pre-Sweep) | <ul style="list-style-type: none"> • 1-STEP Scrub ON • Side Brush Switch ON | <ul style="list-style-type: none"> • 1-STEP Scrub OFF • Side Brush Switch OFF • Recovery Tank Full • Solution Tank Empty • Very Low Battery Voltage • Load Current Fault |

MOM001

GENERAL INFORMATION

OPERATIONAL MATRIX, continued

T16 OPERATIONAL MATRIX, continued

| FUNCTION | ENABLED | DISABLED |
|--|--|--|
| Side Brush Retract/Up (Non Pre-Sweep) | <ul style="list-style-type: none"> • 1-STEP Scrub OFF • Side Brush Switch OFF • Recovery Tank Full • Solution Tank Empty • Very Low Battery Voltage • Load Current Fault | <ul style="list-style-type: none"> • 1-STEP Scrub ON • Side Brush Switch ON |
| Side Brush (Non Pre-Sweep) | <ul style="list-style-type: none"> • 1-STEP Scrub ON • Side Brush Switch ON • Fwd/Rev Throttle Command | <ul style="list-style-type: none"> • 1-STEP Scrub OFF • Side Brush Switch OFF • Neutral - Ready State • Recovery Tank Full • Solution Tank Empty • Very Low Battery Voltage • Load Current Fault |
| Solution Control (Conventional) | <ul style="list-style-type: none"> • 1-STEP Scrub ON • Solution Control ON • Fwd/Rev Throttle Command | <ul style="list-style-type: none"> • 1-STEP Scrub OFF • Solution Control OFF • Neutral - Ready State • Recovery Tank Full • Solution Tank Empty • Very Low Battery Voltage • Load Current Fault |
| Solution Control (FaST) | <ul style="list-style-type: none"> • 1-STEP Scrub ON • Solution Control ON • FaST Button ON • Fwd/Rev Throttle Command | <ul style="list-style-type: none"> • 1-STEP Scrub OFF • Solution Control OFF • FaST Button OFF • Neutral - Ready State • Recovery Tank Full • Solution Tank Empty • Very Low Battery Voltage • Load Current Fault |
| Solution Control (ecH2O) | <ul style="list-style-type: none"> • 1-STEP Scrub ON • Solution Control ON • ecH2O Button ON • Fwd/Rev Throttle Command | <ul style="list-style-type: none"> • 1-STEP Scrub OFF • Solution Control OFF • ecH2O Button OFF • Neutral - Ready State • Recovery Tank Full • Solution Tank Empty • Very Low Battery Voltage • ecH2O System Fault • Load Current Fault |
| Extended Scrub | <ul style="list-style-type: none"> • 1-STEP Scrub ON • Solution Control ON • ES Button ON • Recovery Tank 1/2 Full | <ul style="list-style-type: none"> • 1-STEP Scrub OFF • Solution Control OFF • ES Button OFF • Recovery Tank Full • Solution Tank Full • Very Low Battery Voltage • Load Current Fault |

MOM002

OPERATIONAL MATRIX, continued

| T16 OPERATIONAL MATRIX, continued | | |
|--|---|---|
| FUNCTION | ENABLED | DISABLED |
| Detergent Metering | <ul style="list-style-type: none"> • 1-STEP Scrub ON • Solution Control ON (Conventional Only) • 2 or 3 Solution LEDs ON • Fwd/Rev Throttle Command | <ul style="list-style-type: none"> • 1-STEP Scrub OFF • Solution Control OFF • 0 or 1 Solution LEDs ON • Neutral - Ready State • Recovery Tank Full • Solution Tank Empty • Very Low Battery Voltage • Load Current Fault |
| Pre-Sweep Brushes | <ul style="list-style-type: none"> • Pre-Sweep Switch ON • Fwd/Rev Throttle Command | <ul style="list-style-type: none"> • Pre-Sweep Switch OFF • Neutral - Ready State • Very Low Battery Voltage • Load Current Fault |
| Pre-Sweep Brushes Down | <ul style="list-style-type: none"> • Pre-Sweep Switch ON | <ul style="list-style-type: none"> • Pre-Sweep Switch OFF |
| Pre-Sweep Brushes UP | <ul style="list-style-type: none"> • Pre-Sweep Switch OFF | <ul style="list-style-type: none"> • Pre-Sweep Switch ON |
| Pre-Sweep Vacuum Fan | <ul style="list-style-type: none"> • Pre-Sweep/Vacuum Fan Switch ON • Fwd/Rev Throttle Command | <ul style="list-style-type: none"> • Pre-Sweep/Vacuum Fan Switch OFF • Neutral - Ready State • Very Low Battery Voltage • Load Current Fault |
| Propel | <ul style="list-style-type: none"> • Seat Switch Closed • Fwd/Rev Throttle Command • Fwd/Rev Switch Input | <ul style="list-style-type: none"> • Seat Switch Open • Neutral - Ready State • Brake Command • Curtis 1234 Fault |
| Electromagnetic Parking Brake | <ul style="list-style-type: none"> • Key OFF • Emergency Stop Switch Open (Down) • Neutral (1-2 Second Delay) • Seat Switch Open • Curtis 1234 Fault | <ul style="list-style-type: none"> • Key ON • Emergency Stop Switch Closed (Up) • Fwd/Rev Throttle Command • Seat Switch Closed |
| Back-Up Alarm/Lights | <ul style="list-style-type: none"> • Reverse Switch Input • Reverse Throttle Command | <ul style="list-style-type: none"> • Forward Switch Input • Neutral - Ready State • Curtis 1234 Fault |

MOM003

GENERAL INFORMATION

FASTENER TORQUE

SAE (STANDARD)

| Thread Size | SAE Grade 1 | SAE Grade 2 Carriage Bolts | Thread Cutting Thread Rolling | SAE Grade 5 Socket & Stainless Steel | SAE Grade 8 | Headless Socket Set Screws | Square Head Set Screws |
|-------------|-------------|----------------------------|-------------------------------|--------------------------------------|-------------|----------------------------|------------------------|
| 4 (.112) | (5) - (6.5) | | | | | (4) - (6) | |
| 5 (.125) | (6) - (8) | | | | | (9) - (11) | |
| 6 (.138) | (7) - (9) | | (20) - (24) | | | (9) - (11) | |
| 8 (.164) | (12) - (16) | | (40) - (47) | | | (17) - (23) | |
| 10 (.190) | (20) - (26) | | (50) - (60) | | | (31) - (41) | |
| 1/4 (.250) | 4 - 5 | 5 - 6 | 7 - 10 | 7 - 10 | 10 - 13 | 6 - 8 | 17 - 19 |
| 5/16 (.312) | 7 - 9 | 9 - 12 | 15 - 20 | 15 - 20 | 20 - 26 | 13 - 15 | 32 - 38 |
| 3/8 (.375) | 13 - 17 | 16 - 21 | | 27 - 35 | 36 - 47 | 22 - 26 | 65 - 75 |
| 7/16 (.438) | 20 - 26 | 26 - 34 | | 43 - 56 | 53 - 76 | 33 - 39 | 106 - 124 |
| 1/2 (.500) | 27 - 35 | 39 - 51 | | 65 - 85 | 89 - 116 | 48 - 56 | 162 - 188 |
| 5/8 (.625) | | 80 - 104 | | 130 - 170 | 171 - 265 | | 228 - 383 |
| 3/4 (.750) | | 129 - 168 | | 215 - 280 | 313 - 407 | | 592 - 688 |
| 1 (1.000) | | 258 - 335 | | 500 - 650 | 757 - 984 | | 1281 - 1489 |

METRIC

| Thread Size | 4.8/5.6 | 8.8 Stainless Steel | 10.9 | 12.9 | Set Screws |
|-------------|---------------|---------------------|---------------|----------------|----------------|
| M3 | 43 - 56 Ncm | 99 - 128 Ncm | 139 - 180 Ncm | 166 - 215 Ncm | 61 - 79 Ncm |
| M4 | 99 - 128 Ncm | 223 - 290 Ncm | 316 - 410 Ncm | 381 - 495 Ncm | 219 - 285 Ncm |
| M5 | 193 - 250 Ncm | 443 - 575 Ncm | 624 - 810 Ncm | 747 - 970 Ncm | 427 - 554 Ncm |
| M6 | 3.3 - 4.3 Nm | 7.6 - 9.9 Nm | 10.8 - 14 Nm | 12.7 - 16.5 Nm | 7.5 - 9.8 Nm |
| M8 | 8.1 - 10.5 Nm | 18.5 - 24 Nm | 26.2 - 34 Nm | 31 - 40 Nm | 18.3 - 23.7 Nm |
| M10 | 16 - 21 Nm | 37 - 48 Nm | 52 - 67 Nm | 63 - 81 Nm | |
| M12 | 28 - 36 Nm | 64 - 83 Nm | 90 - 117 Nm | 108 - 140 Nm | |
| M14 | 45 - 58 Nm | 102 - 132 Nm | 142 - 185 Nm | 169 - 220 Nm | |
| M16 | 68 - 88 Nm | 154 - 200 Nm | 219 - 285 Nm | 262 - 340 Nm | |
| M20 | 132 - 171 Nm | 300 - 390 Nm | 424 - 550 Nm | 508 - 660 Nm | |
| M22 | 177 - 230 Nm | 409 - 530 Nm | 574 - 745 Nm | 686 - 890 Nm | |
| M24 | 227 - 295 Nm | 520 - 675 Nm | 732 - 950 Nm | 879 - 1140 Nm | |

SPECIFICATIONS

GENERAL MACHINE DIMENSIONS/CAPACITIES

| Item | Dimension/Capacity |
|---|-----------------------------|
| Length | 1880 mm (74 in) |
| Length (with Pre-Sweep) | 2510 mm (99 in) |
| Width (less squeegee) | 1040 mm (41 in) |
| Width (with squeegee frame) | 1070 mm (42 in) |
| Width (with side brush) | 1170 mm (46 in) |
| Height | 1475 mm (58 in) |
| Height with overhead guard | 2080 mm (82 in) |
| Disk brush diameter for side brush (option) | 330 mm (13 in) |
| Disk brush diameter for Pre-Sweep (option) | 460 mm (18 in) |
| Disk brush diameter | 460 mm (18 in) |
| Cylindrical sweep brush diameter for Pre-Sweep (option) | 200 mm (8 in) |
| Cylindrical sweep brush length for Pre-Sweep (option) | 610 mm (24 in) |
| Cylindrical scrub brush diameter | 205 mm (8 in) |
| Cylindrical brush length | 910 mm (36 in) |
| Scrubbing path width | 910 mm (36 in) |
| Cleaning path width (with scrubbing side brush) | 1145 mm (45 in) |
| Cleaning path width (with sweeping side brush - cylindrical only) | 1170 mm (46 in) |
| Cleaning path width (with dual side brushes - Pre-Sweep only) | 1170 mm (46") |
| Solution tank capacity | 190 L (50 gallons) |
| Solution tank capacity (with optional ES system) | 280 L (75 gallons) |
| Recovery tank capacity | 227 L (60 gallons) |
| Pre-Sweep hopper capacity | 42 L (1.5 ft ³) |
| Pre-Sweep dust bag capacity | 28 L (1.0 ft ³) |
| Weight (Empty) | 500 Kg (1100 lbs) |
| Weight (with standard 235 AH batteries) | 860 Kg (1900 lbs) |
| GVWR | 1270 Kg (2800 lbs) |

GENERAL MACHINE PERFORMANCE

| Item | Measure |
|--|---------------------------------|
| Aisle turnaround width | 2110 mm (83 in) |
| Aisle turnaround width (with Pre-Sweep) | 2620 mm (103 in) |
| Travel Speed (Forward) | 9.6 Km (5.6 mph) |
| Travel Speed (Reverse) | 4 Km (2.5 mph) |
| Maximum rated climb and descent angle for transport | 8° / 14% |
| Maximum rated climb and descent angle for scrubbing | 4° / 7% |
| Maximum rated climb and descent angle for trailering | 11° / 20% |
| Sound level at operator's ear (economy mode) | Disk 68 dBA, Cylindrical 71 dBA |

GENERAL INFORMATION

SPECIFICATIONS

GENERAL MACHINE PERFORMANCE

| Item | Measure |
|--------------------------------------|--|
| Runtime (economy mode) | 235 AH, Up to 2 hours 360 AH, Up to 4 hours |
| Ground clearance (transport) | 65 mm (2.5 in) |
| Vacuum fan speed | 14000 RPM |
| Vacuum fan water lift | 1650 mm (65 in) |
| Disk main brush speed | 300 RPM |
| Disk main brush down pressure | Up to 114 kg (250 lb) |
| Cylindrical main brush speed | 500 RPM |
| Cylindrical main brush down pressure | Up to 91 kg (200 lb) |

POWER TYPE

| Type | Quantity | Volts | Ah Rating | Weight |
|-----------|----------|-------|------------------|---------------|
| Batteries | 6 | 36 | 235 @ 20 hr rate | 30 kg (67 lb) |
| | 6 | 36 | 360 @ 20 hr rate | 44 kg (98 lb) |

| Type | Use | Voltage | kW (hp) |
|-----------------|---------------------------|---------|-------------|
| Electric Motors | Pre-Sweep brush (disk) | 36 VDC | 0.20 (0.25) |
| | Pre-Sweep brush (cyl) | 36 VDC | 0.45 (0.60) |
| | Scrub brush (disk) | 36 VDC | 0.75 (1.00) |
| | Scrub brush (cylindrical) | 36 VDC | 0.75 (1.00) |
| | Vacuum Fan | 36 VDC | 0.6 (0.8) |
| | Propelling | 36 VAC | 1.2 (1.6) |

| Type | VDC | Amperage | Hz | Phase | VAC |
|------------------|-----|----------|-------|-------|--------|
| Chargers (Smart) | 36 | 21 | 45-65 | 1 | 85-265 |

TIRES

| Location | Type | Size |
|-----------|-------|--|
| Front (1) | Solid | 102 mm wide x 300 mm OD (4 in wide x 12 in OD) |
| Rear (2) | Solid | 102 mm wide x 300 mm OD (4 in wide x 12 in OD) |

SPECIFICATIONS

FaST SYSTEM (OPTION)

| Item | Measure |
|---|--|
| Solution pump | 36 Volt DC, 5A, 5.7 LPM (1.5 GPM) open flow, 45 psi bypass setting |
| Solution flow rate (at main brushes) | 1.1 LPM (0.30 GPM) |
| Solution flow rate (at side brush - if machine is equipped with optional side brush) | 0.49 LPM (0.13 GPM) |
| Detergent flow rate (at main brushes) | 1.14 CC/Minute (0.038 Ounces/Minute) |
| Detergent flow rate (at side brush - if machine is equipped with optional side brush) | 0.47 CC/Minute (0.016 Ounces/Minute) |

ec-H2O SYSTEM (OPTION)

| Item | Measure |
|---|--|
| Solution pump | 36 Volt DC, 5A, 5.7 LPM (1.5 GPM) open flow, 45 psi bypass setting |
| Solution flow rate (machines without optional side brush) | 2.35 LPM (0.62 GPM) |
| Solution flow rate (machines with optional side brush) | 2.35 LPM (0.62 GPM) - (To main scrub head) |
| | 1.06 LPM (0.28 GPM) - (To side brush) |

ELECTRICAL COMPONENTS *(For Reference Only)*

| Component | Measure |
|---|--|
| Contactors Coil, M1 | 102 Ω +/- 5% |
| Contactors Coil, M2 | 160 Ω +/- 5% |
| Contactors Coil, M3 | 160 Ω +/- 5% |
| Contactors Coil, M4 | 160 Ω +/- 5% |
| Actuator, Scrub head lift | 1 - 3 Amps Continuous |
| Actuator, Side brush lift | 1 - 3 Amps continuous, Internal limit switches |
| Actuator, Pre-Sweep brushes lift | 1 - 3 Amps Continuous, Internal limit switches |
| Actuator, Rear squeegee lift | 2 - 4 Amps Continuous, Internal limit switches |
| Motor, Vacuum Fan(s) | 14 - 20 Amps Continuous |
| Motor, Propelling (5.6 mph transport speed) | 15 - 25 Amps Continuous, 40-60 Amps Peak |
| Motors, Main disk brush | |
| Down pressure #1 | 11 Amps/Motor (Fixed) |
| Down pressure #2 | 11 - 16 Amps/Motor (default 16 Amps) |
| Down pressure #3 | 11 - 22 Amps/Motor (default 22 Amps) |
| Motors, Main cylindrical brush | |
| Down pressure #1 | 11 Amps/Motor (Fixed) |
| Down pressure #2 | 11 - 16 Amps/Motor (default 16 Amps) |
| Down pressure #3 | 11 - 22 Amps/Motor (default 22 Amps) |

GENERAL INFORMATION

SPECIFICATIONS

ELECTRICAL COMPONENTS *(For Reference Only)*

| Component | Measure |
|---------------------------------------|---------------------|
| Motor, Side Brush (non Pre-Sweep) | 5 - 8 Amps |
| Pump, ES | 2 - 4 Amps |
| Pump, <i>ec-H2O</i> | 4 - 6 Amps |
| Pump, FaST | 4 - 6 Amps |
| Pump, Spray Nozzle | 2 - 3 Amps |
| Pump, Detergent | 3 - 5 Amps |
| Pump, Side Brush | 0.5 - 2 Amps |
| Valve, FaST/ <i>ec-H2O</i> Side Brush | 129 Ω +/- 5% |
| Valve, Conventional Side Brush | 127 Ω +/- 5% |
| Valve, Conventional Main Brush | 103 Ω +/- 5% |

SPECIFICATIONS

MACHINE DIMENSIONS

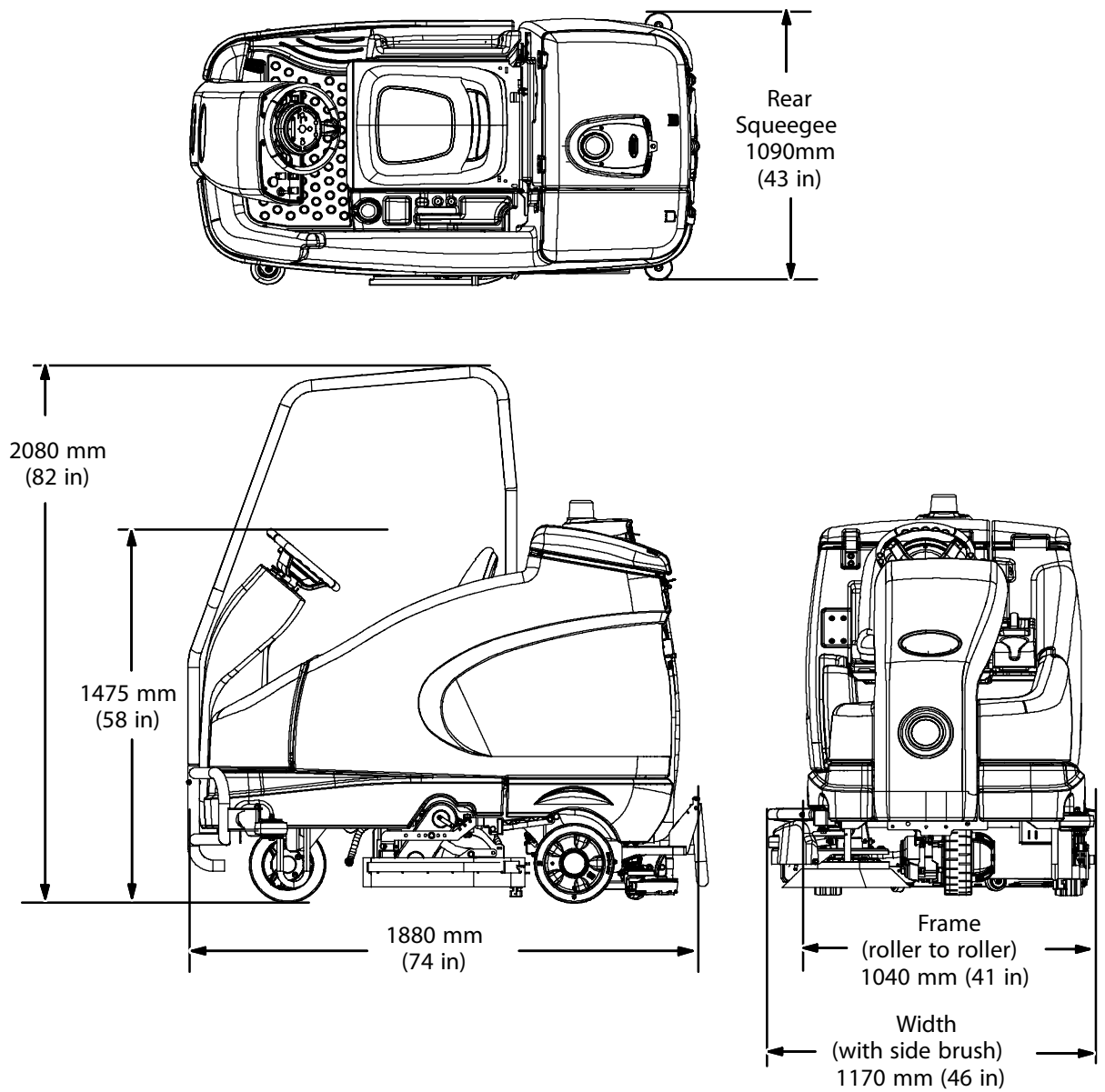

SECTION 3

| Contents | Page |
|---|-------------|
| Maintenance | |
| Maintenance Chart..... | 3-2 |
| Lubrication | 3-4 |
| Steering Chain | 3-4 |
| Rear Squeegee Casters | 3-4 |
| Steering Gear Chain..... | 3-4 |
| Batteries | 3-5 |
| Charging the Batteries (Off-Board Charger) | 3-6 |
| Charging the Batteries (Onboard Charger) | 3-7 |
| Circuit Breakers | 3-8 |
| Electric Motors | 3-8 |
| Scrub Brushes..... | 3-9 |
| Disk Brushes and Pads..... | 3-9 |
| Replacing Disk Brushes (or Pad Drivers)..... | 3-9 |
| Replacing Disk Scrub Pads..... | 3-10 |
| Cylindrical Brushes | 3-11 |
| Replacing Cylindrical Brushes..... | 3-11 |
| Checking Cylindrical Scrub Brush Pattern | 3-12 |
| Adjusting Cylindrical Brush Taper | 3-15 |
| Adjusting Cylindrical Brush Pattern Width..... | 3-16 |
| Side Brush (Option) | 3-17 |
| Replacing the Side Brush | 3-17 |
| Pre-Sweep Brushes..... | 3-18 |
| Replacing the Pre-Sweep Disk Brushes.. | 3-18 |
| Replacing the Pre-Sweep Cylindrical Brush | 3-19 |
| Checking and Adjusting Pre-Sweep Cylindrical Brush Pattern | 3-20 |
| FaST | 3-24 |
| Replacing the FaST-Pak Carton..... | 3-24 |
| Cleaning the FaST Supply Hose Connector | 3-24 |
| Replacing the FaST Injector Filters | 3-24 |
| ec-H2O Module Flush Procedure | 3-25 |
| Squeegee Blades..... | 3-27 |
| Replacing (or Rotating) the Rear Squeegee Blades..... | 3-27 |
| Leveling the Rear Squeegee | 3-30 |
| Adjusting the Rear Squeegee Blade Deflection | 3-31 |
| Replacing (or Rotating) the Side Squeegee Blades..... | 3-32 |
| Replacing (or Rotating) the Side | |

| Contents | Page |
|--|-------------|
| Brush Squeegee Blade(s) (Option) ... | 3-33 |
| Skirts and Seals | 3-35 |
| Pre-Sweep Side Skirts (Option) | 3-35 |
| Pre-Sweep Recirculation Skirt (Option).. | 3-35 |
| Pre-Sweep Rear Skirt (Option) | 3-35 |
| Belts and Chains | 3-36 |
| Steering Chain | 3-36 |
| Cylindrical Brush Drive Belts | 3-36 |
| Pre-Sweep Brush Drive Belt..... | 3-36 |
| Tires | 3-36 |
| Pushing, Towing, and Transporting the Machine | 3-37 |
| Pushing or Towing the Machine | 3-37 |
| Transporting the Machine | 3-37 |
| Machine Jacking | 3-39 |
| Storage Information..... | 3-39 |
| Freeze Protection (Machines without Optional ec-H2O System)..... | 3-40 |
| Preparing the Machine for Operation (Machines without Optional ec-H2O System)..... | 3-41 |
| Freeze Protection (Machines with Optional ec-H2O System)..... | 3-42 |
| Priming the ec-H2O System | 3-44 |

MAINTENANCE

MAINTENANCE

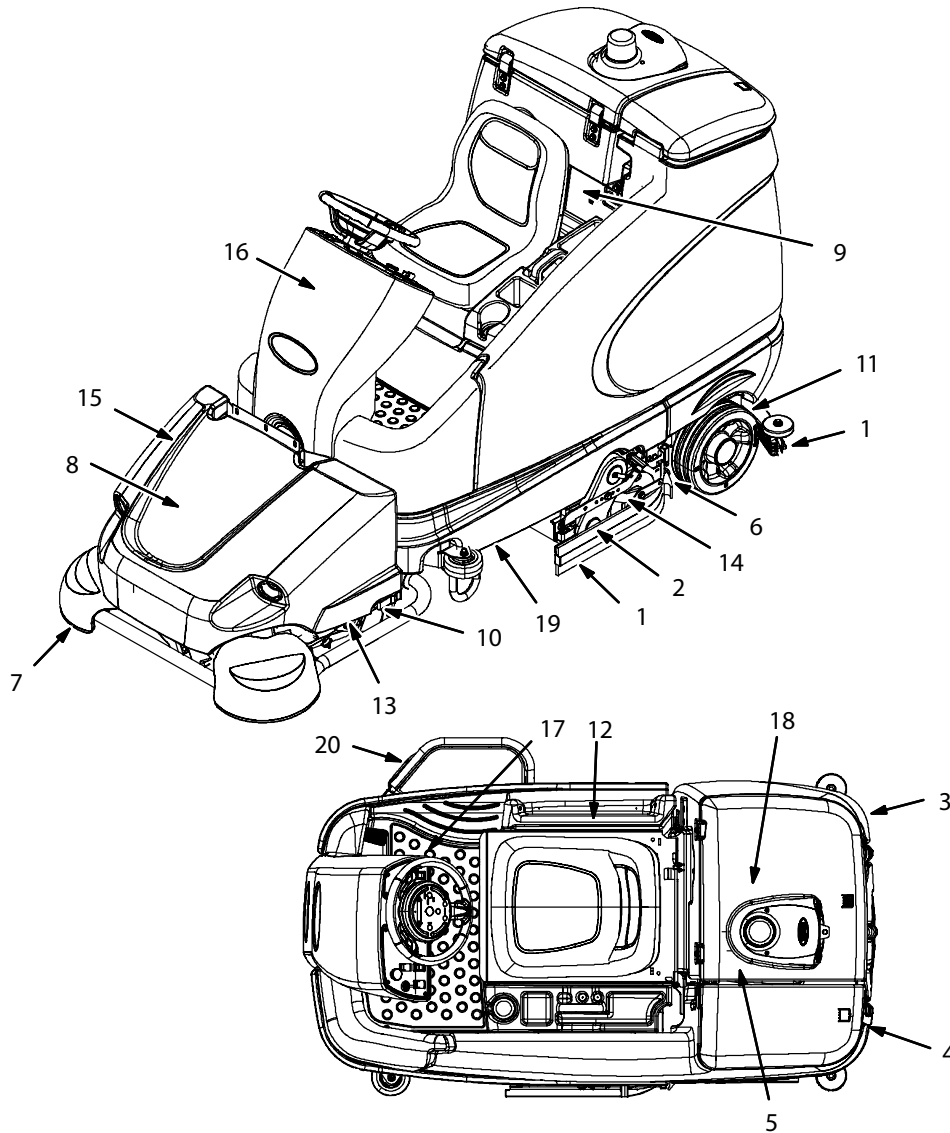

MAINTENANCE CHART

356071

| Interval | Key | Description | Procedure | Lubricant/ Fluid | No. of Service Points |
|----------|-----|--|--------------------------------|---------------------|-----------------------------|
| Daily | 1 | Side and rear squeegees | Check for damage and wear | - | 3 |
| | 2 | Main brushes | Check for damage, wear, debris | - | 2 |
| | 3 | Recovery tank | Clean tank | - | 1 |
| | 3 | Recovery tank (ES only) | Clean ES filter | - | 1 |
| | 4 | Solution tank (ES only) | Clean solution supply filter | - | 1 |
| | 5 | Vacuum fan inlet filter | Clean | - | 1 |
| | 6 | Cylindrical brushes only: Debris tray | Clean | - | 1 |

MAINTENANCE

| Interval | Key | Description | Procedure | Lubricant/ Fluid | No. of Service Points |
|------------|-----|------------------------------------|---|---------------------|-----------------------------|
| Daily | 7 | Pre-Sweep side brushes | Check for damage, wear, debris | - | 2 |
| | 10 | Pre-Sweep main brush | Check for damage, wear, debris | - | 1 |
| | 8 | Pre-Sweep debris hopper | Clean | - | 1 |
| | 20 | Side brush | Check for damage, wear, debris | - | 1 |
| | 20 | Side brush squeegee | Check for damage and wear | - | 1 |
| 50 Hours | 2 | Main Brushes (cylindrical) | Rotate brushes from front to rear | - | 2 |
| | 11 | Squeegee caster wheel pivot points | Lubricate | SPL | 4 |
| | 12 | Battery cells | Check electrolyte level | DW | 3 |
| | 1 | Side and rear squeegees | Check deflection and leveling | - | 6 |
| | 13 | Pre-Sweep skirts and seals | Check for damage and wear | - | 4 |
| | 9 | FaST/Solution filter screen | Clean | - | 1 |
| 200 Hours | 12 | Battery terminals and cables | Check and clean (after initial 50 hours only) | - | 12 |
| | 14 | Cylindrical brush drive belts | Check for damage and wear | - | 2 |
| | 15 | Pre-Sweep brush drive belt | Check for damage and wear | - | 2 |
| | 17 | Steering chain | Lubricate and check tension | GL | 1 |
| 500 Hours | 18 | Vacuum fan motor(s) | Check motor brushes | - | 1 (2) |
| | 21 | Tires | Check for damage and wear | - | 3 |
| 1000 Hours | 14 | Main brush motors | Check motor brushes (Check every 100 hours after initial 1000 hour check) | - | 2 (4) |
| | 20 | Side brush motor | Check motor brushes (Check every 100 hours after initial 1000 hour check) | - | 1 |
| | 13 | Pre-Sweep main brush motor | Check motor brushes (Check every 100 hours after initial 1000 hour check) | - | 1 |
| | 9 | FaST injector filters | Replace | - | 1 |

LUBRICANT/FLUID

DW . . . Distilled water.

SPL . . . Special lubricant, Lubriplate EMB grease (Tennant part number 01433-1)

GL . . . SAE 90 weight gear lubricant

NOTE: More frequent maintenance intervals may be required in extremely dusty conditions.

MAINTENANCE

LUBRICATION

STEERING CHAIN

The steering chain is located on the steering column directly under the control panel. Lubricate the steering chain after every 200 hours.



STEERING GEAR CHAIN

The steering gear chain is located directly above the front tire. Lubricate the steering gear chain after every 200 hours.

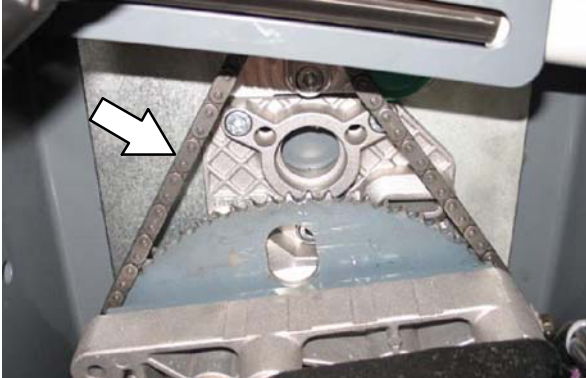

REAR SQUEEGEE CASTERS

Lubricate the rear squeegee caster pivot point on each squeegee caster after every 50 hours.

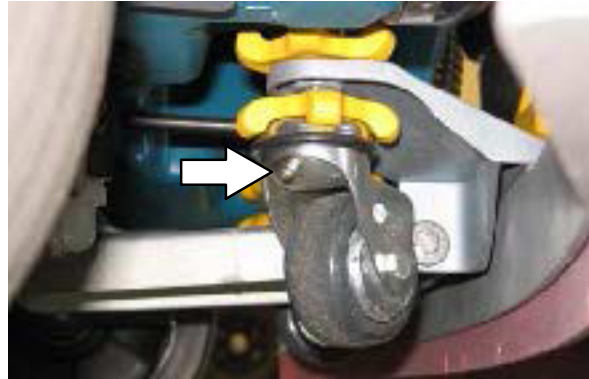

BATTERIES

The batteries are designed to hold their power for long periods of time. The lifetime of the batteries is limited to number of charges the batteries receive. To get the most life from the batteries, charge them when the last battery discharge indicator segment flashes (20% charge left). Use an automatic charger with the proper rating for the batteries.

Check the electrolyte level in each battery cell before and after charging, and after every 50 hours of operation. Do not charge the batteries unless the fluid is slightly above the battery plates. If needed, add just enough distilled water to cover the plates. Never add acid to the batteries. Do not overfill. Always keep the battery caps on, except when adding water or taking hydrometer readings.

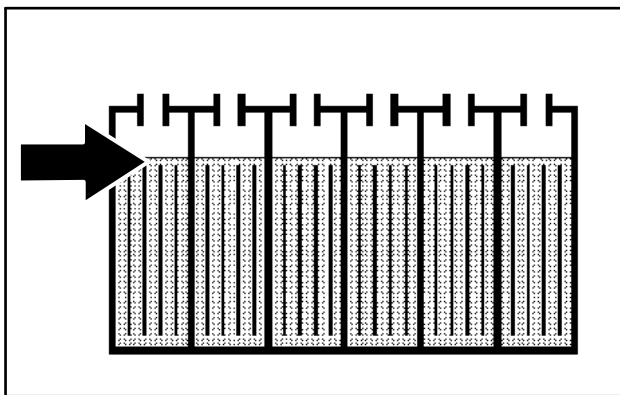

After every 200 hours of use check for loose battery connections and clean the surface of the batteries, including terminals and cable clamps, with a strong solution of baking soda and water. Brush the solution sparingly over the battery tops. Do not allow any baking soda solution to enter the batteries. Use a wire brush to clean the terminal posts and the cable connectors. Wipe off all cleaning solution residue. After cleaning, apply a coating of clear battery post protectant to the terminals and the cable connectors. Keep the tops of the batteries clean and dry.

Objects made of metal can potentially short circuit the batteries. Keep all metallic objects off the batteries. Replace any worn or damaged wires.

Measuring the specific gravity, using a hydrometer, is a way to determine the charge level and condition of the batteries. If one or more of the battery cells test lower than the other battery cells (0.050 or more), the cell is damaged, shorted, or is about to fail.

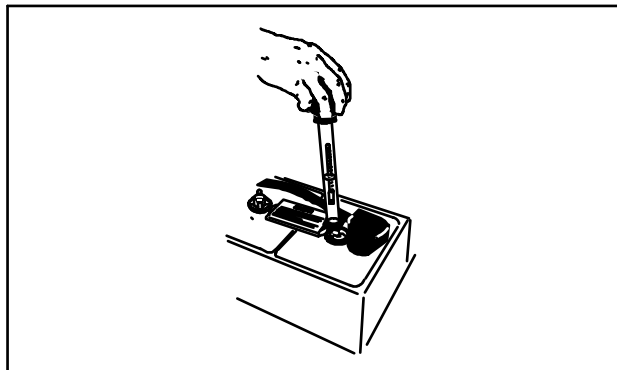

04380

NOTE: Do not take readings immediately after adding distilled water. If the water and acid are not thoroughly mixed, the readings may not be accurate. Check the hydrometer readings against the following chart to determine the remaining battery charge level:

| SPECIFIC GRAVITY at 27° C (80° F) | BATTERY CHARGE |
|--------------------------------------|-------------------|
| 1.277 | 100% Charged |
| 1.238 | 75% Charged |
| 1.195 | 50% Charged |
| 1.148 | 25% Charged |
| 1.100 | Discharged |

NOTE: If the readings are taken when the battery electrolyte is any temperature other than shown, the reading must be temperature corrected. Add or subtract to the specific gravity reading 0.004, 4 points, for each 6° C (10° F) above or below 25° C (77° F).

MAINTENANCE

CHARGING THE BATTERIES (OFF-BOARD CHARGER)

1. Drive the machine to a flat, dry surface in a well-ventilated area.
2. Stop the machine and turn the machine power off.

FOR SAFETY: Before leaving or servicing machine, stop on level surface and turn off machine.

3. Lift the operator seat open and engage the seat support bar.
4. Check the electrolyte level in all the battery cells.

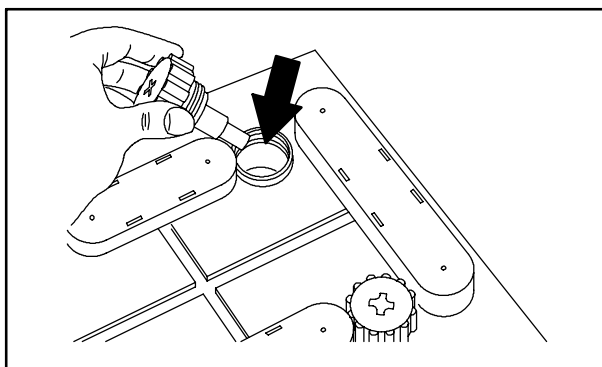

08247

5. If the level is low, add just enough distilled water to cover the battery plates. **DO NOT OVERFILL.** The batteries can overflow during charging due to expansion.

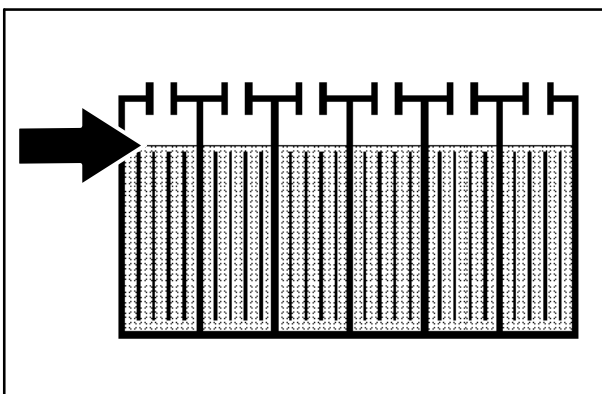

NOTE: Make sure the battery caps are in place while charging.

FOR SAFETY: When maintaining or servicing machine, avoid contact with battery acid.

6. Plug the battery charger into the remote battery charge connector.



WARNING: Batteries emit hydrogen gas. Explosion or fire can result. Keep sparks and open flame away. Keep covers open when charging.

NOTE: If the red "FAULT CODE" light flashes when the batteries are plugged into the charger, see "Battery Charger, Faults" in the TROUBLESHOOTING section of this manual.

7. The Tennant charger will start automatically. When the batteries are fully charged, the Tennant charger will automatically turn off.

NOTE: Set the charger to the proper rating for the batteries to prevent damage to the batteries or reduce the battery life.

8. After the charger has turned off, unplug the charger from the remote battery charge connector.
9. Check the electrolyte level in each battery cell after charging. If needed, add distilled water to raise the electrolyte level to about 12mm (0.4 in) below the bottom of the sight tubes.

FOR SAFETY: When maintaining or servicing machine, avoid contact with battery acid.

10. Close the operator seat.

CHARGING THE BATTERIES (ON-BOARD CHARGER)

1. Drive the machine to a flat, dry surface in a well-ventilated area.
2. Stop the machine and turn the machine power off.

FOR SAFETY: Before leaving or servicing machine, stop on level surface and turn off machine.

3. Lift the operator seat open and engage the seat support bar.
4. Check the electrolyte level in all the battery cells.

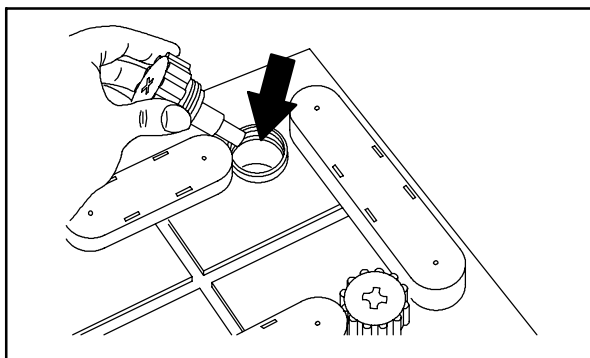

08247

5. If the level is low, add just enough distilled water to cover the battery plates. **DO NOT OVERFILL.** The batteries can overflow during charging due to expansion.

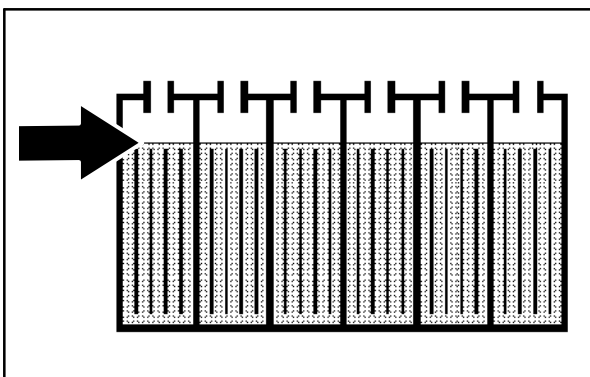

NOTE: Make sure the battery caps are in place while charging.

FOR SAFETY: When maintaining or servicing machine, avoid contact with battery acid.

6. Plug the on-board battery charger into a wall outlet. The Tennant on-board charger will start charging the batteries



WARNING: Batteries emit hydrogen gas. Explosion or fire can result. Keep sparks and open flame away. Keep covers open when charging.

7. The green LED will go on when charging is complete.



8. Unplug the on-board battery charger from the wall outlet.
9. Neatly stow the on-board battery charger cord inside the battery compartment.
10. Check the electrolyte level in each battery cell after charging. If needed, add distilled water to raise the electrolyte level to about 12mm (0.4 in) below the bottom of the sight tubes.
11. Close the operator seat.

MAINTENANCE

CIRCUIT BREAKERS

Circuit breakers are resettable electrical circuit protection devices designed to stop the flow of current in the event of a circuit overload. Once a circuit breaker is tripped, reset it manually by pressing the reset button after the breaker has cooled down.

Circuit breakers 1 through 10 are located in the front of the battery compartment.

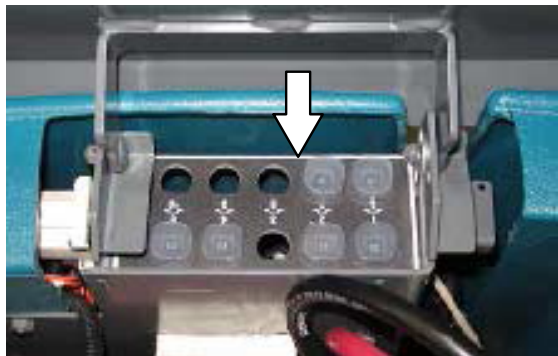

Circuit breakers 11 through 19 are located on the electrical panel.

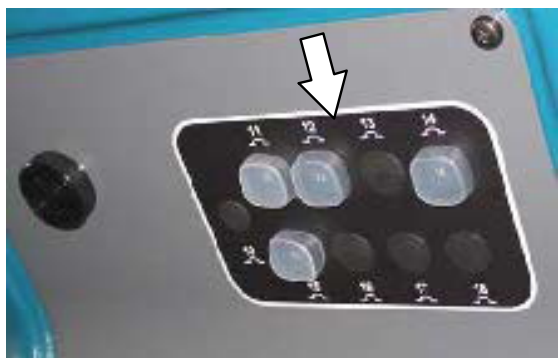

Circuit breaker 20 is located inside the optional light assembly mounted on top of the recovery tank.



If the overload that caused the circuit breaker to trip is still present, the circuit breaker will continue to stop current flow until the problem is corrected.

The chart below shows the circuit breakers and the electrical components they protect.

| Circuit Breaker | Rating | Circuit Protected |
|-----------------|--------|---------------------------------------|
| CB1 | 2.5 A | Start |
| CB2 | 2.5 A | Key switch |
| CB3 | 2.5 A | Sweep controls (Option) |
| CB4 | 2.5 A | Main water, FaST, ES, Horn |
| CB5 | 2.5 A | Detergent meter (Option) |
| CB6 | 2.5 A | Side brush (Option) |
| CB7 | 15 A | FaST ./ ES pump (Option) |
| CB8 | 20 A | Sweep brushes (Option) |
| CB9 | 2.5 A | ec-H2O (Option) |
| CB10 | 2.5 A | ec-H2O pump (Option) |
| CB11 | 15 A | Lights (Option) |
| CB12 | 2.5 A | Headlight / Tail lights (Option) |
| CB13 | 2.5 A | Overhead guard warning light (Option) |
| CB14 | 15 A | Vacuum wand (Option) |
| CB15 | 2.5 A | Warning lights (Option) |
| CB16 | 15 A | Pre-Sweep (Option) |
| CB17 | Open | Extra for Specials |
| CB18 | Open | Extra for Specials |
| CB19 | 25 A | Sweep vacuum fans (Option) |
| CB20 | 25 A | Reverse alarm light (Option) |

ELECTRIC MOTORS

Inspect the carbon brushes on the vacuum fan motor after every 500 hours of operation. Inspect the carbon brushes on the main brush motor, Pre-Sweep main brush motor, and side brush motors after the first 1000 hours of operation and every 100 hours after the initial check.

SCRUB BRUSHES

The machine can be equipped with either disk or cylindrical scrub brushes. Check scrub brushes daily for wire or string tangled around the brush or brush drive hub. Also check brushes or pads for damage and wear.

DISK BRUSHES AND PADS

Replace the brushes or pads when they no longer clean effectively.

Cleaning pads must be placed on pad drivers before they are ready to use. The cleaning pad is held in place with a center disk. Both sides of the pad can be used for scrubbing. Turn the pad over to use the other side.

Cleaning pads need to be cleaned immediately after use with soap and water. Do not wash the pads with a pressure washer. Hang pads, or lay pads flat to dry.

NOTE: Always replace brushes and pads in sets. Otherwise one brush or pad will be more aggressive than the other.

REPLACING DISK BRUSHES OR PAD DRIVERS

1. Raise the scrub head.
2. Turn off the machine.

FOR SAFETY: Before leaving or servicing machine, stop on level surface and turn off machine.

3. Open the left side squeegee support door.



4. Turn the brushes until the spring handles are visible.



5. Squeeze the spring handles and let the brushes drop to the floor.
6. Push the new brush under the scrub head, align the brush drive socket with the brush drive hub, and lift the brush up onto the brush drive hub.
7. Ensure the brush is securely mounted on the brush drive hub.
8. Close and secure the left side squeegee assembly.
9. Repeat procedure for the other brush.

MAINTENANCE

REPLACING DISK SCRUB PADS

1. Remove the pad driver from the machine.
2. Squeeze the spring clip together and remove the center disk from the pad driver.



3. Remove the scrub pad from the pad driver.



4. Flip or replace the scrub pad. Center the scrub pad on the pad driver and reinstall the center disk to secure the pad in place on the pad driver.
5. Reinstall the pad driver onto the machine.

CYLINDRICAL BRUSHES

Rotate the brushes from front-to-rear after every 50 hours of operation.

Replace the brushes when they no longer clean effectively.

NOTE: Replace worn brushes in pairs. Scrubbing with brushes of unequal bristle length will result in diminished scrubbing performance.

REPLACING CYLINDRICAL SCRUB BRUSHES

FOR SAFETY: Before leaving or servicing machine, stop on level surface and turn off machine.

1. Open the side squeegee support door.
2. Lift the idler plate retainer handle and unhook the retainer ring from the idler plate hook.



3. Remove the idler plate from the scrub head.



4. Remove the brush from the scrub head



5. Position the brush with the double row end towards the scrub head opening. Guide the new brush onto the drive hub.
6. If rotating the existing brushes, only rotate front to rear. Do NOT rotate end-for-end.

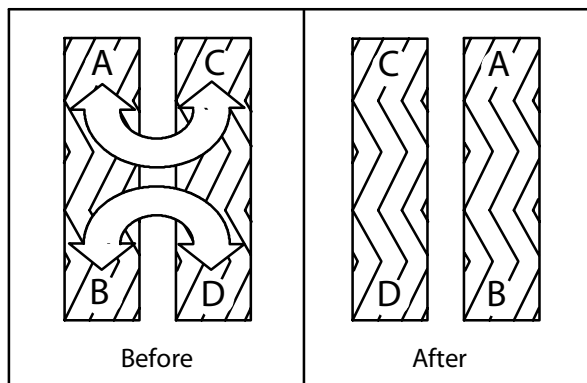

7. Reinstall the idler plate onto the scrub head and secure the idler plate into place with the idler plate retainer.
8. Repeat for the other brush on the other side of the scrub head.

NOTE: Each side of the scrub head is stamped with a letter. The idler door is stamped with the same letter. Make sure the letter on the idler door matches the letter on the scrub head when reinstalling the doors.

MAINTENANCE

CHECKING CYLINDRICAL SCRUB BRUSH PATTERN

FOR SAFETY: Before leaving or servicing machine, stop on level surface and turn off machine.

1. Apply chalk, or a similar marking material, to a smooth and level section of floor.

NOTE: If chalk or other material is not available, allow the brush to spin on the floor for two minutes. A polish mark will remain on the floor.

2. Park the machine several feet behind the chalked area and shut off the machine.
3. Press and hold the *configuration mode button* while turning the key to the on position. Continue holding the *configuration mode button* until CONFIG MODE appears on the LCD display. Release the *configuration mode button*.



4. Press the *Brush pressure button* to enter the machine configuration modes.



C1: Disk/Cyl Cyl should appear in the LCD display.



5. Press the *Contrast control button* once to scroll to **C16: Dwn Pres Tst Disabled** (Down Pressure Test Disabled).

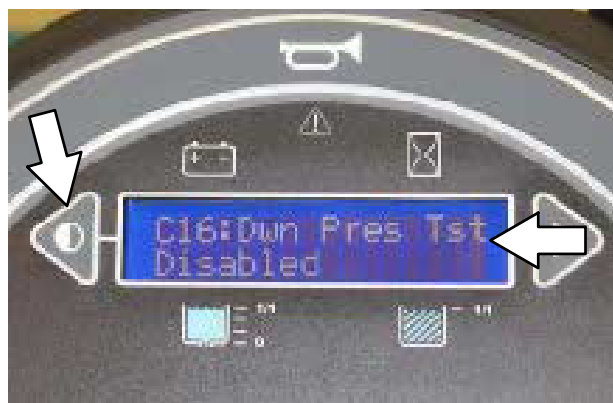

6. Press the *Brush pressure* button to enter the down pressure test selection mode.

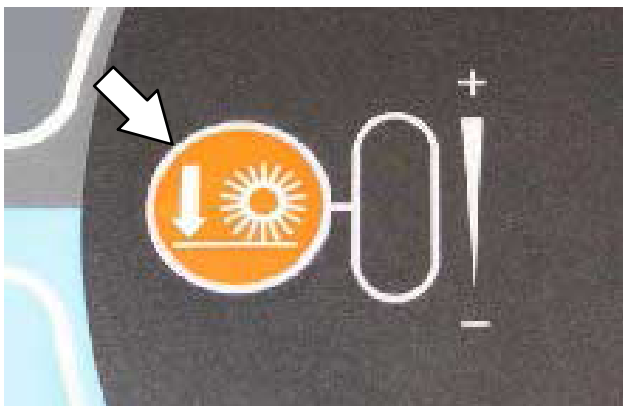

C16: Dwn Pres Tst <Disabled (Down Pressure Test Disabled) should appear on the LCD display. The < symbol must appear in front of **Disabled**.



7. Press the *Contrast control* button once to select **C16:Dwn Pres Tst <Enabled** (Down Pressure Test Enabled). The < symbol must appear in front of **Enabled**.



8. Press the *Brush pressure* button to enable the brush pressure test.

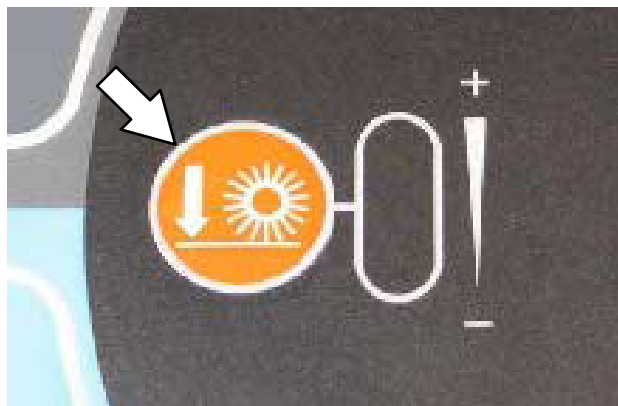

C16: Dwn Pres Tst Enabled should appear on the LCD display. The < symbol should no longer appear in front of **Enabled**.



9. Turn the key to the off position to save the Down Pressure Test Enabled mode and then turn the key back to the on position to continue with the procedure.

Note: Do Not turn off the machine second time after the Down Pressure Test Enabled mode has been saved. The entire procedure to get the machine into the Down Pressure Test Mode will need to be repeated if the machine is turned off a second time.

MAINTENANCE

10. Press the *1-STEP* button and then immediately press one of the *Solution on/off* buttons to shut off the solution supply and prevent the brushes from getting wet.

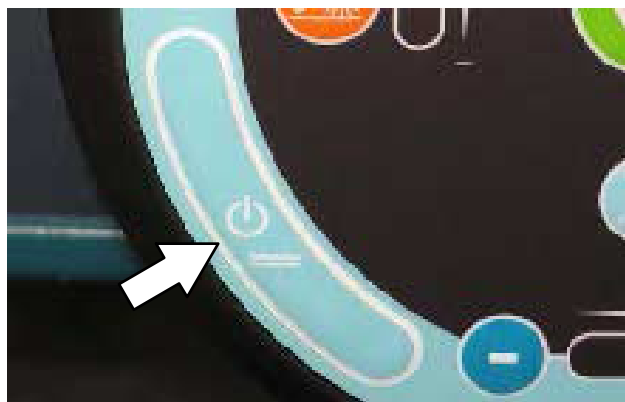
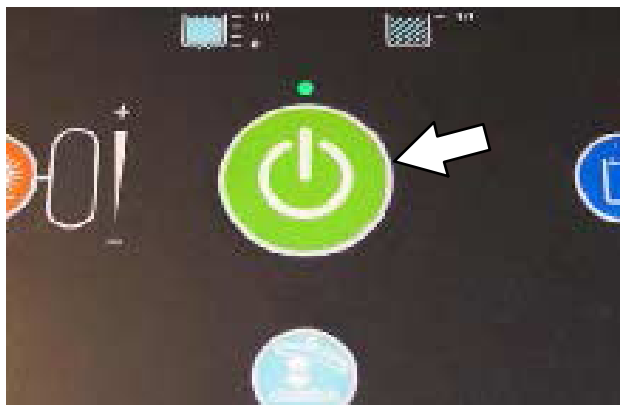

11. Observe the solution flow indicator lights. None of the indicator lights should be illuminated.

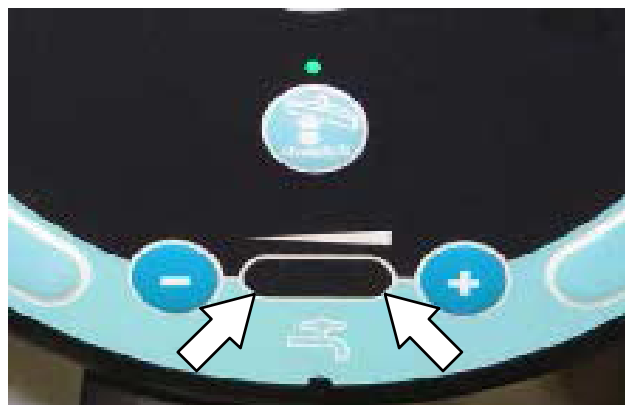

12. Press the *1-STEP* button to raise the scrub head.

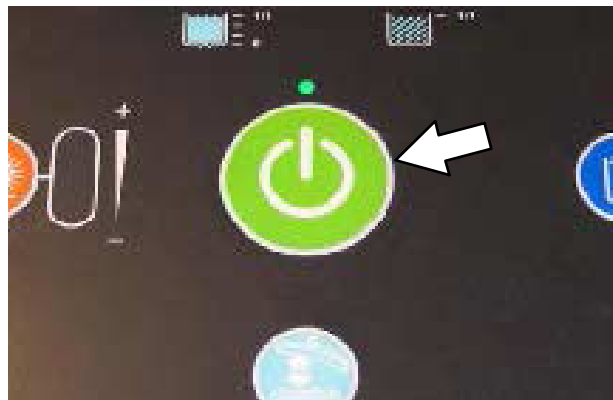

13. Position the machine over the chalked area.

14. Press the *1-STEP* button to lower the scrub head and allow the brushes to operate for 15 to 20 seconds. Keep the scrub head in one spot in the chalked area.

NOTE: If necessary, press the Brush pressure button to set the brush pressure to the medium setting.



15. Press the *1-STEP* button to raise the scrub head and drive the machine away from the chalked area.

16. Observe the brush patterns. If the brush pattern is the same width across the entire length of each brush and both brushes are the same width, no adjustment is necessary.

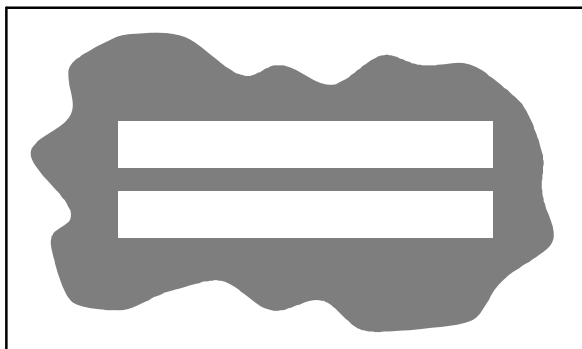

10355

17. If the brush patterns are tapered, see *ADJUSTING THE CYLINDRICAL BRUSH TAPER* section of this manual.

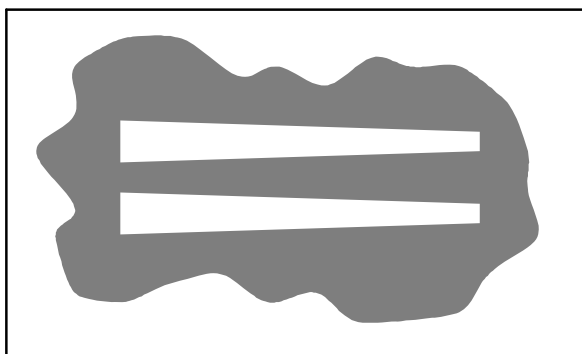

10652

18. The brush patterns should be 25 to 38 mm (1 to 1.5 in) wide with the brushes in the lowered position and both patterns should be the same width. If the width of the brushes is not the same, see *ADJUSTING THE CYLINDRICAL BRUSH WIDTH* section of this manual.

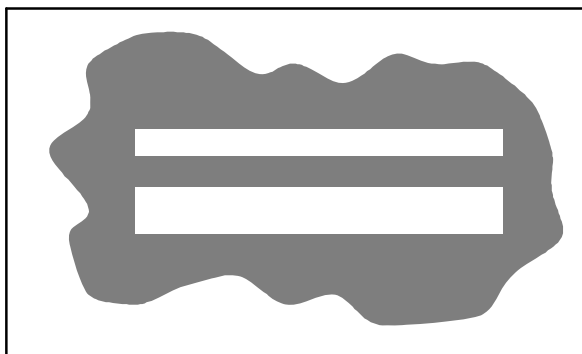

10653

19. Turn the key to the off position to return to normal operation.

ADJUSTING CYLINDRICAL BRUSH TAPER

FOR SAFETY: Before leaving or servicing machine, stop on level surface and turn off machine.

1. Open the side squeegee support door.
2. Loosen the mounting screw on the idler door.



3. Raise or lower the end of the brush with the smaller brush adjustment screw as necessary to straighten the brush pattern.

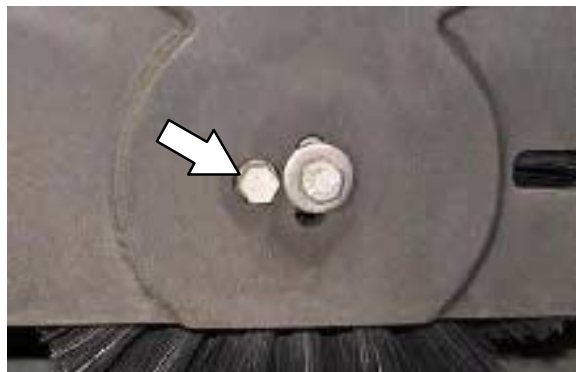

4. Retighten the mounting screw on the idler door.
5. Close the side squeegee support door.
6. Recheck the pattern. Readjust if necessary.
7. Repeat procedure for the other brush located on other side of the scrub head.

MAINTENANCE

ADJUSTING CYLINDRICAL BRUSH PATTERN WIDTH

FOR SAFETY: Before leaving or servicing machine, stop on level surface and turn off machine.

1. Start the machine, completely lower the scrub head, and turn off the machine.
2. Open the side squeegee support door.
3. Remove the debris trough
4. Loosen the lock nut located behind the bracket.



5. Turn the adjustment nut to adjust the cylindrical brush pattern width. Lengthen the scrub head link to increase the rear brush pattern width. Shorten the scrub head link to increase the front brush pattern.

NOTE: Two full turns of the scrub head link adjustment bolt will change the brush pattern approximately 25 mm (1 in).



6. Retighten the lock nut located against the bracket.
7. Recheck the pattern. Readjust if necessary.

SIDE BRUSH (OPTION)

Check the side brush daily for wear or damage. Remove any tangled string or wire from the side brush or side brush drive hub.

REPLACING THE SIDE BRUSH

Replace the brush when it no longer cleans effectively.

1. Start the machine and press the side brush switch.
2. Shut off the machine after the side brush rotates from under the side guard, but before the side brush assembly lowers to the floor.



FOR SAFETY: Before leaving or servicing machine, stop on level surface and turn off machine.

3. Remove the knobs holding the side brush squeegee assembly to the machine and remove the squeegee assembly from the machine.



4. Squeeze the spring handles and let the side brush drop to the floor.

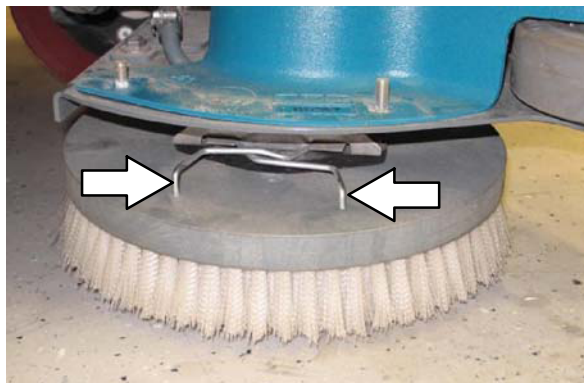

5. Remove the side brush from under the side brush assembly.
6. Place the new side brush underneath the side brush assembly and lift the side brush up onto the side brush hub until the brush locks onto the hub.
7. Reinstall the side brush squeegee assembly onto the side brush assembly.

MAINTENANCE

PRE-SWEEP BRUSHES

The Pre-Sweep assembly is equipped with disk side brushes and a cylindrical main brush. Check the brushes daily for wire or string tangled around the brush or brush drive hub. Check the brushes daily for damage and wear.

REPLACING THE PRE-SWEEP DISK BRUSHES

Replace the brushes when they no longer clean effectively.

1. Turn on the machine.
2. Press the bottom of the Pre-Sweep switch to raise the Pre-Sweep assembly and stop sweeping.



3. Turn off the machine.

FOR SAFETY: Before leaving or servicing machine, stop on level surface and turn off machine.

4. Reach into the center of the brush and pull the cotter pin from the hub assembly.



5. Remove the side brush from under the Pre-Sweep assembly.
6. Install the new side brush onto the Pre-Sweep side brush assembly.

REPLACING THE PRE-SWEEP CYLINDRICAL BRUSH

Replace the brush when it no longer cleans effectively.

FOR SAFETY: Before leaving or servicing machine, stop on level surface and turn off machine.

1. Turn off the machine.
2. Open the Pre-Sweep assembly cover and lock the cover open.
3. Loosen and remove the left brush arm knob.



4. Remove the left brush arm.



5. Remove the three knobs holding the Pre-Sweep side skirt and side skirt plate to the Pre-Sweep assembly.



6. Remove the side skirt plate and side skirt from the Pre-Sweep assembly.



7. Remove the cylindrical brush and replace with a new brush.



8. Guide the slotted end of the new brush onto the drive hub.
9. Reinstall the side skirt, side skirt plate, and left brush arm.

MAINTENANCE

CHECKING AND ADJUSTING PRE-SWEEP CYLINDRICAL BRUSH PATTERN

FOR SAFETY: Before leaving or servicing machine, stop on level surface and turn off machine.

1. Apply chalk, or a similar marking material, to a smooth and level section of the floor.

NOTE: If chalk or other material is not available, allow the brush to spin on the floor for two minutes. A polish mark will remain on the floor.

2. Park the machine several feet behind the chalked area and shut off the machine.
3. Press and hold the *configuration mode button* while turning the key to the on position. Continue holding the *Configuration mode button* until CONFIG MODE appears on the LCD display. Release the *configuration mode button*.



4. Press the *Brush pressure button* to enter the machine configuration modes.



C1: Disk/Cyl Cyl should appear in the LCD display.



5. Press the *Contrast control button* once to scroll to **C16: Dwn Pres Tst Disabled** (Down Pressure Test Disabled).



C16: Dwn Pres Tst <Disabled (Down Pressure Test Disabled) should appear on the LCD display. The < symbol must appear in front of **Disabled** .



6. Press the *Brush pressure button* to enter the down pressure test selection mode.



7. Press the *Contrast control button* once to select **C16: Dwn Pres Tst <Enabled** (Down Pressure Test Enabled). The < symbol must appear in front of **Enabled**.



MAINTENANCE

8. Press the the *Brush pressure* button to enable the brush pressure test.



C16: Dwn Pres Tst Enabled should appear on the LCD display. The < symbol should no longer appear in front of **Enabled**.



9. Turn the key to the off position to save the Down Pressure Test Enabled mode and then turn the key back to the on position to continue with the procedure.

NOTE: Do Not turn off the machine a second time after the Down Pressure Test Enabled mode has been saved. The entire procedure to get the machine into the Down Pressure Test Mode will need to be repeated if the machine is turned off a second time.

10. Press the *1-STEP* button and then immediately press one of the *Solution on/off* buttons to shut off the solution supply.

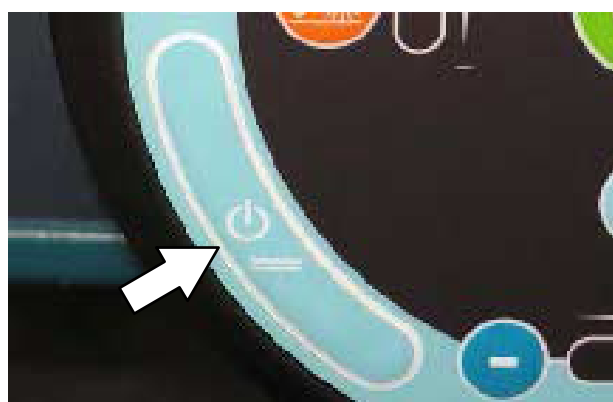
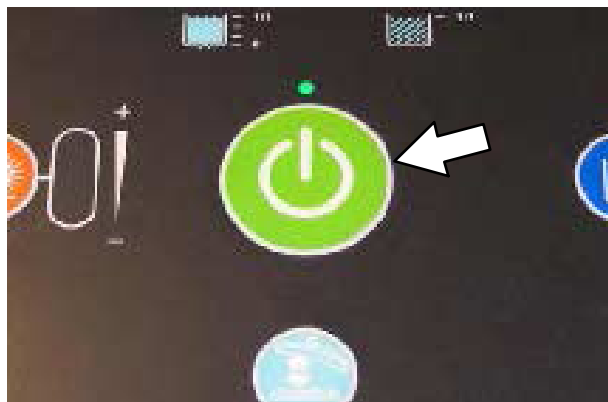

11. Observe the solution flow indicator lights. None of the indicator lights should be illuminated.



12. Center the Pre-Sweep assembly over the chalked area on the floor.
13. Press the *Pre-Sweep switch* to the middle position. The Pre-Sweep assembly will lower and the brush will begin spinning.
14. Press the bottom of the *Pre-Sweep switch* to shut off the Pre-sweep system. The Pre-Sweep brush will stop spinning and the Pre-Sweep assembly will raise to the off position.
15. Drive the machine away from the chalked area.
16. Observe the shape of the brush pattern. If the brush pattern has parallel sides, the brush does not need adjustment.

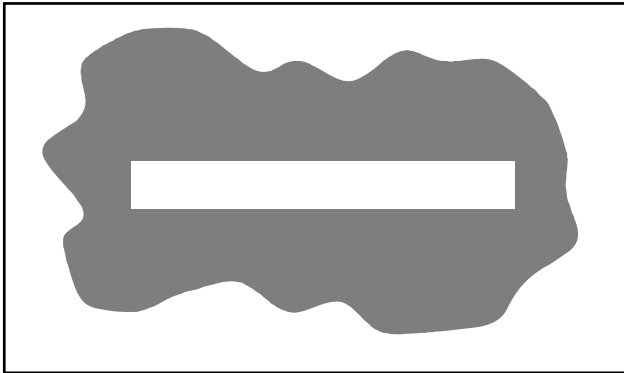

10355

17. If the brush pattern is tapered, the brush needs adjustment to straighten the brush pattern.

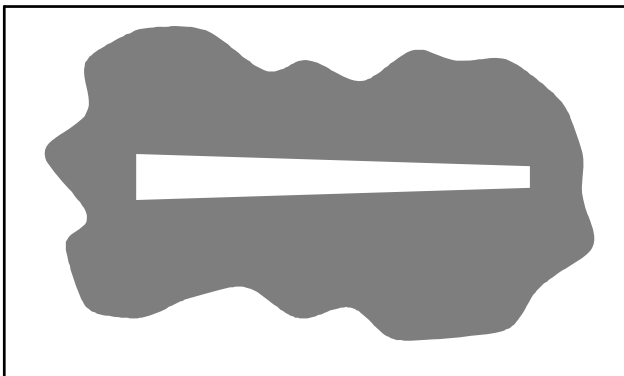

10356

18. To adjust the brush taper, loosen the nut on the arm adjustment plate.

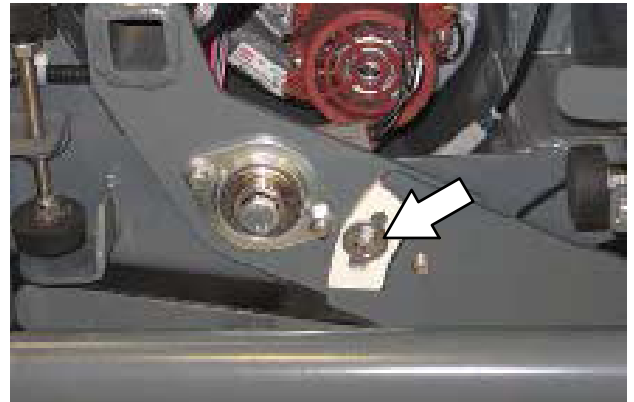

19. Press the *Pre-Sweep switch* to the middle position. Allow the brush to float in place for 15 to 20 seconds.
20. Tighten the nut on the arm adjustment plate.
21. Check the brush pattern again and readjust as necessary until the width of the pattern is the same along the length of the brush pattern.

MAINTENANCE

FaST SYSTEM

REPLACING THE FaST-PAK CARTON

FOR SAFETY: Before leaving or servicing machine, stop on level surface and turn off machine.

1. Lift the operator seat open and engage the seat support bar.
2. Squeeze the button on the FaST supply hose connector, then pull the empty FaST-PAK carton out from the compartment and discard.



3. Remove the perforated knock outs from the new FaST-PAK carton. DO NOT remove the bag from the carton. Pull the hose connector from the bottom of the bag and remove the hose cap from the connector.

NOTE: The FaST-PAK Floor Cleaning Concentrate is specially designed for use with the FaST system scrubbing application. NEVER use a substitute. Other cleaning solutions may cause FaST system failure.

4. Slide the FaST-PAK carton into the FaST-PAK bracket.

5. Connect the FaST supply hose to the FaST-PAK hose connector.
6. Scrub with the FaST system for a few minutes to allow the detergent to reach maximum foaming.

CLEANING THE FaST SUPPLY HOSE CONNECTOR

Soak the connector in warm water if detergent buildup is visible. When a FaST-PAK carton is not installed, store the supply hose connector on the storing plug to prevent the hose from clogging.

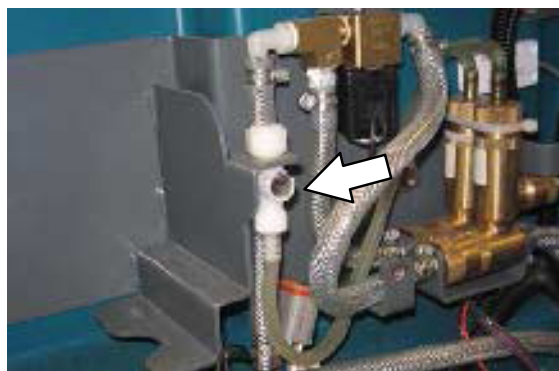

REPLACING THE FaST INJECTOR FILTERS

Replace the FaST injector filters after every 1000 hours of operation. Empty the solution tank before replacing the filters.

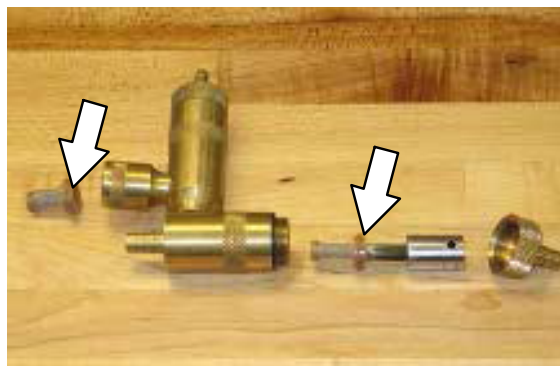
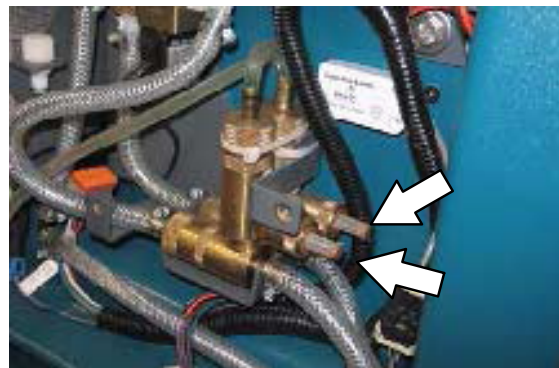

ec-H2O MODULE FLUSH PROCEDURE

This procedure is only required when an alarm sounds and the *ec-H2O* system indicator light begins to blink.

FOR SAFETY: Before leaving or servicing machine, stop on level surface and turn off machine.

1. Lift the operator seat open and engage the seat support bar.
2. Remove the *ec-H2O* compartment cover.

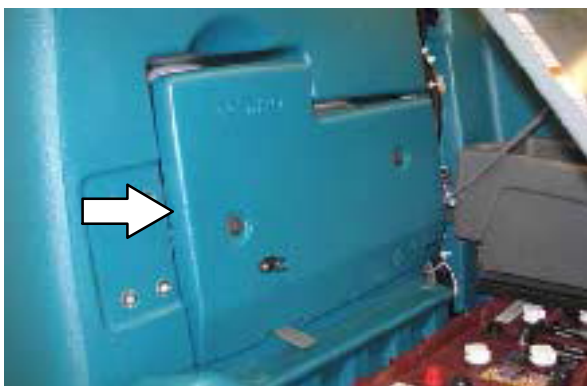

3. Remove the drain hose from the *ec-H2O* compartment.



4. Disconnect the outlet hose from the hose connected to the *ec-H2O* manifold.



5. Connect the drain hose to the *ec-H2O* manifold hose disconnected from the outlet hose in the previous step.



6. Place the drain hose into a empty container.
7. Pour 2 gallons (7.6 liters) of white or rice vinegar into the solution tank.

FOR SAFETY: Wear protective gloves and eye protection when handling vinegar.



MAINTENANCE

8. Turn the key to the on (I) position.

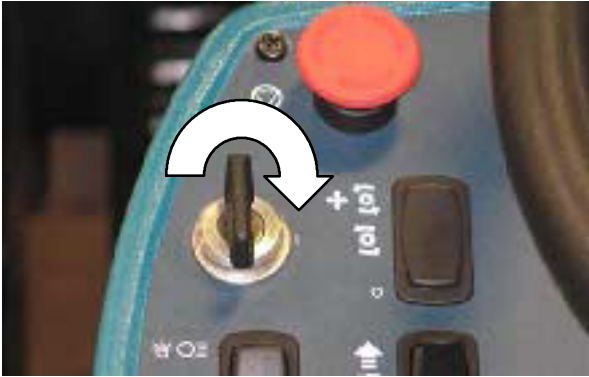

9. Press and release the ec-H₂O module flush switch to start the flush cycle.

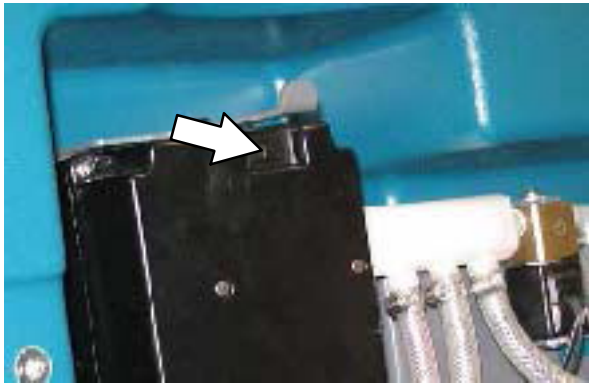

NOTE: The module will automatically shut off when the flush cycle is complete (approximately 7 minutes). The module must run the full 7 minute cycle in order to reset the system indicator light and alarm.

10. Pour 2 gallons (7.6 liters) of cool clean water into the solution tank.
11. Press and release the flush switch to rinse any remaining vinegar from the module. After 1-2 minutes, press the flush switch to turn off the module.
12. Disconnect the drain hose from the ec-H₂O manifold hose.
13. Reconnect the outlet hose to the the scrub head to the ec-H₂O manifold hose.
14. Place the drain hose back into the ec-H₂O compartment.
15. Reinstall the ec-H₂O compartment cover.
16. Close the operator seat cover.

SQUEEGEE BLADES

Check the squeegee blades for damage and wear daily. When the blades become worn, rotate the blades end-for-end or top-to-bottom to a new wiping edge. Replace blades when all edges are worn.

Check the deflection of the squeegee blades daily or when scrubbing a different type of surface. Check the leveling of the rear squeegee every 50 hours of operation.

REPLACING (OR ROTATING) THE REAR SQUEEGEE BLADES

1. Lower the scrub head.

FOR SAFETY: Before leaving or servicing machine, stop on level surface and turn off machine.

2. Disconnect the vacuum hose from the rear squeegee assembly.

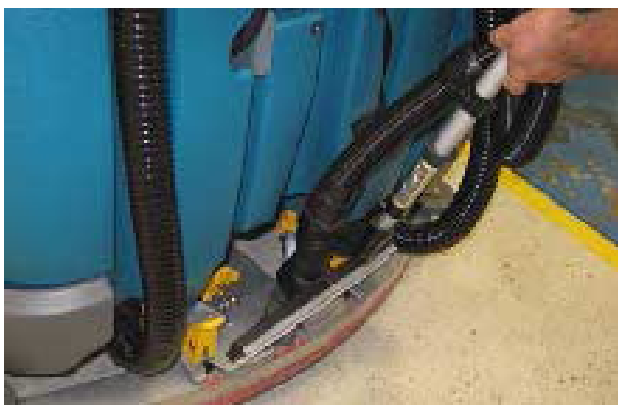

3. Loosen both squeegee mounting handles.

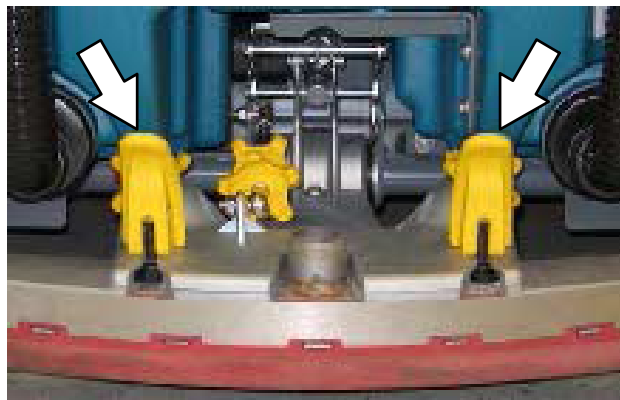

4. Pull the rear squeegee assembly from the machine.

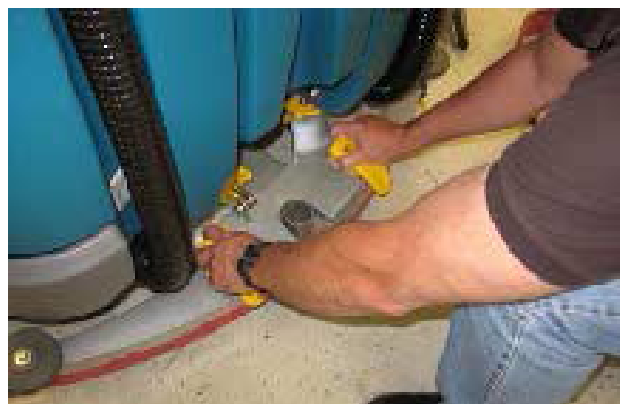

MAINTENANCE

5. Loosen the rear squeegee retainer latch and remove the retainer from the squeegee assembly.



6. Remove the squeegee from the squeegee assembly.



7. Slide both retainers out away from the squeegee assembly.

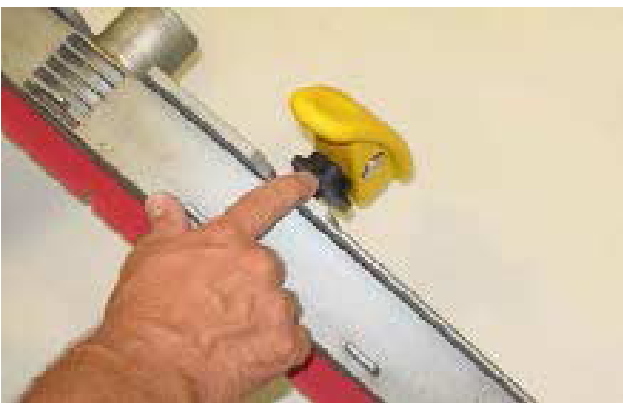

8. Remove the inner frame from the outer frame.

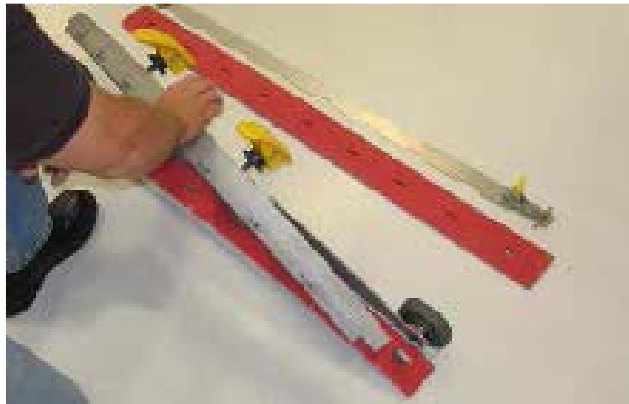

9. Remove the squeegee from the outer frame.

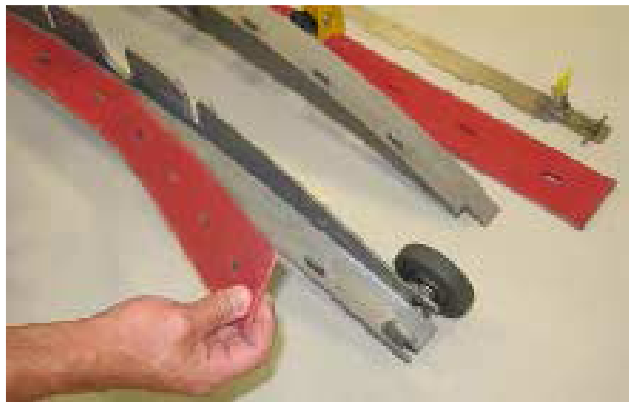

10. Install the rotated or new squeegee blade into the outer frame. Be sure the squeegee is completely slid down onto each tab on the outer frame.

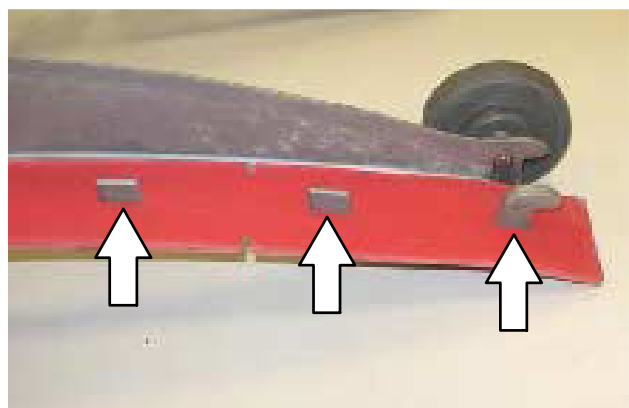

11. Install the inner frame over the squeegee and onto the outer frame. Be sure the inner frame is tight against the top of the outer frame.

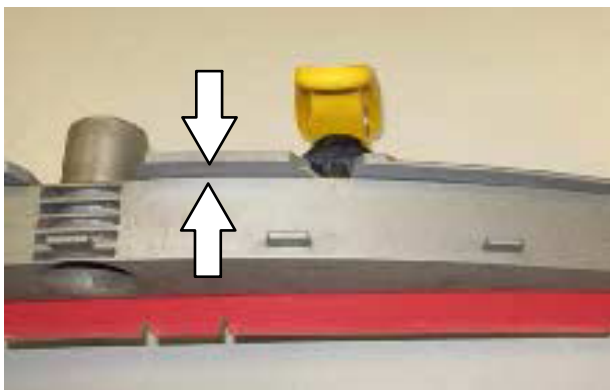

12. Slide both retainers into the squeegee assembly.



13. Place the rotated or new squeegee blade onto the inner frame. Be sure the squeegee is securely attached on each tab on the inner frame.



14. Insert the hinge end of the retainer into the hooks in the inner frame.

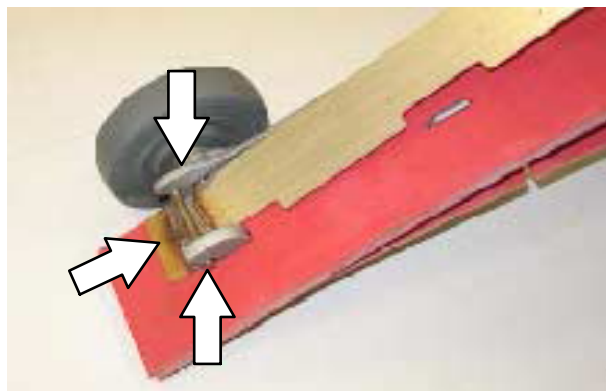

15. Install the retainer along the rest of the squeegee assembly and fasten the latch onto the other end of the squeegee assembly.

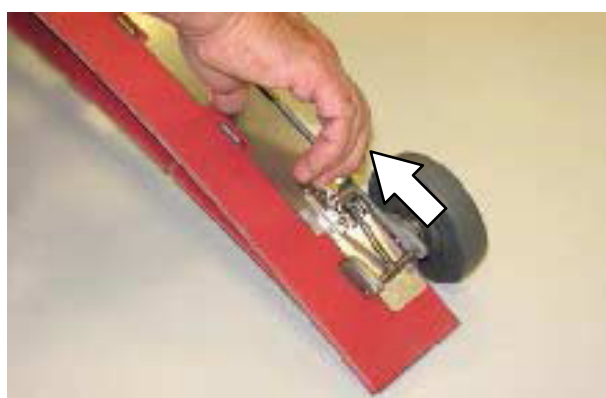
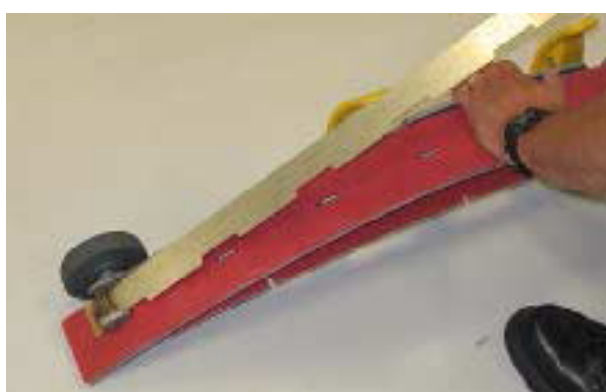

MAINTENANCE

LEVELING THE REAR SQUEEGEE

Leveling the squeegee ensures the entire length of the squeegee blade is in even contact with the surface being scrubbed. Perform this adjustment on an even and level floor.

1. Lower the squeegee and drive the machine several meters (feet) forward and slowly bring the machine to a stop.

FOR SAFETY: Before leaving or servicing machine, stop on level surface and turn off machine.

2. Check the squeegee deflection over the full length of the squeegee blade.
3. If the deflection is not the same over the full length of the blade, use the tilt adjust knob to make adjustments.

DO NOT disconnect the vacuum hose from the squeegee frame when leveling squeegee.

4. To adjust the squeegee leveling, loosen the tilt lock knob.

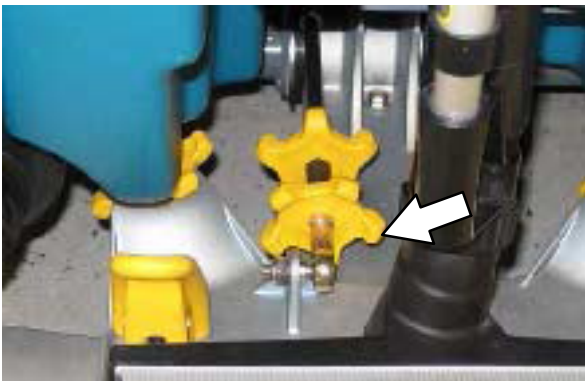

5. Turn the squeegee tilt adjust knob counter-clockwise to decrease the deflection at the ends of the squeegee blade.

Turn the squeegee tilt adjust knob clockwise to increase the deflection at the ends of the squeegee blade.

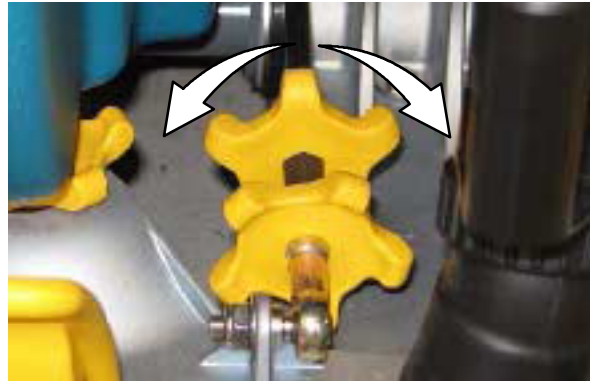

6. Tighten the tilt lock knob.
7. Drive the machine forward with the squeegee down to recheck the squeegee blade deflection if adjustments were made.
8. Readjust the squeegee blade deflection if necessary.

ADJUSTING THE REAR SQUEEGEE BLADE DEFLECTION

Deflection is the amount of curl the overall squeegee blade has when the machine moves forward. The best deflection is when the squeegee wipes the floor dry with a minimal amount of deflection.

NOTE: Make sure the squeegee is level before adjusting the deflection. See LEVELING THE REAR SQUEEGEE.

1. Lower the squeegee and drive the machine several meters (feet) forward and slowly bring the machine to a stop.

FOR SAFETY: Before leaving or servicing machine, stop on level surface and turn off machine.

2. Look at the amount of deflection or "curl" of the squeegee blade. The correct amount of deflection is 12 mm (0.50 in) for scrubbing smooth floors and 15 mm (0.62 in) for rough floors.

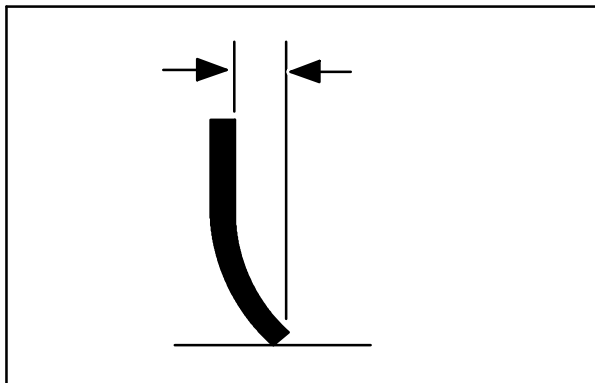

3. To adjust the overall squeegee blade deflection, loosen the lock knob.

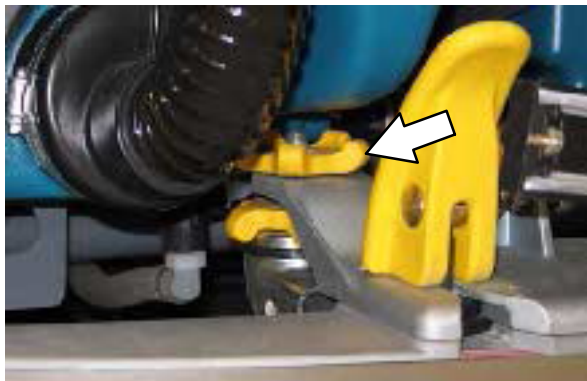

4. Turn the adjustment knobs counterclockwise to increase deflection or clockwise to decrease deflection.



5. Retighten the lock knob.
6. Drive the machine forward again to recheck the squeegee blade deflection.
7. Readjust the squeegee blade deflection if necessary.

MAINTENANCE

REPLACING OR ROTATING THE SIDE SQUEEGEE BLADES

1. If necessary, raise the scrub head.

FOR SAFETY: Before leaving or servicing machine, stop on level surface and turn off machine.

2. Open the side squeegee support door.
3. Unhook the retaining band latch from the side squeegee assembly.



4. Remove the retaining band from the side squeegee assembly.



5. Remove the squeegee from the side squeegee assembly.



6. Install the rotated or new rear squeegee blade onto the side squeegee assembly.

7. Hook the retaining band onto the side squeegee assembly.

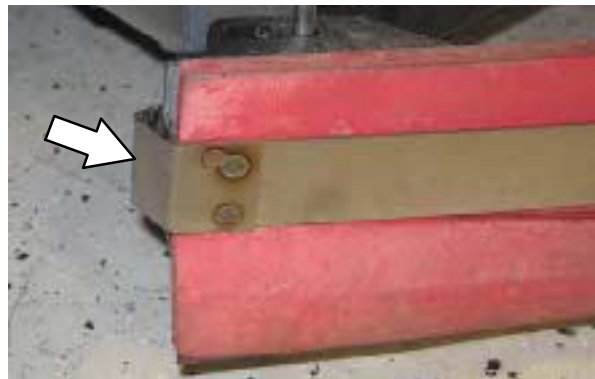

8. Fasten the retaining band latch onto the side squeegee assembly.

9. Repeat for the side squeegee on the other side of the scrub head.

REPLACING OR ROTATING THE SIDE BRUSH SQUEEGEE BLADE(S) (OPTION)

Check the side brush squeegee blade for damage and wear daily. Replace or rotate the blade if the leading edge is torn or worn half-way through the thickness of the blade.

1. Start the machine and press the side brush switch.
2. Shut off the machine after the side brush rotates from under the side guard, but before the side brush assembly lowers to the floor.



FOR SAFETY: Before leaving or servicing machine, stop on level surface and turn off machine.

3. Remove the knobs holding the side brush squeegee assembly to the machine and remove the squeegee assembly.



4. Loosen the retaining band latch.



MAINTENANCE

5. Remove the squeegee blade(s) and retainer from the squeegee frame.



NOTE: Observe which squeegee slots were installed on the squeegee frame before removing the squeegee.



NOTE: Brush wear may affect squeegee deflection. Install / reinstall squeegees so the deflection is approximately 12 mm (0.50 in) for smooth floors and 15 mm (0.62 in) for rough floors.

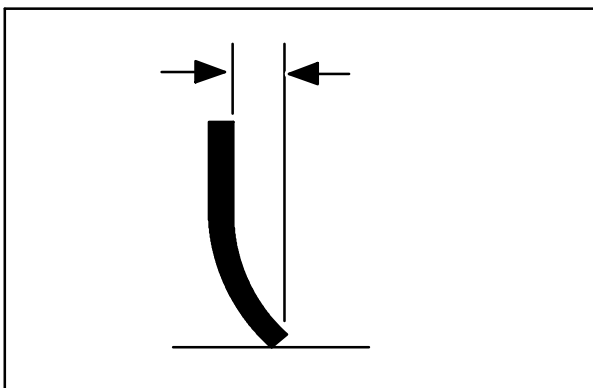

6. Install the rotated / new squeegee blade(s) and retainer onto the side brush assembly.



7. Fasten the side brush retaining band latch.

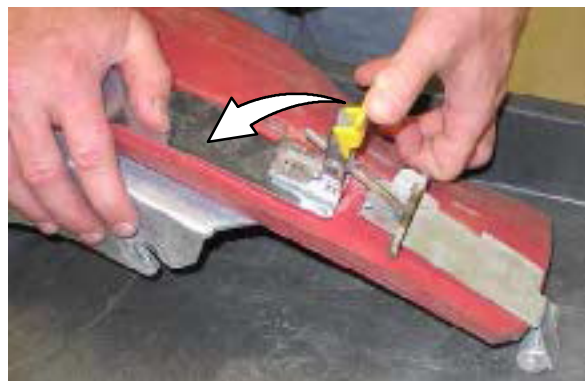

8. Reinstall the side brush squeegee assembly onto the side brush assembly.

SKIRTS AND SEALS

PRE-SWEEP SIDE SKIRTS (OPTION)

The side skirts are located on both sides of the Pre-Sweep assembly. The side skirts should be just touching the floor.



Check the skirts for damage and wear after every 50 hours of operation.

PRE-SWEEP RECIRCULATION SKIRT (OPTION)

The Pre-Sweep recirculation skirt is located behind the main sweeping brush.



Check the skirt for damage and wear after every 50 hours of operation.

PRE-SWEEP REAR SKIRT (OPTION)

The Pre-Sweep rear skirt is located behind the recirculation skirt and main sweeping brush.

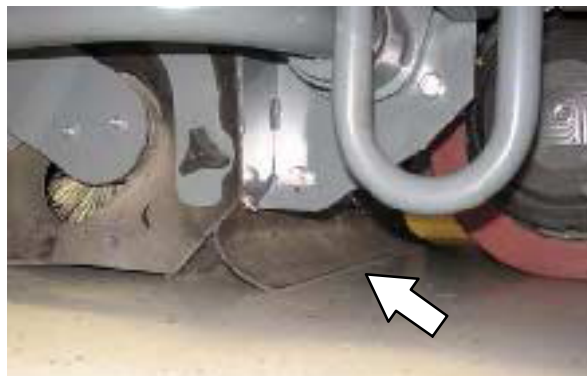

Check the skirt for damage and wear after every 50 hours of operation.

MAINTENANCE

BELTS AND CHAINS

STEERING CHAIN

The steering chain is located on the steering column directly under the control panel. There should be no slack in the chain. Check the steering chain tension after every 200 hours.



CYLINDRICAL BRUSH DRIVE BELTS

The brush drive belts are located on the cylindrical brush scrub head. Check the belts for damage and wear after every 200 hours of operation.



PRE-SWEEP BRUSH DRIVE BELT (OPTION)

The Pre-Sweep brush drive belt is located inside the Pre-Sweep assembly on the right side of the cylindrical brush. Check the belt for damage and wear after every 200 hours of operation.



TIRES

The machine has three solid rubber tires: one in front, and two in the rear of the machine. Check tires for damage and wear after every 500 hours of operation.



PUSHING, TOWING, AND TRANSPORTING THE MACHINE

PUSHING OR TOWING THE MACHINE

If the machine becomes disabled, it can be pushed or towed from the front or rear.

The parking brake must be disabled before towing or pushing the machine. To disable the brake, insert the tip of a small screw driver between the electronic brake lever and the hub. The machine can move freely when the parking brake is disabled.



Only push or tow the machine for a very short distance and do not exceed 3.2 kp/h (2 mph). It is NOT intended to be pushed or towed for a long distance or at a high speed.

ATTENTION! Do not push or tow machine for a long distance or damage may occur to the propelling system.

Immediately after pushing the machine, remove the screw driver from between the electronic brake lever and the hub. NEVER operate the machine with the parking brake disabled.

FOR SAFETY: Do not operate machine with brake disabled.

TRANSPORTING THE MACHINE

1. Position the machine at the loading edge of the truck or trailer.

FOR SAFETY: Use truck or trailer that will support the weight of the machine.

NOTE: Empty the recovery and solution tanks before transporting the machine.

2. If the loading surface is not horizontal or is higher than 380 mm (15 in) from the ground, use a winch to load machine.

If the loading surface is horizontal AND is 380 mm (15 in) or less from the ground, the machine may be driven onto the truck or trailer.

3. To winch the machine onto the truck or trailer, attach the winching chains to the stabilizer legs.



FOR SAFETY: When unloading machine off truck or trailer, use winch. Do not drive the machine off the truck or trailer unless the loading surface is horizontal AND 380 mm (15 in) or less from the ground.

4. Position the machine onto the truck or trailer as far as possible. If the machine starts to veer off the center line of the truck or trailer, stop and turn the steering wheel to center the machine.

MAINTENANCE

5. Lower the scrub head and block the machine tires. Tie down the machine to the truck or trailer before transporting.

The front tie-down locations are the stabilizer legs.



The rear tie-down locations are the holes in the frame.



6. If the loading surface is not horizontal or is higher than 380 mm (15 in) from the ground, use a winch to unload machine.

If the loading surface is horizontal AND is 380 mm (15 in) or less from the ground, the machine may be driven off the truck or trailer.

FOR SAFETY: When unloading machine off truck or trailer, use winch. Do not drive the machine off the truck or trailer unless the loading surface is horizontal AND 380 mm (15 in) or less from the ground.

MACHINE JACKING

FOR SAFETY: Before leaving or servicing machine, stop on level surface.

Empty the recovery and solution tanks before jacking the machine. Jack up the machine from underneath the jack point at the front of the machine and the two jack points located near the rear tires at the back of the machine. Use a hoist or jack that will support the weight of the machine.

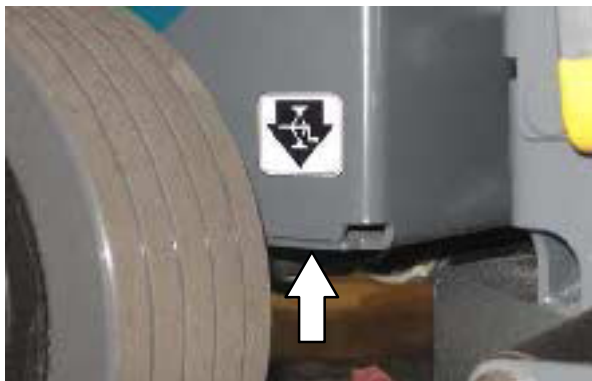

Always stop the machine on a flat level surface and block the tires before jacking the machine up.

FOR SAFETY: When servicing machine, block machine tires before jacking machine up. Use a hoist or jack that will support the weight of the machine. Jack machine up at designated locations only. Support machine with jack stands.

STORAGE INFORMATION

The following steps should be taken when storing the machine for extended periods of time.

1. Drain and clean the solution and recovery tanks.
2. Park the machine in a cool, dry area indoors. Do not expose the machine to rain.
3. Remove the batteries, or charge them every three months.

MAINTENANCE

FREEZE PROTECTION (MACHINES WITHOUT OPTIONAL ec-H2O SYSTEM)

FOR SAFETY: Before leaving or servicing machine, stop on level surface and turn off machine.

1. Machines equipped with FaST: Remove the FaST-PAK.
2. Completely drain the solution tank and recovery tank.
3. Disconnect the hose from the solenoid valve inlet port located on the bottom of the frame and allow all remaining solution to drain from the system.

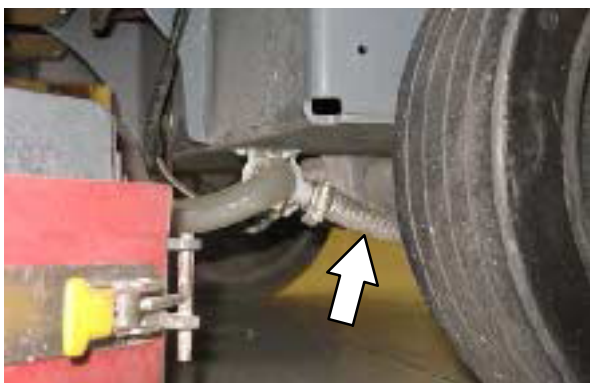

4. Use between 13.8 – 27.6 kPa (2 – 4 psi) of compressed air to blow remaining solution from the disconnected hose.

FOR SAFETY: Wear eye and ear protection when using pressurized air or water.

5. Reconnect the hose to the solenoid valve inlet port.
6. Pour 7.6 L (2 gal) of Propylene Glycol Based / Recreational Vehicle (RV) antifreeze into the solution tank.



7. Turn on the machine
8. Press the 1-STEP button.



9. Repeatedly press the Solution increase button (+) until the solution flow is at the highest setting.



10. Drive the machine to circulate the RV antifreeze completely through the system.
11. Press the 1-STEP button to turn off the system.
12. Machines equipped with the optional spray nozzle only: Operate the wand for a few seconds to protect the pump.
13. Turn off the machine.
14. The remaining RV antifreeze does not need to be drained from the solution tank.

PREPARING THE MACHINE FOR OPERATION (MACHINES WITHOUT OPTIONAL ec-H2O SYSTEM)

All Propylene Glycol Based / Recreational Vehicle (RV) Antifreeze must be completely cleaned from the scrubbing system before the machine can be used for scrubbing.

FOR SAFETY: Before leaving or servicing machine, stop on level surface and turn off machine.

1. Completely drain all Propylene Glycol Based / Recreational Vehicle (RV) antifreeze from the solution tank.
2. Rinse out the solution tank. Refer to DRAINING AND CLEANING THE SOLUTION TANK in the OPERATOR'S MANUAL for instructions how to clean the solution tank.
3. Pour 11.4 L (3 gal) of cool clean water into the solution tank.



4. Turn on the machine
5. Press the 1-STEP button.



6. Repeatedly press the Solution increase button (+) until the solution flow is at the highest setting.



7. Drive the machine to circulate the clean water completely through the system to clean out the RV antifreeze.
8. Press the 1-STEP button to turn off the system.
9. Machines equipped with the optional spray nozzle only: Operate the wand for a few seconds to clean the RV antifreeze from the pump.
10. Turn off the machine.
11. The remaining water does not need to be drained from the solution tank.

MAINTENANCE

FREEZE PROTECTION (MACHINES WITH OPTIONAL ec-H2O SYSTEM)

1. Completely drain the solution tank and recovery tank.
2. Disconnect the hose from the solenoid valve inlet port located on the bottom of the frame and allow all remaining solution to drain from the system.



3. Use between 13.8 – 27.6 kPa (2 – 4 psi) of compressed air to blow remaining solution from the disconnected hose.

FOR SAFETY: Wear eye and ear protection when using pressurized air or water.

4. Reconnect the hose to the solenoid valve inlet port.
5. Lift the operator seat open and engage the seat support bar.
6. Remove the ec-H2O compartment cover.

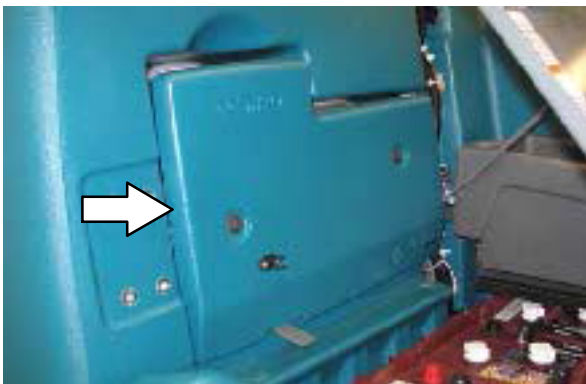

7. Remove the drain hose from the ec-H2O compartment.



8. Disconnect the outlet hose to the scrub head from the ec-H2O manifold hose.



9. Connect the drain hose to the ec-H2O manifold hose disconnected from the outlet hose in the previous step.



10. Pour 7.6 L (2 gal) of Propylene Glycol Based / Recreational Vehicle (RV) antifreeze into the solution tank.



11. Place the ec-H2O system outlet hose into an empty container.
12. Press and release the flush switch on the ec-H2O module to cycle the RV antifreeze through ec-H2O system. When the antifreeze appears in the container, press the switch again to turn off the module.

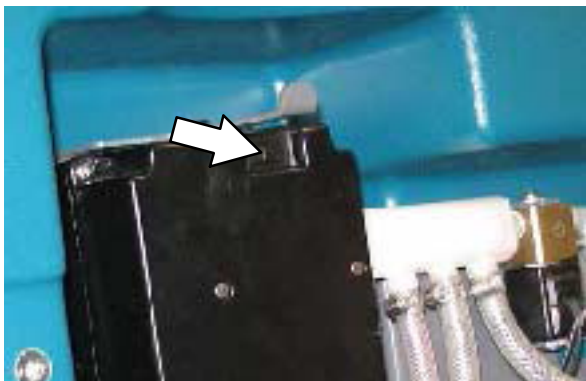

13. Disconnect the drain hose from the ec-H2O manifold hose.
14. Reconnect the outlet hose to the scrub head to the ec-H2O manifold hose.
15. Place the drain hose back into the ec-H2O compartment.
16. Reinstall the ec-H2O compartment cover.
17. Close the operator seat cover.

MAINTENANCE

PRIMING THE ec-H₂O SYSTEM

Prime the ec-H₂O system if the machine has been stored for a long period with no water in the solution tank / ec-H₂O system.

FOR SAFETY: Before leaving or servicing machine, stop on level surface and turn off machine.

1. Fill the solution tank with clean cool water. See FILLING THE SOLUTION TANK section of the OPERATOR'S MANUAL.



2. Remove the ec-H₂O compartment cover.

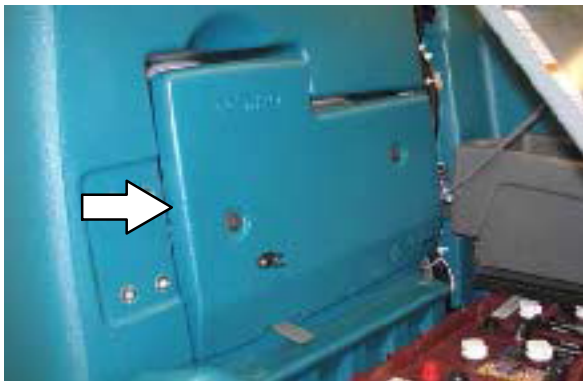

3. Remove the drain hose from the ec-H₂O compartment.



4. Disconnect the outlet hose to the scrub head from the ec-H₂O manifold hose.



5. Place the drain hose into an empty container.
6. Turn on the machine.
7. Press and release the ec-H₂O module flush switch. Allow the system to drain water into the container for 2 minutes.

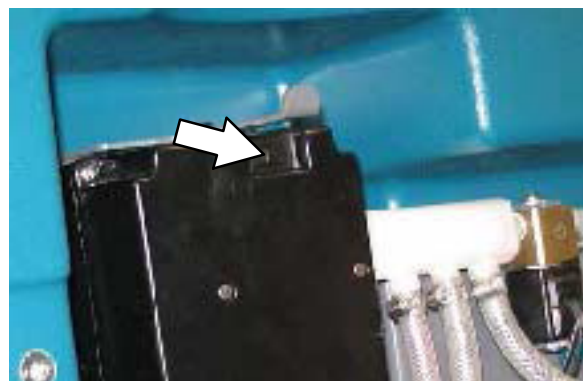

8. Press the ec-H₂O module flush switch to shut off the system.
9. Disconnect the drain hose from the ec-H₂O manifold hose.
10. Reconnect the outlet hose to the scrub head to ec-H₂O manifold hose.
11. Place the drain hose back into the ec-H₂O compartment.
12. Reinstall the ec-H₂O compartment cover.
13. Close the operator seat cover.

SECTION 4

| Contents | Page |
|--|-------------|
| Troubleshooting | |
| Onboard Diagnostics | 4-2 |
| Self-Test Mode | 4-2 |
| Configuration Mode | 4-4 |
| LCD Warnings | 4-6 |
| LCD Faults | 4-7 |
| Propel Diagnostic Mode | 4-9 |
| Curtis 1234 Controller Diagnostics | 4-11 |
| Diagnostic LED Operation | 4-11 |
| Diagnostic Codes | 4-12 |
| Input Display Mode | 4-20 |
| Manual Mode | 4-22 |
| Battery Charger, Standard | 4-24 |
| Operation | 4-24 |
| Configuration | 4-24 |
| Faults | 4-24 |
| Battery Charger, Onboard Option | 4-25 |
| Operation | 4-25 |
| Configuration, Lead-Acid/Gel | 4-25 |
| Faults | 4-25 |
| Subsystem Troubleshooting | 4-26 |
| Back-Up Alarm/Light | 4-26 |
| Electrical Schematic | 4-26 |
| Troubleshooting | 4-27 |
| Battery Charging | 4-28 |
| Electrical Schematic, Onboard | 4-28 |
| Troubleshooting | 4-29 |
| Electrical Schematic, Off Board | 4-30 |
| Troubleshooting | 4-31 |
| Parking Brake, Electromagnetic | 4-32 |
| Electrical Schematic | 4-32 |
| Troubleshooting | 4-33 |
| Detergent Metering | 4-34 |
| Electrical Schematic | 4-34 |
| Troubleshooting | 4-35 |
| Extended Scrub | 4-36 |
| Electrical Schematic | 4-36 |
| Troubleshooting | 4-37 |
| Lighting | 4-38 |
| Electrical Schematic | 4-38 |
| Troubleshooting | 4-39 |
| Main Scrub Brushes | 4-40 |
| Electrical Schematic | 4-40 |
| Troubleshooting | 4-41 |
| Power-Up | 4-42 |
| Electrical Schematic | 4-42 |
| Troubleshooting | 4-43 |

| Contents | Page |
|--|-------------|
| Subsystem Troubleshooting, continued | |
| Pre-Sweep Brushes | 4-44 |
| Electrical Schematic | 4-44 |
| Troubleshooting | 4-45 |
| Pre-Sweep Lift | 4-46 |
| Electrical Schematic, Down | 4-46 |
| Troubleshooting | 4-47 |
| Electrical Schematic, Up | 4-48 |
| Troubleshooting | 4-49 |
| Propel | 4-50 |
| Electrical Schematic | 4-50 |
| Troubleshooting | 4-51 |
| Rear Squeegee Lift | 4-52 |
| Electrical Schematic | 4-52 |
| Troubleshooting | 4-53 |
| Scrub Head Lift | 4-54 |
| Electrical Schematic | 4-54 |
| Troubleshooting | 4-55 |
| Side Brush | 4-56 |
| Electrical Schematic | 4-56 |
| Troubleshooting | 4-57 |
| Side Brush Lift | 4-58 |
| Electrical Schematic, Down | 4-58 |
| Troubleshooting | 4-59 |
| Electrical Schematic, Up | 4-60 |
| Troubleshooting | 4-61 |
| Solution Control, Conventional | 4-62 |
| Electrical Schematic | 4-62 |
| Troubleshooting | 4-63 |
| Solution Control, eCH ₂ O | 4-64 |
| Electrical Schematic | 4-64 |
| Troubleshooting | 4-65 |
| Solution Control, FaST | 4-66 |
| Electrical Schematic | 4-66 |
| Troubleshooting | 4-67 |
| Spray Nozzle | 4-68 |
| Electrical Schematic | 4-68 |
| Troubleshooting | 4-69 |
| Vacuum Fan(s), Scrubbing | 4-70 |
| Electrical Schematic | 4-70 |
| Troubleshooting | 4-71 |
| Vacuum Fan, Pre-Sweep | 4-72 |
| Electrical Schematic | 4-72 |
| Troubleshooting | 4-73 |

TROUBLESHOOTING

SELF TEST MODE

Self Test Mode is an onboard diagnostic utility that tests for open or shorted output circuits. Once completed, open and/or shorted output pins are displayed on the LCD (liquid crystal display).

1. Key switch Off. Press and hold the configuration mode button.

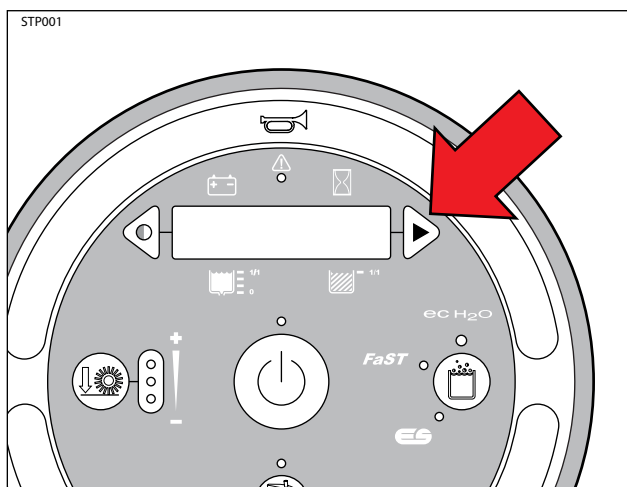

2. Key switch On. Release the configuration mode button when "CONFIG MODE" appears on the LCD.

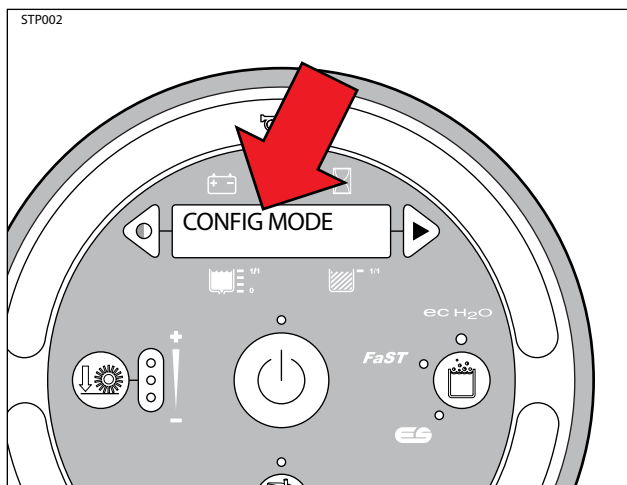

3. Press and release the configuration mode button to scroll through a list of utilities until "SELF TEST" appears on the LCD.

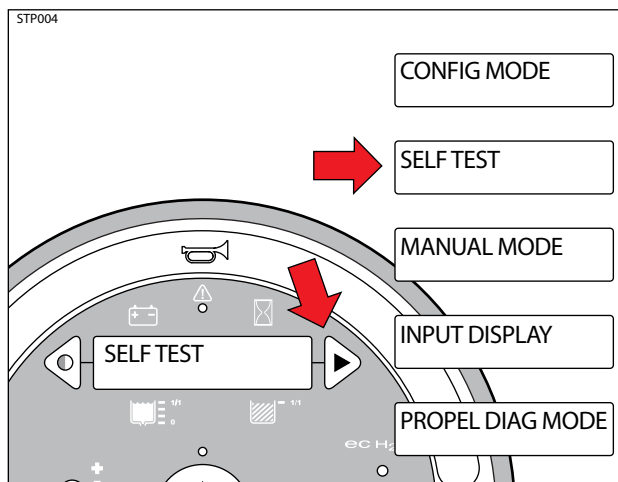

4. Press and release the brush pressure button to activate the self test. "SELF-TEST STARTING" will appear on the LCD.

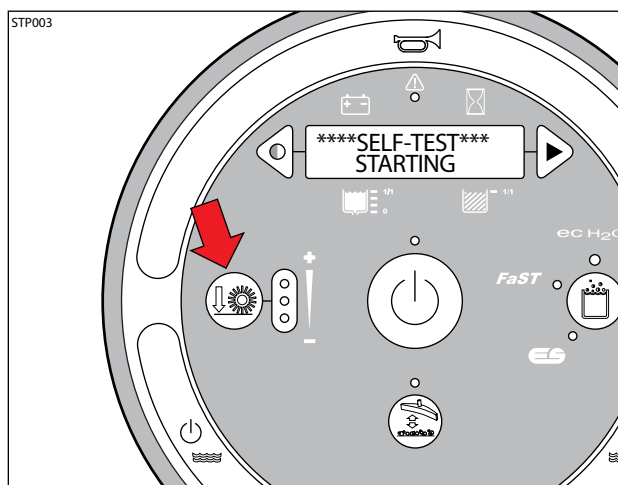

5. The controller sequentially tests each output circuit as shown below.

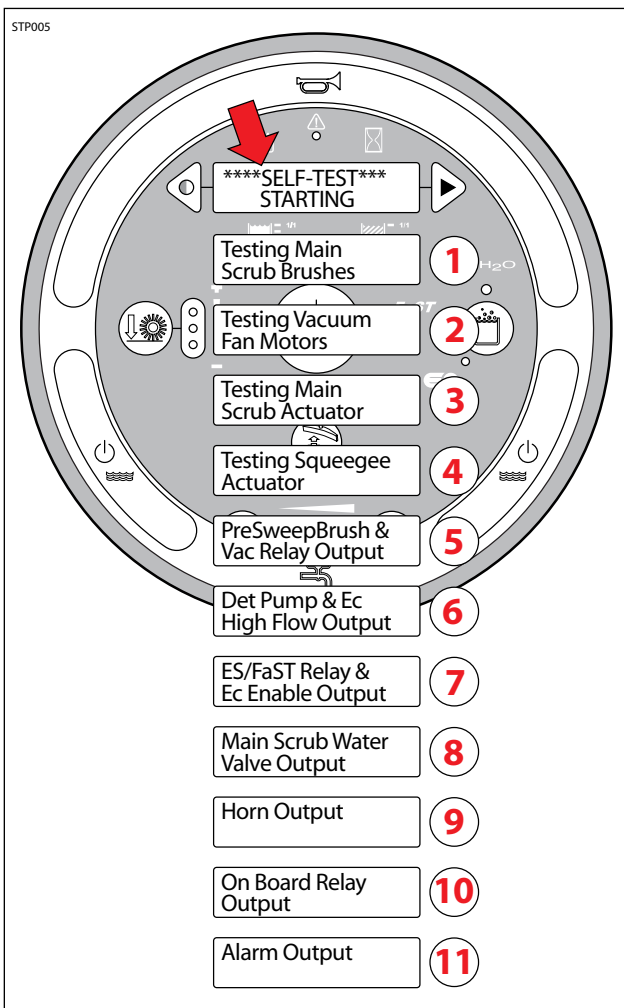

6. The self test results are displayed in "JX-X,X" format. JX = Connector, "-X,X" = Control board output pins as shown on the electrical schematic.

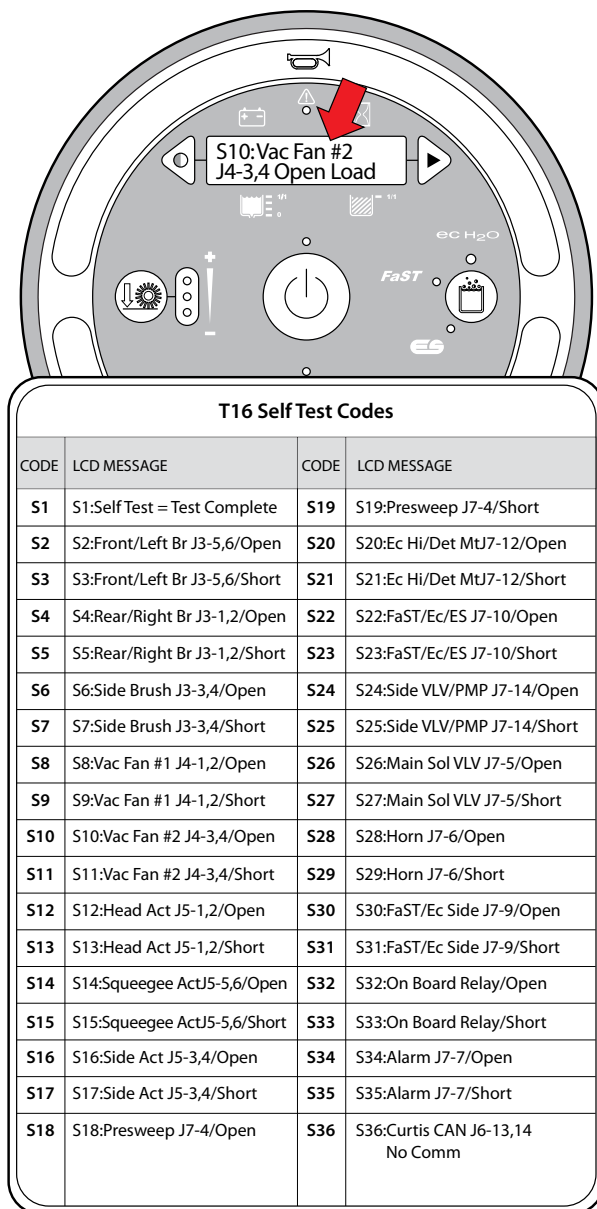

TROUBLESHOOTING

CONFIGURATION MODE

Configuration Mode is an onboard diagnostic utility that configures controller software to operate optional equipment and to electronically adjust certain output functions.

1. Key switch Off. Press and hold the configuration mode button.

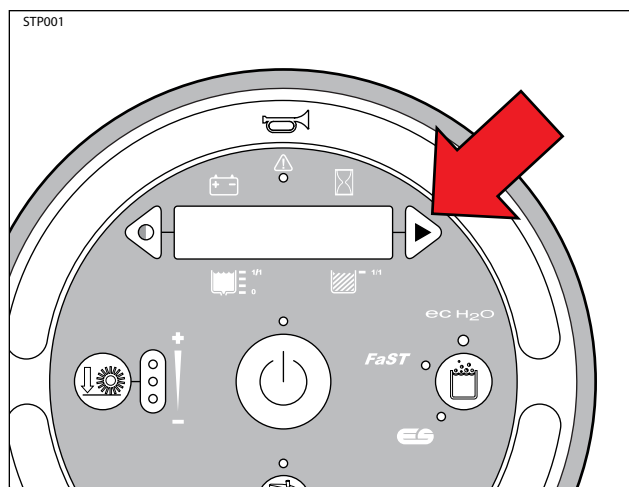

2. Key switch On. Release the configuration mode button when "CONFIG MODE" appears on the LCD.

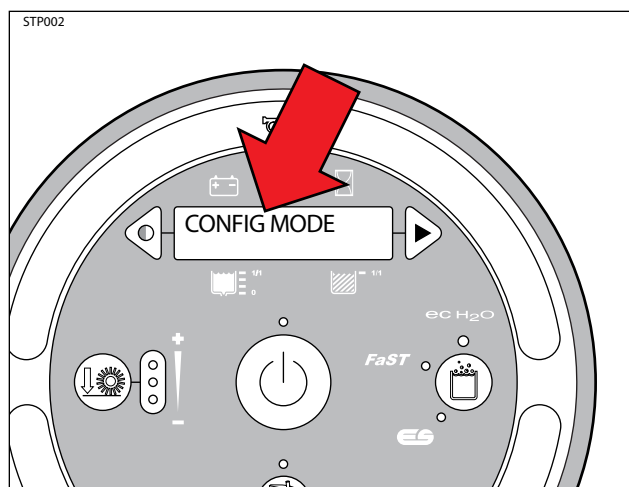

3. Press and release the brush pressure button to enter Configuration Mode. "C1:Disk/Cyl" will appear on the LCD.

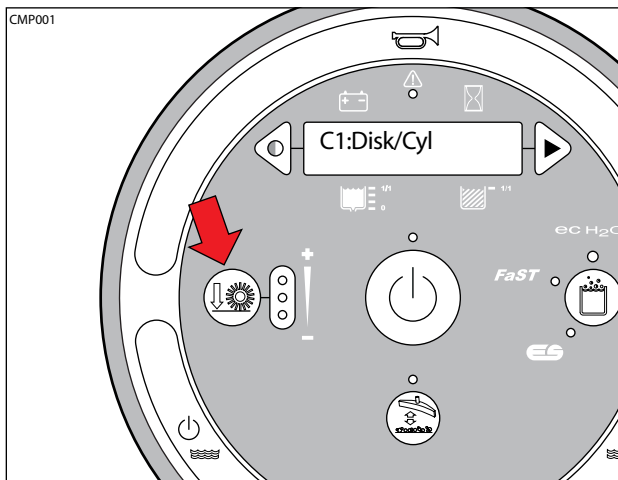

4. Press and release the configuration mode button to scroll through a list of utilities as shown below.

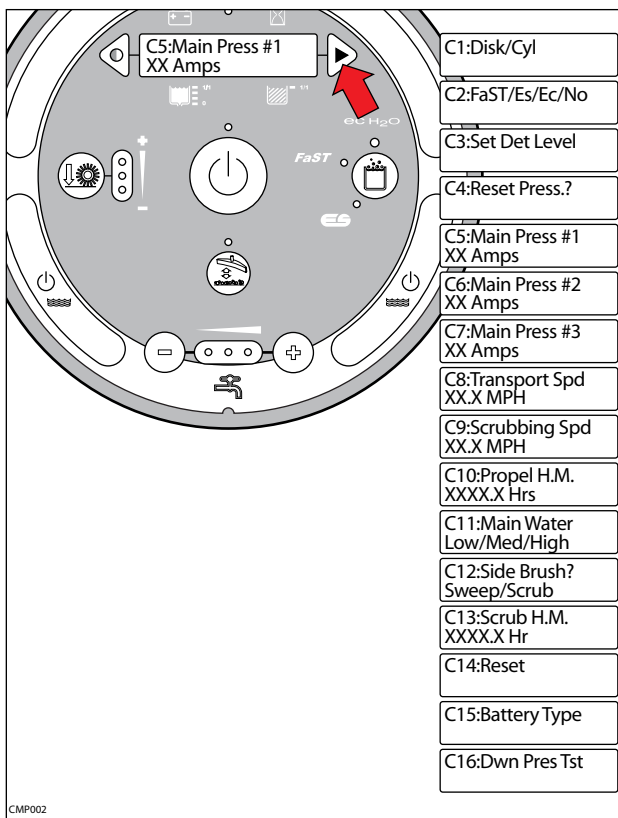

5. Use the table below for further description of each Configuration Mode utility.

| LCD TEXT | DESCRIPTION |
|-------------------------------|--|
| C1:Disk/Cyl | Configure scrub head type |
| C2:FaST/Es/Ec/No | Configure FaST/ES/ec-H2O |
| C3:Set Det Level | Configure detergent level |
| C4:Reset Press.? | Restore down pressure settings |
| C5:Main Press #1 | Set max down pressure #1 (11 Amps-Fixed) |
| C6:Main Press #2 | Set max down pressure #2 (11-16 Amps, Default 16 Amps) |
| C7:Main Press #3 | Set max down pressure #3 (11-22 Amps, Default 22 Amps) |
| C8:Transport Spd XX.X MPH | Adjust maximum forward transport mode speed |
| C9:Scrubbing Spd XX.X MPH | Adjust maximum forward scrub mode speed |
| C10:Propel H.M. XXXX.X Hrs | Display/edit propel hour meter. Password protected |
| C11:Main Water | Select water flow range: (Low, Medium, High) |
| C12:Side Brush? | Configure side brush option (sweep or scrub) |
| C13:Scrub H.M. XXXX.X Hr | Display/edit scrub hour meter. Password protected |
| C14:Reset | Restore factory default values. |
| C15:Battery Type | Configure battery type for acid or gel |
| C16:Dwn Pres Tst | Configure Down Pressure Test (Disable/Enable) |

NOTE: C16 Dwn Pres Tst (Down Pressure Test) pertains to checking cylindrical scrub brush and Pre-Sweep main broom patterns. See CHECKING CYLINDRICAL SCRUB BRUSH PATTERN in the MAINTENANCE section of this manual.

NOTE: C5, C6, and C7 Main Press (Main Brush Pressure) adjustments set the maximum brush motor amp draw for each down pressure setting; 1 LED, 2 LEDs, or 3 LEDs. C5 (#1) down pressure is not adjustable.

NOTE: C4:Reset Press.? mode. Press the brush pressure button after "No" changes to "Yes" following step 7. This completes the reset process.

6. Press and release the brush pressure button to enable the change. A "<" symbol will appear on the bottom line of the LCD indicating the configuration utility is now enabled.

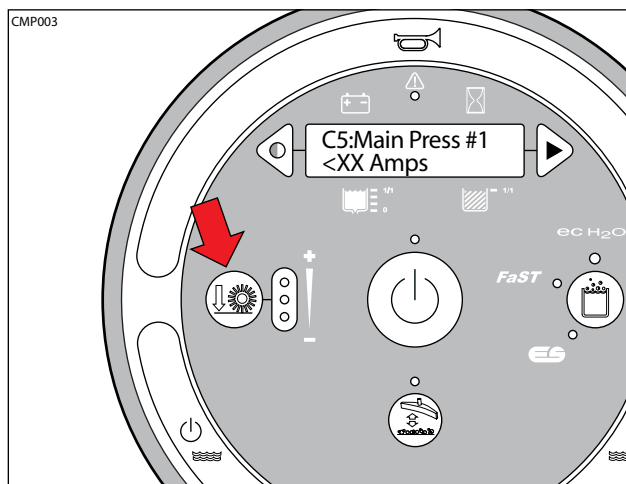

7. Press and release the contrast or configuration mode buttons to change settings. Turn key Off to save selection.

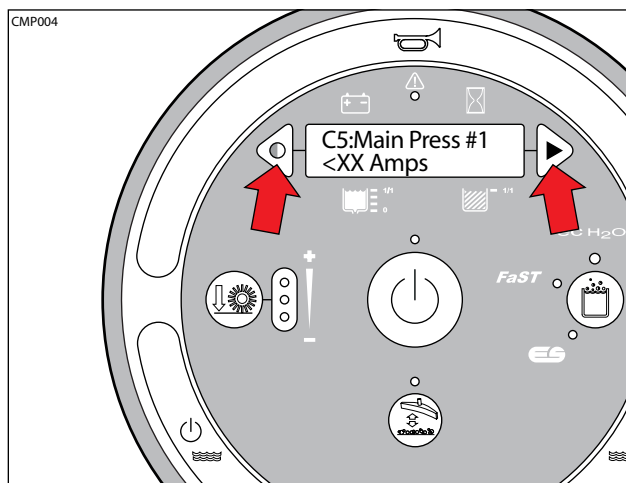

TROUBLESHOOTING

LCD Warnings

T16 LCD Warning Messages

| WARNING CODE | WARNING MESSAGE | WARNING DESCRIPTION | SET/CLEAR |
|--------------|--------------------|--------------------------------|---|
| W1 | W1:Batt Low | Low Battery | <i>SET:</i> Battery discharge threshold of 30-32 Volts at KSI terminal or 32-33 Volts at batteries. <i>CLEAR:</i> Charge batteries to BDI reset threshold of 37 Volts at KSI terminal or 38 Volts at batteries |
| W2 | W2:Sqge Stall | Rear Squeegee Actuator Stalled | <i>SET:</i> Rear squeegee actuator stall condition. <i>CLEAR:</i> Correct warning condition. |
| W3 | W3:Side Stall | Side Brush Actuator Stalled | <i>SET:</i> Side brush actuator stall condition. <i>CLEAR:</i> Correct warning condition. |
| W4 | W4:Unavailable | No Optional Solution Enabled | <i>SET:</i> Operator selects a solution technology that is not configured on the machine. <i>CLEAR:</i> Release button. |
| W5 | W5:No Side Brush | No Side Brush Enabled | <i>SET:</i> Operator selects the side brush when the side brush is not enabled in configuration mode. <i>CLEAR:</i> Release button. |
| W7 | W7:Not Active | Inactive Button | <i>SET:</i> Operator selects a button and the related function is inactive. <i>CLEAR:</i> Correct warning condition. |
| W8 | W8:No Vac Amps | Vacuum Fan Motor, No Current | <i>SET:</i> Controller senses no current to the vacuum fan circuit when the output is turned ON. <i>CLEAR:</i> Correct open circuit condition. |
| W9 | W9:Open R/R Brush | Open Right/Rear Brush Motor | <i>SET:</i> Controller senses no current to the Right (Disk) or Rear (Cyl) motor circuit when the output is turned ON. <i>CLEAR:</i> Correct open circuit condition. |
| W10 | W10:Open L/F Brush | Open Left/Front Brush Motor | <i>SET:</i> Controller senses no current to the Left (Disk) or Front (Cyl) motor circuit when the output is turned ON. <i>CLEAR:</i> Correct open circuit condition. |
| W11 | W11:Open SD Brush | Open Side Brush Motor | <i>SET:</i> Controller senses no current to the side brush motor circuit when the output is turned ON. <i>CLEAR:</i> Correct open circuit condition. |
| W12 | W12:Solution Off | Solution Water is Off | <i>SET:</i> Solution is OFF during scrub mode for 15 seconds. <i>CLEAR:</i> Correct warning condition. |

WMM001

LCD Faults

| T16 LCD Fault Messages | | | |
|------------------------|------------------|--|--|
| FAULT CODE | FAULT MESSAGE | FAULT DESCRIPTION | SET/CLEAR |
| F1 | F1:Rcv Tank Full | Recovery Tank Full | <i>SET:</i> Recovery tank full for 5 seconds. <i>CLEAR:</i> Recovery tank not full for 5 seconds. |
| F2 | F2:SolTank Empty | Solution Tank Empty | <i>SET:</i> Solution tank empty for 60 seconds <i>CLEAR:</i> Cycle key switch. |
| F3 | F3:Vac#Flt# | Over Current Vacuum Fan # (1 or 2) Motors, Fault Type (1, 2, 3). | <i>SET:</i> Fault #1 = Over Current for 15 Seconds; Fault #2 = Current Exceeds 25A for 30 Seconds; Fault #3 = Current Exceeds 35A for 2 Seconds. <i>CLEAR:</i> Cycle key switch. |
| F4 | F4:Batt Very Low | Very Low Battery Voltage | <i>SET:</i> Battery discharge threshold of 30.2 Volts at KSI terminal of PMC or 31.6 Volts at battery. <i>CLEAR:</i> Charge batteries to BDI reset threshold of 37 Volts at KSI terminal of PMC or 38.3 Volts at batteries. |
| F5 | F5:Propel Error | Propel Controller CAN-bus Connectivity Error | <i>SET:</i> Curtis 1234 PMC to T16 logic board CAN-bus connectivity problem or Curtis 1234 PMC power supply problem. <i>CLEAR:</i> See "Curtis 1234 Controller Diagnostics." |
| F6 | F6:Left Br Flt# | Left Brush Over Current, Fault # | <i>SET:</i> Fault #1 = Current Exceeds 30A for 30 Seconds; Fault #2 = Current Exceeds 40A for 5 Seconds; Fault #3 = Over Current for 10 Seconds. <i>CLEAR:</i> Cycle key switch. |
| F6 | F6:Frnt Br Flt# | Front Brush Over Current, Fault # | <i>SET:</i> Fault #1 = Current Exceeds 30A for 30 Seconds; Fault #2 = Current Exceeds 40A for 5 Seconds; Fault #3 = Over Current for 10 Seconds. <i>CLEAR:</i> Cycle key switch. |

FMM001

TROUBLESHOOTING

LCD Faults, continued

T16 LCD Fault Messages, continued

| FAULT CODE | FAULT MESSAGE | FAULT DESCRIPTION | SET/CLEAR |
|------------|---------------------|---|---|
| F7 | F7:Right Br Flt# | Right Brush Over Current, Fault # | <i>SET:</i> Fault #1 = Current Exceeds 30A for 30 Seconds; Fault #2 = Current Exceeds 40A for 5 Seconds; Fault #3 = Over Current for 10 Seconds. <i>CLEAR:</i> Cycle key switch. |
| F7 | F7:Rear Br Flt# | Rear Brush Over Current, Fault # | <i>SET:</i> Fault #1 = Current Exceeds 30A for 30 Seconds; Fault #2 = Current Exceeds 40A for 5 Seconds; Fault #3 = Over Current for 10 Seconds. <i>CLEAR:</i> Cycle key switch. |
| F8 | F8:Hi B3 Current | Over Current for Side Brush Motor | <i>SET:</i> Fault #1 = Current Exceeds 30A for 30 Seconds; Fault #2 = Current Exceeds 40A for 5 Seconds; Fault #3 = Over Current for 10 Seconds. <i>CLEAR:</i> Cycle key switch. |
| F11 | F11:Act Timeout | Main Head Actuator Timed Out Fault. | <i>SET:</i> No actuator stall current sensed after 60 seconds (lift cycle only). <i>CLEAR:</i> Correct fault condition and cycle key switch or 1-STEP scrub. |
| F12 | F12:Check Brushes | Check Main Brushes Error Fault (Down Shift) | <i>SET:</i> Controller failed to achieve minimum target brush motor current after down shifting to the lowest down pressure setting. <i>CLEAR:</i> Correct fault condition and cycle key switch. |
| F13 | F13:Brush Motor Flt | Brush Motor Fault | <i>SET:</i> Head lift actuator stalled while trying to reduce down pressure. <i>CLEAR:</i> Cycle key switch or 1-STEP scrub. |

FMM002

PROPEL DIAGNOSTIC MODE

Propel Diagnostic Mode (Propel Input Mode) is an on-board diagnostic utility that displays Curtis 1234 control inputs on the instrument panel LCD (Liquid Crystal Display). The input data is transmitted to the T16 controller through a CAN-bus (Controller Area Network).

1. Key switch Off. Press and hold the configuration mode button.

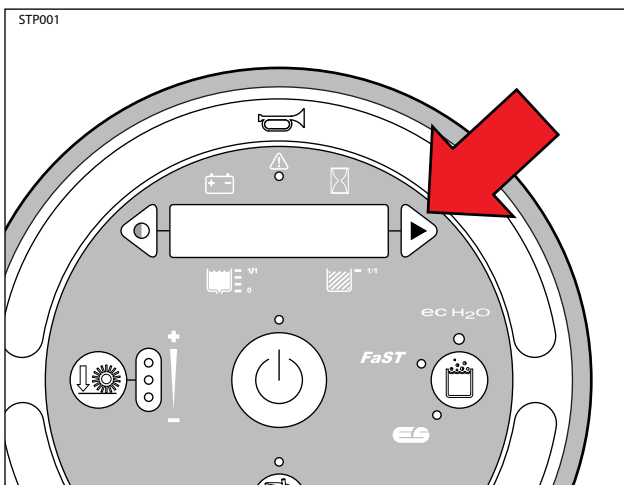

2. Key switch On. Release the configuration mode button when "CONFIG MODE" appears on the LCD.

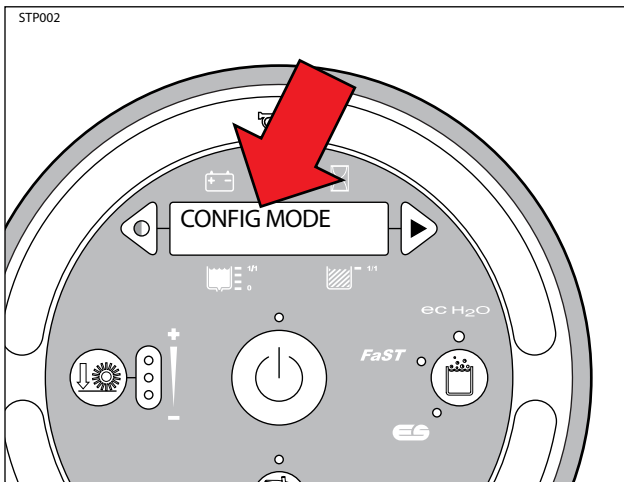

3. Press and release the configuration mode button to scroll through a list of utilities until "PROPEL DIAG MODE" appears on the LCD.

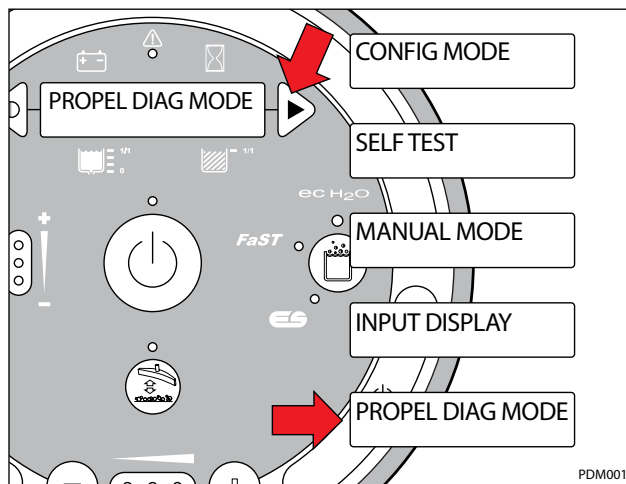

4. Press and release the brush pressure button to enter Propel Diagnostic Mode. "P1:Curtis Online..." will appear on the LCD.

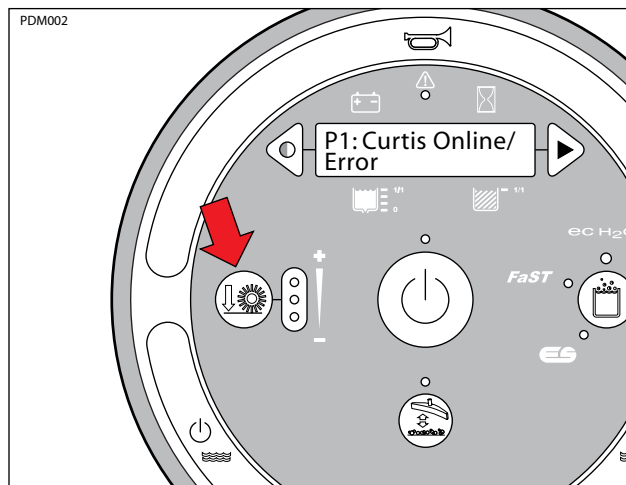

TROUBLESHOOTING

5. Press and release the configuration mode button to scroll through a list of Curtis 1234 controller inputs.

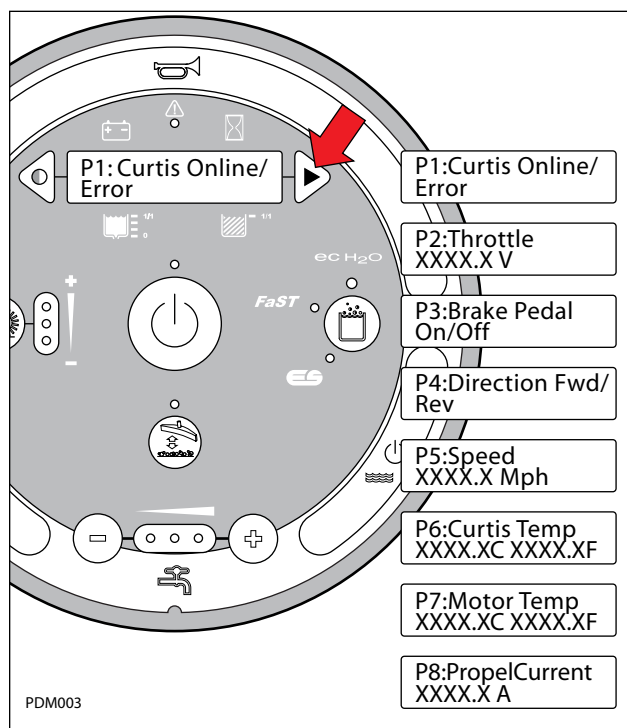

6. The table below describes how each input operates.

| T16 Propel Diagnostic Mode | | |
|----------------------------|-----------------------------------|---|
| CODE | LCD MESSAGE | DESCRIPTION |
| P1 | P1:Curtis Online/Error | Curtis/T16 controllers CAN-bus connection status |
| P2 | P2:Throttle XXXX.X v | Displays foot throttle commanded voltage (0-5V). |
| P3 | P3:Brake Pedal On/Off | Displays brake pedal command (On/Off). |
| P4 | P4:Direction Fwd/ Rev | Displays directional switch input (Fwd/Rev). |
| P5 | P5:Speed XXXX.X Mph | Displays propel speed from motor encoder located in drive assembly. |
| P6 | P6:Curtis Temp XXXX.XC XXXX.XF | Displays Curtis 1234 controller temperature |
| P7 | P7:Motor Temp XXXX.XC XXXX.XF | Displays drive motor temperature. Thermistor located in drive assembly. |
| P8 | P8:PropelCurrent XXXX.X A | Displays propel motor current. |

PDM004

Curtis 1234 Controller Diagnostic LED Operation

PMC002

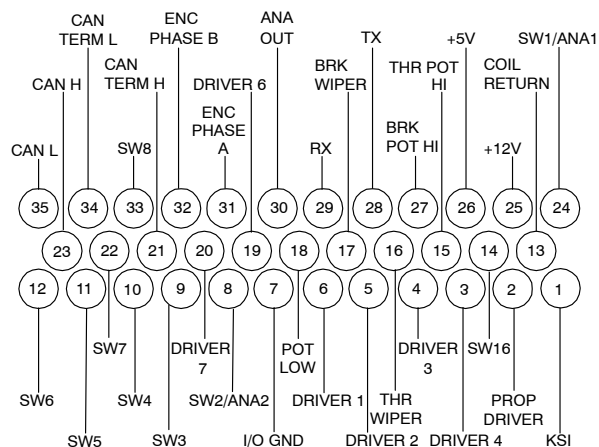
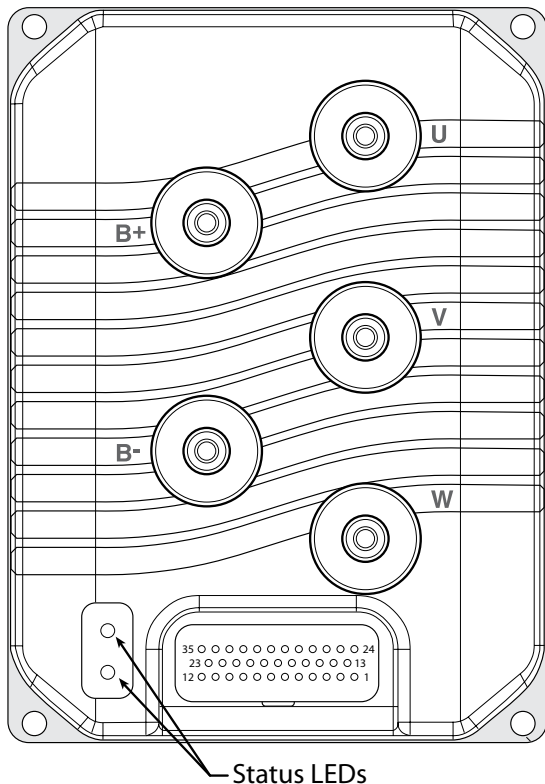

Types of LED Display

| Display | Status |
|---|--|
| Neither LED illuminated | Controller is not powered on, has a dead battery, or is severely damaged. |
| Yellow LED flashing | Controller is operating normally. |
| Yellow and red LEDs both on solid | Controller is in Flash program mode. |
| Red LED on solid | Watchdog failure. Cycle KSI to restart. |
| Red LED and yellow LED flashing alternately | Controller has detected a fault. 2-digit code* flashed by yellow LED identifies the specific fault; one or two flashes by red LED indicate whether first or second code digit will follow. |

*The red LED flashes once to indicate that the first digit of the code will follow; the yellow LED then flashes the appropriate number of times for the first digit. The red LED flashes twice to indicate that the second digit of the code will follow; the yellow LED flashes the appropriate number of times for the second digit.

Example: Battery Undervoltage (Code 23)



TROUBLESHOOTING

Curtis 1234 Controller Diagnostic Codes, continued

| TROUBLESHOOTING CHART | | | |
|-----------------------|---|--|--|
| CODE | FAULT CONDITION EFFECT OF FAULT | POSSIBLE CAUSE | SET/CLEAR CONDITIONS |
| 12 | Controller Overcurrent <i>ShutdownMotor;</i> <i>ShutdownMainContactor;</i> <i>ShutdownEMBrake;</i> <i>ShutdownThrottle;</i> <i>FullBrake;</i> <i>ShutdownPump.</i> | <ol style="list-style-type: none"> External short of phase U, V, or W motor connections. Motor parameters are mis-tuned. Controller defective. | <p><i>Set:</i> Phase current exceeded the current measurement limit.</p> <p><i>Clear:</i> Cycle KSI.</p> |
| 13 | Current Sensor Fault <i>ShutdownMotor;</i> <i>ShutdownMainContactor;</i> <i>ShutdownEMBrake;</i> <i>ShutdownThrottle;</i> <i>FullBrake;</i> <i>ShutdownPump.</i> | <ol style="list-style-type: none"> Leakage to vehicle frame from phase U, V, or W (short in motor stator). Controller defective. | <p><i>Set:</i> Controller current sensors have invalid offset reading.</p> <p><i>Clear:</i> Cycle KSI.</p> |
| 14 | Precharge Failed <i>ShutdownMotor;</i> <i>ShutdownMainContactor;</i> <i>ShutdownEMBrake;</i> <i>ShutdownThrottle;</i> <i>FullBrake;</i> <i>ShutdownPump.</i> | <ol style="list-style-type: none"> External load on capacitor bank (B+ connection terminal) that prevents the capacitor bank from charging. See Monitor menu » Battery: Capacitor Voltage. | <p><i>Set:</i> Precharge failed to charge the capacitor bank to the KSI voltage.</p> <p><i>Clear:</i> Cycle interlock input or use VCL function.</p> |
| 15 | Controller Severe Undertemp <i>ShutdownMotor;</i> <i>ShutdownMainContactor;</i> <i>ShutdownEMBrake;</i> <i>ShutdownThrottle;</i> <i>FullBrake;</i> <i>ShutdownPump.</i> | <ol style="list-style-type: none"> See Monitor menu » Controller: Temperature. Controller is operating in an extreme environment. | <p><i>Set:</i> Heatsink temperature below -40°C.</p> <p><i>Clear:</i> Bring heatsink temperature above -40°C, and cycle interlock or KSI.</p> |
| 16 | Controller Severe Overtemp <i>ShutdownMotor;</i> <i>ShutdownMainContactor;</i> <i>ShutdownEMBrake;</i> <i>ShutdownThrottle;</i> <i>FullBrake;</i> <i>ShutdownPump.</i> | <ol style="list-style-type: none"> See Monitor menu » Controller: Temperature. Controller is operating in an extreme environment. Excessive load on vehicle. Improper mounting of controller. | <p><i>Set:</i> Heatsink temperature above +95°C.</p> <p><i>Clear:</i> Bring heatsink temperature below +95°C, and cycle interlock or KSI.</p> |
| 17 | Severe Undervoltage <i>Reduced drive torque.</i> | <ol style="list-style-type: none"> Battery Menu parameters are misadjusted. Non-controller system drain on battery. Battery resistance too high. Battery disconnected while driving. See Monitor menu » Battery: Capacitor Voltage. Blown B+ fuse or main contactor did not close. | <p><i>Set:</i> Capacitor bank voltage dropped below the severe undervoltage limit with FET bridge enabled.</p> <p><i>Clear:</i> Bring capacitor voltage above severe undervoltage limit.</p> |

Curtis 1234 Controller Diagnostic Codes, continued

| TROUBLESHOOTING CHART, continued | | | |
|----------------------------------|--|--|---|
| CODE | FAULT CONDITION <i>EFFECT OF FAULT</i> | POSSIBLE CAUSE | SET/CLEAR CONDITIONS |
| 18 | Severe Overvoltage <i>ShutdownMotor; ShutdownMainContactor; ShutdownEMBrake; ShutdownThrottle; FullBrake; ShutdownPump.</i> | <ol style="list-style-type: none"> 1. See Monitor menu » Battery: Capacitor Voltage. 2. Battery menu parameters are misadjusted. 3. Battery resistance too high for given regen current. 4. Battery disconnected while regen braking. | <p><i>Set:</i> Capacitor bank voltage exceeded the Severe Overvoltage limit with FET bridge enabled.</p> <p><i>Clear:</i> Bring capacitor voltage below Severe Overvoltage limit, and then cycle KSI.</p> |
| 22 | Controller Overtemp Cutback <i>Reduced drive and brake torque.</i> | <ol style="list-style-type: none"> 1. See Monitor menu » Controller: Temperature. 2. Controller is performance-limited at this temperature. 3. Controller is operating in an extreme environment. 4. Excessive load on vehicle. 5. Improper mounting of controller. | <p><i>Set:</i> Heatsink temperature exceeded 85°C.</p> <p><i>Clear:</i> Bring heatsink temperature below 85°C.</p> |
| 23 | Undervoltage Cutback <i>Reduced drive torque.</i> | <ol style="list-style-type: none"> 1. Normal operation. Fault shows that the batteries need recharging. Controller is performance limited at this voltage. 2. Battery parameters are misadjusted. 3. Non-controller system drain on battery. 4. Battery resistance too high. 5. Battery disconnected while driving. 6. See Monitor menu » Battery: Capacitor Voltage. 7. Blown B+ fuse or main contactor did not close. | <p><i>Set:</i> Capacitor bank voltage dropped below the Undervoltage limit with the FET bridge enabled.</p> <p><i>Clear:</i> Bring capacitor voltage above the Undervoltage limit.</p> |
| 24 | Overvoltage Cutback <i>Reduced brake torque.</i> | <ol style="list-style-type: none"> 1. Normal operation. Fault shows that regen braking currents elevated the battery voltage during regen braking. Controller is performance limited at this voltage. 2. Battery parameters are misadjusted. 3. Battery resistance too high for given regen current. 4. Battery disconnected while regen braking. 5. See Monitor menu » Battery: Capacitor Voltage. | <p><i>Set:</i> Capacitor bank voltage exceeded the Overvoltage limit with the FET bridge enabled.</p> <p><i>Clear:</i> Bring capacitor voltage below the Overvoltage limit.</p> |
| 25 | +5V Supply Failure <i>None, unless a fault action is programmed in VCL.</i> | <ol style="list-style-type: none"> 1. External load impedance on the +5V supply (pin 26) is too low. 2. See Monitor menu » outputs: 5 Volts and Ext Supply Current. | <p><i>Set:</i> +5V supply (pin 26) outside the +5V +/-10% range.</p> <p><i>Clear:</i> Bring voltage within range.</p> |
| 26 | Digital Out 6 Overcurrent <i>Digital Output 6 driver will not turn on.</i> | <ol style="list-style-type: none"> 1. External load impedance on Digital Output 6 driver (pin 19) is too low. | <p><i>Set:</i> Digital Output 6 (pin 19) current exceeded 15 mA.</p> <p><i>Clear:</i> Remedy the overcurrent cause and use the VCL function <i>Set_DigOut()</i> to turn the driver on again.</p> |

VC004

TROUBLESHOOTING

Curtis 1234 Controller Diagnostic Codes, continued

| TROUBLESHOOTING CHART, continued | | | |
|----------------------------------|---|--|--|
| CODE | FAULT CONDITION EFFECT OF FAULT | POSSIBLE CAUSE | SET/CLEAR CONDITIONS |
| 27 | Digital Out 7 Overcurrent <i>Digital Output 7 driver will not turn on.</i> | 1. External load impedance on Digital Output 7 driver (pin 20) is too low. | <i>Set:</i> Digital Output 7 (pin 20) current exceeded 15 mA. <i>Clear:</i> Remedy the overcurrent cause and use the VCL function Set_DigOut() to turn the driver on again. |
| 28 | Motor Temp Hot Cutback <i>Reduced drive torque.</i> | 1. Motor temperature is at or above the programmed Temperature Hot setting, and the requested current is being cut back. 2. Motor Temperature Control Menu parameters are mis-tuned. 3. See Monitor menu » Motor: Temperature and » Inputs: Analog2. 4. If the application doesn't use a motor thermistor, Temp Compensation and Temp Cutback should be programmed Off. | <i>Set:</i> Motor temperature is at or above the Temperature Hot parameter setting. <i>Clear:</i> Bring the motor temperature within range. |
| 29 | Motor Temp Sensor Fault <i>MaxSpeed reduced (LOS, Limited Operating Strategy), and motor temperature cutback disabled.</i> | 1. Motor thermistor is not connected properly. 2. If the application does not use a thermistor, Temp Compensation and Temp Cutback should be programmed Off. 3. See Monitor menu » Motor: Temperature and » Inputs: Analog2. | <i>Set:</i> Motor thermistor input (pin 8) is at the voltage rail (0 or 10V). <i>Clear:</i> Bring the motor thermistor input voltage within range. |
| 31 | Coil1 Driver Open/Short <i>ShutdownDriver1.</i> | 1. Open or short on driver load. 2. Dirty connector pins. 3. Bad crimps or faulty wiring. | <i>Set:</i> Driver 1 (pin 60) is either open or shorted. <i>Clear:</i> Correct open or short, and cycle driver. |
| 31 | Main Open/Short <i>ShutdownMotor; ShutdownMainContactor; ShutdownEMBrake; ShutdownThrottle; FullBrake; ShutdownPump.</i> | 1. Open or short on driver load. 2. Dirty connector pins. 3. Bad crimps or faulty wiring. | <i>Set:</i> Main contactor driver (pin 6) is either open or shorted. <i>Clear:</i> Correct open or short, and cycle driver. |
| 32 | Coil2 Driver Open/Short <i>ShutdownDriver2.</i> | 1. Open or short on driver load. 2. Dirty connector pins. 3. Bad crimps or faulty wiring. | <i>Set:</i> Driver 2 (pin 5) is either open or shorted. <i>Clear:</i> Correct open or short, and cycle driver. |
| 32 | EMBrake Open/Short <i>ShutdownEMBrake; ShutdownThrottle; FullBrake.</i> | 1. Open or short on driver load. 2. Dirty connector pins. 3. Bad crimps or faulty wiring. | <i>Set:</i> Electromagnetic brake driver (pin 5) is either open or shorted. <i>Clear:</i> Correct open or short, and cycle driver. |
| 33 | Coil3 Driver Open/Short <i>ShutdownDriver3.</i> | 1. Open or short on driver load. 2. Dirty connector pins. 3. Bad crimps or faulty wiring. | <i>Set:</i> Driver 3 (pin 4) is either open or shorted. <i>Clear:</i> Correct open or short, and cycle driver. |
| 34 | Coil4 Driver Open/Short <i>ShutdownDriver4.</i> | 1. Open or short on driver load. 2. Dirty connector pins. 3. Bad crimps or faulty wiring. | <i>Set:</i> Driver 4 (pin3) is either open or shorted. <i>Clear:</i> Correct open or short, and cycle driver. |

PMC005

Curtis 1234 Controller Diagnostic Codes, continued

| TROUBLESHOOTING CHART, continued | | | |
|---|--|--|---|
| CODE | FAULT CONDITION <i>EFFECT OF FAULT</i> | POSSIBLE CAUSE | SET/CLEAR CONDITIONS |
| 35 | PD Open/Short <i>ShutdownPD.</i> | <ol style="list-style-type: none"> 1. Open or short on driver load. 2. Dirty connector pins. 3. Bad crimps or faulty wiring. | <p><i>Set:</i> Proportional driver (pin 2) is either open or shorted.</p> <p><i>Clear:</i> Correct open or short, and cycle driver.</p> |
| 36 | Encoder Fault <i>ShutdownEMBrake.</i> | <ol style="list-style-type: none"> 1. Motor encoder failure. 2. Bad crimps or faulty wiring. 3. See Monitor menu » Motor: Motor RPM. | <p><i>Set:</i> Motor encoder phase failure detected.</p> <p><i>Clear:</i> Cycle KSI.</p> |
| 37 | Motor Open <i>ShutdownMotor;</i> <i>ShutdownMainContactor;</i> <i>ShutdownEMBrake;</i> <i>ShutdownThrottle;</i> <i>FullBrake;</i> <i>ShutdownPump.</i> | <ol style="list-style-type: none"> 1. Motor phase is open. 2. Bad crimps or faulty wiring. | <p><i>Set:</i> Motor phase U, V, or W detected open.</p> <p><i>Clear:</i> Cycle KSI.</p> |
| 38 | Main Contactor Welded <i>ShutdownMotor;</i> <i>ShutdownMainContactor;</i> <i>ShutdownEMBrake;</i> <i>ShutdownThrottle;</i> <i>FullBrake;</i> <i>ShutdownPump.</i> | <ol style="list-style-type: none"> 1. Main contactor tips are welded closed. 2. Motor phase U or V is disconnected or open. 3. An alternate voltage path (such as an external precharge resistor) is providing a current to the capacitor bank (B+ connection terminal). | <p><i>Set:</i> Just prior to the main contactor closing, the capacitor bank voltage (B+ connection terminal) was loaded for a short time and the voltage did not discharge.</p> <p><i>Clear:</i> Cycle KSI</p> |
| 39 | Main Contactor Did Not Close <i>ShutdownMotor;</i> <i>ShutdownMainContactor;</i> <i>ShutdownEMBrake;</i> <i>ShutdownThrottle;</i> <i>FullBrake;</i> <i>ShutdownPump.</i> | <ol style="list-style-type: none"> 1. Main contactor did not close. 2. Main contactor tips are oxidized, burned, or not making good contact. 3. External load on capacitor bank (B+ connection terminal) that prevents capacitor bank from charging. 4. Blown B+ fuse. | <p><i>Set:</i> With the main contactor commanded closed, the capacitor bank voltage (B+ connection terminal) did not charge to B+.</p> <p><i>Clear:</i> Cycle KSI.</p> |
| 41 | Throttle Wiper High <i>ShutdownThrottle.</i> | <ol style="list-style-type: none"> 1. See Monitor menu » Inputs: Throttle Pot. 2. Throttle pot wiper voltage too high. | <p><i>Set:</i> Throttle pot wiper (pin 16) voltage is higher than the high fault threshold (can be changed with the VCL function Setup_Pot_Faults())</p> <p><i>Clear:</i> Bring throttle pot wiper voltage below the fault threshold.</p> |
| 42 | Throttle Wiper Low <i>ShutdownThrottle.</i> | <ol style="list-style-type: none"> 1. See Monitor menu » Inputs: Throttle Pot. 2. Throttle pot wiper voltage too low. | <p><i>Set:</i> Throttle pot wiper (pin 16) voltage is lower than the low fault threshold (can be changed with the VCL function Setup_Pot_Faults()).</p> <p><i>Clear:</i> Bring throttle pot wiper voltage above the fault threshold.</p> |
| 43 | Pot2 Wiper High <i>FullBrake.</i> | <ol style="list-style-type: none"> 1. See Monitor menu » Inputs: Pot2 Raw. 2. Pot2 wiper voltage too high. | <p><i>Set:</i> Pot2 wiper (pin 17) voltage is higher than the high fault threshold (can be changed with the VCL function Setup_Pot_Faults()).</p> <p><i>Clear:</i> Bring Pot2 wiper voltage below the fault threshold.</p> |

PMC006

TROUBLESHOOTING

Curtis 1234 Controller Diagnostic Codes, continued

| TROUBLESHOOTING CHART, continued | | | |
|----------------------------------|---|---|---|
| CODE | FAULT CONDITION EFFECT OF FAULT | POSSIBLE CAUSE | SET/CLEAR CONDITIONS |
| 44 | Pot2 Wiper Low <i>FullBrake.</i> | <ol style="list-style-type: none"> See Monitor menu » Inputs: Pot2 Raw. Pot2 wiper voltage too low. | <p><i>Set:</i> Pot2 wiper (pin 17) voltage is lower than the low fault threshold (can be changed with the VCL function Setup_Pot_Faults()).</p> <p><i>Clear:</i> Bring Pot2 wiper voltage above the fault threshold.</p> |
| 45 | Pot Low Overcurrent <i>ShutdownThrottle;</i> <i>FullBrake.</i> | <ol style="list-style-type: none"> See Monitor menu » Outputs: Pot Low. Combined pot resistance connected to pot low is too low. | <p><i>Set:</i> Pot low (pin 18) current exceeds 10 mA.</p> <p><i>Clear:</i> Clear pot low overcurrent condition and cycle KSI.</p> |
| 46 | EEPROM Failure <i>ShutdownMotor;</i> <i>ShutdownMainContactor;</i> <i>ShutdownEMBrake;</i> <i>ShutdownThrottle;</i> <i>ShutdownInterlock;</i> <i>ShutdownDriver1;</i> <i>ShutdownDriver2;</i> <i>ShutdownDriver3;</i> <i>ShutdownDriver4;</i> <i>ShutdownPD;</i> <i>FullBrake;</i> <i>ShutdownPump.</i> | <ol style="list-style-type: none"> Failure to write to EEPROM memory. This can be caused by EEPROM memory writes initiated by VCL, by the CAN bus, by adjusting parameters with the programmer, or by loading new software into the controller. | <p><i>Set:</i> Controller operating system tried to write to EEPROM memory and failed.</p> <p><i>Clear:</i> Download the correct software (OS) and matching parameter default settings into the controller and cycle KSI.</p> |
| 47 | HPD/Sequencing Fault <i>ShutdownThrottle.</i> | <ol style="list-style-type: none"> KSI, interlock, direction, and throttle inputs applied in incorrect sequence. Faulty wiring, crimps, or switches at KSI, interlock, direction, or throttle inputs. See Monitor menu » Inputs. | <p><i>Set:</i> HPD (High Pedal Disable) or sequencing fault caused by incorrect sequence of KSI, interlock, direction and throttle inputs.</p> <p><i>Clear:</i> Reapply inputs in correct sequence.</p> |
| 47 | Emer Rev HPD <i>ShutdownThrottle;</i> <i>ShutdownEMBrake.</i> | <ol style="list-style-type: none"> Emergency Reverse operation has concluded, but the throttle, forward and reverse inputs, and interlock have not been returned to neutral. | <p><i>Set:</i> At the conclusion of Emergency Reverse, the fault was set because various inputs were not returned to neutral.</p> <p><i>Clear:</i> If EMR_Interlock = On, clear the interlock, throttle, and direction inputs. If EMR_Interlock = Off, clear the throttle and direction inputs.</p> |
| 49 | Parameter Change Fault <i>ShutdownMotor;</i> <i>ShutdownMainContactor;</i> <i>ShutdownEMBrake;</i> <i>ShutdownThrottle;</i> <i>FullBrake;</i> <i>ShutdownPump.</i> | <ol style="list-style-type: none"> This is a safety fault caused by a change in certain parameter settings so that the vehicle will not operate until KSI is cycled. For example, if a user changes the Throttle Type this fault will appear and require cycling KSI before the vehicle can operate. | <p><i>Set:</i> Adjustment of a parameter setting that requires cycling of KSI.</p> <p><i>Clear:</i> Cycle KSI</p> |

PMC007

Curtis 1234 Controller Diagnostic Codes, continued

| TROUBLESHOOTING CHART, continued | | | |
|---|--|---|--|
| CODE | FAULT CONDITION <i>EFFECT OF FAULT</i> | POSSIBLE CAUSE | SET/CLEAR CONDITIONS |
| 68 | VCL Run Time Error <i>ShutdownMotor;</i> <i>ShutdownMainContactor;</i> <i>ShutdownEMBrake;</i> <i>ShutdownThrottle;</i> <i>ShutdownInterlock;</i> <i>ShutdownDriver1;</i> <i>ShutdownDriver2;</i> <i>ShutdownDriver3;</i> <i>ShutdownDriver4;</i> <i>ShutdownPD;</i> <i>FullBrake;</i> <i>ShutdownPump.</i> | <ol style="list-style-type: none"> 1. VCL code encountered a runtime VCL error. 2. See Monitor menu » Controller: VCL Error Module and VCL Error. This error can then be compared to the runtime VCL module ID and error code definitions found in the specific OS system information file. | <i>Set:</i> Runtime VCL code error condition. <i>Clear:</i> Edit VCL application software to fix this error condition; flash the new compiled software and matching parameter defaults; cycle KSI. |
| 69 | External Supply Out of Range <i>None, unless a fault action is programmed in VCL.</i> | <ol style="list-style-type: none"> 1. External load on the 5V and 12V supplies draws either too much or too little current. 2. Fault Checking Menu parameters Ext Supply Max and Ext Supply Min are mis-tuned. 3. See Monitor menu » Outputs: Ext Supply Current. | <i>Set:</i> The external supply current (combined current used by the 5V supply [pin 26] and 12V supply [pin 25]) is either greater than the lower current threshold. The two thresholds are defined by the External Supply Max and External Supply Min parameter settings. <i>Clear:</i> Bring the external supply current within range. |
| 71 | OS General <i>ShutdownMotor;</i> <i>ShutdownMainContactor;</i> <i>ShutdownEMBrake;</i> <i>ShutdownThrottle;</i> <i>ShutdownInterlock;</i> <i>ShutdownDriver1;</i> <i>ShutdownDriver2;</i> <i>ShutdownDriver3;</i> <i>ShutdownDriver4;</i> <i>ShutdownPD;</i> <i>FullBrake;</i> <i>ShutdownPump.</i> | <ol style="list-style-type: none"> 1. Internal controller fault. | <i>Set:</i> Internal controller fault detected. <i>Clear:</i> Cycle KSI |
| 72 | PDO Timeout <i>ShutdownInterlock;</i> <i>CAN NMT State set to Pre-operational.</i> | <ol style="list-style-type: none"> 1. Time between CAN PDO messages received exceeded the PDO Timeout Period. | <i>Set:</i> Time between CAN PDO messages received exceeded the PDO Timeout Period. <i>Clear:</i> Cycle KSI. |
| 73 | Stall Detected <i>ShutdownEMBrake.</i> | <ol style="list-style-type: none"> 1. Stalled motor. 2. Motor encoder failure. 3. Bad crimps or faulty wiring. 4. Problems with power supply for the motor encoder. 5. See Monitor menu » Motor: Motor RPM. | <i>Set:</i> No motor encoder movement detected. <i>Clear:</i> Either cycle KSI, or detect valid motor encoder signals while operating in LOS mode and return Throttle Command = 0 and Motor RPM= 0 |

Curtis 1234 Controller Diagnostic Codes, continued

| TROUBLESHOOTING CHART, continued | | | |
|----------------------------------|--|---|---|
| CODE | FAULT CONDITION EFFECT OF FAULT | POSSIBLE CAUSE | SET/CLEAR CONDITIONS |
| 87 | Motor Characterization Fault <i>ShutdownMotor;</i> <i>ShutdownMainContactor;</i> <i>ShutdownEMBrake;</i> <i>ShutdownThrottle;</i> <i>FullBrake;</i> <i>ShutdownPump.</i> | 1. Motor characterization failed during characterization process. See Monitor menu » Controller: Motor Characterization Error for cause: 0=none 1=encoder signal seen, but step size not determined; set Encoder Step Size manually 2=motor temp sensor fault 3=motor temp hot cutback fault 4= controller overtemp cutback fault 5=controller undertemp cutback fault 6=undervoltage cutback fault 7=severe overvoltage fault 8=encoder signal not seen, or one or both channels missing 9=motor parameters out of characterization range. | <i>Set:</i> Motor characterization failed during the motor characterization process. <i>Clear:</i> Correct fault; cycle KSI. |
| 89 | Motor Type Fault <i>ShutdownMotor;</i> <i>ShutdownMainContactor;</i> <i>ShutdownEMBrake;</i> <i>ShutdownThrottle;</i> <i>FullBrake;</i> <i>ShutdownPump.</i> | 1. The Motor_Type parameter value is out of range. | <i>Set:</i> Motor_Type parameter is set to an illegal value. <i>Clear:</i> Set Motor_Type to correct value and cycle KSI. |
| 91 | VCL/OS Mismatch <i>ShutdownMotor;</i> <i>ShutdownMainContactor;</i> <i>ShutdownEMBrake;</i> <i>ShutdownThrottle;</i> <i>ShutdownInterlock;</i> <i>ShutdownDriver1;</i> <i>ShutdownDriver2;</i> <i>ShutdownDriver3;</i> <i>ShutdownDriver4;</i> <i>ShutdownPD;</i> <i>FullBrake;</i> <i>ShutdownPump.</i> | 1. The VCL software in the controller does not match the OS software in the controller. | <i>Set:</i> VCL and OS software do not match; when KSI cycles, a check is made to verify that they match and a fault is issued when they do not. <i>Clear:</i> Download the correct VCL and OS software into the controller. |
| 92 | EM Brake Failed to Set <i>ShutdownEMBrake;</i> <i>ShutdownThrottle.</i> | 1. Vehicle movement sensed after the EM Brake has been commanded to set. 2. EM Brake will not hold the motor from rotating. | <i>Set:</i> After the EM Brake was commanded to set and time has elapsed to allow the brake to fully engage, vehicle movement has been sensed. <i>Clear:</i> Activate the throttle. |
| 93 | Encoder LOS (Limited Operating Strategy) <i>Enter LOS control mode.</i> | 1. Limited Operating Strategy (LOS) control mode has been activated, as a result of either an Encoder Fault (Code 36) or a Stall Detect Fault (Code 73). 2. Motor encoder failure. 3. Bad crimps or faulty wiring. 4. Vehicle is stalled. | <i>Set:</i> Encoder Fault (Code 36) or Stall Detect Fault (Code 73) was activated, and Brake or Interlock has been applied to activate LOS control mode, allowing limited motor control. <i>Clear:</i> Cycle KSI, or if LOS mode was activated by the Stall Fault, clear by ensuring encoder senses proper operation, Motor RPM = 0, and Throttle Command = 0. |

PMC009

Curtis 1234 Controller Diagnostic Codes, continued

| TROUBLESHOOTING CHART, continued | | | |
|----------------------------------|--|--|---|
| CODE | FAULT CONDITION EFFECT OF FAULT | POSSIBLE CAUSE | SET/CLEAR CONDITIONS |
| 94 | Emer Rev Timeout <i>ShutdownEMBrake;</i> <i>ShutdownThrottle.</i> | <ol style="list-style-type: none"> 1. Emergency Reverse was activated and concluded because the EMR Timeout timer has expired. 2. The emergency reverse input is stuck On. | <p><i>Set:</i> Emergency Reverse was activated and ran until the EMR Timeout timer expired.</p> <p><i>Clear:</i> Turn the emergency reverse input Off.</p> |
| 98 | Illegal Model Number <i>ShutdownMotor;</i> <i>ShutdownMainContactor;</i> <i>ShutdownEMBrake;</i> <i>ShutdownThrottle;</i> <i>FullBrake;</i> <i>ShutdownPump.</i> | <ol style="list-style-type: none"> 1. Model_Number variable contains illegal value (not 1234, 1236, 1238, or 1298). 2. Software and hardware do not match. 3. Controller defective. | <p><i>Set:</i> Illegal Model_Number variable; when KSI cycles a check is made to confirm a legal Model_Number, and a fault is issued if one is not found.</p> <p><i>Clear:</i> Download appropriate software for your controller model.</p> |

TROUBLESHOOTING

INPUT DISPLAY MODE

Input Display Mode is an onboard diagnostic utility that displays controller input conditions. Input Display Mode displays LCD text messages for hard-wired switch, sensor, and touch panel button inputs.

1. Key switch Off. Press and hold the configuration mode button.

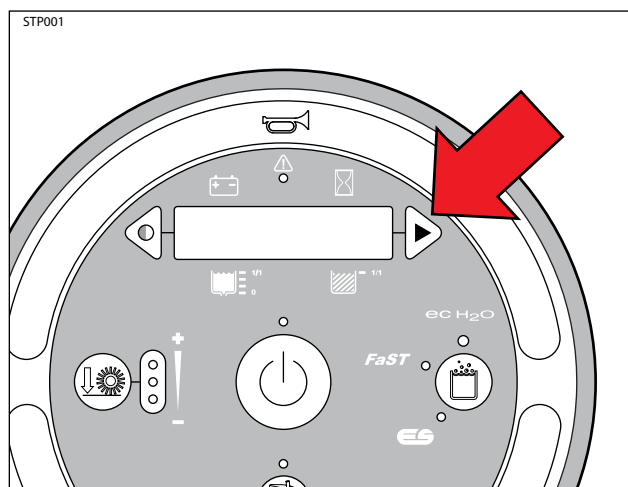

2. Key switch On. Release the configuration mode button when "CONFIG MODE" appears on the LCD.

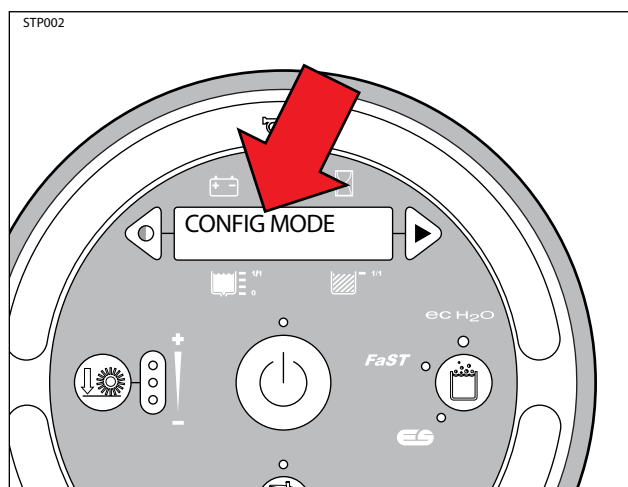

3. Press and release the configuration mode button to scroll through a list of utilities until "INPUT DISPLAY" appears on the LCD.

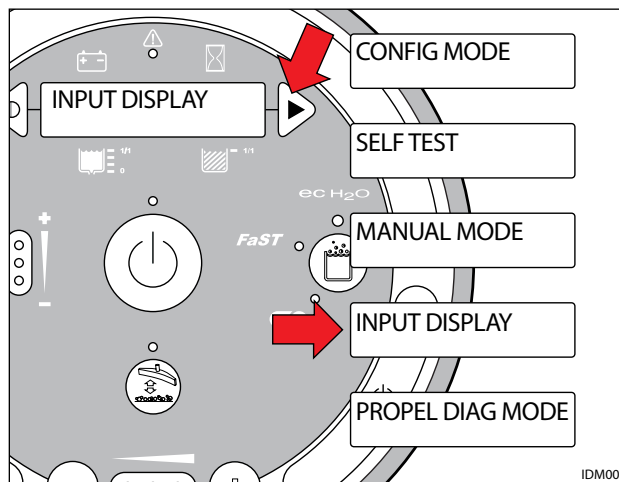

4. Press and release the brush pressure button to enter Input Display Mode. "I1:Sol Tank, XXXX Filt(Raw)" will appear on the LCD.

NOTE: "XXXX Filt(Raw)" refers to encrypted software code and should be ignored in the "I1" input mode utility. The numbers "2(2)," as shown below, represent the solution tank water level from 1 to 5 bars on the LCD. For example, when filling an empty solution tank, the numbers will increase gradually from 0(0) to 5(5) in a 0(0), 0(1), 1(1), 1(2), 2(2), 2(3)... sequence.

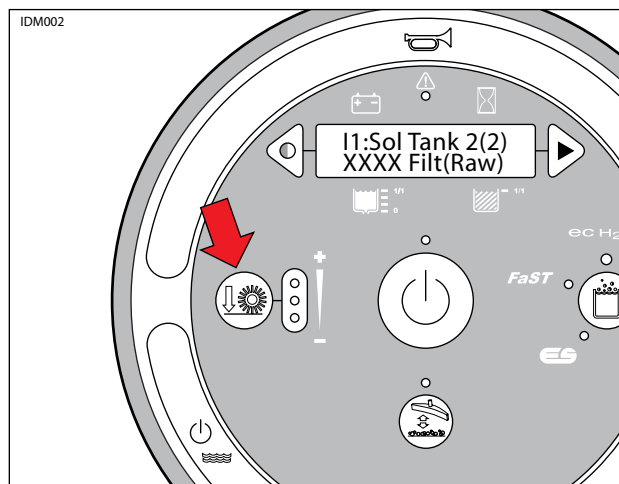

- Press and release the configuration mode button to scroll through a list of hard-wired switch and sensor inputs.

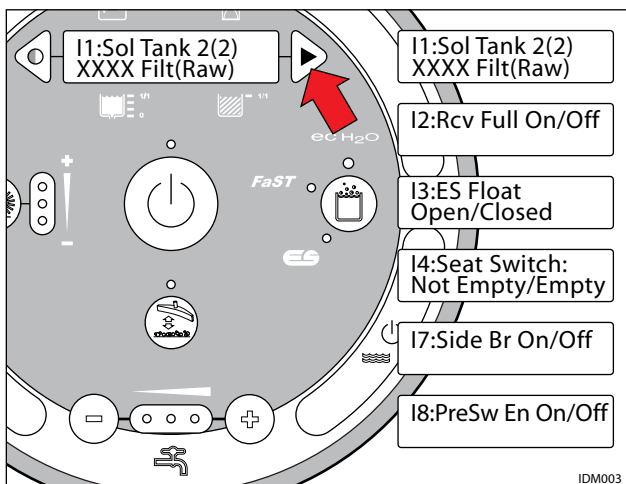

- Press any touch panel button to display a corresponding LCD text message. The message confirms that the control board received the input.

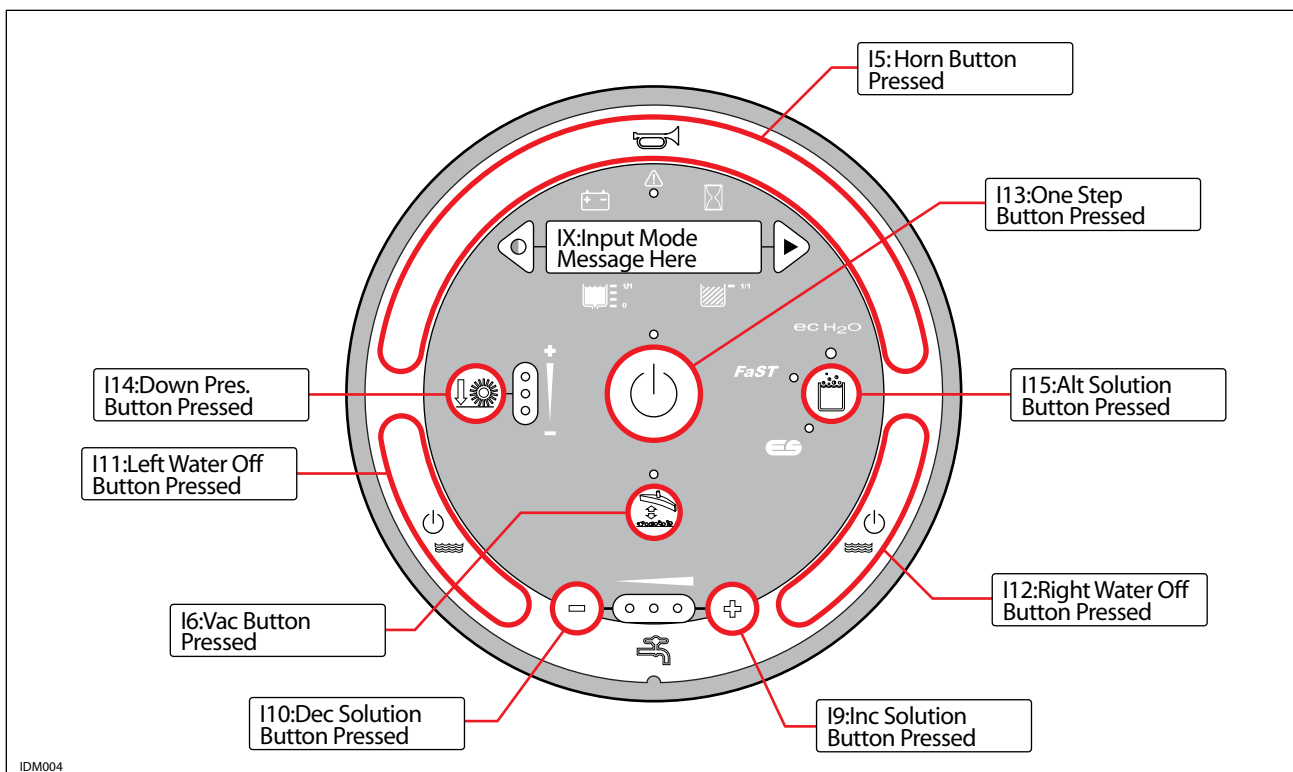

TROUBLESHOOTING

MANUAL MODE

Manual Mode is an onboard diagnostic utility that manually activates machine functions and displays output current in "XX.X Amps" format. This mode bypasses interlocking inputs and should be used for diagnostic purposes only.

1. Key switch Off. Press and hold the configuration mode button.

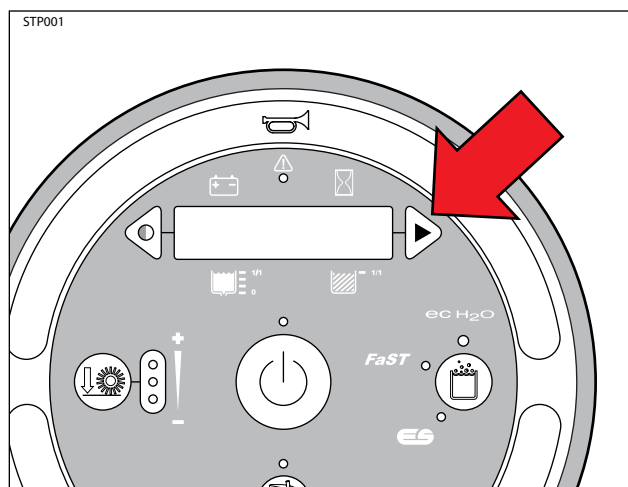

2. Key switch On. Release the configuration mode button when "CONFIG MODE" appears on the LCD.

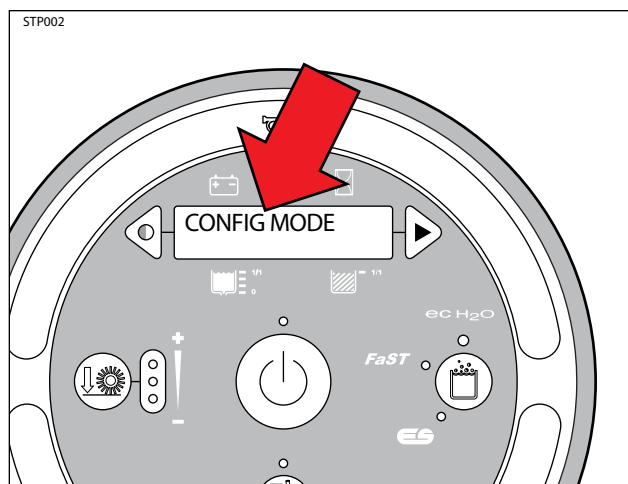

3. Press and release the configuration mode button to scroll through a list of utilities until "MANUAL MODE" appears on the LCD.

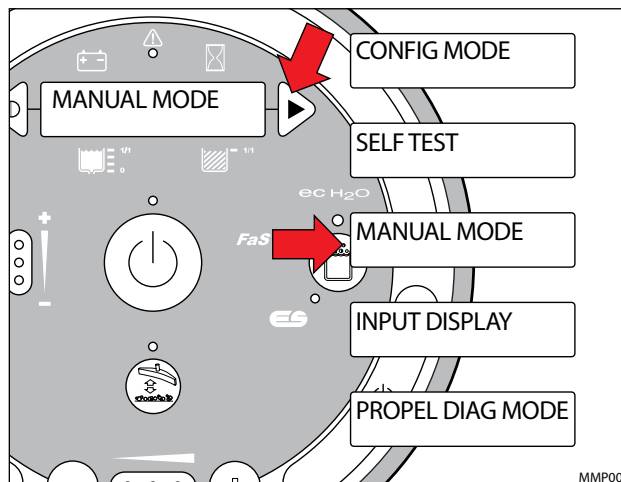

4. Press and release the brush pressure button to enter Manual Mode. "Manual Mode On..." will appear on the LCD.

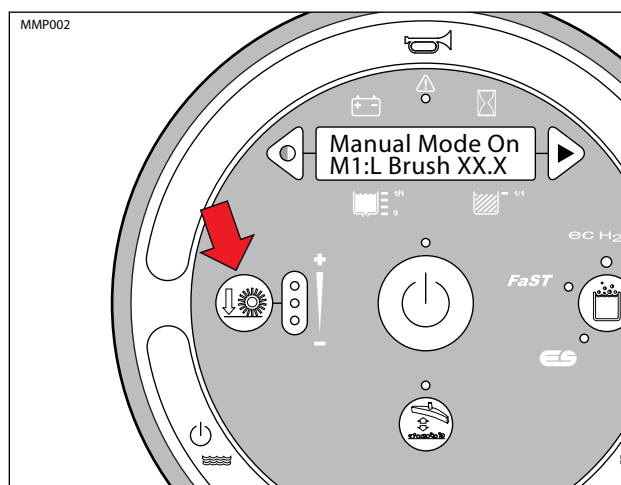

- Press and release the configuration mode button to scroll through a list of output functions. Press the brush down pressure button to select a specific output function.

NOTE: The XX.X format indicates that the actual amperage value will vary. See the "Specifications" section of this manual for approximate amp draw values .

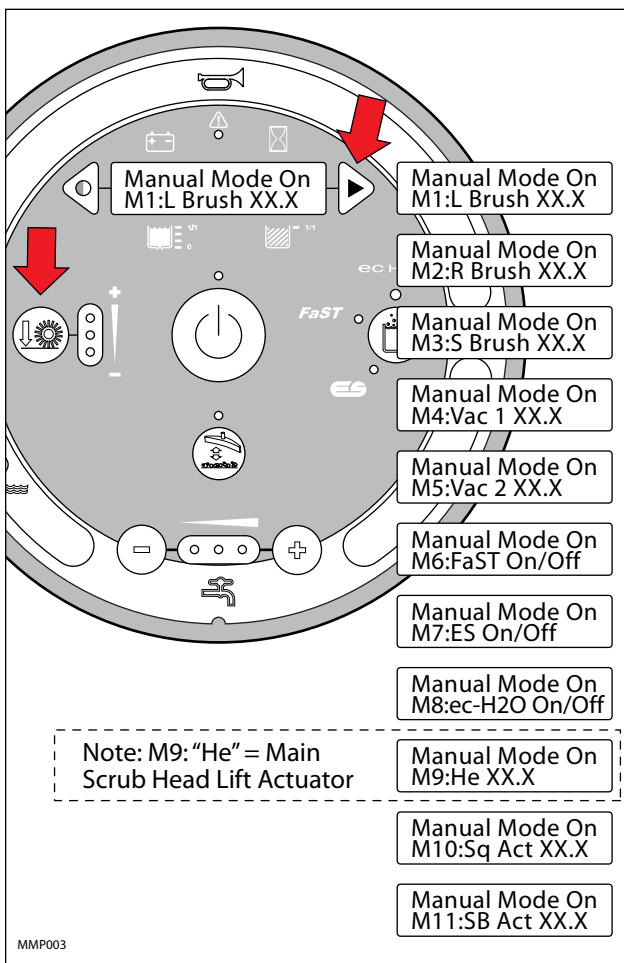

- Enable specific output functions by using the table below.

NOTE: Outputs requiring multiple button activation must be pressed and released in sequence.

NOTE: Conventional solution control is manually operated with the scrub brushes. The solution control LEDs will need to be activated while in scrub brushes - manual mode.

| T16 Manual Mode Operation | |
|---------------------------------------|---|
| FUNCTION | ENABLE |
| | DISABLE |
| Scrub Brushes | 1-STEP Scrub Button On <i>1-STEP Scrub button toggles On/Off</i> |
| Side Brush | Side brush switch On + Horn button <i>Horn button toggles On/Off</i> |
| Vacuum Fan(s), Scrubbing | Vacuum Fan/Squeegee Button <i>Vacuum Fan/Squeegee button toggles On/Off</i> |
| FaST Pump <i>*If Configured</i> | FaST button On <i>FaST button toggles On/Off</i> |
| ES Pump <i>*If Configured</i> | ES button On <i>ES button toggles On/Off</i> |
| ecH2O Module <i>*If Configured</i> | ecH2O button On <i>ecH2O button toggles On/Off</i> |
| Scrub Head Lift Actuator | Brush Pressure, Water Flow (-), 1-STEP On <i>Brush down pressure button disables</i> |
| Rear Squeegee Lift Actuator | Brush Pressure, Water Flow (-), Vac/Sq On <i>Brush down pressure button disables</i> |
| Side Brush Lift Actuator | Brush Pressure, Water Flow (-), Horn Button <i>Brush down pressure button disables</i> |

MMP004

TROUBLESHOOTING

Battery Charger, Standard

OPERATION

The standard battery charger utilizes a single-LED display. The LED flashes green during the charging cycle and changes to solid green when the charging cycle is complete.

This charger is programmable for standard lead-acid, heavy duty lead-acid batteries. The setting is displayed using the blink on/off method each time the battery charger is connected to an AC power supply and the charger is disconnected from the batteries.

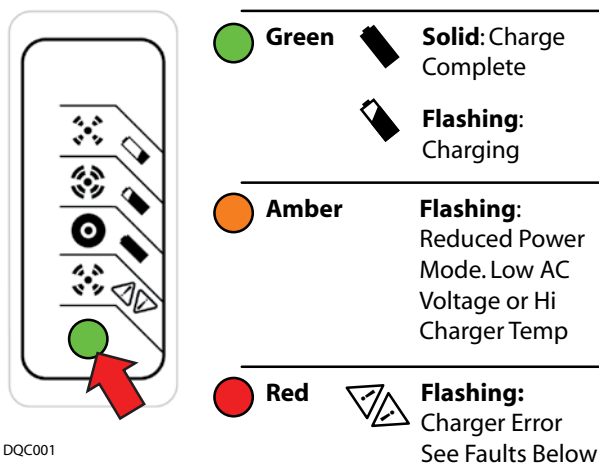

DQC001

CONFIGURATION

DISPLAYING CURRENT CHARGER SETTING

1. Key Off. Disconnect battery charger from AC power supply and the batteries. Wait 30 seconds before proceeding to step 2 to allow for capacitor discharge.
2. Connect charger to AC supply and observe the LED display. It will blink on/off to indicate the current battery charger setting for 11 seconds.

| ALGORITHM # | BATTERY TYPE |
|-------------|-------------------|
| 3 | Lead-Acid, 235 Ah |
| 7 | Lead-Acid, 360 Ah |

CHANGING CHARGER SETTING

1. Key Off. Disconnect battery charger from AC power supply and the batteries. Wait 30 seconds before proceeding to step 2 to allow for capacitor discharge.

2. Connect charger to AC supply and observe the LED display. It will blink on/off to indicate the current battery charger setting for 11 seconds.
3. Connect the battery charger to the batteries for 2 seconds and then disconnect from the batteries, during the 11 second window, to advance to the next highest setting.

NOTE: The 11 second window expands to 30 seconds after the first change has been made.

NOTE: There are 10 total algorithms. The advancement sequence increases each time and then loops back to #1.

4. Wait 45 seconds after a change has been made to save the new charger setting.

FAULTS

A flashing red LED indicates a charger error. Count the number of flashes separated by a long pause and then use the table below to identify a possible cause.

| RED FLASHES | POSSIBLE CAUSE |
|-------------|--|
| 1 | Battery High Voltage |
| 2 | Battery Low Voltage |
| 3 | Charge timeout. Batteries failed to reach required voltage. Charger output was reduced due to high temperatures. |
| 4 | Check battery. Battery could not be trickle charged up to minimum voltage. |
| 5 | Over-Temperature: Charger shut down due to high internal temperature. |
| 6 | Charger internal fault. Disconnect for 15 seconds and reset charger. |

Battery Charger, Onboard (Option)

OPERATION

The onboard battery charger utilizes a 4 character digital display, 3 control indicator LEDs and a scroll button. The red control indicator illuminates at the beginning of the charging cycle. The yellow control indicator illuminates when the final phase of the charging cycle begins and the green control indicator illuminates when the charging cycle is complete.

Each time the battery charger is connected to an AC power supply, the charger displays; "SPE," the software revision date, battery voltage, charging current, charging curve number, and finally the words "GEL" (Gel) or "Acid" (Lead-Acid) depending on how the charger is configured from the factory.

Pressing the scroll button during the charge cycle will change the display mode between; A (charging current), U (battery voltage), h (charging time), C (charging amp-hours), and E (energy used KWh).

CONFIGURATION, LEAD ACID/GEL

1. Key Off. Disconnect battery charger from AC power supply and the batteries.
2. Carefully remove the charger display cover decal to access the programmable dip switches.
3. Use the table below to set the dip switches for Lead-Acid or Gel batteries.

NOTE: The dip switches below are shown in the default Lead-Acid position.

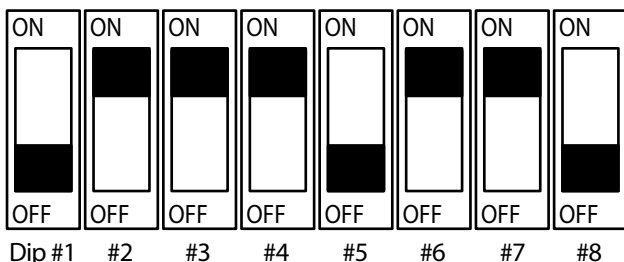

OBC005

| TYPE | #1 | #2 | #3 | #4 | #5 | #6 | #7 | #8 |
|-------------|-----|----|----|----|-----|----|----|-----|
| GEL | ON | ON | ON | ON | OFF | ON | ON | OFF |
| ACID | OFF | ON | ON | ON | OFF | ON | ON | OFF |

FAULTS

Fault messages automatically display when a fault exists. Use the table below to identify possible causes.

| FAULT | POSSIBLE CAUSE |
|-------|--|
| "bat" | Poor or no battery connection or reversed polarity |
| "E01" | Maximum battery voltage exceeded. |
| "E02" | Maximum battery temperature exceeded. |
| "E03" | Maximum charging time exceeded. |
| "Sct" | The total safety timer has interrupted charging. |
| "Srt" | Internal charger short circuit possible. |

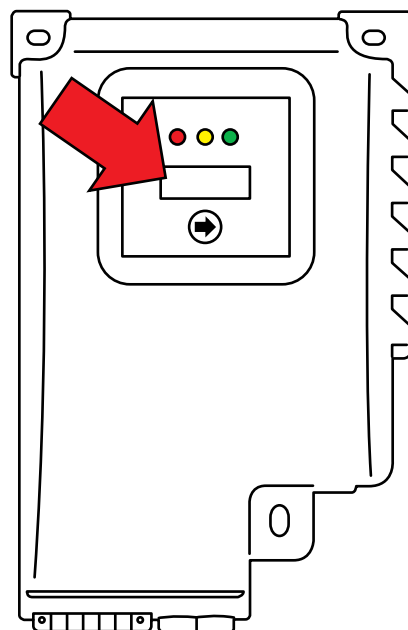

OBC003

TROUBLESHOOTING

Back-Up Alarm/Light ON

Note: Key Switch ON

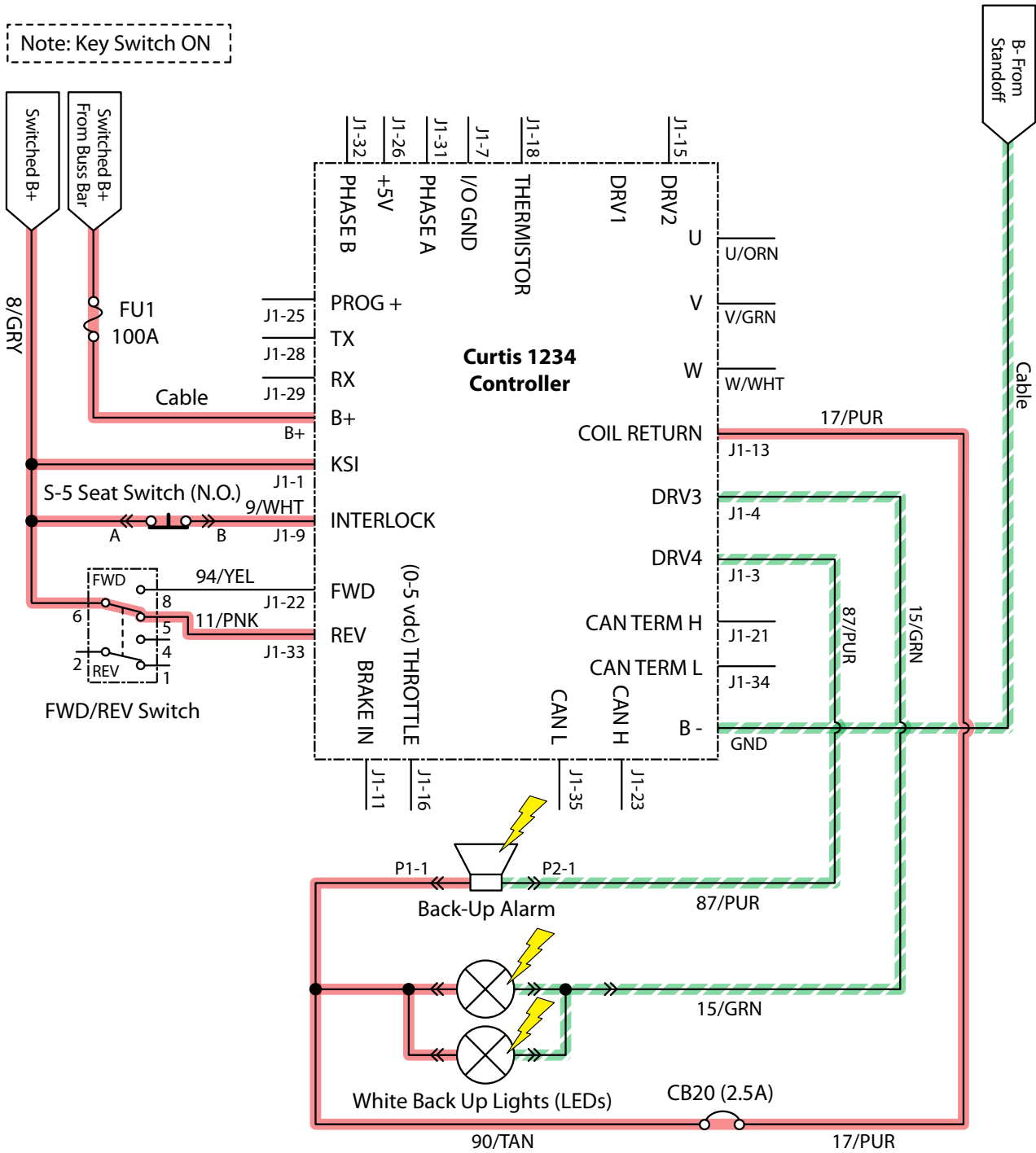

- Battery Positive +
- Battery Negative -

Operational Matrix:

| | Enabled | Disabled |
|-----------------------------|--|--|
| Back-Up Alarm/Lights | <ul style="list-style-type: none"> • Rev Switch Input • Rev Throttle Command | <ul style="list-style-type: none"> • Fwd Switch Input • Neutral - Ready State • Curtis 1234 Fault |

PMCO11

Back-Up Alarm/Light Failed to Turn ON

| STEP | ACTION | VALUE(S) | YES | NO |
|------|--|----------|---|--------------------------------|
| 1 | <ul style="list-style-type: none"> • Key On • Enable back-up alarm/lights • Is there a pertinent LCD warning or fault message displayed? | | See "LCD Warnings" or "LCD Faults" Sections | Go to Step #2 |
| 2 | <ul style="list-style-type: none"> • Key On • Enable back-up alarm/lights • See "Curtis 1234 Controller Diagnostics" • Is there a pertinent Curtis 1234 fault displayed? | | Correct Fault Condition | Go to Step #3 |
| 3 | <ul style="list-style-type: none"> • Key Off • See "Propel Diagnostic Mode" section of this manual • Check the "P4:Direction Fwd/Rev" input from the directional switch • Check the "P2:Throttle" (0-5 vdc) input from the directional pedal • Are the P2 and P4 inputs operating properly? | | Go to Step # 4 | Correct Faulty Input Condition |
| 4 | <ul style="list-style-type: none"> • Key Off • Disconnect back-up alarm/light from main harness • Apply battery voltage to back-up alarm/light using fuse-protected jumper leads • Does the back-up alarm/light turn On? | | Go to Step #5 | Replace Back-Up Alarm/Light |
| 5 | <ul style="list-style-type: none"> • Key On • Reconnect back-up alarm/light to main harness • Enable back-up alarm/light • Backprobe using a voltmeter between 87/PUR and 17/PUR at the Curtis 1234 controller connection • Is there battery voltage applied? | | Repair or Replace Wire Harness | Replace Curtis 1234 Controller |

Terms:

LCD = Liquid Crystal Display

Backprobe = To insert voltmeter probe(s) into the back of a connector to contact a terminal(s) while the circuit operates or should be operating.

VDC = DC Voltage

TROUBLESHOOTING

Onboard Battery Charging ON

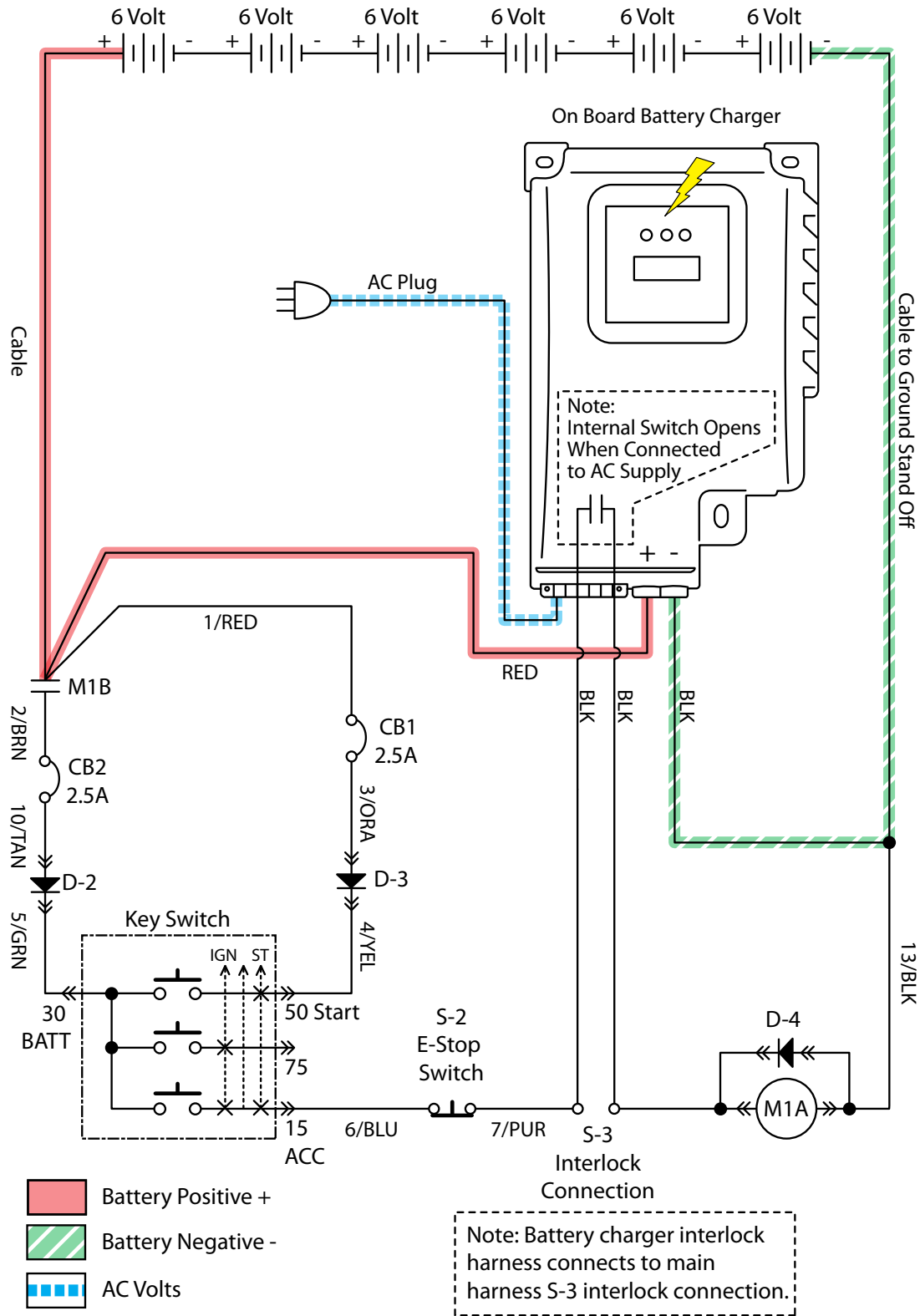

OBC001

Batteries Failed to Charge

| STEP | ACTION | VALUE(S) | YES | NO |
|------|---|----------|---|--|
| 1 | <ul style="list-style-type: none"> • Key Off • Is there a pertinent fault displayed on the onboard charger (bat, E01, E02, E03, SCt, or Srt)? | | See "Onboard Battery Charger Faults" Section of This Manual | Go to Step #2 |
| 2 | <ul style="list-style-type: none"> • Key Off • Check AC power supply • Is the rated AC supply voltage present? | | Go to Step #3 | Check AC Supply Circuit Protection |
| 3 | <ul style="list-style-type: none"> • Key Off • Disconnect batteries • Unplug charger from AC supply • Check fuse located on bottom side of charger • Is the fuse blown? | | Replace Fuse and Test Charger Operation | Go to Step #4 |
| 4 | <ul style="list-style-type: none"> • Key Off • Inspect battery and charger cables for damage, corrosion, contamination or terminal problems • Do any of the above conditions exist? | | Repair or Replace Battery and/or Charger Cables | Go to Step #5 |
| 5 | <ul style="list-style-type: none"> • Skip this step for sealed, AGM, or gel batteries • Key Off • Disconnect batteries • Check water level of all battery cells • Are the lead plates submerged? | | Go to Step #6 | Add Distilled Water Until Lead Plates are Covered. |
| 6 | <ul style="list-style-type: none"> • Key Off • Load test all batteries (AGM, Gel, Lead-Acid) • -or- • Test specific gravity of each cell using a hydrometer or refractometer (Lead-Acid) • Do the batteries pass a load test or are all battery cells within 0.050 (50 points) specific gravity of each other? | | Replace Battery Charger | Replace Battery or Batteries |

Terms:

AC = Alternating Current

AGM = Absorbed Glass Mat

Specific Gravity = Relative density of a substance compared to water (1.000 specific gravity)

Off Board Battery Charging ON

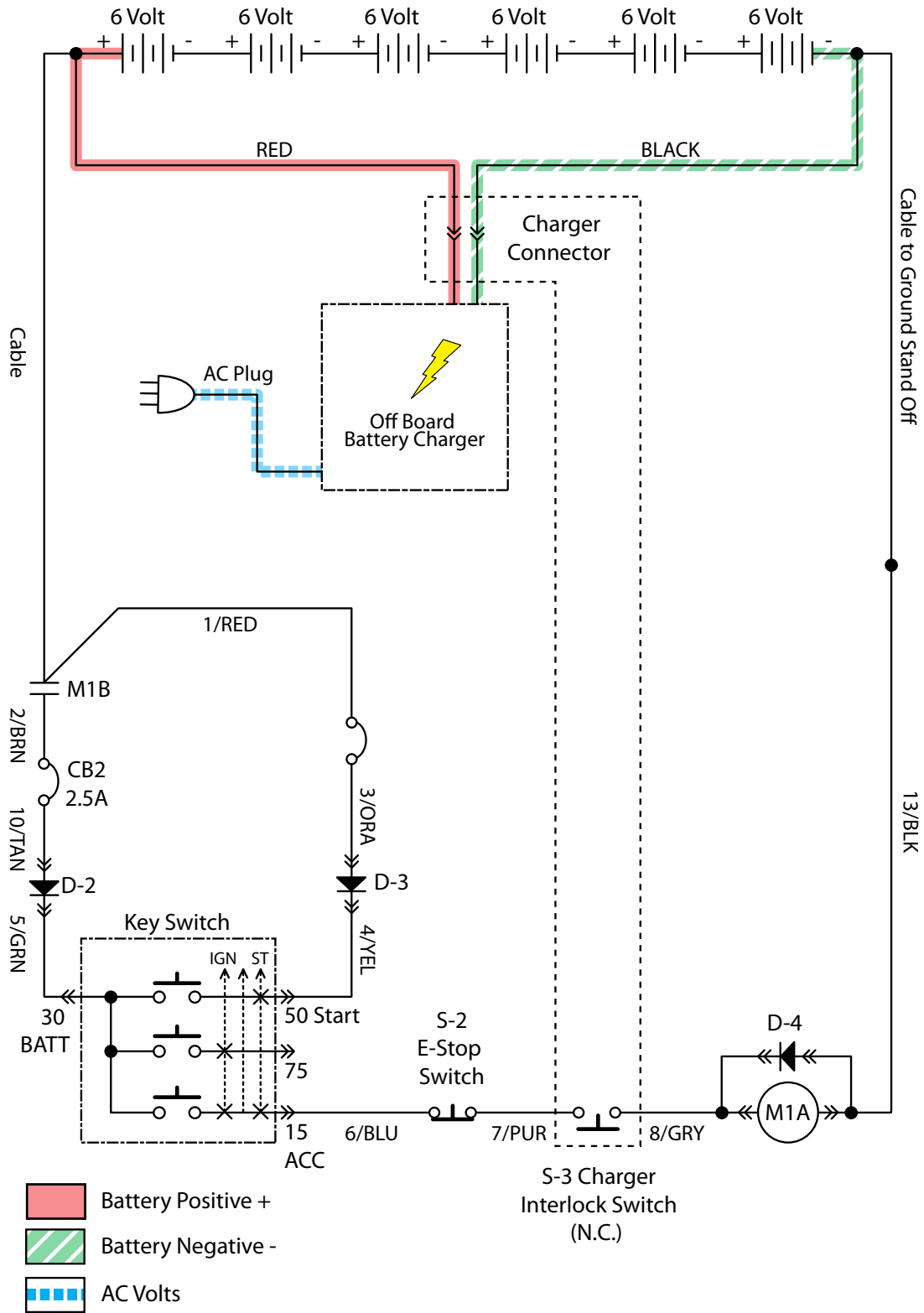

OBC002

Batteries Failed to Charge

| STEP | ACTION | VALUE(S) | YES | NO |
|------|--|----------|--|--|
| 1 | <ul style="list-style-type: none"> • Key Off • Check AC power supply • Is the rated AC supply voltage present? | | Go to Step #2 | Check AC Supply Circuit Protection |
| 2 | <ul style="list-style-type: none"> • Key Off • Disconnect batteries • Unplug charger from AC supply • Check charger fuse or circuit breaker (if equipped) • Is a fuse blown or circuit breaker tripped? | | Replace Fuse or Reset Circuit Breaker and Test Charger Operation | Go to Step #3 |
| 3 | <ul style="list-style-type: none"> • Key Off • Inspect battery and charger cables for damage, corrosion, contamination or terminal problems • Do any of the above conditions exist? | | Repair or Replace Battery and/or Charger Cables | Go to Step #4 |
| 4 | <ul style="list-style-type: none"> • Skip this step for sealed, AGM, or gel batteries • Key Off • Disconnect batteries • Check water level of all battery cells • Are the lead plates submerged? | | Go to Step #5 | Add Distilled Water Until Lead Plates are Covered. |
| 5 | <ul style="list-style-type: none"> • Key Off • Load test all batteries (AGM, Gel, Lead-Acid) • -or- • Test specific gravity of each cell using a hydrometer or refractometer ((Lead-Acid) • Do the batteries pass a load test or are all battery cells within 0.050 (50 points) specific gravity of each other? | | Replace Battery Charger | Replace Battery or Batteries |

Terms:

AC = Alternating Current

AGM = Absorbed Glass Mat

Specific Gravity = Relative density of a substance compared to water (water = 1.000 specific gravity)

TROUBLESHOOTING

Parking Brake, Electromagnetic (Released)

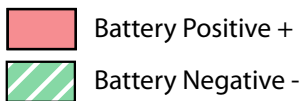
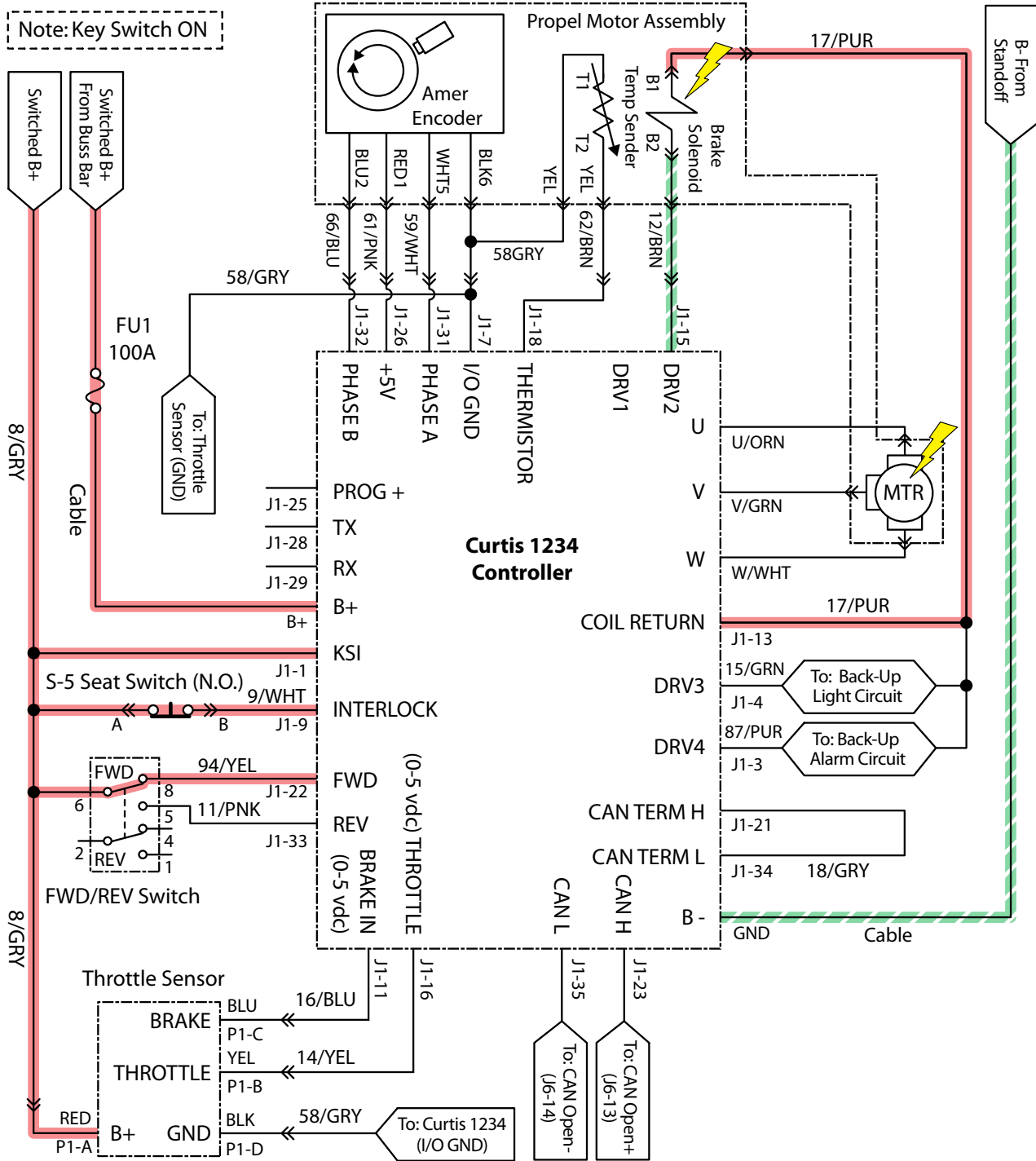

Operational Matrix:

Electro-Magnetic Brake

| Enabled (Applied) | Disabled (Released) |
|---|---|
| <ul style="list-style-type: none"> • Key Off • E-Stop Switch Open (Up) • Neutral (1-2 Second Delay) • Seat Switch Open • Curtis 1234 Fault | <ul style="list-style-type: none"> • Key ON • E-Stop Switch Closed (Down) • Throttle Command • Seat Switch Closed |

PMC012

Parking Brake Failed to Release/Apply

| STEP | ACTION | VALUE(S) | YES | NO |
|------|--|--|---|---|
| 1 | <ul style="list-style-type: none"> Key On Is there a pertinent LCD warning or fault message displayed? | | See "LCD Warnings" or "LCD Faults" Sections | Go to Step #2 |
| 2 | <ul style="list-style-type: none"> Key On See "Curtis 1234 Controller Diagnostics" section Is there a pertinent Curtis 1234 fault displayed? | | Correct Fault Condition | Go to Step #3 |
| 3 | <ul style="list-style-type: none"> Key Off See "Propel Diagnostic Mode" Is P1:Curtis Online? Does P2:Throttle input voltage (0-5 vdc) change proportionally with throttle pedal movement? Does P3:Brake pedal input turn On/Off with brake pedal activation? Does P4:Direction input correspond with Fwd/Rev rocker switch position? Does P5:Speed input from drive assembly encoder (speed, direction, position sensor) read "0000.0 Mph?" Does P8:Propel motor current read "0000.0 Amps?" Is the answer "Yes" to all of the above? | | Go to Step #4 | Correct Faulty Input Condition |
| 4 | <ul style="list-style-type: none"> Key Off See TESTING PARKING BRAKE, ELECTROMAGNETIC in the SERVICE section of this manual Does the brake pass the testing? | See TESTING PARKING BRAKE, ELECTROMAGNETIC | Go to Step #5 | Repair or Replace Parking Brake Assembly |
| 5 | <ul style="list-style-type: none"> Reconnect parking brake assembly to propel harness Key On Disable(Release) brake Test voltage applied to the parking brake as shown on the electrical schematic Are the electrical circuits operating as shown on the electrical schematic? | | Go Back to Step #1 | Identify Voltage Drop Location and Repair or Replace Necessary Components |

Terms:

LCD = Liquid Crystal Display

TROUBLESHOOTING

Detergent Metering ON (Option)

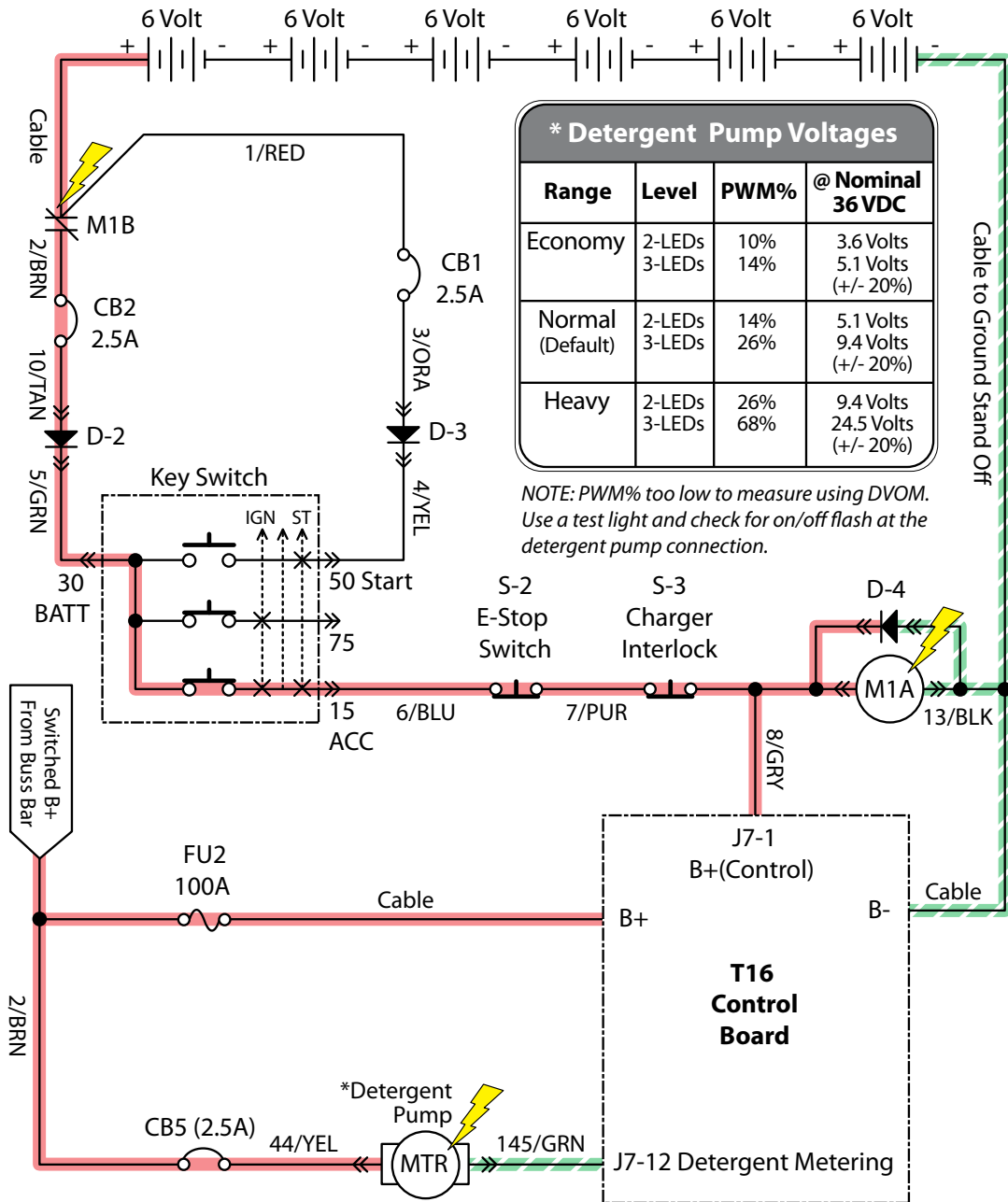

| Operational Matrix: | | |
|---------------------|---|--|
| | Enabled | Disabled |
| Detergent Metering | <ul style="list-style-type: none"> 1-STEP Scrub ON Solution Control ON (Conventional Only) 2 or 3 Solution LEDs ON Fwd/Rev Propel | <ul style="list-style-type: none"> 1-STEP Scrub OFF Solution Control OFF 0 or 1 Solution LEDs ON Neutral-Ready State Recovery Tank Full Solution Tank Empty Very Low Batt Voltage Load Current Fault |

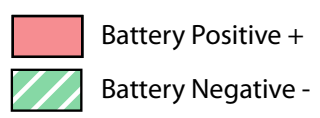

DMP001

Detergent Metering Failed to Turn ON

| STEP | ACTION | VALUE(S) | YES | NO |
|------|---|----------|---|---|
| 1 | <ul style="list-style-type: none"> • Key On • Enable detergent metering subsystem • Is there a pertinent LCD warning or fault message displayed? | | See "LCD Warnings" or "LCD Faults" Sections | Go to Step #2 |
| 2 | <ul style="list-style-type: none"> • Key Off • Firmly press circuit breaker #5 to reset • Was circuit breaker #5 tripped? | | Reset Circuit Breaker and Test Detergent Metering Operation | Go to Step #3 |
| 3 | <ul style="list-style-type: none"> • Key Off • See "Self-Test Mode" • Does the Self-Test display output circuit J7-12 as open or shorted? | | Correct Open or Short Circuit Condition | Go to Step #4 |
| 4 | <ul style="list-style-type: none"> • Key Off • Disconnect detergent metering pump from main harness • Apply battery voltage to detergent metering pump using fuse-protected jumper leads • Does the detergent metering pump dispense detergent? | | Go to Step #5 | Replace Detergent Metering Pump |
| 5 | <ul style="list-style-type: none"> • Key Off • Reconnect detergent metering pump to main harness • Key On • Enable detergent metering subsystem • Test voltage applied to the detergent metering subsystem as shown on the electrical schematic • Are the electrical circuits operating as shown on the electrical schematic? | | Go Back to Step #1 | Identify Voltage Drop Location and Repair or Replace Necessary Components |

Terms:

LCD = Liquid Crystal Display

J7-12 = T16 Control Board Connector #7, Pin #12

TROUBLESHOOTING

Extended Scrub ON (Option)

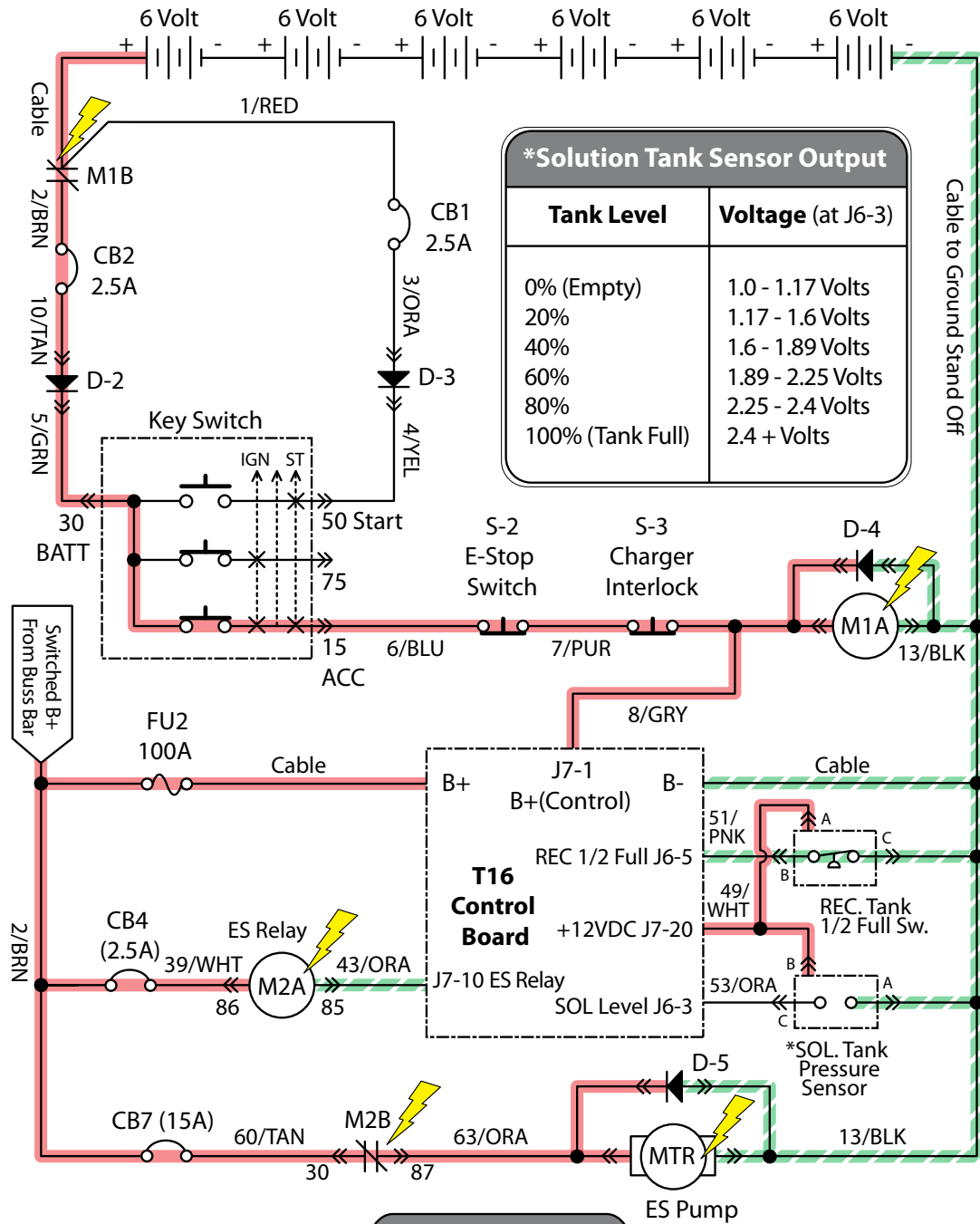

***Solution Tank Sensor Output**

| Tank Level | Voltage (at J6-3) |
|------------------|-------------------|
| 0% (Empty) | 1.0 - 1.17 Volts |
| 20% | 1.17 - 1.6 Volts |
| 40% | 1.6 - 1.89 Volts |
| 60% | 1.89 - 2.25 Volts |
| 80% | 2.25 - 2.4 Volts |
| 100% (Tank Full) | 2.4 + Volts |

Operational Matrix:

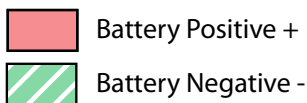

| | Enabled | Disabled |
|-----------------------|--|--|
| Extended Scrub | <ul style="list-style-type: none"> • 1-STEP Scrub ON • Solution Control ON • ES Button ON • Recovery Tank 1/2 Full | <ul style="list-style-type: none"> • 1-STEP Scrub OFF • Solution Control OFF • ES Button OFF • Solution Tank Full • Recovery Tank Full • Very Low Batt Voltage • Load Current Fault |

ESC001

Extended Scrub Failed to Turn ON

| STEP | ACTION | VALUE(S) | YES | NO |
|------|---|----------|--|---|
| 1 | <ul style="list-style-type: none"> • Key On • Enable ES (Extended Scrub) subsystem • Is there a pertinent LCD warning or fault message displayed? | | See "LCD Warnings" or "LCD Faults" Sections | Go to Step #2 |
| 2 | <ul style="list-style-type: none"> • Key Off • Firmly press circuit breaker #4 to reset • Firmly press circuit breaker #7 to reset • Was a circuit breaker tripped? | | Reset Circuit Breaker(s) and Test ES Subsystem Operation | Go to Step #3 |
| 3 | <ul style="list-style-type: none"> • Key Off • See "Manual Mode" section of this manual • Activate the ES pump in manual mode • Does the ES pump turn On? | | Go to Step #6 | Go to Step #4 |
| 4 | <ul style="list-style-type: none"> • Key Off • See "Self-Test Mode" section of this manual • Does the Self-Test display output circuit J7-10 as open or shorted? | | Correct Open or Short Circuit Condition | Go to Step #5 |
| 5 | <ul style="list-style-type: none"> • Key Off • Disconnect ES pump from main harness • Apply battery voltage to ES pump using fuse-protected jumper leads • Does the ES pump turn On and transfer solution from the recovery tank to the solution tank? | | Go to Step #6 | Replace ES Pump |
| 6 | <ul style="list-style-type: none"> • Key Off • Reconnect ES pump to main harness • Key On • Enable ES subsystem • Test voltage applied to the ES subsystem as shown on the electrical schematic • Are the electrical circuits operating as shown on the electrical schematic? | | Go Back to Step #1 | Identify Voltage Drop Location and Repair or Replace Necessary Components |

Terms:

ES = Extended Scrub

LCD = Liquid Crystal Display

J7-10 = T16 Control Board Connector #7, Pin #10

TROUBLESHOOTING

Lighting ON

Note: Key Switch ON

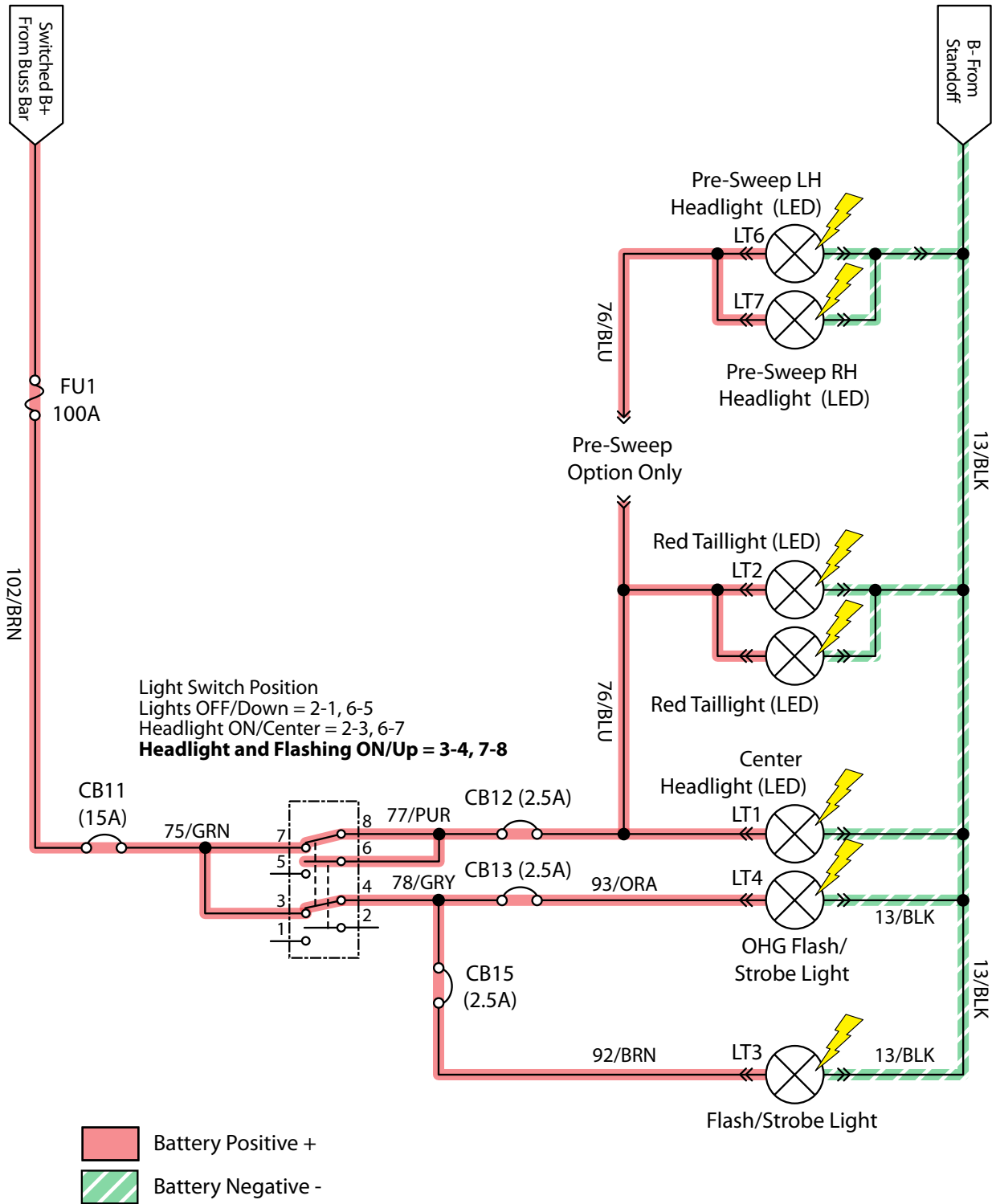

ELC001

Lighting Failed to Turn ON

| STEP | ACTION | VALUE(S) | YES | NO |
|----------|---|----------|-----------------------------------|---|
| 1 | <ul style="list-style-type: none"> • Key On • Light switch On • Firmly press circuit breaker #11 to reset • Is circuit breaker #11 tripped? | | Reset and Test Lighting Operation | Go to Step #2 |
| 2 | <ul style="list-style-type: none"> • Key On • Light switch On • Firmly press circuit breaker #12 (Option) to reset • Is circuit breaker #12 tripped? | | Reset and Test Lighting Operation | Go to Step #3 |
| 3 | <ul style="list-style-type: none"> • Key On • Light switch On • Firmly press circuit breaker #13 (Option) to reset • Is circuit breaker #13 tripped? | | Reset and Test Lighting Operation | Go to Step #4 |
| 4 | <ul style="list-style-type: none"> • Key On • Light switch On • Firmly press circuit breaker #15 (Option) to reset • Is circuit breaker #15 tripped? | | Reset and Test Lighting Operation | Go to Step #5 |
| 5 | <ul style="list-style-type: none"> • Key On • Light switch On • Test voltage applied to the lighting subsystem as shown on the electrical schematic • Are the electrical circuits operating as shown on the electrical schematic? | | Go Back to Step #1 | Identify Voltage Drop Location and Repair or Replace Necessary Components |

TROUBLESHOOTING

Main Scrub Brushes ON

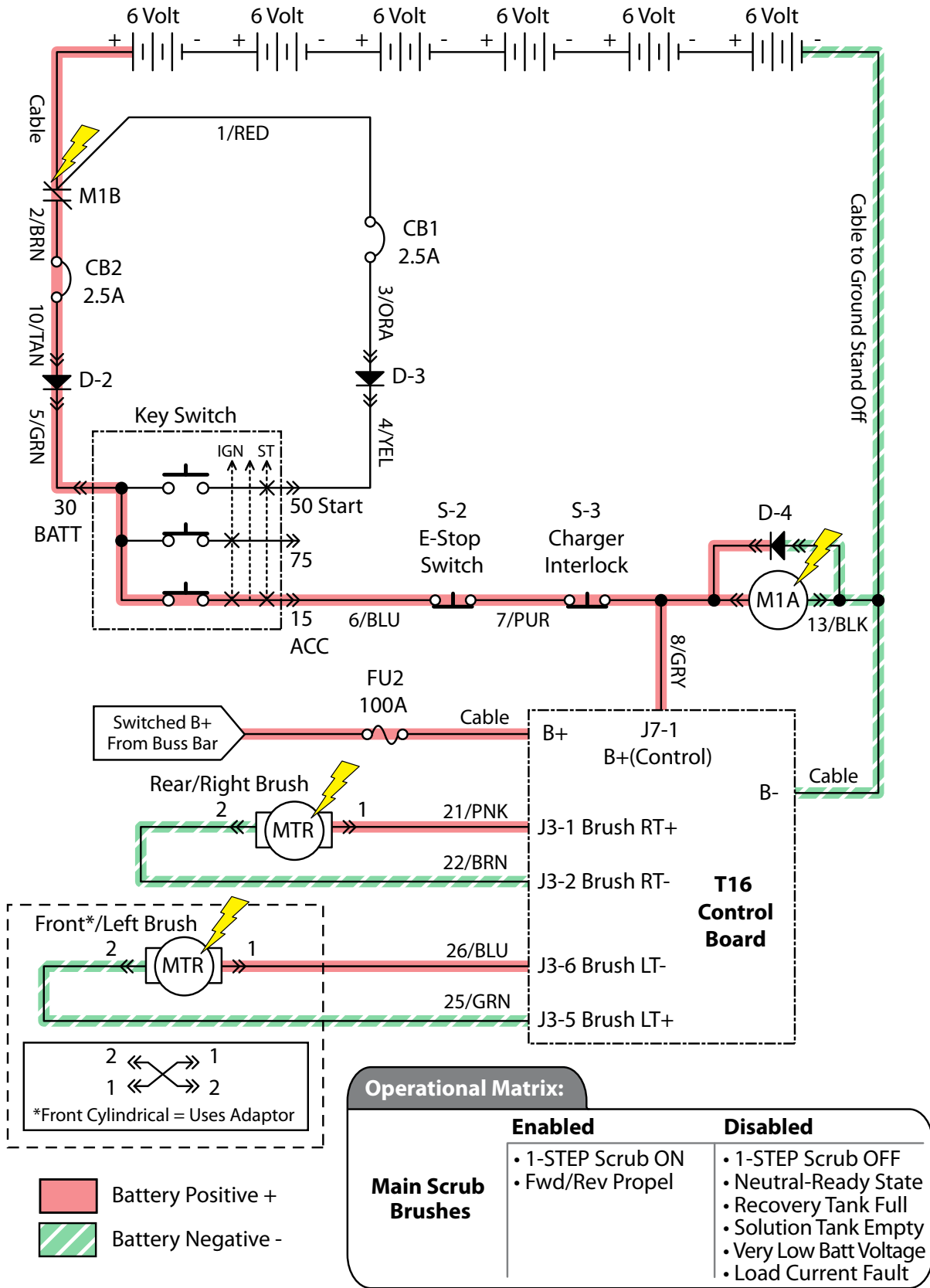

MSC001

Main Scrub Brushes Failed to Turn ON

| STEP | ACTION | VALUE(S) | YES | NO |
|------|---|-------------------------------------|---|---|
| 1 | <ul style="list-style-type: none"> • Key On • Enable main scrub brushes subsystem • Is there a pertinent LCD warning or fault message displayed? | | See "LCD Warnings" or "LCD Faults" Sections | Go to Step #2 |
| 2 | <ul style="list-style-type: none"> • Key Off • See "Manual Mode" section of this manual • Activate the main scrub brushes in manual mode • Do the scrub brushes turn On? | | Go to Step #6 | Go to Step #3 |
| 3 | <ul style="list-style-type: none"> • Key Off • See "Self-Test Mode" • Does the Self-Test display output circuits J3-1, J3-2, J3-5, or J3-6 as open or shorted? | | Correct Open or Short Circuit Condition | Go to Step #4 |
| 4 | <ul style="list-style-type: none"> • Proceed to Step #5 for disk scrub head models • Key Off • Remove cylindrical brushes from scrub head • Check for worn out brushes (see maintenance section) • Check brushes for entangled debris • Check brush idler plugs and bearings for excessive wear, damage, seizure, etc. • Check main brush drive belts for excessive wear, damage, etc • Do any of the above conditions exist? | | Repair or Replace Necessary Cylindrical Scrub Head Components | Go to Step #5 |
| 5 | <ul style="list-style-type: none"> • Key Off • See TESTING MAIN SCRUB BRUSH MOTORS in the SERVICE section of this manual • Do the scrub brush motors pass the testing? | See TESTING MAIN SCRUB BRUSH MOTORS | Go to Step #6 | Repair or Replace Main Scrub Brush Motors |
| 6 | <ul style="list-style-type: none"> • Key Off • Reconnect main scrub brush motors to main harness • Key On • Enable main scrub brush motors • Test voltage applied to the main scrub brush motor subsystem as shown on the electrical schematic • Are the electrical circuits operating as shown on the electrical schematic? | | Go Back to Step #1 | Identify Voltage Drop Location and Repair or Replace Necessary Components |

Terms:

LCD = Liquid Crystal Display

J3-1 = T16 Control Board Connector #3, Pin #1

J3-2 = T16 Control Board Connector #3, Pin #2

J3-5 = T16 Control Board Connector #3, Pin #5

J3-6 = T16 Control Board Connector #3, Pin #6

TROUBLESHOOTING

Power-Up ON

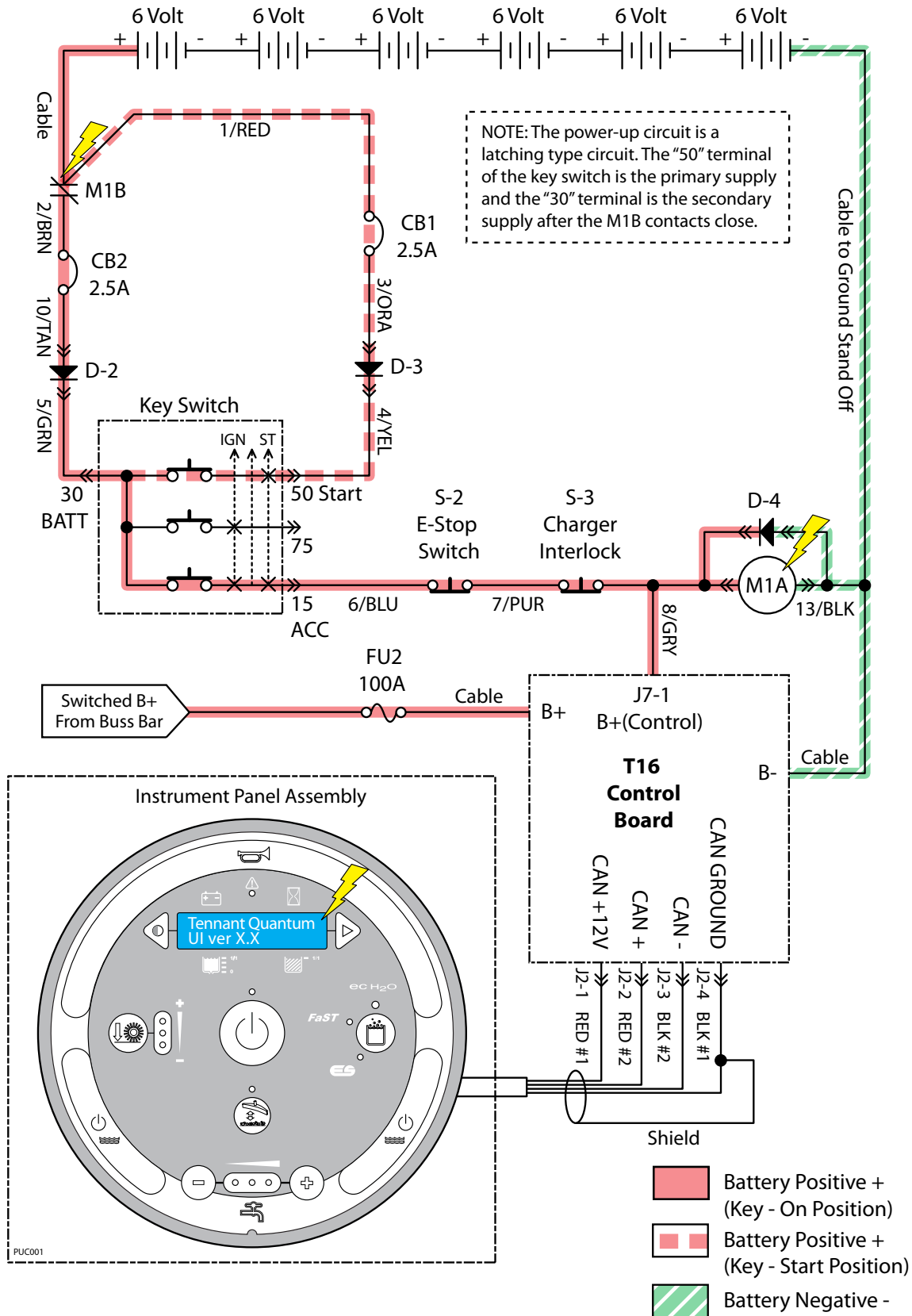

Machine Failed to Power Up

| STEP | ACTION | VALUE(S) | YES | NO |
|------|--|----------|---|---|
| 1 | <ul style="list-style-type: none"> • Key in Start Position • Test the total battery voltage using a voltmeter • Is the total battery voltage greater than 30 VDC? | | Go to Step #2 | Recharge Batteries and Test Power-Up Circuit Operation |
| 2 | <ul style="list-style-type: none"> • Key Off • Firmly press circuit breaker #2 to reset • Is circuit breaker #2 tripped? | | Reset and Test Power-Up Circuit Operation | Go to Step #3 |
| 3 | <ul style="list-style-type: none"> • Key Off • Firmly press circuit breaker #1 to reset • Is circuit breaker #1 tripped? | | Reset and Test Power-Up Circuit Operation | Go to Step #4 |
| 4 | <ul style="list-style-type: none"> • Key Off • Inspect fuse #2 (100 Amp) • Is fuse #2 blown? | | Identify Cause of Circuit Overload and Replace Fuse | Go to Step #5 |
| 5 | <ul style="list-style-type: none"> • Cycle key switch from Start to On Position • Test voltage applied to the power-up subsystem as shown on the electrical schematic • Are the electrical circuits operating as shown on the electrical schematic? | | Go Back to Step #1 | Identify Voltage Drop Location and Repair or Replace Necessary Components |

Terms:
VDC = DC Voltage

TROUBLESHOOTING

Pre-Sweep Brushes ON (Option)

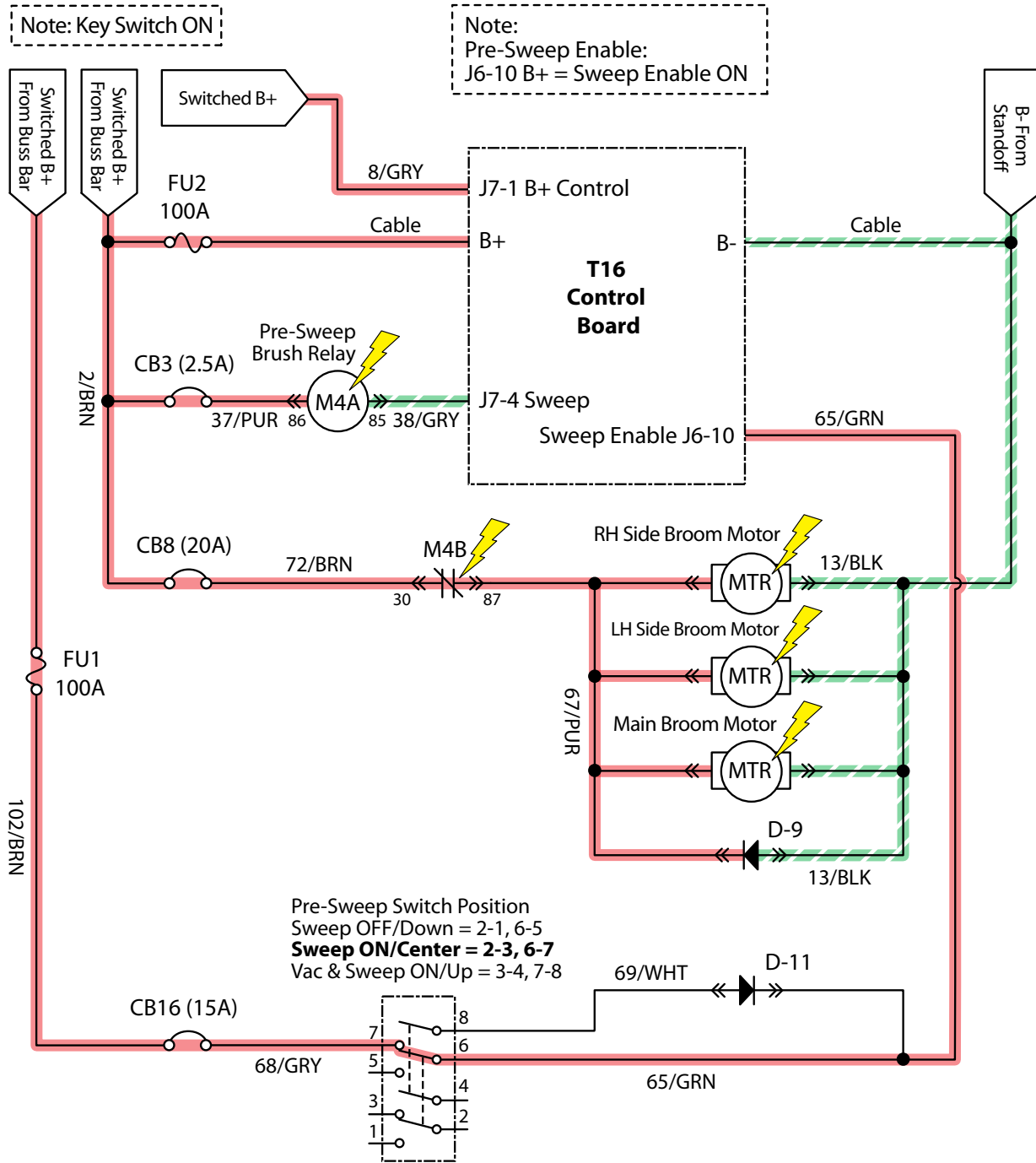

Operational Matrix:

- Battery Positive +
- Battery Negative -

Pre-Sweep Brushes

Enabled

- Pre-Sweep Switch ON
- Fwd/Rev Propel

Disabled

- Pre-Sweep Switch OFF
- Neutral-Ready State
- Very Low Battery Voltage
- Load Current Fault

PS8001

Pre-Sweep Brushes Failed to Turn ON (Option)

| STEP | ACTION | VALUE(S) | YES | NO |
|------|---|----------|---|---|
| 1 | <ul style="list-style-type: none"> Key On Enable Pre-Sweep brushes subsystem Is there a pertinent LCD warning or fault message displayed? | | See "LCD Warnings" or "LCD Faults" Sections | Go to Step #2 |
| 2 | <ul style="list-style-type: none"> Key Off See "Manual Mode" section of this manual Activate the Pre-Sweep brushes in manual mode Do the Pre-Sweep brushes turn On? | | Go to Step #8 | Go to Step #3 |
| 3 | <ul style="list-style-type: none"> Key Off See "Self-Test Mode" Does the Self-Test display output circuit J7-4 as open or shorted? | | Correct Open or Short Circuit Condition | Go to Step #4 |
| 4 | <ul style="list-style-type: none"> Key Off Firmly press circuit breaker #3 to reset Is circuit breaker #3 tripped? | | Reset and Test Pre-Sweep Brushes Operation | Go to Step #5 |
| 5 | <ul style="list-style-type: none"> Key Off Firmly press circuit breaker #8 to reset Is circuit breaker #8 tripped? | | Reset and Test Pre-Sweep Brushes Operation | Go to Step #6 |
| 6 | <ul style="list-style-type: none"> Key Off Firmly press circuit breaker #16 to reset Is circuit breaker #16 tripped? | | Reset and Test Pre-Sweep Brushes Operation | Go to Step #7 |
| 7 | <ul style="list-style-type: none"> Key Off See TESTING MAIN SWEEP BROOM MOTOR in the SERVICE section of this manual See TESTING SIDE BRUSH MOTOR(S) (Pre-Sweep) in the SERVICE section of this manual Does each Pre-Sweep brush motor pass the testing? | | Go to Step #8 | Repair or Replace Pre-Sweep Brush Motor(s) |
| 8 | <ul style="list-style-type: none"> Key On Test voltage applied to the Pre-Sweep subsystem as shown on the electrical schematic Are the electrical circuits operating as shown on the electrical schematic? | | Go Back to Step #1 | Identify Voltage Drop Location and Repair or Replace Necessary Components |

Terms:

LCD = Liquid Crystal Display



J7-4 = T16 Control Board Connector #7, Pin #4

TROUBLESHOOTING

Pre-Sweep Brushes Down, OFF (Option)

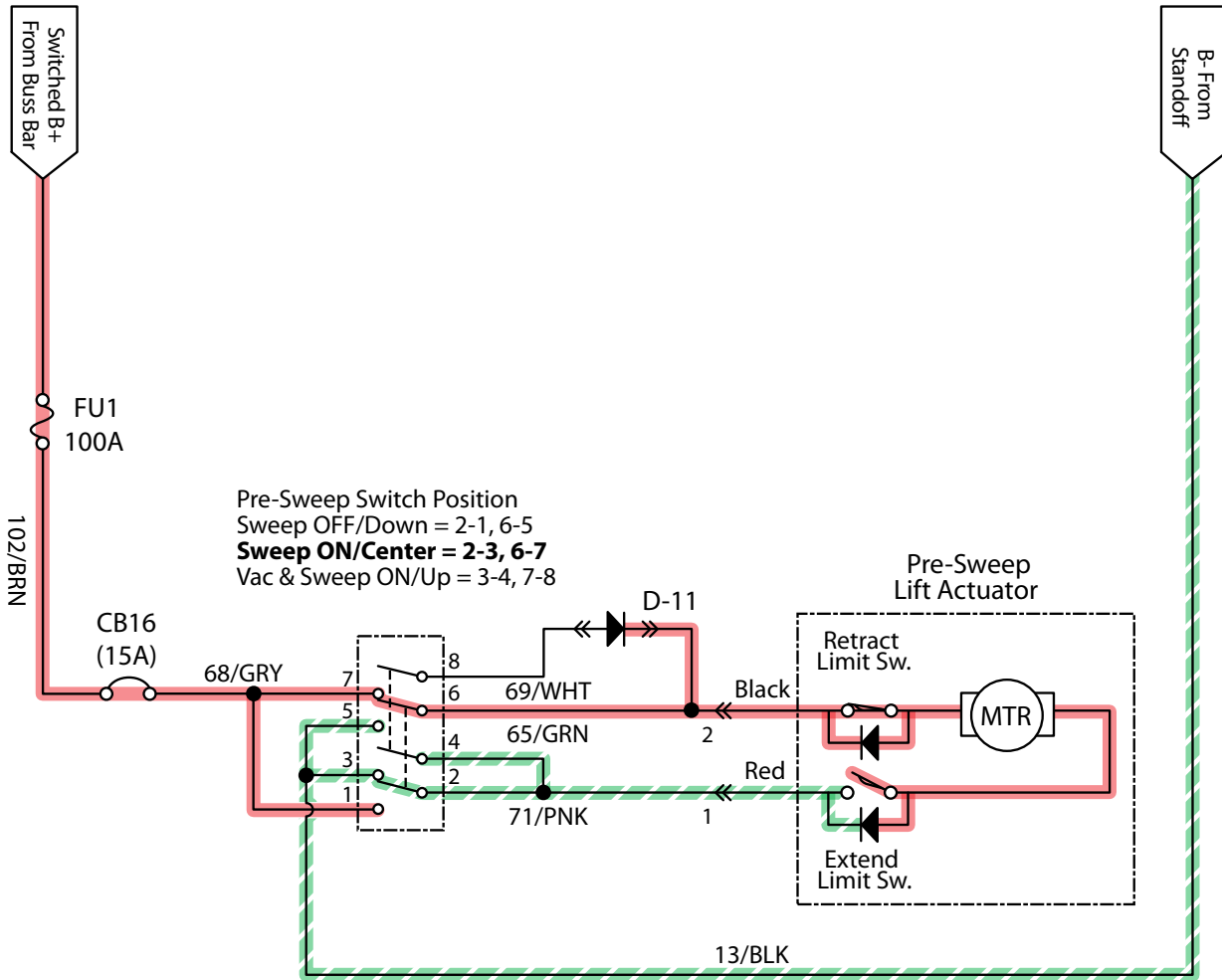
Note: Key Switch ON



 Battery Positive +
 Battery Negative -

Operational Matrix:

| | Enabled | Disabled |
|-------------------------------|-----------------------|------------------------|
| Pre-Sweep Brushes Down | • Pre-Sweep Switch ON | • Pre-Sweep Switch OFF |

PSL001

Pre-Sweep Brushes Failed to Lower (Option)



| STEP | ACTION | VALUE(S) | YES | NO |
|----------|---|-------------------------------------|---|---|
| 1 | <ul style="list-style-type: none"> • Key On • Pre-Sweep switch On • Firmly press circuit breaker #16 to reset • Is circuit breaker #16 tripped? | | Reset and Test Pre-Sweep Lift Operation | Go to Step #2 |
| 2 | <ul style="list-style-type: none"> • Key Off • See TESTING PRE-SWEEP LIFT ACTUATOR in the SERVICE section of this manual • Does the Pre-Sweep lift actuator pass the testing? | See TESTING PRE-SWEEP LIFT ACTUATOR | Go to Step #3 | Replace Pre-Sweep Lift Actuator |
| 3 | <ul style="list-style-type: none"> • Key On • Pre-Sweep switch On • Test voltage applied to the Pre-Sweep lift subsystem as shown on the electrical schematic • Are the electrical circuits operating as shown on the electrical schematic? | | Go Back to Step #1 | Identify Voltage Drop Location and Repair or Replace Necessary Components |

TROUBLESHOOTING

Pre-Sweep Brushes Up, OFF (Option)

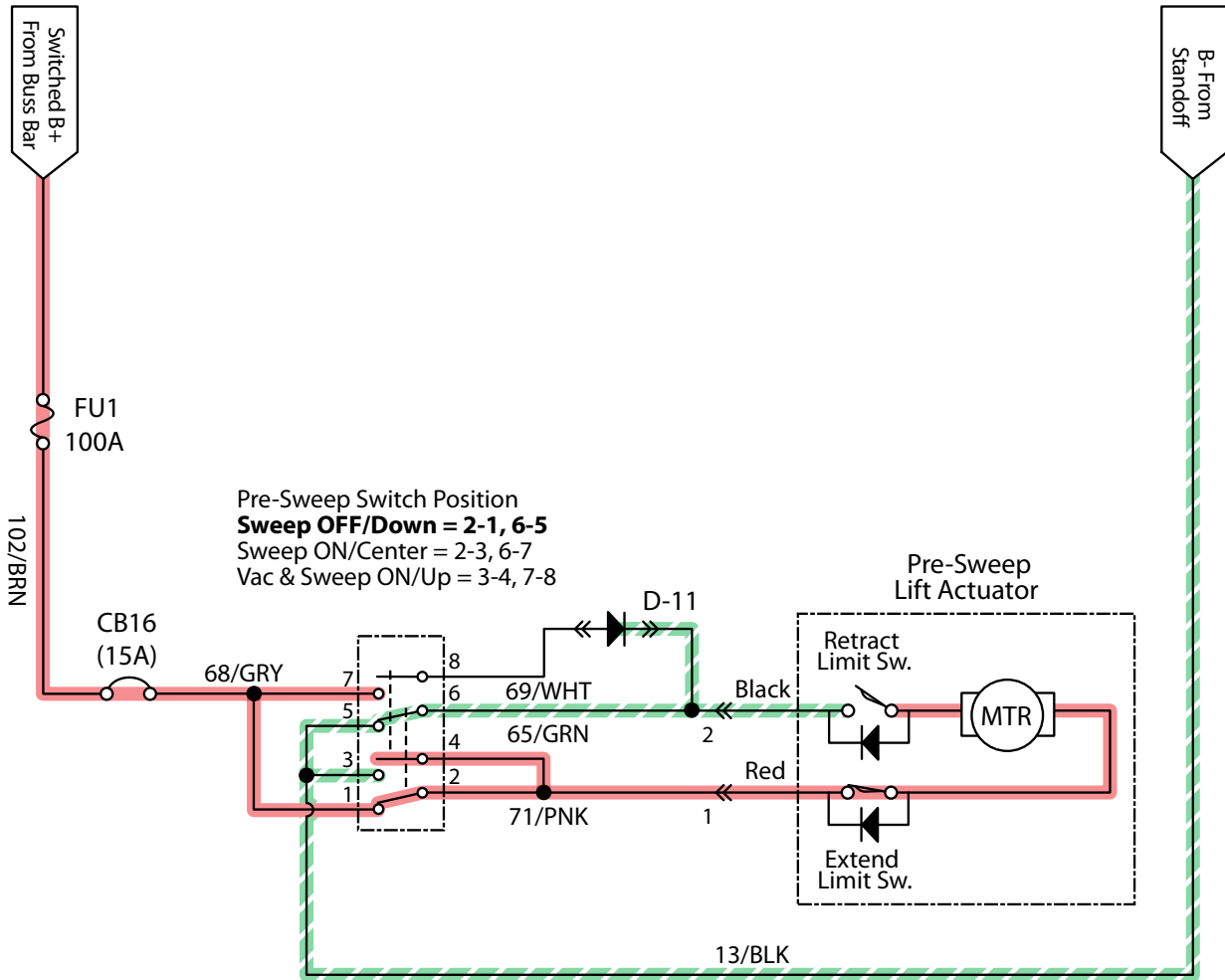
Note: Key Switch ON



 Battery Positive +
 Battery Negative -

Operational Matrix:

| | Enabled | Disabled |
|----------------------|------------------------|-----------------------|
| Pre-Sweep Brushes Up | • Pre-Sweep Switch OFF | • Pre-Sweep Switch ON |

PSL002

Pre-Sweep Brushes Failed to Raise (Option)

| STEP | ACTION | VALUE(S) | YES | NO |
|----------|---|-------------------------------------|---|---|
| 1 | <ul style="list-style-type: none"> • Key On • Pre-Sweep switch On • Firmly press circuit breaker #16 to reset • Is circuit breaker #16 tripped? | | Reset and Test Pre-Sweep Lift Operation | Go to Step #2 |
| 2 | <ul style="list-style-type: none"> • Key Off • See TESTING PRE-SWEEP LIFT ACTUATOR in the SERVICE section of this manual • Does the Pre-Sweep lift actuator pass the testing? | See TESTING PRE-SWEEP LIFT ACTUATOR | Go to Step #3 | Replace Pre-Sweep Lift Actuator |
| 3 | <ul style="list-style-type: none"> • Key On • Pre-Sweep switch On • Test voltage applied to the Pre-Sweep lift subsystem as shown on the electrical schematic • Are the electrical circuits operating as shown on the electrical schematic? | | Go Back to Step #1 | Identify Voltage Drop Location and Repair or Replace Necessary Components |

TROUBLESHOOTING

Propel Subsystem, Forward

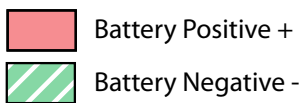
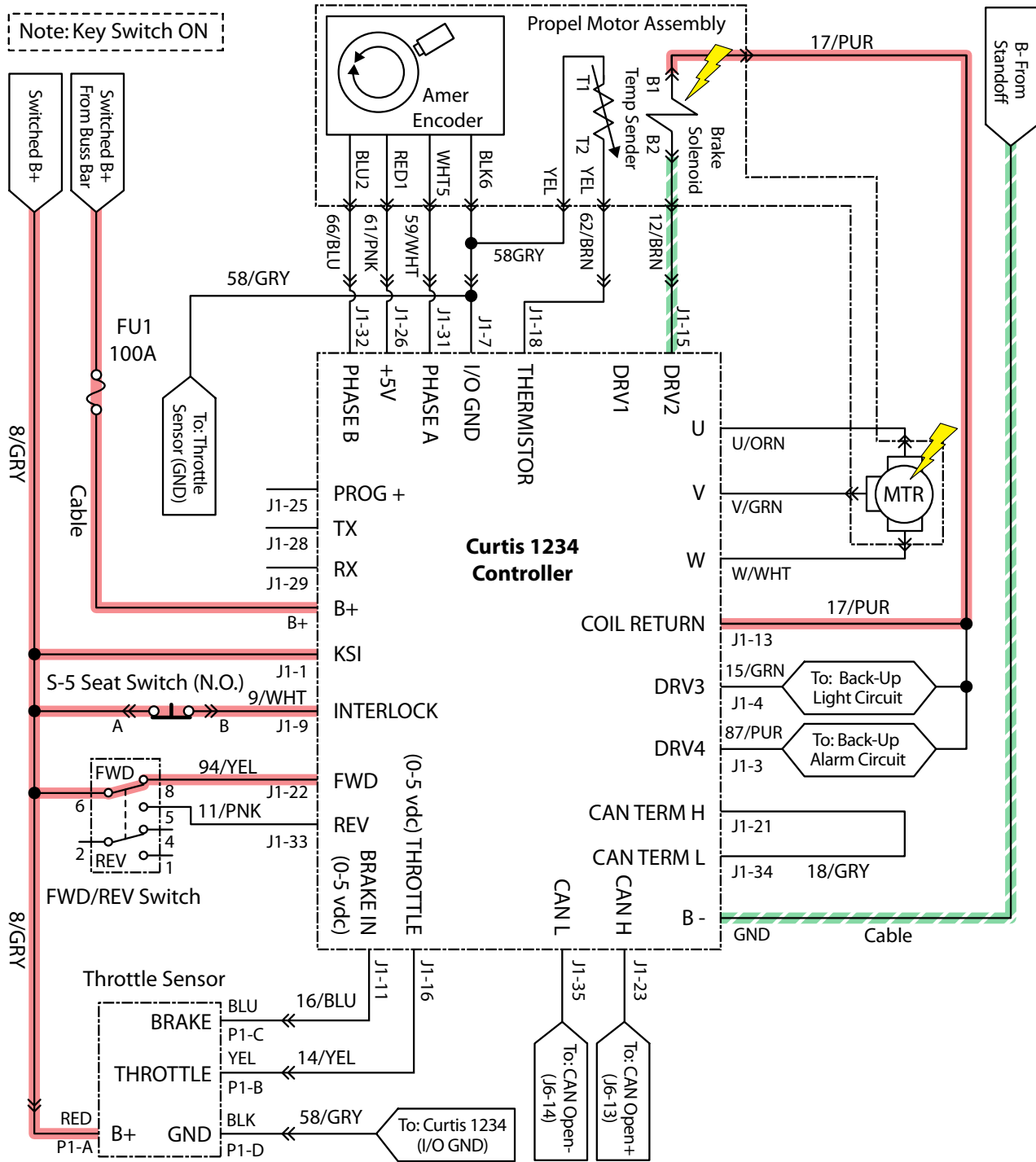

Operational Matrix:

| | Enabled | Disabled |
|---------------|---|---|
| Propel | <ul style="list-style-type: none"> • Seat Switch Closed • Foot Throttle Command • Fwd/Rev Switch Input | <ul style="list-style-type: none"> • Seat Switch Open • Neutral-Ready State Command • Brake Command • Curtis 1234 Fault |

PMC001

Machine Failed to Propel

| STEP | ACTION | VALUE(S) | YES | NO |
|----------|---|----------|-------------------------|---|
| 1 | <ul style="list-style-type: none"> • Key On • See "Curtis 1234 Controller Diagnostics" section of this manual • Does a Curtis 1234 controller fault condition exist? | | Correct Fault Condition | Go to Step #2 |
| 2 | <ul style="list-style-type: none"> • Key Off • See "Propel Diagnostic Mode" • Is P1:Curtis Online? • Does P2: Throttle input voltage (0-5 vdc) change proportionally with throttle pedal movement? • Does P3 :Brake pedal input turn On/Off with brake pedal activation? • Does P4: Direction input correspond with Fwd/Rev rocker switch position? • Does P5:Speed input from drive assembly encoder (speed, direction, position sensor) read "0000.0 Mph?" • Does P8:Propel motor current read "0000.0 Amps?" • Is the answer "Yes" to all of the above? | | Go to Step #3 | Correct Faulty Input Condition |
| 3 | <ul style="list-style-type: none"> • Key Off • Place machine on jackstands so drive wheel is lifted off the floor • Enable forward propel • Test voltage applied to the propel subsystem as shown on the electrical schematic • Are the electrical circuits operating as shown on the electrical schematic? | | Go Back to Step #1 | Identify Voltage Drop Location and Repair or Replace Necessary Components |

Terms:

LCD = Liquid Crystal Display

VDC = Direct Current Voltage

TROUBLESHOOTING

Rear Squeegee Down, OFF

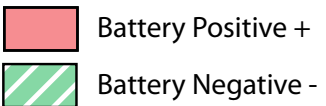
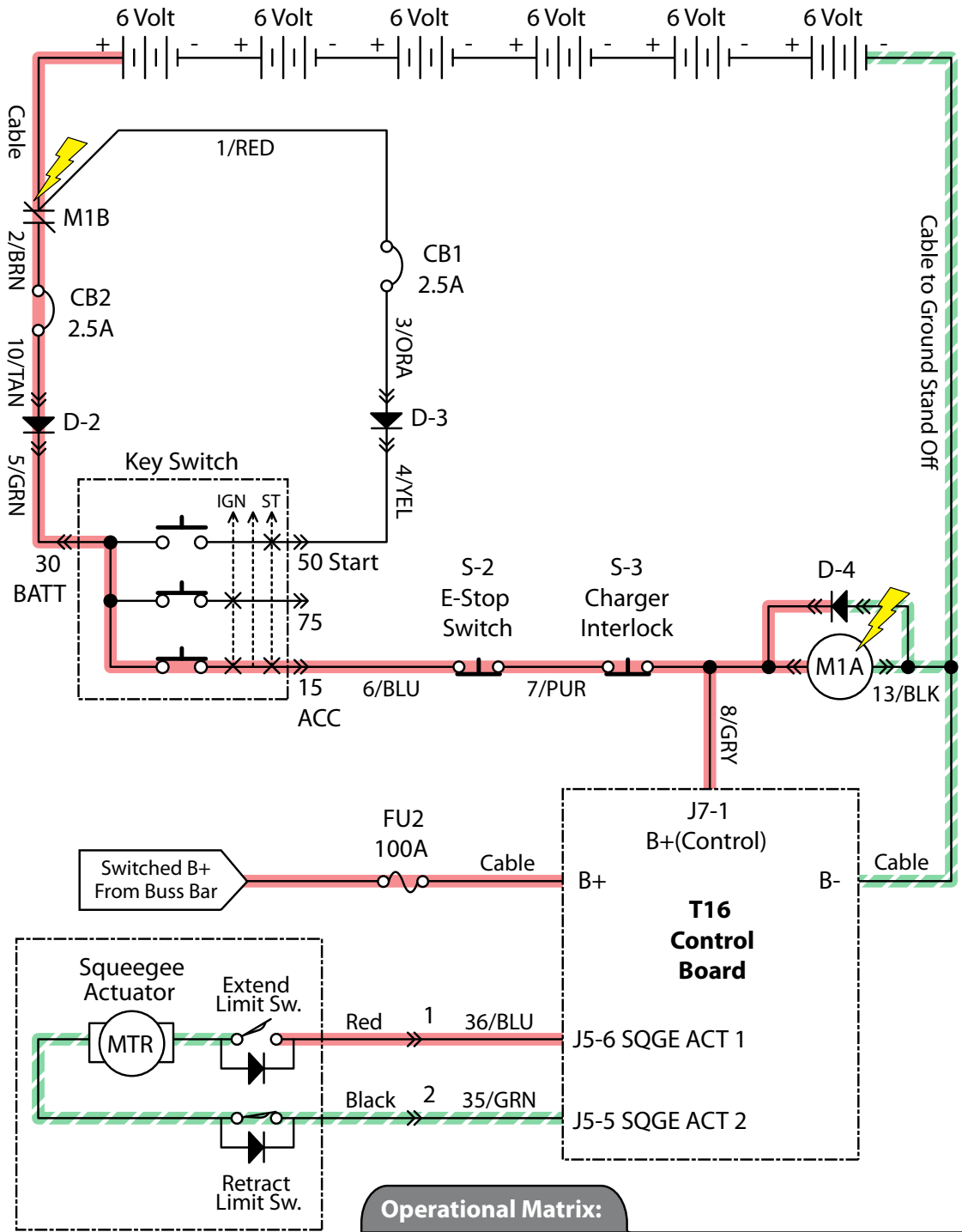

| Operational Matrix: | | |
|---------------------|--|---|
| | Enabled | Disabled |
| Squeegee Down | <ul style="list-style-type: none"> • 1-STEP Scrub ON • Squeegee/Vac ON | <ul style="list-style-type: none"> • 1-STEP Scrub OFF • Squeegee/Vac OFF • Reverse Propel • Recovery Tank Full • Very Low Batt Voltage • Load Current Fault |

RSL001

Rear Squeegee Failed to Raise/Lower

| STEP | ACTION | VALUE(S) | YES | NO |
|----------|---|--|---|---|
| 1 | <ul style="list-style-type: none"> • Key On • Enable rear squeegee down • Is there a pertinent LCD warning or fault message displayed? | | See "LCD Warnings" or "LCD Faults" Sections | Go to Step #2 |
| 2 | <ul style="list-style-type: none"> • Key Off • See "Manual Mode" section of this manual • Activate the rear squeegee in manual mode • Does the rear squeegee raise/lower? | | Go to Step #5 | Go to Step #3 |
| 3 | <ul style="list-style-type: none"> • Key Off • See "Self-Test Mode" • Does the Self-Test display output circuits J5-5 and J5-6 as open or shorted? | | Correct Open or Short Circuit Condition | Go to Step #4 |
| 4 | <ul style="list-style-type: none"> • Key Off • See TESTING REAR SQUEEGEE LIFT ACTUATOR in the SERVICE section of this manual • Does the rear squeegee lift actuator pass the testing? | See TESTING REAR SQUEEGEE LIFT ACTUATOR in the SERVICE | Go to Step #5 | Replace Rear Squeegee Lift Actuator |
| 5 | <ul style="list-style-type: none"> • Key Off • Reconnect rear squeegee lift actuator to main wire harness • Test voltage applied to rear squeegee lift subsystem as shown on the electrical schematic • Are the electrical circuits operating as shown on the electrical schematic? | | Go Back to Step #1 | Identify Voltage Drop Location and Repair or Replace Necessary Components |

Terms:

LCD = Liquid Crystal Display

J5-5 = T16 Controller Connector #5, Pin #5

J5-6 = T16 Controller Connector #5, Pin #6

TROUBLESHOOTING

Scrub Head Lift

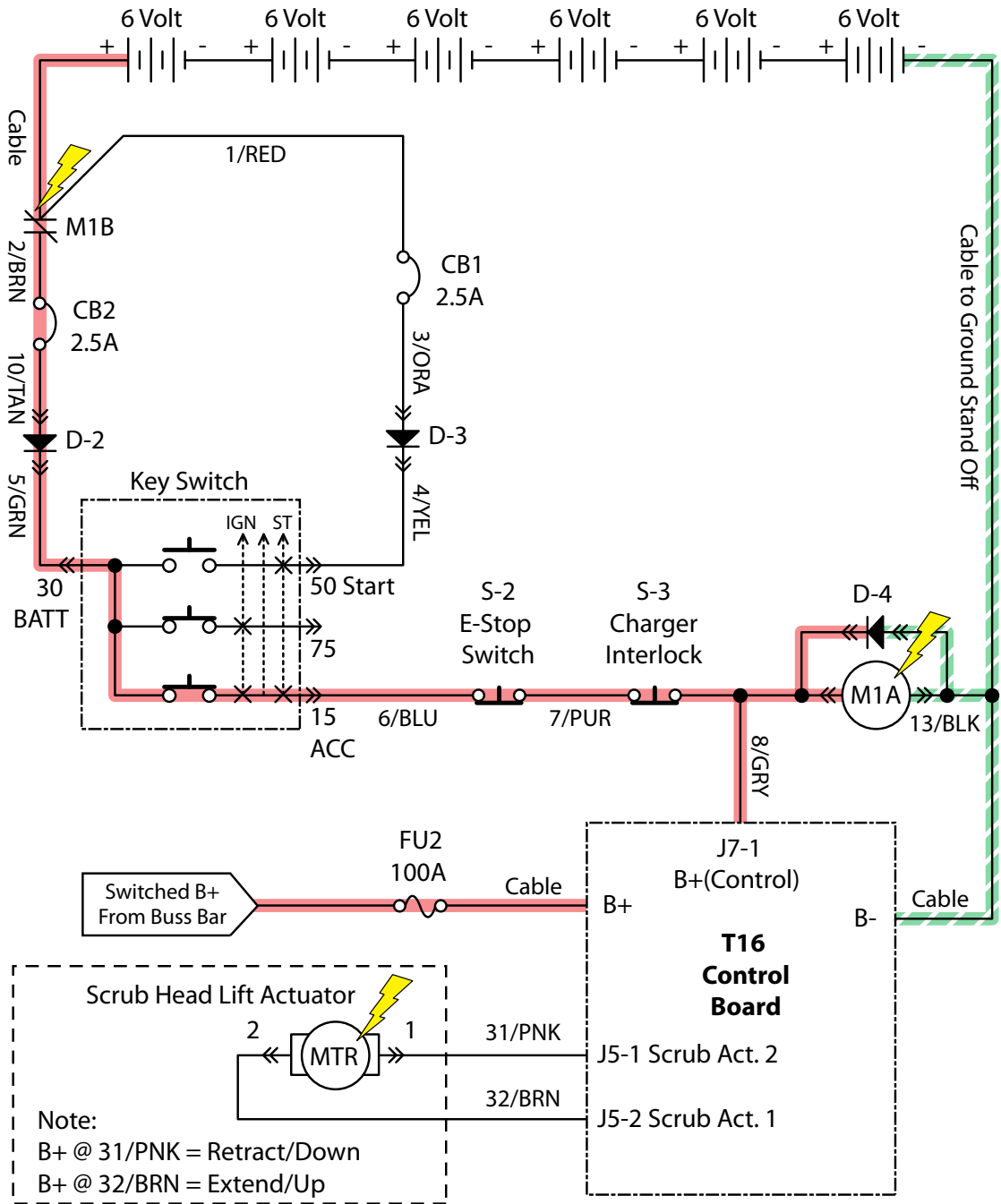

Operational Matrix:

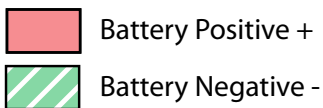

| | Enabled | Disabled |
|-----------------|---|---|
| Scrub Head Down | <ul style="list-style-type: none"> 1-STEP Scrub ON Fwd/Rev Propel | <ul style="list-style-type: none"> 1-STEP Scrub OFF Neutral-Ready State Recovery Tank Full Solution Tank Empty Very Low Batt Voltage Load Current Fault |

MSL001

Scrub Head Failed to Raise/Lower

| STEP | ACTION | VALUE(S) | YES | NO |
|------|---|--------------------------------------|---|---|
| 1 | <ul style="list-style-type: none"> • Key On • Enable scrub head down • Is there a pertinent LCD warning or fault message displayed? | | See "LCD Warnings" or "LCD Faults" Sections | Go to Step #2 |
| 2 | <ul style="list-style-type: none"> • Key Off • See "Manual Mode" section of this manual • Activate the scrub head in manual mode • Does the scrub head raise/lower? | | Go to Step #5 | Go to Step #3 |
| 3 | <ul style="list-style-type: none"> • Key Off • See "Self-Test Mode" • Does the Self-Test display output circuits J5-1 and J5-2 as open or shorted? | | Correct Open or Short Circuit Condition | Go to Step #4 |
| 4 | <ul style="list-style-type: none"> • Key Off • See TESTING MAIN BRUSH LIFT ACTUATOR in the SERVICE section of this manual • Does the scrub head lift actuator pass the testing? | See TESTING MAIN BRUSH LIFT ACTUATOR | Go to Step #5 | Replace Scrub Head Lift Actuator |
| 5 | <ul style="list-style-type: none"> • Key Off • Reconnect scrub head lift actuator to main wire harness • Test voltage applied to scrub head lift subsystem as shown on the electrical schematic • Are the electrical circuits operating as shown on the electrical schematic? | | Go Back to Step #1 | Identify Voltage Drop Location and Repair or Replace Necessary Components |

Terms:

LCD = Liquid Crystal Display

J5-2 = T16 Controller Connector #5, Pin #2

J5-3 = T16 Controller Connector #5, Pin #1

TROUBLESHOOTING

Side Brush ON (Option)

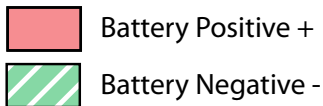
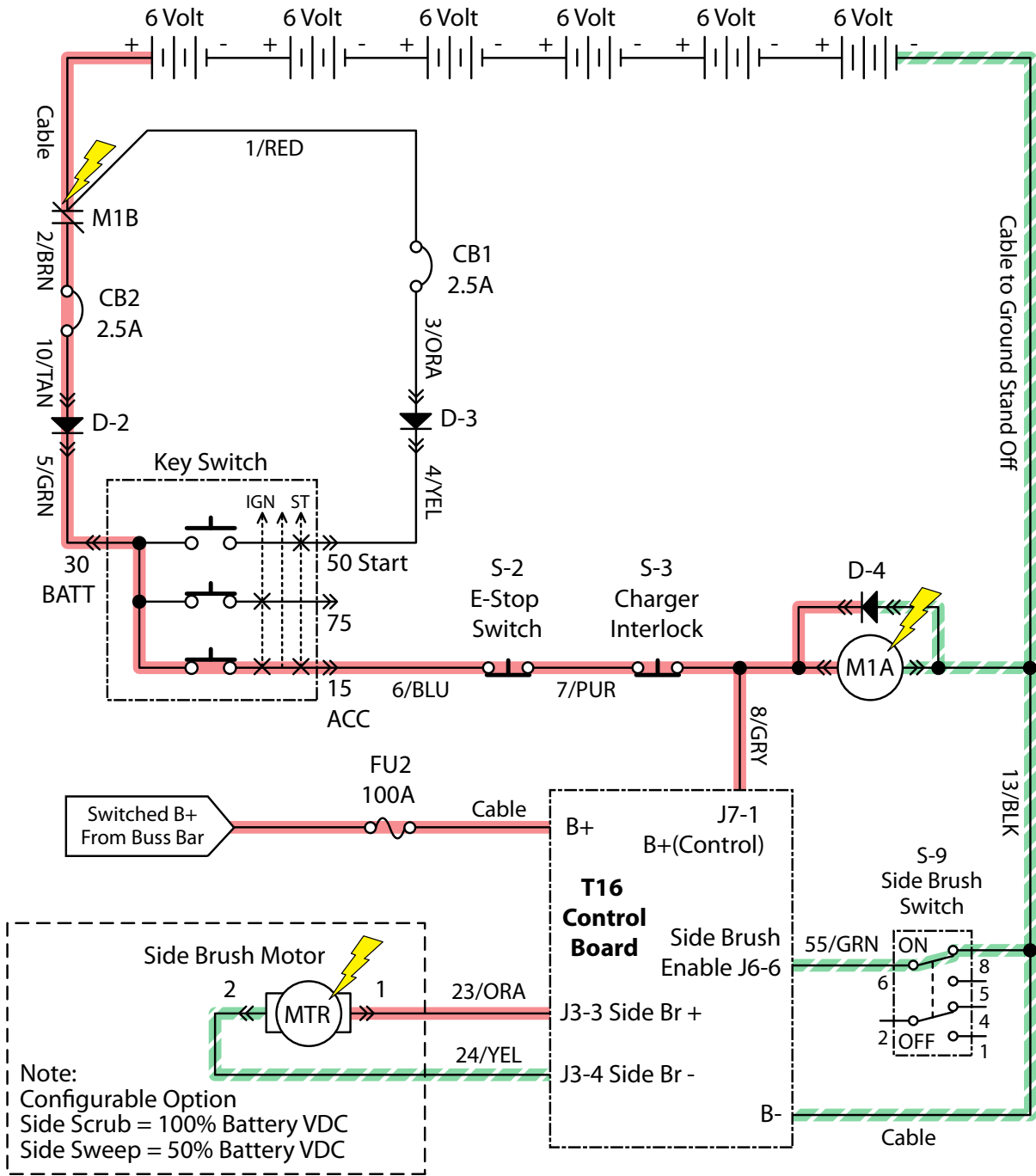

Operational Matrix:

| | Enabled | Disabled |
|-------------------|---|--|
| Side Brush | <ul style="list-style-type: none"> • 1-STEP Scrub ON • Side Brush Switch ON • Fwd/Rev Propel | <ul style="list-style-type: none"> • 1-STEP Scrub OFF • Side Brush Switch OFF • Recovery Tank Full • Solution Tank Empty • Very Low Batt Voltage • Load Current Fault • Neutral (Ready State) |

SBC001

Side Brush Failed to Turn ON (Option)

| STEP | ACTION | VALUE(S) | YES | NO |
|------|--|--|---|---|
| 1 | <ul style="list-style-type: none"> • Key On • Enable side brush • Is there a pertinent LCD warning or fault message displayed? | | See "LCD Warnings" or "LCD Faults" Sections | Go to Step #2 |
| 2 | <ul style="list-style-type: none"> • Key Off • See "Manual Mode" section of this manual • Activate the side brush in manual mode • Do the side brush turn On? | | Go to Step #6 | Go to Step #3 |
| 3 | <ul style="list-style-type: none"> • Key Off • See "Self-Test Mode" • Does the Self-Test display output circuits J3-3 and J3-4 as open or shorted? | | Correct Open or Short Circuit Condition | Go to Step #4 |
| 4 | <ul style="list-style-type: none"> • Key Off • See "Input Display Mode" • Does I7: Side Br On/Off input correspond with side brush rocker switch position? | | Go to Step #5 | Correct Faulty Input Condition |
| 5 | <ul style="list-style-type: none"> • Key Off • See TESTING SIDE BRUSH MOTOR (NON PRE-SWEEP) in the SERVICE section of this manual • Does the side brush motor pass the testing? | See TESTING SIDE BRUSH MOTOR (NON PRE-SWEEP) | Go to Step #6 | Replace Side Brush Motor |
| 6 | <ul style="list-style-type: none"> • Key Off • Reconnect side brush motor to main wire harness • Test voltage applied to side brush subsystem as shown on the electrical schematic • Are the electrical circuits operating as shown on the electrical schematic? | | Go Back to Step #1 | Identify Voltage Drop Location and Repair or Replace Necessary Components |

Terms:

LCD = Liquid Crystal Display

J3-4 = T16 Controller Connector #3, Pin #4

J3-3 = T16 Controller Connector #3, Pin #3

TROUBLESHOOTING

Side Brush Extend/Down, OFF (Option)

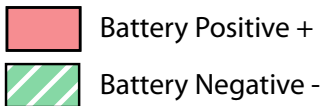
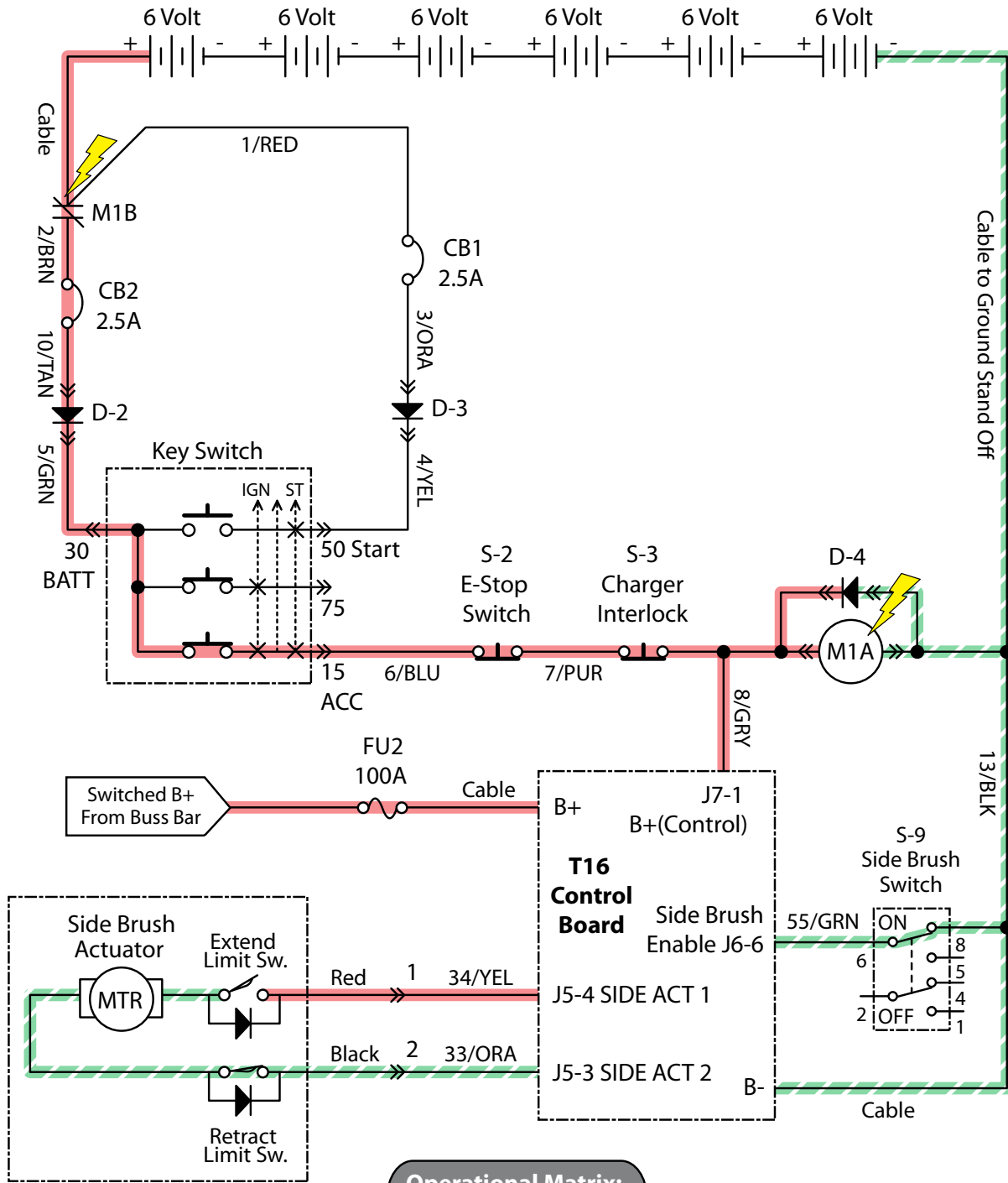

Operational Matrix:

| | Enabled | Disabled |
|-------------------------------|---|---|
| Side Brush Extend/Down | <ul style="list-style-type: none"> • 1-STEP Scrub ON • Side Brush Switch ON | <ul style="list-style-type: none"> • 1-STEP Scrub OFF • Side Brush Switch OFF • Recovery Tank Full • Solution Tank Empty • Very Low Batt Voltage • Load Current Fault |

SBED001

Side Brush Failed to Extend/Lower (Option)

| STEP | ACTION | VALUE(S) | YES | NO |
|------|---|--------------------------------------|---|---|
| 1 | <ul style="list-style-type: none"> Key On Enable side brush extend/down Is there a pertinent LCD warning or fault message displayed? | | See "LCD Warnings" or "LCD Faults" Sections | Go to Step #2 |
| 2 | <ul style="list-style-type: none"> Key Off See "Manual Mode" section of this manual Extend/Lower the side brush in manual mode Does the side brush extend/lower? | | Go to Step #6 | Go to Step #3 |
| 3 | <ul style="list-style-type: none"> Key Off See "Self-Test Mode" Does the Self-Test display output circuits J5-3 and J5-4 as open or shorted? | | Correct Open or Short Circuit Condition | Go to Step #4 |
| 4 | <ul style="list-style-type: none"> Key Off See "Input Display Mode" Does I7: Side Br On/Off input correspond with side brush rocker switch position? | | Go to Step #5 | Correct Faulty Input Condition |
| 5 | <ul style="list-style-type: none"> Key Off See TESTING SIDE BRUSH LIFT ACTUATOR in the SERVICE section of this manual Does the side brush lift actuator pass the testing? | See TESTING SIDE BRUSH LIFT ACTUATOR | Go to Step #6 | Replace Side Brush Lift Actuator |
| 6 | <ul style="list-style-type: none"> Key Off Reconnect side brush lift actuator to main wire harness Key On Side brush extend/down enabled Test voltage applied to side brush lift subsystem as shown on the electrical schematic Are the electrical circuits operating as shown on the electrical schematic? | | Go Back to Step #1 | Identify Voltage Drop Location and Repair or Replace Necessary Components |

Terms:

LCD = Liquid Crystal Display

J5-4 = T16 Controller Connector #5, Pin #4

J5-3 = T16 Controller Connector #5, Pin #3

TROUBLESHOOTING

Side Brush Retract/Up, OFF (Option)

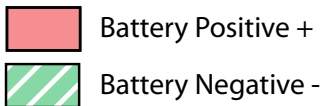
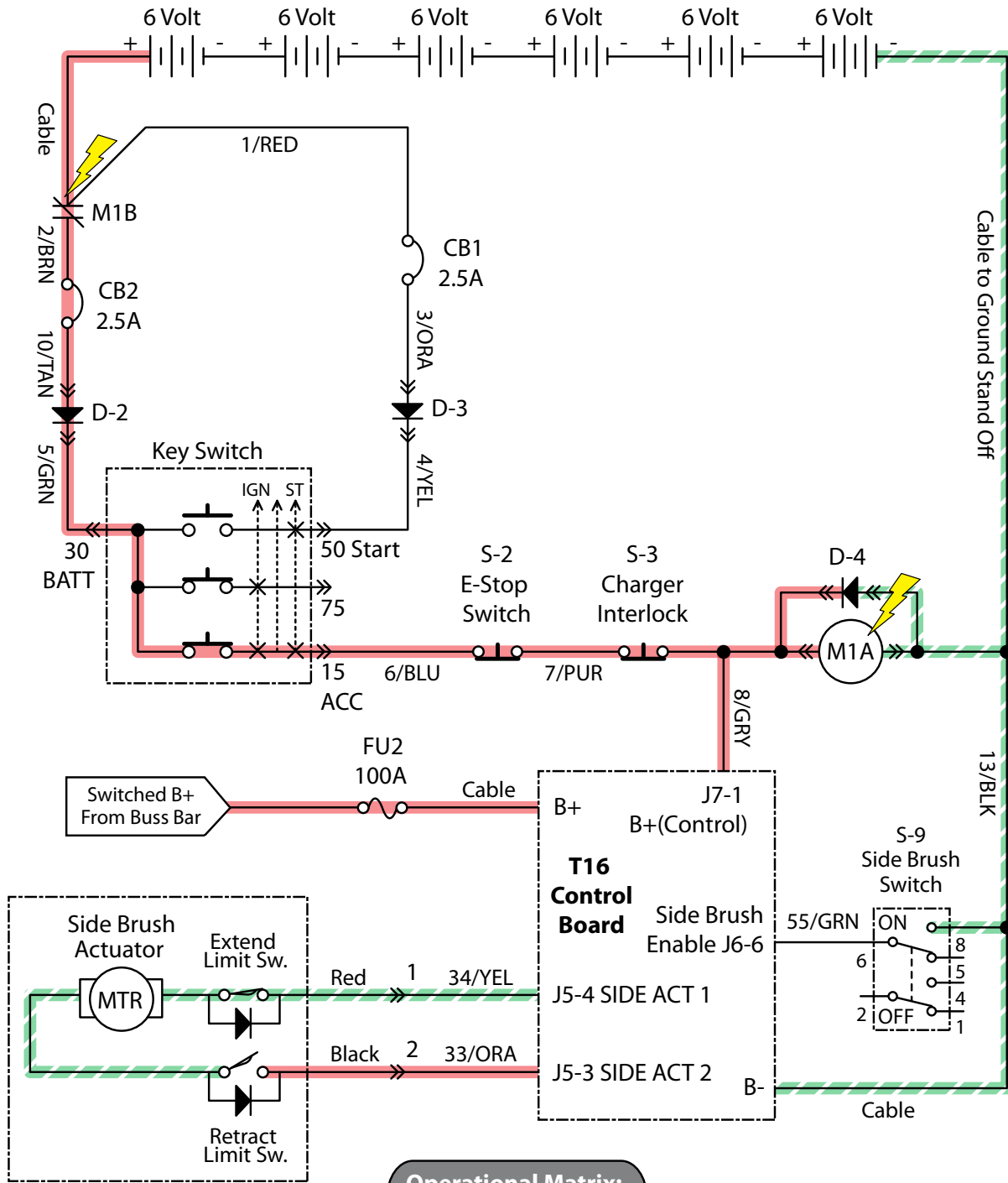

| Operational Matrix: | |
|--|---|
| Enabled | Disabled |
| Side Brush Retract/Up <ul style="list-style-type: none"> • 1-STEP Scrub OFF • Side Brush Switch OFF • Recovery Tank Full • Solution Tank Empty • Very Low Batt Voltage • Load Current Fault | <ul style="list-style-type: none"> • 1-STEP Scrub ON • Side Brush Switch ON |

SBED002

Side Brush Failed to Retract/Raise (Option)

| STEP | ACTION | VALUE(S) | YES | NO |
|------|--|--------------------------------------|---|---|
| 1 | <ul style="list-style-type: none"> • Key On • Enable side brush retract/up • Is there a pertinent LCD warning or fault message displayed? | | See "LCD Warnings" or "LCD Faults" Sections | Go to Step #2 |
| 2 | <ul style="list-style-type: none"> • Key Off • See "Self-Test Mode" • Does the Self-Test display output circuits J5-3 and J5-4 as open or shorted? | | Correct Open or Short Circuit Condition | Go to Step #3 |
| 3 | <ul style="list-style-type: none"> • Key Off • See "Input Display Mode" • Does I7: Side Br On/Off input correspond with side brush rocker switch position? | | Go to Step #4 | Correct Faulty Input Condition |
| 4 | <ul style="list-style-type: none"> • Key Off • See TESTING SIDE BRUSH LIFT ACTUATOR in the SERVICE section of this manual • Does the side brush lift actuator pass the testing? | See TESTING SIDE BRUSH LIFT ACTUATOR | Go to Step #5 | Replace Side Brush Lift Actuator |
| 5 | <ul style="list-style-type: none"> • Key On • Side brush switch Off • Test voltage applied to side brush lift subsystem as shown on the electrical schematic • Are the electrical circuits operating as shown on the electrical schematic? | | Go Back to Step #1 | Identify Voltage Drop Location and Repair or Replace Necessary Components |

Terms:

LCD = Liquid Crystal Display

J5-4 = T16 Controller Connector #5, Pin #4

J5-3 = T16 Controller Connector #5, Pin #3

TROUBLESHOOTING

Solution Control ON (Conventional)

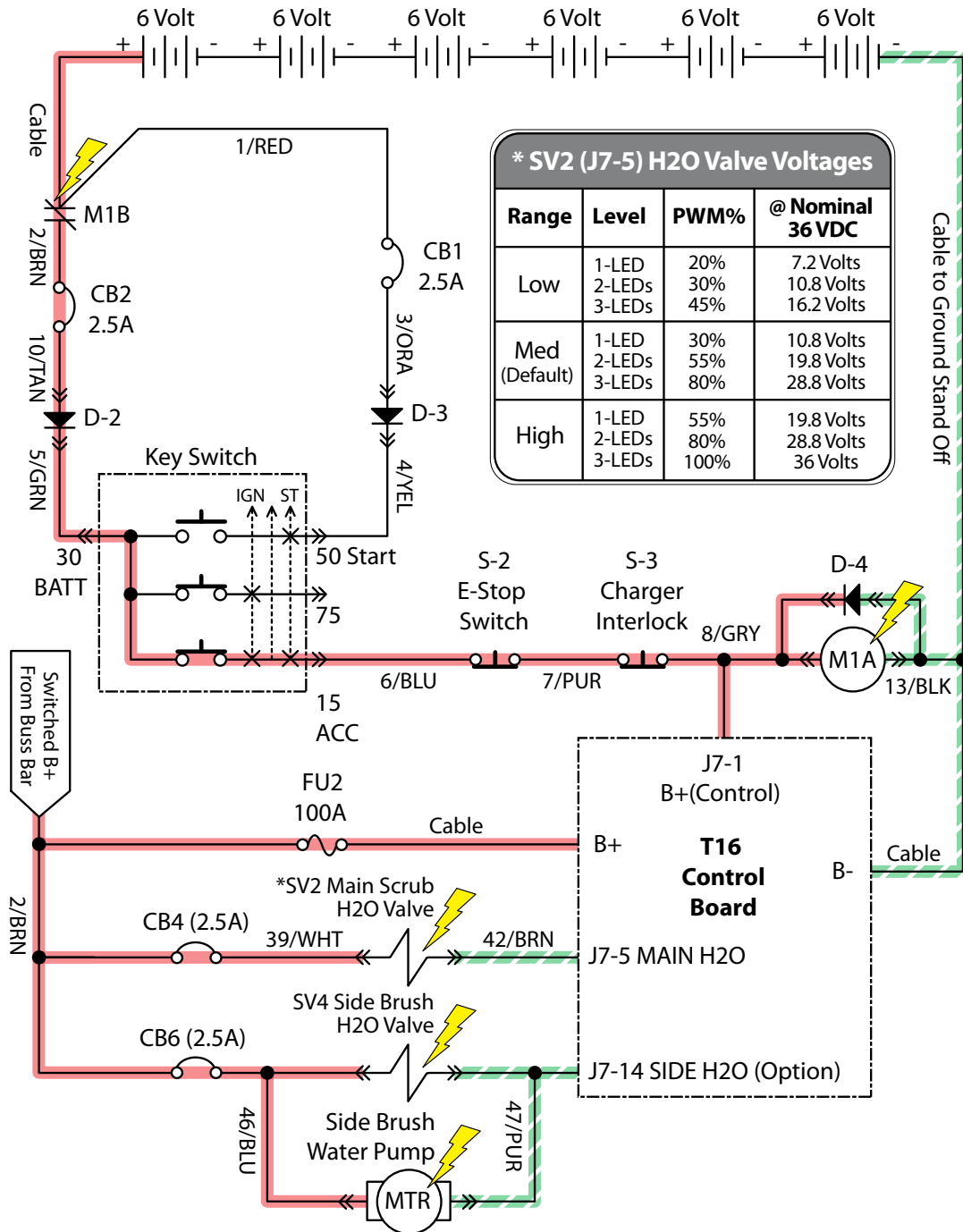

Operational Matrix:

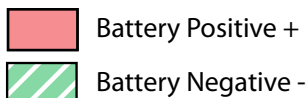

Solution Control (Conventional)

Enabled

- 1-STEP Scrub ON
- Solution Control ON
- Fwd/Rev Propel

Disabled

- 1-STEP Scrub OFF
- Solution Control OFF
- Neutral-Ready State
- Recovery Tank Full
- Solution Tank Empty
- Very Low Batt Voltage
- Load Current Fault

CSC001

Solution Control Failed to Turn ON (Conventional)

| STEP | ACTION | VALUE(S) | YES | NO |
|------|---|----------|---|---|
| 1 | <ul style="list-style-type: none"> • Key On • Enable solution control (conventional) • Is there a pertinent LCD warning or fault message displayed? | | See "LCD Warnings" or "LCD Faults" Sections | Go to Step #2 |
| 2 | <ul style="list-style-type: none"> • Key Off • See "Manual Mode" section of this manual • Activate solution control in manual mode • Does the machine dispense water to the floor? | | Go to Step #7 | Go to Step #3 |
| 3 | <ul style="list-style-type: none"> • Key Off • See "Self-Test Mode" • Does the Self-Test display output circuits J7-5 or J7-14 (side brush option) as open or shorted? | | Correct Open or Short Circuit Condition | Go to Step #4 |
| 4 | <ul style="list-style-type: none"> • Key Off • Firmly press circuit breaker #4 to reset • Is circuit breaker #4 tripped? | | Reset and Test Solution Control Operation | Go to Step #5 |
| 5 | <ul style="list-style-type: none"> • Skip this step if not equipped with optional side brush • Key Off • Firmly press circuit breaker #6 to reset • Is circuit breaker #6 tripped? | | Reset and Test Solution Control Operation | Go to Step #6 |
| 6 | <ul style="list-style-type: none"> • Key Off • Disconnect SV2, SV4, and side brush water pump from main wire harness (SV4 and water pump if equipped with side brush) • Apply battery voltage to SV2, SV4, and side brush water pump using fuse-protected jumper leads • Does the main brush and side brush dispense solution? | | Go to Step #7 | Repair or Replace SV2, SV4, or Side Brush Water Pump |
| 7 | <ul style="list-style-type: none"> • Key Off • Reconnect SV2, SV4, and side brush water pump to main wire harness • Key On • Enable solution control (conventional) • Test voltage applied to solution control subsystem as shown on the electrical schematic • Are the electrical circuits operating as shown on the electrical schematic? | | Go Back to Step #1 | Identify Voltage Drop Location and Repair or Replace Necessary Components |

Terms:

LCD = Liquid Crystal Display

J7-5 = T16 Controller Connector #7, Pin #5

J7-14 = T16 Controller Connector #7, Pin #14

SV2 = Solenoid Valve #2 (Main Brush)

SV4 = Solenoid Valve #4 (Side Brush)

TROUBLESHOOTING

Solution Control ON (ec-H2O)

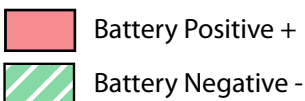
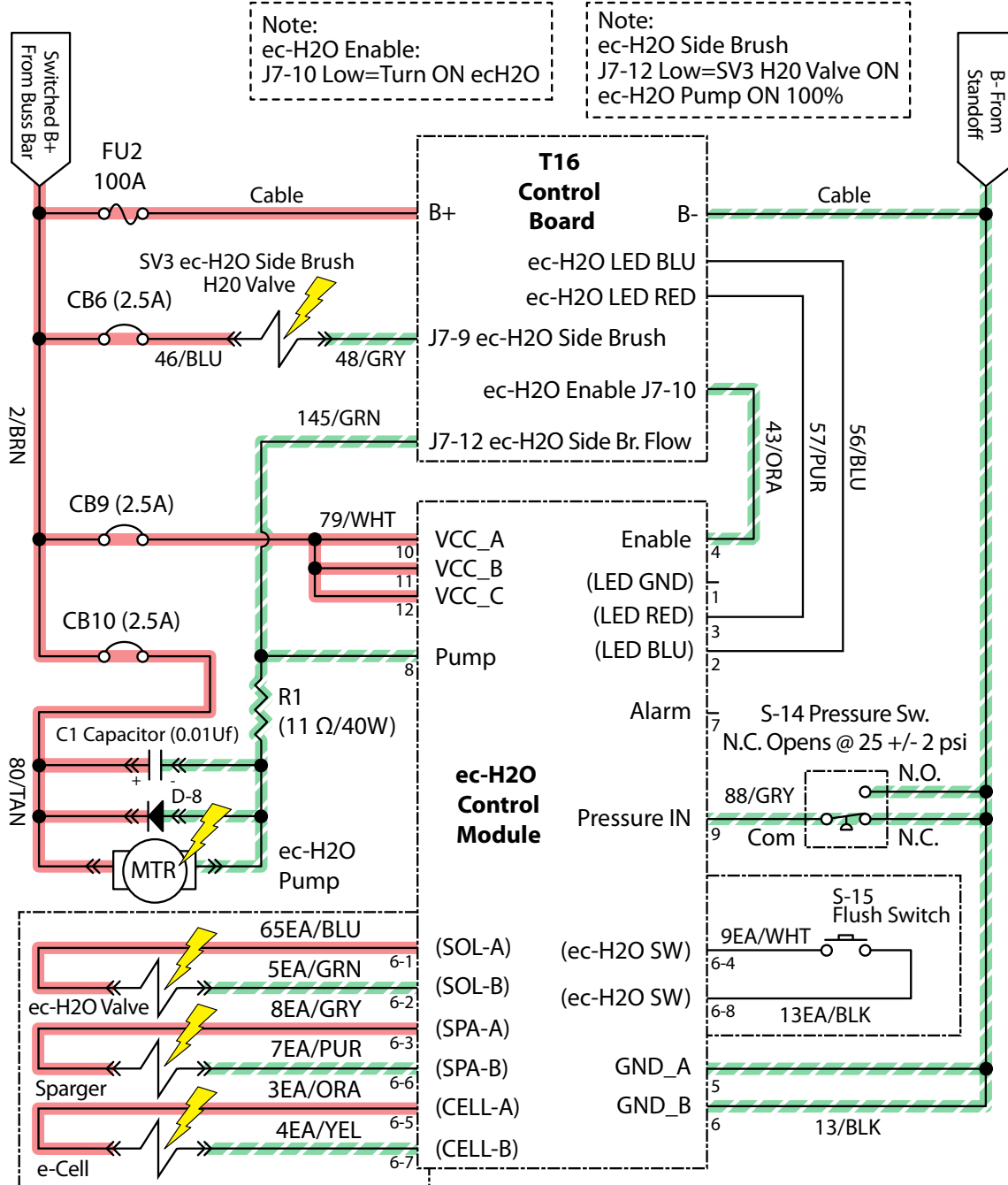

ECC001

Operational Matrix:

| Solution Control (ec-H2O) | Enabled | Disabled |
|---------------------------|--|---|
| | <ul style="list-style-type: none"> 1-STEP Scrub ON Solution Control ON ec-H2O Button ON Fwd/Rev Propel | <ul style="list-style-type: none"> 1-STEP Scrub OFF Solution Control OFF ec-H2O Button OFF Neutral-Ready State Recovery Tank Full Solution Tank Empty Very Low Batt Voltage ec-H2O System Fault Load Current Fault |

Solution Control Failed to Turn ON (*ec-H2O*)

| STEP | ACTION | VALUE(S) | YES | NO |
|------|---|----------------------|--|---|
| 1 | <ul style="list-style-type: none"> Key On Enable solution control (<i>ec-H2O</i>) Is there a pertinent LCD warning or fault message displayed? | | See "LCD Warnings" or "LCD Faults" Sections | Go to Step #2 |
| 2 | <ul style="list-style-type: none"> Key Off Firmly press circuit breakers #6, #9, and #10 to reset Is a circuit breaker tripped? | | Reset and Test <i>ec-H2O</i> Solution Control Operation | Go to Step #3 |
| 3 | <ul style="list-style-type: none"> Key Off Enable solution control (<i>ec-H2O</i>) Is the <i>ec-H2O</i> LED flashing RED, indicating a system restriction or low water conductivity*? | | See " <i>ec-H2O</i> Module Flush Procedure" Section. Then Proceed to Step #4 | Go to Step #5 |
| 4 | <ul style="list-style-type: none"> Key Off See "<i>ec-H2O</i> Module Flush Procedure" section of this manual Did the flush procedure fix the problem? | | System OK | See "Testing <i>ec-H2O</i> Pressure Switch" |
| 5 | <ul style="list-style-type: none"> Key Off See "Manual Mode" section of this manual Activate solution control (<i>ec-H2O</i>) in manual mode Does solution control (<i>ec-H2O</i>) turn On? | | Go to Step #8 | Go to Step #6 |
| 6 | <ul style="list-style-type: none"> Key Off See "Self-Test Mode" Does the Self-Test display output circuits J7-9, J7-10, or J7-12 as open or shorted? | See "Self-Test Mode" | Correct Open or Short Circuit Condition | Go to Step #7 |
| 7 | <ul style="list-style-type: none"> Key Off Disconnect <i>ec-H2O</i> water pump from wire harness Apply battery voltage to <i>ec-H2O</i> water pump using fuse-protected jumper leads Does the <i>ec-H2O</i> water pump dispense water? | | Go to Step #8 | Repair or Replace <i>ec-H2O</i> Water Pump |
| 8 | <ul style="list-style-type: none"> Key Off Reconnect <i>ec-H2O</i> water pump to wire harness Key On Enable solution control (<i>ec-H2O</i>) Test voltage applied to solution control (<i>ec-H2O</i>) system as shown on the electrical schematic Are the electrical circuits operating as shown on the electrical schematic? | | Go to Step #9 | Identify Voltage Drop Location and Repair or Replace Necessary Components |
| 9 | <ul style="list-style-type: none"> Key On Enable solution control (<i>ec-H2O</i>) Is the <i>ec-H2O</i> LED solid RED, indicating an overcurrent condition on a system component? | | Replace <i>ec-H2O</i> Module | Go Back to Step #1 |

*NOTE: Add 1/2 tablespoon of salt for every 10 gallons of water in the solution tank to increase water conductivity.

Terms:

LCD = Liquid Crystal Display

LED = Light Emitting Diode

J7-9 = T16 Controller Connector #7, Pin #9

J7-10 = T16 Controller Connector #7, Pin #10

J7-12 = T16 Controller Connector #7, Pin #12

Solution Control ON (FaST)

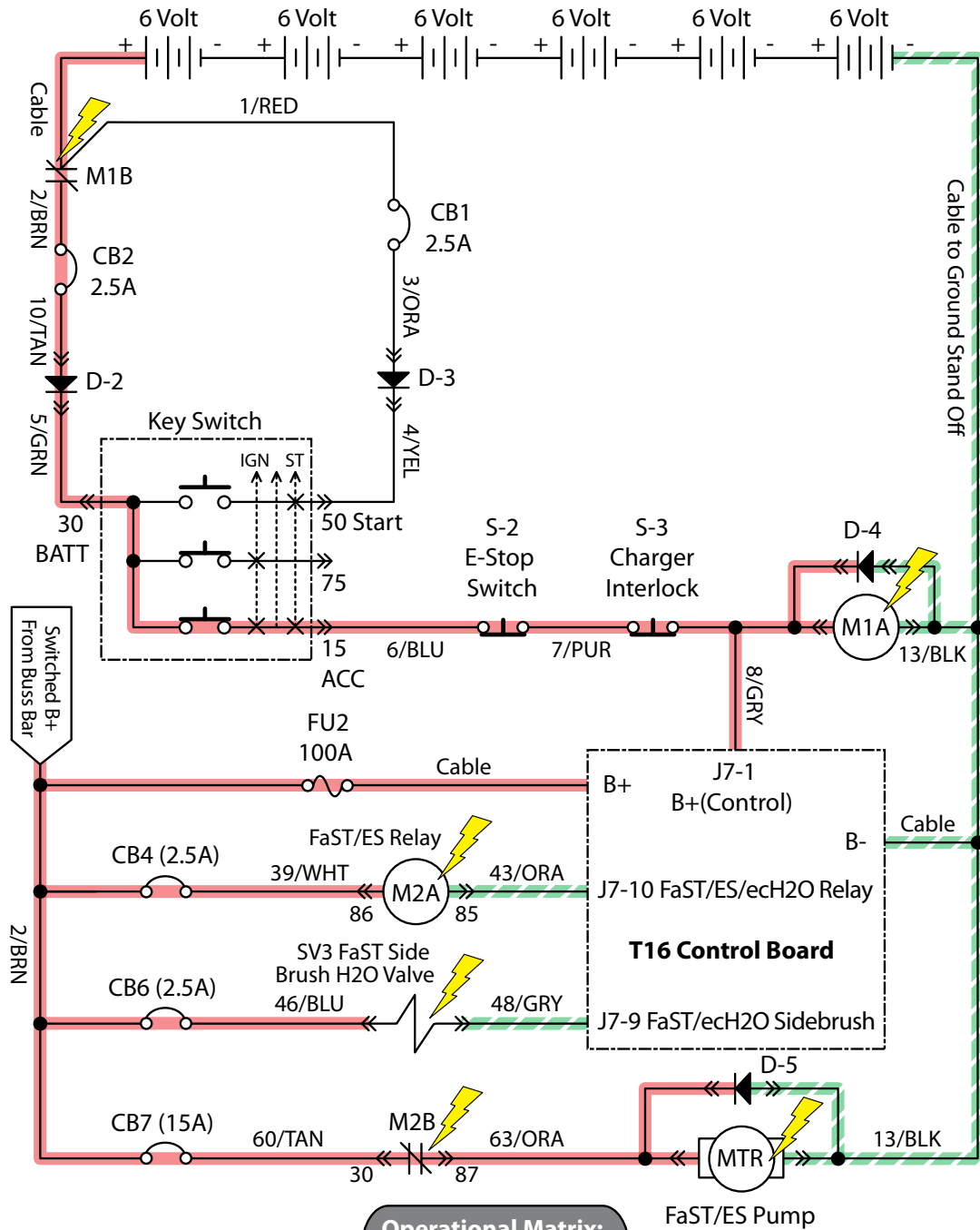

Operational Matrix:

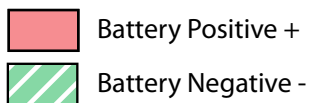

Solution Control (FaST)

Enabled

- 1-STEP Scrub ON
- Solution Control ON
- FaST Button ON
- Fwd/Rev Propel

Disabled

- 1-STEP Scrub OFF
- Solution Control OFF
- FaST Button OFF
- Neutral-Ready State
- Recovery Tank Full
- Solution Tank Empty
- Very Low Batt Voltage
- Load Current Fault

F5C001

Solution Control Failed to Turn ON (FaST)

| STEP | ACTION | VALUE(S) | YES | NO |
|------|---|-----------------------|--|---|
| 1 | <ul style="list-style-type: none"> • Key On • Enable solution control (FaST) • Is there a pertinent LCD warning or fault message displayed? | | See "LCD Warnings" or "LCD Faults" Sections | Go to Step #2 |
| 2 | <ul style="list-style-type: none"> • Key Off • Firmly press circuit breakers #4, #6, and #7 to reset • Is a circuit breaker tripped? | | Reset and Test FaST Solution Control Operation | Go to Step #3 |
| 3 | <ul style="list-style-type: none"> • Key Off • See "Manual Mode" section of this manual • Activate solution control (FaST) in manual mode • Does solution control (FaST) turn On? | | Go to Step #6 | Go to Step #4 |
| 4 | <ul style="list-style-type: none"> • Key Off • See "Self-Test Mode" • Does the Self-Test display output circuits J7-9 or J7-10 as open or shorted? | | Correct Open or Short Circuit Condition | Go to Step #5 |
| 5 | <ul style="list-style-type: none"> • Key Off • See TESTING FaST PUMP in the SERVICE section of this manual • Does the FaST water pump pass the testing? | See TESTING FaST PUMP | Go to Step #6 | Repair or Replace FaST Water Pump |
| 6 | <ul style="list-style-type: none"> • Key Off • Reconnect FaST water pump to wire harness • Key On • Enable solution control (FaST) • Test voltage applied to solution control (FaST) subsystem as shown on the electrical schematic • Are the electrical circuits operating as shown on the electrical schematic? | | Go Back to Step #1 | Identify Voltage Drop Location and Repair or Replace Necessary Components |

Terms:

LCD = Liquid Crystal Display

J7-9 = T16 Controller Connector #7, Pin #9

J7-10 = T16 Controller Connector #7, Pin #10

TROUBLESHOOTING

Spray Nozzle ON (Option)

Note: Key Switch ON

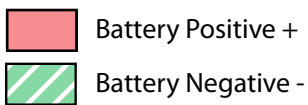
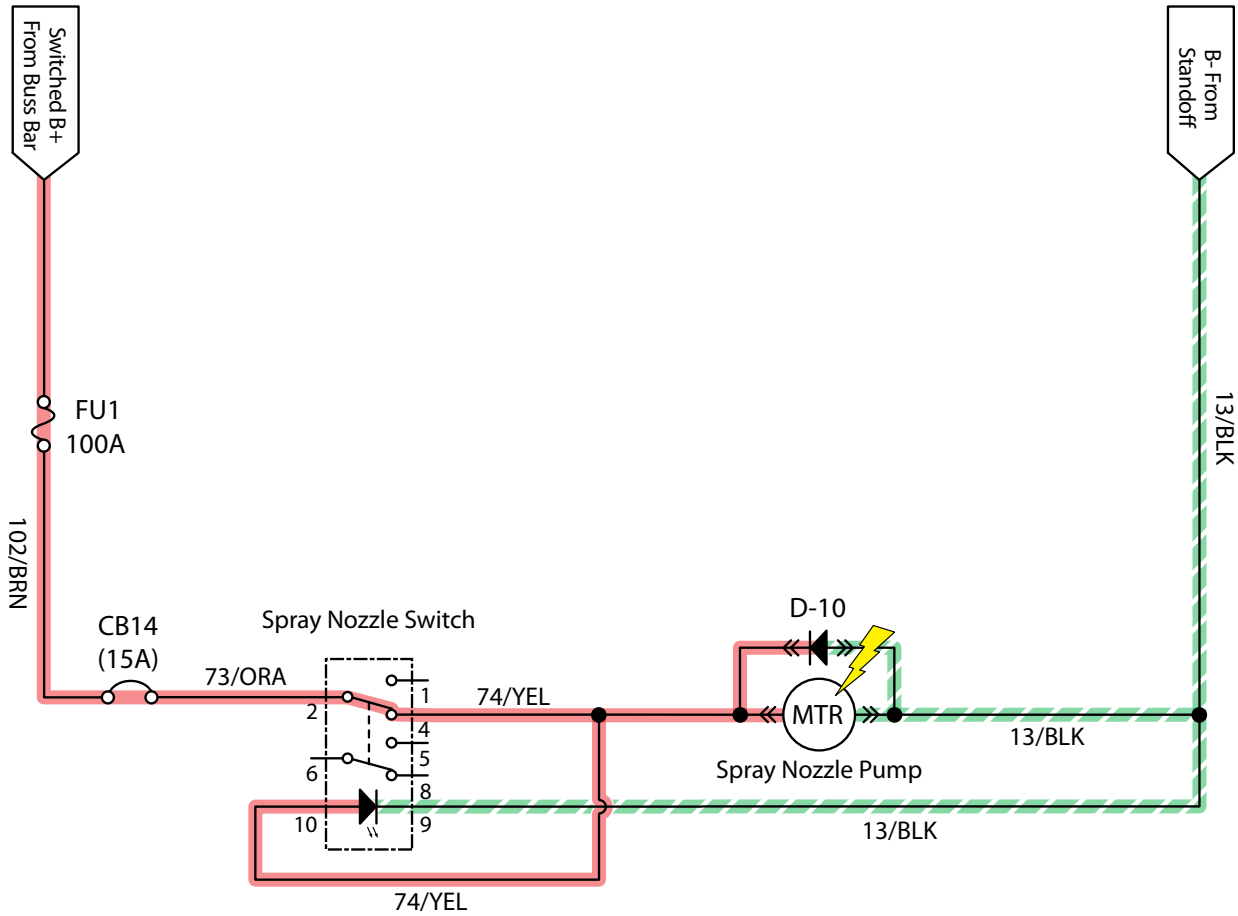

SNC001

Spray Nozzle Failed to Turn ON (Option)

| STEP | ACTION | VALUE(S) | YES | NO |
|----------|---|----------|---|---|
| 1 | <ul style="list-style-type: none"> • Key On • Enable spray nozzle subsystem • Is there a pertinent LCD warning or fault message displayed? | | See "LCD Warnings" or "LCD Faults" Sections | Go to Step #2 |
| 2 | <ul style="list-style-type: none"> • Key Off • Firmly press circuit breaker #14 to reset • Is circuit breaker #14 tripped? | | Reset and Test Spray Nozzle Operation | Go to Step #3 |
| 3 | <ul style="list-style-type: none"> • Key Off • Disconnect spray nozzle water pump from wire harness • Apply battery voltage to spray nozzle water pump using fuse-protected jumper leads • Does the spray nozzle water pump dispense water? | | Go to Step #4 | Repair or Replace Spray Nozzle Water Pump |
| 4 | <ul style="list-style-type: none"> • Key Off • Reconnect spray nozzle water pump to wire harness • Key On • Turn spray nozzle switch On • Test voltage applied to spray nozzle subsystem as shown on the electrical schematic • Are the electrical circuits operating as shown on the electrical schematic? | | Go Back to Step #1 | Identify Voltage Drop Location and Repair or Replace Necessary Components |

TROUBLESHOOTING

Vacuum Fan(s), Scrubbing ON

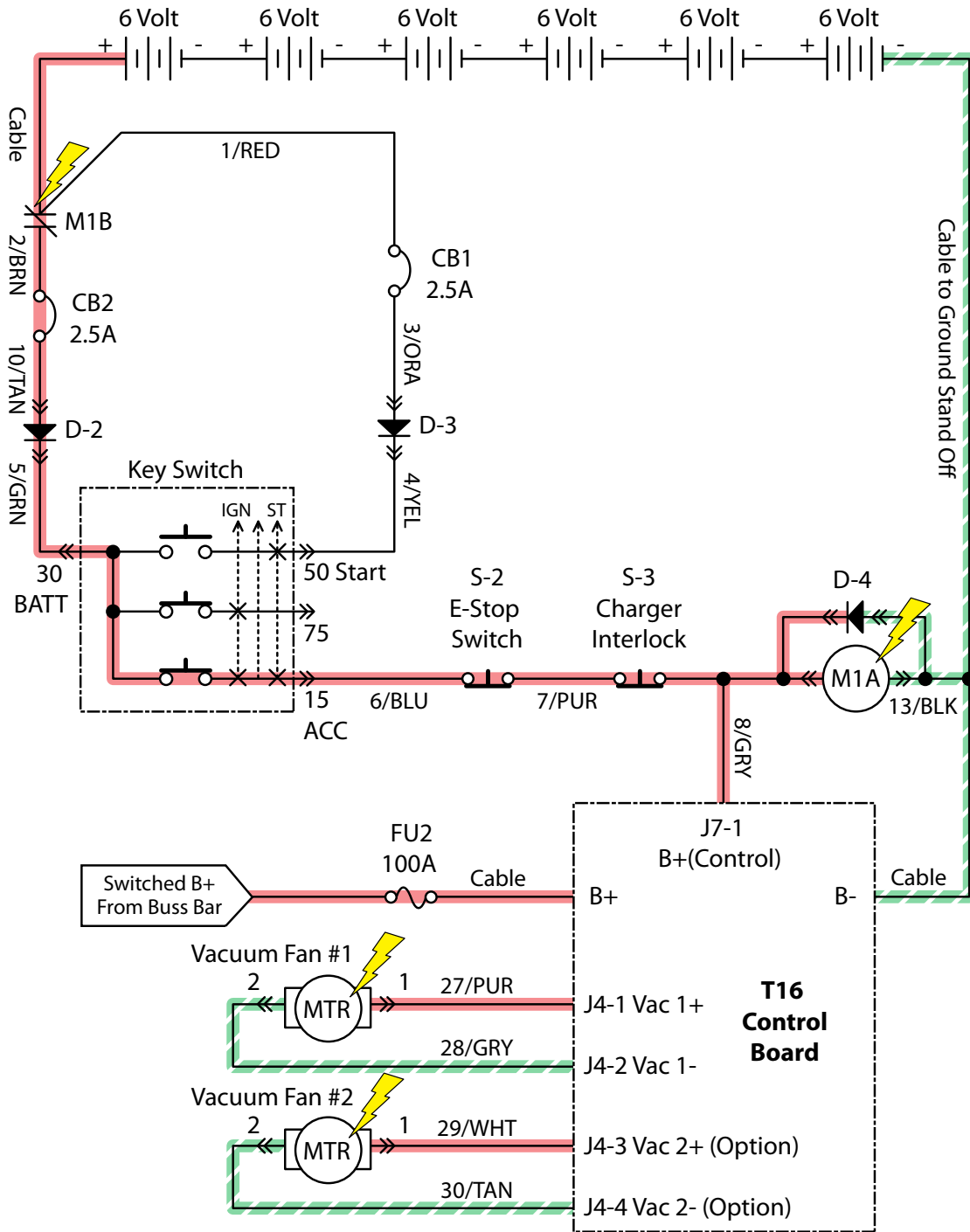

Operational Matrix:

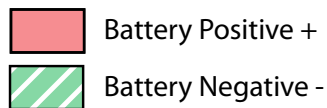

| | Enabled | Disabled |
|-------------------|--|---|
| Vacuum Fan | <ul style="list-style-type: none"> • 1-STEP Scrub ON • Squeegee/Vac ON | <ul style="list-style-type: none"> • 1-STEP Scrub OFF • Squeegee/Vac OFF • Recovery Tank Full • Very Low Batt Voltage • Load Current Fault |

VFC001

Vacuum Fan(s) Failed to Turn ON (Scrubbing)

| STEP | ACTION | VALUE(S) | YES | NO |
|------|--|---------------------------------------|---|---|
| 1 | <ul style="list-style-type: none"> Key On Enable scrubbing vacuum fan(s) Is there a pertinent LCD warning or fault message displayed? | | See "LCD Warnings" or "LCD Faults" Sections | Go to Step #2 |
| 2 | <ul style="list-style-type: none"> Key Off See "Manual Mode" section of this manual Activate vacuum fan(s) in manual mode Does the vacuum fan(s) turn On? | | Go to Step #5 | Go to Step #3 |
| 3 | <ul style="list-style-type: none"> Key Off See "Self-Test Mode" Does the Self-Test display output circuits J4-1, J4-2, J4-3, or J4-4 as open or shorted? <i>Note: J4-3,4 circuits are the optional secondary vacuum fan output and may appear open if not equipped</i> | | Correct Open or Short Circuit Condition | Go to Step #4 |
| 4 | <ul style="list-style-type: none"> Key Off See TESTING VACUUM FAN(S) (SCRUBBING) in the SERVICE section of this manual Do the vacuum fan motor(s) pass the testing? | See TESTING VACUUM FAN(S) (SCRUBBING) | Go to Step #5 | Repair or Replace Vacuum Fan Motors |
| 5 | <ul style="list-style-type: none"> Key Off Reconnect vacuum fan motor(s) to main wire harness Key On Enable scrubbing vacuum fan(s) subsystem Test voltage applied to the scrubbing vacuum fan(s) subsystem as shown on the electrical schematic Are the electrical circuits operating as shown on the electrical schematic? | | Go Back to Step #1 | Identify Voltage Drop Location and Repair or Replace Necessary Components |

Terms:

LCD = Liquid Crystal Display

J4-1 = T16 Controller Connector #4, Pin #1

J4-2 = T16 Controller Connector #4, Pin #2

J4-3 = T16 Controller Connector #4, Pin #3

J4-4 = T16 Controller Connector #4, Pin #4

TROUBLESHOOTING

Vacuum Fan, Pre-Sweep ON (Option)

Note: Key Switch ON

Note:
Pre-Sweep Enable:
J6-10 B+ = Sweep Enable ON

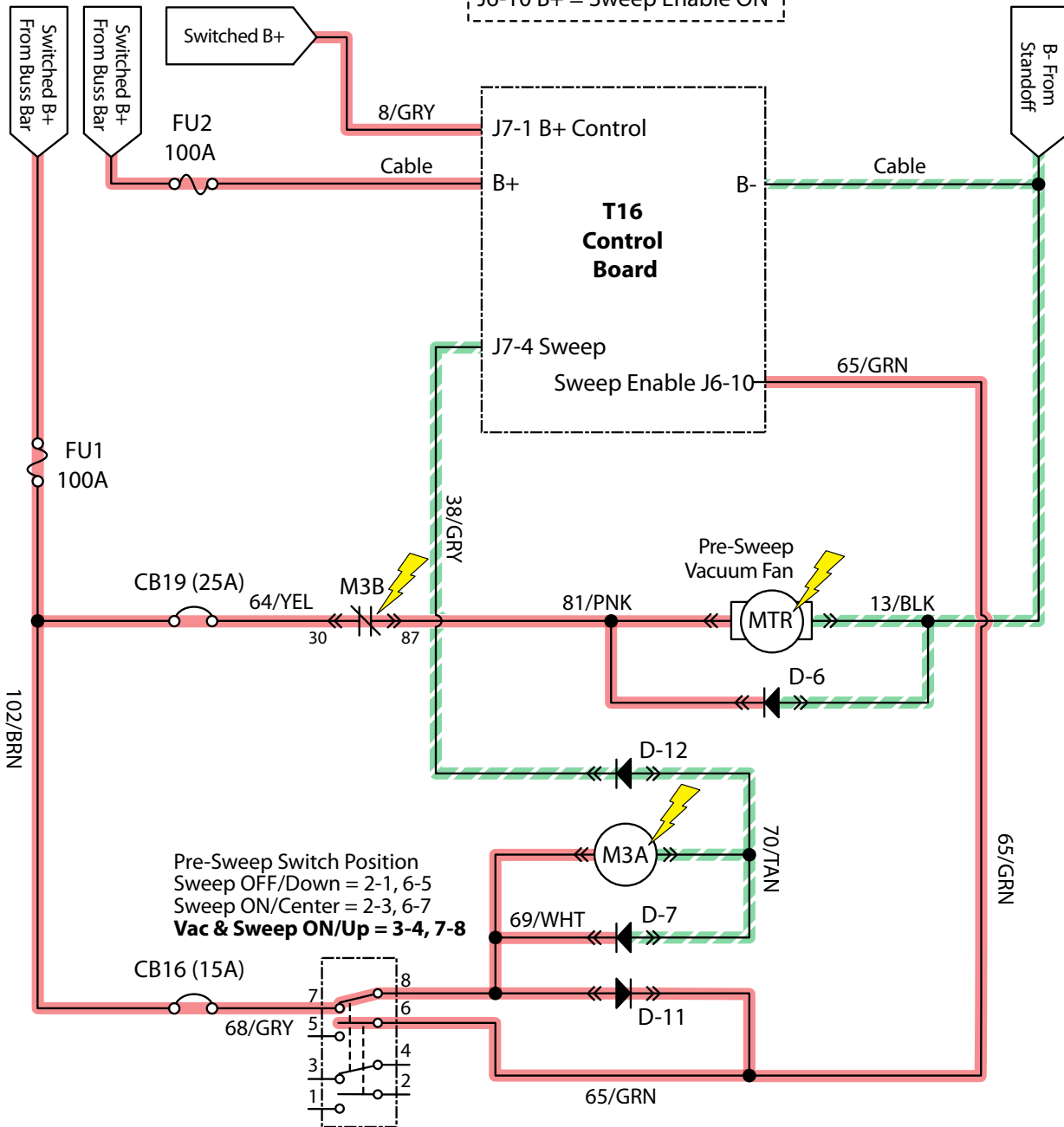

Pre-Sweep Switch Position
Sweep OFF/Down = 2-1, 6-5
Sweep ON/Center = 2-3, 6-7
Vac & Sweep ON/Up = 3-4, 7-8

Operational Matrix:

- Battery Positive +
- Battery Negative -

| | Enabled | Disabled |
|-----------------------------|--|--|
| Pre-Sweep Vacuum Fan | <ul style="list-style-type: none"> Pre-Sweep/Vacuum Switch ON Fwd/Rev Propel | <ul style="list-style-type: none"> Pre-Sweep/Vacuum Switch OFF Neutral-Ready State Very Low Battery Voltage Load Current Fault |

PSV001

Vacuum Fan Failed to Turn ON (Pre-Sweep)

| STEP | ACTION | VALUE(S) | YES | NO |
|------|---|------------------------------------|---|---|
| 1 | <ul style="list-style-type: none"> • Key On • Enable Pre-Sweep vacuum fan • Is there a pertinent LCD warning or fault message displayed? | | See "LCD Warnings" or "LCD Faults" Sections | Go to Step #2 |
| 2 | <ul style="list-style-type: none"> • Key Off • See "Self-Test Mode" • Does the Self-Test display output circuit J7-4 as open or shorted? | | Correct Open or Short Circuit Condition | Go to Step #3 |
| 3 | <ul style="list-style-type: none"> • Key Off • See "Input Display Mode" • Does I7: Side Br On/Off input correspond with side brush rocker switch position? | | Go to Step #4 | Correct Faulty Input Condition |
| 4 | <ul style="list-style-type: none"> • Key Off • See TESTING VACUUM FAN (PRE-SWEEP) in the SERVICE section of this manual • Does the Pre-Sweep vacuum fan motor pass testing? | See TESTING VACUUM FAN (PRE-SWEEP) | Go to Step #5 | Repair or Replace Vacuum Fan |
| 5 | <ul style="list-style-type: none"> • Key Off • Reconnect Pre-Sweep vacuum fan motor to wire harness • Test voltage applied to Pre-Sweep vacuum fan subsystem as shown on the electrical schematic • Are the electrical circuits operating as shown on the electrical schematic? | | Go Back to Step #1 | Identify Voltage Drop Location and Repair or Replace Necessary Components |

Terms:

LCD = Liquid Crystal Display

J7-4 = T16 Controller Connector #7, Pin #4

SECTION 5

| Contents | Page | Contents | Page |
|--|-------------|--|-------------|
| Service | | Component Testing, continued | |
| Service Procedures | 5-2 | Rear Squeegee Lift Actuator | 5-40 |
| Rear Squeegee Lift Actuator | 5-2 | Vacuum Fan(s) (Scrubbing) | 5-41 |
| Removal | 5-2 | Vacuum Fan (Pre-Sweep) | 5-42 |
| Installation | 5-3 | Main Scrub Brush Motor(s) | 5-43 |
| Side Brush Lift Actuator | 5-6 | Main Sweep Broom Motor | 5-44 |
| Removal | 5-6 | Side Brush Motor (Non Pre-Sweep) | 5-45 |
| Installation | 5-7 | Side Brush Motor (Pre-Sweep) | 5-46 |
| Main Brush Lift Actuator | 5-8 | ec-H2O Pump | 5-47 |
| Removal | 5-8 | Adjusting ec-H2O Flow Rate | 5-47 |
| Installation | 5-8 | ec-H2O Pressure Switch | 5-48 |
| Main Scrub Head | 5-9 | FaST Pump | 5-49 |
| Removal | 5-9 | ES (Extended Scrub) Pump | 5-50 |
| Installation | 5-10 | | |
| Main Scrub Brush Motor (Cylindrical) | 5-11 | | |
| Removal | 5-11 | | |
| Installation | 5-12 | | |
| Carbon Brushes | 5-12 | | |
| Side Brush Motor (Non Pre-Sweep) | 5-13 | | |
| Removal | 5-13 | | |
| Installation | 5-14 | | |
| Carbon Brushes | 5-14 | | |
| Instrument Panel | 5-15 | | |
| Removal | 5-15 | | |
| Installation | 5-15 | | |
| Logic Board | 5-16 | | |
| Removal | 5-16 | | |
| Installation | 5-17 | | |
| Steering Cable Adjustment | 5-18 | | |
| Steering Wheel Timing | 5-19 | | |
| Wheel Drive Assembly | 5-20 | | |
| Removal | 5-20 | | |
| Installation | 5-20 | | |
| Tire Replacement | 5-20 | | |
| Vacuum Fan Assembly (Scrubbing) | 5-22 | | |
| Removal | 5-22 | | |
| Installation | 5-23 | | |
| Component Testing | 5-24 | | |
| Solution Tank Level Sensor | 5-24 | | |
| Recovery Tank Level Sensor | 5-26 | | |
| Parking Brake, Electromagnetic | 5-28 | | |
| Propel Motor (and Encoder) | 5-31 | | |
| Propel Motor Cables | 5-33 | | |
| Throttle/Brake Sensor | 5-35 | | |
| Pre-Sweep Lift Actuator | 5-37 | | |
| Side Brush Lift Actuator | 5-38 | | |
| Main Brush Lift Actuator | 5-39 | | |

SERVICE

REAR SQUEEGEE LIFT ACTUATOR

REMOVING REAR SQUEEGEE LIFT ACTUATOR

FOR SAFETY: Before leaving or servicing machine, stop on level surface, turn off machine and remove key.

1. Key Off. Remove rear squeegee and set aside.



2. Remove vacuum fan housing mounting bolts. Set bracket and hardware aside.



3. Disconnect vacuum fan motor from wire harness. Set vacuum fan housing aside.



4. Remove squeegee adjustment rod-end from the pivot bracket.



5. Remove actuator mounting bolts and allow actuator to move downward to resting position.

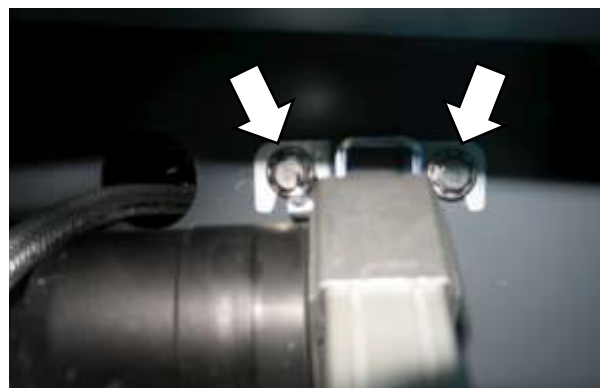

- Remove cotter pin and release coil spring tension using a pry bar. Remove clevis pin and set aside.



- Remove actuator rod-end cotter pin and then slide the clevis pin out of the lift mechanism.

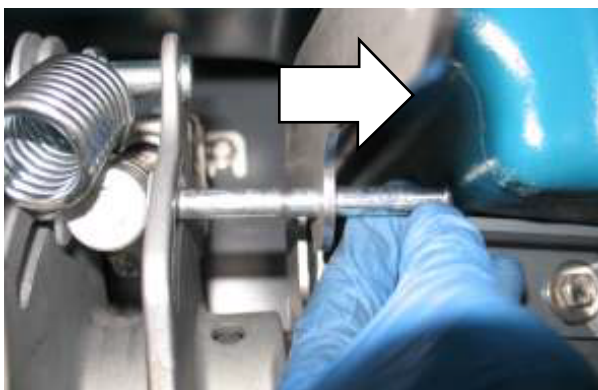

- Disconnect actuator from wire harness and remove from machine.



INSTALLING REAR SQUEEGEE LIFT ACTUATOR

- Connect new actuator to wire harness.

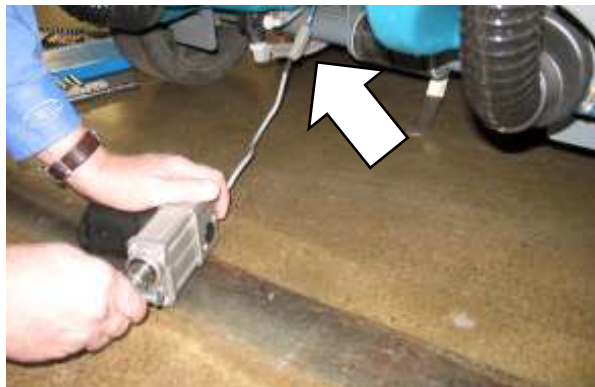

- Key On. Activate the squeegee/vacuum button and observe the rear squeegee lift actuator. Turn the key Off when the actuator stops turning/extending.

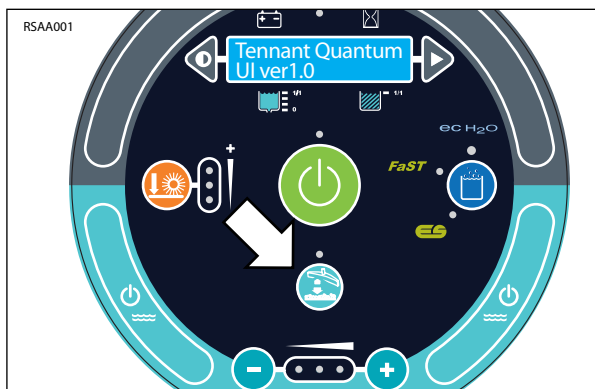

- Turn the actuator tube counter clockwise manually to extend until it stops and then clockwise just enough to align a horizontal mounting position (less than 1/2 turn). THIS IS THE INSTALLATION ADJUSTMENT.

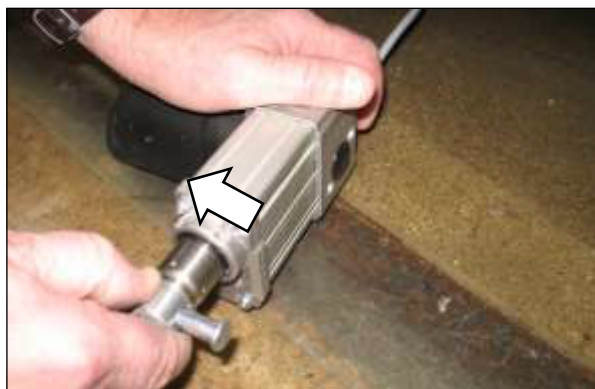

SERVICE

4. Place new actuator into mounting position.



5. Secure mounting bolts.

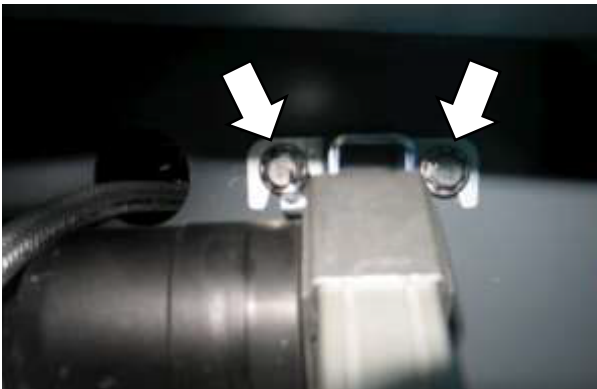

6. Insert actuator rod-end clevis and cotter pins.

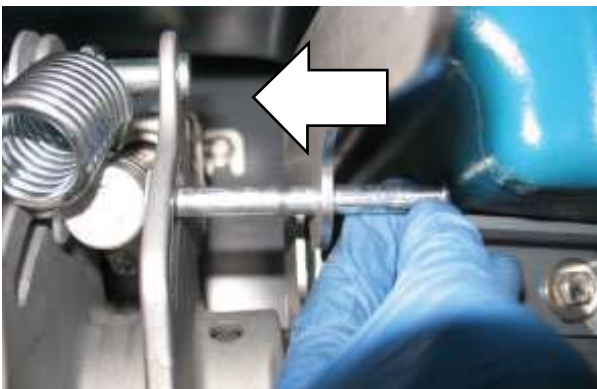

7. Apply spring tension using a pry bar and insert the clevis pin through the spring hook. Insert cotter pin.



8. Insert squeegee adjustment rod-end into the pivot bracket and secure hardware.

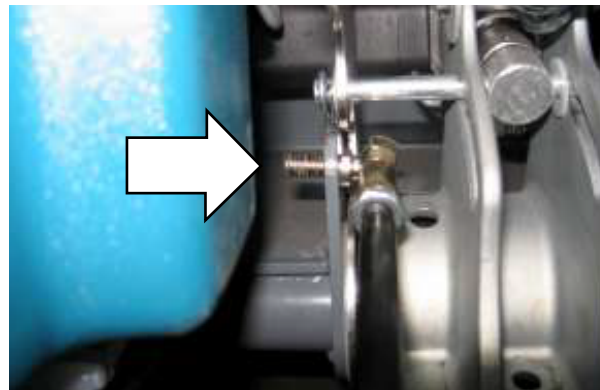

9. Reconnect vacuum fan motor to wire harness and reinstall the vacuum fan housing mounting bracket. Leave hardware loose.



10. Reinstall the vacuum fan housing. Use a pry bar to apply approximately 20 lbs (90 N) of upward force to ensure a tight seal against the recovery tank and then secure mounting bolts.



11. Turn key On to raise the lift mechanism. Reinstall the rear squeegee and reconnect suction hose.

SIDE BRUSH LIFT ACTUATOR

REMOVING SIDE BRUSH LIFT ACTUATOR

FOR SAFETY: Before leaving or servicing machine, stop on level surface, turn off machine and remove key.

NOTE: The side brush lift mechanism is under spring tension when in the raised/retracted position. There is a coil spring and a gas spring that hold the brush down and out (respectively). If the actuator fails in the retracted/raised position, lift and support the side brush using a floor jack and insert a spacer in the hinge mechanism to keep the side brush assembly from extending outward.

Skip to step 3 if the actuator failed in the extended/lowered position.

1. Key Off. Lift and support the side brush using a floor jack.

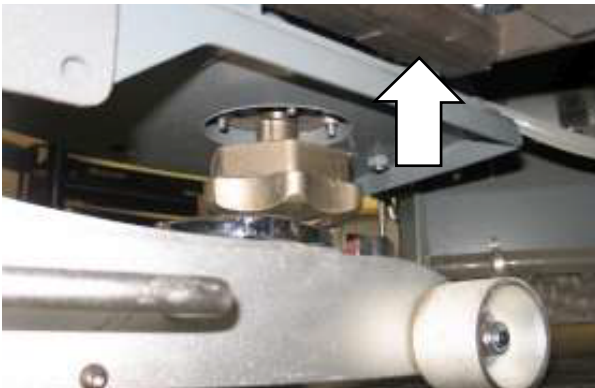

2. Insert a spacer (socket) in the side brush hinge mechanism to prevent the side brush from extending while servicing.

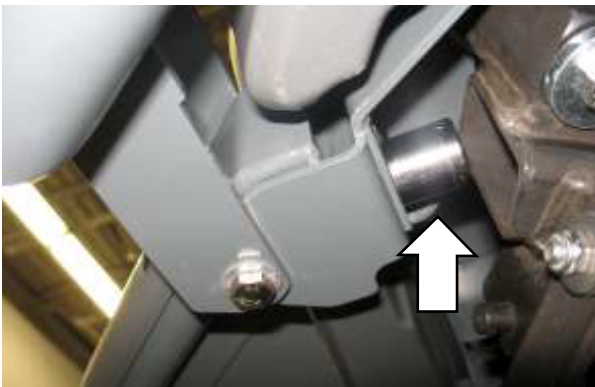

3. Remove corner roller and set aside.



4. Remove side brush lift actuator mounting bolts.



5. Remove actuator tube-end cotter and clevis pins.

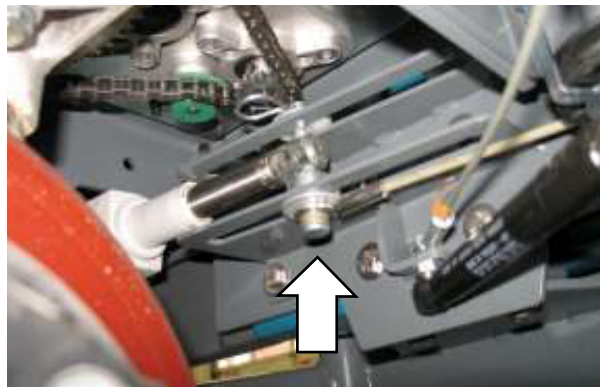

6. Disconnect actuator from wire harness and remove from machine.



INSTALLING SIDE BRUSH LIFT ACTUATOR

1. Connect actuator to wire harness.
2. Key On. Allow new actuator to fully retract and then turn Off during the normal power up sequence.



3. Key On, 1-STEP scrub On, side brush switch On. Allow the actuator tube to extend approximately 3-6 inches (7-15 cm) and then *turn the key Off*. THIS IS THE INSTALLATION ADJUSTMENT.

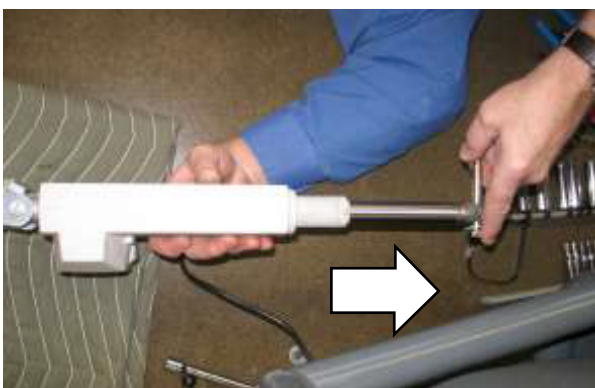

4. Place actuator into mounting location. Insert clevis and cotter pins into actuator tube..
5. Insert clevis and cotter pins through cable assembly and actuator tube.



6. Reinstall the secure the actuator mounting hardware.



7. Reinstall the corner roller.



SERVICE

MAIN BRUSH LIFT ACTUATOR

REMOVING MAIN BRUSH LIFT ACTUATOR

FOR SAFETY: Before leaving or servicing machine, stop on level surface, turn off machine and remove key.

1. Key Off. Disconnect scrub head lift actuator from wire harness.
2. Remove scrub brushes to prevent brush damage.
3. Insert spacer blocks to support scrub head weldment on both sides of the scrub head.



4. Remove actuator tube-end cotter and clevis pins

NOTE: There is spring tension on the lift mechanism. Use a pry bar to remove this clevis pin.



5. Remove actuator motor-end cotter and clevis pins.



6. Remove actuator from machine.



INSTALLING MAIN BRUSH LIFT ACTUATOR

1. Installing the main brush lift actuator is the reverse of removal.

NOTE: THIS ACTUATOR DOES NOT REQUIRE AN INSTALLATION ADJUSTMENT. Turn the actuator tube manually to align the mounting holes and insert clevis and cotter pins.

MAIN SCRUB HEAD

REMOVING MAIN SCRUB HEAD

FOR SAFETY: Before leaving or servicing machine, stop on level surface, turn off machine and remove key.

1. Key Off.
2. Remove scrub brushes and debris tray (cylindrical only).
3. Enter Manual Mode and lower scrub head completely. See Manual Mode in the Troubleshooting section of this manual. Turn key Off immediately when head touches the floor.



4. Remove actuator tube-end cotter and clevis pins

NOTE: There is spring tension on the lift mechanism. Use a pry bar to remove this clevis pin.



5. Remove scrub head linkage cotter and clevis pins from each side of the scrub head.



6. Remove scrub head lift mechanism cotter and clevis pins.

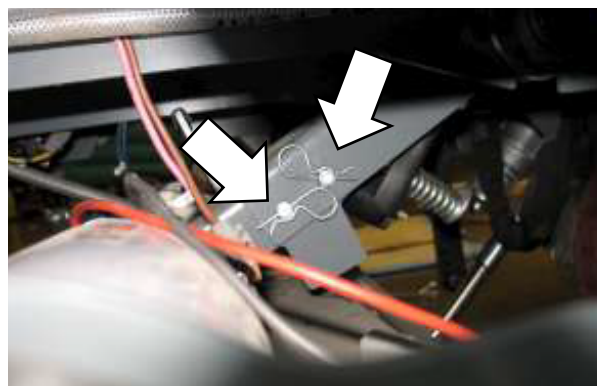

SERVICE

7. Disconnect solution supply hoses.

NOTE: This will vary based on machine scrubbing technology configuration; conventional, ES, FaST, or ec-H2O.



8. Disconnect scrub brush motors from wire harness.
9. Remove scrub head by pulling to side.



INSTALLING MAIN SCRUB HEAD

1. Installation is the reverse of removal.

MAIN SCRUB BRUSH MOTOR (CYLINDRICAL)

REMOVING MAIN BRUSH MOTOR

FOR SAFETY: Before leaving or servicing machine, stop on level surface, turn off machine and remove key.

FOR SAFETY: When servicing machine, jack machine up at designated locations only. Block machine up with jack stands.

1. Key Off. Chock rear tires and lift front of machine approximately 12 inches and support with jack stands.



2. Remove scrub brushes.
3. Enter Manual Mode and lower scrub head completely. See Manual Mode in the Troubleshooting section of this manual. Turn key Off after head lowers.



4. Remove (3) belt cover bolts and cover and set aside.



5. Remove belt by turning sprockets and applying outward pressure on the belt.



SERVICE

6. Remove (4) motor mounting bolts.



2. Remove (4) carbon brush terminal nuts and set aside.



7. Disconnect motor from wire harness and remove motor..



3. Release spring tabs using a small screwdriver.



INSTALLING MAIN BRUSH MOTOR

1. Installation of the main brush motor is the reverse of removal.

REPLACING CARBON BRUSHES

1. Release the motor band clamp and set clamp aside.



4. Remove carbon brushes.



5. Installation is the reverse of removal.

SIDE BRUSH MOTOR (NON PRE-SWEEP)

REMOVING SIDE BRUSH MOTOR

FOR SAFETY: Before leaving or servicing machine, stop on level surface.

1. Key On, 1-STEP Scrub On, side brush switch On. Turn key Off after side brush extends, but before it lowers.
2. Remove side brush squeegee and set aside.



3. Remove side brush cover and set aside.



4. Remove side brush and set aside.



5. Remove side brush drive hub.



6. Remove (4) motor mounting nuts.



7. Key On. *SIDE BRUSH WILL RETRACT!* 1-STEP Scrub On, Side Brush On and turn key Off when side brush is completely extended/down.

SERVICE

8. Disconnect side brush motor from wire harness and remove motor.



INSTALLING SIDE BRUSH MOTOR

1. Installation is the reverse of removal.

REPLACING CARBON BRUSHES

1. Remove carbon brush caps.



2. Remove carbon brushes.



INSTRUMENT PANEL

REMOVING INSTRUMENT PANEL

FOR SAFETY: When servicing machine, disconnect battery connections before working on machine.

1. Key Off. Disconnect battery.
2. Remove (6) screws securing both halves of the instrument panel assembly.



3. Remove the access panel directly below the steering wheel in the operator's compartment.



4. Disconnect the instrument panel from the wire harness.



5. Attach a static strap to prevent circuit board damage.



6. Remove the instrument panel assembly.



INSTALLING INSTRUMENT PANEL

1. Installation is the reverse of removal.

SERVICE

LOGIC BOARD REPLACEMENT

REMOVING LOGIC BOARD

FOR SAFETY: When servicing machine, disconnect battery connections before working on machine.

1. Key Off. Disconnect battery.
2. Remove tool caddy.
3. Lift seat and engage prop rod.



4. Remove cotter pins and washers from hinge mechanism.



5. Disconnect seat switch from wire harness.
6. Remove seat.

7. Remove bolt securing seat shroud.



8. Remove seat shroud.



9. Remove circuit board plastic cover.

10. Attach a static strap to prevent circuit board damage.



11. Disconnect all electrical connections.

NOTE: Always use two wrenches when securing the power supply terminals or damage to the circuit board will occur. Also, make sure the power supply terminals are secured on the new board before installation. The torque specification 52 in-lbs (6 Nm).



12. Carefully pull the logic board off the (5) plastic standoffs and remove the logic board.

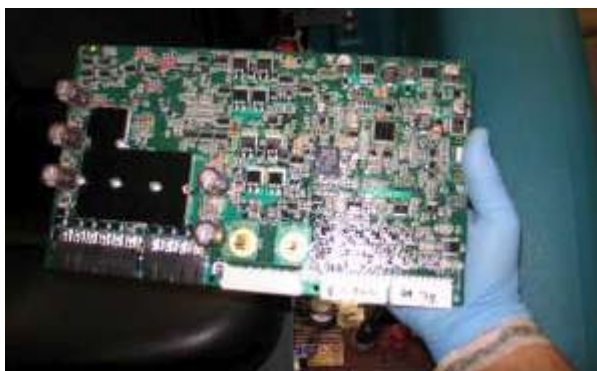

INSTALLING LOGIC BOARD

1. Installation is the reverse of removal.
2. See Configuration Mode in the Troubleshooting section of this manual. The logic board must be configured to match the actual machine configuration. For example, if the machine is configured for FaST, then FaST must be selected in Configuration Mode.

NOTE: Always use two wrenches when securing the power supply terminals or damage to the circuit board will occur. Also, make sure the power supply terminals are secured on the new board before installation. The torque specification 52 in-lbs (6 Nm).



SERVICE

STEERING CABLE ADJUSTMENT

FOR SAFETY: Before leaving or servicing machine, stop on level surface, turn off machine and remove key.

FOR SAFETY: When servicing machine, avoid moving parts. Do not wear loose jackets, shirts, or sleeves when working on machine .

1. The flex shaft cable should be assembled as shown below with 7mm (0.280 in) of exposed shaft above the bearing assembly.

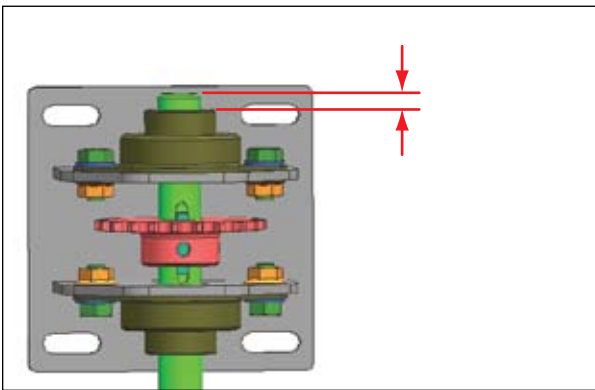

2. Align the steering sprockets and torque all set screws to 9 Nm (77 in-lbs).

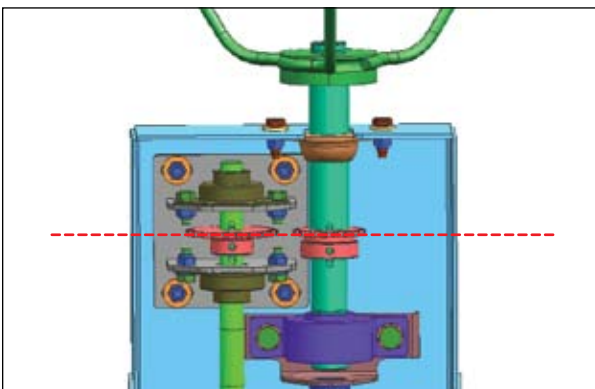

3. Pry shaft over and tighten (4) mounting nuts.

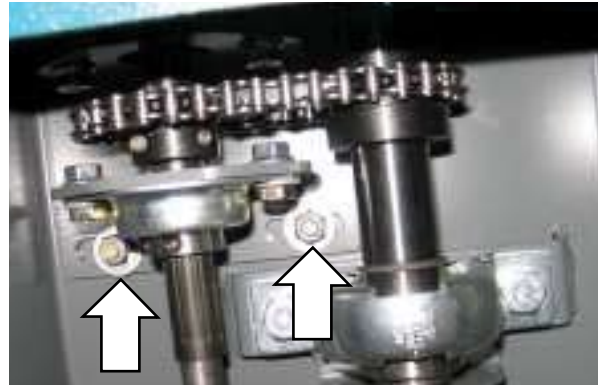

STEERING WHEEL TIMING

FOR SAFETY: Before leaving or servicing machine, stop on level surface, turn off machine and remove key.

1. Remove the lower access panel to expose the steering coupling.



2. Make sure the drive wheel is straight in alignment with the main frame.
3. Loosen the coupling hardware.



4. Set the steering wheel as shown below.



5. Retighten the coupling hardware.



SERVICE

WHEEL DRIVE ASSEMBLY

REMOVING WHEEL DRIVE ASSEMBLY

FOR SAFETY: Before leaving or servicing machine, stop on level surface, turn off machine and remove key.

FOR SAFETY: When servicing machine, jack machine up at designated locations only. Block machine up with jack stands.

FOR SAFETY: When servicing machine, disconnect battery connection before working on machine.

1. Key Off. Disconnect batteries.
2. Remove (4) drive assembly mounting bolts.

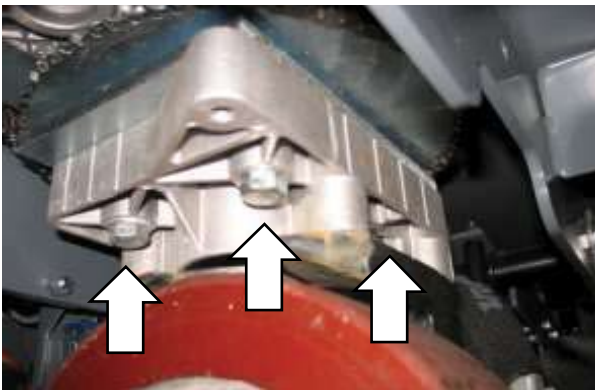

3. Note orientation of wheel drive assembly to steering assembly.
4. Chock rear tires and lift front of machine using a jack and support with jack stands. Slide drive assembly out from below machine.



5. Remove terminal box cover.



6. Disconnect propel cables and wiring from wheel drive assembly.



INSTALLING WHEEL DRIVE ASSEMBLY

1. Installation is the reverse of removal.

REPLACING THE DRIVE TIRE

1. Remove (4) flat head screws.

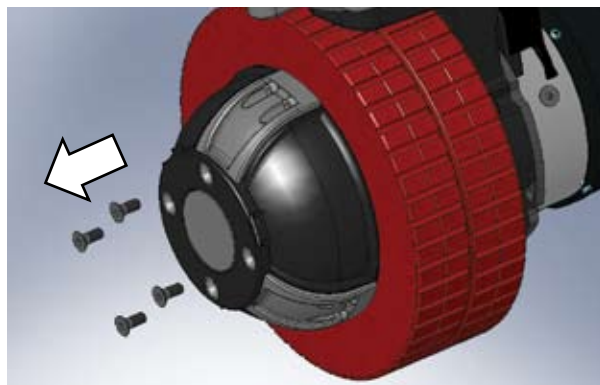

- Use (4) M10-1.5 x 70 (Class 12.9) socket head bolts to mechanically press off the tire. Tighten the bolts evenly in a diagonal pattern. REMOVE THE BOLTS AFTER THIS STEP IS COMPLETE.



- Remove (6) socket head screws.

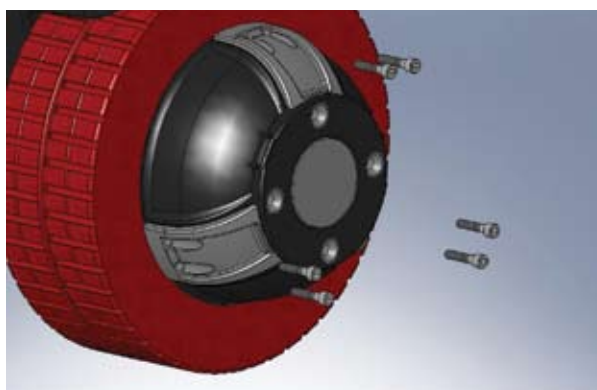

- Remove aluminum hub and plastic cover.

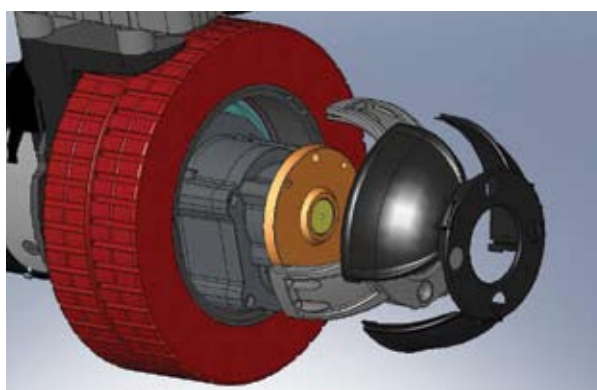

- Replace the drive tire.

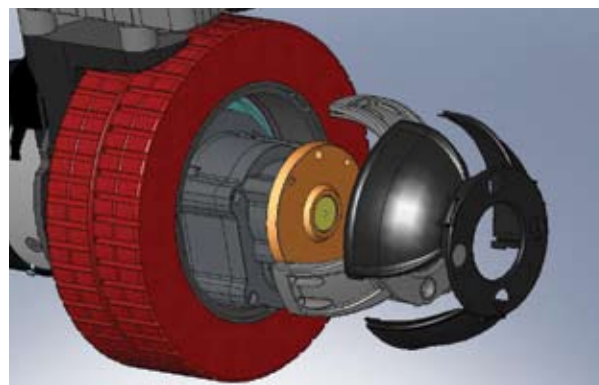

- Installation is the reverse of removal. Use a plastic mallet to reassemble the wheel drive assembly. Torque M6 hardware to 15Nm (11 ft-lbs) and M8 hardware to 22 Nm (16 ft-lbs).

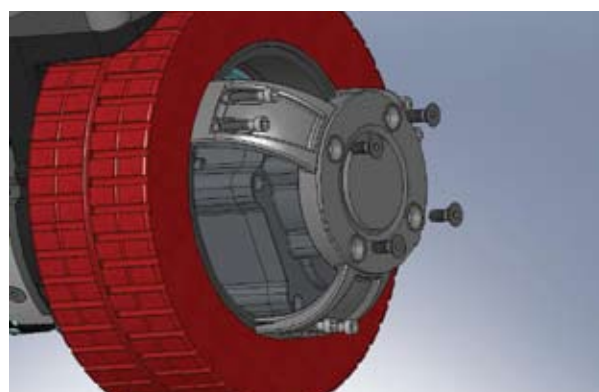

SERVICE

VACUUM FAN ASSEMBLY (SCRUBBING)

REMOVING VACUUM FAN ASSEMBLY

FOR SAFETY: Before leaving or servicing machine, stop on level surface, turn off machine and remove key.

1. Key Off.
2. Remove (2) vacuum fan housing mounting bolts.



3. Remove vacuum fan housing and disconnect vacuum fan motor from wire harness.



4. Loosen vacuum fan mounting clamp.



5. Remove vacuum fan from housing.



6. Inspect mounting boot for damage. Replace if damaged.



INSTALLING VACUUM FAN ASSEMBLY

1. Installation is the reverse of removal.
2. Reinstall the vacuum fan housing. Use a pry bar to apply approximately 20 lbs (90 N) of upward force to ensure a tight seal against the recovery tank and then secure mounting bolts.



SERVICE

TESTING SOLUTION TANK LEVEL SENSOR

FOR SAFETY: Before leaving or servicing machine, stop on level surface.

1. Key On. Backprobe solution tank level sensor connector terminals A and B using a voltmeter as shown below. The voltmeter should display 10-12 volts.

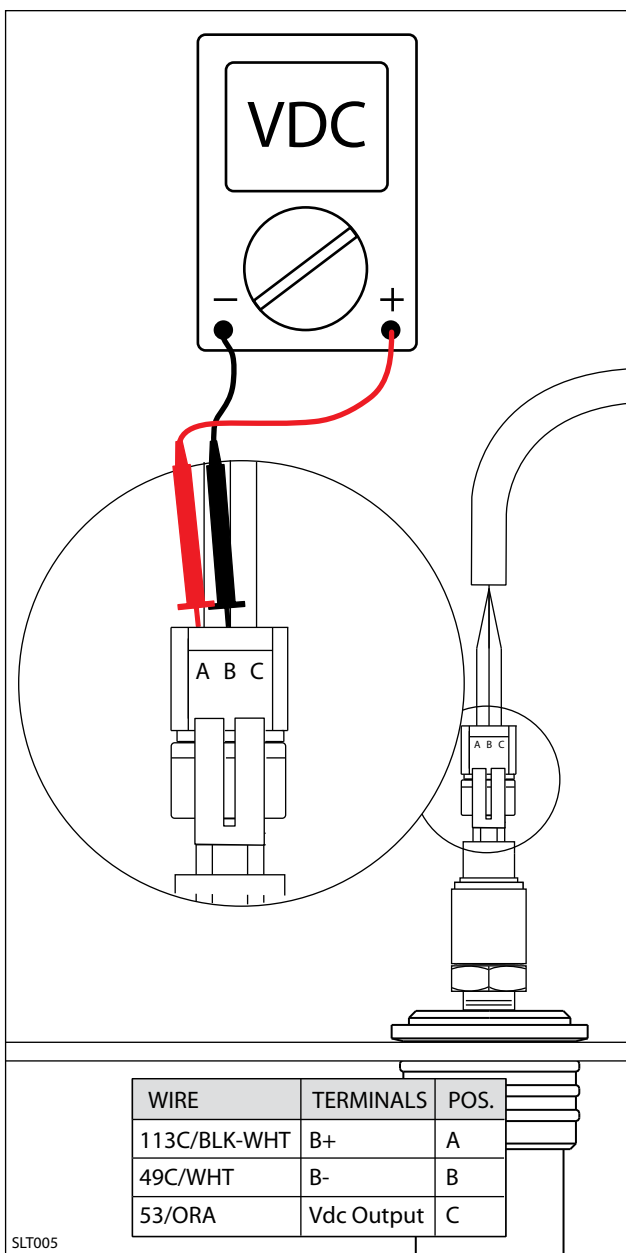

2. Key On. Backprobe solution tank level sensor connector terminals B and C using a voltmeter as shown below. The voltmeter should display 1-5 volts depending on solution tank water level.

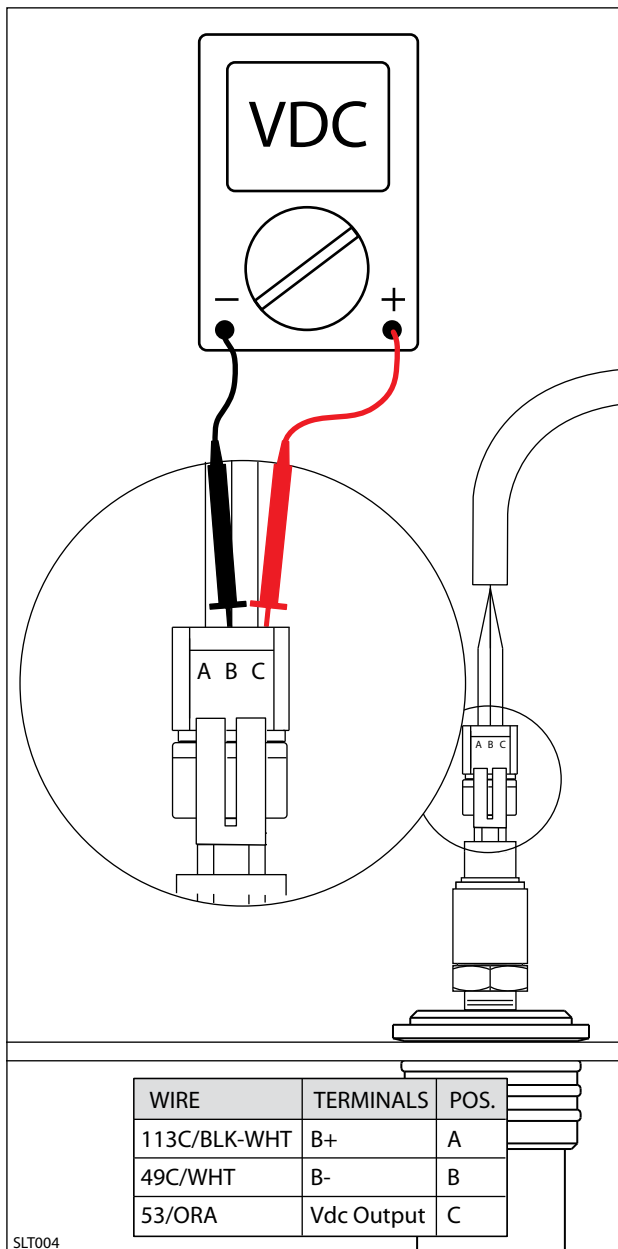

3. Drain the solution tank.
4. Slowly fill the solution tank with water and compare the actual voltmeter readings to the chart below. Replace the sensor if the values are not within specification.

| Solution Tank Sensor Output | |
|-----------------------------|-------------------|
| Tank Level | Output Voltage |
| 0% (Empty) | 1.0 - 1.17 Volts |
| 20% | 1.17 - 1.6 Volts |
| 40% | 1.6 - 1.89 Volts |
| 60% | 1.89 - 2.25 Volts |
| 80% | 2.25 - 2.4 Volts |
| 100% (Tank Full) | 2.4 + Volts |

SLT002

5. The solution tank level sensor output is also viewable in Input Display Mode. See "Input Display Mode" in the TROUBLESHOOTING section.

NOTE: "XXXX Filt(Raw)" refers to encrypted software code and should be ignored in the "I1" input mode utility. The numbers "2(2)," as shown below, represent the solution tank water level from 1 to 5 bars on the LCD. For example, when filling an empty solution tank, the numbers will increase gradually from 0(0) to 5(5) in a 0(0), 0(1), 1(1), 1(2), 2(2), 2(3)... sequence.

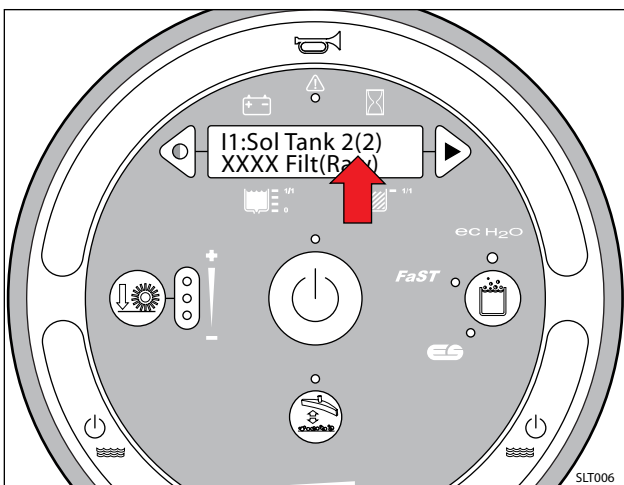

TESTING RECOVERY TANK LEVEL SENSOR

FOR SAFETY: Before leaving or servicing machine, stop on level surface.

1. Test the resistance of the recovery tank level sensor using an ohmmeter as shown below. The tank level switch should test as "O.L." or open.

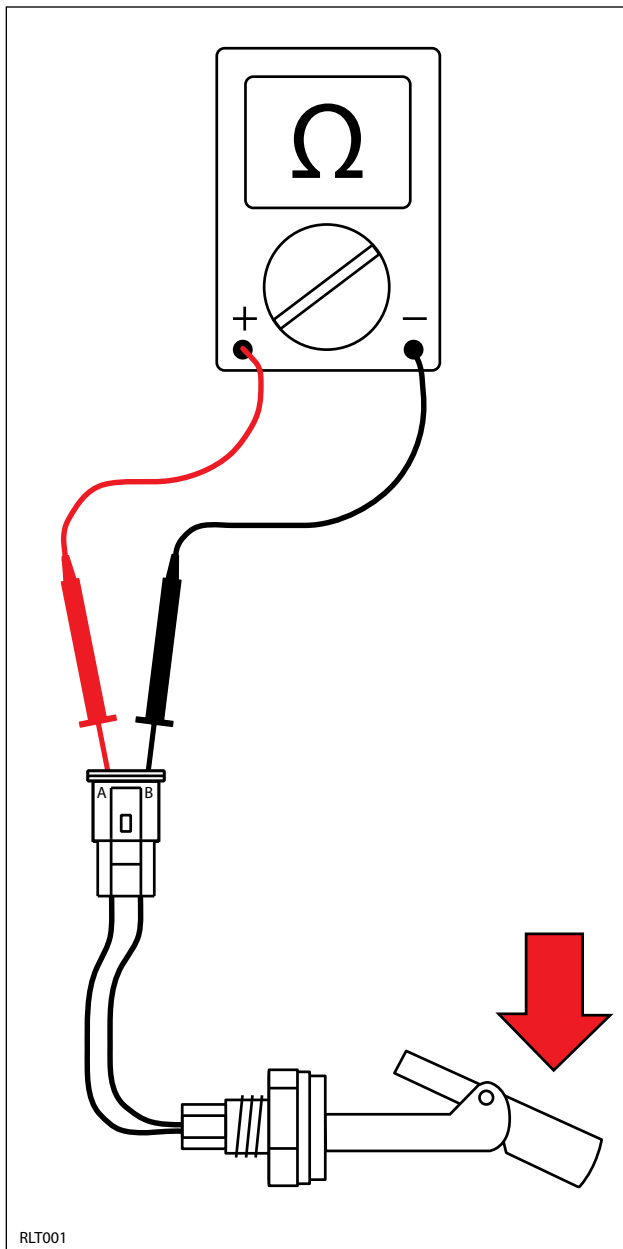

2. Test the resistance of the recovery tank level sensor using an ohmmeter as shown below. The tank level switch should test at 0-1 ohms or closed.

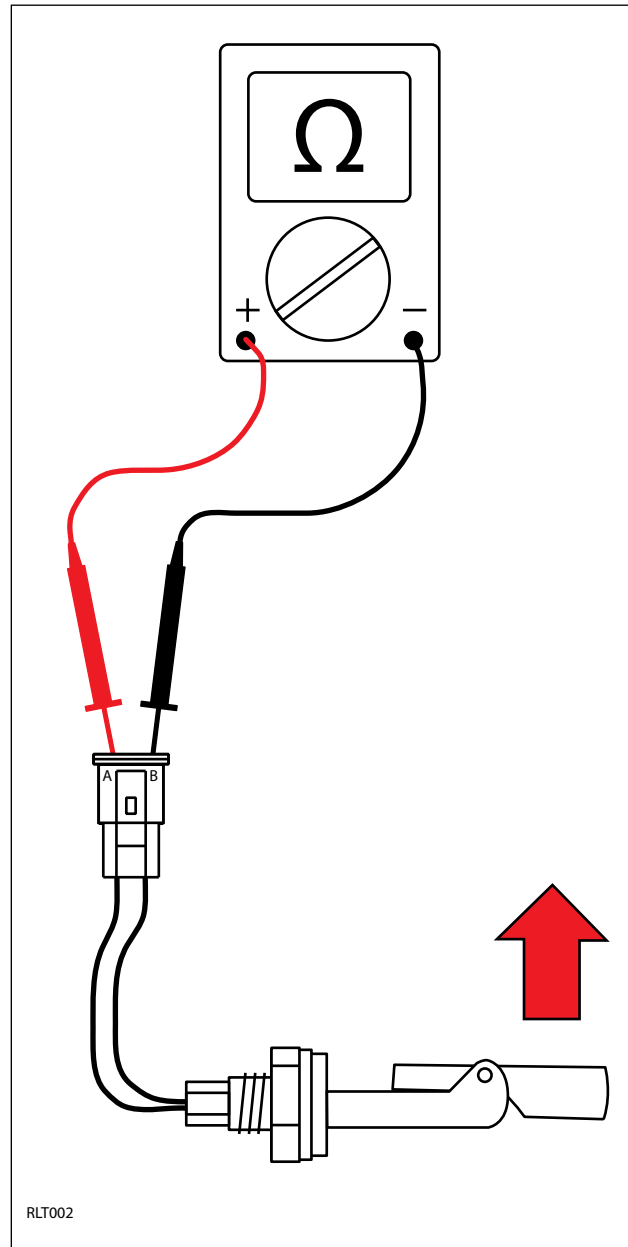

3. The recovery tank full sensor condition is also viewable in Input Display Mode. See "Input Display Mode" in the TROUBLESHOOTING section.

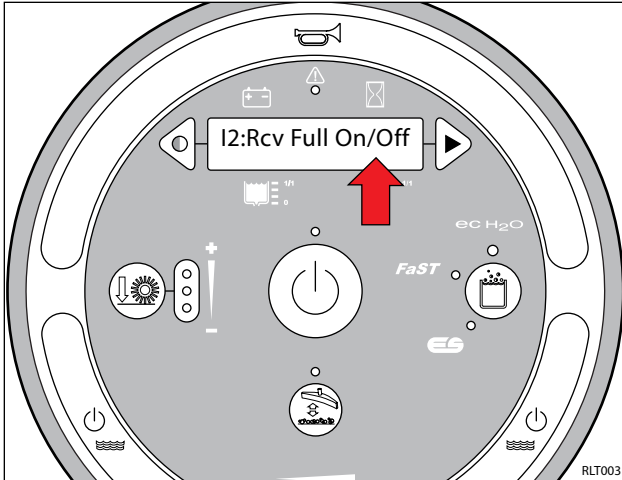

4. The optional recovery tank 1/2 full ES sensor condition is also viewable in Input Display Mode. See Input Display Mode in the TROUBLESHOOTING section of this manual.

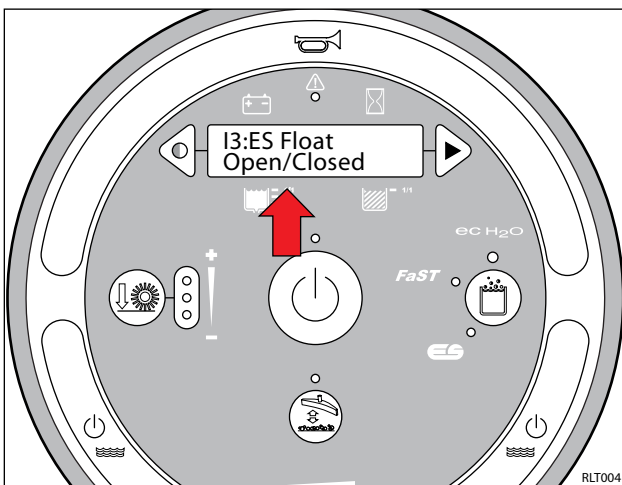

SERVICE

TESTING PARKING BRAKE, ELECTROMAGNETIC

FOR SAFETY: Before leaving or servicing machine, stop on level surface, turn off machine and remove key.

FOR SAFETY: When servicing machine, disconnect battery connection before working on machine.

1. Key Off. Remove brake cover mounting screws and set cover and hardware aside.

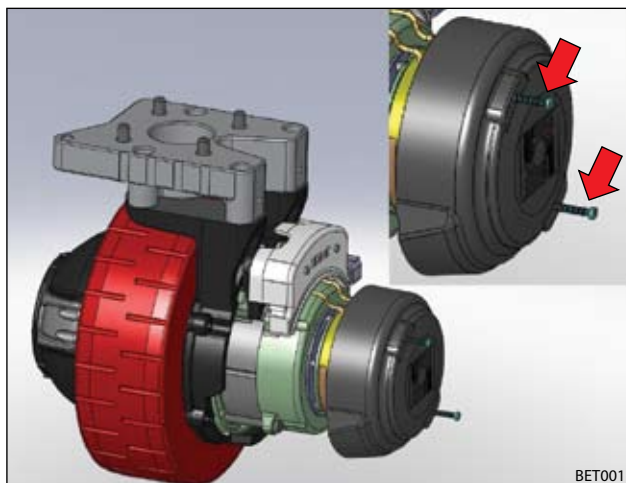

2. Key Off. Remove brake assembly mounting screws and set aside. Leave brake assembly on the splined shaft.

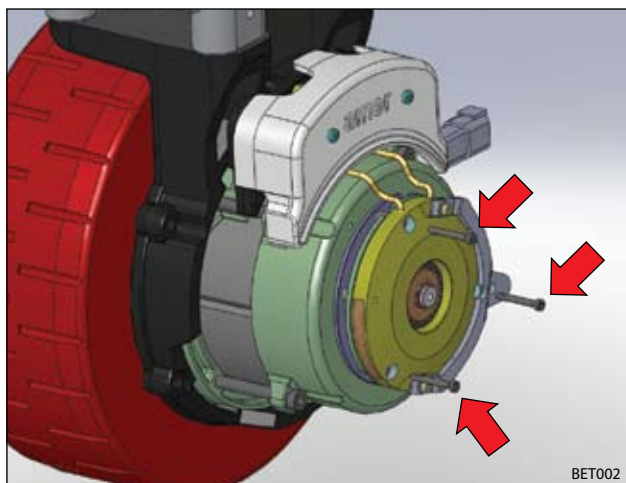

3. Key Off. The brake applies when the key switch is turned off. Attempt to manually rotate the brake assembly on the splined shaft as shown below. The brake assembly SHOULD NOT rotate freely on the splined shaft when the wheel is in a fixed position.

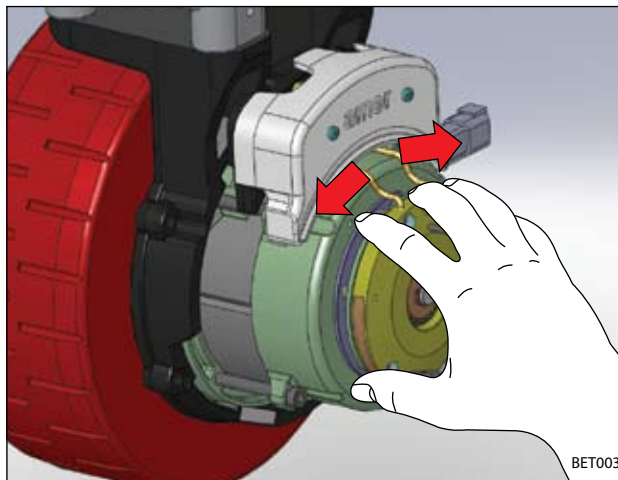

4. Slide the brake assembly off the splined shaft

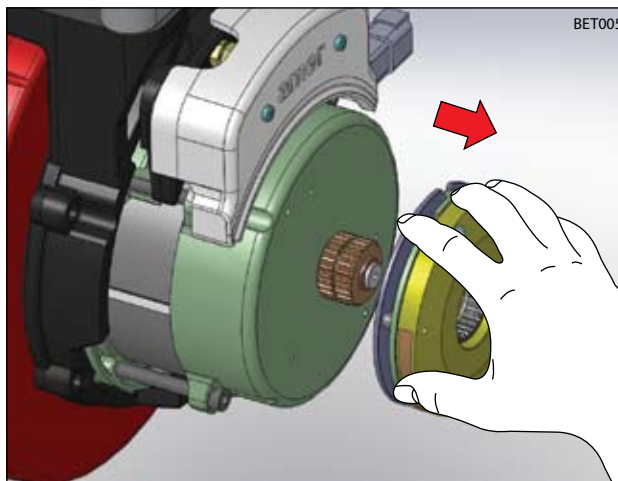

- Remove three flat head screws to disassemble the brake assembly.

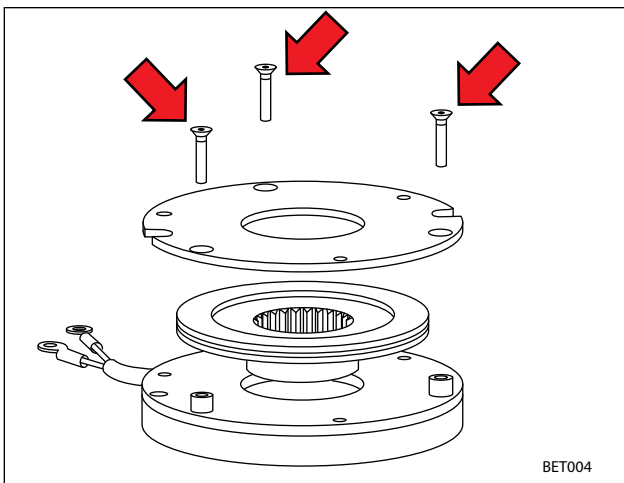

- Reassemble the brake assembly and slide it back onto the splined shaft.

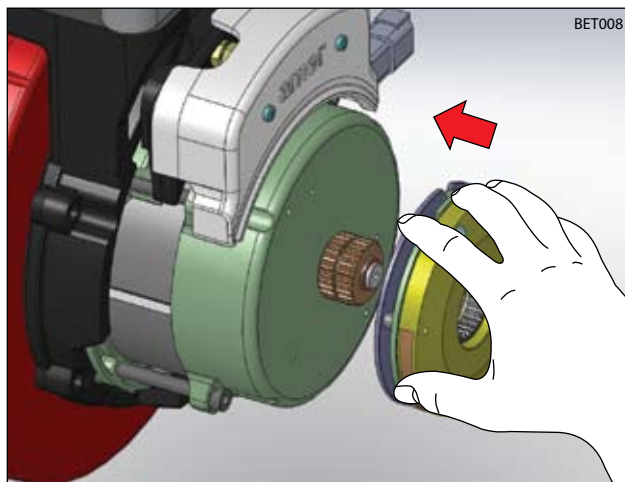

- Measure the thickness of the brake rotor using a vernier caliper. Replace the rotor if it is less than 4.4mm (0.17in) thickness.

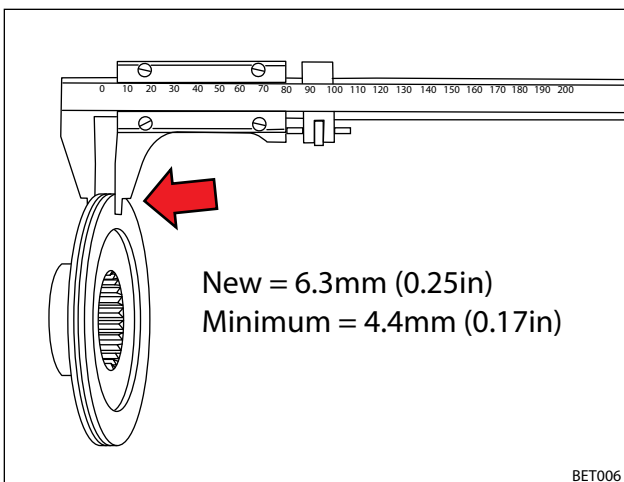

- Remove connection box cover screws and set cover aside.

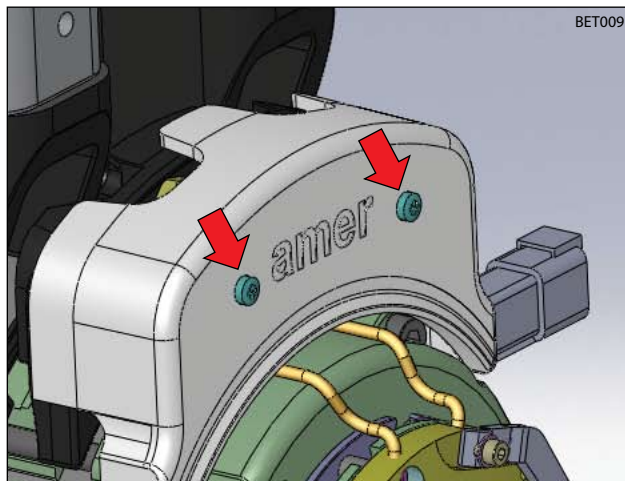

SERVICE

9. Remove brake wires from the B1 and B2 terminals in the connection box.

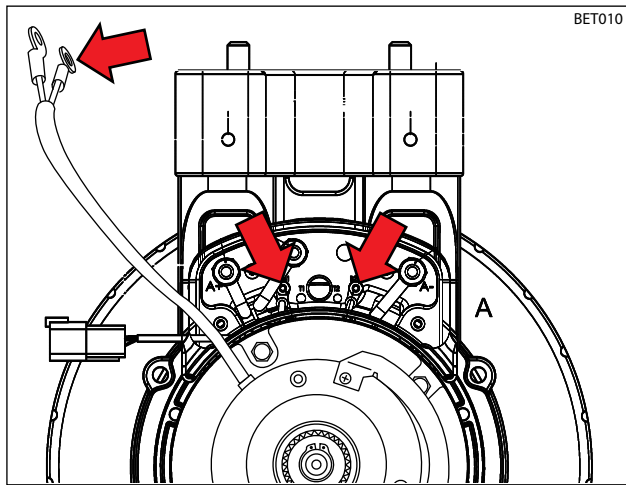

10. Test the resistance of the brake coil using an ohmmeter as shown below. The resistance should be approximately 50-60 Ohms.

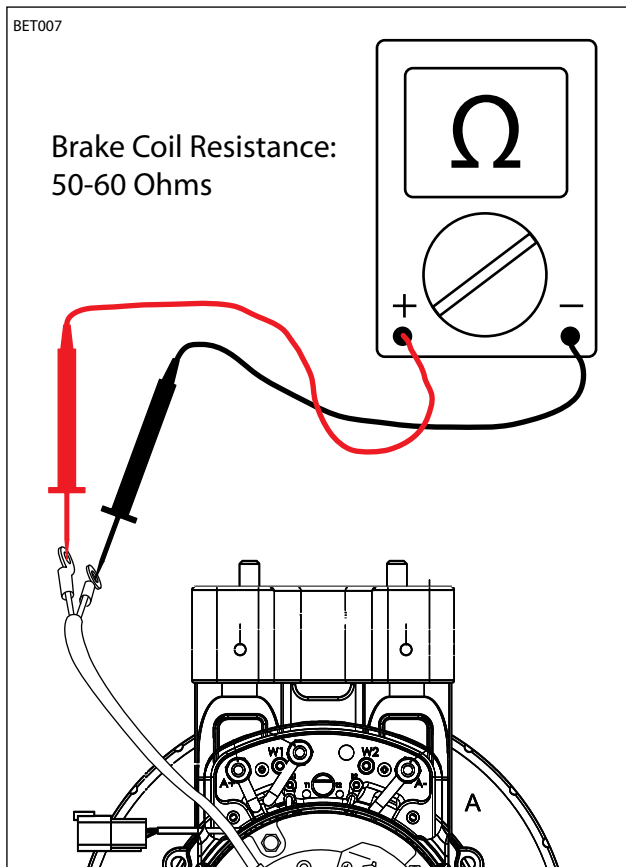

11. Apply battery voltage to the brake assembly using fuse-protected jumper leads as shown below. The brake energizes to release. Attempt to manually rotate the brake assembly while battery voltage is applied. Replace the brake assembly if it DOES NOT rotate freely on the splined shaft.

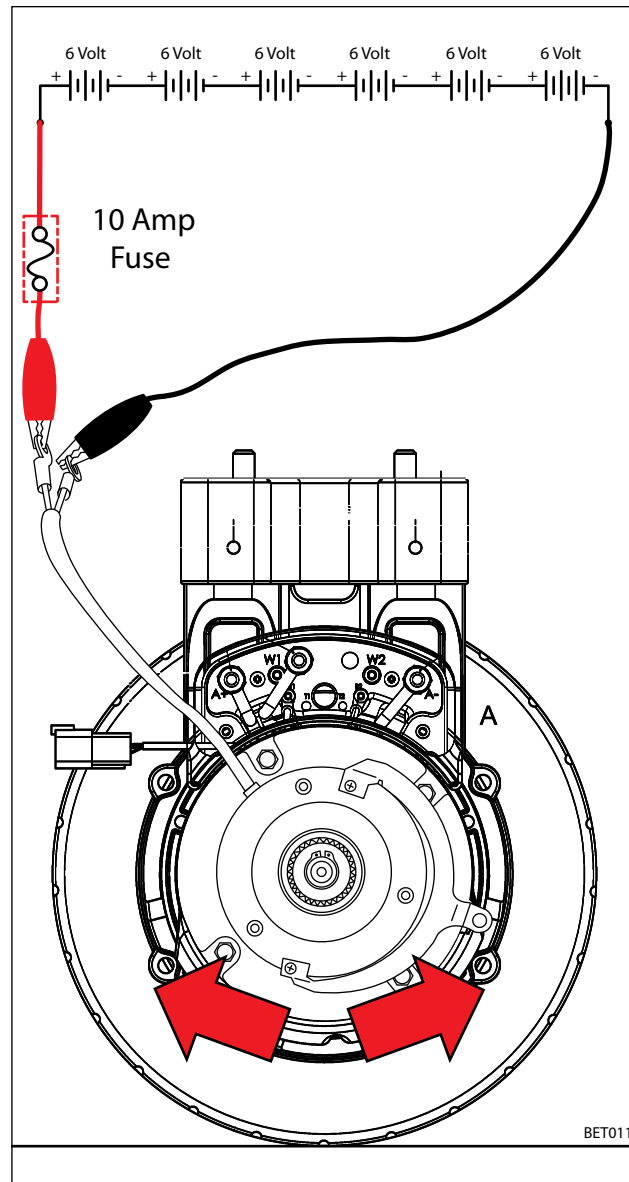

12. Clean and inspect the brake assembly as required.

TESTING PROPEL MOTOR

FOR SAFETY: Before leaving or servicing machine, stop on level surface, turn off machine and remove key.

FOR SAFETY: When servicing machine, disconnect battery connection before working on machine.

1. Key Off. Remove terminal box cover screws and set cover aside.

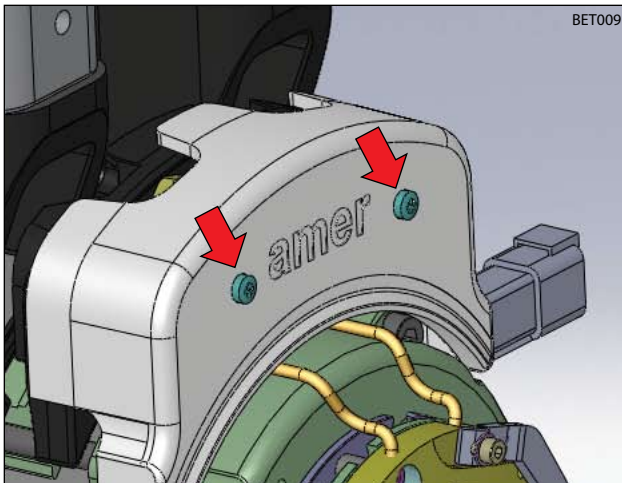

2. Disconnect U, V, and W cables from W1, A-, and A+ terminals (respectively).

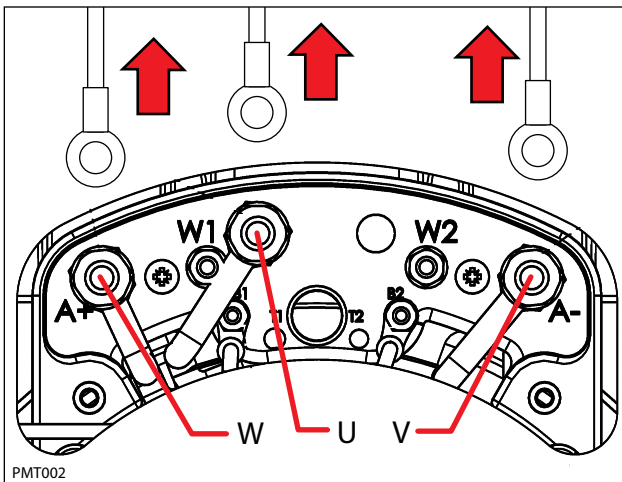

3. Test the resistance of all three motor windings using an ohmmeter as shown below. The resistances of each winding should be within 5% of each other. An open or shorted winding indicates a faulty motor.

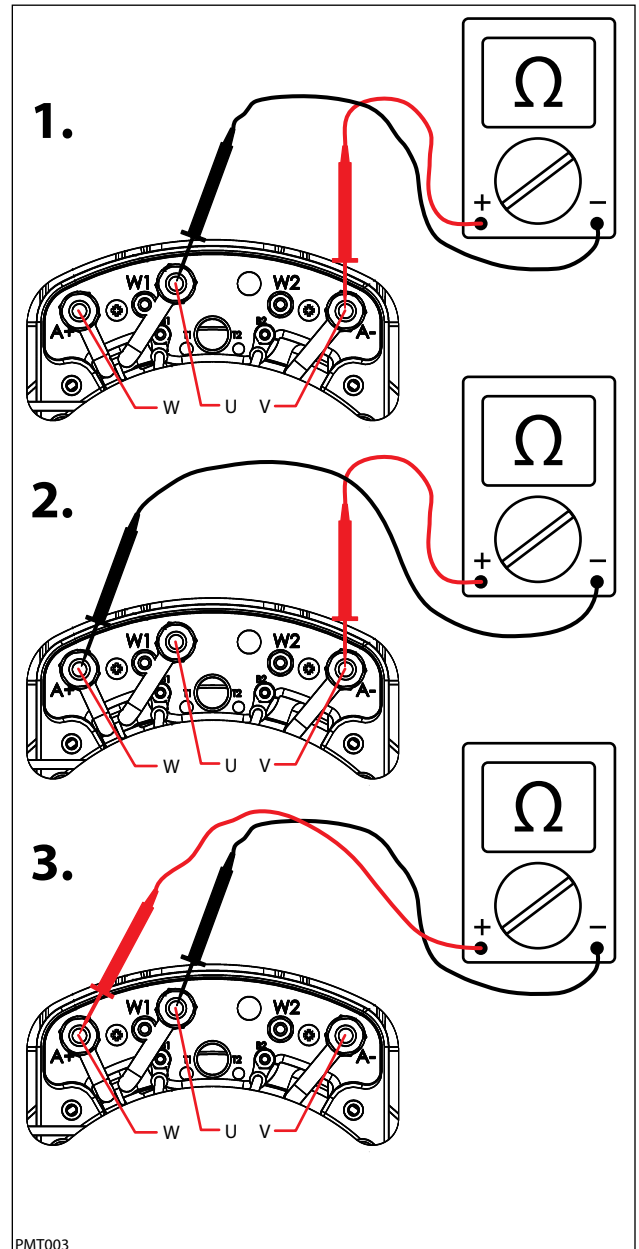

SERVICE

4. Test the resistance between all three motor terminals and the motor case as shown below. The ohmmeter should read "O.L." or open. A shorted winding indicates a faulty motor.

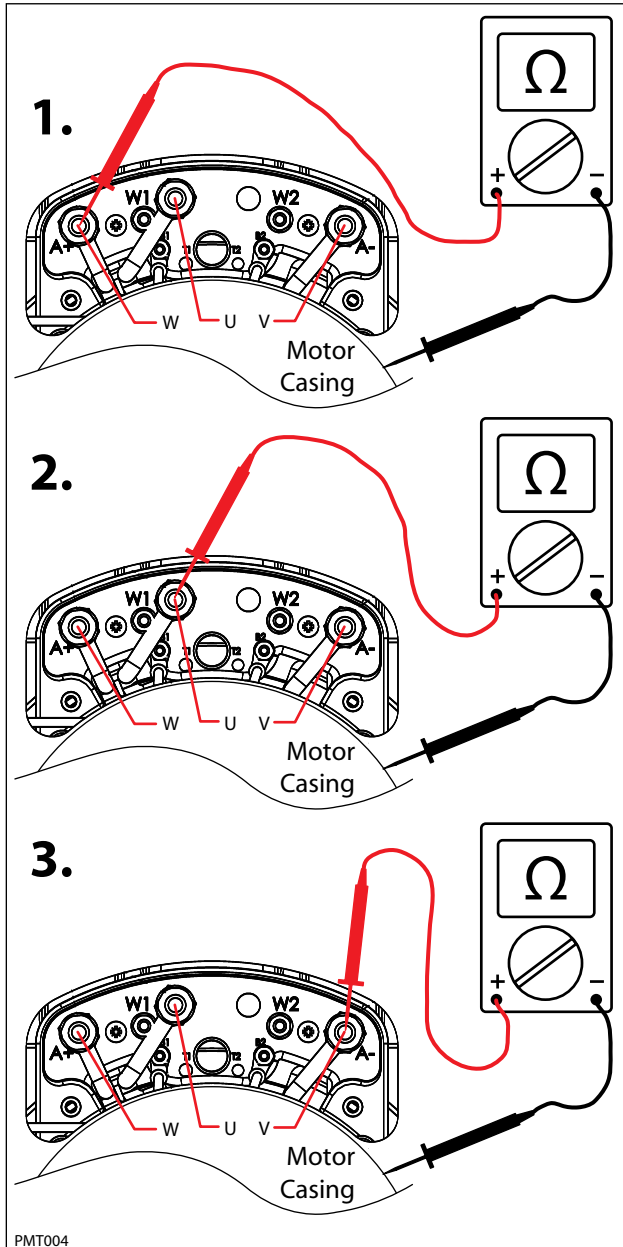

5. The motor encoder and temperature sender are non-serviceable components of the drive motor. The motor encoder senses rotor position, speed, and direction. The encoder is integrated into an internal roller bearing assembly. See "Curtis 1234 LED Faults" in the TROUBLESHOOTING section for encoder related faults.

The temperature sender senses the propel motor temperature. Test the resistance of the temperature sender using an ohmmeter and then compare the values to the chart below. Replace the motor assembly if the resistance values are out of the specified range.

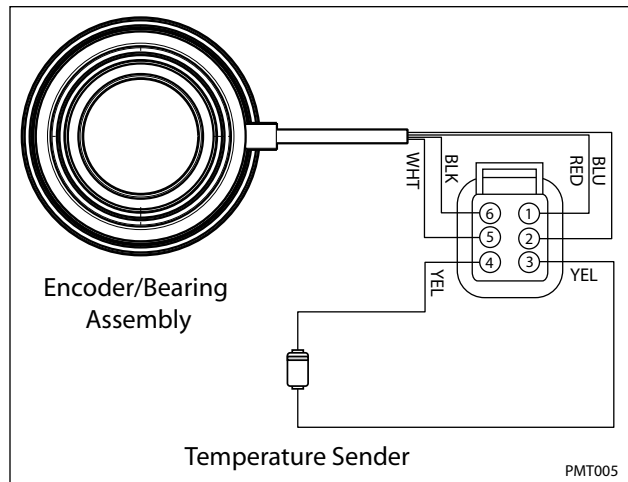

| TEMPERATURE | | RESISTANCE (Ω) | | |
|-----------------|-----------------|-------------------------|------|------|
| ($^{\circ}$ C) | ($^{\circ}$ F) | MIN. | TYP. | MAX |
| -30 | -22 | 362 | 381 | 368 |
| 0 | 32 | 464 | 486 | 507 |
| 25 | 77 | 565 | 588 | 611 |
| 30 | 86 | 587 | 610 | 633 |
| 50 | 122 | 679 | 704 | 728 |
| 70 | 158 | 781 | 806 | 831 |
| 80 | 176 | 835 | 860 | 885 |
| 100 | 212 | 950 | 975 | 1000 |
| 110 | 230 | 1007 | 1036 | 1064 |

TESTING PROPEL MOTOR CABLES

FOR SAFETY: Before leaving or servicing machine, stop on level surface, turn off machine and remove key.

FOR SAFETY: When servicing machine, disconnect battery connection before working on machine.

1. Key Off. Disconnect batteries. Remove terminal box cover screws and set cover aside.

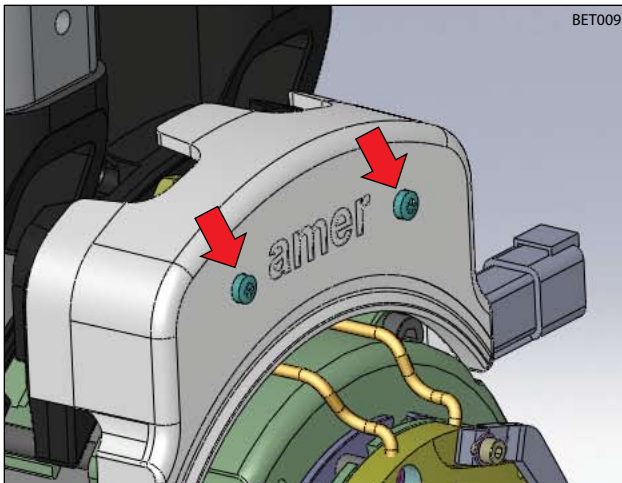

2. Disconnect U, V, and W cables from W1, A-, and A+ terminals (respectively).

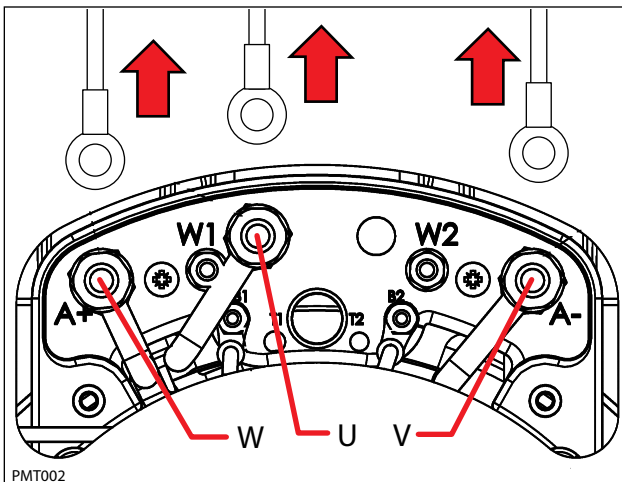

3. Disconnect U, V, and W cables from Curtis 1234 controller as shown below.

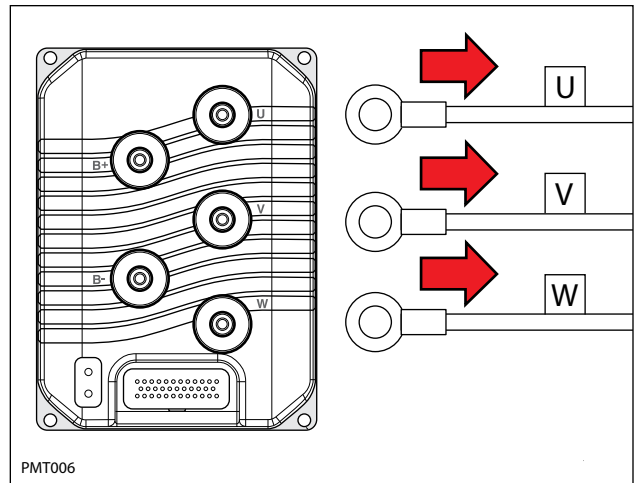

4. Reconnect battery connection and test each cable using an Ohmmeter for a short to battery + as shown below. Each cable should test as "O.L." or open to battery +. Replace shorted cable(s).

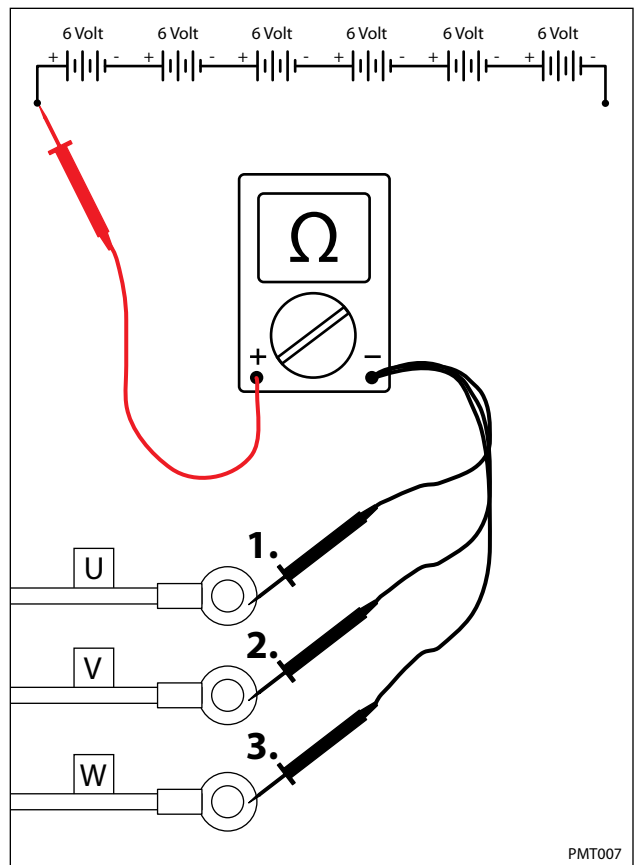

SERVICE

5. Test each cable using an ohmmeter for a short to battery - as shown below. Each cable should test as "O.L." or open to battery -. Replace shorted cable(s).

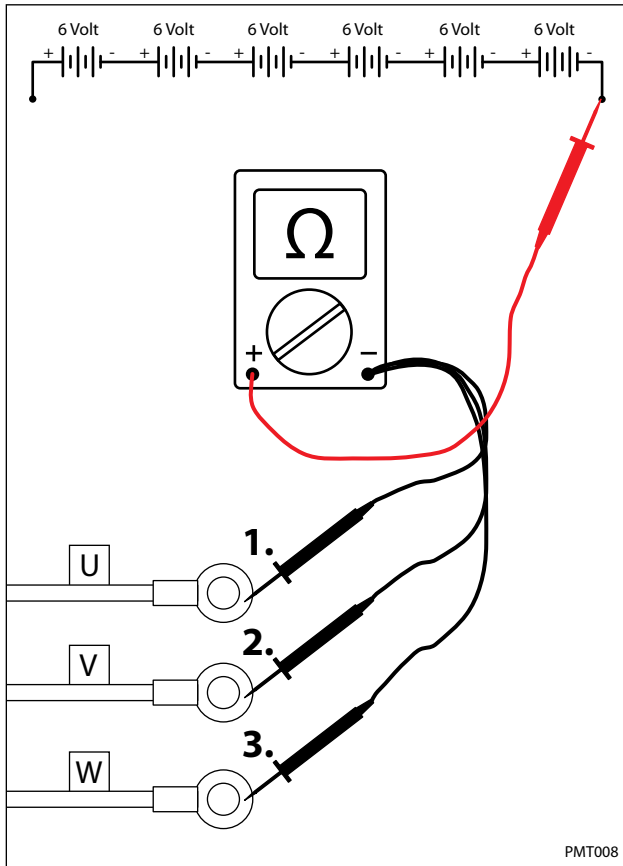

6. Test each cable using an ohmmeter for a short to chassis as shown below. Each cable should test as "O.L." or open to chassis. Replace shorted cable(s).

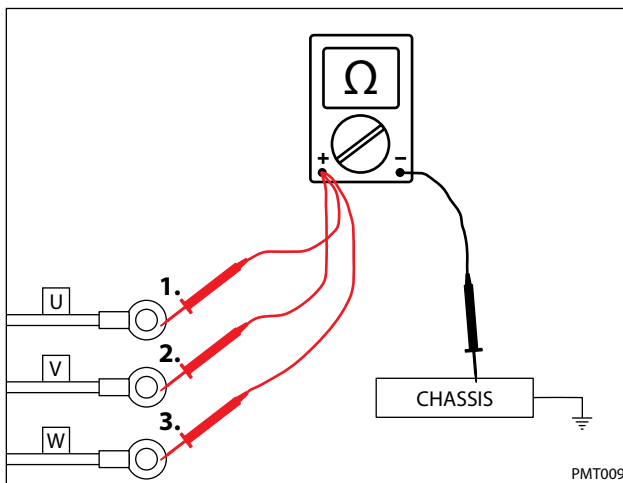

7. Test each cable using an ohmmeter for end-to-end continuity. Each cable should test between 0-1 ohm resistance. Replace open cable(s).

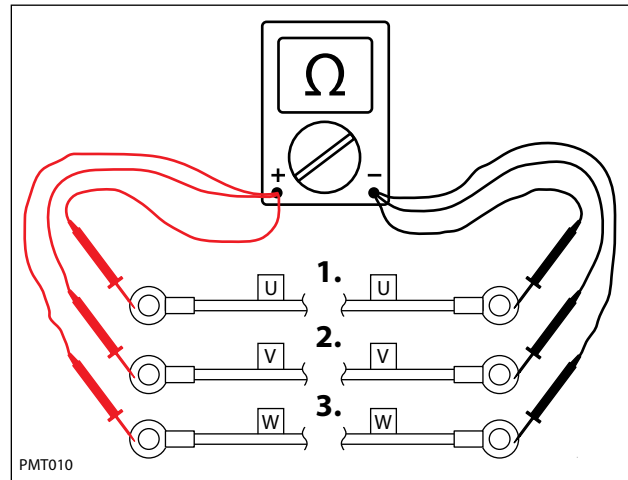

8. "Tug test" each cable (motor end) to determine if a cable is broken inside the insulation. Do not exceed 10 lbs (45 N) of force as cable damage may occur. Replace broken cables.

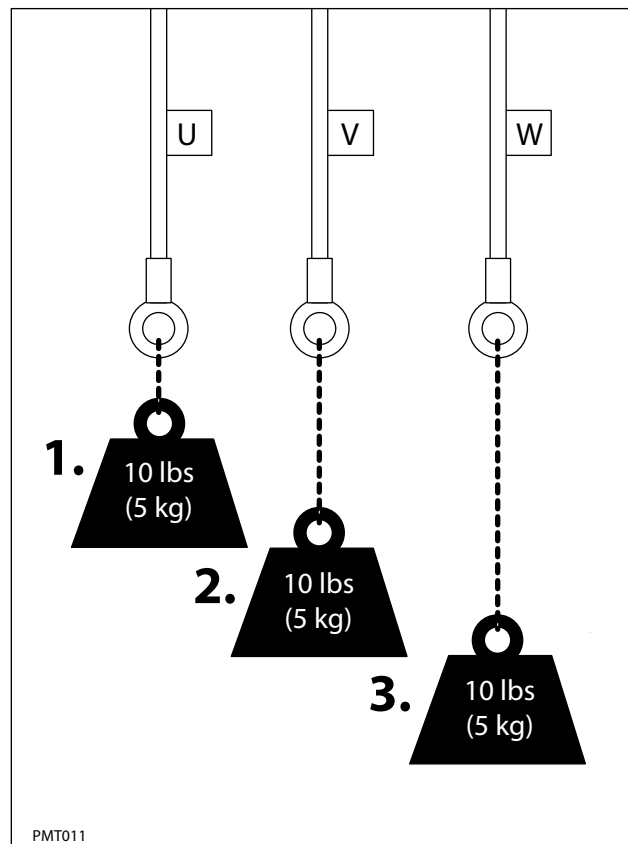

TESTING THROTTLE/BRAKE SENSOR

FOR SAFETY: Before leaving or servicing machine, stop on level surface.

FOR SAFETY: When servicing machine, jack machine up at designated locations only. Block machine up with jack stands.

FOR SAFETY: When servicing machine, avoid moving parts. Do not wear loose jackets, shirts, or sleeves when working on machine .

1. Jack machine up so front drive wheel is not touching the floor. Block machine up with jack stands.
2. The throttle and brake hall effect sensor is a component of the pedal subassembly.

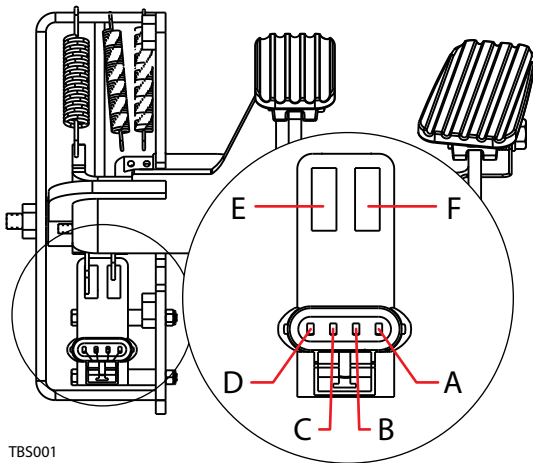

TBS001

3. Key On. Backprobe the power supply to the throttle/ brake sensor terminals A and D using a voltmeter as shown below. The voltmeter should display battery voltage.

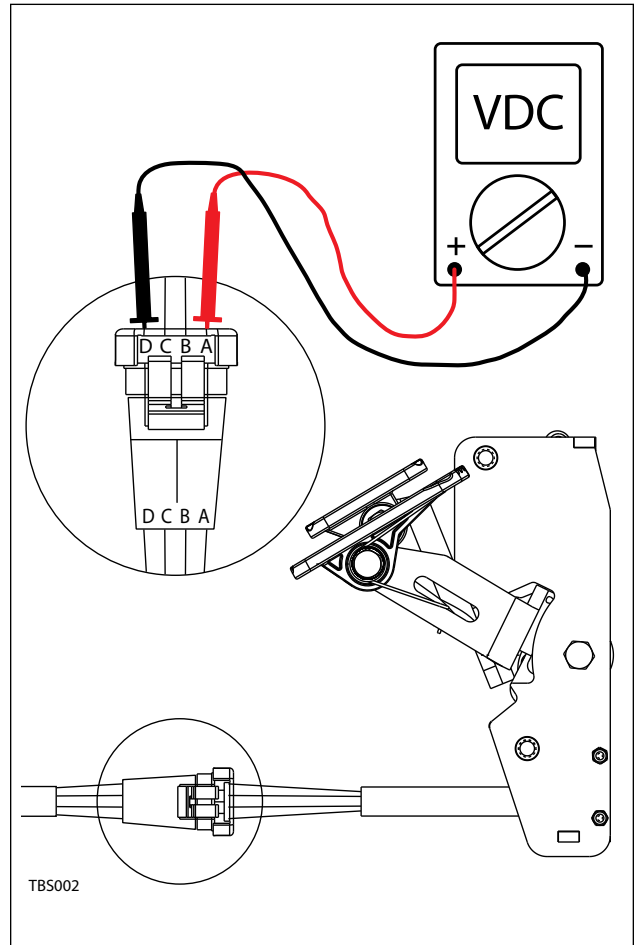

TBS002

| PIN/CAVITY | NOTES | COLOR |
|------------|-------------------------|--------|
| A | POWER (BATTERY +) | RED |
| B | FORWARD OUTPUT (0-5Vdc) | YELLOW |
| C | BRAKE (0-5Vdc) | BLUE |
| D | GROUND (BATTERY -) | BLACK |
| E | GATE A | N/A |
| F | GATE B | N/A |

SERVICE

4. Key On. Backprobe the throttle sensor output terminals B and D using a voltmeter as shown below. The voltmeter should display 0-5 volts proportional to 0-100% propel pedal movement.

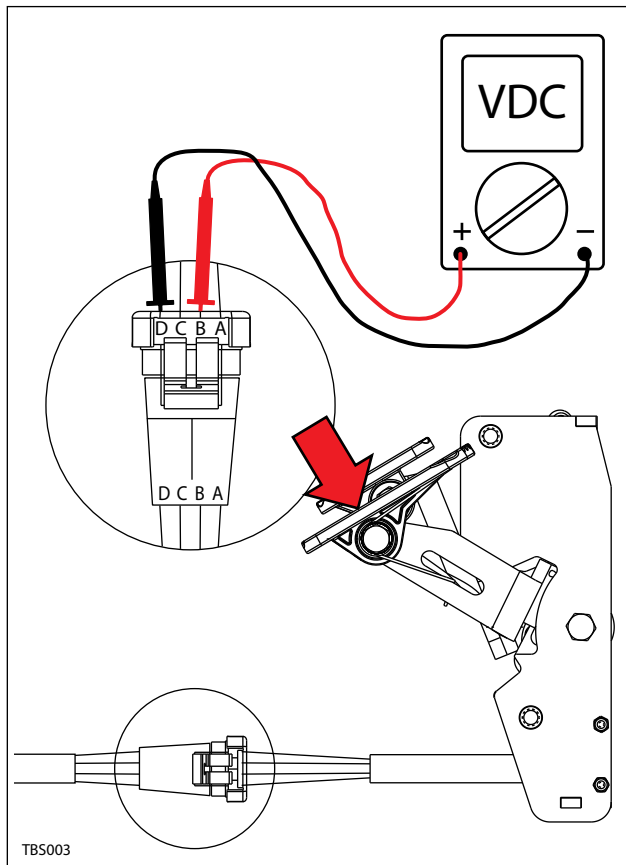

6. Key On. Backprobe the brake sensor terminals C and D using a voltmeter as shown below. The voltmeter should display 5 volts when the brake pedal is activated.

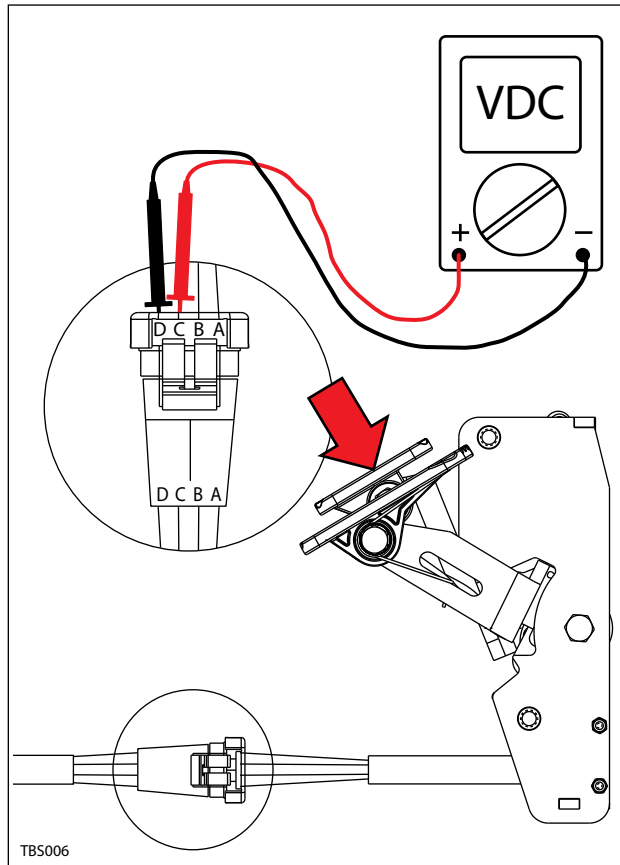

5. See "Propel Diagnostic Mode" in the TROUBLE SHOOTING section. The voltage in step 3 should match the LCD displayed voltage in Propel Diagnostic Mode.

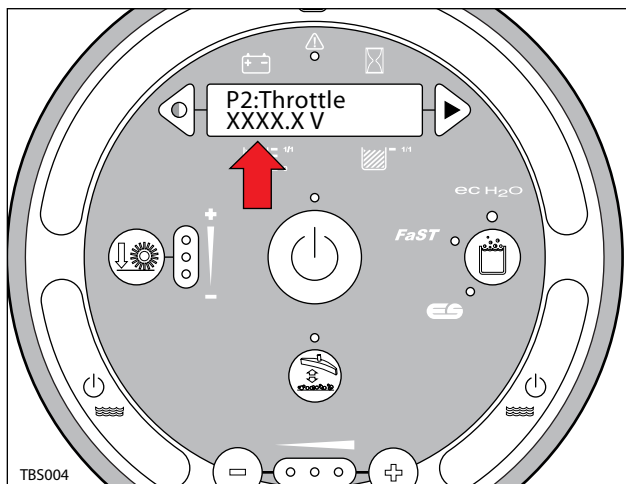

7. See "Propel Diagnostic Mode" in the TROUBLE SHOOTING section. The change in voltage in step 5 should correspond to a brake pedal "On" or "Off" LCD message.

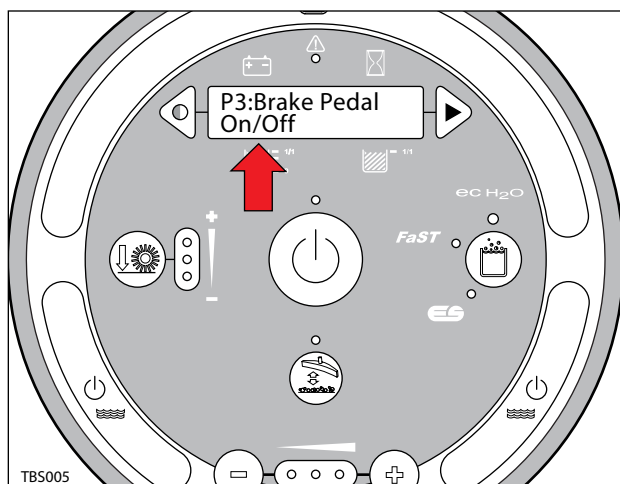

TESTING PRE-SWEEP LIFT ACTUATOR

FOR SAFETY: Before leaving or servicing machine, stop on level surface, turn off machine and remove key.

FOR SAFETY: When servicing machine, disconnect battery connection before working on machine.

FOR SAFETY: When servicing machine, avoid moving parts. Do not wear loose jackets, shirts, or sleeves when working on machine.

1. Key Off. Disconnect the Pre-Sweep lift actuator from the wire harness.

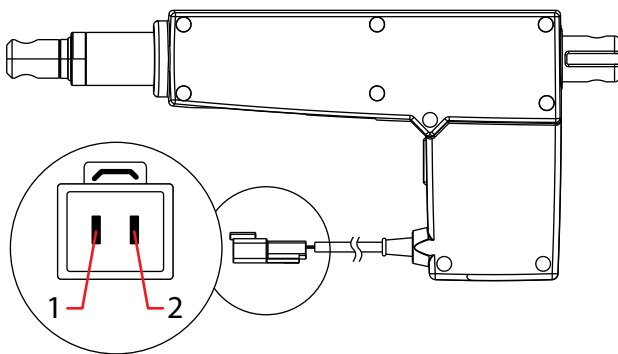

PSLA001

| PIN ASSIGNMENT | |
|----------------|-------|
| 2 | BLUE |
| 1 | BROWN |

2. Apply battery voltage to the lift actuator using fuse-protected jumper leads as shown below. Be sure to connect battery + to terminal 1 and battery - to terminal 2. The actuator should extend completely and then turn Off when the extend limit switch opens. Replace the actuator if it fails to extend.

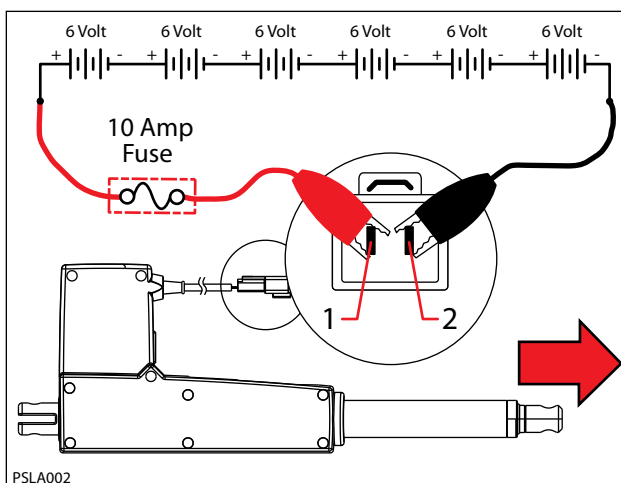

PSLA002

3. Reverse polarity and apply battery voltage to the lift actuator using fuse-protected jumper leads as shown below. Connect battery - to terminal 1 and battery + to terminal 2. The actuator should retract completely and then turn Off when the retract limit switch opens. Replace the actuator if it fails to retract.

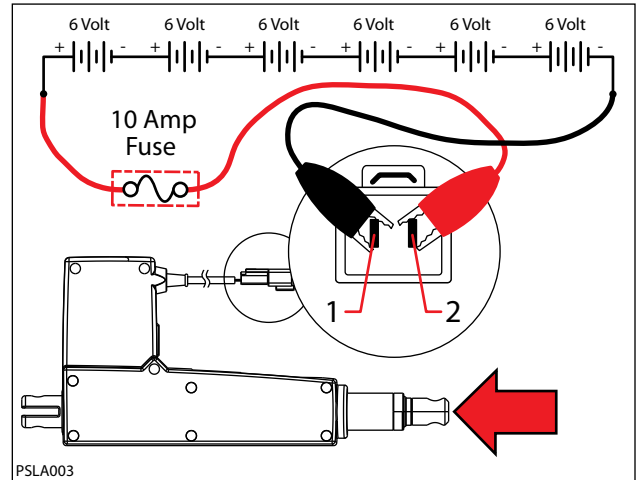

PSLA003

SERVICE

TESTING SIDE BRUSH LIFT ACTUATOR

FOR SAFETY: Before leaving or servicing machine, stop on level surface, turn off machine and remove key.

FOR SAFETY: When servicing machine, disconnect battery connection before working on machine.

FOR SAFETY: When servicing machine, avoid moving parts. Do not wear loose jackets, shirts, or sleeves when working on machine .

1. Key Off. Disconnect the Pre-Sweep lift actuator from the wire harness.

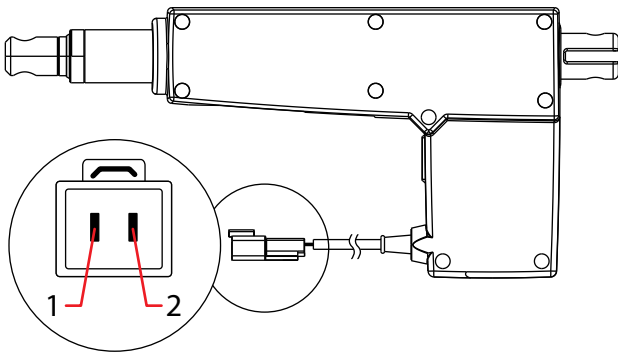

PSLA001

| PIN ASSIGNMENT | |
|----------------|-------|
| 2 | BLUE |
| 1 | BROWN |

2. Apply battery voltage to the lift actuator using fuse-protected jumper leads as shown below. Be sure to connect battery + to terminal 1 and battery - to terminal 2. The actuator should extend completely and then turn Off when the extend limit switch opens. Replace the actuator if it fails to extend.

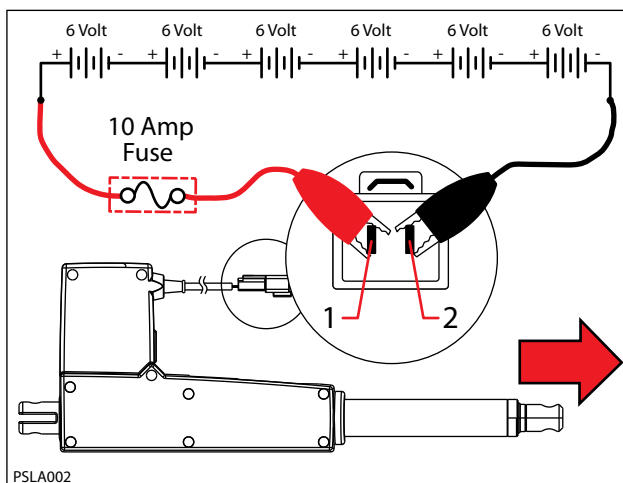

PSLA002

3. Reverse polarity and apply battery voltage to the lift actuator using fuse-protected jumper leads as shown below. Connect battery - to terminal 1 and battery + to terminal 2. The actuator should retract completely and then turn Off when the retract limit switch opens. Replace the actuator if it fails to retract.

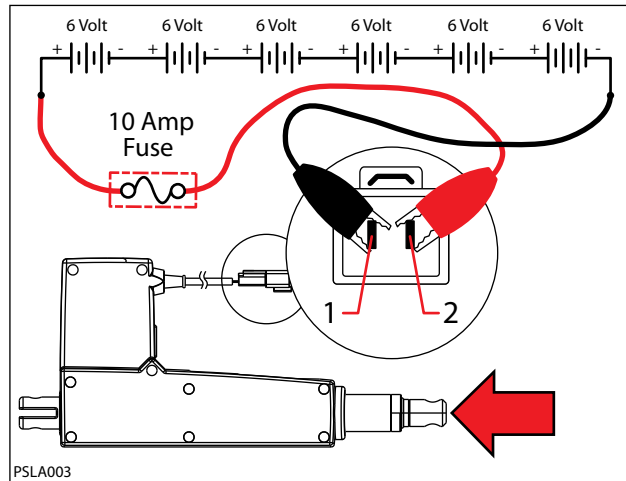

PSLA003

TESTING MAIN BRUSH LIFT ACTUATOR

FOR SAFETY: Before leaving or servicing machine, stop on level surface, turn off machine and remove key.

FOR SAFETY: When servicing machine, disconnect battery connection before working on machine.

FOR SAFETY: When servicing machine, avoid moving parts. Do not wear loose jackets, shirts, or sleeves when working on machine.

1. Key Off. Disconnect the main brush lift actuator from the wire harness.

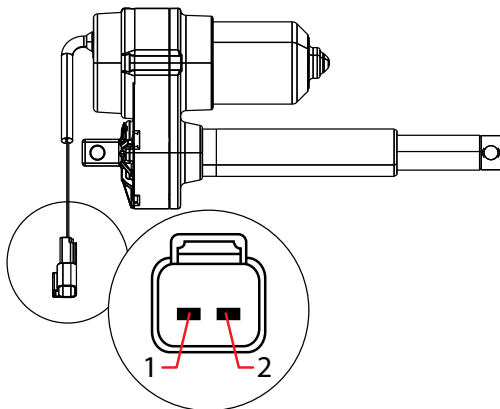

MSLA001

| PIN ASSIGNMENT | |
|----------------|-------|
| 2 | BLACK |
| 1 | RED |

2. Apply battery voltage to the lift actuator using fuse-protected jumper leads as shown below. Be sure to connect battery + to terminal 1 and battery - to terminal 2. The actuator should retract completely. Replace the actuator if it fails to retract.

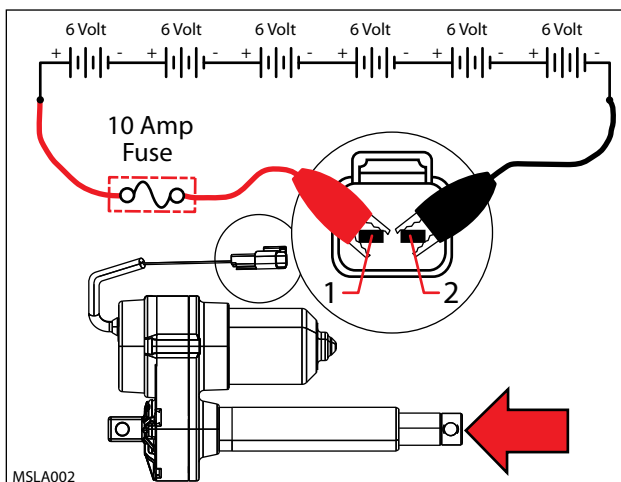

MSLA002

3. Reverse polarity and apply battery voltage to the lift actuator using fuse-protected jumper leads as shown below. Connect battery - to terminal 1 and battery + to terminal 2. The actuator should extend completely. Replace the actuator if it fails to extend.

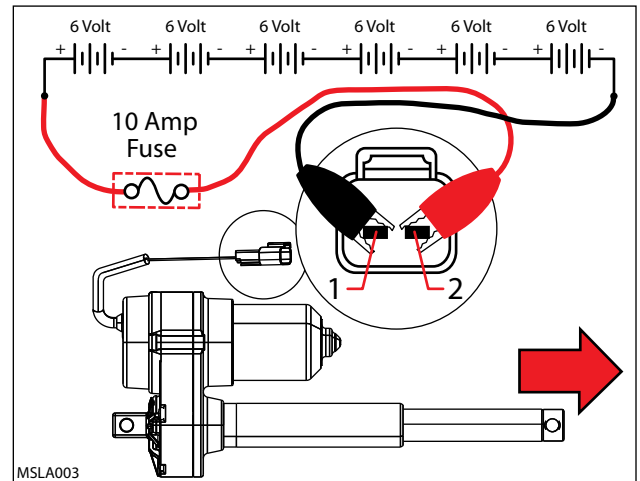

MSLA003

SERVICE

TESTING REAR SQUEEGEE LIFT ACTUATOR

FOR SAFETY: Before leaving or servicing machine, stop on level surface, turn off machine and remove key.

FOR SAFETY: When servicing machine, disconnect battery connection before working on machine.

FOR SAFETY: When servicing machine, avoid moving parts. Do not wear loose jackets, shirts, or sleeves when working on machine.

1. Key Off. Disconnect the rear squeegee lift actuator from the wire harness.

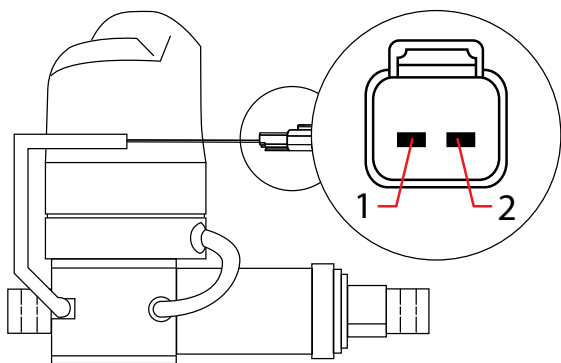

RSLA001

| PIN ASSIGNMENT | |
|----------------|-------|
| 2 | BLACK |
| 1 | BLACK |

2. Apply battery voltage to the lift actuator using fuse-protected jumper leads as shown below. Be sure to connect battery + to terminal 1 and battery - to terminal 2. The actuator should retract completely. Replace the actuator if it fails to retract.

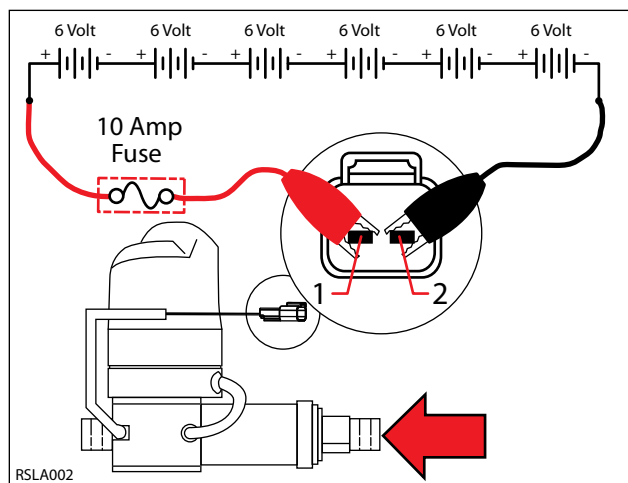

RSLA002

3. Reverse polarity and apply battery voltage to the lift actuator using fuse-protected jumper leads as shown below. Connect battery - to terminal 1 and battery + to terminal 2. The actuator should extend completely. Replace the actuator if it fails to extend.

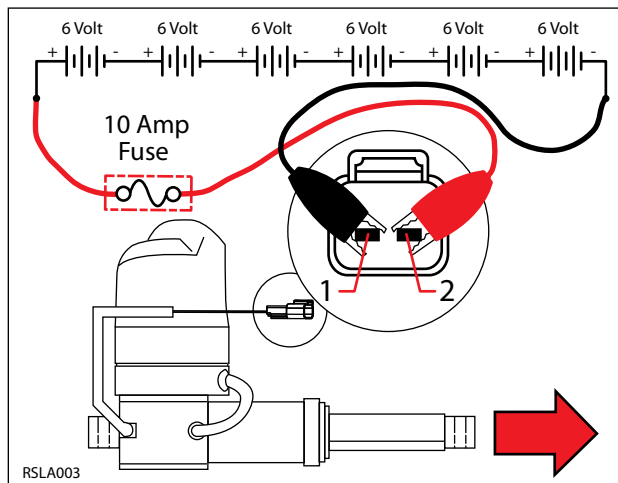

RSLA003

TESTING VACUUM FAN(S) (SCRUBBING)

FOR SAFETY: Before leaving or servicing machine, stop on level surface, turn off machine and remove key.

FOR SAFETY: When servicing machine, disconnect battery connection before working on machine.

NOTE: Optional dual vacuum fans shown.

1. Key Off. Disconnect vacuum fan(s) from wire harness.

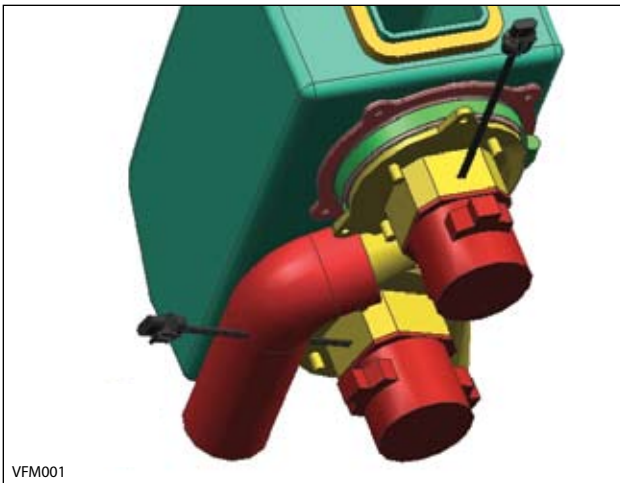

2. Key Off. Inspect carbon brushes. Replace carbon brushes if they are shorter than 10mm (0.375 in).

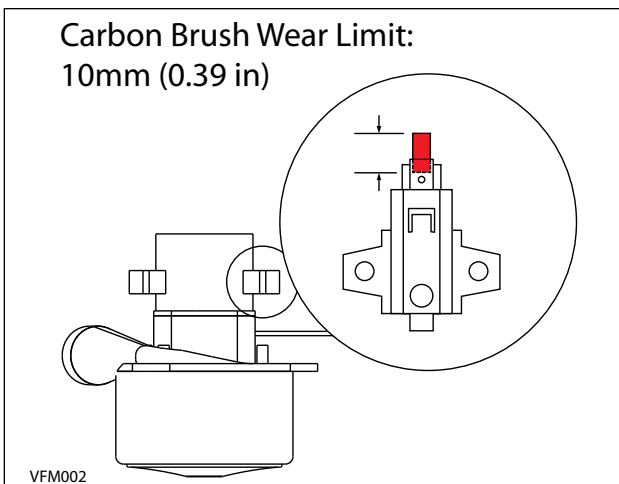

3. Apply battery voltage to the vacuum fan(s) using fuse-protected jumper leads as shown below. The fan should turn On. Replace the vacuum fan if it fails to turn On.

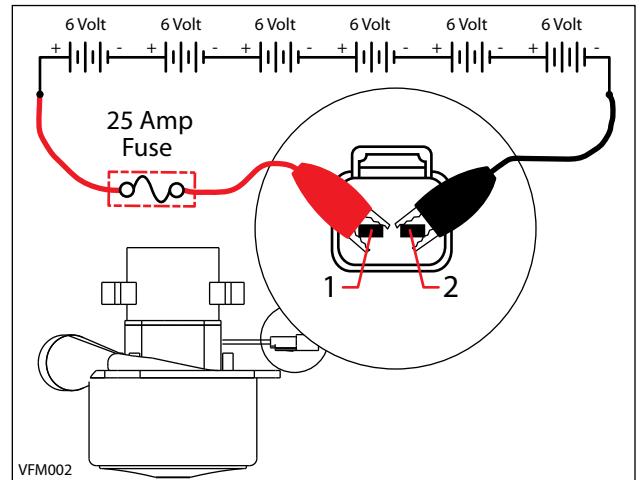

4. Reconnect vacuum fan(s) to wire harness. See "Manual Mode" in the TROUBLESHOOTING section. Activate the vacuum fan(s) in Manual Mode. The amperage displayed should be approximately 14-20 Amps.

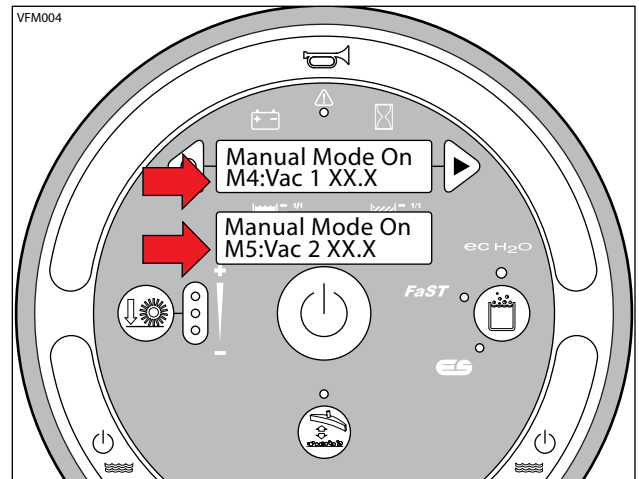

SERVICE

TESTING VACUUM FAN (PRE-SWEEP)

FOR SAFETY: Before leaving or servicing machine, stop on level surface, turn off machine and remove key.

FOR SAFETY: When servicing machine, disconnect battery connection before working on machine.

1. Disconnect vacuum fan from wire harness. Inspect carbon brushes. Replace carbon brushes if they are shorter than 10mm (0.375 in).

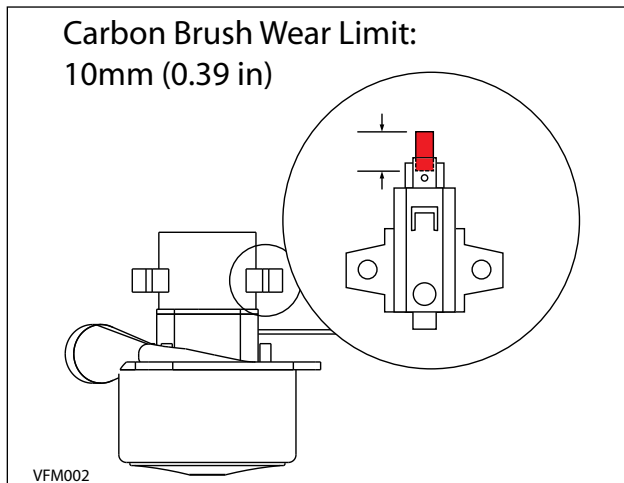

2. Apply battery voltage to the vacuum fan using fuse-protected jumper leads as shown below. The fan should turn On. Replace the vacuum fan if it fails to turn On.

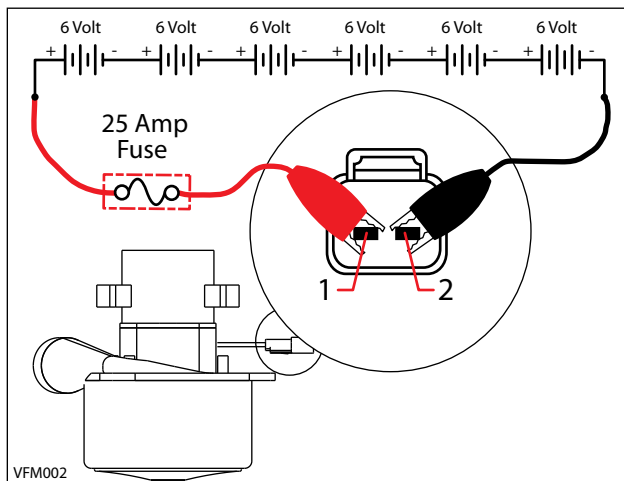

TESTING MAIN SCRUB BRUSH MOTOR(S)

FOR SAFETY: Before leaving or servicing machine, stop on level surface, turn off machine and remove key.

FOR SAFETY: When servicing machine, disconnect battery connection before working on machine.

1. Key Off. Disconnect the main brush motor from the wire harness.

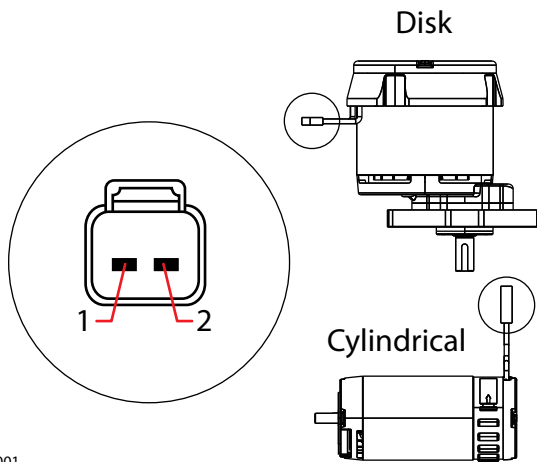

MBM001

| PIN ASSIGNMENT | |
|----------------|-------|
| 2 | BLACK |
| 1 | RED |

2. Inspect carbon brushes. Replace carbon brushes if they are shorter than; Disk = 11mm (0.43 in), Cylindrical = 10mm (0.39 in).

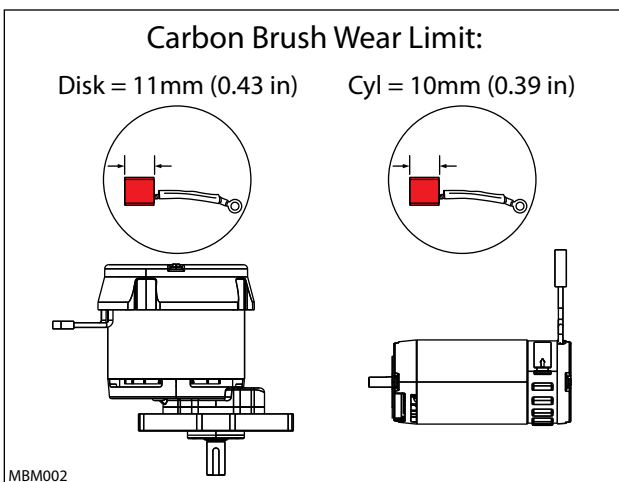

MBM002

3. Apply battery voltage to the main brush motor(s) using fuse-protected jumper leads as shown below. The brush motor should turn On. Replace the brush motor if it fails to turn On.

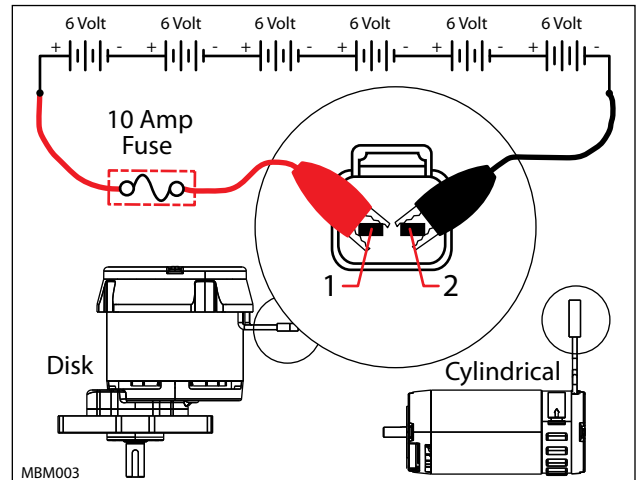

MBM003

SERVICE

TESTING MAIN SWEEP BROOM MOTOR

FOR SAFETY: Before leaving or servicing machine, stop on level surface, turn off machine and remove key.

FOR SAFETY: When servicing machine, disconnect battery connection before working on machine.

1. Key Off. Disconnect the main sweep brush motor from the wire harness.

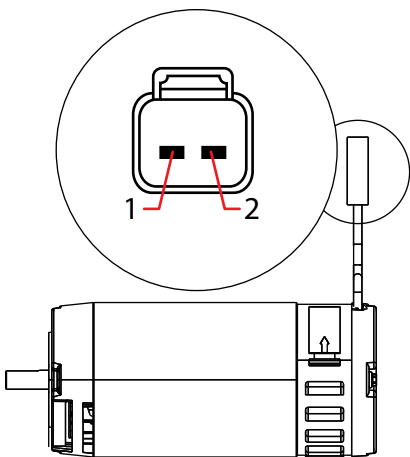

MSBM001

| PIN ASSIGNMENT | |
|----------------|-------|
| 2 | BLACK |
| 1 | RED |

2. Inspect carbon brushes. Replace carbon brushes if they are shorter than 10mm (0.39 in).

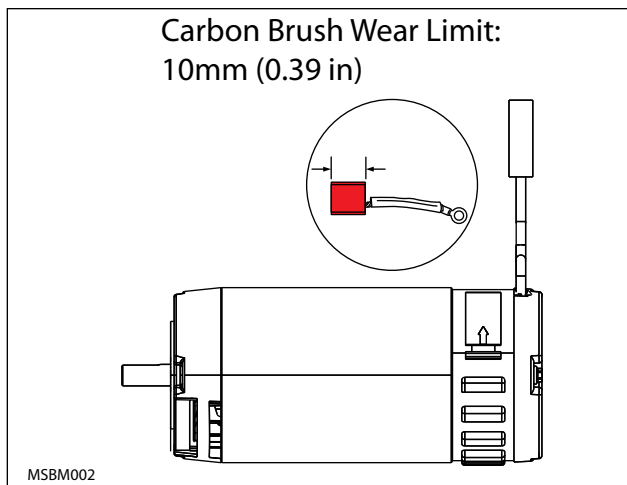

MSBM002

3. Apply battery voltage to the main sweep brush motor using fuse-protected jumper leads as shown below. The brush motor should turn On. Replace the brush motor if it fails to turn On.

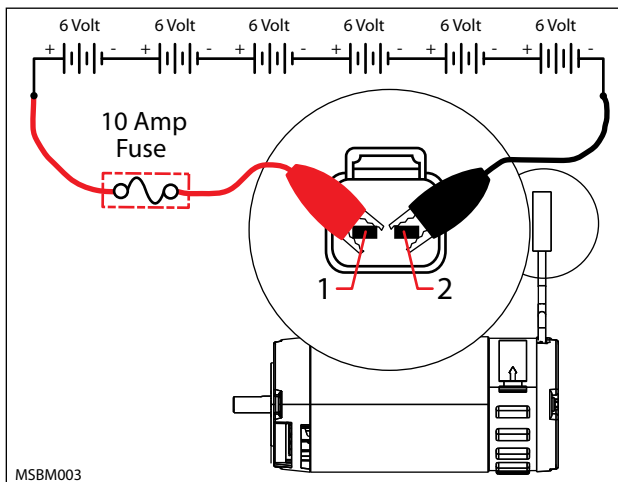

MSBM003

TESTING SIDE BRUSH MOTOR (NON PRE-SWEEP)

FOR SAFETY: Before leaving or servicing machine, stop on level surface, turn off machine and remove key.

FOR SAFETY: When servicing machine, disconnect battery connection before working on machine.

1. Key Off. Disconnect the side brush motor from the wire harness.

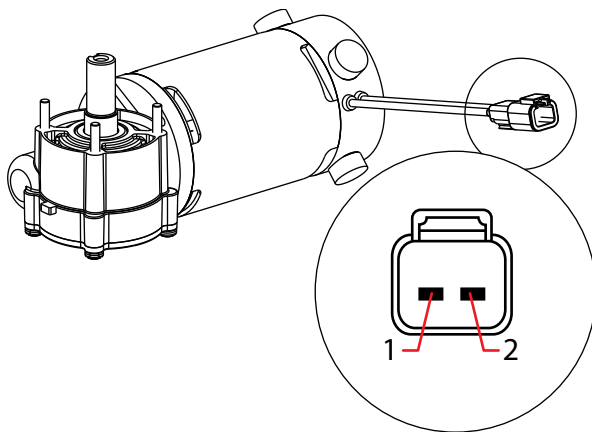

SBM001

| PIN ASSIGNMENT | |
|----------------|-------|
| 2 | BLACK |
| 1 | RED |

2. Key Off. Inspect carbon brushes. Replace carbon brushes if they are shorter than 10mm (0.375 in).

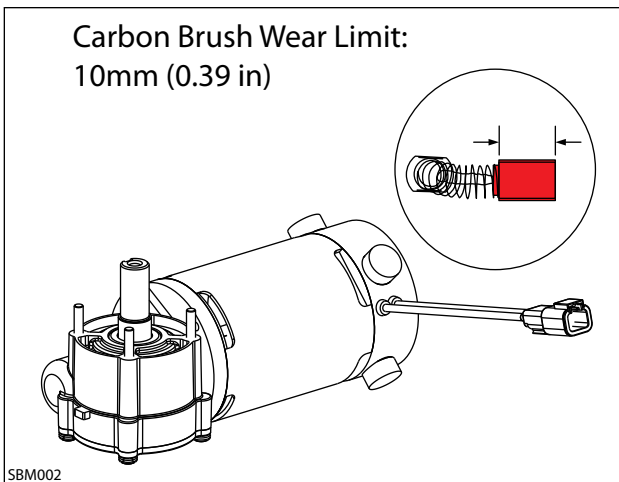

SBM002

3. Apply battery voltage to the side brush motor using fuse-protected jumper leads as shown below. The side brush motor should turn On. Replace the side brush motor if it fails to turn On.

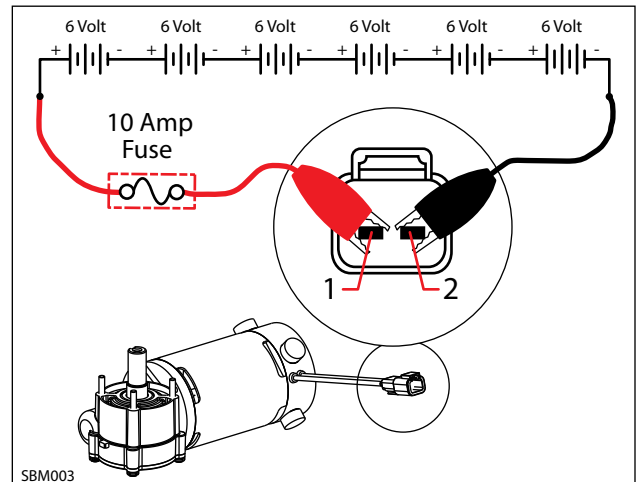

SBM003

SERVICE

TESTING SIDE BRUSH MOTOR(S) (PRE-SWEEP)

FOR SAFETY: Before leaving or servicing machine, stop on level surface, turn off machine and remove key.

FOR SAFETY: When servicing machine, disconnect battery connection before working on machine.

1. Key Off. Disconnect the Pre-Sweep side brush motor(s) from the wire harness.

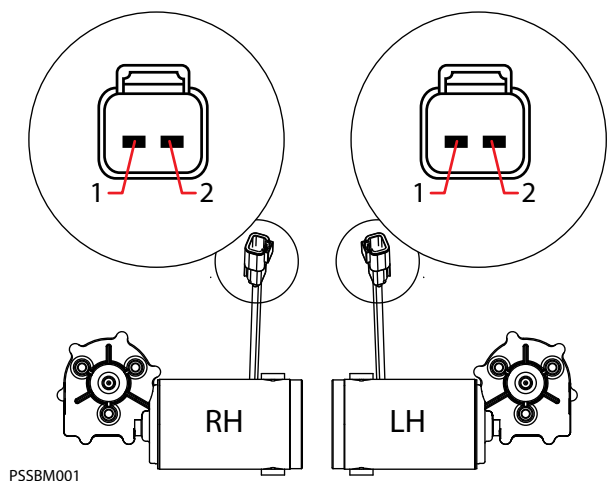

| PIN ASSIGNMENT | |
|----------------|-------|
| 2 | BLACK |
| 1 | RED |

2. Key Off. Inspect carbon brushes. Replace carbon brushes if they are shorter than 5mm (0.1875 in).

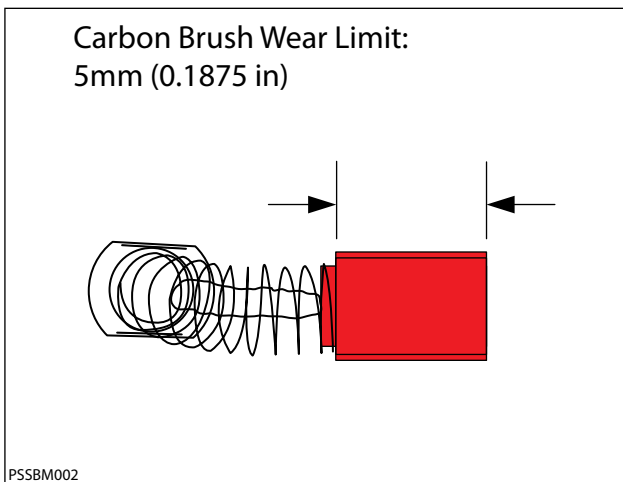

3. Apply battery voltage to the side brush motor(s) using fuse-protected jumper leads as shown below. The side brush motor(s) should turn On. Replace the side brush motor if it fails to turn On.

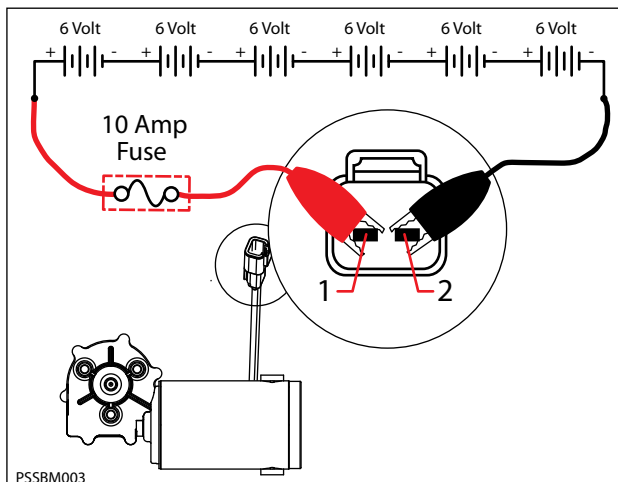

TESTING ec-H2O PUMP

FOR SAFETY: Before leaving or servicing machine, stop on level surface.

1. Key Off. Disconnect ec-H2O pump outlet hose.

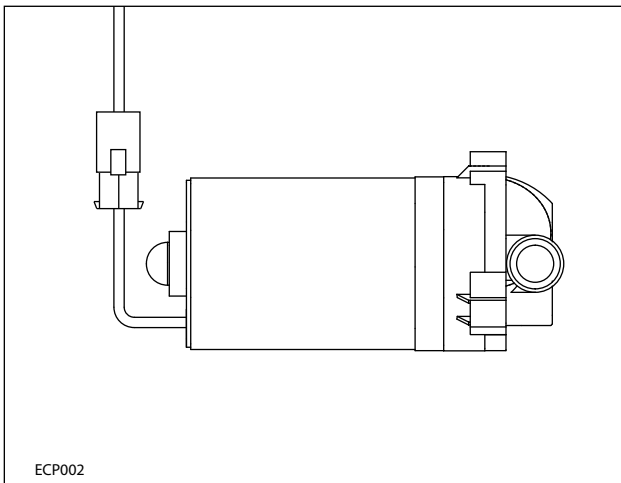

2. Fill the solution tank.
3. Connect a temporary outlet hose to the pump. The hose must be long enough to reach a 5 gallon bucket.

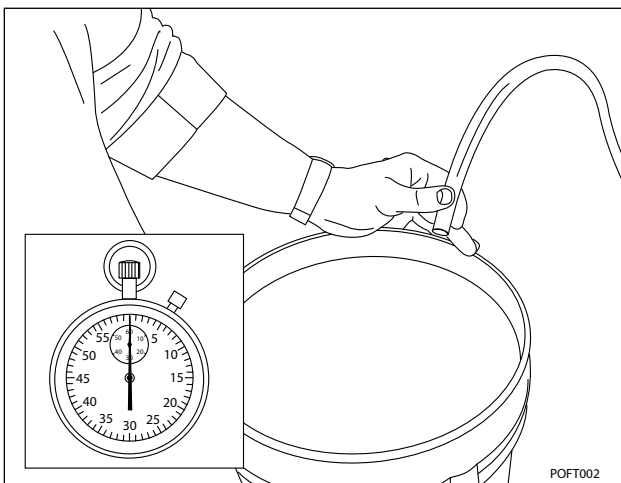

4. Enter Manual Mode and enable the ec-H2O system. See Manual Mode in the Troubleshooting section of this manual.

5. Use a stop watch to time how long it takes to fill a 5 gallon bucket. The open flow specification for the ec-H2O pump is 1.8 GPM. The pump should fill the 5 gallon bucket in approximately 2.5 - 3.0 minutes. Replace the pump if it takes longer than 3 minutes to fill and the pump has an adequate water supply.

NOTE: Open flow is different than system flow and should not be used for scrubbing mode water consumption calculations.

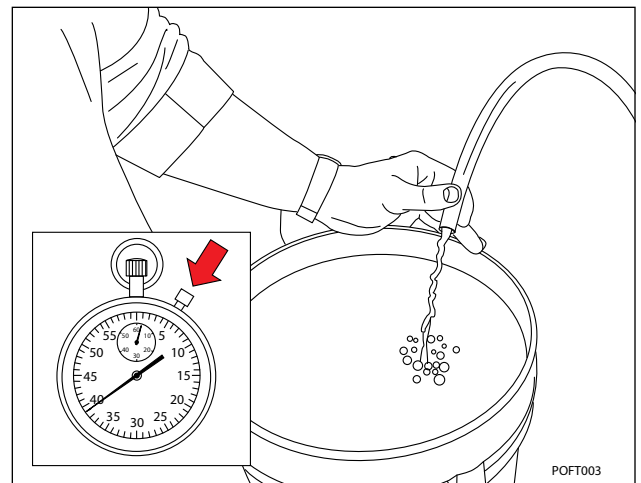

ADJUSTING ec-H2O FLOW RATE

DIP SWITCH SETTINGS

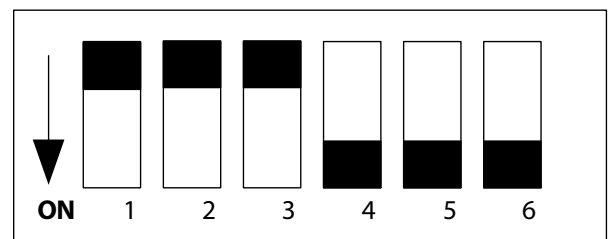

| TYPE | #1 | #2 | #3 | #4 | #5 | #6 |
|--------|-----|-----|-----|----|----|----|
| Low | OFF | OFF | OFF | ON | ON | ON |
| Medium | OFF | ON | OFF | ON | ON | ON |
| High | ON | OFF | OFF | ON | ON | ON |

NOTE: Low is the default setting for disk scrub heads. Medium is the default setting for cylindrical scrub heads.

SERVICE

TESTING ec-H2O PRESSURE SWITCH

FOR SAFETY: Before leaving or servicing machine, stop on level surface, turn off machine and remove key.

FOR SAFETY: When servicing machine, disconnect battery connection before working on machine.

1. Key Off. Disconnect the pressure switch from the wire harness and remove the switch from the machine.

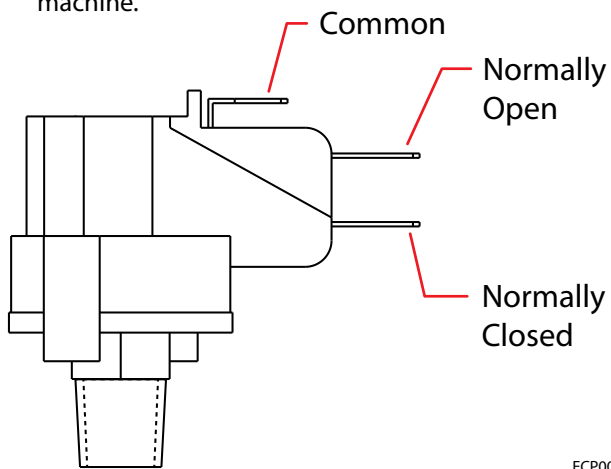

ECP001

2. Test the resistance of the switch using an ohmmeter between the common and normally closed terminals. There should be 0-1 ohms resistance. Replace the switch if the N.C. contacts are open.

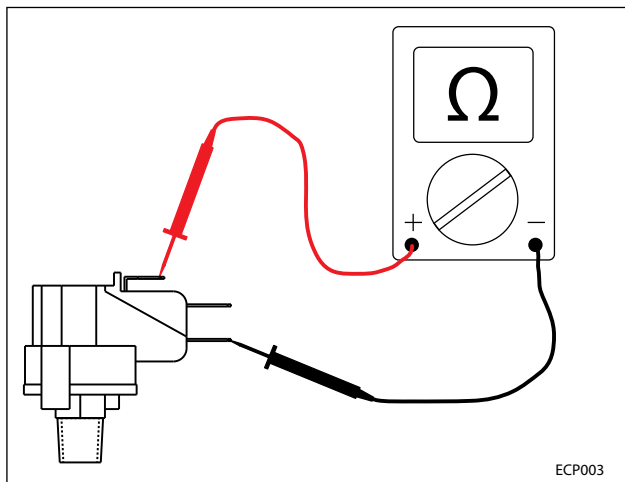

ECP003

3. Test the resistance of the switch using an ohmmeter between the common and normally open terminals. The switch should test as "O.L." or open. Replace the switch if the N.O. contacts are shorted.

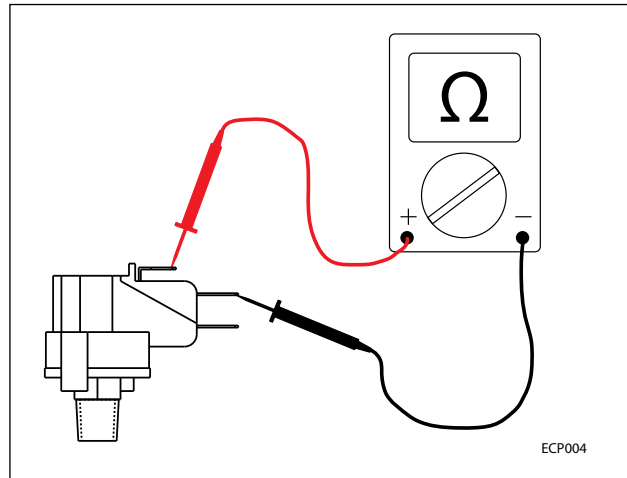

ECP004

4. Use a bicycle pump with pressure gauge to apply pressure to the switch as shown below. The normally open contacts should close at 25 +/- 2 psi (1.7 Bar), increasing pressure. Replace the switch if it does not open correctly.

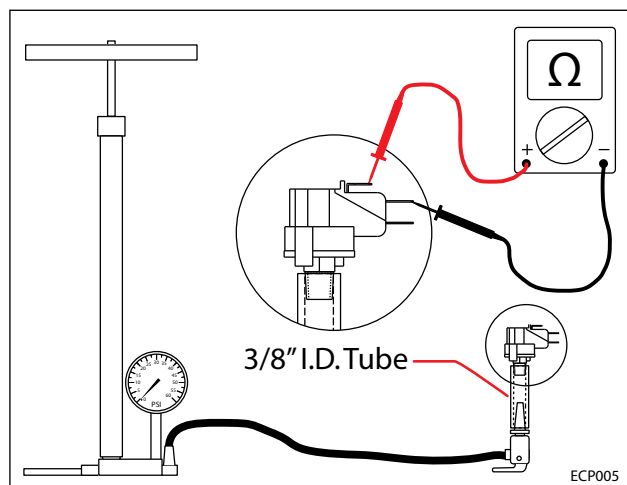

ECP005

TESTING FaST PUMP

FOR SAFETY: Before leaving or servicing machine, stop on level surface.

1. Key Off. Disconnect FaST pump outlet hose.

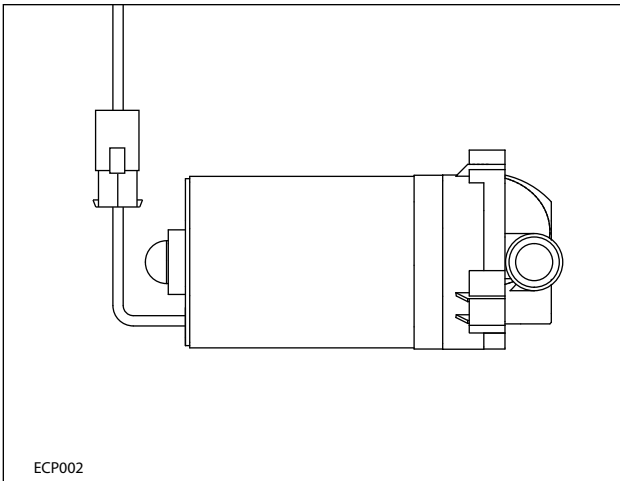

2. Fill the solution tank.
3. Connect a temporary outlet hose to the pump. The hose must be long enough to reach a 5 gallon bucket.

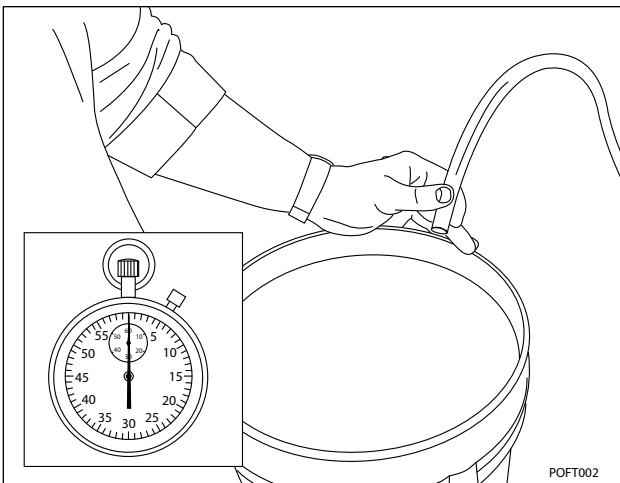

4. Enter Manual Mode and enable the FaST pump. See Manual Mode in the Troubleshooting section of this manual.
5. Use a stop watch to time how long it takes to fill a 5 gallon bucket. The open flow specification for the FaST pump is 1.25 GPM (4.7 LPM). The pump should fill the 5 gallon bucket in approximately 4.0 - 4.5 minutes. Replace the pump if it takes longer than 4.5 minutes to fill and the pump has an adequate water supply.

NOTE: Open flow is different than system flow and should not be used for scrubbing mode water consumption calculations.

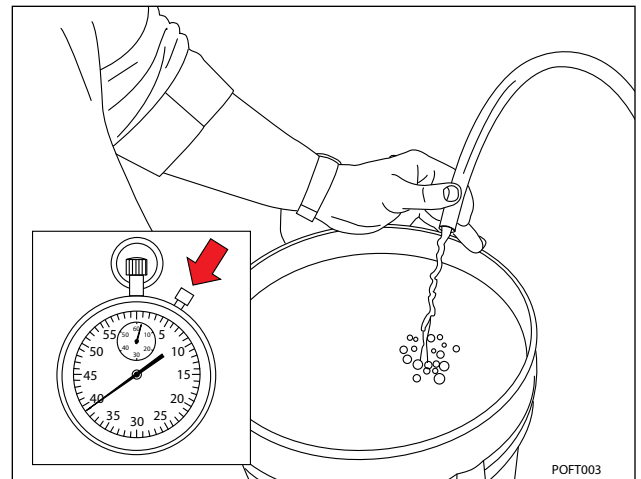
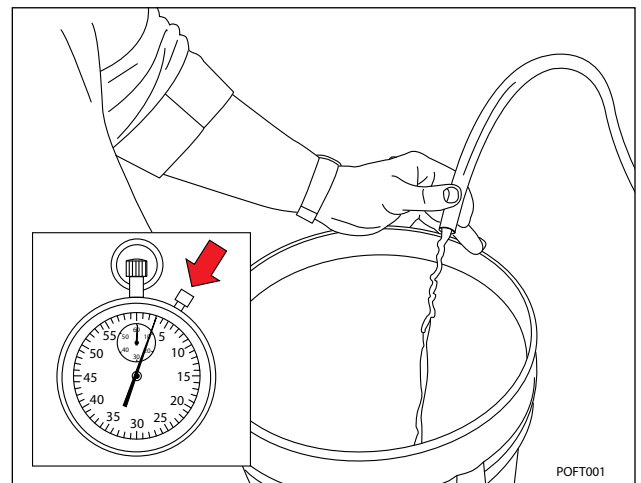

SERVICE

TESTING ES (EXTENDED SCRUB) PUMP

FOR SAFETY: Before leaving or servicing machine, stop on level surface.

1. Key Off. Disconnect ES pump outlet hose.

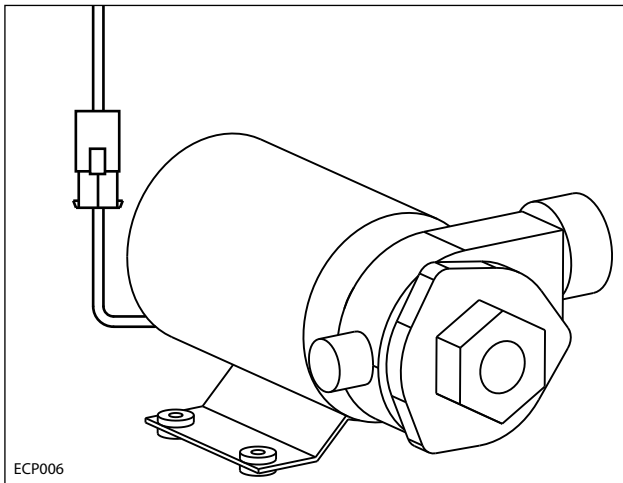

2. Fill the recovery tank.
3. Connect a temporary outlet hose to the pump. The hose must be long enough to reach a 5 gallon bucket.

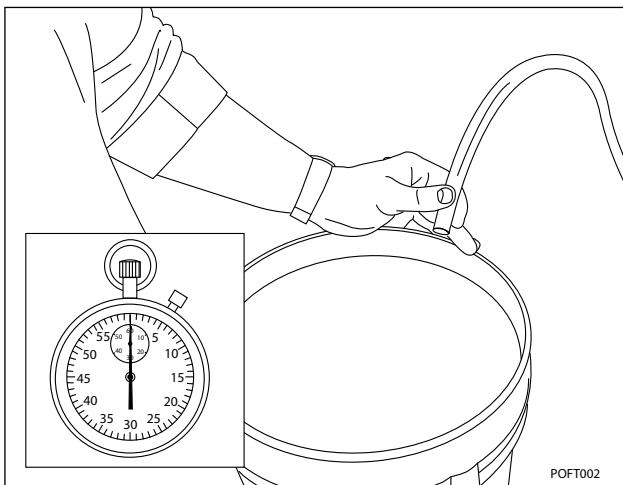

4. Enter Manual Mode and enable the ES pump. See Manual Mode in the Troubleshooting section of this manual.
5. Use a stop watch to time how long it takes to fill a 5 gallon bucket. The open flow specification for the ES pump is 20 GPM (76 LPM). The pump should fill the 5 gallon bucket in approximately 15-20 seconds. Replace the pump if it takes longer than 20 seconds to fill and the pump has an adequate water supply.

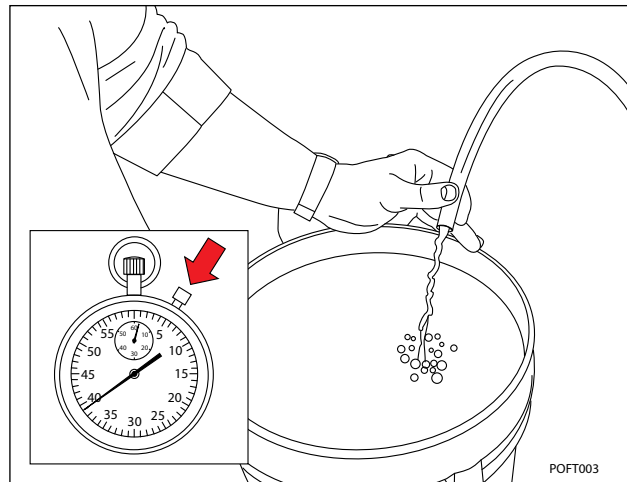
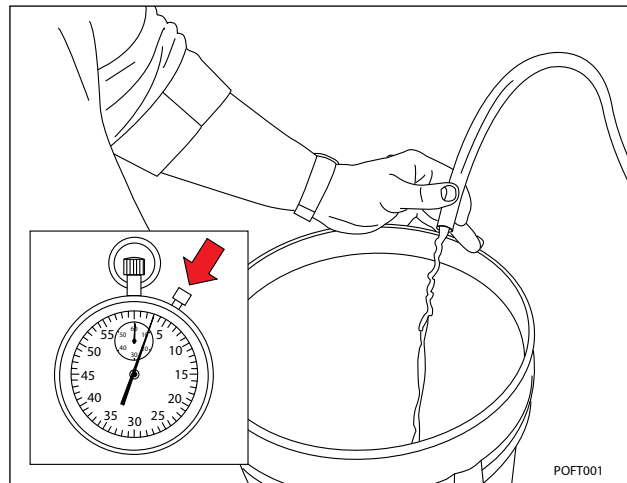



TENNANT COMPANY
 Technical Publications #15
 701 North Liliac Drive
 P.O. Box 1452
 Minneapolis, MN 55440-9947

POSTAGE WILL BE PAID BY ADDRESSEE

BUSINESS REPLY MAIL
 FIRST CLASS MAIL PERMIT NO. 94 MINNEAPOLIS, MN

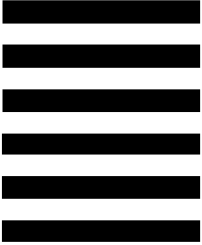

NO POSTAGE
 NECESSARY
 IF MAILED
 IN THE
 UNITED STATES



Fold along dotted lines
 Tape here



TENNANT COMPANY
 Technical Publications #15
 701 North Liliac Drive
 P.O. Box 1452
 Minneapolis, MN 55440-9947

POSTAGE WILL BE PAID BY ADDRESSEE

BUSINESS REPLY MAIL
 FIRST CLASS MAIL PERMIT NO. 94 MINNEAPOLIS, MN

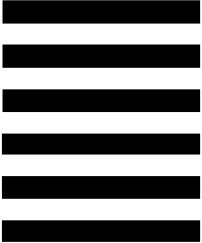

NO POSTAGE
 NECESSARY
 IF MAILED
 IN THE
 UNITED STATES



Fold along dotted lines
 Tape here