



SPEEDGLEAM® RIDER

QA Controls® Supervisor Settings

RIDER BURNISHER

SERVICE INFORMATION MANUAL

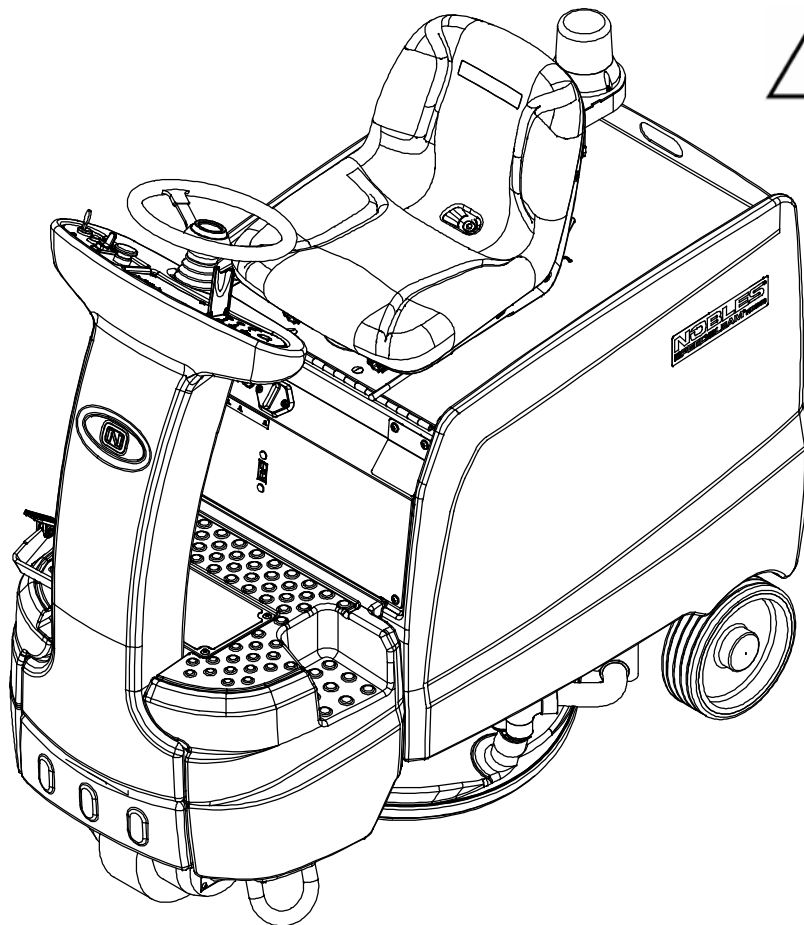

To view, print or download
the latest parts or operator's
manual, visit:
www.nobles.com/manuals

www.nobles.com/manuals

9010735
Rev. 01 (05-2013)



INTRODUCTION

This manual provides necessary service and maintenance instructions.



Read this manual completely and understand the machine before servicing it.

This machine will provide excellent service. However, the best results will be obtained at minimum costs if:

- The machine is operated with reasonable care.
- The machine is maintained regularly - per the maintenance instructions provided.
- The machine is maintained with manufacturer supplied or equivalent parts.

To view, print or download manuals online visit www.tennantco.com/manuals



PROTECT THE ENVIRONMENT

Please dispose of packaging materials and used machine components such as batteries in a safe environmentally way according to your local waste disposal regulations.



Always remember to recycle.

Tennant Company

PO Box 1452

Minneapolis, MN 55440

Phone: (800) 553-8033 or (763) 513-2850

www.tennantco.com

QA Contols and 1-STEP are US registered and unregistered trademarks of Tennant Company.

Trojan and HydroLINK are registered trademarks of Trojan Battery Company.

Specifications and parts are subject to change without notice.

Original Instructions. Copyright ©2012 Tennant Company.
All rights reserved. Printed in U.S.A.

INTENDED USE

The SpeedGleam Rider Burnisher machine is intended for commercial use, for example in hotels, schools, hospitals, factories, shops, offices and rental businesses. It is designed to burnish dry hard floor surfaces in an indoor environment and is not constructed for any other use. Use only recommended burnishing pads intended for machine application.

MACHINE DATA

Please fill out at time of installation for future reference.

Model No. - _____

Serial No. - _____

Installation Date - _____

Contents	Page
SAFETY PRECAUTIONS	1-1
GENERAL INFORMATION	2-1
COMPONENT LOCATOR	2-2
ELECTRICAL SCHEMATIC, MASTER	2-3
ELECTRICAL SCHEMATIC SYMBOLS	2-5
OPERATIONAL MATRIX	2-6
SPECIFICATIONS	2-7
FASTENER TORQUE	2-7
GENERAL MACHINE DIMENSIONS/ CAPACITIES	2-8
ELECTRICAL COMPONENTS	2-9
MACHINE DIMENSIONS	2-10
MAINTENANCE	
MAINTENANCE CHART	3-2
AFTER EVERY USE	3-3
AFTER WEEKLY USE	3-4
AFTER EVERY 50 HOURS OF USE	3-4
AFTER EVERY 200 HOURS OF USE	3-4
BATTERY MAINTENANCE	3-5
SEALED/AGM BATTERIES	3-5
WET/LEAD-ACID BATTERIES	3-5
HYDROLINK™ BATTERY WATERING SYSTEM (OPTION)	3-5
MACHINE JACKING	3-6
PUSHING TOWING AND TRANSPORTING THE MACHINE	3-7
STORING MACHINE	3-7
TROUBLESHOOTING	
CONFIGURATION MODES	4-2
HEAD SELECT MODE	4-2
BATTERY SELECT MODE	4-3
BURNISH PROPEL SPEED SELECT MODE	4-3
REVERSE ALARM SELECT MODE	4-4
DOWN PRESSURE SELECT MODE	4-4
SUPERVISOR MODE	4-5
ACTIVE DUST CONTROL SETUP MODE	4-6
DIAGNOSTIC MODES	4-7
DISPLAY SOFTWARE REVISION MODE	4-7
SELF-TEST MODE	4-7
MANUAL MODE	4-9
INPUT DISPLAY MODE	4-9
PROPEL DIAGNOSTICS MODE	4-11
FAULTS	4-13
BATTERY CHARGER	4-17
SUBSYSTEM TROUBLESHOOTING	4-18
BACK-UP ALARM	4-18
BATTERY CHARGER (ON BOARD)	4-20

Contents	Page
BATTERY CHARGER (OFF BOARD)	4-22
PARKING BRAKE, ELECTROMAGNETIC	4-24
BURNISH MOTOR	4-26
POWER-UP CIRCUIT	4-28
PROPEL	4-30
BURNISH HEAD LIFT	4-32
ADC (ACTIVE DUST CONTROL)	4-34
SERVICE	
MAIN BURNISH HEAD	5-2
LIFT ACTUATOR	5-2
REMOVAL	5-2
INSTALLATION	5-3
BURNISH HEAD ASSEMBLY	5-4
REMOVAL	5-4
INSTALLATION	5-5
BURNISH MOTOR	5-6
REMOVAL	5-6
INSTALLATION	5-6
CARBON BRUSHES	5-6
WHEEL DRIVE ASSEMBLY	5-8
STEERING ASSEMBLY	5-8
REMOVAL	5-8
INSTALLATION	5-10
WHEEL DRIVE ASSEMBLY	5-10
REMOVAL	5-10
INSTALLATION	5-11
CARBON BRUSHES	5-12
DRIVE TIRE	5-13
REMOVAL	5-13
INSTALLATION	5-14
PARKING BRAKE, ELECTROMAGNETIC ..	5-15
CHECKING AIR GAP	5-15
CHECKING ROTOR	5-16
TESTING BRAKE RESISTANCE	5-17
LOGIC BOARD	5-17
REMOVAL	5-17
INSTALLATION	5-18
THROTTLE/BRAKE SENSOR	5-19

SAFETY PRECAUTIONS

IMPORTANT SAFETY INSTRUCTIONS - SAVE THESE INSTRUCTIONS

The following warning precautions are used throughout this manual as indicated in their description:

⚠ WARNING: To warn of hazards or unsafe practices which could result in severe personal injury or death.

FOR SAFETY: To identify actions which must be followed for safe operation of equipment.

The following information signals potentially dangerous conditions to the operator. Know when these conditions can exist. Locate all safety devices on the machine. Report machine damage or faulty operation immediately.

⚠ WARNING: To Reduce the Risk of Fire, Explosion, Electric Shock or Injury:

- Read manual before operating machine.
- Do not use or pick up flammable materials.
- Do not use near flammable liquids, vapors or combustible dusts.
This machine is not equipped with an explosion proof motor. The electric motor will spark upon start up and during operation which could cause a flash fire or explosion if machine is used in an area where flammable vapors/liquids or combustible dusts are present.
- Batteries emit hydrogen gas. Explosion or fire can result. Keep sparks and open flame away when charging. Open battery compartment for ventilation.
- Disconnect battery cables and charger cord before cleaning and servicing machine.
- Do not charge batteries with damaged cord. Do not modify plug.

If the charger supply cord is damaged or broken, it must be replaced by the manufacturer or its service agent or a similarly qualified person in order to avoid a hazard.

The use of unapproved battery chargers may damage the battery and potentially cause a fire hazard.

- Do not use outdoors or on wet surfaces. Store indoors. This machine is for dry use only.
- This machine is not suitable for picking up hazardous dust.

FOR SAFETY:

1. Do not operate machine:
 - Unless trained and authorized.
 - Unless operator manual is read and understood.
 - Unless mentally and physically capable of following machine instructions.
 - Under the influence of alcohol or drugs.
 - While using a cell phone or other types of electronic devices.
 - If not in proper operating condition.
 - In outdoor areas. This machine is for indoor use only.
 - With pads or accessories not supplied or approved by Tennant. The use of other pads may impair safety.
 - In areas with possible falling objects.
 - In areas that are too dark to safely see the controls or operate machine.
 - With brake disabled.
 - Without dust bag and/or filters in place.
2. Before operating machine:
 - Make sure all safety devices are in place and operate properly.
 - Check brakes and steering for proper operation.
 - Inspect charger cord regularly for signs of damage or aging.
3. When operating machine:
 - Use only as described in this manual.
 - Report machine damage or faulty operation immediately.
 - Reduce speed when turning.
 - Drive slowly on inclines and slippery surfaces.
 - Do not operate on inclines that exceed a 7% grade level.
 - Keep all parts of body inside operator station while machine is moving.
 - Do not carry passengers on machine.
 - Keep hands away from spinning pad.
 - Use care when reversing machine.
 - Never allow children to play on or around machine.
 - Keep children and unauthorized persons away from machine.
 - Do not allow to be used as a toy.

SAFETY PRECAUTIONS

SAFETY PRECAUTIONS

4. Before leaving machine:
 - Stop on level surface.
 - Turn off machine and remove key.
5. When servicing machine:
 - Disconnect battery cables and charger plug before working on machine.
 - All work must be done with sufficient visibility and lighting.
 - All repairs must be performed by a trained service mechanic.
 - Use manufacturer supplied or approved replacement parts.
 - Do not modify the machine from its original design.
 - Avoid moving parts. Do not wear loose clothing or jewelry. Secure long hair when working around machinery.
 - Do not disconnect the off-board charger's DC cord from the machine's receptacle when the charger is operating. Arcing may result. If the charger must be interrupted during charging, disconnect the AC power supply cord first.
 - Keep work area well ventilated.
 - Avoid contact with battery acid.
 - Do not power spray or hose off machine.
 - Do not push or tow the machine on inclines with the brake disabled.
 - Jack machine up at designated locations only. Block machine up with jack stands.
 - Block machine tires before jacking machine up.
 - Use jack or hoist that will support machine weight.
 - Wear appropriate personal protection equipment as needed and where recommended in this manual.
6. When loading/unloading machine onto/off truck or trailer:
 - Use a ramp that can support the machine weight and operator.
 - Do not operate the machine on a ramp incline that exceeds a 19.5% grade level.
 - Use a winch if ramp incline exceeds a 19.5% grade level.
 - Do not push or tow the machine on inclines with the brake disabled.
 - Lower the pad driver after loading.
 - Turn machine off.
 - Block machine wheels.
 - Use tie-down straps to secure machine.



For Safety: wear protective gloves.



For Safety: wear eye protection.



For Safety: wear protective dust mask.

SAFETY PRECAUTIONS

SAFETY LABELS

The safety labels appear on the machine in the locations indicated. Replace labels if they are missing or become damaged or illegible.

WARNING LABEL - Located on steering column.



FOR SAFETY LABEL - Read manual before operating machine.
- Located on seat panel



WARNING LABEL - Disconnect battery cables before servicing machine.

- Located behind kick panel on control board cover.



WARNING LABEL - Batteries emit hydrogen gas. Explosion or fire can result. Keep sparks and open flame away when charging.

- Located on backside of seat panel.



SAFETY PRECAUTIONS

SAFETY PRECAUTIONS

SECTION 2

Contents	Page
GENERAL INFORMATION	2-1
COMPONENT LOCATOR.....	2-2
ELECTRICAL SCHEMATIC, MASTER	2-3
ELECTRICAL SCHEMATIC SYMBOLS	2-5
OPERATIONAL MATRIX.....	2-6
SPECIFICATIONS.....	2-7
FASTENER TORQUE	2-7
GENERAL MACHINE DIMENSIONS/ CAPACITIES.....	2-8
ELECTRICAL COMPONENTS.....	2-9
MACHINE DIMENSIONS.....	2-10

GENERAL INFORMATION

COMPONENT LOCATOR

Components	
A	Active Dust Control Vacuum*
B	Seat Switch
C	Burnish Motor
D	Contact Switch, Pad Change Mode
E	Circuit Breaker-3 (150A Resettable) Hour Meter, Circuit Breaker-1 (5A), Circuit Breaker-3 (5A)
F	Wheel Drive Assembly, Electromagnetic Parking Brake
G	M1 and M2 Contactors, Current Shunt (Burnish Motor) D1 and D2 Diodes
H	Throttle/Brake Sensor
I	Circuit Board
J	Flashing Light*
K	Module, IRIS™ Telemetry*
L	On-Board Battery Charger*
M	Current Shunt (IRIS™)*
N	Actuator, Burnish Head Lift
O	Throttle/Brake Sensor
P	Key Switch, E-Stop Switch, Directional Switch, BDI (Battery Discharge Indicator)
Q	Touch Panel
R	Battery Compartment

* Optional Equipment



ELECTRICAL SCHEMATIC (1 of 2)

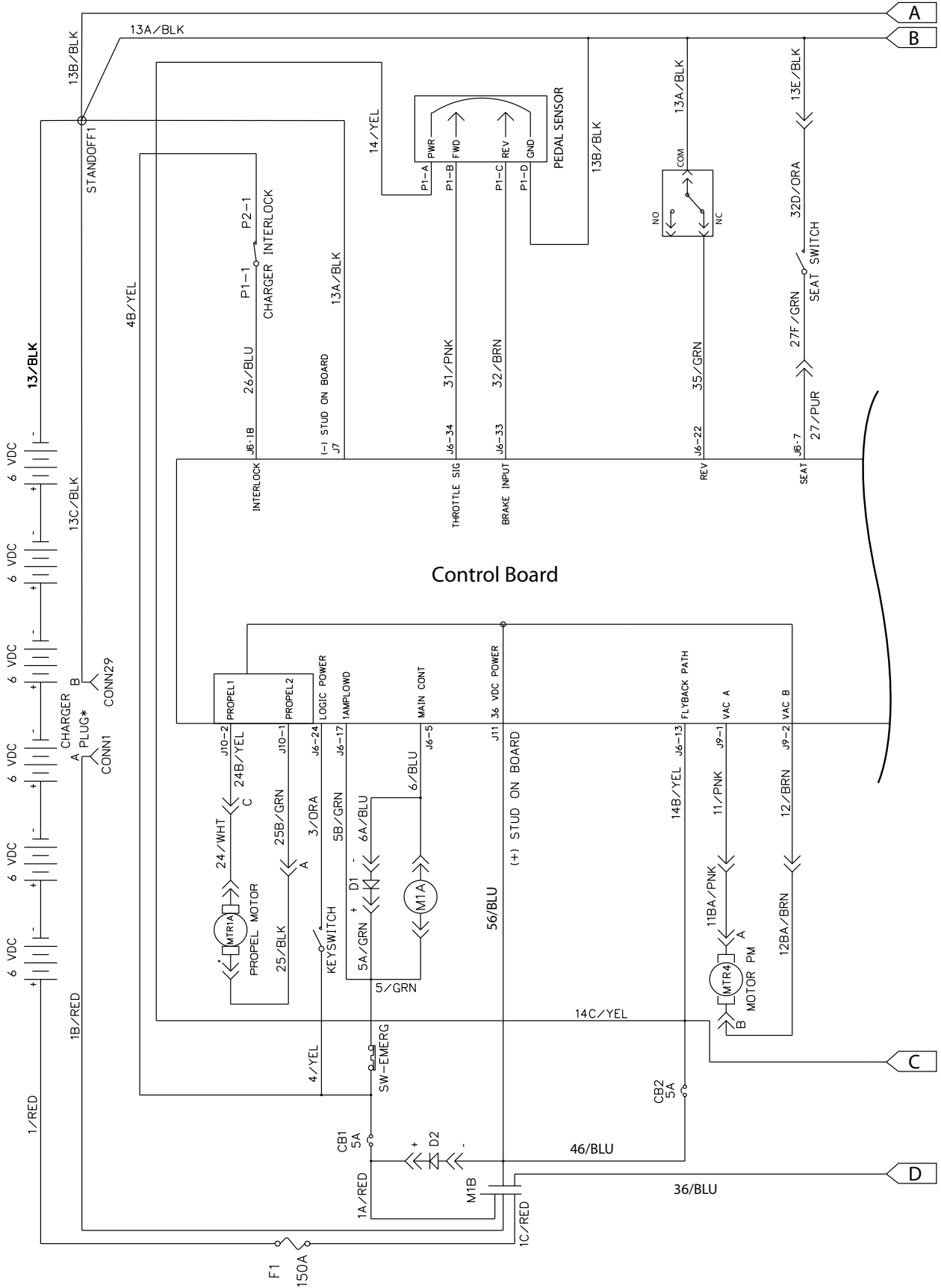

GENERAL INFORMATION

ELECTRICAL SCHEMATIC (2 of 2)

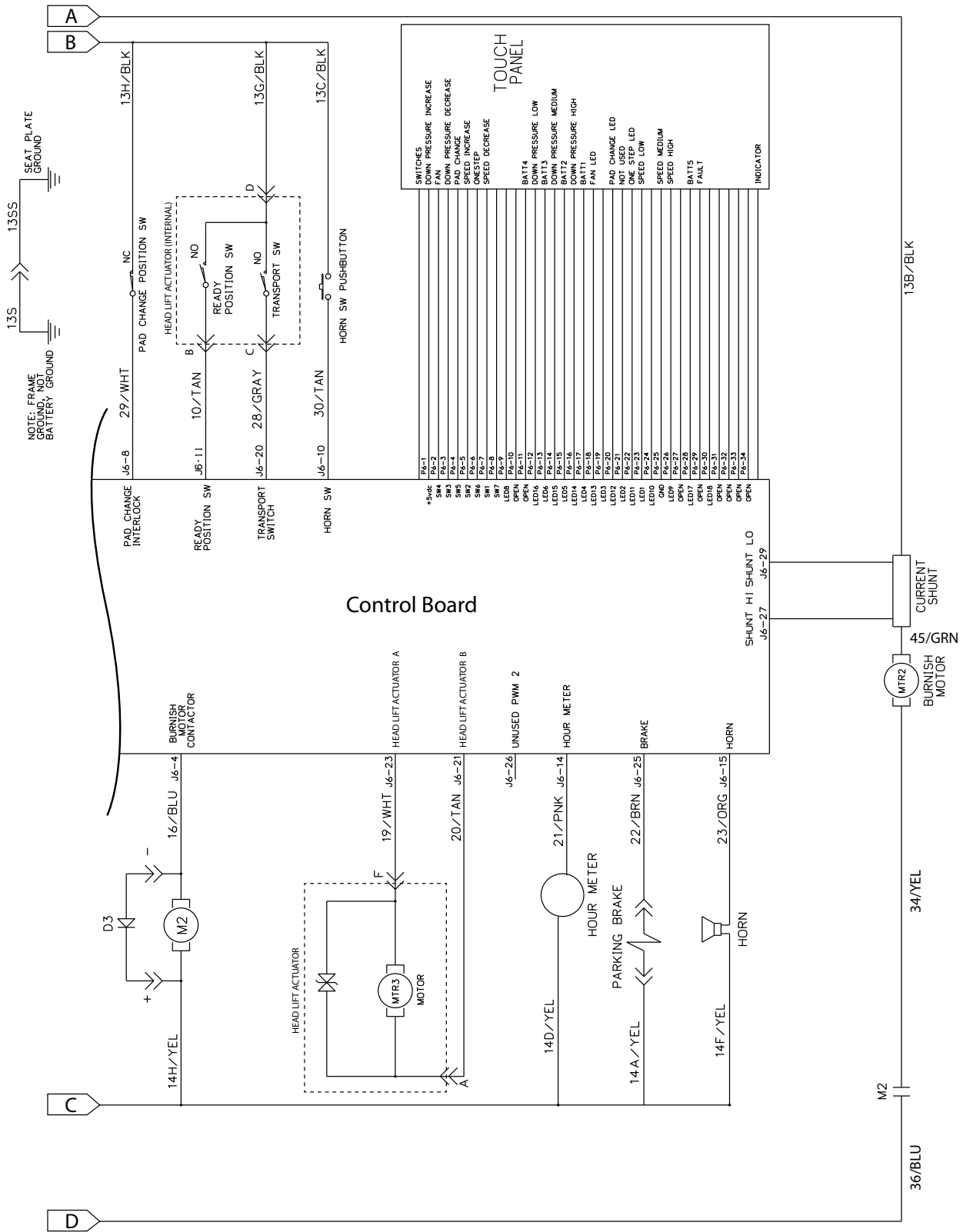

ELECTRICAL SCHEMATIC SYMBOLS

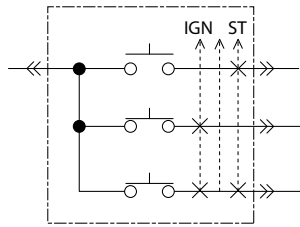

Key Switch

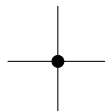

Connected

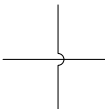

Not Connected

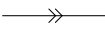

Connector



Energized

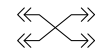

Adaptor Harness

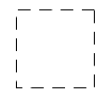

Notes

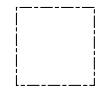

Assembly



AC Plug

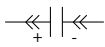

Capacitor



Battery



Circuit Breaker



Fuse



Diode



Single Continuation Tab



Double Continuation Tab



Relay Coil

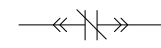

N.C. Relay Contacts

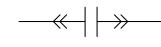

N.O. Relay Contacts



Horn or Alarm



Light

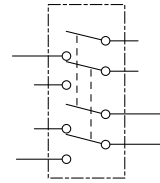

DPDT Switch

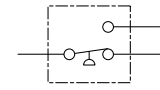

Pressure Switch



Motor

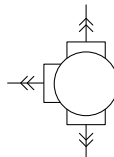

3 Phase AC Induction Motor

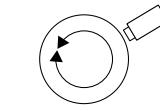

Motor Encoder



Sensor (Variable Resistor)

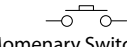

Momentary Switch N.O.

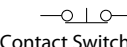

Contact Switch N.C.



Solenoid Valve

GENERAL INFORMATION

SpeedGleam Rider OPERATIONAL MATRIX

FUNCTION	ENABLED	DISABLED
Burnish Motor - On	<ul style="list-style-type: none"> • 1-STEP Burnish ON • Fwd/Rev Throttle Command 	<ul style="list-style-type: none"> • 1-STEP Burnish OFF • Neutral - Ready State • Low Battery Voltage • Load Current Fault
Active Dust Control	<ul style="list-style-type: none"> • 1-STEP Burnish ON • Vacuum ON 	<ul style="list-style-type: none"> • 1-STEP Burnish OFF • Vacuum OFF • Low Battery Voltage • Load Current Fault
Pad Change Mode	<ul style="list-style-type: none"> • Pad Change Button ON 	<ul style="list-style-type: none"> • 1-STEP Burnish ON • Pad Change Button OFF • Low Battery Voltage • Load Current Fault
Burnish Head Down (completely - pad ON)	<ul style="list-style-type: none"> • 1-STEP Burnish ON • Fwd/Rev Throttle Command 	<ul style="list-style-type: none"> • 1-STEP Burnish OFF • Neutral - Ready State • Low Battery Voltage • Load Current Fault
Burnish Head - Ready State (slightly off floor - pad OFF)	<ul style="list-style-type: none"> • 1-STEP Burnish ON • Neutral Throttle Command 	<ul style="list-style-type: none"> • 1-STEP Burnish OFF • Fwd/Rev Throttle Command • Low Battery Voltage • Load Current Fault
Propel	<ul style="list-style-type: none"> • Seat Switch Closed • Fwd/Rev Throttle Command • Fwd/Rev Switch Input 	<ul style="list-style-type: none"> • Seat Switch Open • Battery Charger ON • Neutral - Ready State • Pad Change Mode • Brake Command • Load Current Fault
Electromagnetic Parking Brake	<ul style="list-style-type: none"> • Key OFF • Emergency Stop Switch Open (Down) • Battery Charger ON • Neutral (1-2 Second Delay) • Seat Switch Open • Load Current Fault 	<ul style="list-style-type: none"> • Key ON • Emergency Stop Switch Closed (Up) • Fwd/Rev Throttle Command • Seat Switch Closed
Back-Up Alarm	<ul style="list-style-type: none"> • Reverse Switch Input 	<ul style="list-style-type: none"> • Forward Switch Input • Hospital Mode - Silent • Load Current Fault

MOM001

GENERAL INFORMATION

FASTENER TORQUE

SAE (STANDARD)

Thread Size	SAE Grade 1	SAE Grade 2 Carriage Bolts	Thread Cutting Thread Rolling	SAE Grade 5 Socket & Stainless Steel	SAE Grade 8	Headless Socket Set Screws	Square Head Set Screws	
4 (.112)	(5) - (6.5)					(4) - (6)		Inch Pounds
5 (.125)	(6) - (8)					(9) - (11)		
6 (.138)	(7) - (9)		(20) - (24)			(9) - (11)		
8 (.164)	(12) - (16)		(40) - (47)			(17) - (23)		
10 (.190)	(20) - (26)		(50) - (60)			(31) - (41)		
1/4 (.250)	4 - 5	5 - 6	7 - 10	7 - 10	10 - 13	6 - 8	17 - 19	Foot Pounds
5/16 (.312)	7 - 9	9 - 12	15 - 20	15 - 20	20 - 26	13 - 15	32 - 38	
3/8 (.375)	13 - 17	16 - 21		27 - 35	36 - 47	22 - 26	65 - 75	
7/16 (.438)	20 - 26	26 - 34		43 - 56	53 - 76	33 - 39	106 - 124	
1/2 (.500)	27 - 35	39 - 51		65 - 85	89 - 116	48 - 56	162 - 188	
5/8 (.625)		80 - 104		130 - 170	171 - 265		228 - 383	
3/4 (.750)		129 - 168		215 - 280	313 - 407		592 - 688	
1 (1.000)		258 - 335		500 - 650	757 - 984		1281 - 1489	

METRIC

Thread Size	4.8/5.6	8.8 Stainless Steel	10.9	12.9	Set Screws
M3	43 - 56 Ncm	99 - 128 Ncm	139 - 180 Ncm	166 - 215 Ncm	61 - 79 Ncm
M4	99 - 128 Ncm	223 - 290 Ncm	316 - 410 Ncm	381 - 495 Ncm	219 - 285 Ncm
M5	193 - 250 Ncm	443 - 575 Ncm	624 - 810 Ncm	747 - 970 Ncm	427 - 554 Ncm
M6	3.3 - 4.3 Nm	7.6 - 9.9 Nm	10.8 - 14 Nm	12.7 - 16.5 Nm	7.5 - 9.8 Nm
M8	8.1 - 10.5 Nm	18.5 - 24 Nm	26.2 - 34 Nm	31 - 40 Nm	18.3 - 23.7 Nm
M10	16 - 21 Nm	37 - 48 Nm	52 - 67 Nm	63 - 81 Nm	
M12	28 - 36 Nm	64 - 83 Nm	90 - 117 Nm	108 - 140 Nm	
M14	45 - 58 Nm	102 - 132 Nm	142 - 185 Nm	169 - 220 Nm	
M16	68 - 88 Nm	154 - 200 Nm	219 - 285 Nm	262 - 340 Nm	
M20	132 - 171 Nm	300 - 390 Nm	424 - 550 Nm	508 - 660 Nm	
M22	177 - 230 Nm	409 - 530 Nm	574 - 745 Nm	686 - 890 Nm	
M24	227 - 295 Nm	520 - 675 Nm	732 - 950 Nm	879 - 1140 Nm	

GENERAL INFORMATION

GENERAL MACHINE DIMENSIONS/CAPACITIES

MODEL	24 in / 610 mm	27 in / 686 mm
Length	58.5 in / 1486 mm	58.5 in / 1486 mm
Width	30 in / 762 mm	31.5 in / 800 mm
Height	55 in / 1397 mm	55 in / 1397 mm
Weight	596 lb / 270 kg	600 lb / 272 kg
Weight with batteries	1,346 lb / 610 kg	1,350 lb / 612 kg
GVWR	1648 lb / 747 kg	1650 lb / 748 kg
Burnish path width	24 in / 610 mm	27 in / 686 mm
Productivity rate (max.)	30,250 ft ² /hr / 2,813 m ² /hr	34,375 ft ² /hr / 3,197 m ² /hr
Burnishing speeds (standard settings)	Low: 150 fpm / 45.7 mpm Med: 175 fpm / 53.3 mpm High: 200 fpm / 61.0 mpm	Low: 150 fpm / 45.7 mpm Med: 175 fpm / 53.3 mpm High: 200 fpm / 61.0 mpm
Transport speed (max.)	Fwd: 435 fpm/ 8 Kpmh Rev: 240 fpm/ 4.4 Kpmh	Fwd: 435 fpm/ 8 Kpmh Rev: 240 fpm/ 4.4 Kpmh
Aisle turn (min.)	70 in / 1,778 mm	70 in / 1,778 mm
Grade level (max.)	Transport: 19.5%, Burnishing: 7%	Transport: 19.5%, Burnishing: 7%
Propel Motor	24 V, 41 A, 1.1 hp / 0.82kW	24 V, 41 A, 1.1 hp / 0.82kW
Pad motor	36 V, 100 A, 9.4 hp max / 7 kW	36 V, 100 A, 9.4 hp max / 7 kW
Pad Pressure	Low: 45 lb/ 20.4 Kg Med: 65 lb/ 29.5 Kg High: 85 lb/ 38.5 Kg	Low: 45 lb/ 20.4 Kg Med: 65 lb/ 29.5 Kg High: 85 lb/ 38.5 Kg
Pad speed	1500-1600 rpm	1500-1600 rpm
Vacuum motor (Active Dust Control)	36 V, 12 A, 1400W / 1.4 kW	36 V, 12 A, 1400W / 1.4 kW
HEPA filtration	99.97% @ 0.3 micron	99.97% @ 0.3 micron
Dust bag capacity	6 qt / 5.7 l	6 qt / 5.7 l
Machine Voltage	36 VDC	36 VDC
Battery capacity	Six 6V, 435 Ah Wet/lead-acid (std.) Six 6V, 390 Ah AGM (opt.)	Six 6V, 435 Ah Wet/lead-acid (std.) Six 6V, 390 Ah AGM (opt.)
Total power consumption	120A / 4.3 kw nominal	120A / 4.3 kw nominal
Run time (max.)	3.0 hours	3.0 hours
Battery charger	120 VAC, 60 Hz, Output 36 VDC, 25 A	120 VAC, 60 Hz, Output 36 VDC, 25 A
	220/240 VAC, 50/60 Hz Output 36 VDC, 25 A	220/240 VAC, 50/60 Hz Output 36 VDC, 25 A
Protection grade	IPX3	IPX3
Sound pressure level L_{pA}	69 dB(A)	69 dB(A)
Sound uncertainty K_{pA}	3.0 dB(A)	3.0 dB(A)
Sound power level L_{wA} + uncertainty K_{wA}	xx dB(A)	xx dB(A)
Machine vibration at hand-arm	<2.5 m/s ²	<2.5 m/s ²
Machine vibration at operator seat	<2.5 m/s ²	<2.5 m/s ²
Machine vibration uncertainty K	0.2 m/s ²	0.2 m/s ²
Ambient operating temperature	Min: 32°F/0°C Max: 110°F/43°C	Min: 32°F/0°C Max: 110°F/43°C

Values per IEC 60335-2-72

Specifications are subject to change without notice.

SPECIFICATIONS

ELECTRICAL COMPONENTS *(For Reference Only)*

Component	Measure		
Contactator Coil, M1	77 Ω +/- 10%		
Contactator Coil, M2	77 Ω +/- 10%		
Actuator, Scrub head lift	1 - 3 Amps Continuous		
Motor, Vacuum Fan	2.5 +/- 5% Amps (3.0 +/- 5% Amps Economy Mode)		
Motor, Propelling (transport speed)	14-18 Amps Continuous, 41Amps Max		
Brake, Parking	29 Ω +/- 5%		
Motor, Main - 24 in Pad	Low Range	Medium - Default Range	High Range
Down Pressure 1 LED	65 Amps	70 Amps	75 Amps
Down Pressure 2 LEDs	73 Amps	78 Amps	83 Amps
Down Pressure 3 LEDs	80 Amps	85 Amps	90 Amps
Motor, Main - 27 in Pad	Low Range	Medium - Default Range	High Range
Down Pressure 1 LED	65 Amps	70 Amps	75 Amps
Down Pressure 2 LEDs	73 Amps	78 Amps	83 Amps
Down Pressure 3 LEDs	80 Amps	85 Amps	90 Amps

Specifications are subject to change without notice.

GENERAL INFORMATION

SPECIFICATIONS

MACHINE DIMENSIONS

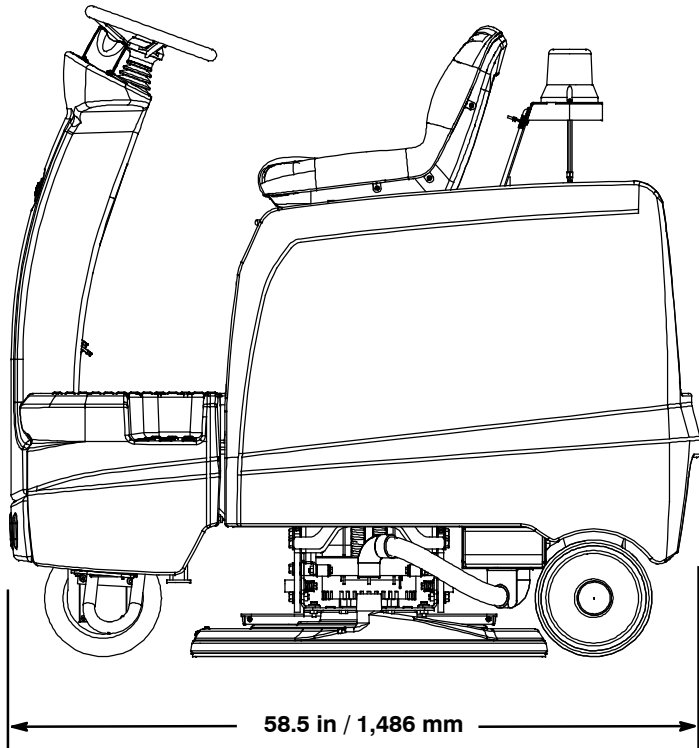
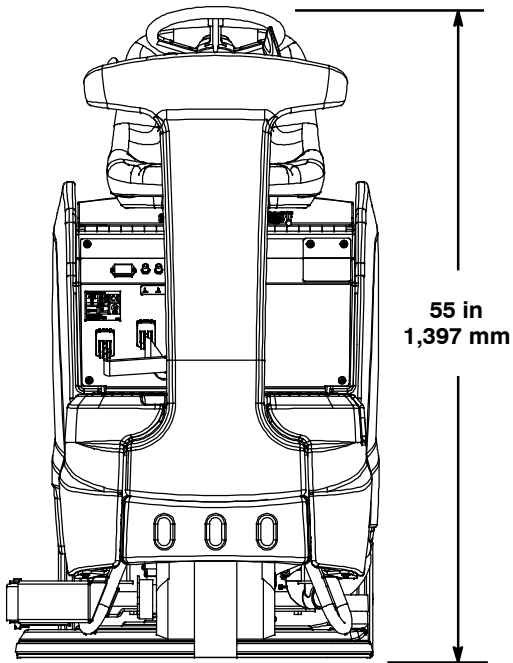
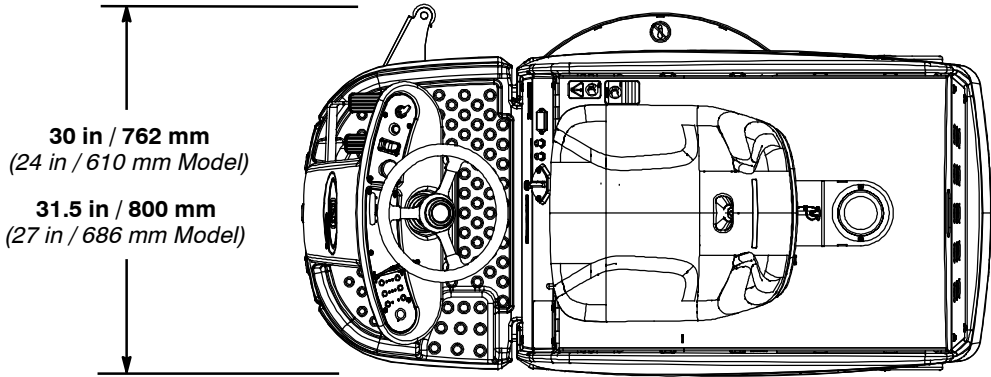

SECTION 3

Contents	Page
MAINTENANCE	
MAINTENANCE CHART.....	3-2
AFTER EVERY USE.....	3-3
AFTER WEEKLY USE.....	3-4
AFTER EVERY 50 HOURS OF USE.....	3-4
AFTER EVERY 200 HOURS OF USE.....	3-4
BATTERY MAINTENANCE.....	3-5
SEALED/AGM BATTERIES.....	3-5
WET/LEAD-ACID BATTERIES.....	3-5
HYDROLINK™ BATTERY WATERING SYSTEM (OPTION).....	3-5
MACHINE JACKING.....	3-6
PUSHING TOWING AND TRANSPORTING THE MACHINE.....	3-7
STORING MACHINE.....	3-7

MAINTENANCE

MAINTENANCE CHART

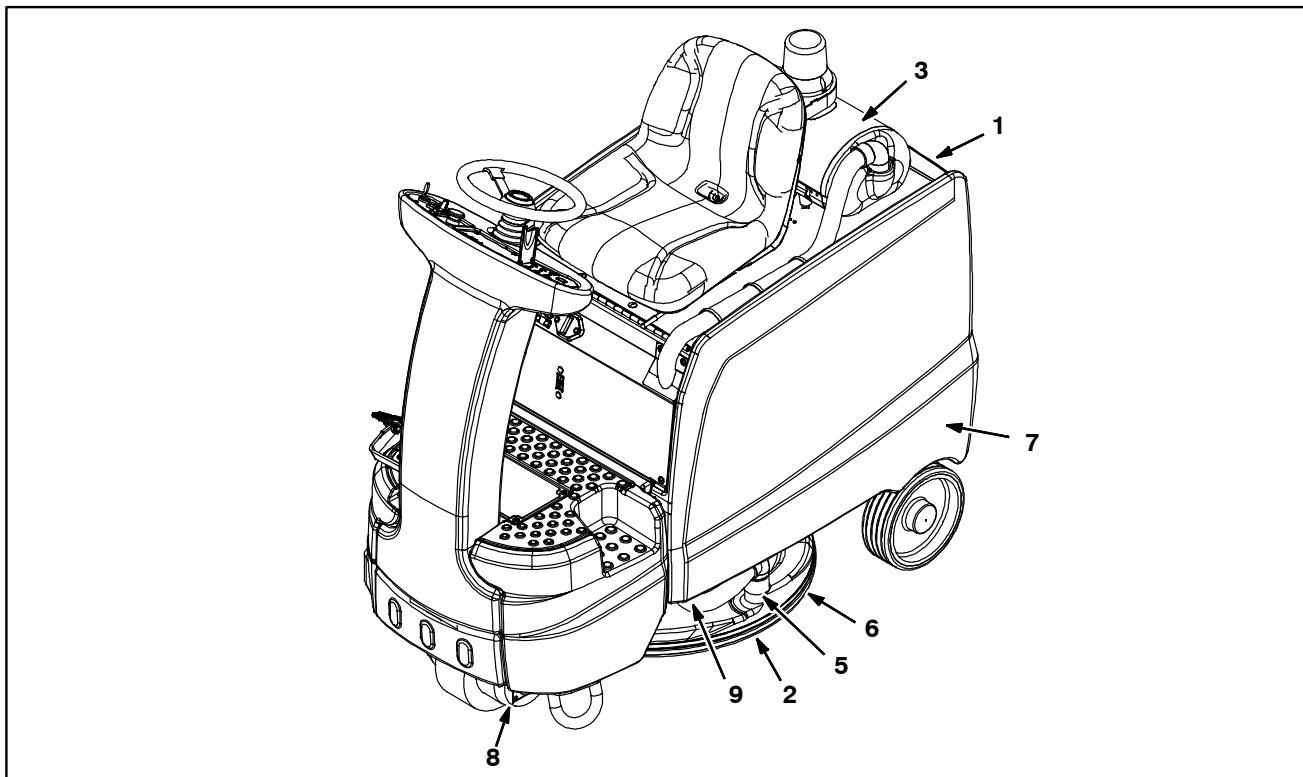

Interval/ Hours	Person Resp.	Key	Description	Procedure
Daily	O	1	Batteries	Charge
	O	2	Burnishing pad	Check, rotate or replace
	O	3	Dust collection bag	Check, replace
	O	5	Vacuum Hose	Check, clean
Weekly	O	1	Battery electrolyte level	Check
50 Hours	O	6	Burnishing head dust skirt	Check for wear and damage
	O	6	Burnishing Head	Clean with air pressure hose
	O	7	Machine	Clean with damp cloth
200 Hours	O	1	Batteries, terminals and cables	Check, clean
	O	3	Vacuum HEPA filter	Check, clean, replace
	O	3	Vacuum exhaust filter	Check, clean, replace
	T	7	Steering chain and pivot points	Lubricate with grease
750 Hours	T	8	Propel Motor	Replace carbon brushes
1000 Hours	T	9	Pad Motor	Replace carbon brushes

O = Operator T = Trained Personnel

MACHINE MAINTENANCE

To keep the machine in good working condition, simply perform the following maintenance procedures.

FOR SAFETY: Before leaving or servicing machine, stop on a level surface and turn off machine.

⚠ WARNING: When servicing machine, wear appropriate personal protection equipment as needed. All repairs must be performed by a trained service mechanic.

AFTER EVERY USE

1. Rotate the burnishing pad or change to a new pad (Figure 38).



FIG. 38

2. Check the dust collection bag for fullness. Replace bag when full (Figure 39). See *INSTALLING DUST COLLECTION BAG*.



FIG. 39

3. Remove the cloth filter bag from the active dust control unit and clean (Figure 40). Turn the bag inside out and tap off any dust buildup. Do not wash bag. Replace bag if worn or damaged.

NOTE: For optimum filtration and dust containment always use paper bag with cloth bag.



FIG. 40

4. Check vacuum hose for clogging. Clean hose as necessary (Figure 41).



FIG. 41

5. Charge batteries (Figure 42). See *CHARGING BATTERIES*.



ON-BOARD CHARGER

OFF-BOARD CHARGER

FIG. 42

MAINTENANCE

AFTER WEEKLY USE

Check the electrolyte level in all batteries (Figure 43). See BATTERY MAINTENANCE.



FIG. 43

AFTER EVERY 50 HOURS OF USE

1. Check the dust skirt for wear or damage (Figure 44). Replace if necessary.



FIG. 44

2. Clean the burnishing head, pad motor and propel motor of any dust buildup using an air pressure hose (Figure 45). Maximum air pressure 100 psi / 690 kPa.

⚠ WARNING: When servicing machine, wear appropriate personal protection equipment as needed.



FIG. 45

3. Clean the outside surface of the machine with an all purpose cleaner and damp cloth (Figure 46).



FIG. 46

AFTER EVERY 200 HOURS OF USE

1. Clean batteries and check for loose battery cable connections.
2. Replace the HEPA filter in the active dust control vacuum (Figure 47). The HEPA filter is located below the cloth filter bag.



FIG. 47

3. Replace the exhaust filter in the active dust control vacuum (Figure 48). Remove the filter holder at bottom of vacuum to access exhaust filter.



FIG. 48

BATTERY MAINTENANCE

The lifetime of the batteries is limited to the number of charges the batteries receive. To get the most life from the batteries, only recharge the batteries when the battery discharge indicator begins to blink. It's also important to maintain the proper electrolyte levels during the life of the battery.

Your machine is equipped with either wet/lead-acid or sealed AGM batteries supplied by Tennant.

FOR SAFETY: When servicing batteries, wear protective gloves and eye protection. Avoid contact with battery acid.

SEALED AGM BATTERIES

The sealed AGM batteries are maintenance free and do not require any attention other than routine charging as described in this manual.

WET/LEAD-ACID BATTERIES

The wet/lead-acid batteries require routine maintenance as described below.

NOTE: If your machine is equipped with the HydroLINK battery watering system option, see HYDROLINK BATTERY WATER SYTEM.

Check the battery electrolyte level weekly. The electrolyte level should be slightly above the battery plates as shown (Figure 49). Add distilled water if low. **DO NOT OVERFILL.** The electrolyte will expand and may overflow when charging.



Before Charging

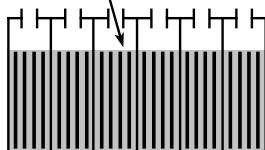

The level should be slightly above the battery plates

After Charging

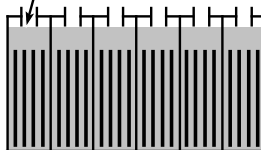

The level should be slightly below the sight tubes

FIG. 49

After every 200 hours of use, check for loose battery connections and clean the surface of the batteries, including terminals and cable clamps to prevent battery corrosion. Use a scrub brush with a strong mixture of baking soda and water (Figure 50). Do not remove battery caps when cleaning batteries.



FIG. 50

HYDROLINK™ BATTERY WATERING SYSTEM (OPTION)

The following instructions are for models equipped with the HydroLINK battery watering system option.

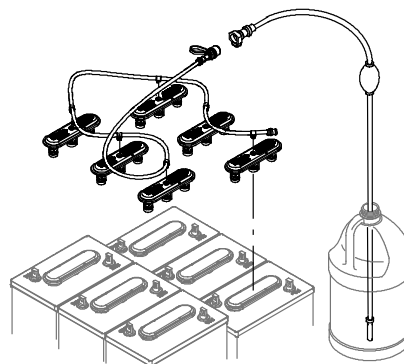

The optional HydroLINK battery watering system provides a safe and easy way to maintain the proper electrolyte levels in your batteries.

This battery watering system is also offered as an aftermarket kit (p/n 9010301). It is designed exclusively for Trojan® wet/lead-acid batteries.

Before using the battery watering system check hoses and connections for damage or wear.

1. Fully charge batteries prior to using the battery watering system. Do not add water to batteries before charging, the electrolyte level will expand and may overflow when charging.

MAINTENANCE

- After charging batteries, check the battery electrolyte level indicators located on the battery covers (Figure 51). If the level indicator is white add water as described in the following instructions. If the level indicators are black the electrolyte is at the correct level, no water is required.



FIG. 51

- Locate the battery fill hose coupler inside the battery compartment. Remove the dust cap and connect the hand pump hose (Figure 52).



FIG. 52

- Submerge the other end of the hand pump hose into a bottle of distilled water (Figure 53).



FIG. 53

- Squeeze the bulb on the hand pump hose until firm (Figure 54). The level indicators will turn black when full.

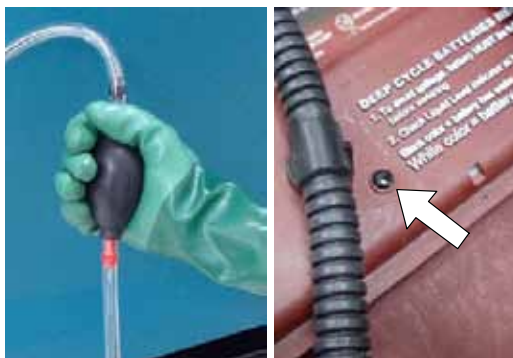

FIG. 54

- After adding water, replace the dust cap on the battery fill hose and store the hand pump hose inside the machine's battery compartment for future use.

MACHINE JACKING

Use the designated jacking locations for jacking up the machine (Figure 55). Use a jack capable of supporting the weight of the machine. Position the machine on a flat, level surface and block the tires before jacking.

FOR SAFETY: When servicing machine, jack machine up at designated locations only. Use jack or hoist that will support machine weight. Block machine up with jack stands.

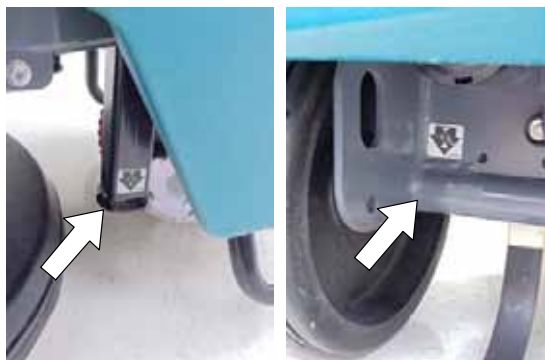

FIG. 55

PUSHING, TOWING, AND TRANSPORTING MACHINE

PUSHING OR TOWING THE MACHINE

The machine can be pushed or towed if the machine becomes disabled. Before attempting to push or tow the machine, the electromagnetic brake system must be disabled. To disengage the brake, insert a small standard screwdriver between the electronic brake lever and the hub (Figure 56).

FOR SAFETY: When brake is disabled, do not push or tow the machine on inclines or operate machine.



FIG. 56

Only push or tow the machine on a level surface. Do not exceed 2 mph / 3.2 kph. When towing machine, only tow it from the front by the stabilizer arms (U-shape bars).

Immediately after pushing or towing the machine, enable the brake. Never leave or operate the machine with the brake disabled.

TRANSPORTING THE MACHINE

When transporting the machine by use of trailer or truck, carefully follow the loading and tie-down procedures:

FOR SAFETY: When transporting machine, go slowly on inclines and slippery surfaces.

1. Raise the burnishing head to the up position.
2. Load the machine using a ramp that can support the machine weight and operator. Do not operate the machine on a ramp incline that exceeds a 19.5% grade level (Figure 57). A winch must be used when ramp incline exceeds a 19.5% grade level.

FOR SAFETY: When transporting machine, use a ramp that can support the machine weight and operator.

Do not operate the machine on a ramp incline that exceeds a 19.5% grade level. Use tie-down straps to secure machine to truck or trailer.

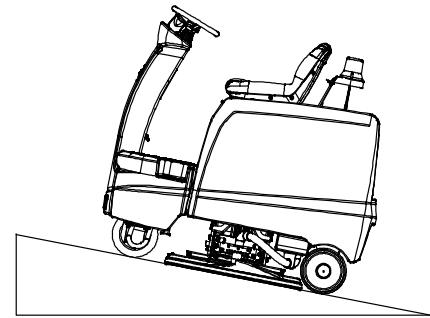

19.5% maximum ramp grade

FIG. 57

3. Once loaded, position the front of the machine up against the front of the trailer or truck. Lower the burnishing head to the floor and turn the key off (Figure 58).
4. Place a block behind each wheel (Figure 58).
5. Secure the front and rear of the machine with tie-down straps (Figure 58). Route the front strap through the stabilizer arms (U-shape bars). Route the rear strap above the rear axle at center. It may be necessary to install tie-down brackets to the floor of your trailer or truck.

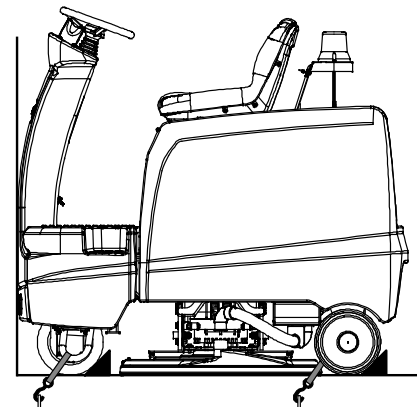

FIG. 58

STORING MACHINE

The following steps should be taken when storing the machine for extended periods of time.

1. Raise burnishing head in the transport position.
2. Park the machine in a cool, dry area. Do not expose the machine to rain. Store indoors.

NOTE: To prevent potential machine damage store machine in a rodent and insect free environment.

3. Remove the batteries, or charge them every three months.

SECTION 4

Contents	Page
TROUBLESHOOTING	
CONFIGURATION MODES	4-2
HEAD SELECT MODE	4-2
BATTERY SELECT MODE	4-3
BURNISH PROPEL SPEED	
SELECT MODE	4-3
REVERSE ALARM SELECT MODE.....	4-4
DOWN PRESSURE SELECT MODE.....	4-4
SUPERVISOR MODE.....	4-5
ACTIVE DUST CONTROL	
SETUP MODE	4-6
DIAGNOSTIC MODES	4-7
DISPLAY SOFTWARE	
REVISION MODE	4-7
SELF-TEST MODE	4-7
MANUAL MODE	4-9
INPUT DISPLAY MODE	4-9
PROPEL DIAGNOSTICS MODE.....	4-11
FAULTS	4-13
BATTERY CHARGER	4-17
SUBSYSTEM TROUBLESHOOTING	4-18
BACK-UP ALARM	4-18
BATTERY CHARGER (ON BOARD).....	4-20
BATTERY CHARGER (OFF BOARD).....	4-22
PARKING BRAKE,	
ELECTROMAGNETIC	4-24
BURNISH MOTOR	4-26
POWER-UP CIRCUIT.....	4-28
PROPEL.....	4-30
BURNISH HEAD LIFT	4-32
ADC (ACTIVE DUST CONTROL).....	4-34

TROUBLESHOOTING

CONFIGURATION MODES

Configuration Modes are onboard software utilities that configure the controller to operate optional equipment and to electronically adjust certain output functions. The configuration modes are:

- *Head Select Mode*
- *Battery Select Mode*
- *Burnish Propel Speed Select Mode*
- *Reverse Alarm Select Mode*
- *Down Pressure Select Mode*
- *Supervisor Mode*
- *Active Dust Control Setup Mode*

HEAD SELECT MODE

This mode allows the controller to be configured for the 24 in(61 cm) or 27 in(69 cm) burnish head.

1. Press and hold the (-) decrease down pressure and decrease propel speed buttons while turning on the key switch. Release the buttons after 10 seconds.

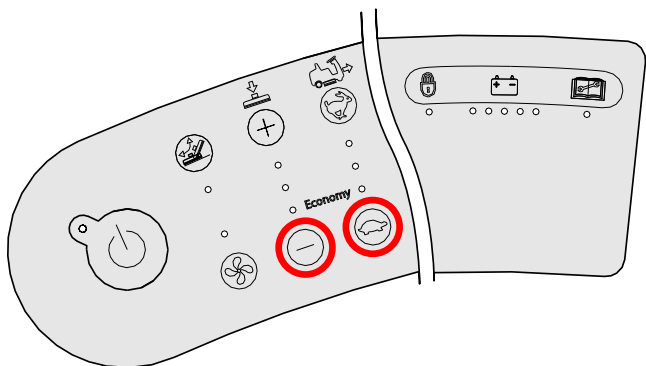

2. Observe the down pressure LEDs. Down pressure LED #1 indicates a 24 in(61 cm) configuration or LED #3 indicates a 27 in(69 cm) configuration.

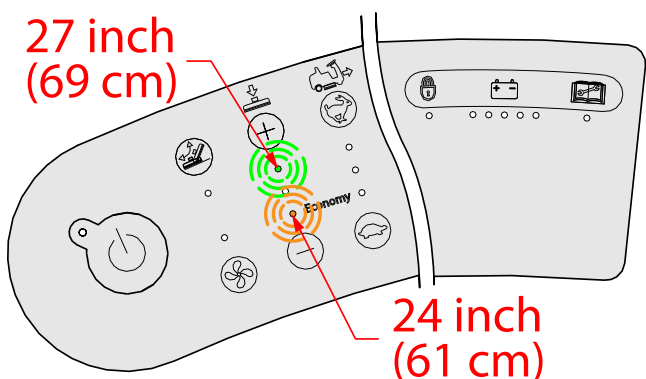

3. Press the down pressure (-) button to select the 24 in (61 cm) head or press the down pressure (+) button to select the 27 in(69 cm) head.

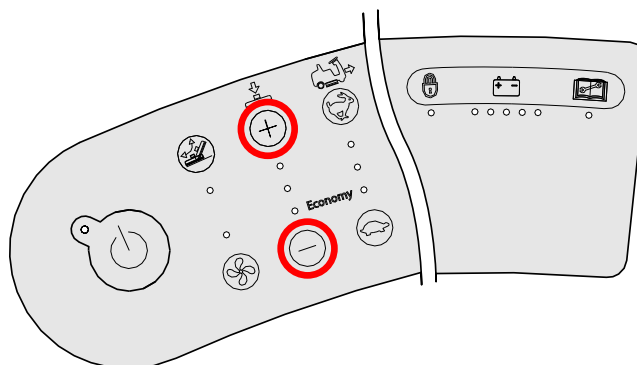

4. Turn the key OFF to save the selection.

BATTERY SELECT MODE

This mode allows the controller to be configured for different types of batteries, which affects BDI (battery discharge indicator) operation.

1. Press and hold the increase propel speed button while turning on the key switch. Release the button after 10 seconds.

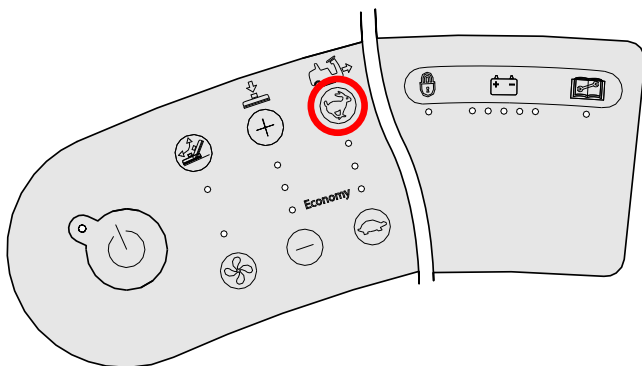

2. Observe the battery gauge LEDs. Each LED indicates a specific battery-type selection.

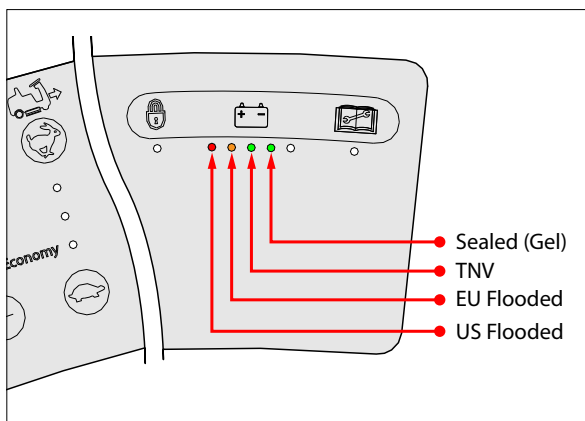

3. Press the decrease propel speed button to scroll to the desired battery selection.

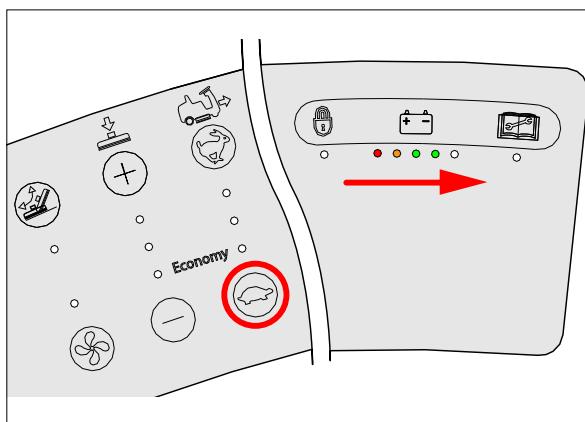

4. Turn the key OFF to save the selection.

NOTE: Changing the battery selection will effect BDI (battery discharge indicator) operation. Use the table below to determine BDI segment illumination voltages for each battery type. The voltage values were measured at the circuit board.

BDI LED	US Flooded	EU Flooded	TNV	Sealed (Gel)
#5	36.8 volts	36.8 volts	36.8 volts	36.8 volts
#4	35.2 volts	35.9 volts	35.9 volts	36 volts
#3	34.7 volts	34.8 volts	35 volts	35.3 volts
#2	33.6 volts	33.9 volts	34.1 volts	34.5 volts
#1	32.6 volts	32.9 volts	33.2 volts	33.9 volts
#1*	31.2 volts	32.0 volts	32.4 volts	33.3 volts

*Indicates flashing red LED. Others are steady.

BURNISH PROPEL SPEED SELECT MODE

This mode allows for changes to burnish propel speed ranges. The default setting is medium and can be changed to the Low or High Range settings.

1. Press and hold the (+) increase down pressure and decrease propel speed buttons while turning on the key switch. Release the buttons after 10 seconds.

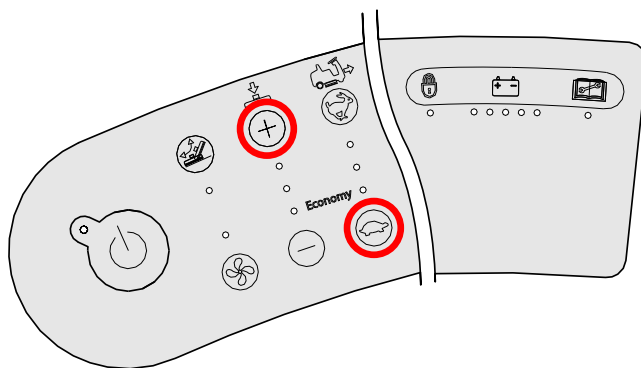

TROUBLESHOOTING

2. Observe the propel speed LEDs. Each LED indicates a speed range; Low, Medium (default), or High.

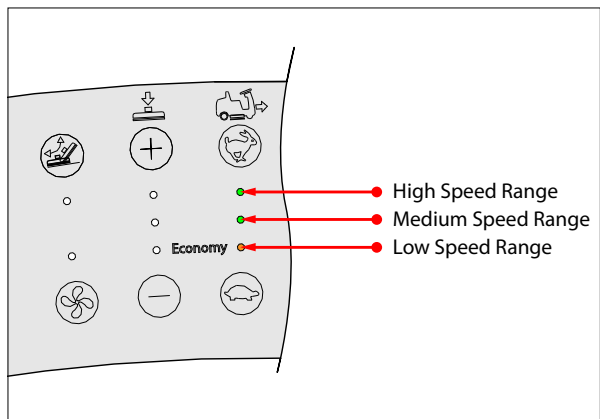

3. Press the propel speed increase or decrease buttons to change to the desired propel speed range.

NOTE: Reverse propel speed will always be approximately 60% of forward propel speed. See the table below for approximate burnishing speeds within each speed range.

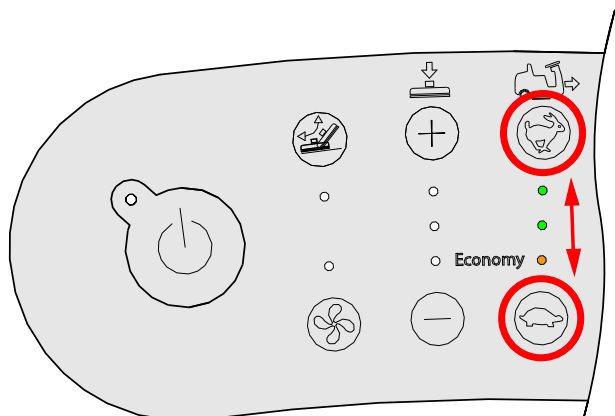

Burnish Speed	Low Range	Med Range	High Range
1 LED	125 fpm	150 fpm	175 fpm
2 LEDs	150 fpm	175 fpm	200 fpm
3 LEDs	250 fpm	275 fpm	300 fpm

fpm = feet per minute

4. Turn the key OFF to save the selection.

REVERSE ALARM SELECT MODE

This mode allows the reverse alarm to be disabled in operating environments where alarms are not allowed (e.g. hospitals, quiet work space, etc.). The default setting is ON.

1. Place the directional switch in the reverse position and press and hold the horn button for approximately 10 seconds while turning on the key switch. If the reverse alarm was disabled, then the reverse alarm will sound indicating that the reverse alarm is now enabled. If the reverse alarm was already enabled, then the reverse alarm will not sound indicating that the reverse alarm is now disabled.



2. Turn the key OFF to save the selection.

DOWN PRESSURE SELECT MODE

This mode allows for down pressure changes required with varying floor conditions or floor chemical systems.

1. Press and hold the (+) increase and (-) decrease down pressure buttons while turning on the key switch. Release the buttons after 10 seconds.

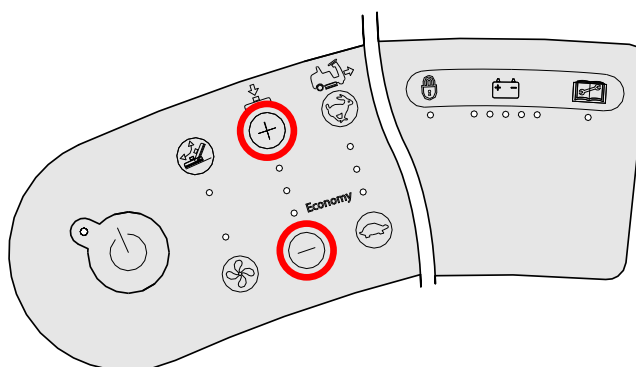

2. Observe the down pressure LEDs. Each LED indicates a specific down pressure *range*; Low, Medium (Default), or High.

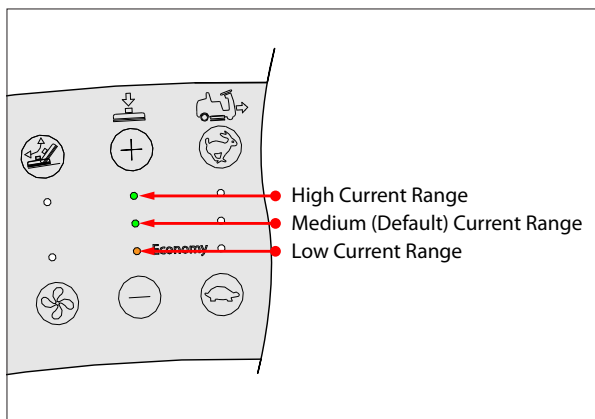

3. Press the (-) decrease or (+) increase down pressure buttons to change to the desired down pressure *range* setting.

NOTE: Refer to the target burnish motor current values in the table below for each down pressure setting within each down pressure range.

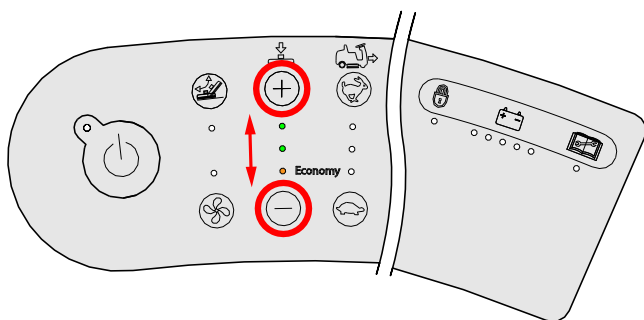

Head Size 24 in(61 cm)	Low Range	Med Range	High Range
1 LED	65 Amps	70 Amps	75 Amps
2 LEDs	73 Amps	78 Amps	83 Amps
3 LEDs	80 Amps	85 Amps	90 Amps

Head Size 27 in(69 cm)	Low Range	Med Range	High Range
1 LED	65 Amps	70 Amps	75 Amps
2 LEDs	73 Amps	78 Amps	83 Amps
3 LEDs	80 Amps	85 Amps	90 Amps

4. Turn the key OFF to save the selection.

SUPERVISOR MODE

This mode allows supervisors to restrict active dust control, down pressure and propel speed settings.

1. Press and hold the (+) increase down pressure and increase propel speed buttons while turning on the key switch. Release the buttons after 10 seconds.

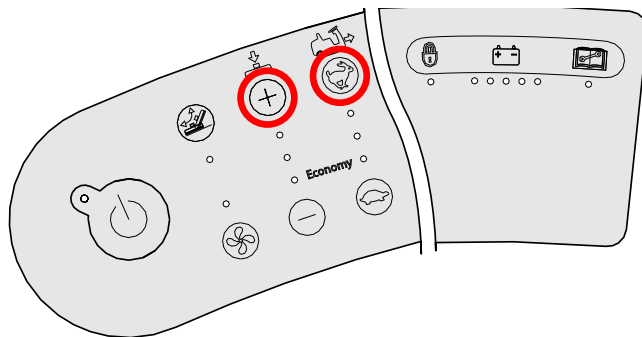

2. Observe BDI (battery discharge indicator) LEDs #1 and #3. If the #1 red LED is flashing, supervisor mode is disabled. If the #3 green LED is flashing, supervisor mode is enabled. Repeat Step 1 to toggle in/out of supervisor mode.

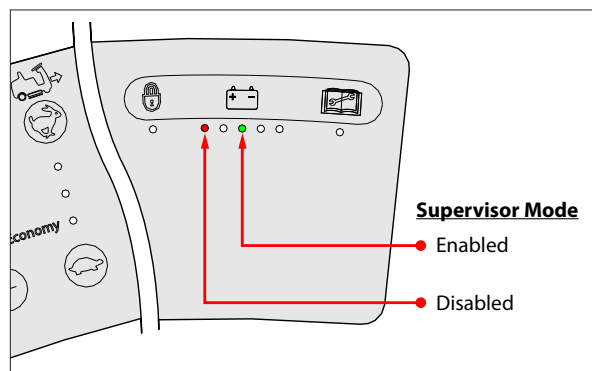

3. Observe the vacuum LED. If the vacuum LED is ON, active dust control is enabled automatically during normal burnish mode. If the vacuum LED is OFF, active dust control is not enabled automatically. Press the vacuum button to toggle this setting.
NOTE: Must be configured for ADC.

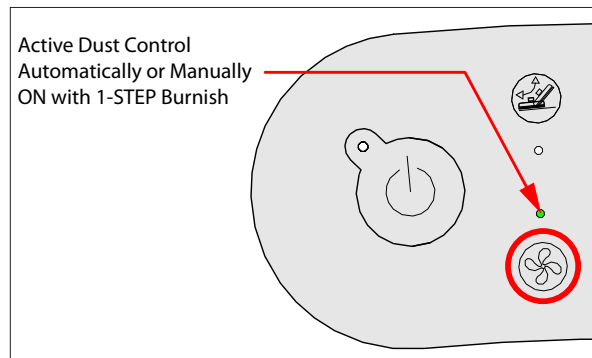

TROUBLESHOOTING

4. Observe the down pressure and propel speed LEDs. Increase or decrease the maximum down pressure and/or propel speed to set the fixed-maximum adjustments in normal burnish mode.
2. Press the vacuum button to toggle ADC ON/OFF. The vacuum LED indicates whether ADC is ON/OFF.

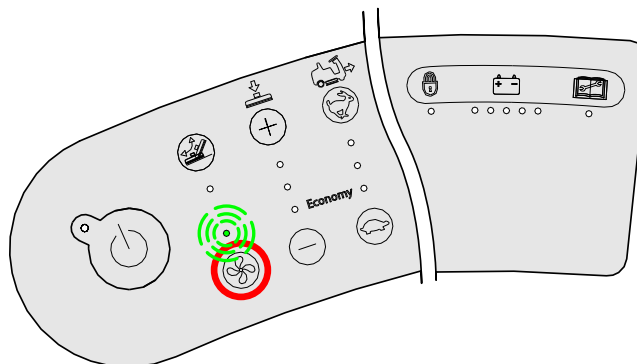
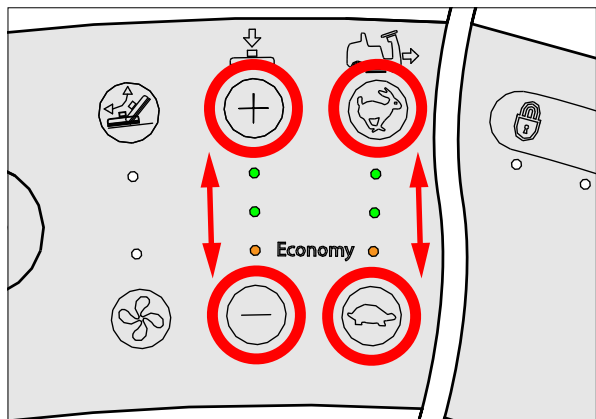

3. Turn the key OFF to save the selection.

NOTE: When supervisor mode is enabled, the vacuum, down pressure, and propel speed buttons will not be operational. The supervisor (lock) LED will flash if these buttons are pressed.

NOTE: Decreasing to zero LEDs for down pressure or propel speed in supervisor mode will exclude that function from supervisor mode (i.e. no restrictions for that function). This allows for restrictions to one function and not the other.

5. Turn the key OFF to save the selection.

ADC (ACTIVE DUST CONTROL) SETUP MODE

This mode configures the controller for the optional active dust control feature.

1. Press and hold the vacuum button while turning on the key switch. Release the button after 10 seconds. The vacuum LED flashes for approximately 2 seconds while entering ADC mode and continues to flash if ADC was enabled or turns OFF if ADC was disabled.

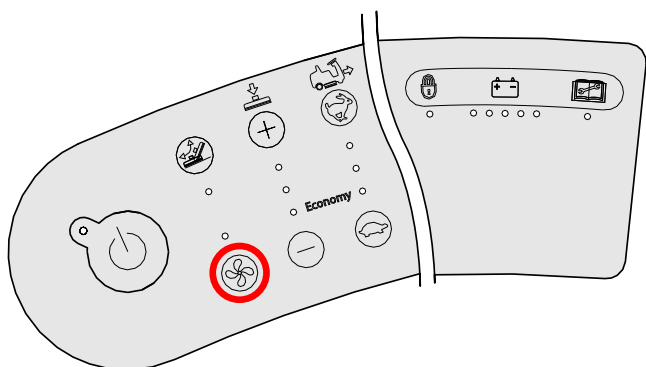

DIAGNOSTIC MODES

Diagnostic Modes are onboard software utilities that service technicians can use to diagnose machine failures. The diagnostic modes are:

- Display Software Revision Mode
- Self-Test Mode
- Manual Mode
- Input Display Mode
- Propel Diagnostics Mode

DISPLAY SOFTWARE REVISION MODE

This mode allows service technicians to verify the software revision date.

1. Press and hold the 1-STEP burnish button while turning on the key switch. Release the button after 10 seconds.

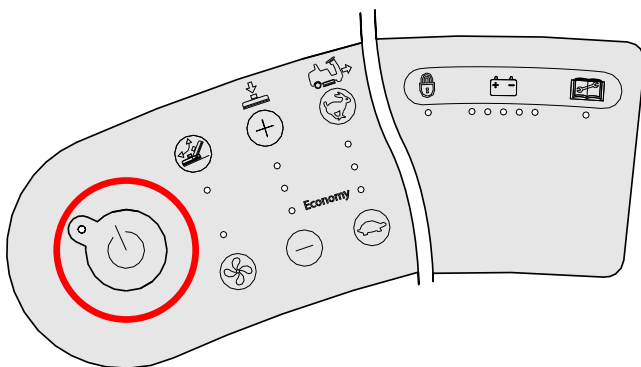

2. Observe and count the flashing down pressure and propel speed LEDs and use the diagram below to determine the software date.

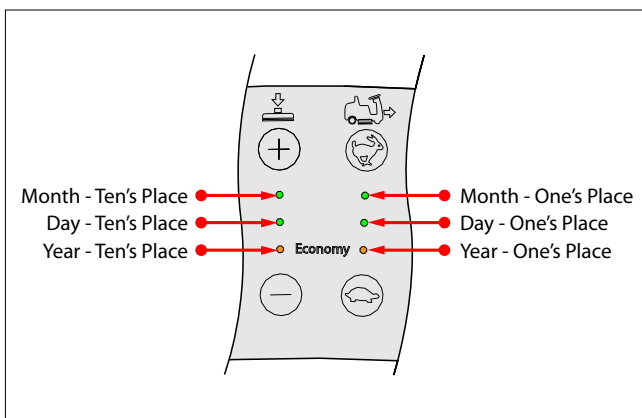

SELF-TEST MODE

This mode allows service technicians to initiate a control board output circuit test. The results are not necessarily pass/fail, but open or shorted. An open circuit has infinite resistance and a shorted circuit has approximately zero resistance. The results are displayed using touch panel LEDs.

NOTE: There is 10-15 second delay between self-test initiation and main burnish motor activation.

1. Press and hold the increase propel speed and (-) decrease down pressure buttons while turning on the key switch. Release the buttons after 10 seconds.

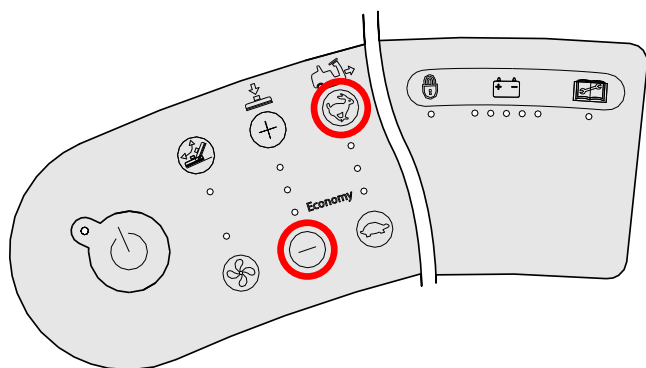

2. Self-test mode is active when battery LED #5 illuminates.

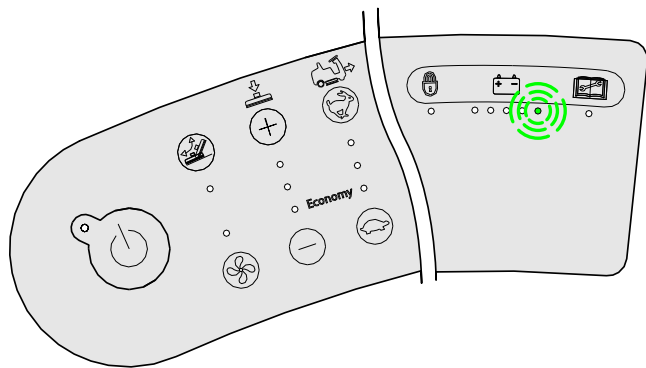

3. The controller sequentially tests each output circuit as shown below.

Step	Circuit Description	Output Pin(s)
1	Burnish Head Actuator	J6-4
2	Burnish Motor Contactor	J6-21, J6-23
3	Parking Brake	J6-25
4	Active Dust Control (Option)	J9-1, J9-2
5	Horn	J6-15

TROUBLESHOOTING

4. The 1-STEP LED illuminates if system passes or detects no open or shorted circuits. The other LEDs illuminate to display open or shorted output circuits. Use the diagram below to determine self-test results.

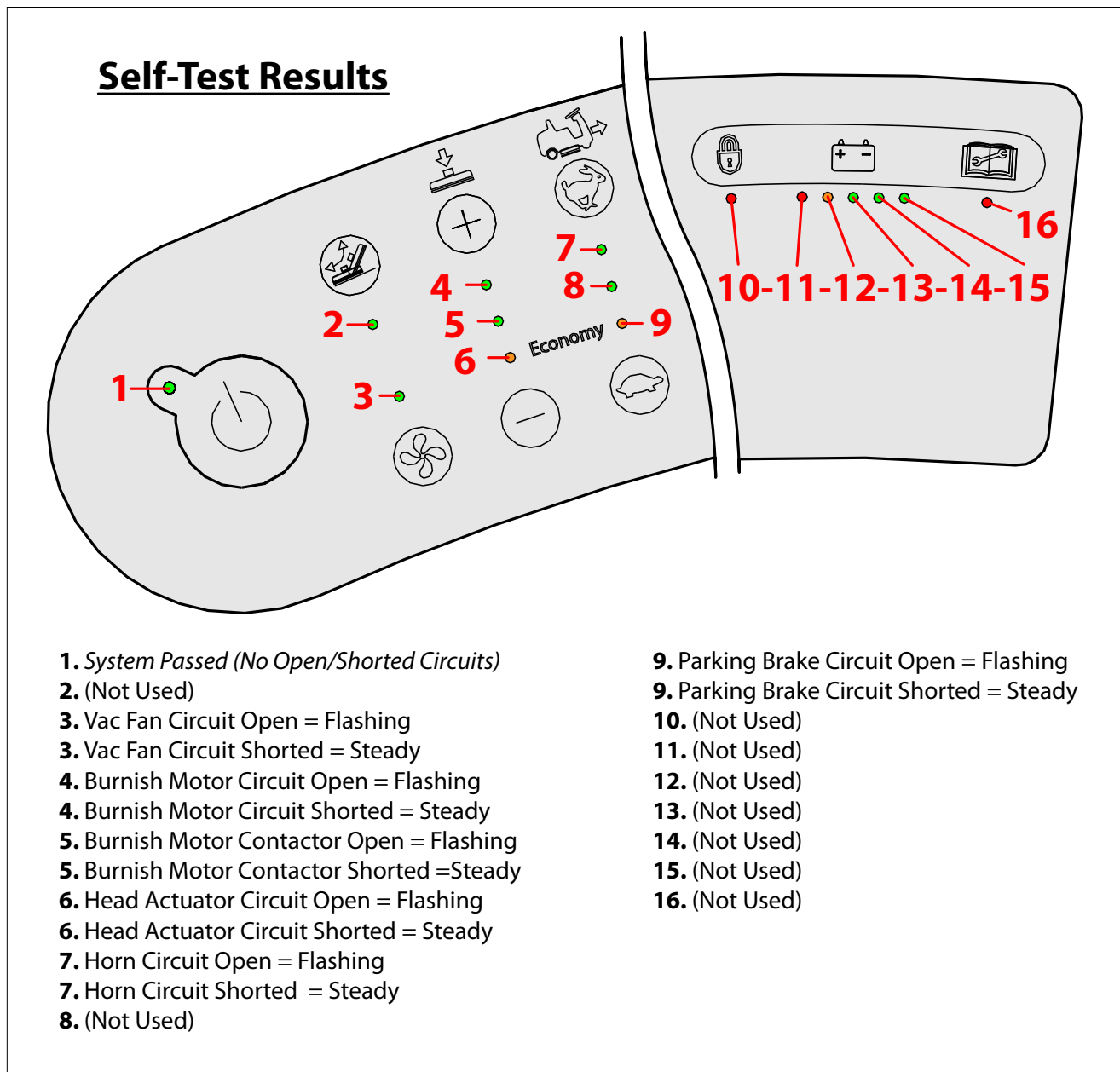

5. Turn the key switch OFF to exit *self-test mode*.

MANUAL MODE

This mode allows service technicians to operate controller outputs manually for testing or service purposes.

1. Press and hold the (-) decrease down pressure button while turning on the key switch. Release the button after 10 seconds.

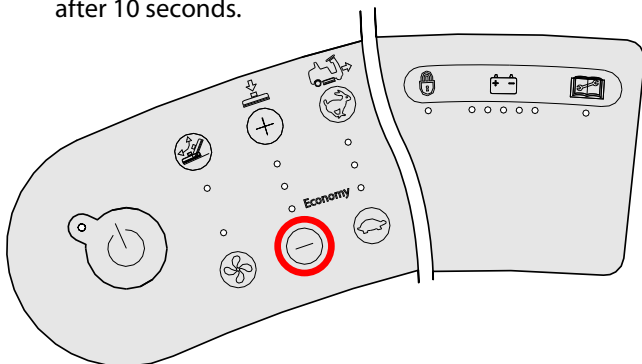

2. *Manual mode* is active when down pressure LED #1 begins to flash.

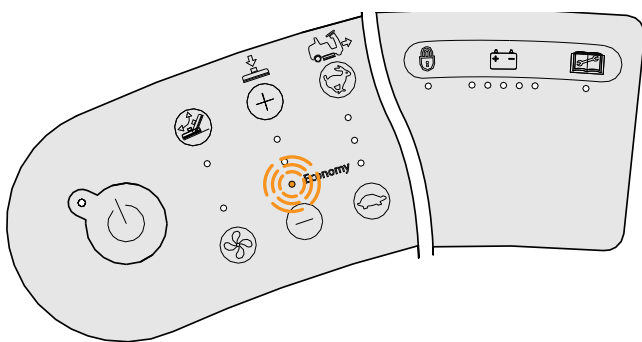

3. Use the table below to determine which button activates supported outputs in *manual mode*.

Button	Output (Function)
(+) Increase Down Pressure	Lowers the Burnish Head (momentary)
(-) Decrease Down Pressure	Raises the Burnish Head (momentary)
1-STEP Burnish	Burnish Motor (on/off)
Active Dust Control Vacuum	Vacuum Fan Motor (on/off)

4. Turn the key switch OFF to exit *manual mode*.

INPUT DISPLAY MODE

This mode allows service technicians to observe conditional control board inputs using touch panel LEDs.

1. Press and hold the decrease propel speed button while turning on the key switch. Release the button after 10 seconds.

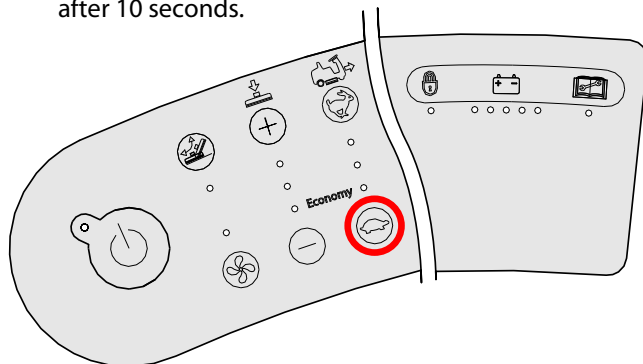

2. *Input display mode* is active when BDI (battery discharge indicator) LED #4 begins to flash.

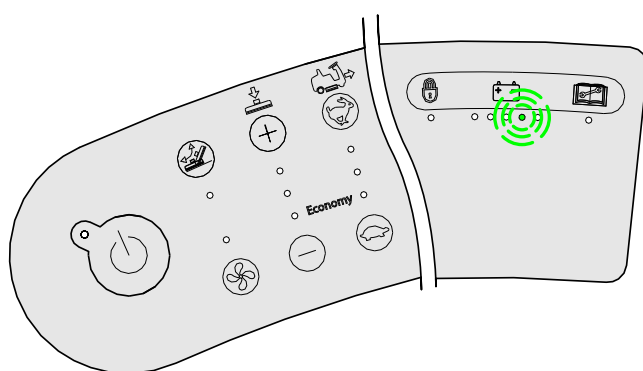

TROUBLESHOOTING

3. Use the diagram below to determine the condition of supported controller inputs.

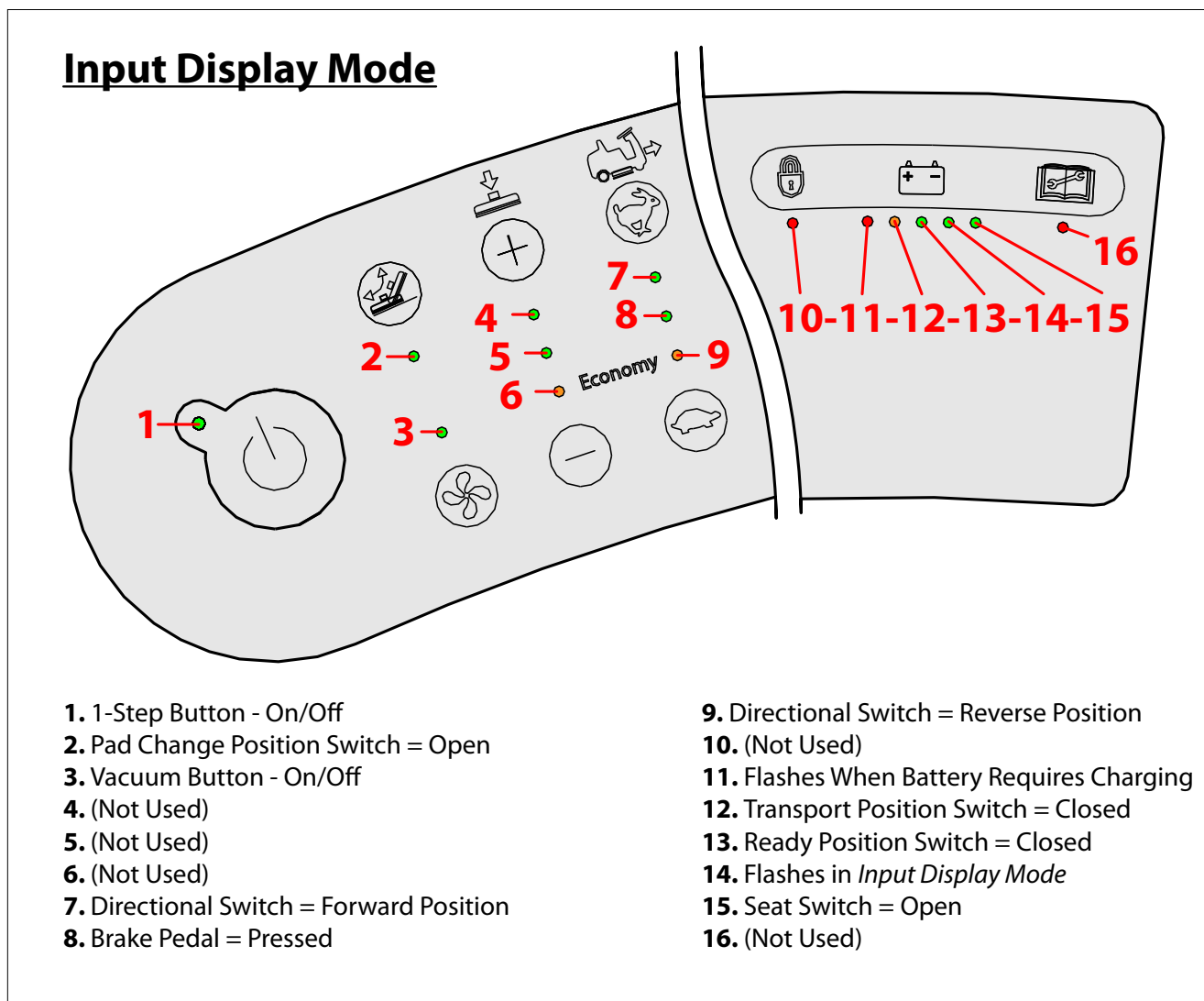

4. Turn the key switch OFF to exit *input display mode*.

PROPEL DIAGNOSTICS MODE

This mode allows service technicians to observe conditional propel system inputs as well as certain propel system settings.

1. Press and hold the (+) increase down pressure and pad change buttons while turning on the key switch. Release the buttons after 10 seconds.

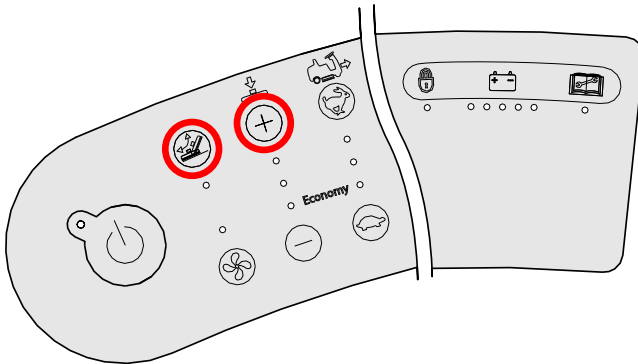

2. *Propel diagnostics mode* is active when BDI (battery discharge indicator) LED #5 begins to flash.

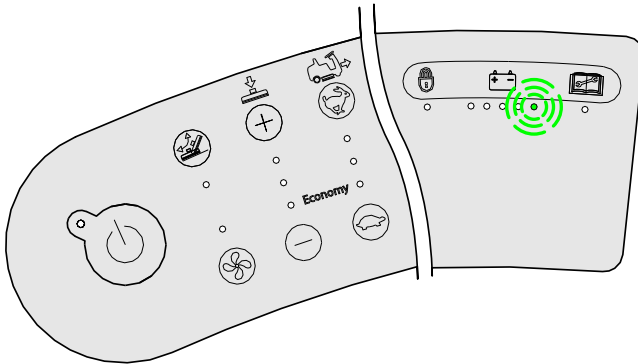

TROUBLESHOOTING

3. Use the diagram below to determine the condition of supported propel system inputs and settings.

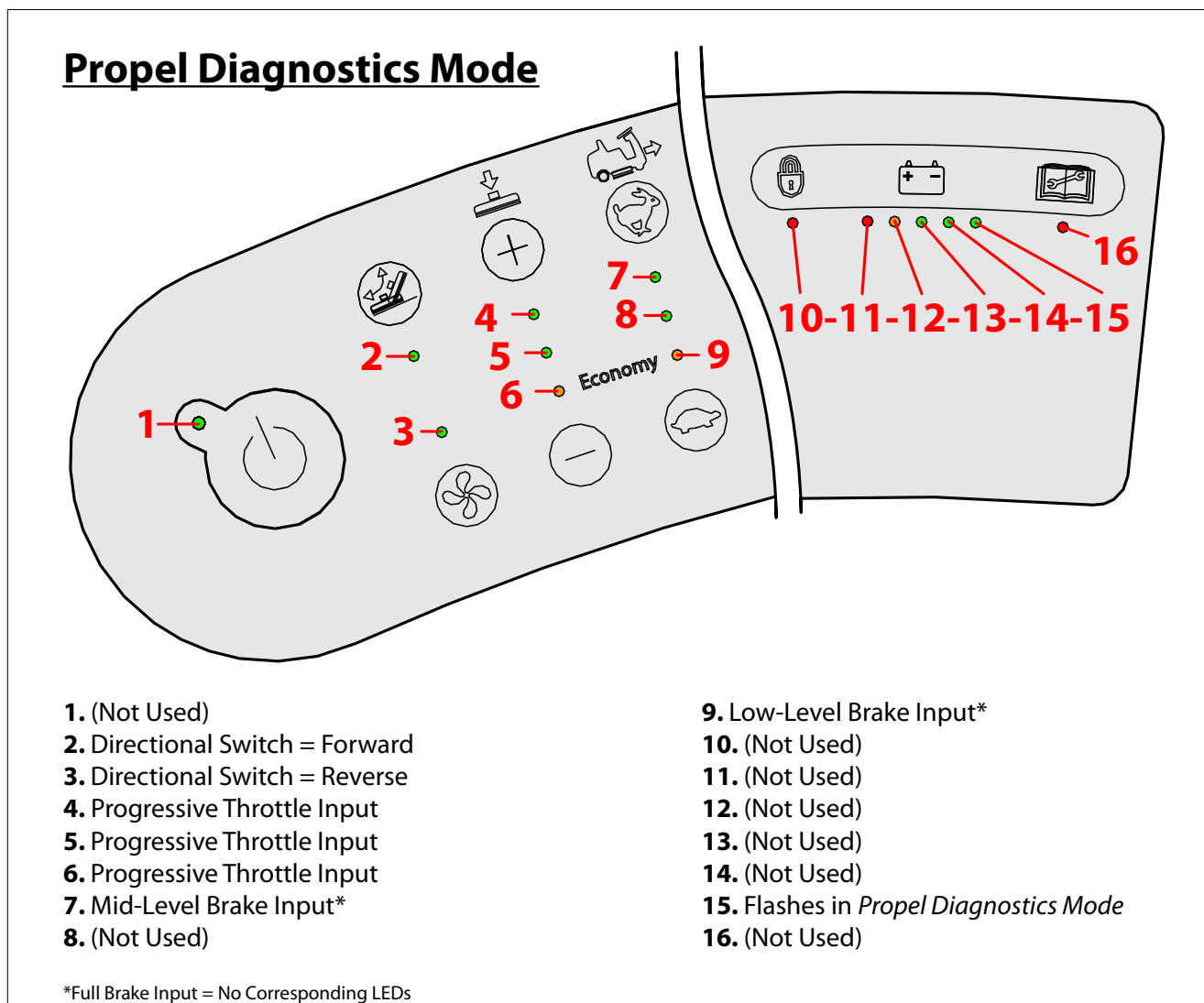

4. Turn the key switch OFF to exit *propel diagnostics mode*.

SpeedGleam Rider Faults

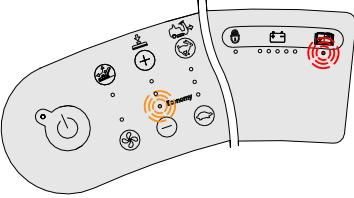
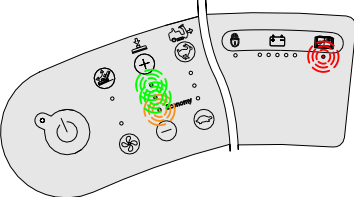
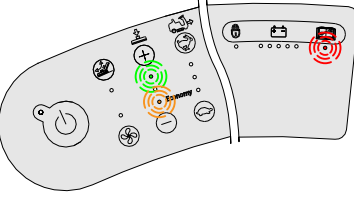
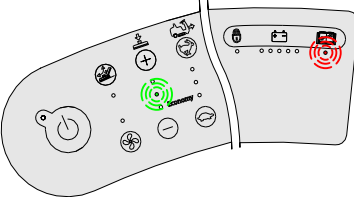
LED FAULT DISPLAY/ AUDIBLE	FAULT DESCRIPTION	SET/CLEAR
 <ul style="list-style-type: none"> • Fault LED ON (Flashing) • Down Pressure LED #1 ON (Flashing) 	<p>Actuator Over Current</p>	<p><i>SET:</i> Head lift actuator motor current > 6 Amps for 15 seconds. <i>CLEAR:</i> Correct fault condition and cycle key switch.</p>
 <ul style="list-style-type: none"> • Fault LED ON (Flashing) • Down Pressure LEDs #1 and 2 ON (Flashing) 	<p>Actuator Under Current</p>	<p><i>SET:</i> Head lift actuator motor current < 0.5 Amps for 1 minute. <i>CLEAR:</i> Correct fault condition and cycle key switch.</p>
 <ul style="list-style-type: none"> • Fault LED ON (Flashing) • Down Pressure LEDs #1 and 3 ON (Flashing) 	<p>Actuator Timeout</p>	<p><i>SET:</i> Head lift actuator time > 25 seconds to move to a destination location. <i>CLEAR:</i> Correct fault condition and cycle key switch or press the 1-STEP Burnish button.</p>
 <ul style="list-style-type: none"> • Fault LED ON (Flashing) • Down Pressure LED#2 ON (Flashing) 	<p>Burnish Motor Contactor Over Current</p>	<p><i>SET:</i> Burnish motor contactor coil circuit is shorted. <i>CLEAR:</i> Correct fault condition and cycle key switch.</p>

FMM001





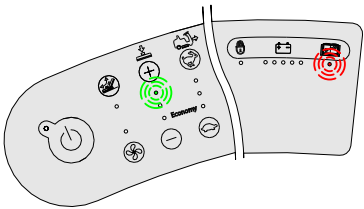
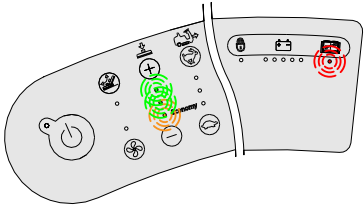
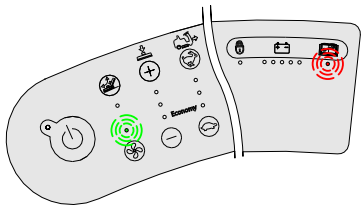

TROUBLESHOOTING

SpeedGleam Rider Faults, continued

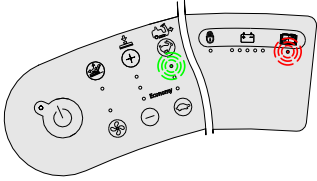
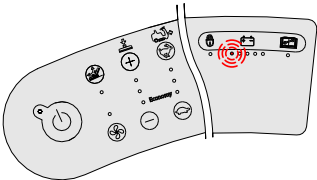
LED FAULT DISPLAY/ AUDIBLE	FAULT DESCRIPTION	SET/CLEAR
 <ul style="list-style-type: none"> • Fault LED ON (Flashing) • Down Pressure LED#3 ON (Flashing) 	<p>Burnish Motor Over Current</p>	<p><i>SET:</i> Burnish motor current > 125 Amps for 5 minutes. Or, > 135 Amps for 2 minutes. Or, > 145 Amps for 15 seconds. <i>CLEAR:</i> Correct fault condition and cycle key switch.</p>
 <ul style="list-style-type: none"> • Fault LED ON (Flashing) • Down Pressure LEDs #1, 2, and 3 ON (Flashing) 	<p>Burnish Motor Under Current</p>	<p><i>SET:</i> Burnish motor current is < target current for 1 minute (see the <i>Specifications</i> section of this manual for target current specifications). <i>CLEAR:</i> Correct fault condition and cycle key switch.</p>
 <ul style="list-style-type: none"> • Fault LED ON (Flashing) • Vacuum LED ON (Flashing) 	<p>Vacuum Motor Over Current</p>	<p><i>SET:</i> Vacuum motor current > 5 Amps for 5 minutes. Or, > 7 Amps for 2 minutes. Or, > 9 Amps for 15 seconds. <i>CLEAR:</i> Correct fault condition and cycle key switch.</p>

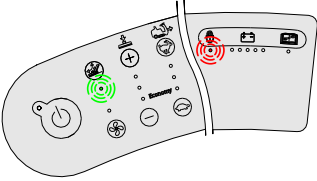
FMM001_2

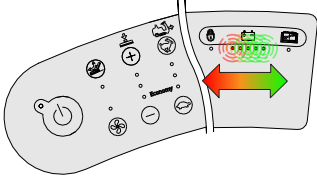





SpeedGleam Rider Faults, continued

LED FAULT DISPLAY/ AUDIBLE	FAULT DESCRIPTION	SET/CLEAR
 <ul style="list-style-type: none"> • Fault LED ON (Flashing) • Propeller Speed LED #3 ON (Flashing) 	<p>Propeller Interlock - Over Current</p>	<p><i>SET:</i> Propeller motor current > 50 Amps for 15 minutes. Or, > 65 Amps for 6 minutes. Or, > 78 Amps for 4 minutes. <i>CLEAR:</i> Correct fault condition and cycle key switch.</p>
 <ul style="list-style-type: none"> • BDI (Battery Discharge Indicator) LED #1 (Flashing) 	<p>Low Battery</p>	<p><i>SET:</i> Battery voltage < 31.2 volts (US Flooded), < 31.95 volts (EU Flooded), < 32.4 volts (TNV), or < 33.3 volts (Sealed Gel). <i>CLEAR:</i> Recharge batteries and cycle key switch.</p>
<p>2 Audible Beeps (repeating) </p>	<p>Propeller Interlock - Seat Switch Open</p>	<p><i>SET:</i> Forward or reverse throttle input when seat switch is open. <i>CLEAR:</i> Release throttle pedal back to neutral.</p>
 <ul style="list-style-type: none"> • Pad Change LED ON (Flashing) • Supervisor LED ON (Flashing) <p>3 Audible Beeps (Repeating) </p>	<p>Propeller Interlock - Pad Change Mode</p>	<p><i>SET:</i> Forward/Reverse throttle input while in pad change mode. <i>CLEAR:</i> Release throttle pedal back to neutral.</p>
 <ul style="list-style-type: none"> • BDI (Battery Discharge Indicator) LEDs #1-2-3-4-5 (Ripple) <p>4 Audible Beeps (Repeating) </p>	<p>Propeller Interlock - (HPD) High Pedal Disable</p>	<p><i>SET:</i> Forward or reverse throttle input present during power up cycle. <i>CLEAR:</i> Correct fault condition and cycle key switch.</p>

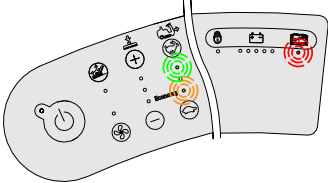
FMM002

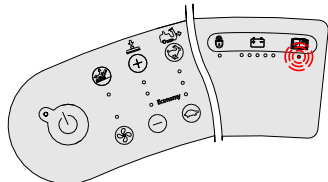
TROUBLESHOOTING

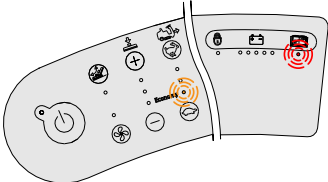
SpeedGleam Rider Faults, continued

LED FAULT DISPLAY/ AUDIBLE	FAULT DESCRIPTION	SET/CLEAR
 <ul style="list-style-type: none"> • Fault LED ON (Flashing) • Propel Speed LEDs #1 and 3 ON (Flashing) <p>5 Audible Beeps (Repeating) </p>	<p>Propel Interlock - Throttle Fault</p>	<p><i>SET:</i> Throttle pedal circuit is open. <i>CLEAR:</i> Correct fault condition and cycle key switch.</p>
 <ul style="list-style-type: none"> • Fault LED ON (Flashing) <p>6 Audible Beeps (Repeating) </p>	<p>Propel Interlock - Brake Fault</p>	<p><i>SET:</i> Brake pedal circuit is open. <i>CLEAR:</i> Correct fault condition and cycle key switch.</p>
 <ul style="list-style-type: none"> • Fault LED ON (Flashing) • Propel Speed LED #1 ON (Flashing) <p>7 Audible Beeps (Repeating) </p>	<p>Propel Interlock - Parking Brake Open</p>	<p><i>SET:</i> EM (electro-magnetic) parking brake circuit is open/shorted. <i>CLEAR:</i> Correct fault condition and cycle key switch.</p>
<p>9 Audible Beeps (Repeating) </p>	<p>Propel Interlock - Charger Interlock</p>	<p><i>SET:</i> Battery charger interlock switch is open. <i>CLEAR:</i> Disconnect charger and cycle key switch.</p>

FMM002_2

Battery Charger, Onboard (Option)

OPERATION

The onboard battery charger utilizes a 4 character digital display, 3 control indicator LEDs and a scroll button. The red control indicator illuminates at the beginning of the charging cycle. The yellow control indicator illuminates when the final phase of the charging cycle begins and the green control indicator illuminates when the charging cycle is complete.

Each time the battery charger is connected to an AC power supply, the charger displays; "SPE," the software revision date, battery voltage, charging current, charging curve number, and finally the words "GEL" (Gel) or "Acd" (Lead-Acid) depending on how the charger is configured from the factory.

Pressing the scroll button during the charge cycle will change the display mode between; A (charging current), U (battery voltage), h (charging time), C (charging amp-hours), and E (energy used KWh).

CONFIGURATION, LEAD ACID/AGM

1. Key Off. Disconnect battery charger from AC power supply and the batteries.
2. Carefully remove the charger display cover decal to access the programmable dip switches.
3. Use the table below to set the dip switches for Flooded Lead-Acid or AGM batteries.

NOTE: The dip switches below are shown in the default Lead-Acid position.

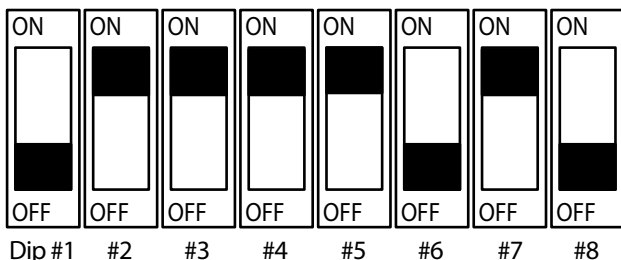

OBC005

TYPE	#1	#2	#3	#4	#5	#6	#7	#8
Flooded	OFF	ON	ON	ON	ON	OFF	ON	OFF
AGM	ON	OFF	OFF	OFF	ON	OFF	ON	OFF

FAULTS

Fault messages automatically display when a fault exists. Use the table below to identify possible causes.

FAULT	POSSIBLE CAUSE
"bat"	Poor or no battery connection or reversed polarity
"E01"	Maximum battery voltage exceeded.
"E02"	Maximum battery temperature exceeded.
"E03"	Maximum charging time exceeded.
"Sct"	The total safety timer has interrupted charging.
"Srt"	Internal charger short circuit possible.

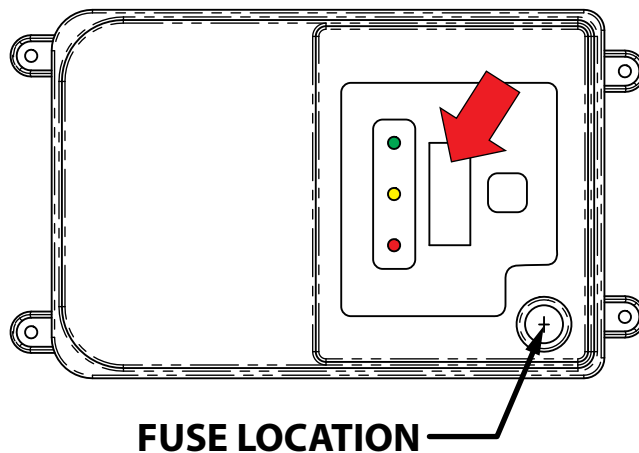

TROUBLESHOOTING

Back-Up Alarm ON

Note: Key Switch ON

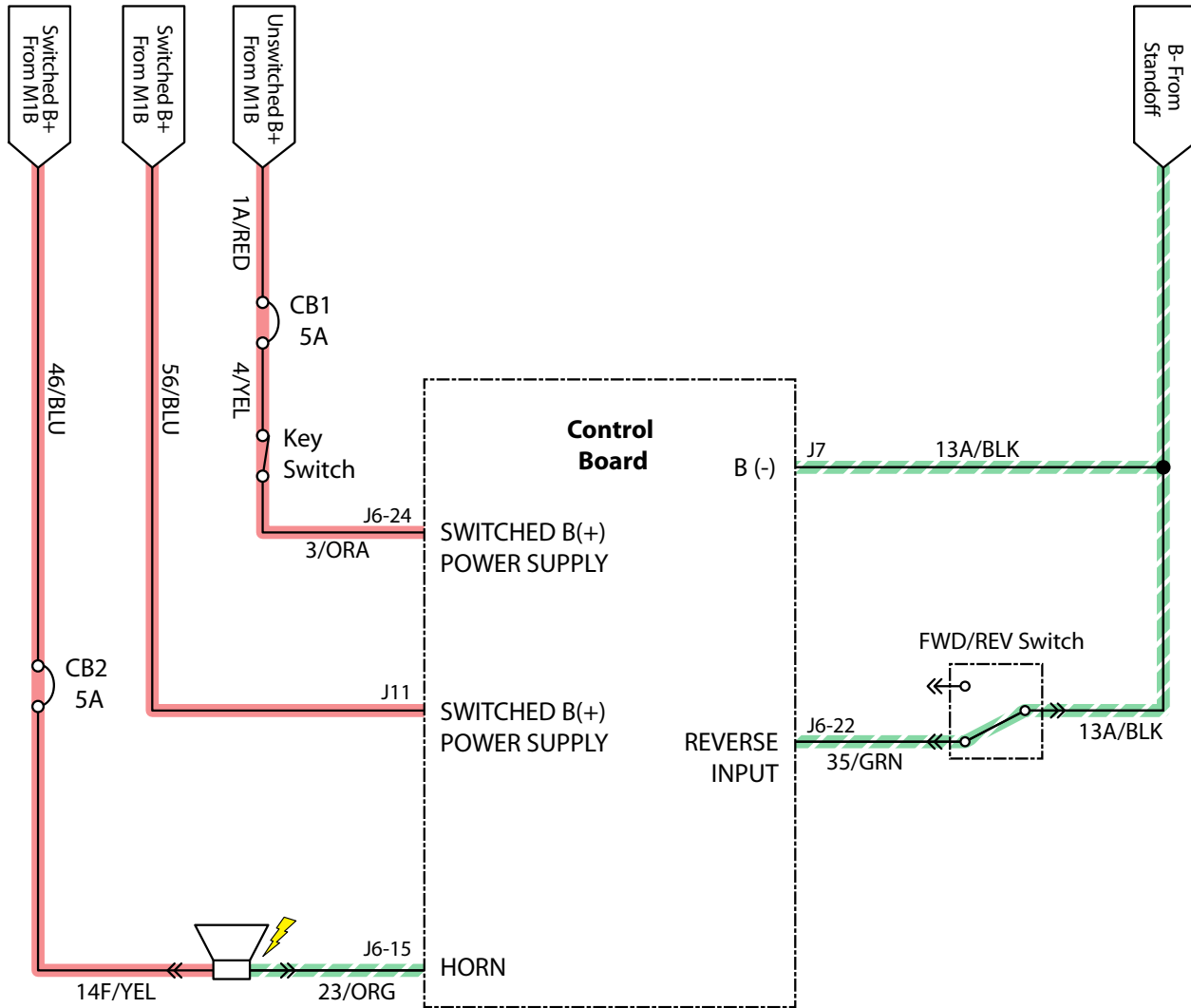

- Battery Positive +
- Battery Negative -

PMC011

Operational Matrix:		
	Enabled	Disabled
Back-Up Alarm	<ul style="list-style-type: none"> • Rev Switch Input 	<ul style="list-style-type: none"> • Fwd Switch Input • Hospital Mode - Silent • Load Current Fault

Back-Up Alarm Failed to Turn ON

STEP	ACTION	VALUE(S)	YES	NO
1	<ul style="list-style-type: none"> • Key On • Enable back-up alarm • Is there an audible fault present? 		See "SpeedG-learn Faults" in the Troubleshooting section of this manual	Go to Step #2
2	<ul style="list-style-type: none"> • Key Off • See "Self-Test Mode" • Does the Self-Test display the horn output circuit as open or shorted? 		Correct Open or Short Circuit Condition	Go to Step #3
3	<ul style="list-style-type: none"> • Key Off • See "Propel Diagnostic Mode" • Check the Forward/Reverse switch inputs from the directional switch using the touch panel LEDs • Are the forward and reverse inputs operating properly? 		Go to Step # 4	Correct Faulty Input Condition
4	<ul style="list-style-type: none"> • Key Off • Disconnect back-up alarm from main harness • Apply battery voltage to back-up alarm using fuse-protected jumper leads • Does the back-up alarm turn On? 		Go to Step #5	Replace Back-Up Alarm
5	<ul style="list-style-type: none"> • Reconnect back-up alarm to main harness • Key On • Enable back-up alarm • Test voltage applied to the back-up alarm as shown on the electrical schematic • Are the electrical circuits operating as shown on the electrical schematic? 		Go Back to Step #1	Identify Voltage Drop Location and Repair or Replace Necessary Components

Terms:

Backprobe = To insert voltmeter probe(s) into the back of a connector to contact a terminal(s) while the circuit operates or should be operating.

LED = Light Emitting Diode

VDC = DC Voltage

TROUBLESHOOTING

Onboard Battery Charging ON

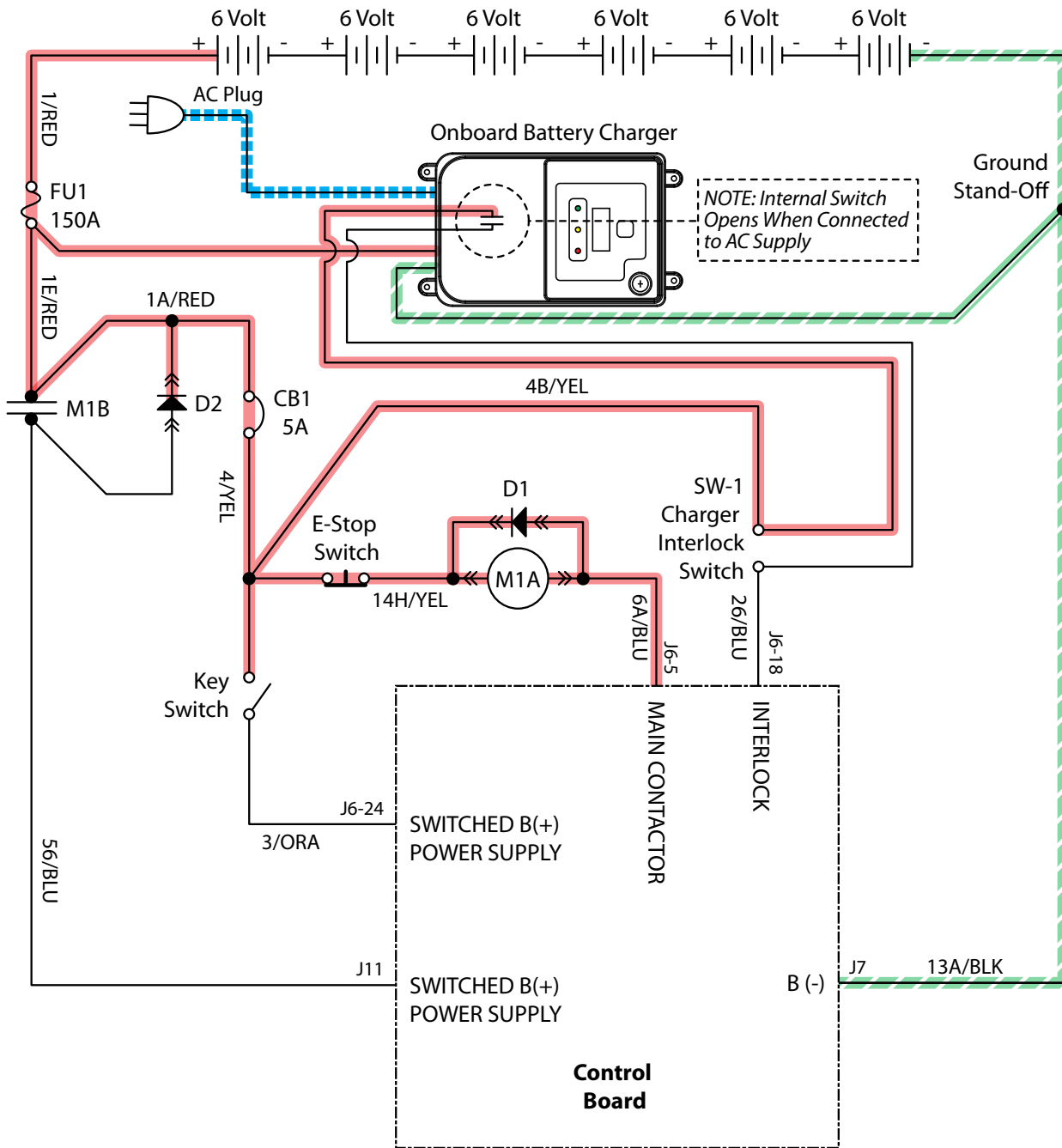

- Battery Positive +
- Battery Negative -
- AC Volts

NOTE: Battery charger interlock harness connects to main harness SW-1 interlock connection.

PMC021

Batteries Failed to Charge

STEP	ACTION	VALUE(S)	YES	NO
1	<ul style="list-style-type: none"> • Key Off • Is there a pertinent fault displayed on the onboard charger (bat, E01, E02, E03, SCt, or Srt)? 		See "Onboard Battery Charger Faults" Section of This Manual	Go to Step #2
2	<ul style="list-style-type: none"> • Key Off • Check AC power supply • Is the rated AC supply voltage present? 		Go to Step #3	Check AC Supply Circuit Protection
3	<ul style="list-style-type: none"> • Key Off • Disconnect batteries • Unplug charger from AC supply • Check fuse located on rear side (lower RH corner) of charger • Is the fuse blown? 		Replace Fuse and Test Charger Operation	Go to Step #4
4	<ul style="list-style-type: none"> • Key Off • Inspect battery and charger cables for damage, corrosion, contamination or terminal problems • Do any of the above conditions exist? 		Repair or Replace Battery and/or Charger Cables	Go to Step #5
5	<ul style="list-style-type: none"> • Skip this step for sealed or AGM batteries • Key Off • Disconnect batteries • Check water level of all battery cells • Are the lead plates submerged? 		Go to Step #6	Add Distilled Water Until Lead Plates are Covered.
6	<ul style="list-style-type: none"> • Key Off • Load test all batteries (AGM or Lead-Acid) • -or- • Test specific gravity of each cell using a hydrometer or refractometer (Lead-Acid) • Do the batteries pass a load test or are all battery cells within 0.050 (50 points) specific gravity of each other? 		Replace Battery Charger	Replace Battery or Batteries

Terms:

AC = Alternating Current

AGM = Absorbed Glass Mat

Specific Gravity = Relative density of a substance compared to water (1.000 specific gravity)

TROUBLESHOOTING

Off Board Battery Charging ON

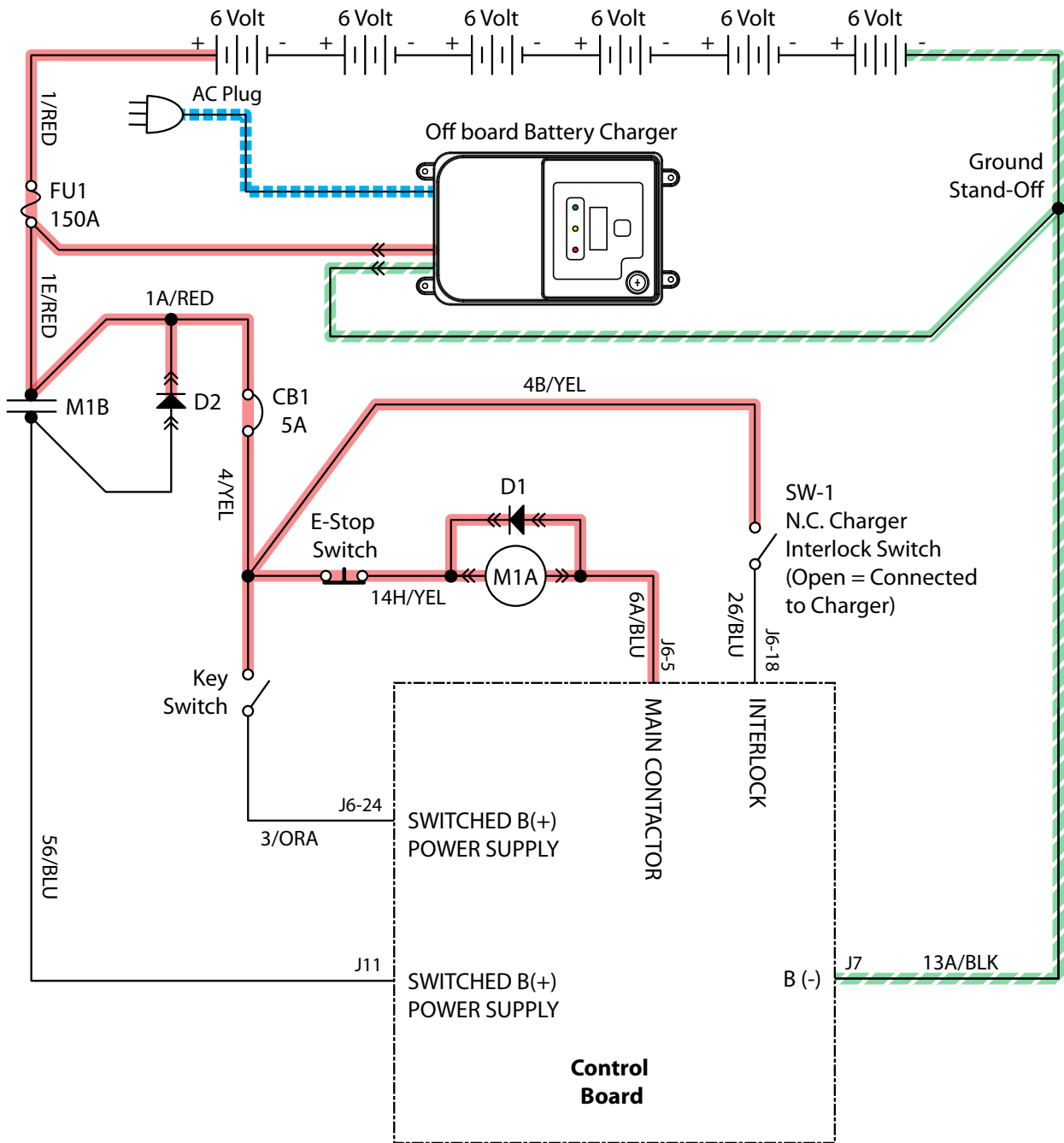

- Battery Positive +
- Battery Negative -
- AC Volts

NOTE: Battery charger interlock harness connects to main harness SW-1 interlock connection.

PMC021

Batteries Failed to Charge

STEP	ACTION	VALUE(S)	YES	NO
1	<ul style="list-style-type: none"> • Key Off • Check AC power supply • Is the rated AC supply voltage present? 		Go to Step #2	Check AC Supply Circuit Protection
2	<ul style="list-style-type: none"> • Key Off • Disconnect batteries • Unplug charger from AC supply • Check fuse located on front side of charger • Is the fuse blown? 		Replace Fuse and Test Charger Operation	Go to Step #4
3	<ul style="list-style-type: none"> • Key Off • Inspect battery and charger cables for damage, corrosion, contamination or terminal problems • Do any of the above conditions exist? 		Repair or Replace Battery and/or Charger Cables	Go to Step #4
4	<ul style="list-style-type: none"> • Skip this step for sealed or AGM batteries • Key Off • Disconnect batteries • Check water level of all battery cells • Are the lead plates submerged? 		Go to Step #5	Add Distilled Water Until Lead Plates are Covered.
5	<ul style="list-style-type: none"> • Key Off • Load test all batteries (AGM or Lead-Acid) • -or- • Test specific gravity of each cell using a hydrometer or refractometer ((Lead-Acid) • Do the batteries pass a load test or are all battery cells within 0.050 (50 points) specific gravity of each other? 		Replace Battery Charger	Replace Battery or Batteries

Terms:

AC = Alternating Current

AGM = Absorbed Glass Mat

Specific Gravity = Relative density of a substance compared to water (water = 1.000 specific gravity)

TROUBLESHOOTING

Parking Brake, Electromagnetic (Released)

Note: Key Switch ON

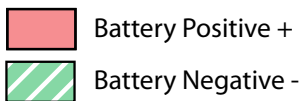
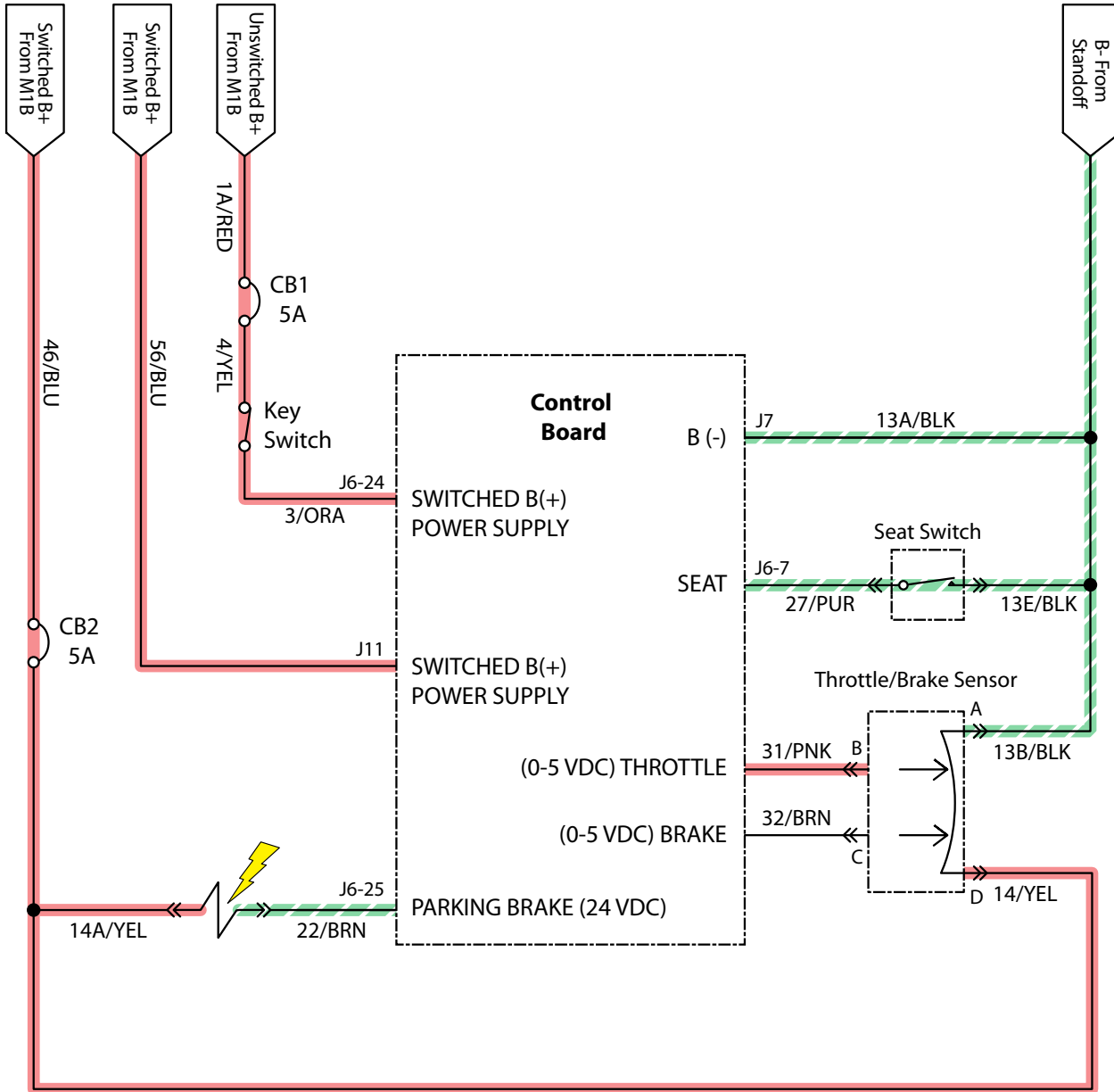

PMC015

Operational Matrix:

	Enabled	Disabled
Electro-magnetic Parking Brake	<ul style="list-style-type: none"> • Key OFF • E-Stop Switch Open (Down) • Battery Charger ON • Neutral (1-2 Second Delay) • Seat Switch Open • Load Current Fault 	<ul style="list-style-type: none"> • Key ON • E-Stop Switch Closed (Up) • Fwd/Rev Throttle Input • Seat Switch Closed

Parking Brake Failed to Release/Apply

STEP	ACTION	VALUE(S)	YES	NO
1	<ul style="list-style-type: none"> • Key On • Disable electromagnetic parking brake (release) • Is there an audible fault present? 		See "SpeedG-learn Faults" in the Troubleshooting section of this manual	Go to Step #2
2	<ul style="list-style-type: none"> • Key Off • See "Self-Test Mode" • Does the Self-Test display the parking brake output circuit as open or shorted? 		Correct Open or Short Circuit Condition	Go to Step #3
3	<ul style="list-style-type: none"> • Key Off • See "Propel Diagnostic Mode" • Are the forward and reverse directional switch inputs operating properly? • Is the throttle input operating properly? • Is the brake input operating properly? • Is the answer "Yes" to all of the above? 		Go to Step # 4	Correct Faulty Input Condition
4	<ul style="list-style-type: none"> • Key Off • See "Input Display Mode" • Is the seat switch input working properly? 		Go to Step #5	Correct Faulty Input Condition
5	<ul style="list-style-type: none"> • Key Off • Disconnect electromagnetic parking brake from main harness • Apply battery voltage to the electromagnetic parking brake using fuse-protected jumper leads • Does the parking brake "click" and release? 		Go to Step #6	Replace Parking Brake Assembly
6	<ul style="list-style-type: none"> • Reconnect electromagnetic parking brake to main harness • Key On • Disable electromagnetic parking brake (release) • Test voltage applied to the parking brake as shown on the electrical schematic • Are the electrical circuits operating as shown on the electrical schematic? 		Go Back to Step #1	Identify Voltage Drop Location and Repair or Replace Necessary Components

Terms:

LEDs = Light Emitting Diodes

TROUBLESHOOTING

Burnish Motor ON

Note: Key Switch ON

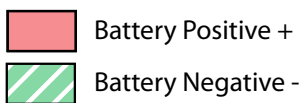
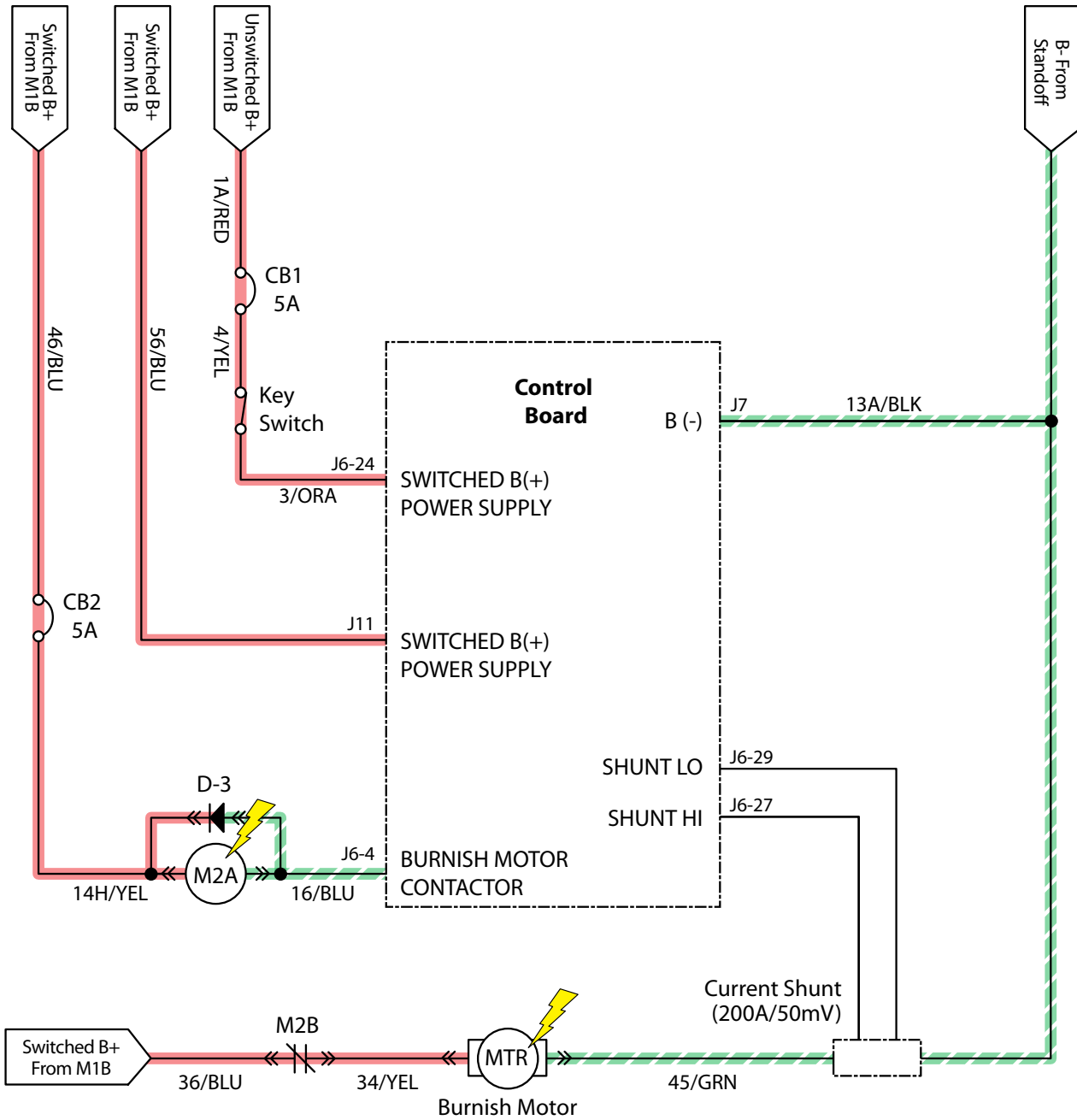

Operational Matrix:

	Enabled	Disabled
Burnish Motor ON	<ul style="list-style-type: none"> • 1-STEP Burnish ON • Fwd/Rev Throttle Input 	<ul style="list-style-type: none"> • 1-STEP Burnish OFF • Neutral - Ready State • Low Battery Voltage • Load Current Fault

PMC016

Burnish Motor Failed to Turn ON

STEP	ACTION	VALUE(S)	YES	NO
1	<ul style="list-style-type: none"> • Key On • Enable burnish motor • Is there an audible fault present? 		See "SpeedG-learn Faults" in the Troubleshooting section of this manual	Go to Step #2
2	<ul style="list-style-type: none"> • Key Off • See "Manual Mode" • Activate burnish motor in manual mode • Does the burnish motor turn ON? 		Go to Step #6	Go to Step #3
3	<ul style="list-style-type: none"> • Key Off • See "Self-Test Mode" • Does the Self-Test display the burnish motor contactor output circuit as open or shorted? 		Correct Open or Short Circuit Condition	Go to Step #4
4	<ul style="list-style-type: none"> • Key Off • See BURNISH MOTOR-CARBON BRUSHES in the SERVICE section of this manual and inspect the carbon brushes and clean the commutator using a commutator stone. • Does the burnish motor pass inspection? 	See BURNISH MOTOR - CARBON BRUSHES in the SERVICE section of this manual	Go to Step #5	Repair or Replace Burnish-Motor

TROUBLESHOOTING

Power-Up ON

Note: Key Switch ON

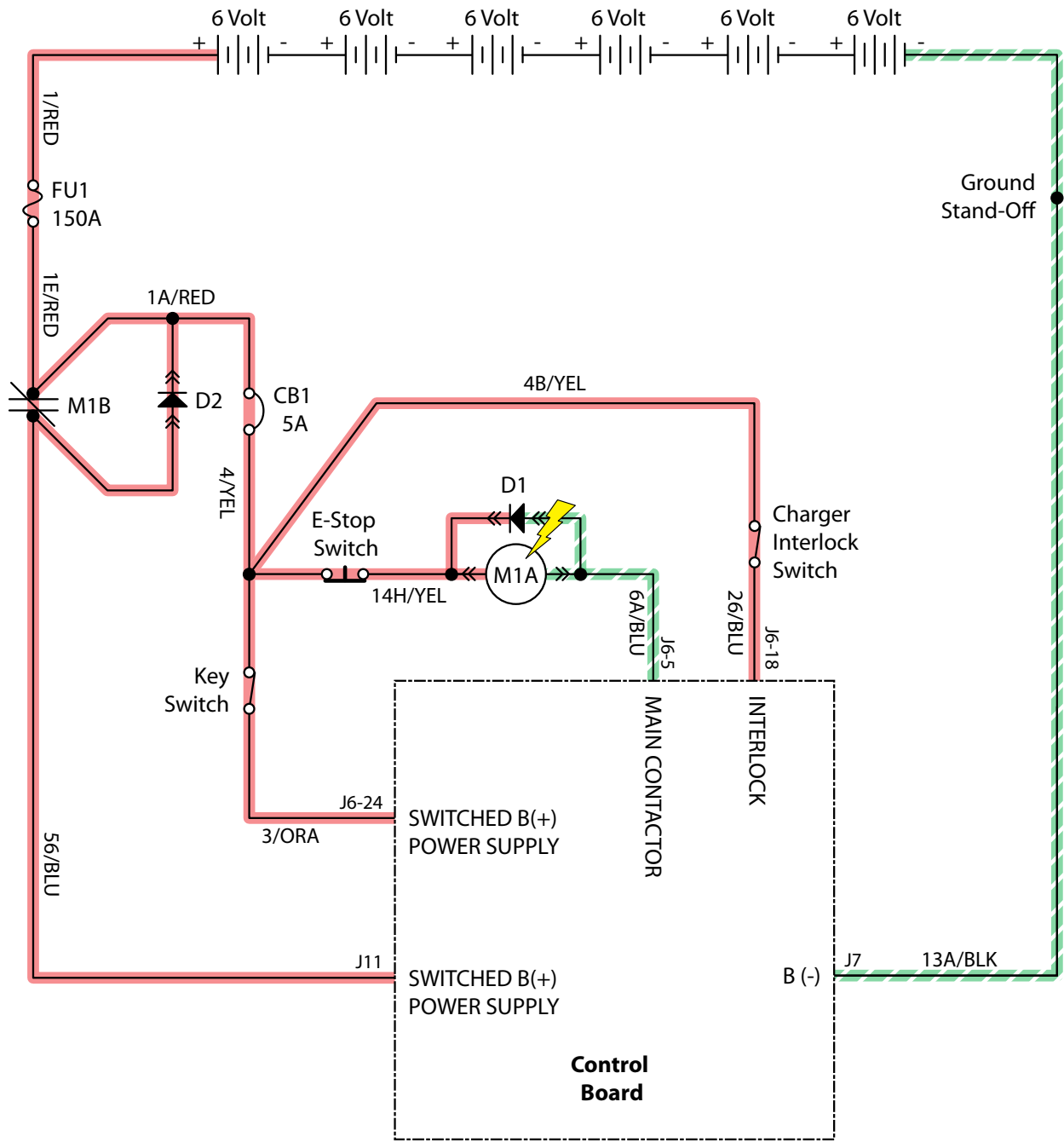

- Battery Positive +
- Battery Negative -

PMC017

Machine Failed to Power Up

STEP	ACTION	VALUE(S)	YES	NO
1	<ul style="list-style-type: none"> • Key in On Position • Test the total battery voltage using a voltmeter • Is the total battery voltage greater than 30 VDC? 		Go to Step #2	Recharge Batteries and Test Power-Up Circuit Operation
2	<ul style="list-style-type: none"> • Key Off • Test fuse #1 (150A) for continuity • Is fuse #1 blown or open? 		Replace Fuse and Test Power-Up Circuit Operation	Go to Step #3
3	<ul style="list-style-type: none"> • Key Off • Firmly press circuit breaker #1 to reset • Is circuit breaker #1 tripped? 		Reset and Test Power-Up Circuit Operation	Go to Step #4
4	<ul style="list-style-type: none"> • Key On • Test voltage applied to the power-up subsystem as shown on the electrical schematic • Are the electrical circuits operating as shown on the electrical schematic? 		Go Back to Step #1	Identify Voltage Drop Location and Repair or Replace Necessary Components

Terms:

VDC = DC Voltage

TROUBLESHOOTING

Propel Subsystem

Note: Key Switch ON

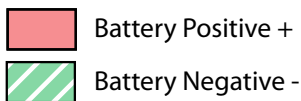
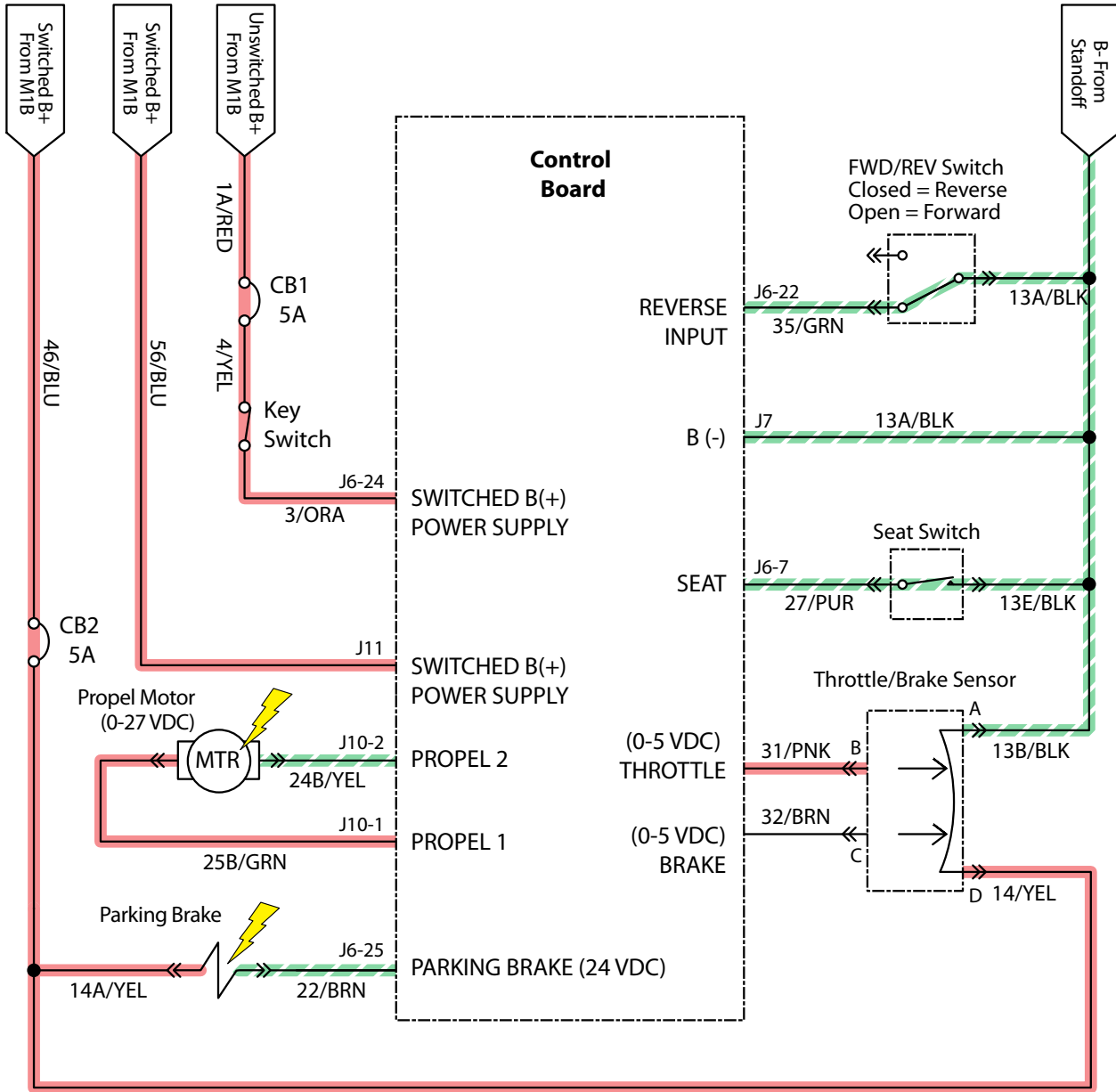

Operational Matrix:

	Enabled	Disabled
Propel	<ul style="list-style-type: none"> • Seat Switch Closed • Foot Throttle Command • Fwd/Rev Switch Input 	<ul style="list-style-type: none"> • Seat Switch Open • Neutral-Ready State • Brake Command • Controller Fault

PMC018

Machine Failed to Propel

STEP	ACTION	VALUE(S)	YES	NO
1	<ul style="list-style-type: none"> • Key On • Enable propel • Is there an audible fault present? 		See "SpeedG-learn Faults" in the Troubleshooting section of this manual	Go to Step #2
2	<ul style="list-style-type: none"> • Key Off • See "Propel Diagnostic Mode" • Is the variable throttle pedal input reflected by an LED change on the touch panel? • Is the brake pedal input selected by an LED change on the touch panel? • Is the directional switch input (fwd/rev) selected by an LED change on the touch panel? • Is the answer "Yes" to all of the above? 		Go to Step #3	Correct Faulty Input Condition
3	<ul style="list-style-type: none"> • Key Off • Place machine on jackstands so drive wheel is lifted off the floor • Enable forward propel • Test voltage applied to the propel subsystem as shown on the electrical schematic • Are the electrical circuits operating as shown on the electrical schematic? 		Go Back to Step #1	Identify Voltage Drop Location and Repair or Replace Necessary Components

Terms:

LED = Light Emitting Diode

VDC = Direct Current Voltage

TROUBLESHOOTING

Burnish Head Lift

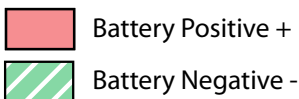
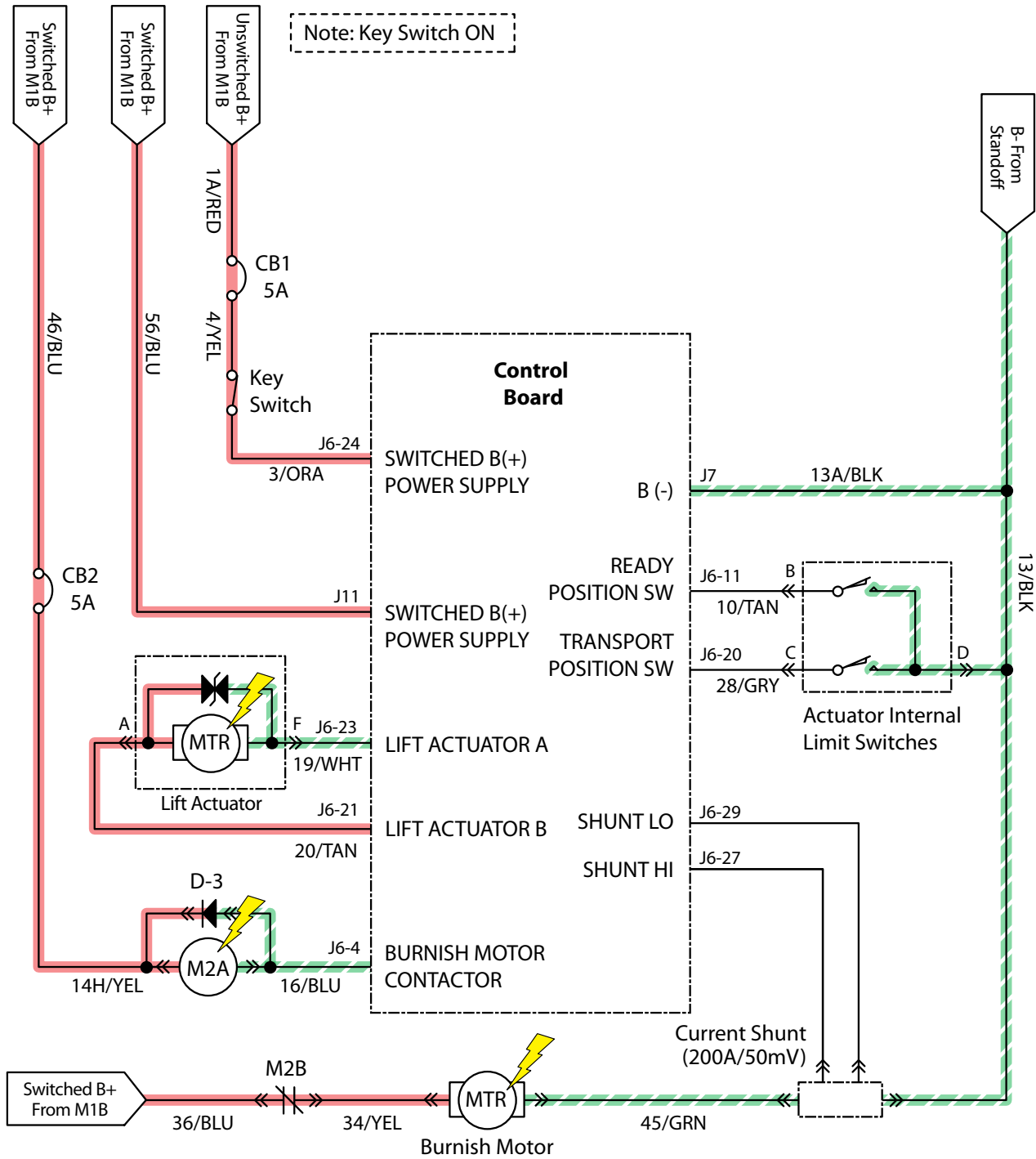

Operational Matrix:		
	Enabled	Disabled
Burnish Head Down (Completely - Pad ON)	<ul style="list-style-type: none"> 1-STEP Burnish ON Fwd/Rev Throttle Input 	<ul style="list-style-type: none"> 1-STEP Burnish OFF Neutral - Ready State Low Battery Voltage Load Current Fault

PMCO19

Burnish Head Failed to Raise/Lower

STEP	ACTION	VALUE(S)	YES	NO
1	<ul style="list-style-type: none"> • Key On • Enable burnish head down (completely-Pad ON) • Is there an audible fault present? 		See "SpeedGleam Faults" in the Troubleshooting section of this manual	Go to Step #2
2	<ul style="list-style-type: none"> • Key Off • See "Manual Mode" • Attempt to raise/lower the burnish head in manual mode • Does the burnish head raise/lower? 		Go to Step #5	Go to Step #3
3	<ul style="list-style-type: none"> • Key Off • See "Self-Test Mode" • Does the Self-Test display the lift actuator circuit as open or shorted? 		Correct Open or Short Circuit Condition	Go to Step #4
4	<ul style="list-style-type: none"> • Key Off • Test voltage applied to burnish head lift subsystem as shown on the electrical schematic • Are the electrical circuits operating as shown on the electrical schematic? 		Go Back to Step #1	Identify Voltage Drop Location and Repair or Replace Necessary Components

TROUBLESHOOTING

ADC (Active Dust Control) ON

NOTE: Key Switch ON

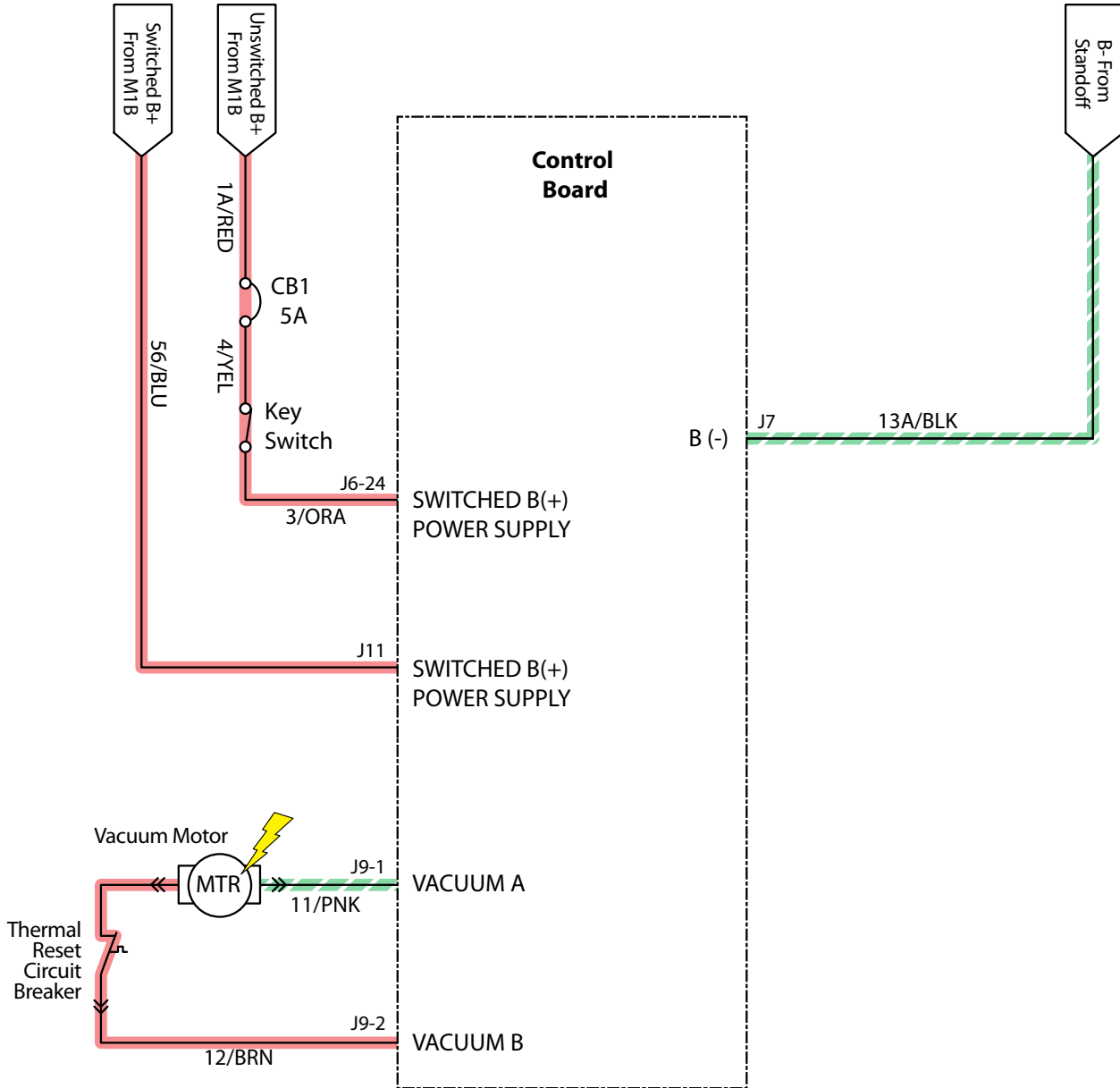

NOTE: Thermal reset circuit breaker located on bottom of canister vacuum. Push to reset.

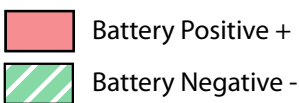

Operational Matrix:

	Enabled	Disabled
Vacuum Fan (Active Dust Control)	<ul style="list-style-type: none"> • 1-STEP Burnish ON • Vacuum ON 	<ul style="list-style-type: none"> • 1-STEP Burnish OFF • Vacuum OFF • Low Battery Voltage • Load Current Fault

PMC020

ADC (Active Dust Control) Failed to Turn ON

STEP	ACTION	VALUE(S)	YES	NO
1	<ul style="list-style-type: none"> • Key On • Enable ADC vacuum fan • Is there an audible fault present? • <i>NOTE: If the fan LED does not turn on/off when the fan button is pressed, then the machine is not configured for the ADC option. See CONFIGURATION MODE in the TROUBLESHOOTING section of this manual.</i> 		See "SpeedG-learn Faults" in the Troubleshooting section of this manual	Go to Step #2
2	<ul style="list-style-type: none"> • Key Off • See "Manual Mode" section of this manual • Activate ADC vacuum fan in manual mode • Does the vacuum fan turn On? 		Go to Step #5	Go to Step #3
3	<ul style="list-style-type: none"> • Key Off • See "Self-Test Mode" • Does the Self-Test display the vacuum fan output circuit as open or shorted? 		Correct Open or Short Circuit Condition	Go to Step #4
4	<ul style="list-style-type: none"> • Key Off • Reconnect vacuum fan motor to main wire harness • Key On • Enable ADC vacuum fan subsystem • Test voltage applied to the ADC vacuum fan subsystem as shown on the electrical schematic • Are the electrical circuits operating as shown on the electrical schematic? 		Go Back to Step #1	Identify Voltage Drop Location and Repair or Replace Necessary Components

Terms:

LED = Light Emitting Diode

ADC = Active Dust Control

SECTION 5

Contents	Page
SERVICE	
MAIN BURNISH HEAD.....	5-2
LIFT ACTUATOR.....	5-2
REMOVAL.....	5-2
INSTALLATION.....	5-3
BURNISH HEAD ASSEMBLY.....	5-4
REMOVAL.....	5-4
INSTALLATION.....	5-5
BURNISH MOTOR.....	5-6
REMOVAL.....	5-6
INSTALLATION.....	5-6
CARBON BRUSHES.....	5-6
WHEEL DRIVE ASSEMBLY.....	5-8
STEERING ASSEMBLY.....	5-8
REMOVAL.....	5-8
INSTALLATION.....	5-10
WHEEL DRIVE ASSEMBLY.....	5-10
REMOVAL.....	5-10
INSTALLATION.....	5-11
CARBON BRUSHES.....	5-12
DRIVE TIRE.....	5-13
REMOVAL.....	5-13
INSTALLATION.....	5-14
PARKING BRAKE, ELECTROMAGNETIC..	5-15
CHECKING AIR GAP.....	5-15
CHECKING ROTOR.....	5-16
TESTING BRAKE RESISTANCE.....	5-17
LOGIC BOARD.....	5-17
REMOVAL.....	5-17
INSTALLATION.....	5-18
THROTTLE/BRAKE SENSOR.....	5-19

SERVICE

MAIN BURNISH HEAD

REMOVING LIFT ACTUATOR

FOR SAFETY: Before leaving or servicing machine, stop on level surface, turn off machine and remove key.

1. Key Off and disconnect batteries.
2. Remove cotter and clevis pins from the tube-end of the lift actuator and carefully lower the burnish head to the floor. Set hardware aside.

NOTE: Use a long pry bar to lift the burnish head while removing the clevis pin. This will release the tension on the clevis pin, allowing for easy removal of the clevis pin.

NOTE: Alternative Method to Release Clevis Pin Tension: Support burnish head using a floor jack and turn actuator screw-drive using a pliers until clevis pin moves freely.

3. Remove cotter and clevis pins from the motor-end of the lift actuator and set hardware aside.



4. Remove electrical panel mounting hardware (5) and lower panel to allow access to electrical components.



5. Disconnect lift actuator from wire harness.

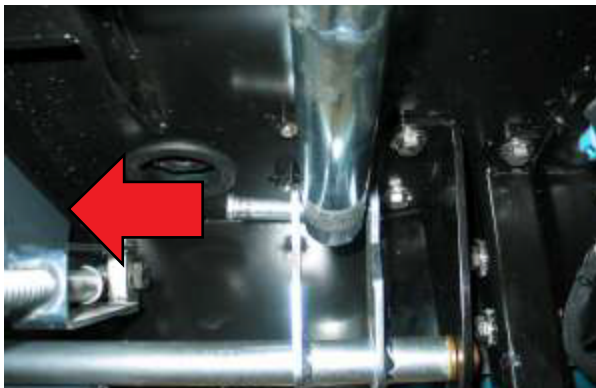

6. Push lift actuator connector through frame grommet and remove lift actuator.



INSTALLING LIFT ACTUATOR

FOR SAFETY: Before leaving or servicing machine, stop on level surface, turn off machine and remove key.

1. Key Off.
2. Connect lift actuator to wire harness.

NOTE: Apply electrical tape to secure the actuator connector to prevent damage while inserting the connector through the frame grommet.



3. **Turn key On and allow actuator to spin freely until it stops and then turn the key Off.**

4. Turn actuator tube by hand to set the exposed thread length to 3.75 in (9.5 cm) as shown below.



5. Install motor-end lift actuator clevis and cotter pins.



6. Place a jack beneath the center of the burnish head and carefully lift the head to align the actuator tube mounting holes with the lift mechanism mounting holes.



SERVICE

7. Insert the tube-end clevis and cotter pins.

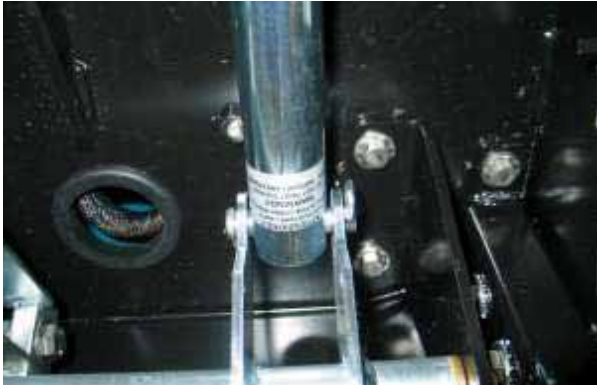

REMOVING BURNISH HEAD ASSEMBLY

FOR SAFETY: Before leaving or servicing machine, stop on level surface, turn off machine and remove key.

1. Enter *Manual Mode*. See *Manual Mode* in the *TROUBLESHOOTING* section of this manual.
2. Lower the burnish head and then turn the key off and disconnect the batteries.
3. Disconnect electrical cables (2) from motor.



4. Proceed to step 5 if removing burnish head to service the spring-loaded lift mechanism. Remove burnish head mounting bolts (4) and set aside. Remove burnish head.

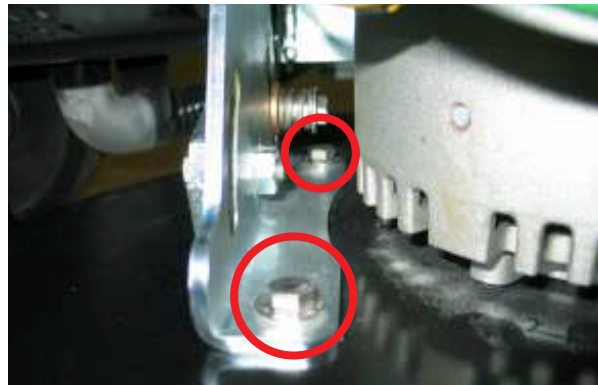
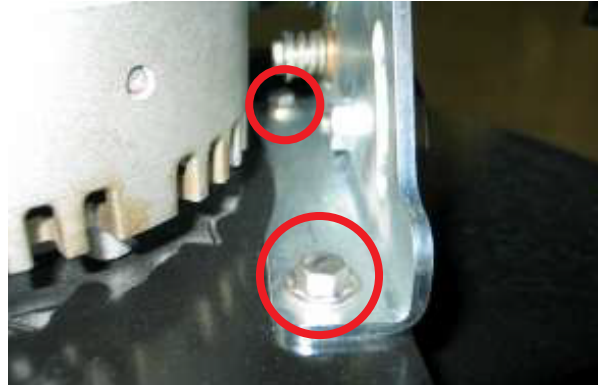

5. Remove spring link mounting hardware (2) and set aside.



6. Remove tensioner spring assemblies (2) and set aside.

NOTE: Note orientation of washers, spacers, and springs before removal.

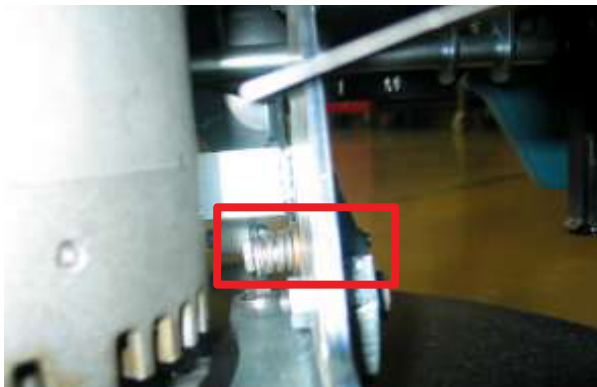

7. Carefully remove the burnish head pivot hardware (2) and set hardware aside.

NOTE: The linkage will release spring tension upward approximately 1-2 inches when the hardware is removed.



8. Remove burnish head.



INSTALLING BURNISH HEAD ASSEMBLY

FOR SAFETY: Before leaving or servicing machine, stop on level surface, turn off machine and remove key.

1. Installation is the reverse of removal. See INSTALLING LIFT ACTUATOR in the SERVICE section of this manual.

SERVICE

REMOVING BURNISH MOTOR

FOR SAFETY: Before leaving or servicing machine, stop on level surface, turn off machine, remove key and disconnect batteries.

1. See REMOVING BURNISH HEAD ASSEMBLY in the SERVICE section of this manual.
2. Remove burnish pad and use it as a protective pad beneath the motor when the burnish head is placed upside down.

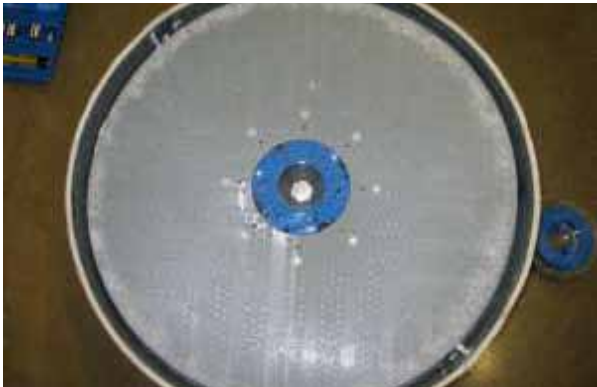

3. Remove burnish pad driver mounting hardware (1).



4. Insert a sacrificial M8 bolt into the motor shaft and drive the motor and head assembly off of the pad driver.



5. Remove motor mounting hardware (4) and motor from burnish head assembly.

INSTALLING BURNISH MOTOR

FOR SAFETY: Before leaving or servicing machine, stop on level surface, turn off machine, remove key and disconnect batteries.

1. Installation is the reverse of removal.

CARBON BRUSHES

1. See REMOVING BURNISH HEAD ASSEMBLY in the SERVICE section of this manual.
2. Remove upper motor cover mounting hardware and set cover aside.



3. Remove brush holder ring mounting hardware and brush mounting ring.



NOTE: Do not remove (4) brush holder phillips screws. The mounting nuts on the bottom side will fall into motor.

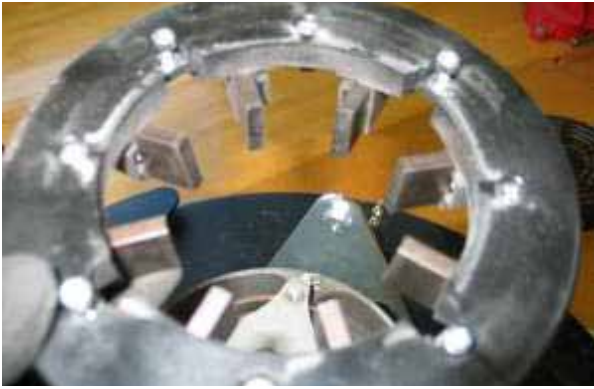

4. Remove brush tensioner springs (8).



5. Replace carbon brushes if they are less than 10mm (0.375 in).

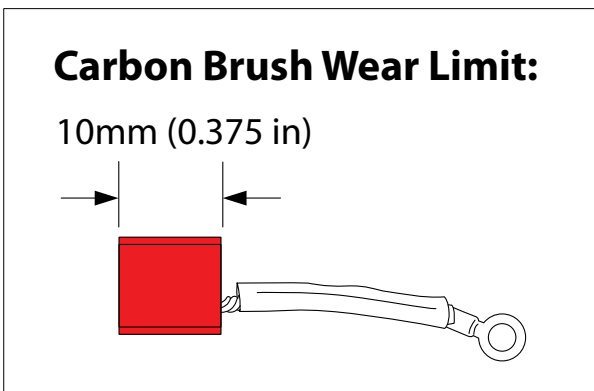

6. Clean the commutator using a stone and then use compressed air to clean any dust from inside the motor.

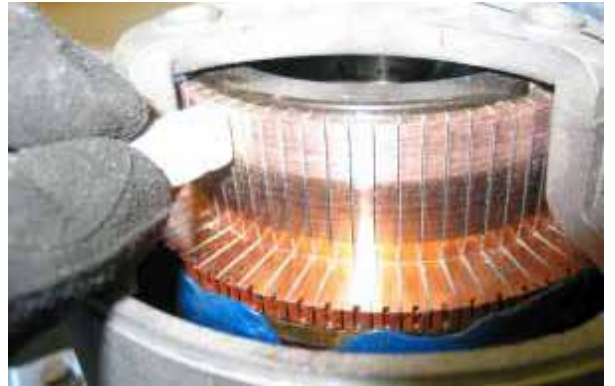

SERVICE

WHEEL DRIVE ASSEMBLY

REMOVING STEERING ASSEMBLY

FOR SAFETY: Before leaving or servicing machine, stop on level surface, turn off machine, remove key and disconnect batteries.

1. Loosen front access panel hardware (4) and remove front access panel and set aside.



2. Remove drive assembly lower mounting hardware (4) and set aside.



3. Remove steering wheel center cap and set aside.



4. Remove steering wheel mounting hardware (1).



5. Remove steering wheel from steering shaft using a hammer and chisel as shown below. Be sure to place the chisel on the metal insert of the steering wheel. Set steering wheel, shaft key, and boot aside.



6. Remove control console mounting hardware (4) and set aside.



7. Carefully pry upwards to remove the instrument panels from the control console.



8. Disconnect wire harness from instrument panels and set panels aside.

NOTE: Note positions before removing wires from panel components.



9. Remove control console and set aside.



10. Loosen steering joint set screws (2) and disconnect steering shaft from drive assembly shaft. Set key aside.



11. Loosen steering joint set screws (2) and disconnect steering shaft from drive-assembly steering shaft. Set key aside.



12. Loosen locking collar set screws (2) and remove locking collar from shaft. Set collar aside.

NOTE: The purpose of the locking collar is to prevent steering bearing damage if excessive downward force is applied to the steering wheel.



SERVICE

13. Jack machine slowly to remove steering assembly from machine.



14. Disconnect wire harness from wheel drive assembly.



INSTALLING STEERING ASSEMBLY

FOR SAFETY: Before leaving or servicing machine, stop on level surface, turn off machine, remove key and disconnect batteries.

1. Installation is the reverse of removal.

REMOVING WHEEL DRIVE ASSEMBLY

FOR SAFETY: Before leaving or servicing machine, stop on level surface, turn off machine, remove key and disconnect batteries.

1. Loosen front access panel hardware (4) and remove front access panel and set aside.



2. Disconnect wheel drive assembly from wire harness and set cover and mounting hardware aside.



3. Remove mounting hardware (4) and set aside.



4. Carefully jack up machine to remove drive assembly.



INSTALLING WHEEL DRIVE ASSEMBLY

FOR SAFETY: Before leaving or servicing machine, stop on level surface, turn off machine, remove key and disconnect batteries.

1. Installation is the reverse of removal.

SERVICE

CARBON BRUSHES

FOR SAFETY: Before leaving or servicing machine, stop on level surface, turn off machine, remove key and disconnect batteries.

1. Remove (4) commutator brushes.



2. Replace carbon brushes if they are less than 10mm (0.375 in).

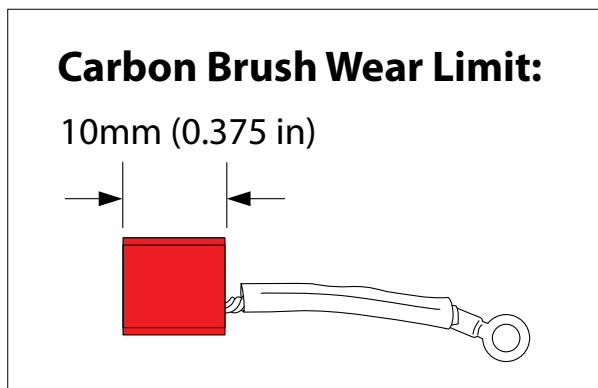

3. Remove electrical connection box from drive assembly.



4. Replace carbon brushes if they are less than 10mm (0.375 in).

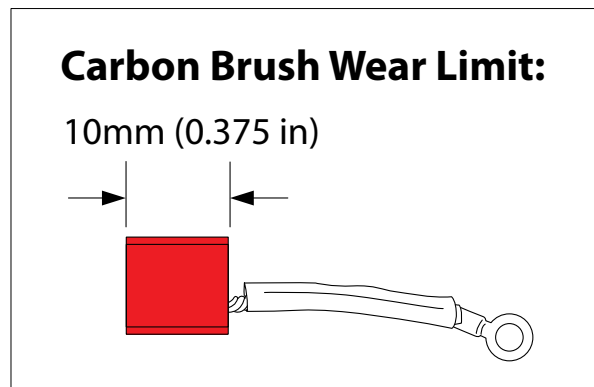

REMOVING DRIVE TIRE

FOR SAFETY: Before leaving or servicing machine, stop on level surface, turn off machine, remove key and disconnect batteries.

1. See REMOVING WHEEL DRIVE ASSEMBLY in the SERVICE section of this manual and remove the wheel drive assembly.
2. Remove rubber dust cover and set aside.



3. Draw a line on the brake and drive assemblies to reference orientation during reassembly.



4. Remove brake assembly mounting hardware (3) and set aside.



5. Remove brake and rotor and set aside.



6. Remove snap ring and set aside.



SERVICE

7. Remove shaft spline and key.



8. Remove wheel assembly end plate using a two-jaw puller.



9. Remove wheel mounting hardware (8).



10. Lift to remove tire from wheel drive assembly and set aside.



INSTALLING DRIVE TIRE

FOR SAFETY: Before leaving or servicing machine, stop on level surface, turn off machine, remove key and disconnect batteries.

1. Installation is the reverse of removal.

PARKING BRAKE, ELECTROMAGNETIC

CHECKING AIR GAP

FOR SAFETY: Before leaving or servicing machine, stop on level surface, turn off machine and remove key.

FOR SAFETY: When servicing machine, disconnect battery connection before working on machine.

1. Key Off and batteries disconnected.
2. Remove rubber dust cover and set aside.



3. Check the brake air gap next to each mounting pedestal using a feeler gauge. The air gap must be between 0.008 in (0.20mm) and 0.012 in (0.31mm).



4. If an air gap adjustment is required, then remove the electrical box/slip-ring brush holder to access the upper brake pedestal adjustment.



5. Adjust each pedestal to set the air gap separately:
 - Loosen screw
 - Turn pedestal using an 8mm open-end wrench
 - Tighten screw
 - Check air gap
 - Repeat as needed until 0.008 in(0.20mm) - 0.012 in(0.31mm) air gap is achieved next to each pedestal.



SERVICE

CHECKING ROTOR

FOR SAFETY: Before leaving or servicing machine, stop on level surface, turn off machine, remove key and disconnect batteries.

1. Remove rubber dust cover and set aside.



2. Draw a line on the brake and drive assemblies to reference orientation during reassembly.



3. Remove brake assembly mounting hardware (3) and set aside.



4. Remove brake and rotor.



5. Measure the thickness of the brake rotor using a vernier caliper. Replace the rotor if it is less than 4 mm (0.18 in) thickness.

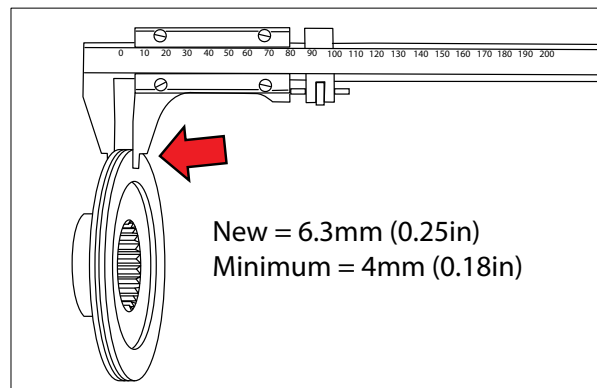

TESTING BRAKE RESISTANCE

FOR SAFETY: Before leaving or servicing machine, stop on level surface, turn off machine, remove key and disconnect batteries.

1. Disconnect brake assembly from wire harness.



2. Backprobe the brake connector using an Ohmmeter.



3. The brake resistance value should read 26-30 Ω .



LOGIC BOARD

REMOVING LOGIC BOARD

FOR SAFETY: When servicing machine, disconnect battery connections before working on machine.

1. Key Off and batteries disconnected.
2. Remove electrical access panel mounting hardware (5) and lower access panel.



3. Attach a static wrist strap to the battery (-) stand-off or battery (-) terminal to prevent ESD damage to the logic board.



SERVICE

4. Remove logic board cover mounting hardware (7) and cover and set aside.



5. Disconnect logic board from wire harness.



6. Remove logic board assembly mounting hardware (4).



7. Remove logic board assembly.



INSTALLING LOGIC BOARD

FOR SAFETY: When servicing machine, disconnect battery connections before working on machine.

1. Installation is reverse of removal.

NOTE: Always use two wrenches when securing the power supply terminals or damage to the circuit board will occur. Also, make sure the power supply terminals are secured on the new board before installation. The torque specification 52 in-lbs (6 Nm).

2. See CONFIGURATION MODE in the TROUBLESHOOTING section of this manual to configure the software to match the actual machine configuration (i.e. active dust control, 24 in/27 in head, etc.).

TESTING THROTTLE/BRAKE SENSOR

FOR SAFETY: Before leaving or servicing machine, stop on level surface.

FOR SAFETY: When servicing machine, jack machine up at designated locations only. Block machine up with jack stands.

FOR SAFETY: When servicing machine, avoid moving parts. Do not wear loose jackets, shirts, or sleeves when working on machine .

1. Jack machine up so front drive wheel is not touching the floor. Block machine up with jack stands.

NOTE: See steering column removal in the **STEERING ASSEMBLY REMOVAL** procedure in the **SERVICE** section of this manual.

2. The throttle and brake hall effect sensor is a component of the pedal subassembly.

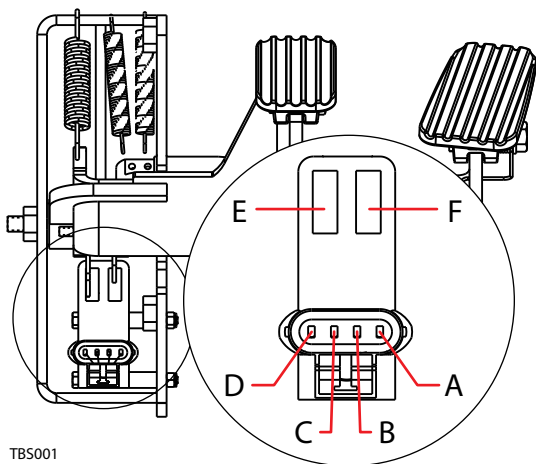

TBS001

3. Key On. Backprobe the power supply to the throttle/brake sensor terminals A and D using a voltmeter as shown below. The voltmeter should display battery voltage.

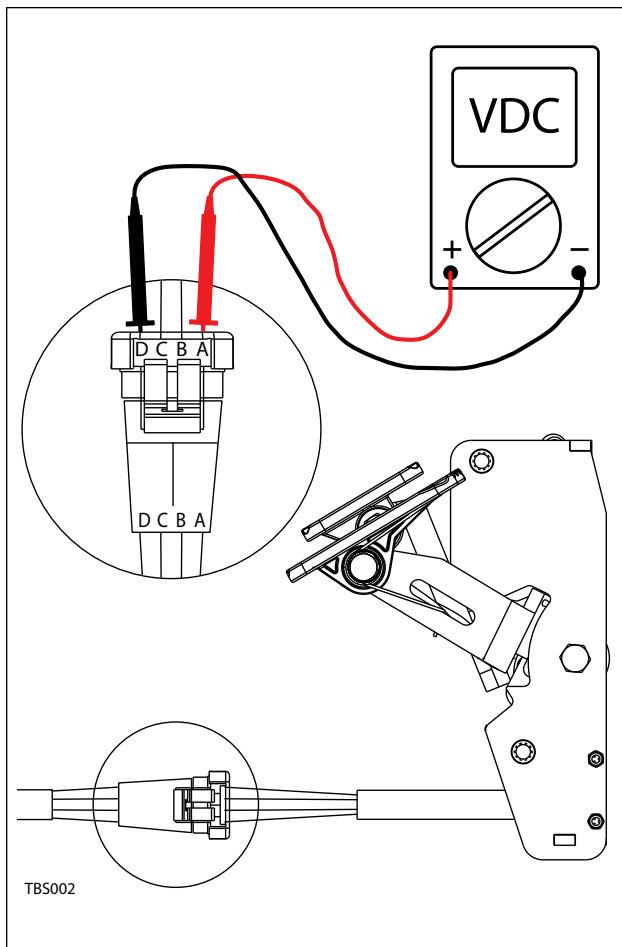

PIN/CAVITY	NOTES	COLOR
A	POWER (BATTERY +)	RED
B	FORWARD OUTPUT (0-5Vdc)	YELLOW
C	BRAKE (0-5Vdc)	BLUE
D	GROUND (BATTERY -)	BLACK
E	GATE A	N/A
F	GATE B	N/A

SERVICE

4. Key On. Backprobe the throttle sensor output terminals B and D using a voltmeter as shown below. The voltmeter should display 0-5 volts proportional to 0-100% propel pedal movement.

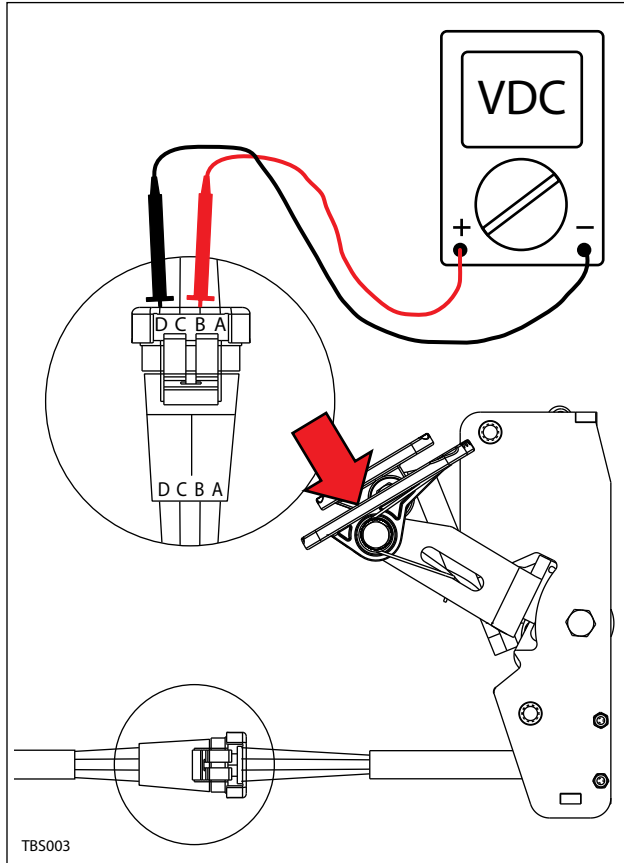

5. See PROPEL DIAGNOSTIC MODE in the TROUBLE-SHOOTING section of this manual. There should be a corresponding change in LEDs on the display when depressing the throttle pedal.

6. Key On. Backprobe the brake sensor output terminals C and D using a voltmeter as shown below. The voltmeter should display 5 volts when the brake pedal is activated

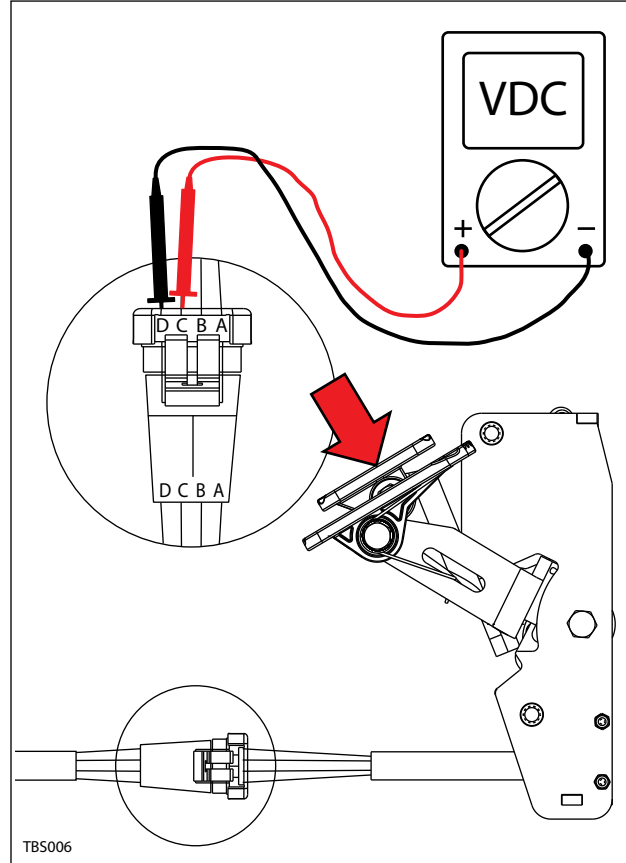

7. See PROPEL DIAGNOSTIC MODE in the TROUBLE-SHOOTING section. The change in voltage in Step 6 should correspond to a LED change on the instrument panel.



TENNANT COMPANY
 Technical Publications #15
 701 North Liliac Drive
 P.O. Box 1452
 Minneapolis, MN 55440-9947

POSTAGE WILL BE PAID BY ADDRESSEE

BUSINESS REPLY MAIL
 FIRST CLASS MAIL PERMIT NO. 94 MINNEAPOLIS, MN

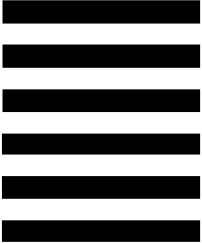

NO POSTAGE
 NECESSARY
 IF MAILED
 IN THE
 UNITED STATES



Fold along dotted lines
 Tape here



We Need Your Help...

As part of Tennant's Zero Defects Program, we want to know about errors you have found or suggestions you may have regarding our machine manuals. If you find an error or have a suggestion, please complete this postage-paid form and mail it to us. Thank you for helping us make zero defects a way of life at Tennant.

Manual No. _____ Rev. No. _____ Publish Date _____ Page _____

Machine _____ Report Error Suggestion

Name _____ Date _____

Customer Number _____

Company _____

Address _____

City/State/Zip Code _____



TENNANT COMPANY
 Technical Publications #15
 701 North Liliac Drive
 P.O. Box 1452
 Minneapolis, MN 55440-9947

POSTAGE WILL BE PAID BY ADDRESSEE

BUSINESS REPLY MAIL
 FIRST CLASS MAIL PERMIT NO. 94 MINNEAPOLIS, MN

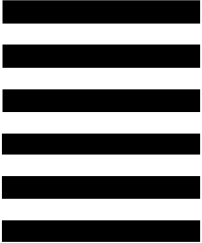

NO POSTAGE
 NECESSARY
 IF MAILED
 IN THE
 UNITED STATES



Fold along dotted lines
 Tape here

