

SCOTT-SPORTS.COM



SCOTT SPORTS SA / 17 RTE DU CROCHET / 1762 GIVISIEZ / SWITZERLAND
© 2008 SCOTT SPORTS SA, ALL RIGHTS RESERVED

S

SPARK

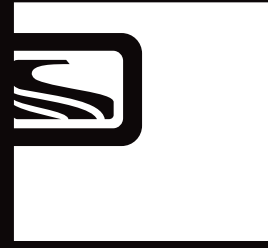

SCOTT
2008

BIKE OWNERS MANUAL
OWNERS MANUAL / BEDIENUNGSANLEITUNG / MANUEL D'UTILISATION

CONFORME AUX EXIGENCES DE SECURITE
NF R30-020



The Spark should be adjusted exactly to the current rider for reaching maximum safety and fun while riding.

All adjustments should be done at the local Scott dealer or following to this manual.

CONTENT

> Spark Concept	p. 2
> Geometry/Technical Data Spark	p. 3
> Shock Technology	p. 4
> Nude TC Shock and Tracloc Remote Control Lever Technology	p. 6
> Basic Set-Up of the TRAC-LOC Remote Control	p. 7
> Set-Up of TRAC-LOC Remote Control MK1	p. 8
> Set-Up of TRAC-LOC Remote Control MK2	p. 10
> Recommended Tools for the Shock Set-Up	p. 12
> Set-Up Spark with Scott Nude TC Shock	p. 12
> Set-up of Rebound Nude TC Shock	p. 13
> Set-up of other Shock Models	p. 14
> Scott Sealed Cable Routing	p. 15
> Adjustment of Seatpost-Height	p. 16
> Replaceable Drop Out	p. 19
> Front Fork Set-Up/ Change of Front Fork	p. 19
> Pivot Maintenance	p. 19
> Warranty	p. 20



SPARK CONCEPT

Spark is the result of 2 years of research and development for the lightest mountain bike frame set available on the market, hitting the scale at below 1800 grams (4 pounds) including the frame, Scott Nude TC shock and TRAC-LOC remote control.

Scott's focus was not only on lightweight but also on a durable frame with an innovative suspension technology in combination with an optimized kinematics of the rear swingarm.

The combination of an optimized kinematics with an extraordinary suspension technology closes the gap between superlight hardtail bikes (e.g. Scott Scale) and the new generation of marathon bikes (e.g. Scott Genius MC).

Spark was designed for riders looking for a dual suspended race and marathon bike offering a maximum rear wheel travel of 110mm.

Scott does not see frame, rear shock and kinematics as single components which are assembled together on a bike, but as a concept with all these components working together and offering an outrageous function by matching perfectly.

KINEMATICS

The Spark Concept is based on a new designed multi-pivot technology.

In combination with the linear shock characteristics the chain tension will be reduced and doing so the pedaling will not influence function or movement of the rear swingarm.

The Scott system, named TC (Traction Control) will allow you to reduce by remote control the rear wheel travel from 110mm to 70mm including a more progressive spring rate but still offering a supple break away.

No power will be lost and an optimum power transfer is guaranteed as the swingarm, in contrary to locked or automatic-locking systems, can follow the trail surface and will offer perfect traction and higher speed while standing on the pedals.

GEOMETRY/ TECHNICAL DATA SPARK

Size	Headangle	HT Length	TT Horiz.	Seatangle	Top ST	CST Length	BB OS
S	69.5°	110	555	73.5°	400	422	- 10
M	69.8°	120	585	73.5°	450	422	- 10
L	70°	140	610	73.5°	490	422	- 10
XL	70°	160	640	73.5°	540	422	- 10

Travel	110/70/0mm
Suspension Ratio	2.97
Piston stroke	37mm
Shock (Eye to Eye)	165mm
Hardware Mainframe	22,2mm x 6mm
Hardware Swingarm	22.2mm x 6mm
Seatpost diameter	34,9mm, some models with integrated seatpost
Headset	1 1/8" semi integr. with 44.0mm cups
Fork travel	100mm
Fork length	471mm
BB housing	73mm
Front derailleur	Downswing 34.9mm Downpull
Bearings	2 x 61900 (22x10xT6) 6 x 63800 (19x10xT7)



SHOCK-TECHNOLOGY

The heart of the TC-System is the new developed and innovative Scott Nude TC Shock made by DT Swiss, offering three functions which make this system possible.

By using the TRAC-LOC remote lever you can chose following functions:

1. ALL TRAVEL MODE: full travel of 110mm
2. TRACTION MODE: by reducing the internal chamber volume inside the shock the travel of the shock will be reduced to around 60% (approx. 70mm) the characteristic of the air spring gets harder. This results in climbing without "bobbing" and offers still optimum traction of the rear wheel.

3. LOCK OUT MODE: the shock is locked; climbing on asphalt roads is now possible without any power loss. Simultaneous a blow-off-system prevents the shock being damaged in case the rider did not open the system while crossing obstacles.

You will find the following positions on the remote lever: **[1]**

Please note that you can only assemble the TRAC-LOC remote lever in "left side upward position" on the handlebar.

You have 3 positions of the TRAC-LOC remote lever.

- most forward position: LOCK OUT
- middle position: TRACTION MOEDE
- most backward position: ALL TRAVEL MODE

Change the modes by pushing the lever with your fingers frontward and release them by tapping the release button (one mode per push/release)

1

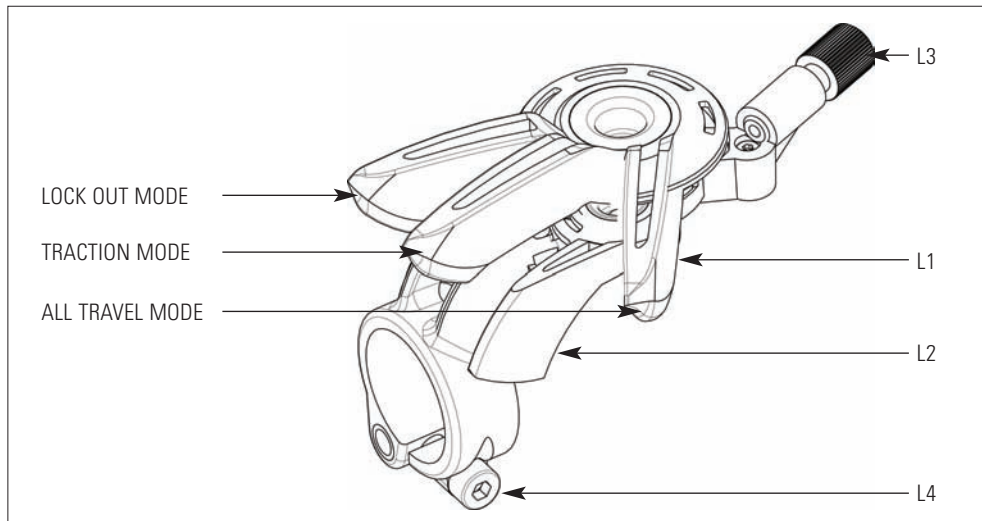

remote lever

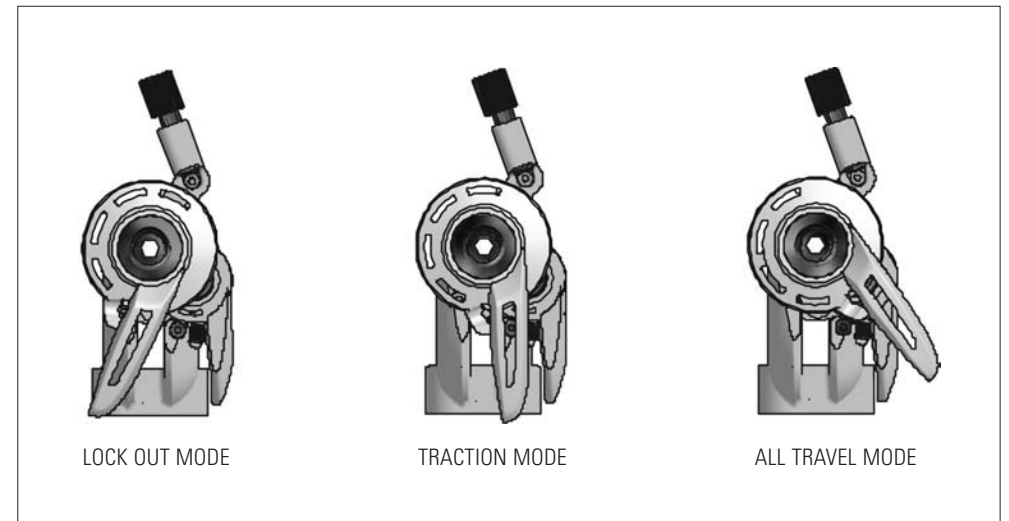

NUDE TC SHOCK AND TRAC-LOC REMOTE CONTROL LEVER

In the drawing of the shock and remote lever, shown below, you will see the parts indicated with numbers which will be used in the manual for the adjustment and set-up.

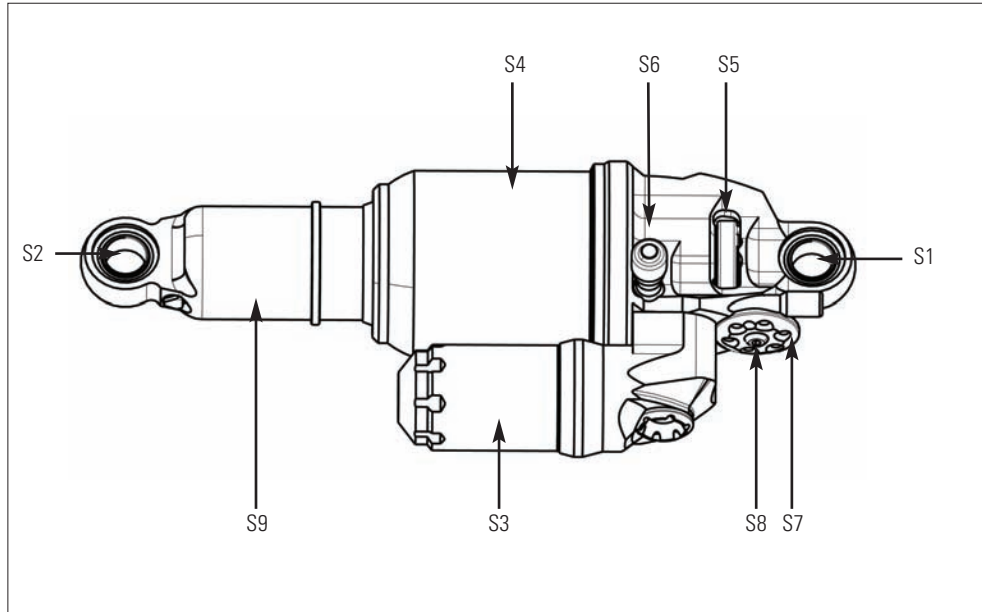

S1	Front eyelet/ Shock Bolt	L1	Remote Lever
S2	Rear eyelet/ Shock Bolt	L2	Release Lever
S3	Piggy-Back	L3	Tension Screw
S4	Shock Housing	L4	Allen Screw
S5	Rebound-Screw		
S6	Positive Chamber Valve		
S7	Lock Out Barrel		
S8	Cable fixing Screw		
S9	Shock Piston		

BASIC SET-UP OF THE TRAC-LOC REMOTE CONTROL OF NUDE TC SHOCK

To ensure perfect function of the Nude TC shock it is very important to follow the steps shown below exactly

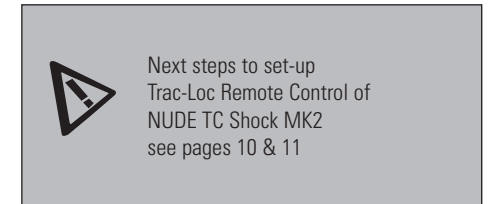
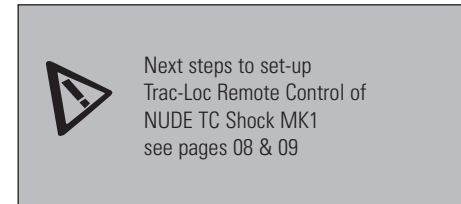
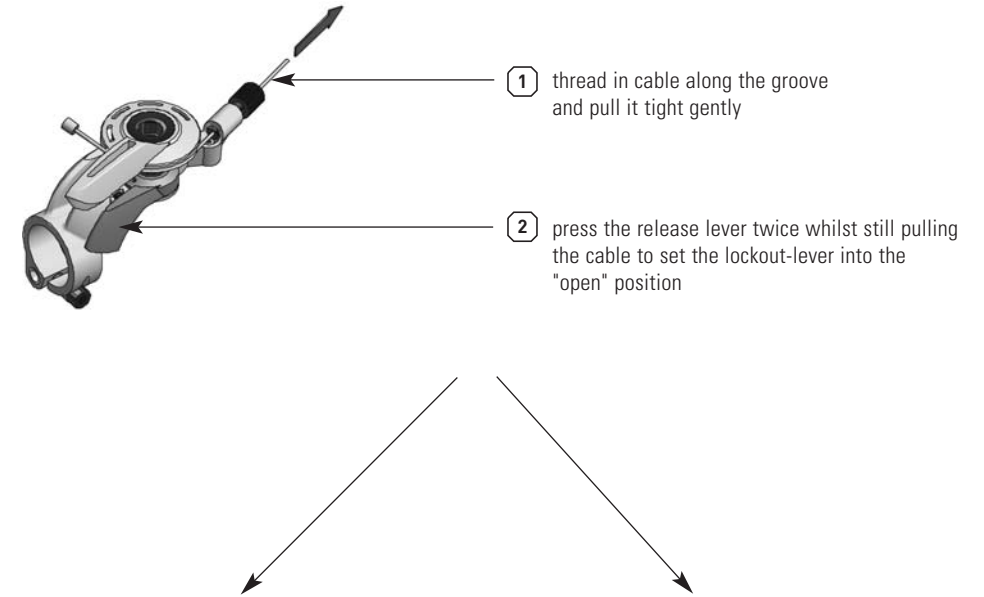

SET-UP OF THE TRAC-LOC
REMOTE CONTROL
OF NUDE TC SHOCK MK1

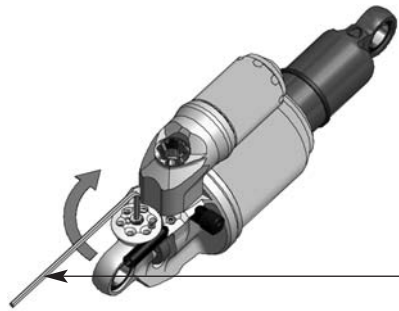

This is only for
NUDE TC Shock MK1

3 turn clockwise up to the stop by using
a 2mm Allen key

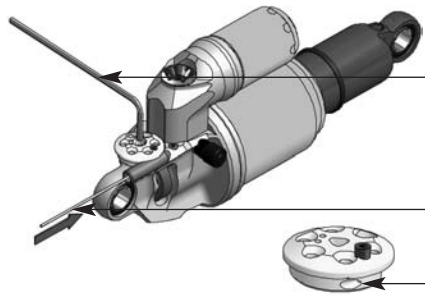

4 keep the Allen key kept in its end
position and ...

thread in the cable ...

into this bore.

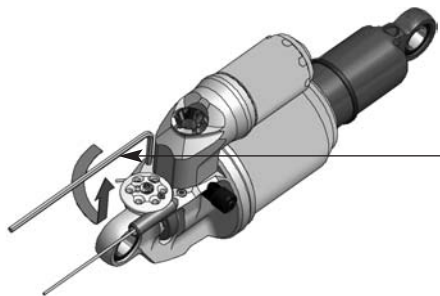

5 Release the Allen key gently counterclockwise
and pull it off

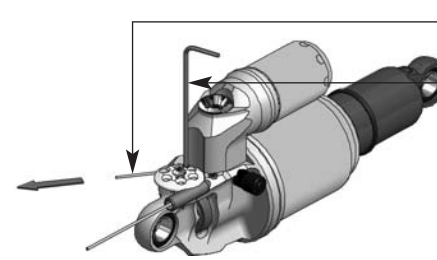

6 Pull the cable tight ...

then tighten the headless 3mm-screw by
using a 1,5mm-Allen key. (max. 1.3 Nm)

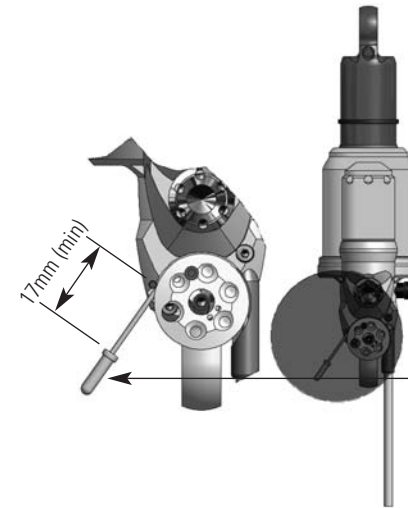

7 Put on the end cap and make sure to have
at least 17mm of free cable length.

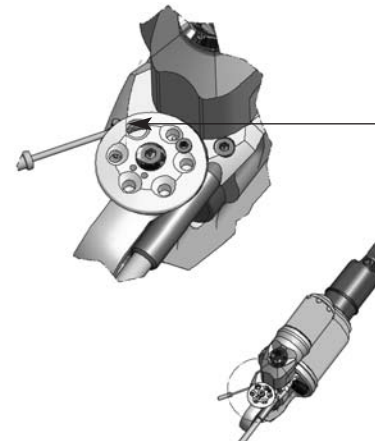

in Traction-Mode the 4mm bore aligns
with the edge on the shock body



**SET-UP OF THE TRAC-LOC
REMOTE CONTROL
OF NUDE TC SHOCK MK2**

 This is only for
NUDE TC Shock MK2

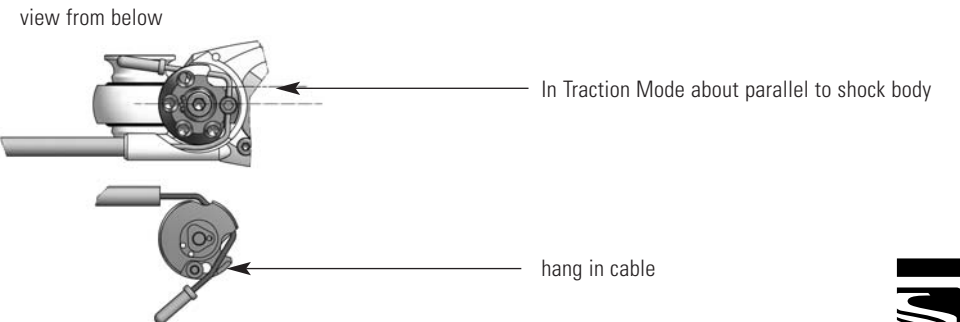
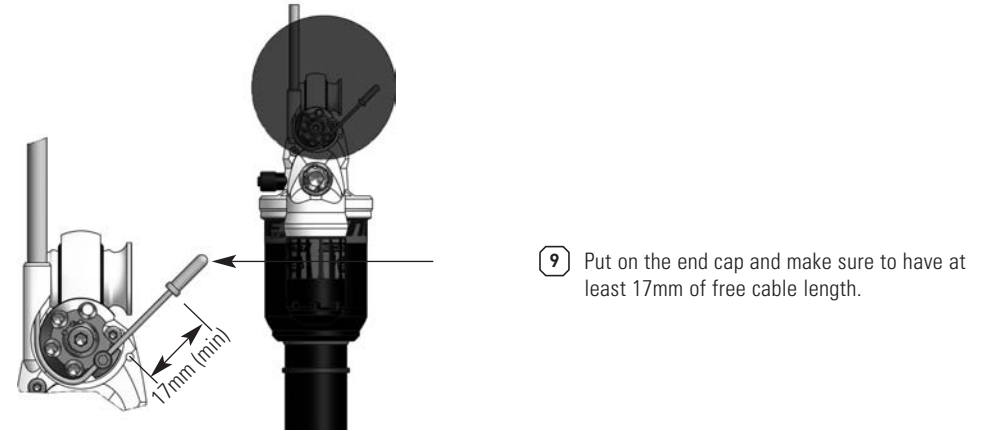
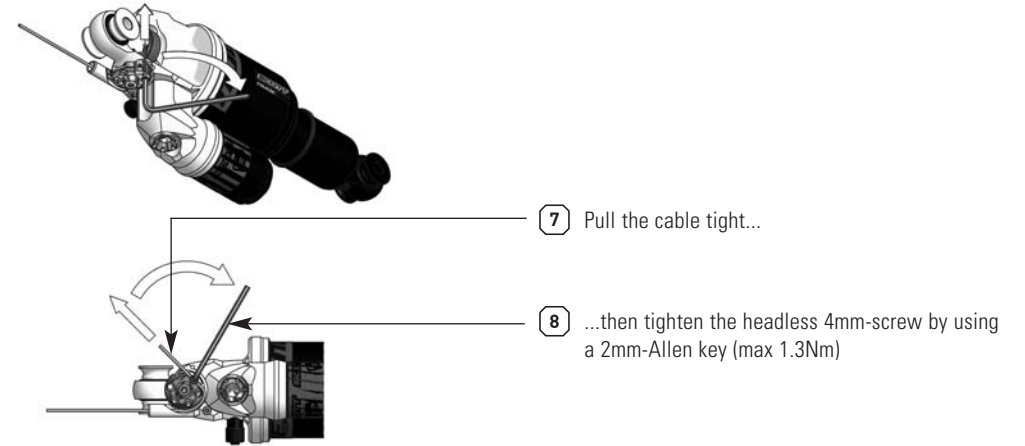
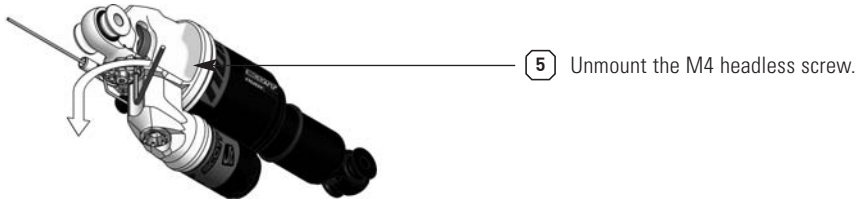
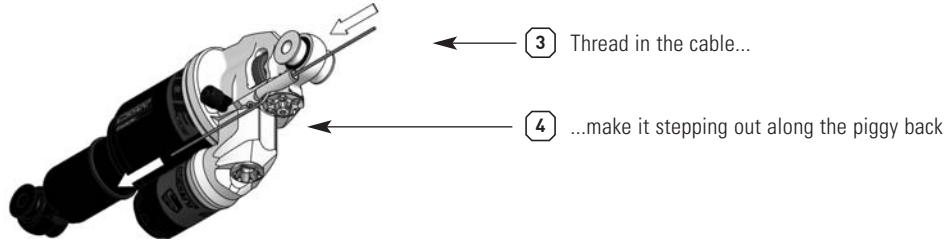

RECOMMENDED TOOLS FOR THE SHOCK SET-UP

For the set-up of the shock we recommend to use a shock pump with a scale up to 20 bars/300 psi with a special air valve connector preventing from air getting away while removing the pump from the shock valve, this will result in an exact air pressure.

Please note that air will flow into the hose and indicator when counterchecking the air pressure, so you have to set up again the recommended pressure after this action.

SET-UP SPARK WITH NUDE TC SHOCK

The Set-Up of the Scott Nude TC Shock can be easy done within a few minutes.



Important: For all adjustments of the air spring the remote lever has to be in position "all travel".

To adjust the air pressure of the positive chamber of the Scott Nude TC Shock please refer to the following instruction:

1. Remove the valve cap of the valve (S6) located on the shock housing (S4).
2. Mount the shock pump with its adaptor on the valve
3. Pls take into account that it takes some air pressure from inside the shock to drive the indicator on the pump. Make sure to balance at least this air loss when you make a check of the air pressure of the shock. Pls also note that the indicators of shock pumps have a tolerance of max. 10%
4. Pump the recommended pressure into the shock. On the inner side of the left seatstays you will find a table showing the recommended air pressure of the positive chamber according to the rider's weight.
5. When you reached the needed pressure remove the pump and put the valve cap on the valve

rider weight	kg	45	50	55	60	65	70	75	80	85	90	95
	lb	99	110	121	132	143	154	165	176	187	198	209
+ air setting	bar	5,0	5,8	6,6	7,4	8,2	9,0	9,8	10,6	11,4	12,2	13,0
	psi	73	84	96	107	119	131	142	154	165	177	189

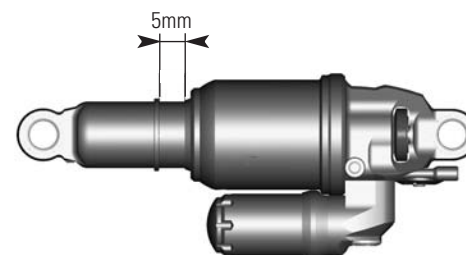

The SAG should be 5mm on the shock piston.

To check the adjustment, please follow as shown below:

1. Sit on the bike, put your feet on the pedal
2. Put your feet back on the ground and stand over the bike without bouncing the bike during this action
3. Check if the o-ring on the shock piston has a distance of 5mm to the main dust wiper/seal between shock housing and piston.
 - if the distance between the o-ring and the main dust wiper/seal is less than 5mm, the air pressure of the air chamber is too high and should be carefully reduced by using the bleed knob of the shock pump until the distance is 5mm.
 - if the distance between the main dust wiper/seal is bigger than 5mm, the air pressure of the air chamber is too low and should be increased by using the shock pump until the distance is 5mm.

SET-UP OF REBOUND NUDE TC SHOCK

"Rebound" describes the speed the shock comes back to its original length after absorbing an obstacle.

By using the red rebound screw (S6) you can adjust the rebound step by step.

Please refer to the following instruction:

Ride your bike off a pavement (remain in the saddle) and check how many times it bounces.

- if it bounces 1-2 times, the set up is good.
- If it bounces more than 3 times the rebound is too fast. Turn the screw 1-2 "clicks" clockwise
- If it does not bounce the rebound is too slow. Turn the screw 1-2 "clicks" counter clockwise.



SET-UP OF OTHER SHOCK MODELS:

Scott strongly recommends using only the Scott Nude TC Shock with the Spark bike, as we designed both parts for a perfect matching combination with a linear suspension rate.

If you want to use a different rear shock model than the one originally on the bike, please make sure that the shock will not in any position hit the frame and cause a damage to the frame.

Please follow the instruction below:

Please make sure that the rear shock or its accessory parts do not touch the frame when mounting or suspending.

For doing so release the air/remove the coil, install the shock and compress the shock completely.

If the shock touches the frame while doing so, do not use this shock in order to avoid damage to frame, swingarm or shock.

In case you want even more detailed figures of air pressure or tuning hints, you can download a program under www.scott-sports.com as a MS Excel file.



Important: Note that you have to mount the Scott Nude TC Shock always as shown underneath.

Mounting the rear shock in a different position can cause severe damages to the frame, the linkage levers and the rear shock.

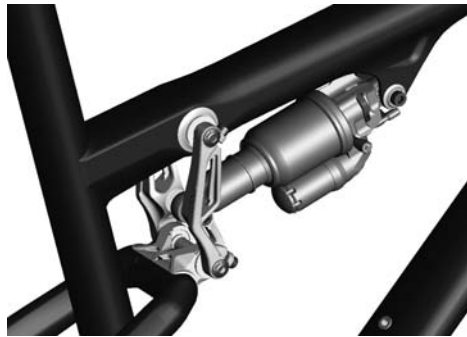

Important: After a dismantlement of the rear shock, both fixing bolts should be tightened with a tightening torque of 5Nm/44in-lbs.

If this is not done correctly the rear shock can be damaged.

SCOTT SEALED CABLE ROUTING:

The direct and straight cable system on all our full suspension models allows Smart Cable Routing which is very resistant against water and dirt.

To change the cables simply unscrew and open the cable brackets on the downtube.

MECHANICS HINT

The outer housing of the cables can also be fixed on the bottle cage with cable fixers, the two brackets below the cage are not needed anymore..



ADJUSTMENT OF SEATPOST-HEIGHT



Important:

The seatpost has to be inserted into the seat-tube at a minimum of 100mm.

Never use another seatpost diameter than 34.9mm or try to use a shim/reducer between seatpost and frame.

In case your bike is equipped with an integrated seatpost pls follow the instructions below to cut the seattube to your personal length.



integrated seatpost



standard seatpost

The seatpost of the Scott Spark needs to be cut and adjusted to the personal seat height of the rider.

The tool to do so is added to your Spark and will help to cut properly without any risk of damaging your seat tube.

To do so, pls follow the instructions given below:

1. Take the exact measure of the distance (d1) from the mid of axle of your pedal to the upper side of the saddle you use already on your "old" bike which is exactly adjusted to your seat position.



Important: pls note that the change to another saddle or pedal model might influence a lot the length of the seat tube!



2. Mount your pedals and saddle on the Spark bike. Fix the saddle with the M5 screws (4mm Allen key) by using a tightening torque of 5Nm (44 in-lbs).

Your Spark seat clamp allows you to vary the seat height for fine adjustment of +/- 10mm. For the cutting, position your seat clamp as low as possible and measure the distance (d2) from the mid of the pedal axle to the upper side of the saddle.

Remove the seat clamp and measure the distance (l) from the top of the seat tube: $l = d2 - d1$

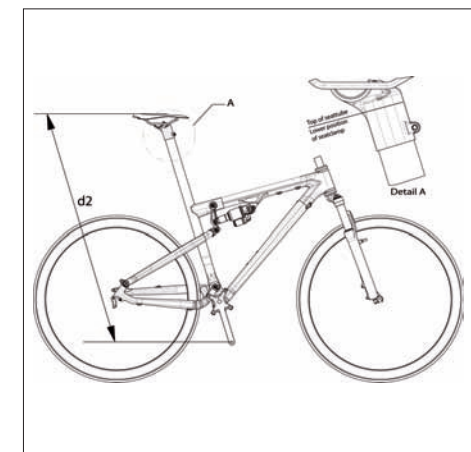

3. Indicate the length (l) you want to cut on the seat tube with a marker pen.
4. Slide the Spark Cutting Tool on the seat tube of Spark until the line of the marker is visible in the slot on the tool that will guide your saw blade.
5. Fix the two 5mm bolts with a 4mm Allen key with a tightening torque of 6 Nm (53 in-lbs).



6. Take a saw with a blade for cutting metal. **Please only use a 10D/24T teeth blade to make sure not to damage the carbon tube**

7. Cut the tube, remove the tool and take sandpaper to smoothen the edges of the cutting area.
8. Remount the seat clamp in its middle adjustment position (15mm over the top of the seat tube), fix the 2 M5 screws of the seat clamp (4mm Allen key) with a tightening torque of 5Nm (44 in-lbs)

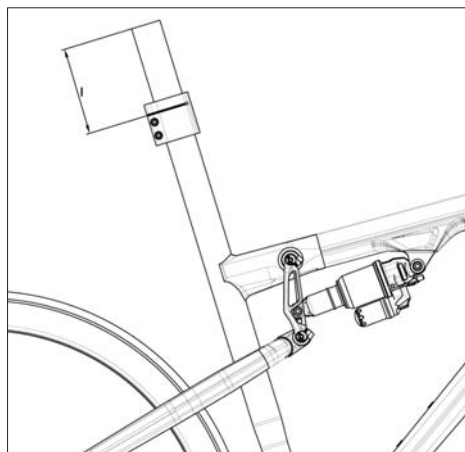
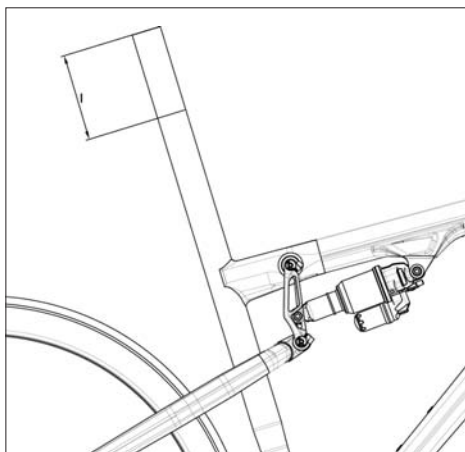

REPLACEABLE DROPOUT

On Spark bikes of model year 07 you can replace the rear derailleur hanger.

In case the replaceable hanger is damaged by a crash or accident you can order at your local Scott dealer the replacement part with Scott article number 206473



FRONT FORK SET-UP / CHANGE OF FRONT FORK

For the set up of the front fork please use the fork specific manual attached to the bike.

We recommend using front forks with a travel of 100mm, as this will not influence the geometry and alter handling of the bike.

PIVOT MAINTENANCE:

The pivot and bearings on SCOTT Spark are extremely easy to maintain.

An external treatment with a grease spray after every bike wash is all you have to do. We do not recommend heavy grease sprays since these will leave a film on the parts which is difficult to remove. We recommend the same for the chain also.

If you have to change the bearings you can order them included in a service kit at your local SCOTT dealer or buy them with international parts number as shown above in the specs list in a hardware store.

In case of a change of the bearings or of the rear swingarm you should contact your local SCOTT dealer as you need special tools for disassembly and assembly



WARRANTY

Model _____

Year _____

Size _____

Frame # _____

Shock # _____

WARRANTY

SCOTT bikes are made using the most innovative production and quality methods. They are equipped with best components of well known parts suppliers.

Doing so SCOTT warrants its frames and swingarms for five years (subject to compliance with maintenance ranges, see below) and SCOTT forks (provided it is a fork of SCOTT) for two years for defects in material and/or workmanship in case of purchase of completely assembled bikes.

This warranty of 5 years for the frames shall only be granted in case once a year a maintenance service has been effected according to maintenance requirements as set forth in this manual by an authorised SCOTT dealer.

The authorised SCOTT dealer shall confirm the effected annual maintenance service by stamp and signature.

In case such an annual maintenance service has not been effected the warranty of 5 years for the frame shall be reduced to 3 years.

Costs for maintenance and service have to be born by the owner of the SCOTT bike.

On Gambler the warranty period is limited to 2 years.

The warranty period starts at the day of purchase. This warranty is limited to the first buyer, what means the first person who uses the bike and only with the use it was made for. Furthermore, this warranty is limited to purchases via authorized SCOTT-dealers to the exclusion of purchases via internet auctions.

In case of a warranty claim the decision to repair or to replace the defective part is up to SCOTT. Non defective parts will only be replaced at the guarantee's own expense.

Fair wear and tear is not covered by the warranty. A complete list of all parts of wear and tear can be found in the next chapter of this manual.

In addition, you will find at the end of this manual a protocol for the handing over of the bike which will remain in copy at the SCOTT dealer after acceptance and signature of the consumer.

It is obligatory to show this protocol of handing over together with the defective part in case of a warranty claim given that it provides evidence of purchase. Otherwise no warranty is granted.

In principle, this warranty is granted worldwide. Claims must be made through an authorized dealer, for information regarding the nearest dealer, write or call this company or the national SCOTT distributor.

Normal wear, accident, neglect, abuse, improper assembly, improper maintenance by other than an authorized dealer or use of parts or devices not consistent with the use originally intended for the bicycle as sold are not covered by this warranty.

Hereby SCOTT grants a voluntarily manufacturer's warranty. Additional entitlements according to national warrant of merchantability are reserved.

For warranty info on the Nude TC shock please refer to the attached manual of DT Swiss.

