



# PaintShop® Pro X7

User Guide



# Contents

Welcome to Corel PaintShop Pro X7 . . . . .	1
The digital workflow . . . . .	9
Learning how to use Corel PaintShop Pro . . . . .	15
Workspace tour . . . . .	23
Getting started . . . . .	59
Reviewing, organizing, and finding photos . . . . .	99
Using the Adjust workspace . . . . .	139
Working with camera RAW photos . . . . .	143
Adjusting images . . . . .	149
Retouching and restoring images . . . . .	229
Merging exposures and content . . . . .	273
Working with selections . . . . .	291
Working with layers . . . . .	325
Working with masks . . . . .	369
Working with colors and materials . . . . .	385
Applying effects . . . . .	413
Working with text . . . . .	531
Drawing and editing vector objects . . . . .	551
Working with brushes . . . . .	593
Painting and drawing with the Art Media tools . . . . .	607

Working with advanced color features . . . . .	629
Customizing Corel PaintShop Pro . . . . .	657
Automating tasks . . . . .	705
Printing . . . . .	729
Sharing photos . . . . .	749
Creating images for the Web . . . . .	757



For people with a passion for photography, Corel® PaintShop® Pro is an easy-to-use, professionally powered, image-editing software that helps you achieve stunning photos and creative designs.

This section presents the following topics:

- What's new in Corel PaintShop Pro X7
- Installing and uninstalling Corel programs
- Starting and exiting the program
- Registering Corel products
- Updates and messages
- Corel Support Services
- About Corel



The availability of features depends on the version of the software you have.

## What's new in Corel PaintShop Pro X7

Corel PaintShop Pro X7 is defined by better performance, new tools that help you focus on enjoying the creative journey, and enhanced functionality in key areas. As always, working closely with our users was an essential part of creating this version of the easy-to-use photo-editing tool that many professional and enthusiast photographers and designers have come to rely upon.

## **New! Magic Fill**

Magic Fill is a content-aware feature that can make unwanted elements of your photos vanish. Use your favorite selection tools to select an area or object that you want to remove and apply Magic Fill to replace the selection with a background that matches the surrounding area—even when the surrounding area is textured or varied. For more information, see “Using Magic Fill to erase image areas” on page 243.

## **New! Shape Cutter and Text Cutter tool options**

Create photo objects instantly with the Shape Cutter and Text Cutter. The cutouts are filled with the underlying photo or imagery and placed in a new image with a transparent background—perfect for collage, scrapbook, and other creative photo projects. For more information, see “Filling cutout shapes with images” on page 561 and “Creating a text cutout filled with an image” on page 546.

## **New & Enhanced! Materials palette, custom palettes, and color harmonies**

The redesigned Materials palette makes it easier to select colors, and for the first time, you can build custom color palettes for your projects. A built-in dropper tool lets you sample colors in your images or from any application or Web page displayed on your desktop. Color swatches for the most recently used colors display automatically at the bottom of the palette and color harmonies help you choose colors that look great together. For more information, see “Working with colors and materials” on page 385.

## **Enhanced! Performance**

Many areas of PaintShop Pro have seen performance improvements. Some notable examples: Switching between workspaces is smoother, RAW image processing is speedier, and some brushes are up to 30% faster (Paint Brush, Airbrush, and the retouch brushes).

## **New! Smart Edge technology for brushes**

The Smart Edge brush mode lets you tap into content-aware technology to apply brush strokes only to specific areas that match the brush stroke sample area—no path or selection required. Smart Edge is available from the Tool Options palette for many brush-based tools. For more information, see “Choosing brush options” on page 595.

## **New & Enhanced! Drag-and-drop layers**

Building on the popular drag-and-drop improvements to layers in the last version of PaintShop Pro, PaintShop Pro X7 gives you even more control by letting you drag a layer from one image to another and drop it between or above a specific layer in the Layers palette.

## **New & Enhanced! A better way to start creative projects**

The New Image dialog box has been redesigned with new category buttons that help you find the right preset for your project. A new visual display helps you view the dimensions and proportions. For custom sizes and settings, you still have access to a full range of controls.

## **Enhanced! Redesigned Adjust and Effect dialog boxes**

Eight popular Adjust and Effect filters have been updated with a new layout: Selective Focus, Vignette, Retro Lab, Graduated Filter, Depth of Field, Red Eye Removal, Smart Photo Fix, and Digital Noise Removal. Bigger preview areas and an improved layout for the controls make it easier to get the results you want.

## **New! XMP support for RAW files**

Corel PaintShop Pro can now read and import data saved in XMP files. XMP sidecar files are created by many RAW image-editing applications, such as Corel® AfterShot™ Pro, as a way of saving image metadata without affecting the original RAW files. After editing in PaintShop Pro,

you can save the metadata to the associated XMP files. For more information, see “Working with XMP files” on page 147.

## Installing and uninstalling Corel programs

The Installer makes it easy to install Corel® programs and components.

Before installing

- Close all open programs. Note that antivirus software and firewall applications may affect installation.
- Ensure that you are logged in to your computer as Administrator or as a user with local administrative rights.

### 64-bit and 32-bit installation options

When you install the application, you have the option of installing the 64-bit version, the 32-bit version, or both versions. Which version should you choose? It really depends on your computer system and the plug-ins and other devices you use. If you have a 64-bit operating system, 4 or more GB of RAM, and lots of free disk space (need more than 700 MB free), then the most flexible option is to install the 64-bit and 32-bit versions. This will let you use any 32-bit plug-ins or other 32-bit compatible software with the 32-bit version of Corel PaintShop Pro, but still work with the 64-bit version of the application to take advantage of 6 or more GB RAM and other 64-bit optimized features.

Note: If you install 64-bit and 32-bit versions, the programs are listed separately and launched separately from the Windows Start menu or Start screen.

### To install Corel PaintShop Pro

- 1 Close any open applications.



- 2 Insert the DVD in the DVD drive or double-click the associated **.exe** file that you downloaded.  
If the setup does not start automatically, navigate to the DVD drive on your computer, and double-click **Setup.exe**.
- 3 Follow the instructions on your screen.

## To uninstall Corel PaintShop Pro

- 1 Open the Windows **Control Panel**.
- 2 In the **Programs** category, click the **Uninstall a program** link.
- 3 In the **Programs and Features** window, click **Corel PaintShop Pro X7** in the list of applications.
- 4 Click **Uninstall/Change**.
- 5 Follow the instructions on your screen.

## Starting and exiting the program

You can start Corel PaintShop Pro from the Windows taskbar or your desktop icon, and exit the program from the File menu.

## To start Corel PaintShop Pro

- From the **Start** menu, choose **All Programs ▶ Corel PaintShop Pro X7** or use the **Corel PaintShop Pro X7** application icon or tile on your desktop or **Start** screen.



If you installed the 64-bit version of the application, the name is listed as **Corel PaintShop Pro X7 (64-bit)**.

If you associate specific file formats, such as JPEG and TIFF, with Corel PaintShop Pro, you can double-click the associated file to start the program. For information about setting file format associations, see “Setting file format associations” on page 690.

## To exit Corel PaintShop Pro

- Choose **File** ► **Exit**.

## Registering Corel products

Registering Corel products is important to ensure that you receive timely access to the latest product updates, as well as valuable information about product releases. Registration also gives you access to free downloads, articles, tips and tricks, and special offers.

You can register the program immediately after you install it, or you can register at a later date.

You can register the program in one of the following ways:

- **online** — If you are connected to the Internet when you are prompted to register, you can launch the online registration. If no Internet connection is detected, you are presented with a list of options.
- **by phone** — You can call the Corel Customer Service Center nearest you.

For more information about registering a Corel product, visit [www.corel.com/support/register](http://www.corel.com/support/register).

## Updates and messages

Notification messages provide you with important information about your program. You can turn automatic program updates and messaging on or off. You can choose to check for updates and messages manually.

### To turn notification messages on or off

- 1 Click **Help** ► **Message Preference**.

- 2 Mark only the check boxes for the updates or messages that you want to receive.

### To update your program

- Choose **Help ▶ Check for Updates**.

### To check for messages

- Click **Help ▶ Messages**.

## Corel Support Services

Corel® Support Services™ can provide you with prompt and accurate information about product features, specifications, pricing, availability, services, and technical support. For the most current information on available support and professional services for your Corel product, please visit [www.corel.com/support](http://www.corel.com/support).

## About Corel

Corel is one of the world's top software companies, boasting some of the industry's best-known graphics, productivity and digital media products. We've built a reputation for giving customers more choice, and delivering solutions that are easy to learn and use. Our mission is simple: help people achieve new levels of creativity and productivity.

Corel's product lines include CorelDRAW® Graphics Suite, Corel® Painter®, Corel® PaintShop® Pro, Corel® VideoStudio®, Corel® WordPerfect® Office, Pinnacle Studio™, Roxio Creator®, Roxio® Toast® and WinZip®. For more information on Corel, please visit [www.corel.com](http://www.corel.com).



The digital workflow outlined below can help you understand how to best use Corel PaintShop Pro. It suggests a sequence for working with your digital images. Whether you want to organize, retouch, print or share, you can use the workflow described below as a guide.

## Bring photos into Corel PaintShop Pro

Bringing photos into Corel PaintShop Pro is as simple as opening the application in the Manage workspace and navigating to your favorite photo folders on your computer. The application automatically catalogs the folders that you navigate to, essentially “importing” them into the application, without duplicating any files.

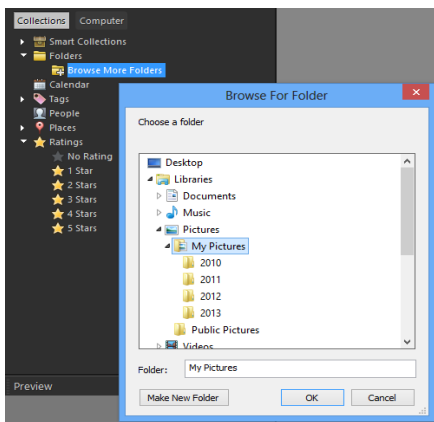

For more information, see “Getting photos into Corel PaintShop Pro” on page 60.

## Manage your photos

Digital photography gives you the freedom to experiment. The result is a large number of digital files, so photographers understand the need to manage those files by reviewing, culling, and identifying photos as early in the process as possible.

The Manage workspace lets you access all the tools you need to cull, rate, tag, and prepare photos for editing or sharing. Double-clicking a thumbnail opens a full-screen review mode called Quick Review. Search options and collections make it easy to find and work with the photos that you currently store on your computer.



*Quick Review is a full-screen review mode that opens when you double-click a thumbnail in the Manage workspace. You can use arrow keys to zoom and navigate.*

For more information, see “Reviewing, organizing, and finding photos” on page 99.

## Adjust photos quickly

The challenge for many photographers is finding the time to edit photos, so the Adjust workspace lets you move from photo to photo quickly and puts commonly-used editing tools at your fingertips. In some cases, this will be all the editing your photos will need.

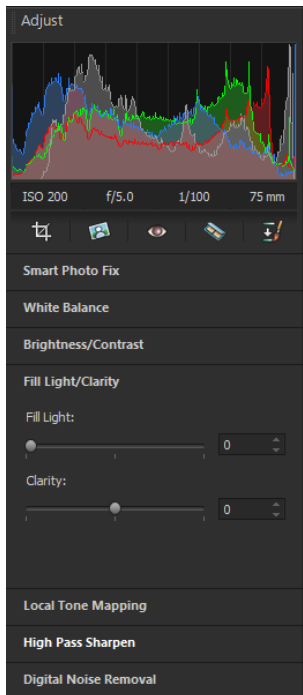

*The Adjust pane in the Adjust workspace gives you quick access to commonly-used editing options.*

After you edit photos, you can return to the Manage workspace to take advantage of multi-photo editing features such as Capture editing and Apply editing. Capture and Apply editing lets you copy edits made to a single photo and apply the edits to multiple photos. Images photographed under similar conditions can be fixed with amazing speed — no scripting required.

For more information, see the following topics:

- “The Adjust workspace” on page 26
- “Capturing and applying edits to multiple photos” on page 129

## Advanced editing and RAW files

Professional-level tools and features are available in the Edit workspace. For example, you can apply effects, add text, and use custom painting tools. You can also use layers to create highly editable composite images, isolate image areas with selections and masks, and access tone curves, histograms, and other advanced adjustment tools.



If you like the full control of working with RAW files, you can use the Camera RAW Lab to process your photos.



For more information, explore the following topics:

- “Adjusting images” on page 149
- “Retouching and restoring images” on page 229
- “Working with selections” on page 291
- “Working with layers” on page 325
- “Applying effects” on page 413
- “Working with text” on page 531
- “Working with camera RAW photos” on page 143

## Share photos

After you adjust and enhance your photos, you’ll want to share them. Along with printing, layout, and e-mailing options, there are sharing options that let you post directly to popular sharing sites, such as Facebook, Flickr, and Google+.



For more information, see the following topics:

- “Printing” on page 729
- “Sharing photos” on page 749

## Expanded creative options for DSLR photography

Many DSLR (digital single-lens reflex) camera owners are expanding their knowledge and looking for creative options. HDR (high dynamic range) features in Corel PaintShop Pro help you take advantage of bracketing features on your camera. You can also combine multiple photos with Photo Blend.

For more information, see the following topics:

- “Taking photos for HDR processing” on page 275
- “Combining photos by using HDR Exposure Merge” on page 276
- “Merging batches of photos into HDR images” on page 285
- “Combining photos with Photo Blend” on page 287

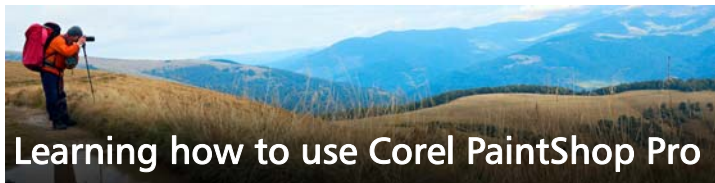

You can learn how to use Corel PaintShop Pro in various ways: by accessing the Help and videos, by using the Learning Center palette, or by exploring the Corel Guide and by visiting the Corel website ([www.corel.com](http://www.corel.com)), where you can access tips, tutorials, and information about training.



This section presents the following topics:

- Documentation conventions
- Using the Help system
- Corel PaintShop Pro X7 User Guide PDF
- Using the Learning Center palette
- Learning with video tutorials
- Using Web-based resources

## Documentation conventions

The following table describes important conventions used in the Help.

Convention	Description	Example
<b>Menu ▶ Menu command</b>	A menu item followed by a menu command	Choose <b>File ▶ Open</b> .
<b>drop-list</b>	A list of options that drops down when a user clicks a down arrow button	Choose an option from the <b>Selection Type</b> drop-list on the Tool Options palette.

Convention	Description	Example
<b>palette</b>	A window containing available commands and settings relevant to a specific tool or task	Double-click the name of the group on the Layers palette.
<b>mark and unmark</b>	Terms that refer to enabling or disabling check boxes by clicking them	To preserve the current print size, mark the <b>Maintain original print size</b> check box.
<b>Enter</b>	The <b>Enter</b> key on your keyboard	To save this gradient as a swatch that you can access later, click the <b>Add to swatches</b> button, type a name, and press <b>Enter</b> .
	A tip related to photography	For best results, use a tripod when taking photos for HDR processing.
	A note containing information that is important to the preceding steps. It may describe conditions under which the procedure can be performed.	Although you can apply the <b>Texture Preserving Smooth</b> command to the entire image, the command works best when you select the problem area.
	A tip containing suggestions for performing the preceding steps. It may present alternatives to the steps, or other benefits and uses of the procedure.	You can also right-click in the image to set the source point for the Clone tool.

## Using the Help system

The Help that is available from within the program is the most comprehensive source of information for Corel PaintShop Pro. The Help system provides two ways to find information. You can choose a topic from the Contents page, or use the Search page to search for specific words and phrases. You can also print topics from the Help.

### Online and local Help

If you are connected to the Internet, the application displays the online Help. When you are online, you have access to the latest information, videos, and helpful links. If no Internet connection is available, the application displays the local Help that is installed on your computer.

### To use the Help system

- 1 Do one of the following:
  - Click **Help** ► **Help topics**.
  - Press **F1**.
- 2 In the Help window, click one of the following tabs:
  - **Contents** — lets you browse through topics in the Help
  - **Search** — lets you search the full text of the Help for a particular word or phrase (no quotation marks required). For example, if you are looking for information about a specific tool or command, you can type the name of the tool or command, such as **Backlighting**, to display a list of relevant topics.

### You can also

---

Print a specific Help topic

Open a Help topic, and from the Internet Explorer menu, choose **File** ► **Print**.

---

## You can also

---

View Help for a dialog box

Click **Help** at the bottom of the dialog box.

---

## Corel PaintShop Pro X7 User Guide PDF

You can download the Corel PaintShop Pro X7 User Guide PDF to your computer or tablet, or you can print the pages you want. You can find the PDF in Help menu (**Help ▶ User Guide (PDF)**).

## Using the Learning Center palette

The Learning Center palette contains helpful information about Corel PaintShop Pro tasks, commands, and tools to help first-time users as well as experienced users get their work done faster. You can use the Learning Center in one of two ways: from the Home page, navigate through the task-based workflow, or simply click a tool in the Tools toolbar and follow the corresponding instructions that appear in the Learning Center palette.

Each task appearing on the Home page has its own topics with instructions that describe its related tools or commands. You can click a given topic to access a related tool or command. In this way, you can perform a task as you learn about it. You can also access the Help from the Learning Center palette to obtain additional information about a task.

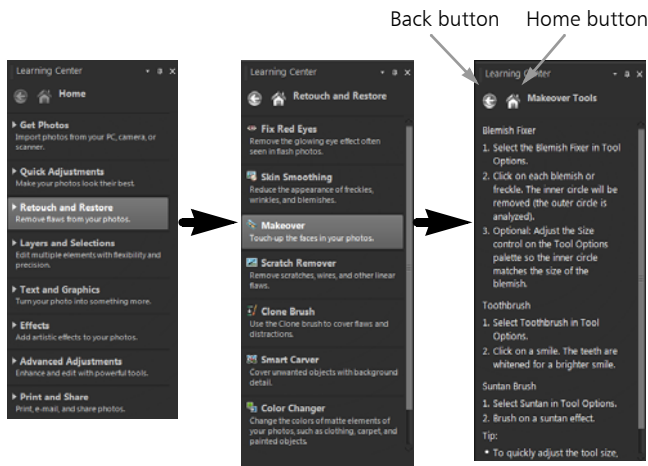

*From the Learning Center Home page, click a task, and then click a topic.*

## To display or hide the Learning Center palette

Edit workspace

- Choose **View** ▶ **Palettes** ▶ **Learning Center**.



The Learning Center palette is displayed by default. It appears along the right side of the Edit workspace.

## To use the Learning Center palette

### Edit workspace

1 From the Home page, click a task.

The topics related to the task appear.

2 Click a topic.

The procedure related to the topic appears.

- For topics describing a tool, the tool becomes active. The Tool Options palette and any other relevant palettes appear.
- For topics describing a command associated with a dialog box, the dialog box appears.

3 Read the procedure for using the tool or command.



Some tasks and commands are not available unless an image is open.

## Learning with video tutorials

The Discovery Center window (English only) lets you find and view a range of videos that help you learn about the application and photography.



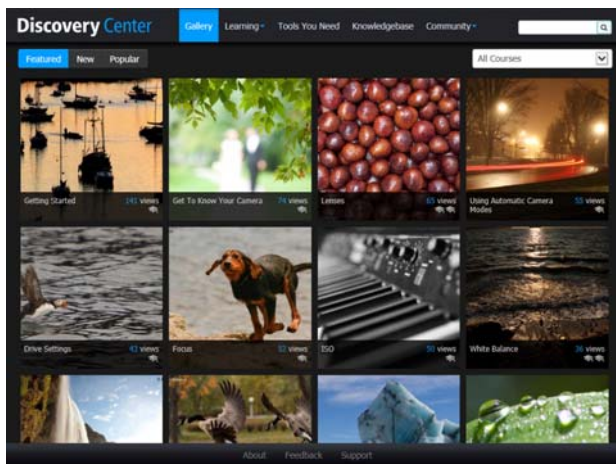

You can also find video links within some topics in the online Help and by visiting [www.youtube.com/corelpaintshoppro](http://www.youtube.com/corelpaintshoppro).

## To open the Discovery Center window

- Choose **Help** ► **Video Tutorials**.

## Using Web-based resources

From the Corel PaintShop Pro Help menu and the Corel website, you can access a number of Web pages dedicated to customer support and communities. You can find resources such as downloads, tutorials, tips, newsletters, newsgroups, and other online resources.

## To access Web-based resources

- From the **Help** menu, select one of the following website links:
  - **Corel Support** — this link takes you to the Customer Support Web page
  - **Check for Updates** — checks the Corel Update Service to see if there are updates to your copy of Corel PaintShop Pro

## To access Corel learning resources

- Use your Internet browser to go to [www.corel.com/paintshop](http://www.corel.com/paintshop), and click the **Resources** tab.



Corel PaintShop Pro includes three main workspaces that let you organize and edit your images: Manage, Adjust, and Edit.



The availability of features depends on the version of the software you have.

This section presents the following topics:

- Exploring the workspaces
- Switching between workspaces
- Choosing a workspace color
- Using palettes
- Using toolbars
- Using tools
- Customizing toolbars and palettes
- Using dialog boxes
- Viewing images
- Using shortcut keys
- Using context menus
- Using rulers, grids, and guides

## Exploring the workspaces

Corel PaintShop Pro consists of three workspaces:

- **Manage**
- **Adjust**
- **Edit**

Each workspace contains specific tools and controls to help you accomplish the task at hand quickly and efficiently.

You can save the workspaces, including all open images and their magnifications and screen positions, as well as positions and preferences of palettes, toolbars, dialog boxes, and windows. For information about using custom workspaces, see “Using custom workspaces” on page 659.

### **The Manage workspace**

When you open Corel PaintShop Pro, the Manage workspace appears as your default workspace.

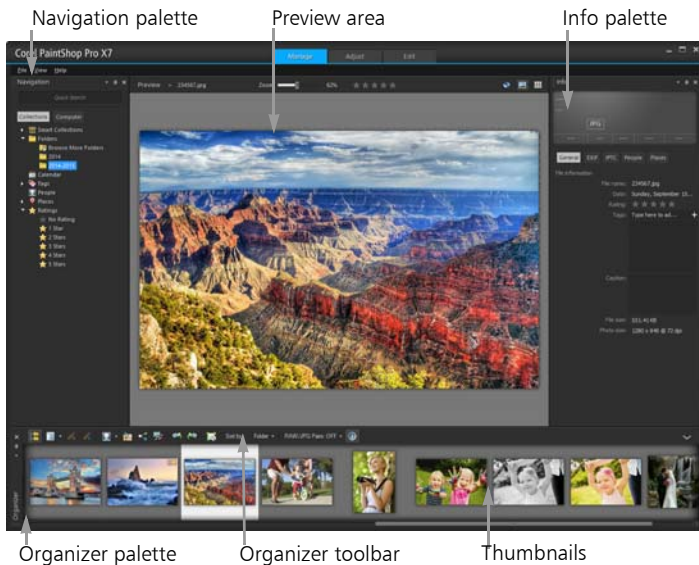

*The Manage workspace in Preview mode*

The Manage workspace consists of the following components:

- **Navigation palette** — helps you find and organize photos. You can use the Search box or click the Collections tab or Computer tab to display the folders on your computer, or you can sort photos by collection, tags, or ratings.
- **Preview area** — lets you choose between two views — a large single-image view or a multi-thumbnail view (expanded Organizer palette).
- **Info palette** — displays information about the selected image. It consists of a camera-style display of the settings used to take the photo and a tabbed area that lets you add information, such as tags and ratings, and access a full list of EXIF or IPTC data.

- **Organizer palette** — available in all three workspaces, this palette lets you select photos (as thumbnails) and includes a toolbar with a range of commands and options for managing photos. You can hide or show the tools by clicking the  button.

For more information about the Manage workspace, see “Reviewing, organizing, and finding photos” on page 99.

## The Adjust workspace

Adjust is your workspace for quick edits. It lets you fix and enhance your photos by offering a set of the most commonly-used tools.

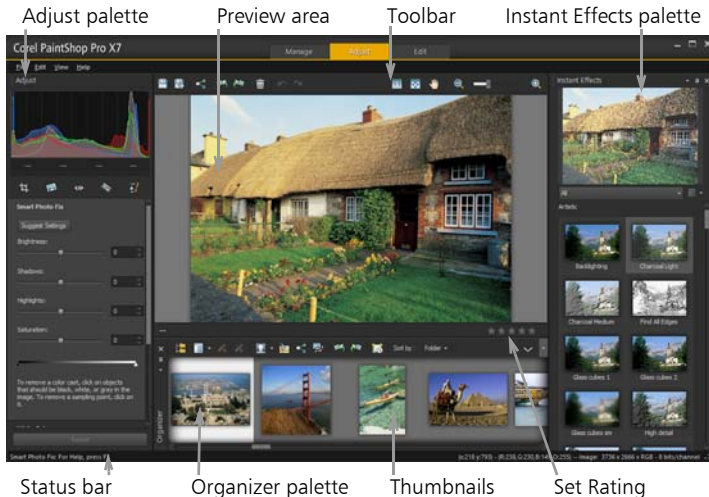

A photo displayed in the Adjust workspace

The Adjust workspace includes the following components:

- **Adjust palette** — displays tools and controls for adjusting photos
- **Preview area** — displays the photo selected in the Organizer palette

- **Toolbar** — displays buttons for accessing common saving and viewing commands
- **Instant Effects palette** — displays preset effects that you can apply to your photo
- **Status bar** — displays information about the selected tool
- **Organizer palette** — available in all three workspaces, this palette lets you select photos (as thumbnails) and includes a toolbar with a range of commands and options for managing photos. You can hide or show the tools by clicking the  button.
- **Set Rating control** — lets you assign ratings to each photo, so that you can quickly find your favorites

For more information about the Adjust workspace, see “Using the Adjust workspace” on page 139.

## The Edit workspace

The Edit workspace lets you access in-depth editing features. It includes menus, tools, and palettes that you can use to create and edit images. In addition to photo editing, it lets you perform painting and drawing tasks.



*A photo displayed in the Edit workspace*

The Edit workspace includes the following components:

- **Menu bar** — displays commands for performing tasks. For example, the Effects menu contains commands for applying effects to images.
- **Toolbars** — display buttons for common commands. For more information, see “Using toolbars” on page 32.
- **Palettes** — display image information and help you select tools, modify options, manage layers, select colors, and perform other editing tasks. For more information, see “Using palettes” on page 30.



- **Image window** — displays open files. You can choose from a tabbed view or a window view. For more information, see “Viewing images” on page 47.
- **Status bar** — displays information about the selected tool or menu command, as well as information about image dimensions, color depth, and pointer position. The status bar appears at the bottom of the workspace, and unlike other toolbars, it cannot be customized or moved. For more information about viewing image information, see “Displaying and editing photo information” on page 132.

## Switching between workspaces

Corel PaintShop Pro lets you switch between different workspaces quickly and easily so that you can accomplish your photo managing and editing tasks in the most efficient manner.

### To switch between workplaces

- At the top of the application window, click one of the following tabs:
  - **Manage**
  - **Adjust**
  - **Edit**

## Choosing a workspace color

You can choose from a variety of workspace colors — from dark to light. You can also choose a background color for the image window and preview windows.

### To choose a workspace color

- 1 Click **View** ► **Workspace Color**.

2 Choose one of the following colors:

- **Dark Gray** (default)
- **Medium Gray**
- **Light Gray**

## To change the background color

1 Click **View ▶ Background Color**, and choose a color.

## Using palettes

Corel PaintShop Pro contains many palettes that organize information and commands to help you edit your images. Some palettes appear automatically, others appear when you activate certain tools, and some palettes appear only when you choose to open them. You can easily turn a palette on and off by choosing **View ▶ Palettes**. Some palettes are available only in specific workspaces.

Palettes display information and may contain both controls and command buttons. Like toolbars, palettes can be moved from their default docked position. For more information about customizing palettes, see “Customizing toolbars and palettes” on page 40.

<b>Palette</b>	<b>Description</b>
Brush Variance	Lets you set additional brush options when you use a paint brush or any other raster painting tool. This palette is particularly useful when you use a pressure-sensitive tablet or a four-dimensional mouse. For example, you can vary the opacity of a brushstroke by applying pressure with the stylus. Some options also work well with a mouse.

<b>Palette</b>	<b>Description</b>
Histogram	Displays a graph of the distribution of red, green, blue, grayscale, hue, saturation, and lightness values in an image. You can analyze the distribution of detail in the shadows, midtones, and highlights to help you decide how to make corrections.
History	Lists the actions taken on the active image; lets you undo and redo adjacent or nonadjacent actions; and lets you create a Quicksript that can be instantly applied to other open images
Info palette	(Manage workspace) Displays information about the selected image. It consists of a camera-style display of the settings used to take the photo and a tabbed area that lets you edit and view information, such as tags and ratings, EXIF and IPTC data, and information about location and people.
Instant Effects	Provides quick access to thumbnails of preset effects that you can apply to your photos.
Layers	Lets you view, organize, and adjust settings for image layers
Learning Center	Displays information about workflow, tools, and commands to help you complete common tasks quickly and efficiently
Materials	Lets you choose colors and materials for painting, drawing, filling, and retouching
Mixer	Lets you place and mix pigments to use with the Oil Brush tool and the Palette Knife tool, allowing you to create realistic strokes with oil paints on Art Media layers
Navigation palette	Lets you find and organize photos

Palette	Description
Organizer	Lets you gather and display photos from various folders so that you can select, edit, e-mail, or print them. You can add, remove, and rename custom trays within the palette to match your workflow.
Overview	Displays a thumbnail of the active image; lets you set a zoom level, and displays image information
Script Output	Displays a list of your actions and results when you run scripts
Tool Options	Displays settings and controls for the active tool

## To display or hide a palette

Edit workspace

- Choose **View ▶ Palettes**, and click the palette name. Palettes that are currently displayed are denoted with a check mark .



You can display or hide a floating palette by pressing **F2**.

## To resize a palette

Edit workspace

- Drag the corner or edge of a palette.



You can also resize a docked palette by clicking the **Minimize palette**  or **Maximize palette**  button in the upper-right corner of the palette's title bar.

## Using toolbars

All three workspaces contain toolbars with buttons that are useful for performing common tasks. When you position the pointer over a

button, its name appears in a tooltip, and the status bar displays additional information about the command. In addition, in the Edit workspace, the Learning Center provides advice on using the tool.

The Edit workspace is the main access point for the following toolbars:

- **Effects** — displays commands for applying effects to your images
- **Photo** — displays commands for enhancing photos
- **Script** — displays commands for creating and running scripts
- **Standard** — appears by default toward the top of the workspace and displays the most common file-management commands, such as saving images, undoing a command, and cutting and pasting items
- **Status** — appears by default at the bottom of the workspace and displays information about the selected tool
- **Tools** — contains tools for painting, drawing, cropping, typing text, and performing other image-editing tasks
- **Web** — displays commands for creating and saving images for the Web

## To display or hide a toolbar

Edit workspace

- Choose **View ▶ Toolbars**, and click the toolbar that you want to display or hide.

A check mark beside the toolbar name in the menu indicates that the toolbar is displayed.



You can also display a toolbar by right-clicking any toolbar in the Edit workspace, choosing **Toolbars**, and then choosing the toolbar name.

To hide a specific toolbar, click the **Close** button  on its title bar.

You can display or hide a floating toolbar by pressing **F2**.

## Using tools

You can use the tools to perform a variety of image editing and creative tasks. When you hold the pointer over a tool, a tooltip displays the tool name and shortcut key, and the status bar displays hints for using the tool.

While the Adjust workspace contains a limited number of tools for quickly touching up your images, the Edit workspace contains a wide selection of tools for advanced image creation and editing. In the Edit workspace, some of these tools, such as the Crop, Move, and Text tools, reside in their own space on the Tools toolbar. Most tools, however, are grouped with other tools that perform similar tasks. A group of tools is denoted by a small flyout arrow on the right side of the active tool.

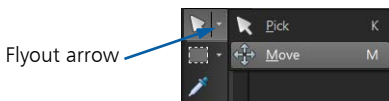























*Some tools are grouped together in flyouts. You can access all tools in a flyout by clicking the flyout arrow beside the active tool.*

For information about moving, hiding, and displaying the Tools toolbar in the Edit workspace, see “Using toolbars” on page 32.











Depending on the type of layer you are working on, some tools may not be available. For example, the Paint Brush and Clone Brush tools work only on raster layers; the Pen tool works only on vector layers. For more information about raster and vector layers, see “Understanding layers” on page 326.















The following table briefly describes each tool on the Tools toolbar of the Edit workspace. Some of these tools are also available in the Adjust workspace.







Tool	Description
 Pan	Lets you control which part of the image is visible in the image window
 Zoom	Zooms in when you click, or zooms out when you right-click. You can drag to define an area for zooming.
 Pick	Moves, rotates, and reshapes raster layers, and selects and modifies vector objects
 Move	Moves a raster layer or a vector layer on the canvas
 Auto Selection	Selects the edges of an area automatically when you enclose the area in a selection rectangle.
 Smart Selection Brush	Selects the edges of an area automatically when you brush over a sample area.
 Selection	Creates a geometrically shaped selection, such as a rectangle, ellipse, or triangle
 Freehand Selection	Creates an irregularly shaped selection
 Magic Wand	Makes a selection based on pixel values within a specified tolerance level
 Dropper	Lets you choose the foreground/stroke color by clicking or the background/fill color by right-clicking
 Crop	Trims or eliminates unwanted edges
 Straighten	Rotates a crooked photo to straighten it

Tool	Description
	Perspective Correction Squares the perspective of buildings or other objects that appear to be leaning
	Red Eye Quickly corrects the red-eye effect commonly seen in photos
	Makeover Provides five modes — Blemish Fixer, Toothbrush, Eye Drop, Suntan, and Thinify™ — which let you apply cosmetic fixes to subjects in your photos
	Clone Removes flaws and objects by painting over them with another part of the image
	Scratch Remover Removes wrinkles, wires, and similar linear flaws from digital photos, and removes scratches from scanned photos
	Object Remover Covers unwanted elements of a photo with a neighboring texture in the same photo
	Paint Brush Lets you paint on your image with colors, textures, or gradients
	Airbrush Simulates painting with an airbrush or spray can
	Lighten/Darken Lightens areas as you drag, or darkens areas as you drag with the right mouse button. This effect is stronger than the effects produced by the Dodge and Burn tools.
	Dodge Lets you lighten areas of a photo by clicking or darken areas by right-clicking
	Burn Lets you darken areas of a photo by clicking, or lighten areas by right-clicking



Tool	Description
 Smudge	Smears pixels by picking up new colors as you drag, or pushes pixels by not picking up new colors as you drag with the right mouse button
 Push	Pushes pixels by not picking up new colors as you drag, or smears pixels by picking up new colors as you drag with the right mouse button
 Soften	Softens pixels as you drag, or sharpens pixels as you drag with the right mouse button
 Sharpen	Sharpens pixels as you drag, or softens pixels as you drag with the right mouse button
 Emboss	Creates an embossed effect by suppressing color and tracing edges as you drag
 Saturation Up/Down	Makes colors more vivid as you drag, or less vivid as you drag with the right mouse button
 Hue Up/Down	Shifts pixel hue values up as you drag, or shifts them down as you drag with the right mouse button
 Change to Target	Recolors pixels while retaining detail
 Color Replacer	Replaces the background/fill color with the foreground/stroke color when you click and drag, or replaces the foreground/stroke color with the background/fill color when you right-click and drag
 Eraser	Erases raster layer pixels to transparency
 Background Eraser	Erases around the edges of the areas you want to keep in a photo

Tool	Description
 Flood Fill	Fills pixels of a similar tolerance level with the current foreground/stroke material when you click, or with the current background/fill material when you right-click
 Color Changer	Changes the color of an object while preserving the shading and luminosity of the original color
 Picture Tube	Places picture tubes, theme-based artistic elements, in your image
 Text	Places text on your image
 Preset Shape	Adds predefined shapes (such as callouts, arrows, and starbursts) to your image
 Rectangle	Creates a rectangle or square
 Ellipse	Creates an ellipse or circle
 Symmetric Shape	Creates symmetric or star-shaped objects
 Pen	Creates connected or unconnected lines, freehand curves, and Bézier curve segments
 Warp Brush	Shrinks, grows, twists, or distorts pixels
 Mesh Warp	Distorts a photo by dragging points along an overlay grid
 Oil Brush	Simulates oil brushstrokes on an Art Media layer
 Chalk	Simulates drawing with chalk on an Art Media layer
 Pastel	Simulates drawing with pastels on an Art Media layer

Tool	Description
 Crayon	Simulates drawing with crayon on an Art Media layer
 Colored Pencil	Simulates drawing with colored pencil on an Art Media layer
 Marker	Simulates drawing with an ink marker on an Art Media layer
 Watercolor Brush	Simulates watercolor brushstrokes on an Art Media layer
 Palette Knife	Simulates applying oil paint with a knife (instead of a brush) on an Art Media layer
 Smear	Smears whatever pigment you've applied to an Art Media layer
 Art Eraser	Erases whatever pigment you've applied to an Art Media layer

## Customizing toolbars and palettes

You can dock, float, resize, and move the toolbars and palettes to customize your workspace. When docking is enabled, toolbars and palettes can be automatically integrated into the workspace. When docking is disabled, toolbars and palettes can float anywhere on the screen without being integrated into the workspace.

You can keep the open palettes and toolbars fully displayed or roll them up when you're not using them.

### To set docking preferences

Edit workspace

- 1 Choose **View ▶ Docking Options**.

The Preferences dialog box appears.

- 2 In the **Allow Docking Of** group box, mark the palettes that you want to dock.



Even if a palette is set for docking, you can still place it anywhere in the workspace without docking it by dragging it while holding down **Ctrl**.

### To dock a toolbar or palette

Edit workspace

- Drag the toolbar or palette's title bar to one edge of the workspace.

The toolbar or palette snaps into place.



You can also dock a toolbar or palette by double-clicking its title bar.

## To float a toolbar or palette

Edit workspace

- 1 Do one of the following:
  - Place the pointer over the toolbar's handle. The pointer becomes a four-sided mover icon.
  - Place the pointer in the palette's title bar.
- 2 Drag the toolbar or palette away from the workspace edge.



The handle size and position vary, depending on the size of the toolbar and whether it is vertical or horizontal.



You can also double-click the toolbar's handle.

## To move a toolbar or palette

Edit workspace

- Drag its title bar to a new position.

## To resize a toolbar or palette

Edit workspace

- Drag a side or a corner of the toolbar or palette.

## To display all toolbars and palettes

Edit workspace

- Press **Ctrl + Shift + T**.

## To roll up a toolbar or palette

Edit workspace

- Click the **Auto Hide** pushpin button  on the toolbar or palette's title bar.

When the Auto Hide pushpin is pointing down, the toolbar or palette remains fully displayed.

When the Auto Hide pushpin is pointing to the left , the toolbar or palette rolls up when you move your pointer away.



If you perform an action in which the toolbar or palette remains in focus, the toolbar or palette remains displayed even after the pointer moves away. When you click anywhere else or perform another action, the toolbar or palette rolls up.

When you click away from the palette or toolbar with the Auto Hide button activated, it rolls up in one of two ways: If it's floating, only the title bar is visible; if it's docked, a tab appears with the palette or toolbar name.

Clicking the **Auto Hide** button again prevents the palette from rolling up.



To display the palette again, position your pointer over the tab.

## Using dialog boxes

Dialog boxes are windows that open when you choose certain Corel PaintShop Pro commands. You can use them to select and preview command options. All dialog boxes remember where you last positioned them on the screen and re-open in the same location.

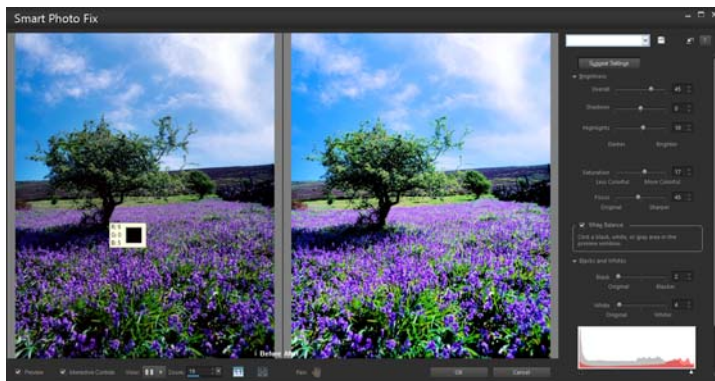

There are two styles of dialog boxes. The following Adjust and Effect filters use a larger layout to make it easier to use interactive controls: Depth of Field, Digital Noise Removal, Graduated Filter, Red Eye Removal, Retro Lab, Selective Focus, Smart Photo Fix, and Vignette.



*Some Adjust and Effect dialog boxes use a larger layout.*

For an example of the other style of dialog box, see “Choosing effects” on page 414.

Common features found in many dialog boxes include the following:

- **Before** and **After** panes — let you see the effect of the dialog box settings on your image before the effect is applied
- **Zoom** and **Pan** controls — let you zoom in and out on the preview areas, and change the current viewing area
- **Presets** — display saved settings, or scripts, that you can use to make quick changes to images. For more information, see “Using and creating presets” on page 721.
- **Reset to Default** button  — lets you reset dialog box settings to their initial values
- **Numeric edit** controls — let you select or enter numeric values
- **Color** boxes — let you select colors for a command setting
- **Randomize parameters** button  — lets you preview random settings.

- **Resize** handle — lets you resize the dialog box

## Using preview areas

Most dialog boxes that you use to correct images, apply effects, or modify selections contain Before and After panes that show the image with changes applied.

In some dialog boxes, you can show or hide the Before and After panes by clicking the Show/Hide Previews button:

▼ **Preview** — The Before and After panes are displayed.

▶ **Preview** — The Before and After panes are hidden.

When you hide the Before and After panes, you can still see the effects of the current settings on the image by marking the **Preview on Image** check box in the upper-right corner of the dialog box.

## Editing numeric values

To edit values in Corel PaintShop Pro dialog boxes, you can use the numeric edit control to enter values and change settings.

## Using color boxes

In some dialog boxes, a color box displays the currently selected color for a given control. When you move the pointer over the color box, the pointer changes to a dropper and displays the RGB values.

## Randomizing parameters

Many correction and effect dialog boxes contain a Randomize Parameters button  that lets you update settings with random values.



## To resize a dialog box

Edit workspace

- Drag the **Resize** handle .



You can also double-click the title bar to maximize the dialog box.

## To zoom in or out of the image preview

- Set the value in the Zoom control.

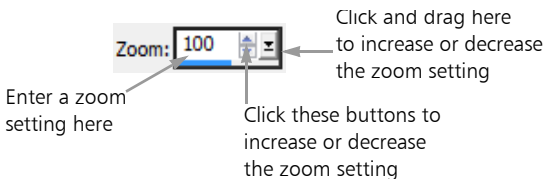

You can also expand the dialog box to create more room for the Before and After panes. For more information about resizing dialog boxes, see “To resize a dialog box” on page 45.

## To pan the image preview

Edit workspace

- 1 Move the pointer into the After pane.  
The pointer changes to a hand.
- 2 Drag the image.



You can also hold down the **Pan** button , and then center the selection rectangle over the part of the image you want to display.

## To proof changes in the main image window

Edit workspace

- Mark the **Preview on Image** check box.  
Any change to a dialog box setting will be applied to the main image window.

## To edit numeric values

Edit workspace

- Perform a task from the following table.

To	Do the following
Enter a specific value	Click in the control, press <b>Delete</b> or <b>Backspace</b> , and type a new value.
Increase or decrease the number by one	Click the up or down arrow.
Choose an approximate value	Click the slider.
Choose from the range of available settings	Move the slider.



If you enter a value that is out of range for the control, it turns red.



You can also double-click the number to highlight it, and type a new value.

## To choose a color from a dialog box

Edit workspace

- Perform a task from the following table.

To	Do the following
Select a color	Click the color box, and select a color from the Color dialog box.

To

Do the following

Select from recently used colors

Right-click the color box, and select a color in the Recent Colors dialog box.

## To randomize settings within a dialog box

Edit workspace

- Click the **Randomize parameters** button .



You can try a variety of settings by continuing to click the **Randomize parameters** button until you get the effect you want.

## Viewing images

You can view images in a tabbed format, in which a tab appears at the top of the image window. When you click a tab, the image in that window becomes the active image. You can also view images in windows, which you can move, resize, or close. You can open the same image in multiple tabs or image windows, which lets you see the image at different magnification levels.

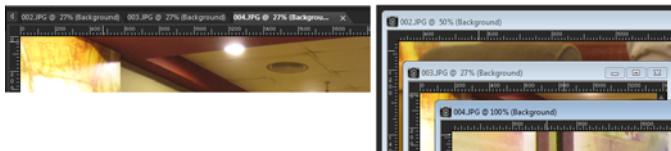

*The Tabbed Documents mode (left) lets you maximize your image viewing space. To view several images at the same time (right), turn Tabbed Documents mode off.*

If you have multiple images open, you can arrange the image windows to view them side by side or stacked in cascading order. You can also see a list of all open images.

If the image is larger than the image window, you can pan to view different parts of the image, or you can fit the window to the image. You can also see a thumbnail of the entire image in the Overview palette. For more information, see “Using palettes” on page 30.

The title bar at the top of the image window shows the filename and the magnification percentage. An asterisk after the filename indicates that the image has been modified and that those changes have not been saved.

If the image has an embedded watermark, a copyright symbol is displayed in front of its name. For more information, see “Using digital watermarks” on page 785.

## To enable or disable the tabbed image window option

Edit workspace

- Choose **Window ▶ Tabbed Documents**.



To view another image, click its tab. If an image tab is not in the current view, click the arrows in the upper-right corner of the image window to scroll left or right.

To close a tabbed-format image, click the **Close** button

## To move an image window

Edit workspace

- Drag the title bar.

## To resize an image window

Edit workspace

- Drag a corner of the image window.





When you resize an image window, you are not changing the size of the image.

## To minimize or maximize an image window

Edit workspace

- Perform a task from the following table.

To	Do the following
Minimize the image window to display only the title bar	Click the <b>Minimize</b> button  .
Maximize the image window to fill the workspace	Click the <b>Maximize</b> button  .
Restore the image window to its previous size	Click the <b>Restore Up</b> button  .

## To close an image window

Edit workspace

- Choose **File** ▶ **Close**.

If you have made unsaved changes to your image, you are prompted to save.



You can also click the **Close** button  on the title bar.

To close all windows, choose **Window** ▶ **Close All**.

## To make a copy of the active image

Edit workspace

- Choose **Window** ▶ **Duplicate**.

A copy of the active image opens. You can edit the copy independently of the original image.



You can also duplicate the active image by pressing **Shift + D**.

## To open multiple views of the same image

Edit workspace

- Choose **Window ▶ New Window**.

A new window opens with another view of the active image. When you make changes in one window, both windows are updated.

## To arrange multiple windows

Edit workspace

- Perform a task from the following table.

To	Do the following
Display cascading windows	Choose <b>Window ▶ Cascade</b> . The windows cascade from the upper left to the lower right of the workspace.
Display windows side by side vertically	Choose <b>Window ▶ Tile Vertically</b> . Windows are resized to fit within the workspace.
Display windows side by side horizontally	Choose <b>Window ▶ Tile Horizontally</b> . Windows are resized to fit within the workspace.

## To see a list of all open images

Edit workspace

- Click the **Window** menu.

The names of all open images appear at the bottom of the Window menu. The filenames are listed in the order in which they were opened.

## To view another area of the image

Edit workspace

- Perform a task from the following table.

To	Do the following
Pan the image	On the Tools toolbar, choose the <b>Pan</b> tool  , and then drag in the image. If any other tool is active, hold down the <b>Spacebar</b> , and then drag in the image.
Change the view horizontally or vertically	Drag the horizontal or vertical scroll bar.
Change the view by small increments	Press the arrow keys.
Pan in the Overview palette	Press <b>F9</b> to display the Overview palette, click the <b>Preview</b> tab, place the pointer inside the panning rectangle, and drag. You can also set the zoom level in the Preview tab of the Overview palette.

## To fit the image in the image window

Edit workspace

- Perform a task from the following table.

To	Do the following
Fit the window to the image	Choose <b>Window</b> ▶ <b>Fit to Image</b> .
Fit the image to the window	Choose <b>Window</b> ▶ <b>Fit to Window</b> .
Fit the image and the window to the screen	Choose <b>Window</b> ▶ <b>Fit to Screen</b> .

## Using shortcut keys

Corel PaintShop Pro lets you use shortcut keys to execute menu commands, select tools, display palettes, edit nodes on vector objects, and execute Organizer commands. All of the menu commands, including those for opening palettes, list their shortcut keys. Shortcut keys for tools are displayed when you move the pointer over a tool.

You can customize the shortcut keys. For more information, see “Customizing keyboard shortcuts” on page 666.

### To access menu commands by using shortcut keys

- Hold down **Alt**, and press the underlined letter in the menu item. For example, press **Alt + F** to open the File menu.



You can also scroll through the menus by using the arrow keys.

### To view all shortcut keys

Edit workspace

Manage workspace

- Choose **Help ▶ Keyboard Map**.

## Using context menus

Context menus provide quick access to commands that are specific to a tool, selection, palette, or other item. You can open a context menu by right-clicking the item.

### To view a complete list of context menus

Edit workspace

- 1 Choose **View ▶ Customize**.  
The Customize dialog box appears.
- 2 Click the **Menu** tab.



- 3 Click the **Select context menu** drop-list.  
All of the context menu names appear in the drop-list. If you want to open a specific context menu, select it.

## To use a context menu

- 1 Right-click an image, an empty area of a palette, a layer on the Layers palette, a thumbnail in the Organizer, or a toolbar.
- 2 Choose a command.

## Using rulers, grids, and guides

The Edit workspace displays the rulers by default. You can choose a ruler display in pixels, inches, or centimeters, change the color of the rulers, or altogether hide them.

### What is a grid?

A grid is a series of horizontal and vertical lines overlaying your image. Grid lines can help you position image elements. You can display or hide grids and set grid preferences for spacing and appearance. When you display grids, they appear in all open image windows.

### What are guides?

Guides are horizontal or vertical lines you position to overlay your image. With the rulers displayed, you drag guides onto your image to help with precision work, such as cropping, moving image elements, selections, as well as text and brushstroke placement. While grids place a series of horizontal and vertical lines at certain intervals, you place guides at the locations you want.

### Setting snapping

You can use snapping to align your brushstrokes and image elements precisely to the nearest grid line or guide. The snap influence controls

the distance, in pixels, that an element must be from a guide or grid line in order to snap to it. An item's center point snaps to a guide or grid if the center point is the closest part of the item to a grid or guide.

## To display the ruler, grid, or guides

Edit workspace

- Choose the **View** menu, and select one of the following:
  - **Rulers**
  - **Grid**
  - **Guides**



You must first display rulers before you can drag guidelines onto your image.

## To set ruler properties

Edit workspace

Manage workspace

- 1 Choose **File** ▶ **Preferences** ▶ **General Program Preferences**.  
The Preferences dialog box appears.
- 2 Choose **Units** from the list.
- 3 In the **Rulers** group box, choose an option from the **Display Units** drop-list.
- 4 Choose the ruler color by selecting one of the following options:
  - **Black on white** — displays black hash marks and numbers on a white background
  - **Toolbar colors** — displays black hash marks and numbers on a color background that is used in toolbars and palettes
- 5 Click **OK**.

## To set default or current grid properties

### Edit workspace

- 1 Choose **View ▶ Change Grid, Guide & Snap Properties**.

The Grid, Guide & Snap Properties dialog box appears.

- 2 Click the **Grid** tab.

The **Default settings** group box shows the default settings for the grid. The **Current image settings** group box shows settings for the grid in the current image.

- 3 Type or set a value in the **Horizontal grids** control to set the distance between horizontal grid lines (starting from the top of the image).
- 4 Type or set a value in the **Vertical grids** control to set the distance between vertical grid lines (starting from the left side of the image).
- 5 Choose a unit of measurement option from the **Units** drop-list.
- 6 Click **OK**.

### You can also

---

Choose a grid color

Click the **Color** box, and choose a color from the color palette.

---

Set the snap influence level

Type or set a value in the **Snap influence** control.

---

## To place a horizontal or vertical guide

Edit workspace

- 1 If the rulers are not displayed, choose **View ▶ Rulers**.
- 2 Choose **View ▶ Guides**.
- 3 Do one of the following:
  - To place a horizontal guide, click the top ruler, and drag a guide into position.
  - To place a vertical guide, click the left ruler, and drag a guide into position.

As you drag, the Status bar displays the guide's position (in pixels).

- 4 For further placement position, on a ruler, double-click a guide handle.

The Guide Properties dialog box appears.

- 5 Type or set a value in the **Guide position** control.
- 6 Click **OK**.

## To change the color of a guide

Edit workspace

- 1 On a ruler, double-click a guide handle.

The Grid, Guide & Snap Properties dialog box appears.
- 2 On the Guides tab, click the **Color** box, and choose a color from the color palette.
- 3 Click **OK**.

## To set the default properties for guides

Edit workspace

- 1 Choose **View ▶ Change Grid, Guide, and Snap Properties**.

The Grid, Guide & Snap Properties dialog box appears.
- 2 Click the **Guides** tab.

The **Default Settings** group box shows the default settings for guides. The **Current Image Settings** group box shows settings for the guides in the current image.

- 3 In the **Default Settings** group box, click the **Color** box, and choose a color from the color palette.

If you want to choose a recently-used color, right-click the **Color** box, and choose a color from the Recent Colors dialog box.

- 4 Type or set a value in the **Snap influence** control to specify the distance (in pixels) that an item must be from the guide in order for it to snap.
- 5 Click **OK**.

**Note:** You must choose the **Snap to Guide** command in the **View** menu.

## To delete guides from an image

Edit workspace

- 1 Choose **View ▶ Change Grid, Guide, & Snap Properties**.
- 2 Click the **Guides** tab.
- 3 Mark the **Delete guides** check box.
- 4 Choose one of the following options:
  - **From current image only**
  - **From all open images**
- 5 Click **OK**.



You can also drag a guide's handle until the guide is off the image area, or right-click a guide handle and click **Delete** in the Guide Properties dialog box.

## To snap to the nearest guide or grid line

Edit workspace

- From the **View** menu, choose one of the following:
  - **Snap to Guides**
  - **Snap to Grid**



You can bring your images into Corel PaintShop Pro in various ways: you can import photos that you have transferred to your computer, scan images directly into the application, capture images from the computer screen; or you can create an image.

After you bring your images into the application, you can access many basic commands that help you view images and image information. You can perform basic actions such as cut, copy, undo, and repeat.

This section presents the following topics:

- Getting photos into Corel PaintShop Pro
- Connecting with image scanners
- Opening and closing images
- Saving images
- Creating images
- Viewing images and image information
- Capturing images from the computer screen
- Zooming and panning
- Cutting, copying, and pasting
- Copying images into other applications
- Undoing and redoing actions
- Repeating commands
- Deleting images

- Files supported by Corel PaintShop Pro

## Getting photos into Corel PaintShop Pro

After you transfer your photos to your computer (by using Windows or the software for your camera), you can import your photos into Corel PaintShop Pro. You import photos by browsing to folders. The photos in the folders are then cataloged automatically in a database. This makes it easy to find, edit, and update the information for your photos.

Although you can browse to folders from any workspace, the Manage workspace is designed to make it easy to review and manage multiple photos. For more information about importing options, see “Browsing folders for photos” on page 103.

### To import your photos into Corel PaintShop Pro

Manage workspace

- 1 In the Navigation palette, click the **Collections** tab, and click **Browse More Folders**.
- 2 In the Browse For Folder dialog box, navigate to the folder you want.
- 3 Click **OK**.

The folder is added to the folder list and all the images are cataloged in the application database.



You can open the Navigation palette from any workspace by clicking the **Show/Hide Navigation** button  on the Organizer palette.



## Connecting with image scanners

Your scanning software may allow you to choose an application for scanning images. Many TWAIN, WIA, and USB scanners are compatible with Corel PaintShop Pro.

### 32-bit and 64-bit scanner compatibility

WIA (Microsoft Windows Image Acquisition) is supported by both the 32-bit and 64-bit versions of Corel PaintShop Pro.

TWAIN is supported by both the 32-bit and 64-bit versions of Corel PaintShop Pro. However, to work with the 64-bit version of Corel PaintShop Pro, your scanner must support 64-bit applications (in some cases, scanner drivers install to the 64-bit version of Windows, but do not support interaction with 64-bit applications). How can you tell? After you install the 64-bit scanner driver from the manufacturer, a file appears in the following location: Windows/twain\_64. If you do not see the twain\_64 folder and a file within the folder, then the driver does not support 64-bit applications. For more information, please refer to the scanner manufacturer's website.

## To get images from a scanner

Edit workspace

- 1 After installing the software that came with your scanner, connect your scanner to your computer.
- 2 In Corel PaintShop Pro, choose **File ▶ Import**, and click **From Scanner or Camera** (WIA option) or **TWAIN Acquire**, depending on the type of scanner.
- 3 Use the scanner's software to perform the scan.  
If you have set up your scanner to work with Corel PaintShop Pro, the image is displayed in the application after it is processed. The scanner's software may remain open, so you can either continue to acquire images or exit the software.



After scanning multiple photos at the same time, you can quickly create individual image files by using the **Crop as New Image** feature. For more information, see “To create a new image by cropping” on page 162.

After cropping an image, you might notice that the Width and Height values on the Tool Options palette are each set at 0.100. These settings do not reflect the cropped image size. To see the image size dimensions after cropping, choose **Image ▶ Image Information**.

## Opening and closing images

You can open most image formats in Corel PaintShop Pro. You can open the images by using the menu bar or by using the Manage workspace. You can associate specific file formats with Corel PaintShop Pro, such as JPEG, TIF, or PNG, so that these files will open in Corel PaintShop Pro when you double-click them. For more information about setting file format associations, see “Setting file format associations” on page 690. For a list of the file formats that you can open in Corel PaintShop Pro, see “Files supported by Corel PaintShop Pro” on page 94. For information on RAW files, see “Supported RAW file formats” on page 143.

### To open an image

Edit workspace

- 1 Choose **File ▶ Open**.
- 2 In the **Look in** drop-list, choose the folder where the file is stored.
- 3 Click the name of the file that you want to open.  
If you want to open multiple files, hold down **Ctrl**, and click the filenames.
- 4 Click **Open**.

## You can also

---

View information about an image	In the Open dialog box, click the filename, and click <b>Details</b> .
View a thumbnail in the preview area	In the Open dialog box, mark the <b>Show preview</b> check box.
Run a script on the files as they open	In the Open dialog box, mark the <b>Enable Pre-processing</b> check box, and choose a script from the drop-list.

---

## To open a recently viewed file

Edit workspace

- Choose **File ▶ Recent Files**, and choose the filename.



By default, the **Recent Files** menu lists four recently viewed files. You can choose to list up to 10 files. For more information, see “To set the number of files that appear in the Recent Files list” on page 678.

## To open an image from the Manage workspace

Manage workspace

- Click a thumbnail to select the file.

To view thumbnails from another folder, click **Browse More Folders** on the Navigation palette, and from the Browse For Folder dialog box that appears, choose the folder you want. The folder appears in the Folders list.

You can work with the file in the Manage workspace, or click the **Adjust** tab or **Edit** tab to edit the file in another workspace.

## To open a RAW photo image

Edit workspace

- Do one of the following:

- Choose **File ▶ Open**.
- Double-click on a RAW image thumbnail.
- Hold down **Ctrl**, and click the filenames or thumbnails to open multiple files.

The Camera RAW Lab dialog box opens. This dialog box lets you adjust the settings that are stored with the RAW photo file.

## To close an image

- Choose **File ▶ Close**.



In the Edit workspace, you can also close an image by clicking the **Close** button  above the image.

## Saving images

Before you save an image, you need to consider the file format in which you want to save it, and you must ensure that you don't overwrite an original image that you may need in the future.

The PspImage file format of Corel PaintShop Pro supports layers, alpha channels, and other features used in creating images. It is recommended that you save and edit your images as PspImage files. You can then save the files to common file formats. You can also use the **Save for Office** command if you want to optimize your images for placement in another application, such as a page layout, e-mail, or Web page design application.

The following list provides basic information about common file formats:

- **JPEG** — a standard file format for digital photos that is suitable for e-mail and the Web. It uses lossy compression, which ensures a small file size but entails a loss of image data each time you save.

For this reason, this format is not recommended for editing photos unless a high quality setting is used. This file format supports EXIF and IPTC data, which can be used to provide information about the photo, such as when a photo was taken.

- **TIFF** — a standard file format for printing and sharing images between programs. This file format uses non-lossy compression. Although you do not lose image data when you save the file, the larger file size is less suitable for e-mail and the Web. TIFF can save data in the CMYK color mode for printing, and it supports EXIF and IPTC data.
- **PNG** — a file format widely used for Web images. It uses non-lossy compression to reduce the file size without losing image data.
- **RAW camera formats** — a file format typically used by professional photographers. RAW camera formats provide uncompressed, unprocessed image data and gives you the most control over how an image is processed. You must have a camera that captures digital image in a RAW format, and you need software that lets you open and work with the file, such as Corel PaintShop Pro.

You can save a PsplImage file with or without compression. Both compression methods that Corel PaintShop Pro uses are lossless and reduce the file size without losing any image information.

Uncompressed files require more disk space.

Corel PaintShop Pro uses the following compression methods:

- **Run length encoding (RLE)** — a fast compression method, which compresses most multilayer images to about 75 percent of their original size. This method works well with images that contain large areas of the same color.

- **LZ77 compression** — a slower compression method that compresses most images to smaller sizes than with the RLE method. This method works well with photorealistic images.

When you save a new image, Corel PaintShop Pro lets you select its location, name, and file format. When you save an image and then edit it, the image title bar displays an asterisk, or modifier tag, after the filename to indicate that the file has been modified. This tag disappears each time you save your work.

You can also automatically save your files at specific intervals to avoid losing your work if your computer shuts down unexpectedly. For more information, see “Setting Autosave preferences” on page 699.

If you want to save a version of a file, you can save a copy of an image. This is useful when you want to apply effects to an image but keep the original file.

***Important!** The Auto-Preserve Original preference setting can help you avoid overwriting original images. By default, this feature is on. For more information on this preference setting, see “Setting Auto-Preserve preferences” on page 683.*

## To save a new image

Edit workspace

- 1 Choose **File ▶ Save**.

The Save As dialog box appears.

- 2 From the **Save in** drop-list, choose the folder in which you want to save the file.
- 3 In the **File name** field, type a name for the file.
- 4 In the **Save as type** drop-list, choose a file format. The most commonly used formats are listed first.

If you want to change the default settings for the file format (for example compression or color profile), click **Options**, and choose the settings you want.

- 5 Click **Save**.



You can also save your work by clicking the **Save As** button  on the Standard toolbar to avoid overwriting your current file. You can save in the last-used file format by choosing **File ▶ Preferences ▶ General Program Preferences**, and clicking **Display and Caching** from the list on the left side. In the Presentation group box, mark the **Re-use last type in the file save-as dialog** check box.

## To save your work

Edit workspace

- Choose **File ▶ Save**.

If the Auto-Preserve Originals preference setting is enabled, and this is the first time you've attempted to save changes to this image, you are prompted to save a copy of the original unedited image. If Auto-Preserve Originals is not enabled, the original image is overwritten by the modified image.



You can avoid overwriting the current file by using the **Save As** command.



You can also save your work by clicking the **Save** button  on the Standard toolbar.

## To save a copy of an image

Edit workspace

- 1 Choose the **File ▶ Save Copy As**.

The Save Copy As dialog box appears.

- 2 From the **Save in** drop-list, choose a folder in which to save the image.

If you want to create a new folder for the image, click the **Create New Folder** button.

- 3 In the **File name** box, type a name for the file.

If you want to save the file in a different format, select the format from the **Save as type** drop-list. The most commonly used formats are listed first.

If you want to change the default settings for the file format (for example compression or color profile), click **Options**, and choose the settings you want.

- 4 Click **Save**.

## To save images for office applications

Edit workspace

- 1 Choose **File ▶ Save for Office**.

The Save for Office dialog box appears.

- 2 From the **Save in** drop-list, choose a folder in which to save the image.

If you want to create a new folder for the image, click the **Create New Folder** button .

- 3 From the **Optimize** drop-list, choose one of the following:

- **Desktop Printing** — sets the image resolution to 200 dpi. This option is ideal for when you are working in a general page layout application and you want high-quality images but not an overwhelming file size.
- **Professional Printing** — sets the image resolution to 300 dpi. This option is ideal for when you need the highest image quality.



- **Screen or e-mail** — sets the image resolution to 96 dpi. This option is ideal for when you want a smaller file size that can be shared or displayed quickly.
- 4 In the **File name** box, type a name for the file.
  - 5 Choose a file format from the **Save as type** drop-list.
  - 6 Click **Save**.

## You can also

Define the maximum image size	Mark the <b>Advanced Settings</b> check box, and then adjust the <b>Width</b> and <b>Height</b> settings. Choose a unit of measure from the drop-list on the right.
Adjust the image quality	Mark the <b>Advanced Settings</b> check box, and then choose a resolution from the <b>Image quality</b> drop-list.
Use the most recent settings from the Save to Office dialog box	From the <b>Optimize</b> drop-list, choose <b>Last Used</b> .
Use the default settings for the Save to Office dialog box	From the <b>Optimize</b> drop-list, choose <b>Default</b> . The settings are the same as the default <b>Screen or e-mail</b> settings.

## Creating images

The New Image dialog box is like a start screen for your creative projects. You can choose a preset, such as a standard page, photo size, or Facebook timeline cover, or you can create a custom image. The section below describes some of the settings available.

There are two types of computer graphics: raster and vector. With Corel PaintShop Pro, you can create both types of images. You can also create an image with both raster and vector layers. It is important to

understand the differences between these two data types before you begin working with them.

## **Raster graphics**

Raster images are composed of individual elements, called pixels, which are arranged in a grid. Each pixel has a specific location and color. If you magnify raster data, you can see the individual pixels as squares of colors. Raster images contain a fixed number of pixels, so when you magnify the image you are magnifying the display size of the pixels. As a result, raster images may display jagged rather than smooth edges when magnified on screen or when printed at a large magnification.

An object in a raster image is defined by its pixels. For example, the front door in an image of a house is made up of a mosaic of pixels at certain locations in the image. In bitmap images, you edit pixels rather than objects or shapes.

Raster images can display subtle changes in tones and colors, so they are most often used for images like photographs and digital artwork.

## **Vector graphics**

Vector graphics use geometric characteristics — lines, curves, and their locations — to define objects. For example, a door in a graphic of a house is made up of a rectangle that has a certain width and height, is placed at a specific location, and is filled with a certain color. In vector images, you edit objects or shapes rather than pixels.

Vector graphics do not lose clarity or detail when they are scaled or printed, regardless of the change in size or resolution. For this reason, vector graphics are suited to technical illustrations or corporate logos.

## Choosing to work with raster or vector data

With Corel PaintShop Pro, you create and edit raster and vector data on separate layers. With some tools you create raster data (like brushstrokes with the Paint tool), and with other tools (like the Text and Preset Shapes tools) you can choose whether you want to create raster or vector data.

In general, it is best to use a vector object if you need to edit it as an element separate from other parts of the image. For example, if you add a star to an image, you may want to change its size, color, or location. You can make these changes more easily if the star is a vector object. You can create raster data on separate layers, which can be easily edited or moved.

To apply tools or commands to vector objects that work only on raster data (such as the painting tools or the Effects commands), you can create a raster selection of a vector object and then paste the selection to a new raster layer.

## Understanding image size, resolution, and color depth

Before you create a new image, you need to consider how you will use it. For example, will you display the image on a website, send it as an e-mail attachment, or print it? How you use the image helps you determine its size, resolution, and color depth.

**Image size** is represented by the physical dimensions of the image. When you create a new image or resize an existing image with Corel PaintShop Pro, you can define image height and width in pixels, inches, millimeters, or centimeters.

The following are guidelines for choosing a unit of measure:

- If you plan to print the images, use inches or centimeters. By starting with the final image dimensions, you can produce an image that fits the page.
- If you plan to export the images to another application (such as a word-processing application), and then resize and print them, you can use any of the options.
- If you plan to display the images on the screen, use pixels.

You can resize an image after creating it, but doing so may result in loss of image data. For more information about resizing images, see “Retouching and restoring images” on page 229.

**Image Resolution** is measured in pixels per inch (ppi) or pixels per centimeter. Low resolution can cause pixelation, a problem in which large pixels produce coarse output. High resolution can increase an image’s memory requirements without producing a proportional increase in its quality.

**Color Depth** is measured according to the number of colors that a pixel can display. Each pixel’s color information is stored in bits — from 1 to 48 bits. In a 1-bit image, each pixel can display only one of two colors (black or white). In a 24-bit image, each pixel can display 1 of 16 million colors. Images with a color depth of 16 million colors look good, but they also require more memory to store and edit. Not all computer monitors can display 16 million colors, so some file formats limit the number of supported colors. For example, GIF images, a popular format for the Web, contain up to 256 colors (8-bit depth).

Many of the commands in Corel PaintShop Pro for applying effects and correcting images work on 16 million–color images only. Therefore, it’s best to create most images in 16 million colors. When you have finished working on the image, you can decrease its color depth and save it in another format.

You can create an image by using the **New** command in the **File** menu, or by copying aspects of an existing image. When you use an existing image as the source of your new image, you can copy the entire image or an individual layer. You can also create an image from any graphic data copied to the Clipboard from Corel PaintShop Pro.

When you create a new image in Corel PaintShop Pro, you can specify its dimensions, resolution, and type. The options available depend on the type of graphic you want to create. If you're uncertain as to what type of graphic you need for your project, or which settings to choose, review the information in the following procedure. For more information about creating Art Media graphics, see "Painting and drawing with the Art Media tools" on page 607.

## To create an image

Edit workspace

- 1 Choose **File ▶ New**.

The **New Image** dialog box appears.

- 2 To choose a preset, click one of the category buttons on the left, and choose a preset. To adjust the preset, or to define a custom image, follow the steps below.
- 3 In the **Image Dimensions** group box, type or set values for the following controls:
  - **Units** — specifies the unit of measure
  - **Width** — specifies the width of the new image
  - **Height** — specifies the height of the new image
  - **Resolution** — specifies number of pixels contained in the chosen unit of measure

If you want to choose preset dimensions, choose an option from the **Load Preset** drop-list.

- In the **Image Characteristics** group box, choose one of the following options:
  - **Raster Background** — suitable for most graphics and painting tasks
  - **Vector Background** — suitable for vector graphics
  - **Art Media Background** — lets you use the Art Media tools
- Choose an option from the **Color depth** drop list.

If you chose the **Raster Background** option, you can choose a background color for the image by clicking the color box and choosing a color from the Material Properties palette. To choose a transparent background (for 8-bit or 16-bit images only), mark the **Transparent** check box.

If you chose the **Art Media Background** option, you can choose a canvas texture from the **Select the canvas texture** drop-list. If you want to choose a color for the canvas, mark the **Enable fill color** check box, click the color box, and choose a color from the Color dialog box.

- Click **OK**.



The **Memory Required** field displays the amount of memory required for the image. Your computer's available memory should be at least two to three times the value displayed in the **Memory Required** field. To reduce the memory requirement, you can reduce the resolution or the dimensions of the image.

For more information on choosing colors or materials, see "Using the Materials palette" on page 385.

## To duplicate an image

Edit workspace

- Open the image you want to duplicate.
- Choose **Window ▶ Duplicate**.

A new window containing a copy of the image appears in the workspace.

## To create an image from a layer

Edit workspace

- 1 On the Layers palette, click the layer you want to copy.
- 2 Choose **Edit**, and click one of the following:
  - **Copy**
  - **Cut**

The current layer is placed on the Clipboard.

- 3 Choose **Edit ▶ Paste As New Image**.

A new window containing the layer appears in the workspace.

## To create a new image from a layered image

Edit workspace

- 1 On the Layers palette, click the layer you want to copy.
- 2 Choose **Edit ▶ Copy Special ▶ Copy Merged**.  
All layers are copied to the Clipboard.
- 3 Choose **Edit ▶ Paste As New Image**.

A new image window appears in the workspace. The new image contains all layers merged into one raster layer.

## To create an image from the Clipboard contents

Edit workspace

- 1 Copy a selection or layer of an image, or an item from another program.
- 2 Choose **Edit ▶ Paste As New Image**.

The Clipboard contents are pasted as a new image.



If the **Paste As New Image** command is grayed out, then the data you have copied to the Clipboard cannot be pasted as a Corel PaintShop Pro image.

A dialog box may appear and request additional information, such as the width and height of the new image window. You can change your preferences so that Corel PaintShop Pro does not prompt you for size and options when you paste data. For more information about setting file format preferences, see “Setting file format preferences” on page 684.

## Viewing images and image information

When you open an image in Corel PaintShop Pro, it appears in an image window. The title bar of the image window displays the image filename and the level of magnification applied to the image. An asterisk after the filename indicates that the image has been modified and that the changes have not been saved.

You can view basic image information, such as the height and width of an image (in pixels) and its color depth. You can also view detailed information for the image, such as its resolution, color depth, layers and alpha channels, and EXIF data. You can also view the number of unique colors in an image.

You can also view and edit image information in the Info palette that displays in the Manage workspace. For more information, see “Displaying and editing photo information” on page 132.

The EXIF Information tab of the Image Information dialog box lets you view EXIF data for digital camera photos. When you take a photo with a digital camera, the camera attaches information to the image, such as the date and time that it was captured, the exposure, and the flash



settings. When you load a photo from a digital camera into Corel PaintShop Pro, you can view this extra information.

You can expand the workspace to preview an image without the menus, toolbars, or palettes visible.

The Status bar, which is located at the bottom of the application window, displays the cursor position, height and width in pixels, and color depth for the current image.

## To view digital photo information

Edit workspace

- 1 Open an image.
- 2 Choose **Image ▶ Image information**.
  - Click the **Image Information** tab to view the filename, file format, image dimensions, resolution, color depth, modification status, number of layers and alpha channels, and the amount of RAM and disk space used for the image. This page also displays the image's selections, masks, alpha channels, and Undo storage.
  - Click the **Creator Information** tab to view or edit the image's title, artist's name, copyright, description, date of creation, and date of modification.
  - Click the **Watermark Information** tab to view and add information about Digimarc watermarking.
  - Click the **EXIF Information** tab to view information for images taken with digital cameras. In the **Section** group box, mark the check boxes for the information you want to display: **Input Device**, **Artist**, **Date**, **Image**, **Shot Conditions**, **GPS**, or **Makernote**. Some items are editable (as denoted by an asterisk). To add customized text for an editable item, click in the **Value** column, and then type your custom information.



You can also add IPTC data to the image information by using the Advanced Creator Information dialog box. This can be useful for photojournalists, for example, who may need to record IPTC data about when and where a photo was shot, and how urgently the photo needs to be reviewed. To access this dialog box, click the **Creator Information** tab, and then click **Advanced**.

EXIF and IPTC data is also available on the Info palette in the Manage workspace.

## To view image color information

Edit workspace

- Choose **Image ▶ Count Image Colors** to display the number of unique colors in the image.

## To view layer color information

Edit workspace

- Choose **Layers ▶ Count Layer Colors** to display the number of unique colors in the current layer.

## To view an image on the full screen

Edit workspace

- Choose **View ▶ Full Screen Preview**.

The workspace disappears, and the image appears at its current magnification.



To return to the Corel PaintShop Pro workspace, press any key.

## Capturing images from the computer screen

Corel PaintShop Pro lets you capture images from your computer screen. Captured screens can then be embedded in documents such as reports, training guides, presentations, and Web pages.

To initiate the capture process, you must choose settings and then press a hot key, right-click, or set a delay timer. You can define your own hot key. You can also specify the delay period, so that you can set up elements such as menu lists or flyouts before completing the capture.

You can specify the window elements you want to capture. For example, you can capture the active window, a menu, an image, or a part of an image. However, hot keys and right-clicking cannot be used for capturing user-defined areas.

You can also capture a series of images. Each image is assigned a value and placed in order in the series. You can open the series of images in a graphics or word-processing application.

If you frequently capture screens, you may want to create a new, customized toolbar containing the icons for the screen capture command. For more information, see “Customizing toolbars” on page 663.

### To specify a method for capturing screens

*Edit workspace*

- 1 Choose **File ▶ Import ▶ Screen Capture ▶ Setup**.
- 2 In the **Activate capture using** area, choose one of the following options:
  - **Right mouse click** — lets you capture screen contents by right-clicking

- **Hot key** — lets you use a keyboard shortcut to capture screen contents. Choose a key or key combination from the drop-list.
- **Delay timer** — lets you capture screen contents after a specified delay. Type a number in the seconds box.

## To specify capture settings

Edit workspace

- 1 Choose **File ▶ Import ▶ Screen Capture ▶ Setup**.
- 2 In the Capture area, choose one of the following options:
  - **Area** — captures the area of the screen that you select
  - **Full screen** — captures the entire screen
  - **Client area** — captures the contents of the active program
  - **Window** — captures the active window
  - **Object** — captures an object within the program that you select, such as a menu bar, toolbar, icon, or document window
- 3 Click **OK**.

## To capture an image or series of images

Edit workspace

- 1 Choose **File ▶ Import ▶ Screen Capture ▶ Setup**.  
If you want to capture multiple images, mark the **Multiple Captures** check box.  
If you want to include the pointer in the capture, mark the **Include Cursor** check box in the **Options** group box.
- 2 Click **Capture Now**.
- 3 Set up the image you want to capture.  
If you want to capture an area of the screen, marquee select that area. If you want to capture an object, click the object.
- 4 Press the hot key or right-click.



If you marked the **Multiple captures** check box, you can now capture another image. Press the hot key, or right-click, for each capture. When you are finished, click the Corel PaintShop Pro button on the Windows task bar. The images appear in the workspace.

## Zooming and panning

By default, images that you open in Corel PaintShop Pro appear at a magnification level that allows the full image to appear in the workspace. You can zoom in to get a closer look at image detail or zoom out to view a larger portion of the image. You can also magnify a specific area of an image.

You can view image areas that fall outside the current image window. For example, when you are working at a high magnification level, you can pan or jump to a different image area without having to adjust the magnification level. When an image is too large to fit within its window, scroll bars appear on the bottom and right sides of the image.

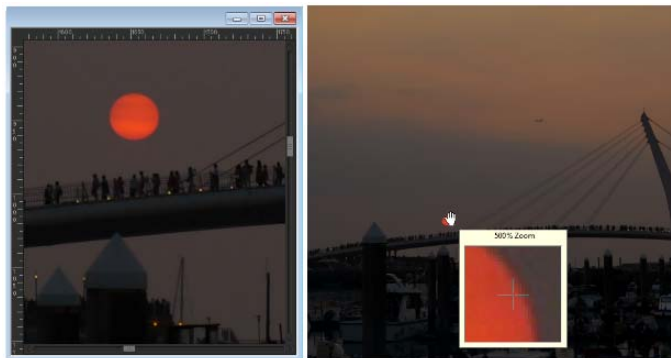

*You can use the **Zoom** tool to magnify your image (left) or you can use the **Magnifier** command to view a specific area without changing the magnification of the image (right).*

## To zoom

Edit workspace

- 1 On the Tools toolbar, choose the **Zoom** tool .
- 2 Click to magnify the area, or right-click to reduce the area.

The magnification changes to a preset percentage that appears in the **Zoom (%)** control on the Tool Options palette.

## You can also

---

Magnify the image by a specified percentage

On the Tool Options palette, type a value in the **Zoom (%)** control.

---

View the image at 100%

Choose **View ▶ Zoom to 100%**, or click the **Zoom to 100%** button  on the Tool Options palette.



By default, when you zoom in or out, the image window automatically resizes to fit the image.



You can also change the magnification when the **Zoom** tool is active by using the scroll-wheel if one is included on your mouse or stylus.

You can also change the magnification of an image by choosing **View ▶ Zoom in** and **View ▶ Zoom out**.

## To magnify an image area

Edit workspace

- 1 Choose **View ▶ Magnifier** to place the cursor in magnifier mode.
- 2 Position the cursor over the image area that you want to magnify. The area under the cursor is displayed at 500%.



To turn off the magnifier mode, choose **View ▶ Magnifier** again.

## To pan around an image

Edit workspace

- 1 On the Tools toolbar, choose the **Pan** tool .
- 2 Drag within the image.

### You can also

---

Pan while using another tool	Hold down the <b>Spacebar</b> , and drag with the other tool.
Pan around an image by using the Overview palette	Drag the preview rectangle on the Overview palette to a new position.



---

## To fit the window to the image

Edit workspace

- Choose **Window ▶ Fit to Image**.



You can also fit the window to the image by clicking the **Fit Window to Image** button  on the Tool Options palette when the **Pan** tool  or **Zoom** tool  is active.

## Cutting, copying, and pasting

You can select an entire image, part of an image, or an entire layer, and cut it or copy it to the Clipboard. You can then paste the Clipboard content into the same image or another image, or into another application, such as an e-mail program or word processor. The basic commands for cutting, copying, and pasting are as follows:

- **Cut** — removes the selected content to the Clipboard and replaces it with the image background color or transparency
- **Copy** — copies the selected content to the Clipboard
- **Copy Merged** — copies a flattened (merged) version of all the layers in a selection to the Clipboard
- **Copy Special** — provides three options for optimizing copied content for subsequent pasting into another application
- **Paste** — pastes cut or copied content from the Clipboard into the same image or another image
- **Clear** — deletes the selected content
- **Empty Clipboard** — erases the data from the Clipboard. Placing data on the Clipboard for cutting and pasting can slow your computer's performance. Emptying the Clipboard can restore the performance speed of your computer. Once applied, this command cannot be undone.

You can cut or copy a selection, layer, or vector object. You can paste the selected content as a new image, a new layer, or a selection.



You can also copy a Corel PaintShop Pro image into other applications, such as word-processing or desktop-publishing applications. For information about exporting Corel PaintShop Pro files to other formats, see “Saving images” on page 64.

### Why does the pasted image look out of proportion?

When you paste data into another image, the data keeps its original pixel dimensions. If one image is much larger or smaller than the other, the pasted content may look out of proportion. After you paste the selection, you can use the Pick tool to scale the pasted content. For more information about using the Pick tool to correct perspective, see “Scaling and transforming photos using the Pick tool” on page 267.

You can also resize the two images to make them a similar size before copying and pasting. For more information, see “Resizing images” on page 221.

### To cut a selection, layer, or vector object

Edit workspace

- 1 Select the area, layer, or object you want to cut.
- 2 Choose **Edit ▶ Cut**.



You can also cut by pressing **Ctrl + X**.

### To copy a selection, layer, or vector object

Edit workspace

- 1 Select the area, layer, or object you want to copy.
- 2 Do one of the following:
  - To copy only the selection or the active layer, choose **Edit ▶ Copy**.
  - To copy all layers of the selected area, choose **Edit ▶ Copy Special ▶ Copy Merged**.



You can also press **Ctrl + C** to copy the active layer, or **Ctrl + Shift + C** to copy merged layers.

## To paste content as a new image

Edit workspace

- Choose **Edit ▶ Paste As New Image**.



You can also paste as a new image by pressing **Ctrl + Shift + V**.

## To paste content as a new layer

Edit workspace

- 1 Select the image in which you want to paste the selection.
- 2 Choose **Edit ▶ Paste As New Layer**.



You can also paste a new layer by pressing **Ctrl + V**, or **Ctrl + L**.

## To paste content as a selection

Edit workspace

- 1 Select the image in which you want to paste a selection.
- 2 On the Layers palette, click the layer in which you want to paste the selection.
- 3 From the **Edit** menu, choose one of the following commands:
  - **Paste As New Selection** — pastes the contents of the Clipboard as a floating selection above the current layer. If the image already contains a floating selection, that selection is defloated.
  - **Paste As Transparent Selection** — lets you remove a specific color from the selection you are pasting. Any pixels in the Clipboard data that exactly match the current background color become transparent. The Clipboard contents are then pasted as a floating selection above the current layer.

- **Paste Into Selection** — resizes the Clipboard contents and pastes them into the current selection



Select the background color on the Materials palette before you paste.



To paste a vector object, choose **Edit ▶ Paste As New Vector Selection**.

## To copy a multilayer image to the Clipboard

Edit workspace

- Choose **Edit ▶ Copy Special ▶ Copy Merged**.

## To empty the Clipboard

Edit workspace

- Choose **Edit ▶ Empty Clipboard**.

## Copying images into other applications

The proliferation of high-resolution digital cameras and scanners has resulted in images with very large file sizes. When copied to the Windows Clipboard, these images consume far more memory than what is required after they are pasted into another application. You can use the Copy Special commands to more efficiently place image data on the Clipboard for pasting into office productivity software, such as word-processing, presentation, and e-mail applications.

## To copy images for use in other applications

Edit workspace

- 1 Choose **Edit ▶ Copy Special**.
- 2 In the **Copy Special** submenu, choose one of the following commands:

- **Copy for Professional Printing** — copies the current image to the Clipboard at 300 dpi
- **Copy for Desktop Printing** — copies the current image to the Clipboard at 200 dpi
- **Copy for Screen or e-mail** — copies the current image to the Clipboard at 96 dpi

**Note:** These three submenu commands all automatically flatten the current image to a single layer and convert the image depth to 8-bit/channel RGB.

- 3 Switch to the application into which you want to paste the image, and press **Ctrl+V**.



If you want a wider range of resizing and file format options for images to be used in other applications, choose **File ▶ Save for Office**. For more information, see “To save images for office applications” on page 68.

## Undoing and redoing actions

You can undo single or multiple actions as you edit an image. For example, you can undo brushstrokes, color adjustments, or effects that you have applied to the image. You can also redo single or multiple actions to reapply commands that you have undone.

You can also revert to the last saved version of the image.

The History palette lets you undo and redo actions selectively, regardless of their sequence.

***Important!** The Undo control does not undo the following actions: renaming files, saving files, opening and closing files, emptying the Clipboard, making changes that are program-wide and not specific to the current image (such as changes to color settings and*





*preferences), or using commands that do not change the image pixels (such as zooming or scrolling).*

## Undo and redo controls on the History palette

You can undo multiple actions, as well as specific actions, by using the History palette. The History palette lists all actions performed on the active image. The most recent action is at the top of the list, and the first action performed is at the bottom of the list. Unlike the Undo and Redo commands, the History palette lets you undo or redo actions selectively, regardless of their sequence.

By default, the History palette lists the 250 most recently executed commands on the active image. You can set the Undo preferences and specify a higher or lower number of commands.

The table below lists the Undo/Redo controls on the History palette.

 <b>Undo to Here</b>	Undoes the selected action and all subsequent actions. Clicking this button is equivalent to clicking an item's eye icon. The undone actions are denoted by a blank box  .
 <b>Redo to Here</b>	Redoes the selected action and all undone actions preceding it. Clicking this button is equivalent to clicking an item's yellow-X eye icon.
 <b>Undo Selected</b>	Undoes a selected action. Clicking this button is equivalent to holding down <b>Ctrl</b> and clicking an item's eye icon. Note: Undoing a selected action may interfere with subsequent actions and produce unintended results.



## Redo Selected

Redoes a selected action. Clicking this button is equivalent to holding down **Ctrl** and clicking an item's red-X eye icon.

---



## Clear Selectively Undone Commands

Converts all selectively undone actions into commands that can no longer be undone or redone. You are prompted to confirm the performance of this action.

---



## Show Non-Undoable Commands

Shows or hides the non-undoable commands. When shown, non-undoable items are grayed out.

---



## Empty Command History

Converts all History palette items into non-undoable commands. You are prompted to confirm the performance of this action.

---

For more information about the History palette, “To undo and redo actions by using the History palette” on page 91.

## To undo an action

Edit workspace

- Choose **Edit ▶ Undo**.

If you want to undo multiple actions, repeat the **Edit ▶ Undo** command.



The **Undo** command undoes multiple actions in the order in which they were performed. To undo actions selectively, you can use the History palette.

If the action cannot be undone, the **Undo** command is unavailable.



You can also undo an action by clicking the **Undo** button  on the Standard toolbar, or by pressing **Ctrl + Z**.

## To redo an action

Edit workspace

- Choose **Edit ▶ Redo**.



The **Redo** command redoes multiple actions in the order in which they were undone. To redo actions selectively, you can use the History palette.

Only actions that have been undone can be redone.



You can also redo an action by clicking the **Redo** button  on the Standard toolbar, or by pressing **Ctrl + Alt + Z**.

## To revert to the last saved version of an image

Edit workspace

- Choose **File ▶ Revert**.

## To undo and redo actions by using the History palette

Edit workspace



- Choose an action on the History palette, and then perform one of the following actions.

To





Do the following

---

Undo an action

Click the **Undo/Redo** button  for the selected action, or click the **Undo to Here** button . The undone actions are denoted by a blank box



Redo an undone action	Click the <b>Undo/Redo</b> button for the selected action, or click the <b>Redo to Here</b> button  . The selected action and all preceding actions are redone and no longer appear as blank icons. Note that selectively undone actions (denoted with a gray X) that precede the action you clicked are not redone. These actions can be redone only with the <b>Redo Selected</b> command.
Selectively undo an action	Hold down <b>Ctrl</b> , and click the <b>Undo/Redo</b> button for the selected action, or click the <b>Undo Selected</b> button  . Selectively undone actions are denoted by a gray X  .
Redo a selectively undone action	Hold down <b>Ctrl</b> , and click the <b>Undo/Redo</b> button for the selected action, or click the <b>Redo Selected</b> button  .

## To set Undo preferences

Edit workspace

- 1 Choose **File ▶ Preferences ▶ General Program Preferences**.
- 2 From the left pane, click **Undo**.
- 3 Make sure that the **Enable the undo system** check box is marked.  
**Note:** This check box must be marked if you want to undo actions in images that are currently open. If the check box is not marked, you cannot undo any actions in an open image after you click **OK** in the Preferences dialog box.
- 4 Mark or unmark the following check boxes:
  - **Limit undo/redo disk usage to n MBytes of storage per open image** — lets you specify the amount of hard disk storage



available for Undo/Redo operations by typing or setting a value in the control. The storage space needed depends on the current image size and the type of operations you're performing. If you have a large amount of unused disk space, you don't need to mark this option.

- **Limit undo/redo to n steps per open image** — lets you modify the default value of 250 steps. Decrease the value in the control if your unused disk space is less than 500 Mbytes.
  - **Enable Fast Redo** — lets you set the Redo command to work at optimal speed. Do not mark this option if you want the Undo command to work at optimal speed.
- 5 Type or set a value in the **Non-undoable steps in the History Palette** control.

This value specifies the number of non-undoable steps (steps that cannot be undone or redone) that are retained after the Undo/Redo limit has been reached. The default value is 10.



Non-undoable steps cannot be undone or redone. However, they can be reapplied to the current image or to other open images, saved to a Quicksript or to a regular PspScript file, or copied to the Clipboard.

## Repeating commands

The Repeat command lets you reapply the previously applied effect or correction without having to re-access the corresponding dialog box.

The last command that can be repeated is always displayed in the Edit menu. If the previous command cannot be repeated, the Repeat command is unavailable.

## To repeat a command

Edit workspace

- Choose **Edit ▶ Repeat**.



You can repeat multiple commands by recording a script and running it on each image. For information on using scripts, see “Scripting basics” on page 705.

You can also repeat a command by holding down **Shift** while selecting any toolbar button or menu item. The last used settings are applied with the repeated command.

## Deleting images

You can delete image files by using the Organizer palette.

### To delete an image

Edit workspace

- Right-click a thumbnail in the Organizer palette, and choose **Delete** from the context menu.

## Files supported by Corel PaintShop Pro

Corel PaintShop Pro supports the file formats listed in the following table. An asterisk (\*) after a format indicates that the file format is supported in the 32-bit version of the application only.

Format	Description	Support
3FR	Hasselblad RAW	Read only
AI	Adobe Illustrator	Read/Write
ARW	Sony RAW	Read only
BMP	Windows Bitmap	Read/Write
CAL	CALS Raster	Read/Write

CGM	Computer Graphics Metafile	Read only
CLP	Windows Clipboard	Read/Write
CMX*	Corel Clipart	Read only
CR2	Canon RAW	Read only
CRW	Canon RAW	Read only
CT	PaintShop Pro graphics	Read/Write
CUR	Windows Cursor	Read only
CUT	Dr. Halo	Read/Write
DCR	Kodak RAW	Read only
DCX	Zsoft Multipage Paintbrush	Read only
DIB	Windows DIB	Read/Write
DNG	Adobe Digital Negative	Read only
DRW*	Micrografx Draw	Read only
EMF	Windows Enhanced Metafile	Read/Write
EPS	Encapsulated PostScript	Read/Write
ERF	Epson RAW	Read only
GEM	Ventura/GEM Drawing	Read only
GIF	Compuserve Graphics Interchange	Read/Write
HDP	HD Photo format	Read/Write
HPGL*, HGL*, HPG*	HP Graphics Language	Read only
IFF	Amiga	Read/Write
IMG	GEM Paint	Read/Write
J2C	JPEG 2000	Read/Write

J2K	JPEG 2000	Read/Write
JIF	JPEG	Read/Write
JP2	JPEG 2000	Read/Write
JPG	JPEG – JFIF Compliant	Read/Write
JPS	Stereo JPEG	Read only
K25	Kodak Digital Camera File	Read only
KDC	Kodak Digital Camera File	Read only
LBM	Deluxe Paint	Read/Write
MAC	MacPaint	Read/Write
MEF	RAW format	Read only
MOS	Leaf RAW Image	Read only
MPO	Multiple Picture Object	Read/Write
MRW	Minolta RAW	Read only
MSP	Microsoft Paint	Read/Write
NEF	Nikon RAW	Read only
NRW	Nikon RAW	Read only
ORF	Olympus RAW	Read only
PBM	Portable Bitmap	Read/Write
PCD*	Kodak Photo CD	Read only
PCT (PICT)	Macintosh PICT	Read/Write
PCX	Zsoft Paintbrush	Read/Write
PDF	Adobe Portable Document File	Read only
PEF	Pentax RAW	Read only
PGM	Portable Graymap	Read/Write

PIC (Lotus)	Lotus PIC	Read only
PIC (PC Paint)	PC Paint	Read/Write
PNG	Portable Network Graphics	Read/Write
PNS	Stereo PNG	Read only
PPM	Portable Pixmap	Read/Write
PS	PostScript	Read only
PSD	Photoshop	Read/Write
PspImage	Corel PaintShop Pro Image	Read/Write
PSP	Animation Shop	Read
RAF	Fuji RAW	Read only
RAS	Sun Raster Image	Read/Write
RAW	RAW Graphics File Format	Read/Write
RIFF	Corel Painter	Read/Write
RLE	Windows or CompuServe RLE	Read/Write
RW2	LUMIX RAW	Read only
SCT	SciTex Continuous Tone	Read/Write
SR2	Sony RAW	Read only
SRF	Sony RAW	Read only
SVG, SVGZ	Scalable Vector Graphics	Read only
TGA	Truevision Targa	Read/Write
TIF	Tagged Image File Format	Read/Write
UFO	Ulead File Object	Read only

WBM, WBMP	Wireless Bitmap	Read/Write
WDP	Windows Media	Read only
WEBP	WebP Image	Read/Write
WMF	Windows Meta File	Read/Write
WPG*	WordPerfect Bitmap/ Vector	Read/Write
X3F	Sigma RAW	Read only

For an updated list of supported camera models and their RAW file formats, go to [www.corel.com/paintshop](http://www.corel.com/paintshop), and click **Tech Specs**.



## Reviewing, organizing, and finding photos

The Manage workspace is a multifaceted digital image management feature that lets you preview, organize, and streamline your photo-editing workflow.

This section presents the following topics:

- Setting up the Manage workspace
- Browsing folders for photos
- Finding images on your computer
- Working with saved searches
- Adding keyword tags to images
- Viewing photos by tags
- Using the calendar to find images
- Finding people in your photos
- Adding location information
- Working with thumbnails in the Manage workspace
- Capturing and applying edits to multiple photos
- Displaying and editing photo information
- Using Quick Review to review photos
- Working with trays

## Setting up the Manage workspace

When you start up Corel PaintShop Pro for the first time, the Manage workspace appears as your main workspace with the following four components: Navigation palette, Preview area, Organizer palette, and the Info palette. For information about each of these palettes, see “The Manage workspace” on page 24.

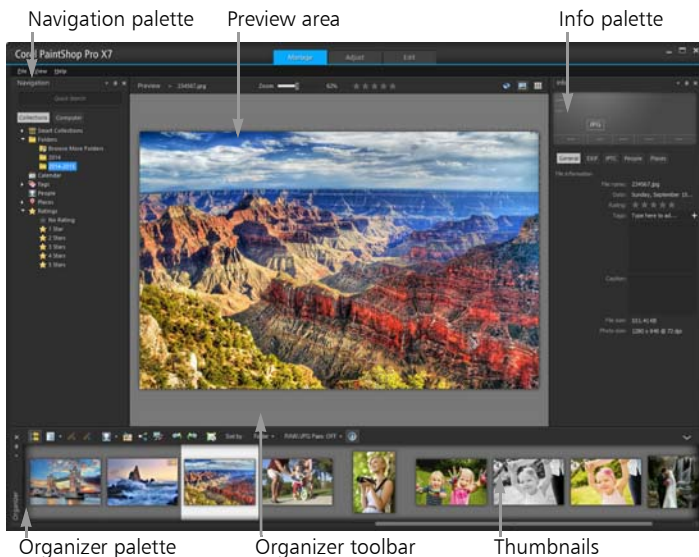

*Manage workspace in Preview mode*

Depending on your specific needs, you can customize the Manage workspace by choosing the Preview, Thumbnail, or Map mode, resizing, moving, or hiding the palettes, and selecting display and file preferences. For more information, see “Setting Manage workspace preferences” on page 681.



Navigation palette

Organizer toolbar

Info palette



Preview area

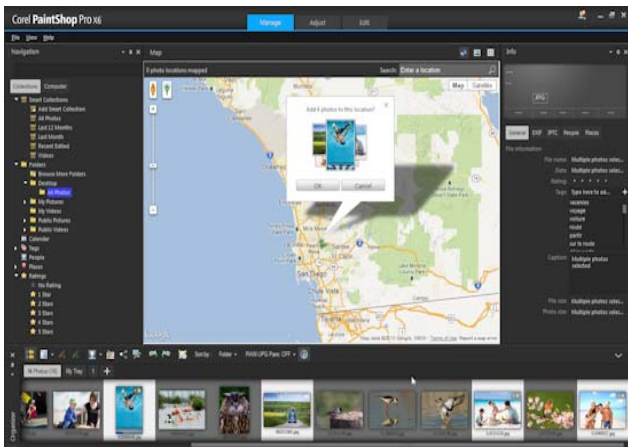

Thumbnails

*Manage workspace in Thumbnail mode*



*Manage workspace in Map mode*

## To switch between Preview, Thumbnail and Map modes

- In the upper-right corner of the Manage workspace, click one of the following buttons:
  - **Preview mode**  — displays a large preview area of a single image
  - **Thumbnail mode**  — expands and locks the Organizer palette content in the preview area
  - **Map mode**  — displays a map where photos can be matched to specific locations

For more information on the geographic tagging of photos, see “Adding location information” on page 118.

## To resize the Manage workspace palettes

### Manage workspace



- 1 Position the pointer over the edge of the palette that you want to resize until the pointer changes to a two-way arrow.
- 2 Drag to enlarge or shrink the panel.



When you customize the Manage workspace, the program remembers the latest layout settings and automatically saves them for your next session.

## To hide or show the Navigation palette and Info palette

### Manage workspace

- In the Organizer palette, click any of the following buttons on the Organizer toolbar:
  - **Show/Hide Navigation**  — shows or hides the Navigation palette
  - **Image Information**  — shows or hides the Info palette



A convenient way to minimize the Organizer palette (or any palette) is to click the **Auto Hide** button  on the palette title bar. For more information, see “To roll up a toolbar or palette” on page 41.

## Browsing folders for photos

You can browse for photos on your computer by using the Collections and Computer tabs in the Navigation palette:

- The **Collections** tab is your library of virtual and physical folders. It offers an easy way to find and search for favorite photos because files that are accessed from the Collections page are imported to the catalog (a type of indexing). This means you can take full advantage of file management features such as tags, captions, and ratings when you want to find and sort photos. You can add or remove folders from the Collections page at any time.
- The **Computer** tab displays a complete list of all folders on your hard drive and desktop. Files that you access from the Computer tab are not imported to the catalog, so you can't find or sort photos by using the file management features such as tags, captions, and ratings. Why use the Computer tab? It is a quick way to access files from a location that you don't want to import to the catalog or don't have time to import at the moment. For example, if you want to access an image in a folder that has a large number of files that you rarely use or if you want to access files in a temporary folder, the Computer tab is a good option.

When you select a folder in the Navigation palette, the photos in this folder appear as thumbnails in the Organizer palette.

For more information, see “Getting photos into Corel PaintShop Pro” on page 60.

You can specify formats and folders to exclude from the cataloging process. For more information, see “Setting Manage workspace preferences” on page 681.

## To view the photos in a folder

### Manage workspace

- 1 In the Navigation palette, click one of the following tabs:
  - **Collections** — displays a custom list of cataloged folders and a list of virtual collections
  - **Computer** — displays a list of all folders and devices on your computer
- 2 Double-click a folder to display the subfolders it contains.
- 3 Click the folder that contains the photos that you want to view.  
The thumbnails of all supported photo files in the selected folder appear in the Organizer palette.



You can also hide the list of subfolders in a folder by clicking the minus sign next to its name.

## To add a folder to the Collections page

### Manage workspace

- 1 In the Navigation palette, click the **Collections** tab.
- 2 In the Folders list, click the **Browse More Folders** button .  
The Browse For Folder dialog box appears.
- 3 Navigate to the folder containing the images you want to add, and then click **OK**.

**Note:** All subfolders in the selected folder are cataloged, so select your folder carefully. Adding your profile folder or a root folder on your computer is not recommended—it can initiate a large amount of cataloging that you might not require.

The folder is added to the Folders list.



You can also create a folder on your computer by clicking the **Make New Folder** button in the Browse for Folder dialog box.

## To remove a folder from the Collections page

Manage workspace

- 1 In the Navigation palette, click the **Collections** tab.
- 2 In the Folders list, right-click the folder that you want to remove.
- 3 Choose **Remove From List**.

Images within the folder retain their file management data (tags, ratings, captions), but removing the folder from the Collections page removes the folder from the catalog, so the photos aren't searchable by their data.

## To view all cataloged photos

Manage workspace

- 1 In the Navigation palette, click the **Collections** tab.
- 2 In the Smart Collections list, click the **All Photos** button .

## Finding images on your computer

When you import photos into Corel PaintShop Pro by navigating to them from the Navigation palette, they are cataloged automatically. Cataloged images can be searched for quickly (real-time filtering) and easily from the Search box. You can do a simple text-based search, use more advanced search options, or use a calendar to search for images associated with a particular date or date range.

When you perform an advanced search, you can save the search rules and results as a Smart Collection.

### To search for images quickly

Manage workspace

- In the Navigation palette, type a search term in the Search box.

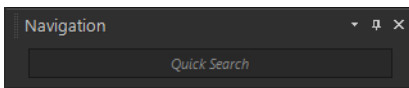

The search results appear in the Organizer palette.

**Note:** Search terms may be filenames (including extensions), names of folders in which images reside (including letters designating drives), tags, caption text, or image metadata (EXIF or IPTC data).



For more information about the tags that you can assign to images, see “Adding keyword tags to images” on page 109. For more information about caption text and image metadata, see “Displaying and editing photo information” on page 132.

### To do an advanced search

Manage workspace

- 1 In the Navigation palette, click the **Collections** tab.

- 2 Double-click **Smart Collections** to open the list, and click **Add Smart Collection**.

The Smart Collection dialog box appears.

- 3 In the Find photos that match drop-list, select one of the following options:
  - **All** — searches for images that match all of the specified rules
  - **Any** — searches for images that match any of the specified rules
- 4 From the first drop-list on the left, select a search option.
- 5 From the next drop-list, select an option to refine the search further.

The options that appear in the drop-list depend on the search option that you chose in the previous drop-list.



- 6 In the text field, type or choose a search term.

**Note:** The search term you type must correspond to the search option that you choose in the first drop-list of the search rule. For example, if you choose **Image date**, modify the month, date, and year displayed, or press the down arrow button and click a date on the calendar that appears. If you choose **Rating**, click the number of stars matching the rating assigned to the image.

- 7 Click **Preview**.

The search results appear in the Organizer palette.

## You can also

Add an additional search rule	Click the <b>Add Rule</b> button  in the upper-right corner of the dialog box.
Remove the last search rule	Click the <b>Remove Rule</b> button  .
Save the search as a Smart Collection	Click <b>Save</b> in the Smart Collection dialog box. In the Save as Smart Collection dialog box, type a name, and click <b>Save</b> . The collection appears in the Smart Collections list.

## Working with saved searches

After you save a custom set of search criteria as a Smart Collection, you can run the search again simply by clicking it on the Collections tab. You can also edit, rename, or delete a saved search.

### To run a saved search

Manage workspace

- 1 In the Navigation palette, click the **Collections** tab.
- 2 Double-click **Smart Collections** to open the list.
- 3 Click the Smart Collection you want to use for your search.

### To edit a saved search

Manage workspace

- 1 In the Navigation palette, click the **Collections** tab.
- 2 Double-click **Smart Collections** to open the list.
- 3 Right-click the Smart Collection, and click **Edit**.

The Smart Collection dialog box appears with the search criteria displayed.

- 4 Change the search parameters, and click **Preview**.  
The search results appear in the Organizer palette.
- 5 Click **Save**.

The Save as Smart Collection dialog box appears, with the search name highlighted in the text field.

- 6 Click **Save**.  
The previous search is overwritten.



To avoid overwriting the previous search, type a new name for the edited search in the text field, and click **Save**.



## To rename a saved search

### Manage workspace

- 1 In the Navigation palette, click the **Collections** tab.
- 2 Double-click **Smart Collections** to open the list.
- 3 Right-click the Smart Collection, and click **Rename**.

The Rename Smart Collection dialog box appears with the search name highlighted.

- 4 Type a new name, and click **Save**.

## To delete a saved search

### Manage workspace

- 1 In the Navigation palette, click the **Collections** tab.
- 2 Double-click **Smart Collections** to open the list.
- 3 Right-click the Smart Collection, and click **Delete**.

## Adding keyword tags to images

Keyword tags let you assign descriptive, natural-language terms to images. By creating tags such as “family,” “children,” or “birthday,” you can identify specific photos, and then simply click a tag from the list to view thumbnails of photos associated with the tag. The tags that you create are stored in a tags catalog accessible from the Navigation palette. You can create and assign as many tags as you like to an image.

## To add a keyword tag to the tags catalog

### Manage workspace

- 1 In the Navigation palette, click the **Collections** tab.
- 2 Double-click **Tags** to open the list.
- 3 In the Tags list, click the **Add Tags** button .

The Add Tag dialog box appears.

- 4 Type the tag text, and click **OK**.  
The new tag appears in the Tags list.

## To delete a keyword tag from the tags catalog

### Manage workspace

- 1 In the Navigation palette, click the **Collections** tab.
- 2 Double-click **Tags** to open the list.
- 3 Right-click a tag, and click **Delete**.

## To assign a keyword tag to one or more images

### Manage workspace

- 1 In the Navigation palette, click the **Collections** tab.
- 2 Double-click **Tags** to open the list.
- 3 In the Organizer palette, select one or more thumbnails of the images that you want to tag.
- 4 Drag the thumbnails onto a tag in the Tags list.



You can also assign one or more tags to the selected thumbnails by typing the text in the **Tags** box on the General page of the Info palette, and clicking the **Add Tag** button  to the right of the text field.

## To remove keyword tags from one or more images

### Manage workspace

- 1 In the Organizer palette, select one or more thumbnails.
- 2 In the Info palette, click the **General** tab to view the tag information.
- 3 In the list that appears below the **Tags** box, click one or more tags that you want to remove, and click the **Delete Tag** button  that appears to the right of the tag name.



If the Info palette is not displayed, click the **Image information** button  on the Organizer toolbar.

## Viewing photos by tags

After you assign a tag to an image, you can find the image simply by clicking on the tag.

### To display photos by tags

*Manage workspace*

- 1 In the Navigation palette, click the **Collections** tab.
- 2 Double-click **Tags** to open the list.
- 3 Click a tag.

Photos associated with the tag display as thumbnails in the Organizer palette.



You can also type a tag name into the Search box at the top of the Navigation palette.

You can also display photos that have no tags by clicking the **No Tags** button  in the Tags list.

## Using the calendar to find images

The Calendar Search lets you find photos according to the date they were taken. You can search by a specific date or select a date range. The image creation dates are highlighted on the calendar.

Note: When you edit and save a photo, the modification date is also captured in the Calendar Search.

## To find images by using the calendar





### Manage workspace

1 In the Navigation palette, click the **Collections** tab.

2 Click the **Calendar** button .

The Calendar Search dialog box appears. Dates shown in red indicate images created on those dates.

3 Choose one of the following options:

- For photos taken today, click the **Today** button .
- For a specific date and month, click the **Previous (Year/Month)**   and **Next (Month/Year)**   buttons, and select a date.
- For a date range, use the **Previous** and **Next** buttons to select the month and year, hold down **Shift**, click the first date in the range, and then click the last date in the range.
- For multiple dates not in sequence, use the **Previous** and **Next** buttons to select the month and year, hold down **Ctrl**, and click the dates.

When you click a date or a range, the Organizer palette displays thumbnails of the photos that match the date criteria.

4 Click **Close** to close the Calendar Search dialog box.

## Finding people in your photos

Sorting photos according to the people in them is a great way to organize your photos. There are two ways to tag people in your photos:

- **Face recognition** — analyzes facial characteristics and uses reference photos to build a list of possible matches. People with similar characteristics are sorted into groups, making it easier for you to look through your photos and identify people. You can move photos between groups until all photos of the same person

are in one group, and then type a name for the group to automatically tag all photos in the group with the name of that person.

- **Manual tagging** — lets you tag people manually in your photos. You can add multiple tags to the same photo, or tag objects or other areas of the photo with the names of people, to make sure that they are notified when the photo is uploaded.

## Importing your friends list from sharing sites

You can import your friends list from sharing sites, such as Facebook and Flickr, and link the names in your photos with names from the sharing sites. When the local tags in Corel PaintShop Pro are linked with the sharing site tags, the people who appear in the photos will be automatically notified when you upload the photos to the site. No need to tag them again!

## To sort photos by people

Manage workspace

- 1 In the Navigation palette, click the **Collections** tab.
- 2 Navigate to the folder containing the images that you want to sort.
- 3 In the Organizer palette, click the **Find People** button  on the Organizer toolbar, and choose one of the following options:
  - Scan selected photos
  - Scan current folder
  - Scan subfolders

If no photos are selected, face recognition is applied to the whole folder.

After you run face recognition, the photos are sorted into groups of people and placed in a folder called Unnamed.

- If the Manage workspace is not in Thumbnail mode, click the **Thumbnail Mode** button  in the upper-right corner of the Manage workspace to view the groups.

The group containing the most photos is listed first. Within each group, the most recent photos are displayed first. People that appear in only one photo are grouped together in a group called Single Face Group.

- Click in the title bar of a group and type a name for the group. All photos in the group are tagged with the name.



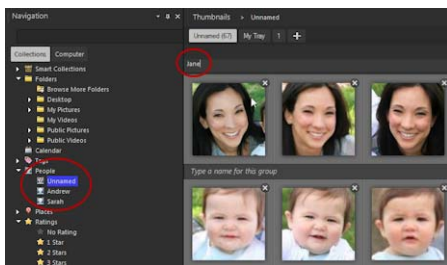

If you want to increase the accuracy of the face recognition results, you can select 10 clear photos of the same person and run face recognition on those 10 photos first. These reference photos will increase the accuracy of future facial matches for that person.



*After you type a name for a group, the group is moved from the Unnamed folder to a new, named folder in the Navigation palette.*

## You can also

---

Toggle view between face and full photo	Click the <b>View Face</b>  and <b>View Full Image</b>  buttons on the group tab.
Rename a group	In the Navigation palette, right-click the folder name, and choose <b>Rename Group</b> .
Delete a group	In the Navigation palette, right-click the folder name, and choose <b>Delete Group</b> . The group name is deleted, the tags are removed from the photos, and the photos are moved back to the Unnamed folder.
Move a photo from one group to another	Right-click the photo, choose <b>Move Person</b> , and choose a name from the list. You can also drag a photo to another folder in the Navigation palette.
Remove a photo from a group and create a new folder for it	Right-click the photo, choose <b>Move to New Person</b> , and type a name for the new group. The photo is removed from the current group and placed in the new group.
Move a photo from a named folder back to the Unnamed folder	Right-click the photo, and choose <b>Remove Person from Group</b> . You can also drag a photo from a named group to the Unnamed folder in the Navigation palette.
Move a face to the Ignored Bin	Right-click the photo, and click <b>Ignore Person</b> . In the Unnamed group, you can also click the <b>Delete</b> button in the upper-right corner of the photo.

---

## You can also

---

Exclude a face from face recognition Select the Unnamed folder in the Navigation palette, and click **Ignored**. Select the photo, and click **Do Not Detect**.

---

Link a group tag to a contact from a sharing site Click the icon for the sharing site in the **Link tags** area, and choose a name from the list. **Note:** The friends list from the site must be imported first (see “To import a friends list from a sharing site” on page 116).

---

## To import a friends list from a sharing site

### Manage workspace

- 1 In the Navigation palette, click the **Collections** tab, and click a name in the People list.
- 2 In the **Link tags** area, click the icon that corresponds to the sharing site from which you want to import your friends list.

If you are not currently logged into the sharing site, you’ll be asked to log in and allow Corel PaintShop Pro to access the site.

## To tag people manually

### Manage workspace

- 1 In Preview mode, select the photo that you want to tag.
- 2 Under the People tab in the Info palette, click **Tag Person**.  
A square frame appears in the center of the photo in the preview window.
- 3 Click in the **Who is this?** box.  
A name picker appears, showing a local name list, as well as the contacts from sharing sites that you have imported.
- 4 Do one of the following:



- Type a name in the box, and click **Add New Person**.
- Choose a name from the local list of names.
- Click a sharing site tab, and choose a name from the list.

## You can also

---

Create a frame with a different size, Drag in the preview area shape, or location

---

Move the frame

Drag the frame in the preview area to the desired location.

---

Resize the frame

Point to the edge or corner of the frame. When the pointer changes to a two-way arrow, drag to resize the frame.

---

Edit the tag

Point to the frame, click the button  next to the name, and choose a new name from the picker.

---

Remove the tag

Point to the frame, and click the **Delete** button  in the upper-right corner of the frame. If the tag is part of a face group, the photo is removed from the group.

---

View all tags in a photo

Hover over areas of the photo to see existing frames. In addition, all tags for the selected photo are listed in the Names box under the People tab in the Info palette.

---

Link a local tag to one or more social tags

In the name picker, click a name in the local list, and then click the corresponding name in one or more of the sharing site lists. Click **Save** to tag the photo and link the local and sharing site name tags.

---

## You can also

---

Update the list of social contacts      In the name picker, click **Update Contacts**.

---

## Adding location information

There are several ways to add information about the locations where your photos were taken.

- **Automatically** — If your camera or smartphone has a GPS, it automatically records the latitude and longitude of each photo you take, and the information is imported with the photo.
- **Manually** — You can add location information manually in Map mode by searching for a specific location or choosing a location interactively on the map.
- **By copying location info from other photos** — You can copy and paste location information from one photo to another. This is useful, for example, if you use your smartphone to take a photo and then copy the location information to multiple photos taken with your camera at the same location.
- **From Facebook check-in points** — If you use the Facebook check-in function, you can match your check-in locations to your photos.
- **From a GPS device** — If your camera does not record location data, you can use a separate GPS device or a smartphone app, synchronized with your camera time zone, to keep track of the latitude and longitude as you travel and take photos. Then, you can import the data from the GPS device by importing a KML file. KML is a standard format for storing geographic data that can be displayed in Google Maps and other applications.

After you tag your photos with location information, you can create an interactive slideshow and share it online. For more information, see “Creating Share My Trip projects” on page 754.

## Viewing location information

After you assign a location to a photo, a location marker is displayed on the map in Map mode and added to the thumbnail of the tagged photo. Location information also appears in the Navigation and Info palettes.

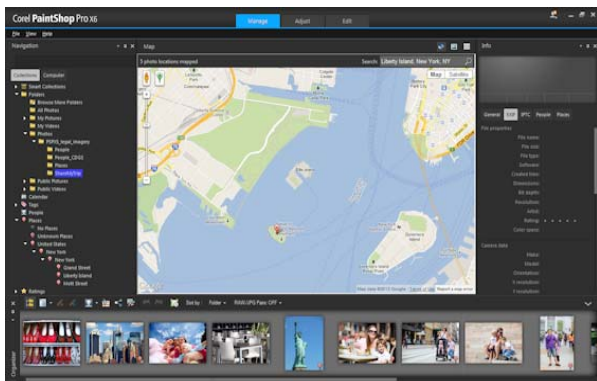

*In Map mode, you can view location information on an interactive map (center), the Navigation palette (left), and the Info palette (right).*

- **Navigation palette** — Tagged photos are organized by location in the Places folder, following the hierarchy of country, district, city, and road. Photos that contain location information that cannot be matched to the map are listed in the Unknown Places folder. You can tag these photos either manually or by importing and matching location data. After the photos are tagged, they are moved to a folder that corresponds to their location.

- **Info palette** — Location information appears under the Places tab. Location markers can be viewed on a map, and the names of the corresponding locations are listed in the Location box below. The Info palette also displays editable latitude and longitude information.

Map mode is integrated with Google Maps, and it offers a variety of viewing options, such as zooming in and out, or using Google Street View. For more information about the available options, refer to the Google Maps Help.

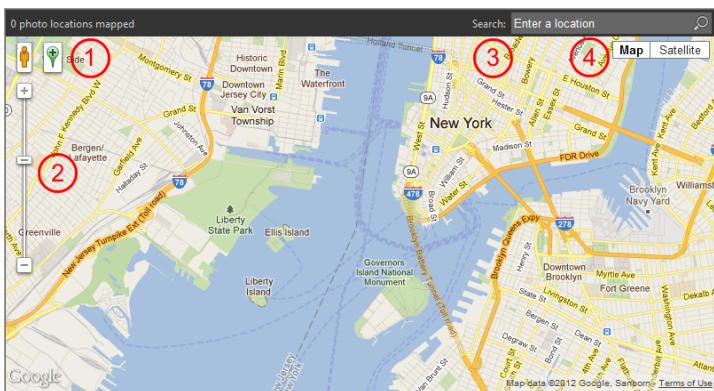

*Map mode offers all standard Google Maps features. You can 1) activate Street View by dragging the yellow pegman to the map, 2) zoom in or out by dragging the slider, 3) search for a location, and 4) choose a map view.*

You can also sort photos by location, or delete location information from a photo.

**Privacy Note:** Sharing sites use different methods to disable location information — some sites delete the information, some sites hide the information (but it's still there). You can use Corel PaintShop Pro to

delete location information before you upload photos that may have home, school, or work locations that you don't want to make public.

## To switch to Map mode

Manage workspace

- Click the **Map mode** button  in the upper-right corner of the Manage workspace.

### You can also

---

Choose a map view

Click the **Map** or **Satellite** button in the upper-right corner of the Map area, and choose the options you want.



---

Zoom in or out

Drag the **Zoom** slider up or down. Higher zoom levels reveal greater map detail, as well as any additional location markers that may have been grouped together as a single marker at lower zoom levels.

---

Use Google Street View

Drag the yellow pegman  to a location on the map. To exit Google Street View, click the **Close** button .



If the selected photos already contain location information, the map zoom level is adjusted to fit all existing location markers. If no photos are selected, the map displays all locations associated with the current folder.

If a single photo is selected, and the photo contains direction information, the map shows Google Street View by default.

For more information about the different modes of the Manage workspace, see “Setting up the Manage workspace” on page 100.



You can click a location marker on the map to display information about the photos tagged at that location.

## To add location information manually

### Manage workspace

1 If the workspace is not in Map mode, click the **Map mode** button  in the upper-right corner of the Manage workspace.

2 In the Organizer palette, select all photos that you want to tag with a specific location.

If no photos are selected, the location tag will be added to all photos in the current folder.

3 Do one of the following:

- Start typing the name of the location in the search box, and choose a location from the list that appears.
- Click the **Add location** button , and then click directly on the map to tag the selected photos with the chosen location.
- Type latitude and longitude in the boxes under the Places tab in the Info palette. This option is available in Map, Thumbnail, and Preview modes.

A location marker is added to the map, and a marker also appears in the lower-right corner of each tagged photo.



If more than twenty photos are selected, a confirmation dialog box appears. Click **Yes** to tag all selected photos.

## To copy and paste location information

### Manage workspace

1 Select the photo from which you want to copy location information.

2 In the Info palette, click the **Places** tab, and click **Copy**.

- 3 Select one or more photos to which you want to add the copied location information.
- 4 In the Info palette, click **Paste**.  
Location tags are added to the photos.

## To import location information

- 1 Select the photos for which you want to import location information.
- 2 Click the **Import Location Info** button .
- 3 In the Add Location Info dialog box, enable one of the following options:
  - **Import location info from your Facebook check-in list.**
  - **Import location data from a GPS tracker (KML file).**If you choose to import data from a GPS tracker, click **Import**, and locate the KML file that you want to use. Choose an option from the Time Zone list.
- 4 Click **Add**.



If the selected photos already contain location information, a dialog box appears prompting you to choose whether to override the existing information and replace it with the imported data.

If the KML data does not match the photos, a warning appears. When location information is added to RAW files, the information is stored in the application only, and the files are not altered.



You can click the **Details** tab to view a map and other details about the selected location.

## To sort photos by location

### Manage workspace

- 1 In Thumbnail mode, click the **Sort by** drop-list on the Organizer toolbar.
- 2 Click the **Place** sorting option.  
The selected photos are sorted by country, district, city, and road, with the most recent location listed first within each group.

## To delete location information

### Manage workspace

- 1 Select the photos from which you want to delete the location tags.
- 2 In the Info palette, click the **Places** tab, and click **Delete**.  
The location information is removed from the selected photos.

## Working with thumbnails in the Manage workspace

The Manage workspace makes it easy for you to preview and organize photos by using thumbnails.

For a larger view of photos, use Preview mode, zoom in and out on thumbnails, or use Quick Review to view photos in full-screen mode. You can sort thumbnails by criteria such as name, rating, or date. You can also rotate photos by using thumbnails, or delete and rename the files.

For multi-image shooting, you can use Auto Group and RAW/JPG Pairs to group and view thumbnails according to bracketing settings or JPEG+RAW file pairs.

Thumbnails let you edit multiple photos by using Capture editing and Apply editing. For more information, see “Capturing and applying edits to multiple photos” on page 129.



In addition, you can select one or more RAW file thumbnails to convert the files to another format. For more information, see “Converting RAW photos to another file format” on page 146.

## To preview an image in the Manage workspace

- In the Organizer palette, click a thumbnail.

If you are not in Preview mode, click the **Preview mode** button  in the upper-right corner of the application window.

The photo is displayed in the Preview area.

## You can also

---

Display the previous or the next image in the Preview area by using the keyboard

Press the **Left arrow** or the **Right arrow** keys.

---

Preview an image in full-screen mode

Click **View ▶ Full Screen Preview**, or double-click a thumbnail to open Quick Review. For more information, see “Using Quick Review to review photos” on page 135.

---

## To zoom in or out on thumbnails

- 1 If the Manage workspace is not in Thumbnail mode, click the **Thumbnail mode** button  in the upper-right corner of the Manage workspace.
- 2 On the Organizer toolbar, move the **Zoom** slider to the left to zoom out, or to the right to zoom in.



The Zoom slider is not available when the Manage workspace is in Preview mode.

## To sort thumbnails

### Manage workspace

- 1 On the Organizer toolbar, click the **Sort by** drop-list.
- 2 Choose a sorting option.
- 3 Choose one of the following options:
  - **Date Created - Newest** — sorts thumbnails, from newest to oldest, by the date on which the photo was taken
  - **Date Created - Oldest** — sorts thumbnails, from oldest to newest, by the date on which the photo was taken
  - **Date Modified** — sorts thumbnails by the date on which the image was last modified
  - **Folder** — sorts thumbnails alphabetically by folder name
  - **Filename** — sorts thumbnails alphabetically by filename (image name)
  - **Rating** — sorts thumbnails by image rating
  - **File Format** — sorts thumbnails alphabetically by filename extension (for example, .psp image, .jpg, or .tif)
  - **File Size** — sorts thumbnails by the file size (in kilobytes) from smallest to largest
  - **Place** — sorts thumbnails by the location that is associated with the photo

## To group thumbnails according to shooting time

- On the Organizer toolbar, click **Auto Group** and set a time interval. Photos that have been captured within the time interval are displayed as sets (dividers appear between sets).

## To control how RAW and JPEG pairs are displayed

- 1 On the Organizer toolbar, click the **RAW/JPG Pairs** button, and choose one of the following options:

- **ON - Show JPG Versions** — shows the JPEG versions as thumbnails and hides the RAW versions
- **ON - Show RAW Versions** — shows the RAW versions as thumbnails and hides the JPEG versions
- **OFF** — shows thumbnails for both the RAW and JPEG versions of the files.



If you delete a thumbnail when the RAW/JPG Pairs option is turned on, both versions of the files are sent to the Recycle Bin.

## To select more than one thumbnail

Manage workspace

- Do one of the following:
  - To select adjacent thumbnails, hold down **Shift**, and click the first and the last thumbnail in the sequence of thumbnails.
  - To select nonadjacent thumbnails, hold down **Ctrl**, and click the thumbnails.

## To rotate one or more images in the Organizer palette

Manage workspace

- 1 Select one or more thumbnails.
- 2 On the Organizer toolbar, click one of the following buttons:
  - **Rotate Right** — rotates thumbnails 90 degrees clockwise
  - **Rotate Left** — rotates thumbnails 90 degrees counterclockwise



You can also right-click a thumbnail and choose **Rotate Right** or **Rotate Left** from the context menu.

## To delete one or more photos in the Manage workspace

- 1 Select one or more thumbnails, and press **Delete**.

The Delete File dialog box or Delete Multiple Items dialog box appears.

- 2 Click **Yes** to send the images to the Recycle Bin.



You can also delete photos by selecting thumbnails, right-clicking a selected thumbnail, and clicking **Delete** in the context menu.

## To rename a file in the Manage workspace

- 1 Right-click the thumbnail of the file that you want to rename and choose **Rename**.
- 2 In the Rename File dialog box, type the new filename, and click **OK**.

## To open one or more images for quick touch-up

Manage workspace

- Select one or more thumbnails, and click the **Adjust** tab.

The images open in the Adjust workspace.



The Organizer palette is available in the Adjust workspace, so you can access other photos.



You can also start the Adjust workspace by right-clicking one or more selected thumbnails and choosing **Adjust Photo**.

## To open one or more images for advanced editing

Manage workspace

- Select one or more thumbnails, and click the **Edit** tab.

The images open in the Edit workspace.



You can also start the Edit workspace by right-clicking one or more selected thumbnails and clicking **Edit Photo** in the context menu.

## Capturing and applying edits to multiple photos

In the Manage workspace, you can copy the edits you make to one photo and apply them to as many photos as you want. For example, you can easily apply a lighting correction to multiple photos, or apply the same border and resizing options to a set of photos that you're preparing for a website.

After you edit a photo in the Adjust or Edit workspace, a small editing icon appears on the photo's thumbnail. When you return to the Manage workspace, you can access the Capture editing and Apply editing commands to copy the changes to other photos.

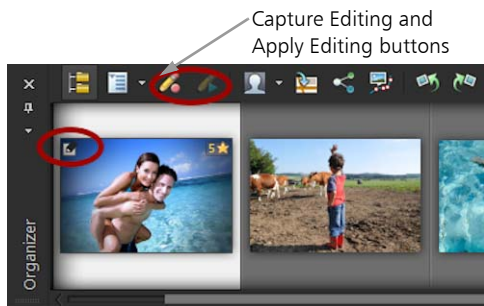

*An icon in the lower-left corner of a thumbnail indicates that the edits to the photo can be copied and applied to other photos.*

You can capture and apply edits to most file types, but edits to RAW files can be applied only to other RAW files. You can undo the edits you apply to one or more photos.

## To capture edits

### Manage workspace

- 1 After editing an image in the Adjust workspace, Edit workspace, or Camera RAW Lab, save the changes, and return to the Manage workspace.
- 2 Select the thumbnail of the photo that you edited.  
A pencil icon or RAW icon appears in the upper-left corner of the thumbnail to indicate that the image has been edited.
- 3 Click the **Capture Editing**  button on the Organizer toolbar.



You can capture the edits of both open or closed files for the current session only. When you close the program, all captured edits are automatically deleted.



You can also capture the edits by right-clicking the selected thumbnail and choosing **Capture Editing**.

## To apply captured edits

### Manage workspace

- 1 In the Organizer palette, select one or more thumbnails.
- 2 Click the **Apply Editing**  button on the Organizer toolbar.
- 3 Click **OK** in the Batch Progress dialog box.  
For RAW files, the saved settings from the Camera RAW Lab dialog box are applied.



When you close the program, all captured edits are automatically cleared.



You can also apply the captured edits by right-clicking the selected thumbnails and choosing **Apply Editing**.

## To undo Apply Editing

- 1 In the Organizer palette, select one or more thumbnails.
- 2 Right-click a selected thumbnail, and choose **Revert Current Editing** from the context menu.



You can also undo the editing to multiple photos by selecting the thumbnails of the edited photos, right-clicking a selected thumbnail, and choosing **Revert All Editing** from the context menu.

## Displaying and editing photo information









The Info palette in the Manage workspace lets you view, add, and edit information about your photos, such as filename, size, and creation date, as well as EXIF and IPTC metadata. You can also add tags and captions, and apply star ratings to photos. Adding and updating photo information makes it easier to organize and search for your photos. For example, you can search by caption text.

- For more information about adding keyword tags, see “Adding keyword tags to images” on page 109.
- For more information about adding people tags, see “Finding people in your photos” on page 112.
- For more information about adding location tags, see “Adding location information” on page 118.

At the top of the Info palette there is a camera-style display that helps you quickly review the camera settings that were used for the selected photo.



### White Balance Symbols

 Custom	 Flash
 Daylight	 Overcast
 Fluorescent	 Shade
 Tungsten	 Partial metering



## White Balance Symbols

---



Auto-white balance

---

## Metering Symbols

---



Custom metering



Spot metering

---



Averaged metering



Multi-spot metering

---



Center-weighted metering



Pattern metering

---

## To display or hide the Info palette

Manage workspace

- On the Organizer toolbar, click the **Image Information** button . The Info palette is open by default but you can hide or display it depending on how much screen space you need.

## To assign a rating to one or more images

Manage workspace

- 1 Select one or more thumbnails.
- 2 In the Info palette, click a star, starting from left to right, to set a rating. For example, if you want to assign a five-star rating, click the right-most star and all stars will be selected.

## You can also

---

Assign a rating by using the context menu Right-click one or more selected thumbnails, choose **Set Rating**, and then click the number of stars that you want to assign.

---

## You can also

---

Assign a rating by using keyboard shortcuts

Select one or more thumbnails, and press **Ctrl** + the number of stars you want to assign. For example, if you want to assign one star, press **Ctrl** + **1**.

---

## To remove the rating of an image

Manage workspace

- Right-click a thumbnail, choose **Set Rating**, and click the number of stars that are currently assigned to the image. For example, to remove the rating of a three-star image, you would choose **Set Rating** ▶ \* \* \*.

## To add a caption to one or more images

Manage workspace

- 1 Select one or more thumbnails.
- 2 In the Info palette, click the **General** tab, and type text in the Caption box.

## To delete a caption from one or more images

Manage workspace

- 1 Select one or more thumbnails that have the same caption text.
- 2 In the Info palette, click the **General** tab.
- 3 Highlight the text you want to delete in the **Caption** box.
- 4 Press **Delete**.

## To view advanced image information

Manage workspace

- In the Info palette, click the **EXIF** or **IPTC** tab.  
The EXIF or IPTC data for the image appears.

**Note:** You can edit only the EXIF or IPTC data that have entry fields.









## Using Quick Review to review photos



You can use Quick Review to review images in full-screen mode. For example, after downloading photos from your camera, you can use Quick Review to quickly review all photos, delete the ones you don't want, rotate photos, and apply star ratings.

### To review images in full-screen mode

Manage workspace

- 1 In the Organizer palette, double-click a thumbnail in the folder or tray that you want to review.  
The Quick Review window opens.
- 2 Perform a task from the following table.

To	Do the following
View the next photo	Click the <b>Next Image</b> button  .
View the previous photo	Click the <b>Previous Image</b> button  .
Open the photo in the Edit workspace	Click the <b>Edit Photo</b> button  .
Apply a star rating	Click a star below the photo, starting from left to right, to set a rating.
Change the Zoom level	Drag the Zoom slider, click the <b>Zoom In</b>  or <b>Zoom Out</b>  buttons, or click the <b>Zoom to 100%</b> button  or the <b>Fit to Window</b> button  .
Delete a photo	Click the <b>Delete</b> button  .

To	Do the following
Rotate a photo	Click the <b>Rotate Right</b> button  or the <b>Rotate Left</b> button  .
Exit Quick Review	Click the <b>Exit</b> button  or press <b>Esc</b> .



You can also use the mouse wheel to change the Zoom level.

## Working with trays

You can use trays to gather images from various folders. The images remain in their original location, but are referenced in the tray and can be accessed by clicking a thumbnail.

You can add, remove, and rename trays to suit your workflow. For instance, you can create a tray for images you want to edit, use for a project, print, or e-mail. Trays are created in the Organizer palette.

The default tray automatically displays the photos from the folder or collection that you currently have selected in the Navigation palette. A custom tray, called My Tray, is a blank tray that is created automatically.

### To add a tray

Manage workspace

- 1 In the Organizer palette, click the **More Options** button  on the Organizer toolbar, and click **Add Tray**.
- 2 Type a name for the new tray in the **Name** field, and click **OK**.

### To rename a tray

Manage workspace

- 1 In the Organizer palette, select the tray that you want to rename.

- 2 Click the **More Options** button  on the Organizer toolbar, and click **Rename Tray**.
- 3 Type a new name for the tray in the **Name** field, and click **OK**.

## To remove a tray

Manage workspace

- 1 In the Organizer palette, select the tray that you want to remove.  
**Note:** Removing a tray does not delete the photos in the tray.
- 2 Click the **More Options** button  on the Organizer toolbar, and click **Remove Tray**.



The default tray, “My Tray,” cannot be removed.

## To add photos to a tray

Manage workspace

- 1 In the Organizer palette, select the thumbnails of the photos that you want to add to the tray.
- 2 Right-click a selected thumbnail and click **Add to Tray**.

The photos are added to My Tray.



To add photos to a custom tray, select the photo thumbnails, and drag them to the custom tray tab in the Organizer palette.

## To remove photos from a tray

Manage workspace

- 1 In the Organizer palette, click a tray.
- 2 Select the photos that you want to remove.
- 3 Press **Delete**.

## To save your tray content to a folder

- 1 In the Navigation palette, click the **Collections** tab.
- 2 Click **Browse More Folders**, navigate to the location you want, and click **Make New Folder**.
- 3 Type a name for the folder, and click **OK**.
- 4 In the Organizer palette, select all the photos in a tray (you can use **Ctrl + A**).
- 5 Drag the photos to the new folder.

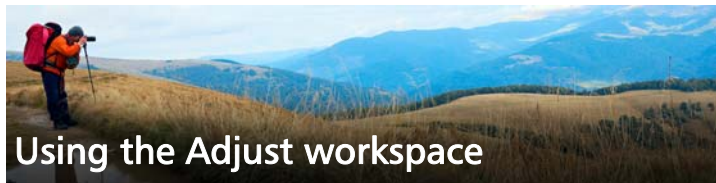

Taking lots of photos with your digital camera is fun and easy. Sometimes, though, the effort required to review them all, let alone edit them, can be laborious. The Adjust workspace can make this task enjoyable. You can perform basic corrections, such as cropping, straightening, color correcting, and removing blemishes and red-eye. You can even apply star ratings and delete photos. This rapid-edit mode lets you quickly complete the first cut of photos before doing more detailed work on a select few.

### **Why use the Adjust workspace?**

The Adjust workspace provides quick access to the most commonly used tools and features of Corel PaintShop Pro — you have the controls right in front of you.

If you prefer to work in the advanced editing mode and have access to the application's entire range of tools and features, you can simply click the Edit tab at the top of the application window to open the Edit workspace. The most recently displayed Adjust workspace photo becomes the active image in the next workspace.

This section presents the following topics:

- Opening the Adjust workspace
- Working in the Adjust workspace
- Tools and features in the Adjust workspace

## Opening the Adjust workspace

You can open the Adjust workspace from the Manage workspace or the Edit workspace.

### To open the Adjust workspace

- Click the **Adjust** tab at the top of the application window.  
The active image appears in the Adjust workspace.

## Working in the Adjust workspace

The Adjust workspace lets you edit photos, one at a time. Your changes are applied each time you click a new tool or feature. You can undo the changes, the same way you would in other workspaces. After you finish editing a photo, you can easily move to the next photo by clicking a thumbnail in the Organizer palette. You have the option to save each time you click another photo or you can choose to save automatically by enabling Autosave when you are prompted.

### To edit or adjust photos in the Adjust workspace

- 1 In the Adjust palette, do one of the following:
  - Click a tool, and adjust the controls to edit the photo. The edits are applied when you click the **Apply** button or when you click another tool or adjustment option.
  - Click the name of the adjustment feature you want to use. The adjustment controls display. The changes are applied when you click another feature.

### To undo changes in the Adjust workspace

- Do one of the following:
  - Click the **Undo** button  on the toolbar.



- Click the **Reset** button at the bottom of the Adjust pane to undo all changes.

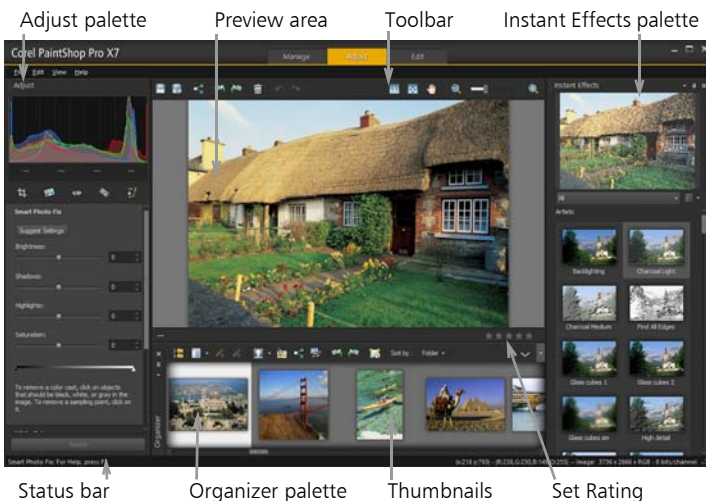

*A photo displayed in the Adjust workspace*

## Tools and features in the Adjust workspace

The table below provides a list of the features available in the Adjust workspace and links to help you find more information.

Tools	Where to find more information
Crop tool	"Cropping images" on page 156
Straighten tool	"Straightening images" on page 162
Red Eye tool	"To remove red-eye quickly" on page 230
Makeover tool	"Applying cosmetic changes" on page 233
Clone Brush	"Removing flaws and objects" on page 240

## Tools

## Where to find more information

---

### Adjustment features

Smart Photo Fix	"Making basic photo corrections automatically" on page 166
White Balance	"Adjusting white balance" on page 182
Brightness/Contrast	"Adjusting brightness, contrast, and clarity" on page 186
Fill Light/Clarity	"Adjusting brightness, contrast, and clarity" on page 186
Vibrancy	"Adjusting hue and saturation" on page 198
Local Tone Mapping	"Adjusting brightness, contrast, and clarity" on page 186
High Pass Sharpen	"Sharpening images" on page 217
Digital Noise Removal	"Removing digital noise" on page 173

---

### General commands and shared features

Saving	"Saving images" on page 64
Rotating	"Rotating images" on page 154
Undoing and redoing	"Undoing and redoing actions" on page 88
Deleting	"Deleting images" on page 94
Viewing and zooming	"Zooming and panning" on page 81
Setting ratings	"To assign a rating to one or more images" on page 133
Organizer palette	"The Adjust workspace" on page 26
Instant Effects palette	"To choose an effect from the Instant Effects palette" on page 418

---



Most DSLR cameras give you the option to take photos in RAW mode. RAW mode records more image data than a typical JPEG. The RAW image data itself remains uncompromised and uncompressed, making it similar to a photo negative that you can print as you like. The Camera RAW Lab in Corel PaintShop Pro acts like a digital darkroom and lets you apply a personal touch to your RAW files.

After processing a RAW image, you can leave it as a read-only RAW file, or export it to a JPEG, GIF, or PNG file so you can edit it. You can also read and save changes to XMP files.

This section presents the following topics:

- Supported RAW file formats
- Using the Camera RAW Lab
- Applying edits to multiple RAW photos
- Converting RAW photos to another file format
- Working with XMP files

## Supported RAW file formats

Camera RAW Lab works with common RAW formats from the major camera manufacturers. You can find an updated list in the Corel Knowledgebase.

## To find supported RAW file formats

- 1 Go to [www.corel.com/knowledgebase](http://www.corel.com/knowledgebase).
- 2 In **Which product?** list, choose **PaintShop**.
- 3 In the **Search using keywords** box, type **X7 RAW**.
- 4 Click the **Search** button.

A list of related articles display.

## Using the Camera RAW Lab

The Camera RAW Lab lets you develop a RAW image by saving a variety of processing settings. After processing a RAW image, you can leave it as a read-only RAW file, or open it in the Edit workspace and save it to a different file format, such as JPEG, GIF, or PNG.

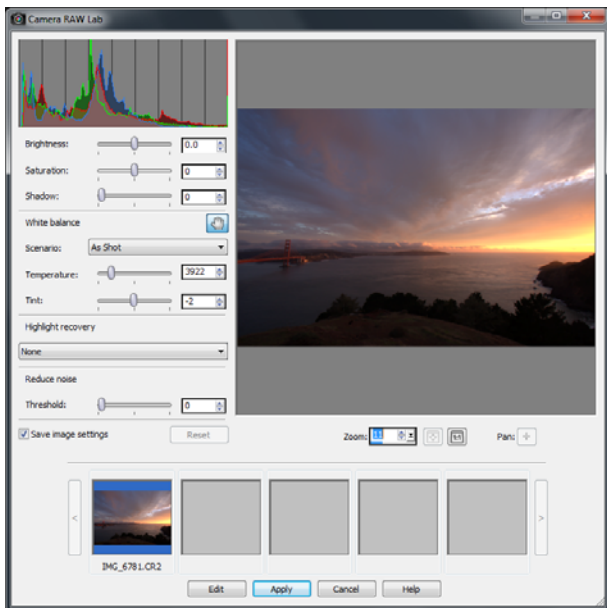

## To launch the Camera RAW Lab

- Do one of the following:
  - In the Manage workspace, select **File ▶ Open ▶ Filename**.
  - In the Edit workspace, drag a thumbnail from the Organizer palette to the image window, or double-click the thumbnail.

The Camera RAW Lab dialog box opens with the image.

## To adjust settings for a RAW photo

- 1 In the Camera RAW Lab dialog box, do any of the following:
  - Drag the **Brightness**, **Saturation**, or **Shadow** sliders for a quick overall image adjustment.
  - In the White balance area, adjust color by clicking a preset lighting option from the **Scenario** drop-list, or by clicking the preview area to set the white point with the Dropper tool. You can also adjust or fine-tune color with the **Temperature** and **Tint** sliders.
  - In the Highlight recovery area, click an option in the drop-list. Highlight recovery works particularly well on images that are overexposed — it can help restore detail in blown-out areas.
  - Drag the **Threshold** slider in the Reduce noise area to smooth digital noise.

You can preview the changes to the photo in the Preview area.

If you want to keep the settings for future use, check the **Save image settings** checkbox.

- 2 Click one of the following:
  - **Reset** — resets the settings to their original values

- **Edit** — applies the settings and opens the photo in the Edit workspace. When you edit a RAW photo, you must save it to a JPEG, TIFF, or another writable file format.
- **Apply** — applies the settings, and exits the Camera RAW Lab
- **Cancel** — exits the Camera RAW Lab without adjusting the photo's settings



Image settings for RAW images are saved to a database. Changes to the file name or file location can be tracked in the database only if you make the changes in Corel PaintShop Pro.

## Applying edits to multiple RAW photos

A photographer is often faced with organizing and processing large numbers of photos, especially if you use a DSLR camera. You may find that you're downloading a batch of photos taken under similar conditions, all with similar processing needs. With Corel PaintShop Pro, you can copy the edits you made to a photo in the Camera RAW Lab, and quickly apply the same edits to a batch of photos. For more information about applying edits to multiple photos, see "Capturing and applying edits to multiple photos" on page 129.

## Converting RAW photos to another file format

The RAW file format is read-only and the settings for a RAW file are stored as a separate header. It is these settings that you can adjust in the Camera RAW Lab. However, to use the editing features in the Adjust and Edit workspaces, you need save the RAW file to a different file format, such as JPEG, TIFF, or the native format, .pspimage. To quickly convert the file, you can use Convert RAW.

## To convert a RAW file to another file type

- 1
- 2 In the Organizer palette, select one or more RAW file thumbnails.
- 3 Right-click a selected thumbnail, and click **Convert RAW**.
- 4 In the Batch Process dialog box, choose a file format from the **Type** drop-list.  
If you want to change the default conversion settings, click **Options**, and adjust the settings.
- 5 Click **Browse** and choose a folder in which the converted file will be saved.
- 6 Click **Start**.



You can rename converted files by clicking **Modify**, choosing an option from the **Rename Options** list, and clicking **Add**.

## Working with XMP files

XMP files are metadata sidecar files that accompany RAW files. They are a standard way of saving edits without changing the original RAW file. If you plan to use another RAW image-editor with your files, XMP files will let you work between the applications more easily. You can read, save, copy, and paste XMP metadata for your RAW files.

### To read and import metadata in XMP files

- In the **Manage** workspace, right-click one or more RAW photo thumbnails, and choose **RAW Metadata > Read Metadata from File**.

### To save edits to XMP files

- In the **Manage** workspace, right-click one or more RAW photo thumbnails, and choose **RAW Metadata > Save Metadata To File**.

## To copy and paste metadata between XMP files

- 1 In the Manage workspace, right-click the thumbnail of the RAW image that has the metadata that you want to copy.
- 2 Choose **RAW Metadata > Copy**.
- 3 Select one or more RAW photo thumbnails to which you want to apply the metadata.
- 4 Right-click the selected thumbnails and choose **RAW Metadata > Paste**.





When you view your photos in Corel PaintShop Pro, you may notice problems that you want to correct. In some photos, the problems are obvious, such as when the subject is too dark. In other photos, you may sense the need for improvement but not know what to fix. With Corel PaintShop Pro, you can correct specific aspects of a photo or allow the program to make basic photo adjustments.

This section presents the following topics:

- Fixing common problems
- Rotating images
- Cropping images
- Straightening images
- Correcting photographic perspective
- Making basic photo corrections automatically
- Brightening images
- Darkening images
- Removing purple fringe
- Removing digital noise
- Removing chromatic aberrations
- Correcting lens distortions
- Adjusting white balance
- Adjusting brightness, contrast, and clarity

- Adjusting hue and saturation
- Adding or removing noise
- Controlling depth of field
- Blurring images
- Sharpening images
- Softening images
- Resizing images

## Fixing common problems

Corel PaintShop Pro provides many fast and powerful commands and tools to help you correct some common photographic problems. You can use the table below as a starting point for making your photos as good as they can be. Some correction commands open a dialog box in which you can choose options and modify the correction.

If you intend to crop or resize the photo, you should perform this action first and then apply a correction from the following table.

Problem	How to solve it
The overall photo should look better.	To apply a set of basic photo corrections automatically, choose <b>Adjust ▶ One Step Photo Fix</b> . To fine-tune and apply a set of basic photo corrections, choose <b>Adjust ▶ Smart Photo Fix</b> .

## Problem

## How to solve it

---

Part of the photo is too dark (underexposed).

To apply a quick adjustment to a photo's dark regions, choose **Adjust ▶ Fill Flash** or **Adjust ▶ Brightness and Contrast ▶ Fill Light/Clarity**. To apply a comprehensive set of adjustments, choose **Adjust ▶ Smart Photo Fix**. To access commands for correcting brightness and contrast, choose **Adjust ▶ Brightness and Contrast**. In particular, try the **Curves** and **Levels** commands.

---

Part of the photo is too light (overexposed).

To apply a quick adjustment to a photo's light regions, choose **Adjust ▶ Backlighting**. To apply a comprehensive set of adjustments, choose **Adjust ▶ Smart Photo Fix**. To access commands for correcting brightness and contrast, choose **Adjust ▶ Brightness and Contrast**. In particular, try the **Curves** and **Levels** commands.

---

A specific part of the photo is too dark or too light.

Carefully using a selection tool, select only the overexposed or underexposed part of the photo. Then, apply one of the adjustments previously described in this table. **Note:** The **One Step Photo Fix** and **Smart Photo Fix** commands work on the entire image, even if you've made a selection. For more information, see "Working with selections" on page 291.

---

## Problem

## How to solve it

---

The photo's contrast is too low or too high.

To adjust the contrast and optionally adjust other settings, choose **Adjust ▶ Smart Photo Fix**. Or, choose **Adjust ▶ Brightness and Contrast ▶ Brightness/Contrast**.

---

You have a set of bracketed digital photos, but need a way to merge them into one.

Choose **File ▶ HDR ▶ Exposure Merge**, and use this command to combine the best details from two to nine bracketed photos into one photo.

---

The photo has a color cast or other unnatural colors resulting from its being taken indoors without a flash.

To remove a color cast, choose **Adjust ▶ Brightness and Contrast ▶ Curves**. To apply a comprehensive set of adjustments, choose **Adjust ▶ Smart Photo Fix**. To access commands for making various brightness and contrast corrections, choose **Adjust ▶ Brightness and Contrast**.



---

Someone in the photo has unnatural-looking skin tones.

To adjust the photo's tonal balance, choose **Adjust ▶ White Balance**.

---

A scanned photo has scratches or tears.

On the Tools toolbar, choose the **Scratch Remover** tool , the **Object Remover** tool , or the **Clone Brush** tool . For more information, see "Retouching and restoring images" on page 229.

---

## Problem

## How to solve it

---

Tiny specks (noise) of unnatural color can be seen, especially on a magnified view.

To apply noise correction automatically, choose **Adjust ▶ One Step Noise Removal**. To use advanced options for noise correction, choose **Adjust ▶ Digital Noise Removal**. To remove other types of image noise, choose **Adjust ▶ Add/Remove Noise**, and then choose an appropriate command.

---

Purplish fringe and other color aberrations can be seen on edges in the photo.

To remove purple fringe automatically, choose **Adjust ▶ One Step Purple Fringe Fix**. To use advanced options for correcting chromatic aberrations, choose **Adjust ▶ Chromatic Aberration Removal**.





---

Someone in the photo has red-eye.

To remove red-eye quickly, choose the **Red Eye** tool . To use advanced options for red-eye removal, choose **Adjust ▶ Red Eye Removal**.

---

Someone in the photo has skin blemishes, unpolished teeth, or exceptionally pale skin.



On the Tools toolbar, choose the **Makeover** tool . On the Tool Options palette, set the mode to **Blemish Fixer** , **Toothbrush** , or **Suntan** .

---

The photo appears foggy or hazy.

To improve a poorly exposed image, choose **Adjust ▶ Brightness and Contrast ▶ Levels**. To improve overall clarity, choose **Adjust ▶ Brightness and Contrast ▶ Local Tone Mapping**.

---

Problem	How to solve it
The photo doesn't appear sharp.	To apply high-frequency sharpening, choose <b>Adjust ▶ Sharpness ▶ High Pass Sharpen</b> . To apply other forms of sharpening, choose <b>Adjust ▶ Sharpness</b> and choose a command.
The photo needs to be straightened.	On the Tools toolbar, choose the <b>Straighten</b> tool  . For more information, see "Retouching and restoring images" on page 229.
The perspective of objects in the photo appears incorrect.	On the Tools toolbar, choose the <b>Perspective Correction</b> tool  . For more information, see "Retouching and restoring images" on page 229.
The photo quality is affected by a lens distortion.	Choose <b>Adjust ▶ Barrel Distortion Correction</b> , <b>Adjust ▶ Fisheye Distortion Correction</b> , or <b>Adjust ▶ Pincushion Distortion Correction</b> . For more information about lens distortions, see "Correcting lens distortions" on page 180.
An unwanted pattern appears on a scanned image.	Choose <b>Adjust ▶ Add/Remove Noise ▶ Moire Pattern Removal</b> .
A scanned photo appears old and faded.	Choose <b>Adjust ▶ Color ▶ Fade Correction</b> .

## Rotating images

You can rotate an image by 90 degrees to change its orientation to landscape (horizontal) or portrait (vertical). If your camera contains sensors that tag photos taken in portrait orientation, your photos are automatically rotated to the correct orientation.



*You can rotate an image in Corel PaintShop Pro.*

You can also rotate an image to any angle by specifying a degree of rotation or by rotating it interactively on the canvas. For information about rotating an image to straighten it according to reference points within the image, such as the horizon, see “Straightening images” on page 162.

You can also use the Manage workspace to apply lossless rotation to JPEG images while retaining all of the original image data.

## To rotate an image

Edit workspace



- Select an image, and perform a task from the following table.

To	Do the following
Rotate an image 90 degrees clockwise or counterclockwise	Choose <b>Image ▶ Rotate Right</b> , or choose <b>Image ▶ Rotate Left</b> .
Rotate an image to a specific angle	Choose <b>Image ▶ Free Rotate</b> . In the Free Rotate dialog box, choose either the <b>Right</b> option or the <b>Left</b> option to set the direction of rotation. In the <b>Degrees</b> group box, choose the <b>Free</b> option, and type or set a value in the control.

Rotate an image interactively

On the Tools toolbar, choose the **Pick** tool . Rotate the image by dragging the rotation handle (the square connected by a line to the rotation pivot point). The cursor changes to two curved arrows when it is positioned over the rotation handle.



You can also rotate an image by clicking the **Rotate Right**  or **Rotate Left**  button on the Standard toolbar.

If you want to change the center of rotation before you interactively rotate the image, hold down **Ctrl**, and drag the rotation pivot point (the circle at the center of the image) to a new position.

## Cropping images

You can remove unwanted portions of an image to create stronger compositions or to draw attention to another area of the image. Corel PaintShop Pro helps you crop by providing presets to common image sizes, such as 4 × 6 inches or 10 × 15 centimeters.

Cropping reduces the amount of hard drive memory required for storing the image. In addition, cropping can improve color corrections by eliminating extraneous areas of color. If a photograph requires both cropping and color correction, you should crop the image first and then apply the color correction.





Floating toolbar for the Crop tool

Before printing an image, you can crop it to a specific print size. In addition, you can select an area within the image and then crop the image to the selection borders. You can also create a new image from the cropped area.

You can also rotate the crop rectangle and stretch it outside the bounds of the image. In this case, the crop command resizes the image so that the whole new image fits into the new shape.

You can crop an image based on its opaque (nontransparent) areas. Cropping in this way is useful when you want to eliminate transparent areas at the edges of the image. You can also set the crop area to cover the opaque area of a single layer or of an entire image.

***Important!** Cropping permanently removes the image area outside the crop rectangle. To preserve the original photo, use the Save As command, and save the cropped version of your image to a new filename.*

## To crop an image

Edit workspace

- 1 On the Tools toolbar, choose the **Crop** tool .

By default, the crop rectangle appears on the image, and the area outside the crop rectangle is shaded.

- 2 Adjust the crop area size by dragging any of the handles or edges. To reposition the crop rectangle, place the cursor inside and drag. You can use a preset crop size by choosing an option from the **Presets** drop-list on the floating toolbar for the Crop tool, or from the drop-list on the Tool Options palette.
- 3 When you're ready to crop the image, click the **Apply** button  on the Tool Options palette or on the floating toolbar for the Crop tool.

## You can also

Apply the crop by using your mouse or keyboard	Double-click inside the crop rectangle, or press <b>Enter</b> .
Set the size of the crop rectangle on the Tool Options palette	Specify the <b>Pixel Dimensions</b> values in the <b>Width</b> and <b>Height</b> controls or the <b>Document size</b> values in the <b>Width</b> , <b>Height</b> and <b>Units</b> controls.
Constrain the crop area to its current proportions	Mark the <b>Maintain aspect ratio</b> check box on the Tool Options palette. This option is available only for custom-defined crop rectangles.
Rotate the crop rectangle by 90 degrees	Click the <b>Rotate Crop Rectangle</b> button  on the floating toolbar.
Rotate the crop rectangle by a specific angle	Specify the degree of rotation in the <b>Angle</b> controls on the Tool Options palette.

## You can also

---

Freely rotate the crop rectangle	Drag the square end of the rotation handle or a corner point. This feature can be helpful when, for example, you want to straighten and then crop a crookedly scanned photo.
Move the rotation axis point of the crop rectangle	Specify the <b>X</b> and <b>Y</b> coordinates under <b>Pivot</b> on the Tool Options palette or hold down <b>Ctrl</b> , and then drag the axis point of the rotation handle (the circular end of the handle) to a new position.
Move the rotation axis point to the center of the crop rectangle	Click the <b>Center Pivot</b> button  on the Tool Options palette.
Modify the crop shading area	Choose <b>File</b> ▶ <b>Preferences</b> ▶ <b>General Program Preferences</b> , choose <b>Transparency and Shading</b> from the list, and specify the settings for <b>Color</b> and <b>Opacity</b> in the <b>Shading</b> group box.
Turn off the shading option	Choose <b>File</b> ▶ <b>Preferences</b> ▶ <b>General Program Preferences</b> , choose <b>Transparency and Shading</b> from the list, and unmark the <b>Enable crop shade area</b> check box in the <b>Shading</b> group box.
Turn off the floating toolbar for the Crop tool	Choose <b>File</b> ▶ <b>Preferences</b> ▶ <b>General Program Preferences</b> , choose <b>Transparency and Shading</b> from the list, and unmark the <b>Enable floating crop toolbar</b> check box in the <b>Shading</b> group box.

---

## You can also

---

Choose not to display the crop rectangle when the tool is selected

Choose **File** ▶ **Preferences** ▶ **General Program Preferences**, choose **Transparency and Shading** from the list, and unmark the **Automatically display crop rectangle** check box in the **Shading** group box.

---

Clear the crop area

Click the **Clear** button  on the floating toolbar for the Crop tool.



After cropping an image, you may notice that the Width and Height values on the Tool Options palette are each set at 0.100. These settings do not reflect the cropped image size. To see the image size dimensions after cropping, choose **Image** ▶ **Image Information**.

If you need to, you can stretch the rotated crop rectangle outside the bounds of the image. The area outside the original image will be transparent or filled with the background, depending on which layer you are working on.

## To crop an image for printing

Edit workspace

- 1 On the Tools toolbar, choose the **Crop** tool .
- 2 Define the crop area by dragging within the image.
- 3 On the Tool Options palette, mark the **Specify Print Size** check box.

**Note:** If the **Specify Print Size** check box is marked, the image resolution changes when you change the values in the **Height** and **Width** controls of either the **Pixel Dimensions** or the **Document size**. The current resolution appears to the right of the **Units** drop-list.

- 4 In the **Units** drop-list, select **Inches** or **Centimeters**.

**Note:** The **Pixels** option is unavailable for this method of cropping.

- 5 Type or set the dimension values in the **Height** and **Width** controls. The final crop area is sized as specified, and the image resolution is reduced or increased as needed.
- 6 Click the **Apply** button  on the Tool Options palette, or on the floating toolbar for the **Crop** tool.

## To crop to a selection in an image

Edit workspace



- 1 Make a selection in the image.
- 2 Choose **Image** ▶ **Crop to Selection**.



The selection can be any shape. Corel PaintShop Pro positions a crop area rectangle around irregularly shaped selections.



If you crop to a selection that is feathered, the current background color fills in the feathered region of the selection.



You can also crop to the selection by choosing the **Crop** tool  and clicking **Current Selection**  in the **Snap crop rectangle to** group box on the Tool Options palette. Adjust the crop area, and click **Apply** .

## To crop to an opaque area in a layer or an image

Edit workspace

- 1 Click the **Crop** tool .
- 2 On the Tool Options palette, select one of these options from the **Snap Crop Rectangle To** group box:
  - **Layer Opaque**  — selects opaque areas in the current layer
  - **Merged Opaque**  — selects opaque areas in all layers

- 3 Adjust the crop area.
- 4 Click the **Apply** button  on the Tool Options palette, or on the floating toolbar for the **Crop** tool.





If any layer has a solid-color (nontransparent) background, the entire layer or image is selected as the crop area.

Opaque areas that are not rectangular may have transparent areas remaining after cropping.

## To create a new image by cropping

Edit workspace

- 1 On the Tools toolbar, choose the **Crop** tool .
- 2 Define the crop area by dragging within the image.
- 3 Click the **Crop as new image** button  on the Tool Options palette, or on the floating toolbar for the **Crop** tool.

A new image is created, but the cropped image remains unchanged, and remains the active image.



This feature offers a useful method of creating individual images from a scan of multiple images. For example, if you scan four photos in one scanning session, you can use this feature to quickly separate each photo into an individual image file.

## Straightening images



You can easily straighten crooked images by aligning a straightening bar with an image feature. Corel PaintShop Pro rotates the image so that this straightening bar is perfectly horizontal and vertical. This feature is especially useful when an image has a strong vertical or horizontal feature, such as a building or horizon.



*The Straighten tool lets you position a straightening bar within an image.*

## To straighten an image

Edit workspace

- 1 On the Tools toolbar, choose the **Straighten** tool .
- 2 A straightening bar with end handles appears on the image.  
Drag each handle of the straightening bar to align it with the part of the image that you want to straighten.
- 3 On the Tool Options palette, choose one of the following options from the **Mode** drop-list:
  - **Auto** — automatically straightens the image based on the position of the straightening bar
  - **Make vertical** — rotates the image to make the straightening bar vertical
  - **Make horizontal** — rotates the image to make the straightening bar horizontal
- 4 Click the **Apply** button .

## You can also

Straighten a single layer	Before clicking the <b>Straighten</b> tool, click the layer name on the Layers palette.
Straighten all layers in the image	Mark the <b>Rotate all layers</b> check box on the Tools Options palette.
Choose a specific angle for the straightening bar	Type or set a value in the <b>Angle</b> control on the Tools Options palette.
Crop the edges of the image to make it rectangular after straightening	Mark the <b>Crop image</b> check box on the Tools Options palette.
Fill the edge areas of your image with the background color	Unmark the <b>Crop image</b> check box on the Tools Options palette.



You can also double-click the image to apply the command.

## Correcting photographic perspective

When you take pictures of tall or wide objects, the resulting photographs may have perspective distortion — that is, the objects may seem to be leaning or angled. This distortion occurs when the camera is at an angle to the subject.

By using the Perspective Correction tool, you can fix perspective distortion, such as the angled sides of a building. You can also fix photographic perspective in an entire layer by using the Pick tool.







*Using the Perspective Correction tool changes the angle of the building.*

## To correct perspective in a photo

Edit workspace

- 1 On the Tools toolbar, choose the **Perspective Correction** tool .  
A bounding box with corner handles appears on the image.
- 2 On the Tool Options palette, choose settings for the following controls:
  - **Grid lines** — lets you type or set the number of gridlines to display
  - **Crop image** — recrops the image to a rectangular shape after the perspective is applied**Note:** Marking the **Crop image** check box deletes the areas of the image that fall outside the rectangle.
- 3 Drag each handle to the corner of the object that should be rectangular.
- 4 Click the **Apply** button .



You can also apply the command by double-clicking the image. To reset the perspective correction box to the original rectangle, click **Cancel**  on the Tool Options palette.

## To correct perspective in an image layer

Edit workspace

- 1 On the Layers palette, select the layer to correct.
- 2 Choose **View ▶ Grid** to display the gridlines.

The gridlines help you correct lines in your photograph that should be vertical or horizontal.

**Note:** To adjust the grid settings, choose **View ▶ Change Grid, Guide & Snap Properties**, and then use the controls on the **Grid** page of the dialog box.

- 3 On the Tools toolbar, choose the **Pick** tool .

A bounding box appears around the entire layer.

**Note:** It may be helpful to expand the image window so that you can see all of the corner handles of the current layer. To expand the image window, drag from a corner or side.

- 4 Hold down **Ctrl**, and drag a corner handle on the selected layer.

The image is updated when you finish dragging. Continue adjusting the perspective until the image looks correct.



If the correction causes some image data to fall outside the image canvas, you can restore that data by increasing the size of the canvas. For more information about changing the canvas size, see “Resizing the canvas” on page 271.

## Making basic photo corrections automatically

If you are not sure what adjustments to make to a photo, you can apply either the One Step Photo Fix command or the Smart Photo Fix command and see if you like the results. The One Step Photo Fix command automatically applies a predetermined set of color balancing and sharpening corrections to your photo — all you need to do is select the command. If you want the option of fine-tuning the

same corrections before applying them, you can use the Smart Photo Fix command.



*You can use the One Step Photo Fix command to improve the exposure and white balance of images quickly and easily.*

The advanced options of the Smart Photo Fix feature let you adjust white balance by identifying the neutral areas in the photo (black, gray, and white), which are used as sampling points. The advanced options also let you modify the darkest and lightest pixels of the photo without affecting the photo's white balance.



*Neutral sampling points identified by using the advanced options of the Smart Photo Fix command*

## To apply basic corrections with One Step Photo Fix

Edit workspace

- Choose **Adjust ▶ One Step Photo Fix**.

After a brief pause, several basic corrections are applied to your photo.



The corrections applied are identical to what would be applied by accepting the suggested settings of the Smart Photo Fix feature.



If you are not satisfied with the changes made to your photo, choose **Edit ▶ Undo**. Then, choose **Adjust ▶ Smart Photo Fix**, and adjust the available settings. You can also try using other Adjust menu commands, such as **Brightness and Contrast ▶ Curves** or **Brightness and Contrast ▶ Levels**.

## To fine-tune basic corrections with Smart Photo Fix

Edit workspace

- 1 Choose **Adjust ▶ Smart Photo Fix**.

The Smart Photo Fix dialog box appears. In the upper portion of the dialog box, the Before pane shows the original photo. The After pane shows how the photo would appear after applying the suggested set of basic adjustments.

- 2 Perform one or more tasks from the following table, and click **OK**.

To	Do the following
Brighten or darken the photo	In the <b>Brightness</b> group box, type or set a value in the <b>Overall</b> , <b>Shadows</b> , and <b>Highlights</b> controls, or adjust their corresponding sliders. <b>Note:</b> Positive settings brighten the photo, and negative settings darken the photo.
Increase or decrease saturation	Type or set a value in the <b>Saturation</b> control, or adjust the slider. <b>Note:</b> Positive settings make colors more vibrant; negative settings make colors less vibrant.
Sharpen the edges of the photo	Type or set a value in the <b>Focus</b> control, or adjust the slider.



You can reset all settings to their initial values by clicking **Suggest Settings**, or to null settings by clicking the **Reset to Default** button .

To use advanced settings of the Smart Photo Fix feature, mark the **Advanced Options** check box.

## To use the advanced options of Smart Photo Fix

Edit workspace

- 1 In the Smart Photo Fix feature dialog box, mark the **Advanced Options** check box.  
Additional controls appear in the dialog box.
- 2 Perform one or more tasks from the following table, and click **OK**.

To	Do the following
Use sampling points for color balancing	Mark the <b>White Balance</b> check box. The photo's neutral areas (black, gray, and white) are identified in the Before pane.  Note: Some photos have no black, gray, or white areas, so no sampling points are identified.
Ignore the photo's sampling points	Unmark the <b>White Balance</b> check box. Re-marking the check box restores the sampling points.
Add sampling points	Click areas in the Before pane that should be black, gray, or white. The After pane is updated.
Delete a sampling point	Click the sampling point in the Before pane. Both the Before and After panes are updated.
Darken the darkest pixels in the photo	Drag the <b>Black</b> slider to the right, or specify a value in the control beside the slider.
Lighten the lightest pixels in the photo	Drag the <b>White</b> slider to the right, or specify a value in the control beside the slider.



To avoid introducing errors in white balance when you add sampling points, do not click any color other than black, white, or gray (for example, do not click a region that you know is blue). Click only the points that you know should be black, white, or gray.

Sampling points cannot be dragged or moved.

The histogram is for display only — you cannot drag or adjust any part of it. The gray portion represents the original (Before) photo, and the red overlay portion reflects the adjustments. The black triangle moves in tandem with the Black slider, and the white triangle moves in tandem with the White slider. For more information about the Histogram, see “Adjusting brightness, contrast, and clarity” on page 186.

## Brightening images

Lighting problems are common in photography. Photos taken in bright light often lack detail in the shadow areas. If your photo’s background is too dark, or if the difference between the photo’s light and dark areas is too great, you can lighten the darker, underexposed areas. You can adjust saturation, which is the purity or vividness of a color.

For more information about other brightening features, including Fill Light/Clarity, see “Adjusting brightness, contrast, and clarity” on page 186.

### To brighten a photo

Edit workspace

- 1 Choose **Adjust ▶ Fill Flash**.
- 2 Type or set a value from 0 to 100 in the **Strength** control to determine how much to lighten the darker areas.
- 3 Type or set a value in the **Saturation** control to determine the overall saturation of the photo’s colors.  
Values less than 0 reduce saturation; values greater than 0 increase saturation.
- 4 Click **OK**.



If a photo has areas that are too light as well as areas that are too dark, choose **Adjust ▶ Fill Flash**, and then choose **Adjust ▶ Backlighting**.

## Darkening images

Sometimes photos have too much lighting from the background, which essentially washes out the entire image. A similar problem involves photos with too much flash on the subject. You can darken the bright, overexposed areas of a photo.

### To darken a photo

Edit workspace

- 1 Choose **Adjust ▶ Backlighting**.
- 2 Type or set a value from 0 to 100 in the **Strength** control to determine how much to darken the lighter areas.
- 3 Type or set a value in the **Saturation** control to determine the overall saturation of the photo's colors.

Values less than 0 reduce saturation; values greater than 0 increase saturation.

- 4 Click **OK**.



If a photo has areas that are too light as well as areas that are too dark, choose **Adjust ▶ Fill Flash**, and then choose **Adjust ▶ Backlighting**.

## Removing purple fringe

A common problem of digital photos is the presence of purple halos surrounding overexposed areas of a color photo. This problem, which is called fringing, is often quite evident when a bright sky appears in



the background of a photo and faint purple halos appear on the edges of the photo subject. With Corel PaintShop Pro, you can quickly identify this problem and remove it from your photo.

## To remove purple fringe from a photo

Edit workspace

- Choose **Adjust ▶ One Step Purple Fringe Fix**.

After a brief pause, your photo is automatically adjusted.

## Removing digital noise

The term “noise” as it relates to photos refers to small specks of color that interfere with image clarity. These specks are usually caused by poor lighting conditions or the limitations of the sensor in your digital camera. For example, when you zoom in on a photo of a clear blue sky, you may see tiny specks of orange, red, purple, green, or other colors.

Corel PaintShop Pro gives you two fast, powerful commands for removing noise from your photos: One Step Noise Removal and Digital Noise Removal. When you use a noise removal command, the program analyzes your photo, identifies the noise artifacts, and applies corrections based on these identified areas, while preserving the important edge details of your photo.



*The image on the left looks grainy because of digital camera noise. The image on the right appears smoother and less grainy after the noise has been removed.*

You can automatically apply noise correction to your photo with the One Step Noise Removal command. You can also control more precisely how the same corrections are applied by using the more comprehensive Digital Noise Removal command.

## Digital Noise Removal command

The Digital Noise Removal command gives you more control over the removal of digital camera noise in your photos.

Photos taken with the same camera tend to have noise in the same areas. You can create a preset to apply the same corrections to all of these photos.

This command could be an ideal solution in the following scenarios:

- For photos that most likely contain excessive noise (such as a video whiteboard capture), using the command with low settings can help make the overall image clearer without excessive blurring.
- For photos taken with normal settings, this command is best used only on key areas needing correction, such as image artifacts surrounding the subject area.
- For photos containing areas that you want to exclude from the noise correction, you can specify the color ranges to preserve or discard. For example, you may want to protect skin tones in a photo from having any correction applied to them. You can define as many of these protected regions as you like.

## To remove digital noise quickly

Edit workspace

- Choose **Adjust ▸ One Step Noise Removal**.

After a brief pause, the noise is automatically removed.

## To use advanced options for removing digital noise

Edit workspace

- 1 Choose **Adjust ▶ Digital Noise Removal**.

The Digital Noise Removal dialog box appears.

**Note:** The three crosshairs appear on the image preview in the Remove Noise tabbed area. The crosshairs represent noise samples located in the image's light, midtone, and dark areas. You can move a crosshair by dragging the bounding box in the before pane, which moves the sampling region accordingly.

- 2 In the Remove Noise tabbed area, mark the **Link detail sizes** check box to adjust the **Small**, **Medium**, and **Large** settings in proportion to each other.

- 3 Type or set values in the **Small**, **Medium**, and **Large** controls.

These controls define the amount of correction to apply to small, medium, and large noise patterns.

- 4 Type or set a value in the **Correction blend** control to determine to what degree the corrected image will be blended in with the original.

The blending values range from 0.0 (no noise reduction) to 100.0 (full processing of the entire image). The default value is 70.

- 5 Type or set a value in the **Sharpening** control to determine the degree of sharpening, if any, to apply to the image after the noise reduction is applied.

The default value is 0.

- 6 Click **OK**.

### You can also

---

Set corrections for light, midtone, and dark areas independently

Unmark the **Link detail sizes** check box, and type or set values in the **Small**, **Medium**, and **Large** controls.

---

## You can also

---

View close-ups of sampling regions	Click a crosshair to see the area close up in the Before and After panes.
Add a sampling region crosshair	Drag in the Before pane.
Delete a sampling region crosshair	In the Before pane, drag a corner of the correction box to its diagonally opposite corner.

---



You can have a maximum of 10 sampling regions.

You should avoid sampling an image edge, or pure black or pure white regions of the image, which can result in excessive smoothing.

The Digital Noise Removal command is not designed to remove moire patterns. For information about removing moire patterns, see “To remove moire patterns” on page 208.



To save settings as a preset specific to an image and camera, mark the **Camera preset** check box and click the **Save Preset** button . When the **Camera preset** check box is marked, the **Load Preset** drop-list displays only previously saved camera presets, not the standard presets. To save settings as a standard preset, unmark the **Camera preset** check box, and click the **Save Preset** button.

For best results when working with JPEG images, choose **Adjust ▶ Add/Remove Noise ▶ JPEG Artifact Removal** before using the **Adjust ▶ Digital Noise Removal** command.

## To protect image areas from noise corrections

Edit workspace

- 1 Choose **Adjust ▶ Digital Noise Removal**.

The Digital Noise Removal dialog box appears.

- 2 Click the **Protect Image** tab.
- 3 In the Before pane, pan and zoom as necessary so that you can view the region you want to protect.
- 4 Hold down **Ctrl**, and drag over the region you want to protect.  
**Note:** Holding down **Ctrl** does not create a corresponding crosshair in the image window of the Remove Noise tabbed area.
- 5 In the **Selected hue range** group box, type or set values in the **Hue** and **Range** controls.  
**Note:** The existing settings reflect the area sampled. You can manually adjust the hue knob by dragging it inside the ring.
- 6 In the **Protect selected hue range** group box, drag any of the seven graph handles downward to apply less correction and smoothing to the corresponding segment of the hue range.  
For example, dragging just the middle graph handle to the bottom of the graph completely suppresses the midtone of that hue range.  
**Note:** The graph handles cannot be dragged laterally.
- 7 Click **OK**.



You can remove color adjustments for a selected color range by clicking **Reset Current**. To remove all color adjustments, click **Reset All**.

## Removing chromatic aberrations

Chromatic aberration occurs when the camera records incorrect colors within the image. In conventional film cameras, chromatic aberration is usually caused by a lens defect. In digital cameras, several factors can contribute to chromatic aberration, including the following:

- The inherent lens aberration in the camera may cause fuzziness at image edges. Photos taken with telephoto and zoom lenses are

more prone to contain chromatic aberrations because of the way in which digital cameras capture light rays far from the optical axis.

- The auto-exposure feature of the camera, which estimates the correct exposure setting, may cause sensor blooming.
- Different colors may be caught by different camera sensor elements, and they may combine to make one pixel. This process is called demosaicing.
- Activities such as artifact removal, noise removal, and sharpening may occur inside the camera after processing.

In your own digital photos, you may notice chromatic aberrations in photos with the following content:

- the sky seen through tree branches or leaves
- the edges of interior doors or windows through which bright light enters
- fireworks or city lights
- fluorescent light fixtures or bare lightbulbs
- sun or light reflections on water
- reflections on chrome
- the edges of backlit objects
- sunlit white shirts against a dark background

After identifying these types of color defects, you can reduce or eliminate them.

## To remove chromatic aberrations from a photo

Edit workspace

- 1 Choose **Adjust ▶ Chromatic Aberration Removal**.

The Chromatic Aberration Correction dialog box appears.

- 2 Ensure that the Before and After panes are visible at the top of the dialog box.
- 3 Set the zoom control in the dialog box to at least 200%.

The zoom control is located below the Before and After panes. Zooming to 200% helps target the problem areas in the photo.

- 4 Click the **Pan** button , and pan the image to set a viewable image area in the Before pane.
- 5 In the Before pane, drag to define the area needing correction.

**Note:** The area needing correction is called the sample box. You can create up to 10 sample boxes. Each sample box is represented as “Sample *n*” (where *n* is a number from 1 to 10) in the **List of Samples** area in the center of the dialog box. Each sample listing has a color swatch to the left, indicating a color average for the sampled area.

- 6 Choose a sample entry from the **List of Samples** area.
- 7 Type or set a value in the **Range** control to determine the color range of the active sample, which affects the pixel range to be corrected.

The range you specify is represented in the color box directly above the **Range** control.

- 8 Type or set a value in the **Radius** control to determine the size of the sample’s aberration.

**Note:** The default value is 10. Values from 4 to 20 usually produce the most acceptable results. Values greater than 10 are useful on sampling areas that enclose sensor blooming aberrations. Values less than 10 are useful when you are removing 1- or 2-pixel aberrations caused by demosaicing, as well as when you are working on images of less than one megapixel. Set the **Radius** control to the smallest setting that effectively removes the aberration.

- 9 Click **OK**.

## You can also

Resize a sample box	Drag a sample box handle.
Delete a sample box button in the dialog box	Click a sample box, and click <b>Remove</b> .
Delete a sample box	Drag a corner onto its diagonally opposite corner, and stop dragging when the corners meet.
Display the affected image areas	Mark the <b>Show Differences</b> check box. The affected areas appear in the After pane as white areas on black. Brighter areas represent greater degrees of correction.
Preview the results on the image	Mark the <b>Show Differences</b> check box, and make sure the <b>Preview on Image</b> check box is marked.



To create more than 10 sample boxes, you can apply the corrections and then restart the effect.



You can automatically create a new layer on which the corrected image resides by marking the **Result on New Layer** check box. This option protects your original image on its own layer. If you do not mark this check box, the corrections are applied on the same layer as the original image.

You can limit the number of “false corrections” by making a selection and then marking the **Result on New Layer** check box. You can also use this command on separate layers of an image.

## Correcting lens distortions

Camera lenses can create distortions in photos. These distortions appear most often in wide-angle photos, in close-up photos taken



with cameras with fixed focal ranges, and in photos taken with cameras that have low-quality lenses (such as disposable cameras).

***Important!** It is strongly recommended that you correct the lens distortion in a photo before cropping it.*

## Types of lens distortion

Corel PaintShop Pro can correct three common types of lens distortion, all of which make straight lines appear curved:

- **Barrel distortion** — Photo looks pushed out at the centre. For distortion corrections to work properly, the axis of the camera lens must coincide with the centre of the image.
- **Fisheye distortion** — Photo looks as though it has been pasted onto a sphere or blown up like a balloon. The edges of the photo look compressed.
- **Pincushion distortion** — Photo looks pushed in at the center

## To correct barrel distortion

Edit workspace

- 1 Choose **Adjust ▶ Barrel Distortion Correction**.

The Barrel Distortion Correction dialog box appears.

- 2 Look for curved lines in the image, and straighten them by typing or setting an appropriate value in the **Strength** control.
- 3 Click **OK**.



By marking the **Preserve central scale** check box, you can add or remove pixels from the image, which changes the scale at the center of the picture. Changes to the width and height of the original image are displayed in the **Result Size** group box.

## To correct fisheye distortion

Edit workspace

- 1 Choose **Adjust ▶ Fisheye Distortion Correction**.

The Fisheye Distortion Correction dialog box appears.

- 2 Remove the distortion by typing or setting an appropriate value in the **Field of View** control.
- 3 Click **OK**.



By marking the **Preserve central scale** check box, you can add or remove pixels from the image, which changes the scale at the center of the picture. Changes to the width and height of the original image are displayed in the **Result Size** group box.

## To correct pincushion distortion

Edit workspace

- 1 Choose **Adjust ▶ Pincushion Distortion Correction**.

The Pincushion Distortion Correction dialog box appears.

- 2 Look for lines in the image that are curved, and type or set a value in the **Strength** control until they become straight.
- 3 Click **OK**.



By marking the **Preserve central scale** check box, you can add or remove pixels from the image, which changes the scale at the center of the picture. Changes to the width and height of the original image are displayed in the **Result Size** group box.

## Adjusting white balance

You can often improve a photo dramatically by adjusting the colors. Different types of lighting, cameras, and the processing that occurs

inside the camera can cause incorrect coloring in photos. Scanned images may have unnatural color casts.

To create natural-looking colors and remove any color cast in your image, you can use the various color-balancing commands in Corel PaintShop Pro. By applying the commands to a selection or an entire image, you can do the following:

- tonally balance a photo's colors without affecting the luminance of the photo
- increase or decrease the red, blue, or green color channel by a percentage of the given channel
- restore color and contrast to faded photos
- create a photographic negative by replacing each pixel color with its opposite (for example, replace blue with yellow, black with white, yellow with blue, white with black, and so on)
- adjust the amount of red, green, and blue in your image as a way to make color corrections by changing the overall color cast

## To adjust white balance

Edit workspace

- 1 Choose **Adjust ▶ White Balance**.

The White Balance dialog box appears.

- 2 Mark the **Smart White Balance** check box.

This allows Corel PaintShop Pro to evaluate and make minor corrections to the image automatically.

- 3 Drag the temperature slider to the left for cooler colors (more blue), or to the right for warmer colors (more orange).
- 4 Click **OK**.



If you know what color temperature the photo should be, you can set precise tonal balance values by marking the **Advanced Options** check box and typing or setting the temperature values in the **Temperature** and **Tint** controls in the **White Balance** group box. You can tweak the colors by adjusting values in the **Temperature** and **Tint** controls in the **Enhance White Balance** group box.

## To mix color channels

Edit workspace

- 1 Choose **Adjust ▶ Color ▶ Channel Mixer**.

The Channel Mixer dialog box appears.

- 2 Do one of the following:

- To maintain a color image, select a color channel to edit from the **Output channel** drop-list.
- To change the image to monochrome (which looks like grayscale but has a color depth of 16 million colors), mark the **Monochrome** check box. **Grey** appears in the **Output channel** drop-list.

- 3 In the **Source Channels** group box, type or set values in the **Red**, **Green**, and **Blue** controls, or adjust the corresponding sliders, to change the percentage of that color in the channel.

For example, if you are editing the Red channel and set the **Red** control to 50%, the amount of red in the image is reduced to 50% of its original amount.

- 4 Adjust the **Constant** slider.

The slider is originally set at zero. If you want to darken the color channel, drag the slider to the left. If you want to brighten the color channel, drag the slider to the right.

- 5 Click **OK**.

## To correct faded colors

Edit workspace

- 1 Choose **Adjust ▶ Color ▶ Fade Correction**.

Drag in the Before pane to center an important part of the image (such as a face).

- 2 Adjust the value in the **Amount of correction** control until the image looks the most natural.

The default value is 45.

**Note:** Use the minimum value that produces a good correction. If you apply too much correction, highlight and shadow areas may lose detail, and objects may blend together.

- 3 Click **OK**.

## To create a photographic negative

Edit workspace

- Choose **Image ▶ Negative Image**.

## To change color cast

Edit workspace

- 1 Choose **Adjust ▶ Color ▶ Red/Green/Blue**.

The Red/Green/Blue dialog box appears.

- 2 In the **Red**, **Green**, and **Blue** controls, type or set a value to change the percentage for each color.

A value of 0% preserves the original value. To add more of a color, use a positive number. To remove some of a color, use a negative number.

**Note:** Reducing the amount of blue adds a yellow cast to the image, reducing the amount of green adds a magenta cast to the image, and reducing the amount of red adds a cyan cast to the image.

- 3 Click **OK**.

## Adjusting brightness, contrast, and clarity

Corel PaintShop Pro lets you adjust the brightness, contrast, and clarity in your photos. Contrast is the difference between the photo's lightest and darkest pixels. Clarity lets you adjust the level of detail in the image by analyzing contrast within localized areas.

By applying the commands to a selection or an entire image, you can do the following:

- manually adjust the brightness and contrast
- give your photo a crisp, focused look to make the subject more prominent
- adjust the individual brightness values in your image
- adjust the highlights, midtones, and shadows to provide smooth tonal transitions
- correct the exposure
- distribute the lightness values of pixels more evenly across the lightness spectrum from black to white
- increase the overall contrast when the histogram does not cover the entire lightness spectrum
- make adjustments to the brightness, contrast, and gamma in the image
- create a purely black-and-white image

### Histograms

A histogram lets you display the tonal range of an image and redistribute the balance of highlights, midtones, and shadows. In other words, the histogram can reveal whether your photo is underexposed, overexposed, or exposed properly.

Many digital cameras offer a histogram display on the camera's LCD, and some cameras even let you adjust the scene's histogram before you take the photo.

Corel PaintShop Pro has various commands that display the histogram in the dialog box. These commands include Curves, Levels, the advanced mode of Smart Photo Fix, and Histogram Adjustment.

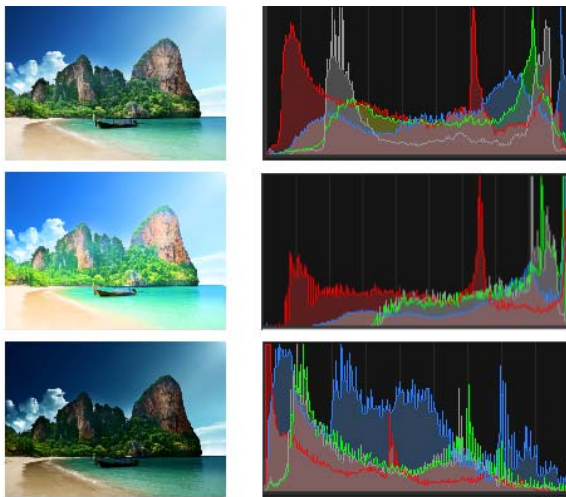

*Example of histograms (right) for three different exposures.*

Note the following when you look at a histogram:

- The left portion of the histogram reveals how much of the photo is black or nearly black.
- The right portion of the histogram reveals how much of the photo is white or nearly white.

The graph in the Histogram Adjustment dialog box displays the number of pixels for each value of the selected channel. The vertical

axis represents the number of pixels and ranges from zero to the highest number of pixels in the graph. The horizontal axis represents the value of the selected channel, from 0 to 255.

You can display a Histogram for an image at any time by choosing **View ▶ Palettes ▶ Histogram**.

## To change brightness or contrast

Edit workspace

- 1 Choose **Adjust ▶ Brightness and Contrast ▶ Brightness/Contrast**.

The Brightness/Contrast dialog box appears.

- 2 Type or set a value in the **Brightness** control.

A positive number lightens the photo; a negative number darkens the photo. A value of zero preserves the original setting.

- 3 Type or set a value in the **Contrast** control.

A positive number increases contrast; a negative number decreases contrast. A value of zero preserves the original setting.

- 4 Click **OK**.



You can use the zoom control in the dialog box to set your view of the image in the Before and After panes.

## To brighten dark areas and adjust clarity

Edit workspace

- 1 Choose **Adjust ▶ Brightness and Contrast ▶ Fill Light/Clarity**.

The Fill Light/Clarity dialog box appears.

- 2 Type or set a value in the **Fill Light** control.

A positive number lightens the darkest areas of the photo; a negative number darkens the light areas of the photo. A value of zero preserves the original setting.

- 3 Type or set a value in the **Clarity** control.



A positive number increases detail; a negative number decreases detail and focus. A value of zero preserves the original setting.

- 4 Click **OK**.

## To enhance depth and clarity

Edit workspace

- 1 Choose **Adjust ▶ Brightness and Contrast ▶ Local Tone Mapping**.

The Local Tone Mapping dialog box appears.

- 2 Type or set a value in the **Strength** control.

Use the smallest value that produces a satisfying result. Values that are too high cause unwanted artifacts to appear in the photo.

- 3 Click **OK**.



You can use the zoom control in the dialog box to set your view of the image in the Before and After panes.

## To change color channel brightness

Edit workspace

- 1 Choose **Adjust ▶ Brightness and Contrast ▶ Curves**.

The Curves dialog box appears.

- 2 In the **Channel** drop-list, select one of the following color channel options:

- **RGB** — lets you edit the red, green, and blue channels in a combined histogram
- **Red** — lets you edit the red channel only
- **Green** — lets you edit the green channel only
- **Blue** — lets you edit the blue channel only

- 3 Drag points on the graph to adjust the relationship between the input levels (the brightness of the original pixels) and the output levels (the brightness of the corrected pixels).

As you drag a curve point, the point's original and modified values for pixel lightness are displayed in the upper-left corner of the histogram graph. The original or input value appears on the left), and the modified or output value appears on the right.

4 Click **OK**.

### You can also

Add a point to the curve	Click where you want to add the point to the curve. <b>Note:</b> Adding more points to the curve lets you adjust its shape more precisely.
Remove a curve point	Drag the point to the left or right off the graph.
Move the active curve point more precisely	Press or hold down the <b>Arrow</b> keys.
Automatically adjust the photo's contrast	Click the <b>Contrast</b> button in the <b>Auto</b> group box. <b>Note:</b> You can use this button when you're satisfied with the photo's colors but want to improve the contrast.
Automatically adjust the photo's white balance	Click the <b>Color</b> button in the <b>Auto</b> group box. <b>Note:</b> You can use this button to find a black point and a white point in the photo automatically.
Automatically adjust both the contrast and the color	Click the <b>Levels</b> button in the <b>Auto</b> group box.

## You can also

---

Set your own black, gray, or white point	Click the black, gray, or white dropper in the <b>Colors</b> group box to activate the dropper color. Then, move the cursor into the Before pane and click what you know to be a black, gray, or white point. The After pane (and the image window if the <b>Preview on Image</b> check box is marked) is updated.
Automatically determine the appropriate black, gray, or white point	Hold down <b>Alt</b> , and position the cursor in the Before pane (or in the image window). As you move the cursor over dark, medium, and light areas, the appropriate color dropper becomes active. Click to set that point.
Specify histogram clipping limits for the <b>Auto Contrast</b> , <b>Color</b> , and <b>Levels</b> buttons	Click the <b>Options</b> button. In the Auto Color Options dialog box, set percentage values for the <b>Lower Limit</b> and <b>Upper Limit</b> controls, and for the <b>Strength</b> control. Note: For the <b>Lower Limit</b> and <b>Upper Limit</b> controls, higher values result in stronger automatic settings, and lower values result in weaker automatic settings. Lower <b>Strength</b> values result in less clipping.
Reset all modified values to the original values	Click the <b>Reset</b> button located near the Colors droppers. You can also click the <b>Reset to Default</b> button located next to the <b>Save Preset</b> button.

---



You can use the zoom control in the dialog box to set your view of the image in the Before and After panes.

## To adjust a photo's highlights, midtones, and shadows

Edit workspace

- 1 Choose **Adjust** ▶ **Brightness and Contrast** ▶ **Highlight/Midtone/Shadow**.

The Highlight/Midtone/Shadow dialog box appears.

- 2 Choose one of the following options:
  - **Absolute adjustment method** — sets the absolute positions of the 25% histogram point (Shadows), the 50% histogram point (Midtones) and the 75% histogram point (Highlights). Typical values are about 35 for Shadow, 50 for Midtone, and 65 for Highlight, but they vary, depending on the photo. Increasing the value lightens the region, and decreasing the value darkens the region.
  - **Relative adjustment method** — adjusts the lightness levels relative to their original states. Positive values lighten the region, and negative values darken it.
- 3 Type or set values in the **Shadow**, **Midtone**, and **Highlight** controls.
- 4 Click **OK**.



You can use the zoom control in the dialog box to set your view of the image in the Before and After panes.

## To correct exposure by using the histogram

Edit workspace

- 1 Choose **Adjust** ▶ **Brightness and Contrast** ▶ **Histogram Adjustment**.

The Histogram Adjustment dialog box appears.

2 In the **Edit** group box, choose one of the following options:

- **Luminance** — lets you set the lightness values of the image to correct contrast
- **Colors** — lets you choose a color channel to edit

If you choose the **Colors** option, you must choose a color from the drop-list.

3 In the **Load Preset** drop-list, choose **Default**.

The default values represent no adjustment to the image.

4 Adjust the **Low** slider.

On the left side of the histogram, look for a gap between the left edge and the point where the graph starts to rise. A gap shows that the darkest pixels in the image are not completely black. Drag the **Low** slider (the black triangle) to the point where the graph rises. The **Low** control displays the low position (from 0 to 254). The bottom control displays the percentage of pixels that are between zero and the low value; contrast for these pixels will be lost. As a general rule, keep the **Low** value lower than 0.1%.

5 Adjust the **High** slider.

On the right side of the histogram, look for a gap between the right edge of the window and the point where the graph decreases to zero pixels. If there is a gap, drag the **High** slider (the white triangle) to that point on the graph. This action changes the lightest pixels in the image to white. As a general rule, keep the **High value** lower than 0.1%.

6 Adjust the **Gamma** slider.

If the overall image is too dark or too light, adjust the gamma, which is a standard measure of change in an image's contrast. To lighten the image, increase the gamma by dragging the **Gamma** slider (the gray triangle) to the right. To darken the image, decrease the gamma by dragging the **Gamma** slider to the left.

- 7 Adjust the **Midtones** slider.

**Note:** If the graph has peaks on the left and right sides and contains low points in the center, the midtones need to be compressed. Shadows and highlights must be expanded to reveal the information they contain. Photography subjects that are too close to the camera appear brightly illuminated against a dark background. To compress the midtones, drag the **Midtones** slider up.

If the graph peaks in the center and has a low number of pixels at the left and right sides, expand the midtones by dragging the **Midtones** slider down.

- 8 Click **OK**.



You can create artistic effects by using the **Output Max** and **Output Min** controls on the left side of the histogram. The **Max** slider is the white circle within a gray square; the **Min** slider is the black circle within a gray square. To darken the image's lightest pixels, drag the **Max** slider down. To lighten the image's darkest pixels, drag the **Min** slider up. Even though you are dragging sliders along the vertical axis, the **Max** and **Min** values (from 0 to 255) affect the horizontal axis. All pixels outside the range are converted so that they fall within the range. You can choose another color component from the **Edit** drop-list and make similar adjustments.

## To distribute lightness across a photo

Edit workspace

- Choose **Adjust** ▶ **Brightness and Contrast** ▶ **Histogram Equalize**.

## To increase contrast by stretching the histogram

Edit workspace

- Choose **Adjust** ▶ **Brightness and Contrast** ▶ **Histogram Stretch**.



The **Histogram Stretch** command pulls the darkest pixel down to black and the lightest pixel up to white. This command does not affect images that already span from pure black to pure white. If the original image has pixels that are very close to black and white, using this command will have a very small effect. If the original image is very flat (nothing close to black or white), using this command will have a strong effect.

## To adjust brightness, contrast, and gamma simultaneously

Edit workspace

- 1 Choose **Adjust ▶ Brightness and Contrast ▶ Levels**.

The Levels dialog box appears.

- 2 In the **Levels** group box, choose the color channel to adjust from the **Channel** drop-list:
  - **RGB** — lets you edit the red, green, and blue channels in a combined histogram
  - **Red** — lets you edit the red channel only
  - **Green** — lets you edit the green channel only
  - **Blue** — lets you edit the blue channel only
- 3 Adjust the black, gray, or white diamond sliders, or set values in the controls beneath them.
  - To darken the darkest pixels in the photo, drag the black diamond slider to the right (or set a value in the numeric control).
  - To adjust the photo's midtones, drag the gray (middle) diamond to the left or right (or set a value in the numeric control).
  - To lighten the lightest pixels in the photo, drag the white diamond slider to the left (or set a value in the numeric control).

**Note:** To see which pixels are being clipped as you drag either the black or white diamond slider, hold down **Ctrl** as you drag. The After pane displays the clipped colors.

4 Click **OK**.

## You can also

---

Automatically adjust the photo's contrast

Click the **Contrast** button in the **Auto** group box.

**Note:** You can use this button when you're satisfied with the photo's colors but want to improve the contrast.

---

Automatically adjust the photo's white balance

Click the **Color** button in the **Auto** group box.

**Note:** You can use this button to find a black point and a white point in the photo automatically.

---

Automatically adjust both the contrast and the color

Click the **Levels** button in the **Auto** group box.

---

Set your own black, gray, or white point

Click the black, gray, or white dropper in the **Colors** group box to activate that dropper color. Then, move the cursor into the Before pane (or into the image window), and click what you know to be a black, gray, or white point. The After pane (and the image window if the **Preview on Image** check box is marked) is updated.

---

Automatically determine the appropriate black, gray, or white point

Hold down **Alt**, and position the cursor in the Before pane (or in the image window). As you move the cursor over dark, medium, and light areas, the appropriate color dropper becomes active. Click to set that point.

---



## You can also

---

Specify histogram clipping limits for the **Auto Contrast**, **Color**, and **Levels** buttons

Click the **Options** button. In the Auto Color Options dialog box, set percentage values for the **Lower Limit** and **Upper Limit** controls and for the **Strength** control.

**Note:** For the **Lower Limit** and **Upper Limit** controls, higher values result in stronger automatic settings, and lower values result in weaker automatic settings. Lower **Strength** values result in less clipping.

---

Reset all modified values to the original values

Click the **Reset** button located near the **Colors** droppers.

You can also click the **Reset to Default** button located next to the **Save Preset** button.



Changes you make in the Auto Color Options dialog box are applied when you use the **Contrast**, **Curves**, and **Levels** buttons in the **Auto** group box of the **Curves** dialog box.



You can use the **Levels** command to spread out the histogram for a photo taken with an improper exposure. You may find it helpful to use this command before using the **Curves** command.

You can use the zoom control in the dialog box to set your view of the image in the Before and After panes.

## To convert a photo's pixels to black and white

Edit workspace

- 1 Choose **Adjust** ▶ **Brightness and Contrast** ▶ **Threshold**.

The Threshold dialog box appears.

- 2 Type or set a value for pixel lightness in the **Threshold** control to specify which pixels to change to white (those above the threshold) and which pixels to change to black (those below the threshold).

Values range from 1 to 255. Lower values produce more white pixels; higher values produce more black pixels.

- 3 Click **OK**.



You can use the zoom control in the dialog box to set your view of the image in the Before and After panes.

## Adjusting hue and saturation

Saturation is the purity or vividness of a color, expressed as the absence of white. A color with 100% saturation contains no white. A color with 0% saturation corresponds to a shade of gray. A hue is the property that defines a particular color. For example, blue, green, and red are all hues.

Hue refers to the actual color (such as red or yellow). Saturation is the vividness of the color. Imagine bright orange, which is a highly saturated color. As the saturation is reduced (keeping the hue and lightness unchanged), the orange color becomes brownish, then taupe, and finally a middle neutral gray (after the saturation has been reduced to zero). Reducing the saturation drains the color away, leaving just the grayscale component. Taupe and mauve are low-saturation colors because they are quite neutral, with just a touch of color. Apple red and banana yellow are high-saturation colors. Saturation is a measure of how different a color is from a neutral gray of the same brightness.

In digital images, increasing the saturation can give the image brilliant color and “punch,” but too much saturation distorts colors and causes

problems such as unnatural-looking skin tones. You can use the Vibrancy control to target only those areas that are low on saturation without affecting the rest of the image. For example, you can boost color in less saturated parts of an image without significantly altering skin tone.

Corel PaintShop Pro gives you four ways to alter the hue and saturation of a selection or of an entire image:

- You can replace all colors with a single color and saturation while leaving the lightness values unchanged. You can create sepia tones, like the brownish tones seen in old photographs, and other single-color effects.
- You can shift all colors and change their strength and lightness. Changing the hue shifts all pixels in an image to a different point on the color wheel. For example, if you change the red pixels to green, the green pixels turn to blue, and the yellow pixels turn to cyan. Adjusting the saturation changes the amount of gray in a color. (The level of gray increases as the saturation decreases.) Adjusting the lightness changes color brightness.
- You can replace one or more colors. For example, you can shift all greens to blues. You can also change the saturation or the lightness. When you adjust these values, all colors (both original and shifted colors) are adjusted.
- You can adjust only the least saturated colors in the image using the Vibrancy control and thus leave unaltered those pixels that are already relatively saturated. The result is that you will get a general improvement in the saturation in the colors of an image but not to the extent where colors become unrealistically bright. The Vibrancy control is recommended for adding saturation to portraits as it offers some protection for skin tones and is less likely to oversaturate and destroy the subject's skin color.

## To create a duotone photo

Edit workspace

- 1 Choose **Adjust** ▶ **Hue and Saturation** ▶ **Colorize**.

The Colorize dialog box appears.

**Note:** To create a duotone with more subtle color changes, do the following before choosing the Colorize command: Choose **Image** ▶ **Greyscale**, and then choose **Image** ▶ **Increase Color Depth** ▶ **RGB - 8 bits/channel**.

- 2 Type or set values in the following controls:
  - **Hue** — specifies the hue to which all current colors are changed
  - **Saturation** — specifies the saturation of the selected hue
- 3 Click **OK**.

## To adjust hue, saturation, and lightness

Edit workspace

- 1 Choose **Adjust** ▶ **Hue and Saturation** ▶ **Hue/Saturation/Lightness**.
  - The Hue/Saturation/Lightness dialog box appears. The outer color ring in the dialog box represents the original values of colors in the image. The adjusted values will appear on the inner color ring.
- 2 In the **Edit** drop-list, do one of the following:
  - To edit all colors simultaneously, choose **Master**.
  - To edit a specific color range, choose **Reds**, **Yellows**, **Greens**, **Cyans**, **Blues**, or **Magentas**.

If you choose to edit a color range, you can use the control ring that appears between the inner and outer color rings to modify the range to be edited. To change the range width, drag the two outer points on the control ring. To change the area in which the adjustment builds to full effect, drag the two inner bars (the full effect will be applied between the bars). To move the adjustment area, drag the white circles.

- 3 Adjust the **Hue** slider.

The **Hue** value represents the change from the original pixel color as the number of degrees of rotation around the 360-degree color wheel. A positive value indicates a clockwise rotation, and a negative value indicates a counterclockwise rotation. For example, when the **Hue** value is 180, blue becomes yellow, and green becomes magenta.

- 4 Adjust the **Saturation** slider.

Dragging the slider up increases the saturation; dragging it down decreases the saturation. Values range from -100 to 100. A value of 0 preserves the original setting.

- 5 Adjust the **Lightness** slider.

Dragging the slider up increases the lightness; dragging it down decreases the lightness. Values range from -100 to 100. A value of 0 preserves the original setting.

- 6 Click **OK**.



You can turn an image into a duotone (two-color) image by marking the **Colorize** check box, which converts the image to grayscale. To colorize the image, you can select a hue and adjust the saturation and lightness values.

## To shift colors

Edit workspace

- 1 Choose **Adjust ▶ Hue and Saturation ▶ Hue Map**.

The Hue Map dialog box appears.

**Note:** In the **Hue Shift** group box, the top row of color boxes shows 10 original colors, and the bottom row of color boxes shows the shifted colors. Each color is represented as degrees of rotation around the 360-degree color wheel.

- 2 Adjust the slider for each color that you want to shift.

- 3 Click **OK**.

## You can also

---

Change the saturation of all colors	Type or set a value from -100 to 100 in the <b>Saturation shift</b> control.
Change the lightness of all colors	Type or set a value from -100 to 100 in the <b>Lightness shift</b> control.
Reset the colors to their default settings	In the <b>Load Preset</b> drop-list, choose <b>Default</b> .

---

## To boost the color of the least saturated parts of an image

Edit workspace

- 1 Choose **Adjust ▶ Hue and Saturation ▶ Vibrancy**.

The Vibrancy dialog box appears.

- 2 Click the arrow next to Preview to open the Preview panel.

If you want to preview the result directly in the image, mark the **Preview on Image** check box.

- 3 Adjust the **Strength** slider.

Dragging the slider to the right increases the saturation of the least saturated colors while leaving highly saturated colors unaltered; dragging it to the left decreases the saturation.

Values range from -100 to + 100. A value of 0 preserves the original settings of the image.

- 4 Click **OK**.

## Adding or removing noise

The term “noise” in photography refers to unwanted single pixels or groups of pixels that do not belong in the photo. The noise can be caused various factors. Usually, the problems are either introduced electronically by the camera itself or caused by file formats such as

JPEG. Noise appears as colored specks within the photo. You can display the noise best by zooming in. For example, you might see specks of red, pink, green, and yellow in a photo of a clear blue sky.

Corel PaintShop Pro gives you many ways to remove various types of noise, and it even lets you add noise to an otherwise “clean” photo. You can make the following corrections by applying them to a selection or an entire image:

- You can reduce the detail in an image and add a grainy texture. By adding a small percentage of noise to an image, you can reduce the appearance of small imperfections and scratches that cannot be removed with other tools.
- You can find and eliminate small scratches that are either lighter or darker than the surrounding area.
- You can remedy a common problem seen in video capture images in which even- and odd-numbered scan lines are recorded at different rates. The problem is usually noticed if the subject was moving when the image was captured. Note that removing scan lines may make noise more visible.
- You can restore a JPEG image to its original appearance. When you save a file to the JPEG format from any software package (such as scanning software), the file information is compressed to create a smaller file. The compression may produce any of the following artifacts: halos or color leakage beyond the edges of objects, checkerboard patterns on smooth backgrounds, or blocky areas.
- You can remove undesirable patterns from scanned images. This problem sometimes occurs in scanned photographs printed on textured paper.

- You can remove single-pixel specks that are mostly white or black. The brightness of each pixel is analyzed and then compared to the surrounding pixels to determine whether it should be removed.
- You can remove noise in a photo without losing details in edges within the photo. For example, you can preserve the edges of facial features while correcting a blotchy complexion.
- You can remove small random specks or areas of noise that are distinctly different from the surrounding area. The intensity of each pixel is adjusted to the median intensity of surrounding pixels. (The median intensity is the middle value, not the average,) in the range of values.) To preserve object edges, you can use the Median Filter command. With this command, you can apply more adjustment to a pixel that differs greatly from surrounding pixels than to a pixel that is similar to surrounding pixels. You can specify the number of surrounding pixels to use in the calculation. If you choose a large number of pixels, more noise is removed, so more detail is lost.
- You can remove multipixel black or white specks, such as those caused by dust on film or video.
- You can remove noise or specks in an image while preserving details in textures. For example, you can preserve textures in clothing while removing noise from another area (such as a person's face).

In addition, you can use the One Step Noise Removal and the Digital Noise Removal commands. For more information, see “To remove digital noise quickly” on page 174 and “To use advanced options for removing digital noise” on page 175.

## To add noise

Edit workspace

- 1 Choose **Adjust** ▶ **Add/Remove Noise** ▶ **Add Noise**.



The Add Noise dialog box appears.

- 2 Choose a noise pattern option:
  - **Random** — creates a granular effect that adds texture
  - **Uniform** — changes the color of the noise to resemble the original pixels
  - **Gaussian** — makes most of the noise resemble the original pixels more than the **Uniform** option
- 3 Type or set a value in the **Noise** control to set the percentage of noise to add.
- 4 Click **OK**.



You can use black-and-white noise pixels by marking the **Monochrome** check box. To use colored pixels, unmark the check box.

## To remove scratches automatically

Edit workspace

- 1 Choose **Adjust ▶ Add/Remove Noise ▶ Automatic Small Scratch Removal**.

The Automatic Small Scratch Removal dialog box appears.

- 2 Mark one or both of the following check boxes:
  - **Remove dark scratches** — removes scratches that are darker than the background
  - **Remove light scratches** — removes scratches that are lighter than the background
- 3 In the **Local Contrast Limits** group boxes, type or set values in the **Lower** and **Upper** controls to set the contrast between a scratch and its background.

Increase the **Lower** control setting to just below where scratches reappear. Decrease the **Upper** control setting to just above where the scratches reappear.

- 4 In the **Strength** group box, choose an option to set the strength of the scratch removal:

- **Mild**
- **Normal**
- **Aggressive**

**Note:** Select the lowest setting that removes scratches. Examine all areas of the image to make sure that important details are not lost.

- 5 Click **OK**.



To limit the correction to a specific area, make a selection. The command works better when applied to a selection than when applied to an entire image.

## To sharpen video capture images

Edit workspace

- 1 Choose **Adjust ▶ Add/Remove Noise ▶ Deinterlace**.

The Deinterlace dialog box appears.

- 2 In either the Before or After pane at the top of the dialog box, drag to pan to the image area where the scan lines are most apparent.
- 3 In the **Scanlines to retain** group box, choose an option that specifies whether to retain the odd-numbered or even-numbered scan lines.
- 4 Click **OK**.



You should apply the Deinterlace command before you resize the image. Resizing adds or removes pixels from the image, which makes it more difficult to identify scan lines. If your image has already been resized, you must return it to the original size as closely as possible so that each scan line is 1 pixel high. Using the zoom control in the dialog box, you can zoom until you can see how many pixels make up one scan line, and then you can resize the image so that each scan line is 1 pixel high. For example, if the enlarged image has scan lines that are 2 pixels high, you would resize it by 50 percent. Note that resizing the image causes it to lose clarity.

## To remove artifacts from JPEG images

Edit workspace

- 1 Choose **Adjust ▶ Add/Remove Noise ▶ JPEG Artifact Removal**.

The JPEG Artifact Removal dialog box appears.

- 2 In either the Before pane or the After pane at the top of the dialog box, drag to pan to the image area where the scan lines are most apparent.
- 3 In the **Strength** group box, choose an option to determine the strength of correction.

**Note:** For best results, try each option, and examine all areas of the image, to see which one works best.

- 4 Type or set a value in the **Crispness** control to specify the amount of detail to restore.

Values range from 0 (the least) to 100 (the most).

**Note:** Excessive crispness may produce fine dots in the image.

- 5 Click **OK**.



You can apply the **JPEG Artifact Removal** command to a file in any format. For example, if you have saved a JPEG file to the

Corel PaintShop Pro (.pspimage) format, you can still apply the command.

Because JPEG compression discards image information, the ability to restore JPEG images is limited.

## To remove moire patterns

Edit workspace

- 1 Choose **Adjust ▶ Add/Remove Noise ▶ Moire Pattern Removal**.

The Moire Pattern Removal dialog box appears.

- 2 Type or set a value in the **Zoom** control to magnify the image until you can see the fine patterns clearly.
- 3 Type or set a value in the **Fine details** control to set the level of pattern removal.

Change the value one number at a time until the pattern disappears. Higher values may blur the image, so use the lowest value that removes the pattern.

- 4 Use the zoom control in the dialog box to reduce the image magnification until you can see bands or color blotches clearly in the After pane.

**Note:** Although bands or blotches may be visible when the image is displayed at a setting of 100%, they may be easier to see at lower settings.

- 5 Change the value one number at a time in the **Remove bands** control until any color bands or blotches become less visible (they may not disappear completely). To avoid desaturation of small objects, use the lowest value possible.
- 6 Click **OK**.



After you have removed the moire pattern, you may be able to use the **Sharpness** commands in the **Adjust** menu to restore detail and remove blurriness without reintroducing the pattern. The **Sharpness** commands work best when you choose a **Fine**

**details** setting in the Moire Pattern Removal dialog box that is slightly higher than needed to remove the pattern.

## To remove single-pixel specks

Edit workspace

- 1 Select the area in the photo that contains the specks.
- 2 Choose **Adjust ▶ Add/Remove Noise ▶ Despeckle**.  
The selection is despeckled.

## To remove noise while preserving edges

Edit workspace

- 1 Select the area that contains the noise you want to remove.
- 2 Choose **Adjust ▶ Add/Remove Noise ▶ Edge Preserving Smooth**.  
The Edge Preserving Smooth dialog box appears.
- 3 Type or set a value in the **Amount of smoothing** control.  
Choose the smallest amount of smoothing that removes the specks while retaining image detail. You cannot enter a value lower than 1.
- 4 Click **OK**.



Although you can apply the **Edge Preserving Smooth** command to the entire image, the command works best when you select the problem area.

## To remove distinct areas of noise

Edit workspace

- 1 Select the area that contains the noise you want to remove.
- 2 Choose **Adjust ▶ Add/Remove Noise ▶ Median Filter**.  
The Median Filter dialog box appears.

- 3 Type or set a value in the **Filter Aperture** control to choose the number of surrounding pixels to include in determining the median pixel intensity.

Values range from 3 to 31 in odd-numbered increments.

**Note:** To preserve image details, choose the smallest filter that removes the noise. For single-pixel colored specks, set the filter to 3.

- 4 Click **OK**.



Although you can apply the **Median Filter** command to the entire image, the command works best when you select the problem area.

## To remove multipixel specks

Edit workspace

- 1 Select the area that contains the specks.
- 2 Choose **Adjust ▶ Add/Remove Noise ▶ Salt and Pepper Filter**.  
The Salt and Pepper Filter dialog box appears.
- 3 Type or set a value in the **Speck size** control to set the minimum size, in pixels, of the largest speck that can be completely removed. The value is always an odd number.
- 4 Type or set a value in the **Sensitivity to specks** control to set how different an area must be from its surrounding pixels to be considered a speck.
- 5 Click **OK**.



Although you can apply the **Pepper Filter** command to the entire image, the command works best when you select the problem area.



You can remove all specks that are smaller than the **Speck size** value by marking the **Include all lower speck sizes** check box.

You can intensify the strength of the correction by marking the **Aggressive action** check box.

## To remove noise while preserving textures

Edit workspace

- 1 Select the area that contains the noise you want to remove.
- 2 Choose **Adjust ▶ Add/ Remove Noise ▶ Texture Preserving Smooth**. The Texture Preserving Smooth dialog box appears.
- 3 Type or set a value in the **Amount of correction** control to set a value for the strength of the correction.  
At lower values, a small amount of noise is removed, but textured areas are preserved. At higher values, more noise is removed, but textured areas may not be fully preserved.
- 4 Click **OK**.



Although you can apply the **Texture Preserving Smooth** command to the entire image, the command works best when you select the problem area.

## Controlling depth of field

You can control the depth of field to create an area of focus that draws attention to the subject in your photo. For example, in a photo of a person surrounded by a field of flowers, you can defocus (blur) the surrounding flowers while retaining a clear focus on the person.



*You can apply the Depth of Field effect to draw attention to the subject in your photo.*

In photography, depth of field refers to the area that appears to be in focus. Different factors affect the depth of field, including the distance between the camera and your subject, the lens speed, and your camera's aperture setting. Most automatic cameras use the smallest aperture setting possible to ensure that most of the image is in focus.

### **Selecting an area of focus**

In Corel PaintShop Pro, you can quickly choose an area of focus by creating a circular or rectangular selection, or you can trace around an area to create an irregularly shaped selection. You can also invert a selection. For more information about selections, see "Creating selections" on page 292.

### **Adjusting the blurred area**

You can control the amount of blur applied to the area outside the selection, and you can adjust the transition between the area in focus and the blurred areas. Corel PaintShop Pro also lets you choose



between circular or hexagonal aperture shapes. The aperture shape can affect light patterns that appear in the out-of-focus areas. This effect is called bokeh, and it is most noticeable in small pinpoints of light on a dark background.

## To create an area of focus by using the Depth of Field effect

### Edit workspace

- 1 In the Edit workspace, select the area that you want to keep in focus.

For information about selecting image areas, see “Creating selections” on page 292.

- 2 Click **Adjust ▶ Depth of Field**.

The Depth of Field dialog box appears.

- 3 Move the **Blur** slider to adjust the amount of blur applied to the out-of-focus area.

### You can also

---



Invert the selected area

Mark the **Invert** check box.

---

Control the aperture shape for the blurred area

Click one of the following buttons:

- **Circular Aperture Shape** 
- **Hexagonal Aperture Shape** 

---

Adjust the transition between the area in focus and the blurred area

Move the **Feather edge** slider. Moving the slider to the right increases the feathering; moving the slider to the left decreases the feathering. Note that a setting of **0** produces a hard, undefined edge, which is probably not what you want. In general, do not set this slider to less than **2** or **3**.

---

## You can also

Fine-tune the size of the area in focus

Move the **Focus range** slider to the left to shrink the area in focus. Move the slider to the right to expand the area in focus to the edge of the selection.



If you don't have a pre-existing selection, you can select an area of focus using any of the selection tools in the Depth of Field dialog box: **Circular** , **Freehand** , **Rectangular** , or **Raster Selection** .



Make your selection slightly larger than the area you want to keep in focus, and then fine-tune the edge of the selection by using the **Focus range** slider.

## Blurring images

Corel PaintShop Pro provides several commands that let you apply a blurring effect to your images. You can apply the following corrections to a selection, a layer, or an entire image:

- You can remove noise that occurs throughout an image by adjusting the intensity of each pixel to the average intensity of its surrounding pixels. You can also remove color dithering that results from increasing the color depth of a paletted image to 24-bit.
- You can remove noise by applying smooth transitions and decreasing the contrast in your image.
- You can adjust the strength of the blurring effect by blending a specific number of pixels incrementally, following a bell-shaped

curve. The blurring is dense in the centre and feathers at the edges.

- You can use a fixed exposure time to simulate taking a picture of a moving object.
- You can simulate a photo taken while spinning a camera in circles, or while zooming in quickly at a very slow shutter speed.

## Why would I blur an image on purpose?

You can use blurring commands to soften a selection or an image, to retouch a photo, or to remove noise in an image. The Blur commands smooth transitions and decrease contrast by averaging the pixels near the edges and near areas of significant color transitions. You can apply any of the Blur commands multiple times to the same image to increase the blurring effect.

## To apply blurring based on nearby pixel intensity

Edit workspace

- 1 Choose **Adjust ▶ Blur ▶ Average**.

The Average dialog box appears.

- 2 Type or set a value in the **Filter aperture** control.

Values range from 3 to 31 in odd-numbered increments. The higher the value, the greater the blur.

- 3 Click **OK**.

## To apply minimal blurring

Edit workspace

- Choose **Adjust ▶ Blur ▶ Blur**.



To double the effect, choose the command again.

## To apply moderate blurring

Edit workspace

- Choose **Adjust ▶ Blur ▶ Blur More**.



To double the effect, choose the command again.

## To apply Gaussian blurring

Edit workspace

- 1 Choose **Adjust ▶ Blur ▶ Gaussian Blur**.

The Gaussian Blur dialog box appears.

- 2 Type or set a value in the **Radius** control to specify the distance (radius) within which dissimilar pixels are blurred.

Values range from 0.00 to 100.00.

- 3 Click **OK**.

## To apply motion blurring

Edit workspace

- 1 Choose **Adjust ▶ Blur ▶ Motion Blur**.

The Motion Blur dialog box appears.

- 2 In the **Angle** group box, drag the angle dial, or type or set a value in the control, to set an angle from which the blurring is applied.

- 3 Type or set a value in the **Strength** control.

Values range from 1 to 100%. Lower values lessen the effect; higher values intensify the effect.

- 4 Click **OK**.

## To apply radial blurring

Edit workspace

- 1 Choose **Adjust ▶ Blur ▶ Radial Blur**.

The Radial Blur dialog box appears.

- In the **Blur Type** group box, choose one of the following options:
  - **Spin** — blurs pixels circularly around the image center
  - **Zoom** — blurs pixels away from the center
  - **Twirl** — blurs pixels in a spiraling manner. You can set the degree of the twirl by typing or setting a value in the **Twirl degrees** control.
- In the **Blur** group box, type or set a value in the **Strength** control. Lower values lessen the effect; higher values intensify the effect. If you need to squeeze the radius to fit the image, mark the **Elliptical** check box. This option produces elliptical blurring on rectangular images and has no effect on square images. Circular blurring is produced when the check box is unmarked.
- In the **Center** group box, type or set a value in the following controls to affect the center of the image:
  - **Horizontal offset %** — lets you set the horizontal center point of the blur
  - **Vertical offset %** — lets you set the vertical center point of the blur
  - **Protect center %** — lets you determine how much to diminish blurring at the image center. Higher values increase the radius of the unblurred center area.
- Click **OK**.

## Sharpening images

Most digital photos need some level of sharpening because of the softness introduced in the capturing process of digital cameras. Camera movement at the moment of capture can also produce photos in need of sharpening, and digital cameras are more prone than film cameras to producing slightly out-of-focus photos. In most cases, this problem is easy to fix.

Color, tonal, and resizing corrections tend to soften your photo, so it is best to apply any necessary sharpening before you print, share, or archive your photos.

Corel PaintShop Pro provides sharpening commands that improve blurry photos by increasing the contrast of adjacent pixels. The following sharpening commands can be applied to a selection, a layer, or the entire photo:

- You can sharpen high-frequency details, such as edges, while ignoring low-frequency details, such as large structures, gradients, and background colors.
- You can improve image focus and clarity by increasing the contrast between adjacent pixels, particularly along edges in the photo.
- You can sharpen the mid- to high-contrast edges in the image without enhancing noise, as is often done with professional color correction.

## To apply high-frequency sharpening

Edit workspace

- 1 Choose **Adjust ▶ Sharpness ▶ High Pass Sharpen**.

The High Pass Sharpen dialog box appears.

- 2 Type or set a value from 0.00 to 250.00 in the **Radius** control to specify the distance (radius) within which dissimilar pixels are sharpened.

**Note:** Photos with close-up subjects and softer details usually require higher **Radius** settings; photos with lots of fine detail usually require lower **Radius** settings.

- 3 Type or set a value from 0 to 100 in the **Strength** control to specify the overall strength of the command.

- In the **Blend mode** drop-list, choose one of the following options to determine how the high-frequency sharpened areas are blended into the original image area:
  - **Overlay** — removes the neutral tones in the image and makes edge details stand out
  - **Hard Light** — produces greater contrast than the **Overlay** option
  - **Soft Light** — produces a softer-looking photo
- Click **OK**.

## To apply minimal sharpening

Edit workspace

- Choose **Adjust ▶ Sharpness ▶ Sharpen**.



To double the effect, choose the command again.

## To apply moderate sharpening

Edit workspace

- Choose **Adjust ▶ Sharpness ▶ Sharpen More**.



To double the effect, choose the command again.

## To apply low-frequency and high-frequency sharpening

Edit workspace

- Choose **Adjust ▶ Sharpness ▶ Unsharp Mask**.

The Unsharp Mask dialog box appears.

- Type or set a value from 0.01 to 100.00 in the **Radius** control to specify the distance (radius) within which dissimilar pixels are sharpened.

**Note:** Photos with close-up subjects and softer details usually require higher **Radius** settings; photos with lots of fine detail usually require lower **Radius** settings.

- 3 Type or set a value from 1 to 500 in the **Strength** control to specify the overall strength of the command.
- 4 Type or set a value from 0 to 100 in the **Clipping** control to specify the lightness values that adjacent pixels must have in order to be sharpened.
- 5 Click **OK**.

## Softening images

Softening a photo creates a dreamy, glossy effect that mimics the effect produced by a high-quality soft-focus lens. This effect is often used for magazine covers and glamour photos. Crisp, sharp photos appear warmer when you add a soft focus.

Corel PaintShop Pro provides the following softening methods:

- You can apply a soft-focus camera lens effect to the photo or selection.
- You can apply a uniform, soft blur to the photo or selection.

### To apply a soft focus to a selection or image

Edit workspace

- 1 Choose **Adjust ▶ Softness ▶ Soft Focus**.

The Soft Focus dialog box appears.

- 2 In the **Focus** group box, type or set a value in the following controls:
  - **Softness** — determines the strength of the adjustment. At lower percentages, the photo is softened by only a small amount. At higher percentages, the photo appears blurred.
  - **Edge importance** — determines how much softening to apply to edge details within the photo. At lower percentages, the edges are softened. At higher percentages, the edge details are retained, so less softening is applied to them.



- 3 In the **Halo** group box, type or set a value in the following controls:
  - **Amount** — determines the strength of the halo effect. At lower values, the halo is added only to very bright areas in the photo. At higher values, a halo effect is created around all bright areas.
  - **Halo size** — determines the size of the halo. At lower values, the halo is small. At higher values, the halo effect is large.
  - **Halo visibility** — determines the strength of the halo visibility. At lower values, the halo effect is subtle. At higher values, the halo effect is more obvious.
- 4 Click **OK**.



You can soften bright areas in the photo's background by marking the **Include scattered light** check box.

## To apply minimal softening

Edit workspace

- Choose **Adjust ▶ Softness ▶ Soften**.

## To apply moderate softening

Edit workspace

- Choose **Adjust ▶ Softness ▶ Soften More**.

## Resizing images

After you adjust your image, you can resize it. It's important to understand how resizing affects image pixels.

### Effect of resizing on image resolution

Pixels have no set physical size. Each pixel represents one sample of a single color. When an image is resized, the number of pixels in the

image may be reduced or increased, which causes the image to be resampled. Resampling changes the file size.

Print resolution is defined as the number of pixels per inch (ppi). A higher print resolution creates smaller printed pixels and therefore a smaller printed image. A lower print resolution creates larger printed pixels and a larger printed image. Resizing can be used to do the following

- change the print resolution and print size while preserving the number of pixels and file size (no resampling)
- change the number of pixels and file size while preserving the print resolution and print size (resampling)
- change the print resolution, print size, number of pixels, and file size (resampling)

Consider these guidelines when you resize your images:

- Avoid increasing the image size by more than 125%. Doing so may cause a loss of detail and sharpness.
- Resize an image only once. If you resize the image incorrectly, undo it and try again.
- Correct and retouch images before resizing.

## Resampling methods

The **Resample** option lets you specify how pixels are changed in an image. The **Bicubic** method is the slowest method, but it usually produces the best results.

The resampling types available in Corel PaintShop Pro are described in the following table.

Resampling type	Description
Smart Size	Chooses the best algorithm based on the new pixel dimensions you set
Bicubic	Minimizes the jaggedness that often results from expanded, irregular, or complex images
Bilinear	Uses the two nearest pixels around each existing pixel to determine the appearance of newly created pixels
Pixel Resize	Duplicates or removes pixels to achieve the selected width and height of the image (recommended for hard-edged images and simple graphics)
Weighted Average	Uses a weighted-average color value of neighboring pixels to determine the appearance of newly created pixels (useful for reducing photorealistic, irregular, or complex images)

## What happens to pixels when you resample an image?

When you use the Resize command to increase the image dimensions, additional pixels must be interpolated from information in the existing pixels. Imagine that you have an image of  $100 \times 100$  pixels, and that you want to enlarge the image by increasing the number of pixels to  $200 \times 200$ . You begin with 10,000 pixels and after resizing end up with 40,000 pixels. Thus, three-fourths of the final pixels are “made up.” Most methods of making up pixels involve interpolating the interpixel gaps produced by stretching the image dimensions. The Pixel Resize method copies the color of the nearest pixel. The Bilinear method is based on an average of four neighboring pixels (from a  $2 \times 2$  pixel

neighborhood). The Bicubic method is more sophisticated and uses 16 neighboring pixels (from a  $4 \times 4$  pixel neighborhood). This larger neighborhood provides more information about how the color is changing in that particular part of the image and therefore can improve the colors in the made-up pixels.

When you use the Resize command to decrease the image dimensions, the pixel colors are averaged together. Imagine that you want to decrease an image from  $100 \times 100$  pixels to  $50 \times 50$  pixels. The result contains 2,500 pixels, which is one-fourth of the pixels used to represent the original image. The different resampling methods determine how much weight is given to the original pixels when they are averaged together.

### **Are there other ways to resize an image?**

In addition to using the Resize command, you can also change the image size by changing the canvas size, cropping the image, printing at a different size, using the Copy Special command, or using the Save for Office command.

Increasing the canvas size adds pixels at the edge of the image. Decreasing the canvas size hides pixels at the edges of the image (full layer information is kept). For more information, see “Resizing the canvas” on page 271.

Cropping an image deletes the pixels outside the selected crop area. For more information, see “Cropping images” on page 156.

You can resize an image that you add to the Print Layout workspace by dragging its selection handles. Resizing the image in this way does not change the image file, which is helpful if you want to print the image at various sizes. For more information, see “To resize an image in print layout” on page 743.

The **Copy Special** command lets you copy the image to the Clipboard in one of three sizes, depending on whether you are copying the image to print professionally, to print from your desktop, or to copy to your computer screen or an e-mail message. After copying the image to the Clipboard, you can paste the resized image in a file in another application, such as a word processor. For more information, see “Copying images into other applications” on page 87.

The **Save for Office** command provides resizing options that are similar to those provided by the Copy Special command, except that you can save the file to disk as well as specify image size and resolution. For more information, see “To save images for office applications” on page 68.

### Why are you resizing the image?

You can use the Resize dialog box more effectively if you know why you want to resize the image.

- If you want to use a very large photo on a Web page, or if you want to attach a large photo to an e-mail, you can use the **Width** and **Height** controls in the **Print Size** group box. In the **Advanced settings** area, you should ensure that the **Maintain original print size** check box is unmarked and that the **Lock aspect ratio** check box is marked.
- If you want to resize an image by a specific percentage or to specific pixel dimensions (for example, 800 × 600), you can use the controls in the **Pixel Dimensions** group box. In the **Advanced settings** area, you should ensure that the **Resample using** check box is marked.
- If you want to resize an image by changing only its resolution, you can unmark the **Resample using** check box in the **Advanced settings** area, and type or set a value in the **Resolution** control in

the **Print Size** group box. Resizing an image in this way does not change the pixel dimensions of the image.

## To resize an image by resolution or print size

Edit workspace

- 1 Choose **Image ▶ Resize**.

The Resize dialog box appears.

- 2 Mark the **Advanced settings** check box.
- 3 Unmark the **Resample using** check box.
- 4 In the **Print Size** group box, type or set values in the **Width**, **Height**, or **Resolution** controls.

You can change the units of measurement by using the drop-lists next to the **Width**, **Height**, and **Resolution** controls.

- 5 Click **OK**.

### You can also

---

Resample image pixels

Mark the **Resample using** check box, and choose a resampling method.

**Note:** Resampling changes the image's pixel dimensions and lets you change the resolution setting independently from the width and height settings.

---

## You can also

---

Sharpen the resized image

Mark the **Resample using** check box, and choose **Bicubic** from the drop-list. Set the **Sharpness** control at approximately 100 to shrink an image; or at approximately 50 to enlarge an image.

**Note:** When the **Sharpness** control is set to 0, the sharpness of the resized image does not change.

---

Preserve the brightness of the resized image

In the **Miscellaneous** options of the General Program Preferences dialog box, mark the **Preserve image brightness when resizing** check box.

---



When you unmark the **Resample using** check box, the **Width**, **Height**, and **Resolution** controls work together — a change to one control causes the other controls to change. When you use this method, the pixel dimensions of the image remains unchanged.

## To resize an image by pixel dimensions or percentage

Edit workspace

- 1 Choose **Image ▶ Resize**.

The Resize dialog box appears.

- 2 Mark the **Advanced settings** check box to display the additional Resize settings.
- 3 Mark the **Resample using** check box, and select a resampling method from the drop-list.

**Note:** The Bicubic method usually produces the best results, although it is also the slowest method.

If you want to resize the current layer only, unmark the **Resize all layers** check box.

- 4 From the drop-list in the **Pixel Dimensions** group box, choose either **Pixels** or **Percent** (to resize as a percentage of the original), and then type or set values in the **Width** and **Height** controls.
- 5 Click **OK**.



It is recommended that you constrain the new image dimensions to the image's current proportions by marking the **Lock aspect ratio** check box. Changing the aspect ratio distorts the image by stretching or contracting it in one dimension more than the other. In the **Print Size** and **Pixel Dimensions** group boxes, a lock icon appears next to the **Width** and **Height** controls when the **Lock aspect ratio** check box is marked. Changing the setting of one of these controls automatically changes the setting of the other control.



You can preserve the image's current print size by marking the **Maintain original print size** check box. When this check box is marked, a lock icon appears next to the **Resolution** control and the **Width** and **Height** controls in the **Pixel Dimensions** group box.



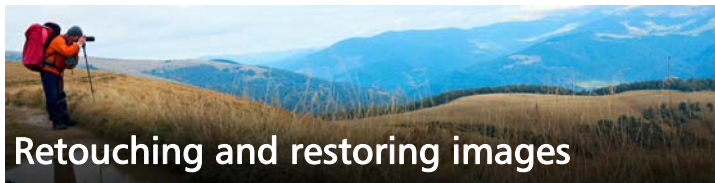

Corel PaintShop Pro provides you with many ways to retouch your images. Whether you want to remove a small scratch, erase the entire background, or simply correct red-eye, you'll find the tools you need.

This section presents the following topics:

- Removing red-eye
- Applying cosmetic changes
- Removing scratches
- Removing flaws and objects
- Using Magic Fill to erase image areas
- Erasing image areas
- Cutting out image areas
- Retouching image areas by using brushes
- Recoloring image areas for a realistic effect
- Replacing colors, gradients, or patterns
- Filling areas with colors, gradients, or patterns
- Flipping and mirroring images
- Adding borders
- Scaling photos by using Smart Carver
- Scaling and transforming photos using the Pick tool
- Resizing the canvas

## Removing red-eye

Red-eye in photos is a common problem. When light from the camera's flash reflects off the retina of a photo subject, a red-eye effect is captured in the photo. Corel PaintShop Pro has two methods of removing red-eye from a color photo.

The fastest method of removal is to use the Red Eye tool. A more powerful method is to use the advanced Red Eye Removal command, which lets you change the eye color.



*The Red Eye tool replaces the red color in the subject's pupil with a dark gray color, restoring a natural look.*

### To remove red-eye quickly

Edit workspace

- 1 On the Tools toolbar, choose the **Red Eye** tool .
- 2 On the Tool Options palette, adjust the **Size of Red-Eye** control so that the pointer is about twice the size of the red area needing correction.
- 3 Position the pointer directly over the eye, and click.



You can zoom in on the photo, if necessary, for better control of the **Red Eye** tool.

You can size the pointer interactively by holding down **Alt** while dragging the **Red Eye** tool over the eye area.

### To use advanced options for red-eye removal

Edit workspace

- 1 Choose **Adjust ▶ Red Eye Removal**.

- 2 In the After preview area, drag to center the red eyes of the subject. If necessary, use the **Zoom** control to see the eyes in more detail.
- 3 Choose a color variation option from the **Hue** and **Color** drop-lists.  
**Note:** The **Hue** drop-list is available only for the **Auto Human Eye** method.
- 4 From the **Method** drop-list, choose one of the following correction methods:
  - **Auto Human Eye** — automatically selects the correction area and chooses settings appropriate for a human eye
  - **Auto Animal Eye** — automatically selects the correction area and chooses settings appropriate for an animal eye. This method lets you rotate the selection.
  - **Freehand Pupil Outline** — lets you use the **Freehand Selection** tool to select the correction area for human or animal eyes
  - **Point-to-Point Pupil Outline** — lets you use the **Point-to-Point Selection** tool to select the correction area for human or animal eyes

When more careful correction is needed, such as for a partially obscured pupil, it is best to use the **Freehand Pupil Outline** method or the **Point-to-Point Pupil Outline** method.

- 5 In the Before preview area, perform one of the following tasks:
  - For the **Auto Human Eye** or **Auto Animal Eye** method, click inside the red area of the eye to select the eye automatically, or drag from the center of the eye to the outside edge of the red area.
  - For the **Freehand Pupil Outline** method, drag around the edge of the red area of the pupil until you reach the beginning point of the selection.
  - For the **Point-to-Point Pupil Outline** method, click around the edge of the red area of the pupil, and double-click when you

reach the beginning point. You can reverse a click by right-clicking.

After you select the eye, a circle appears around the selected area, and a control box for making adjustments encloses the circle. The After preview area displays the corrected eye.

**Note:** If you choose the **Freehand Pupil Outline** method or the **Point-to-Point Pupil Outline** method, confine the selection area to the pupil of the eye (the small dark circle at the eye's center). These methods are designed to correct the pupil area, where red-eye occurs, without changing the surrounding iris.

- 6 Set the following controls to fine-tune the red-eye correction:
  - **Pupil lightness** — specifies the amount of lightness in the pupil so that the corrected eye matches the natural eye color
  - **Iris size** — specifies the size of the iris. Increasing the iris size decreases the pupil size.
  - **Glint lightness** — specifies the lightness of the glint. Lower values darken the glint; higher values lighten it.
  - **Glint size** — specifies the size of the glint
  - **Feather** — adjusts the edges of the corrected eye so that they appear to blend into the surrounding image areas or appear more defined. Lower values make the edges more defined; higher values blend the edges into the surrounding image areas.
  - **Blur** — blends the eye with surrounding pixels when the photo has a grainy appearance. You can increase the setting one unit at a time until the eye blends naturally with the rest of the image.
- 7 Click **OK**.

## You can also

---

Move the glint to the center of the pupil    Mark the **Center glint** check box.

---

## You can also

---

Rotate a selection for an animal eye Drag the center rotation handle.

---

Reshape a selection Drag the side handles of the selection.

---

Delete a selection Click **Delete Eye**.

---



The **Refine** slider helps you correct red-eye when the eye is partially obscured in the original photo. For example, if the eyelid covers part of the eye in the original photo, it should also cover that part of the eye in the corrected photo. Dragging the slider to the left reduces the correction and minimizes its overlap with the surrounding skin.

## Applying cosmetic changes

You can quickly improve the appearance of the subjects in your photos by performing the following cosmetic changes:

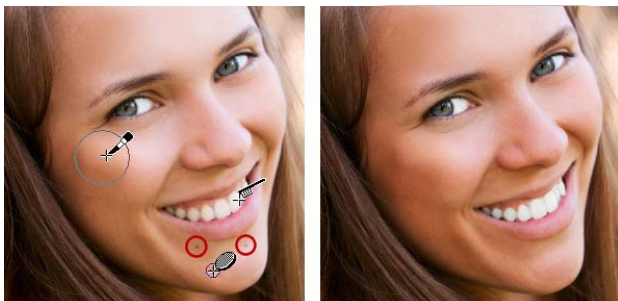

- removing blemishes — by using the **Blemish Fixer** mode of the **Makeover** tool
- whitening teeth — by using the **Toothbrush** mode of the **Makeover** tool
- fixing bloodshot eyes — by using the **Eye Drop** mode of the **Makeover** tool
- adding a suntan — by using the **Suntan** mode of the **Makeover** tool
- thinning a photo subject — by using the **Thinify** mode of the **Makeover** tool
- removing wrinkles — by using the **Scratch Remover** tool
- smoothing skin tone quickly — by using the **Skin Smoothing** command in the **Adjust** menu



*You can remove blemishes, whiten teeth, and apply a suntan.*

## To remove facial blemishes

Edit workspace



- 1 On the Tools toolbar, choose the **Makeover** tool .
- 2 On the Tool Options palette, choose the **Blemish Fixer**  mode. The pointer changes to concentric circles.
- 3 On the Tool Options palette, adjust the **Size** control to the smallest size that allows the inner circle to enclose the blemish. The outer circle is for the material used to cover the blemish.
- 4 On the Tool Options palette, adjust the **Strength** control. Values range from 1 to 100. Higher values apply more of the source material (enclosed in the outer circle) to the blemish area (enclosed in the inner circle).
- 5 Click directly over the blemish.



You can zoom in on the photo for better control of the **Makeover** tool.

## To whiten teeth

Edit workspace

- 1 On the Tools toolbar, choose the **Makeover** tool .
- 2 On the Tool Options palette, choose the **Toothbrush**  mode.
- 3 On the Tool Options palette, adjust the **Strength** control as desired.

Higher settings produce more intense whitening but may also produce an unnatural appearance.

- 4 Click directly over the teeth.



If the teeth are separated or partially obscured, you may need to apply this tool to each tooth individually.



The **Toothbrush** mode of the **Makeover** tool works only with color photos.

## To apply whitening eye drops

Edit workspace



- 1 On the Tools toolbar, choose the **Makeover** tool .
- 2 On the Tool Options palette, choose the **Eye Drop**  mode.
- 3 Type or set a value in the **Strength** control.

Higher values whiten more of the eye area but may spread the whitening beyond the affected area of the eye.

- 4 Zoom in as necessary, and then carefully click over the bloodshot portion of the eye.

## To apply a suntan



Edit workspace

- 1 On the Tools toolbar, choose the **Makeover** tool .
- 2 On the Tool Options palette, choose the **Suntan**  mode.

- 3 Type or set a value in the **Size** control.
- 4 Type or set a value in the **Strength** control.  
Higher values produce a darker tan.
- 5 Carefully drag over the skin of the photo subject.



## To apply a thinning effect

Edit workspace

- 1 On the Tools toolbar, choose the **Makeover** tool .
- 2 On the Tool Options palette, choose the **Thinify**  mode.
- 3 Type or set a value in the **Strength** control.  
Higher values compress more pixels in the horizontal axis.
- 4 Click the middle of the photo subject.  
The pixels compress on either side of the point you click. You can continue clicking to enhance the thinning effect.

## To remove facial wrinkles

Edit workspace

- 1 On the Tools toolbar, choose the **Scratch Remover** tool .
- 2 On the Tool Options palette, choose either the square edge  or the beveled edge  selection box.
- 3 Type or set a value in the **Width** control so that the wrinkle fits inside the inner portion of the selection box you drag.
- 4 Position the pointer just outside the wrinkle, and carefully drag over the wrinkle so that the wrinkle is enclosed in the inner rectangle.  
The wrinkle is covered by the surrounding skin texture.



If you need to start again, you can undo the correction, adjust the **Width** control, and redrag.



For wrinkle lines that are not straight, correct just one portion at a time.

## To smooth skin tone

Edit workspace

- 1 Choose **Adjust ▶ Skin Smoothing**.
- 2 In the Skin Smoothing dialog box, adjust the **Amount** slider. Moving the slider to the right applies more smoothing; moving the slider to the left applies less smoothing.



*The Skin Smoothing command smooths skin tones and diminishes the appearance of wrinkles and blemishes quickly.*



The **Skin Smoothing** command automatically detects and smooths skin tones without affecting eyes or lips. However, if other areas in your photo are affected because they are similar in color to the skin tone, you can use a selection to isolate the area you want to smooth. For more information about selections, see “Creating selections” on page 292.

## Removing scratches

The Scratch Remover tool lets you remove scratches, cracks, and other unwanted image areas from photos.





*You can repair individual scratches by using the Scratch Remover tool.*

You can use the tool to enclose the flawed area and fill it with the surrounding content that you want to keep. If the background is relatively smooth, the result is usually satisfying. Scratches on a textured or more complex background may be more effectively removed with the Clone Brush tool. For information about the Clone Brush tool, see “Removing flaws and objects” on page 240.

For images containing many small scratches, you can use the Automatic Small Scratch Remover command. For more information, see “To remove scratches automatically” on page 205.

## To remove scratches

### Edit workspace

- 1 On the Layers palette, select the layer that contains the area you want to remove.
- 2 On the Tools toolbar, choose the **Scratch Remover** tool .
- 3 On the Tool Options palette, choose one of the following options to define the shape of the **Scratch Remover** tool:
  - square edge  — corrects scratches that are perpendicular to object edges, in an open area, or of uniform color
  - beveled edge  — corrects scratches that are at an angle to object edges
- 4 Position the pointer just outside the scratch on one end, hold down the left mouse button, and drag to set a selection box over the scratch.
- 5 Release the mouse button.

The enclosed area is replaced with the surrounding pixels.

### You can also

---

Move the selection box starting point in 1-pixel increments

Before releasing the mouse button, press an **Arrow** key.

---

Increase or decrease the width of the selection box in 1-pixel increments

Before releasing the mouse button, press **Page up** or **Page down**.

---

Use surrounding pixels to fill the area perpendicular to the edge of the selection box

Before releasing the mouse button, press **Shift**.

This technique is ideal for photos in which the background contains areas with defined borders and lines, such as a brick wall.

---



To avoid removing important details from areas surrounding the scratch, you can limit the correction by creating a selection.

For information about creating selections, see “Creating selections” on page 292.

If you are not satisfied with the result, click the **Undo** button , reselect the scratch, and try varying the width of the tool.

If the scratch extends over several different backgrounds, you can try removing the scratch one section at a time.

## Removing flaws and objects

You can remove flaws and objects in your images by using the Clone Brush tool or the Object Remover tool. The Clone Brush tool lets you remove flaws and objects by painting over them with another part of the image. The paint source can be a part of the same layer, another layer in the image, a merged image, or a layer from another image.



*The Clone Brush tool was used to remove the cracks on the wall from the photo on the left.*

The Object Remover tool lets you remove objects when the surrounding area is fairly uniform in color and texture. This tool is similar to the Clone Brush tool in that it lets you identify the area to remove and then choose a background for covering that area.



*The Object Remover tool was used to remove one boat from the water.*

## To clone a part of an image

Edit workspace

- 1 On the Tools toolbar, choose the **Clone Brush** tool .
- 2 On the Tool Options palette, choose the brush tip, size, opacity, and other settings.

If you want the **Clone Brush** tool to reset the source point each time you resume painting, mark the **Aligned mode** check box. You can continue dragging over the target area to fill in the source image. Unmark the check box if you want every stroke to copy the same data from the original source point.

If you want to clone data from all layers merged together, mark the **Use all layers** check box. If you want to clone data from the current layer only, unmark the check box.

- 3 On the source image, right-click the center point of the source area.

If the image has more than one layer, click the name of the layer on the Layers palette before you define the source area.

- 4 Drag in the image where you want to paint the cloned area.



When you clone an image area, you must select a source area with data.

If your image contains a selection, you must right-click within the selection to set your clone source. If you are using a pen tablet, you can achieve the same result by holding down **Shift**.







You can also hold down **Shift** and click the image to set the source point.

You can resize the brush interactively by pressing **Alt** while dragging in the image window.

## To remove objects from a photo

### Edit workspace

- 1 On the Tools toolbar, choose the **Object Remover** tool .
- 2 On the Tool Options palette, choose the **Selection Mode** button .
- 3 Drag around the object that you want to remove.
- 4 On the Tool Options palette, choose the **Source Mode** button . A rectangle is displayed in the image window.
- 5 Position the rectangle over the area that will replace the previous selection.
- 6 Drag the handles on the rectangle to resize it, or drag the rotation handle on the rectangle to rotate it.  
It is recommended that you make the rectangle as large as, or slightly larger than, the area you are removing.
- 7 On the Tool Options palette, click the **Apply** button .
- 8 Choose **Selections ▶ Select None** to deselect the selection.

### You can also

---

Feather a selection made with the **Freehand Selection** tool

Before making the selection, adjust the **Feather** control on the Tool Options palette.

---

## You can also

---

Adjust the opacity of the source material

Before clicking the **Apply** button, adjust the **Opacity** control on the Tool Options palette.

---

Choose source material from all layers or from the current layer

Mark the **Use all layers** check box to choose source material from all layers as though they were merged. Do not mark this check box if you want to choose source material from the current layer only.

---

Blend edges and use the object's tonal ranges when applying the source material

Choose the **Smart Blending** option on the Tool Options palette.

---



You can also create a selection by using any of the selection tools before you activate the **Object Remover** tool.

You can deselect the selection by pressing **Ctrl + D**.

## Using Magic Fill to erase image areas

Magic Fill is a content-aware feature that can make unwanted elements of your photos vanish. Use your favorite selection tools to select an area or object that you want to remove and apply Magic Fill to replace the selection with a background that matches the surrounding area—even when the surrounding area is textured or varied. For more information about selections, see “Working with selections” on page 291.



## To erase an image area with Magic Fill

- 1 In the Tools toolbar, choose one of the following selection tools:
  - Selection Tool
  - Freehand Selection
  - **Smart Selection Brush** (unmark **Smart Edge** on the Tools Options palette so that only the areas that you brush across are selected)
- 2 On the Tool Options palette, adjust the settings you want.
- 3 In the image, select the area that you want to erase. You don't need to be precise. Magic Fill works best when some of background is included in the selection.
- 4 On the Tool Options palette, click the **Magic Fill** button .

The selected area is filled with the color and texture sampled from the background.

If you don't get the results that you expect the first time, it's easy to undo the fill and readjust the selection, or simply create a new selection and reapply Magic Fill only to the areas that you want to touch up.

## Erasing image areas

You can use the Eraser tool to erase areas of a layer to transparency. When you use the Eraser tool on a raster layer, all pixels in the tool's



path become transparent. A gray-and-white checkerboard pattern indicates transparent areas.



*You can quickly remove the background from an image by using the Background Eraser tool.*

You can use the Background Eraser tool to erase pixels selectively. For example, in a photo of a mountain range, you can erase the sky, or you can isolate an object from the surrounding image area.

### **The difference between undoing and erasing**

When you undo an action in Corel PaintShop Pro, the detail from the original image is restored. To understand the difference between undoing and erasing, consider the example of paint strokes. If you make a mistake with a paint stroke and erase it, the image detail under the stroke is lost. You can erase paint when you want to make certain pixels transparent. You can also erase to create an effect, such as when you want one layer to show through another layer.

### **Settings for the Background Eraser tool**

You can adjust the default settings for the Background Eraser tool on the Tool Options palette. For example, you can change the opacity, color tolerance, and sample area settings.

You can set the following controls when you use the Background Eraser tool:

- **Opacity** — specifies the level of opacity. A setting of 100% erases pixels to complete transparency, and a lower setting erases pixels to partial transparency.
- **Tolerance** — determines how closely the selected pixels match the sampled pixel. The range of values is 0 to 512. At lower settings, only pixels with very similar colors are erased. At higher settings, more pixels are erased. (This option is unavailable if the Auto Tolerance check box is marked.)
- **Sharpness** — specifies how much the softness of the erased edge depends on the color difference between the object and the background. The range of values is 0 to 100. You can use lower settings when the edges that you are erasing form a gradient (a more gradual color transition); you can use higher settings when the edges that you are erasing have a more abrupt color transition.
- **Sampling** — specifies the basis on which pixels are erased. This control has the following options:

**Once** — samples the point at which you first click and then erases all matching pixels for the duration of the stroke. This setting erases similar colors and preserves the areas you want to keep.

**Continuous** — samples continuously and erases all matching pixels. If the area to erase is quite variable, you can use this option and set the Step value low, so that the area is sampled frequently as you erase. The tool can erase any color it encounters, including foreground colors if the sampled pixel falls into the foreground area.

**BackSwatch** — erases all pixels that match the current background color on the Materials palette

**ForeSwatch** — erases all pixels that match the current foreground color on the Materials palette

- **Limits** — specifies whether erased pixels are adjacent to each other. This control has the following options:

**Discontiguous** — erases all pixels in the tool's path that match the sampled pixels, even if they are nonadjacent. You can use this mode to correct areas in which the background shows through holes in the image.

**Contiguous** — erases only contiguous pixels that match sampled pixels. You can use this mode when the background pixels are of a color that is similar to that of the edges of the object you want to isolate.

**FindEdges** — uses the edge information to restrict the erasing

**Auto Tolerance** — determines the tolerance based on the pixels in the tool's path. The tolerance may change continuously as the tool moves over different parts of the layer. You can unmark this check box to specify a Tolerance setting.

**Use all layers** — samples data from all layers merged together. Only pixels in the current layer are erased. To sample data from the current layer only, you can unmark the check box.

**Ignore Lightness** — ignores sharp differences in color lightness and saturation. You can mark this check box when the colors in the object that you want to isolate are strongly saturated and the background is unsaturated, or vice versa.

## Should I use automatic or manual tolerance?

You should start by marking the Auto Tolerance check box. If you find that too much or too little is erased from the image, you can unmark the Auto Tolerance check box and increase or decrease the value in the Tolerance box.

## To erase an image area

Edit workspace

- 1 On the Tools toolbar, choose the **Eraser** tool .
- 2 On the Tool Options palette, choose the brush options you want.  
For more information about setting brush options, see “Choosing brush options” on page 595.
- 3 Drag in the image to erase.

### You can also

---

Restore erased pixels	Hold down the right mouse button, and drag over the erased area.
Erase a straight line	Click at the beginning of the line, hold down <b>Shift</b> , and click the end of the line. To continue erasing the line, move to the next point, hold down <b>Shift</b> , and click again.

---



If you erase the background layer, the Eraser tool erases to transparency, and the layer is automatically promoted to a raster layer.

## To erase the background area of an image

Edit workspace

- 1 On the Layers palette, click the layer that contains the image element that you want to isolate.
- 2 On the Tools toolbar, choose the **Background Eraser** tool .
- 3 On the Tool Options palette, choose the brush options you want.  
For more information about setting brush options, see “Choosing brush options” on page 595.
- 4 Drag around the edges of the image area that you want to isolate.

Slow, careful strokes give you the best results. Keep the center of the brush on regions you want to erase, while keeping the edges of the brush on regions you want to preserve.

## You can also

Restore erased pixels	Right-click and drag.
Erase a straight line	Click once at the beginning point, hold down <b>Shift</b> , and click the endpoint. To continue erasing the line, move to the next point, hold down <b>Shift</b> , and click again.
Switch to the <b>Eraser</b> tool	Hold down the <b>Backspace</b> key while you drag the mouse.



The background layer is automatically promoted to a raster layer when you work on it with the **Background Eraser** tool.



You can preserve the transparent background (when you want to place the visible content on another layer or background) by saving your file in the following file formats: PSPIImage, PNG, GIF.

## Cutting out image areas

You can use the Object Extractor to cut out an image area from the surrounding background. You can then edit the cutout separately from the background, display it against a different background, or combine it with other images.

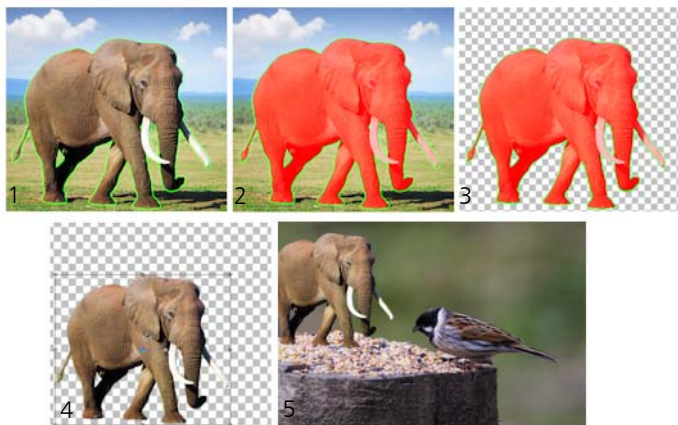

*Object Extractor workflow: (1) Outline the edges of the image area; (2) add a fill; (3) preview the cutout, and touch it up if necessary; (4) bring the cutout into the image window; (5) place the cutout against a different background image (optional).*

## To cut out an image area

Edit workspace

- 1 On the Layers palette, click the layer that contains the image area that you want to cut out.
- 2 Choose **Image ▶ Object Extractor**.

The **Object Extractor** dialog box appears, with the **Brush** tool  activated by default.

- 3 Adjust the brush size by moving the **Brush size** slider.
- 4 In the preview area, draw a line along the edges of the image area that you want to cut out.

Ensure that the selection outline slightly overlaps the surrounding background and completely surrounds the area in a closed ring.

- 5 Choose the **Fill** tool , and click inside the area you want to cut out.



An overlay covers the image area that you clicked.

**Note:** If the selection outline is not closed, the fill covers the entire image. If this is the case, click the **Eraser** tool  to clear the fill, and then complete the selection outline with the **Brush** tool.

- 6 Click **Process** to preview the result.

If you are not happy with the result, click **Edit Mask** to return to the previous view and touch up the cutout.

## You can also

Erase parts of the selection outline	Choose the <b>Eraser</b> tool  , and drag over the selection marquee that you want to delete.
Refine the edge detail in the final result	Move the <b>Accuracy</b> slider to a higher value if the object has an intricate or complex outline. The <b>Accuracy</b> slider is available only after you click <b>Process</b> .
Revert to the original image	Click <b>Reset</b> . The <b>Reset</b> button is available only before you click <b>Process</b> and clears both the fill and the selection outline.
Hide the fill overlay and the edge outline	Mark the <b>Hide Mask</b> check box.
Specify an exact size for the brush or eraser nib	Type or set a value in the <b>Brush size</b> box.
Zoom in and out	Type or set a value in the <b>Zoom</b> box.
Display an image at its actual size	Click the <b>Zoom to 100%</b> button  .
Display an image in the entire preview area	Click the <b>Fit Image to Window</b> button  .

## You can also

---

Pan to another area of the image      Using the **Pan** tool , drag the image until the area you want to see is visible.

---





The background layer is automatically promoted to a raster layer when you use the Object Extractor command.



You can switch from the **Brush** tool to the **Eraser** tool by right-clicking and dragging in the preview area.









## Retouching image areas by using brushes

You can retouch images by applying brushstrokes. Some retouch brushes mimic photographic effects, while others change pixels based on their lightness, saturation, hue, or color values. Some retouch brushes create effects that are similar to those produced with the color-correction commands. The retouch brushes are described in the following table.

Brush	Effect
Lighten/Darken 	Increases or decreases brightness; affects the RGB or Lightness value of pixels
Dodge 	Lightens and brings out details of areas that are in shadow (mimics the traditional photographic darkroom technique of holding back light to produce lighter areas in printed photos)
Burn 	Darkens areas of the image that are too light

---



Smudge 	Spreads color and image details from the starting point and picks up new color and image details as it moves, as though smearing paint
Push 	Spreads color and image details from the starting point but does not pick up any new color or image details
Soften 	Smooths edges and reduces contrast
Sharpen 	Heightens edges and accentuates contrast
Emboss 	Causes the foreground to appear raised from the background by suppressing color and tracing edges in black
Saturation Up/Down 	Increases or decreases saturation; affects the HSL value of pixels
Hue Up/Down 	Increases or decreases hue; affects the HSL value of pixels
Change to Target 	Changes pixels based on a characteristic of the current foreground color on the Materials palette: color, hue, saturation, or lightness <ul style="list-style-type: none"> <li>• If you choose the color as the target, the brush applies the foreground color without affecting the luminance.</li> <li>• If you choose the hue, saturation, or lightness as the target, the brush applies the hue, saturation, or lightness value of the foreground color without changing the other values.</li> </ul>

## To use a retouch brush



Edit workspace

- 1 On the Tools toolbar, choose a retouch brush.
- 2 On the Tool Options palette, set the brush controls.
- 3 Drag in the image to apply the tool.





### You can also

### On the Tool Options palette

Reverse the tool behavior

Mark the **Swap mouse button** check box when using the Lighten/Darken , Saturation Up/Down , or Hue Up/Down  tools.

Retouch data from all layers

Mark the **Use all layers** check box when using the Smudge , Push , Soften , Sharpen , or Emboss  tools.

Lighten or darken an image with the **Lighten/Darken**  tool based on the lightness or RGB values

Choose **RGB** or Lightness from the **Mode** drop-list.

Choose a characteristic of the foreground color to target with the

Choose an option from the **Mode** drop-list.

**Change to Target** tool 

Apply brush strokes only to specific areas that match the brush stroke sample area

Mark the **Smart Edge** check box.

Limit the changes to shadows, midtones, or highlights with the

Choose an option from the **Limit** drop-list.

**Dodge**  and **Burn**  tools



For more information about setting brush options, see “Choosing brush options” on page 595.



You can apply the opposite effect of a retouch brush by right-clicking as you apply the brush to the image.

## Recoloring image areas for a realistic effect

You can use the Color Changer tool to realistically recolor an object or a region in an image. What sets the Color Changer tool apart from other tools and commands (such as the Flood Fill tool, some of the retouching brushes, or the Colorize, Hue/Saturation/Lightness, or Hue Map commands) is that it takes into account the shading of the specified color. The Color Changer tool detects and analyzes variations in image brightness and applies the recoloring based on that illumination.

It lets you adjust Tool Options palette settings for Tolerance and Edge Softness, and it updates the current recoloring as you modify settings on the Tool Options palette or modify the color in the Materials palette.



The Color Changer tool works best on matte objects such as clothing, carpet, and painted objects that are a solid color. It may not work as well on shiny or reflective objects and is not designed to work with gradients or patterns.



*One click can change the color of the girl's dress.*

## To recolor by using the Color Changer tool

Edit workspace

- 1 On the Tools toolbar, choose the **Color Changer** tool .  
The **Color Changer** tool is grouped with the **Flood Fill** tool.
- 2 On the Materials palette, click the **Color** button  on the **Style** drop-list, and choose a solid color.  
If the Materials palette is not displayed, choose **View ▶ Palettes ▶ Materials**.  
For realistic-looking colors, set the **Saturation** value (in the Material Properties dialog box) closer to 100 than to 255 (full saturation).
- 3 Position the **Color Changer** pointer over the color you want to change in the image, and then click to recolor with the Foreground/Stroke color, or right-click to recolor with the current Background/Fill color.
- 4 Click **Apply** to set the color change on the object.

## You can also

---

Use a color from the current image	Choose the <b>Dropper</b> tool  , click the color you want in the image, and then choose the <b>Color Changer</b> tool to reactivate it.
Instantly change the color you want to apply	Before clicking <b>Apply</b> , click a color on the Materials palette.
Adjust the color application	Before clicking <b>Apply</b> , adjust any of the following controls on the Tool Options palette: <ul style="list-style-type: none"><li>• <b>Tolerance</b> — determines how closely the current color needs to match similar colors for recoloring to be applied. Higher settings cause more pixels to be recolored.</li><li>• <b>Edge Softness</b> — determines how pixels that border the recolored pixels are affected. Higher settings cause more “bleeding” of the recoloring.</li></ul>

---



While using the Color Changer tool, you can undo and redo actions such as adjusting colors or adjusting settings on the Tool Options palette.



To isolate the area you want to recolor, you can create a selection. For more information about creating selections, see “Creating selections” on page 292.

To prevent the Color Changer from affecting areas of the photo that you do not want to change, you can duplicate the layer on which the photo resides, apply the Color Changer to the new layer, and use the Eraser tool to erase the areas of changed color that you want to restore. You can then merge the layers.

## Replacing colors, gradients, or patterns

You can use the Color Replacer tool to replace one color in a selection or layer with another color. You can use brushstrokes to replace only those pixels that the brush touches, or you can replace all pixels of a certain color in a selection or layer.

You can set a tolerance value so that the Color Replacer tool changes within a given color value range. The Color Replacer tool also works with gradients and patterns.

You can also use the Flood Fill tool to replace all pixels of a certain color in a selection or a layer. For information about the differences between the Color Replacer tool and the Flood Fill tool, see “Filling areas with colors, gradients, or patterns” on page 260.

### Why does nothing happen when I apply the Color Replacer tool?

You must select a foreground or background color that appears in the image. If there are no pixels that match your selected color, then no pixel colors are replaced.

For more information about picking a foreground or background color directly from the image, see “Choosing colors from an image or the desktop” on page 394.

### To replace a color, gradient, or pattern

Edit workspace

- 1 On the Tools toolbar, choose the **Color Replacer** tool .
- 2 Choose the material (color, gradient, or pattern) that you want to replace. Click the material to apply it as the Foreground/Stroke, or right-click the material to apply it as the Background/Fill.

- 3 Choose a material to use as a replacement material. The replacement material can be any material in the current image, or you can choose one from the Materials palette.
  - If the material you want to replace is the current Foreground/Stroke material, right-click the replacement material to set it as the Background/Fill.
  - If the material you want to replace is the current Background/Fill material, click the replacement material to set it as the Foreground/Stroke.
- 4 In the **Tolerance** box, set a value from 0 to 200 to specify how closely the replacement material should match the material you are replacing.

At lower **Tolerance** settings, only pixels with very similar colors are replaced; at higher settings, more pixels are replaced.

- 5 Position the cursor over the area of a selection or layer that contains the material you want to replace, and perform a task from the following table.

<b>To</b>	<b>Do the following</b>
Swap all occurrences of a background or foreground material	Double-click to swap the Background/Fill material with the Foreground/Stroke material; double-click the right mouse button to swap the Foreground/Stroke material with the Background/Fill material.
Replace all matching pixels with the current Foreground/Stroke material	On the Tool Options palette, click the <b>Replace all pixels</b> button  .

To	Do the following
Replace materials by using brushstrokes rather than replacing all pixels in the layer	On the Tool Options palette, choose the brush tip, size, opacity, and other options. Drag in the image to replace the Background/Fill material with the Foreground/Stroke material; drag with the right mouse button to replace the Foreground/Stroke material with the Background/Fill material.



To limit changes to a specific area, make a selection in the image before using the **Color Replacer** tool.

## Filling areas with colors, gradients, or patterns

You can fill a selection or a layer with the foreground or background color, gradient, or pattern. You can fill all pixels or fill only those pixels that match the options you specify. When you click in the image, the Flood Fill tool finds and fills all contiguous pixels that match the pixel you select.

Contiguous pixels are like continuous chains of matching pixels radiating from the initial pixel you click. When the Flood Fill tool finds a pixel that does not match the selected pixels, the chain breaks. Even if a pixel is only one pixel away from a matching pixel, it is treated as discontinuous.

### What is the difference between the Flood Fill tool and the Color Replacer tool?

The Flood Fill tool can fill pixels that match certain criteria (such as RGB value); in this way, it is similar to the Color Replacer tool.



The Flood Fill tool fills matching pixels that are contiguous to the initial pixel you click, whereas the Color Replacer tool changes pixels either within its brushstrokes or in the entire layer.

The Color Replacer tool changes the color of pixels based on RGB value. The Flood Fill tool changes pixels based on RGB, hue, brightness, or opacity values.

## To fill an area with a color, gradient, or pattern

Edit workspace

- 1 On the Tools toolbar, choose the **Flood Fill** tool .
- 2 Choose the foreground or background color, gradient, or pattern with which to fill the area.
- 3 From the **Match Mode** drop-list on the Tool Options palette, choose one of the following options:
  - **None** — fills all pixels
  - **RGB Value** — fills pixels that match the red, green, and blue values of the pixel you click
  - **Color** — fills pixels that match the shading variations of the pixel you click
  - **Brightness** — fills pixels that match the perceptual lightness value of the pixel you click
  - **Perceptual** — fills pixels that match the perceptual shading variation and lightness of the pixel you click
  - **Traditional** — fills pixels that match red, green, and blue values, with a bias toward lightness variations. This match mode is therefore more discriminating than the RGB Value match mode.
  - **All Opaque** — fills all pixels that are not completely invisible (that is, having an opacity value of 1 or greater). Choosing this option disables the **Tolerance** control.

- **Opacity** — fills pixels that match the opacity value of the pixel you click
- 4 Type or set a value from 0 to 200 in the **Tolerance** control to specify how closely the selected pixels match the initial pixel you click.

At lower settings, only pixels with very similar colors are filled; at higher settings, more pixels are filled.
  - 5 Choose an option from the **Blend Mode** drop-list to specify how filled pixels are blended with pixels of underlying layers.

The blend modes are the same as the layer blend modes.
  - 6 Type or set a value in the **Opacity** control to specify the opacity of the fill.

At 100 percent opacity, the paint covers everything; at 1 percent opacity, the paint is almost completely transparent.
  - 7 Position the cursor over the area of the selection or image that you want to fill, and either click to fill with the foreground material or right-click to fill with the background material.



To limit changes to a specific area, make a selection in the image before you apply the Flood Fill tool. For information about selections, see “Working with selections” on page 291.

You can limit the flood fill to matching pixels of the current layer only by unmarking the **Use all layers** check box.

For more information about using blend modes, see “Blending layers” on page 350. For more information about choosing brush options, see “Choosing brush options” on page 595.

## Flipping and mirroring images

You can flip or mirror an image so that the left side becomes the right side or the top becomes the bottom. When you choose Flip, layers or

selections are flipped in position. When you choose **Mirror**, layers or selections are flipped along their horizontal (left to right) or vertical (top to bottom) axis.

## To flip a selection, layer, or image

Edit workspace

- Click **Image > Flip**, and choose one of the following:
  - **Flip Horizontal** — the left side switches to the right side
  - **Flip Vertical** — the top switches to the bottom



Flipping a selection converts it into a floating selection, leaving the original layer unchanged.

## To mirror a selection or layer

- Click **Image > Mirror**, and choose one of the following:
  - **Mirror Horizontal** — flips the selection or layer along the horizontal axis (left to right)
  - **Mirror Vertical** — flips the selection or layer along the vertical axis (top to bottom)

## Adding borders

You can add a colored frame or border around an image. When you add a border to an image, the dimensions of the image are expanded to the border.

For multilayer images, Corel PaintShop Pro prompts you to flatten the image before adding the border; however, you can also add a border without flattening the image by changing the canvas size. For more information, see “Resizing the canvas” on page 271.



*It's easy to add a border around your image.*

## To add a border to an image

Edit workspace

- 1 Choose **Image** ► **Add Borders**.

The Add Borders dialog box appears.

- 2 Do one of the following:

- To create an equal-width border on all sides, mark the **Symmetric** check box.
- To create borders of varying widths, unmark the **Symmetric** check box, and set border width values in the controls in the **Size In Pixels** group box.

- 3 Click the **Color** box to choose a color for the border.
- 4 Click **OK**.



You can change the units of measurement for the border by choosing an option from the drop-list in the **Original Dimensions** group box.

## Scaling photos by using Smart Carver

Smart Carver lets you make a photo narrower, wider, shorter, or longer without distorting the content. By automatically detecting and removing zones in the picture that have little structural detail, this feature lets you change the aspect ratio without noticeably changing the image. You can also target a specific zone to remove from the photo, regardless of its level of detail, or preserve specific objects or image areas.





*Smart Carver lets you selectively remove or protect areas when you scale an image.*

### To remove or preserve an object by using Smart Carver

Edit workspace

- 1 Choose **Image** ▶ **Smart Carver**.

The Smart Carver dialog box opens.



- 2 To remove or preserve an object or area from a photo, do one or both of the following:
  - Click the **Remove** button  and apply the **Remove** brush to the areas of the photo that you want to remove.
  - Click the **Preserve** button  and apply the **Preserve** brush to the area of the photo that you want to protect.

In the **Object Removal** area, you can move the **Brush Size** slider to the left to decrease the size of the brush, or to the right to increase the size of the brush.

- 3 Scale the photo by applying one or more of the Smart Carving options.

## You can also

---

Delete brushstrokes	Click the <b>Eraser</b> button  , and apply it to the brushstrokes that you want to erase.
Zoom in or out	In the <b>Zoom</b> box, enter a magnification level, or use the slider or the arrows to adjust the zoom level.
Pan to view hidden areas of the photo	Click the <b>Pan</b> button  , and drag in the preview area.
Hide the brushstrokes in the preview area	Mark the <b>Hide Mask</b> check box.
Reset the photo to its original state	Click <b>Reset</b> .







---

## To scale a photo by using Smart Carver

Edit workspace

- 1 Choose **Image ▶ Smart Carver**.  
The Smart Carver dialog box opens.
- 2 In the Smart Carving area, perform one or more tasks from the following table, and click **OK**.

You can view the scaling results in the preview area.

To	Do the following
Set a photo width	Type or set a value in the <b>Width</b> box. <b>Note:</b> The maximum width is double the width of the original photo.
Set a photo height	Type or set a value in the <b>Height</b> box. <b>Note:</b> The maximum height is double the height of the original photo.
Reduce the photo width by 1-pixel increments	Click the <b>Contract the image horizontally</b> button  until the image is the desired width.
Reduce the photo height by 1-pixel increments	Click the <b>Contract the image vertically</b> button  until the image is the desired height.
Increase the photo width by 1-pixel increments	Click the <b>Expand the image horizontally</b> button  until the image is the desired width.
Increase the photo height by 1-pixel increments	Click the <b>Expand the image vertically</b> button  until the image is the desired height.
Reduce the photo width by automatically removing the areas to which you have applied the <b>Remove</b> brush	Click the <b>Auto-contract horizontally</b> button  to remove red-painted areas.
Reduce the photo height by automatically removing the areas to which you have applied the <b>Remove</b> brush	Click the <b>Auto-contract vertically</b> button  to remove red-painted areas.

## Scaling and transforming photos using the Pick tool

The Pick tool lets you transform images interactively in the following ways:

- Scaling resizes an image horizontally, vertically, or proportionally.
- Shearing skews an image vertically or horizontally.
- Distorting an image stretches or contracts it in any direction.
- Applying perspective to an image corrects the perspective or applies a false perspective. For information about correcting image perspective, see “Correcting photographic perspective” on page 164.
- Rotating an image moves it around a pivot point. For information about rotating images, see “Rotating images” on page 154.

When you transform an image, the transformations are applied to the layer on which the image resides. You can apply transformations to any raster layer or selection.

### Setting scaling and transformation options

You can precisely control many of the deform settings. The following options appear on the Tool Options palette when the Pick tool is active:

- **Pivot X, Pivot Y** — sets the X and Y coordinates of the rotation pivot point
- **Position X, Position Y** — sets the X and Y coordinates of the top left corner handle
- **Scale X (%), Scale Y (%)** — sets the percentage of change for the horizontal (X) and vertical (Y) resizing
- **Shear** — sets the offset of a side. Positive values shear to the right, and negative values shear to the left.
- **Angle** — sets the rotation around the pivot point. The image is rotated clockwise, from 0 to 360 degrees.
- **Reset Rectangle** button  — resets the deformation rectangle to its original shape but keeps any current deformations



- **Perspective X, Perspective Y** — adjusts the perspective of the deformation

**Note:** The best way to create and adjust perspective is by dragging the control handles. When you create a perspective effect with the control handles, you manipulate many variables. Changing the values in the Perspective X and Perspective Y controls may affect the scale, shear, and position values.

***Important!** The Pick tool works on grayscale and 16 million–color images only. For more information about increasing the color depth of an image, see “Increasing the color depth of an image” on page 632. For more information about deforming vector objects or text, see “Sizing, shaping, and rotating vector objects” on page 571 or “Sizing and transforming text” on page 549.*

## To scale or transform a selection, layer, or image

Edit workspace

- 1 Choose a selection, layer, or image by clicking its name on the Layers palette.
- 2 On the Tools toolbar, choose the **Pick** tool . A bounding box with handles appears.
- 3 Perform one or more tasks from the following table.

To	Do the following
Resize while keeping the current proportions	Drag a corner handle.
Resize while changing the current proportions	Right-click and drag one of the corner or edge handles.
Change the center of rotation	Drag the rotation pivot point.
Rotate the image	Drag the rotation handle.
Change perspective symmetrically	Hold down <b>Ctrl</b> , and drag a corner handle horizontally or vertically.

To	Do the following
Change perspective asymmetrically	Hold down <b>Ctrl + Shift</b> , and drag a corner handle horizontally or vertically.
Shear the image	Hold down <b>Shift</b> , and drag a side handle.
Distort the image	Hold down <b>Ctrl + Shift</b> , and drag a side handle.



By default, you must hold down **Ctrl + Shift** to distort an image. To distort an image without holding down keys, choose a different **Mode** setting on the Tool Options palette. The **Scale** mode is the default setting, so you must hold down a key or keys. The **Shear** mode lets you shear without holding down **Shift**. The **Perspective** mode lets you change perspective without holding down **Ctrl**. The **Free** mode lets you distort without holding down **Ctrl + Shift**.



When the **Pick** tool is active, you can scale and transform precisely by setting values in any of the boxes on the Tool Options palette.

## Resizing the canvas

The image canvas is the work area of the image and defines the image dimensions — for example, 200 × 300 pixels. If you need more space to add elements to an image, you can increase the canvas size, or you can resize the canvas to make it smaller.

If you want to resize by adjusting the image size, see “Resizing images” on page 221.

### What is the difference between reducing the canvas size and cropping an image?

Reducing the canvas size is not always the same as cropping an image. For images with layers, reducing the canvas size does not delete the pixels outside the new canvas area — it just shows less of the layer. Background layer information is always deleted, even when there are other layers in the image.

### To change the canvas size

Edit workspace

- 1 Choose **Image ▶ Canvas Size**.

The Canvas Size dialog box appears.

- 2 In the **New Dimensions** group box, mark the **Lock aspect ratio** check box.
- 3 Set or type values in the **Width** and **Height** controls.
- 4 In the **Placement** group box, click a button to set the placement of the image in the new canvas, or set values in the **Top**, **Bottom**, **Left**, and **Right** controls.

The values show the amount of canvas added or subtracted from each edge.

- 5 Click **OK**.



If you increase the canvas size, you can choose a color for the added canvas area by clicking the **Background** box and choosing a color.

You can resize the height and width independently by unmarking the **Lock aspect ratio** check box, and setting values in the **Height** and **Width** controls.

You can change the units of measurement for the border by choosing an option from the drop-list in the **New Dimensions** group box.



When you combine two or more photos, you can achieve some impressive results. What can you do?

- Use HDR (high dynamic range) Exposure Merge to create a perfectly exposed image.
- Seamlessly replace unwanted areas (cars, people, birds that flew into your frame) with the correct background.
- Creatively combine elements from multiple photos into one image.

If you have a DSLR camera, you likely have features that can help you take multiple photos of the same scene.

This section presents the following topics:

- Understanding HDR
- Taking photos for HDR processing
- Combining photos by using HDR Exposure Merge
- Using Single RAW Photo to create an HDR effect
- Merging batches of photos into HDR images
- Combining photos with Photo Blend

## Understanding HDR

In photography, HDR refers to “high dynamic range”. Dynamic range is the range of luminance that can be captured in a photo, from the darkest shadows to the brightest highlights.

Unlike the human eye, digital camera sensors (or film in traditional cameras), can only capture a limited dynamic range when photographing scenes with both very bright and very dark areas, such as an interior with a large window. HDR processing creates a 32-bit image which has twice as much information, and therefore many more steps between tones, than an ordinary JPG. This HDR image is then evenly exposed, resolving details in the darkest areas, without losing definition in the brightest areas. And when pushed beyond the “corrective” boundaries, HDR can produce an unreal, plastic, or even “hyper-real” tone, and as such has become a creative technique in itself. Typically, an HDR file needs to be converted back to a 16-bit image format for final output.



*The photos along the top were taken with different exposure levels, and then they were combined to create a single beautifully exposed image.*

## Taking photos for HDR processing

If you are new to HDR processing, the information below can help you get started.

### What camera features work well with HDR?

You can use automatic exposure bracketing if your camera offers it or use the aperture priority mode and adjust the shutter speed to achieve different exposures. Avoid aperture changes because the depth of field may shift enough to cause blurring in some of the photos. Review the user manual for your camera for information about bracketing options and aperture priority mode.

## How many photos should I take for my HDR set?

Usually, three photos is a good base (minimum is two), but to capture a very high contrast scene, take five or more (up to a maximum of nine).

## What exposure settings should I use?

Try an initial setting of 2.0 exposure value (EV) between photos. If you are taking a greater number of photos, you can set the exposure at lower increments, but make sure that the number of shots is enough to cover a wide range of exposure. If you're using auto-bracketing, your camera might limit the EV interval (sometimes to a maximum of +/- 1.0).

## Should I use a tripod?

Yes, it's best to use a tripod, but at the very least, you need to ensure that you have a steady hand (for example, stabilized against a wall). Using a tripod means that you are less likely to have alignment issues with the photos when you use HDR processing.

## Combining photos by using HDR Exposure Merge

You can use Exposure Merge to combine two or more photos by using HDR (high dynamic range) processing.



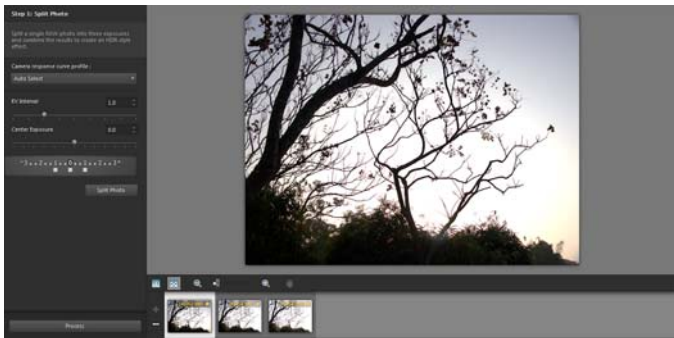

*Exposure Merge (Step 1 window)*

For more information about taking photos that work well with Exposure Merge, see “Taking photos for HDR processing” on page 275.

Exposure Merge uses a three-step process:

- **Merge** — Choose your merge settings, and if required, apply custom editing.
- **HDR Adjustments** — After merging your photos, you can adjust them and save the results to an editable HDR file before finalizing the merge and fine-tuning.
- **Fine-Tune** — Refine your image, with noise-reduction and sharpening options, along with some other familiar tools from the Adjust workspace. When you’re done, you can save to a standard file format and close Exposure Merge.

Please see the topics below for more detailed information about each step.

## Step 1: Merge

Merge settings include:

- **Camera response curve profile** — applies a curve adjustment to the image, based on the known characteristics of the sensor in your camera
- **Alignment** — Choose between **Feature-based** (detects features in the photos) or **Edge-based** (detects edges within the photos).
- **Custom editing** — Choose which areas you want to keep (Brush in) or remove (Brush out) from each photo. Often, custom editing is applied to remove “ghosting” — the semitransparent effect caused by merging photos that captured moving objects.

## Step 2: HDR Adjustments

After you merge your photos, you can adjust the resulting HDR image by applying a preset, customizing a preset, or creating the look you want from scratch. The key is to experiment. You can save your custom settings as a new preset. You can manage your presets by saving, loading, deleting or resetting them.

All the adjustment options in the HDR Adjustments window let you work on an HDR, 32-bit file. You can save the HDR file with all settings, so you can reopen and modify it again in the future. When you are finished with Step 2 and move to Step 3, the final step, the application prepares the image for output by saving it to a 16-bit image.

## Step 3: Fine-Tune

The final step is fine-tuning the merged image before you exit Exposure Merge. The controls in the Fine-Tune window are based on the controls in the Adjust workspace. For more information, see “Using the Adjust workspace” on page 139.

Some fine-tuning tips:

- **Digital Noise Removal** is a great tool for cleaning up noise that can result from merging photos.

- **High Pass Sharpen** can help reduce blurred areas that may result from movement between photos.
- **Smart Photo Fix** and **White Balance** let you tweak the colors.
- To brighten the entire image, try adjusting **Brightness/Contrast**. To brighten only the dark areas, try **Fill Light/Clarity**.
- **Local Tone Mapping** and **Fill Light/Clarity** can be used to further enhance details in the image.

## To choose merge options for Exposure Merge (Step 1)

- 1 In the Manage workspace, select the thumbnails for the photos that you want to merge.

An orange outline appears around the thumbnails of selected photos.

- 2 Click **File ▶ HDR ▶ Exposure Merge**.

- 3 In the Step 1: Merge window, choose a profile from the **Camera response curve profile** drop-list.

If you are not sure what to choose, select **Auto Select**.

If the **EV interval** slider appears, set the exposure value that you used between photos.

- 4 In the Alignment area, choose an alignment type from the **Method** drop-list.

If you want to crop any edges that don't overlap, mark the **Auto crop** check box.

- 5 Click **Align**.

To see the results, enable the **Preview Alignment** check box (near the bottom of the panel).

- 6 If you want to keep or remove specific areas from individual photos, use the controls in the Custom editing area. See "To brush in or brush out artifacts in Exposure Merge" on page 280.

## 7 Click **Process**.



The merge settings are applied and the Step 2: HDR Adjustments window appears.

If you want to tweak your merge settings, click **Back** to return to the Step 1 window.



HDR Exposure Merge and Photo Blend are part of the same merge utility and therefore cannot be opened simultaneously. If your photos were not taken with a tripod or steady rest, there is likely some misalignment between shots. If the misalignment is significant, you may not be able to use the photos for HDR.



You can also add photos to or remove photos from the merge tray by clicking the **Add Photos** button  or **Remove Photos** button  in the tray at the bottom of the Exposure Merge window.

## To brush in or brush out artifacts in Exposure Merge

- 1 In the tray that appears below the Step 1: Merge preview area, click a thumbnail.
- 2 In the Custom editing area, do any of the following:
  - Click **Brush in**, and in the preview area, drag over the area that you want to preserve. You don't need to be exact.
  - Click **Brush out**, and in the preview area, and drag over the area that you want to remove.
  - Click **Auto brush** if you want the application to auto-detect and remove ghosting. Auto brush works well for removing ghosting along feature edges in photos taken without a tripod. It is not recommended for larger ghost objects, such as cars and people.
- 3 Repeat the process for each of the photos that you want to edit.

## You can also

Change the brush size	Drag the <b>Brush size</b> slider.
Refine or erase brushstrokes	Click <b>Eraser</b> , and drag across a brushstroke in the preview area.
Remove all brushstrokes	Click <b>Clear</b> .
Change the color of brushstrokes	Click the arrow beside the <b>Brush in</b> or <b>Brush out</b> color swatch and click a new color.
Hide or display brushstrokes in the preview area	Mark or unmark the <b>Show brushstrokes</b> check box.

## To adjust HDR images in Exposure Merge (Step 2)



- 1 In the Step 2: HDR Adjustments window, do any of the following to achieve the look you want.
  - In the Presets area, click a preset thumbnail.
  - Mark the **White Balance** check box, click **Auto** or click the **Dropper tool** , and click the image to set the white point. Drag the **Temperature** slider to warm or cool the colors in the image and drag the **Tint** slider to fine-tune the color.
  - Drag the **Contrast**, **Highlights**, **Midtones**, and **Shadows** sliders to adjust the overall tone and contrast.
  - Drag the **Vibrancy** slider to saturate or desaturate the colors.
  - From the Detail drop-list, choose **Natural detail** or **Creative detail**, and drag the respective sliders to adjust the amount of local detail.

If you want to focus on black-and-white processing, click the **B&W** tab below the presets area. To re-enable color processing, click the **Color** tab.

- 2 To save your HDR image for further editing, click **Create HDR file**, navigate to the folder you want, type a file name, and click **Save**. This saves the image content. You can also save your adjustments as a preset.
- 3 Click **Process**.  
The settings are applied to the image and it is saved as a 16-bit file in preparation for the final output. The Step 3: Fine-Tune window appears.

## To manage presets in Exposure Merge

- In the Presets area of the Step 2: HDR Adjustments window, perform a task from the following table.

To	Do the following
Save your adjustments as a preset	Click the <b>Save Preset</b> button  , and type a name in the Save Preset dialog box. A thumbnail is added to the preset area.
Import a preset file	Click the Preset Options button  , click <b>Load</b> , and navigate to the file.
Delete a preset	Click the thumbnail for the preset, click the Preset Options button, and click <b>Delete</b> .
Restore the default presets list	Click the Preset Options button and click <b>Reset</b> . Click <b>Yes</b> in the confirmation dialog box. All custom presets are deleted.
Hide or display presets	Click the arrow  on the <b>Presets</b> bar.

## To fine-tune and save an HDR-processed image (Step 3)

- 1 In the Step 3: Fine-Tune window, apply any of the tools or adjustment options to adjust the final image.
- 2 Do one of the following:
  - Click **Edit** to open the file in the Edit workspace if you want to continue editing the photo. The Exposure Merge window remains open.
  - Click **Save and close** to save the file, close Exposure Merge, and return to the workspace you were last using.



When the size of a zoomed-in image exceeds that of the preview area, you can click the Pan tool  and move the rectangle to choose a preview area.

## Using Single RAW Photo to create an HDR effect

You can split a single RAW photo into three exposures and recombine the exposures to create an HDR effect. Although this is not “true” HDR (you aren’t extending the tonal range by combining multiple photos), you can still optimize the tonal range of a single photo with powerful HDR tools.

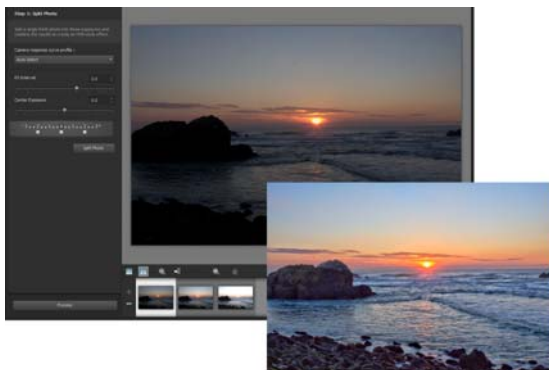

*Single RAW Photo was used to create an HDR effect to optimize the tonal range of the photo.*

### To create an HDR effect by using Single RAW Photo

- 1 In the Manage workspace, select the thumbnail of a RAW photo. An orange outline appears around the thumbnail of the selected photo.
- 2 Click **File** ► **HDR** ► **Single RAW Photo**.
- 3 In the Step 1: Split Photo window, choose a profile from the **Camera response curve profile** drop-list.  
If you are not sure what to choose, select **Auto Select**.
- 4 Drag the **EV Interval** slider to set the simulated exposure interval. This value is used to split the photo into three versions.



If you don't want the middle exposure to be set at 0, drag the **Center Exposure** slider to set a new value.

- 5 Click **Split Photo** to break the photo into three versions. Three thumbnails appear in the tray.
- 6 If you're happy with the results, click **Process**.

You can now optimize the photo using the HDR controls in the Step 2 and Step 3 windows. For more information, see "To adjust HDR images in Exposure Merge (Step 2)" on page 281 and "To fine-tune and save an HDR-processed image (Step 3)" on page 283.

## Merging batches of photos into HDR images

If you use auto-bracketing on a regular basis, you may accumulate many sets of photos that can be processed as HDR (high dynamic range) images. You can use the Batch Merge feature to quickly merge each of your bracketed sets into HDR images. You can then evaluate which sets make good candidates for the more powerful HDR tools in the Exposure Merge feature. In some cases, Batch Merge might be the only HDR processing you need to do.

Batch Merge organizes photos into sets, based on the time between photos (within a defined timeframe) or a defined number of photos per set.

### To merge batches of photos into HDR images

- 1 In the Manage workspace, select the thumbnails for the photos that you want to merge.

An orange outline appears around the thumbnails of selected photos.

- 2 Click **File ▶ HDR ▶ Batch Merge**.

The photos are sorted into groups of three by default.

- 3 In the Presets area, click a thumbnail to set a processing style. For more information on presets, see “To manage presets in Exposure Merge” on page 282.

If you want the application to perform the standard HDR processing instead of applying preset adjustments, skip this step.

- 4 Click the folder icon beside the **Save processed files in** box, and browse to the folder where you want to save the processed files.

- 5 Choose a file type from the **Save as** drop-list.

If you choose JPEG, drag the **JPEG quality** slider to set the file size and quality for the processed images.

If you want to save .hdr versions of the processed files (so you can edit them in Exposure Merge), mark the **Save .hdr file** check box.

- 6 In the **Group photos by** drop-list, choose one of the following:
  - **Sets** — lets you choose a number in the **Photos per set** box. This option works well if you consistently shoot bracketed photos in predetermined batches.
  - **Time** — lets you choose a time interval in the **Seconds per group** box. This option works well if you vary the number of photos in a bracketed set.
- 7 If the photos were taken without a tripod, enable the **Auto-align** check box and choose an alignment option from the **Method** drop-list.

If you want to crop unaligned edges along the borders of the photos, mark the **Auto crop** check box.

- 8 Click **Process**.

Processing might take a few moments, depending on the size and number of photos.

You can now navigate to the location where you saved your process files and evaluate them.



To remove thumbnails from the Batch Merge window, select the photos and press **Delete**.

## Combining photos with Photo Blend

Photo Blend lets you combine two or more photos of the same scene and choose exactly what you want to keep or remove from the scene. Here are some examples:

- Remove moving objects, such as people or cars, from a photo — you can create an empty street in a busy city.
- Fix a group shot in which one person blinks or looks away — simply swap in a better pose from another photo.
- Get creative by showing the same person multiple times in a single photo.



*Photo Blend can be used to create perfect group shots.*

## How do I take photos that work with Photo Blend?

From a tripod or with a steady rest, shoot two or more photos a few seconds apart. Use the same camera settings for all the photos.



**Photo Tip:** Use the manual setting on your camera to ensure that the photos have the same size, aperture, shutter speed, and ISO.

## To use Photo Blend

- 1 In the Manage workspace, select the set of photos that you want to blend.
- 2 Click **File ▶ Photo Blend**.
- 3 In the Alignment area, click **Align**.

To see the results, enable the **Preview Alignment** check box (near the bottom of the panel).

If you want to crop unaligned edges along the borders of the photos, mark **Auto crop**.

- 4 Click a thumbnail in the tray.  
The corresponding photo displays in the preview area.
- 5 In the **Custom editing** area, do any of the following:
  - Click **Brush in**, and in the preview area, drag over the area that you want to preserve. You don't need to be exact.
  - Click **Brush out**, and in the preview area, drag over the area that you want to remove.
  - Click **Auto brush** if you want the application to auto-detect the differences between the images. Leave the brushmarks as they are to remove ghosting and other differences, or use it as a starting point for custom brushstrokes.

- Enable the **Include moving objects** check box, and click **Auto brush** to auto-detect and preserve the differences between photos (for example, if you want to create a multi-pose image).
- 6 Repeat the editing process for other photos by clicking thumbnails in the tray and applying brushstrokes.
  - 7 Click **Process**.  
Review the results in the preview area. If you want to adjust your settings or continue editing, click **Back**.
  - 8 In the Step 2: Fine-Tune window, use any of the tools or adjustment controls to fine-tune the image. For more information, see “Using the Adjust workspace” on page 139.
  - 9 Do one of the following:
    - Click **Edit** to open the file in the Edit workspace if you want to continue editing the photo. The Photo Blend window remains open.
    - Click **Save and close** to save the file, close the Photo Blend window, and return to the workspace you were last using.

## You can also

Change the brush size	Drag the <b>Brush size</b> slider.
Refine or erase brushstrokes	Click <b>Eraser</b> , and drag across a brushstroke in the preview area.
Remove all brushstrokes	Click <b>Clear</b> .
Change the color of brushstrokes	Click the arrow beside the <b>Brush in</b> or <b>Brush out</b> color swatch and click a new color.
Hide or display brushstrokes in the preview area	Unmark or mark the <b>Show brushstrokes</b> check box.



For best results, in the tray of the Step 1 window, click the thumbnail of the image that will change the least, and click the lock button  to use the selected image as background. To unlock the background, click the lock button again.



Selecting the parts of images to edit is an important step in your workflow. By creating a selection, you can edit an area while leaving the rest of the image unchanged. You can use drawing or painting tools to modify selected areas of your image. You can also apply commands to flip, copy, crop, or perform other actions on the selected areas.

The border of a selection is identified by a selection marquee, which is a series of black and white dashes that outlines the selection.

This section presents the following topics

- Creating selections
- Hiding and displaying the selection marquee
- Moving, clipping, and rotating selections
- Modifying selections
- Inverting and clearing selections
- Using feathering with selections
- Using anti-aliasing with selections
- Modifying the edges of selections
- Creating custom patterns from selections
- Saving and loading selections



## Creating selections

You can create a selection when you want to isolate part of an image. For example, you can use a selection to adjust or retouch one area of a photo, or to copy a portion of a photo and paste it into another photo. The way you make a selection depends on whether you are working on a raster layer or a vector layer.





*You can create a selection by using a Selection tool shape (left), by creating a freehand selection (center), or by using the Magic Wand tool to select specific areas of color or opacity (right).*

The following selection tools can be used to create raster selections:

- **Auto Selection** tool  — lets you create a smart selection by enclosing an image area in a rectangle that automatically snaps to the edges it detects.
- **Smart Selection Brush**  — lets you create a selection by brushing over a sample area. The selection expands automatically to the edges based on the information that is sampled by the brush.



- **Selection tool**  — lets you create a selection of a specific shape, such as a rectangle, square, ellipse, circle, or star.
- **Freehand Selection tool**  — lets you create a selection around the edges of an object, such as petals of a flower or fingers on a hand. You can make four types of selections with the Freehand tool:
  - **Edge Seeker** — finds the edges between two areas with color differences when you click on the edges of irregularly shaped areas
  - **Freehand** — lets you quickly select an area by dragging
  - **Point to Point** — lets you draw straight lines between points to create a selection with straight edges
- **Smart Edge** — automatically finds the edges of irregularly shaped areas when you click along the edges
- **Magic Wand tool**  — makes a selection based on the color, hue, brightness, or opacity of an object. This tool is designed to select an area that has distinctly different pixels than those in other areas of an image — for example, a pink rose surrounded by green leaves, or a dark area in an otherwise bright image.

The selection tools can also be used on vector layers to create selections from vector objects. For example, if you copy a selection and paste it as a new image, it is copied to a raster layer as individual pixels rather than as a vector object.

For information about vector text, see “Applying text” on page 531.

You can make a selection with one tool and then switch to another tool to add to or subtract from the selection. For more information, see “Modifying selections” on page 307.

You can also use the Paint tool to create a selection. For more information, see “Working with brushes” on page 593.

You can use text selections to apply effects to text; for example, when you create a text selection on a solid-color layer and then delete the selection, the letters appear transparent and outlined with the layer’s solid color.

By creating a raster selection on a vector object, you can use raster-only tools and commands to edit the vector object.

You can create a selection from a mask, which lets you omit the masked (black) areas and select the non-masked (non-black) areas. The selection is clipped to the canvas. For more information, see “Working with masks” on page 369.

## To create a selection by using the Auto Selection tool

Edit workspace

- 1 On the Tools toolbar, choose the **Auto Selection** tool .
- 2 Drag across the image to enclose the area that you want to select.
- 3 Release the mouse button to view the auto-selection.

If you want to redo the selection, press **Ctrl + D** and reselect an area. If you want to refine the selection, on the Tools toolbar, choose another selection tool, and add or remove areas from the auto-selection.



## To create a selection by using the Smart Selection Brush

Edit workspace

- 1 On the Tools toolbar, choose the **Smart Selection Brush** .
- 2 On the Tool Options palette, adjust the **Size** setting. You can also adjust any of the following settings:
  - **Mode** — specifies whether to replace, add, or remove an existing selection. **Replace** is the default setting.
  - **Feather** — softens the edges of a selection by specifying a fade width (0 to 200 pixels)
  - **Anti-alias** — applies a smooth edge to a selection by making the pixels along its edges semitransparent
  - **Use all layers** — searches for an edge in all layers of the selected area. This option is available when you enable Smart Edge on multilayer images.
- 3 Drag the brush across the image area that you want to select. You don't need to be precise; the selection expands automatically to the edges based on the image information that is sampled by the brush.

- 4 Release the mouse button to review the smart selection.

If you want to refine the selection, you can press **Shift** and drag to add to the selection or press **Ctrl** and drag to remove from the selection.



You can use the Smart Selection Brush in manual mode by unmarking the **Smart Edge** check box on the Tool Options palette.

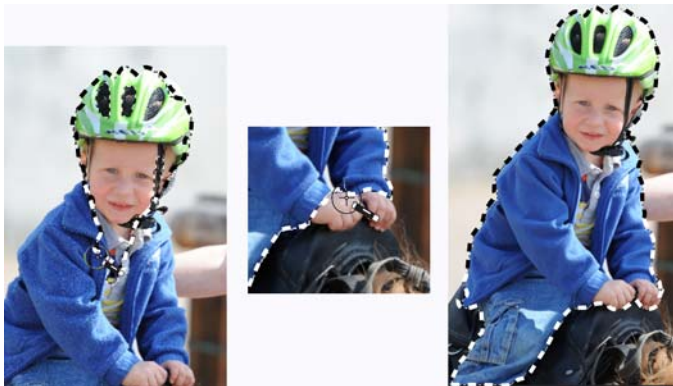

*Drag the Smart Selection Brush across the area that you want to select (left). If required, refine the selection in Add mode or unmark Smart Edge and brush over the areas precisely (center) to add or remove areas (right).*

## To create a selection by using the Selection tool

Edit workspace





- 1 On the Tools toolbar, choose the **Selection** tool .
- 2 Check the settings of the following controls on the Tool Options palette, and modify them if necessary:
  - **Selection Type** — specifies the shape of the selection area

- **Mode** — specifies whether to replace, add, or remove an existing selection. **Replace** is the default setting.
- **Feather** — softens the edges of a selection by specifying a fade width (0 to 200 pixels)
- **Anti-alias** — applies a smooth edge to a selection by making the pixels along its edges semitransparent

### 3 Drag to make the selection.

As you drag, a border indicates the selection. When you finish dragging, the selection's border becomes a selection marquee.

## You can also

Create a selection of a specific size	On the Tool Options palette, click the <b>Custom Selection</b> button  . In the Custom Selection dialog box, specify the selection position, in pixels, for the left, top, right, and bottom edges.
Replace an existing selection by placing a rectangular selection around it	Choose the <b>Selection</b> tool, and click the <b>Current selection</b> button  .
Create a rectangular selection around all nontransparent areas of the current layer	Click the <b>Layer opaque</b> button  .
Create a rectangular selection around all nontransparent areas of all layers within the image	Click the <b>Merged opaque</b> button  .



After you create a selection, changes to the settings on the Tool Options palette apply to the next action, not to the current selection. You can modify the options for the current selection by choosing **Selections ▶ Modify** and choosing a command from the menu.

## To create a selection by using the Freehand Selection tool

### Edit workspace

- 1 On the Tools toolbar, choose the **Freehand Selection** tool .
- 2 On the Tool Options palette, choose one of the following from the **Selection Type** drop-list:
  - **Edge Seeker**
  - **Freehand**
  - **Point to Point**
  - **Smart Edge**
- 3 Check the settings of the following controls on the Tool Options palette, and modify them if necessary:
  - **Feather** — softens the edges of a selection by specifying a fade width (0 to 200 pixels)
  - **Smoothing** — specifies the amount of smoothing to apply to the selection border
  - **Anti-alias** — applies a smooth edge to a selection by making pixels semitransparent
  - **Use all layers** — searches for an edge in all layers of the selected area. This option is available when you use the Edge Seeker or the Smart Edge selection type on multilayer images.
- 4 Depending on the selection type you chose, perform a task from the following table.

To	Do the following
Make a Freehand selection	Drag to select an image area.
Make an Edge Seeker selection	Click precisely along the edge of the area you want to select, and double-click or right-click to complete the selection.

To	Do the following
Make a Smart Edge selection	Click along the edge of the area that you want to select, ensuring that the rectangular cursor encloses the edge. Double-click or right-click to complete the selection.
Make a Point to Point selection	Click around the area you want to select, and double-click or right-click to complete the selection.



When making an Edge Seeker selection, you can set the distance used to search for an edge by typing a value in the **Range** control on the Tool Options palette.

You can increase the accuracy of Edge Seeker and Smart Edge selections by clicking more frequently along the edge you are following.

You can delete a previous point by pressing **Delete**.

## To create a selection by using the Magic Wand tool

Edit workspace

- 1 On the Tools toolbar, choose the **Magic Wand** tool .
- 2 On the Tool Options palette, choose a **Match mode** option:
  - **None** — selects all pixels
  - **RGB Value** — selects pixels that match the red, green, and blue values of the pixel you click
  - **Color** — selects pixels that match the shading variations of the pixel you click
  - **Brightness** — selects pixels that match the perceptual lightness value of the pixel you click
  - **Perceptual** — selects pixels that match the perceptual shading variation and lightness of the pixel you click

- **Traditional** — selects pixels that match red, green, and blue values, with a bias toward lightness variations. This match mode is therefore more discriminating than the RGB Value match mode.
  - **All Opaque** — selects all pixels that are not completely invisible (that is, having an opacity value of 1 or greater). Choosing this option disables the **Tolerance** control.
  - **Opacity** — selects pixels that match the opacity value of the pixel you click.
- 3 Check the settings of the following controls on the Tool Options palette, and modify them if necessary:
- **Tolerance** — controls how closely the selected pixels match the pixel you click in the image. At low settings, only similar pixels are chosen; at high settings, a wider range of pixels is selected.
  - **Feather** — softens the edges of a selection by specifying a fade width (0 to 200 pixels)
  - **Use all layers** — searches for matching pixels across all layers in the image
  - **Contiguous** — selects only pixels that connect to the pixel you click
  - **Anti-alias** — produces a smooth-edged selection by partially filling in pixels along the edge, making them semitransparent. You can use this option inside or outside the selection marquee.
- 4 Click the image area that contains the pixels you want to match. The selection marquee surrounds all matching pixels.



You can change the number of pixels you select by undoing the selection, adjusting the **Tolerance** setting, and making a new selection.



## To create a selection by using a Painting tool

Edit workspace

- 1 Choose **Selections ▶ Edit Selection**.

A selection layer is added to the Layers palette.

- 2 Select a painting tool from the Tools toolbar.
- 3 Choose settings for the painting tool on the Tool Options palette and the Brush Variance palette.
- 4 Paint on the image.

A ruby-colored overlay displays the brush strokes. The selection changes according to the following:

- Painting with white adds to the selection.
- Painting with black subtracts from the selection.
- Painting with shades of gray adds to or subtracts from the selection, depending on the level of gray.

- 5 Choose **Selections ▶ Edit Selection**.



The selection marquee surrounds the selected area.



You can also click the **Edit Selection** button  on the Layers palette instead of choosing **Selections ▶ Edit Selection**.

## To create a selection by using the Text tool

Edit workspace

- 1 On the Tools toolbar, choose the **Text** tool .
- 2 On the Tool Options palette, choose **Selection** from the **Create as** drop-list to create a selection shaped like the text.
- 3 Click where you want to start the text selection.
- 4 Set the text formatting controls, and type the text.
- 5 Click the **Apply changes** button .

## To create a raster selection from a vector object

Edit workspace

- 1 On the Tools toolbar, choose the **Pick tool** , and select one or more vector objects.
- 2 Choose **Selections ▶ From Vector Object**.  
A selection marquee surrounds each vector object.



After you create a raster selection from a vector object, you can copy and paste the selection as needed. The original vector objects remain unchanged.

## To select all pixels in a layer or an image

Edit workspace

- Choose **Selections ▶ Select All**.  
A selection marquee appears around the layer on the canvas.



You can also select all pixels in a layer or an image by pressing **Ctrl + A**.

## To select all non-masked areas

Edit workspace

- 1 On the Layers palette, select the mask layer.
- 2 Choose **Selections ▶ From Mask**.  
The selection marquee surrounds the non-masked areas.



If you saved a mask to an alpha channel, you can load it as a selection by choosing **Selections ▶ Load/Save Selection ▶ Load Selection From Alpha Channel**.

## Hiding and displaying the selection marquee

The selection marquee is visible by default. When you work with a selection, it is sometimes helpful to hide the selection marquee temporarily without disabling the selection. For example, you may want to see the results of pasting a selection or of feathering a selection's edges.

### To hide or display the selection marquee

Edit workspace

- Choose **Selections ▶ Hide Marquee**.



When you hide the selection marquee, it does not deselect or clear the selection. The tools and commands you use while the selection marquee is hidden apply only to the selected area.



You can also hide or display the selection marquee by pressing **Ctrl + Shift + M**.

## Moving, clipping, and rotating selections

You can move, clip, or rotate a selection. If you want to change the selection area, you can also move the selection marquee.

When you move a selection, you can leave the space empty or you can move a copy of the selection and leave the original unchanged. When you move a selection, it becomes a floating selection. When you perform a new action, Corel PaintShop Pro automatically promotes the floating selection to a new layer.

You can also float a selection, which creates a copy of the selection that you can move or modify without changing the original image. A floating selection temporarily rests above the image or layer on the

Layers palette, and an icon indicates that the layer contains a floating selection. After you edit the floating selection, you can defloat it.

You can also move a selection to a separate layer. When you do this, the original selection contents are unchanged, and a copy of the selection becomes the new layer. You can edit this new layer without changing the original image.

***Important!** This command works on 16 million–color and grayscale images only. For more information about increasing the color depth of an image, see “Working with colors and materials” on page 385.*

After making a selection, you can move the selection anywhere on the image, or off the canvas. If you expand the image window to show the off-canvas gray area, you can see the selection you moved. You can also clip a selection to remove the portion that is not within the image borders.

## To move the selection marquee

Edit workspace

- Using the Selection tool, right-click and drag the selection marquee to a new position.



You can also move the selection marquee by right-clicking and dragging with the Move tool .

## To move a selected image area

Edit workspace

- Perform a task from the following table.

To	Do the following
Move the selection any distance	In the Tool Options palette set <b>Mode</b> to <b>Replace</b> , and then drag the selection with one of the selection tools (Selection, Freehand, or Magic Wand tool).
Move the selection 1 pixel	Press an arrow key.
Move the selection 10 pixels	Hold down <b>Ctrl</b> , and press an arrow key.
Move the selection 50 pixels	Hold down <b>Shift</b> , and press an arrow key.
Move the selection 100 pixels	Hold down <b>Shift</b> and <b>Ctrl</b> , and press an arrow key.

## To copy and move a selected image area

Edit workspace

- With the **Selection** tool active, set the Mode control to **Replace**, hold down **Alt**, and drag the selection.

### You can also

Copy and move the selection 1 pixel	Hold down <b>Alt</b> , and press an arrow key.
Copy and move the selection 10 pixels	Hold down <b>Alt</b> and <b>Ctrl</b> , and press an arrow key.
Copy and move the selection 50 pixels	Hold down <b>Alt</b> and <b>Shift</b> , and press an arrow key.
Copy and move the selection 100 pixels	Hold down <b>Alt</b> , <b>Shift</b> , and <b>Ctrl</b> , and press an arrow key.

## To float a selection

Edit workspace

- Choose **Selections** ▶ **Float**.

## To defloat a selection

Edit workspace

- Choose **Selections ▶ Defloat**.

## To promote a selection to a layer

Edit workspace

- 1 Create a selection in the image.
- 2 Choose **Selections ▶ Promote Selection to Layer**.

The new Promoted Selection appears above the original layer.



To place a selection as a layer within another image, copy the selection, open the other image, and choose **Edit ▶ Paste As New Layer**.

## To clip a selection to the canvas

Edit workspace

- 1 Move part of the selection off the image canvas.

If necessary, expand the image window to reveal the gray area that appears outside the image borders.

- 2 Choose **Selections ▶ Defloat**.

The selection is defloated, which makes more edit options available.

- 3 Choose **Selections ▶ Clip to Canvas**.

The selection area outside the image borders is removed.

## To rotate a selection

Edit workspace

- 1 Choose **Image ▶ Free Rotate**.

The Free Rotate dialog box appears.

- 2 In the **Direction** group box, choose either **Right** or **Left** to specify the rotation direction.

- 3 In the **Degrees** group box, set the number of degrees to rotate.  
If you want to type a value between 0.01 and 359.99, mark the **Free** option.
- 4 Unmark the **All layers** check box.
- 5 Click **OK**.



When you rotate a selection, the selection becomes a floating selection, and the original image remains unchanged.



You can also rotate a selection interactively by using the **Pick** tool . Before the rotation is applied, the selection is promoted to a layer.

## Modifying selections

Selections can be modified in various ways. You can modify a selection by adding image content to it or by subtracting image content from it. For example, in a picture of a person carrying a large sign, you can select the sign by using the rectangular Selection tool and then add the person to the selection by using the Freehand Selection tool.



*After you create a selection, you can add to it.*

You can also expand or contract a selection by a specific number of pixels.

You can add or remove a color from a selection, or from the selection border. When the color is added or removed, the selection border changes.





You can also add pixels to a selection based on color values.

If specks or holes appear in a selection, you can remove them by defining an area in square pixels. For example, if your image is 20 pixels wide by 20 pixels high, you can define an area of 5 pixels multiplied by a scale factor of 100 to cover an area of 500 pixels. Because the image covers an area of only 400 pixels ( $20 \times 20 = 400$ ), all specks and holes will be removed.

You can also modify a selection by using tools and effects.

## To add to or subtract from a selection

Edit workspace

- 1 On the Tools toolbar, choose a selection tool (**Selection** , **Freehand Selection** , **Magic Wand** , tool, or **Smart Selection Brush** )
- 2 Choose settings for the tool on the Tool Options palette.
- 3 Perform a task from the following table.

To	Do the following
Add to a selection	From the <b>Mode</b> drop-list, choose <b>Add</b> , and select the image areas that you want to add to the selection. The areas do not need to be adjacent.
Subtract from a selection	From the <b>Mode</b> drop-list, choose <b>Remove</b> , and select the image areas that you want to remove from the selection.





You can also add to a selection by holding down **Shift** while clicking the image areas that you want to add, or subtract from a selection by holding down **Ctrl** while clicking the image areas that you want to remove.

## To expand a selection by a specific number of pixels

Edit workspace

- 1 Choose **Selections ▶ Modify ▶ Expand**.

The Expand Selection dialog box appears.

- 2 Specify a value in the **Number of pixels** control by which to expand the selection.
- 3 Click **OK**.

The selection marquee expands while retaining its original shape.

## To contract a selection by a specific number of pixels

Edit workspace

- 1 Choose **Selections ▶ Modify ▶ Contract**.

The Contract Selection dialog box appears.

- 2 Specify a value in the **Number of pixels** control by which to contract the selection.
- 3 Click **OK**.

The selection marquee contracts while retaining its original shape.

## To add pixels to a selection according to color values

Edit workspace

- 1 Choose **Selections ▶ Modify ▶ Select Similar**.

- 2 Check the settings of the following controls on the Tool Options palette, and modify them if necessary:

- **Tolerance** — specifies how closely pixels must match the colors of the initial selection. At lower settings, the values are closer,

and more pixels are excluded from the selection. At higher settings, the values do not need to be as close, and more pixels are included in the selection.

- **Sample Merged** — selects matching pixels in the merged image. If the check box is unmarked, only pixels in the active layer are selected.
- **Anti-alias** — produces a smooth-edged selection by partially filling in pixels along the edge, making them semitransparent. Mark the **Inside** or **Outside** options, depending on whether you want the areas inside or outside the selection marquee to be anti-aliased. To retain the original edges, unmark the **Anti-alias** check box.
- **Contiguous** — selects all pixels of a similar color in adjacent areas
- **Discontiguous** — selects all pixels of a similar color anywhere within the image

### 3 Click **OK**.

The selection changes to include similar pixels.



The Select Similar command produces the best results when the selection is not anti-aliased.

## To add or remove a color from a selection

Edit workspace

- 1 Choose **Selections** ▶ **Modify** ▶ **Select Color Range**.
- 2 Choose one of the following options:
  - **Add color range**
  - **Subtract color range**
- 3 Click a color in the image that you want to add or remove from the selection.

- 4 In the **Tolerance** box, specify a color tolerance value (0 to 256).  
Shades of the color or related colors are added or removed from the selection.
- 5 In the **Softness** box, specify the amount of softness for the referenced color.
- 6 Click **OK**.  
The selection borders change to add or exclude the color you specified.



You can click the **Toggle Selection** button  in the Select Color Range dialog box to toggle between a preview of only the selection and a preview of the selection with the rest of the image.

You can also choose a color to add or remove by clicking in the **Reference color** box in the Select Color Range dialog box.

To remove a color from a selection, you can also choose **Edit ▶ Paste As Transparent Selection** as you paste a selection. This command removes only the color you specify as the background color.

## To remove holes and specks from a selection

*Edit workspace*

- 1 Choose **Selections ▶ Modify ▶ Remove Specks and Holes**.  
The Remove Specks and Holes dialog box appears.
- 2 Choose one of the following options:
  - **Remove Specks**
  - **Remove Holes**
  - **Remove Specks and Holes**

- 3 In the **Square area smaller than** boxes, enter the number of pixels and the scale factor. Start at low values, and increase them as necessary until the specks and holes are removed.
- 4 Click **OK**.  
The holes and specks in the selection are removed.



You can click the **Toggle Selection** button  in the Remove Specks and Holes dialog box to toggle between a preview of only the selection and a preview of the selection with the rest of the image.

## To modify a selection by using tools and effects

Edit workspace

- 1 Choose **Selections ▶ Edit Selection**.  
A ruby overlay appears in the selected area.
- 2 Apply a tool or effect to the selection area.
- 3 When you are finished editing the selection, choose **Selections ▶ Edit Selection** to display the selection marquee.



You can also modify a selection by clicking the **Edit Selection** button .

## Inverting and clearing selections

Sometimes, the easiest way to make a complicated selection is to select the part of the image that you don't want and then invert the selection. For example, in a picture of a person against a solid-color background, you can select the background and then invert the selection, so that the person is selected instead of the background.



*By selecting a solid background (left) and inverting the selection, you can isolate a complex, multicolored foreground (right).*

You can also clear a selection, which removes the selection marquee and integrates the selection back into the image. After clearing the selection, you can resume your editing of the entire image.

### To invert a selection

Edit workspace

- Choose **Selections ▶ Invert**.

The selection marquee now encloses the previously unselected image area and excludes the previously selected image area.

### To clear a selection

Edit workspace

- Choose **Selections ▶ Select None**.



If you deselect a floating selection, the selection is defloated and placed in the underlying layer if the layer is a raster layer. If the underlying layer is a vector layer or an Art Media layer, a new raster layer is created, and the selection is defloated to it.



You can also clear a selection by right-clicking in the image outside the selection marquee or by pressing **Ctrl + D**.

## Using feathering with selections

Feathering softens the area between a selection and the rest of the image by gradually increasing the transparency of the pixels along the edge of the selection. You can specify the width of the feathered area.

When you copy or move a selection, feathering helps blend the selection into the surrounding area so that the image appears more natural. The higher the feathering value is, the softer the edges are. A feathering value of 0 creates a selection with distinct edges.



*An unfeathered selection (left) and a feathered selection (right)*

You can apply feathering as you make a selection, or you can apply it after the selection is created. The level of feathering and its position around the selection marquee can be adjusted after the selection is created. For more information about creating selections, see “Creating selections” on page 292.

## To change the amount of feathering in a selection

Edit workspace

- 1 Choose **Selections ▶ Modify ▶ Feather**.
- 2 Type a pixel value in the **Feather amount** control.  
The feathering is applied both inside and outside the selection.
- 3 Click **OK**.

## To adjust the position of feathering

Edit workspace

- 1 Choose **Selections ▶ Modify ▶ Inside/Outside Feather**.
- 2 Mark one of the following options to set the position of the feathering:
  - **Inside**
  - **Outside**
  - **Both**
- 3 Type a value in the **Feather amount** control to set the feathering width (in pixels).
- 4 Click **OK**.



You can click the **Toggle Selection** button  in the Inside/Outside Feather dialog box to toggle between a preview of only the selection and a preview of the selection and the rest of the image.

## To unfeather a selection

Edit workspace

- 1 Choose **Selections** ▶ **Modify** ▶ **Unfeather**.
- 2 Type a value in the **Threshold** control to specify the amount of feathering you want to remove.
- 3 Click **OK**.

## Using anti-aliasing with selections

Anti-aliasing produces a smooth-edged selection by partially filling in pixels along the edge, making them semitransparent. You can apply anti-aliasing to selections as you create them. For more information about creating selections, see “Creating selections” on page 292.

After a selection is created, you can apply anti-aliasing based on the selection’s shape. You can also restore the original anti-aliasing of an object that was pasted into an image. Restoring anti-aliasing is useful if you made the selection without anti-aliasing and you want to smooth the edges of the selection.

## To apply anti-aliasing based on shape

Edit workspace

- 1 Choose **Selections** ▶ **Modify** ▶ **Shape Based Anti-alias**.  
The Shape Based Anti-alias dialog box appears.
- 2 Mark one of the following options:
  - **Inside** — applies anti-aliasing to the inside of the selection marquee
  - **Outside** — applies anti-aliasing to outside of the selection marquee
- 3 Click **OK**.

The selection edges are anti-aliased.



## To recover anti-aliasing

Edit workspace

- 1 Choose **Selections ▶ Modify ▶ Recover Anti-alias**.

The Recover Anti-alias dialog box appears, with the anti-aliased selection displayed in the After preview area.

- 2 Mark one of the following options:
  - **Inside** — applies anti-aliasing inside the selection marquee
  - **Outside** — applies anti-aliasing outside the selection marquee
- 3 Click **OK**.



To apply anti-aliasing to all layers in the selection, mark the **Use all layers** check box.

To apply anti-aliasing and copy the result to a new layer, mark the **Result on new layer** check box.

## Modifying the edges of selections

You can modify the edges of a selection by smoothing its boundary or by adding a border.

### To smooth the boundary of a selection

Edit workspace

- 1 Choose **Selections ▶ Modify ▶ Smooth**.

The Smooth Selection dialog box appears.

- 2 Mark or unmark the following options:
  - **Anti-alias** — smooths the edges of the selection
  - **Preserve Corners** — preserves the shape of the corners. Unmark this check box if you want to smooth the corners.
- 3 Specify values for one or both of the following controls:

- **Smoothing amount** — specifies the amount of smoothing to apply around the selection
- **Corner scale** — specifies the amount of smoothing to apply around the corners of the selection. This control is not available when the **Preserve Corners** check box is not marked.

4 Click **OK**.



You can click the **Toggle Selection** button  in the Smooth Selection dialog box to toggle between a preview of the selection and a preview of the selection and the rest of the image.

## To add a border to a selection

Edit workspace

1 Choose **Selections ▶ Modify ▶ Select Selection Borders**.

The Select Selection Borders dialog box appears.

2 Mark one of the following options to set the position of the feathering:

- **Inside**
- **Outside**
- **Both**

3 Type a value in the **Border width** box.

If you want to smooth the edges of the selection border, mark the **Anti-alias** check box.

4 Click **OK**.

## Creating custom patterns from selections

You can convert a selection into a seamless custom pattern, which you can use for painting, adding text, or creating Web page backgrounds.

### To create a custom pattern

Edit workspace

- 1 Make a selection.
- 2 Choose **Effects ▶ Image Effects ▶ Seamless Tiling**.  
The Seamless Tiling dialog box appears.
- 3 Choose an option from the **Tiling Method** group box.
- 4 Choose an option from the **Direction** group box.  
If you choose **Bidirectional**, you need to choose a setting from the **Corner Style** group box.
- 5 Modify any of the settings in the **Settings** group box.
- 6 Click **OK**.

## Saving and loading selections

You can save complicated selections that you may want to reuse. You can also save selections as files or as alpha channels.

When you save a selection, it is saved as a separate file with a **.PspSelection** filename extension. When you load a selection into an image, Corel PaintShop Pro creates a selection based on luminance, non-black pixels, or opacity.

Alpha channels in images are data storage areas that hold selections and masks. When you save a selection as an alpha channel, the selection is stored as part of the image on which it was originally created, rather than as a separate file. Selections and masks stored in alpha channels have no effect on the look of an image.

When you save the image in a file format other than the PspImage file format, its alpha channels are not saved. Therefore, it is best to keep a master copy of your image in PspImage format.

When you save a selection to an alpha channel within a PspImage image, you can load that selection from the alpha channel into the same image or into any other image.

If you saved selections to alpha channels that you no longer need, you can delete them. Only alpha channels from the current image can be deleted.

## To save a selection to a file

Edit workspace

- 1 Choose **Selections** ▶ **Load/Save Selection** ▶ **Save Selection to Disk** to open the Save Selection to Disk dialog box.

The Selection Files group box displays selection files in ...Documents\Coreel PaintShop Pro\17.0\Selections. To change the default folder, or to add another folder, click the **File Locations** button  in the **Selection Files** drop-list.

- 2 In the **File name** box, type a name for the selection.
- 3 Click **Save**.

## To load a selection file from disk

Edit workspace

- 1 Choose **Selections** ▶ **Load/Save Selections** ▶ **Load Selection From Disk**.

The Load Selection from Disk dialog box appears.

The **Selection** group box shows selection files in all folders. To change the default folder for locating selections, click the **File Locations** button  in the **Selection** drop-list.

- 2 Choose a selection from the **Selection** drop-list.

- 3 In the **Operation** group box, choose one of the following options:
  - **Replace selection**
  - **Add to current selection**
  - **Subtract from current selection**
- 4 In the **Create Selection From** group box, choose one of the following options:
  - **Source luminance**
  - **Any non-zero value**
  - **Source opacity**
- 5 Click **Load**.

## To save a selection to an alpha channel

Edit workspace

- 1 Choose **Selections ▶ Load/Save Selections ▶ Save Selection to Alpha Channel**.

The Save Selection to Alpha Channel dialog box appears.

- 2 Choose an image from the **Add to document** drop-list in the **Alpha Channels** group box.

Any existing alpha channels in the image are shown in the preview box below the drop-list.

- 3 Click **Save**.

The selection is saved to the alpha channel.

## You can also

---

Save a selection to the alpha channel of another image Select the image name in the **Add to document** drop-list, and click **Save**.

**Note:** The second image must be open in Corel PaintShop Pro for it to appear in the **Add to document** drop-list.

---

## You can also

---

Change the default name for the new alpha channel      Type a new name in the **Name** box.

---

Move the selection to the upper-left corner of the image canvas      Mark the **Move to upper left of canvas** check box.

**Note:** This option is useful when a selection does not appear on the canvas because it is larger than the image.

---

## To load a selection from an alpha channel

Edit workspace

- 1 Choose **Selections ▶ Load/Save Selection ▶ Load Selection From Alpha Channel**.

The Load Selection from Alpha Channel dialog box appears.

If you want to show the area around the selection as either transparent or black, click the **Toggle transparency checkerboard** button  in the **Preview** group box.

- 2 From the **Load From Document** drop-list, choose the filename of the image that contains the alpha channel you want to load.

**Note:** The image must be open in Corel PaintShop Pro for it to appear in the **Load From Document** drop-list.

- 3 In the **Operation** group box, choose one of the following options:
  - **Replace selection**
  - **Add to current selection**
  - **Subtract from current selection**

A message in the **Operations** group box indicates how the alpha channel intersects the canvas of the current image.

**Note:** If the alpha channel does not intersect the image canvas or intersects it only partially, you can move the selection onto the image canvas by marking the **Move to upper left** check box.

- 4 In the **Options** group box, choose one or more of the following options:
  - **Move to upper left**
  - **Clip to canvas**
  - **Invert selection**
- 5 Click **Load**.

### You can also

---

Clip the selection wherever it extends beyond the image canvas In the **Options** group box, mark the **Clip to canvas** check box.

---

Select everything outside the original selection In the **Options** group box, mark the **Invert image** check box.

---

## To delete an alpha channel

Edit workspace

- 1 Choose **Image ▶ Delete Alpha Channel**.

The Delete Alpha Channel dialog box appears.

- 2 Choose the alpha channel you want to delete from the drop-list in the **Alpha Channels** group box.

If you want to delete all alpha channels, mark the **Delete all alpha channels** check box.

- 3 Click **Delete**.





When you work with layers in Corel PaintShop Pro, you can add elements to your images, create artistic effects and illustrations, and edit your images more easily. You can add or delete layers, rearrange the order in which they are stacked, and blend their pixels in various ways. Unless you merge the layers, you can edit each one independently of the others.

This section presents the following topics:

- Understanding layers
- Using layers with photos
- Using layers with illustrations
- Using the Layers palette
- Creating layers
- Promoting the background layer
- Deleting layers and clearing layer contents
- Duplicating and copying layers
- Renaming layers
- Viewing layers
- Organizing layers by color
- Changing the order of layers in an image
- Moving layers on the canvas
- Grouping layers

- Linking layers
- Blending layers
- Setting layer opacity
- Protecting transparent areas of raster layers
- Merging layers
- Using adjustment layers
- Using layer styles

## Understanding layers

When you create or import an image in Corel PaintShop Pro, the image has a single layer. Depending on the type of image you create or import, the single layer is labeled as Background, Raster, Vector, or Art Media. When you open a photo, scan, or screen capture, the single layer is labeled as Background on the Layers palette.

For most simple corrections and retouching, you do not have to add layers to an image. However, it is a good practice to duplicate the single layer before making image corrections, so that you preserve the original image on its own layer. If you intend to do more complex work, such as creating a collage with text and other elements or creating a photo composition with layers of effects — the use of layers is highly recommended.



*Layers are like separate sheets that you combine to create a final composition.*

Each layer you add begins as a transparent sheet over the background. As you add brushstrokes, vector objects, or text, you cover up parts of the Background layer. Transparent areas let you see the underlying layers. You can stack multiple layers to create artistic compositions, photo collages, or complex illustrations.

There are nine types of layers: Background, Raster, Vector, Art Media, Mask, Adjustment, Group, Selection, and Floating Selection. For information about the last three types, see “Working with selections” on page 291.

Only grayscale and 16 million–color images can have multiple raster-based layers (Vector layers are the only non raster-based layers). When you add a new raster-based layer to an image of another color depth, such as a 256-color indexed image, Corel PaintShop Pro automatically converts the layered image to 16 million colors.

Corel PaintShop Pro supports up to 500 layers. The actual number of layers allowed in an image may be limited by the available memory in your computer.

You can create layer groups or promote selections to layers. For information about promoting selections to layers, see “Moving, clipping, and rotating selections” on page 303.

## Background layers

The background layer  is the bottom layer of an image. When you import JPEG, GIF, or PNG images into Corel PaintShop Pro, they have only this single layer, which is named “Background” on the Layers palette.

The background layer contains raster data and is promoted to a raster layer when you change its properties, such as its blend mode or opacity. You cannot change its stacking order unless you promote it to a raster layer.

To position a background layer higher in the layer stack, you can promote it to a regular raster layer. For information about promoting the background layer, see “Promoting the background layer” on page 340.

If you create a new image with a transparent background, it does not have a background layer, and its bottom layer is a raster layer named “Raster 1.” You can move this layer anywhere within the stacking order. You can also change its opacity and blend mode.

Corel PaintShop Pro supports transparency on layers other than the background. To create an image without transparent areas, you can choose a solid-colored background. The image contains a background layer as the bottom layer.

To create a new image with transparent areas, choose a transparent background. The image contains a raster layer as the bottom layer. For more information, see “Creating images” on page 69.

## Raster layers

Raster layers  are layers with raster data only. Raster data is composed of individual elements, called pixels, arranged in a grid. Each pixel has a specific location and color. Photographic images are composed of raster data. If you magnify raster data, you can see the individual pixels as squares of colors.

Raster layers let you display subtle changes in tones and colors. Some tools, options, and commands apply only to raster layers. For example, the painting tools and the commands that are used to add effects can be applied only on raster layers. If you try to use a raster tool while a vector layer is selected, Corel PaintShop Pro prompts you to convert the vector layer into a raster layer.

For more information about raster and vector data, see “Understanding raster and vector objects” on page 552.

## Vector layers

Vector layers  are layers with only vector objects (lines and shapes), vector text, or vector groups. Vector objects and text are composed of geometric characteristics — lines, curves, and their locations. When you edit vector objects and text, you edit these lines and curves, rather than the individual pixels. Vector graphics and vector text maintain their clarity and detail at any size or print resolution.

Objects or text created with vector layers can be easily edited. Images of any color depth can include multiple vector layers. Each vector layer contains a list of all individual vector objects on that layer. You can expand or collapse the group to view the individual objects. For more information, see “To expand or collapse a vector layer or layer group” on page 337. Vector objects can be moved from their layer group to another vector group.

You cannot move a vector object to a nonvector layer; vector objects must be placed on vector layers. If you create a vector object while a raster layer is selected, Corel PaintShop Pro creates a vector layer just above the selected layer.

For more information about raster and vector data, see “Understanding raster and vector objects” on page 552.

## Art Media layers

Art Media layers  are automatically created when you use any of the Art Media tools.

When creating a new image, you can choose to create the image with an Art Media layer.

Art Media layers can be converted to raster layers, but not to vector layers.

## Mask layers

Mask layers  show or hide portions of underlying layers. A mask is an adjustment layer that modifies opacity. You can use masks to create sophisticated effects, such as a picture frame that fades away at the center to reveal the subject.

Mask layers cannot be bottom layers. You cannot delete other layers if deleting them would cause a mask layer to become the bottom layer.

For more information about working with masks, see “Working with masks” on page 369.

## Adjustment layers

Adjustment layers are correction layers that adjust the color or tone of underlying layers. Each adjustment layer makes the same correction as



an equivalent command on the Adjust menu, but unlike the command, the adjustment layer does not change image pixels.

Adjustment layers cannot be the bottom layer. You cannot delete other layers if deleting them would cause an adjustment layer to become the bottom layer. For more information, see “Using adjustment layers” on page 359.

## Using layers with photos

When you open a digital photo or a scanned image, the image appears on the background layer. For most photographic enhancements, such as cropping, correcting colors, or retouching, you do not need to add additional layers. By adding layers as you work, however, you can create interesting effects and make corrections more easily. The following table provides examples.

To	Do the following
Preserve the original image before making changes	Make a duplicate of the background layer by choosing <b>Layers ▶ Duplicate</b> . To work on the duplicate layer, make it the active layer by clicking it on the Layers palette.
Make color and tonal corrections	Use adjustment layers instead of changing the image directly. For more information about using adjustment layers, see “Using adjustment layers” on page 359.
Add text or graphics	Create text and graphics, such as lines and shapes, on vector layers to make them easier to edit. For more information about adding text, see “Working with text” on page 531. For more information about vector graphics, see “Drawing and editing vector objects” on page 551.

To	Do the following
Create effects	Duplicate the background layer, apply an effect to the duplicate, and then blend the two layers by changing the opacity or blend modes of the layers.
Create a painting	Choose an Art Media tool from the Tools toolbar and mark the <b>Trace</b> check box on the Tool Options palette (an Art Media layer is created automatically). Use the Art Media brushes to create impressionistic effects.
Combine photos to create a photo collage	<p>Open the photos that you want to combine and decide which image to use as your base image. Copy the other images into the base image by clicking an image, choosing <b>Edit ▶ Copy</b>, clicking the base image, and choosing <b>Edit ▶ Paste As New Layer</b>. Position each layer with the <b>Move</b> tool .</p> <p>Use the opacity setting and blend mode to control how much of each layer shows through. Use a mask layer to hide parts of a layer or to create soft edges around it.</p>
Create a panoramic photo	<p>Take a series of photos with overlapping subject matter.</p> <p>Create an image with a canvas large enough to display a panorama, and then copy each photo onto a separate layer. Decrease the opacity of one layer so that you can see through it, and use the <b>Move</b> tool  to match up the edges of the next layer. After all layers have been positioned, return their settings to 100 percent opacity.</p>



## Using layers with illustrations

Using layers is invaluable when you work with illustrations. The following table provides examples.

<b>To</b>	<b>Do the following</b>
Make changes easier	Create individual components on separate layers to make them easier to edit. For example, for an illustration of a car speeding down a highway in the mountains, create the car, the driver, the highway, and the mountains on separate layers. For more information, see “Creating layers” on page 338.
Move multiple layers together on the image canvas	Link or group layers that need to move together. For example, link the car and the driver in the previous example so that when you move the car, the driver moves with it. For more information, see “Linking layers” on page 349.
Edit graphical elements	Create vector objects on vector layers for objects that you need to fine-tune or edit. For more information, see “Creating layers” on page 338.

Apply raster-only commands and effects to vector objects

Create a new layer with raster copies of the vector objects. To do this, duplicate the vector layer, and then convert it to a raster layer. Turn off the visibility of the vector layer to work on the raster layer.

For more information about duplicating layers, see “Duplicating and copying layers” on page 342. For more information about hiding layers, see “To show or hide all layers” on page 344.

---

Experiment with changes

Make a copy of a layer, and make changes to it. Copy other layers, and make changes to them. Turn the visibility of layers off and on to find which layer works best for the overall image.

---

Save work in progress

Keep a copy of the intermediate steps of transformations, and then turn off the visibility of those layers. Keeping a copy lets you retrace your steps later if you need to.

---

## Using the Layers palette

The Layers palette lists all layers in an image. The order of layers on the palette is the order of layers in the image. The top layer is listed first, and the bottom layer is listed last. You can change the stacking order of layers on the Layers palette, depending on the layer types.

For information about layer types, see “Understanding layers” on page 326.

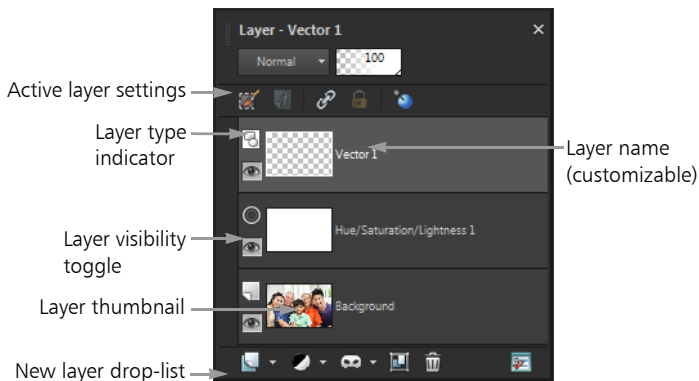

*The Layers palette*

You can create layer groups to organize the Layers palette. You can also link layers or groups so that they move together when you use the Move tool in the image.

By default, a thumbnail view of the layer's contents appears to the left of the layer name. You can set the size of the thumbnail or turn the thumbnail off. By default, the settings of the active layer appear above the topmost thumbnail preview, but you can modify the appearance of these settings. For more information about changing the appearance of the Layers palette, see "To modify the look of the Layers palette" on page 337.

The Layers palette displays the names of layers and layer groups. You can customize the names of layers in the palette (see examples in the illustration above). It also indicates the types of layers (background, raster, vector, art media, mask, adjustment, group, selection, or floating selection) and lets you toggle the layer visibility on or off. If there are too many layers for the palette to display at one time, you can use the scroll bars on the right side to move the list up or down.

The Layers palette toolbar, positioned along the bottom edge of the palette, includes controls for tasks such as adding new layers, grouping and deleting layers, and provides a quick access button for setting preferences.

At the top of the Layers palette are controls that let you change the blend mode and opacity of layers, enable Edit Selection, display Layer Effects, link layers, lock transparency, and access layer styles.

You can display or hide the Layers palette or move it anywhere on the screen. For more information about moving, docking, and undocking the Layers palette, see “Using palettes” on page 30.

If an image has more than one layer, you must select the layer that you want to work on. Changes to the image affect only the selected layer (also called the active layer). You can select only one layer at a time.

The Layers palette displays its components as a “tree” of folders and subfolders. Items with subcomponents have a down-facing arrow in front of them when expanded, and a right-facing arrow in front of them when contracted. You can expand a vector layer or layer group to see the names of its subcomponents, or contract a vector layer or layer group to navigate the Layers palette more easily.

## To display or hide the Layers palette

Edit workspace

- Choose **View ▶ Palettes ▶ Layers**.

This command toggles the display of the Layers palette on and off.

## To select a layer



Edit workspace

- On the Layers palette, click the name of a layer.

## To expand or collapse a vector layer or layer group

Edit workspace

- Perform a task from the following table.

To	Do the following
Expand the group	On the Layers palette, click the right-facing arrow  in front of the layer or layer group name.
Collapse the group	On the Layers palette, click the down-facing arrow  in front of the layer or layer group name.

## To modify the look of the Layers palette

Edit workspace

- 1 Choose **File** ▶ **Preferences** ▶ **General Program Preferences**.  
The General Program Preferences dialog box appears.
- 2 On the left pane of the dialog box, choose **Palettes**.
- 3 Perform a task from the following table, and click **OK**.

To	Do the following
Resize thumbnails	In the <b>Layers palette</b> group box, mark the <b>Palette thumbnails</b> check box, and type or set a value in the <b>Size</b> control. (The default setting is 50 pixels.)
Turn off thumbnails and display the right pane	In the <b>Layers palette</b> group box, unmark the <b>Palette thumbnails</b> check box, and mark the <b>Right Pane</b> check box. (This is how the Layers palette appeared in earlier versions of the application.)

To	Do the following
Resize the right pane	With the right pane of the Layers palette displayed, drag the pane flyout control horizontally.
Display layer settings at the top of the palette	In the <b>Layers palette</b> group box, unmark the <b>Right Pane</b> check box.



You can hide the right pane by clicking when the arrow on the vertical divider points to the right. When the arrow points to the left, clicking the control restores the right pane to its previous view.

## Creating layers

You can create a layer from the Layers palette. When you create a layer, you can specify properties such as the layer type, opacity, or blend mode. These properties can be modified as you work with the layer. You can create layers from selections, vector objects, or other images.

Layers are created automatically when you use the Text tool, Art Media tools, or vector drawing tools, such the Pen tool or the Preset Shape tool.

### To create a layer from the Layers palette

*Edit workspace*

- 1 On the Layers palette, click the layer above which you want create a layer.
- 2 From the drop-list on the toolbar of the Layers palette, choose a layer type:
  - **New Raster Layer**
  - **New Vector Layer**

- New Art Media Layer
  - New Layer Group
  - New Mask Layer
  - New Adjustment Layer
- 3 Adjust the available controls for the layer properties.
  - 4 Click **OK**.

The new layer is added above the active layer. It is named with the layer type and a number, such as “Vector 1.”



For more information about renaming layers, see “Renaming layers” on page 343.

Only grayscale and 16 million–color images can have multiple raster-based layers (Vector layers are the only non raster-based layers). When you add a new raster-based layer to an image of another color depth, such as a 256-color indexed image, Corel PaintShop Pro automatically converts it to 16 million colors.



You can create a layer quickly by holding down **Shift**, and choosing an option from the New Layer drop-list.

## To create a raster layer from a selection

Edit workspace

- Choose **Selections ▶ Promote Selection to Layer**.

The new layer is named “Promoted Selection.”



When you promote a selection, some pixels surrounding the selection border may be included, especially if the selection is anti-aliased or feathered. For information about cleaning up a selection before you copy or promote it, see “Modifying selections” on page 307.



You can also create a raster layer by choosing **Edit ▶ Copy** and then choosing **Edit ▶ Paste As New Layer**. The name of the new layer contains “Raster” plus a number, for example, “Raster 1.”

## To create a vector layer from vector objects

Edit workspace

- 1 On the Tools toolbar, choose the **Pick** tool , and select one or more vector objects.
- 2 Choose **Edit ▶ Copy**.
- 3 Choose **Edit ▶ Paste As New Layer**.

## To create a layer from another image

Edit workspace

- 1 In the image window, click the image you want to copy for the new layer, and choose **Edit ▶ Copy**.
- 2 Click the image on which you want to paste the new layer, and choose **Edit ▶ Paste As New Layer**.

The layer is pasted on the center of the canvas in the second image.



You can also drag a layer from the Layers palette and drop it onto an image.

## Promoting the background layer

To have the Background layer to function like other layers, you can promote it to a regular raster layer. Raster layers support transparency and can be moved anywhere within the stacking order. For more information about the background layer, see “Understanding layers” on page 326.



## To promote the background layer to a regular raster layer

Edit workspace

- Choose **Layers ▶ Promote Background Layer**.



You can also right-click on the layer and choose **Promote Background Layer**.

## Deleting layers and clearing layer contents

You can remove a layer from an image or clear the contents of a layer. Clearing a layer's contents keeps the layer within the image; raster and vector layers become transparent, and the background layer is filled with the current background color and material.

### To delete a layer

Edit workspace

- 1 On the Layers palette, select the layer or layer group you want to delete.
- 2 Click the **Delete Layer** button .

### You can also

---

Delete a selected layer from the Layers menu

Choose **Layers ▶ Delete**.

---

Delete a selected layer by right-clicking

Right-click on the Layers palette, and choose **Delete**.

---

Delete a selected layer by dragging

Drag the layer to the **Delete Layer** button.

---

### To clear the contents of a layer

Edit workspace

- 1 On the Layers palette, click the name of the layer you want to clear.

Make sure that nothing is selected outside the layer.

- 2 Choose **Edit ▶ Clear**.



You can also clear a layer by pressing **Delete**.

## Duplicating and copying layers

You can duplicate a layer within an image. You can use the duplicated layer as a starting point for a new layer, or you can try out edits and effects on the duplicated layer while keeping the original layer intact. You can also copy a layer to another image by copying and pasting or by dragging the layer into another image.

### To duplicate a layer within an image

Edit workspace

- Select the layer you want to duplicate, and choose **Layers ▶ Duplicate**.

The duplicated layer is added just above the selected layer.



You can also right-click the layer name and choose **Duplicate**.

You can also choose **Edit ▶ Copy** to copy the layer and then choose **Edit ▶ Paste As New Layer**.

### To copy a layer to another image

Edit workspace

- 1 On the Layers palette, select the layer you want to copy.
- 2 Choose **Edit ▶ Copy**.
- 3 Open the image in which you want to paste the layer.

If the image has layers, click a layer. When the copied layer is pasted, it will appear above the selected layer.

- 4 Choose **Edit ▶ Paste As New Layer**.

The layer is pasted on the center of the canvas.

## To copy a layer and drag it into another image

- 1 In the **Edit** workspace, open both images.
- 2 In the **Layers** palette, drag the layer that you want to copy from one image to the tab of the other image, and when the other image becomes active, drop the layer in the position you want in the **Layers** palette.



The **Edit** workspace must be in **Tabbed Documents** mode (**Window > Tabbed Documents**) to drag and drop layers between images.

## Renaming layers

As you add layers to an image, you may find it convenient to rename them so that they are easy to identify on the Layers palette.

### To rename a layer

Edit workspace

- 1 On the Layers palette, click the layer you want to rename, pause a moment, and click again.

The name appears highlighted in a box.

- 2 Type the new name in the box, and press **Enter**.



You can also rename a layer by double-clicking the layer to display the Layer Properties dialog box and typing a new name in the **Name** box.

## Viewing layers

You can make layers, layer groups, or vector objects visible or invisible in the image. The invisible layers remain in the image but are hidden from view. You can also invert visible and hidden layers.

### To display or hide a layer

Edit workspace

- Click the **Visibility Toggle** button for the layer that you want to display or hide.



— **Visibility Toggle** button when the layer is displayed



— **Visibility Toggle** button when the layer is hidden



Hiding a layer group hides all layers within that group.



To show the selected layer only, choose **Layers ▶ View ▶ Current Only**.

### To show or hide all layers

Edit workspace

- Perform a task from the following table.

To	Do the following
View all layers	Choose <b>Layers ▶ View ▶ All</b> .
Hide all layers	Choose <b>Layers ▶ View ▶ None</b> .

### To invert visible and hidden layers

Edit workspace

- Choose **Layers ▶ View ▶ Invert**.

All previously visible items are hidden, and all hidden items become visible.

## Organizing layers by color

To organize the Layers palette visually, you can specify highlight colors for layers and layer groups. The highlight color appears as the background of the icon to the left of the layer or group name. It has no effect on the image itself.

In a layer group, layers that have not been assigned individual highlight colors inherit the color of the parent layer. You can use the same highlight color for all layers in a layer group and different colors for layers in other layer groups.

### To set a highlight color for a layer icon

*Edit workspace*

- 1 On the Layers palette, double-click the layer to open the Layer Properties dialog box.
- 2 Mark the **Highlight in Layers Palette** check box.
- 3 Click the color box next to the check box.
- 4 Choose a color, and click **OK**.
- 5 In the Layer Properties dialog box, click **OK**.  
The icon appears with the highlight color.



To choose a highlight color for recently used colors, right-click the color box, and click a color.

## Changing the order of layers in an image

The order of layers within an image is critical to the appearance of the image. To rearrange layers in the image, you can easily change the stacking order of layers in the Layers palette. If a layer or a layer group has components, such as vector objects or grouped layers, all of the

components move with the layer or layer group when its position in the stacking order is changed.

## To move a layer or layer group

Edit workspace

- On the Layers palette, select the layer or layer group, and drag it to a new position in the stack.

A gray line shows the layer's position as you drag.



When you drag a layer, the cursor changes to a hand. A cursor displaying a null symbol  indicates that the selected item cannot be moved to a particular position.



You can also move a layer or layer group by choosing **Layers** ▶ **Arrange** and then choosing an option.

## Moving layers on the canvas

You can move the contents of an entire layer anywhere within the image canvas. If you move part of a layer off the canvas, the layer is not cropped — you can move it back to the canvas or increase the canvas size to display the hidden area. For more information, see “Resizing the canvas” on page 271.

## To move a layer on the canvas

Edit workspace

- 1 On the Layers palette, select the layer that you want to move.
- 2 On the Tools toolbar, click the **Move** tool .
- 3 Drag in the image to move the layer to a new position.



You can also select and move layers with the **Pick** tool .

## Grouping layers

You can create layer groups to group multiple layers together. Layer groups let you

- organize the Layers palette
- set layer properties, such as opacity and blend mode, for the whole group
- limit the effect of adjustment and mask layers to the layers underneath the active layer rather than to the entire image
- move all grouped layers together in the stacking order
- move linked layers together on the image canvas
- delete all layers in the group

Layer groups can contain raster, vector, art media, mask, and adjustment layers and must contain at least one layer. Layer groups can also contain other layer groups, called nested groups. If you move all of the layers out of a layer group, Corel PaintShop Pro deletes the layer group.

For information about viewing layer groups, see “To expand or collapse a vector layer or layer group” on page 337.

### To create a layer group

Edit workspace

- 1 On the Layers palette, select the first layer you want to include in the layer group.
- 2 From the drop-list on the toolbar of the Layers palette, choose **New Layer Group**.

The layer group is created, and the selected layer becomes part of the layer group. By default, the layer group name contains “Group” plus a number (for example, “Group 1”).

## You can also

---

Add a layer to a layer group from the Layers palette	On the Layers palette, drag a layer into the layer group. (A black line shows the layer's position as you drag.)
Add a layer to a layer group from the Layers menu	Choose <b>Layers ▶ Arrange ▶ Move Into Group</b> .
Position a layer group within another layer group	On the Layers palette, drag a layer group into another layer group. (A black line shows the layer group's position as you drag.)
Move a layer to the bottom of a layer group	Drag the layer to the second-to-bottom position, and then drag the bottom layer up one level. <b>Note:</b> Dragging a layer directly to the bottom of a layer group positions it below the group rather than within it.
Create a layer group from the Layers menu	Choose <b>Layers ▶ New Layer Group</b> , set the necessary controls in the Layer Properties dialog box, and click <b>OK</b> .

---

## To remove a layer from a group

Edit workspace

- Drag the layer to a new position outside the layer group.



You can also remove a layer from a group by choosing **Layers ▶ Arrange ▶ Move Out of Group**.

## To ungroup layers

Edit workspace

- Select the layer group that you want to ungroup, and choose



## Layers ▶ Ungroup Layers.

### Linking layers

You can link layers to have them move together on the image canvas when you move one layer with the Move tool.

You can link grouped layers, which allows all layers within a layer group to move together on the image canvas. You can also link individual layers from different layer groups and move them together without moving other layers in the layer group.

#### Does linking affect the stacking order?

Linking does not affect the stacking order; it affects only the movements you make with the Move tool on the image canvas. The only way to move layers together in the stacking order is to group them. When you move a layer group in the stacking order, all layers move, regardless of whether the group is linked or unlinked.

#### To link layers

Edit workspace

- 1 On the Layers palette, select the layers that you want to link, and click the **Link/Unlink** button .

#### To unlink layers

Edit workspace

- On the Layers palette, select the layer you want to unlink, and click the **Link/Unlink** button .

The link icon is removed from the layer.

#### To link or unlink a layer group

Edit workspace

- On the Layers palette, select the layer group you want to link or

unlink, and click the **Link/Unlink group** button .

The button appears highlighted on the toolbar when a linked group is selected; the button is not highlighted when you select an unlinked group.



You can also link or unlink a group by double-clicking the layer group to display the Layer Properties dialog box, marking or unmarking the **Group is linked** check box, and clicking **OK**.

## Blending layers

You can create interesting effects by changing the way the pixels on one layer blend with pixels on underlying layers. Corel PaintShop Pro offers a variety of blend modes. By default, the image displays the blended pixels while the individual layers remain unchanged.

When layers are blended, each layer has a blend mode of Normal, which blends pixels based on the opacity of the selected layer. The selected layer is blended with all underlying layers, not just the layer directly beneath it.

You can set the blend range of a layer in addition to its blend mode. By default, the blend mode applies to all pixels. The blend range limits the pixels that the blend mode affects. Blend ranges set the opacity based on brightness or color channel, so that colors drop out of the selected layer and other colors show through.

### Understanding blend modes

The table below describes each of the blend modes.

Blend mode	Result
------------	--------

Normal	Displays pixels of underlying layers based on the opacity of pixels on the selected layer. If the selected layer is fully opaque, no pixels show through. As the opacity decreases, more pixels from underlying layers show through.
Darken	Displays pixels in the selected layer that are darker than the underlying layers. Pixels lighter than the underlying layers disappear.
Lighten	Displays pixels in the selected layer that are lighter than the underlying layers. Pixels darker than the underlying layers disappear.
Hue	Applies the hue of the selected layer to the underlying layers (without changing the saturation or lightness).
Hue (Legacy)	Functions similarly to the Hue blend mode. This blend mode is retained for the sake of compatibility with earlier versions of the program.
Saturation	Applies the saturation of the selected layer to the underlying layers, without affecting the hue or lightness. This blend mode is available for 16 million-color images only.
Saturation (Legacy)	Functions similarly to the Saturation blend mode. This blend mode is retained for the sake of compatibility with earlier versions of the program.

Color	Applies the hue and saturation of the selected layer to the underlying layers (without affecting the lightness). This blend mode is available for 16 million–color images only.
Color (Legacy)	Functions similarly to the Color blend mode. This blend mode is retained for the sake of compatibility with earlier versions of the application.
Luminance	Applies the luminance (or lightness) of the selected layer to the underlying layers, without affecting the hue or saturation. This blend mode is available for 16 million–color images only.
Luminance (Legacy)	Functions similarly to the Luminance blend mode. This blend mode is retained for the sake of compatibility with earlier versions of the program.
Multiply	Combines the colors of the selected layer with the underlying layers to produce a darker color. Multiplying any color with black produces black; multiplying any color with white leaves the color unchanged. This blend mode produces the same result regardless of the order in which the layers are stacked on the Layers palette.

Screen	Lightens the colors of underlying layers by multiplying the inverse of the selected layer and of the underlying layers. The result is a color that is the same or a lightened version of the selected layer. This blend mode produces the same result regardless of the order in which the layers are stacked on the Layers palette.
Dissolve	Randomly replaces the colors of some pixels on the selected layer with those of the underlying layers to create a speckled effect. The opacity of the selected layer determines the number of pixels replaced: the lower the opacity, the greater the number of pixels replaced.
Overlay	Combines the Multiply and Screen blend modes. If the color channel value of underlying layers is less than half the maximum value, the Multiply blend mode is used. If the color channel value is greater than or equal to half the value, the Screen blend mode is used. The Overlay blend mode shows patterns or colors of the selected layer while preserving the shadows and highlights of underlying layers.

Hard Light	Combines the Multiply and Screen blend modes. If the color channel value of the selected layer is less than 128, the Multiply blend mode is used. If the color channel value is greater than or equal to 128, the Screen blend mode is used. You can use the Hard Light blend mode to add highlights or shadows.
Soft Light	Combines the Burn and Dodge blend modes. If the color channel value of the selected layer is less than 128, the Burn blend mode is used. If the color channel value is greater than or equal to 128, the Dodge blend mode is used. You can use the Soft Light blend mode to add soft highlights or shadows.
Difference	Subtracts the color of the selected layer from the color of the underlying layers. This blend mode produces the same result regardless of the order in which the layers are stacked on the Layers palette.
Dodge	Lightens the image by using the lightness values of the colors in the selected layer to lighten the colors of underlying layers. Light colors produce the most lightening; black has no effect.
Burn	Darkens the image by using the lightness values of the selected layer to reduce the lightness of underlying layers.

Exclusion

Creates an effect similar to, but softer than, the Difference blend mode. The Exclusion blend mode produces the same result regardless of the order in which the layers are stacked on the Layers palette.

---

## To set the blend range of a layer

Edit workspace

- 1 On the Layers palette, double-click the layer to open the Layer Properties dialog box.
- 2 Click the **Blend Ranges** tab.
- 3 In the Blend Channel drop-list, select a channel to use when blending layers.

Select **Grey Channel** to base opacity on the lightness values of layers. Select **Red Channel**, **Green Channel**, or **Blue Channel** to base opacity on the respective color values.

- 4 Drag the upper arrows to set the values at which the opacity is 100 percent.

For example, you can set a layer's opacity at 100 percent between the lightness values of 43 and 126, with the opacity falling off at the lightest and darkest areas.

- 5 Drag the lower arrows to set the values at which the opacity is 0 percent.
- 6 Click **OK**.

## Setting layer opacity

To create interesting effects, you can vary the opacity of a layer from the default of 100 percent (fully opaque) down to 0 percent (fully transparent). When a layer is partially transparent, the underlying layers show through.

You can also change the opacity of a layer group.

The Opacity setting on the Layers palette determines the opacity of each layer. The overall opacity of a layer and the opacity of individual pixels are independent of each other. For example, if a pixel starts at 50 percent opacity and the layer is set to 50 percent opacity, the pixel appears as 25 percent opaque. If the layer is in a layer group that is set to 50 percent opacity, then the pixel appears as 12.5 percent opaque.

## To set the opacity of a layer

Edit workspace

- 1 On the Layers palette, select the layer or layer group.
- 2 Drag the **Opacity** slider  to the desired percentage.



You can also set layer opacity by double-clicking the layer, changing the **Opacity** setting in the Layer Properties dialog box, and clicking **OK**.

## Protecting transparent areas of raster layers

To apply tools and effects only to certain areas of a raster layer with data, you can use the Lock Transparency feature. Transparent areas remain protected when you paint, apply effects, paste selections, or make other modifications.

***Important!** The Lock Transparency feature applies to raster layers only. You cannot lock the transparency of vector, art media, adjustment, mask, or group layers. Background layers do not support transparency.*

## To lock or unlock transparent areas of a raster layer

Edit workspace

- On the Layers palette, select the layer, and click the **Lock/Unlock**



button .

The **Lock/Unlock** button appears on the layer when transparency is locked. Click the button again to unlock the transparency. The icon on the layer disappears when the layer is unlocked.



You can also lock or unlock transparent areas by double-clicking the layer, marking or unmarking the **Lock transparency** check box in the Layer Properties dialog box, and clicking **OK**.

## Merging layers

Merging layers in an image is also referred to as “flattening” an image. You can choose to merge all layers or only selected layers in an image. Merging layers decreases the memory requirements for the image. Layers are merged according to blend modes, vector data and vector text are converted to raster data, and transparent areas of the background layer are replaced with white.

Many file formats, such as JPEG, GIF, and TIF, do not support multilayer images. When you save images to these formats, Corel PaintShop Pro merges all layers into a single background layer. When you save to the PSD (Photoshop) format, the image maintains raster and adjustment layers, but vector layers and art media layers are converted to raster layers.

The following table describes how layer types are merged.

Top layer	Merged with	Results in
Any layer	Raster layer	Raster layer
Vector layer	Vector layer	Vector layer
Art Media layer	Background	Background
Mask layer	Mask layer	Mask layer
Any layer	Background	Background

***Important!** You should always make a backup copy of the original Ps/Image image before you merge layers. After you merge layers, you cannot edit the layers separately.*

## To merge two layers together

Edit workspace



- 1 Make sure that one layer is located directly above the other on the Layers palette.
- 2 Select the top layer.
- 3 Choose **Layers ▶ Merge ▶ Merge Down**.



To merge all layers, choose **Layers ▶ Merge ▶ Merge All (Flatten)**.

## To merge all visible layers

Edit workspace

- 1 On the Layers palette, click the **Visibility Toggle** button  for each layer that you do not want to merge.  
When the layer is hidden, the **Visibility Toggle** button changes to .
- 2 Choose **Layers ▶ Merge ▶ Merge Visible** to merge all visible layers into one raster layer.



Invisible layers are not affected. The merged layer, which maintains the transparency information of the original layers, appears at the position of the active layer.

If the selected layer is in a group, only the visible layers in that group are merged. If the layer group is marked as invisible (making all layers within the group invisible), then none of the layers within the group are merged.

## To merge all layers in a group

Edit workspace

- 1 On the Layers palette, select the layer group, or the layer within the group, that you want to merge.
- 2 Choose **Layers ▶ Merge ▶ Merge Group** to merge all layers in the group into one raster layer.

## Using adjustment layers

Adjustment layers are correction layers that adjust the color or tone of underlying layers without modifying the image layers themselves. You can add adjustment layers to test various color corrections or combinations of corrections. You can hide, delete, or edit adjustment layers.

An adjustment layer affects all layers below it. If an adjustment layer is in a layer group, it affects only the layers that are below it in the group. To apply an adjustment layer to a single layer without affecting the underlying layers, you can create a layer group with one layer and then add the adjustment layer above the layer in the group. Only the layer in the layer group is affected.

## To add an adjustment layer

Edit workspace

- 1 On the Layers palette, click a layer.

When the adjustment layer is added, it will appear above the selected layer.

- 2 From the drop-list on the palette toolbar, choose **New Adjustment Layer**, and select an adjustment layer type.

In the dialog box that appears, the preview areas show the image before and after you make changes.

To reset the values to default settings, choose **Default** from the **Load Preset** drop-list.

- 3 Click the **Adjustment** tab, and set the controls for the adjustment layer.
- 4 Click **OK**.



You can also add an adjustment layer by choosing **Layers ▶ New Adjustment Layer**.

You can also reset the values to the default by double-clicking the adjustment layer and clicking the **Reset to Default** button  in the Properties dialog box.

## To hide or view the adjustment layer overlay

Edit workspace

- Choose **Layers ▶ View Overlay**.



You can also hide or display the adjustment layer overlay by clicking the **Mask Overlay Toggle** button  on the Layers palette.

## To edit an adjustment layer

Edit workspace

- 1 On the Layers palette, double-click the name of the adjustment layer that you want to edit.

The Layer Properties dialog box appears.

- 2 Click the **Adjustment** tab, and modify the color or tonal correction settings.
- 3 Click the **General** tab to modify the general layer properties such as layer name, blend mode, and opacity.
- 4 On the **Overlay** tab, adjust the color and opacity of the overlay. The default overlay is a reddish, mask-like layer with 50 percent opacity.
- 5 Click **OK**.



You can also open the Layer properties dialog box by choosing **Layers ▶ Properties**.

## Using layer styles

You can apply a variety of effects, either alone or in combination, by using the **Layer Styles** tabbed area of the Layer Properties dialog box. With this feature, you can create visually interesting and creative effects to a layer in real time, and you can fine-tune the effect before applying it. The Layer Styles feature provides six effects: Reflection, Outer Glow, Bevel, Emboss, Inner Glow, and Drop Shadow.

When you apply these effects on a separate layer and save the resulting file in a layer-capable file format (such as the PsdImage format), your original image remains unedited on its own layer. In this sense, layer styles are similar to adjustment layers. They differ, however, in that layer styles are applied not to the underlying canvas, but just to the boundaries of the individual layer.

If you resize a layer with one or more layer styles applied to it, the effects are resized proportionally.

Layer styles can be applied only to raster and vector layers.

Some layer styles (such as Drop Shadow) are applied outside the layer's data. Some layer styles won't be seen unless the layer includes areas of transparency.

### **Why is there a "Layer" check box?**

When marked, this check box lets you show the layer data with the effects applied. When unmarked, this check box lets you turn off the layer data and just show the effects. Unmarking the **Layer** check box makes the original layer data behave as if a mask were applied to it.

### **Is there a reason for the check box order?**

Yes. The effects need to be composited in a particular order to obtain sensible results. For example, you would not want a Drop Shadow effect placed on top of its source object, nor would you want an Outer Glow effect placed under a Drop Shadow effect. Thus, the Reflection effect is placed on top, followed by the Outer Glow effect, the Bevel effect, and so on. The Drop Shadow effect is applied last.

### **What happens when I edit layers with effects?**

Whether you edit a vector layer by adding new text or shapes, or edit a raster layer by painting with a brush tool, the effects previously applied to the layer are applied to any modifications you make.



*Layers Styles examples*

## To apply a Reflection layer style

Edit workspace

- 1 Click a layer, and click the **Layer Styles** button .
- 2 In the Layer Properties dialog box, click the **Layer Styles** tab.
- 3 In the group box that lists the effects, mark the **Reflection** check box.

The After pane is updated to show the initial Reflection effect. If you want to preview the changes on the actual image, mark the **Preview on Image** check box.

**Note:** The Reflection effect may create data that extends beyond the viewable image canvas, so you may need to expand the canvas to see the entire effect.

- 4 Drag the **Size** slider to set the speed with which the reflection fades in comparison with the original layer data.
- 5 Drag the **Opacity** slider to set the intensity of the reflection's overall lightness.
- 6 Drag the red Reflection Distance control line to set the horizontal axis about which all layer data is reflected.
- 7 Click **OK**.



You can save Layer Styles settings as a preset and then apply them at any time to another layer. For more information on saving and applying presets, see “Using and creating presets” on page 721.

## To apply an Outer Glow layer style

Edit workspace

- 1 Click a layer, and click the **Layer Styles** button .
- 2 In the Layer Properties dialog box, click the **Layer Styles** tab.
- 3 In the group box that lists the effects, mark the **Outer Glow** check box.

The After pane is updated to show the initial Outer Glow effect. If you want to preview the changes on the actual image, mark the **Preview on Image** check box.

**Note:** The Outer Glow effect may create data that extends beyond the viewable image canvas, so you may need to expand the canvas to see the entire effect.

- 4 Drag the **Size** slider to set how far the glow extends outside the layer data.
- 5 Drag the **Opacity** slider to set the lightness intensity and visibility of the glow.
- 6 In the rainbow color picker, click a glow color. The current color appears along the bottom row of the color picker.
- 7 Click **OK**.





You can save Layer Styles settings as a preset and then apply them at any time to another layer. For more information on saving and applying presets, see “Using and creating presets” on page 721.



## To apply a Bevel layer style

Edit workspace

- 1 Click a layer, and click the **Layer Styles** button .
- 2 In the Layer Properties dialog box, click the **Layer Styles** tab.
- 3 In the group box that lists the effects, mark the **Bevel** check box.  
The After pane is updated to show the initial Bevel effect. If you want to preview the changes on the actual image, mark the **Preview on Image** check box.
- 4 Drag the **Size** slider to set the distance from the outer edge of the layer data to the extent of the bevel.
- 5 Drag the **Opacity** slider to set lightness intensity and visibility of the bevel.
- 6 Drag the two-dimensional lighting control  to set the direction and distance of the light applied to the effect.
- 7 In the rainbow color picker, click a bevel color. The current color appears along the bottom row of the color picker.
- 8 Click **OK**.



You can save Layer Styles settings as a preset and then apply them at any time to another layer. For more information on saving and applying presets, see “Using and creating presets” on page 721.

## To apply an Emboss layer style

Edit workspace

- 1 Click a layer, and click the **Layer Styles** button .
- 2 In the Layer Properties dialog box, click the **Layer Styles** tab.
- 3 In the group box that lists the effects, mark the **Emboss** check box.

The After pane is updated to show the initial Emboss effect. If you want to preview the changes on the actual image, mark the **Preview on Image** check box.

- 4 Drag the **Size** slider to set the distance from the outer edge of the layer data to the extent of the embossing.
- 5 Drag the **Opacity** slider to set lightness intensity and visibility of the embossing.
- 6 Drag the two-dimensional lighting control  to set the direction and distance of the light applied to the effect.
- 7 Click **OK**.



You can save Layer Styles settings as a preset and then apply them at any time to another layer. For more information on saving and applying presets, see “Using and creating presets” on page 721.

## To apply an Inner Glow layer style

Edit workspace

- 1 Click a layer, and click the **Layer Styles** button .
- 2 In the Layer Properties dialog box, click the **Layer Styles** tab.
- 3 In the group box that lists the effects, mark the **Inner Glow** check box.

The After pane is updated to show the initial Inner Glow effect. If you want to preview the changes on the actual image, mark the **Preview on Image** check box.

- 4 Drag the **Size** slider to set how far glow extends inside the layer data.
- 5 Drag the **Opacity** slider to set the lightness intensity and visibility of the glow.

- 6 In the rainbow color picker, click a glow color. The current color appears along the bottom row of the color picker.
- 7 Click **OK**.



You can save Layer Styles settings as a preset and then apply them at any time to another layer. For more information on saving and applying presets, see “Using and creating presets” on page 721.

## To apply a Drop Shadow layer style

Edit workspace

- 1 Click a layer, and click the **Layer Styles** button .
- 2 In the Layer Properties dialog box, click the **Layer Styles** tab.
- 3 In the group box that lists the effects, mark the **Drop Shadow** check box.

The After pane is updated to show the initial Drop Shadow effect. If you want to preview the changes on the actual image, mark the **Preview on Image** check box.

**Note:** The Drop Shadow effect may create data that extends beyond the viewable image canvas (particularly on a layer the same size as the Background layer), so you may need to expand the canvas to see the entire effect.

- 4 Drag the **Size** slider to set the distance between the layer data and the shadow.  
As you increase the size, the shadow becomes more blurred.
- 5 Drag the **Opacity** slider to set lightness intensity and visibility of the shadow.
- 6 Drag the two-dimensional lighting control  to set the direction and distance of the light applied to the effect.
- 7 In the rainbow color picker, click a shadow color. The current color appears along the bottom row of the color picker.

- 8 Click **OK**.



You can save Layer Styles settings as a preset and then apply them at any time to another layer. For more information on saving and applying presets, see “Using and creating presets” on page 721.

## To adjust the layer data visibility

Edit workspace

- 1 Click a layer that has effects applied, and click the **Layer Styles** button .

**Note:** When you modify the visibility of layer data, you are not changing the visibility of the effects applied to the layer.

- 2 In the Layer Properties dialog box, click the **Layer Styles** tab.
- 3 In the group box that lists the effects, mark the **Layer** check box.

The After pane is updated to show the effect of marking the box. If you want to preview the changes on the actual image, mark the **Preview on Image** check box.

Drag the **Opacity** slider to set the light intensity and visibility of the layer data.

- 4 To turn off layer data visibility, unmark the **Layers** check box.
- 5 Click **OK**.

## To display or hide layer effects

Edit workspace

- 1 On the Layers palette, click a layer that has effects applied.
- 2 Click the **Layer Effects Visibility Toggle** button  to display or hide the effects.

A layer effect icon  displays on the layer when the effect is visible. The icon disappears when the effect is hidden.



In Corel PaintShop Pro, you can use masks to hide or show parts of a layer, fade between layers, and create other special effects.

This section presents the following topics:

- Understanding masks
- Displaying masks
- Creating masks
- Deleting masks
- Editing masks
- Loading masks
- Saving masks

## Understanding masks

Masks are grayscale raster layers that cover parts of the layers in your image, either completely or with varying levels of opacity. You can use masks to fade between layers, or to create special effects with precision. For example, you can mask the details around the main subject in a photo, or you can use a mask to create a fading navigation bar for a Web page.

Mask pixels display 256 shades of gray, with each shade corresponding to levels of opacity. White pixels show underlying layers, black pixels hide underlying layers, and gray pixels show varying amounts of underlying layers.

Mask layers cannot be the bottom layer in the image or in a layer group. If the mask layer is at the main level (rather than in a layer group), the mask applies to all layers below it in the stacking order. If a mask layer is in a layer group, it applies only to layers within the group that are lower in the stacking order.

## Displaying masks

A mask overlay is displayed over protected areas to make it easy to differentiate between masked and unmasked areas. The mask overlay is a red-tinted, transparent sheet. If you adjust the transparency of a mask in certain areas, the degree of red displayed by the mask overlay in those areas varies accordingly.

When you paint or modify the mask, the mask overlay shows what is painted or changed.

You can hide or show a mask layer while you edit an image.

### To display or hide the mask overlay

Edit workspace

- On the Layers palette, click the **Highlight mask area** button  in the upper right corner of the palette.

The button appears highlighted when the overlay is displayed.



You can also display or hide the mask overlay by choosing **Layers ▶ View Overlay**.

### To change the mask overlay color and opacity



Edit workspace

- 1 On the Layers palette, right-click the mask layer and choose **Properties**.
- 2 Click the **Overlay** tab.

- 3 Click the **Overlay color** area, and choose a color.
- 4 Drag the **Opacity** slider to set the level of opacity.
- 5 Click **OK**.

## To display or hide a mask

Edit workspace

- Click the **Visibility Toggle** button on the Layers palette.
  -  — **Visibility Toggle** button when the mask is displayed
  -  — **Visibility Toggle** button when the mask is hidden

## Creating masks

You can create a mask from an image by loading the image file from disk. When you use an image as a mask for another image, Corel PaintShop Pro applies the mask as a grayscale image. The source image is not altered. You can also create a mask by customizing one of the sample masks included with Corel PaintShop Pro.



*An example of an image used as a mask*

You can use a selection to create a mask that shows or hides the selection. You can use this mask as a starting point for creating artistic effects.



*An example of a selection used as a mask*

You can also create a mask from a channel by first splitting an image into its RGB, HSL, or CMYK channels. Corel PaintShop Pro creates a grayscale image for each channel. You can use one of these channel images to create a mask for the original image or for another image.



*An example of the grayscale channel used as a mask*

## To create a mask layer

Edit workspace

- 1 On the Layers palette, choose the layer that you want to mask.
- 2 Choose **Layers ▶ New Mask Layer**, and choose one of the following options:
  - **Show All** — shows all underlying pixels
  - **Hide All** — hides all underlying pixels

## You can also

---

Display the mask on the image

On the Layers palette, click the **Highlight mask area** button .

---



## You can also

---

View the image as it will appear in print or online (without the transparency grid or the mask overlay) Choose **View ▶ Palettes ▶ Overview**.

---

Reorder the layers on which the mask is applied Drag the mask layer on the Layers palette to a new position in the stacking order.

To apply the mask layer to all underlying layers, drag it from the layer group to the main level.



You can paint on the image to show portions of the underlying layer. For information about editing the mask, see “Editing masks” on page 377.

For information about stacking layers, see “Changing the order of layers in an image” on page 345.

## To create a mask from an image

Edit workspace

- 1 Open the image that you want to use as a mask.
- 2 On the Layers palette, choose the layer that you want to mask.
- 3 Choose **Layers ▶ New Mask Layer ▶ From Image** to open the Add Mask From Image dialog box.
- 4 Open the **Source Window** drop-list, and choose the image.
- 5 In the **Create Mask From** group box, choose one of the following options:
  - **Source luminance** — determines the degree of masking based on the luminance value of the pixel color. Lighter colors produce less masking; darker colors produce more masking. Transparent areas completely mask the layer.

- **Any non-zero value** — applies masking without gradation. Pixels with an opacity between 1 and 255 pixels become white; transparent pixels become black. Transparent areas completely mask the layer.
- **Source opacity** — determines the degree of masking based on the opacity of the image. Fully opaque pixels produce no masking; partially transparent pixels create more masking; transparent pixels produce full masking.

If you want to reverse the transparency of the mask, mark the **Invert mask data** check box.

6 Click **OK**.



The mask layer and the selected layer are added to a new layer group. The mask layer applies to the selected layer only.

For information about editing a mask, see “Editing masks” on page 377.





To display the mask on the image, click the **Highlight mask area** button  on the Layers palette.

To apply the mask layer to all underlying layers, drag it from the layer group to the main level on the Layers palette.

## To create a mask from a selection

Edit workspace

- 1 Make a selection on a layer by using the **Selection** tool , the **Freehand Selection** tool , or the **Magic Wand** tool .
- 2 Do one of the following:
  - To mask the selection, choose **Layers ▶ New Mask Layer ▶ Hide Selection**.
  - To mask everything except the selection, choose **Layers ▶ New Mask Layer ▶ Show Selection**.

## You can also

---

Display the mask on the image	On the Layers palette, click the <b>Highlight mask area</b> button  .
Apply the mask layer to all underlying layers	On the Layers palette, drag the mask layer from the layer group to the main level.

---



If you apply a mask layer to the background, the background is automatically converted to a raster layer.

The mask layer and the selected layer are added to a new layer group. The mask layer applies to the selected layer only.

For information about editing masks, see “Editing masks” on page 377.

## To create a mask from a channel

Edit workspace

- 1 Choose **Image ▶ Split Channel**, and choose one of the following:
  - **Split to RGB**
  - **Split to HSL**
  - **Split to CMYK**
- 2 Select the grayscale image in which you want to create the mask.
- 3 Choose **Layers ▶ New Mask Layer ▶ From Image** to open the Add Mask From Image dialog box.
- 4 In the **Source Window** drop-list, choose the channel that you want to use for the mask.
- 5 In the **Create Mask From** group box, choose the **Source luminance** option.

If you want to reverse the transparency of the mask data, mark the **Invert mask data** check box.

## 6 Click **OK**.

The mask layer and the selected layer are added to a new layer group. The mask layer applies to the selected layer only.

### You can also

---

Display the mask on the image

On the Layers palette, click the **Highlight mask area** button .

---

Apply the mask layer to all underlying layers

On the Layers palette, drag the mask layer from the layer group to the main level.

---



For information about editing the mask, see “Editing masks” on page 377.

For information about color channels, see “Working with colors and materials” on page 385.

## Deleting masks

You can delete a mask from an image, or you can merge it with the underlying layer and then delete the mask layer. However, if you merge the mask with the underlying layer, you can no longer edit the mask independently from the layer.

### To delete a mask

Edit workspace

- 1 On the Layers palette, right-click the mask layer, and choose **Delete**.

A message appears asking if you want to merge the mask with the underlying layer.

- 2 Choose one of the following:
  - **Yes** — merges the layers and deletes the mask layer
  - **No** — deletes the mask layer without affecting the underlying layer



You can also delete a mask by choosing **Layers ▶ Delete**.

## Editing masks

When you edit a mask, you change either its area or the degree of masking. For example, painting over an object to mask it changes the area, whereas applying a gradient fill changes the degree of masking.

You can invert the transparency of a mask, so that black pixels become white, white pixels become black, and shades of gray become their mirror value, which is the maximum value (255) minus the current value.

You can use a gradient, pattern, or texture mask to create interesting effects. A gradient mask varies the opacity of an image from fully hidden to fully transparent by fading the image in or out. A pattern or texture mask varies the image opacity in a repeated pattern throughout the image.



*Using a gradient mask*



*Using a pattern mask*

You can edit the layer properties of a mask, such as the name, visibility, or opacity. For more information, see “Working with layers” on page 325.



## To invert a mask

Edit workspace

- 1 On the Layers palette, click a mask layer.
- 2 Choose **Layers ▶ Invert Mask/Adjustment**.

## To create a gradient, pattern, or texture mask

Edit workspace

- 1 Create a new mask.
- 2 Click the **Highlight mask area** button  on the Layers palette to display the mask overlay.
- 3 On the Tools toolbar, click the **Flood Fill** tool .  
If you want to fill all pixels in the mask, set the **Match mode** control on the Tool Options palette to **None**.
- 4 On the Materials palette, choose a gradient, texture, or pattern.
- 5 Click the mask to apply the foreground material; right-click the mask to apply the background material.



For information about creating masks, see “Creating masks” on page 371.

For information about gradients, patterns, or textures, see “Using gradients” on page 395, “Using patterns” on page 404, or “Using textures” on page 407.

## Loading masks

When you save a mask to an alpha channel within an image that is saved in PspImage format, you can load that mask from the alpha channel into the same image or into any other image.

The Masks folder of the Corel PaintShop Pro program folder contains sample masks that you can load into images, such as gradients and several types of circles and squares that frame images. Mask files have a **.PspMask** filename extension.

### To load a mask from an alpha channel

Edit workspace

- 1 On the Layers palette, choose the layer that you want to mask.
- 2 Choose **Layers ▶ Load/Save Mask ▶ Load Mask From Alpha Channel** to open the Load Mask from Alpha Channel dialog box.
- 3 In the **Load from Document** drop-list, choose the image that contains the alpha channel that you want to load. Choose only open images with existing alpha channels.
- 4 In the drop-list under the document name, choose the alpha channel that contains the mask.
- 5 In the **Orientation** group box, choose one of the following options:
  - **Fit to canvas**
  - **Fit to layer**
  - **As is**
- 6 In the **Options** group box, choose one of the following options:
  - **Hide all mask** — hides pixels surrounding a loaded mask that is smaller than the current image canvas
  - **Show all mask** — shows pixels surrounding a loaded mask that is smaller than the current image canvas



If you want to invert the transparency of the mask image, mark the **Invert transparency** check box.

#### 7 Click **Load**.

The mask layer and the selected layer are added to a new layer group.



The mask layer applies to the selected layer only. To apply the mask layer to all underlying layers, drag it from the layer group to the main level.

## To load a mask from disk

### Edit workspace

- 1 On the Layers palette, click the layer that you want to mask.
- 2 Choose **Layers ▶ Load/Save Masks ▶ Load Mask From Disk** to open the Load Mask From Disk dialog box.
- 3 In the **Mask** group box, click the drop-list to choose from mask and image files.

The Preview group box displays the selected mask on the image canvas.

- 4 In the **Orientation** group box, choose one of the following options:
  - **Fit to canvas** — adjusts the mask to fit the current image canvas (stretching or contracting as needed)
  - **Fit to layer** — adjusts the mask to fit the current layer data (stretching or contracting as needed). If the layer has not been shifted beyond the edges of the canvas, this option produces the same results as the Fit to Canvas option.
  - **As is** — positions the mask in the upper-left corner of the current layer. This option does not change the mask proportions. If the mask image is smaller than the current layer,

Corel PaintShop Pro masks all pixels outside of the mask image boundaries.

- 5 In the **Options** group box, choose an option to specify whether any pixels Corel PaintShop Pro surrounding the loaded mask data are shown or hidden. These options affect the mask only if the Orientation option is As Is and the loaded mask is smaller than the current image canvas.
  - **Invert transparency** — inverts the transparency of the mask image
  - **Hide all mask** — makes surrounding pixels black to hide underlying pixels
  - **Show all mask** — makes surrounding pixels white to show underlying pixels
  - **Use image value** — makes surrounding pixels white or black, depending on whether the Show All Mask option or the Hide All Mask option was applied to the original mask.
- 6 Click **Load**.



Corel PaintShop Pro adds the mask layer and the selected layer to a new layer group. The mask layer applies to the selected layer only. To apply the mask layer to all underlying layers, drag it from the layer group to the main level.

## Saving masks

Corel PaintShop Pro saves masks as separate files in PspMask format. You can load a mask into another image without opening the original image. After the mask is loaded, it is automatically saved with the image in PsplImage format. If you want to share a mask or use it in another image, you can save the mask to your hard drive or to an alpha channel.

An alpha channel is a data storage area within an image. Masks and selections stored in alpha channels have no effect on the appearance of an image. You can save a mask to an alpha channel within the current image or within another image. For more information on saving or loading selections in alpha channels, see “Saving and loading selections” on page 319.

***Important!** When you save the image to a file format other than PsdImage format, the alpha channels are not saved. To retain the alpha channels, you should always save a master copy of your image in PsdImage format.*

## To save a mask to disk

Edit workspace

- 1 On the Layers palette, click the mask layer.
- 2 Choose **Layers ▶ Load/Save Mask ▶ Save Mask to Disk** to open the Save Mask To Disk dialog box.

The Mask Files group box displays the filenames of the masks in the default Masks folder. The New Mask group box displays the current mask.

- 3 Click **Save**.



By default, mask files are stored in ...Documents\Corel PaintShop Pro\17.0\Masks. For information about setting file locations, see “Setting file locations” on page 691.

## To save a mask to an alpha channel

Edit workspace

- 1 On the Layers palette, click the mask layer.
- 2 Choose **Layers ▶ Load/Save Mask ▶ Save Mask To Alpha Channel** to open the Save Mask to Alpha Channel dialog box.
- 3 In the **Add To Document** drop-list, choose an alpha channel.

If you want to save a mask to an alpha channel in another image, open the other image in Corel PaintShop Pro, and click it to make it active.

If you want to change the name of the alpha channel, type a new name in the **Name** group box.

- 4 Click **Save**.



Whether you are applying color to an image, creating Web projects, or designing scrapbook pages, it's important to understand how to choose and manage colors and materials in Corel PaintShop Pro.

This section presents the following topics:

- Using the Materials palette
- Choosing colors in the Material Properties dialog box
- Choosing colors for paletted images
- Choosing colors from an image or the desktop
- Using gradients
- Editing gradients
- Exporting and importing gradients
- Using patterns
- Using textures
- Working with custom palettes and swatches

## Using the Materials palette

Corel PaintShop Pro lets you paint, draw, and fill with a variety of styles and materials.

- A style is a color, gradient, or pattern.
- A material is the style plus an optional texture.

Both styles and materials can be selected from the Materials palette.

You can display the Materials palette at any time. You can leave it open while you work, or you can display it only when you need it.

You can also reverse the foreground and background colors or materials.

## The Materials palette

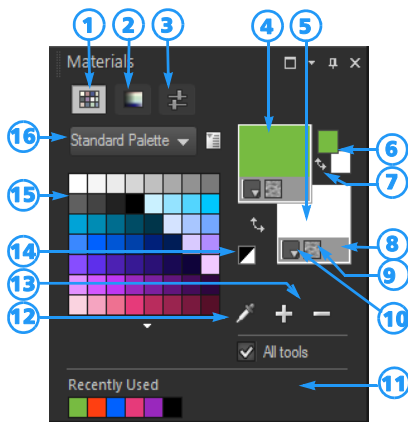





- 1 Swatches tab
- 2 HSL Map tab
- 3 Sliders tab
- 4 Foreground and Stroke Properties
- 5 Background and Fill Properties
- 6 Foreground and Background color boxes
- 7 Swap Colors button
- 8 Transparent option
- 9 Texture button
- 10 Style — Color, Gradient, Pattern
- 11 Recently Used
- 12 Sample Color tool
- 13 Add to Palette and Remove from Palette
- 14 Set to Black and White
- 15 Current palette
- 16 Palette selection menu



## Main components of the Materials palette

- **Swatches** tab — displays swatches for the currently selected palette. Swatches are materials you can save to use again. For more information about swatches, see “Working with custom palettes and swatches” on page 409.
- **HSL Map** tab — displays a Saturation and Lightness box that you can click to adjust the currently selected color or click to adjust a

new color that you select by dragging the slider on the Color (hue) bar.

- **Sliders** tab — displays sliders and value boxes that you can use to set a color in the following color spaces: RGB, HSL, CMYK, Lab, Web safe. You can also set a shade using Grayscale.
- **Foreground and Stroke** and **Background and Fill Properties** boxes — display the current foreground and background materials, which consist of the style (color, gradient, or pattern) and optional texture. You can click either box to display the Material Properties dialog box, in which you can set material options. These boxes can be used in the following ways:
  - You can use foreground materials for brush strokes and background materials for fills.
  - When you apply strokes with a brush (including the fill tools), clicking lets you paint with the foreground material, and right-clicking lets you paint with the background material.
  - When you are using the Art Media tools, you can set the foreground color for the pigment that you apply to the canvas.
  - For text and vector shapes, you can set the foreground color for the stroke (or outline) of the text or shape, and the background color for the fill of the text or shape. For more information about changing the color of text and vector objects, see “To modify vector object properties” on page 563.
- **Foreground** and **Background Color** boxes — display the current foreground and background color and let you set colors regardless of current material
- **Style** button  — shows which style is currently selected: color , gradient , or pattern . To change between the most recently selected color, gradient, and pattern, you can click the Style button and select a new style from the drop-list. Note

that these options are disabled for the Art Media tools, which use only solid colors.

- **Texture** button  — turns the current texture on or off
- **Set to Black and White** button  — sets the foreground to black and the background to white. This is helpful when you use the Edit Selection command.
- **Transparent** button  — specifies whether the foreground or background material is transparent. You use a transparent material primarily with vector objects and text. A transparent foreground has no outline (only the objects or letters are filled), and a transparent background has no fill (only the objects or letters are outlined). This button is unavailable for tools that require a foreground or background material.
- **All tools** check box — specifies whether the selected foreground and background materials apply to all tools. If the check box is unmarked, the selected materials apply only to the active tool.

## Why does the Materials palette have both properties and color boxes?

You can select colors by clicking the Foreground and Background Properties boxes, so you may wonder why the Materials palette also includes color boxes. The color boxes provide a quick way to change colors without changing the other materials. This means that you can select a new color even when the properties box displays a gradient or pattern.

If the properties boxes and the color boxes on the Materials palette are showing different colors, the brush paints with the gradient, texture, or pattern shown in the properties boxes rather than with the color in the color boxes. The colors shown in the color boxes become active when you select Color  from the Style buttons for the Foreground and Background Properties boxes.



## To display or hide the Materials palette

Edit workspace



- Choose **View ▶ Palettes ▶ Materials**.



You can also close the palette by clicking the **Close** button  in the palette's title bar or by pressing **F2**.

## To swap the foreground and background colors or materials

Edit workspace

- From the Materials palette, click the **Swap Colors** button  or click the **Swap Materials** button .

## Choosing colors in the Material Properties dialog box

When you edit images in Corel PaintShop Pro, you often need to choose a color before painting, drawing, or filling, making manual color corrections, or choosing a background for a new raster image. The Color page in the Material Properties dialog box is the most versatile tool for choosing colors, especially if you're building a custom color palette. The color harmonies help you choose colors that look great together.

The Color page appears when you click the Foreground/Stroke Properties box, the Background/Fill Properties box, or one of the two smaller Color boxes. It also appears when you click a Color box found in other dialog boxes.

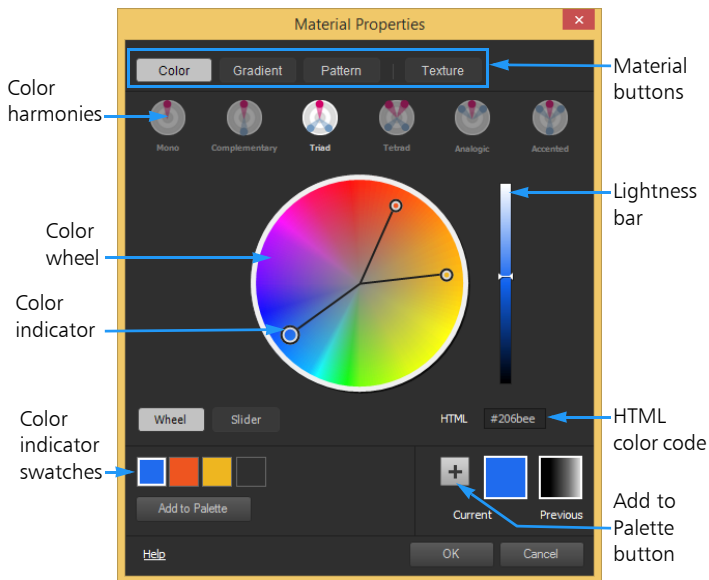

*The Color page in the Material Properties dialog box*

The appearance of the Color page depends on the color depth of the active image (16 bits/channel, 8 bits/channel, 256 colors, 16 colors, or 2 colors). For example, for paletted colors, the Wheel, Slider, and Color Harmonies options are not available—swatches display.

The Color page offers many ways to select colors:

- **Wheel** — clicking the **Wheel** button displays the Color (hue) wheel and the Lightness bar.
- **Slider** — clicking the slider button displays a color space drop list and the corresponding sliders and value boxes. You can select **RGB**, **HSL**, **CMYK**, **Lab**, **Web safe**, **Grayscale**.

- **Color Harmonies** — clicking one of the following color harmony settings helps you choose multiple colors that look good together: **Complementary, Triad, Tetrad, Analogic, Accented**. The **Mono** setting is the default for a single color.



The associated color swatches appear in the lower left corner of the Color page. Click a swatch and click **Add to Palette** to add one or more color swatches to a custom palette.

- **HTML** color code lets you enter HTML color values.

For more information about color and how it is perceived, displayed, and printed, see “Understanding color and color models” on page 647.

## To choose a color in the Material Properties dialog box

Edit workspace

- 1 On the Materials palette, do one of the following:
  - To choose a foreground color, click the **Foreground and Stroke Properties** box or the **Foreground Color** box.
  - To choose a background color, click the **Background and Fill Properties** box or the **Background Color** box.

The Material Properties dialog box appears.

Click the **Color** button to display the **Color** page.

- 2 Do one of the following:
  - Click **Wheel**, and click a color on the color wheel to select the approximate color. Drag the color indicator from the center of the circle to the outer edge to adjust the saturation. Darken or lighten the color by dragging the slider on the Lightness bar that appears to the right of the color wheel.

- Click **Slider**, and choose a color space from the drop-list. Adjust the corresponding sliders or type values in the boxes to set the color you want.
- In the **HTML** box, enter a hex color value.

The current and previous color swatches appear in the lower right corner of the dialog box.

3 Click **OK**.

### You can also

---

Choose more than one color by using color harmonies.

Click one of the following color harmony buttons: **Complementary, Triad, Tetrad, Analogic, Accented**. The associated color swatches appear in the lower left corner of the Color page. Drag the color indicator in the color wheel to adjust the colors. Click a swatch and click **Add to Palette** to add one or more color swatches to a custom palette.

---



You can also choose a color directly on the Materials palette. To use the current colors with all tools, mark the **All tools** check box on the Materials palette. If you unmark this check box, the current materials are used by the active tool only.

## Choosing colors for paletted images

Paletted images are images that have a color depth between 2 and 256 colors. With paletted images, you must choose foreground and background colors from the Materials palette rather than from the Color page.

### To choose colors for paletted images

Edit workspace

- 1 On the Materials palette, do one of the following:
  - To choose the foreground color, click the **Foreground and Stroke Color** box.
  - To choose the background color, click the **Background and Fill Color** box.

Clicking a color box opens the Color page and displays the palette.

- 2 In the **Sort order** drop-list, select the way in which the colors are sorted:
  - **Palette** — sorts by order of colors in the palette
  - **Hue** — sorts by color
  - **Luminance** — sorts by lightness
- 3 Click a color.
- 4 Click **OK**.



To ensure that only the colors available for paletted images are displayed in the Materials palette, the **Show document palette** option must be enabled. Choose **File ▶ Preferences ▶ General Program Preferences**, click **Palettes** in the list, and choose the **Show Document Palette** option. For more information, see “Setting Display and Caching preferences” on page 670.

## Choosing colors from an image or the desktop

You can choose a foreground or background color from any open image, or from any color within Corel PaintShop Pro (such as a color on a toolbar). This feature is useful when you want to use the color of a specific icon, or when you want to match the Windows desktop colors. You can also choose a color from other applications or from Web pages displayed in a browser.

### To choose a color from the active image with the Dropper tool

Edit workspace

- 1 On the Tools toolbar, choose the **Dropper** tool .
- 2 On the Tool Options palette, set the options you want:
  - **Sample Size** drop-list — specifies the pixel area for sampling
  - **Use all layers** check box — mark this check box to sample from all image layers
- 3 Click a color in the image to make it the foreground color, or right-click to make it the background color.



You can also choose a color from the image while using brush tools, such as the Paint Brush or the Eraser tool, by holding down **Ctrl** and clicking in the image to choose a foreground color or right-clicking to choose a background color.

### To choose a color from the desktop

Edit workspace

- 1 Make sure that the color you want is displayed on the screen.
- 2 In the Materials dialog box, click the **Sample Color** button .
- 3 Position your pointer over the area of the desktop that has the color you want. This includes other open windows or displayed Web pages.

4 Click to select the color.

The selected color appears in the active color or properties box.



When positioned over areas that can be sampled, the Sample Color dropper icon displays.

## Using gradients

Gradients are gradual blends between two or more colors. You can paint, draw, or fill with gradients to create interesting effects or color transitions. You can use gradients to create Web buttons with shadows and highlights, to make objects look shiny or glowing, or to add dimension to objects. You can also use gradients to fade Web page graphics into other content, and you can use a black-to-white gradient as a mask.

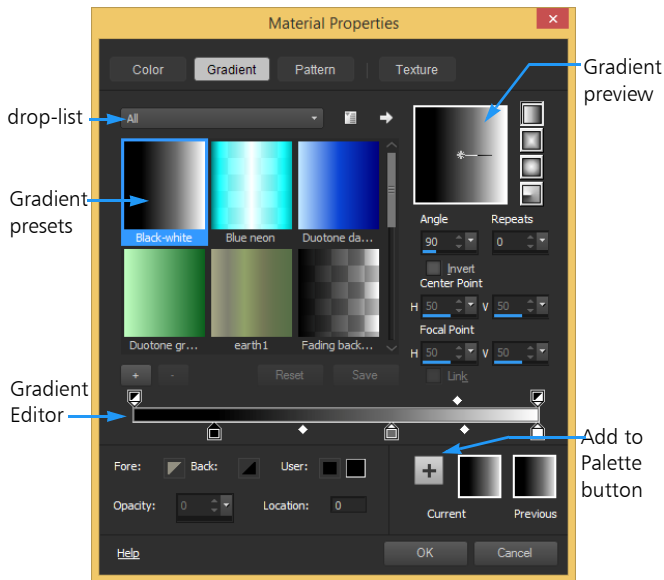

*The Gradient page in the Material Properties dialog box lets you choose and edit gradients.*

For information about editing, creating, and sharing gradients, see “Editing gradients” on page 400 and “Exporting and importing gradients” on page 403.

**Important!** Gradients are available for grayscale and 16 million color-images only. For more information about increasing the color depth of an image, see “Increasing the color depth of an image” on page 632.

## To apply the current gradient

Edit workspace

- On the Materials palette, click the **Gradient** button  on the **Style** drop-list for the Foreground and Stroke Properties box or the



Background and Fill Properties box.





The most recently chosen gradient becomes active.

## To choose a gradient

Edit workspace

- 1 On the Materials palette, do one of the following:
  - To choose a foreground gradient, click the **Foreground and Stroke Properties** box.
  - To choose a background gradient, click the **Background and Fill Properties** box.

The Material Properties dialog box appears.

- 2 Click the **Gradient** button.
- 3 If necessary, choose a gradient category from the **Category** drop-list containing the desired gradients.
- 4 Click a gradient thumbnail.
- 5 Choose one or more of the following options:
  - **Style** — lets you choose a **Linear** , **Rectangular** , **Sunburst** , or **Radial**  gradient.
  - **Angle** — specifies the angle or direction of the gradient, from 0 to 359 degrees. This option applies to linear, rectangular, and radial gradients only.
  - **Repeats** — sets the number of times (from 0 to 999) to repeat the gradient pattern
  - **Invert** — inverts the colors of the gradient
  - **Center Point** — determines the horizontal and vertical coordinates of the point from which the gradient disperses or radiates. The distance is measured as a percentage of the fill area's width. You can change the center point to create fills in circles or other shapes in which the center of the gradient is not

at the center of the object. This option applies to rectangular, sunburst, and radial gradients only.

- **Focal Point** — determines the horizontal and vertical coordinates of the point where the foreground color of the gradient begins. The distance is measured as a percentage of the fill area's width. You can change the focal point to create fills in circles or other shapes in which the effective light source is not at the center of the object. This option applies to rectangular and sunburst gradients only, and is available only when the **Link** check box is unmarked.
- **Link center and focal points** — assigns the same values to the center and focal points. Unmark the check box to edit the focal point separately from the center point. This option applies to rectangular and sunburst gradients only.

6 Click **OK**.

## You can also

---

Save this gradient as a swatch that you can access later Click the **Add to Palette** button.

---

Apply the current materials to all tools On the Materials palette, mark the **All tools** check box. If you unmark this check box, the current materials are applied to the active tool only.

---



You can also move the center point by dragging the control needle or crosshairs shown in the gradient preview. If you unmark the **Link** check box, you can move the focal point by dragging the crosshairs on the gradient.

## To save an edited gradient

Edit workspace

1 On the Gradient page, click **Save**.

The New Gradient dialog box appears.

- 2 Enter a unique name for the gradient, and then click **OK**.

## To create a gradient

Edit workspace

- 1 On the Gradient page, click the **New Gradient** button .  
The **New Gradient** dialog box appears.
- 2 Type a name for the new gradient, and click **OK**.



The gradient is created with two markers at 0% and 100% that use the custom color.



For more information about gradients, see “Using gradients” on page 395.

## To rename a gradient

Edit workspace

- 1 On the Gradient page, click the **More Options** button , and choose **Resource Manager**.
- 2 In the Resource Manager dialog box, click the gradient that you want to rename.
- 3 Click **Rename**, type a name in the **Rename Resource** dialog box, and click **OK**.

## To delete a gradient



Edit workspace

- 1 On the Gradient page, click a gradient that you have created.
- 2 Click the **Delete Gradient** button .
- 3 When you are prompted to confirm the deletion, click **Yes**.

## Editing gradients

You can change the colors, transition points, and transparency of gradients. You can edit default gradients or create your own gradients. You can also rename, delete, and save gradients.

The colors, transition points, and transparency of a gradient are indicated by markers and midpoints on the Gradient Editor:

- Markers  — transparency markers appear along the top of the gradient bar. Color markers appear below the gradient bar.
- Midpoints  — indicate the positions where two colors are equally blended or the 50% opacity position. Each pair of markers has a midpoint that can be located anywhere between the markers.



*The Gradient Editor*

You can add and delete markers, as well as change the transparency, color, or position of a marker. You can also change the position of a midpoint.

***Important!*** *When you edit and save a default gradient, you permanently change the gradient. To maintain default gradients, save changes to a new gradient file. For more information about saving a gradient, see “To save an edited gradient” on page 398. For more information about restoring default settings, see “Installing and uninstalling Corel programs” on page 4.*

### To change the location of a marker or a midpoint

Edit workspace

- Drag the marker or midpoint to a new location on the Gradient Editor.



You can also click the marker or midpoint to select it, and then enter a value in the **Location** field.

## To add a marker

Edit workspace

- On the Gradient Editor, click a position under the gradient bar to add a color marker or click above the gradient bar to add a transparency marker.



The marker is created with the currently highlighted Fore, Back, or Custom color on the gradient bar.

## To delete a marker

Edit workspace

- On the Gradient Editor, drag a marker away from the gradient bar.

## To change the color for a marker

Edit workspace

- 1 On the Gradient Editor, click a marker below the gradient bar to select it.

The triangle at the top of the marker turns black.

- 2 Perform one of the following tasks, and click **OK**.

To

Do the following

---

To use the foreground color

Click the **Fore** button .

---

To use the background color

Click the **Back** button .

---

To use the currently defined custom color

Click the **User** button .

---

To	Do the following
To choose a new custom color	Click the swatch beside the <b>User</b> button and select from the Color page, or right-click to select from recently used colors.
To select a color from within the gradient itself	Click the gradient bar.



When you next apply the gradient that contains the foreground or background color, it uses the current foreground and background colors of the image (rather than the colors that you used to define the gradient). To create a gradient that always contains the same colors, use custom colors for all markers.

## To change the transparency of a marker

### Edit workspace

- 1 On the Gradient Editor, click the marker above the gradient bar to select it.
- 2 Type or set a value in the **Opacity** control.  
Values range from 0% (completely transparent) to 100% (opaque). At 100%, the underlying pixels are covered completely.

## Exporting and importing gradients

After creating a new gradient, you may want to export it to use in another program. The default gradients are stored in the GRD file format, which is commonly used in other applications.

You can also import gradients in the GRD file format.

### To export a gradient

Edit workspace

- 1 On the Gradient page, select the gradient that you want to export.
- 2 Click the **More Options** button , and choose **Export**.  
The Export dialog box appears.
- 3 Select the folder in which you want to save the gradient.  
The default gradients are stored in the **Gradients** folder within the Corel PaintShop Pro program folder.
- 4 In the **File name** field, type a name for the new gradient.
- 5 Click **Save**.

### To import a GRD gradient

Edit workspace

- 1 On the Gradient page, click the **More Options** button , and choose **Import**.  
The Import dialog box appears.
- 2 Select the folder that contains the gradient you want to import.  
All GRD files are listed in the folder.
- 3 Select the gradient's filename, and click **Open**.

## Using patterns

You can paint, draw, or fill patterns to create interesting effects. Corel PaintShop Pro includes many patterns that you can choose from (such as bricks, stained glass, and zebra stripes). You can also create patterns from an image or part of an image.

Patterns add creative flair to your images. You can apply patterned brush strokes, create objects with patterned fills or edges, and create patterned text. You can use patterns to create stationery or to create tiled images for Web pages. Patterns are especially helpful for projects that require interesting backgrounds such as CD covers, calendars, or greeting cards.

***Important!** Patterns are available for grayscale and 16 million-color images only. For more information about increasing the color depth of an image, see “Increasing the color depth of an image” on page 632.*

### What is the difference between patterns and textures?

On the Materials palette you can select both a pattern and a texture as part of a material. What is the difference between the two?

A pattern is an opaque, repeated image with specific colors and details. A pattern is a style, just like a solid color or gradient. Patterns do not use the current foreground or background colors. For example, if you select the Bricks pattern and apply brush strokes with the Paint Brush tool, each brush stroke paints the brick pattern.

A texture gives the effect of having textured canvas or paper. Textures use the current style (such as a solid color). For example, if you select the Crumpled Paper texture and if the foreground color is yellow, each brush stroke paints yellow with the texture of crumpled paper.



Textures can be applied at the same time you apply a solid color, gradient, or pattern. This means that you can have both a pattern and a texture selected at the same time.

For more information about patterns, refer to the Help.

## To apply the current pattern

Edit workspace

- On the Materials palette, click the **Pattern** button  on the **Style** drop-list for the **Foreground and Stroke Properties** box or the **Background and Fill Properties** box.

The most recently chosen pattern becomes active.

## To choose a pattern

Edit workspace

- 1 On the Materials palette, do one of the following:
  - To choose a foreground pattern, click the **Foreground and Stroke Properties** box.
  - To choose a background pattern, click the **Background and Fill Properties** box.The Material Properties dialog box appears.
- 2 Click the **Pattern** button.
- 3 On the Pattern page, click a pattern thumbnail.
- 4 Adjust the following controls:
  - **Angle** — specifies the angle (or direction) of the pattern, from 0 to 359 degrees
  - **Scale** — specifies the scale (from 10 to 250) of the image's actual size. At smaller values, the image is repeated more frequently throughout the pattern. At larger values, the image may be cropped, or may lose detail and become blurry.
- 5 Click **OK**.

## You can also

---

Save this pattern as a swatch that you can access later

Click the **Add to Palette** button.

---

Apply the current materials to all tools

On the Materials palette, mark the **All tools** check box. If you unmark this check box, the current materials are applied to the active tool only.

---



You can also change the angle of the pattern by dragging the control needle on the pattern preview on Pattern page.

## To use the active image or a selection as a pattern

Edit workspace

- 1 Open the image you want to use.
- 2 To select a part of the image as the pattern, make a selection in the image.

The pattern appears in the Pattern thumbnails on the Pattern page of the Material Properties dialog box.

## To save an image as a pattern

Edit workspace

- 1 Create an image in Corel PaintShop Pro or another application.
- 2 Save the image file in the Patterns folder of the Corel PaintShop Pro program folder, or in the My Documents/Corel PaintShop Pro/17.0/Patterns folder.

The pattern appears in the Pattern drop-list on the Pattern tab of the Material Properties dialog box.



To change the default location of pattern files, click the **More Options** button , and choose **File Location**. For more

information about setting file locations, see “Setting file locations” on page 691.

## Using textures

You can paint, draw, or fill with a texture to create the effect of a textured canvas or paper. You can use textures with the current color, gradient, or pattern for foreground and background strokes or fills. Corel PaintShop Pro includes many textures you can choose from, such as clouds, cracked cement, and old paper. You can also create your own textures from an image.

For information about the difference between patterns and textures, see “Using patterns” on page 404.

### To apply the current texture

Edit workspace

- On the Materials palette, click the **Texture** button  on the **Foreground and Stroke Properties** box or the **Background and Fill Properties** box.

The most recently chosen texture becomes active.

### To choose a texture

Edit workspace

- 1 On the Materials palette, do one of the following:
  - To choose a foreground texture, click the **Foreground and Stroke Properties** box.
  - To choose a background texture, click the **Background and Fill Properties** box.

The Material Properties dialog box appears.

- 2 Click the **Texture** button.
- 3 On the Texture page, mark the **Add Texture** check box.

- 4 Click a texture thumbnail.
- 5 Adjust the following controls for the texture:
  - **Angle** — specifies the angle (or direction) of the texture, from 0 to 359 degrees
  - **Scale** — specifies the scale (from 10 to 250) of the image's actual size. At smaller values, the image is repeated more frequently throughout the texture. At larger values, the image may be cropped or may lose detail and become blurry.

As you adjust these controls, the Current preview box displays the resulting material (the style plus the texture).
- 6 Click **OK**.

### You can also

---

Change the style of the material	Click the <b>Color</b> , <b>Gradient</b> , or <b>Pattern</b> button and adjust the controls.
Apply the current materials to all tools	On the Materials palette, mark the <b>All tools</b> check box. If you unmark this check box, the current materials are applied to the active tool only.

---



You can apply strokes or fills multiple times to gradually darken and fill in the texture.

You can also change the angle of the texture by dragging the control needle in the texture preview on the Pattern page.

### To save an image as a texture

Edit workspace

- 1 Create an image in Corel PaintShop Pro or another application.
- 2 Save the image as a BMP file in the Textures folder of the Corel PaintShop Pro program folder or in the My Documents/Corel PaintShop Pro/17.0/Textures folder.

The texture appears in the **Texture** thumbnails on the Texture page of the Material Properties dialog box.



The texture thumbnails include all the available files in the Textures folder of the Corel PaintShop Pro program folder.



To change the default location of texture files, click the **More Options** button , and choose **File Location**. For more information about setting file locations, see “Setting file locations” on page 691.

## Working with custom palettes and swatches



When you save swatches, you save them to a custom palette. You can create multiple palettes. For example, you can save all the colors and materials for a particular project on a custom palette. You can delete palettes that you no longer need.

### Swatches

Swatches are styles or materials created from colors, gradients, patterns, or textures that you can save to use again. Swatches offer a way to save your favorite colors, styles, and materials so that you can access them quickly when you are working on projects.



You can select, create, edit, delete, and rename swatches. You can also change the way swatches are displayed.

### To create a palette

- 1 On the Materials palette, click the **Swatches** tab .
- 2 Click the **More Options** button , and choose **New Palette**.
- 3 Type a name for your palette and click **OK**.



The palette is added to the drop-list above the swatches.

## To delete a palette

- 1 On the Materials palette, click the **Swatches** tab .
- 2 From the palette drop-list, choose the palette you want to delete.
- 3 Click the **More Options** button , and choose **Delete Palette**.

## To create a swatch

Edit workspace

- 1 On the Materials palette, click the **Swatches** tab .
- 2 Click the **Add to Palette** button .
- 3 In the **Add to Palette** dialog box, choose a palette and click **OK**, or click **New** to create a palette.
- 4 In the **New Swatch** dialog box, type a new for your swatch.  
This name appears as a tooltip when you hold the pointer over the swatch on the Materials palette.
- 5 Click **OK**.  
The swatch appears on the Materials palette.



You can also click the **More Options** button  on the Materials palette, and choose **New Swatch**.

## To select a swatch

Edit workspace

- 1 On the Materials palette, click the **Swatches** tab .
- 2 Do one of the following:
  - To select a swatch as the foreground material, click the swatch.
  - To select a swatch as the background material, right-click the swatch.

## To edit a swatch

Edit workspace



- 1 On the Materials palette, click the **Swatches** tab .
- 2 Double-click the swatch you want to edit.  
The Material Properties dialog box appears.
- 3 Edit the style (color, gradient, or pattern) or the texture for the material.
- 4 Click **OK**.



You can also click the swatch, click the **More Options** button , and then choose **Edit Swatch**.

## To delete a swatch from a palette

Edit workspace



- 1 On the Materials palette, click the **Swatches** tab .
- 2 Click the swatch you want to delete.
- 3 Click the **Remove from Palette** button .



You can also click the **More Options** button , and choose **Delete Swatch**.

## To rename a swatch

Edit workspace



- 1 On the Materials palette, click the **Swatches** tab .
- 2 Click the swatch you want to rename.
- 3 Click the **More Options** button , and choose **Rename Swatch**.

## To change how swatches are displayed

Edit workspace

- On the Materials palette, click the **Swatches** tab , and perform

a task from the following table.

To	Do the following
Select which swatch types are displayed	Click the <b>More Options</b> button  , choose <b>View</b> , and then choose the swatch type to display.
Change how swatches are sorted	Click the <b>More Options</b> button  , choose <b>Sort By</b> , and then choose <b>Style</b> or <b>Name</b> . By default, the swatches are sorted by style.
Change swatch thumbnail sizes	Click the <b>More Options</b> button  , and choose <b>Small Thumbnails</b> , <b>Medium Thumbnails</b> , or <b>Large Thumbnails</b> . Medium thumbnails are displayed by default.





Corel PaintShop Pro has many special effects that you can apply to your images, including 3D, artistic, illumination, reflection, and photographic effects. You can also add frames to your images, paint with images, or warp image areas to create unique effects.

This section presents the following topics:

- Choosing effects
- Applying 3D effects
- Applying Art Media effects
- Applying Artistic effects
- Applying environment maps and bump maps
- Applying Distortion effects
- Using the Displacement Map effect
- Applying Edge effects
- Applying Geometric effects
- Applying Illumination effects
- Applying Image effects
- Applying Photo effects
- Using Retro Lab
- Applying a gradient with the Graduated Filter effect
- Creating vintage-style photos with the Time Machine
- Applying film and filter effects to photos

- Applying Reflection effects
- Applying Texture effects
- Adding picture frames to images
- Creating your own effects
- Combining images
- Using the Picture Tube tool
- Warping images
- Working with deformation maps

## Choosing effects

You can choose effects by using the Effects menus, the Instant Effects palette, or the Effect Browser.

You can customize most effects by adjusting their settings in dialog boxes. The dialog boxes for applying effects contain several common features:

- The Before pane shows the original image, and the After pane lets you preview the image with the current settings applied.
- The Load Preset drop-list is set by default to Last Used. Presets let you apply the same settings to multiple images.

To save and load your own presets for effects, see “Using and creating presets” on page 721.

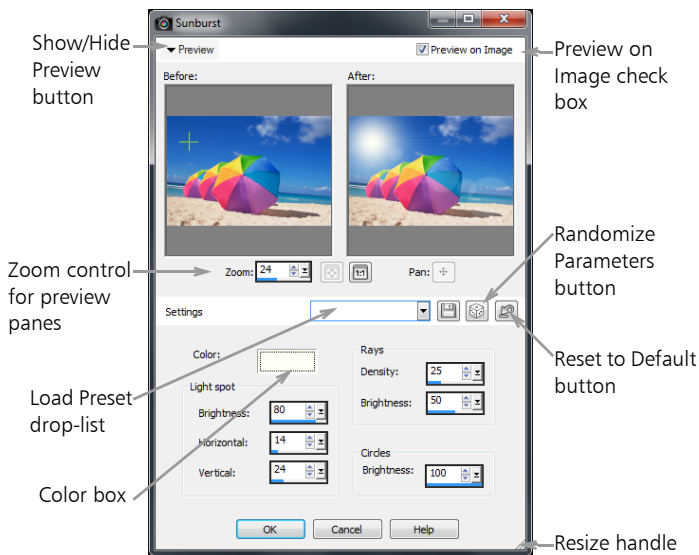

*An example of a dialog box for an effect.*

## Using the Instant Effects palette

You can quickly apply preset effects by using the Instant Effects palette. It is available in multiple workspaces and is an easy way to apply an effect when you don't want to adjust controls. When you create a preset in any effects dialog box, your preset automatically displays in the Instant Effects palette in the User Defined category.

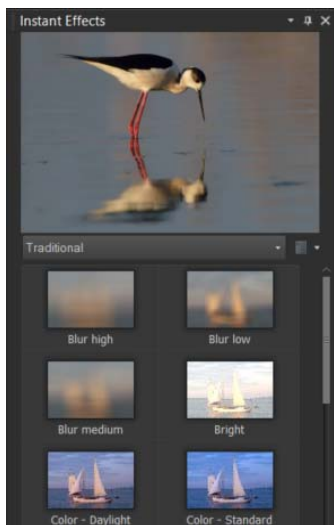

*Instant Effects palette*

## Using the Effect Browser

You can use the Effect Browser when you want to preview multiple effects before applying them to your image. The Effect Browser displays the presets that come with Corel PaintShop Pro as well as any that you create.

To display the thumbnail previews that you see in the Effect Browser, Corel PaintShop Pro applies an effect's default preset and any presets that you saved to the image. The preset is saved as a script in the file format for Corel PaintShop Pro (PspScript).

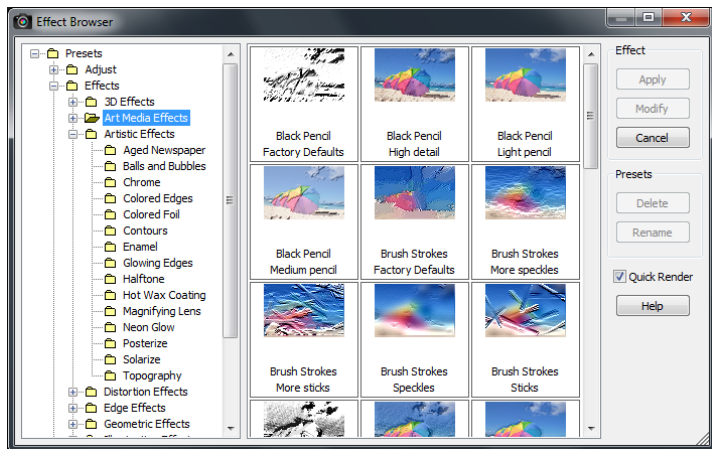

*The Effect Browser displays thumbnails that let you preview and choose effects.*

## To choose an effect from the Effects menu

Edit workspace

- 1 From the **Effects** menu, choose an effect category, and choose an effect. (For example, choose **Effects** ▶ **Distortion Effects** ▶ **Twirl**.)  
For most effects, a dialog box appears.
- 2 Specify the desired settings, or choose a preset from the **Load Preset** drop-list.  
You can preview the effect in the After pane.  
**Note:** Presets are not available for all effects.
- 3 Click **OK**.

### You can also

Save settings for reuse

Click the **Save Preset** button , type a name in the **Preset name** box, and click **OK**.

## You can also

---

Reset settings to default values	From the <b>Load Preset</b> drop-list, choose <b>Default</b> .
Limit an effect to a specific area	Make a selection before choosing the effect. For information about creating selections, see “Creating selections” on page 292.

---



## To choose an effect from the Instant Effects palette

- 1 In the Instant Effects palette, choose a category from the drop-list at the top of the palette.

If the Instant Effects palette is not displayed, choose **View ▶ Palettes ▶ Instant Effects**.

- 2 Double-click a thumbnail to apply the effect to the active image or the selected images.

Effects are cumulative; each time you double-click, the new effect is added to the previous effect.

To undo an effect, click the **Revert Current Editing** button  that appears on the palette (Manage workspace only), or click the **Undo** button  (Adjust and Edit workspaces). Note that the **Revert Current Editing** command reverts all unsaved effects.



In the Manage workspace, if you apply effects to an image that is in a RAW file format, a JPEG version of the image is created.

Custom presets (saved in any effect dialog box) appear in the User Defined category in the Instant Effects palette the next time that you launch the application.

## To choose an effect from the Effect Browser

Edit workspace

### 1 Choose **Effects** ▶ **Effect Browser**.

The Effect Browser appears.

### 2 From the hierarchical list in the left pane, do one of the following:

- To preview all effects applied to the image, click the **Presets** folder.
- To preview an effect category, click a subfolder of the **Effects** folder (for example, **3D Effects**, **Artistic Effects**, or **Photo Effects**).

Corel PaintShop Pro scans the selected folder and creates thumbnails of the image with each effect applied to it.

### 3 Click a thumbnail image to choose an effect preset.

### 4 Click **Apply**.

## You can also

---

Modify the selected preset

Click **Modify**, and adjust the settings in the dialog box for the effect.  
Note: This button is unavailable for effects that cannot be adjusted.

---

Resize the thumbnail preview

Choose **File** ▶ **Preferences** ▶ **General Program Preferences**, and click **Display and Caching** along the left side. In the **Effect browser thumbnails** group box, set a value in the **Size (Pixels)** control.

---

Limit an effect to a specific area

Make a selection before choosing the effect.  
For information about creating selections, see “Creating selections” on page 292.

---



The thumbnail previews displayed in the Effect Browser for a given effect include the default preset and any presets that you have saved. Presets are saved as script files (with a .PspScript filename extension) and are located in the Presets folder of the main program folder. You can change the location for storing preset files. For information about changing where preset files for effects are stored, see “To change file locations for resources” on page 691.

## Applying 3D effects

You can create images or selections that appear to have three dimensions by using the 3D effects. These effects are particularly useful for Web page images.

### Buttonize

Edit workspace

You can use the Buttonize effect to simulate square or rectangular buttons created from any selection, layer, or flattened image. With this effect, a 3D border is applied to makes the image or selection appear raised. You can access the Buttonize dialog box by choosing **Effects ▶ 3D Effects ▶ Buttonize**.

The Buttonize dialog box contains the following controls:

- **Height** — specifies the height of the button in pixels
- **Width** — specifies the width of the button in pixels
- **Opacity** — specifies the opacity of the shading applied to the edges of the button
- **Transparent** — produces a rounded effect by applying soft shading to the edges of the button



- **Solid** — produces sharp, distinct edges by applying a solid color to the edges of the button. To create a button with a colored edge, you can select the solid color before choosing the Buttonize command.
- **Color** — lets you apply a specific color to the edges of the button. You can click the color box to choose a color from the Color dialog box, or right-click the color box to choose a color from the Recent Colors dialog box.

## Chisel

Edit workspace

The Chisel effect adds a three-dimensional border around a selection or layer to make it appear as though it were cut out of stone. You can make the chiseled area transparent, allowing the underlying colors to show through, or you can create the chiseled area be from the background color. You can access the Chisel dialog box by choosing **Effects ▶ 3D Effects ▶ Chisel**.

The Chisel dialog box contains the following controls:

- **Size** — sets the size of the chiseled area in pixels
- **Transparent** — allows the underlying colors to show through
- **Solid color** — makes the chiseled area a solid color
- **Color** — lets you choose a background color for the chiseled area. You can click the color box to access the Color dialog box, or right-click the color box to access the Recent Colors dialog box.

## Cutout

Edit workspace

The Cutout effect creates the illusion that part of the image has been removed, allowing you to see through the image to a lower level.

Although a selection is not required, you can select part of the image before applying this effect. You can access the Cutout dialog box by choosing **Effects ▶ 3D Effects ▶ Cutout**.

The Cutout dialog box contains the following controls:

- **Vertical** — determines the vertical position of the interior and outline. Increase the setting to move the interior toward the bottom of the image, and decrease the setting to move the interior toward the top.
- **Horizontal** — determines the horizontal position of the interior and outline. Increase the setting to move the interior toward the right, and decrease the setting to move the interior toward the left.
- **Opacity** — controls the shadow's opacity
- **Blur** — sets the shadow's blur. As you increase the blur level, the shadow widens and its edges soften.
- **Shadow color** — lets you choose a shadow color. You can click the color box to choose a color from the Color dialog box, or right-click the color box to choose a color from the Recent Colors dialog box.
- **Fill interior with color** — fills the interior with the currently selected color. To choose a different color, you can click the color box to access the Color dialog box, or right-click the color box to access the Recent Colors dialog box. When unmarked, this check box fills the cutout with the image.

## Drop Shadow

Edit workspace

The Drop Shadow effect adds a shadow behind the current selection. It is most often used to give text a three-dimensional appearance.

To add a drop shadow to the entire image, you must first create white space around the image. You can do this by choosing the **Add Borders** command or the **Canvas Size** command from the **Image** menu. You can access the **Drop Shadow** dialog box by choosing **Effects ▶ 3D Effects ▶ Drop Shadow**.

The **Drop Shadow** dialog box contains the following controls:

- **Vertical** — determines the height of the shadow. You can also set the height by dragging the crosshair end of the offset indicator line in the left side of the dialog box.
- **Horizontal** — determines the width of the shadow. You can also set the width by dragging the crosshair end of the offset indicator line in the left side of the dialog box.
- **Opacity** — determines the shadow's opacity. As this value decreases, the drop shadow fades.
- **Blur** — determines the blur of the shadow
- **Color** — lets you choose the color of the drop shadow. You can click the color box to choose a color from the **Color** dialog box, or right-click the color box to choose a color from the **Recent Colors** dialog box.
- **Shadow on new layer** — places the drop shadow on a separate raster layer

You can apply an effect similar to the **Drop Shadow** effect by choosing the **Border with drop shadow** script from the **Script** drop-list on the **Script** toolbar.

## Inner Bevel

*Edit workspace*

You can apply the **Inner Bevel** effect to give a 3D appearance to the inside edges of a selection, or to an object surrounded by a

transparency. This effect does not increase the size of the object. When you use the Inner Bevel effect, you can set the options yourself, use one of the preset effects included with the program, or start with a preset effect and then modify its settings.

The Inner Bevel command is available when an image has a transparent background, has a colored background that contains a selection, or has a colored background and a layer. If a layer does not contain a selection or transparent area, the effect is applied to the edges of the layer. You can promote a selection, paste a selection as a new layer, or use the Eraser Tool to create a layer with transparency. You can access the Inner Bevel dialog box by choosing **Effects ▶ 3D Effects ▶ Inner Bevel**.

The Inner Bevel dialog box contains the following controls:

- **Bevel** — specifies the bevel shape
- **Width** — specifies the width in pixels
- **Smoothness** — controls the slope (sharpness) and thickness of the edge. As this value increases, the edges become more rounded. As it decreases, the edges appear thinner and steeper.
- **Depth** — controls the height of the edge. As this value increases, the edge becomes more pronounced.
- **Ambience** — adjusts the overall brightness of the image
- **Shininess** — determines how reflective the surface appears. A higher value produces a glossy image and makes the highlights more evident. A lower value makes the highlights diminish.
- **Color** — determines the color of the light shining on the image. To change the light color, you can click a color in the image, click the color box to access the Color dialog box, or right-click the color box to access the Recent Colors dialog box.

- **Angle** — affects which edges appear light and shadowed. The needle points to the direction of the light source, measured in degrees of rotation around the circle. To set the value, you can click in the circle, drag the needle, or set or type a number in the control.
- **Intensity** — adjusts the brightness of the directional light. Note that the Ambience value determines the brightness of the entire image before the Intensity value is applied.
- **Elevation** — shows the angle of elevation of the light source above the image. At a setting of 90 degrees, the light source is positioned directly overhead. As you lower the value, the light source moves closer to the image, producing longer shadows.

## Outer Bevel

Edit workspace

The Outer Bevel effect gives a selection a three-dimensional look by creating the appearance of raised edges. It expands the size of the selection by the width of the bevel.

You must first make a selection in the image before choosing the Outer Bevel command from the Effects menu. You can access the Outer Bevel effect dialog box by clicking **Effects ▶ 3D Effects ▶ Outer Bevel**.

The Outer Bevel dialog box contains the following controls:

- **Bevel** — specifies the bevel shape
- **Width** — specifies the width of the beveled edge in pixels
- **Smoothness** — controls the slope (sharpness) and thickness of the edge. As this value increases, the edges become more rounded. As it decreases, the edges appear thinner and steeper.
- **Depth** — controls the height of the edge. As this value increases, the edge becomes more pronounced.

- **Ambience** — adjusts the overall brightness of the image
- **Shininess** — determines how reflective the surface appears. A higher value produces a glossy image and makes the highlights more evident. A lower value makes the highlights diminish.
- **Color** — determines the color of the light shining on the image. To change the light color, you can click a color in the image, click the color box to access the Color dialog box, or right-click the color box to access the Recent Colors dialog box.
- **Angle** — affects which edges appear light and shadowed. The needle points to the direction of the light source, measured in degrees of rotation around the circle. To set the value, you can click in the circle, drag the needle, or set or type a number in the control.
- **Intensity** — adjusts the brightness of the directional light. Note that the Ambience value determines the brightness of the entire image before the Intensity value is applied.
- **Elevation** — shows the angle of elevation of the light source above the image. At a setting of 90 degrees, the light source is positioned directly overhead. As you lower the value, the light source moves closer to the image, producing longer shadows.

## Applying Art Media effects

You can apply Art Media effects to make an image look painted or drawn. You can simulate the use of traditional art media, including with pencil, charcoal, and chalk.

### Black Pencil

Edit workspace

The Black Pencil effect is similar to the Charcoal effect, but it uses thinner strokes and produces a more detailed image. You can access the Black Pencil dialog box by choosing **Effects ▶ Art Media Effects ▶ Black Pencil**.

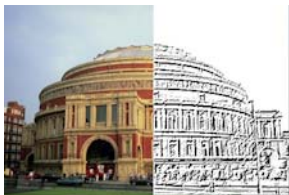

The Black Pencil dialog box contains the following controls:

- **Detail** — controls the number and darkness of the strokes
- **Opacity** — controls the strength of the effect. As the value increases, the image displays more of the effect and less of its original appearance.

### Brush Strokes

Edit workspace

The Brush Strokes effect makes your image look like an oil or watercolor painting. You can access the Brush Strokes dialog box by choosing **Effects ▶ Art Media Effects ▶ Brush Strokes**.



The Brush Stroke dialog box contains the following controls:

- **Softness** — determines the amount of blur in the image
- **Bristles** — specifies the number of bristles in the brush
- **Width** — controls the width of the brush
- **Opacity** — determines the strength of the effect
- **Length** — specifies the length of the brushstrokes
- **Density** — specifies the number of strokes in the image
- **Angle** — affects which edges appear light and shadowed. The needle points to the direction of the light source, measured in degrees of rotation around the circle. To set the value, you can click in the circle, drag the needle, or set or type a number in the control.
- **Color** — lets you choose a color for the light shining on the edges of the forms. You can click the color box to access the Color dialog box, or right-click the color box to access the Recent Colors dialog box.

## Charcoal

Edit workspace

The Charcoal effect is similar to the Black Pencil effect, but the thicker strokes produce an image containing less detail. You can access the Charcoal dialog box by choosing **Effects ▶ Art Media Effects ▶ Charcoal**.





The Charcoal effect dialog box contains the following controls:

- **Detail** — controls the number and darkness of the strokes
- **Opacity** — controls the strength of the effect. As the Opacity value increases, the image displays more of the effect and less of its original appearance.

## Colored Chalk

[Edit workspace](#)

The Colored Chalk effect uses the colors in the image to make the image appear drawn in colored chalk. Wider strokes appear with this effect than with the Colored Pencil effect.

You can access the Colored Chalk dialog box by choosing **Effects ▶ Art Media Effects ▶ Colored Chalk**.



The Colored Chalk dialog box contains the following controls:

- **Detail** — controls the number and darkness of the strokes

- **Opacity** — controls the strength of the effect. As the Opacity value increases, the image displays more of the effect and less of its original appearance.

You can produce an effect similar to the Colored Chalk effect by using the Chalk tool found on the Tools toolbar.

## Colored Pencil

Edit workspace

The Colored Pencil effect uses the colors in the image to make it appear drawn in colored pencil. The effect is similar to the Colored Chalk effect, but it uses thinner strokes. You can access the Colored Pencil dialog box by choosing **Effects ▶ Art Media Effects ▶ Colored Pencil**.



The Colored Pencil dialog box contains the following controls:

- **Detail** — controls the number and darkness of the strokes
- **Opacity** — controls the strength of the effect. As the Opacity value increases, the image displays more of the effect and less of its original appearance.

## Pencil

Edit workspace

The Pencil effect enhances and colors the edges in the image to make the image look like a pencil drawing. You can access the Pencil dialog box by choosing **Effects ▶ Art Media Effects ▶ Pencil**.



The Pencil dialog box contains the following controls:

- **Luminance** — adjusts the overall brightness of the image
- **Blur** — determines the softness of the image. As you increase the value, the image becomes less sharp.
- **Color** — lets you choose a color for the background, or non-edge area, of the image. To change the light color, you can click a color in the image, click the color box to access the Color dialog box, or right-click the color box to access the Recent Colors dialog box.
- **Intensity** — controls the contrast between the background and the edges. As you increase the contrast, more detail appears.

## Applying Artistic effects

You can apply Artistic effects to age a photograph or to create a variety of artistic results. Balls and Bubbles, Colored Foil, and Solarize are among the effects included in this group.

### Aged Newspaper

Edit workspace

The Aged Newspaper effect applies a warm brown tone and blurs the image so that it resembles a newspaper that has yellowed with age. This effect works best with images that contain text.

For best results, you should convert your image into grayscale and then increase the color depth to 16 million colors before applying this effect.

You can access the Aged Newspaper dialog box by clicking **Effects ▶ Artistic Effects ▶ Aged Newspaper**.



The Aged Newspaper dialog box contains the following control:

- **Amount to age** — lets you select the intensity of the effect by dragging the slider or typing a number in the box.

## Balls and Bubbles

Edit workspace

The Balls and Bubbles effect lets you create sophisticated multilayered spherical objects. You can use environment maps and bump maps with this effect. For more information, see “Applying environment maps and bump maps” on page 448.

You can access the Balls and Bubbles dialog box by choosing **Effects ▶ Artistic Effects ▶ Balls and Bubbles**.



The Balls and Bubbles dialog box has four tabs: Shape, Surface, Maps, and Illumination.

The **Shape** page contains the following controls:

- **Automatic multiple balls or bubbles** — applies an assortment of bubbles to your image. This option also lets you specify the coverage, average size, size variation, and type of the bubbles.
- **Coverage** — determines how much of the canvas is filled with bubbles or balls
- **Average size** — sets a standard size for the bubbles or balls
- **Size variation** — determines how dissimilar in size the largest and smallest bubbles can be. A value of 0 forces all the bubbles to be uniform. A value of 100 allows the bubbles be as random as possible.
- **Balls or Bubbles type** — lets you choose nonintersecting, intersecting, or overlapping balls and bubbles
- **Randomize** — randomly sets the size and placement of the bubbles
- **Seed** — determines the strength of the effect
- **Single ball or bubble** — applies a single ball or bubble instead of multiple ones
- **Maximum possible size** — makes a single ball or bubble the largest possible size. You can choose another size by dragging a bounding box in the Before pane.

The **Surface** page contains the following controls:

- **Material** — lets you choose the color, gradient, and pattern for the surface material of the balls and bubbles. You can combine each of these elements with choices from the Textures panel of the Material Properties dialog box. Note that when you select the Textures option, the material becomes semitransparent.
- **Opacity** — sets the maximum opacity for the object. The default is 15% for bubbles. A solid object would have a setting of 100%.

- **Shininess** — determines how the light is absorbed or reflected from the surface. This control interacts with the setting for the Gloss control.
- **Gloss** — determines how the light is absorbed or reflected from the surface. This control interacts with the setting for the Shininess control.

The **Maps** page contains the following controls:

- **Bump map** — lets you add surface texture to your balls and bubbles by activating the bump map controls
- **Smoothness** — determines the smoothness of the effect
- **Depth** — determines the depth of the effect. The greater the value, the more recessed the black areas on the map appear and the more raised the white areas appear. Negative values reverse this effect.
- **Fit bump map** — automatically resizes the map to wrap around the sphere. You can unmark the check box to change the size of the map.
- **Size** — lets you set the size of the map when the **Fit bump map** check box is unmarked.
- **Environment map** check box — lets you add surface details to your balls and bubbles by activating the environment map controls
- **Opacity** — controls the strength of the effect. As the opacity increases, the image displays more of the effect and less of its original appearance.
- **Environment map** option and swatch — let you choose an image from the Environment Maps folders or the current image
- **Current Image** — wraps the current image around the spherical objects

- **Diffraction map** — wraps a rainbow-style light pattern around the spherical objects. To change the pattern, adjust the **Fringe spacing** and **Type** settings.
- **Type** — sets randomness of the origins, direction, and paths of the bands

The **Illumination** page contains the following controls:

- **Maximum** — sets the maximum value for the overall lighting of the object
- **Minimum** — sets the minimum value for the overall lighting of the object
- **Add** and **Remove** buttons and **Lights** menu — let you add or remove individual lights. By default, a single light with a highlight appears just above and to the left of the center.
- **Position** — lets you move the focus of the light by clicking on the highlight and dragging it to a new location
- **Back light** — redirects the light so that it comes from behind the object. You can drag back lights, but they are visible only around the perimeter of the sphere.
- **Bubble light** — scatters the illumination as though it were passing through a semitransparent object. This option is available only when the **Opacity** setting is less than 100%.
- **Color** — lets you choose the color for each light. The default color is white.
- **Highlight size** — lets you control the size of each highlight

## Chrome

Edit workspace

The Chrome effect gives an image a metallic look. It works best with images that have distinct areas of contrast. You can access the Chrome dialog box by choosing **Effects ▶ Artistic Effects ▶ Chrome**.

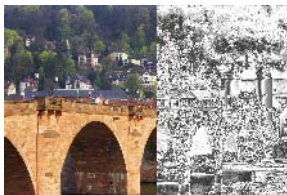

The Chrome dialog box contains the following controls:

- **Flaws** — sets the number of creases, or folds. Each fold is a transition between light and dark areas.
- **Brightness** — sets the brightness of the chrome
- **Use original color** — applies the image's color for the chrome
- **Color** — makes the chrome a uniform color. You can choose a color by unmarking the Use original color check box, and then clicking the color box to access the Color dialog box. You can also right-click the color box to access the Recent Color dialog box. The default color is white.

## Colored Edges

Edit workspace

The Colored Edges effect makes an image look retouched by enhancing and coloring its edges. You can access the Colored Edges dialog box by choosing **Effects ▶ Artistic Effects ▶ Colored Edges**.





The Colored Edges dialog box contains the following controls:

- **Luminance** — adjusts the overall brightness of the image
- **Blur** — determines the softness of the image. As you increase the value, the image becomes less sharp.
- **Color** — lets you choose a color for the edges. To change the edge color, you can click a color in the original image, click the color box to access the Color dialog box, or right-click the color box to access the Recent Colors dialog box.
- **Intensity** — controls the intensity of the effect. As you increase the value, more edges are colored, and more color is applied to the edges.

## Colored Foil

Edit workspace

The Colored Foil effect adds a sculpted look to the edges and applies several colors to an image. You can access the Colored Foil dialog box by choosing **Effects** ▶ **Artistic Effects** ▶ **Colored Foil**.



The Colored Foil dialog box contains the following controls:

- **Blur** — determines the softness of the image. As you increase the value, the image becomes less sharp.
- **Detail** — controls the amount of the effect applied. As you increase the value, color is applied to more areas of contrast.
- **Color** — lets you choose a color for the light shining on the image. To change the light color, you can click a color in the original image, click the color box to access the Color dialog box, or right-click the color box to access the Recent Colors dialog box.
- **Angle** — affects which edges appear light and shadowed. The needle points to the direction of the light source, measured in degrees of rotation around the circle. To set the value, you can click in the circle, drag the needle, or set or type a number in the control.

## Contours

Edit workspace

The Contours effect reproduces the look of a topographical map by covering the image with contour lines. You can access the Contours dialog box by choosing **Effects ▶ Artistic Effects ▶ Contours**.



The Contours dialog box contains the following controls:

- **Luminance** — adjusts the overall brightness of the image
- **Blur** — determines the softness of the image. As you increase the value, the image becomes less sharp.

- **Detail** — controls where the color is applied. As you increase the value, the color is applied to more areas of contrast.
- **Intensity** — controls the amount of color applied to each area. As you increase the value, more color is applied.
- **Color** — lets you choose a color for the contour lines. To change the color, you can click a color in the original image, click the color box to access the Color dialog box, or right-click the color box to access the Recent Colors dialog box.

## Enamel

Edit workspace

The Enamel effect applies the look of a shiny, hard surface to the image. You can access the Enamel dialog box by clicking **Effects ▶ Artistic Effects ▶ Enamel**.



The Enamel dialog box contains the following controls:

- **Blur** — determines the softness of the image. As you increase the value, the image becomes less sharp.
- **Detail** — controls the scale of the relief. Low values produce fewer levels of relief and a softer, less defined effect.
- **Density** — controls the number of areas of relief. Low values produce fewer larger areas and a softer look. Higher values add relief to smaller areas, producing a denser effect.
- **Angle** — affects which edges appear light and shadowed. The needle points to the direction of the light source, measured in

degrees of rotation around the circle. To set the value, you can click in the circle, drag the needle, or set or type a number in the control.

- **Color** — lets you choose a color for the light shining on the edges of the forms. To change the light color, you can click a color in the original image, click the color box to access the Color dialog box, or right-click the color box to open the Recent Colors dialog box.

## Glowing Edges

Edit workspace

The Glowing Edges effect makes the image appear to have been created from neon tubes. The edges in an image become brightly colored, while the remaining portions turn black. You can access the Glowing Edges dialog box by choosing **Effects ▶ Artistic Effects ▶ Glowing Edges**.



The Glowing Edges dialog box contains the following controls:

- **Intensity** — sets the brightness of the edges. As you increase the value, more edges are displayed, and they become brighter.
- **Sharpness** — controls the tightness of the edges. As you increase the value, the edges narrow and become more defined.

## Halftone

Edit workspace

The Halftone effect applies a series of dots to the image, rather than a continuous tone. Halftone images can be printed easily and are therefore typically used in newspapers and magazines. You can choose different sizes, colors, and shapes for the Halftone effect. Larger dots produce darker, more dense areas of the image, whereas smaller dots produce lighter areas. You can access the Halftone dialog box by choosing **Effects ▶ Artistic Effects ▶ Halftone**.



The Halftone dialog box contains the following controls:

- **Halftone pattern** — lets you choose a line, round, or square pattern
- **Size** — lets you choose a size for the pattern cell
- **Screen angles** — lets you choose the angles for the screen. In the case of a grayscale image, you can choose only one angle. For an RGB image, you can choose an angle for each color channel.
- **Use as overlay** — lets you adjust the strength of the effect and apply blending
- **Blend mode** — lets you choose from a wide variety of blending effects
- **Opacity** — controls the strength of the effect. As the opacity increases, the image displays more of the effect and less of its original appearance.

- **RGB** — processes the red, green, and blue channels independently
- **Greyscale** — lets you choose pattern and background colors
- **Ink** — lets you choose the color for the pattern
- **Background** — lets you choose the color of the background
- **Transparent** — makes the original image visible in the effect background. Unmark this check box if you want to choose a color for the background.

## Hot Wax Coating

[Edit workspace](#)

The Hot Wax Coating effect makes the image appear coated in a layer of hot wax. The current Foreground/Stroke color is used for the wax. You can apply the Hot Wax Coating effect by choosing **Effects ▶ Artistic Effects ▶ Hot Wax Coating**.

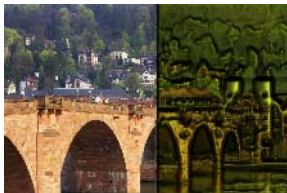

## Magnifying Lens

[Edit workspace](#)

The Magnifying Lens effect lets you bring attention to a portion of your image by placing a magnifying lens over it. You can use environment maps and bump maps with this effect. For more information, see “Applying environment maps and bump maps” on page 448.

The Magnifying Lens dialog box has four tabs: Shape, Properties, Illumination, and Frame. You can access the Magnifying Lens dialog box by clicking **Effects ▶ Artistic Effects ▶ Magnifying Lens**.



The **Shape** page contains the following controls:

- **Magnification** — sets the strength of the magnification
- **Refraction** — controls the degree of refractive distortion
- **Defocus** — blurs the magnified image
- **Darkness** — sets the darkness of the image surrounding the magnified frame
- **Spherical** — uses a round magnifying lens
- **Cylindrical vertical** — uses a cylindrical lens to produce a magnified image that is wider than it is long
- **Cylindrical horizontal** — uses a cylindrical lens to produce a magnified image that is longer than it is wide

The **Properties** page contains the following controls:

- **Material** swatch — lets you choose the colors, gradients, and patterns for the surface material of the magnified image. You can combine each of these elements with choices from the Textures panel of the Material Properties dialog box. Note that when you select the Textures option, the material becomes semitransparent.
- **Opacity** box in the Material panel — sets the maximum opacity for the surface material. At higher values, you can see more of the material and less of the original image.

- **Shininess** — determines how the light is absorbed or reflected from the surface. This control interacts with the setting for the Gloss control.
- **Gloss** — determines how the light is absorbed or reflected from the surface. This control interacts with the setting for the Shininess control.
- **Environment map** check box — lets you add surface details to your magnified image by activating the Environment map controls
- **Opacity** box in the Environment Map panel — sets the opacity of the environment map that covers the magnified image. Higher values let you see more of the environment map.
- **Current image** — uses the current image as an environment map
- **Environment map** option and swatch — let you choose an image from the Environment Maps folders

The **Illumination** page contains the following controls:

- **Maximum** — sets the maximum value for the overall lighting of the object
- **Minimum** — sets the minimum value for the overall lighting of the object
- **Add** and **remove** buttons and **Lights** menu — let you add or remove individual lights. By default, a single light with a highlight appears just above and to the left of the center.
- **Position** — lets you move the focus of the light by clicking on the highlight and dragging it to a new location
- **Back light** — redirects the light so that it comes from behind the object. You can drag back lights, but they are visible only around the perimeter of the sphere.
- **Color** — lets you choose the color for each light. The default color is white.



- **Highlight size** — lets you control the size of each highlight

The **Frame** page contains the following controls:

- **Circular** — provides a curved frame edge
- **Rounded square** — provides a rounded square frame edge
- **Thickness** — specifies the thickness of the frame
- **Material** — lets you choose the material for the frame
- **Color** — lets you choose the color for the frame

## Neon Glow

Edit workspace

The Neon Glow effect gives an image a three-dimensional appearance by applying a neon effect and heightening the contrast of the edges. You can access the Neon Glow dialog box by choosing **Effects ▶ Artistic Effects ▶ Neon Glow**.



The Neon Glow dialog box contains the following controls:

- **Detail** — controls the number of colors and the brightness of colors. Increasing the detail level increases the number of strokes and the strength of the contrast between light and dark areas.
- **Opacity** — controls the strength of the effect. As the opacity increases, the image displays more of the effect and less of its original appearance.

## Posterize

Edit workspace

The Posterize effect reduces the number of bits for each color channel, which decreases the number of colors and levels of lightness in the image or selection. The result is a flatter-looking image that has bands of color rather than smooth gradients. You can access the Posterize dialog box by choosing **Effects ▶ Artistic Effects ▶ Posterize**.



The Posterize dialog box has the following control:

- **Levels** — divides the range of lightness levels (from 2 to 255) into a chosen number of equal increments. As the number of levels decreases, the image or selection appears flatter.

## Solarize

Edit workspace

The Solarize effect lets you convert all colors in an image or selection above a specific lightness value into their inverse on the scale from 1 to 254. The threshold level is the lightness value above which all colors are inverted. You can access the Solarize dialog box by choosing **Effects ▶ Artistic Effects ▶ Solarize**.



The Solarize dialog box contains the following control:

- **Threshold** — sets the threshold level. As the level increases, increasingly lighter colors are inverted.

## Topography

[Edit workspace](#)

The Topography effect gives an image a three-dimensional look so that the image appears to have been created from a system of terraces. You can access the Topography dialog box by choosing **Effects ▶ Artistic Effects ▶ Topography**.



The Topography dialog box contains the following controls:

- **Width** — controls the size of each terrace or layer
- **Density** — sets the number of terraces
- **Angle** — affects which edges appear light and shadowed. The needle points to the direction of the light source, measured in degrees of rotation around the circle. To set the value, you can click in the circle, drag the needle, or set or type a number in the control.

- **Color** — lets you choose a color for the light shining on the sides of the terraces. To change the light color, you can click a color in the original image, click the color box to access the Color dialog box, or right-click the color box to access the Recent Colors dialog box.

## Applying environment maps and bump maps

When using the Balls and Bubbles effect or the Magnifying Lens effect, you can apply optional environment maps or bump maps. An environment map lets you add reflections, surface detail, and nuances. A bump map treats the source image like a three-dimensional surface, in which pixel luminance values determine height.

### To apply an environment map

Edit workspace

- 1 Choose **Effects ▶ Artistic Effects**, and select one of the following effects:
  - **Balls and Bubbles**
  - **Magnifying Lens**
- 2 Do one of the following:
  - In the Balls and Bubbles Effect dialog box, click the **Maps** tab.
  - In the Magnifying Lens Effect dialog box, click the **Properties** tab.
- 3 Mark the **Environment map** check box.

### To apply a bump map

Edit workspace

- 1 Choose **Effects ▶ Artistic Effects ▶ Balls and Bubbles**.  
The Balls and Bubbles Effect dialog box appears.
- 2 Click the **Maps** tab.

3 Mark the **Bump map** check box.

## Applying Distortion effects

You can apply Distortion effects to an image and produce interesting results. Curlicues, Pixelate, and Warp are examples of effects that let you distort your image.

### Curlicues

Edit workspace

The Curlicues effect turns an image into a series of rows and columns composed of curls. You can access the Curlicues dialog box by choosing **Effects ▶ Distortion Effects ▶ Curlicues**.



The Curlicues dialog box contains the following controls:

- **Number of columns** — sets the number of curls in each row
- **Number of rows** — sets the number of curls in each column. If the number of columns is set at 5 and the number of rows is set at 4, then each of the four rows will have five curlicues.
- **Symmetric** — links the Rows and Columns values so that changing one changes the other. Mark this check box if you want an equal number of rows and columns.
- **Radius** — sets the radius of the curls. This value is a percentage of the smallest dimension — either the column width or the row height.

- **Strength** — controls the amount of rotation of each curl
- **Clockwise** — sets the direction of the curls

## Displacement Map

You can warp, or displace, one image based on the contents of another image. For information about using the Displacement Map effect, see “Using the Displacement Map effect” on page 459.



## Lens Distortion

[Edit workspace](#)

The Lens Distortion effect simulates barrel, fisheye, or pincushion distortion in an image. You can access the Lens Distortion dialog box by choosing **Effects ▶ Distortion Effects ▶ Lens Distortion**.



The Lens Distortion dialog box contains the following controls:

- **Horizontal** — positions the center of the distortion horizontally in the image. Increasing the value moves the center of the distortion to the right. Decreasing the value moves the center of the distortion to the left.

- **Vertical** — positions the center of the distortion vertically in the image. Increasing the value moves the center of the distortion toward the bottom. Decreasing the value moves the center of the distortion toward the top.
- **Distortion type** — lets you specify whether to choose Barrel, Fisheye, Fisheye (Spherical), or Pincushion distortion
- **Strength** — determines the strength of the Barrel or Pincushion effects
- **Field of view** — determines the strength of the Fisheye or Fisheye (Spherical) effect
- **Wrap** — makes the image appear as though it were a tile repeating in each direction
- **Repeat** — finds the edge pixel of each side and repeats it outward infinitely
- **Color** — lets you choose a color to represent out-of-bounds pixels. You can click the color box to access the Color dialog box, or right-click the color box to access the Recent Colors dialog box.
- **Transparent** — makes out-of-bounds pixels transparent (available only with layered images).

## Pinch

Edit workspace

The Pinch effect is a deformation that makes the image or selection appear pinched by pushing the contents in toward the center. You can access the Pinch dialog box by choosing **Effects ▶ Distortion Effects ▶ Pinch**.



The Pinch dialog box contains the following control:

- **Strength** — determines how much of the image is pushed toward the center

## Pixelate

Edit workspace

The Pixelate effect divides an image into rectangles or squares of a specified size. You can access the Pixelate dialog box by choosing **Effects ▶ Distortion Effects ▶ Pixelate**.



The Pixelate effect dialog box contains the following controls:

- **Block width** — sets the width of the blocks in pixels
- **Block height** — sets the height of the blocks in pixels
- **Symmetric** — creates square blocks. You can create rectangular blocks by clearing the check box.



## Polar Coordinates

Edit workspace

The Polar Coordinates effect changes pixels by mapping them from Cartesian to polar coordinates, or from polar to Cartesian coordinates. You can access the Polar Coordinates dialog box by choosing **Effects** ▶ **Distortion Effects** ▶ **Polar Coordinates**.



The Polar Coordinates dialog box contains the following controls:

- **Rectangular to polar** — maps pixels from Cartesian to polar coordinates
- **Polar to rectangular** — maps pixels from polar to Cartesian coordinates
- **Wrap** — makes the image appear as though it were a tile repeating in each direction
- **Repeat** — finds the edge pixel of each side and repeats it outward infinitely
- **Color** — lets you choose a color to represent out-of-bounds pixels. You can click the color box to access the Color dialog box, or right-click the color box to access the Recent Colors dialog box.
- **Transparent** — makes out-of-bounds pixels transparent.

## Punch

[Edit workspace](#)

The Punch effect is a deformation that makes an image or selection appear punched out from behind so that the contents in the center expand toward the outer edges. You can access the Punch dialog box by choosing **Effects ▶ Distortion Effects ▶ Punch**.



The Punch dialog box contains the following control:

- **Strength** — determines how much of the image is pushed out toward the edges

## Ripple

[Edit workspace](#)

The Ripple effect is a deformation that creates concentric rings similar to those produced by dropping a pebble in water. You can access the Ripple dialog box by choosing **Effects ▶ Distortion Effects ▶ Ripple**.



The Ripple dialog box contains the following controls:

- **Horizontal** — moves the central point of the ripples. The value is a percentage of the width of the image or selection. The default position, 50, corresponds to the center of the image or selection.
- **Vertical** — moves the central point of the ripples. The value is a percentage of the height of the image or selection. The default position, 50, corresponds to the center of the image or selection.
- **Amplitude** — controls the amplitude of each ripple, or the distance from the trough to the crest
- **Wavelength** — controls the distance from the crest of one ripple to the crest of the next
- **Color** — lets you choose a color to represent out-of-bounds pixels. You can click the color box to access the Color dialog box, or right-click the color box to access the Recent Colors dialog box.
- **Transparent** — makes out-of-bounds pixels transparent (available only with layered images)

## Spiky Halo

Edit workspace

The Spiky Halo effect is a deformation that you can use to create a radical pattern of waves or ripples. You can access the Spiky Halo dialog box by choosing **Effects ▶ Distortion Effects ▶ Spiky Halo**.



The Spiky Halo dialog box contains the following controls:

- **Horizontal** — moves the central point of the ripples. The value is a percentage of the width of the image or selection. Negative values

move the halo to the left, and positive values move the halo to the right.

- **Vertical** — moves the central point of the ripples. The value is a percentage of the height of the image or selection. Negative values move the halo up, and positive values move the halo down.
- **Amplitude** — sets the apparent height of the waves. Lower values produce smoother ripples.
- **Frequency** — sets the number of rays for each quarter-circle
- **Radius** — sets the distance of the waves from the center. Lower numbers cause the waves to begin closer to the center.
- **Color** — lets you choose a color to represent out-of-bounds pixels. You can click the color box to access the Color dialog box, or right-click the color box to access the Recent Colors dialog box.
- **Transparent** —makes out-of-bounds pixels transparent (available only with layered images)

## Twirl

Edit workspace

The Twirl effect distorts an image by twisting or whirling it around its center. You can twirl an image up to two rotations in either direction. You can access the Twirl dialog box by choosing **Effects ▶ Distortion Effects ▶ Twirl**.



The Twirl dialog box has the following control:

- **Degrees** — sets the direction and amount of twirl. Positive values create a clockwise twirl; negative values create a counter-clockwise twirl.

## Warp

Edit workspace

The Warp effect makes a circular area of the image appear at a higher or lower zoom level. The area is distorted as if viewed through a convex or concave lens. You can access the Warp dialog box by choosing **Effects ▶ Distortion Effects ▶ Warp**.



The Warp dialog box has the following controls:

- **Horizontal** — moves the central point of the warp horizontally. The value is a percentage of the width of the image or selection. Negative values move the center to the left, and positive values move the center to the right.
- **Vertical** — moves the central point of the warp vertically. The value is a percentage of the height of the image or selection. Negative values move the center up, and positive values move the center down.
- **Size** — sets how far the effect continues from the center. The value is a percentage of the image size. As you lower the number, less of the image appears distorted.

- **Strength** — sets the level of the distortion. Positive values make the distorted image area appear closer, and negative values make it appear farther away.

## Wave

Edit workspace

The Wave effect distorts an image by creating undulating lines. You can determine the amount of distortion by setting the size of the wave. You can access the Wave dialog box by choosing **Effects ▶ Distortion Effects ▶ Wave**.



The Wave dialog box contains the following controls:

- **Amplitude** (in the Horizontal displacement group box) — sets the distance from the trough to the crest for horizontal ripples
- **Amplitude** (in the Vertical displacement group box) — sets the distance from the trough to the crest for vertical ripples
- **Wavelength** (in the Horizontal displacement group box) — sets the distance from the crest of one horizontal ripple to the crest of the next
- **Wavelength** (in the Vertical displacement group box) — sets the distance from the crest of one vertical ripple to the crest of the next
- **Color** — lets you choose a color to represent out-of-bounds pixels. You can click the color box to access the Color dialog box, or right-click the color box to access the Recent Colors dialog box.

- **Transparent** — makes out-of-bounds pixels transparent (available only with layered images)

## Wind

Edit workspace

The Wind effect blurs an image to make it look as though it has been blown by wind coming from either the left or the right. You can access the Wind dialog box by choosing **Effects ▶ Distortion Effects ▶ Wind**.



The Wind dialog box contains the following controls:

- **Wind direction** group box — lets you choose **From left** or **From right** for the wind direction
- **Wind strength** — controls the strength of the deformation. Increasing the strength increases the blurriness of the image.

## Using the Displacement Map effect

You can warp, or displace, one image (the displacement map) based on the contents of another image (the source image). For example, you can apply text to an image that depicts something with an uneven surface, making it look like the text was there all along.

### To apply a displacement map

Edit workspace

- 1 Open the images you want to use as the displacement map and the source image.

- 2 Make the source image the active image.
- 3 Choose **Effects ▶ Distortion Effects ▶ Displacement Map**.
- 4 In the **Displacement map** group box, click the image drop-list, and choose an image to use as the displacement map.

If the displacement map and the source image don't have the same dimensions, choose either the **Stretch map to fit image** option, or the **Tile map to cover image** option.

- 5 Type or set a value in the **Blur** control to set the amount of blur to apply to the displacement map.

Lower values produce jittery, pointillistic effects; higher values produce smoother warping effects.

- 6 In the **Displacement properties** group box, choose one of the following options:

- **2D offsets** — uses the red and green channels to displace the image
- **3D surface** — treats the source image as though it were a 3D surface in which pixel luminance values determine height

- 7 Type or set a value in the **Intensity** control to set the amount of displacement.

Lower values result in less change to the image; higher values yield greater deformation.

- 8 Type or set a value in the **Rotation** control to determine the rotation of the displacement data.

- 9 In the **Edge mode** group box, choose one of the following options to determine how to handle out-of-bounds displacement:

- **Wrap** — treats the image as though it were a tile repeating in each direction
- **Repeat** — finds the edge pixel of each side and repeats it outward infinitely



- **Color** — lets you choose a color to represent out-of-bounds pixels. You can click the color box to access the Color dialog box, or right-click the color box to access the Recent Colors dialog box.
- **Transparent** — makes out-of-bounds pixels transparent (available only with layered images)

## Applying Edge effects

Edge effects are applied to the edges in an image or selection. You can dilate, enhance, erode, find, and trace the edges in an image to create interesting results.

***Important!** These effects work on grayscale and 16 million-color (24-bit) images only. For more information about increasing the color depth of an image, see “Increasing the color depth of an image” on page 632.*

### Dilate

Edit workspace

The Dilate effect enhances the light areas of an image or selection. You can apply the Dilate effect by choosing **Effects ▶ Edge Effects ▶ Dilate**.



## Enhance

Edit workspace

The Enhance effect increases the contrast along the edges in an image. You can apply the Enhance effect by choosing **Effects ▶ Edge Effects ▶ Enhance**.



## Enhance More

Edit workspace

The Enhance More effect applies a stronger contrast to the edges in an image than the Enhance effect does. You can apply the Enhance More effect by choosing **Effects ▶ Edge Effects ▶ Enhance More**.



## Erode

Edit workspace

The Erode effect enhances the dark areas in an image. You can apply the Erode effect box by choosing **Effects ▶ Edge Effects ▶ Erode**.



## Find All

Edit workspace

The Find All effect enhances the contrast between light and dark in an image by darkening the image and then highlighting the edges. You can apply the Find All Edges effect by choosing **Effects ▶ Edge Effects ▶ Find All**.



## Find Horizontal

Edit workspace

The Find Horizontal effect enhances the contrast between light and dark in an image by darkening the image and then highlighting the horizontal edges. You can apply the Find Horizontal edges by choosing **Effects ▶ Edge Effects ▶ Find Horizontal**.



## Find Vertical

Edit workspace

The Find Vertical effect enhances the contrast between light and dark in an image by darkening the image and then highlighting the vertical edges. You can apply the Find Vertical edges effect by choosing **Effects** ▶ **Edge Effects** ▶ **Find Vertical**.



## High Pass

Edit workspace

The High Pass effect emphasizes color transitions between highlight and shadow colors. You can use it with other imaging operations to create or enhance special effects such as embossing or line-drawing effects. The High Pass effect preserves the contrast of edges and areas of high detail while leaving the rest of the image a neutral gray. You can access the High Pass dialog box by choosing **Effects** ▶ **Edge Effects** ▶ **High Pass**.



The High Pass dialog box contains the following controls:

- **Radius** — sets the radius of the blur effect as a percentage
- **Desaturate** — removes all color, leaving a gray result. The results of the High Pass effect are close to monochrome, even when this check box is unmarked. You can mark this check box, however, to prevent subtle color shifts that can occur when sharpening is applied to an image. This option works by removing any color artifacts that remain after sharpening.

## Trace Contour

Edit workspace

The Trace Contour effect traces a series of single-pixel lines around areas of contrast and turns the remaining pixels white. You can apply the Trace Contour effect by choosing **Effects** ▶ **Edge Effects** ▶ **Trace Contour**.



## Applying Geometric effects

You can change the shape or perspective of an image by applying Geometric effects. For example, you can turn an image into a sphere or cylinder, skew it, or change its vertical or horizontal perspective.

### Circle

Edit workspace

The Circle effect deforms your image or selection by turning it into a sphere. You can access the Circle dialog box by choosing **Effects ▶ Geometric Effects ▶ Circle**.

The Circle dialog box contains the following controls:

- **Wrap** — treats the image as though it were a tile repeating in each direction
- **Repeat** — finds the edge pixel of each side and repeats it outward infinitely
- **Color** — lets you choose a color to represent out-of-bounds pixels. You can click the color box to access the Color dialog box, or right-click the color box to access the Recent Colors dialog box.
- **Transparent** — makes out-of-bounds pixels transparent (available only with layered images)

### Cylinder–Horizontal

Edit workspace

The Cylinder–Horizontal effect stretches the image or selection as though wrapping it around a horizontal cylinder. You can access the Cylinder–Horizontal dialog box by choosing **Effects ▶ Geometric Effects ▶ Cylinder–Horizontal**.

The Cylinder–Horizontal dialog box has the following control:

- **Strength** — determines how much of the image appears wrapped

## Cylinder–Vertical

Edit workspace

The Cylinder–Vertical effect is a deformation that stretches the image or selection as though wrapping it around a vertical cylinder. You can access the Cylinder–Vertical dialog box by choosing **Effects ▶ Geometric Effects ▶ Cylinder–Vertical**.

The Cylinder–Vertical dialog box has the following control:

- **Strength** — determines how much of the image appears wrapped

## Pentagon

Edit workspace

The Pentagon effect deforms your image or selection by turning it into a pentagon. You can access the Pentagon dialog box by choosing **Effects ▶ Geometric Effects ▶ Pentagon**.

The Pentagon dialog box contains the following controls:

- **Wrap** — treats the image as though it were a tile repeating in each direction
- **Repeat** — finds the edge pixel of each side and repeats it outward infinitely
- **Color** — lets you choose a color to represent out-of-bounds pixels. You can click the color box to access the Color dialog box, or right-click the color box to access the Recent Colors dialog box.
- **Transparent** — makes out-of-bounds pixels transparent (available only with layered images)

## Perspective–Horizontal

Edit workspace

The Perspective–Horizontal effect creates a perspective along the horizontal axis by narrowing the left or right side of the image or selection. You can access the Perspective–Horizontal dialog box by choosing **Effects ▶ Geometric Effects ▶ Perspective–Horizontal**.

The Perspective–Horizontal dialog box contains the following controls:

- **Distortion** — sets the length of the shortened edge to the unchanged edge. Moving the slider to the left or typing a negative number reduces the length of the left side of the image. Moving the slider to the right or typing a positive number reduces the length of the right side of the image.
- **Wrap** — treats the image as though it were a tile repeating in each direction
- **Repeat** — finds the edge pixel of each side and repeats it outward infinitely
- **Color** — lets you choose a color to represent out-of-bounds pixels. You can click the color box to access the Color dialog box, or right-click the color box to access the Recent Colors dialog box.
- **Transparent** — makes out-of-bounds pixels transparent (available only with layered images)

## Perspective–Vertical

Edit workspace

The Perspective–Vertical effect creates a perspective along the vertical axis by narrowing the top or bottom of the image or selection. You can access the Perspective–Vertical dialog box by **Effects ▶ Geometric Effects ▶ Perspective–Vertical**.

The Perspective–Vertical dialog box contains the following controls:



- **Distortion** — sets the length of the shortened edge to the unchanged edge. Moving the slider to the left or typing a negative number reduces the length of the upper side of the image. Moving the slider to the right or typing a positive number reduces the length of the bottom side of the image.
- **Wrap** — treats the image as though it were a tile repeating in each direction
- **Repeat** — finds the edge pixel of each side and repeats it outward infinitely
- **Color** — lets you choose a color to represent out-of-bounds pixels. You can click the color box to access the Color dialog box, or right-click the color box to access the Recent Colors dialog box.
- **Transparent** — makes out-of-bounds pixels transparent (available only with layered images)

## Skew

Edit workspace

The Skew effect tilts an image or selection along its horizontal or vertical axis up to 45 degrees in either direction. You can access the Skew dialog box by choosing **Effects ▶ Geometric Effects ▶ Skew**.

The Skew dialog box contains the following controls:

- **Horizontal** — tilts the image to the left or right, depending on the Skew Angle setting
- **Vertical** — tilts the image up or down, depending on the Skew Angle setting
- **Skew angle** — sets the tilt angle. When the Horizontal option is selected, positive numbers tilt the image to the right, and negative numbers tilt it to the left. When the Vertical option is selected, positive numbers lower the left side and raise the right side, and negative numbers raise the left side and lower the right side.

- **Wrap** — treats the image as though it were a tile repeating in each direction
- **Repeat** — finds the edge pixel of each side and repeats it outward infinitely
- **Color** — lets you choose a color to represent out-of-bounds pixels. You can click the color box to access the Color dialog box, or right-click the color box to access the Recent Colors dialog box.
- **Transparent** — makes out-of-bounds pixels transparent (available only with layered images)

## Spherize

Edit workspace

The Spherize effect wraps a selection or layer around a sphere. You can access the Spherize dialog box by choosing **Effects ▶ Geometric Effects ▶ Spherize**.

The Spherize dialog box contains the following controls:

- **Strength** — determines the strength of the effect
- **Circle** — wraps the selection or layer around a circular sphere
- **Ellipse** — wraps the selection or layer around an elliptical sphere

## Applying Illumination effects

You can use an Illumination effect to apply a sunburst or spotlights to images.

***Important!** These effects work on grayscale and 16 million-color (24-bit) images only. For more information about increasing the color depth of an image, see “Increasing the color depth of an image” on page 632.*

## Lights

Edit workspace

The Lights effect uses up to five spotlights to apply lighting to an image. You can set the intensity, direction, color, and origin of the light source. You can access the Lights dialog box by choosing **Effects ▶ Illumination Effects ▶ Lights**.

The Lights dialog box contains the following controls:

- **Darkness** — determines the darkness of the non-illuminated areas of the image
- **Light source** buttons — lets you choose the spotlights you want to apply. You can also click the light dots on the image in the Before pane.
- **On** — lets you turn individual spotlights on or off. To turn a spotlight off, you can click the light source button (or the spotlight in the Before pane) and then unmark the On check box.
- **Color** — lets you choose a color for the spotlight. You can click the color box to access the Color dialog box, or right-click the color box to access the Recent Colors dialog box.
- **Intensity** — sets the brightness of the spotlight
- **Direction** — sets the lighting direction. The needle points to the direction of the light source, measured in degrees of rotation around the circle. To set the value, you can drag the needle, click in the circle, set or type a number in the control, or click the spotlight in the Before pane and drag its center arm.
- **Horizontal** — positions the light source horizontally. For each light, a value of 0 indicates the center of the image. Positive values produce movement to the right, and negative values produce movement to the left.

- **Vertical** — positions the light source vertically. For each light, a value of 0 indicates the center of the image. Positive values produce upward movement, and negative values produce downward movement.
- **Scale** — controls the size of the image area that is covered by light
- **Smoothness** — determines the smoothness of the transition from the light area to the dark area at the edge of the cone. At lower settings, the edge is sharp. Increasing the value produces a more gradual transition.
- **Cone size** — sets the width of the light, or cone size. As you increase the size to 89, the cone widens. You can also alter the width by dragging either handle of the light source in the Before pane.
- **Asymmetry** — lengthens or shortens the asymmetry

## Sunburst

Edit workspace

The Sunburst effect simulates the appearance of an image and light source viewed through a camera lens. You can adjust the light origin, the amount of radiating light, and the brightness of the halos, or glare spots. You can access the Sunburst dialog box by choosing **Effects ▶ Illumination Effects ▶ Sunburst**.

The Sunburst dialog box contains the following controls:

- **Color** — lets you choose a color for the effect. You can click the color box to access the Color dialog box, or right-click the color box to access the Recent Colors dialog box.
- **Brightness** in the **Light spot** group box — controls the strength of the light source
- **Horizontal** — indicates the horizontal location of the light origin. A value of 0 corresponds to the far left side of the image, and a

value of 100 corresponds to the far right side of the image. You can also set this value by dragging the crosshairs in the Before pane.

- **Vertical** — indicates the vertical location of the light origin. You can also set this value by dragging the crosshairs in the Before pane.
- **Density** — determines how many rays of light radiate from the light source
- **Brightness** in the **Rays** group box — controls the lightness of the light rays
- **Brightness** in the **Circles** group box — controls the visibility of the halos, or glare spots

## Applying Image effects

You can apply an Image effect to your image. This group of effects lets you offset an image, curl the corners of an image, or tile an image.

### Offset

Edit workspace

The Offset effect shifts the image on the canvas so that pixels are wrapped around to the opposite edge as they move off the canvas. You can access the Offset dialog box by choosing **Effects ▶ Image Effects ▶ Offset**.

The Offset dialog box has the following controls:

- **Horizontal offset** — lets you move the image horizontally on the page when the Custom option is selected
- **Vertical offset** — lets you move the image vertically on the page when the Custom option is selected

- **Center** — positions the image so that one corner is exactly in the middle of the page
- **Custom** — lets you adjust the position of the image horizontally and vertically on the page
- **Wrap** — treats the image as if it were a tile repeating in each direction
- **Repeat** — finds the edge pixel of each side and repeats it outward infinitely
- **Color** — lets you choose a color to represent out-of-bounds pixels. You can click the color box to access the Color dialog box, or right-click the color box to access the Recent Colors dialog box.
- **Transparent** — makes out-of-bounds pixels transparent (available only with layered images).

## Page Curl

Edit workspace

The Page Curl effect makes the image appear as though a corner of it has been rolled up. You can access the Page Curl dialog box by choosing **Effects ▶ Image Effects ▶ Page Curl**.

The Page Curl dialog box contains the following controls:

- **Color** in the **Curl settings** group box — lets you select a color for the curled-back corner of the image page. You can click the color box to access the Color dialog box, or right-click the color box to access the Recent Colors dialog box.
- **Radius** — determines the amount of the curl. As you increase the value, the curl loosens.
- **Corner** buttons — let you select which corners to curl
- **Width** — determines the width of the curl. You can also specify the desired width by dragging the arm in the Before pane.

- **Height** — determines the height of the curl. You can also specify the desired height by dragging the arm in the Before pane.
- **Color** in the **Edge mode** group box — lets you select a color for the background underneath the curled area of the page. You can click the color box to access the Color dialog box, or right-click the color box to access the Recent Colors dialog box.
- **Transparent** — makes out-of-bounds pixels transparent (available only with layered images)

## Seamless Tiling

Edit workspace

The Seamless Tiling effect helps you convert a selection into a seamless custom pattern, which you can use for painting, adding text, or creating Web page backgrounds. You can access the Seamless Tiling dialog box by choosing **Effects ▶ Image Effects ▶ Seamless Tiling**.

The Seamless Tiling dialog box contains the following controls:

- **Show tiling preview** — opens a preview area that displays the tile you are designing
- **Edge** — blends the edges of the image
- **Corner** — blends the image at the corners
- **Mirror** — mirrors the edges of the image
- **Horizontal** — places the tiles horizontally on the image
- **Vertical** — places the tiles vertically on the image
- **Bidirectional** — places the tiles both horizontally and vertically on the image. If you choose **Bidirectional**, you must choose a setting from the **Corner style** group box.
- **Horizontal offset** — positions the center of the tiling effect horizontally in the image. The position is a percentage of the width of the image. At 50, the tiling starts at the center of the

image. You can increase the value to move the center to the right and decrease the value to move the center to the left.

- **Vertical offset** — positions the center of the tiling effect vertically in the image. The position is a percentage of the height of the image. At 50, the tiling starts at the center of the image. You can increase the value to move the center toward the bottom and decrease the value to move the center toward the top.
- **Width** — sets the width of the tile
- **Transition** — lets you determine the degree of blending when the Edge option is selected
- **Linear** — lets you choose a linear corner when the Corner option is selected
- **Curved** — lets you choose a curved corner when the Corner option is selected

## Applying Photo effects

You can apply different Photo effects to your images to simulate some traditional photo techniques and processes.

### Time Machine

The Time Machine lets you recreate some popular photographic styles from the past. It lets you choose from seven styles, which range from the year 1839 to the 1980s. For information about the Time Machine, see “Creating vintage-style photos with the Time Machine” on page 487.

### Film and Filters

Corel PaintShop Pro lets you experiment with effects that are inspired by different types of camera film and filters. For information about



applying film and filter effects, see “Applying film and filter effects to photos” on page 491.

## Black and White Film

You can simulate taking a photo with black-and-white film. To modify the effect, you can apply a wide range of RGB values as well as adjust image brightness and clarity.

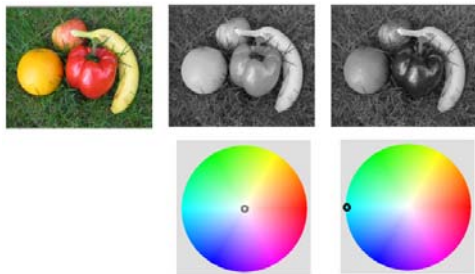

*Filter color adjustments in the Black and White Film dialog box can create very different results from the original photo (left-most image in top row).*

## Infrared Film

You can simulate the look created when you take a photo with black-and-white infrared film and an infrared pass lens filter on the camera. To enhance the effect, you can adjust settings for film grain and flare.



*Original photo (left) and the same photo with the Infrared Film effect applied (right)*

## **Sepia Toning**

You can simulate the look created when you take a photo with sepia film. Sepia-toned images are similar to black-and-white photos (also known as grayscale photos), except the tones are brown instead of gray.

## **Selective Focus**

You can create a quick miniature effect (also known as a tilt-shift effect) so that the scene in a photo resembles a miniature model or toy. The illusion is created by adjusting the depth of field, usually across a specified horizon line, and increasing the saturation of the photo.



*An urban scene (left) appears to be transformed into a miniature model (right).*

You can also use Selective Focus to apply a quick depth of field effect to any photo. For general information about depth of field, see “Controlling depth of field” on page 211.

**Photo tip:** Photos taken from high vantage points usually make the best candidates for a miniature effect.

## Vignette

You can fade the edges of a photo to create a vignette effect. You can control the appearance of the edges by choosing a shape and color (light or dark), and adjusting the amount of blur, glow, and feathering.



## Retro Lab

Inspired by photos taken spontaneously with a vintage-style pocket camera, such as LOMO, Diana, or Holga, the Retro Lab lets you apply a fun retro effect. For more information, see “Using Retro Lab” on page 484.

## Graduated Filter

You can apply a color gradient to your photos to simulate the effect achieved by using a graduated filter on your camera lens. For more information, see “Applying a gradient with the Graduated Filter effect” on page 486.

## To apply the Black and White Film effect

Edit workspace

- 1 Choose **Effects** ▶ **Photo Effects** ▶ **Black and White Film**.

The Black and White Film dialog box appears.

- 2 Modify the settings you want and click **OK**.

## You can also

---

Adjust the RGB filter color	In the <b>Filter Color</b> group box, click or drag inside the color spectrum to set the RGB filter color.  The <b>Red</b> , <b>Green</b> , and <b>Blue</b> values and the <b>After</b> pane are updated.
Simulate shooting the photo without a filter	In the <b>Filter Color</b> group box, place the filter toward the middle of the color spectrum, or click the <b>Reset to Default</b> button  below the <b>After</b> pane.
Use an automatic filter setting	In the <b>Filter Color</b> group box, click <b>Suggest Color</b> .
Adjust overall brightness	In the Adjustments group box, drag the <b>Brightness</b> slider, or type or set a value in the control.
Adjust overall clarity	In the Adjustments group box, drag the <b>Clarity</b> slider, or type or set a value in the control.

---

## To apply the Infrared Film effect

Edit workspace

- 1 Choose **Effects** ▶ **Photo Effects** ▶ **Infrared Film**.

The Infrared Film dialog box appears.

- 2 Type or set a value in the **Strength** control to determine the overall strength of the Infrared effect.

Higher settings make greens appear brighter and blues appear darker. Setting the value to 0 creates a grayscale image.

- 3 Type or set a value in the **Flare** control to apply a halo effect to lighter areas in the photo.

Higher settings intensify the halation effect, producing soft edges throughout the photo. Lower settings minimize the halation effect.

- 4 Type or set a value greater than 0 in the **Grain** control to add a more realistic infrared graininess to the photo.
- 5 Click **OK**.

## To apply the Sepia Toning effect

Edit workspace

- 1 Choose **Effects ▶ Photo Effects ▶ Sepia Toning**.

The Sepia Toning dialog box appears.

- 2 Type or set a value in the **Amount to age** control to determine the strength of the effect.



Higher settings increase the effect by increasing the amount of brown in the image.

## To apply a miniature effect by using Selective Focus

Edit workspace

- 1 Choose **Effects ▶ Photo Effects ▶ Selective Focus**.

The Selective Focus dialog box appears. You can maximize the dialog box to increase the size of the Before and After panes of the preview area.

- 2 In the Area of focus, click one of the following tools:
  - **Planar Selection Tool**  — the default tool for setting a linear area of focus. It is effective at setting an area of focus along a road, bridge, or other linear element that isn't along the edge of your photo.
  - **Half Planar Selection Tool**  — lets you set a linear area of focus along the edge of a photo
  - **Radial Selection Tool**  — lets you set a circular area of focus

- 3 In the Before pane of the preview area, when your pointer displays the move cursor , drag the area of focus to the position you want.
- 4 Drag the rotation handle (the box at the end of the short line) to rotate the area of focus.
- 5 Drag a sizing handle (on the solid lines) to set the edges for the area of focus.
- 6 Fine-tune the results by dragging any of the following sliders:
  - **Blur amount** — determines the amount of blur outside the area of focus
  - **Feather edge** — determines the softness of the transition between the area in focus and the blurred areas. You can also adjust feathering interactively by dragging a feathering handle (on the dotted lines) in the Before pane.
  - **Saturation** — determines the intensity of the colors in the photo. Increasing saturation can help simulate the vivid paint colors used for models and toys.

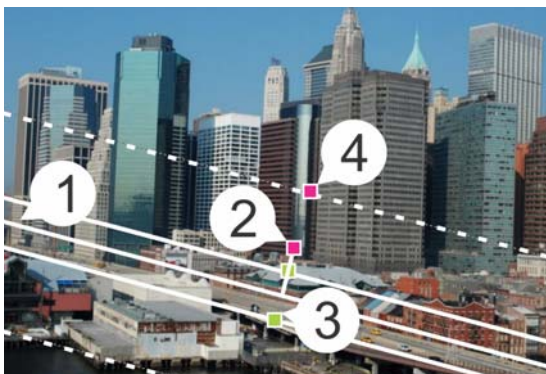

*Interactive elements in the Before pane: (1) Center line (for Planar Selection Tool), (2) Rotation handle, (3) Sizing handle, (4) Feathering handle*



You can use the Selective Focus effect to apply a quick depth of field effect. Adjust the settings to achieve a natural look.

## To apply a Vignette effect

Edit workspace

- 1 Click **Effects** ▶ **Photo Effects** ▶ **Vignette**.
- 2 In the Area of focus, choose a selection tool and drag in the Before pane to set the edge for the effect.
- 3 Drag the **Dark/Light** slider to set an edge color.
- 4 Fine-tune the results by dragging any of the following sliders:
  - **Blur** — determines the amount of blur outside the area of focus
  - **Diffuse glow** — adds a luminescent brightening effect and softens details in the entire photo
  - **Feather edge** — determines the softness of the transition between the area in focus and the edge effect

## Using Retro Lab

Inspired by photos taken spontaneously with a vintage-style pocket camera, such as LOMO, Diana, or Holga, the Retro Lab lets you apply a fun retro effect. Sometimes referred to as a “toy camera” effect, this photo style is often characterized by colors and contrast that are pushed beyond their natural appearance with blurred or vignette edges.

For a quick effect, apply a preset. Want to dig deep? You can access a complete set of controls that let you create and save your own presets.





*Original photo (left); photo after using Retro Lab (right). The Surreal preset was applied, then the Range controls and the Saturation slider were used to customize the effect.*

## To use Retro Lab to create a toy camera effect

### 1 Click **Effects** ▶ **Photo Effects** ▶ **Retro Lab**.

If you want to apply a preset, click a preset in the Settings drop-list. Click **OK** to apply and exit the dialog box, or continue to the next step to create a custom effect.

### 2 To create a custom effect, do any of the following:

- In the Range area, click an **Area of focus** tool and drag in the **Before** pane of the Preview area to select an area of focus.
- Adjust the settings in the Range area to adjust the vignette effect. For information about individual controls, see “To apply a Vignette effect” on page 484.
- In the Color Adjust area, drag the sliders to get the color effect you want.

- In the Curves area, click and drag the diagonal line to adjust the tone or choose a color from the **Channel** drop-list and drag the diagonal line to adjust individual color channels. For more information about Curves, see “To change color channel brightness” on page 189.

If you want to save your settings, click the **Save Preset** button , type a name in the **Preset name** box, and click **OK**.

## Applying a gradient with the Graduated Filter effect

You can apply a color gradient to your photos to simulate the effect achieved by using a graduated filter on your camera lens. Graduated filters often consist of a single color that fades to transparent. This lets you adjust the color in a specific area of the photo. For example, in a photo where you want an otherwise too bright sky to have more blue, you can use a blue graduated filter to increase the blue of the sky without affecting the lower part of the photo. If you want to push your creativity, the Graduated Filter effect lets you choose from different gradient shapes and dual-color options.



*The Graduated Filter effect was applied to the original photo (left) to create a sunset effect and to intensify the blue of the water.*

### To apply a gradient with the Graduated Filter effect

- 1 Click **Effects** ▶ **Photo Effects** ▶ **Graduated Filter**.

The Graduated Filter dialog box appears.

- 2 Click a **Style** button to determine the shape of the gradient.

The default option, **Linear Graduated Filter**, best simulates traditional graduated filters.

- 3 Drag in the Before pane to set the size and direction of the gradient. A line displays as you drag.
- 4 In the Preset drop-list, choose a type of blend.
- 5 In the Color area, click a color swatch to set a color.

If you want to change the direction of the color or transparency, click the **Swap Colors** button .

- 6 In the Settings area, adjust any of the following sliders:
  - **Opacity** — specifies the transparency of the colors. Lower values are more transparent.
  - **Blend** — specifies how gradual the color transition is. Higher values produce a softer blend.
  - **Rotate** — specifies the angle of the gradient in degrees.



If you want to fine-tune specific areas of your photo, you can paste your finished version as a layer over the original version. You can then use the Eraser tool to reveal original colors and detail.

## Creating vintage-style photos with the Time Machine

The Time Machine lets you recreate some vintage photographic styles. It lets you choose from seven styles, which range from the year 1839 to the 1980s.

The table below describes each style.



**Daguerreotype** — Widely used from 1839 to 1855, the daguerreotype was the first popular form of photography. Images were captured directly on a thin piece of silver-plated copper. Because no negative was produced, copies could not be made, so each image was unique. Daguerreotypes are often characterized by their reflective quality, a darkening at the edges, and a dark blue-gray or brown-black color.

---



**Albumen** — Widely used from 1855 to the 1890s, this inexpensive photographic method produced paper-based photos. Negatives were captured on glass, and the print was then created on paper that used albumen from egg whites to bind the light-sensitive chemicals to the paper. Albumen photos are often characterized by their glossy finish, and soft, warm, brown tones.

---



**Cyanotype** — Invented in 1841, this simple, inexpensive photographic method became popular from the late 19th century to the early 20th century. The images are created when ultraviolet light converts the light-sensitive chemicals on the paper to Prussian blue. Cyanotypes are characterized by their brilliant blue color. Although this process did not lend itself to portrait photography, the permanence of the images made them popular for scientific and engineering purposes. For example, this method was used for creating blueprints.

---



**Platinum** — Popular from 1873 to 1920, this photographic method used platinum-based developing materials and placed the paper in direct contact with the negative. Although the resulting high-quality prints remained stable over time, the high price of platinum made this method expensive. Platinum prints are often characterized by their wide tonal range and silvery-black colors. This method was revived by artists in the 1960s.



**Early Color** — Autochrome was a popular method of producing early color photographs. This method was developed by the Lumière brothers (Auguste and Louis Lumière) in 1904. It used potato starch granules, dyed red, green, and blue, to create colored images on glass, similar to a slide. Autochromes are often characterized by softer colors and a slightly grainy quality.



**Box camera** — The box camera was popular from 1900 to the 1960s. The simplicity and portability of the camera meant that anyone could take photos. Photos taken with box cameras have different characteristics, which reflect the age of the camera, the type of film, and the skill of the photographer.



**Cross Process** — Cross-processing is a modern photography technique that creates unique color effects by mismatching the film and the chemicals used to develop the film. For example, you can achieve this effect by processing slide film in chemicals designed for color negative film. Cross-processed photos are often characterized by skewed colors, high saturation, and extreme highlights.

## Time Machine settings

The Time Machine dialog box includes thumbnails that let you preview each effect on your photo. It also contains an information box that gives you a brief description of the effect.



*The photo on the left is the original photo, and the photo on the right has the Time Machine's Daguerreotype style applied to it.*

You can adjust each effect by using the Intensity slider in the Time Machine dialog box. The Intensity slider changes the appearance of the effect in different ways, depending on the effect you choose. For example, the Intensity slider may adjust the color, brightness, or contrast.

You can apply edges to your photos that simulate the look of the edge of the paper on vintage-style photos. For example, the Photo Edges feature can simulate the dark edges of daguerreotypes, the uneven blue edges of cyanotypes, and the decorative edges that were popular during the box camera era. Photo Edges are added to the outside edge of a photo.

You can also apply edge and frame effects by using the Picture Frame dialog box. For more information, see “Adding picture frames to images” on page 514.

## To create vintage-style photos with the Time Machine

Edit workspace

- 1 Choose **Effects** ▶ **Photo Effects** ▶ **Time Machine**.
- 2 Click one of the thumbnails above the timeline to choose an effect.
- 3 Move the **Intensity** slider to adjust the appearance of the effect.



You can add or remove edge effects for photos. Unmark the **Photo Edges** check box below the Intensity slider to remove the edges, or mark the check box to apply the edges.

## Applying film and filter effects to photos

Whether you are a novice or an experienced photographer, you can experiment in Corel PaintShop Pro with effects that are inspired by different types of camera film and filters. You can choose from a list of preset film effects, called Film Looks, or you can choose from a list of preset filter effects, called Creative Filters. You can also combine a film effect with a filter effect to create a unique style.

### Film Looks

Film Looks are inspired by the effects achieved when you use different types of film in a traditional camera. Film Looks are described by the type of effect they achieve, rather than a film name, which makes them easier to identify. You can experiment with them even if you've never worked with different types of film. Unlike the Creative Filters, which apply a color to the entire photo, Film Looks can change what is emphasized in a photo by making some colors more dramatic or more subtle. Some Film Looks also change the contrast or softness of photos.



*The Vibrant Foliage Film Look enhances blues and greens.*

The following Film Looks are available:

Film Look	Purpose	Description
Vivid	General purpose	Increases the saturation and contrast in a photo to make the colors more vivid
Vivid skin tones	Portraits	Enhances skin tones
Muted reds	General purpose, changes emphasis	Makes reds more subtle
Enhanced reds	General purpose, changes emphasis	Emphasizes reds
Vibrant foliage	Landscapes	Enhances blues and greens
Warm earth tones	Landscapes	Enhances reds, oranges, and yellows
Glamour	Portraits	Creates a soft glow

You can also apply the following film effects:

- Black-and-white — For more information, see “To apply the Black and White Film effect” on page 480.
- Sepia toning — For more information, see “To apply the Sepia Toning effect” on page 482.



- Infrared — For more information, see “To apply the Infrared Film effect” on page 481.

## Creative Filters

Creative Filters simulate the effect achieved when you use color filters on the lens of your camera. Although the color is applied across the entire photo, Corel PaintShop Pro maintains the luminance of the image, to achieve a color toning effect. You can use a preset color or choose a custom color.

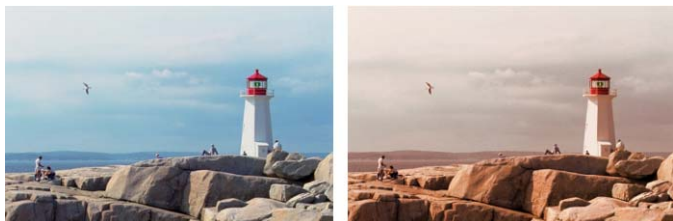

*The Sunset filter adds a warm orange tone to your photos.*

The following Creative Filters are available:

Creative Filter	Description
Night effect	Applies a dark blue filter to make a photo look like it was taken at dusk or in moonlight
Cooling	Cools image colors
Warming	Applies a subtle warming effect
Orange	Warms colors to intensify photos with fall colors or other warm tones
Champagne	Applies a subtle warming effect that works well with portraits, especially when combined with the Glamour Film Look.

Creative Filter	Description
Sunset	Simulates the orange-red lighting conditions that occur at sunset
Custom	Lets you choose a filter color

## To apply film and filter effects to a photo

Edit workspace

- 1 Choose **Effects** ▶ **Photo Effects** ▶ **Film and Filters**.
- 2 In the Film and Filters dialog box, perform one or more tasks from the following table, and click **OK**.

To	Do the following
Apply a Film Look	Choose a style from the <b>Film looks</b> drop-list.
Apply a filter	Choose a filter from the <b>Creative filters</b> drop-list.
Choose a custom filter color	Click the <b>Filter color</b> swatch, and choose a color from the Color dialog box.
Change the amount of color applied by a filter	Type a value in the <b>Density</b> box. Higher numbers increase the amount of color; lower numbers decrease the amount of color.

## Applying Reflection effects

The reflection effects include such effects as a kaleidoscope or an intricate pattern.

### Feedback

Edit workspace

The Feedback effect makes the image appear reflected in concentric squares or circles. You can access the Feedback dialog box by choosing **Effects** ▶ **Reflection Effects** ▶ **Feedback**.

The Feedback dialog box contains the following controls:

- **Opacity** — controls the strength of the effect. As the Opacity increases, the image displays more of the effect and less of its original appearance.
- **Intensity** — sets the number of image repetitions
- **Horizontal offset** — positions the center of the feedback effect horizontally in the image. The position is a percentage of the width of the image. At 50, the feedback effect starts at the center of the image. Increasing the value moves the center to the right. Decreasing the value moves the center to the left.
- **Vertical offset** — positions the center of the feedback effect vertically in the image. The position is a percentage of the height of the image. At 50, the feedback effect starts at the center of the image. Increasing the value moves the center toward the bottom. Decreasing the value moves the center toward the top.
- **Elliptical** — makes the feedback elliptical (oval). You can unmark the check box to return to the rectangular (default) shape of the feedback.

## Kaleidoscope

Edit workspace

The Kaleidoscope effect turns a pie-shaped area of an image or selection into a circular pattern. The result is similar to the pattern seen in a kaleidoscope. You can access the Kaleidoscope dialog box by choosing **Effects ▶ Reflection Effects ▶ Kaleidoscope**.

The Kaleidoscope dialog box contains the following controls:

- **Horizontal offset** — determines the horizontal origin of the effect. Negative values move the pie origin to the left. Positive values move the pie origin to the right. The values are a percentage of the width of the range.

- **Vertical offset** — determines the vertical origin of the effect. Negative values move the pie origin up. Positive values move the pie origin down. The values are a percentage of the height of the image.
- **Rotation angle** — affects which edges appear light and shadowed. The needle points to the direction of the light source, measured in degrees of rotation around the circle.
- **Scale factor** — controls how much of the pie-shaped area is enlarged or reduced when you create the kaleidoscope pattern. As you decrease the scale, the pattern repeats itself more frequently.
- **Number of petals** — determines the repetitions of the pattern. The number of repetitions controls the width of the pie. When you enter a lower value, the arc is repeated fewer times.
- **Number of orbits** — sets the number of times the circles of the pattern repeat
- **Radial suction** — controls where in the pie the image information is used to create the pattern. As you increase the value, this area is pushed toward the outer edge of the pie.
- **Wrap** — treats the image as though it were a tile repeating in each direction
- **Repeat** — finds the edge pixel of each side and repeats it outward infinitely
- **Color** — lets you choose a color to represent out-of-bounds pixels. You can click the color box to access the Color dialog box, or right-click the color box to access the Recent Colors dialog box.
- **Reflect** — reflects the edge pixel on each side

## Pattern

Edit workspace

The Pattern effect turns any image or selection into an intricate geometric pattern. You can use these patterns to create seamless tiles for the background of your Web page. You can access the Pattern dialog box by choosing **Effects ▶ Reflection Effects ▶ Pattern**.

The Pattern dialog box contains the following controls:

- **Horizontal offset** — determines the horizontal origin of the effect. Negative values move the origin to the left. Positive values move the origin to the right. The values are a percentage of the width of the range.
- **Vertical offset** — determines the vertical origin of the effect. Negative values move the origin up. Positive values move the origin down. The values are a percentage of the height of the image.
- **Rotation angle** — affects which edges appear light and shadowed. The needle points to the direction of the light source, measured in degrees of rotation around the circle.
- **Scale factor** — controls the size of the pattern. The default of 0 uses the original scale of the image. As you decrease the scale, the pattern repeats itself more frequently.
- **Number of columns** — sets the number of times the pattern is repeated from the left side to the right side of the image at a scale factor of 0
- **Number of rows** — sets the number of times the pattern is repeated from the top to the bottom of the image at a scale factor of 0
- **Horizontal shift** — moves the pattern with the image window. You can place a specific section of the pattern at the center. You can

use this box along with the Scale factor box to create a seamless pattern.

- **Vertical shift** — moves the pattern with the image window. You can place a specific section of the pattern at the center. You can use this box along with the Scale factor box to create a seamless pattern.

## Rotating Mirror

[Edit workspace](#)

The Rotating Mirror effect reflects an image or selection along a radial angle. You can access the Rotating Mirror dialog box by choosing **Effects ▶ Reflection Effects ▶ Rotating Mirror**.

The Rotating Mirror dialog box contains the following controls:

- **Horizontal offset** — moves the center point of the reflection line away from the image center. The value is a percentage of the width of the image. Negative horizontal values move the reflection line to the left, while positive values move it to the right. The horizontal offset does not affect horizontal lines.
- **Vertical offset** — moves the center point of the reflection line away from the image center. The value is a percentage of the height of the image. Negative values raise the reflection line, and positive values lower it. The vertical offset does not affect vertical lines.
- **Rotation angle** — sets the angle of the rotation line. The angle corresponds to the degrees of a circle, so entering 0 and 180 creates reflection along a vertical line. Entering 90 and 270 creates reflection along a horizontal line. You can create diagonal lines between the corners by entering 45, 135, 225, and 315.
- **Wrap** — treats the image as though it were a tile repeating in each direction

- **Repeat** — finds the edge pixel of each side and repeats it outward infinitely
- **Color** — lets you choose a color to represent out-of-bounds pixels. You can click the color box to access the Color dialog box, or right-click the color box to access the Recent Colors dialog box.
- **Reflect** — reflects the edge pixel on each side

## Applying Texture effects

You can apply the Texture effects to your images. These effects make the surfaces of your images resemble those of various materials, such as leather, mosaic tiles, and polished stone.

### Blinds

Edit workspace

The Blinds effect makes the image appear to be drawn on vertical or horizontal window blinds. You can access the Blinds dialog box by choosing **Effects ▶ Texture Effects ▶ Blinds**.



The Blinds dialog box contains the following controls:

- **Width** — sets the width of the blinds
- **Opacity** — controls the strength of the effect. As the Opacity increases, the image displays more of the effect and less of its original appearance.

- **Color** — lets you choose a color other than the default of black. You can click the color box to access the Color dialog box, or right-click the color box to access the Recent Colors dialog box.
- **Horizontal** — makes the blinds horizontal. You can unmark the check box to return the blinds to the default, vertical orientation.
- **Light from left/top** — lets you reverse the direction of light from the default setting, which is from the right side for a vertical orientation or the bottom for a horizontal orientation. The hard edge of the blinds is opposite to the light direction.

## Emboss

[Edit workspace](#)

The Emboss effect converts the image into a bas-relief. The effect highlights the areas of contrast with black or white pixels, and it colors the low-contrast areas a medium gray. Color appears in areas of higher contrast. You can apply the Emboss effect by choosing **Effects ▶ Texture Effects ▶ Emboss**.



## Fine Leather

[Edit workspace](#)

The Fine Leather effect makes the image appear embossed on fine-grained leather. You can access the Fine Leather dialog box by choosing **Effects ▶ Texture Effects ▶ Fine Leather**.





The Fine Leather dialog box contains the following controls:

- **Color** — lets you choose a color for the light shining on the image. To change the light color, you can click a color in the original image, click the color box to access the Color dialog box, or right-click the color box to access the Recent Colors dialog box.
- **Angle** — affects which edges appear light and shadowed. The needle points to the direction of the light source, measured in degrees of rotation around the circle. To set the value, you can click in the circle, drag the needle, or set or type a number in the control.
- **Blur** — determines the softness of the image. As you increase the value, the image becomes less sharp.
- **Transparency** — controls how much of the original image is visible. As you increase the value, more of the image shows through the furrows.
- **Number of furrows** — controls how many leather furrows, or lines, are applied
- **Length of furrows** — controls the length of the furrows, or lines

## Fur

Edit workspace

The Fur effect gives the image the appearance of being covered in fur or bristles. You can access the Fur dialog box by choosing **Effects ▶ Texture Effects ▶ Fur**.



The Fur dialog box contains the following controls:

- **Blur** — determines the softness of the image. As you increase the value, the image becomes less sharp.
- **Density** — controls the strength of the effect. Increasing the value adds more fur to the image.
- **Length** — sets the length of the individual strands of fur
- **Transparency** — controls how much of the image is visible. As you increase the value, the fur effect becomes more transparent, letting more of the image show through.

## Mosaic–Antique

[Edit workspace](#)

The Mosaic–Antique effect makes an image appear to be created from antique tiles. You can access the Mosaic–Antique dialog box by choosing **Effects ▶ Texture Effects ▶ Mosaic–Antique**.



The Mosaic–Antique dialog box contains the following controls:

- **Number of columns** — sets the number of columns of tiles. As you increase the number, you reduce the size of the tiles.
- **Number of rows** — sets the number of rows of tiles. As you increase the number, you reduce the size of the tiles.
- **Symmetric** — links the values for the numbers of rows and columns so that changing one value changes the other value. You can unmark this check box to have an unequal number of rows and columns.
- **Tile diffusion** — sets how much of the original image shows through the tiles. Increasing the opacity blurs the tiles.
- **Grout width** — sets the number of pixels between the tiles
- **Grout diffusion** — sets the opacity of the pixels between the tiles
- **Locked transparency fill color** — sets the fill color for the transparency

## Mosaic–Glass

Edit workspace

The Mosaic–Glass effect makes the image appear to be created from glass tiles. You can access the Mosaic–Glass dialog box by choosing **Effects ▶ Texture Effects ▶ Mosaic–Glass**.



The Mosaic–Glass dialog box contains the following controls:

- **Number of columns** — sets the number of columns of tiles. As you increase the number, the tiles become smaller.

- **Number of rows** — sets the number of rows of tiles. As you increase the number, the tiles become smaller.
- **Symmetric** — links the values for the numbers of rows and columns so that changing one value changes the other value. You can unmark this check box to have an unequal number of rows and columns.
- **Glass curvature** — sets the distortion of the tiles and the width and opacity of the area between them. As you increase the value, each tile displays a larger area of the image. The effect is similar to that produced by using the zoom-out setting of a camera lens.
- **Edge curvature** — sets the distortion of the area around the edges of the tiles. Larger values produce rounder edges and increase the zoom-out effect.
- **Grout width** — sets the number of pixels between the tiles
- **Grout diffusion** — sets the opacity of the pixels between the tiles
- **Lock transparency fill color** — sets the fill color for the transparency

## Polished Stone

Edit workspace

The Polished Stone effect makes the image appear carved on a hard, shiny surface. You can access the Polished Stone dialog box by choosing **Effects ▶ Texture Effects ▶ Polished Stone**.



The Polished Stone dialog box contains the following controls:

- **Blur** — determines the softness of the image. As you increase the value, the image becomes less sharp.
- **Detail** — controls the scale of the relief. As you increase the value, smaller areas of contrast are shown in relief.
- **Polishing** — controls the size of the polished area. As you increase the value, the roughness decreases and the surface appears smoother.
- **Angle** — affects which edges appear light and shadowed. The needle points to the direction of the light source, measured in degrees of rotation around the circle.
- **Color** — lets you choose a color for the light shining on the edges of the forms. To change the light color, you can click a color in the original image, click the color box to access the Color dialog box, or right-click the color box to access the Recent Colors dialog box.

## Rough Leather

Edit workspace

The Rough Leather effect makes the image appear embossed on leather with a coarse grain. You can access the Rough Leather dialog box by choosing **Effects ▶ Texture Effects ▶ Rough Leather**.



The Rough Leather dialog box contains the following controls:

- **Light color** — lets you choose a color for the light shining on the leather surface. To change the light color, you can click a color in the original image, click the color box to access the Color dialog

box, or right-click the color box to access the Recent Colors dialog box.

- **Leather color** — lets you choose a color for the leather background. To change the leather color, you can click a color in the original image, click the color box to access the Color dialog box, or right-click the color box to access the Recent Colors dialog box.
- **Angle** — affects which edges appear light and shadowed. The needle points to the direction of the light source, measured in degrees of rotation around the circle.
- **Luminance** — adjusts the overall brightness of the image
- **Contrast** — controls the roughness of the leather and the colors
- **Sharpness** — controls the sharpness of the edges in the image
- **Blur** — determines the blur of the original image

## Sandstone

Edit workspace

The Sandstone effect makes the image appear as though it is carved from sandstone. You can access the Sandstone dialog box by choosing **Effects ▶ Texture Effects ▶ Sandstone**.



The Sandstone dialog box contains the following controls:

- **Blur** — determines the softness of the original image

- **Detail** — controls the scale of the relief. As you increase the setting, the smaller areas of the contrast are shown in relief.
- **Luminance** — adjusts the overall brightness of the image
- **Angle** — affects which edges appear light and shadowed. The needle points to the direction of the light source, measured in degrees of rotation around the circle.
- **Color** — lets you choose a color for the light shining on the edges of the forms. To change the light color, you can click a color in the original image, click the color box to access the Color dialog box, or right-click the color box to access the Recent Colors dialog box.

## Sculpture

Edit workspace

The Sculpture effect accentuates the edges of the image so that they appear embossed or sculpted and overlays the result with a colored pattern. The patterns are 24-bit RGB images stored in the Patterns folder. You can access the Sculpture dialog box by choosing **Effects ▶ Texture Effects ▶ Sculpture**.



The Sculpture dialog box contains the following controls:

- **Pattern** — lets you select the pattern. The image's color is the result of the pattern color combined with the light color.
- **Size** — resizes the pattern to a percentage of its original dimensions. You can decrease the value to make the pattern tiling more pronounced and increase the value to enlarge the pattern.

- **Smoothness** — controls the slope (sharpness) and thickness of the edges
- **Depth** — controls the height of the sculpting
- **Ambience** — adjusts the overall brightness of the image
- **Shininess** — determines how reflective the surface appears
- **Color** — lets you choose the color of the light shining on the image. The pattern color and saturation affect the light color. To change the light color, you can click a color in the original image, click the color box to access the Color dialog box, or right-click the color box to access the Recent Colors dialog box.
- **Angle** — affects which edges appear light and shadowed. The needle points to the direction of the light source, measured in degrees of rotation around the circle.
- **Intensity** — adjusts the brightness of the directional light. Note that the Ambience value determines the brightness of the entire image before the intensity is applied.
- **Elevation** — shows the angle of elevation of the light source above the image. At a setting of 90 degrees, the light source is positioned directly overhead. As you lower the value, the light source moves closer to the image, producing longer shadows.

## Soft Plastic

[Edit workspace](#)

The Soft Plastic effect makes the image look as though it were molded from plastic. You can access the Soft Plastic dialog box by choosing **Effects ▶ Texture Effects ▶ Soft Plastic**.





The Soft Plastic dialog box contains the following controls:

- **Blur** — determines the softness of the original image
- **Detail** — controls the scale of the relief
- **Density** — controls the number of areas of relief. Lower values produce fewer larger areas and a softer look. Higher values add relief to smaller areas, producing a denser effect.
- **Angle** — affects which edges appear light and shadowed. The needle points to the direction of the light source, measured in degrees of rotation around the circle.
- **Color** — lets you choose a color for the light shining on the edges of the forms. To change the light color, you can click a color in the original image, click the color box to access the Color dialog box, or right-click the color box to access the Recent Colors dialog box.

## Straw Wall

Edit workspace

The Straw Wall effect makes the image look like it is covered in straw. You can access the Straw Wall dialog box by choosing **Effects ▶ Texture Effects ▶ Straw Wall**.



The Straw Wall dialog box contains the following controls:

- **Blur** — determines the softness of the original image
- **Density** — controls the number of straws covering the image
- **Length** — determines the length of the straws
- **Width** — determines the width of the straws
- **Transparency** — controls how much of the image is visible
- **Color** — lets you choose a color for the light shining on the edges of the forms. To change the light color, you can click a color in the original image, click the color box to access the Color dialog box, or right-click the color box to access the Recent Colors dialog box.
- **Angle** — affects which edges appear light and shadowed. The needle points to the direction of the light source, measured in degrees of rotation around the circle.

## Texture

[Edit workspace](#)

The Texture effect makes the image appear three-dimensional, as though it had a textured surface. You create the textures by using seamless tiles of 8-bit grayscale images that are stored in the Textures folder. You can access the Texture dialog box by choosing **Effects ▶ Texture Effects ▶ Texture**.



The Texture dialog box contains the following controls:

- **Texture** swatch — lets you choose the texture
- **Size** — resizes the texture to a percentage of its original dimensions. You can decrease the scale to make the tiling more pronounced and increase the scale to enlarge the texture.
- **Smoothness** — controls the slope (sharpness) and thickness of the edges
- **Depth** — controls the height of the edges
- **Ambience** — adjusts the overall brightness of the image
- **Shininess** — determines how reflective the surface appears
- **Color** — lets you choose a color for the light shining on the image. To change the light color, you can click a color in the original image, click the color box to access the Color dialog box, or right-click the color box to access the Recent Colors dialog box.
- **Angle** — affects which edges appear light and shadowed. The needle points to the direction of the light source, measured in degrees of rotation around the circle.
- **Intensity** — adjusts the brightness of the directional light. Note that the Ambience value determines the brightness of the entire image before the Intensity effect is applied.
- **Elevation** — shows the angle of elevation of the light source above the image. At a setting of 90 degrees, the light source is

positioned directly overhead. As you lower the value, the light source moves closer to the image, producing longer shadows.

## Tiles

Edit workspace

The Tiles effect makes the image appear to be created from tiles. The tiles can be of varying shape, depth, and shininess. You can access the Tiles dialog box by choosing **Effects ▶ Texture Effects ▶ Tiles**.



The Tiles dialog box contains the following controls:

- **Tile Shape** — lets you select a triangular, square, or hexagonal tile
- **Tile Angularity** — reshapes the tiles. As you increase the value, the original tile shape changes to multiple shapes that align more closely with the edges of the image.
- **Tile Size** — lets you increase or decrease the size of the tiles
- **Border Size** — controls the grout, which is the width of the space between tiles. Note that the grout is always black.
- **Smoothness** — controls the slope (sharpness) and thickness of the edges
- **Depth** — controls the height of the edges
- **Ambience** — adjusts the overall brightness of the image
- **Shininess** — determines how reflective the surface appears
- **Color** — lets you choose a color for the light shining on the image. To change the light color, you can click a color in the original

image, click the color box to access the Color dialog box, or right-click the color box to access the Recent Colors dialog box.

- **Angle** — affects which edges appear light and shadowed. The needle points to the direction of the light source, measured in degrees of rotation around the circle.
- **Intensity** — adjusts the brightness of the directional light. Note that the Ambience value determines the brightness of the entire image before the Intensity effect is applied.
- **Elevation** — shows the angle of elevation of the light source above the image. At a setting of 90 degrees, the light source is positioned directly overhead. As you lower the value, the light source moves closer to the image, producing longer shadows.

## Weave

Edit workspace

The Weave effect makes an image appear to be created with a woven pattern. You can weave the strands loosely or tightly. You can also fill the gaps between strands with any color. You can access the Weave dialog box by choosing **Effects ▶ Texture Effects ▶ Weave**.



The Weave dialog box contains the following controls:

- **Gap size** — sets the pixel size of the area between the woven strands
- **Width** — sets the pixel width of the woven strands
- **Opacity** — controls the strength of the effect

- **Weave color** — lets you choose a weave color. You can click a color in the original image, click the color box to access the Color dialog box, or right-click the color box to access the Recent Colors dialog box.
- **Gap color** — lets you choose a gap color. You can click the color box to access the Color dialog box, or right-click the color box to access the Recent Color dialog box.
- **Fill gaps** — fills the area that appears between the strands with a color. You can unmark the check box to fill the gap area with the image.

## Adding picture frames to images

You can add picture frames to your images to provide an eye-catching final touch. You can choose square or oval frames, modern or classic frames, mats or photo edges, or a variety of other styles. The frame is applied on a separate layer, which can be edited like any other layer.



*You can add a frame around your image.*

### To add a picture frame to an image

Edit workspace

- 1 Choose **Image** ▶ **Picture Frame**.

The Picture Frame dialog box appears.

- 2 In the **Picture Frame** group box, choose a frame from the drop-list.
- 3 In the **Orientation** group box, choose one of the following options:
  - **Frame canvas** — sizes the frame to the canvas. The frame layer is named “Picture Frame” on the Layers palette. Successive frames reside on layers named “Picture Frame 1,” “Picture Frame 2,” and so on.
  - **Frame current layer** — sizes the frame to the current layer (which may have a different size than the canvas). For example, if you are creating a collage of photos for a scrapbook and each photo is on a separate layer, you can frame each photo by choosing this option. The frame layer is named after the original layer with the words “Picture Frame” appended to the name.
- 4 Choose one of the following options:
  - **Frame inside of the image** — resizes the frame to fit within the image canvas
  - **Frame outside of the image** — increases the canvas size to accommodate the frame. The added canvas uses the current background color if the frame is applied to the Background layer. If the frame is applied to any other layer, the extra canvas is transparent.
- 5 Mark any of the following check boxes:
  - **Flip frame** — reverses the frame along its horizontal axis
  - **Mirror frame** — reverses the frame along its vertical axis
  - **Rotate frame right** — lets you rotate the frame clockwise when the image is taller than it is wide
- 6 Click **OK**.



If the width and height differ by a considerable amount, the frame appears thicker along the shorter sides.



If you select a frame in step 2 that contains transparent areas, you can choose to keep these frame area transparent, or you can substitute a color. To maintain frame transparency, mark the **Keep transparent** check box. To substitute a color, unmark the check box, and choose a color from the color box.

## Creating your own effects

You can create your own effects (or filters), which you can save and reuse.

### To create your own effects

Edit workspace

#### 1 Choose **Effects** ▶ **User Defined Filter**.

The User Defined Filter dialog box appears.

#### 2 In the **Load Preset** drop-list, select a filter to use as a starting point.

#### 3 In the **Filter matrix** group box, type or set values in the controls to modify the coefficients that process pixels to create the effect.

#### 4 Click **OK**.

Corel PaintShop Pro applies the effect to the image.

### You can also

Use random values to create an effect

Click the **Randomize Parameters** button  to automatically adjust the coefficients.



## You can also

---

Save a user-defined effect	Click the <b>Save Preset</b> button  , type a name in the <b>Save Preset</b> dialog box, and click <b>OK</b> .
Reuse a user-defined effect	In the <b>Load Preset</b> drop-list, select the user-defined effect.

---

## Combining images

Corel PaintShop Pro lets you combine two images into a third image. The new image is the product of the color data from the two source images combined on a pixel-by-pixel basis according to the arithmetical function you select, such as Add, Subtract, Multiply, or Difference.

If you want to combine images without these functions, you can simply use layers to paste a second image over a background image, and use masking to adjust the transparency. For information about copying and pasting images as layers, see “Cutting, copying, and pasting” on page 84. For information about masking, see “Working with masks” on page 369.

### To combine images by using the Arithmetic command

*Edit workspace*

- 1 Open the two images you want to combine.
- 2 Choose **Image ▶ Arithmetic**.  
The Image Arithmetic dialog box appears.
- 3 In the **Image #1** and **Image #2** drop-lists, select the images to combine.

**Note:** The size of the image you choose in the **Image #1** drop-list determines the size of the new image.

4 In the **Function** group box, choose one of the following options for combining the images:

- **Add** — Image 1 Value + Image 2 Value
- **Subtract** — Image 1 Value – Image 2 Value
- **AND** — Binary And
- **Average** — (Image 1 value + Image 2 Value) / 2
- **Multiply** — Image 1 Value x Image 2 Value
- **Difference** — Absolute Value of (Image 1 Value – Image 2 Value)
- **OR** — Binary Or
- **Darkest** — Minimum of (Image 1 Value, Image 2 Value)
- **Lightest** — Maximum of (Image 1 Value, Image 2 Value)
- **XOR** - Exclusive Or

The color data from the two images is combined on a pixel-by-pixel basis according to the function you choose.

5 From the **Channel** group box, do one of the following:

- To produce a 24-bit image, mark the **All channels** check box to use all the color channels in both images to produce a 24-bit image
- To produce a grayscale image, choose a color channel option for each image. In the **Modifiers** group box, type or set values in the following controls:
- **Divisor** — divides the color values by the value you specify. This value can reduce the effects of the other selections.
- **Bias** — shifts each color value by amount you specify.

These modifiers are applied to the color values produced by the Formula and the Channel selections.

- 6 Mark or unmark the **Clip color values** check box to determine how Corel PaintShop Pro handles final color values that are greater than 255 and less than 0.

When the **Clip color values** check box is marked, color values less than 0 become 0, and color values greater than 0 become 255.

When the **Clip color values** check box is unmarked, color values less than 0 are calculated as 256 plus the value, and color values greater than 0 are calculated as 256 minus the value.

- 7 Click **OK**.

## Using the Picture Tube tool

You can use the Picture Tube tool to paint with a collection of objects. For example, you can add butterflies and beetles to a picnic setting or frame a picture with flowers. You can use one of the picture tubes included with Corel PaintShop Pro or create your own.



*The Picture Tube tool lets you apply various preset images to your photos to create unique effects.*

Picture tubes are PspTube files. Each picture tube file is made up of a series of images arranged in rows and columns, called cells. Picture tubes may have any number of cells. As you paint with the Picture Tube tool, Corel PaintShop Pro paints one image from the picture tube after another. Many picture tubes create discrete images (such as zoo

animals), and others create the effect of a continuous image (such as grass).



*Each picture tube file contains a series of images.*

To make picture tube elements easier to edit, it is helpful to paint them on a separate layer.

***Important!*** *You cannot use the Picture Tube tool on vector layers.*

### Where can I get more picture tubes?

You can create your own picture tubes. You can use picture tubes from a previous version of the application. For more information, see “To use picture tubes from previous versions of the application” on page 524.

You can also download free picture tubes from the Web by checking the Corel website ([www.corel.com](http://www.corel.com)) or by using the keyword phrase “free picture tubes” in an online search engine.

***Important!*** *This tool works only on raster layers in grayscale and 16 million-color images. Using this tool on a 256-color or lower raster image automatically promotes the image to the appropriate color depth. To convert a vector layer to a raster layer, choose **Layers ▶ Convert to Raster Layer**. For more information about increasing the color depth of an image, see “Increasing the color depth of an image” on page 632.*

## Picture Tube settings

When you click the **Settings** button  on the Tool Options palette, the Picture Tube Settings dialog box appears. You can use this dialog box to update the current Tool Options palette settings and to modify the look of the current picture tube. However, you can also make the settings permanent by marking the **Save as default for this Picture Tube** option.

- **Current Picture Tube name and path** — The name and path of the picture tube appear at the top of this dialog box.
- **Cell arrangement** — The **Cells across** and **Cells down** fields display the current cell layout of the tube. The ranges for these values depend on how the tube was created. The **Total cells** field shows the product of multiplying the **Cells across** value by the **Cells down** value.
- **Placement options** — Modifying any of these settings updates the corresponding setting on the Tool Options palette. Note that the Scale setting is only available for some picture tubes.
- **Save as default for this Picture Tube** — Mark this check box if you want to save any modifications made in the Picture Tube Settings dialog box. If you do not mark this check box, the changes affect only the current use of the picture tube.

## To paint with a picture tube

Edit workspace

- 1 On the Tools toolbar, choose the **Picture Tube** tool .
- 2 On the Tool Options palette, select a picture tube from the Picture Tube drop-list.

**Note:** Most picture tube previews show the first image rather than all images in the picture tube. To view all images, select the desired picture tube and then paint with it, or open the **.PspTube** file in Corel PaintShop Pro.

- 3 If necessary, adjust the following:
  - **Scale** — determines the percentage (10% to 250%) for reducing or enlarging each image in the picture tube and scaling the step
  - **Step** — determines the distance in pixels (1 to 500) between the centers of each picture tube cell that you paint
  - **Placement mode** — determines how the images are placed. Choose **Continuous** to space the images evenly by step size, or choose **Random** to randomly space the images, with intervals ranging from 1 pixel to the step size.
  - **Selection mode** — determines how Corel PaintShop Pro selects images from the cells within the picture tube file. **Angular** selects images based on the direction you drag; **Incremental** selects images one by one from top left to bottom right; **Pressure** selects images based on the pressure you apply on a pressure-sensitive tablet; **Random** selects images randomly; and **Velocity** selects images based on the speed with which you drag.
- 4 In the image window, click to paint with one picture tube image, or drag to paint with multiple picture tube images.



You can make further changes to the behavior of the current picture tube by clicking the **Settings** button  on the Tool Options palette and adjusting settings in the Picture Tube Settings dialog box.

## To create a picture tube

Edit workspace

- 1 Choose **View ▶ Change Grid, Guide & Snap Properties**.
- 2 Click the **Grid** tab.
- 3 In the **Current image settings** group box, type or set the **Horizontal grids** and **Vertical grids**, and click **OK**.

**Note:** Values for the grid positions are the values in pixels for the width and height of the cells. Images must be no larger than this cell size.

**4** Choose **File ▶ New**.

The New Image dialog box appears.

**5** Set the following options:

- **Image Dimensions** — sets a width and height (in pixels) that are multiples of the horizontal and vertical grid spacing. The width and height of the image determine the total number of cells in the image. For example, if the grid spacing is 100 pixels, you can create an image that is 400 pixels wide by 300 pixels high. These dimensions would produce 12 cells (four across and three down).
- **Image Characteristics** — Choose **Raster Background** as the layer type, **8 bits/channel** or **16 bits/channel** as the Color depth, and mark the **Transparent** check box.

**6** Click **OK**.

If the grid is not visible, choose **View ▶ Grid**.

**7** Create one image in each grid square. These squares are the picture tube cells.

To change the size of cells, change the grid size, and then use the **Canvas Size** command.

**8** Choose **File ▶ Export ▶ Picture Tube**.

The Export Picture Tube dialog box appears.

**9** Set the following options:

- **Cell arrangement** — Enter the number of cells across and down. Set these fields to match your arrangement of images in step 7. The **Total cells** field should match the number of images you placed in the tube file.

- **Placement options** — Choose the default options for this picture tube. You can change these options when you apply the picture tube.
- **Tube name** — Enter the filename of the tube. The extension **.PspTube** is automatically added to the filename.

10 Click **OK**.





You can make further changes to the behavior of the current picture tube by clicking the **Settings** button  on the Tool Options palette and adjusting settings in the Picture Tube Settings dialog box.

If you want to use one image as a paint brush, export the image as a picture tube. Use a cell arrangement of one cell across by one cell down. The image must contain one raster layer that is not the background. To promote the background to a layer, choose **Layers ▶ Promote Background Layer**. Choose the Picture Tube tool, and select the new picture tube you created.

## To use picture tubes from previous versions of the application

Edit workspace

- 1 Choose the **Picture Tube** tool  from the Tools toolbar.
- 2 On the Tool Options palette, click the **Presets** drop-list, and click the **File Locations** button .
- 3 In the File Locations dialog box, choose **Picture Tubes** from the **File types** list.
- 4 Click the **Add** button.

The Browse for Folder dialog box appears.

- 5 Choose the folder where the previous versions of the picture tubes are stored, and click **OK**.

The folder path is added to the Picture Tube folders list.



6 Click OK.

## Warping images

You can distort image areas by using the warp brushes on image pixels to produce a warping effect. You can twirl areas of images, contract or expand parts of images, and create many interesting effects. The effect of the Warp Brush is often time-dependent, which means that the longer you hold the brush over an area, the more the brush produces the effect.



*The Warp Brush tool can be used to create caricatures.*

You can also warp images by using a grid. When you use the Mesh Warp tool, a grid or mesh is placed on the image. The grid intersections have mesh points, or nodes, that you drag to create deformations.









For more information about warping by using a grid, see “To warp image areas by using a grid” on page 527.

### To warp image areas by using a brush

Edit workspace

- 1 On the Tools toolbar, choose the **Warp Brush** tool .

2 On the Tool Options palette, choose the type of warp in the **Warp Modes** group box:

- **Push**  — pushes pixels in the direction of the stroke for an effect similar to smearing paint. This warp mode is time-independent.
- **Expand**  — pushes pixels away from the center of the brush
- **Contract**  — pulls pixels into the center of the brush
- **Right Twirl**  — rotates pixels clockwise around the center of the brush
- **Left Twirl**  — rotates pixels counterclockwise around the center of the brush
- **Noise**  — causes random movements of pixels under the brush
- **Iron Out**  — removes unapplied warps. This warp mode is time-independent.
- **Unwarp**  — removes unapplied warps

3 Specify the brush options, such as size and hardness.

**Note:** Unlike other brushes, the size of the Warp Brush tool can be adjusted only by using the control on the Tool Options palette, not by using the keyboard.

4 Type or set a value in the **Strength** control to determine the strength of the warping effect.

Full strength is 100%; minimum strength is 1%.

5 Choose settings for the **Edge mode**, **Draft quality**, and **Final apply** controls.

6 Drag in the image.



For more information about setting brush options, see “Choosing brush options” on page 595.



For the time-dependent warp modes, you can also place the pointer at one position (instead of dragging) and hold down the mouse button to repeat the effect in one area.

To unwarp an area, click the **Iron Out** button or **Unwarp** button on the Tools Options palette, and click over the area that you want to restore.

## To warp image areas by using a grid

Edit workspace

- 1 On the Tools toolbar, select the **Mesh Warp Tool** .
- 2 Drag the nodes in one of the following ways to deform the image:
  - Drag a node to move it.
  - Press **Shift** while dragging a node to move the entire row or column.
  - Press **Ctrl** while dragging a node to deform the row or column into a smooth curve.
- 3 Choose settings from the Tool Options palette:
  - **Mesh horizontal** and **Mesh vertical** — specifies the number of mesh lines within the frame. The border lines are not counted. You can change the grid size as you work. Entering new Mesh values reconfigures the grid and returns it to the original position. The image retains any deformations you have made.
  - **Symmetric** — creates a grid that evenly covers the image. If your image is not square, there will be different values for Mesh horizontal and Mesh vertical. Unmark this check box to adjust the **Mesh horizontal** and **Mesh vertical** settings independently.
  - **Show mesh** — hides and shows the mesh warp grid.
  - **Draft Quality** — specifies the quality of the preview that appears while you edit the mesh nodes. Increasing the quality can slow the warping process in large images.

- **Final Apply** — determines the quality of the applied effect. Unmark the **Best Quality** check box to create a finished mesh warp at the lower quality of the mesh preview.

4 Click **Apply** on the Tool Options palette.



You can save the position of the mesh nodes (the deformation map) to apply the deformation to other images. For information about saving and loading deformation maps, see “Working with deformation maps” on page 528.





You can also double-click the image to apply the effect. Choose **Edit ▶ Undo** to undo changes to the mesh as you edit. To cancel the mesh warp before it is applied, click **Cancel**.

## Working with deformation maps

You can save the deformations you create with the Mesh Warp tool to warp other images. Corel PaintShop Pro creates a deformation map file that contains the positions of the nodes and the number of mesh lines. You can save the mesh during the warping process or after you have applied the deformation. After you save a deformation map, you can load it into other images.

### To save a deformation map

Edit workspace

- 1 On the Tools toolbar, choose the **Warp Brush** tool .
- 2 Drag the cursor across the image.
- 3 On the Tool Options palette, in the **Deformation map** group box, click the **Save deformation map** button .

The Save Deformation Map dialog box appears.

- 4 In the **New deformation map** group box, type a name for the map file.
- 5 In the **Deformation map** group box, choose a deformation map style from the drop-list.
- 6 In the **Checkerboard size** drop-list, choose a checkerboard size to help you to preview the deformation effect.



**Note:** This information is not saved with the map file.

- 7 Click **Save**.

The file is added to the default Deformation Maps folder.

## To load a deformation map

Edit workspace

- 1 On the Tools toolbar, choose the **Warp Brush** tool .
  - 2 On the Tool Options palette, choose one of the following options from the **Edge mode** drop-list:
    - **Background** — fills areas between the edge of the image and the edge of the warp with the current background color
    - **Fixed** — fills areas between the edge of the image and the edge of the warp with replicated edge pixels
    - **Wraparound** — fills areas between the edge of the image and the edge of the warp with material from the opposite side of the image
  - 3 On the Tool Options palette, click the **Open deformation map** button .
- The Load Deformation Map dialog box appears.
- 4 In the **Deformation map** group box, choose a deformation map style from the drop-list.
  - 5 In the **Operation** group box, choose one of the following options:

- **Replace current map** — replaces the existing mesh nodes with the new map. Any adjustments you have made but not applied are lost.
  - **Add to current map** — adds the settings from the new deformation map to the mesh nodes. Any adjustments you have made are retained.
- 6 In the **Mapping** group box, choose one of the following options:
    - **Fit to canvas** — adjusts to fit the image canvas
    - **Fit to layer** — adjusts to fit the current layer
    - **Current size centered on** — retains original map size and positions it in the center of the canvas or layer
  - 7 In the **Preview** group box, choose a checkerboard size from the drop-list to obtain the best preview of the deformation.
  - 8 Click **Load**.



Corel PaintShop Pro lets you add text to images and create interesting text effects.

This section presents the following topics:

- Applying text
- Formatting text
- Fitting text to a path
- Moving text
- Applying effects to text
- Converting text to curves
- Creating a text cutout filled with an image
- Filling text with image patterns
- Sizing and transforming text

## Applying text

Corel PaintShop Pro lets you apply different types of text to your images. You can apply vector text, raster text, and text as a selection. The type of text you apply depends on the effect you want to create.

### Vector text

Vector text, which is used in most instances, is the most versatile type of text because you can edit the text characters at any time. For example, you can change the words, font type, style, and alignment.

Unlike raster text, vector text retains its crisp, sharp edges when you resize it. For more information about vector objects, see “Drawing and editing vector objects” on page 551.



*You can add text to your photos.*

When you use raster-only tools, such as the Mesh Warp tool, or apply raster-only commands, such as an effect, the vector text is converted to a raster layer, and it can no longer be edited as text.

## **Raster text**

You cannot edit raster text after you apply it. Therefore, you should not apply it unless you know you won't need to change the words and formatting. You create raster text as a floating selection on a new raster layer, so you can easily move and transform it before you apply it to your image. When you defloat raster text, the text is merged with the underlying raster layer. If a vector layer is active when you defloat the raster text, Corel PaintShop Pro creates a new raster layer.

## **Text selection**

You can create a selection in the shape of text and edit it as you would any other selection. You can use a text selection to create special effects; for example, you can fill the characters in a text selection with an image. You can also fill text with an image by using the Text Cutter. For more information, see “Creating a text cutout filled with an image” on page 546. As with raster text, you cannot edit selection-based text.



For more information about selections, see “Working with selections” on page 291.



## Text formatting options

When you create text, you can specify formatting options such as font, font size, and alignment, as well as character and line spacing. For more information about text formatting options see “Formatting text” on page 535.

You can delete vector, raster, or selection-based text at any time.

## To create text

Edit workspace

- 1 On the Tools toolbar, choose the **Text** tool .
- 2 On the Materials palette, click the **Foreground and Stroke Properties** box, and choose a color for the text outline.  
If the Materials palette is not displayed, choose **View ▶ Palettes ▶ Materials**.  
If you want to create text with no outline, click the **Transparent** button  below the Foreground and Stroke Properties box.
- 3 On the Materials palette, click the **Background and Stroke Properties** box, and choose a color for the text fill.  
If you want to create hollow text, click the **Transparent** button  below the Background and Fill Properties box, and on the Tool Options palette, set the **Stroke width** control to **1.0** or greater.
- 4 On the Tool Options palette, choose one of the following text types from the **Create As** drop-list:
  - **Vector** — creates fully editable text that resides on a vector layer. This text type is the default and is used in most instances.
  - **Selection** — creates a selection marquee in the shape of the text characters. The marquee is filled with the underlying layer.

- **Floating** — creates raster text as a floating selection. The selection can be moved, but the text characters cannot be edited.
- 5 On the Tool Options palette, choose a font, font size, units, and font style.  
**Note:** The Units drop-list offers two options — Points (for print output) and Pixels (for Web output).
  - 6 In the image window, click where you want the text to appear, type the text, and click the **Apply** button  on the Tool Options palette.  
A bounding box appears around the text.
  - 7 Do any of the following to adjust the text position:
    - Position the pointer in the centre of the bounding box until the pointer changes its shape to a four-way arrow, and drag the text to the desired location.
    - Position the pointer over a corner of the bounding box until the pointer changes its shape to a two-way arrow, and drag up and down to rotate the text.



For information about using the Materials palette to choose colors for the text outline and fill, see “Using the Materials palette” on page 385.



You can also apply the text after you have typed it by double-clicking the area outside the text object.

## To delete text

Edit workspace

- 1 On the Tools toolbar, choose the **Pick** tool .
- 2 Click the vector text you want to delete to select it.

### 3 Press **Delete**.



You can also use the following text selection methods: double-click a word to select it, triple-click a line to select it, and quadruple-click in the text or press **Ctrl + A** to select the entire text.

## Formatting text

The text formatting options in Corel PaintShop Pro let you control the appearance of text. You can set these options when you create vector, raster, or selection text. If you create vector text, you can reformat the text at any time by changing your text formatting settings. You cannot change the characters or formatting of raster text. You can modify raster text only by using the Pick tool.

You can use the following text options to format your text:

- **Font, Size, Units, and Font Style** — let you choose a typeface, type size, units based on intended output (print or Web), and type style (bold, italic, underline, or strikethrough)
- **Alignment** — lets you center multiple lines of text or align them on a left or right margin
- **Direction** — lets you set the horizontal or vertical direction of the text
- **Kerning** — lets you change the space between characters
- **Leading** — lets you change the line spacing
- **Tracking** — lets you set equal spacing between characters
- **Anti-alias** — lets you smooth the edges of text characters



You can also change the color of vector text. For information about using the Materials palette to choose colors for the text outline and fill, see “Using the Materials palette” on page 385.





## How can you identify vector text?

Vector text, like other vector objects, can be identified by the vector icon  that appears next to the text in the Layers palette.

## To change font attributes





Edit workspace

- 1 On the Tools toolbar, choose the **Text** tool .
- 2 Select the vector text characters you want to change by dragging over them.  
**Note:** You can also select the entire text by pressing **Ctrl + A**.
- 3 On the Tool Options palette, perform a task from the following table, and click the **Apply changes** button .

To	Do the following
Change the font	Choose an option from the <b>Font</b> drop-list.
Change the font size	Choose an option from the <b>Size</b> drop-list.
Change the units of measurement for the font	From the <b>Units</b> drop-list, choose <b>Points</b> for print output or <b>Pixels</b> for Web output.
Apply bold formatting to text	Click the <b>Bold</b> button  .
Apply italic formatting to text	Click the <b>Italic</b> button  .
Underline the text	Click the <b>Underline</b> button  .
Apply a line through text	Click the <b>Strikethrough</b> button  .





## To change text alignment

Edit workspace

- 1 On the Tools toolbar, choose the **Text** tool .
- 2 Select the text object you want to align by dragging over it.  
**Note:** You can also select the entire text by pressing **Ctrl + A**.
- 3 On the Tool Options palette, choose one of the following buttons:
  -  — aligns the left edge of each text line to the initial cursor position
  -  — centers each text line on the initial cursor position
  -  — aligns the right edge of each text line to the initial cursor position
- 4 On the Tool Options palette, click the **Apply** button .



## To set text direction

Edit workspace

- 1 On the Tools toolbar, choose the **Text** tool .
- 2 Select the text object you want to reposition by dragging over it.  
**Note:** You can also select the entire block of text by pressing **Ctrl + A**.
- 3 On the Tool Options palette, choose one of the following options from the **Direction** drop-list:
  - **Horizontal and Down**  — positions text horizontally, with subsequent lines below the top line
  - **Vertical and Left**  — positions each character vertically, with subsequent lines to the left of the top line
  - **Vertical and Right**  — positions each character vertically, with subsequent lines to the right of the top line
- 4 On the Tool Options palette, click the **Apply** button .

## To change horizontal spacing between characters

Edit workspace

- 1 On the Tools toolbar, choose the **Text** tool .
- 2 Select the text characters whose spacing you want to change by dragging over them.  
**Note:** You can also select the entire text by pressing **Ctrl + A**.
- 3 On the Tool Options palette, type or set a value in the **Kerning** control.  
Positive values increase the spacing; negative values decrease the spacing.
- 4 On the Tool Options palette, click the **Apply** button .





Kerning values are expressed as 1 being equal to one em space — the width of capital letter M for a given font and font size.



You can use the built-in kerning values for the current font by marking the **Auto Kern** check box.



## To change vertical spacing between lines of text

Edit workspace

- 1 On the Tools toolbar, choose the **Text** tool .
- 2 Select the text lines whose spacing you want to adjust by dragging over them.  
**Note:** You can also select the entire block or text by pressing **Ctrl + A**.
- 3 On the Tool Options palette, type or set a value in the **Leading** control.  
Positive values increase the spacing; negative values decrease the spacing.
- 4 On the Tool Options palette, click the **Apply** button .



## To set equal spacing between characters

Edit workspace

- 1 On the Tools toolbar, choose the **Text** tool .
- 2 Select the text characters whose spacing you want to adjust by dragging over them.  
**Note:** You can also select the entire text by pressing **Ctrl + A**.
- 3 On the Tool Options palette, type or set a value in the **Tracking** control.
- 4 On the Tool Options palette, click the **Apply** button .

## To smooth jagged edges in text

Edit workspace

- 1 On the Tools toolbar, choose the **Text** tool .
- 2 Select the text object whose edges you want to adjust by dragging over it.  
**Note:** You can also select the entire text by pressing **Ctrl + A**.
- 3 On the Tool Options palette, choose an option from the **Anti-alias** drop-list:
  - **Off** — applies no anti-aliasing (edges appear jagged)
  - **Sharp** — applies a slight degree of edge smoothing
  - **Smooth** — applies a stronger degree of edge smoothing
- 4 On the Tool Options palette, click the **Apply** button .



Anti-aliasing may increase the number of colors in an image, which may cause stray colors to appear along the edges of text. Anti-aliasing may also make it difficult to reduce the file size and to maintain image quality.

## Fitting text to a path

Every vector object has a path that defines its shape. You can fit vector text to a path to create fun and interesting effects.

Corel PaintShop Pro aligns the text along the path, starting from the spot where you click to insert it. You can also set the alignment style for the text: left-aligned text starts where you click; centered text is centered on the spot where you click; and right-aligned text ends where you click. When you fit your text to a path, you can adjust the distance between the text and the path.

Text is displayed differently on open and closed paths. Open paths are lines on which the start and end nodes do not meet; closed paths are shapes such as circles, squares, and rectangles. On open paths, text that is longer than the path hangs from the end. The angle of the last line segment determines the direction in which the text hangs. On closed paths, text that is longer than the path wraps around itself. For more information about lines and shapes, see “Editing shapes” on page 563.

### To fit text to a path

Edit workspace

- 1 Create a vector line or shape.
- 2 Click the **Text** tool .
- 3 On the Tool Options palette, choose **Vector** from the **Create As** drop-list, and set the other text controls.  
If the Materials palette is not displayed, choose **View ▶ Palettes ▶ Materials**.
- 4 On the Materials palette, click the **Foreground and Stroke properties** box, and choose a color for the text outline.



- 5 Click the **Background and Fill properties** area, and choose a color for the text fill.
- 6 Click the line or shape.  
**Note:** To position the text on a vector object or path without attaching it to the object or path, hold down **Alt** and click the path or shape.
- 7 Click on the image where you want the text to appear, and type the text.
- 8 On the Tool Options palette, click the **Apply** button .



If you want to warp the text around the curved section of a path, mark the **Warp text** check box on the Tool Options palette. If the path is not curved, the effect is not apparent. Warping is set on a per-character basis, so you can warp specific characters in a text block.

## To attach an unattached text object to a path

Edit workspace

- 1 Choose the **Pick** tool .
- 2 Select the vector object.
- 3 Hold down **Shift**, and select the vector text.  
Both the text and the vector object are selected.
- 4 Choose **Objects ▶ Fit Text to Path**.



After you align text to a vector object, you can make the object invisible. On the Layers palette, click the **Visibility Toggle** button  next to the object.

## To detach text from its associated path



Edit workspace

- 1 Choose the **Pick** tool .
- 2 Select the text.
- 3 Choose **Objects** ▶ **Detach Object from Path**.

**Note:** The **Detach Object from Path** command is available only if you have selected a text object that is fitted to a path.

## To adjust the position of text fitted to a path

Edit workspace

- 1 On the Tools toolbar, choose the **Text** tool .
- 2 Select the text whose position you want to adjust by dragging over it.  
**Note:** You can also select the entire text by pressing **Ctrl + A**.
- 3 On the Tool Options palette, set a value in the **Offset** control.  
Positive values position the text above the path; negative values position the text below the path.
- 4 On the Tool Options palette, click the **Apply** button .



## Moving text

You can move vector and raster text anywhere in an image. You can move the text after it is fitted to the path by selecting it and dragging it along the path. Corel PaintShop Pro aligns text based on the nearest point where the text meets the path.

***Important!** To move raster text that is on a layer with other raster information, such as raster shapes or brushstrokes, you must isolate the text. You can use a selection tool, such as the Magic Wand tool, to select and move the text. For more information about making selections, see “Creating selections” on page 292.*

### To move text

Edit workspace

- 1 On the Tools toolbar, choose the **Pick** tool .
- 2 Click the text you want to move.  
A bounding box surrounds the text.
- 3 Position your cursor over the selected text, until it changes its shape to a four-way arrow , and drag the text anywhere in the image.



You can also move text to another layer by cutting and pasting it onto another layer.

### To move text along a path

Edit workspace

- 1 Choose the **Pick** tool .
- 2 Click the text you want to move.  
A bounding box appears around the text.

- 3 Position your cursor over the selected text, until it changes its shape to a four-way arrow , and drag the text to the desired location.

**Note:** As you drag the text, a small, square icon moves with it. This icon indicates one of the following:

- the start of the text if the text was left-aligned
- the midpoint of the text if the text was centered
- the end of the text if the text was right-aligned

## Applying effects to text

You can use raster text to create an unlimited variety of text effects. For example, you can apply a drop shadow or a beveled edge, transform text into brushstrokes, or apply a colored-chalk effect. To apply an effect to vector text, you must first convert the vector text to raster text.

### To apply effects to raster text

Edit workspace

- 1 Apply raster text to a transparent layer on an image.
- 2 On the Tools toolbar, choose the **Magic Wand** tool .
- 3 Select the text.
- 4 Choose the **Effects** menu, and select an effect.



For information about layers, see “Working with layers” on page 325. For information about applying text to images, see “Applying text” on page 531.

### To apply effects to vector text

Edit workspace

- 1 On the Tools toolbar, choose the **Pick** tool .
- 2 Select the text.

- 3 Choose **Selections ▶ From Vector Object**.
- 4 Choose **Edit ▶ Paste As New Layer**.
- 5 On the Tool Options palette, choose the **Magic Wand** tool .
- 6 Select the text.
- 7 Choose the **Effects** menu, and select an effect.

## Converting text to curves

You can edit vector text by converting it to curves and then adding, deleting, and moving nodes. Nodes are the tiny squares that appear along the object's outline.

You can convert letters to individual curve objects, or you can convert the entire string of text into one curve object, with each letter as a separate contour within the object path.

### To convert vector text to curves

Edit workspace

- 1 On the Tools toolbar, choose the **Pick** tool .
- 2 Select the text.
- 3 Do one of the following:
  - To convert the entire text object into one vector object, choose **Objects ▶ Convert Text to Curves ▶ As Single Shape**. This command produces one path containing a contour for each letter.
  - To convert each letter to a separate vector object with its own path, choose **Objects ▶ Convert Text to Curves ▶ As Character Shapes**. A vector layer is created for each letter, and the layers are grouped in the Layers palette.



If you convert each letter to a separate vector object, you must select the letters individually in order to edit the nodes.

You can edit a curve object by using the Pen tool  in Edit mode. For more information, see “Adding and closing contours” on page 578.

## Creating a text cutout filled with an image

You can use the Text Cutter option to create a text cutout that is filled with the underlying photo or imagery. The effect is similar to using a clipping mask, except the cutout object is created as a new file with a transparent background—perfect for collage, scrapbook, or other creative photo projects.



*You can use the Text Cutter option to create a text cutout that is filled with the underlying photo or imagery.*

## To create a text cutout

- 1 In the Edit workspace, open an image that you want to use as a fill.
- 2 On the Tools toolbar, click the **Text** tool .
- 3 On the Tool Options palette, set the text options.
- 4 In the image window, click where you want to position the text, and type the text.

If you resize or reposition the text with the **Pick Tool** , reactivate text mode by clicking the **Text Tool** and clicking inside the text.

- 5 On the Tool Options palette, click the **Text Cutter** button .



The text cutout is filled with the underlying imagery and is created as a new file with a transparent background. A layer and mask is also created on the current image.

## Filling text with image patterns

You can fill text with one image or you can fill it with repeated images to create a pattern.

### To fill text with one image

Edit workspace

- 1 Open a copy of the image.
- 2 On the Tools toolbar, choose the **Text** tool .
- 3 On the Tool Options palette, choose **Selection** from the **Create As** drop-list, and set the other text controls.
- 4 In the image window, click where you want to create the text selection, and type the text.
- 5 On the Tool Options palette, click the **Apply changes** button .
- 6 Copy the text selection to a new image.



For information about applying text, see “Applying text” on page 531.

## To fill text with a repeated image

Edit workspace

- 1 Open the image you want to use to fill the text.
- 2 On the Materials palette, click the **Background and Fill properties** box.
- 3 In the Material properties dialog box, click the **Pattern** tab.
- 4 Choose the image from the drop-list.
- 5 Apply text to the image.



For information about applying text, see “Applying text” on page 531.





## Sizing and transforming text

You can transform raster and vector text interactively. For example, you can resize, rotate, shear, distort, or apply perspective to text.

You can also resize and reshape vector text by editing its nodes and contours. For more information, see “Working with nodes” on page 564.

Edit workspace

- 1 Open a copy of the image.
- 2 On the Tools toolbar, choose the **Text** tool .
- 3 On the Tool Options palette, choose **Selection** from the **Create As** drop-list, and set the other text controls.
- 4 In the image window, click where you want to create the text selection, and type the text.
- 5 On the Tool Options palette, click the **Apply changes** button .
- 6 Copy the text selection to a new image.

### To resize and transform text

Edit workspace

- 1 On the Layers palette, choose a layer.
- 2 On the Tools toolbar, choose the **Pick** tool , and select the text. A bounding box with handles appears on the selection or the layer.
- 3 Drag a corner handle to resize the text.  
If you want to change the current proportions, right-click and drag a handle.
- 4 Perform any of the actions in the following table to transform the text.

To	Do the following
Move the entire text block	Drag the bounding box.
Change the center of rotation	Drag the rotation pivot point.
Rotate the text	Drag the rotation handle
Change the perspective symmetrically	Hold down <b>Ctrl</b> and drag a corner handle horizontally or vertically.
Change the perspective asymmetrically	Hold down <b>Shift</b> and drag a corner handle.
To shear text	Hold down <b>Shift</b> while dragging a side handle.
To distort text	Hold down <b>Ctrl</b> and <b>Shift</b> while dragging a handle.



To make the deform handles on a layer easier to see, drag the corner of the image window to make it larger than the image.

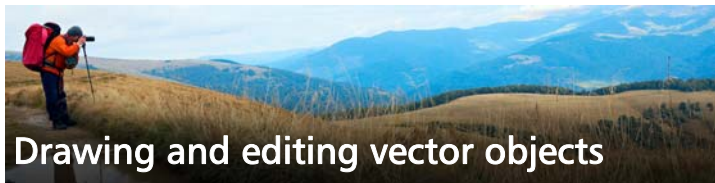

You can use Corel PaintShop Pro drawing tools to create any type of object — from simple lines and shapes to complex illustrations.

This section presents the following topics:

- Understanding raster and vector objects
- Selecting vector objects
- Drawing rectangles and squares
- Drawing circles and ellipses
- Drawing symmetric shapes
- Creating preset shapes
- Filling cutout shapes with images
- Editing shapes
- Saving shapes as presets
- Working with nodes
- Sizing, shaping, and rotating vector objects
- Aligning, distributing, and arranging vector objects
- Grouping and ungrouping vector objects
- Converting objects to paths
- Adding and closing contours
- Editing contours and paths
- Drawing lines
- Saving custom line styles

- Drawing curves
- Modifying lines and curves
- Copying and moving vector objects

## Understanding raster and vector objects

When you draw raster objects, you are really painting on a raster layer. Even though you create a raster object in the same way as a vector object, the result is a pixel-based shape. You can edit the pixels with raster editing tools.

***Important!** You can only draw raster objects on raster layers. If you draw a raster object on a vector layer, Corel PaintShop Pro creates a new raster layer for your object.*

A vector object's properties — such as its outline color, fill color, size, and location — can be easily changed. You can also edit the paths, contours, line segments, and nodes that make up vector objects.

***Important!** You can only draw vector objects on vector layers. If you try to draw a vector object on a raster layer, Corel PaintShop Pro creates a new vector layer for the vector object.*

For more information on vector and raster objects, see “Creating images” on page 69. For information about vector, floating, and selecting text, see “Working with text” on page 531.

### The anatomy of a vector object

In order to understand vector objects, you must be familiar with the following terms.

- **Object** — anything you create with the Pen or Preset Shape tool. Each object is represented by its own bounding box. An object has properties you can control such as line style and fill color. Each

object contains one path made up of contours and nodes. For more information, see “Aligning, distributing, and arranging vector objects” on page 572.

- **Path** — includes all of the contours in an object. The properties of the path are controlled by the object’s properties. A path’s direction flows from its start to its end point. Some paths are closed, in which their start and end points are the same.

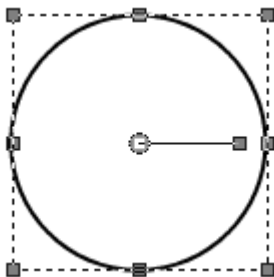

*An example of a closed path*

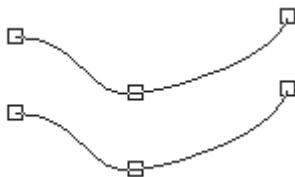

*An example of an open path*

- **Contour** — contains at least one line segment. A contour can be open or closed. Some of a contour’s properties are determined by the object’s properties, such as the line style, fill color, and anti-aliasing.

- **Node** — a point on a path or contour that lets you define its shape. For more information about nodes, see “Working with nodes” on page 564.



*An example of a contour*

- **Line Segment** — the straight or curved line between two nodes. For more information, see “Drawing lines” on page 582.

## Selecting vector objects

You must select a vector object in order to edit it. You can select one or more objects on the same layer, or you can select objects on different layers. You can select vector objects by using the Pick tool or by using the Layers palette. The Pick tool lets you select one or more vector objects quickly. The Layers palette lets you select vector objects regardless of whether they overlap or are currently showing in the image window. For more information about showing and hiding layers, see “Viewing layers” on page 344.

### To select vector objects with the Pick tool

Edit workspace

- 1 On the Tools toolbar, choose the **Pick** tool .
- 2 Click the object you want to select.



If you want to select multiple objects, hold down **Shift**, and click the objects.

## To select vector objects from the Layer palette

Edit workspace

- 1 On the Layers palette, click the plus sign (+) next to a layer to view all of its objects.
- 2 Click the layer name for the vector object.  
The layer name appears in bold type.





If you want to select multiple objects, hold down **Shift** and click each object name.

## Drawing rectangles and squares

You can draw squares and rectangles.

### To draw a rectangle or square

Edit workspace

- 1 On the Tools toolbar, select the **Rectangle** tool .  
**Note:** If you want to place the rectangle or square on the current vector layer, mark the **Create on Vector** check box on the Tool Options palette. If no vector layer exists, marking this check box creates one for the rectangle or square. If this check box is unmarked, the rectangle or square is placed on a raster layer. Placing a rectangle or square on a vector layer makes it easier to edit.
- 2 On the Materials palette, click the **Background and Fill properties** box, and choose a fill color.
- 3 Click the **Foreground and Stroke properties** box, and choose an outline color.
- 4 On the Tool Options palette, click one of the following buttons:
  - **Draw Rectangle** 
  - **Draw Square** 

If you want to display the shape's nodes, mark the **Show Nodes** check box.

- 5 Drag to draw the shape.
- 6 Click the **Apply** button .

## You can also

---

Set the radii for the shape's corners Type or set values in the **Horizontal Radius** and **Vertical Radius** controls.

---

Choose a line style and width Choose an option from the **Line Style** drop-list, and type or set a value in the **Width** control beside the drop-list.

---

Smooth the shape's edges Mark the **Anti-alias** check box.

---

Change the way the line segments join Choose an option from the **Join** drop-list. If you choose **Miter join**, you can also type or set a value in the **Miter Limit** control.

---

Size the shape Mark the **Show nodes** check box. Type or set values in the **Width** and **Height** controls.

---

Move the shape Mark the **Show nodes** check box. Type or set values in the **Left** and **Top** controls.

---



You can save your settings as a preset. For more information, see "Using and creating presets" on page 721.







## Drawing circles and ellipses

You can draw circles and ellipses.

### To draw a circle or ellipse

Edit workspace

- 1 On the Tools toolbar, select the **Ellipse** tool .  
**Note:** If you want to place the circle or ellipse on the current vector layer, mark the **Create on Vector** check box on the Tool Options palette. If no vector layer exists, marking this check box creates one for the circle or ellipse. If this check box is unmarked, the circle or ellipse is placed on a raster layer. Placing a circle or ellipse on a vector layer makes it easier to edit.
- 2 On the Materials palette, click the **Background and Fill properties** box, and choose a fill color.
- 3 Click the **Foreground and Stroke properties** box, and choose an outline color.
- 4 On the Tool Options palette, click one of the following buttons:
  - **Draw Circle** 
  - **Draw Ellipse** If you want to display the shape's nodes, mark the **Show Nodes** check box.
- 5 Drag to draw the shape.
- 6 Click the **Apply** button .

### You can also

---

Set the radii

Mark the **Show Nodes** check box. Type or set values in the **Radius X** and **Radius Y** controls.

---

## You can also

---

Set the center horizontal (center X) and vertical (center Y) position

Mark the **Show Nodes** check box. Type or set values in the **Center X** and **Center Y** controls.

---



You can save Tool Options palette settings as presets. For more information, see “Using and creating presets” on page 721.



If you have not displayed nodes in the shape, you can still set the radii and the center horizontal and vertical positions by clicking the **Edit Mode** button  on the Tools Options palette.

## Drawing symmetric shapes

You can draw polygons and stars.

### To draw a symmetric shape

Edit workspace

- 1 On the Tools toolbar, select the **Symmetric Shape** tool .

**Note:** If you want to place the symmetric shape on the current vector layer, mark the **Create on Vector** check box on the Tool Options palette. If no vector layer exists, marking this check box creates one for the symmetric shape. If this check box is unmarked, the symmetric shape is placed on a raster layer. Placing a symmetric shape on a vector layer makes it easier to edit.

- 2 On the Materials palette, click the **Background and Fill properties** box, and choose a fill color.
- 3 Click the **Foreground and Stroke properties** box, and choose an outline color.
- 4 On the Tool Options palette, click one of the following buttons:

- **Draw Polygon** 

## • Draw Stellated

If you want to display the shape's nodes, mark the **Show Nodes** check box.

- 5 Type or set a value in the **Number of sides** control.
- 6 Drag to draw the shape.
- 7 Click the **Apply** button .

### You can also

---

Apply rounded outer corners to the shape	Mark the <b>Rounded Outer</b> check box.
--	--

---

Apply rounded inner corners to the stellated shape	Mark the <b>Rounded Inner</b> check box.
--	--

---

Set the radius for the stellated shape	Type or set a value in the <b>Radius</b> control.
--	---

---



You can save Tool Options palette settings as presets. For more information, see “Using and creating presets” on page 721.

You can also choose line style options such as style, stroke width, and join and miter limit settings. For more information, see “Drawing lines” on page 582.

## Creating preset shapes

You can draw preset shapes such as callouts, arrows, flowers, and gears.

### To draw a preset shape

Edit workspace

- 1 On the Tools toolbar, choose the **Preset Shape** tool .

**Note:** If you want to place the preset shape on the current vector layer, mark the **Create on Vector** check box on the Tool Options palette. If no vector layer exists, marking this check box creates one for the preset shape. If this check box is unmarked, the preset shape is placed on a raster layer. Placing a preset shape on a vector layer makes it easier to edit.

- 2 On the Tool Options palette, choose an option from the **Shapes List** drop-list.

If you want to filter the options, choose a category from the **Category** drop-list.

- 3 Drag to create the shape.

**Note:** If you want to apply a custom fill, unmark the **Retain style** check box. On the Materials palette, click the **Background and Fill properties** box, and choose a fill color. Click the **Foreground and Stroke properties** box, and choose an outline color. If you do not want the line segments to have a fill, click the **Transparent** button .

- 4 Drag to draw the shape.

### You can also

---

Choose a line style

Select an option from the **Line Style** drop-list.

---

Choose a stroke width (in pixels)

Type or set a value in the **Width** control.

---

## You can also

---

Smooth the appearance of a shape	Mark the <b>Anti-alias</b> check box.
Apply a join style	Choose an option from the <b>Join</b> drop-list. If you choose <b>Miter Join</b> , type or set a value in the <b>Miter limit</b> control to set the degree of pointedness. The higher the value, the more pointed the join is.
Create a shape with the same aspect ratio as the one in the <b>Shapes list</b>	Hold down <b>Shift</b> while you drag.
Place the centerpoint of the shape where you click	Right-click and drag.

---



You can save a Tool Options palette settings as presets. For more information, see “Using and creating presets” on page 721.

## Filling cutout shapes with images

You can use vector shapes, such as Preset Shapes, to create cutouts that are filled with the background imagery. The effect is similar to using a clipping mask, except the cutout object is created as a new file with a transparent background—perfect for collage, scrapbook, or other creative photo projects.



## To create a shape cutout

- 1 Open a copy of the image that you want to use as a fill.
- 2 On the Tools toolbar, choose one of the following tools:
  - Preset Shape
  - Rectangle
  - Ellipse
  - Symmetric Shape
- 3 On the Tool Options palette, set the options for your shape.
- 4 In the image window, drag where you want to create the shape.
- 5 Adjust the position of the shape.
- 6 On the Tool Options palette, click the **Shape Cutter** button .

The cutout is filled with the underlying imagery and is created as a new file with a transparent background. A layer and mask is also created on the current image.



To help determine the best size and position for the shape cutout, in the **Layers** palette, reduce the **Opacity** setting for the shape so that you can see the underlying image.

## Editing shapes

You can edit the basic properties of vector objects, such as the line width, line style, and anti-aliasing. You can also rename an object in the Layers palette. You can also hide or display vector objects.

### To modify vector object properties

Edit workspace

- 1 Select the vector object you want to edit.

If you want to edit multiple objects, choose the **Pick** tool , hold down **Shift**, and marquee select the objects.



- 2 On the Tool Options palette, click the **Properties** button .

The Vector Property dialog box appears.

- 3 Adjust any of the settings.
- 4 Click **OK**.

### To edit a shape by using the Tool Options palette

Edit workspace

- 1 On the Tools toolbar, select the **Pen** tool .
- 2 On the Tool Options palette, click **Edit Mode** button .
- 3 Click the shape you want to edit.
- 4 Adjust any of the available settings on the Tool Options palette.



Edit mode lets you edit shapes in a variety of ways; however, you can also edit shapes by using the **Pick** tool  to move, rotate, align, and stretch shapes.

## Saving shapes as presets

You can also save any vector object as a preset. Preset shapes are stored in shape libraries, in the ...Documents/Corel PaintShop Pro/17.0/Preset

Shapes folder. You can also store shape libraries in a different folder. For more information, see “Setting file locations” on page 691.

## To save a shape as a preset

Edit workspace

- 1 On the Tools toolbar, choose the **Pick** tool .
- 2 Select the shape you want to save as a preset.  
If you want to save multiple shapes, marquee select the shapes.
- 3 Choose **File ▶ Export ▶ Shape**.  
The Export Shape Library dialog box appears.
- 4 Type a name for the library file, and click **OK**.  
The library file is saved in the default **Preset Shapes** folder.

## To delete a shape library

Edit workspace

- 1 Choose a library file from the **Preset Shapes** folder.
- 2 Press **Delete**.

## Working with nodes

Nodes are square points on line and curve objects. You can change the shape of a line or curve object by dragging one or more of its nodes.

Nodes have zero, one, or two control arms. The length and direction of the control arms determine the shape of the contour at the node. The straight or curved line between two nodes is a line segment. There are four types of nodes: symmetrical, asymmetrical, cusp, and smooth.





*You can use symmetrical nodes to create smooth, flowing curves on either side of a node. Any adjustments to one control arm are mirrored by the other.*

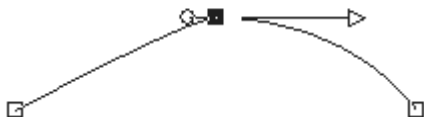

*You can use asymmetrical nodes to obtain a different amount of curve on each side of the node, but keep a smooth flow through the node. You can adjust the length of each control arm, but not the direction.*

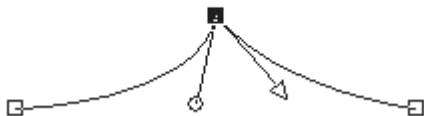

*You can use cusp nodes to create extreme changes in direction. You can adjust the length and direction of each control arm independently.*

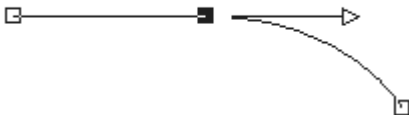

*You can use smooth nodes to create a smooth transition between straight and curved line segments.*



You can select a node to edit, or you can move it. Moving a node alters the shape of a vector object. If an object has more than one contour, you can move all of its nodes. You can also move the path to move the entire object. You can edit the contour of a vector object by adding, merging, or deleting nodes anywhere along a path.

You can merge nodes on a contour while retaining the line segments on each side. The line segments are combined into one line segment between remaining nodes. If the contour is curved at the node, Corel PaintShop Pro attempts to retain the curve.

You can also delete a node to remove the node and the line segments on each side.

## To select a node

Edit workspace

- 1 On the Tools toolbar, select the **Pen** tool .
- 2 On the Tool Options palette, click **Edit Mode** button .
- 3 Click a vector object.  
The object's nodes appear.
- 4 Click the node.  
The selected node appears with a solid gray fill.

## You can also

Select multiple nodes	Hold down <b>Shift</b> , and click the nodes.
Select all nodes on a contour	Double-click one node. If the object has only one contour, this selects all nodes in the path.
Select all nodes in a path (all nodes in the object)	Right-click a node, and choose <b>Edit ▶ Select All</b> .
Select the next or previous node on a contour	Hold down <b>Shift</b> , and press [ or ].
Deselect a selected node	Hold down <b>Shift</b> , and click the node.





To view the selected node more easily, click the **Visibility** icon  on the Layers palette next to the vector object you are working on. This hides the fill and outline for the object. For more information about showing and hiding layers, see “Viewing layers” on page 344.



Start and end nodes are easy to find. The cursor displays “START” or “END” when you hold it over the node. If the shape is closed, the cursor displays “CLOSE.”

## To move a node

### Edit workspace



- 1 On the Tools toolbar, select the **Pen** tool .
- 2 On the Tool Options palette, click **Edit Mode** button .
- 3 Select a node, and then drag it to a new position.



You can constrain a node's line segments to 45-degree increments by holding down **Shift** as you drag.



## To add a node on a contour

Edit workspace

- 1 On the Tools toolbar, select the **Pen** tool .
- 2 On the Tool Options palette, click one of the following buttons:
  - **Edit Mode** 
  - **Knife Mode** 
- 3 Click the contour.
- 4 Hold down **Ctrl**, and click where you want to add a node.  
The cursor displays "+ADD."

## To add a new start or end node

Edit workspace

- 1 On the Tools toolbar, select the **Pen** tool .
- 2 On the Tool Options palette, click the **Drawing Lines and Polylines** button .
- 3 Select the start or end node of the contour.
- 4 Click to add another node.  
The contour automatically connects to the new node.



## To merge one or more nodes

Edit workspace

- 1 On the Tools toolbar, select the **Pen** tool .
- 2 Select the node you want to merge.  
If you want to select multiple nodes, hold down **Shift** and click.
- 3 Right-click a node, and choose **Edit ▶ Merge**.

## To transform nodes

Edit workspace

- 1 On the Tools toolbar, select the **Pen** tool .
- 2 On the Tool Options palette, click the **Edit Mode** button .  
**Note:** If you cannot see all of the options on the Tool Options palette, click the **More** button .
- 3 Select one or more nodes.
- 4 Choose **Objects** ▶ **Transform Selected Nodes**, and choose one of the following commands:
  - **Flip** — moves selected nodes along the vertical axis (those on top go to the bottom and vice versa). On a single node, the command flips the node's control arms.
  - **Mirror** — moves selected nodes along the horizontal axis (those on the left go to the right and vice versa). On a single node, the command mirrors the node's control arms.
  - **Rotate** — rotates the selected nodes by the current rotation setting. Applied to a single node, the control arms (if any) will rotate.
  - **Skew X** — moves selected nodes to the left or right (along the horizontal axis) using the current skew setting
  - **Skew Y** — moves selected nodes to the left or right (along the vertical axis) using the current skew setting
  - **Contract** — moves the selected nodes closer to each other by the current contraction setting. This command cannot be applied to a single node.
  - **Expand** — moves the selected nodes away from each other by the current expansion setting. This command cannot be applied to a single node.
- 5 Where applicable, type a value for the selected transformation setting.

- 6 Click the **Apply** button .

## To adjust a curve using a node's control arms

Edit workspace

- 1 Select a node to display its control arms.  
**Note:** Cusp nodes may have no control arms.
- 2 Move the cursor over a control handle until the cursor changes to two rotating arrows.
- 3 Drag the handle.



To constrain the control arms to fixed angles (45-degree increments), hold down **Shift** as you drag.

## To straighten a curve between two nodes

Edit workspace

- 1 Select two consecutive nodes.
- 2 Right-click one node, and then choose **Node Type ▶ Convert to Line**.

## To delete a node

Edit workspace

- 1 Select a node.
- 2 Press **Delete**.



If you delete a node in the middle of an open contour, the vector object becomes two separate contours. If you delete a node in a closed contour, the contour opens.

## Sizing, shaping, and rotating vector objects

You can transform vector objects and vector text interactively. For example, you can drag the handles on a bounding box to size, shape, or rotate objects. You can also transform vector objects by editing their nodes. For more information, see “Working with nodes” on page 564.

You can also size vector object to make them the same width, height, or both.

### To size and shape a vector object

Edit workspace

- 1 On the Tools toolbar, choose the **Pick** tool .
- 2 Select the object.
- 3 Perform any of the steps in the following table.

To	Do the following
Size a vector object	Drag a corner or edge handle. If you want to resize while changing the current proportions, right-click and drag a handle.
Change perspective symmetrically	Hold down <b>Shift</b> , and drag a corner handle.
Shear a vector object	Hold down <b>Shift</b> , and drag a side handle.
Distort a vector object	Hold down <b>Ctrl + Shift</b> , and drag a handle.

### To rotate vector objects

Edit workspace

- 1 On the Tools toolbar, choose the **Pick** tool .
- 2 Select an object.





- 3 Drag the rotation handle.



To change the center of rotation, hold down **Ctrl**, and drag the rotation pivot point to a new location.

## To make vector objects the same size

Edit workspace

- 1 On the Tools toolbar, choose the **Pick** tool .
- 2 Select the first vector object.  
**Note:** The first object controls how all the other vector objects are resized.
- 3 Hold down **Shift**, and click the other objects you want to resize.
- 4 On the Tool Options palette, choose one of the following options from the Same Size group box:
  - **Make Same Height** 
  - **Make Same Width** 
  - **Make Same Width and Height** 



To change the object's proportions while resizing, select the object with the **Pick** tool , and then right-click and drag a corner handle.

## Aligning, distributing, and arranging vector objects

You can align, distribute, and arrange vector objects on the canvas. For example, you can align their edges, distribute them evenly, center them on the image canvas, or arrange their order (from top to bottom) on a layer. Each object you draw on a layer is stacked on top of the next.



## To move a vector object

Edit workspace

- 1 On the Tools toolbar, choose the **Pick** tool .
- 2 Select the object.  
If you want to move multiple objects, hold down **Shift** and select the objects.  
A bounding box surrounds the selected objects.
- 3 Drag the object or objects to a new position.

### You can also





---



Move an object one pixel at a time	Press an arrow key.
Move an object 10 pixels at a time	Hold down <b>Ctrl</b> , and press an arrow key.
Move an object 50 pixels at a time	Hold down <b>Shift</b> , and press an arrow key.
Move an object 100 pixels at a time	Hold down <b>Shift + Ctrl</b> , and press an arrow key.

---

## To align vector objects

Edit workspace

- 1 On the Tools toolbar, choose the **Pick** tool .
- 2 Select the first vector object.
- 3 Hold down **Shift**, and select the other objects you want to align.
- 4 In the Tool Options palette, click one of the following buttons in the **Object Alignment** group box:
  - **Align Top** 
  - **Align Bottom** 
  - **Align Left** 
  - **Align Right** 







- Align Vertical Center 
- Align Horizontal Center 



To move an object, select it on the Layers palette, and drag it up or down in the list.

## To evenly distribute objects

Edit workspace



- 1 On the Tools toolbar, choose the **Pick** tool .
- 2 Hold down **Shift**, and marquee select the objects.  
**Note:** You must have three or more objects selected to distribute them in relation to each other.
- 3 In Tool Options palette, click one of the following buttons in the Object Distribution group box:
  - Distribute Vertical Top 
  - Distribute Vertical Center 
  - Distribute Vertical Bottom 
  - Distribute Horizontal Right 
  - Distribute Horizontal Center 
  - Distribute Horizontal Left 

## To align vector objects to the canvas

Edit workspace

- 1 On the Tools toolbar, choose the **Pick** tool .
- 2 Select an object.

If you want to align multiple objects, hold down **Shift** and marquee select the objects.



- 3 In the Tool Options palette, click one of the following buttons in the Position On Canvas group box:
  - Center in Canvas 
  - Align Horizontally Center in Canvas 
  - Align Vertically Center in Canvas 

## To distribute vector objects on the canvas

Edit workspace

- 1 On the Tools toolbar, choose the **Pick** tool .
- 2 Select an object.

If you want to distribute multiple objects, marquee select the objects.

- 3 In the Tool Options palette, click one of the following buttons in the Position On Canvas group box:
  - Space Evenly Horizontal 
  - Space Evenly Vertical 

## To arrange vector objects

Edit workspace

- 1 On the Tools toolbar, choose the **Pick** tool .
- 2 Select an object.
- 3 Right-click the object, choose **Arrange**, and select one of the following options:
  - **Bring to Top** — moves an object to the top
  - **Send to Bottom** — moves an object to the bottom
  - **Move Up** — moves an object up one position
  - **Move Down** — moves an object down one position



You can also arrange vector objects by dragging them up or down in the Layer palette.





## Grouping and ungrouping vector objects

You can group several objects or groups of objects to move, resize, reshape, and change their lines and materials.

When you group objects on different layers, Corel PaintShop Pro automatically moves them to the layer of the first object you select. Each group is labeled on the Layers palette and the objects in the group are shown as components.

### To group or ungroup vector objects

Edit workspace

To	Do the following
Group objects	Using the <b>Pick</b> tool  , select the objects you want to group. On the Tool Options palette, click the <b>Group</b> button  .
Ungroup objects	Using the <b>Pick</b> tool  , select the group. On the Tool Options palette, click the <b>Ungroup</b> button  .

### To group objects by using the Layers palette

Edit workspace

- 1 On the Layers palette, click the first object you want to group.
- 2 Hold down **Shift**, and click each object you want to add to the group.
- 3 Right-click, and choose **Group**.



If you group objects from several layers, Corel PaintShop Pro moves them to the layer of the first object you selected.



Click the plus sign (+) next to the group name to show the group's components.

## To remove an object from a group

Edit workspace

- On the Layers palette, drag the object to another group or layer.

## Converting objects to paths

You can convert any selected vector object, including text, to a fully editable path (as though it were created by the Pen tool). This allows you to use the Pen tool's full complement of node-editing commands to modify the converted object.

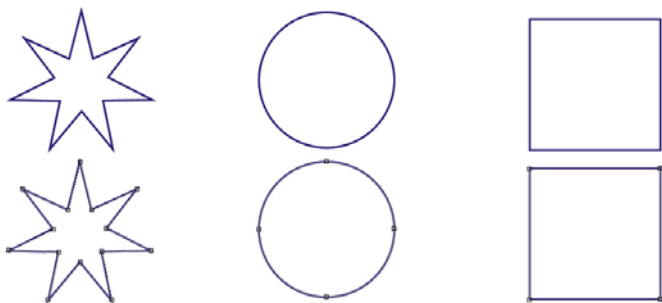

*This example shows graphics Converted to paths.*

## To convert a vector object to an editable path

Edit workspace

- 1 On the Tools toolbar, choose the **Pick tool** .





- 2 Select an object.  
If you want to convert multiple objects to paths, marquee select the objects.
- 3 Right-click the objects, and choose **Convert to Path**.

## Adding and closing contours

You can add new contours to any existing object. The new contour will have the same properties, including color, material, line style, and so on, as the selected object. You can also duplicate contours.



### To add a contour to an object

Edit workspace

- 1 On the Tools toolbar, click the **Pen** tool .
- 2 In the Tool Options palette, click the **Edit Mode** button .
- 3 Select an object.
- 4 Click one of the following buttons:
  - **Draw Lines and Polylines** 
  - **Draw Point-to-point Bézier Curves** 
  - **Draw Freehand** 
- 5 Drag on the object to create the contour.

### To close a contour

Edit workspace

- 1 On the Tools toolbar, select the **Pen** tool .
- 2 On the Tool Options palette, click the **Edit Mode** button .
- 3 Select a contour.
- 4 Click the **Close selected open contours** button .



When you close a contour, Corel PaintShop Pro draws a segment from the contour's start node to its end node.

## Editing contours and paths



You can edit the contours and paths of vector objects. You can join contours by connecting their end points. You can also reverse the direction of paths and contours. The direction of a contour flows from the start node to the end node. When you place the cursor over the start node, a "START" message appears next to the cursor. When you place the cursor over the end node, an "END" message appears. If the object has a closed path, a "CLOSE" message appears.

You can duplicate contours.

For more information about the different types of nodes, see "Modifying lines and curves" on page 589.

### To join two contours

Edit workspace



- 1 On the Tools toolbar, select the **Pen** tool .
- 2 On the Tool Options palette, click the **Edit Mode** button .
- 3 Select one of the contours you want to join.  
All of the nodes in the object are displayed.
- 4 Select the start or end node of the first contour you want to join.  
**Note:** You can only join contours in the same object.
- 5 Hold down **Shift**, and select the start or end node of the second contour.
- 6 Right-click, and choose **Edit ▶ Join**.



You can also join contours manually. Drag a node on the first contour over the second contour's start or end node. When the cursor displays "JOIN," release the mouse button.

## To break a contour at a node

Edit workspace



- 1 On the Tools toolbar, select the **Pen** tool .
- 2 On the Tool Options palette, click the **Edit Mode** button .
- 3 Select the node where you want to break the contour.
- 4 Right-click the node, and choose **Edit ▶ Break**.



The path or contour breaks and a new node is added on top of the current node. The node square changes to a node-on-node indicator .



## To move a path

Edit workspace

- 1 On the Tools toolbar, select the **Pen** tool .
- 2 On the Tool Options palette, click the **Edit Mode** button .
- 3 Drag any contour in the path.

## To move a contour

Edit workspace

- 1 On the Tools toolbar, select the **Pen** tool .
- 2 On the Tool Options palette, click the **Edit Mode** button .
- 3 Hold down **Shift**, and move the cursor over the contour until the cursor displays "SUB."
- 4 Drag the contour.







You can also move a contour by double-clicking a node to select all nodes, and then dragging one of the nodes.

## To reverse a path or contour

Edit workspace



- 1 On the Tools toolbar, select the **Pen** tool .
- 2 On the Tool Options palette, click the **Edit Mode** button .
- 3 Click on a contour or path.
- 4 Select a node.

If you want to reverse multiple contours, select one node from each contour.

- 5 Right-click the path or contour, choose **Edit**, and then choose one of the following:
  - **Reverse Path**
  - **Reverse Contour**

## To duplicate a contour

Edit workspace



- 1 On the Tools toolbar, select the **Pen** tool .
- 2 On the Tool Options palette, click the **Edit Mode** button .
- 3 Select one or more nodes.
- 4 Choose **Objects** ▶ **Edit**, and select one of the following options:
  - **Duplicate** — copies the selected contour and pastes it directly on top of the original contour
  - **Duplicate & Offset** — copies the selected contour and pastes it at an offset from the original contour. The default offset is 10 pixels in the X and Y directions.



You can adjust the offset from the original contour by adjusting the settings in the **Duplication X** and **Duplication Y** controls on the Tool Options palette.

## To delete a contour

Edit workspace

- 1 On the Tools toolbar, select the **Pen** tool .
- 2 In the Tool Options palette, click the **Edit Mode** button .
- 3 Click on a contour.
- 4 Double-click one node to select all nodes.
- 5 Press **Delete**.



You cannot delete a path. A path is deleted with its object or when all of its contours are deleted.

## Drawing lines

You can draw straight lines, freeform lines, and line segments. You can edit the nodes in a line to create curves.



You can also adjust the line options of existing vector objects.

## To draw a line segment

Edit workspace

- 1 On the Tools toolbar, choose the **Pen** tool .

**Note:** If you want to place the line segment on the current vector layer, mark the **Create on Vector** check box on the Tool Options palette. If no vector layer exists, marking this check box creates one for the line segment. If this check box is unmarked, the line segment is placed on a raster layer. Placing a line segment on a vector layer makes it easier to edit.

- 2 On the Materials palette, click the **Foreground and Stroke properties** box, and choose a color for the outline.
  - 3 If you are drawing connected line segments and you want to apply a fill, click the **Background and Fill properties** box, and choose a color for the text fill. If you do not want the line segments to have a fill, click the **Transparent** button .
- Note:** If you are drawing a single, unconnected line segment, it is not necessary to choose settings from the **Background and Fill properties** box.
- 4 On the Tool Options palette, click the **Draw Lines and Polylines** button .
  - 5 Choose a line style from the **Line Style** drop-list.
  - 6 Type or set a line width (in pixels) value in the **Width** control.
  - 7 Drag in the image window to create the line.
  - 8 On the Tool Options palette, click the **Apply** button .

## You can also



View the object's nodes while drawing	Mark the <b>Show Nodes</b> check box.
Smooth the appearance of the line	Mark the <b>Anti-alias</b> check box.
Choose a join setting	Select an option from the <b>Join</b> drop-list. If you select <b>Miter Join</b> , you can type or set a value in the <b>Miter limit</b> control to set the degree of pointedness.
Create a vertical, horizontal, or 45-degree line	Hold down <b>Shift</b> while dragging.
Connect each line segment	Mark the <b>Connect Segments</b> check box.



You can save your settings in the Tool Options palette settings for subsequent use. For more information about saving settings as presets, see “Using and creating presets” on page 721.

## To draw a curved or straight line



Edit workspace

- 1 On the Tools toolbar, choose the **Pen** tool .
- 2 On the Tool Options palette, click the **Draw Point to Point** button .
- 3 Drag in the image window to create the line.
- 4 Do one of the following:
  - To create a straight line, click where you want the next node.
  - To create a curved line, click and drag. When the curve is the right shape, release the mouse button.

If you want to draw lines at fixed angles (45 degree increments), hold down **Shift** as you drag.



## To draw a free-form line

Edit workspace

- 1 On the Tools toolbar, choose the **Pen** tool .
- 2 On the Tool Options palette, click the **Draw Freehand** button .
- 3 Drag in the image window to create the line.

## To draw line segments

Edit workspace







- 1 On the Tools toolbar, choose the **Pen** tool .
- 2 On the Tool Options palette, click the **Draw Line and Polylines** button .
- 3 Drag in the image window to create the line.

## Saving custom line styles

You can design your own line styles and save them as presets.

### To design and save a custom line style



Edit workspace

- 1 On the Tools toolbar, choose one of the following tools:
  - Pen tool 
  - Rectangle tool 
  - Ellipse tool 
  - Symmetric Shape tool 
  - Preset Shape tool 
  - Text tool 
- 2 On the Tool Options palette, click the **Line Style** drop-list, and click **Custom**.

If you want to copy an existing line style, choose that style from the **Line Style** drop-list, and click **Custom**.

- 3 In the Styled Line Editor dialog box, choose settings from any of the following controls:
  - **First cap** — lets you pick a style for the first segment in the line
  - **Last cap** — lets you pick a style for the last segment in the lineIf you want to specify a size for the cap, click the **Size** button, and type or set a value in the **Width** and **Height** controls. To make the height and width equal, mark the **Link axes** check box.
- 4 Do one of the following:
  - If you are creating a new line, click **Save as New**. Type a name in the **Styled Line Name** field, and click **OK**.
  - If you are editing an existing line, click **Save**.

## You can also

Undo the changes	Click the <b>Undo</b> button  .
Reset the line to the original style	Click the <b>Reset</b> button  .
Create separate end caps for the middle dashes in the line	Mark the <b>Different segment caps</b> check box, and choose settings from the <b>Segment Start</b> and <b>Segment End</b> group boxes.
Add dashes or gaps	Type or set a value in the <b>Length</b> control, and click <b>Add</b> .
Delete dashes or gaps	Select a dash or gap, and click <b>Delete</b> .
Remove all dashes and gaps	Click <b>Clear</b> .



The preview area at the bottom of the Styled Lines Editor dialog box displays the changes you make to the line. The edit area has a ruler you can use to size dashes and gaps (in pixels).

Saved styles appear in the **Line Style** drop-list on the Tool Options palette.

## Drawing curves

You can draw Bézier and freehand curves.

### To draw an object with Bézier curves

Edit workspace

- 1 On the Tools toolbar, choose the **Pen** tool .

**Note:** If you want to place the line segment on the current vector layer, mark the **Create on Vector** check box on the Tool Options palette. If no vector layer exists, marking this check box creates one for the line segment. If this check box is unmarked, the line

segment is placed on a raster layer. Placing a line segment on a vector layer makes it easier to edit.

- 2 On the Materials palette, click the **Foreground and Stroke properties** box, and choose a color for the outline.

If you want to apply a fill to the curve, click the **Background and Fill properties** box, and choose a color. If you do not want to apply a fill to the curve, click the **Transparent** button .

- 3 In the Tool Options palette, click the **Draw Point to Point** button .

- 4 Mark the **Show Nodes** check box.

- 5 Click where you want to place the first node, and drag.



As you drag, the arrow-end of the control arm handle points in the same direction. Release the mouse button when the first control arm reaches the desired length.

- 6 Click where you want to place the second node, and drag.

As you drag, the curve segment appears on the image canvas.

**Note:** If you marked the **Connect Segments** option, you can continue adding segments in this manner.

- 7 On the Tool Options palette, click one of the following buttons to complete the Bézier curve object:

- **Start New Contour** button  — creates an open shape where the first and last segments are not connected
- **Close Selected Open Contours** button  — creates a closed shape where the first and last segments are connected

- 8 Click the **Apply** button .

## You can also

---

Automatically connect each curve segment

Mark the **Connect Segments** check box.

---

## You can also

Choose a line style	Choose an option from the <b>Line Style</b> drop-list.
Set a line width	Type or set a value in the <b>Width</b> control.
Smooth the line's edges	Mark the <b>Anti-alias</b> check box.



You can save Tool Options palette settings as presets. For more information, see “Using and creating presets” on page 721.

## To draw a freehand curve

Edit workspace

- 1 On the Tools toolbar, choose the **Pen** tool .

**Note:** If you want to place the line segment on the current vector layer, mark the **Create on Vector** check box on the Tool Options palette. If no vector layer exists, marking this check box creates one for the line segment. If this check box is unmarked, the line segment is placed on a raster layer. Placing a line segment on a vector layer makes it easier to edit.

- 2 On the Materials palette, click the **Foreground and Stroke properties** box, and choose a color for the outline.

If you want to apply a fill to the curve, click the **Background and Fill properties** box, and choose a color. If you do not want the curve to have a fill, click the **Transparent** button .

- 3 On the Tool Options palette, click the **Draw Freehand** button .

If you want to display the curve's nodes, mark the **Show Nodes** check box.

- 4 Type or set a value in the **Tracking** control to set the distance in pixels between nodes.



Higher values create smoother, less precise lines with fewer nodes; lower values create more segmented, precise lines with more nodes.

- 5 Drag to create the curve.
- 6 Click the **Apply** button .

## You can also

Connect multiple curve objects	Mark the <b>Connect Segments</b> check box.
Smooth the curve's edges	Mark the <b>Anti-alias</b> check box.
Choose a join setting	Select an option from the <b>Join</b> drop-list. If you selected <b>Miter Join</b> , you can type or set a value in the <b>Miter limit</b> control to set the degree of pointedness.
Choose a line style	Choose an option from the <b>Line style</b> drop-list.
Set a line width	Type or set a value in the <b>Width</b> control.

## Modifying lines and curves

You can edit the properties of lines and curves. You can reshape a curve by changing its nodes the shape of the contour at a node by changing the node type, by modifying its line segments on either side of a node, or by connecting line segments. You can also cut a line segment. When you cut a closed path or contour, you open it. When you cut an open path or contour, you create two separate contours.

## To edit a line or curve

Edit workspace

- 1 On the Tools toolbar, choose the **Pen** tool .



- 2 On the Tool Options palette, click the **Edit Mode** button .
- 3 Select the shape.
- 4 Modify any of the settings on the Tool Options palette.



You can also edit the curve by clicking the **Pick** tool , selecting the curve, and modifying any of the settings on the Tool Options palette.



## To adjust a line segment by changing the nodes

Edit workspace

- 1 On the Tools toolbar, choose the **Pen** tool .
- 2 On the Tool Options palette, click the **Edit Mode** button .
- 3 Right-click a node, choose **Node Type**, and select one of the following options:
  - **Convert to Line** — straightens the segment before and after the node
  - **Line Before** — straightens the segment before the node
  - **Line After** — straightens the segment after the node
  - **Curve Before** — curves the segment before the node
  - **Curve After** — curves the segment after the node

## To connect multiple line segments

Edit workspace

- 1 Create as many connected line segments as you want.
- 2 On the Tool Options palette, click one of the following buttons:
  - **Start New Contour**  — connects line segments in an open shape
  - **Close Selected Open Contours**  — connects line segments in a closed shape



- 3 Click the **Apply** button .



You can save a set of Tool Options palette settings as presets. For more information, see “Using and creating presets” on page 721.

## To cut a line segment

Edit workspace

- 1 From the Tools toolbar, choose the **Pen** tool .
- 2 On the Tool Options palette, click the **Knife Mode** button .
- 3 Drag across the contour where you want to cut it.





When you click the **Knife Mode** button, you can cut through all selected contours in an object.

## Copying and moving vector objects

You can copy and move vector objects by using Cut, Copy, and Paste commands. For more information about moving objects precisely, see “To move a vector object” on page 573.

## To copy or move a vector object

Edit workspace

- 1 On the Tools toolbar, select the **Pen** tool .
- 2 On the Tool Options palette, click the **Edit Mode** button .
- 3 Click on a contour, and then double-click one node to select all nodes.
- 4 Choose **Objects** ▶ **Edit** and select one of the following commands:
  - **Copy** — copies the selected contour to the Windows clipboard

- **Cut** — removes the selected contour to the Windows clipboard. If the object has only one contour, the command removes the entire object.
- 5 Click where you want to copy or move the contour.
  - 6 Choose **Edit** and choose one of the following options:
    - **Paste As New Vector Selection** — pastes vector objects within the same layer
    - **Paste As New Layer** — pastes vector objects as a new layer
    - **Paste As New Image** — pastes vector objects as a new image



Brush tools offer countless ways to work creatively with your images. For example, you can apply soft- or hard-edged brushstrokes of any color or material, paint with another image as a source, retouch images to correct colors or contrast, replace colors, or paint with picture tubes. You can also erase pixels by making them transparent.

Brush tools work only on raster layers, and they produce the best results when applied to grayscale or 16 million–color images. They are less effective when applied to images of other color depths.

You can also work with painting tools within a selection so that only the selected pixels are affected. For more information about making selections, see “Working with selections” on page 291.

This section presents the following topics:

- Choosing brushes
- Choosing brush options
- Using brushes
- Customizing brush settings
- Creating brush tips and presets
- Importing and sharing brush tips

## Choosing brushes

You can choose from the following brush tools:

- **Paint Brush** — creates strokes of color that simulate strokes from an artist’s paintbrush. Brushstrokes can have hard or soft edges. The Paint Brush is a multipurpose tool that can be used to edit an image by applying color to areas as small as a single pixel. This tool can be used to adjust transparency in specific areas or to create a selection. For more information, see “To create a selection by using a Painting tool” on page 301.
- **Airbrush** — simulates an airbrush or spray can. The longer you apply the brush to an area, the more pronounced the effect becomes.
- **Warp Brush** — produces a warping effect on image pixels. You can twirl areas of the image, contract or expand parts of the image, and create other interesting effects. For more information, see “Warping images” on page 525.
- **Picture Tube** — lets you paint with a collection of preset objects. For example, you can add butterflies and beetles to a picnic setting, fill an aquarium with fish, or frame a picture with holly. You can use the picture tubes included with Corel PaintShop Pro or create your own. For more information, see “Using the Picture Tube tool” on page 519.
- **Eraser** — causes pixels to become transparent. For more information, see “Erasing image areas” on page 244.
- **Background Eraser** — erases pixels selectively. For more information, see “Erasing image areas” on page 244.
- **Clone Brush** — lets you edit your image by using parts of the image, or parts of another image, as a paint source. For more information, see “Removing flaws and objects” on page 240.

- **Color Replacer** — replaces a color in a selection or layer with another color. For more information, see “Replacing colors, gradients, or patterns” on page 258.
- **Retouch Brushes** — let you retouch images. Some retouch brushes mimic photographic effects. Others change pixels based on lightness, saturation, hue, or color values. Some retouch brushes are similar to color correction commands in the effects they produce.

## Choosing brush options

The brush options help you create hundreds of different brushstrokes. You can experiment with the options until you achieve the effect you want.

You can further customize the basic brush settings by specifying additional options on the Brush Variance palette. For more information about using the Brush Variance palette, see “Customizing brush settings” on page 600.

The following options are available on the Tool Options palette for painting tools:

- **Shape** — specifies the shape of the brush tip. You can create a rectangular, elliptical, or angled brush tip by starting with the round or square shape and modifying it with the Thickness and Rotation options.
- **Size** — determines the size of the brush in pixels. You can adjust the Size value by using the keyboard as well as by setting the Size control in the Tool Options palette. For more information, see “To adjust the brush size by using the keyboard” on page 616.

- **Hardness** — determines the sharpness of the brush edges. A setting of 100 produces the sharpest edge; lower values produce an increasingly softer, fading edge.
- **Step** — determines the time interval that elapses between applications of paint, with each application defined as a single, continuous brushstroke. Lower values produce a smoother, more continuous appearance; higher values create a choppier appearance.
- **Density** — determines the evenness of coverage produced by the brushstroke (or for the Eraser tool, the evenness of the erasure). Higher values produce more even coverage; lower values produce spottier coverage, which resembles a spray-painted effect. When using the Airbrush tool, you should set Density to values lower than 100.
- **Thickness** — determines the width of the brushstroke. A setting of 100 produces a brush tip that is completely round or completely square, depending on the Shape setting. As the Thickness setting decreases, the brush becomes increasingly narrow.
- **Rotation** — applies rotation to a noncircular brush tip
- **Opacity** — determines how well the paint covers the image surface. At 100% opacity, the painted brushstroke completely covers the surface beneath it. At 1% opacity, the paint stroke is almost completely transparent. For the Eraser tool, this setting determines the level of erasing, so that a setting of 100% produces the most transparent result.
- **Blend mode** — determines how painted pixels are blended with pixels on underlying layers. The blend modes are the same as layer blend modes. With the Paint Behind blend mode, for example, painting is done behind the image on the active layer. No paint is visible when the topmost layer and the active layer are both fully



opaque. For more information about blend modes, see “Blending layers” on page 350.

- **Rate** — determines the rate at which the Airbrush tool applies paint (from 0 to 50). A value of 0 applies a consistent amount of paint even when the speed of the brushstroke varies. Higher values apply more paint when the brush slows down or pauses.
- **Stroke** — lets you build up paint on existing paint strokes that were applied with the Continuous check box marked. If the Continuous check box is not marked, or if the check box is marked but no strokes have been made, the Stroke button is grayed (unavailable).
- **Continuous** — specifies whether paint builds up when multiple brushstrokes are applied over the same area with opacity set at less than 100%. If this check box is marked, painting produces a continuous color, and repainting an area has no effect. To repaint an area, you must click the Stroke button. If the Continuous check box is unmarked (the default), each brushstroke over the same area applies more paint; the color darkens until it reaches 100% opacity.
- **Wet Look Paint** — mimics wet paint, with soft color inside and a darker ring near the edge. The effect is more visible with lower values for the Hardness setting.
- **Smart Edge** — uses content-aware technology to sample the brush stroke area and apply a brush stroke only to areas that match the underlying pixels. This makes it easier to apply brush strokes to or around specific elements in your image. For example, you can use Smart Edge with retouch brushes, such as the Dodge, Burn, or Sharpen, to help you edit specific areas of the face, lips, or eyes. Note: Enabling Smart Edge can affect the brush speed.

## Using brushes

When you choose a brush, you can modify its settings to achieve the effect you want. You can also reset the brush to its default settings.

When applying paint, you can undo and redo multiple brushstrokes.

### To use a brush

Edit workspace

- 1 On the Tools toolbar, choose a brush tool.
- 2 On the Materials palette, choose the foreground and background colors and materials.
- 3 On the Tool Options palette, choose a tool from the **Presets** drop-list.
- 4 Choose a preset brush tip from the brush tip drop-list .
- 5 Specify the brush options, such as shape, size, opacity, hardness, thickness, and rotation.
- 6 Do one of the following:
  - To apply the foreground color or material, drag in the image.
  - To apply the background color or material, hold down the right mouse button, and drag in the image.



With the Airbrush tool, you can build up color in one area by clicking and holding the mouse at one position.

To paint a straight line, click once at the beginning point, press **Shift**, and then click the end point. To continue the straight line, move to the next point, press **Shift**, and then click again.

### To reset a brush to its default settings

Edit workspace

- 1 On the Tool Options palette, click the **Presets** drop-list.

- 2 Click the **Reset to Default** button .

## To undo the most recent brushstroke

Edit workspace

- Click the **Undo** button  on the Standard toolbar.



You can also press **Ctrl + Z** or use the History palette to undo the stroke.

## To undo multiple brushstrokes

Edit workspace

- Click the **Undo** button  on the Standard toolbar multiple times.



You can also press **Ctrl + Z** multiple times or use the History palette to undo multiple strokes.

You can redo strokes by clicking the **Redo** button  on the Standard toolbar, by pressing **Ctrl + Alt + Z**, or by using the History palette.

## Customizing brush settings

The Brush Variance palette lets you customize the settings in the Tool Options palette for particular brush options. You can also make random adjustments by increasing the Jitter percentage.

You may find the most benefit to using Brush Variance palette settings if you use a pen tablet or a 4D mouse.

### To customize brush settings

Edit workspace

- 1 Choose **View ▶ Palettes ▶ Brush Variance**.
- 2 On the Tools toolbar, choose a brush tool.
- 3 On the Tool Options palette, set the brush options.
- 4 On the Brush Variance palette, set the brush variance for each option (Color Blend, Hue, Saturation, Lightness, Size, Opacity, Thickness, Rotation, Density):
  - **Normal** — applies no variance
  - **Pressure** — applies variance to the selected brush attribute according to the pressure from a tablet stylus
  - **Tilt Angle** — applies variance based on the angle between the tablet stylus and the tablet
  - **Tilt Direction** — applies variance based on the rotation angle of the brush tip
  - **Orientation** — applies variance based on the rotation angle around the stylus (for 4D mouse only)
  - **Fingerwheel** — lets you control the variance in the brush attribute by using the wheel on an airbrush stylus
  - **Z-Wheel** — lets you control the brush attribute by using a 4D mouse wheel that is set to behave according to the current application

- **Direction** — controls brush variation based on the angle between consecutive mouse points on a path
- **Fade In** — fades the brush impression from small to large
- **Repeating Fade In** — repeatedly fades the brush impression from small to large
- **Fade Out** — fades the brush impression from large to small
- **Oscillating Fade** — repeatedly fades the brush impression in and out by oscillating between small and large

**Note:** Options marked with an asterisk (\*) in the Brush Variance palette are available only to users with pressure-sensitive tablets. The options available depend on the type of tablet being used.

- 5 Type or set a value in the **Fade rate (pixels)** control to select a threshold for the number of pixels over which the fading in and fading out occurs.

Lower values produce faster fading; higher values produce slower fading.

- 6 Type or set a value in the **Position Jitter (%)** control to select a percentage for randomly adjusting the brush impression location. Mark the **Scale** check box if you want the jitter to scale proportionally when you change the brush size.
- 7 Type or set a value in the **Impressions per step** control to indicate how many brush impressions per step are made of the brushstroke



To reset brush variance options to their default values, click the **Reset Brush Variance palette** button .

If you have a variance loaded with a brush and then load another brush without loading its variance, the new brush can take on the variance settings from the previous brush. Click the **Reset Brush Variance palette** button  to clear any leftover variance settings.

You can save your modified brush as a brush tip or as a preset. For more information about saving brushes and presets, see “Creating brush tips and presets” on page 602.

## Creating brush tips and presets



By modifying the brush options, you can create your own brush tips to use with the painting tools. When you create a brush tip, all options selected for the brush are saved, including the brush shape, step, density, thickness, size, hardness, and rotation settings. You can also include the variance settings in creating a brush tip. The settings that you save can be applied to any tool that has a brush tip control in the Tool Options palette.

You can also make a selection, and then use the selection to create a custom brush with a width and height of up to 999 × 999 pixels.

In addition to brush tips, you can create brush presets. When you create a preset, all settings specified for a particular tool are saved, including all of the parameters and variance settings. The tool preset is available only when you select that particular tool.

### To create a brush tip

*Edit workspace*

- 1 On the Tools toolbar, choose a painting tool.
- 2 On the Tool Options palette, modify the settings for the brush.
- 3 Click the brush tip drop-list  to display current brush tips.
- 4 Click the **Create Brush Tip** button  in the brush tip drop-list.
- 5 Complete the fields in the Create Brush Tip dialog box.
- 6 Click **OK**.

The new brush appears in the brush tip drop-list. You can use the new brush with any of the painting tools that display this drop-list.





You can also open the Create Brush Tip dialog box by choosing **File ▶ Export ▶ Custom Brush**.

To save the new brush in a folder other than the default Brushes folder, click **Edit Paths** in the Create Brush Tip dialog box. For more information on changing file locations, see “Setting file locations” on page 691.

## To create a brush tip from a selection

Edit workspace

- 1 Make a selection of the area you want to convert into a custom brush.
- 2 On the Tools toolbar, choose a painting tool.
- 3 On the Tool Options palette, click the brush tip drop-list  to display current brush tips.
- 4 Click the **Create Brush Tip from Selection** button .

A preview of the new brush appears in the Create Brush Tip dialog box.

- 5 Enter a name for the brush in the **Name** box.
- 6 Select a step value.
- 7 Click **OK**.

The new brush appears in the brush tip drop-list. You can use the new brush with any of the painting tools that appear in the drop-list.



To save the new brush in a folder other than the default Brushes folder, click **Edit Paths** in the Create Brush Tip dialog box. For

more information on changing file locations, see “Setting file locations” on page 691.

## To create a brush preset

Edit workspace

- 1 Choose a painting tool and modify any of the tool options.
- 2 On the Tool Options palette, click the **Presets** drop-list.
- 3 Click the **Save preset** button .  
The Save Preset dialog box appears.
- 4 Type a name for the brush preset.  
**Note:** You cannot use the names “Default” or “Last Used.”
- 5 To enter additional preset information, click **Options**, and then enter information in the **Author**, **Copyright**, and **Description** fields.
- 6 Click **OK**.



You can exclude any of the current brush settings from the preset by clicking the **Save** icon  associated with those settings in the Preset Includes list. A white “X” appears over the icon, indicating that this brush setting will not be saved with the preset.



## Importing and sharing brush tips

You can import custom brushes or create your own. For information about creating custom brushes, see “Creating brush tips and presets” on page 602.

After you create a custom brush tip, you can share it with others by sending them the brush file. If the brush uses a custom shape, you must share both the brush file and the custom shape file for that brush.

### To import a custom brush

Edit workspace

- 1 Choose **File ▶ Import ▶ Custom Brush**.  
The Import Custom Brush dialog box appears.
- 2 Click **Open**.
- 3 In the Open dialog box, navigate to the brush file that you want to import, and click **Open**.
- 4 In the Import Custom Brush dialog box, select the custom brushes that you want to import, and click **Add**.  
If you want to import multiple brushes, click **Add All**.
- 5 Click **OK** to import the custom brushes.

### To share brush tips

Edit workspace

- 1 Navigate to ...Documents\Corel PaintShop Pro\17.0\Brushes.  
Navigate to the folder in which you saved your custom brushes if it is different from the default Brushes folder.
- 2 Share the brush files (those with **.PspBrush** or **.PspScript** extensions) — for example, by attaching them to an e-mail message.

The recipient should save the brush files to ...Documents\Corel PaintShop Pro\17.0\Brushes, or to the folder that contains custom brushes.



If you are sharing brushes created from selections, you must share both the PspBrush file and the associated PspScript file.



## Painting and drawing with the Art Media tools

The Art Media tools let you create digital artwork that closely mimics real-world media, pigments, paints, and artists' tools.

This section presents the following topics:

- Working with Art Media layers
- Working with the Mixer palette
- Working with Art Media tools
- Using the Oil Brush tool
- Using the Chalk tool
- Using the Pastel tool
- Using the Crayon tool
- Using the Colored Pencil tool
- Using the Marker tool
- Using the Watercolor Brush tool
- Using the Palette Knife tool
- Using the Smear tool
- Using the Art Eraser tool

## Working with Art Media layers

Art Media layers are automatically created when you use the Art Media tools. You can also convert Art Media layers to raster layers.

You can choose to create a new image with an Art Media layer. You can also choose a canvas texture on which to apply the Art Media pigment, and you can apply a fill color or a canvas color to the texture. To add to the effect, you can dry or wet an Art Media layer at any time.

### To create an Art Media layer

Edit workspace

- Choose **Layers ▶ New Art Media Layer**.

A new Art Media layer  appears in the Layers palette.



You can also create a new Art Media layer by clicking the New Layer drop-list  on the toolbar of the Layers palette, and choosing **New Art Media Layer**.

### To dry or wet an Art Media layer

Edit workspace

- Choose Layers, and click one of the following options:
  - **Dry Art Media layer**
  - **Wet Art Media layer**



The Dry Art Media layer command and the Wet Art Media layer command can be selectively undone in the History palette.

## To modify Art Media layer properties

### Edit workspace

- 1 On the Layers palette, double-click the **Art Media** layer to display the Layer Properties dialog box.
- 2 Click the **Canvas Texture** tab.
- 3 Modify any of the layer's properties.

## Working with the Mixer palette

You can use the Mixer palette to blend colors and create paint swatches similar to those you would create by using a traditional artist's palette. Once you have created a color, you can use the Art Media brushes to apply it to the canvas.

If you blend colors too much, you can undo the 20 most recent Mixer Tube tool or Mixer Knife tool actions. You can also redo color mixing actions.

***Important!** The history of the actions in the Mixer palette is lost when you close the program; however, you can close the Mixer palette at any time while the program is open and not lose your changes.*

By default, the Mixer pages you create are 500 × 500 pixels. However, you can also create larger, custom mixer pages. You can also save the Mixer area as a Mixer page, which you can reload and use in another Corel PaintShop Pro session.

## To mix colors

Edit workspace

- 1 On the Materials palette, set the **Foreground and Stroke Property** box to **Color**, and choose a color from the **Frame**, **Rainbow**, or **Swatch** tab.

**Note:** When any Art Media tool is active, the mode buttons below the Foreground and Stroke Property and Background and Fill Property boxes are inactive.

- 2 On the Mixer palette, select the **Mixer Tube** tool .

- 3 In the Mixer area, drag to apply paint strokes.

If you want to change the width of the stroke, change the setting in the Size box.

**Note:** You can choose another color by repeating step 1.



- 4 Choose the **Mixer Knife** tool , and drag in the Mixer area to smear colors together.



You can toggle between the Mixer Knife tool and the Mixer Tube tool by using the right-mouse button. For example, you can apply paint by holding down the left mouse button and dragging; and you can mix the paint by holding down the right mouse button and dragging.

## To undo and redo color mixing

Edit workspace

- On the Mixer palette, click one of the following buttons:
  - **Unmix**  — lets you undo a Mixer Tube tool or Mixer Knife tool action
  - **Remix**  — lets you redo a Mixer Tube tool or Mixer Knife tool action



You cannot undo or redo Mixer Tube and Mixer Knife tool actions by choosing **Edit ▶ Undo** or **Edit ▶ Redo**, by clicking the **Undo** and **Redo** buttons on the Standard toolbar, or by pressing **Ctrl + Z** or **Ctrl + Alt + Z**.

## To use Mixer palette colors

Edit workspace

- 1 On the Mixer palette, choose the **Mixer Dropper** tool , and click a color in the Mixer area.

**Note:** Dragging around the Mixer area on the Materials palette updates the Foreground and Stroke property box with the current sampling position.

- 2 On the Tools toolbar, choose an Art Media tool.
- 3 Begin painting.

**Note:** The strokes will be applied on an Art Media layer. If this layer type is not the active layer, one is created automatically once you begin using the Art Media tool.

- 4 To choose another color, use the **Mixer Dropper** tool to choose the desired color from the Mixer area.

## You can also

---

Pan to other areas of the Mixer page Hold down the **Navigate** button  to display the entire Mixer page. Drag to enclose the desired area of the page.

---

Clear the Mixer page On the Mixer palette, choose **Clean Page**.

---



The size of the Dropper tool is determined by the **Size** setting on the Tool Options palette.

You can dry the Art Media layer, or make it wet again by choosing **Layers ▶ Dry Art Media layer** or **Layers ▶ Wet Art Media layer**. For more information on each Art Media tool, see “Working with Art Media tools” on page 614.

## To create a custom Mixer page

Edit workspace

- 1 Choose **File ▶ New** to display the New Image dialog box.
- 2 In the Image Dimensions group box, type values to set the dimensions for the Mixer page.  
**Note:** The width and height must be at least 500 pixels.
- 3 In the Image Characteristics group box, click the **Art Media Background** option.
- 4 Click the texture swatch in the Select canvas texture area, and choose a texture from the menu.  
**Note:** The texture acts like an invisible surface on which Art Media pigments are applied.
- 5 Click **OK**.  
**Note:** At this point you can apply Art Media pigment to the image.
- 6 On the Standard toolbar, click the **Save** button  to display the Save As dialog box.
- 7 Navigate to **X: Program Files(x86)\Corel\Corel PaintShop Pro X7\Corel\_17** for 32-bit or **X: Program Files\Corel\Corel PaintShop Pro X7 (64-bit)\Corel\_17** for 64-bit, where “X” indicates the drive on which Corel PaintShop Pro is installed.
- 8 Save the new image in the **.pspimage** file format.



## You can also

---

Save the Mixer area as a page

On the Mixer palette, choose **Save Page** or **Save Page As**, and type a name for the page.

---



You can also access Mixer pages from your user folder, ...Documents\Coreel PaintShop Pro\17.0\Mixer Pages.



You can fill the Mixer page with a color by marking the **Enable fill color** check box in the New Image dialog box, clicking the **Color** box, and choosing a fill color. Be aware, however, that you cannot sample this color, nor will the Art Media tools affect the color.

## To load Mixer area pages

Edit workspace

- 1 Click the **Load Mixer Page** button .
- 2 Click the Mixer page you want, or navigate to the folder where the Mixer page is stored.

**Note:** By default, Mixer pages are saved in ...Documents\Coreel PaintShop Pro\17.0\Mixer Pages.



You can also load a mixer page by clicking the **Mixer Menu** icon  and choosing **Load Page**.

## Working with Art Media tools

You can use the Art Media tools when working on Art Media layers. The Art Media tools let you simulate the rich, expressive results you get when working on physical pigment media such as paint, chalk, pastel, and pencil.

***Important!** Although the Art Media tools support Presets, they do not support custom brush tips like the Paint Brush tool and other raster painting tools.*

### The wet pigment media tools

The Oil Brush, Watercolor Brush, and Marker tools simulate the effect of painting with real wet pigment and tools. The Oil Brush even creates the effect of running out of paint at the end of a stroke. To get more paint, simply release the mouse button, and then drag more paint strokes.

The Oil Brush tool and the Palette Knife tool let you produce strokes with multiple colors on the brush head. This simulates the effect you can achieve by using a real painting palette and multiple wet pigments. Additionally, you can dry the wet strokes you have applied. For more information, see “To dry or wet an Art Media layer” on page 608.

### The dry pigment media tools

The Chalk, Pastel, Crayon, and Colored Pencil tools let you create effects that simulate artwork that you create with dry pigment media. Unlike the Oil Brush tool, the dry tools don't run out of pigment media. Furthermore, the pigment applied with these tools has less volume than that which is applied by using the Oil Brush tool.

## The Palette Knife, Smear, and Art Eraser tools

You can use the Palette Knife to apply and smear art media pigments. You can also use the Smear tool blend pigments as though you are using a finger or a cloth.

You can use the Art Eraser tool to erase pigment. However, if you are using the Art Eraser tool to erase pigment created with multiple paint strokes (such as those applied by the Oil Brush tool), it may take multiple strokes to clean the area. If you are using the tool to erase pigment created with the Chalk tool or the Colored Pencil tool, you'll achieve results with fewer strokes.

## Creating artistic rendering of photos

You can give a photograph image the look of a painting or drawing. By dragging the Artistic Media tool over a color, you select the pigment or paint color by sampling the data below the center of the brush regardless of the layer type. When you hold down the mouse button to begin the stroke, note that a single sample is performed, and the resulting color is used for the duration of the stroke.

## To use an Art Media tool

*Edit workspace*

- 1 On the Tools palette, choose one of the following tools:
  - Oil Brush
  - Chalk
  - Pastel
  - Crayon
  - Colored Pencil
  - Marker
  - Watercolor Brush

- Palette Knife
- Smear
- Art Eraser

2 On the Tool Options palette, click the **Presets** button and choose a preset brush.

If you want to adjust the preset brush, change any of the settings on the Tool Options palette.

## To adjust the brush size by using the keyboard

Edit workspace

To	Do the following
Increase or decrease brush size interactively	Hold down <b>Alt</b> , and drag.
Increase brush size by 1 pixel	Hold down <b>Alt</b> , and press <b>C</b> .
Increase brush size by 20 pixels	Hold down <b>Shift + Alt</b> , and press <b>C</b> .
Decrease brush size by 1 pixel	Hold down <b>Alt</b> , and press <b>X</b> .
Decrease brush size by 20 pixels	Hold down <b>Shift + Alt</b> , and press <b>X</b> .

## To create an artistic rendering of a photo

Edit workspace

- 1 With the image open, choose an Art Media tool that applies paint or pigment.
- 2 Mark the **Trace** check box on the Tool Options palette.
- 3 Place the cursor over the image where you want to sample an underlying color and drag to apply a stroke using the sampled color.

The resulting color is used for the duration of the stroke.



You can experiment with your results by adjusting the brush size and zoom level.

You can achieve accurate results by creating a color-based selection by using the Magic Wand tool, and applying the pigment or paint to the color sampled area.

## Using the Oil Brush tool

You can use the Oil Brush tool to simulate a dense medium that blends color by mixing with a thick medium, rather than through an overlay function. You can load the Oil Brush tool  with multiple colors. You can smear and blend colors by mixing them with oil that is already on the canvas.

There are a number of options for managing the reloading of the Oil Brush tool head between strokes. You can

- reload the brush with a solid color
- reload the brush by sampling from the Mixer page
- reload the brush with its current contents and optional amounts of color from the Mixer page
- leave the brush unloaded, and dip into the palettes or canvas after each stroke

Paint strokes applied by the Oil Brush tool are wet in terms of how strokes interact with other strokes by smearing or mixing together. For more information see “To dry or wet an Art Media layer” on page 608.

### Oil Brush tool options

Edit workspace

Oil Brush tool options include

- **Shape** — defines the shape of the brush tip

- **Size** — defines the size of the tool head in pixels
  - **Thickness** — defines the aspect ratio of the tool head. This setting is active only when the Fixed angle Head Tracking option is chosen.
  - **Rotation** — defines the angle of head rotation in degrees
  - **Head Tracking** — determines whether the tool head bends around the path of the user's stroke, or remains at a fixed angle
  - **Head Loading** — defines the percentage of material on the brush at the start of the stroke
  - **Viscosity** — defines the rate at which the material on the brush is applied, and thus the length of the stroke before your paint runs out
  - **Firmness** — defines the amount of splay in the brush, how the rendered line gets wider with more pressure, and how well it penetrates the surface on to which it is painting
  - **Bristle size** — affects the underlying noise function for texture and application of paint
  - **Auto Clean** check box — cleans the brush and reloads it with fresh paint at the start of a new stroke
- Note:** When unmarked, the brush head is not cleaned at the start of the stroke. Instead, the dirty head has a small amount of the current color added to whatever dirty head state exists from the previous stroke.
- **Clean** button — cleans the head and start the next stroke with fresh paint or pigment

- **Trace** check box — allows the current Art Media tool to select the pigment or paint color by sampling the data below the center of the brush regardless of the layer type.

***Important!** When you hold down the mouse button to begin the stroke, note that a single sample is performed and the resulting color is used for the duration of the stroke.*

## Using the Chalk tool

The Chalk tool  lets you create consistent, dry media over the course of a stroke. The pigment penetrates the canvas texture according to the pressure setting you choose. The Chalk tool does not have a bristle component to the stroke; instead, it is applied with a flat or angled edge that is affected by the texture of the canvas.

### Chalk tool options

Edit workspace

Chalk tool options include

- **Shape** — defines the shape of the chalk tip
- **Size** — defines the size of the tool head in pixels
- **Thickness** — defines the aspect ratio of the tool head
- **Rotation** — defines the angle of head rotation in degrees
- **Head Tracking** — defines whether the tool head bends around the path of the stroke, or whether it remains at a fixed angle
- **Trace** check box — allows the Chalk tool to select the pigment color by sampling the data below the center of the tool regardless of the layer type. (This feature works much the same way as the Clone Brush's Sample Merged tool option).

***Important!** When you hold down the mouse button to begin the stroke, note that a single sample is performed and the resulting color is used for the duration of the stroke.*

## Using the Pastel tool

Pastel is a dry media, softer than chalk, but like chalk it has infinite brush loading. Applied with the Pastel tool , its dry pigment tends to penetrate the canvas texture proportional to the pressure with which you apply it. Pastel pigments have a fixed viscosity that is slightly less than chalk, meaning the strokes you apply leave some volume on the canvas as they break from the pigment stick. Pastels do not have a bristle component to the stroke, instead presenting a flat or angled surface of the stick. The stroke edges fall off and break up based on the texture of the canvas.

Pastel is slightly shiny, interacts with itself by smearing slightly, and dirtying the tool head slightly when applied with light pressure. It loads the canvas more than chalk, breaking up more when applied, and this gives the appearance of volume to the surface.

### Pastel tool options

[Edit workspace](#)

Pastel tool options include

- **Shape** — defines the shape of the pastel tip
- **Size** — defines the size of the tool head in pixels
- **Thickness** — defines the aspect ratio of the tool head
- **Rotation** — defines the angle of head rotation in degrees
- **Head Tracking** — determines whether the tool head bends around the path of the user's stroke, or remains at a fixed angle



- **Trace** check box — allows the Pastel tool to select the pigment color by sampling the data below the center of the tool regardless of the layer type.

***Important!** When you hold down the mouse button to begin the stroke, note that a single sample is performed and the resulting color is used for the duration of the stroke.*

## Using the Crayon tool

Crayon is a dry media similar to chalk but with a wetter feel that prevents powdering. The tool has infinite pigment loading. As applied by the Crayon tool , its dry pigment tends to penetrate the canvas texture proportional to the pressure with which you apply it. This is due to Corel PaintShop Pro mimicking a solid tool head. The pigment leaves a slightly waxy volume that can smear for a short distance as it is painted over. Crayons do not have a bristle component to the stroke, instead presenting a flat or angled tool surface. The body of the stroke tends to have a fall-off and break up affected strongly by the canvas texture. However, crayon pigment is less transparent than chalk and does not powder.

Crayon is a little more shiny than pastel, smears itself slightly less, but does apply a tiny amount of matter to the canvas and can smooth over bumps if used repeatedly. This is because the volume that is laid down is viscous enough to fill dents but also dense enough to prevent large-range smearing.

## Crayon tool options

Edit workspace

Crayon tool options include

- **Shape** — defines the shape of the crayon tip
- **Size** — defines the size of the tool head in pixels
- **Thickness** — defines the aspect ratio of the tool head
- **Rotation** — defines the angle of head rotation in degrees
- **Head Tracking** — controls whether the tool head bends around the path of the user's stroke, or remains at a fixed angle
- **Trace** check box — allows the Crayon tool to select the pigment color by sampling the data below the center of the tool regardless of the layer type.

***Important!** When you hold down the mouse button to begin the stroke, note that a single sample is performed and the resulting color is used for the duration of the stroke.*

## Using the Colored Pencil tool

The Colored Pencil tool  lets you apply dry pencil strokes that blend when you apply light pressure, and overlay when you apply firm pressure. The Colored Pencil tool does not apply bump to a surface, and it will only smear when you apply pressure to the canvas. You can use the Smear tool to blend colored pencil strokes.

## Colored Pencil tool options

Edit workspace

Colored Pencil tool options include

- **Shape** — defines the shape of the pencil tip
- **Size** — defines the size of the tool head in pixels
- **Thickness** — defines the aspect ratio of the tool head

- **Rotation** — defines the angle of head rotation in degrees
- **Head Tracking** — controls whether the tool head bends around the path of the user's stroke, or remains at a fixed angle
- **Style** — determines the behavior of the Colored Pencil tool tip when using a stylus

Choose **Tilt** to change the style through a linear progression based upon the stylus tilt. Choose **Tip** to mimic using the very tip of a pencil. Choose **Edge** to mimic using the pencil's edge.

- **Softness** — defines the softness of the pencil lead, controlling how easily pressure or velocity break up the lead and cause it to powder into the canvas dents, or to smudge when applied
- **Trace** check box — allows the Colored Pencil tool to select the pigment color by sampling the data below the center of the tool

***Important!** When you hold down the mouse button to begin the stroke, note that a single sample is performed and the resulting color is used for the duration of the stroke.*

## Using the Marker tool

The Marker tool  lets you apply pigment that resembles drawing with a marker on a canvas. Marker pens are a slightly wet medium, though generally not wet enough to interact with other wet media. The pigment goes on the canvas with a multiply function, simulating the interaction of using a pen repeatedly on the same spot. Pens generally have a very sharp fall-off at the stroke edge, and there is full canvas penetration even at light pressure.

### Marker tool options

Edit workspace

Marker tool options include

- **Shape** — defines the shape of the marker tip

- **Size** — defines the size of the tool head in pixels
- **Thickness** — defines the aspect ratio of the tool head
- **Rotation** — defines the angle of head rotation in degrees
- **Head Tracking** — controls whether the tool head bends around the path of the stroke, or whether it remains at a fixed angle
- **Trace** check box — allows the Marker tool to select the pigment color by sampling the data below the center of the tool, regardless of the layer type

***Important!** When you hold down the mouse button to begin the stroke, note that a single sample is performed and the resulting color is used for the duration of the stroke.*

## Using the Watercolor Brush tool

You can use the Watercolor Brush tool  to simulate the transparent strokes of watercolor painting. Watercolor brushstrokes reveal the canvas texture and are wet in terms of how they interact with other strokes when you smear or mix them together. For more information see “To dry or wet an Art Media layer” on page 608.

To reload the Watercolor Brush tool with color, you can

- reload the brush with a solid color
- reload the brush by sampling from the Mixer page

## Watercolor Brush tool options

Edit workspace

Watercolor Brush tool options include

- **Shape** — defines the shape of the brush tip
- **Size** — defines the size of the tool head in pixels
- **Thickness** — defines the aspect ratio of the tool head. This setting is active only when the Fixed angle Head Tracking option is chosen.
- **Rotation** — defines the angle of head rotation in degrees
- **Head Tracking** — determines whether the tool head bends around the path of the user's stroke, or remains at a fixed angle
- **Viscosity** — defines the rate at which the material on the brush is applied, and thus the length of the stroke before your paint runs out
- **Firmness** — defines the amount of splay in the brush, how the rendered line gets wider with more pressure, and how well it penetrates the surface on to which it is painting
- **Bristle size** — affects the underlying noise function for texture and application of paint
- **Auto Clean** check box — cleans the brush and reloads it with fresh paint at the start of a new stroke

**Note:** When unmarked, the brush head is not cleaned at the start of the stroke. Instead, the dirty head has a small amount of the current color added to whatever dirty head state exists from the previous stroke.

- **Clean** button — cleans the head and start the next stroke with fresh paint or pigment
- **Trace** check box — allows the current Art Media tool to select the pigment or paint color by sampling the data below the center of the brush regardless of the layer type.

## Using the Palette Knife tool

The Palette Knife tool  interacts with the medium on the canvas. Generally, you use it with strokes placed by the Oil Brush tool as this is the only tool that applies large amounts of its medium. As the mass of the medium reduces in a spot, there is less to smear and using the Palette Knife tool has less effect. This means that the Crayon tool, which applies very little medium, is only slightly affected by the Palette Knife tool.

The method of loading or cleaning the Palette Knife tool is similar to the Oil Brush tool. You can clean it automatically after each stroke, retain the color picked up from the canvas, or allow manual cleaning. You can use the Palette Knife tool to apply pigment or smear it.

Paint strokes applied by the Palette Knife tool are wet in terms of how strokes interact with other strokes by smearing or mixing together. For more information, see “To dry or wet an Art Media layer” on page 608.

### Palette Knife tool options

Edit workspace

Palette Knife tool options include

- **Shape** — defines the shape of the knife tip
- **Size** — defines the size of the tool head in pixels
- **Thickness** — defines the aspect ratio of the tool head  
This setting is only active when the Fixed angle Head Tracking option  is enabled.
- **Rotation** — defines the angle of head rotation
- **Head Tracking** — controls whether the tool head bends around the path of the user’s stroke, or remains at a fixed angle

- **Head Loading** — defines the percentage of material on the brush at the start of the stroke
- **Auto Clean** check box — cleans the tool and dips it into fresh paint at the start of a new stroke
- **Clean** button — cleans the head and start the next stroke with fresh paint or pigment.

This button is only active when the **Auto Clean** check box is not marked.

- **Trace** check box — allows the Palette Knife tool to select the pigment or paint color by sampling the data below the center of the tool regardless of the layer type.

***Important!** When you hold down the mouse button to begin the stroke, note that a single sample is performed and the resulting color is used for the duration of the stroke.*

## Using the Smear tool

The Smear tool  lets you smear existing pigment, including pigment that has no volume on the canvas, such as pencil strokes. The tool simulates the effects of dragging a cloth or finger through chalk or pencil strokes on a canvas.

You can use the Smear tool to create a smudging effect on dry pigment, or to create a smearing effect on wet pigment.

### Smear tool options

Edit workspace

Smear tool options include

- **Shape** — defines the shape of the tool tip
- **Size** — defines the size of the tool head in pixels
- **Thickness** — defines the aspect ratio of the tool head

- **Rotation** — defines the angle of head rotation in degrees
- **Head Tracking** — controls whether the tool head bends around the path of the stroke, or whether it remains at a fixed angle

## Using the Art Eraser tool

The Art Eraser tool  lets you erase art media from an image. While this tool is not strictly realistic, it does provide you with the flexibility to erase mistakes, rather than undoing entire strokes.

### Art Eraser tool options

Edit workspace

Art Eraser tool options include

- **Shape** — defines the shape of the eraser tip
- **Size** — defines the size of the tool head in pixels
- **Thickness** — defines the aspect ratio of the tool head
- **Rotation** — defines the angle of head rotation in degrees
- **Head tracking** — controls whether the brush head bends around the path of the stroke, or whether it remains at a fixed angle





Corel PaintShop Pro has many advanced color features that let you work with color in many ways. For example, you can change the color depth of your images to prepare them for printing or the Web. You can control how your monitor displays colors and manage colors for output. You can also split images into color channels.

This section presents the following topics:

- Understanding color depth
- Viewing color depth information
- Increasing the color depth of an image
- Decreasing the color depth of an image
- Understanding color reduction methods
- Understanding palette options
- Working with image palettes
- Understanding color and color models
- Understanding how monitor colors and print colors differ
- Calibrating your monitor
- Working with color management
- Using color channels

## Understanding color depth

Color depth, also called bit depth, refers to the number of colors each pixel in an image can display. As the color depth increases, the number of colors an image can display increases. Each pixel's color information

is stored in a certain number of computer bits — from 1 bit to 48 bits. In a 1-bit image, each pixel can display only one of two colors — black or white. In images with greater bit depth, each pixel can display one of an increasingly large number of colors. High-end digital camera photos saved in the camera's RAW format contain the most colors, but they also require more hard drive space, and more system memory to display and work on them.

In Corel PaintShop Pro, you can use the following color depths:

- 2 colors
- 16 colors
- 256 colors
- 8-bit per channel RGB
- 8-bit per channel Grey
- 16-bit per channel RGB
- 16-bit per channel Grey

Before you change the color depth of your image, consider the following:

- Many effect and correction commands work on higher color depth images only. After you finish working on an image, you can decrease its color depth and save it in another format.
- Computer monitors also have a color depth that is determined by the monitor's capabilities as well as the selected color setting. If you display an image with a higher color depth than the monitor can display, the image has some color distortion.
- Some file formats limit the number of supported colors so that images display correctly on a variety of monitor types. For example, GIF images, a popular format for the Web, contain up to 256 colors (8-bit depth).

## Viewing color depth information

You can use Corel PaintShop Pro to view the color depth information for images. You can also check the color depth of a monitor to ensure it supports the color depth of the images with which you are working.

The number of colors actually used in an image is usually less than the color depth. For example, a 16 million-color image is capable of displaying that many colors, but may only use 50,000 colors. You can use Corel PaintShop Pro to view the number of colors used in an image or layer.

### To view the color depth of an image

Edit workspace

- Choose **Image ▶ Image Information**.

The Current Image Information dialog box appears. The color depth value for the image is displayed in the Pixel Depth/Color field in the Image group box.



You can also view the color depth information on the Status bar. The color depth information appears after the two numbers that display the pixel dimensions of the image.

You can also view color depth information on Overview palette by pressing **F9**, clicking the **Info** tab, and viewing the Color Depth field.

### To view the color depth of a monitor

Edit workspace

- 1 Choose **Help ▶ About PaintShop Pro**.
- 2 Click **System Info**.
- 3 Scroll down to the Video Driver Information section, and view the Number of Colors field.

## To view the number of colors in an image

Edit workspace

- Choose **Image ▶ Count Image Colors**.

## To view the number of colors in a layer

Edit workspace

- 1 On the Layers palette, click the layer that you want to check.
- 2 Choose **Layers ▶ Count Layer Colors**.

## Increasing the color depth of an image

If an image has a color depth of less than 24-bit, you may want to increase the color depth so you can use a wider range of effect and correction commands, many of which only work on images with 16 million colors. Depending on the color depth of your image, you can also increase an image to 16 colors (4-bit) or 256 colors (8-bit).

## To increase the color depth of an image

Edit workspace

- Choose **Image ▶ Increase Color Depth**, and choose one of the following:
  - **16 color palette**
  - **256 color palette**
  - **RGB - 8 bits/channel**
  - **RGB - 16 bits/channel**

Color depths not available for the active image are grayed out.



If your image has a palette, for example if you have a 256 color (8-bit) image, and you need to maintain the palette colors, you can save the palette before increasing the color depth. After editing the image, you can reload the palette. For more information, see “Working with image palettes” on page 641.

If you are increasing or decreasing several images to the same color depth, you can add a button to the toolbar that you can click to automatically set color depth. For more information, see “Customizing toolbars” on page 663.

## Decreasing the color depth of an image

If you are creating an image for on-screen viewing, you can decrease the number of colors to reduce the file size and ensure the image displays properly.

Before decreasing the color depth, consider the following:

- Most Corel PaintShop Pro effect and correction commands work on 16 million-color and grayscale images only.
- When you decrease the color depth, Corel PaintShop Pro flattens the image, which merges the data on all layers. However, you can add vector layers to images of any color depth.

If you are creating images for the Web, we recommend that you work with 16 million color (24-bit) images in the PsplImage file format. After editing the images, you can reduce the color depth of the images and prepare them for the Web by exporting the images using the GIF optimizer, JPEG optimizer, or PNG Optimizer.

Depending on the current color depth of your image, you can decrease its color depth to the color depths described below.

### **2 colors (1-bit)**

You can create a black-and-white image by decreasing the color depth of an image to 2 colors. For example, if your image is already black-and-white, you can change the color depth to two colors to reduce the file size.

## **16 Colors (4-Bit)**

When you have an image that has only a few colors, you can decrease the color depth of an image to 16 colors (4-bit). This color depth is useful for simple graphics on Web pages that you want to load quickly. The resulting image has an image palette that contains 16 specific colors. You can change any of those colors by editing the image palette. For information, see “Working with image palettes” on page 641.

## **256 colors (8-Bit)**

When you decrease the color depth of an image to 256 colors (8-bit), you can choose a Web-safe palette to ensure your image displays as expected regardless of the Web browser or monitor used to view the image. You can only convert color images to 256 Colors (8-bit). For information about converting images to 8-bit grayscale, see “To create an 8-bit grayscale image” on page 638.

## **Grayscale (8-bit)**

You can convert a color image to an 8-bit grayscale image that uses up to 256 shades of gray.

## **32K and 64K Colors (24-Bit)**

You can reduce the number of colors used in a 24-bit image by decreasing the color depth to 32K (32,000) or 64K (64,000) colors. Displaying images with 32K or 64K colors on older monitors results in better refresh rates than displaying 24-bit images with 16 million colors.

## **Decreasing color depth to a selected number of colors**

You can decrease the number of colors used in an image by specifying the number of colors that you want to use. When you specify the number of colors, Corel PaintShop Pro converts the image to the appropriate color depth. For example, if you specify 16 or fewer colors,

the image is saved as a 4-bit image. If you specify 17 to 256 colors, the image is saved as an 8-bit image. Specifying the number of colors is advantageous when saving to some file formats, such as GIF, because the file compression is sensitive to the number of colors in the image. For example, by using 100 colors instead of 256 colors, a smaller GIF file is created, even though both files are 8-bit images. Smaller files result in faster download times.

## To decrease the color depth to 2 colors

Edit workspace

- 1 Choose **Image ▶ Decrease Color Depth ▶ 2 Color palette**.
- 2 In the Palette Component group box, choose the color channel to use for the final image.

Choosing the **Grey values** option produces the best results in most cases. However, if the image consists mainly of a single color, selecting that color channel may produce the best results.

- 3 In the Reduction Method group box, choose a color reduction method.

For more information about color reduction, see “Understanding color reduction methods” on page 639.

- 4 In the Palette Weight group box, select an option:
  - **Weighted** — weighted palettes produce less dithering and sharper edges
  - **Non-weighted** — non-weighted palettes produce more dithering and softer edges

**Note:** Dithering places pixels of different colors or gray levels next to each other to simulate missing colors or grays.

- 5 Click **OK**.



You can also create a black-and-white image by choosing **Adjust ▶ Brightness and Contrast ▶ Threshold**. With this command, the color depth does not change. For more information, see “To convert a photo’s pixels to black and white” on page 197.

## To decrease the color depth to 16 colors

Edit workspace

- 1 Choose **Image ▶ Decrease Color Depth ▶ 16 Color palette**.
- 2 In the Palette group box, choose a palette option.  
For more information about setting Palette options, see “Working with image palettes” on page 641.
- 3 In the Reduction Method group box, choose a color reduction method.  
For more information about color reduction, see “Understanding color reduction methods” on page 639.  
**Note:** The Ordered Dither option is available only for the Windows color palette.
- 4 In the Options group box, mark or unmark these check boxes:
  - **Boost marked colors by** — when you have a selection in your image, this option lets you make the colors in the selection more important by a factor of the value you enter
  - **Reduce color bleeding** — makes the left-to-right bleed effect of colors less noticeable when you choose the Optimized Median Cut or the Optimized Octree palette and the Error Diffusion reduction method
- 5 Click **OK**.





If you want to emphasize the importance of certain colors in the conversion, create a selection of the area that you want to use before you decrease the color depth.

## To decrease the color depth to 256 colors

Edit workspace

- 1 Choose **Image ▶ Decrease Color Depth ▶ 256 Color palette**.
- 2 In the Palette group box, choose a palette option. For more information about setting Palette options, see “Working with image palettes” on page 641.
- 3 In the Reduction Method group box, choose a color reduction method.

For more information about reducing colors, see “Understanding color reduction methods” on page 639.

**Note:** The Ordered Dither option is available only for the Standard/Web-safe color palette.

- 4 In the Options group box, choose any of the following options:
  - **Boost marked colors by** — when you have a selection in your image, this option lets you make the colors in the selection more important by a factor of the value you enter
  - **Include Windows’ colors** — lets you include the 16 standard Windows colors in the converted image palette when you choose the Optimized Median Cut or the Optimized Octree palette option
  - **Reduce color bleeding** — makes the left-to-right bleed effect of colors less noticeable when you chose the Optimized Median Cut or the Optimized Octree palette and the Error Diffusion reduction method
- 5 Click **OK**.



If you want to emphasize the importance of certain colors in the conversion, create a selection of the area that you want to use before you decrease the color depth.

## To create an 8-bit grayscale image

Edit workspace

- Choose **Image** ▶ **Greyscale**.

## To decrease the color depth to 32K or 64K colors

Edit workspace

- 1 Choose **Image** ▶ **Decrease Color Depth**, and choose one of the following:
  - **32K Colors (8 bits/channel)** — reduces the number of colors to 32,000
  - **64K Colors (8 bits/channel)** — reduces the number of colors to 64,000
- 2 In the Reduction Method group box, select a color reduction method.  
For more information about reducing colors, see “Understanding color reduction methods” on page 639.
- 3 Click **OK**.

## To decrease the color depth to a selected number of colors

Edit workspace

- 1 Choose **Image** ▶ **Decrease Color Depth** ▶ **X Colors (4/8-bit)**.
- 2 Type or set the number of colors (from 2 to 256) in the **Number of colors** control.
- 3 In the Palette group box, select the palette options.  
For more information about setting Palette options, see “Working with image palettes” on page 641.

- 4 In the Reduction Method group box, choose a color reduction method.

For more information about reducing colors, see “Understanding color reduction methods” on page 639.

- 5 In the Options group box, choose any of the following options:
  - **Boost marked colors by** — when you have a selection in your image, this option lets you increase the colors in the selection by a factor of the value you enter
  - **Include Windows’ colors** — lets you include the 16 standard Windows colors in the converted image palette when you choose the Optimized Median Cut or the Optimized Octree palette
  - **Reduce color bleeding** — reduces the left-to-right bleed effect when you choose the Optimized Median Cut or the Optimized Octree palette and the Error Diffusion reduction method
- 6 Click **OK**.



If you want to emphasize the importance of certain colors in the conversion, create a selection of the area that you want to use before you decrease the color depth.

## Understanding color reduction methods

When you decrease the color depth of an image, you must select a color reduction method. Depending on the color depth you select, two or three of these methods are available:

- **Nearest Color** — replaces the original color of a pixel with the color in the newly generated palette that is closest to the original RGB value. This method eliminates dithering and produces a high-contrast image. This method works well with most simple graphics.

- **Error Diffusion** — replaces the original color of a pixel with the most similar color in the palette, but spreads the discrepancy between the original and new colors to the surrounding pixels. As it replaces a color (working from the top left to the bottom right of the image), it adds the “error,” or discrepancy, to the next pixel, before selecting the most similar color. This method produces a natural-looking image and often works well for photos or complex graphics. With the Error Diffusion method, you select the Floyd-Steinberg, Burkes, or Stucki algorithm for the dithering pattern.
- **Ordered Dither** — adjusts adjacent pixels so that two colors give the illusion of a third color and intermingles pixels to produce patterns based on a known palette. You can use this method to give the image the appearance of containing more colors than it actually does. Images may appear to be composed of cross-hatches and dots and may have distinct light and dark areas.

When you decrease an image’s color depth, don’t be intimidated by the mathematical algorithms that make up the color reduction methods and the palette options. It’s recommended that you start with the default settings. If you like the result, try out several other combinations of settings. It take can take some experimentation to find the right options.

## Understanding palette options

When you decrease the color depth of an image, you must select a palette option. Depending on the color depth you select, two or three of these methods are available:

**Optimized Median Cut** — measures and ranks each color by how frequently it occurs in the image, then uses the most frequently occurring colors to determine the new palette. Even if your image contains fewer colors than the palette that is generated, this method may not represent each color exactly. The method, therefore, is not as

accurate as the Optimized Octree method, but it is better at weighting color importance.

**Optimized Octree** — creates an eight-level “tree” with eight branching nodes totaling 256 individual “leaves” or colors to determine the new palette. This method attempts to reproduce each color in the original image, so if your image contains fewer colors than the palette that is generated, every color in the image is represented. This method is faster and more accurate than Optimized Median Cut, but is not as good at weighting color importance.

**Windows** — changes each pixel’s color to the nearest color in the Windows palette

**Standard/Web-Safe Palette** — changes each pixel’s color to the nearest color in the standard Web-safe palette. You can use this method to create images for the Web that can be viewed without color distortion on most monitors.

## Working with image palettes

An image palette is a collection of colors that an image uses — similar to a painter’s palette. An image palette is a subset of all the colors your monitor can display. Not all images have image palettes — only images with color depths between 16 and 256 colors have palettes that you can fine-tune and edit.

Images with a color depth of 16 million colors do not have an image palette because they can contain all the colors your computer can display. For these images, you can load an image palette to decrease the image’s color depth to 256 colors (8-bit). Loading a palette produces the same result as decreasing color depth, except that you are controlling which colors are used in the converted image. For more information about color depth, see “Understanding color depth” on page 629.

You can also create and save your own palettes. Preset palettes are located in the Palettes folder of the Corel PaintShop Pro program folder. When you save a palette, you can load it into other images. This is a good way to maintain consistent colors across several images. Saving a palette is also useful if you are making many color changes and want to save a backup copy of the palette.

If you are using a palette with the current image only, you don't need to save it as a separate file because the palette colors are saved with the image itself.

### **Editing the palette of a grayscale image**

If you edit the color palette for a grayscale image, you are prompted to change the image to 8-bit indexed color. This allows you to add color to your grayscale image.

### **Using the Web-Safe color palette**

Corel PaintShop Pro includes a Web-safe, 256-color palette, the Safety palette. Images using this palette can be viewed without color distortion on most computer monitors. There are three ways to use this palette on an image:

- You can load the Safety palette into your image. For 16 million color (24-bit) images, this flattens the layers and reduces the image's color depth to 256 colors (8-bit), which limits the available commands.
- You can decrease the image's color depth to 256 colors and select the Standard/Web-Safe Palette option. Decreasing the color depth also flattens layers and makes some commands unavailable.
- You can edit the image in 16 million colors (saving it to the PspImage file format), then use the GIF Optimizer or PNG Optimizer to export a copy of the image. These optimizers use the Web-safe palette by default and decrease the color depth in the saved image. This is recommended because it does not change

the color depth or flatten the layers of your original PsdImage file. For more information about saving optimized images, see “Saving images for the Web” on page 757.

## Making a palette color transparent

Paletted images (those with 256 or fewer colors) do not support transparent backgrounds, but you often need a way to make part of your image transparent when you are using an image on a Web page. For example, you may have a round logo and you want the background of the Web page to display around the logo.

Most Web browsers can choose not to display one color, effectively making it transparent. In Corel PaintShop Pro, you have two ways to make a color transparent:

- You can make one color in an image palette transparent. The color can be the background color or any color from the image. To set a transparent color, the image must have only one layer and use an image palette, which means the image must have a color depth less than 16 million colors (24-bit).
- You can edit a 16 million-color image, save it to the PsdImage file format, then use the GIF or PNG optimizer to export a copy of the image. With these optimizers you can set the transparency of the image. This is recommended because it does not change the color depth or flatten the layers of your original PsdImage file. For more information saving optimized images, see “Saving images for the Web” on page 757.

## To edit an image palette of 16 to 256 color images

*Edit workspace*

- 1 Choose **Image ▶ Palette ▶ Edit Palette**.

This command is not available for 16 million color images.

- 2 Perform one or more tasks from the following table, and click **OK**.

To	Do the following
Change the sort order of the colors	Select an option from the Sort Order drop-list.
Replace a color	Double-click the color, choose a color from the Color page, and click <b>OK</b> .
Reset the palette to the original colors	In the Edit Palette dialog box, click <b>Revert</b> .

## To save an image palette

### Edit workspace

- 1 Choose **Image ▶ Palette ▶ Save Palette**.

The Save Palette dialog box appears.

- 2 Type a name for the palette in the Filename box.

- 3 Click **Edit Paths**.

The File Locations dialog box appears.

- 4 Choose the folder where you want to save the palette in the Palette Folder group box.

If you save the palette in the Palettes folder of the Corel PaintShop Pro program folder, you can access the palette as a preset.

- 5 Click **OK**.

- 6 In the **Save palette as** group box, select a palette format option:

**PSP palette** — the default palette format

**Microsoft palette** — palette format used for other applications

- 7 Click **Save**.

Corel PaintShop Pro automatically adds the .PspPalette filename extension when you save the file.



## To load an image palette

Edit workspace

- 1 Choose **Image ▶ Palette ▶ Load Palette**.

The Load Palette dialog box appears.

- 2 In the **Palette** drop-list, click the **File Locations** button .

The File Locations dialog box appears.

- 3 Choose the folder which contains the palette you want to load, and choose a palette.

Preset image palettes are stored in the Palettes folder of the Corel PaintShop Pro program folder.

- 4 Click **OK**.

- 5 In the Apply Palette Using group box, select one of the following options:

- **Nearest color matching** — changes each image color to the color in the palette that is the closest match
- **Error diffusion dithering** — attempts to maintain the image appearance by dithering colors that are not in the palette. Dithering places pixels of different colors next to each other to simulate missing colors.
- **Maintain indexes** — assigns each color in the palette a sequential index number and does the same for each color in the image. Each color in the image is then changed to the like-numbered color in the palette.

- 6 Click **Load**.

The palette is loaded and the image colors are updated.



If you load a palette and do not like the results, you can revert to the original image by pressing **Ctrl + Z** to undo the action.

## To load the Web-safe color palette

Edit workspace

- 1 Choose **Image ▶ Palette ▶ Load Palette**.

The Load Palette dialog box appears.

- 2 In the **Palette** drop-list, click the **File Locations** button .

The File Locations dialog box appears.

- 3 Navigate to the Palettes folder in the Corel PaintShop Pro program folder, and choose **Safety**.

- 4 In the Apply Palette Using group box, choose one of the following options:

- **Nearest color matching** — changes each image color to the color in the palette that is the closest match.
- **Error diffusion dithering** — attempts to maintain the image's appearance by dithering colors that are not in the palette. Dithering places pixels of different colors next to each other to simulate missing colors.
- **Maintain indexes** — assigns each color in the palette a sequential index number and does the same for each color in the image, then changes each color in the image to the like-numbered color in the palette. This option is not available for 16 million-color images.

- 5 Click **Load**.

## To make one image color transparent

Edit workspace

- 1 Choose **Image ▶ Palette ▶ Set Palette Transparency**.

If you are prompted to reduce the color depth and number of layers, click **Yes** to continue and then choose the options for decreasing color depth.

- 2 On the Set Palette Transparency dialog box, choose one of the following options:

- **Set the transparency value to the current background color** — makes the background color transparent
- **Set the transparency value to a palette entry** — specifies a color to be transparent. Click the color in the image, or click the color box to select from the current color picker.

If you want to view the transparency, click **Proof**.

### 3 Click **OK**.

The color is now transparent; however, it may still be displayed until you hide it.

## To view or hide the transparency of a color

Edit workspace

- Choose **Image ▶ Palette ▶ View Palette Transparency**.

## Understanding color and color models

We usually think of color as a quality inherent in an object — for example a red car or a green frog. But color is really what we see as a result of three factors interacting: light, the object, and the observer. As rays of light hit the object, the object absorbs some light and reflects some light. We see the reflected light and perceive it as color. Different colors reflect light of different wavelengths. Human eyes are able to perceive thousands of colors in the visible spectrum of light.

When you apply ink to paper, the colors we see result from the light that the ink reflects. Computer monitors use emitted light rather than reflected light. The colors we see result from light emitted from the screen.

To describe how color is produced or perceived, we use color models. Computer monitors display colors by producing varying amounts of red, green, and blue light — the RGB color model. Human eyes perceive color by its hue, saturation, and lightness levels — the HSL color model. With Corel PaintShop Pro you can select colors using

either the RGB or HSL color model. You can also output images using the CMYK (Cyan, Magenta, Yellow, Black) model, which is used for high-end printing applications.

RGB is the default color model in Corel PaintShop Pro. For information about changing the default color model, see “To set Palettes preferences” on page 673. Corel PaintShop Pro uses your preferred color model (RGB or HSL) whenever color values are displayed. When you select colors from the Color page, you are able to enter RGB or HSL values regardless of your preference setting. The color model used to display color values on-screen has no effect on how colors are printed.

## RGB model

All colors on your computer screen are created by mixing red, green, and blue light in varying proportions and intensities. When these primary colors are mixed in equal proportions, they create yellow, cyan, and magenta. Adding all the colors together creates white.

Each primary color (red, green, and blue) is assigned a value from 0 (none of the color present) to 255 (the color at full strength). For example, pure red is produced by combining a red value of 255, a green value of 0, and a blue value of 0. Yellow is a combination of a red value of 255, a green value of 255, and a blue value of 0. Setting all three values to 255 produces white; setting all three values to 0 produces black. When all three colors are set to the same value, the result is gray.

## HSL model

The HSL model is based on how the human eye perceives color using the characteristics of hue, saturation, and lightness. Each characteristic is assigned a value from 0 to 255. The three characteristics are described as follows:

- **Hue** — the color reflected from an object, such as red, yellow, or orange. Each hue value is assigned based on its position on the

color wheel. On the Color page's Color wheel, colors are assigned counter-clockwise from the top. Red is at the top (value 0) and as you move around the wheel the colors go through orange, yellow, green, blue, purple, and back to red.

- **Saturation** — the purity or vividness of the color. Saturation represents the amount of gray in the color, from 0 (entirely gray) to 255 (fully saturated color).
- **Lightness** — the perceived amount or intensity of light in the color. Lightness ranges from 0 (no light, or black) to 255 (total lightness, or white). At 50 percent lightness, or a value of 128, a color is considered pure. For example, pure red has a hue of 255, a saturation of 255 (100 percent) and a lightness of 128 (50 percent). For pure blue, the hue is 170, saturation is 255 and lightness is 128.

## CMYK model

The CMYK model is based on the fact that ink on paper both absorbs and reflects light. As white light strikes the ink, part of the color spectrum is absorbed and part is reflected back to your eyes (resulting in the color you see).

In this model, the primary colors cyan (C), magenta (M), and yellow (Y) combine in varying proportions to produce a variety of colors. When the three colors are combined, they produce black. Because impurities in the ink make it difficult to produce a true black, a fourth color, black (K), is added.

Combining inks in this way is called four-color process printing. It is used by printing services and high-end color printers.

Although you cannot create images in Corel PaintShop Pro using the CMYK model, you can produce color separations that can be printed on CMYK printers. There are two ways to do this: You can split the images into CMYK channels, or you can print color separation pages.

CMYK channels are simply four separate grayscale images that represent the percentage and location of cyan, magenta, yellow, and black in the image. For more information about working with color channels, see “Using color channels” on page 654.

When you print CMYK separations, Corel PaintShop Pro prints a separate grayscale page for each primary color. You can then use these pages as “color plates” when working with a printing service. For more information about CMYK color separations, see “Printing CMYK color separations” on page 745.

## Understanding how monitor colors and print colors differ

Computer monitor colors and printed colors may often be quite different — which is a challenge when you are trying to match a certain color. Colors can also appear different from monitor to monitor.

Image colors on a monitor are influenced by a variety of factors:

- the color range, called the color gamut, of the input device (such as the scanner or camera)
- the manufacturer and age of the monitor
- the monitor’s brightness and contrast settings

When you print an image, you introduce other factors that influence color:

- the quality and absorption properties of the paper
- the color gamut of the printer
- the conversion of RGB values from the monitor to the CMYK values of the printer’s ink

This conversion is a challenge because of the different approaches to color between monitors and printers. Because monitors use light to display color, they use additive colors—when you add them together,

they produce white. Conversely, when you remove all monitor colors you produce black. Because printers use ink to display color, they use subtractive colors—when you remove colors, you produce white, and when you add all printer colors you produce black. As a result, monitors and printers have different color gamuts. Although they share many of the same colors, there are some colors a monitor can display that a printer can't print and some colors a printer can print that a monitor can't display.

Given all the factors that go into producing colors, how do you go about making colors accurate and consistent? Try these options:

- You can calibrate your monitor every few months.
- You can get to know the differences between your monitor's colors and your printer's colors so you can adjust your images as needed. You can do this by printing out several photos or other images and comparing them to the image on-screen. For example, your printer may always print colors darker than your monitor displays them. Knowing this, you can modify the lightness of your images accordingly.
- You can use Windows Color Management, which helps to improve color consistency across devices.

## Calibrating your monitor

It is important that the colors represented on your monitor are reasonably accurate and meaningful. For example, red should really look red and not like a shade of orange or purple, and 50% gray shouldn't look like light gray or dark gray.

In Corel PaintShop Pro, you can use a wizard that walks you through the process of calibrating your monitor so it displays accurate colors. At the end of the process, you can save a color profile for your monitor and apply the adjustments.

## To calibrate your monitor

Edit workspace

- 1 Choose **File** ▶ **Color Management** ▶ **Monitor Calibration**.

The Monitor Calibration wizard appears.

- 2 Click the **Maximize** button .

Maximizing the dialog box eliminates distracting background colors.

- 3 Follow the instructions in the wizard, and click **Finish** to exit the wizard.

- 4 In the Save As dialog box, type a name for your monitor profile in the File Name box, and click **Save**.

If you have Administrator privileges for your computer, the profile becomes the active monitor profile.

If you do not have Administrator privileges for your computer, a message appears informing you to contact your System Administrator to install the profile.



You can also calibrate red, green, and blue tones for your monitor by marking the **Advanced options** check box when it appears on a wizard page.

You can clear the calibration settings for a wizard page by clicking **Reset**.

## Working with color management

If you are preparing professional quality digital images, you can enable or disable color management settings. Additionally, every RGB image in Corel PaintShop Pro has a profile associated with it. By default, these advanced color settings are enabled, allowing the application to make use of a consistent color working space. You can define advanced features for color working spaces and profiles. For example, you can set



a CMYK profile that determines how CMYK images are processed when you split or combine CMYK channels, or when you output to a CMYK TIF file.

## To set up profiles for color management

Edit workspace

- 1 Close any open images.
- 2 Choose **File ▶ Color Management ▶ Color Management**.  
The Color Management dialog box appears.  
**Note:** The recommended working space for Corel PaintShop Pro is sRGB.  
If necessary, mark the **Enable Color Management** check box to access the controls in this group box.
- 3 Choose the **Basic color management** option to access controls for your monitor and printer.
- 4 In the **Monitor Profile** drop-list, choose the monitor profile you want to use.  
If you're using multiple monitors with your computer, the profile you choose only applies to the primary display.
- 5 In the **Printer Profile** drop-list, choose the printer profile you want to use.  
If you're using multiple printers with your computer, the profile you choose only applies to the primary printer.
- 6 In the **Rendering Intent** drop-list, choose the setting that matches your intended output.  
This setting affects how the option you choose in the **Printer Profile** drop-list is used.
- 7 Click **OK**.



Only valid and correctly installed profiles appear in the profile lists.

If you have Administrator privileges for your computer, the profile you save becomes the active monitor profile. If you are a restricted user, you must contact your System Administrator to install the profile.



You can set your printer to simulate a printing press by choosing the **Proofing** option, choosing a device in the **Emulated Device Profile** drop-list, and choosing the appropriate option in the **Rendering Intent** drop-list.

## To define a color working space and CMYK profile

Edit workspace

- 1 Close any open images.
- 2 Choose **File** ▶ **Color Management** ▶ **Color Working Space**.

The Color Working Space dialog box appears.

**Note:** The recommended working space for Corel PaintShop Pro is sRGB.

- 3 In the **Color Working Space** drop-list, choose a color space.
- 4 In the **CMYK Profile** drop-list, choose a profile to be used for the CMYK-related operations in the application.

The drop-list includes the default CMYK profile and any profiles that you have added.

- 5 Click **OK**.

## Using color channels

Image files store color information in channels, or planes, of colors. You can separate an image into RGB, HSL, or CMYK color channels. An RGB image has three channels: red, green, and blue. An HSL image has

three channels: hue, saturation, and lightness. Although you cannot create or edit an image using the CMYK model, you can still split the image into four channels: cyan, magenta, yellow, and black.

You can create a new grayscale image for each color channel; the original image is not affected. For example, an HSL image is split into separate grayscale images named “Hue,” “Saturation,” and “Lightness.” Each grayscale image represents the percentage and location of a color (such as red) or a characteristic (such as lightness) within the image.

You can edit the grayscale images and use them to create interesting effects or masks. You can then combine them again. If you split an image into CMYK channels, you can then send the four grayscale images to a printing service. You can also print CMYK separations directly.

You can split images into RGB, HSL, or CMYK color channels regardless of the type of color model (RGB or HSL) you choose as a display preference.

Color channels give you increased image-editing options. You can create a color shift by splitting an image into HSL channels, modifying the Hue channel, then combining the channels. You can also use a channel grayscale to create a selection.

## To split an image into color channels

Edit workspace

- 1 Choose **Image ▶ Split Channel**, and choose one of the following:
  - **Split to RGB**
  - **Split to HSL**
  - **Split to CMYK**

A new grayscale image opens for each color channel.

## To combine color channels

Edit workspace

- 1 Open each color channel file.
- 2 Choose **Image ▶ Combine Channel**, and choose one of the following:
  - **Combine from RGB**
  - **Combine from HSL**
  - **Combine from CMYK**
- 3 For each **Channel Source** drop-list, select the name of the file that contains that channel. For example, in the Combine RGB dialog box, select the file Red1 as the red channel source.

**Note:** If you are combining channels that you split with the Split Channel command, mark the **Sync** check box to have Corel PaintShop Pro automatically fill in the Channel Source boxes with matching file names.

- 4 Click **OK**.

A new file is created from the selected channels.



In Corel PaintShop Pro, you can customize workspaces, the menu system, toolbars, keyboard shortcuts, application preferences, file format preferences and associations, resources, and viewing options. You can even choose another language in which to use the application.

This section presents the following topics:

- Viewing and hiding toolbars
- Using custom workspaces
- Customizing the menu system
- Customizing toolbars
- Creating custom toolbars
- Customizing keyboard shortcuts
- Setting Undo preferences
- Setting View preferences
- Setting Display and Caching preferences
- Setting Palettes preferences
- Setting Units preferences
- Setting Transparency and Shading preferences
- Setting Warnings preferences
- Setting Auto Action preferences
- Setting Miscellaneous preferences

- Setting Manage workspace preferences
- Setting Auto-Preserve preferences
- Choosing a default workspace
- Setting file format preferences
- Setting file format associations
- Setting file locations
- Managing resources
- Setting plug-in preferences
- Selecting Web browsers
- Setting Autosave preferences
- Resetting all preferences
- Switching languages
- Adjusting general viewing options
- Accessing tools and commands from previous versions of Corel PaintShop Pro
- Protecting and restoring the Corel PaintShop Pro database

## Viewing and hiding toolbars

You can choose which toolbars are displayed.

### To select which toolbars are displayed

*Edit workspace*

- 1 Click **View** ► **Customize** to display the Customize dialog box.
- 2 Click the **Toolbars** tab.
- 3 Mark the check box next to the name of the toolbar you want to display.



You cannot hide the Menu bar.



You can also open the Customize dialog box by right-clicking the Menu bar, Tool palette, or Tool Options palette, and choosing **Customize**.

## Using custom workspaces

The Corel PaintShop Pro workspace consists of palettes, toolbars, and open images. You may find that the way you arrange the workspace while editing photos may differ from the arrangement while using the Web tools. Fortunately, Corel PaintShop Pro lets you save and use any number of workspace arrangements.

***Important!** Workspace files do not include an actual copy of any open images. Workspace files only reference the name and location of an image. If you delete an image from your computer, the image will not appear in the workspace.*

### Saving custom workspaces

When you save a workspace, Corel PaintShop Pro saves the information in a PSPWorkspace file. The following information is stored:

- ruler, grid, and guide information
- menu, palette, and toolbar settings, locations, and docking status
- full screen edit mode status
- open images, including zoom levels and scroll bar locations

### Loading workspaces

You can load a custom workspace. Tool, menu, and palette positions change to reflect the workspace you are loading.

If you had two windows open for the same image when you saved the workspace, they both open again. If an image from the workspace is already open, Corel PaintShop Pro applies the workspace settings to the open image.

## Deleting saved workspaces

If you no longer want to use a saved workspace, you can delete it.

## To save the current workspace

Edit workspace

Manage workspace

- 1 Choose **File ▶ Workspace ▶ Save**.

The Save Workspace dialog box appears.

- 2 In the **New Workspace Name** field, type a name for the new workspace.
- 3 Click **Save**.



If your workspace contains any modified images that you have not saved, you are prompted to save the changes to your image. To save the image changes and the workspace, click **Yes**. To save the workspace, but not the image changes, click **No**. To cancel saving the workspace and the image changes, click **Cancel**.



You can open the Save Workspace dialog box by pressing **Shift + Alt + S**.

You can save the workspace in a folder other than the program default folder, by clicking the **File Locations** button in the Save Workspace dialog box. For more information about editing paths, see “Setting file locations” on page 691.



## To load a workspace

Edit workspace

Manage workspace

- 1 Choose **File ▶ Workspace ▶ Load**.

The Load Workspace dialog box appears.

- 2 Click one of the following:

- **Yes** — saves the current workspace before loading another one
- **No** — does not save the current workspace before loading another one

- 3 Select the workspace file you want to load.

- 4 Click **Load**.



You can open the Load Workspace dialog box by pressing **Shift + Alt + L**.

You can load the workspace from a folder other than the program default folder, by clicking the **File Locations** button in the Load Workspace dialog box. For more information about editing paths, see “Setting file locations” on page 691.

You can also load a recently used workspace by choosing it from the list of recent workspaces located at the bottom of the **File ▶ Workspace** menu.

## To delete a saved workspace

Edit workspace

Manage workspace

- 1 Choose **File ▶ Workspace ▶ Delete**.

The Delete Workspace dialog box appears.

- 2 Select the workspace file you want to delete.

- 3 Click **Delete**.



You can open the Delete Workspace dialog box by pressing **Shift + Alt + D**.

## Customizing the menu system

When you display the Customize dialog box, the entire Corel PaintShop Pro workspace transforms into customize mode. You can choose which menus are displayed and how a menu opens when you select it. You can also reset the menus to the default settings.

### To animate the menu system

Edit workspace

- 1 Choose **View ▶ Customize**.

The Customize dialog box appears.

- 2 Click the **Menu** tab.
- 3 In the **Select context menu** drop-list, select the menu that you want to modify.
- 4 From the **Menu animations** drop-list, choose one of the following animation styles for menu opening:
  - **None** — applies no animation effect
  - **Unfold** — opens the menu starting from its top-right corner to its bottom-left corner
  - **Slide** — opens the menu from top to bottom
  - **Fade** — gradually opens the entire menu, from a faded look to fully visible
- 5 Click **Close**.

### To reset the menus

Edit workspace

- 1 Choose **View ▶ Customize**.

- The Customize dialog box appears.
- 2 Click the **Menu** tab.
  - 3 In the Application Frame Menus group box, click **Reset**.

## Customizing toolbars

When you display the Customize dialog box, the entire Corel PaintShop Pro workspace transforms into customize mode. You can click and drag almost any menu command or tool to any other menu or toolbar. You can add or delete commands from the menus on the Menu bar.

### To move a toolbar button

Edit workspace

- With the Customize dialog box displayed, drag the item to another toolbar.

### To add a command button to a toolbar

Edit workspace

- 1 Choose **View ► Customize**.

The Customize dialog box appears.

- 2 Click the **Commands** tab.
- 3 From the Categories list, select a category.

**Note:** Corel PaintShop Pro groups related commands into categories. For example, click the **File** category to display all File menu commands. To list all Corel PaintShop Pro commands at once, choose **All Commands**.

- 4 From the **Commands** list, drag a command to a toolbar.

## To remove a command button from a toolbar

Edit workspace

- 1 With the Customize dialog box displayed, drag the item to an empty workspace area or an empty area outside a toolbar.
- 2 Release the mouse button when you see the cursor change to this shape: .

## To reset all toolbars

Edit workspace

- 1 Choose **View ▶ Customize**.  
The Customize dialog box appears.
- 2 Click the **Toolbars** tab.
- 3 Click **Reset All**.  
All toolbars revert to the default settings.



You can reset a specific toolbar to its default settings by choosing it from the Toolbars list and clicking **Reset**.

You can also open the Customize dialog box by right-clicking the Menu bar, Tool palette, or Tool Options palette, and choosing **Customize**.



You can rearrange a button in relation to the separator by dragging the button to the desired location.

You can also open the Customize dialog box by right-clicking the Menu bar, Tool palette, or Tool Options palette, and choosing **Customize**.

## Creating custom toolbars

You can create a custom tool bar with your favorite commands and tools.

## To create a custom toolbar

Edit workspace

- 1 Choose **View ▶ Customize**.

The Customize dialog box appears.

- 2 Click the **Toolbars** tab.

- 3 Click **New**.

The Toolbar Name dialog box appears.

- 4 Type a name for the new toolbar, and click **OK**.

A small, empty toolbar appears, and the new toolbar is added to the Toolbar list.

**Note:** Drag the new toolbar off to the side of the Customize dialog box so you can see it better.

- 5 Click the **Commands** tab.

- 6 In the **Categories** list, click a menu.

- 7 From the **Commands** list, drag command icons to the new toolbar.

- 8 When you are finished adding commands, click **Close**.



You can add separator bars, if necessary, to place commands into desired groups. For more information about customizing toolbars, see “Customizing toolbars” on page 663.

You can also open the Customize dialog box by right-clicking the Menu bar, Tool palette, or Tool Options palette, and choosing **Customize**.

## To delete a custom toolbar

Edit workspace

- 1 Choose **View ▶ Customize**.

The Customize dialog box appears.

- 2 Click the **Toolbars** tab.

- 3 In the **Toolbars** list, select the name of the custom toolbar you want to delete.
- 4 Click **Delete**.
- 5 Click **Close**.

## Customizing keyboard shortcuts

You can view existing keyboard shortcuts, assign a keyboard shortcut to menu commands, bound scripts, and tools, and even modify keyboard shortcuts.

### To view the default keyboard shortcut

Edit workspace

Manage workspace

- 1 Choose **Help ▶ Keyboard Map**.



The Help Keyboard dialog box appears.

- 2 In the **Category** drop-list, select a category.

**Note:** Corel PaintShop Pro groups related commands into categories. For example, if you pick the **File** category, all the commands in the file menu are displayed. To list all commands at once, choose **All Commands**.

The commands and their shortcut keys are displayed in the list, sorted by command name. Click any column heading (Command, Keys, or Description) to sort alphabetically by that column.



You can print the list of the current category of shortcut keys by clicking the **Print**  button on the toolbar of the Keyboard Map dialog box. You can also copy information about commands to the Clipboard by selecting information on the Keyboard Map and then clicking the **Copy**  button.

## To assign a keyboard shortcut

Edit workspace

- 1 Choose **View ▶ Customize**.

The Customize dialog box appears.

- 2 Click the **Keyboard** tab.
- 3 In the **Category** drop-list, select a category.

**Note:** Corel PaintShop Pro groups related commands into categories. For example, if you pick the **File** category, all the commands in the file menu are displayed. To list all commands at once, choose **All Commands**.

- 4 In the **Commands** list, select a command name.

The description of the command and any assigned shortcut keys are displayed.

- 5 Click in the **Press New Shortcut Key** field.

- 6 Press the new keyboard shortcut you want to assign to the command.

The shortcut appears in the Press New Shortcut Key field. If the shortcut is already assigned to another command, a message is displayed above the field.

- 7 Click **Assign**.
- 8 Assign more shortcut keys, or click **Close**.

## To modify a keyboard shortcut

Edit workspace

- 1 Choose **View ▶ Customize**.

The Customize dialog box appears.

- 2 Click the **Keyboard** tab.
- 3 In the **Category** drop-list, choose the menu associated with the command, script, or tool for which you want to modify the keyboard shortcut.

- 4 In the **Commands** list, click the item for which you want to modify the keyboard shortcut.
- 5 In the **Current Keys** field, click the shortcut.
- 6 Click **Remove**.
- 7 Click inside the **Press New Shortcut Key** field so the cursor is blinking, and press the keyboard keys you want to assign as the new shortcut.  

If the keyboard combination you entered is already assigned, a message is displayed above this field. If the keyboard combination is not assigned, "Assigned to: [Unassigned]" is displayed above the field.
- 8 Click **Assign**.
- 9 Click **Close**.

## Setting Undo preferences

The Undo settings control some behavior of the Undo and Redo commands, as well as one option for the History palette.

### To set Undo and Redo preferences

Edit workspace

Manage workspace

- 1 Choose **File** ▶ **Preferences** ▶ **General Program Preferences**.
- 2 From the left pane, choose **Undo**.
- 3 To enable Corel PaintShop Pro to undo actions, mark the **Enable the undo system** check box.  

This enables you to set all the items in this area of the Undo page.
- 4 Perform one or more of the following tasks and click **OK**.



To	Do the following
Set the amount of disk space undo and redo steps can use	Mark the <b>Limit undo/redo disk usage to</b> check box, and type or set a value in the control.
Set the number of undo and redo steps for each open image	Mark the <b>Limit undo/redo to</b> check box, and type or set a value in the control. The default is 250.
Make the redo process faster	Mark the <b>Enable fast redo</b> check box. This may slightly slow down the undo process, so if you rarely perform a redo, but use undo frequently, you may want to unmark this check box.
Set the number of non-undoable steps retained after the last non-undoable step limit has been reached	Type or set a value in the <b>Non-undoable steps in History Palette</b> control.

## Setting View preferences

The View settings lets you control some image window behaviors. You can choose how the image window and magnification level behave when you resize an image.

### To set View preferences

Edit workspace

Manage workspace

- 1 Choose **File ▶ Preferences ▶ General Program Preferences**.
- 2 From the left pane, choose **View**.
- 3 Perform one or more of the following tasks and click **OK**.

To	Do the following
Resize an image window when you zoom in	In the Zooming group box, mark the <b>Fit image to window when zooming in</b> check box. The image window resizes to include as much of the image as will fit.
Resize an image window when you zoom out	In the Zooming group box, mark the <b>Fit image to window when zooming out</b> check box. The image window resizes to include as much of the image as will fit.
Automatically reset the magnification level to display an entire image on opening	In the New images group box, mark the <b>Auto size</b> check box.
Automatically resize the image window when you resize an image	In the After changing size group box, mark the <b>Fit window to image</b> check box.
Automatically reset the magnification level to display an entire image after resizing	In the After changing size group box, mark the <b>Auto size</b> check box.

## Setting Display and Caching preferences

You can change the display options for certain parts of the program. For example, you can change the appearance of tool cursors, reset the scaling quality of the Zoom, and set thumbnail sizes for the Effects Browser. You can also specify preferences for saving an image cache and setting a scratch disk.

### Scratch disks

Setting a scratch disk (sometimes called a “swap disk”) enables the application to distribute operations across your main disk and a secondary disk. This extends the memory available to the application

when working on several large files at one time. Your best option is to choose a drive on a second internal hard disk (SCSI, SSD, IDE, SATA) that has more than 500 MB of free space. Avoid using the main drive where the application is installed if possible. Removable drives are not supported and the configuration of the drive determines if it is available as a scratch disk.

***Important!** If you set your main drive as a scratch disk, ensure that you have more than 2 GB of free disk space. On some systems, using the main drive for a scratch disk causes performance issues. Unmark the scratch disk check box if this occurs.*

## Display settings in Windows

The Display settings in Windows affect Corel PaintShop Pro and other applications on your computer system. Corel PaintShop Pro is optimized for the 100% display option in Windows. If you see text cut off or elements of the user interface cut off (truncated), please check your Display settings in Windows (**Control Panel ▶ Appearance and Personalization ▶ Display**).

## To set Display and Caching preferences

Edit workspace

Manage workspace

- 1 Choose **File ▶ Preferences ▶ General Program Preferences**.
- 2 From the left pane, choose **Display and Caching**.
- 3 Perform one or more of the following tasks, and click **OK**.

To

Do the following

---

Automatically use the last file format used to save an image

In the Presentation group box, mark the **Re-use last type in file save-as dialog** check box.

---

To	Do the following
Hide Dropper tool color information	In the Presentation group box, unmark the <b>Display all color dropper tooltips</b> check box.
Use a crosshair cursor for all tool cursors	In the Presentation group box, mark the <b>Use precise cursors</b> check box. A crosshair cursor is displayed instead of the tool button shape.
Make a brush tool cursor reflect its size and shape	In the Presentation group box, mark the <b>Show brush outlines</b> check box.
Determine the rescaling quality for the Zoom tool	Adjust the <b>Zoom / Rescaling Quality</b> slider.
Set thumbnail sizes for the Effect Browser	In the Effect browser thumbnails group box, set or type a value in the <b>Size (Pixels)</b> control.
Save an image cache of your entire merged image	In the <b>Caching</b> group box, mark the <b>Merged Image</b> check box.
Save an image cache of all the layers below the active one	In the <b>Caching</b> group box, mark the <b>Merged Below Active Layer</b> check box.
Save an image cache of the merged image for each group	In the <b>Caching</b> group box, mark the <b>Merged Group</b> check box.
Save an image cache of all the group layers below the active one	In the <b>Caching</b> group box, mark the <b>Merged Below Active Layer</b> check box.
Set a scratch disk	In the <b>Scratch disk</b> group box, mark the <b>Enable scratch disk</b> check box and choose a disk from the drop-list.

## Setting Palettes preferences

You can control the behavior of palettes, such as how palettes dock, as well as some properties of the Materials and Layers palettes. For more information about Layers palette settings, see “To modify the look of the Layers palette” on page 337.

### To set Palettes preferences

Edit workspace

Manage workspace

- 1 Choose **File** ▶ **Preferences** ▶ **General Program Preferences**.
- 2 From the left pane, choose **Palettes**.
- 3 Perform one or more of the following tasks, and click **OK**.

To	Do the following
Set the color mode in which to display color information	In the <b>Materials palette</b> group box, choose either the <b>Display colors in RGB format</b> option or <b>Display colors in HSL format</b> option. This determines how color information is displayed in the <b>Materials</b> palette and <b>Dropper</b> tool.
Set how color values are displayed in ToolTips or in a Color dialog box	In the <b>Materials palette</b> group box, choose either the <b>Decimal display</b> option or the <b>Hexadecimal display</b> option.
Set how paletted images display available colors in the Rainbow tab or in a Color dialog box	In the <b>Materials palette</b> group box, choose either <b>Show rainbow picker</b> or <b>Show document palette</b> . Note that this option only applies to images with 256 or fewer colors.
Show 16-bit color values in ToolTips	Mark the <b>Display 16-bit values</b> check box. Note that this option only applies to 16-bit images.

To	Do the following
Make palettes undockable	In the <b>Allow docking of</b> group box, unmark check boxes for the palettes you want to make undockable.
Set whether palettes appear automatically	<p>In the <b>Automatically show palettes</b> group box, choose one of the following:</p> <ul style="list-style-type: none"> <li>• <b>Always</b> — displays palettes appropriate to the tools and commands you are using. For example, if you perform a layers-related action, the Layers palette is displayed.</li> <li>• <b>Never</b> — displays palettes only when you choose to open them</li> <li>• <b>With Learning Center</b> — displays palettes appropriate to the topics accessed in the Learning Center palette. This is the default setting.</li> </ul>
Set display options for the Layers palette	<p>In the <b>Layers palette</b> group box, choose any of the following:</p> <ul style="list-style-type: none"> <li>• <b>Tooltip thumbnails</b> — sets the size at which a layer's thumbnail appears in the tooltip</li> <li>• <b>Palette thumbnails</b> — displays a layer's thumbnail within the palette. Mark this check box, and then set the desired size.</li> <li>• <b>Right pane</b> — displays a layer's settings on the right side of the palette</li> </ul>

## Setting Units preferences

You can set ruler options and the default resolutions for images that do not contain resolution information, such as scanned images.

### To set Units preferences

Edit workspace

Manage workspace

- 1 Choose **File** ▶ **Preferences** ▶ **General Program Preferences**.
- 2 From the left pane, choose **Units**.
- 3 Perform one or more of the following tasks, and click **OK**.

To	Do the following
Choose a unit of measurement for the rulers	In the Rulers group box, choose a unit of measurement option from the <b>Display units</b> drop-list.
Display rulers in black and white	In the Rulers group box, choose the <b>Black on White</b> option.
Display rulers in color	In the Rulers group box, choose the <b>Toolbar colors</b> option. The ruler color matches the toolbar color.
Snap vector objects to the pixel's center	In the Vector coordinates group box, mark the <b>Snap to center of pixel while moving</b> check box.
Set the default resolution for images that do not contain resolution information	In the Default Resolution group box, choose the unit of measure from the drop-list and enter a value in the control.

## Setting Transparency and Shading preferences

You can choose the grid size and color scheme. You can also choose a color and opacity for the shaded areas that falls outside of the selected area when using the Crop tool.

### To set Transparency preferences

Edit workspace

Manage workspace

- 1 Choose **File** ▶ **Preferences** ▶ **General Program Preferences**.
- 2 From the left pane, choose **Transparency and Shading**.
- 3 Perform one or more of the following tasks, and click **OK**.

To	Do the following
Customize grid colors	In the Grid group box, choose a color scheme from the <b>Scheme</b> drop-list, and click the color boxes to set the grid colors.
Set the grid size	In the Grid group box, choose a size option from the <b>Grid size</b> drop-list.

### To set Crop tool and Shading options

Edit workspace

Manage workspace

- 1 Choose **File** ▶ **Preferences** ▶ **General Program Preferences**.
- 2 From the left pane, choose **Transparency and Shading**.
- 3 In the Shading group box, mark the **Enable crop shade area** check box to activate shading outside the crop rectangle.
- 4 Click the **Color** box, and choose a shading area color.
- 5 Type or set a value in the **Opacity** control to set how opaque the shading area color is.
- 6 If you want the crop rectangle to appear every time you use the tool, mark the **Automatically display crop rectangle** check box.



- 7 If you want the floating crop toolbar to appear every time you use the tool, mark the **Enable floating crop toolbar** check box.

## Setting Warnings preferences

You can control how warning dialog boxes are displayed.

By default, Corel PaintShop Pro displays a warning dialog box whenever you are about to perform an operation that will result in the loss of information or one that cannot be applied to the image in its current state.

### To set Warnings preferences

Edit workspace

Manage workspace

- 1 Choose **File** ▶ **Preferences** ▶ **General Program Preferences**.
- 2 From the left pane, choose **Warnings**.
- 3 Perform one or more of the following tasks, and click **OK**.

To

Do the following

---

Prevent a specific warning from appearing

Unmark the check box beside the warning description.

---

Prevent all warnings from appearing Click **Disable All**.

---

## Setting Auto Action preferences

You can automate actions that must be performed in order to further edit an image.

For example, some commands can be performed only on images with a bit depth of at least 8 bits per pixel. When you choose a command for an image with a bit depth lower than 8 bits per pixel, the Auto Actions dialog box appears with the message that the image must be

converted to a higher bit depth in order to proceed with the command.

## To set Auto Action preferences

Edit workspace

Manage workspace

- 1 Choose **File** ▶ **Preferences** ▶ **General Program Preferences**.
- 2 From the left pane, choose **Auto Action**.
- 3 Select an action from the **Auto Action Prompt** list, and choose one of the following options:
  - **Never** — prevents the action from happening

**Note:** Choosing **Never** makes certain menu commands inactive if the action is required to complete the command. Some items in the list do not have this option available.

  - **Always** — performs the action silently without prompting you
  - **Prompt** — asks if you want to perform the action
- 4 Click **OK**.



You can set all actions in the list to a certain option by clicking **Always All**, **Prompt All**, or **Never All**.

You can reset all the actions in the list to the default settings by clicking **Reset**.

## Setting Miscellaneous preferences

You can control a variety of preferences on the Miscellaneous page of the Preferences dialog box.

## To set the number of files that appear in the Recent Files list

Edit workspace

Manage workspace

- 1 Choose **File** ▶ **Preferences** ▶ **General Program Preferences**.

- 2 From the left pane, choose **Miscellaneous**.
- 3 Type or set a value in the **Recently used file list** control.



You must restart Corel PaintShop Pro before the new settings take effect.



You can view the list by choosing **File ▶ Recent Files**.

## To set tolerance to background color when pasting a transparent selection

Edit workspace

Manage workspace

- 1 Choose **File ▶ Preferences ▶ General Program Preferences**.
- 2 From the left pane, choose **Miscellaneous**.
- 3 Type or set a value in the **Tolerance to background color when pasting a transparent selection** control.



When you paste data as a transparent selection, Corel PaintShop Pro adds it to the current image, defines it as a selection, and deselects all the pixels that match the current background color. The tolerance value you enter determines how closely the background color must match the transparent color for it to become transparent. The tolerance scale is 0% (only image pixels with a perfect match to the current background color are made transparent) to 100% (all image pixels are made transparent).

## To set Clipboard data preferences

Edit workspace

Manage workspace

- 1 Choose **File ▶ Preferences ▶ General Program Preferences**.
- 2 From the left pane, choose **Miscellaneous**.

- 3 From the **Clipboard data on Exit** list, choose an option to determine how any information on the Clipboard is handled when you exit the program:
  - **Ask** — asks what you want to do with the Clipboard data
  - **Delete** — deletes Clipboard data when you exit the program
  - **Leave** — leaves data in the Clipboard when you exit the program

## To redraw when you move an object

Edit workspace

Manage workspace

- 1 Choose **File ▶ Preferences ▶ General Program Preferences**.
- 2 From the left pane, choose **Miscellaneous**.
- 3 Mark the **Force full window redraw when positioning image elements** check box.

The information in the active window is redrawn whenever you move objects in the image.

## To hide the program splash screen on startup

Edit workspace

Manage workspace

- 1 Choose **File ▶ Preferences ▶ General Program Preferences**.
- 2 From the left pane, choose **Miscellaneous**.
- 3 Unmark the **Show splash screen when application starts** check box.

## To disable pressure support for puck-type pointing devices

Edit workspace

Manage workspace

- 1 Choose **File ▶ Preferences ▶ General Program Preferences**.
- 2 From the left pane, choose **Miscellaneous**.

- 3 Mark the **Disable pressure support for puck-type pointing devices** check box.

## To enable preservation of brightness in resized images

Edit workspace

Manage workspace

- 1 Choose **File ▶ Preferences ▶ General Program Preferences**.
- 2 From the left pane, choose **Miscellaneous**.
- 3 Mark the **Preserve image brightness when resizing** check box.



When this option is enabled, a resized image retains its overall perceived brightness. In certain cases, however, unmarking this check box may produce better results — for example, when you are reducing the size of a computer-generated image, such as a scanned line drawing.

## Setting Manage workspace preferences

You can set controls for how image thumbnails appear in the Manage workspace, and you can specify formats and folders to exclude from viewing within the Manage workspace.

## To set Manage workspace preferences

Edit workspace

Manage workspace

- 1 Choose **File ▶ Preferences ▶ General Program Preferences**.
- 2 Click **Manage** in the list of categories on the left.
- 3 Perform one or more of the following tasks and click **OK**.

To

Do the following

---

Show photo ratings on thumbnails	In the <b>Thumbnail images</b> group box, mark the <b>Show ratings with thumbnail images</b> check box.
----------------------------------	---

---

To	Do the following
Show the image filename on thumbnails	In the <b>Thumbnail images</b> group box, mark the <b>Show file name with thumbnail images</b> check box.
Exclude specific file formats from appearing in the Manage workspace	In the <b>Excluded items</b> group box, click the <b>File format exclusions</b> button. From the left side of the File Format Exclusions dialog box, mark the check boxes of the file formats you want to exclude. To mark all formats simultaneously, click <b>Select All</b> . To remove the check marks from all selected formats, click <b>Remove All</b> .
Specify folders to exclude from cataloging	In the <b>Excluded items</b> group box, click the <b>Uncataloged Folders</b> button. The Uncataloged Folders dialog box lists the folders that are currently not cataloged in the Manage workspace. To add a folder to this list, click <b>Add</b> , and then use the Browse for Folder dialog box to select the folder. To allow a currently ignored folder to be cataloged, select the folder from the list, and click <b>Delete</b> . To reset the list of ignored folders to the default list, click the <b>Reset to Default</b> button.



You can also open the Preferences dialog box by right-clicking anywhere inside the Thumbnails panel of the Organizer, and choosing **Preferences** from the context menu.

## Setting Auto-Preserve preferences

You can set the program to always save a copy of your original (unedited) images in a clearly labeled backup folder. This feature essentially creates “digital negatives,” which can be accessed whenever you want to work with images in their original state.

### To set Auto-Preserve preferences

Edit workspace

Manage workspace

- 1 Choose **File** ▶ **Preferences** ▶ **General Program Preferences**.
- 2 From the left pane, choose **Auto-Preserve**.
- 3 Mark the **Enable Auto-Preserve** check box.
- 4 Click **OK**.

#### To

#### Do the following

---

Create copies of original images automatically when you first save them

In the dialog box that appears after you click **Save**, choose **Yes - Do this every time**. The original (unedited) image is copied to a Corel Auto-Preserve subfolder, which is automatically created within the folder in which you are saving the image.

---

Reopen the original image

In the Open dialog box or the Navigation palette to browse to the Corel Auto-Preserve subfolder that contains a copy of the original image. The Corel Auto-Preserve subfolder resides within the same folder in which original image was first saved.

---

To	Do the following
Avoid creating copies of original images	In the dialog box that appears after you click Save, choose <b>No - Save my images without preserving the original</b> .

---

## Choosing a default workspace

When you open the program, the Organizer is your default workspace from which you can access the Express Lab or the Full Editor. If your digital workflow requires a different workspace upon program launch, you can change the default settings.

### To choose a workspace upon program launch

Edit workspace

Manage workspace

- 1 Choose **File** ▶ **Preferences** ▶ **General Program Preferences**.

The Preferences dialog box appears.

- 2 Click **Default Launch Workspace** in the list of categories on the left.
- 3 Enable one of the following options, and click **OK**.
  - **Manage** — displays the Manage workspace when you launch the program
  - **Edit** — displays the Edit workspace when you launch the program
  - **Keep Last View** — displays the workspace you used before you closed the program in your last Corel PaintShop Pro session

## Setting file format preferences

In the File Format Preferences dialog box you can specify how Corel PaintShop Pro handles images in the following formats:



- General — this tab lets you set options for RAW camera images.
- Windows Metafile — WMF is the Microsoft Windows native vector format.
- Kodak Photo CD — PCD is used by many photo developers. This format can provide multiple image resolutions in one file.
- Portable Network Graphics — PNG is used for Web graphics. You can set preferences for opening and saving PNG files.
- PostScript — Corel PaintShop Pro can read PostScript files (including multi-page files) through level 2 and open them as raster images. When converting, Corel PaintShop Pro can anti-alias objects and retain transparency information.
- RAW Graphics — Corel PaintShop Pro can read and save RAW graphics image formats. This format (which is not to be confused with RAW Camera Data images) is commonly used in graphics images in the scientific and computer gaming industries.

For a full list of supported file formats, see “Files supported by Corel PaintShop Pro” on page 94.

### **What’s the difference between RAW camera data images and RAW (Graphics) file format images?**

RAW camera data images contain unprocessed sensor data captured by high-end digital cameras from Canon, Fuji, Kodak, Minolta, Nikon, Olympus, and Pentax. The data from these images in no way resembles or responds like RAW graphics image data.

RAW graphics images are basic raster data format images with no compression, and may include an optional non-standard header which is not supported by Corel PaintShop Pro. These graphics images are used primarily by game developers and by the scientific community. Game developers use RAW graphics images for custom image

texturing, bumpmapping, and shading. The scientific community uses these images for custom application-based image analysis.

Corel PaintShop Pro can create and edit RAW graphics images as well as provide conversion from standard formats (such as TIF, JPEG, or TGA) into the RAW graphics format.

You can correct the tint, or color cast, certain types of lighting may cause. For example, if the photo was shot indoors in fluorescent lighting, and the camera was set for outdoor lighting conditions, the photo may have a green color cast. In this case, you can choose an option that applies correction for a photo taken in fluorescent light.

## To set General image preferences

Edit workspace

Manage workspace

- 1 Choose **File** ▶ **Preferences** ▶ **File Format Preferences**.

The File Format Preferences dialog box appears.

- 2 Click the **General** tab.
- 3 Mark the **Open RAW images with Camera RAW Lab** check box to automatically display this command dialog box on opening a RAW camera image.

## To set WMF image preferences

Edit workspace

Manage workspace

- 1 Choose **File** ▶ **Preferences** ▶ **File Format Preferences**.

The File Format Preferences dialog box appears.

- 2 Click the **Metafile / Import** tab.
- 3 In the **Load options** group box, choose one of the following options:
  - **Prompt for size and options each time a file is opened** — prompts you to choose settings for each WMF image you open

- **Use file header information when available** — uses the file header default size. If you open a file without a header, the size defaults to the values you type in the **Default size when file header is not available** group box.

4 Click **OK**.

### You can also

---

Import WMF vector data as objects you can edit with vector tools    Mark the **Import vector data** check box.

---

Smooth curved polylines (vector data only)    Mark the **Apply smoothing** check box.

---

## To set PCD file format preferences

Edit workspace

Manage workspace

1 Choose **File ▶ Preferences ▶ File Format Preferences**.

The File Format Preferences dialog box appears.

2 Click the **PCD** tab.

3 Choose one of the following resolution settings:

- **96 × 64**
- **192 × 128**
- **384 × 256**
- **768 × 512**
- **1536 × 1024**
- **3072 × 2048**
- **6144 × 4096**

4 Click **OK**.



You can have Corel PaintShop Pro ask you to pick a resolution each time you open a PCD file by choosing the **Ask when loading each file** option.

## To set PNG preferences

Edit workspace

Manage workspace

- 1 Choose **File** ▶ **Preferences** ▶ **File Format Preferences**.

The File Format Preferences dialog box appears.

- 2 Click the **PNG** tab.
- 3 Choose one of the following options:
  - **Load and Save transparency to/from layer transparency**
  - **Load and Save transparency to/from alpha channel**

## To set PostScript file import preferences

Edit workspace

Manage workspace

- 1 Choose **File** ▶ **Preferences** ▶ **File Format Preferences**.

The File Format Preferences dialog box appears.

- 2 Click the **PostScript** tab.
- 3 Unmark the **Prompt for size and options each time a PostScript file is opened** check box.
- 4 Set or type a value in the **Resolution** control.
- 5 Choose a page size option from the **Page size** drop-list.
- 6 Choose an image mode option from the **Image mode** drop-list.
- 7 Click **OK**.

## You can also

Choose to be prompted to set options every time you open a PostScript file	Mark the <b>Prompt for size and options each time a PostScript file is opened</b> check box.
Switch the page orientation to landscape	Mark the <b>Landscape</b> check box.
Anti-alias PostScript objects as they are converted to raster images	Mark the <b>Anti-aliasing</b> check box.
Use a white background instead of the default transparent background	Mark the <b>Render transparency</b> check box



By default, if a PostScript file has a bounding box, the program matches the canvas size to the bounding box.

## To set RAW file preferences

Edit workspace

Manage workspace

- 1 Choose **File ▶ Preferences ▶ File Format Preferences**.

The File Format Preferences dialog box appears.

- 2 Click the **RAW (Graphics)** tab.
- 3 In the **Save options** group box, type or set a value in the **Header size** control to set the header size of the file.
- 4 In the **24 bit options** group box, choose one of the following color order options:
  - **RGB order**
  - **BGR order**
- 5 Choose one of the following color order options:
  - **Planar mode** — stores the color data in separate 8-bit planes
  - **Interleaved** — stores pixels contiguously



You can flip the image upside down by marking the **Flip top and bottom** check box.

## Setting file format associations

File format associations control how Corel PaintShop Pro interacts with many types of file formats. For a full list of supported file formats, see “Files supported by Corel PaintShop Pro” on page 94.

### Adding and removing file format associations

You can have certain file formats automatically open in Corel PaintShop Pro. For example, when you associate the JPEG file format with Corel PaintShop Pro, all JPEG files open in Corel PaintShop Pro when you double-click them from the Windows desktop. The associated JPEG files also display Corel PaintShop Pro icons.

### Changing file format extensions

File format extension changes do not take effect until the next time you start Corel PaintShop Pro. File extensions that have been associated with Corel PaintShop Pro will have an asterisk (\*) after the name.

### What if I want to open a file in another program?

When you associate a file format with Corel PaintShop Pro, you can still open the file in other programs by using the Open command in the program of your choice.

## To associate a file format with Corel PaintShop Pro

Edit workspace

Manage workspace

- 1 Choose **File** ▶ **Preferences** ▶ **File Format Associations**.

The Windows Set associations for a program page appears.

- 2 Mark the check boxes for the options you want.
- 3 Click **Save**.

## Setting file locations

Corel PaintShop Pro resources include such items as scripts, picture tubes, patterns, gradients, displacement maps, and workspaces. The full listing of resources is displayed along the left side of the File Locations dialog box. Corel PaintShop Pro saves and searches for resources in several default folders on your computer. By changing File Locations preferences, you can change where Corel PaintShop Pro looks for and saves these resources. You can also control how plug-ins are used and which Web browsers are used to preview your images.

By default, all new files you create are saved in the appropriate subfolder in the ...Documents\Corel PaintShop Pro\17.0 folder. Most default program resources are stored in the appropriate folder in the path X:\Program Files(x86)\Corel\Corel PaintShop Pro X7 for 32-bit and X:\Program Files\Corel\Corel PaintShop Pro X7 (64-bit) for 64-bit, where “X” indicates the drive on which Corel PaintShop Pro is installed.

You can add or delete folders for Corel PaintShop Pro to store and retrieve the various resources. Deleting a folder means that Corel PaintShop Pro no longer looks in the folder for any items. The folder, however, is not deleted from your computer.

You can also change the file location for specific resources.

### To change file locations for resources

Edit workspace

Manage workspace

- 1 Choose **File ▶ Preferences ▶ File Locations**.

The File Locations dialog box appears.

- 2 From the File types list, select the resource that you want to change file locations for.

The default folders where the specified resource can be saved to are listed on the right side of the dialog box.

- 3 Click **Add**.

The Browse Folder dialog box appears.

- 4 Navigate to the folder you want to add, and click **OK**.

- 5 In the **Folder options** group box, mark the **Enable** check box.

If you want to enable the folder's subfolders, mark the **Use sub folders** check box.

**Note:** When these check boxes are unmarked, Corel PaintShop Pro cannot search for folders and their subfolders.

- 6 From the Save to drop-list, choose the folder in which you want the current resource saved.

- 7 Click **OK** to save your settings and return to Corel PaintShop Pro.



You can open the File Locations dialog box by clicking the **File Locations** button , which appears in many Corel PaintShop Pro dialog boxes.

## To add file locations for resources

Edit workspace

Manage workspace

- 1 Choose **File** ▶ **Preferences** ▶ **File Locations**.

The File Locations dialog box appears.

- 2 From the **File types** list, select the resource file type for which you want to add locations.

- 3 Click **Add**.

The Browse for Folder dialog box appears.



- 4 Click the **Create a New Folder** button and then enter the name for the new folder.
- 5 Click **OK** to add the new folder to the list.
- 6 Click **OK** to close the File Locations dialog box.



The Cache and CMYK Profiles resource file types can have only one location. You can only change the file location from one folder to another. For more information on changing file locations, see “Setting file locations” on page 691.



You can open the File Locations dialog box by clicking the **File Locations** button , which appears in many Corel PaintShop Pro dialog boxes.

## To delete file locations for resources

Edit workspace

Manage workspace

- 1 Choose **File ▶ Preferences ▶ File Locations**.

The File Locations dialog box appears.

- 2 From the **File types** list, select the resource file type that you want to delete file locations for.
- 3 In the list of folders, select the folder you want to delete.
- 4 Click **Remove**.
- 5 Click **OK**.



You can open the File Locations dialog box by clicking the **File Locations** button , which appears in many Corel PaintShop Pro dialog boxes, as well as in the Presets drop-list (located in the Tool Options palette) for tools.

## Managing resources

Corel PaintShop Pro resources include such items as scripts, picture tubes, patterns, gradients, displacement maps, and workspaces. The full listing of resources is displayed along the left side of the File Locations dialog box. Using a consistent method for managing these resources can make your workflow easier. This is where the Resource Manager dialog box comes in.

Wherever you find a Presets control, such as in the Tool Options palette, or in the Presets drop-list in an effects dialog box, you can access the Resource Manager dialog box.

You can delete, rename, copy, and move resources. You can also create your own resource categories.

### To access the Resource Manager dialog box

Edit workspace

- Click a Presets control, and click the **Resource Manager** button .

### To delete a resource

Edit workspace

- 1 Click a Presets control, and click the **Resource Manager** button .
- 2 If necessary, from the **Category** drop-list choose the category where the resource resides.
- 3 Click the resource from the list.
- 4 Click **Delete**.

### To rename a resource

Edit workspace

- 1 Click a Presets control, and click the **Resource Manager** button .
- 2 If necessary, from the **Category** drop-list choose the category where the resource resides.

- 3 Click the resource from the list.
- 4 Click **Rename**.  
The Rename Resource dialog box appears.
- 5 Type the new name for the resource, and click **OK**.

## To copy a resource to another location

Edit workspace

- 1 Click a Presets control, and click the **Resource Manager** button .
- 2 If necessary, from the **Category** drop-list choose the category where the resource resides.
- 3 Click the resource from the list.
- 4 Click **Copy**.  
The Save As dialog box appears.  
**Note:** At this point, you can also rename the file by typing a new name in the **File Name** field.
- 5 Navigate to the folder where you want to move the resource and click **Save**.

**Note:** You cannot copy a resource without renaming it to a folder currently being scanned using the File Locations dialog box.

## To move a resource to another location

Edit workspace

- 1 Click a Presets control, and click the **Resource Manager** button .
- 2 If necessary, from the **Category** drop-list choose the category where the resource resides.
- 3 Click the resource from the list.
- 4 Click **Move**.  
The Browse for Folder dialog box appears.
- 5 Navigate to the folder where you want to move the resource, and then click **OK**.

**Note:** The folder to which you move the resource must be listed in the File Locations dialog box for the resource to appear in the visual resource drop-list and in the Resource Manager dialog box. For information about setting file locations, see “Setting file locations” on page 691.

## To create a resource category

Edit workspace

Manage workspace

- 1 Choose **File** ▶ **Preferences** ▶ **File Locations**.

The File Locations dialog box appears.

- 2 In the File types list on the left side of the dialog box, click the resource for which you want to create a new category folder.
- 3 In the folders list, click the folder under which the custom category subfolder will reside.
- 4 In the Folder Options group box, mark the **Enable** and **Use sub folders** check boxes.
- 5 Click **Create Sub Folder**.

The Enter Name dialog box appears.

- 6 Type a name for the custom category subfolder, and click **OK** to close the Enter Name dialog box.
- 7 Click **OK**.



To have the new category appear in the Categories drop-list, you must first save, copy, or move a resource to the folder you created.

## Setting plug-in preferences

With Corel PaintShop Pro, you can use plug-ins that provide compatibility with Adobe Photoshop files. The most common plug-in filename extension is **.8B\***. You can choose to limit the use of plug-ins

to those having the **.8B\*** filename extension, or you can choose to use plug-ins having any filename extension.

## To enable plug-ins

Edit workspace

Manage workspace

- 1 Choose **File ▶ Preferences ▶ File Locations**.

The File Locations dialog box appears.

- 2 From the File types list, select **Plug-ins**.
- 3 Mark the **Enable plug-ins** check box.

## You can also

---

Load plug-ins with any extension	Unmark the <b>Limit Loaded plug-in files to those with an .8B* extension</b> check box.
Open the file in the plug-in before it opens in Corel PaintShop Pro	Mark the <b>Allow file format plug-ins to request pre-filtering of support file types</b> check box.

---

## To add plug-in locations

Edit workspace

Manage workspace

- 1 Choose **File ▶ Preferences ▶ File Locations**.

The File Locations dialog box appears.

- 2 From the File types list, select **Plug-ins**.
- 3 Click **Add**.

A new blank item appears in the folder list, and the Browse for Folder dialog box appears.

- 4 Navigate to the folder you want to add, and click **OK** to return to the File Locations dialog box.
- 5 In the Folder options dialog box, mark the **Enable** check box.
- 6 Click **OK**.



You can also add any subfolders stored in the plug-in folder you add by marking the **Use sub folders** check box.

## Selecting Web browsers

Corel PaintShop Pro lets you preview your images with Web browsers. You can add, change, or delete Web browsers.

### To add Web browsers

Edit workspace

Manage workspace

- 1 Choose **File** ▶ **Preferences** ▶ **File Locations**.

The File Locations dialog box appears.

- 2 From the File types list, select **Web Browsers**.

- 3 Click **Add**.

The Browser Information dialog box appears.

- 4 Click **Browse**.

The Web Browser Path dialog box appears.

- 5 Navigate to the folder containing the Web browser executable file (with the filename extension **.exe**), and click **Open**.

- 6 Click **OK**.

### To change Web browsers

Edit workspace

Manage workspace

- 1 Choose **File** ▶ **Preferences** ▶ **File Locations**.

The File Locations dialog box appears.

- 2 From the File types list, select **Web Browsers**.

- 3 Select a browser from the list.

- 4 Click **Edit**.

The Browser Information dialog box appears.

- 5 Click **Browse**.

The Web Browser Path dialog box appears.

- 6 Navigate to the folder containing the Web browser executable file (with the filename extension **.exe**), and click **Open**.
- 7 Click **OK**.

## To delete Web browsers

Edit workspace

Manage workspace

- 1 Choose **File ▶ Preferences ▶ File Locations**.

The File Locations dialog box appears.

- 2 From the File types list, select **Web Browsers**.
- 3 Select a browser from the list.
- 4 Click **Delete** to remove the browser from the list.
- 5 Click **OK**.

## Setting Autosave preferences

Corel PaintShop Pro lets you automatically save your work as you move between tasks. For example, if you make some edits in the **Adjust** workspace, and switch to another photo or workspace, your changes will be applied automatically.

It is recommended that you enable **Auto-Preserve** if you enable **Autosave**. For more information, see “Setting Auto-Preserve preferences” on page 683.

## To set the autosave preferences

Edit workspace

Manage workspace

- 1 Choose **File ▶ Preferences ▶ Autosave Settings**.

The **Autosave Settings** dialog box appears.

- To enable **Autosave**, do any of the following:
  - Click the **Adjust workspace** tab and mark the **Save edits to the current image automatically when the next image is selected** check box.
  - Click the **Edit workspace** tab and mark the **Automatically save backup copies of all open files every \_\_ minutes** check box. Type or set a value in the minutes control.
- Click **OK**.



To find out where Corel PaintShop Pro saves the autosaved files, choose **File ▶ Preferences ▶ File Locations** and select the **Undo/Temporary Files** folder from the **File Type** list.

## Resetting all preferences

You can revert various program preferences back to their defaults.

### To reset application preferences

Edit workspace

Manage workspace

- Choose **File ▶ Preferences ▶ Reset Preferences**.

The **Reset the Application** dialog box appears.
- Mark any of the following check boxes:
  - Reset general preferences** — resets all general program preference settings to the program defaults
  - Reset file locations** — resets all file location settings to the program defaults
  - Reset workspace to default configuration** — resets the current workspace to the program defaults



- **Reset dialog box positions and last used settings** — resets dialog boxes so they appear in their default positions and use default settings
- **Delete all cache files** — deletes all existing cache files
- **Make all toolbars/palettes visible and on screen** — makes all toolbars and palettes visible

3 Click **OK**.



You can reset the entire application to its default state by holding down **Shift** while launching the program. All customization is cleared when you reset the program.

## Switching languages

You can change the language that is displayed in Corel PaintShop Pro. This option can be helpful for international or multilingual users, or for users sharing a workstation in an international corporate environment.

### To switch the application language

Edit workspace

Manage workspace

1 Choose **File ▶ Preferences ▶ Switch Language**.

The Switch Language dialog box appears.

2 Select the desired language from the drop-list.

**Note:** This feature does not support switching between languages with single-byte character sets (such as English, German, and French) and languages with double-byte character sets (such as Chinese Simplified, Chinese Traditional, and Japanese).

3 Click **OK**.

4 In the message box that notifies you to restart the application, click **OK**.

The selected language is displayed after the application is restarted.

## Adjusting general viewing options

You can customize how Corel PaintShop Pro displays icons, screen tips, and captions.

### To set toolbar view options

Edit workspace

- 1 Choose **View ▶ Customize**.

The Customize dialog box appears.

- 2 Click the **Options** tab.
- 3 In the Toolbar area, mark any of the following check boxes:
  - **Show ScreenTips on toolbars** — displays the screen tips that appear over tools and buttons
  - **Show shortcut keys in ScreenTips** — displays the shortcut keys (if available) that appear in screen tips
- 4 In the Icons area, mark any of the following check boxes:
  - **Show color icons** — mark to show color icons; unmark to show grayscale icons
  - **Show small icons** — mark to decrease the size of the icons; unmark to display the icons at the default size
- 5 In the Personalized Menus and Toolbars group box, mark any of the following check boxes:
  - **Menus show recently used commands first** — simplifies menus to show only recently used commands
  - **Show full menus after a short delay** — displays all menu items after a delay if the **Menus show recently used commands first** check box is marked



You can erase the memory of your recently used menu commands by clicking **Reset my usage data**.

## Accessing tools and commands from previous versions of Corel PaintShop Pro

You can access and restore tools and commands that have been removed from the workspace. These commands were removed to accommodate improved features and functionality.

### To access tools and commands from previous versions of Corel PaintShop Pro

Edit workspace

- 1 Choose **View** ▶ **Customize**.

The Customize dialog box appears.

- 2 In the **Commands** tab, perform a task from the following table and click **Close**.

To	Do the following
Add commands	In the Categories list, click <b>Unused Commands</b> , find the command you want, and drag it to a menu.
Add tools	In the Categories list, click <b>Tools</b> , choose the tool you want, and drag it to the Tools toolbar.

## Protecting and restoring the Corel PaintShop Pro database

The database for your application stores information about your photo library and makes it easier to search for photos. If the database is damaged, it can affect the performance of Corel PaintShop Pro. Please

note that your photos are safe, but a damaged database can result in the loss of customized photo data, such as ratings, tags, and caption text.

To protect your database, you can create a backup file. In the event the database is damaged, you can reset the database and import your backup file.

Please note, JPEG photo data from Corel PaintShop Photo Pro X5 is imported into the X7 database when you browse folders. For more information about browsing folders, see “Getting photos into Corel PaintShop Pro” on page 60.

### To backup the application database

- 1 Save your work.
- 2 Click **File ▶ Database Backup ▶ Export**.

You will be prompted to close the application. A backup database file is created. Restart the application.

### To reset the application database

- 1 Ensure that the application is closed.
- 2 From the Windows Start menu, choose **All Programs ▶ Corel PaintShop Pro ▶ Restore Database**.

### To import your application database backup

- 1 Save any open work.
- 2 Click **File ▶ Database Backup ▶ Import**.

You will be prompted to close the application. The backup database file is imported when you restart the application.



Corel PaintShop Pro has many time-saving automation features. You can use scripts to automate an action or set of actions, and presets to save dialog box or tool settings for later use. You can also perform the same action to a number of images at the same time.

This section presents the following topics:

- Scripting basics
- Working with scripting tools and features
- Recording and saving a script
- Running saved scripts
- Stopping or undoing a script
- Editing scripts in Corel PaintShop Pro
- Editing scripts using a text-editing application
- Troubleshooting a script
- Assigning icons to scripts
- Using and creating presets
- Processing files in batches
- Renaming files in batches

## Scripting basics

Scripts are a series of commands that you record and play back. This can be a great time-saver, because instead of having to make the

changes to each image, you simply have to play back the script. The commands you recorded in the script are performed on the image.

Corel PaintShop Pro has a full-featured scripting engine based on the Python programming language. You can get more information on this language at [www.python.org](http://www.python.org). Although you can write your own scripts using Python syntax, Corel PaintShop Pro has a built-in script recorder that can do this work for you, allowing you to script almost any action within the application.

If, however, you choose to write a script in the Python language, note that Python uses indentation to determine scoping, so you must be very careful about mixing spaces and tabs. We recommend that you use a Python-aware editor such as PythonWin or Idle if you choose to write your own scripts.

## Scripting resources







Corel PaintShop Pro provides the following scripting resources:

- **Command API** — an HTML-based resource that helps you add Corel PaintShop Pro commands and parameters to the scripts that you write.
- **Scripting Guide** — a PDF guide that provides information about scripting for Corel PaintShop Pro. Definitions, example scripts, and command and parameter information helps you become familiar with scripting. (Available to all Members as a download ([Help ► Your Account](#))).
- **Sample scripts** — referenced in the Scripting Guide, the sample scripts are provided to give you some examples that you can learn from and build on.

## Working with scripting tools and features

You can find most scripting commands both in the **File ▶ Script** submenu and on the **Script** toolbar. You'll find it much easier and faster working with scripts using the Script toolbar. Some commands, however, are accessible only using the menu.

The following table describes the buttons on the Script toolbar.

Tool	Description
	The <b>Select Script</b> drop-list lets you choose the scripts saved in the <b>Scripts-Trusted</b> and <b>Scripts-Restricted</b> folders.
	The <b>Run Selected Script</b> button lets you run the script displayed in the <b>Select Script</b> drop-list.
	The <b>Run Multiple Scripts</b> button opens the Run Multiple Scripts dialog box so you can choose scripts from a list and run them in sequence.
	The <b>Edit Selected Script</b> button opens the Script Editor so you can edit the script displayed in the <b>Select Script</b> drop-list.
	The <b>Toggle Execution Mode</b> button lets you switch between Silent and Interactive mode when running scripts. When the button shows a border, it is set to Interactive mode.
	The <b>Run Script</b> button lets you navigate to and select the script you want to load.

Tool	Description
	The <b>Stop Script</b> button lets you stop the running script.
	The <b>Start Script Recording</b> button lets you begin recording actions that will comprise a script.
	The <b>Pause Script Recording</b> button lets you pause the recording of a script. You can click it again to resume recording.
	The <b>Cancel Script Recording</b> button lets you cancel script recording.
	The <b>Save Script Recording</b> button lets you stop recording a script and prompts you to save it.

## To display the Script toolbar

Edit workspace

- Choose **View ▶ Toolbars ▶ Script**.

## To access a script command from a menu

Edit workspace

- Choose **File ▶ Script**, and choose a script command.



You can only choose the **Clear Output Window** and **Single Step** commands from the menu. You can, however, add those commands to the Script toolbar. For more information, see “Customizing toolbars” on page 663.

## To display the Script Output palette

Edit workspace

- Choose **View ▶ Palettes ▶ Script Output**.





The Script Output palette displays information such as previously-used commands, Python syntax errors, or runtime errors.

## To clear the Script Output palette

Edit workspace

- Choose **File ▶ Script ▶ Clear Output Window**.



You can also clear a script by right-clicking the **Script Output** palette, and choosing **Clear** from the context menu.

## Recording and saving a script

Scripts are particularly useful for tasks with many steps. Most actions you can perform in Corel PaintShop Pro are scriptable; however, be aware of the following guidelines:

- You cannot script user interface customizations, CMYK profile creation or editing, operations inside the Manage workspace, operations inside of Print Layout, or gradient creation.
- You cannot script the floating, docking, or arranging of toolbars, palettes, and windows.
- You can script Materials palette and Mixer palette operations, as well as Tool Options palette selections, but you cannot record them. To script these actions, you must use a text editor application.
- Only plug-ins that support scripting are scriptable.
- Outside of the above restrictions, most actions you perform in Corel PaintShop Pro are scriptable.

Before you start recording a script, it's a good idea to write down the specific actions you want to record. Ideally, your actions should be as efficient as possible.

## Restricted and trusted scripts

The scripts in Corel PaintShop Pro are created in the Python programming language, which can unfortunately also be used to create and execute malicious scripts. Because of this potential danger, Corel PaintShop Pro includes two folders, automatically created in two locations during installation, each folder containing script files of distinct modes. These folders are

- **Scripts-Restricted** — contains scripts that do not reside in a trusted folder
- **Scripts-Trusted** — contains any trusted scripts

These folders reside inside the following paths:

- 32-bit — **X:\Program Files (x86)\Corel\Corel PaintShop Pro X7\Languages\[language code]** (where "x" indicates the drive on which you installed Corel PaintShop Pro)
- 64-bit — **X:\Program Files\Corel\Corel PaintShop Pro X7 (64-bit)\Languages\[language code]**
- In your user folder, **...Documents\Corel PaintShop Pro\17.0**

When you create and save a script for the first time, you're directed to save the script in the appropriate path in ...Documents\Corel PaintShop Pro\17.0. After that, you'll be directed to save to the most recently used folder.

When the application searches for scripts, restricted scripts are searched before trusted scripts.

Here are some considerations about restricted scripts:

- If a script is run from an unconfigured path, it is treated as restricted.
- If a path appears in both the restricted and trusted lists, it is treated as restricted.
- Presets, Material palette swatches, and Print Layout templates (which are essentially scripts) are treated as restricted.

### Commands that cannot be used in a restricted script



Some commands cannot be run from a script stored in the Scripts-Restricted folder. The table below lists a number of these commands. If you want to run a script that contains any of these commands, you must move it to the Scripts-Trusted folder.

Command	Menu location
FileSave	File ▶ Save
FileSaveAs	File ▶ Save As
FileSaveCopyAs	File ▶ Save Copy As
GIFExport	File ▶ Export ▶ GIF Optimizer
PNGExport	File ▶ Export ▶ PNG Optimizer
JPEGExport	File ▶ Export ▶ JPEG Optimizer
FileLocations	File ▶ Preferences ▶ File Locations
FileClose	File ▶ Close
FileCloseAll	File ▶ Close All
FileSend	File ▶ Send
BatchConvert	File ▶ Batch ▶ Process
BatchRename	File ▶ Batch ▶ Rename
Mapper	File ▶ Export ▶ Image Mapper
Slicer	File ▶ Export ▶ Image Slicer

Command	Menu location
FileExit	File ► Exit

## To record and save a script

Edit workspace

- 1 Click the **Start Script Recording** button .
- 2 Perform the actions that comprise the script.
- 3 Click the **Save Script Recording** button .  
The Save As dialog box appears.
- 4 Choose the folder where you want to store the script.
- 5 Type a name for the script, and click **Save**.

## You can also

Remove any undone commands from a script	In the Save As dialog box, mark the <b>Remove Undone Commands</b> check box.
Save Materials palette settings used by actions with a tool in a script	In the Save As dialog box, mark the <b>Save Materials</b> check box. If this check box is cleared, the current material is used with the given tool when the script is run, rather than the material that was used when the script was recorded. This option only applies to recorded actions with a tool, not with a material setting in a dialog box.

## You can also

---

Display interactive dialog boxes in their position during recording

In the Save As dialog box, mark the **Save Dialog Positions** check box. You may not want to use this option if you intend to share the script with others. Enabling this check box not only records the dialog position, but whether the Before/After preview area is displayed, whether the dialog is maximized, and whether the **Preview on Image** check box is marked. You can leave these preferences up to other users of your script.

---

Add descriptive information to a script

In the Save As dialog box, click **Description**, and type information in the **Author**, **Copyright**, and **Description** boxes. The information you enter is displayed when you edit the script.

---

## Running saved scripts

You can run a saved script by selecting the script from the **Select Script** drop-list, or by navigating to the folder where the script is located. You can also add folders containing scripts to the **Select Script** drop-list.

You can also run multiple scripts in a sequence. If you have a single script with too many operations, you may want to spread the tasks into several scripts that you can run in a specific order. This modularity makes it easier for you to maintain scripts and allows you to work around memory limitations.

When you have scripted actions that involve dialog boxes, you can choose to run the script in Silent mode, so the dialog boxes do not

appear as the script runs. Conversely, you can choose to run the script in Interactive mode, so that dialog boxes appear for user interaction. For more information, see “To set a playback mode for a script action or command” on page 717.

## To run a script listed in the Select Script drop-list

Edit workspace

- 1 On the Script toolbar, click the **Select Script** drop-list to display the scripts.
- 2 Click the script that you want to run.
- 3 Click the **Run Selected Script** button .



You can add any folder to the list of folders that the **Select Script** drop-list displays by clicking the drop-list and clicking the **File Locations** button . In the File Locations dialog box, click **Add** and navigate to the folder that contains the scripts.

## To run a script not listed in the Select Script drop-list

Edit workspace

- 1 On the Script toolbar, click the **Run Script** button  to open the Run Script dialog box.
- 2 Choose the folder that contains the script you want to run.
- 3 Select the script.
- 4 Click **Open**.

## To run multiple scripts

Edit workspace

- 1 Click an open image to make it active.
- 2 On the Script toolbar, click the **Run Multiple Scripts** button  to open the Run Multiple Scripts dialog box.
- 3 From the left pane, double-click the scripts that you want to run

- 4 Click **Run**.

## To run scripts on all open images

Edit workspace

- 1 Run a script or multiple scripts on an image.
- 2 Open the History palette by pressing **F3**.
- 3 Right-click the scripts in the History palette and choose **Apply to other open documents**.



You can also run scripts on another open image by dragging the actions from the History palette and dropping them onto the image.

To run the last executed script or multiple scripts on another open image, click the image to make it active, and then press **Ctrl + Y**.

## To toggle between Interactive and Silent script playback mode

Edit workspace

- Click the **Toggle Execution Mode** button  on the Script toolbar. When the button has a border around it, it is in Interactive mode.



If you've edited the script and set part or all of it to run in either Silent or Interactive mode, clicking the **Toggle Execution Mode** button  will not override that setting. If a script is set to Default mode, the state of this button will override the Toggle Execution Mode setting. The Toggle Execution Mode setting affects only those steps and commands set to Default mode within the script.

## Stopping or undoing a script

You can stop a script while it is running. You can also undo a script after you've run it.

### To stop a running script

Edit workspace

- Click the **Stop Script** button .



The Stop Script button is only active while the script is running. Depending on the script, this may only be a few seconds.

### To undo an applied script

Edit workspace

- Click the **Undo** button  on the Standard toolbar.

## Editing scripts in Corel PaintShop Pro

You can edit scripts using the Corel PaintShop Pro user interface, or by editing the script's Python code in a text editor application. For more information about editing scripts, see "Editing scripts using a text-editing application" on page 718.

### To edit the currently selected script

Edit workspace

- 1 Click the **Edit Selected Script** button  to display the Script Editor dialog box.

The commands and actions that comprise the script appear in the Script Commands group box.

- 2 Make changes to the script.

Specific editing actions can be found in the table below.



**Note:** Command names shown in italics with the words “NOT editable” cannot be selected for editing.

- 3 Click **Save**.
- 4 Click **Close**.

### You can also

---

Disable a script action or command	Unmark the check box beside the action or command.
Remove a script action or command	Click the action or command, and click <b>Delete</b> .
View or edit the Python code associated with the script	Click <b>Text Editor</b> . The text editor assigned in the File Locations dialog box opens the script. Unless you specify another application, the default editor is Notepad.

---



If the script format is unreadable, or if the script was created and edited manually in a text editor, the Corel PaintShop Pro Script Editor cannot open the script. Instead, the script opens in the default text editor that is specified in the File Locations dialog box. For more information, see “Editing scripts using a text-editing application” on page 718.



If the script you want to edit is not in the **Select Script** drop-list, choose **File ▶ Script ▶ Edit** and choose the folder where the script is saved. When you open the script, its information appears in the Script Editor dialog box.

## To set a playback mode for a script action or command

Edit workspace

- 1 Click the **Edit Selected Script** button  to display the Script Editor dialog box.

- In the Scripts Commands group box, choose one of the following options from the **Mode** drop-list:
  - **Default** — uses whatever mode was specified in the Run Script command.
  - **Silent** — skips all dialog boxes associated with that command or action when you run the script. Use this mode when you feel it's best to avoid interacting with a dialog in the script.
  - **Interactive** — allows for user interaction with dialog boxes and other settings

## Editing scripts using a text-editing application

You can edit the Python code in the text editor of your choice. The editor application designated for script editing will open.

### To edit Python code

Edit workspace

- Click the **Edit Selected Script** button  to display the Script Editor dialog box.
- Click **Text Editor**.

The text editor assigned in the File Locations dialog box opens the script.



Until you specify another application, the default editor is Notepad.

### To change text-editing applications

Edit workspace

- Choose **File ▶ Preferences ▶ File Locations** to display the File Locations dialog box.
- In the File Types list, choose **Python Source Editor**.

- 3 Click **Browse**, and choose a text-editing application.  
The Python Source Editor Path dialog box appears.
- 4 Click **Open**.
- 5 Click **OK**.



You can also click the **File Locations** button  in the **Select Script** drop-list to open the File Locations dialog box.

## Troubleshooting a script

To selectively apply actions to the current image and identify any scripting problems, you can run a script step-by-step.

### To step through a script

Edit workspace

- 1 Choose **File ▶ Script ▶ Single Step**.  
Corel PaintShop Pro is in Script Single Step mode.
- 2 Run the desired script.  
The Step Script dialog box appears, listing the script's name and first action.
- 3 Click any of the following as you step through the script's commands and actions:
  - **Continue** — applies the command to the image and moves on to the next command in the script
  - **Skip Command** — does not apply the command to the image and moves on to the next command in the script
  - **Stop Scripts** — cancels this operation and closes the Step Script dialog box

**Note:** Corel PaintShop Pro remains in Script Single Step mode until you toggle off this command by choosing **File ▶ Script ▶ Single Step** again.



When using this feature, it's helpful to display the Script toolbar by choosing **View ▶ Toolbars ▶ Script**.

## Assigning icons to scripts

You can assign any of 50 icons to a script, and then drag the icon to a custom or existing toolbar, or to a menu. By dragging the icon onto a toolbar or menu you can have easier, quicker access to your favorite scripts, and can execute them with a single click.

You can use an icon for any number of scripts. For example, you could assign a red light bulb icon  to a script and drag it to the Photo toolbar. You could then assign the same icon to a different script and drag it to the Adjust menu.

The process of assigning an icon to a script is called “binding”. After the script is bound, you can assign a keyboard shortcut to it as another way to execute the script. For more information about using shortcuts, see “Customizing keyboard shortcuts” on page 666.

### To assign an icon to a script

Edit workspace

- 1 Choose **View ▶ Customize** to display the Customize dialog box.
- 2 Click the **Scripts** tab.
- 3 Choose the script from the drop-list.
- 4 Choose an icon, and then click **Bind**.

The icon and its associated script appear in the list in the Bound Scripts group box.

- 5 From the Bound Script group box, drag the icon or script into a menu or toolbar.



When you position the cursor over the toolbar's script icon, you'll see the path name and file name associated with the script. If you drag the script icon into a menu, the menu displays the script's name, and the script's path appears in the status bar.

## To unbind a script from an icon

Edit workspace

- 1 Choose **View ▶ Customize** to display the Customize dialog box.
- 2 Click the **Scripts** tab.
- 3 In the Bound Script group box, choose the icon or script name.
- 4 Click **Remove**.



When you unbind a script from an icon, you also remove it from the user interface and from any keyboard shortcut assigned to it.

## To remove a bound script icon from a menu or toolbar

Edit workspace

- 1 Choose **View ▶ Customize** to display the Customize dialog box.
- 2 Drag the script's icon into the Corel PaintShop Pro workspace.

## Using and creating presets

Presets are scripts that define the behavior, properties, or settings of a dialog box or tool. Many dialog boxes and tools come with predefined, ready-to-use presets; however, you can also design and save your own presets. This is useful if you frequently use the same settings in a dialog box or with a tool. By using presets, you can save the settings and they'll appear in the **Presets** drop-list associated with that dialog box or tool.

## To choose a preset

Edit workspace

- In the **Presets** drop-list, select the desired preset from the list.

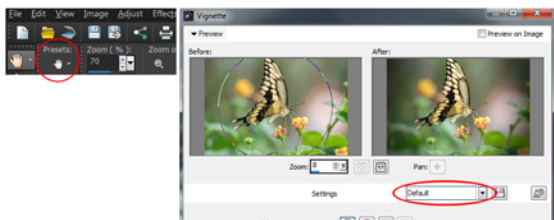

*On the left is the Pan tool's Presets drop-list button in the Tool Options palette, and on the right the Presets drop-list button in the Charcoal effect dialog box.*

## To reset values to default settings

Edit workspace

- In the **Presets** drop-list, click the **Reset to default** button .



To reset a dialog box to the settings that displayed when you opened the dialog box, hold down **Shift** and click the **Reset to default** button.

## To save settings as a preset

Edit workspace

- Modify the settings in the dialog box or the Tool Options palette.
- Click the **Save preset** button  to display the Save Preset dialog box.
- Type a name for the preset.

**Note:** You cannot use "Default" or "Last Used" as the name for a preset.

If you want to enter additional preset information, click **Options**, and type text in the **Author**, **Copyright**, and **Description** fields.

- 4 Click **OK**.



The **Preset includes** group box shows the data saved with a preset.

## To edit a preset

Edit workspace

- 1 Modify the settings in the dialog box or the Tool Options palette.
- 2 Click the **Save Preset** button .
- 3 Type the same preset name in the preset name box.
- 4 Click **Options**.

If you want to omit any data from the **Preset includes** group box, click the **Include/Exclude** button  associated with the data.

A white “X” appears over the button associated with the item.

- 5 Click **OK**.

## To delete a preset

Edit workspace

- 1 In the **Presets** drop-list, click the **Resource Manager** button .
- 2 In the Resource Manager dialog box, select the preset you want to delete.
- 3 Click **Delete**.

## Processing files in batches

You can process multiple files using the Batch Process feature.

Corel PaintShop Pro can make copies of original files, convert them and then save the copies in the output folder you select.

## To convert multiple files to a new format

### Edit workspace

- 1 Choose **File ▶ Batch Process** to open the Batch Process dialog box.
- 2 Click **Browse**, and choose the file you want to process from the Select Files dialog box.

If you want to choose adjacent files, hold down **Shift** as you click; to choose non-adjacent files, hold down **Ctrl** as you click.

- 3 Click **Select**.

The files you choose appear in the **Files to process** list in the Batch Process dialog box.

- 4 In the Save Mode group box, choose an option:

- **New Type** — This is the most basic option, requiring only that a new output type be set in the **Type** field of the Save Options group box. You can also choose to run a script with this option. This option reads in the file, runs the script (if defined) against the file, saves the file to its new location and/or name, and converts it to the new file format.
- **Copy** — This option requires that a script be defined in the Script group box. This option reads in the file, runs the script against the file, and saves the file to a new location and/or name. With this option selected, the **Type** field and **Options** button of the Save Options group box are disabled.
- **Overwrite** — This option requires that a script be defined in the Script group box. This option reads in the file, runs the script against the file, and saves the file to its original location (the original file is overwritten). With this option selected, all Save Options group box settings are disabled.

- 5 Click **Options** to open the **Save Options** dialog box.

**Note:** Not all file formats have associated options. If the file format you choose does not have any options, the **Options** button is unavailable.



- 6 Choose options from the **Format** and **Encoding** group boxes.
- 7 Click **Start** to open the Batch Progress dialog box and start the batch conversion.

The Current Step pane displays each filename and its conversion status. The Job Progress bar indicates the conversion progress.

- 8 Click **OK**.

Unless you specify another output folder, Corel PaintShop Pro saves the converted files in the same folder as the source files.

## You can also

Rename converted files	Click <b>Modify</b> , choose an option from the <b>Rename Options</b> list, and click <b>Add</b> . You can rename the file with the current date, document name, position of the file in the renaming process, the current time, and custom text.
Stop the conversion	Click <b>Cancel</b> .
Run a script during the file format conversion	In the Script group box, mark the <b>Use Script</b> check box and choose a script from the drop-list.
Save a log file	In the Batch Progress dialog box, click <b>Save Log</b> , and choose the folder in which you want to save the log.

## To run a script on multiple files

Edit workspace

- 1 Choose **File ▶ Batch Process** to open the Batch Process dialog box.
- 2 Click **Browse** to open the Select Files dialog box.
- 3 Choose the folder where the files are stored.
- 4 Do one of the following:
  - To select adjacent files, hold down **Shift** and click the files.

- To select non-adjacent files, hold down **Ctrl** and click the files.

5 Click **Select**.

The files appear in the **Files to process** list in the Batch Process dialog box.

6 In the **Save Mode** group box, choose one of the following options:

- **New Type** — runs the script and saves the processed files as a new file type. You can choose to save the output files to another folder by clicking **Browse**.
- **Overwrite** — runs the script and saves the file to its original location, overwriting the original file
- **Save Script** — runs the script but does not save the file. Use this option when the script performs a save on the file.

If you choose **Copy**, you can rename the converted files by clicking **Modify**, choosing an option from the **Rename Options** list, and clicking **Add**. You can rename the file with the current date or time, a document name, the position of the file in the renaming process, or by custom text.

If you choose **Overwrite**, you can clear the **Stop on error** check box to avoid having to confirm the overwriting of each file.

7 In the Script group box, mark the **Use Script** check box.

8 Choose a script from the drop-list.

9 Click **Start**.

The Batch Progress dialog box opens and the batch conversion starts. The Current Step pane displays each filename and its conversion status. The Job Progress bar indicates the conversion progress.

10 Click **OK**.

### You can also

---

Stop the script

Click **Cancel**.

---

## You can also

---

Stop the script if Corel PaintShop Pro encounters an error	Mark the <b>Stop on error</b> check box. If you don't mark it, the program processes all the images without stopping. The error messages appear in the Batch Conversion Status dialog box.
Run the script in Silent Mode	Mark the <b>Run script in silent mode</b> check box.
Save a log file	In the Batch Progress dialog box, click <b>Save Log</b> , and choose the folder in which you want to save the log.

---

## Renaming files in batches

You can rename multiple files at the same time.

### To rename files in a batch

*Edit workspace*



- 1 Choose **File ► Batch Rename** to open the Batch Rename dialog box.
- 2 Click **Browse**.
- 3 Choose the folder that contains the source files.
- 4 Do one of the following:
  - To select adjacent files, hold down **Shift**, and click the files.
  - To select non-adjacent files, hold down **Ctrl**, and click the files.
- 5 Click **Select**.

The files appear in the **Files to rename** list in the Batch Rename dialog box.
- 6 Click **Modify** to open the Modify Filename Format dialog box.

- 7 Choose any of the following renaming options from the **Rename Options** list:
  - **Custom Text** — to add text to the converted files
  - **Date** — to add the current date to the file name
  - **Document Name** — to add the original file name to the new file name, and to change the case
  - **Sequence** — to add the numerical position of a file in the renaming process
  - **Time** — to add the current time to the file name
- 8 Click **Add** for each option you want to move into the **Included** list. The file naming scheme appears at the bottom of the dialog box.
- 9 Click **OK**.

If you want to stop the renaming process when Corel PaintShop Pro encounters an error, mark the **Stop on error** check box in the Batch Rename dialog box.
- 10 Click **Start**.



You can use click the **Move Up**  and **Move Down**  buttons in the Modify Filename Format dialog box to rearrange the order of options you choose from the **Rename Options** list.



Corel PaintShop Pro provides extensive options for printing your work. This section presents the following topics:

- Printing images
- Creating layouts
- Editing templates
- Editing and saving layouts
- Printing CMYK color separations
- Understanding printing

## Printing images

Corel PaintShop Pro offers many ways to print images. You can print from the Manage workspace, Edit workspace, or Adjust workspace. You can use a template, or use a custom layout to meet specific size and layout requirements.



*You can print contact sheets (left), print to standard photo sizes (center), or create custom print layouts (right).*

Templates help you simplify image placement and sizing. You can use templates to lay out and print images in standard sizes, including 4 × 6 inches, 5 × 7 inches, and 10 × 15 centimeters. You can use a Corel PaintShop Pro template, or you can create your own custom template from a page layout that you create.

Creating your own layouts gives you the flexibility to print images to any size and lets you create a custom page for projects such as scrapbooks. For more information about creating layouts, see “Creating layouts” on page 735.

If you are preparing images for professional output, you can print an image to a file, which lets a service bureau send the file directly to an output device. If you are unsure about which settings to choose, consult the service bureau. You can also print crop and registration marks. Crop marks represent the size of the paper and print at the corners of the page. You can print crop marks to use as guides to trim the paper. Registration marks are required to line up film for proofing or printing plates on a color press. They print on each sheet of a color separation.

## To print the active image

Edit workspace

- 1 Choose **File** ► **Print**.
- 2 In the **Printer** group box, click **Printer**.  
The Print dialog box appears.
- 3 Choose a printer from the **Name** drop-list, and click **OK**.
- 4 Click the **Placement** tab, and type or set a value in the **Number of copies** control.
- 5 In the **Orientation** group box, choose one of the following options:
  - **Portrait**
  - **Landscape**
- 6 In the **Size and Position** group box, set any of the following controls:
  - **Width and Height** — lets you specify width and height values to set the image size
  - **Scale** — lets you resize the image by entering a percentage
  - **Fit to page** — fits the image to the printed page
  - **Center on page** — centers the image on the printed page
  - **Upper left of page** — positions the image in the upper-left corner of the printed page
  - **Custom offset** — lets you enter values in the **Left offset** and **Top offset** boxes
- 7 Click the **Options** tab.
- 8 In the **Print Output** group box, choose one of the following options:
  - **Color**
  - **Greyscale**
  - **CMYK separations**

If you choose the **CMYK separations** option, you can print CMYK labels on each color plate or page by marking the **CMYK plate labels** check box in the **Print Marks** group box.

- 9 Click **Print**.

## You can also

---

Print the filename below the image	Mark the <b>Image Name</b> check box in the <b>Print Marks</b> group box.
------------------------------------	---

---

Print a negative of the image	Mark the <b>Negative</b> check box in the <b>Color Options</b> group box.
-------------------------------	---

---

Print a color background around the image	Mark the <b>Background</b> check box, click the color box, and choose a color from the color palette.
---	---

---



You can script most print options; however, because of variations in printer drivers, not all printer settings are scriptable. For more information about scripting, see “Scripting basics” on page 705.

For more information about printing options, see “Creating layouts” on page 735.

## To print a contact sheet

### Manage workspace

- 1 In the Organizer palette, select the files that you want to print.
- 2 On the Organizer toolbar, click the Organizer menu button  and choose **Print Contact Sheet**.
- 3 Specify the settings you want in the Print Contact Sheet dialog box.
- 4 Click **Print**.





For more information about printing options, see “Understanding printing” on page 746.

## To print to a file

Edit workspace

- 1 Choose **File ▶ Print**.
- 2 Mark the **Print to File** check box.
- 3 Click **Print**.
- 4 Type a name in the **Output File Name** box.

## To print images by using a template

- 1 In the Manage or Edit workspace, select thumbnails in the Organizer palette.
- 2 Choose **File ▶ Print Layout**.  
The Print Layout window appears.
- 3 Click **File ▶ Open Template**.  
The Templates dialog box appears.
- 4 In the **Category** group box, choose a category from the list.  
Thumbnails of the templates in each category appear in the window on the right. Custom templates that you saved appear under the **User Defined** category. If the custom template was saved with images, the cells are filled with color.
- 5 Select a template, and click **OK**.  
**Note:** If you previously saved images with the template, the images appear in the template cells and in the thumbnail list. Cells are grayed in the template thumbnail for templates with missing images.
- 6 Drag images into the template cells.

If you want to fill the template with copies of the same image, click a thumbnail and click the **Fill Template with Image** button



- 7 Click **File ▶ Print**.



For information about saving templates with links to images, see “Setting file locations” on page 691.



You can remove an image from a template by selecting the image and pressing **Delete**.

You can also open images by choosing **File ▶ Open Image**.

## To print crop and registration marks

*Edit workspace*

- 1 Choose **File ▶ Print**.
- 2 In the **Printer** group box, click **Printer**.  
The Print dialog box appears.
- 3 Choose a printer from the **Name** list box, and click **OK**.
- 4 Click the **Options** tab.
- 5 In the **Print Marks** group box, mark one or more of the following check boxes:
  - **Corner Crop Marks** — prints crop marks at the corners of the image
  - **Center Crop Marks** — prints crop marks at the center of the image edges
  - **Registration Marks** — prints registration marks at the corners of the image

## Creating layouts

You can create a print layout and position images individually, or you can apply the same settings to all of the images.

By rotating and zooming, you can change the print layout of your images. Images are displayed at 100% magnification by default. You can zoom in to get a closer look at image detail, or zoom out to view a larger portion of the image.

When you use a print layout, you can add descriptive text captions, undo or redo the changes you make, and save the layout for future use as a template.

### To add images to a layout

*Edit workspace*

- 1 Open the image that you want to print.  
If you want to select more than one file, hold down **Ctrl**, and click the files. If the files are in sequential order, click the first file, and then press **Shift** and click the last file.
- 2 Choose **File ▶ Print Layout** to open the Print Layout window.  
Thumbnails of the selected images appear on the left side of the window; the page layout appears in the main workspace.  
If you want to add additional images to the Print Layout window, choose **File ▶ Open Image**, and choose the images.
- 3 Drag the thumbnails into a template cell or onto the custom layout page.

### You can also

---

Print the page with the current settings

Click the **Print** button .

---

## You can also







---

Change the print setup options	Choose <b>File ▶ Print Setup</b> . In the Print Setup dialog box, make changes to any of the settings.
Close the Print Layout window	Click the <b>Close Print Layout</b> button  .

---

## To position images in a layout

### Edit workspace



- 1 In the Print Layout window, choose a cell.
- 2 Click one of the following buttons:
  - **Fill Template with Image**  — fills the template with the image
  - **Free Format**  — lets you manually resize and position the image in the cell
  - **Size and Center**  — retains the image size and centers it in the cell
  - **Fill Cell with Image**  — centers the image and scales it to fill the cell. The aspect ratio is maintained, but parts of the image may not be visible.
  - **Fit and Center**  — centers the image and scales the image to fit entirely inside the cell. The image aspect ratio is maintained.
  - **Make Cell Elliptical**  — creates an elliptical cell shape
  - **Make Cell Rectangular**  — creates a rectangular cell shape



You can display the grid if you want to position images with precision.





## To rotate an image in a layout

Edit workspace

- 1 In the Print Layout window, select an image.  
If you want to rotate multiple images, hold down **Shift**, and select the images.
- 2 On the toolbar, click one of the following buttons:
  - Rotate Right 
  - Rotate Left 

## To zoom

Edit workspace

To	Do the following
Zoom in	Click the <b>Zoom In 10%</b> button  .
Zoom out	Click the <b>Zoom Out 10%</b> button  .
Zoom in on a specific area	Click the <b>Zoom Rectangle</b> button  Drag in the page layout to choose an area to zoom in on.
Zoom to the fill the workspace with the layout	Click the <b>Zoom to Page</b> button  .

## To create a caption

Edit workspace

- 1 Choose **File ▶ Print Layout** to open the Print Layout window.  
Thumbnails of the open images appear on the left side of the window; the page layout appears in the print layout workspace.
- 2 Drag the thumbnails into a template cell or onto the custom layout page.
- 3 Click the **Create a Text Field** button .
- 4 Drag to create the text box.

- In the Text Field dialog box, type the text that you want to appear on the printed page.
- Set the font, font attribute, and alignment controls.  
**Note:** To continue to use these settings, mark the **Retain text settings** check box.
- Click **OK**.

### You can also

---

Move the text box in the image	Drag the text box.
Size the text box	Drag the corner handles in or out.
Rotate the text	Right-click the text box, and choose <b>Rotate Right</b> or <b>Rotate Left</b> .

---

### To undo or redo a change to a layout

#### Edit workspace

- Choose **Edit ▶ Undo** to undo a change to a layout, or **Edit ▶ Redo** to redo a change to a layout.

### To change the Print Layout workspace

#### Edit workspace

- In the Print Layout window, choose **View ▶ Options**.  
The Print Layout Options dialog box appears.
- Choose a unit of measurement from the **Units** drop-list.
- In the **Auto Arrange** group box, mark one or both of the following check boxes:
  - Use borders** — creates a border around all images. This option requires you to set values in the **Horizontal border size** and **Vertical border size** controls.
  - Stretch to fit** — automatically enlarges images to fit, while maintaining their aspect ratios

- 4 In the **Template options** group box, do one or both of the following:
  - To apply the new default placement option to all cells of the current template, mark the **Apply to current template** check box.
  - To specify the default placement of images in template cells, choose an option from the **Default Placement** drop-list.
- 5 In the Grid Settings group box, mark any of the following check boxes:
  - **Show Grid** — displays the grid
  - **Snap-to-Grid** — snaps images to the gridlines where you position them

If you marked the **Show Grid** check box, you can also mark the **Dot Grid** check box to use a dotted-line grid. Clear the check box to use a solid-line grid.

- 6 Click **OK**.

### You can also

---

Change the grid color	Click the <b>Grid color</b> area, and choose a color from the color palette.
Change the horizontal and vertical spacing	Set values in the <b>Horizontal Spacing</b> and <b>Vertical Spacing</b> controls.

---

## Editing templates

In Print Layout mode, you can make changes to multiple cells at the same time. However, the position and size of a cell are locked when the layout is saved as a template, so template cells cannot be moved or resized. You can add descriptive text to a template, which can be helpful for future browsing.

If a print layout contains images that you want to print repeatedly, you can save the layout as a template with links to the images. Whenever you open the template, it displays the images in the layout.

If you no longer need a print template that was saved, you can easily delete it.

***Important!** When you print a template on thick paper, such as glossy photo paper, the images in the printed template may not fit perfectly inside the cell borders. You can correct this by adjusting the position of the template layout in Corel PaintShop Pro.*

## To edit template cells

Edit workspace

- 1 Click the cell you want to edit.

If you want to edit multiple cells, hold down **Ctrl** while clicking the cells.

- 2 Choose **Edit**, and then choose the commands you want to apply to the template cells.

## To enter descriptive text for a template

Edit workspace

- 1 Load a template, or create a new template.
- 2 On the **Print Layout** toolbar, click the **Save Template** button .

The Save dialog box appears.

If you want to create a specific name for the template, enter it in the **Name** field.

- 3 In the **Description** field, enter the information you want.

If you want to save the template with the images it contains, mark the **Save with images** check box.

- 4 Click **OK**.



If you did not change the template name, you are prompted to overwrite the template or cancel the action.

## To move the template position

Edit workspace

To	Do the following
Move the template 1/20th of an inch (1.25 mm)	Hold down <b>Ctrl</b> , and press the arrow keys.
Move the template 1/10th of an inch (2.5 mm)	Hold down <b>Ctrl</b> and <b>Shift</b> , and press the arrow keys.



If your printer consistently misprints the same way, adjust the template position, and save it with a name that specifies its use with that printer.

## To revert a template with images to a layout

Edit workspace

- 1 Open the template you want to edit.
- 2 Click the **New Template** button .  
A dialog box appears, asking whether to keep the current images in the new template.
- 3 Click **Yes**.

## To save a template with images

Edit workspace

- 1 Click the **Save Template** button .  
The Save dialog box appears.
- 2 Enter a name for the new template in the **Name** field.
- 3 Mark the **Save with Images** check box.
- 4 Click **OK**.

## To delete a template

Edit workspace

- 1 Choose **File ▶ Print Layout**.
- 2 In the Print Layout window, click **Open Template** .  
The Templates dialog box appears.
- 3 Choose a category from the **Select A Category** list.
- 4 Select the thumbnail of the template you want to delete.
- 5 Click **Delete**.

## Editing and saving layouts

Corel PaintShop Pro includes many templates with different layouts that you can use to print your images. The layouts you create can be saved as templates.

You can arrange images in a layout automatically or manually. Before you arrange images automatically, you must choose whether to include borders. If you do not use borders, Corel PaintShop Pro may arrange the images with touching edges. You must also choose whether to size the images to fit the layout. If you do not choose this option, Corel PaintShop Pro keeps them the same size or, if necessary, makes them smaller to fit the layout. Corel PaintShop Pro divides the page into sections of equal size and places each image in a section. Only images on the page or in the workspace are used.

Horizontal and vertical gridlines help you position items evenly on a page. You can display or hide grids and set preferences for grid spacing and appearance. When you display grids, they appear in any image window that is open.

You can snap images to the nearest gridline on the layout.

## To resize an image in print layout

Edit workspace

- 1 Click the **Resize** button  on the toolbar.
- 2 Choose one of the following options:
  - **Percent of original** — resizes an image by a percentage you specify in the **Width** or **Height** boxes
  - **Actual / Print size** — resizes an image by the dimensions you specify in the **Width** or **Height** boxes without changing its aspect ratio



Resizing an image for printing can result in poor image quality. When you enlarge an image, it loses detail and sharpness. As a general rule, it is best to avoid enlarging or reducing an image by more than 25 percent.



You can also resize an image manually by dragging a corner handle.

## To use borders in a print layout

Edit workspace

- 1 Choose **View ▶ Options**.
- 2 Mark the **Use Borders** check box, and type or set values in the **Horizontal border size** and **Vertical border size** controls.  
The default border width is 0.5 inches (1.27 centimeters).
- 3 Click **OK**.



If you want to resize images to fit in their cells, mark the **Stretch to fit** check box.

As you decide where to move images, you can place them temporarily in the workspace around the page.

You can also arrange images manually by dragging the image to a new position on the page.

## To display the grid

Edit workspace

- Choose **View** ▶ **Show Grid**.

## To snap images to the layout grid

Edit workspace

- Choose **View** ▶ **Snap to Grid**.

## To change layout grid settings

Edit workspace

- 1 Choose **View** ▶ **Options**.

The Print Layout Options dialog box appears.

- 2 In the **Grid Settings** group box, mark any of the following check boxes:

- **Show Grid** — displays the grid
- **Snap-to-Grid** — snaps images to the gridlines when you position them

**Note:** If you mark the **Show Grid** check box, you can mark the **Dot Grid** check box to use a dotted-line grid instead of a solid-line grid.

## You can also

---

Change the grid color

Click the **Grid color** area, and choose a color from the color palette.

---

Change the horizontal and vertical spacing

Set values in the **Horizontal Spacing** and **Vertical Spacing** boxes.

---

## To save a custom layout as a template

Edit workspace

- 1 Click the **Save Template** button .  
The Save dialog box appears.
- 2 Enter a name for the new template in the **Name** field.  
If you want to save the image links with the template, mark the **Save with Images** check box.
- 3 Click **OK**.

## To rotate an image in a layout

Edit workspace

- 1 Select the image.
- 2 Choose **Image**, and then choose one of the following commands:
  - **Rotate Right**
  - **Rotate Left**

## To position an image in a layout

Edit workspace

- Drag the image to a new position on the page.

## Printing CMYK color separations

Corel PaintShop Pro converts images for color printing by replacing the RGB (Red, Green, and Blue) colors you see on the monitor with the CMYK (Cyan, Magenta, Yellow, and Black) colors used in printing. You can then print a separate page for each CMYK color, which is useful if your work will be handled by a prepress service provider or a high-quality printer.

Printing CMYK color separations differs from splitting color channels. When you split color channels, Corel PaintShop Pro treats white as having full color and black as having no color. When you print CMYK

separations, Corel PaintShop Pro treats black as having full color and white as having no color.

## To print CMYK color separations

Edit workspace

- 1 Choose **File ▶ Print**.

The Print dialog box appears.

- 2 Click the **Options** tab.
- 3 In the **Print Output** group box, choose **CMYK Separations**.
- 4 Click **Print**.



You can also choose other print options. For more information, see “Printing images” on page 729.

## Understanding printing

Whether you are new to printing or would like a quick review, this reference section can help you understand some of the factors that affect the printing of your images.

### Image and printer resolution

Laser and ink-jet printers work by applying dots of black or colored ink to paper. Whereas image resolution is measured in pixels per inch (ppi), printer resolution is measured in dots per inch (dpi). The printed image size is expressed in inches and is calculated as the image size in pixels divided by pixels per inch. For information about viewing image information, see “Viewing images and image information” on page 76.

Images with higher dpi values have more data and result in higher print quality. You can resize images, to create a larger print size, but the print quality can decrease due to the reduced print resolution (ppi). For

information about resizing images, see “Resizing images” on page 221.

It is best to consider the resolution of the printer when you choose a resolution for the image you are creating. You can use the following guidelines to determine the image size for printing:

- For a 300-dpi printer, use an image that is 72 to 120 ppi.
- For a 600-dpi printer, use an image that is 125 to 170 ppi.
- For a 1200-dpi printer, use an image that is 150 to 200 ppi.

### **Image color and lightness**

Computer monitors display color by combining red, green, and blue light on the screen. Color printers, however, use a combination of cyan, magenta, yellow, and black inks. The differences between these two color modes can cause images to appear darker on paper than on the screen. As you become familiar with how your printer handles color, you can adjust your images to compensate for these differences. If the printed image appears too dark, you can adjust the brightness or contrast.

### **Paper quality**

The texture and color of the paper used for printing affect the quality of the printed image. For example, porous paper can cause colors to bleed into each other, colored paper can alter the image colors, and off-white paper can reduce the contrast and vibrancy of the image colors. For recommendations on which paper to use for printing, refer to the documentation supplied with your printer.

### **File formats**

Saving your image in the PspImage format provides the most flexibility if you plan to print your image on a personal printer.

Corel PaintShop Pro prints all layers in an image, so you do not need to

flatten the image by merging the layers. If you are using a black-and-white printer, you can print your images in grayscale.

If you are sending the image to a printing service, you need to flatten the image — that is, merge the layers — before you save the image. The program automatically flattens an image when you save it in most formats other than PspImage. It is best to consult with your printing service about file format, resolution, and color depth requirements.





Corel PaintShop Pro gives you options for e-mailing your photos or sharing them on a sharing site.

This section presents the following topics:

- E-mailing photos
- Uploading photos to a sharing site
- Creating Share My Trip projects

## E-mailing photos

You can e-mail photos directly from any Corel PaintShop Pro workspace.

You can e-mail items in the following ways.

- **Embedded photos** — You can embed photos so they are displayed in the body of your e-mail message. This means that the person who receives your e-mail can see the photos as soon as the e-mail is open. Embedded photos only appear in e-mail that uses the HTML message format. This is a standard message format, but if you know your recipient uses plain text or Rich Text Format (RTF), use the Attachments option.
- **Attachments** — You can send photos as file attachments. Each item is attached as an individual file, the original file format is preserved, and the e-mail recipient can choose how to view the photos.

## Choosing a size for your photos

You can resize your photos to reduce their dimensions or to reduce the overall size of the e-mail. For example, you may want to reduce the size of a photo so you can send it to a mobile device. The Maximum Photo Size setting lets you choose the maximum width of the photos in pixels without affecting the proportions of the image. For example, if your photo is 2048 pixels × 1536 pixels, and you choose a maximum photo size of 640 pixels, then your image is resized to 640 pixels × 480 pixels. The dimension information for each image is displayed above the preview thumbnail in the E-mail dialog box and the total e-mail size estimate is displayed beside the preview thumbnail.

## E-mail application

To send items using e-mail, you must connect to the Internet and your computer must have a default e-mail application that supports the MAPI Standard (such as Microsoft Outlook) and be configured to use the MAPI e-mail client.

## To e-mail photos

- 1 Choose **File ▶ E-mail**, and choose one of the following options:
  - **Active image** — lets you send the photo that is currently active in the image window
  - **All open images** — lets you send all the photos that are open in the image window
  - **All selected items** — lets you send all the photos that you currently have selected
- 2 In the E-mail dialog box, choose one of the following options:
  - **Embedded photos** — displays photos in the body of your e-mail message

- **Attachments (original file format)** — sends photos as individual file attachments. This option preserves the original file formats.
- 3 Choose a size setting from the **Maximum photo size** drop-list.  
The total size of your e-mail is displayed beside the preview.



Some e-mail providers limit the size of e-mails, which could prevent large e-mails from being sent or received. You can reduce the size of the e-mail by choosing a smaller **Maximum photo size** setting or by selecting fewer photos.

The Embedded photos option is available only for e-mail clients that support extended MAPI, such as Outlook.



You can review the items you are sending by clicking the playback arrows that appear under the Preview thumbnail.

## Uploading photos to a sharing site

You can upload your photos to sharing sites, such as Facebook, Flickr, and Google+, directly from the application when you are connected to the Internet.

While uploading photos, you can organize them into albums. You can choose from a list of existing albums, or you can create new albums.

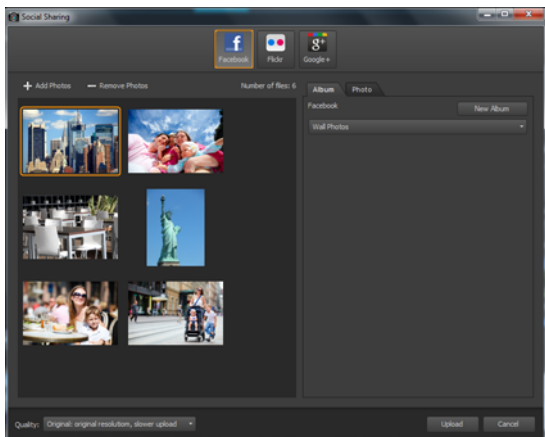

*You can upload files to sharing sites, such as Facebook, Flickr, and Google+.*

## Choosing output quality

When choosing the output quality of your photos, you have two options:

- **Original** — preserves the image as it is and allows for maximum quality.
- **Recommended** — decreases the file size and the quality of the image to optimize it for upload. Smaller files can be uploaded faster.

## To upload photos to a sharing site

- 1 In the Organizer palette (available from any workspace), select the photos that you want to share.

If the Organizer palette is not displayed, click **View** ▶ **Palettes** ▶ **Organizer**, or press **Shift + F9**.

- 2 Click the **Share** button .
- 3 In the Share Photos dialog box, click any of the following sharing site buttons:
  - **Facebook**
  - **Flickr**
  - **Google+**
- 4 Click the **Album** tab, and do one of the following:
  - Choose an album from the list to add your photos to an existing album.
  - Click **New Album**, type a name and description, and click **Create** to create a new album for your photos.
- 5 Click the **Photo** tab, and edit any of the fields.

If you have more than one sharing site selected, the fields might not apply to all of the sharing sites—only the information supported by a given sharing site is uploaded.
- 6 Choose an option from the **Quality** drop-list.
- 7 Click **Upload**.



If you want to upload photos to a site that you are not currently connected to, you will be asked to log in before you can upload your photos.

If you want location information about your photos to appear on the sharing site, make sure that your privacy settings allow location information to be visible.

If you are unable to log in from a corporate network, you may need to modify the Proxy Server settings on your computer. Check with your Network Administrator to get the Proxy Server information for your corporate network.



You can add or remove photos by clicking **Add photos** or **Remove photos**.

## Creating Share My Trip projects

You can create an interactive slideshow of your photos and show them on a map. The project that you create is saved as HTML output that can be posted on your blog or uploaded to Dropbox. If you upload the project to Dropbox, you can automatically post the link on Facebook.

For more information about mapping your photos, see “Adding location information” on page 118.

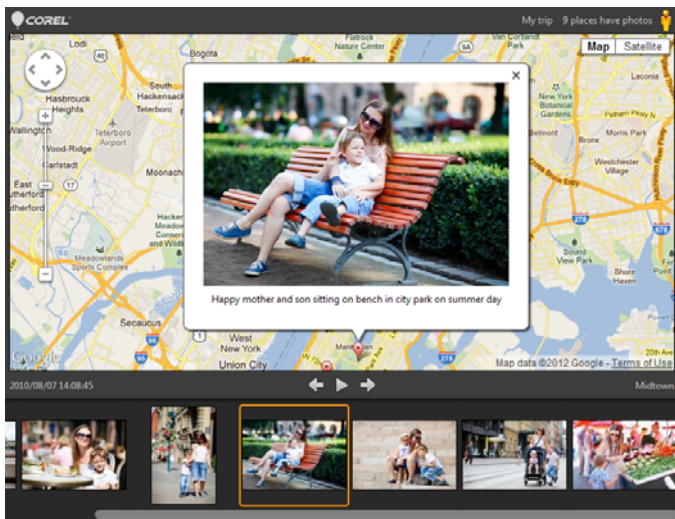

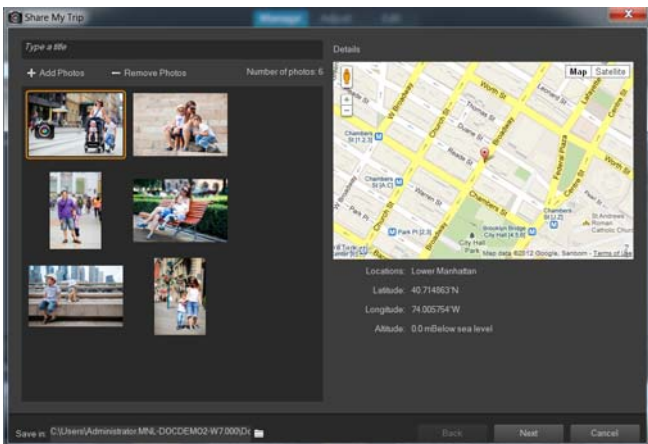

*With Share My Trip, you can create interactive slideshows that map your photos by location. You can click a photo on the map to view a larger version of the photo.*



*In the Share My Trip dialog box, you can add a title for your slideshow, view location information, and choose a folder where to save the project.*

## To create a Share My Trip project

- 1 Select the photos that you want to include in your project.  
You can select up to 200 photos. Only photos with location information can be used in the project.
- 2 Click the **Share My Trip** button .
- 3 In the Share My Trip dialog box, click **Type a title**, and type a title for the project.  
If you don't type a title, the project will be named My Trip.
- 4 Type a location for the project in the **Save in** box, or click the folder icon to browse for a folder where you want to save the project.
- 5 Click **Next**.
- 6 Click the **Preview In Browser** button  to preview the project in your browser.

7 Enable one of the following check boxes:

- **Yes, upload my photo map to a public Dropbox folder.**
- **No, I will share it later.**

Choose the second option if you want to post the HTML output yourself (for example, in a blog).

If you choose to upload to Dropbox and want to post the Dropbox link on Facebook, enable the **Share the link on Facebook** check box, and choose a thumbnail.



If you are not currently logged into Dropbox and Facebook, you will be prompted to log in before uploading and sharing the project.

If you are unable to upload to Dropbox, please check the size of your project and review the upload and account size limit for your Dropbox account ([www.dropbox.com](http://www.dropbox.com)).



You can also click **Add Photos** or **Remove Photos** to add or remove selected photos.



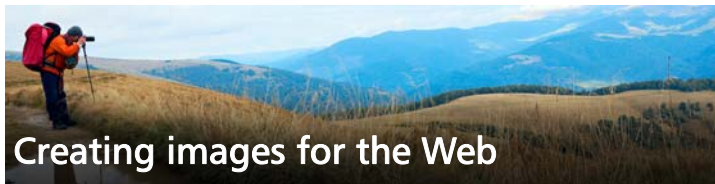

You can save and optimize images for the Web to reduce the image file size and make images load more quickly. Using the Web tools, you can create backgrounds for your Web pages, and map and slice images to create hotspots or rollovers. You can also protect your images by adding watermarks with creator and copyright information.

This section presents the following topics:

- Saving images for the Web
- Working with GIF files
- Working with JPEG files
- Working with PNG files
- Previewing images in Web browsers
- Slicing images
- Mapping images
- Creating image rollovers
- Using digital watermarks
- Adding visible watermarks

## Saving images for the Web

Because the majority of Web browsers recognize GIF and JPEG images, these two formats are used most often for saving Web images. Newer versions of the Web browsers can also recognize the more recent PNG

format, and many Web browsers also support Wireless Bitmap (WBMP) and i-mode formats, which are popular formats for wireless devices.

When you save images for the Web, there are three major considerations: layers, color depth, and file size.

## Layers

Because none of the current Web browsers can display layered images, you need to flatten an image before saving it for the Web.

## Color depth

Some computers can display no more than 256 colors. If an image on a Web page contains more colors, the Web browser uses its own dithering method to display the image. This can produce color distortion. If you reduce the color depth of the image to 8 bits (256 colors) before placing it on your Web page, its appearance will be more consistent. For more information about color depth, see “Working with advanced color features” on page 629.

## Web file formats and file sizes

File size affects the majority of users accessing a Web page. As the size of an image file increases, it takes more time to download, so viewers have a longer wait. You should use a file format that reduces the image size while keeping the quality as high as possible.

Choose from the following file formats when saving images for use on the Web:

- **GIF** — this format compresses line art and images with areas of similar colors. It supports 8-bit (256) color. There are two versions of GIF: 89a, which can save transparency and information, and

87a, which cannot. Both are recognized by most browsers and use lossless compression.

- **JPEG** — this format efficiently compresses photographic images. It supports 24-bit (16.7 million) color, uses lossy compression, and is recognized by most browsers.
- **PNG** — this increasingly popular format efficiently compresses images. It supports up to 24-bit (16.7 million) color and uses lossless compression. It is not as widely used as JPEG, so some features of this format are not available for older browsers.
- **Wireless Bitmap (WBMP)** — this format is used with many wireless devices. The images are black and white and have lossless compression.

### What's the difference between lossy and lossless compression?

Lossy compression is a compression method that eliminates data to reduce the file size. Lossless compression retains all of the original image data and reduces the file size by storing patterns of pixels in the image.

### To flatten an image

Edit workspace

- Choose **Layers ▶ Merge ▶ Merge All (Flatten)**.

### Working with GIF files

Corel PaintShop Pro lets you optimize GIF files to maximize quality while minimizing file size. You can save images with or without transparency, depending on how you want to display them on your Web pages.

Paletted images (those with 256 or fewer colors, such as GIF or PNG files) do not support transparent backgrounds, but you often need to

make part of your image transparent for a Web page. For example, you may have a round logo and want to display the background of the Web page around the logo. In this case, you can choose not to display one color. Most Web browsers support this option, effectively making that color transparent.

The GIF Optimizer dialog box contains four tabbed areas in which to configure the transparency, color, and format options of the file. The fifth tabbed area displays estimated download times of the image at various modem speeds.

### **GIF Optimizer Transparency**

You can choose to base transparency on existing image or layer transparency, or you can sample a color in the image that you want to make transparent. If you have a selection in your image, you can base the transparency on the selection.

### **GIF Optimizer Partial Transparency**

A GIF file cannot contain partially transparent pixels. All pixels must be either transparent or opaque (visible). Original images may contain partially transparent pixels if the image does not have a background layer, and you have reduced the opacity of a layer, added a mask, feathered a selection, or used a brush at a reduced opacity setting. You can determine whether the partially transparent pixels become transparent or opaque, and whether they are blended with another color.

***Important!** If you mark the **None** option under the Transparency tab, the options in this area are unavailable.*

### **GIF Optimizer Colors**

GIF images have an 8-bit color depth, which means they can display up to 256 colors. Because these colors are stored in a palette, an image

containing 256 or fewer colors is called a paletted image. To reduce file size, you can have fewer than 256 colors. You can use the options under this tab to select the number of colors and the type of palette used.

## **GIF Optimizer Format**

GIF images can be interlaced or non-interlaced, which affects how the image is displayed on a computer with a slow Internet connection. You can also save the image to an older version of the GIF format to enhance compatibility with older applications.

## **GIF Optimizer Download Times**

The Download Times tabbed area in the GIF Optimizer dialog box displays the size of the compressed file and estimated download times for four different Internet speeds. If the file size is too large, you can decrease it by reducing the number of colors.

## **Using the Transparent GIF wizard**

You can open the Transparent GIF wizard from the GIF Optimizer dialog box. This wizard guides you through the steps of optimizing a GIF file.

## **What is interlacing?**

Interlacing is a method that lets you display a Web-based image on the screen at a low, blocky resolution. As the image data loads, the image quality improves.

## **To optimize and save a GIF file**

*Edit workspace*

- 1 Choose **File** ▶ **Export** ▶ **GIF Optimizer**.

The GIF Optimizer dialog box appears, and the preview areas show the current image on the left and the resulting GIF file on the right.

- 2 Click the **Transparency** tab, and choose one of the following options:
  - **None** — produces a GIF file that does not use a transparency setting
  - **Existing image or layer transparency** — uses the current transparency information from the image
  - **Inside the current selection** — for images with a selection, makes everything within the selection transparent
  - **Outside the current selection** — for images with a selection, makes everything outside the selection transparent
  - **Areas that match this color** — bases the transparency on a color you select. Click the color box to select a color or choose a color from the image by moving the cursor over the image, and clicking a color. Then set or type a tolerance factor in the **Tolerance** control to determine how closely colors must match the selected color before they become transparent.
- 3 Click the **Partial Transparency** tab and choose one of the following options:
  - **Use full transparency for pixels below x% opacity** — determines the opacity value at which pixels become transparent. Pixels below the opacity value you set become transparent. Pixels above the opacity value become opaque. As you lower the value, you reduce the number of transparent pixels.
  - **Use a 50% dither pattern** — makes partially transparent pixels opaque using either the color chosen for blending or the image color (depending on the blending option), then applies a 50% dither pattern to make colors look more natural

- **Use error diffusion dither** — makes partially transparent pixels opaque using either the color chosen for blending or the image color (depending on the blending option), then applies an error diffusion dither to make colors look more natural
- 4 Choose one of the following options to determine how partially transparent pixels are blended:
    - **Yes** — blends the partially transparent pixels with the color in the Blend color box. To choose a new color, click the color box, and choose a color from the Color dialog box. Partially transparent pixels below the value you set above are blended with this color.
    - **No** — uses the existing image color at 100% opacity

- 5 Click the **Colors** tab, and type or set a value in the **How many colors do you want?** control to determine the number of colors you want in the image.

**Note:** As you remove colors, the size of the file decreases, but so does the quality of the image. Use the preview areas to help you determine the best balance between file size and image quality.

- 6 Type or set a value in the **How much dithering do you want?** control.

The range is 16 to 256 colors. This determines the way Corel PaintShop Pro arranges pixels in an image to compensate for missing colors in the adjacent pixels.

- 7 Choose one of the following options to determine the image palette:
  - **Existing Palette** — lets you use an existing image palette
  - **Standard/Web-safe** — lets you use the Web-safe palette for images that you want to use on the Web
  - **Optimized Median Cut** — lets you reduce the image to only a few colors. If you choose this option, you can mark the **Boost selected colors** check box to give the colors more weight by a

factor of the value you set. The selected colors stand out from the rest of the image. To boost colors, make a selection of an area that contains these colors and then mark this check box.

- **Optimized Octree** — lets you optimize an image that contains only a few colors

**Note:** Depending on your needs, you may want to try both the Optimized Median Cut and the Optimized Octree options and choose the one that gives you the best results.

- 8 In the Options group box, mark the **Include Windows colors** check box to include the 16 standard Windows colors in the palette.

If the image will be used on the Web, mark the check box.

- 9 Click the **Format** tab, and choose one of the following options:

- **Non-interlaced** — produces an image that downloads one line at a time, starting from the top
- **Interlaced** — produces an image that is displayed incrementally in several passes, and detail is added each time

**Note:** Choose the Interlaced option with larger images so that the viewer can get an idea of how the image looks while waiting for it to download.

- 10 Choose one of the following options:

- **Version 89a** — lets you save transparency information. It is selected automatically if the image contains transparent pixels.
- **Version 87a** — lets you save an image that does not contain a transparency setting

- 11 Click **OK** to open the Save As dialog box, and navigate to the folder in which you want to save the new image and type a name for the file.

- 12 Click **Save**.



## To use the Transparent GIF wizard

Edit workspace

- 1 Choose **File** ▶ **Export** ▶ **GIF Optimizer**.

The GIF Optimizer dialog box appears.

- 2 Click **Use wizard**, and follow the instructions.
- 3 Click **Finish** to close the wizard and open the **Save As** dialog box, where you type a name and select a location for saving the GIF file.

### You can also

Choose a color within the image	On page 1 or 2 of the wizard, move the cursor over the image, and click a color. The color swatch displays the color you clicked.
Choose a color using the Color dialog box	On page 1 or 2 of the wizard, click the color swatch to open the Color dialog box. For more information about the controls in the Color dialog box, see “To choose a color from a dialog box” on page 46.
Change a setting	On page 5 of the wizard, click <b>Back</b> to return to the previous pages, change the settings you want, and return to page 5 to view the results.



A GIF image cannot contain partially transparent pixels. If the image contains them, the Transparent GIF wizard blends them with the color you choose. Reducing layer opacity, adding a mask, feathering a selection, and using a brush set at reduced opacity are some of the actions that can produce partially transparent pixels.



You can click the **Download Times** tab to preview the file size of the compressed file and view an estimate of the download time at four modem speeds.

## Working with JPEG files

Corel PaintShop Pro lets you optimize JPEG files to maximize image quality and minimize file size.

***Important!** Each time you open and save a JPEG file, image data is discarded. It is a good idea to keep a copy of the original image.*

### JPEG Optimizer Quality

You can use compression to reduce the size of the JPEG file. When you compress a JPEG image, you delete image information. As you increase the compression, you lower the quality of the image. You can use the image preview area to help you find the best balance between file size and image quality.

You can also reduce the file size with chroma subsampling, which averages the color information for every  $2 \times 2$  square of pixels. You can change this setting to have a larger area of color information averaged.

### JPEG Optimizer Background Color

The Background Color tabbed area in the JPEG Optimizer dialog box is available if an image has transparent areas. You can determine how transparent pixels in your image are blended with a background by choosing a background color. For example, if you are placing an image on a Web background, you can select the same background color in the JPEG Optimizer to ensure the image blends seamlessly with the Web page.

## JPEG Optimizer Format

You can determine how an image appears as it is being loaded. You can optimize the JPEG so that the image downloads one line at a time, starting from the top.

You can choose to have large images displayed incrementally in several passes; detail is added with each pass. This option allows the viewer to see the image as it is being downloaded.

## JPEG Optimizer Download Times

You can view the size of the compressed file and estimated download times for four modem speeds.

## Using the JPEG wizard

You can open the JPEG wizard from the JPEG Optimizer dialog box. This wizard guides you through the steps of optimizing a JPEG file.

## To optimize and save a JPEG file

*Edit workspace*

- 1 Choose **File ▶ Export ▶ JPEG Optimizer**.  
The JPEG Optimizer dialog box appears. The preview areas show the current image on the left and the resulting JPEG file on the right.
- 2 Click the **Quality** tab, and set or type a value in the **Set compression value to** control.
- 3 Choose a color sampling method from the **Chroma Subsampling** drop-list if you want to change the default setting.
- 4 Click the **Format** tab and choose one of the following options:
  - **Standard** — downloads one line a time, starting from the top
  - **Progressive** — displays the image incrementally in several passes, and detail is added each time

- 5 Click **OK** to open the Save As dialog box, navigate to the folder in which you want to save the new image, and type a name for the file.
- 6 Click **Save**.



You can click the **Download Times** tab to preview the file size of the compressed file and view an estimate of the download time at four modem speeds.

## To use the JPEG wizard

Edit workspace

- 1 Choose **File** ▶ **Export** ▶ **JPEG Optimizer**.  
The JPEG Optimizer dialog box appears.
- 2 Click **Use wizard** and follow the instructions.

## Working with PNG files

Corel PaintShop Pro lets you optimize PNG files to maximize quality and minimize file size.

The PNG Optimizer dialog box contains three tabbed areas where you can configure the color, transparency, and format options of the file. The fourth page displays estimated download times of the image at various modem speeds.

### PNG Optimizer Colors

You can choose the color depth for the PNG file — the greater the color depth, the longer it takes to download the image. The controls under the Colors tab of the PNG Optimizer dialog box let you select a color depth for your PNG image. For paletted images, you can select the method of color reduction, number of colors, and amount of dithering.

## PNG Optimizer Gamma

PNG images contain a gAMA chunk, which controls gamma levels of an image. The gamma setting helps the image appear consistent across multiple display devices. If in doubt, you should use the default PC value.

## PNG Optimizer Transparency

You can choose to base transparency on existing image or layer transparency, or you can sample the color in the image that you want to make transparent. If you have a selection in your image, you can base the transparency on the selection. You can also base transparency on the alpha channel.

## PNG Optimizer Format

PNG images can be interlaced or non-interlaced, which affects how the image is displayed on a computer with a slow Internet connection.

## PNG Optimizer Download Times

The size of the compressed file and an estimate of the download time at four modem speeds are displayed under the Download Times tab of the PNG Optimizer dialog box.

## Using the PNG wizard

You can open the PNG wizard from the PNG Optimizer dialog box. The wizard guides you through the steps of optimizing a PNG file.

## To optimize and save a PNG file

Edit workspace

- 1 Choose **File** ▶ **Export** ▶ **PNG Optimizer**.

The PNG Optimizer dialog box appears. The preview areas show the current image on the left and the resulting PNG file on the right.

- 2 Click the **Colors** tab, and choose one of the following image type options:

- **Palette-Based** — for images with 256 colors or less
- **Grayscale (8-bit)**
- **16.7 million color (24-bit)**

If you choose the Palette-Based method, you can choose the number of colors in the image and the amount of dithering applied.

- 3 Click the **Transparency** tab, and choose one of the following transparency types:

- **No transparency** — saves the image without transparency
- **Single color transparency** — lets you make one color transparent by clicking a color swatch or clicking a color in the image, and entering a value in the **Tolerance** control.
- **Alpha channel transparency** — uses the current selection or alpha channel transparency of the image. You can choose which part of the image will be transparent by choosing **Existing image or layer transparency**, **Existing alpha channel transparency**, **Inside the current selection**, or **Outside the current selection** option.

- 4 Click the **Gamma** tab, and set or type a value in the **Gamma** control if you want to change the default value.

- 5 Click the **Format** tab, choose one of the following options:

- **Non-interlaced** — the image downloads one line at a time, starting from the top
- **Interlaced** — the image is displayed incrementally in several passes; detail is added with each pass. Use this option with

larger images so that the viewer can get an idea of how the image looks while waiting for it to download

- 6 Click **OK** to open the Save As dialog box, navigate to the folder in which you want to save the new image, type a name for the file, and click **Save**.



You can click the **Download Times** tab to preview the file size of the compressed file and an estimate of the download time at four modem speeds.

## To use the PNG wizard

Edit workspace

- 1 Choose **File** ► **Export** ► **PNG Optimizer**.  
The PNG Optimizer dialog box appears.
- 2 Click **Use wizard** and follow the instructions.
- 3 Click **Finish** to close the wizard and open the Save As dialog box, where you type a name and select a location for saving the GIF file.

### To

### Do the following

Choose a color within the image	On page 2 or 3 of the wizard, move the cursor over the image, and click a color. The color swatch displays the color you clicked.
Choose a color using the Color dialog box.	On page 2 or 3 of the wizard, click the color swatch to open the Color dialog box.
Change a setting	On page 6 of the wizard, click <b>Back</b> to return to the previous pages. Then, change the settings you want, and return to page 6 to view the results.

## Previewing images in Web browsers

You can use your Web browser to see how your active image will look on the Web. Corel PaintShop Pro creates an HTML page that displays your image in Windows Bitmap, GIF, JPEG, or PNG format. You can select up to three browsers. For information about adding, changing, or deleting Web browsers that you use for previewing, see “Selecting Web browsers” on page 698.

### To preview image files in Web browsers

Edit workspace

- 1 Choose **View ▶ Preview in Web Browser**.

The Preview in Web Browser dialog box opens.

- 2 In the Select Image Formats list, click each format in which you want to preview your image.
- 3 Do one of the following to select a background color for the Web page:
  - Click the **Background color** box, and choose a color from the Color dialog box.
  - Right-click the **Background color** box, and choose a recently used color.
- 4 In the Image Size group box, do one of the following:
  - Mark the **Use default** check box to keep the original image dimensions.
  - Unmark the **Use default** check box and type or set new image dimensions (in pixels) in the **Width** and **Height** controls.
- 5 Click **Preview**.

If you choose only **Windows Bitmap** in the Select Image Formats list, the program opens the Web Browser and displays the image.



If you selected any other format, the program opens the appropriate optimization dialog box. Select your choices for optimizing the image, and click **OK**.



For each format, the browser displays the file size, color depth, and approximate download times at the bottom of the image.

## Slicing images

When you slice an image, you divide it into several smaller images that you can save in different formats or at different levels of optimization. Because these optimized images can take less time to download than one large image, your Web pages may load more quickly.





Slicing an image also can reduce the number of graphics you need to save. If your website displays the same logo or other graphic in more than one image, you only need to save that section once if you slice the images; you reload the same logo or graphic section into all the images.

Using the Image Slicer, you can create a table from the image, saving the location of each sliced section as a region in the table, and generating the HTML code for the column and cells. Then, you copy this code into your source files so that the image can be reassembled when the user downloads the Web page.

You can also create rollovers, which are areas that display secondary images when the user clicks or moves a mouse over them.

### Creating and editing cells

When slicing an image, you divide it into cells and edit the cell boundaries. You do this with the tools in the Tools groups box of the Imager Slicer dialog box.

Tool	Description
	The <b>Arrow</b> tool lets you make a cell active or move its borders.
	The <b>Grid</b> tool lets you create a grid of evenly spaced cells, either over the entire image or within another cell.
	The <b>Slicer</b> tool lets you create a horizontal or vertical line.
	The <b>Delete</b> tool lets you delete slice lines.
	The <b>Pan</b> tool lets you drag the image in the preview to view hidden areas of the image.

## Assigning sliced cell properties

After you have created sliced cells, you can assign URLs, alternate text, and targets to each cell. You also have the option to have the cell appear in the downloaded image. By omitting cells, you can add cells from other images (such as logos or text) and create images in nonrectangular shapes.

When you assign alternative text, the text is displayed while the image is loading. The text is also displayed if the image cannot be downloaded, or if the user has images disabled in the Web browser. In some versions of Internet Explorer, this text also appears as a tooltip.

## Setting slice preferences

You can select colors for the border lines of the active and inactive areas.

## Saving and loading slice settings

When you save the slice settings, you save the cell arrangement and the information you typed in the Image Slicer dialog box. You can then reload them into the same image or use them with a different image.

## Saving slices

You can save slices to a folder on your hard drive so that you can reuse or edit them.

## To slice an image into cells

Edit workspace

- 1 Choose **File** ▶ **Export** ▶ **Image Slicer**.

The Image Slicer dialog box appears.

- 2 Choose the **Slice** tool  and click in the image where you want create a slice line.

**Note:** To create a vertical line, drag vertically; to create a horizontal line, drag horizontally.

- 3 Choose the **Arrow** tool  and click inside the cell to make it active.

The cell boundary information is displayed in the lower portion of the Cell Properties group box.

- 4 In the **URL** drop-list, type the address of the Web page where you want the cell to appear.

If you want to select addresses already used in the image, select the address you want from the **URL** drop-list.

- 5 In the **Alt text** box, type text that the browser can display while the cell is downloading.

- 6 Choose one of the following target frames or window options from the **Target** drop-list:

- **\_blank** — loads the linked page in a new browser window
- **\_parent** — loads the linked page in the parent window or frameset of the link. If the link is not in a nested frame, the image loads in the full browser window.
- **\_self** — loads the linked page in the same window or frame as the link

- **\_top** — loads the linked page in the full browser window and removes all frames

7 Click **Save**.

The HTML Save As dialog box appears.

8 Navigate to the folder where you want to save the HTML code and click **Save**.

## You can also

---

Create cells with consistent spacing and size.

Click the **Grid** tool . Click in the preview area to open the Grid Size dialog box, and type or set values in the **Rows** and **Columns** controls.



---

Move a slice line or border

Click the **Arrow** tool , and move the cursor over a line. When the cursor changes to the double-sided arrow, drag the line to a new position. To move only the segment within the current cell, hold down **Shift** while clicking the line.

---

Delete a line or border

Click the **Delete** tool , and move the cursor over the line. When the cursor changes to an eraser-shape, click to delete the line. If deleting the line would create an invalid area, Corel PaintShop Pro displays an icon  to indicate that you cannot erase the line.

---

Omit a cell from the downloaded image

Click the cell with the **Arrow** tool, and unmark the **Include cell in table** check box.

---

## You can also

---

Save slice settings to the Clipboard so you can paste them into the HTML code	Click <b>Save to Clipboard</b> to open the HTML Destination Folder dialog box, navigate to the folder where the HTML file is saved, and click <b>OK</b> to save the slice settings. Open the HTML file, place the cursor where you want to insert the HTML slice code, and press <b>Ctrl + P</b> .
Create a rollover for a cell	Click <b>Rollover Creator</b> . For more information about creating image rollovers, see “Creating image rollovers” on page 783.

---



You can move lines up, but not across, adjacent parallel lines. You can move individual lines and lines that are part of a grid. As you drag a line, Corel PaintShop Pro moves the longest segment that can be repositioned without creating a non-rectangular cell.

## To set slice preferences

Edit workspace

- 1 In the Image Slicer dialog box, click **Preferences**.
- 2 Click the **Active tile border color** color box, and choose a color.
- 3 Click the **Inactive tile border color** color box, and choose a color.
- 4 In the **Maximum history list size** control, type or set the number of entries listed in the **URL** and **Alt text** drop-lists in the Cell Properties group box in the Image Slicer dialog box.
- 5 Click **OK**.



If you want to be prompted for a file location and name for your slices when you save the HTML code, mark the **Prompt for image folder on Save or Save As** check box.

## To save slice settings

Edit workspace

- 1 In the Image Slicer dialog box, click **Save Settings**.  
The Save Slice Settings dialog box appears.
- 2 Navigate to the folder in which you want to save the settings file.
- 3 Type a name for the file and click **Save**.  
The file is saved in the JSD format.

## To load slice settings

Edit workspace

- 1 In the Image Slicer dialog box, click **Load Settings**.  
The Load Slice Settings dialog box appears.
- 2 Select the JSD file you want to load, and click **Open**.









If you are loading a grid to a different image, Corel PaintShop Pro automatically adjusts the grid size if the dimensions of the image are not the same.

## Mapping images

An image map is a graphic that contains a mapped area (called a region or hotspot), that links to a URL. The cell can be a circle, rectangle, or irregular shape. When you move the mouse over the cell, the cursor changes to a hand indicating that you can click that area to jump to another Web page.

## Creating map areas

You create and edit image map areas with the tools in the Tools group box of the Image Mapper dialog box.

Tool	Description
	The <b>Arrow</b> tool lets you modify a hotspot area.
	The <b>Mover</b> tool lets you move a hotspot area.
	The <b>Polygon</b> tool lets you create an irregular-shaped hotspot area.
	The <b>Rectangle</b> tool lets you create a square or rectangular hotspot area.
	The <b>Circle</b> tool lets you create a circular or elliptical hotspot area.
	The <b>Delete</b> tool lets you delete a hotspot area.
	The <b>Pan</b> tool lets you drag the image in the preview to view hidden areas of the image.

## Assigning map area properties

After you have created the map areas (or regions), you can assign URLs, alternate text, and targets.

## Saving image maps

You can save image maps to a folder on your hard drive so you can use or edit them. You can also save map settings to the Clipboard and then paste them into the HTML code. When you save the map settings, you save the map area arrangement and the information you typed in the Image Mapper dialog box. You can then reload them into the same image, or use the settings with a different image.

## Setting map preferences

After you have created the map areas (or regions), you can assign URLs, alternate text, and targets.



### To create and save a map area

Edit workspace

- 1 Choose **File** ▶ **Export** ▶ **Image Mapper**.

The Image Mapper dialog box appears.

- 2 Choose one of the following tools and draw in the preview area to create a hotspot:

- **Rectangle** tool  — drag the cursor to enclose a square or rectangular-shaped hotspot area
- **Circle** tool  — drag the cursor to enclose a circular or elliptical hotspot area
- **Polygon** tool  — click to set the starting point and continue moving the cursor and clicking to enclose an irregular-shaped hotspot area. Double-click to complete the polygon.

- 3 In the **URL** drop-list, type the address of the Web page to which you want to link.

If you want to select addresses already used in the image, click the arrow in the box and select the address you want from the **URL** drop-list.

If you do not want to link to a Web page, type **#**.

- 4 In the **Alt text** box, type the text that appears if the image does not load or if the user has images disabled in the Web browser.
- 5 Choose one of the following target frame options from the **Target** drop-list:
  - **\_blank** — loads the linked page in a new browser window



- **\_parent** — loads the linked page in the parent frameset of the link. If the link is not in a nested frame, the image loads in the full browser window.
- **\_self** — loads the linked page in the same frame as the link
- **\_top** — loads the linked page in the full browser window and removes all frames

6 Click **Save**.

The HTML Save As dialog box appears.

7 Navigate to the folder where you want to save the HTML code, and click **Save**.

The Image Map Save As dialog box appears.

8 Navigate to the folder where you want to save the image and click **Save**.

### You can also

---

Select an existing map area

Click the **Arrow** tool , and click a map area.

---

Change the shape or size of a map area

Click the **Arrow** tool, click the shape to select it, and hover over one of the green points that appear until the cursor changes to a four-point arrow. Drag the point to a new position.

---

Move the map area

Click the **Move** tool , click inside the map area, and then drag it to a new position.

---

Erase a map area

Click the **Delete** tool  and then click inside the map area.

---

Remove all map areas

Click **Clear**.

---

## You can also

---

Preview the image map in a Web browser

Click the **Preview in browser** button  and test the map area in the Web browser.

---

Save map area information to the Clipboard so that you can paste it into the HTML code

Click **Save to Clipboard** to open the HTML Destination Folder dialog box, navigate to the folder where the HTML file is saved, and click **OK** to save the slice settings. Then, open the HTML file, place the cursor where you want to insert the HTML slice code, and press **Ctrl + V**.

---

Create a rollover for a map area

Click **Rollover Creator**. For more information about creating image rollovers, see “Creating image rollovers” on page 783.

---

## To set map preferences

Edit workspace

- 1 In the Image Mapper dialog box, click **Preferences**.  
The Map Preferences dialog box appears.
- 2 Click the **Active tile border color** box, and choose a color.
- 3 Click the **Inactive tile border color** box, and choose a color.
- 4 In the **Maximum history list size** control, set or type the number of entries listed in the **URL** and **Alt text** drop-lists in the Cell Properties group box in the Image Mapper dialog box.
- 5 Click **OK**.

## To save map settings

Edit workspace

- 1 Click **Save Settings**.  
The Save Map Settings dialog box appears.

- 2 Navigate to the folder in which you want to save the settings file.
- 3 Type a name for the file and click **Save**.  
The file is saved in the JMD format.

## To load map settings

Edit workspace

- 1 Open the image in which you want to load map settings.
- 2 Choose **File ▶ Export ▶ Image Mapper**.  
The Image Mapper dialog box appears.
- 3 Click **Load Settings**.  
The Load Map Settings dialog box appears.
- 4 Navigate to and select the JMD file you want to load.
- 5 Click **Open**.

## Creating image rollovers

A rollover is an image or section of an image that changes appearance when the user activates it. Web designers frequently create rollovers for the buttons of a navigation bar. When a user clicks a button, the browser displays the linked Web page (or file), and the rollover area displays a different button.

You can assign a rollover to an image that is sliced and mapped by choosing an image file that will appear when the user performs a specific mouse action.

## To create image rollovers

Edit workspace

- 1 Create the image to be used as the rollover image. Often this second image is a duplicate of the original, but modified to appear differently when the mouse rolls over the original image.

- 2 Do one of the following:
  - Choose **File** ▶ **Export** ▶ **Image Mapper**.
  - Choose **File** ▶ **Export** ▶ **Image Slicer**.

**Note:** If necessary, navigate to an image region, and use the appropriate tool (for example, the Polygon, Rectangle, or Circle tool) to specify the region where you want to add a rollover.

- 3 Click **Rollover Creator**.

The Rollover Creator dialog box appears.

- 4 Mark any of the following check boxes to determine which actions activate the rollover:
  - **Mouse over**
  - **Mouse out**
  - **Mouse click**
  - **Mouse double-click**
  - **Mouse up**
  - **Mouse down**

- 5 Click the **Open** button .

The Select Rollover dialog box appears.

- 6 Navigate to and select the graphics file you want to use.

If you do not select a file, then the original file is used.

- 7 Click **Open**.

In the Rollover Creator dialog box, the file path appears in the box beside the check box.

- 8 Click **Cancel** to return to the Image Mapper or Image Slicer dialog box.



You can view your work in a Web browser window by clicking the **Preview in browser** button .

## Using digital watermarks

A digital watermark is a permanent proof of authenticity for an image. While a computer can detect it, it is invisible to the viewer. A watermark contains information about the creator, the copyright, and the image. When a viewer chooses to see this information, the program opens a dialog box that contains a link to the Digimarc web page.

### Reading a digital watermark

Whenever Corel PaintShop Pro opens an image, it automatically checks for a digital watermark. If one is detected, the program displays a copyright symbol in front of the filename on the title bar, and the Watermark Information dialog box appears. If Corel PaintShop Pro does not detect a watermark, it displays a message stating that no watermark was found. You can also view the Digimarc database page to get information about the creator.

### Embedding a digital watermark

A digital watermark can only be embedded on a layer once since this prevents its quality from being degraded by further changes to the layer. If you try to embed a watermark in a layered image, Corel PaintShop Pro displays a message recommending that you flatten the image before proceeding.

When you embed a watermark, you can select the following options:

- creator ID
- image copyright dates
- image attributes
- restrictions on use
- watermark durability

You only need to configure the creator ID the first time you embed a watermark. You can change the copyright date, image attributes, and durability each time you embed a watermark.

## Setting the watermark durability

The watermark durability indicates how visible watermarks are on the image. For images to be printed, use stronger watermarks. For images to be displayed on a monitor, use weaker watermarks because they are not as visible. While stronger watermarks are easier to detect, and harder to remove, they are also more visible in the image. You can make two copies of the image and apply a stronger watermark to the copy you are printing and a weaker one to the copy you are displaying electronically.

## Personalizing the Creator ID

Customizing the watermark with your own identification number requires the following two steps:

- Register with Digimarc to obtain your own ID number.
- Type the information in the Personalize Creator ID dialog box.

## To read a digital watermark

Edit workspace

- Choose **Image** ▶ **Watermarking** ▶ **Read Watermark**.



You can view the Digimarc database page to get information about the watermark creator by clicking **Web Lookup** in the Watermark Information dialog box.

## To embed a watermark

Edit workspace

- 1 Choose **Image** ▶ **Watermarking** ▶ **Embed Watermark**.

- The Embed Watermark dialog box appears.
- In the Image Attributes group box, mark any of the following check boxes to determine the restrictions shown when the program displays the watermark information:
    - **Restricted use**
    - **Do not copy**
    - **Adult content**
  - In the Copyright Information group box, type either one or two years in the **Copyright year(s)** boxes.  
Digimarc accepts years from 1922 to the present.
  - Click **OK**.



A layer can contain only one watermark. You cannot embed a new watermark in a layer that already contains one.

## To set the watermark durability

Edit workspace

- Choose **Image ▶ Watermarking ▶ Embed Watermark**.

The Embed Watermark dialog box appears.

- From the **Target Output** drop-list, choose the medium in which the image is to be displayed:

- **Monitor**
- **Print**

If you select **Print** for an image with a resolution under 300 dpi, Corel PaintShop Pro displays a message recommending that you increase the image resolution before embedding the watermark.

- To set the watermark strength, type a number from 1 to 16, or use the default values in the **Watermark durability** control.

The default for the Monitor option is 8 and for the Print option is 12.

- 4 To verify that the watermark information is embedded correctly, mark the **Verify** check mark.

The program checks that the watermark has been applied and displays its attributes and durability.

## To personalize the Creator ID

Edit workspace

- 1 Choose **Image ▶ Watermarking ▶ Embed Watermark**.

The Embed Watermark dialog box appears.

- 2 Click **Personalize**.

The Personalize Creator ID dialog box appears.

- 3 To register with Digimarc, click **Register**.

Your Web browser opens and navigates to the Digimarc Web page. Follow the on-screen instructions to receive a Creator ID number, a PIN number, and a password. You should write them down for later use. Close the browser to return to the Personalize Creator ID dialog box.

- 4 Type the PIN and Creator ID numbers in the appropriate boxes.

- 5 Click **OK**.

The Embed Watermark dialog box appears.

- 6 Click **OK**.

If the **Verify** check box is marked, the Embed Watermark: Verify dialog box appears. It lets you know that the watermark has been embedded and displays the creator, copyright, image attribute, and durability information from the Embed Watermark dialog box.



If your computer does not have Web access, phone Digimarc using the toll-free number to register and receive your Creator ID number, a PIN number, and a password.



## Adding visible watermarks

You can place a visible watermark consisting of text and/or a graphic on any raster image. Whether you take professional photos or just share photos on public websites, adding a discrete mark to your photos reminds viewers who took the shot. This feature simplifies the task of adding a logo or other graphic, and you can choose from professional effects like embossing to give it a subtle look.

You may find that the watermark graphic looks better when you create it with a transparent background. If so, you'll need to save the graphic in a file format that supports transparency (such as PsdImage, TIF, or PNG). You can use images that do not have a transparent background, but be aware that the watermark will display a rectangle around it, although you can adjust the opacity of the overall graphic.

### To add a visible watermark

Edit workspace

- 1 Choose **Image** ▶ **Watermarking** ▶ **Visible Watermark**.

The Visible Watermark dialog box appears.

- 2 In the **Watermark Source** group box, click the **Browse** button. Use the Open dialog box to navigate to the folder containing the graphic you want to use for the watermark.

The graphic appears in the preview area of the Watermark Source group box.

- 3 In the **Placement** group box, choose a placement option:
  - **Tile** — places the graphic in rows and columns that cover the image
  - **Center** — places the graphic in the center of the image
  - **Corner** — lets you choose the image corner in which the graphic is placed

- 4 In the **Style** group box, adjust the overall appearance of the graphic:
  - **Size** — lets you adjust the size of the graphic
  - **Opacity** — lets you adjust the graphic's opacity. Increasing the Opacity setting allows more of the underlying image to be seen through the graphic.
  - **Emboss** — applies a raised appearance to the graphic
- 5 Click **OK**.

# Index

## Numerics

1-bit color depth 633

decreasing images to 635

2 colors

decreasing images to 635

3D effects 420

Buttonize 420

Chisel 421

Cutout 421

Drop Shadow 422

Inner Bevel 423

Outer Bevel 425

4-bit color depth 634

decreasing images to 636

8-bit color depth 634

decreasing images to 637

increasing images to 632

8-bit grayscale color depth 634

decreasing images to 638

16 colors

decreasing images to 636

increasing images to 632

16-bit color depth

increasing images to 632

24-bit color depth 634

decreasing images to 638

256 colors

decreasing images to 637

increasing images to 632

32K colors

decreasing images to 638

32-bit 4

64K colors

decreasing images to 638

64-bit 4

## A

actions

automating 677

disabling in scripts 717

removing from scripts 717

actions, recording scripts 705

Adjust workspace 11, 26, 140

adjusting images 149

automatically 166

in one step 168

- with advanced techniques 169
  - with Smart Photo Fix 168
- adjustment layers 359**
- adding 359
  - displaying overlays 360
  - editing 360
  - hiding overlays 360
- Advanced Creator Information dialog box 78**
- Aged Newspaper effect 431**
- Airbrush tool 36, 594, 597**
- albumen photos 488**
- aligning**
- text 537
  - text on paths 540
  - vector objects 572
  - vector objects to canvas 574
- alpha channels**
- deleting 324
  - loading masks from 380
  - loading selections from 322
  - renaming 322
  - saving masks to 383
  - saving selections to 321
  - setting PNG preferences for 688
- angles, straightening 164**
- animating, menus 662**
- anti-aliasing**
- Bézier curves 588
  - edges of preset shapes 561
  - edges of rectangles 556
  - edges of squares 556
  - freehand curves 589
  - lines 583
  - PostScript files 689
  - recovering 317
  - selections 316
  - selections based on shape 316
- anti-aliasing, text 539**
- application preferences**
- resetting 700
  - setting miscellaneous 678
- Arithmetic command 517**
- combining images with 517
- arranging**
- image windows 50
  - images in print layouts 743
  - vector objects 572
- Arrow tool**
- using with image maps 779
  - using with image slices 774
- Art Eraser tool 628**
- setting options for 628

- Art Media effects 427**
  - Black Pencil 427
  - Brush Strokes 427
  - Charcoal 428
  - Colored Chalk 429
  - Colored Pencil 430
  - Pencil 430
- Art Media layers 608**
  - creating 608
  - drying or wetting 608
  - modifying properties 609
- Art Media tools 614**
  - adjusting brush size 616
  - creating photo-art with 616
  - drawing with 607
  - painting with 607
  - types of. *See name of specific tool*
- artifacts, removing JPEG 207**
- Artistic effects 431**
  - Aged Newspaper 431
  - Balls and Bubbles 432
  - Chrome 436
  - Colored Edges 436
  - Colored Foil 437
  - Contours 438
  - Enamel 439
  - Glowing Edges 440
  - Halftone 441
  - Hot Wax Coating 442
  - Magnifying Lens 442
  - Neon Glow 445
  - Posterize 446
  - Solarize 446
  - Topography 447
- artistic renderings 616**
- aspect ratio, maintaining**
  - for preset shapes 561
- assigning keyboard shortcuts 667**
- associating file formats 690**
- asymmetrical nodes 564**
- attaching**
  - photos to e-mails 749
  - text to paths 541
- Auto Selection tool 35, 294**
- autochromes 489**
- automating**
  - actions 677
  - basic photo corrections 166
  - Bézier segment connection 587
  - file format selection 671
  - image window magnification 670
  - image window
    - magnification, reset of 670
  - image window resizing 670

- palette display 674
- scratch removal 205
- tasks 705

**auto-preserving original file**  
683

**autosaving, preferences for**  
699

## **B**

### **background**

- erasing areas from 248, 250
- erasing straight lines from 249
- filling cropped edges with 164
- PostScript, setting to white 689
- printing 732
- promoting layers 340
- restoring erased pixels to 249, 251
- setting tolerance to 679
- swapping with foreground 389

**background color, changing**  
30

**Background Eraser tool** 37

- setting preferences for 245
- switching to 249, 251

**backing up your database** 703

**Balls and Bubbles effect** 432

- applying environment or bump maps with 448

**barrel distortion** 181

- correcting 181

**Batch Merge, HDR** 285

### **batches**

- converting files in 724
- processing files in 723
- renaming files in 727
- running scripts on files in 725

### **Bézier curves**

- choosing line style 588
- connecting segments automatically 587
- drawing 586
- setting line width 588
- smoothing 588

**Bicubic resampling method**  
223

**Bilinear resampling method**  
223

**Black and White Film effect**  
480

**black and white, converting to**

- by adjusting threshold 197
- by choosing 8-bit grayscale color depth 638

**Black Pencil effect** 427

- blemishes, removing 234
- blend modes 350
  - types of 350
- blend ranges 350
  - setting 355
- blending
  - edges 243
  - layers 350
  - pigments 615, 626, 627
  - setting modes for brushes 596
- Blinds effect 499
- blooming, sensor 177
- blurring images
  - commands for 214
  - minimally 215
  - moderately 216
  - radially 216
  - with average 215
  - with Gaussian effect 216
  - with motion effect 216
  - with nearby pixel intensity 215
- blurring, images 214
- bold text formatting 536
- borders, adding
  - to print layouts 743
  - to selections 318
- borders, adding to images 263
- boundaries, smoothing selection 317
- box-camera photos 489
- bracketing 275, 285
- breaking contours 580
- brightening photos
  - with Lighten/Darken tool 254
  - with White slider 170
- brightening shadows 188
- brightening, photos 171
- brightness and contrast
  - adjusting 186
- brightness, adjusting
  - along with contrast and gamma 195
  - for color channels 189
- brush presets
  - creating 604
- Brush Strokes effect 427
- brush tips
  - creating 602
  - creating from selections 603
  - importing 605
  - rotating 596
  - shaping 595
  - sharing 605

sizing 595

**Brush Variance palette 30**

**brushes**

adjusting size 616

building up paint 597

choosing 594

customizing 600

customizing settings 600

displaying cursor size and shape 672

displaying outlines 672

painting continuous color 597

painting with wet look 597

resetting to default settings 598

setting blend modes 596

setting hardness 596

setting options for 595

setting paint rate 597

setting steps 596, 600

setting stroke density 596

setting stroke thickness 596

undoing multiple strokes 599

undoing recent strokes 599

**bump maps 448**

applying 448

**Burn blend mode 354**

**Burn tool 36, 252**

**Buttonize effect 420**

**buttons, toolbar 663**

**C**

**caching**

group layers 672

layers 672

merged image groups 672

merged images 672

setting preferences for 670

**Calendar, finding images 111**

**calibrating**

monitors 651

printers 747

**Camera RAW Lab 144**

and RAW photo settings 145

changing preferences 146

**cancelling script recording 708**

**canvas**

aligning vector objects to 574

clipping selections 306, 323

distributing vector objects 575

moving layers 346

resizing 271

wrapping pixels around 473

**captions**

adding 134



- deleting 134
- print layout 737
- capturing images 79**
- cascading**
  - image windows 50
- categorizing resources 696**
- cells**
  - editing in print layout templates 740
  - slicing images into 773
- centering**
  - eye glints 232
- centerpoints**
  - changing for rotation 269
  - changing for text rotation 550
  - positioning for circles 558
  - positioning for ellipses 558
  - positioning for preset shapes 561
- Chalk tool 38, 619**
  - setting options for 619
- Change to Target tool 37, 253**
- channels**
  - alpha. *See* alpha channels
  - color. *See* color channels
- Charcoal effect 428**
- Chisel effect 421**
- chroma, subsampling 766**
- chromatic aberrations 177**
  - displaying affected image areas 180
  - previewing fixes 180
  - removing 178
- Chrome effect 436**
- Circle effect 466**
- Circle tool 779**
- circles**
  - positioning centerpoints 558
  - setting radii 557
- circles, drawing 557**
- clarity 186, 188, 189**
- Clipboard**
  - creating images from 75
  - emptying 87
  - saving map area information 782
  - setting preferences 679
- clipping selections 303, 323**
  - to canvas 306
- Clone tool 36, 594**
- cloning images 240**
- closing**

- contours 578
  - image windows 49
  - images 62
  - Print Layout window 736
  - CMYK color model 649
    - printing with separations 745
  - code, editing 717, 718
  - collage 326
  - collages, creating from photos 332
  - collapsing layer groups 337
  - color
    - harmonies 2, 389
  - Color blend mode 352
    - legacy version 352
  - Color Changer tool 38, 256
  - color channels 654
    - adjusting brightness 189
    - combining 656
    - creating masks from 375
    - mixing 184
    - splitting images into 655
    - splitting in masks 375
  - color depth 71, 629
    - decreasing 633
    - image palettes. *See* image palettes
  - increasing 632
  - setting palette options 640
  - viewing 631
  - viewing for images 631
  - viewing for monitors 631
  - viewing number of image colors 632
  - viewing number of layer colors 632
  - Web requirements for 758
- Color dialog box
    - displaying color values 673
    - displaying colors 673
  - Color Harmonies 391
  - color management 652
    - setting up profiles 653
  - color models 647
    - CMYK 649
    - HSL 648
    - RGB 648
  - color palettes, custom 409
  - Color Picker 389, 391
  - color profiles 652
    - CMYK 654
  - Color Replacer tool 37, 595
    - vs. Flood Fill tool 260
  - color vibrancy, enhancing 202
  - Colored Chalk effect 429

- Colored Edges effect 436
- Colored Foil effect 437
- Colored Pencil effect 430
- Colored Pencil tool 39, 622
  - setting options for 622
- colorizing photos 198
- colors 647
  - adding pixels to selections 309
  - adding to selections 310
  - adjusting balance 182
  - adjusting cast 185
  - adjusting lightness 202
  - adjusting saturation 202
  - calibrating monitor 651
  - calibrating printer 747
  - changing 255
  - choosing 391, 394
  - choosing from desktop 394
  - choosing from dialog boxes 46
  - choosing from HSL values 391
  - choosing from HTML codes 391
  - choosing from images 394
  - choosing from Mixer palette 611
  - choosing from RGB values 391
  - choosing from swatches 409
  - choosing with Color Picker 389
  - correcting 331
  - correcting faded 185
  - defining working spaces 654
  - diffusing 639
  - displaying on monitors 650
  - dithering 639
  - filling image areas with 260
  - foreground, choosing 254
  - GIF file, choosing 765
  - grid, choosing 676, 739, 744
  - guide, choosing 56
  - hiding information 672
  - hiding transparent 647
  - making transparent 646
  - managing with profiles 652
  - marker, choosing 401
  - mask, choosing 370
  - mixing 610
  - organizing layers by 345
  - painting with continuous 597
  - paletted image, choosing 393
  - PNG file, choosing 771
  - printing 650
  - printing as backgrounds 732
  - printing CMYK separations 745
  - reducing 639

- removing from selections 310
  - replacing 258, 639, 644
  - resetting to default settings 202
  - setting modes 673
  - shifting 201
  - sorting in image palettes 644
  - swapping foreground and background 389
  - viewing image information 78
  - viewing layer information 78
  - viewing number of 632
  - viewing transparent 647
  - Web-safe 642
  - workspace, choosing 55
- combining**
- batches of HDR photos 285
  - color channels 656
  - images 332, 517
  - photo content 287
  - photos with Exposure Merge 276
- commands**
- accessing legacy 703
  - adding legacy 703
  - adding to toolbars 663
  - disabling in scripts 717
  - keyboard shortcuts for 52
  - removing from scripts 712, 717
  - removing from toolbars 664
  - repeating 93
  - restricting 711
- community sites 22**
- compressing**
- images 64
  - modes for 759
- connecting**
- Bézier curve segments 587
  - contours 579
  - freehand curves 589
  - line segments 583, 590
  - line segments in preset shapes 561
  - nodes 579, 583
- constraining**
- crop areas 158
  - lines 583
- contact sheets, printing 729, 732**
- context menus 52**
- listing all 52
- continuous color**
- painting with 597
- contours**
- adding 578
  - adding nodes to 568
  - breaking at nodes 580

- closing 578
- deleting 582
- duplicating 581
- editing 579
- joining 579
- moving 580
- offsetting duplicated 581
- reversing 581
- selecting all nodes on 567
- selecting specific nodes on 567
- Contours effect 438**
- contracting**
  - nodes 569
  - selections 309
- contrast, adjusting 186**
  - along with brightness and gamma 195
  - by stretching histograms 194
- converting**
  - files in batches 724
  - photos to black and white 197, 480, 638
  - photos to duotone 200
  - RAW files 146
  - text to curves 545
  - vector objects to paths 577
- cookie cutter 2**
- Copy Special command 87**
- copying 84**
  - active images 49
  - images 87
  - layers to other images 342
  - location information 122
  - merged layers 85
  - resources 695
  - saved images 67
  - selected image areas 305
  - selections or layers 85
  - vector objects 85, 591
- Corel Auto-Preserve folder 683**
- Corel Knowledgebase 22**
- Corel products, updating 7**
- Corel Support Services 7, 22**
- corners**
  - curling 474
  - rounding polygon or star 559
  - setting radii for 556
- correcting**
  - barrel distortion 181
  - color cast 185
  - colors 331
  - exposure with histograms 192
  - faded colors 185
  - fish-eye distortion 182
  - image areas with brushes 252

- images 150
- images cosmetically 233
- lens distortions 180
- light, midtone, and dark areas 175
- photographic perspective 164
- pincushion distortion 182
- scratches 238
- tone 331
- Crayon tool** 39, 621
  - setting options for 622
- creating images** 69
- Creator IDs** 785
  - personalizing 788
- crop marks** 729
  - printing 734
- Crop tool** 35
  - setting preferences for 676
- cropping** 156
  - clearing 160
  - constraining proportions 158
  - defining area interactively 158
  - freely rotating 159
  - images for print 160
  - images to selections 161
  - moving rotation axis 159
  - moving rotation axis to the center 159
  - rotating area by 90 degrees 158
  - rotating area by a specific angle 158
  - setting preferences for 159
  - setting shading 159
  - straightened images 164
  - to create a new image 162
  - to opaque areas 161
  - vs. resizing canvas 271
- crosshairs**
  - using for all tools 672
  - using with sampling regions 175
- cross-processed photos** 489
- Curlicues effect** 449
- curling corners** 474
- cursor preferences**
  - setting for brush tools 672
  - using precise crosshairs 672
- curves**
  - adjusting 570
  - converting text to 545
  - drawing 586
  - modifying 589
  - straightening 570
- Curves dialog box** 189
- cusp nodes** 564

- custom palette 409
- customer support 7, 22
- customizing
  - application settings 657
  - brush settings 600
  - effects 516
  - keyboard shortcuts 666
  - line styles 585
  - menus 662, 678
  - Mixer pages 612
  - palettes 40, 673
  - patterns from selections 319
  - rulers 675
  - toolbars 40, 663, 664
  - workspaces 659
- Cutout effect 421
- cutouts 2, 546
  - shapes 561
  - text 546
- cutting 84
  - layers 85
  - line segments 591
  - objects from background 250
  - selections 85
  - vector objects 85
- cyanotypes 488
- Cylinder–Horizontal effect 466
- Cylinder–Vertical effect 467

## D

- daguerreotypes 488
- dark areas, correcting 175
- Darken blend mode 351
- darkening
  - overexposed photos 172
  - photos automatically 169
  - photos with backlighting 172
- darkening photos
  - with Black slider 170
  - with Lighten/Darken tool 254
- dashes, line 586
- data, retouching layer 254
- database, about 703
- defining
  - CMYK profiles 654
  - color working spaces 654
- defloating selections 306
- deformation maps 528
  - loading 529
  - saving 528
- deinterlacing
  - video capture images 206
- deleting images 94, 128
- density

- brush stroke 596
- depth
  - color. *See* color depth
- descriptive text
  - adding to scripts 713
  - entering for print layout templates 740
- deselecting nodes 567
- despeckling pixels
  - multiple 210
  - single 209
- detaching text from paths 542
- details, adjusting Clarity 188
- dialog boxes
  - choosing colors 46
  - common features of 42
  - deleting sample box buttons 180
  - displaying for scripts 713
  - displaying Help for 18
  - editing numeric values 44
  - randomizing settings in 47
  - resizing 42, 45
  - using color boxes 44
  - using preview windows 44
- Difference blend mode 354
- diffusing colors 639
- digital photos
  - getting 60
  - raw data vs. RAW file format 685
  - removing noise 173
  - viewing information 77
- digital watermarks 785
  - embedding 786
  - personalizing Creator ID 788
  - reading 786
  - setting durability 787
- digital workflow 9
- Dilate effect 461
- Discovery Center 21
- disk
  - loading masks from 381
  - loading selections from 320
  - saving masks to 383
- Displacement Map effect 450
  - using 459
- displacement maps 459
  - adding file locations 692
  - applying 459
  - copying 695
  - deleting 694
  - deleting file locations 693
  - managing 694
  - moving 695
  - renaming 694



- setting file locations 691
- display preferences** 670
- Dissolve blend mode** 353
- distorting**
  - images 270
  - text 550
  - vector objects 571
- Distortion effects** 449
  - Curlicues 449
  - Displacement Map 450
  - Lens Distortion 450
  - Pinch 451
  - Pixelate 452
  - Polar Coordinates 453
  - Punch 454
  - Ripple 454
  - Spiky Halo 455
  - Twirl 456
  - Warp 457
  - Wave 458
  - Wind 459
- distributing**
  - lightness across photos 194
  - vector objects 572
  - vector objects on canvas 575
- dithering colors** 639
- docking**
  - palettes 40
  - preferences for 40
  - toolbars 40
- documentation conventions** 15
- Dodge blend mode** 354
- Dodge tool** 36, 252
- downloading**
  - picture tubes 520
- drawing**
  - Bézier curves 586
  - circles 557
  - curves 586
  - ellipses 557
  - free-form lines 584
  - freehand curves 588
  - lines 582
  - polygons 558
  - preset shapes 560
  - rectangles 555
  - segments, multiple 584
  - segments, single 582
  - shapes 551
  - squares 555
  - stars 558
  - symmetric shapes 558
  - vector objects 551
  - with Art Media tools 607
- Drop Shadow effect** 422

Drop Shadow layer style 367

## Dropbox

uploading Share My Trip  
slideshow 754

## Dropper tool 35

hiding color information 672

dry pigments 614

drying Art Media layers 608

DSLR features 14

duotone, converting to 200

## duplicating

active images 49

contours 581

images 74

layers 342

durability, watermark 787

## E

early color photos 489

## Edge effects 461

Dilate 461

Enhance 462

Enhance More 462

Erode 462

Find All 463

Find Horizontal 463

Find Vertical 464

High Pass 464

Trace Contour 465

Edge Seeker selections 298

## edges

adding borders 263

blending 243

filling with background 164

modifying for selections 317

preserving 209

sharpening 169

smoothing rectangle 556

smoothing square 556

wrapping pixels around 473

Edit workspace 27

## editing

applying captured editing  
130

capturing image editing 130

images. *See* adjusting images

print layouts 742

Python code 717, 718

saved searches 108

scripts 718

vector objects 551, 563

Effect Browser 416

setting thumbnail size 672

## effects

3D 420

applying 413

- applying to raster text 544
- applying to text 544
- applying to vector text 544
- Art Media 427
- Artistic 431
- browsing 419
- choosing from Effect Browser 419
- choosing from Effects menu 417
- choosing from Instant Effects palette 418
- creating 332
- creating user-defined 516
- Edge 461
- Geometric 466
- Illumination 470
- Image 473
- modifying preset 419
- modifying selections with 312
- Photo 476
- Reflection 494
- resetting values 418
- reusing user-defined 517
- saving settings 417
- saving user-defined 517
- Texture 499
- types of. *See name of specific effect*
- Effects layers 361**
- Ellipse tool 38**
- ellipses**
  - drawing 557
  - positioning centerpoints 558
  - setting radii 557
- e-mailing photos 749**
- embedding**
  - digital watermarks 786
  - photos in e-mail 749
- Emboss effect 500**
- Emboss layer style 365**
- Emboss tool 37, 253**
- emptying Clipboard 87**
- Enamel effect 439**
- end caps 586**
- Enhance effect 462**
- Enhance More effect 462**
- enhancing 188, 189**
- environment maps 448**
  - applying 448
- equalizing histograms 194**
- Eraser tool 37, 594**
  - switching to 249, 251
  - using with image maps 779
  - using with image slices 774

## erasing

- background areas 248, 250
- image areas 243, 244, 249, 265
- lines from backgrounds 249
- map areas 781
- pigments 615
- setting levels for 596
- straight lines from images 248
- versus undoing 245

## Erode effect 462

## EV settings for bracketing 276

## Exclusion blend mode 355

## EXIF information

- editing 134
- viewing 77

## expanding

- layer groups 337
- nodes 569

## exporting

- brush tips 605
- GIF files 761
- gradients 403
- JPEG files 767
- PNG files 769

## exposure

- correcting 192

## Exposure Merge 276

## Express Lab

- starting from the main application window 140
- user interface overview 140

## Express Lab mode 139

## extracting, objects from background 250

## Eye Drop mode 235

## eye drops

- applying 235

## F

## face recognition 112

## Facebook 751

- importing friends list 116
- sharing slideshows 754
- syncing check-in points 118
- tagging people 112

## facial blemishes

- removing 234

## facial wrinkles

- removing 236

## fading

- between layers with masks 369
- images with gradients 395

- feathering**
  - selections 242, 314, 316
- features**
  - legacy 703
  - new 1
- Feedback effect 494**
- file extensions**
  - loading all plug-ins 697
- file formats**
  - batch-converting 724
  - choosing 64
  - choosing for print 747
  - excluding 682
  - saving images to last used 671
  - setting associations 690
  - setting preferences 684
  - supported 94
  - Web requirements for 758
- file locations, resource**
  - adding 692
  - deleting 693
  - setting 691
- filenames, displaying for thumbnails 682**
- filenames, printing 732**
- files**
  - compressing 64
  - converting in batches 724
  - displaying recent 678
  - opening from the Manage workspace 63
  - opening recently viewed 63
  - printing images to 733
  - processing in batches 723
  - renaming batch-converted 725
  - renaming in batches 727
  - running scripts on multiple 725
  - running scripts on open 63
  - saving selections to 320
  - stopping batch conversions 725
  - Web requirements for 758
- fill flash**
  - brightening photos with 171
  - darkening photos with 172
- Fill Light/Clarity 188**
- filling**
  - cropped edges 164
  - images 260
  - masks 379
  - properties for 385
  - text 547
- film effects**
  - applying 476, 491
- Film Looks**

- applying 494
- filter effects**
  - applying 491
- filters**
  - applying effect 476
  - Creative 493
  - Film 494
- Find All effect 463**
- Find Horizontal effect 463**
- Find Vertical effect 464**
- finding images 106**
  - by location 118
  - by people 112
  - by tag 111
  - Smart Collections 108
  - using Calendar 111
- Fine Leather effect 500**
- fisheye distortion 181**
  - correcting 182
- fitting**
  - images to screen 51
  - images to windows 51
  - text to paths 540
  - windows to images 51, 83
  - windows to screen 51
- fixing**
  - common problems 150
  - images in one step 168
  - images with Smart Photo Fix 168
- flattening**
  - images 759
  - layers 759
- flaws, removing 240**
- Flickr 751**
  - importing friends list 116
  - tagging people 112
- flipping**
  - images 262
  - layers 262
  - nodes 569
  - selections 262
- floating**
  - palettes permanently 674
  - selections 305
  - toolbars 41
- Flood Fill tool 38**
  - vs. Color Replacer tool 260
- focus**
  - creating with depth of field 211
  - sharpening for images 217
  - sharpening for photo edges 169
  - softening 220
- folders**

- browsing for images 124
- specifying uncataloged 682
- viewing all cataloged 105
- fonts**
  - changing attributes 535
- foreground**
  - choosing color 254
  - swapping with background 389
- formatting**
  - text 535
- frames**
  - picture 514
- free-form lines, drawing** 584
- freehand curves**
  - choosing line style 589
  - connecting 589
  - drawing 588
  - setting joints for 589
  - setting line width 589
  - smoothing 589
- Freehand Selection tool** 35
  - creating selections with 298
- Freehand selections** 298
- fringe, removing** 172
- full-screen previews** 78
- Full-screen viewing** 10
- Fur effect** 501
- G**
- gamma, adjusting**
  - along with brightness and contrast 195
- gaps, line**
  - adding 586
  - deleting 586
  - removing all 586
- Gaussian blurring** 216
- Gaussian noise, adding** 204
- General Info panel**
  - displaying 133
- Geometric effects** 466
  - Circle 466
  - Cylinder–Horizontal 466
  - Cylinder–Vertical 467
  - Pentagon 467
  - Perspective–Horizontal 468
  - Perspective–Vertical 468
  - Skew 469
  - Spherize 470
- GIF files** 759
  - choosing colors from Color dialog box 765
  - choosing colors from images 765
  - interlacing 761

- optimizing 761
  - optimizing with wizard 765
  - saving 761
  - setting preferences for 765
  - setting transparency for 765
- glints, centering** 232
- Glowing Edges effect** 440
- Google+**
- importing friends list 116
  - tagging people 112
- GPS data** 118
- Gradient Editor** 400
- gradients** 395
- adding file locations 692
  - adding markers 401
  - applying current 396
  - changing marker color 401
  - changing marker location 400
  - changing midpoint location 400
  - changing transparency 402
  - choosing 397
  - copying 695
  - creating 399
  - deleting 399, 694
  - deleting file locations 693
  - deleting markers 401
  - editing 400
  - exporting 403
  - filling masks with 379
  - importing 403
  - managing 694
  - moving 695
  - renaming 399, 694
  - saving as swatches 398
  - saving edited 398
  - setting file locations 691
  - using swatches with 409
- graphics**
- adding to layers 331
  - raster. *See* raster graphics
  - vector. *See* vector graphics
- grayscale color depth** 634
- decreasing images to 638
- Grid tool** 774
- grids** 53
- changing color 739, 744
  - choosing color 55, 676
  - displaying 54
  - displaying in print layouts 744
  - setting preferences for print layout 744
  - setting properties 55
  - setting snap influence 55
  - sizing when setting transparency 676
  - snapping print layout images



- to 744
- snapping to 58
- spacing 744
- warping image areas with 527
- grouping
  - layers 347
  - vector objects 576
  - vector objects with Layers palette 576
- guides 53
  - changing color 56
  - deleting 57
  - displaying 54
  - positioning 56
  - setting default properties 56
  - snapping to 58
- H**
- Halftone effect 441
- Hard Light blend mode 354
  - sharpening with 218
- hardness, brush 596
- HDR (high dynamic range) 274
  - Batch Merge 285
  - Exposure Merge 276
  - taking photos for 275
- Help
  - training videos 15
  - Web-based resources 21
- Help system 17
- high dynamic range (HDR), about 274
- High Pass effect 464
- high-frequency sharpening 218
  - applying 218
  - applying with low-frequency sharpening 219
- highlights, adjusting 192
- Histogram palette 31
- histograms 186
  - correcting exposure with 192
  - equalizing 194
  - increasing contrast with 194
- History palette 31, 89
  - customizing 668
  - redoing actions with 92
  - undoing actions with 91
- holes, removing selection 311
- Hot Wax Coating effect 442
- hotspots
  - creating 778
  - creating circular 779
  - creating elliptical 779
  - creating irregular-shaped

- 779
  - creating rectangular 779
  - creating square 779
  - deleting 779
  - modifying 779
  - moving 779

- HSL color model 648**
  - choosing colors from values 391

- HTML codes**
  - specifying colors with 392

- hue 198, 648**
  - adjusting 200
  - mapping 201

- Hue blend mode 351**
  - legacy version 351

- Hue Up/Down tool 37, 253**

## I

- icons**
  - assigning scripts 720
  - assigning to scripts 720
  - removing scripts 721
  - unbinding scripts 721

- Illumination effects 470**
  - Lights 471
  - Sunburst 472

- illustrations 333**

- Image Arithmetic dialog box 517**

- image brightness, preserving during resize 681**

- Image effects 473**

- Offset 473
  - Page Curl 474
  - Seamless Tiling 475

- image information 132**

- advanced 134
  - captions 134
  - color information 78
  - creation date 133
  - in the Edit workspace 76
  - in the Open dialog box 63
  - Info palette 132
  - rating 134

- Image Mapper dialog box 778**

- image palettes 641**

- editing 643
  - hiding transparency 647
  - loading 645
  - loading Web-safe 646
  - resetting 644
  - saving 644
  - setting transparency 646
  - sorting colors 644
  - viewing transparency 647

- image resolution 71, 746**

- changing 226
  - customizing 675
  - effects of resizing on 221
  - setting default 675
- image size 71**
- Image Slicer dialog box 773**
- image windows 47**
- arranging multiple 50
  - cascading 50
  - closing 49
  - fitting images to 51
  - fitting to images 51
  - fitting to screen 51
  - magnifying 670
  - minimizing or maximizing 49
  - moving 48
  - panning 51
  - proofing changes in 46
  - redrawing 680
  - resetting magnification 670
  - resizing 49, 669
  - resizing automatically 670
  - setting preferences for 669
  - tabbed 48
  - tiling 50
- images**
- saving for office programs 68
- image\_slice\_line 774**
- importing**
- brush tips 605
  - friends list from sharing sites 116
  - gradients 403
  - KML files 123
  - legacy picture tubes 524
  - location information 123
  - vector data for WMF files 687
- Info palette 24, 31, 132**
- information, image**
- See image information*
- Infrared Film effect 477**
- applying 481
- Inner Bevel effect 423**
- Inner Glow layer style 366**
- installing applications 4**
- Instant Effects palette 31, 415**
- choosing effects 418
- interlacing 761**
- inverting**
- masks 378
  - selections 313, 323
- IPTC data 64**
- adding 78
  - editing 134
- italic text formatting 536**

## J

### jagged edges

- preventing for selections 316
- preventing in raster conversion 689
- smoothing for Bézier curves 588
- smoothing for freehand curves 589
- smoothing for lines 583
- smoothing for preset shapes 561
- smoothing for rectangles 556
- smoothing for squares 556
- smoothing in text 539

### join styles

- freehand curve 589
- line segment 583
- preset shape 561

### joining

- Bézier curve segments
  - automatically 587
- contours 579
- freehand curves 589
- line segments 583, 590
- line segments in preset shapes 561
- nodes 579, 583

### JPEG files 64, 766

- optimizing 767

- optimizing with wizard 768
- removing artifacts from 207
- saving 767

## K

### Kaleidoscope effect 495

### Kerning text 538

### keyboard shortcuts 52

- accessing menu commands with 52
- adjusting brush sizes with 616
- assigning 667
- customizing 666
- modifying 667
- viewing all 52
- viewing default 666

### keyword tags

- See tags*

### KML files 118

- importing 123

## L

### language, switching 701

### Layer effects 361

### Layer Styles 361

### Layer Styles Visibility toggle 368

- layered images
  - creating images from 75
- layers 326
  - adding text or graphics 331
  - adjusting 359
  - adjustment 330
  - applying mask layers to 375, 376
  - Art Media 330
  - background 328
  - Bevel style 365
  - blending 350
  - choosing source material from 243
  - clearing contents 341
  - collapsing groups 337
  - copying 85
  - copying merged 85
  - copying to other images 342
  - creating 338
  - creating from images 340
  - creating from selections 339
  - creating images from 75
  - cropping to opaque areas 161
  - cutting 85
  - deleting 341
  - displaying settings for 338
  - duplicating 342
  - expanding groups 337
  - flattening 759
  - flipping 263
  - grouping 347
  - inverting visible and hidden 344
  - linking 349
  - linking groups 349
  - mask 330
  - masking 372
  - merging 357, 759
  - mirroring 263
  - moving 345
  - moving on canvas 346
  - organizing by color 345
  - pasting as new 86
  - promoting background 340
  - promoting background layers 340
  - promoting from selections 306
  - protecting transparent areas 356
  - raster 329
  - rearranging 345
  - Reflection 363
  - removing from groups 348
  - renaming 343
  - retouching data 254
  - selecting 336
  - selecting nontransparent areas on all 297
  - selecting nontransparent areas on current 297

- selecting pixels 302
- setting blend ranges 355
- setting opacity 355
- setting PNG preferences for transparency 688
- straightening multiple 164
- straightening single 164
- ungrouping 348
- unlinking 349
- unlinking groups 349
- using Art Media layers 608
- using with illustrations 333
- using with photos 331
- vector 329
- viewing 344
- viewing color information 78
- viewing number of colors 632
- Web requirements for 758
- Layers palette 31, 334**
  - displaying layer settings 338
  - displaying or hiding 336
  - expanding or collapsing layers 337
  - grouping vector objects with 576
  - hiding thumbnails 337
  - modifying 337
  - resizing 338
  - resizing thumbnails 337
  - selecting layers 336
  - selecting vector objects with 555
  - setting preferences 674
- layouts, print**
  - See* print layouts
- leading, text 538**
- learning 15**
- Learning Center palette 18, 31**
  - displaying or hiding 19
  - using 20
- legacy features**
  - accessing 703
- Lens Distortion effect 450**
- lens distortions 181, 450**
  - correcting 180
  - correcting barrel 181
  - correcting fisheye 182
  - correcting pincushion 182
- Levels dialog box 195**
- light areas, correcting 175**
- Lighten blend mode 351**
- Lighten/Darken tool 36, 252**
- lightening photos**
  - See* brightening photos
- lightness 198, 648**
  - adjusting 200

- adjusting for print 747
- changing for all colors 202
- distributing across photos 194
- Lights effect 471**
- limiting shadow changes 254**
- line segments 552**
  - displaying nodes while drawing 583
- line styles**
  - choosing for Bézier curves 588
  - choosing for freehand curves 589
  - choosing for preset shapes 560
  - choosing for rectangles 556
  - choosing for squares 556
  - customizing 585
  - resetting 586
  - undoing changes 586
- line width**
  - choosing for Bézier curves 588
  - choosing for freehand curves 589
  - choosing for preset shapes 560
  - choosing for rectangles 556
  - choosing for squares 556
- lines**
  - adding dashes or gaps 586
  - adjusting segments 590
  - applying through text 536
  - constraining 583
  - creating end caps 586
  - cutting segments 591
  - deleting dashes or gaps 586
  - drawing 582
  - drawing curved 584
  - drawing free-form 584
  - drawing multiple segments 584
  - drawing one segment 582
  - drawing straight 584
  - erasing straight from backgrounds 249
  - erasing straight from images 248
  - formatting for rectangles 556
  - formatting for squares 556
  - joining segments 583, 590
  - joining segments in rectangles 556
  - joining segments in squares 556
  - modifying 589
  - removing all dashes and gaps 586
  - setting segment joints 583
  - smoothing 583
- linking**
  - layer groups 349

- layers 349
- listing**
  - context menus 52
  - open images 50
- Live effects** 361
- loading**
  - deformation maps 529
  - image palettes 645
  - images 60
  - map settings 783
  - masks 380
  - masks from alpha channels 380
  - masks from disk 381
  - Mixer area pages 613
  - plug-ins 697
  - scripts 707
  - selections 319
  - selections from alpha channels 322
  - selections from disk 320
  - slice settings 778
  - Web-safe color palette 646
  - workspaces 661
- Local Tone Mapping** 189
- location information** 118
  - adding manually 122
  - copying and pasting 122
  - creating slideshow 754
  - deleting 124
  - importing 123
  - privacy 120
  - sorting photos 124
- locking**
  - transparent areas of raster layers 356
- log files, saving**
  - for batch conversions 725
  - for scripts 727
- lossless compression** 759
- lossy compression** 759
- low-frequency sharpening**
  - applying with high-frequency sharpening 219
- luminance**
  - adjusting 192
  - masking with 373
- Luminance blend mode** 352
  - legacy version 352
- M**
- Magic Fill 2,** 243
- Magic Wand tool** 35
  - creating selections with 299
- magnifying**
  - image areas 83
  - image windows 669



- images by specified percentages 82
- images to 100% 82
- Magnifying Lens effect** 442
  - applying bump maps with 448
- Makeover tool** 36
  - applying eye drops with 235
  - applying suntans with 235
  - applying the Thinify effect 236
  - removing blemishes with 234
  - whitening teeth with 235
- Manage workspace** 24, 99
  - choosing display mode 102
  - resizing panels 102
  - setting up 100
- map areas** 778
  - creating 780
  - creating rollovers for 782
  - erasing 781
  - moving 781
  - previewing in Web browsers 782
  - removing all 781
  - reshaping 781
  - resizing 781
  - saving 780
  - saving information to Clipboard 782
  - selecting 781
- Map mode** 121
- mapping**
  - hue 201
  - images for Web 778
  - settings for 782
  - settings for, loading 783
  - settings for, saving 782
- Marker tool** 39, 623
  - setting options for 623
- markers**
  - adding 401
  - changing color 401
  - changing location for gradients 400
  - changing transparency 402
  - deleting 401
- marquee, selection** 291
  - hiding or displaying 303
  - moving 304
- mask layers**
  - applying to underlying layers 375, 376
  - creating 372
- mask overlays** 370
  - changing color 370
  - changing opacity 370
  - displaying or hiding 370
  - hiding from image view 373
- masks** 369

- creating 371
- creating from channels 375
- creating from images 373
- creating from selections 374
- creating with luminance 373
- deleting 377
- displaying on images 372, 375, 376
- displaying or hiding 371
- editing 377
- filling 379
- gradients for 379
- inverting 378
- loading 380
- loading from alpha channels 380
- loading from disk 381
- patterns for 379
- rearranging layers 373
- sample 371
- saving 382
- saving to alpha channels 383
- saving to disk 383
- sharing 380, 382
- splitting color channels 375
- textures for 379
- materials 385**
  - applying current to all tools 398
  - applying current to tools 406
  - applying to tools 408
  - changing style 408
  - filling image areas with 260
  - replacing 258
  - swapping foreground and background 389
- Materials palette 31, 385**
  - displaying or hiding 389
  - saving settings for scripts 712
- maximizing image windows 49**
- media, simulating**
  - dry 619, 620, 621, 622
  - wet 617, 623
- Median Filter dialog box 209**
- menu bar 27**
- menus**
  - accessing legacy commands 703
  - accessing with keyboard shortcuts 52
  - animating 662
  - assigning scripts to 720
  - context, using 52
  - customizing 662, 678
  - removing scripts from 721
  - resetting 662
- merged layers, copying 85**
- merging**
  - layers 357, 759
  - nodes 568

- merging photos 273
- Mesh Warp tool 38
- midpoints, gradient 400
- midtones
  - adjusting 192
  - correcting 175
- minimizing image windows 49
- mirroring
  - images 262
  - layers 262
  - nodes 569
  - selections 262
- Mixer areas
  - saving as Mixer pages 613
- Mixer pages
  - clearing 611
  - customizing 612
  - loading 613
  - panning 611
  - saving from Mixer areas 613
- Mixer palette 31, 609
  - using colors 611
- mixing
  - color channels 184
  - colors 610
- moiré patterns, removing 208
- monitors
  - calibrating colors 651
  - displaying colors 650
  - viewing color depth 631
- montages 332
- Mosaic–Antique effect 502
- Mosaic–Glass effect 503
- motion blurring 216
- Move tool 35
  - using with image maps 779
- moving
  - captions 738
  - contour paths 580
  - contours 580
  - glints to pupil centers 232
  - hotspots 779
  - image windows 48
  - layers 345
  - layers on canvas 346
  - map areas 781
  - nodes 567
  - print layout templates 741
  - rectangles and squares 556
  - resources 695
  - selected image areas 304
  - selection marquee 304
  - selections 303
  - slice borders 774
  - slice lines or borders 776
  - text 543

- text along paths 543
- text blocks 550
- toolbar buttons 663
- toolbars or palettes 41
- vector objects 573, 591
- vector text 543

**Multiply blend mode 352**

## **N**

**Navigation palette 31**

**negatives**

- creating 185
- printing 732

**Neon Glow effect 445**

**new features 1**

**new image, create from crop 162**

**newsgroups 22**

**nodes 552, 564**

- adding new start or end 568
- adding on contours 568
- adjusting curves with 570
- adjusting line segments with 590
- breaking contours at 580
- contracting 569
- deleting 570
- deselecting 567

- displaying while drawing line segments 583

- expanding 569

- flipping 569

- joining 579, 583

- merging 568

- mirroring 569

- modifying 564

- moving 567

- rotating 569

- selecting 566

- selecting contour 567

- selecting multiple 567

- selecting on paths 567

- selecting specific contours 567

- skewing 569

- straightening curves between 570

- transforming 569

- types of 564

**noise 202**

- adding 202

- protecting image areas from removal 176

- removing 173, 202

- removing distinct areas 209

- removing quickly 174

- removing while preserving edges 209

- removing while preserving textures 211

- removing with advanced options 175
- non-masked areas, selecting 302
- nontransparent areas, selecting
  - on all layers 297
  - on current layer 297
- Normal blend mode 351
- numeric values 44
  - editing 46
- O**
- Object Extractor 249
- Object Remover tool 36
- objects 552
  - cutting from background 250
  - image, removing 240, 265
  - raster. *See also* raster objects
  - vector 552
  - vector. *See also* vector objects
  - vector. *See* vector objects
- Offset effect 473
- offsetting
  - duplicated contours 581
  - text fitted to paths 542
- Oil Brush tool 38, 617
  - setting options for 617, 625
- one-step fixes 150
  - noise 174
  - photos 168
  - purple fringe 173
- opacity
  - adjusting 243
  - changing for masks 370
  - setting for layers 355
  - setting for paint 596
- opaque areas 161
- opening
  - application 5
  - images 62
  - images from the Navigation palette 63
  - multiple image views 50
  - RAW photos 63
  - recently viewed files 63
  - Script Editor 707
- optimizing
  - GIF files 761
  - images for Web 757
  - JPEG files 767
  - PNG files 769
- Organizer palette 32
  - e-mailing photos from 749
- organizing images 99

- organizing layers 345
- orientation, page
  - switching 689
- Outer Bevel effect 425
- Outer Glow layer style 364
- output, script
  - clearing 709
  - displaying 708
- Overlay blend mode 353
  - sharpening with 218
- Overview palette 32
  - panning images with 83
- P**
- Page Curl effect 474
- page orientation
  - switching 689
- Paint Brush tool 36, 594
- Paint Shop Pro 9 703
- painting
  - built-up strokes 597
  - creating selections when 301
  - opacity for 596
  - wet look 597
  - with Art Media tools 607
  - with continuous color 597
  - with dry pigments 614
    - with picture tubes 521
    - with wet look 597
    - with wet pigments 614
- paintings 332
- Palette Knife tool 39, 626
  - setting options for 626
- paletted images
  - choosing colors for 393
- palettes 27
  - color depth. *See* image palettes
  - customizing 40
  - displaying 32, 658
  - displaying all 41
  - displaying automatically 674
  - docking 40
  - docking, preferences for 40
  - hiding 32, 658
  - making undockable 674
  - moving 41
  - resizing 32, 41
  - rolling up 41
  - setting preferences for 673
  - setting view options for 702
  - types of 30
  - using 30
- Pan tool 35
  - using with image maps 779
- panning 81

- image maps 779
- image previews 45
- image windows 51
- images 83
- images while using other tools 83
- images with Overview palette 83
- Mixer pages 611
- panoramic photos 332**
- paper quality**
  - choosing for print 747
- parameters 44**
  - randomizing 47
- Pastel tool 38, 620**
  - setting options for 620
- pasting 84**
  - as new images 86
  - as new layers 86
  - as selections 86
  - images into other applications 87
  - transparent selections 679
- paths 552**
  - attaching text to 541
  - converting vector objects to 577
  - detaching text from 542
  - editing 579
  - fitting text to 540
  - moving contours in 580
  - moving text 543
  - positioning text 542
  - reversing 581
  - selecting nodes 567
- Pattern effect 497**
- patterns 404**
  - adding file locations 692
  - applying current 405
  - choosing 405
  - copying 695
  - creating from selections 319
  - deleting 694
  - deleting file locations 693
  - filling masks with 379
  - filling text with 547
  - managing 694
  - moving 695
  - renaming 694
  - saving as swatches 406
  - saving images as 406
  - setting file locations 691
  - using active images as 406
  - using selections as 406
  - using swatches 409
  - vs. textures 404
- pausing script recording 708**
- PCD file format preferences 687**

- Pen tool 38
- Pencil effect 430
- Pentagon effect 467
- people 112
- personalizing Creator IDs 788
- perspective
  - changing asymmetrically 270
  - changing asymmetrically for text 550
  - changing symmetrically 269
  - changing symmetrically for text 550
  - changing symmetrically for vector objects 571
  - correcting 164
  - correcting in image layers 166
- Perspective Correction tool 36
- Perspective–Horizontal effect 468
- Perspective–Vertical effect 468
- Photo Blend 287
- Photo effects 476
  - Black and White Film 477
  - film and filter effects 476
  - Infrared Film 477
  - Selective Focus 478
  - Sepia Toning 478
  - Time Machine 476
  - Vignette 479
- photo objects 2
- photographic negatives
  - creating 185
  - printing 732
- Picasa 751
- Pick tool 35
  - correcting perspective with 166
  - selecting vector objects with 554
- picture frames 514
- Picture Tube tool 38, 519, 594
  - setting preferences for 521
- picture tubes 519
  - adding file locations 692
  - copying 695
  - creating 522
  - deleting 694
  - deleting file locations 693
  - getting 520
  - importing from previous versions 524
  - managing 694
  - moving 695
  - painting with 521
  - renaming 694
  - setting file locations 691



## **pigments**

- blending 615, 626, 627
- erasing 615
- painting with dry 614
- painting with wet 614
- smearing 615, 626, 627

## **Pinch effect 451**

## **pincushion distortion 181**

- correcting 182

## **pivot point, text rotation 550**

## **Pixel Resize resampling method 223**

## **Pixelate effect 452**

## **pixels**

- adding to selections 309
- blurring with intensity 215
- converting to black and white 197
- moving vector objects by 573
- restoring to background 249, 251
- restoring to image 248
- selecting 302
- wrapping around canvas 473

## **places 118**

## **platinum prints 489**

## **playback modes, script 715, 717**

## **plug-ins**

- adding locations 697
- enabling 697
- loading all 697
- opening files in 697
- setting preferences for 696

## **PNG files 64, 768**

- choosing colors from Color dialog box 771
- choosing colors from images 771
- optimizing 769
- optimizing with wizard 771
- saving 769
- setting preferences for 688, 771

## **Point to Point selections 299**

## **Polar Coordinates effect 453**

## **Polished Stone effect 504**

## **Polygon tool 779**

## **polygons**

- drawing 558
- rounding inner corners 559
- rounding outer corners 559
- setting radii 559

## **positioning**

- captions 738
- contours 580
- glints in pupil centers 232

- guides 56
  - image windows 48
  - images in print layouts 736, 745
  - layers on canvas 346
  - map areas 781
  - nodes 567
  - print layout templates 741
  - rectangles and squares 556
  - selected image areas 304
  - selection feathering 315
  - selection marquee 304
  - slice lines or borders 776
  - text 543
  - text blocks 550
  - text on paths 542, 543
  - toolbar buttons 663
  - toolbars or palettes 41
  - vector objects 573, 591
  - vector text 543
- Posterize effect 446**
- PostScript files**
- anti-aliasing 689
  - prompting when opening 689
  - setting preferences 688
  - switching page orientation 689
  - using white background 689
- pre-filtering plug-in files 697**
- preparing images for print 746**
- preserve image brightness setting 681**
- preserving**
- edges while removing noise 209
  - images 331
  - textures while removing noise 211
- Preset Shape tool 38**
- preset shapes**
- drawing 560
  - formatting line style 560
  - formatting line width 560
  - joining line segments 561
  - maintaining aspect ratio 561
  - positioning centerpoints 561
  - smoothing 561
- presets 721**
- choosing 722
  - creating for brushes 602
  - deleting 723
  - editing 723
  - restoring to default settings 722
  - saving settings as 722
  - saving shapes as 563
- pressure support**
- for puck-type pointing devices 680

- Preview images 24
- preview windows 44
  - zooming 45
  - zooming to sampling regions 176
- previewing
  - fixes to chromatic aberrations 180
  - image maps in Web browsers 782
  - images 45, 63
  - images for Web 772
  - images in the Manage workspace 125
  - images on full screen 78
- print layout templates
  - creating 745
  - deleting 742
  - editing 739
  - editing cells in 740
  - entering descriptive text 740
  - moving 741
  - printing images with 733
  - reverting to print layouts 741
  - saving print layouts as 745
  - saving with images 741
- print layouts 735, 739
  - adding captions 737
  - adding images 735
  - changing grid color 739
  - closing 736
  - displaying grid 744
  - editing 742
  - positioning images 736, 745
  - printing 735
  - resizing images 743
  - reverting templates to 741
  - rotating images 737, 745
  - saving 742
  - saving as templates 745
  - setting grid preferences 744
  - setting workspace options 738
  - snapping images to grid 744
  - spacing 739
  - undoing or redoing changes 738
  - using borders 743
  - zooming 737
- Print Size group box 226
- printer resolution 746
- printing
  - active images 731
  - CMYK color separations 745
  - color backgrounds around images 732
  - colors 650
  - contact sheets 729, 732
  - crop marks 734
  - cropped images 160

- filenames 732
  - Help topics 17
  - images 729
    - images to file 733
    - images with templates 733
    - images, preparing for 746
    - negatives 732
    - print layouts 735
    - professional outputs 729
    - registration marks 729, 734
    - setup options for 736
  - privacy when sharing photos 120
  - processing files in batches 723
  - professional output
    - printing for 734
  - profiles, color management 652
    - setting up 653
  - projects 69
    - starting 69
  - promoting
    - background layers 340
    - selections to layers 306
  - proofing
    - changes 46
  - protecting
    - image areas from noise
      - corrections 176
      - transparency of raster layers 356
  - puck-type pointing devices
    - disabling pressure support 680
  - Punch effect 454
  - purple fringe, removing 172
  - Push tool 37, 253
  - Python 705
  - Python programming language
    - editing code 717, 718
- ## Q
- Quick Review 10
  - Quick Review mode
    - using 135
  - quitting 5
- ## R
- radial blurring 216
  - radii
    - setting for circles and ellipses 557
  - radii, setting
    - for corners 556

- for polygons and stars 559
- Rainbow tab**
  - displaying colors in 673
- random noise, adding 204
- randomizing
  - parameters 47
  - values to create effects 516
- raster graphics 69
  - vs. vector graphics 69
- raster layers
  - creating from selections 339
  - promoting background layers from 340
  - protecting transparent areas 356
- raster objects 552
- raster selections
  - creating from vector objects 302
- raster text 532
  - applying effects 544
- rate, Airbrush tool 597
- rating images 133, 134
- RAW files 64, 685
  - setting preferences 689
- RAW photos 143
  - adjusting settings 145
  - capturing edits 146
  - converting to another format 146
  - editing 146
  - opening 63
  - supported file formats 143
  - using the Camera RAW Lab 144
- reading digital watermarks 786
- rearranging
  - layers 345
  - mask layers 373
- recording scripts 708, 709
- recovering anti-aliasing 317
- Rectangle tool 38
  - using with image maps 779
- rectangles
  - choosing line style 556
  - choosing line width 556
  - drawing 555
  - joining segments 556
  - moving 556
  - setting corner radii 556
  - sizing 556
  - smoothing edges 556
- Red Eye tool 36
- red-eye, removing 230, 232

- with advanced options 230
- with Red Eye tool 230
- redoing**
  - actions 88
  - actions with History palette 91
  - changes to print layouts 738
  - color mixing 610
  - preferences for 668
- redrawing image windows** 680
- reducing colors** 639
- Reflection effects** 494
  - Feedback 494
  - Kaleidoscope 495
  - Pattern 497
  - Rotating Mirror 498
- registration** 6
- registration marks**
  - printing 729, 734
- renaming**
  - alpha channels 322
  - batch-converted files 725
  - files 128
  - files in batches 727
  - gradients 399
  - layers 343
  - resources 694
  - saved searches 109
  - swatches 411
- renderings, artistic** 616
- repeating commands** 93
- replacing**
  - colors 258, 639, 644
  - materials 258
  - selections 297
- resampling images** 222
- reshaping**
  - map areas 781
  - selections 233
- resizing**
  - canvas 271
  - captions 738
  - dialog boxes 45
  - grids when setting transparency 676
  - image windows 49, 669
  - images 221, 267
  - images in print layouts 743
  - Layers palette 338
  - map areas 781
  - palettes 32
  - pixel dimensions 227
  - sample boxes 180
  - swatch thumbnails 412
  - text 549
  - thumbnails in Layers palette 337

- toolbars or palettes 41
- vector objects 571
- Resource Manager dialog box** 694
- resources**
  - adding file locations 692
  - categorizing 696
  - copying 695
  - deleting 694
  - deleting file locations 693
  - learning 15
  - managing 694
  - moving 695
  - renaming 694
  - setting file locations 691
- restoring**
  - erased pixels to background 249, 251
  - erased pixels to images 248
  - images 229
- restoring your database** 703
- restricted scripts** 710
  - unavailable commands for 711
- Retouch Brush tools** 595
- retouching**
  - image areas with brushes 252
  - images 229
  - layer data 254
- reusing effects** 417
- reversing**
  - contours 581
  - foreground and background 389
  - images 262
  - layers 262
  - paths 581
  - selections 262
  - tool behavior 254
- reverting**
  - templates to print layouts 741
  - to saved images 91
- RGB color model** 648
  - choosing colors from values 391
- Ripple effect** 454
- rolling up**
  - palettes 41
  - toolbars 41
- rollovers** 783
  - creating 783
  - creating for map areas 782
  - creating for slice cells 777
- rotating**
  - brush tips 596
  - captions 738

- image thumbnails 127
- images 154, 269
- images 90 degrees 155
- images in print layouts 737, 745
- images interactively 156
- images to specified angles 155
- nodes 569
- selections 303
- selections for animal eyes 233
- text 550
- vector objects 571

**Rotating Mirror effect 498**

**Rough Leather effect 505**

**rounding polygons and stars**

- outer corners 559

**rulers 53**

- customizing 675
- displaying 54
- displaying in black and white 675
- displaying in color 675
- setting measurement unit for 675
- setting properties for 54

**running multiple scripts 707**

**running scripts 707, 713**

- interactively 707
- listed 714

- multiple 714
- on all open images 715
- silently 707
- unlisted 714

## S

**Safety palette 642**

**Salt and Pepper filter 210**

**sample boxes**

- removing chromatic aberrations with 178

**sampling points**

- using with Smart Photo Fix 169

**sampling regions**

- removing digital camera noise with 175
- using crosshairs with 175

**Sandstone effect 506**

**saturation 198, 648**

- adjusting 200
- changing for colors 202
- increasing or decreasing 169, 202

**Saturation blend mode 351**

- legacy version 351

**Saturation Up/Down tool 37, 253**



## saving

- custom line styles 585
- deformation maps 528
- edited gradients 398
- effect settings 417
- GIF files 761
- gradients as swatches 398
- image copies 67
- image palettes 644
- images 64, 68
- images as patterns 406
- images as textures 408
- images for office applications 68
- images for Web 757
- images with last file format 671
- JPEG files 767
- log files for batch conversion 725
- log files for scripts 727
- map area information to Clipboard 782
- map areas 780
- map settings 782
- masks 382
- masks to alpha channels 383
- masks to disk 383
- Mixer areas as pages 613
- original unedited files 683
- patterns as swatches 406
- PNG files 769

- preferences for automatic 699
- print layout templates with images 741
- print layouts 742
- print layouts as templates 745
- scripts 708, 709
- selections 319
- selections to alpha channels 321
- selections to file 320
- settings as presets 722
- shapes as presets 563
- slice settings 778
- slice settings to Clipboard 777
- user-defined effects 517
- workspaces 660

## scaling

- images 267
- options for 268
- photos with Smart Carver 265

## scratch disk 672

## Scratch Remover tool 36

## scratches, removing 238

- automatically 205

## screen

- fitting images and windows to 51

- Screen blend mode 353
- screen captures 79
  - specifying methods for 79
  - specifying sources of 80
  - taking 80
- Script Editor 707
- Script Output palette 32
  - clearing 709
  - displaying 708
- Script toolbar 707
  - displaying 708
- scripts 705
  - accessing 708
  - adding descriptive information 713
  - adding file locations 692
  - assigning icons 720
  - assigning to menus or toolbars 720
  - canceling recording 708
  - choosing 707
  - choosing trusted 707
  - clearing output 709
  - copying 695
  - deleting 694
  - deleting file locations 693
  - disabling actions or commands 717
  - displaying dialog boxes 713
  - displaying output 708
  - editing 716, 718
  - editing Python code 717, 718
  - loading 707
  - managing 694
  - moving 695
  - pausing recording 708
  - presets for. *See* presets
  - recording 708, 709
  - removing actions or commands 717
  - removing from menus or toolbars 721
  - removing undone commands from 712
  - renaming 694
  - restricted vs. trusted 710
  - running 707, 713
  - running as files open 63
  - running during batch conversions 725
  - running in Silent Mode 727
  - running interactively 707
  - running listed 714
  - running multiple 707, 714
  - running on all open images 715
  - running on multiple files 725
  - running silently 707, 727
  - running unlisted 714
  - saving 708, 709
  - saving log files 727

- setting file locations 691
  - setting playback mode for 715, 717
  - setting text editor 718
  - stepping through 719
  - stopping 708, 716, 726
  - stopping at errors 727
  - troubleshooting 719
  - unbinding from icons 721
  - undoing 716
  - using with Materials palette 712
- Sculpture effect 507**
- Seamless Tiling effect 475**
- searching for images 106**
- advanced search 106
  - quick search 106
- selecting**
- contour nodes 567
  - layers 336
  - map areas 781
  - multiple nodes 567
  - multiple thumbnails 127
  - nodes 566
  - nodes on paths 567
  - non-masked areas 302
  - nontransparent areas on all layers 297
  - nontransparent areas on current layer 297
  - pixels 302
  - slice cells 774
  - specific contour nodes 567
  - swatches 410
  - vector objects 554
  - vector objects with Layers palette 555
  - vector objects with Pick tool 554
- Selection tool 35**
- creating selections with 296
- selections 291**
- adding borders 318
  - adding colors 310
  - adding pixels 309
  - adding to 308
  - adjusting feather amount 315
  - adjusting feather position 315
  - adjusting feathering 315
  - adjusting feathering position 315
  - applying anti-aliasing 316
  - clearing 313
  - clipping 303, 323
  - contracting 309
  - copying 85
  - copying and moving image areas 305
  - creating 292
  - creating brush tips from 603

- creating masks from 374
- creating patterns 319
- creating raster from vector objects 302
- creating raster layers from 339
- creating with Freehand Selection tool 298
- creating with Magic Wand tool 299
- creating with painting tools 301
- creating with Selection tool 296
- creating with Text tool 301
- cropping to 161
- cutting 85
- defloating 306
- deleting 233
- displaying marquee 303
- erasing image areas 243
- expanding 309
- feathering 242, 314, 316
- flipping 263
- floating 305
- hiding marquee 303
- inverting 313, 323
- loading 319
- loading from alpha channels 322
- loading from disk 320
- mirroring 263
- modifying 307
  - modifying edges 317
  - modifying with tools and effects 312
  - moving 303
  - moving image areas 304
  - moving marquee 304
  - pasting as 86
  - promoting to layers 306
  - recovering anti-aliased 317
  - removing colors 310
  - removing holes and specks 311
  - removing scratches automatically 205
  - replacing 297
  - reshaping 233
  - rotating 303
  - saving 319
  - saving to alpha channels 321
  - saving to file 320
  - sizing 297
  - smoothing boundaries 317
  - softening focus 220
  - subtracting from 308
  - unfeathering 316
  - using as patterns 406

**Selective Focus 478, 482**

**sending**

- photos by e-mail 749

**sensor blooming 177**

- Sepia Toning effect 478
  - applying 482
- shading, preferences for 676
- shadows
  - adjusting 192
  - limiting changes to 254
- shape cutouts 561
- Shape Cutter 2, 562
- shape libraries 563
  - creating 564
  - deleting 564
- shapes
  - applying anti-aliasing based on 316
  - drawing 551
  - drawing preset 560
  - drawing symmetric 558
  - editing 551
  - editing with Tool Options palette 563
  - filling with images 561
  - saving as presets 563
- shaping
  - brush tips 595
  - vector objects 571
- Share My Trip 754
- sharing
  - brush tips 605
  - masks 380, 382
  - photos 749
- sharing sites
  - uploading photos 751
- Sharpen tool 37, 253
- sharpening
  - edges 169
  - images 217
  - images minimally 219
  - images moderately 219
  - images with high frequency 218
  - images with low and high frequency 219
  - video capture images 206
- shearing
  - images 270
  - text 550
  - vector objects 571
- shifting colors 201
- shortcut keys
  - See* keyboard shortcuts
- simulating media
  - dry 619, 620, 621, 622
  - wet 617, 623
- sizing
  - brush tips 595
  - images 71

- rectangles 556
  - selections 297
  - squares 556
  - transparency grids 676
  - vector objects 571
- Skew effect** 469
- skewing nodes** 569
- Skin Smoothing feature**
  - smoothing skin tone with 237
- slice borders**
  - deleting 776
  - moving 776
- slice cells** 773
  - creating 775
  - creating rollovers for 777
  - omitting 776
  - sizing evenly 776
  - spacing evenly 776
- slice lines**
  - deleting 776
  - moving 776
- Slice tool** 774
- slicing**
  - cells evenly 776
  - images 773
  - images into cells 775
  - settings for 777
  - settings for, loading 778
  - settings for, saving 778
  - settings for, saving to Clipboard 777
- slideshow** 754
- Smart Carver** 265
- Smart Collections searches** 108
  - deleting 109
  - editing 108
  - renaming 109
  - running 108
- Smart Edge** 3, 254, 597
- Smart Edge selections** 299
- Smart Photo Fix** 150
  - fine-tuning basic corrections with 168
  - setting advanced options for 169
- Smart Selection Brush** 35, 295
- Smart Size resampling method** 223
- Smear tool** 39, 627
  - setting options for 627
- smearing pigments** 615, 626, 627
- smooth nodes** 564
- smoothing**

- Bézier curves 588
- curved polylines in WMF files 687
- edges of rectangles and squares 556
- freehand curves 589
- lines 583
- preset shapes 561
- selection boundaries 317
- skin tone 237
- text 539
- Smudge tool 37, 253**
- snapping 53**
  - to grids 58
  - to grids, setting influence for 55
  - to guides 58
  - to print layout grid 744
- Soft Light blend mode 354**
  - sharpening with 218
- Soft Plastic effect 508**
- Soften tool 37, 253**
- softening**
  - focus 220
  - images 220
  - images minimally 221
  - images moderately 221
- Solarize effect 446**
- sorting image thumbnails 126**
- sorting photos**
  - by location 124
  - by people 113
- sorting swatches 412**
- source materials**
  - applying tonal ranges to 243
  - choosing from layers 243
- spacing**
  - grids 744
  - print layouts 739
  - text characters 539
  - text horizontally 538
  - text vertically 538
- special effects**
  - See effects*
- specks, removing**
  - from selections 311
  - multipixel 210
  - single-pixel 209
- Spherize effect 470**
- Spiky Halo effect 455**
- splash screen, hiding 680**
- splitting images**
  - into color channels 655
- spotlights, applying 471**
- spraying images 519**

## squares

- choosing line style 556
- choosing line width 556
- drawing 555
- joining segments 556
- moving 556
- setting corner radii 556
- sizing 556
- smoothing edges 556

## stars

- drawing 558
- rounding inner corners 559
- rounding outer corners 559
- setting radii 559

## starting

- Script Editor 707

## starting the application 5

## status bar 27

## steps

- customizing for undo and redo 668
- running scripts through individual 719
- setting for brushes 596, 600

## stitching photos 332

## stopping

- batch conversions 725
- scripts 708, 716, 726
- scripts at errors 727

## straight lines

- erasing 249

## straight lines, erasing

- from images 248

## Straighten tool 35

## straightening

- angles 164
- cropping images after 164
- curves between nodes 570
- images 162
- multiple layers 164
- single layers 164

## Straw Wall effect 509

## stretching histograms 194

## strikethrough text formatting 536

## strokes

- applying multiple 597
- building up paint 597
- setting brush density 596
- setting brush thickness 596
- setting paint steps 596, 600
- setting properties 387
- undoing multiple 599
- undoing recent 599
- width of. *See* line width

## styles 385

- join. *See* join styles



- line. *See* line styles
- subsampling
  - chroma 766
- Sunburst effect 472
- suntan, applying 235
- support, customer 7, 22
- supported file formats 94
- suppressing warnings
  - all 677
  - specific 677
- surface textures, applying 499
- swap disk 672
- swapping foreground and background 389
- swatches 409
  - choosing colors 391
  - creating 410
  - deleting 411
  - displaying 411
  - editing 411
  - renaming 411
  - resizing thumbnails 412
  - saving gradients as 398
  - saving patterns as 406
  - selecting 410
  - sorting 412
- Switch application language 701
- Symmetric Shape tool 38
- symmetric shapes, drawing 558
- symmetrical nodes 564
- T**
- tabbed image windows 47
  - enabling or disabling 48
- tablet settings 600
- tags 109
  - assigning to images 110
  - creating 109
  - deleting from catalog 110
  - find nontagged images 111
  - find tagged images 111
  - removing from images 110
  - tagging locations 118
  - tagging people 112
- tanning effect 235
- tasks, automating 705
- Technical Support 22
- teeth, whitening 235
- templates
  - print layout. *See* print layout templates
- text 531

- adding to layers 331
  - aligning 537
  - anti-aliasing 539
  - applying effects 544
  - attaching to paths 541
  - changing center of rotation 550
  - changing leading 538
  - changing perspective
    - asymmetrically 550
  - changing perspective symmetrically 550
  - converting to curves 545
  - creating 533
  - deleting 534
  - detaching from paths 542
  - distorting 550
  - entering for print layout templates 740
  - filled with image 546
  - filling 546
  - filling with patterns 547
  - fitting to paths 540
  - formatting 535
  - kerning 538
  - moving 543
  - moving along paths 543
  - moving blocks 550
  - offsetting from paths 542
  - positioning on paths 542
  - raster. *See* raster text
  - resizing 549
  - rotating 550
  - setting direction 537
  - shearing 550
  - smoothing 539
  - spacing characters 539
  - spacing horizontally 538
  - spacing vertically 538
  - tracking 539
  - transforming 549
  - vector 531
  - vector. *See* vector text
  - warping 542
- text boxes 737**
  - text captions**
    - creating for print layouts 737
  - Text Cutter 2, 547**
  - text editors, script 718**
    - changing 718
    - using 717, 718
  - text selections 294, 532**
    - creating 301
  - Text tool 38**
    - creating selections 301
  - Texture effect 510**
  - Texture effects 499**
    - Blinds 499
    - Emboss 500
    - Fine Leather 500

- Fur 501
- Mosaic–Antique 502
- Mosaic–Glass 503
- Polished Stone 504
- Rough Leather 505
- Sandstone 506
- Sculpture 507
- Soft Plastic 508
- Straw Wall 509
- Texture 510
- Tiles 512
- Weave 513
- textures 407**
  - applying current 407
  - applying with effects 499
  - choosing 407
  - filling masks with 379
  - preserving while removing noise 211
  - saving images as 408
  - using swatches 409
  - vs. patterns 404
- thickness, brush stroke 596**
- Thinify effect 236**
- threshold**
  - converting photos with 197
- thumbnails 124**
  - browsing for folders 104
  - displaying filenames for 682
  - displaying in preview area 63
  - hiding in Layers palette 337
  - rotating 127
  - setting size in Effects Browser 672
  - setting size in Layers palette 337
  - sorting 126
  - viewing for folders 104
  - zooming in and out 125
- Tiles effect 512**
- tiling**
  - image windows 50
  - images 475
- tilt-shift 478, 482**
- Time Machine effect 476**
  - choosing settings for 490
  - creating vintage style photos 487
- tolerance**
  - automatic vs. manual 247
  - setting to background color 679
- tones**
  - adjusting balance 183
  - applying ranges to source materials 243
  - correcting 331
  - smoothing skin 237

## **Tool Options palette 32, 595**

editing shapes with 563

## **toolbars 32**

adding commands to 663

assigning scripts to 720

customizing 40, 663, 664

deleting custom 665

displaying 658

displaying all 41

docking 40

floating 41

hiding 658

moving 41

moving buttons on 663

removing commands from  
664

removing scripts from 721

resetting 664

resizing 41

rolling up 41

setting docking preferences  
for 40

setting view options for 702

## **tools**

accessing legacy 703

adding legacy 703

Airbrush 594

applying current materials to  
398

applying materials to 406,  
408

Background Eraser 594

modifying selections with  
312

panning images while using  
83

reversing behavior of 254

types of 34

using precise cursor for 672

## **Tools toolbar**

using tools 34

## **ToolTips**

displaying color values 673

displaying color values, 16-bit  
673

## **tooltips**

for toolbars 32

for tools 34

## **Topography effect 447**

## **Trace Contour effect 465**

## **tracking, text 539**

## **transforming**

images 267

nodes 569

options for 268

text 549

## **transparency**

changing for gradient  
markers 402

hiding from image view 373

- protecting in raster layers 356
- setting for GIF files 765
- setting for image palettes 646
- setting PNG preferences for 688
- setting preferences for 676
- setting tolerance when pasting 679
- viewing or hiding color 647

**trays 136**

- adding 136, 137
- removing 137
- removing photos from 137
- renaming 136
- saving tray content to a folder 138

**tripod, for bracketing 276**

**troubleshooting**

- Color Replacer tool 258
- common problems 150
- pasted images 85
- scripts 719

**trusted scripts 710**

- choosing 707

**tutorials 15**

**Twirl effect 456**

## U

**unbinding scripts 721**

**underlining text 536**

**undoing**

- actions 88
- actions with History palette 91
- brush strokes 599
- changes to print layouts 738
- color mixing 610
- line style changes 586
- preferences for 92, 668
- scripts 716
- vs. erasing 245

**ungrouping**

- layers 348
- vector objects 576

**uniform noise, adding 204**

**uninstalling applications 4**

**units, setting 675**

**unlinking**

- layer groups 349
- layers 349

**unlocking**

- transparent areas of raster layers 356

**updating Corel products 7, 22**

uploading photos to sharing sites 751

User guide 18

## V

vector graphics 69

vs. raster graphics 69

vector layers

collapsing 337

creating from vector objects 340

expanding 337

vector objects

adding contours to 578

aligning 572

aligning to canvas 574

arranging 572

changing perspective  
symmetrically 571

converting to paths 577

copying 85, 591

creating layers from 340

creating raster selections  
from 302

cutting 85

distorting 571

distributing 572

distributing on canvas 575

drawing 551

editing 551, 563

editing contours and paths 579

grouping and ungrouping 576

grouping with Layers palette 576

modifying properties for 563

moving 573, 591

moving by pixels 573

removing from groups 577

saving as presets 563

selecting 554

selecting with Pick tool 554

shearing 571

sizing, shaping, and rotating 571

vector text

applying effects to 544

identifying 536

moving 543

Vibrancy 142

vibrancy of color, enhancing 202

video capture images

sharpening 206

video tutorials 21

viewing

color depth information 631

image areas 51

image information 76

- images 47, 76
- images as they will print or display 373
- layers 344
- location information 119
- preferences for 669, 702
- Python code 717

**Vignette 479, 484**

## **W**

warnings

- setting preferences for 677
- suppressing 677

**Warp Brush tool 38, 525, 594**

**Warp effect 457**

warping

- image areas 525
- image areas with grids 527
- images 459, 525
- images with deformation maps 528
- text 542

**Watercolor Brush tool 39, 624**

watermarks

- adding visible 789

watermarks, digital

- See digital watermarks

**Wave effect 458**

**Weave effect 513**

## **Web**

- creating 3D images for 420
- creating image rollovers for 783
- creating images for 757
- downloading picture tubes from 520
- flattening images for 759
- mapping images for 778
- optimizing GIF files for 759
- optimizing images for 757
- optimizing JPEG files for 766
- optimizing PNG files for 768
- previewing images for 772
- saving images for 757
- slicing images for 773
- tiling images for 475

## **Web browsers 772**

- adding 698
- changing 698
- deleting 699
- previewing image maps 782
- previewing images in 772
- selecting 698
- setting preferences for 698

## **Web-based resources**

- accessing 22

## **Web-safe color palette 642**

- loading 646

Weighted Average resampling method 223

wet pigments 614

wetting Art Media layers 608

width, line

*See* line width

Wind effect 459

windows

arranging 50

cascading 50

fitting images to 83

image. *See* image windows

preview. *See* preview windows

WMF files

importing vector data 687

setting preferences 686

smoothing curved polylines 687

workflow 9

workspaces 23, 24

adding file locations 692

Adjust 26

copying 695

customizing 659

deleting 661, 694

deleting current images 94

deleting file locations 693

Edit 27

loading 661

Manage 24

managing 694

moving 695

renaming 694

saving 660

setting file locations 691

setting print layout options 738

switching between 29

## X

X colors

decreasing images to 638

XMP files 3, 147

## Z

Zoom tool 35

determining rescaling quality for 672

zooming 81

image previews 45

image slices 774

image thumbnails 125

image windows 669

images 82

print layouts 737

sampling regions 176



## Legal Notice

Corel® PaintShop Pro® X7 User Guide

Copyright 2014 Corel Corporation. All rights reserved.

Corel, the Corel logo, Corel DESIGNER, CorelDRAW, Corel Ventura, Digital Studio, PaintShop Pro, Painter, Roxio, Roxio Creator, Toast, VideoStudio, WinDVD, WinZip, and WordPerfect are trademarks or registered trademarks of Corel Corporation and/or its subsidiaries in Canada, the U.S., and/or other countries. Other product, font, and company names and logos may be trademarks or registered trademarks of their respective companies.

INFORMATION PROVIDED HEREIN BY COREL IS PROVIDED "AS IS" BASIS, WITHOUT WARRANTIES OR CONDITIONS, EXPRESS OR IMPLIED, INCLUDING, BUT NOT LIMITED TO, WARRANTIES OF MERCHANTABILITY, FITNESS FOR A PARTICULAR PURPOSE, TITLE AND NON-INFRINGEMENT, OR THOSE ARISING BY LAW, STATUTE, USAGE OF TRADE, COURSE OF DEALING OR OTHERWISE. THE ENTIRE RISK AS TO THE RESULTS OF THE INFORMATION PROVIDED OR ITS USE IS ASSUMED BY YOU. COREL SHALL HAVE NO LIABILITY TO YOU OR ANY OTHER PERSON OR ENTITY FOR ANY INDIRECT, INCIDENTAL, SPECIAL, OR CONSEQUENTIAL DAMAGES WHATSOEVER, INCLUDING, BUT NOT LIMITED TO, LOSS OF REVENUE OR PROFIT, LOST OR DAMAGED DATA OR OTHER COMMERCIAL OR ECONOMIC LOSS, EVEN IF COREL HAS BEEN ADVISED OF THE POSSIBILITY OF SUCH DAMAGES OR THEY ARE FORESEEABLE. COREL IS ALSO NOT LIABLE FOR ANY CLAIMS MADE BY ANY THIRD PARTY COREL'S MAXIMUM AGGREGATE LIABILITY TO YOU SHALL NOT EXCEED THE COSTS PAID BY YOU TO PURCHASE THE MATERIALS. SOME STATES/COUNTRIES DO NOT ALLOW EXCLUSIONS OR LIMITATIONS OF LIABILITY FOR CONSEQUENTIAL OR INCIDENTAL DAMAGES, SO THE ABOVE LIMITATIONS MAY NOT APPLY TO YOU.