

USERS MANUAL

DTH-3002R

Operating Instructions

Table of Contents

1. Unpacking and Checking Equipment

2. Operation Instructions

3. FCC Information

4. FCC Label Information

1. Unpacking and Checking Equipment

Carefully unpack the equipment and its accessories.

- 1). Remote controller
- 2). Base communication module
- 3). Main controller
- 4). kinds of Harness Assembly
- 5). Shock sensor

2. Operation Instructions

2-1. ARMING

The car alarm system checks the intrusion into the car in the arm mode (shock & door open) and pages it the remote controller, and then, it alerts for 45 seconds with siren and light flashing. After alarm, it returns to arm mode.

2-1-1. Pressing the "LOCK" button : Press "LOCK" button shortly, and the Car locks the door and goes into arm mode with audible chirp and visual light flashing. The LED of communication module will be turned on for 5 seconds (ARM delay mode) and then start flashing (ARM mode). The remote controller shows green LED flashing and sounds one short beep. If you press the "LOCK" button under "NO CHIRP MODE", the car acts the same way above, but without chirp.

2-1-2. Automatic passive arming (When the car is set to passive arming) : When the key is pulled out of key box and all doors are closed, the system will arm automatically after 30 seconds. When the car is armed, it acts like above procedures.

Note 1: Passive arming is selectable feature that can be turned ON or OFF by your alarm dealer / installer. Please check the installation guide.

2-1-3. Special functions when entering into arming : When the door is opened and the "LOCK" button is pressed, the car alerts 4 chirps & 4 light flashing.

When the shock sensor is triggering and the "LOCK" button is pressed, the car alerts 3 chirps & 3 light flashing. The car does not alert this status even though it is in arm mode, but , if the door is closed and opened again or if the shock sensor is muted and triggered again, the car sends alarm signal.

2-2. DISARMING

2-2-1. Pressing the button "UNLOCK" shortly disarms the car.

When the car is disarmed, it unlocks the door with two audible chirps and visual light flashing. The remote controller shows green LED flashing and sounds short beeps two times. If you press the "UNLOCK" button under

“NO CHIRP MODE”, the car acts the same way above, but without chirp.

2-2-2. The car memorizes the status of intrusion (door open)in the arm mode and alerts it when the car is disarmed. The car alerts 4 times light flashing and 4 times chirps. The remote controller shows 4 times of green LED and long beeps. The car alerts 3 chirps and 3 light flashing for the triggering of shock sensor during arm mode.

2-3. CAR FIND

When the button “AUX” is pressed shortly, the remote car shows audible beep and visual lighting. The remote controller shows flashing of green LED and sounds short beep four times.

2-4. PANIC (FOR YOUR PERSONAL SAFETY)

When the button “LOCK” or “UNLOCK” is pressed more than 2 seconds, the car will start alarming and flashing for 45 seconds. The panic can be removed by pressing any button and it is helpful for your personal safety.

2-5. TRUNK OPEN

Pressing the button “ASTERISK” for more than 2 seconds can open the trunk of the car. At that time, the remote controller flashes green LED 5 times and sounds short beep 5 times.

2-6. VALET MODE

Valet mode is used to prevent from alarm system arming or triggering.

The alarm should be put into valet mode when the vehicle is being serviced.

Press the button "AUX" more than 2 seconds during the car key is in the position of "ACC" in the key box, then VALET mode is activated.

At the VALET mode, the LED on the base communication module turns ON continuously

and the remote controller turns on green LED and sounds one dual beep. And also the car alerts audible chirp with visual light flashing. Now the car is in VALET mode. Only “LOCK” “UNLOCK” & “AUX” can be activated.

Even though the “LOCK” is activated, the car does not enter into ARMING during VALET mode.

As the VALET mode is toggle function, the car can be return to the DISARM mode when the button “AUX” is pressed once again at the same condition.

When the VALET mode is removed and returns to the DISARM mode, the car alerts audible chirp with visual light flashing.

And the remote controller shows the green LED flashing and 2 times dual beeps.

2-7. PROGRAMMABLE FUNCTIONS

There are 4 programmable functions for the operation of the caralarm system.

These functions can be activated or de-activated by remote controller.
All of these functions can be programmed when the key is located on “ACC” state in the key box.

All of them are toggle functions and the default setting is “ON”.

When these functions are activated, you can hear “BEEP_HI_LO” once.

When these are de-activated, you can hear “BEEP_HI_LO” twice.

2-8. CHIRP / NO CHIRP

When the button “LOCK” is pressed twice shortly (double click) during the car key is in “ACC” position in the key box, the CHIRP sound will be activated or de-activated with the green LED and “BEEP_HI_LO”. The siren in the mode of alarm and panic cannot be removed even though the “CHIRP” is de-activated.

2-9. ADJUSTMENT OF LOCK TIME

When the button “ UNLOCK” is pressed twice shortly, this function can be changed. The default is 3 seconds and the other is 0.8 seconds. As this function is set properly at the time of installation, you need not use this function.

2-10. IGNITION LOCK

When the button “ASTERISK” is pressed twice shortly, this function can be changed. The car locks the door automatically during driving when it is activated, but unlocks the door during driving when it is de-activated.

2-11. ON / OFF OF SENSOR

When you press the button “AUX” twice shortly, you can toggle this function. When the sensor is activated, the car can be triggered by the sensor and alarms the triggering of shock at the arm mode. But the car ignores the triggering of sensor when de-activated.

2-12. PAGING FROM CAR

The paging from the car to the remote controller is unique feature of the 2-way car alarm system.

The user can recognize the intruding into the car even though he/she is far away from it.

When the car is in arm state and triggered by shock sensor or door open, it alerts the status with light flashing and siren. And then, it sends the signal to the remote controller to alert this status to the user.

Now the user can recognize the triggering by the remote controller shows 15 times of green, red LED and “CRICKET” sound. The siren and light can be

removed by pressing any button of remote controller.

2-13. COMMUNICATION ERROR

Sometimes you can see 3 times red LED flashing and dual beeps when you press any button of the remote controller.

This means that the remote controller has communication error.

The communication error can be happened following reasons.

2-13-1. The car is in out of range.

2-13-2. You pressed wrong button for an operation.

2-13-3. There maybe exist a RF interference, which can cause communication error.

2-13-4. Some part of car alarm system has problem itself.

2-13-5. Your remote controller battery would be worn out.

2-14. REPLACEMENT OF CAR BATTERY

When you replace the car battery after installation of car alarm system, the car will treats it as an intruding into the car. So, the car alerts with light flashing and siren for 45 seconds. And, the remote controller shows 15 times of LED flashing with "CRICKET" sounds.

After the alarm, the car returns to the arming.

2-15. REPLACEMENT OF BATTERY IN REMOTE

When the remote controller battery is worn out, the remote controller shows alert message with 2 times of red LED and quadruple beep.

You should replace the battery when you hear this alert.

The car alarm system may operate improperly when you use it without replacing battery.

2-16. SECOND CAR

The remote controller has a special function.

This toggle function offers you can control your 2nd car by same remote controller.

You can select your car by pressing the button "LOCK" & "ASTERISK" simultaneously for more than 2 seconds.

You can hear one long beep or 2 long beeps by pressing the buttons.

One long beep means that the remote controller will control your current (primary) car and two long beeps mean that the remote controller is set for your 2nd car.

All the functions of remote controller for the second car are exactly same.

But you should know that you cannot control your both cars at the same time.

2-17. DESCRIPTION OF HARNESS ASSY

1). RED : RED wire consists with the 15 amp fuse.

This wire would be connected to the vehicle's positive battery terminal or a constant positive +12V power supply.

- 2). BROWN : BROWN wire would be connected with the (+) wire of siren.
And black wire of siren should be connected to ground.
For corrosion resistance, the black wire of siren would be connected inside the vehicle under the dash board.
- 3). WHITE : WHITE wire is positive output from on-board relay for light flashing.
This white wire can be connected to the vehicle's parking light wire at the headlight switch.
Also this wire can be connected directly to any parking light fixture.
- 4). RED/WHITE (WHITE STRIP ON RED) : RED/WHITE wire is connected to the external relay (or relay in the vehicle) for trunk open.
- 5). GRAY : GRAY wire is connected to the dome light (-).
- 6). BLACK : BLACK wire is connected to the battery's negative terminal or to the good chassis ground of the vehicle.
- 7). BLUE/WHITE (WHITE STRIP ON BLUE): BLUE/WHITE wire is connected to the (-) UNLOCK or (+) LOCK output.
- 8). GREEN/WHITE (WHITE STRIP ON GREEN): GREEN/WHITE wire is connected to the (-) LOCK or (+) UNLOCK output.
- 9). ORANGE: ORANGE wire is a negative (-) 500mA output when the alarm system is in the armed mode (ground when armed).
This output can be used with a pre-wired socket for starter kill.
(Relay not included)
- 10).GREEN: GREEN wire is a negative(-) input for door-pin trigger.
The best place to find the door trigger is either at the pin switch or at the dome light.
- 11). VIOLET: VIOLET wire is a positive(+) input for door-pin trigger.
- 12). YELLOW: YELLOW wire is connected to the "ACC" of key box.
- 13). PIN CONNECTOR
Shock sensor is connected to the 3pin connector located in the main controller.
The connector pin description is +12V OUTPUT / TRIGGER INPUT / GND
(from left to right of the connector).
- 14). 8PIN CONNECTOR
The base communication module is connected to the 8pin connector.
- 15). DIP SWITCH
The DIP switch is located on the upper side of main controller.
If the switches are located downward, it is ON state.
Upward means OFF. The right switch is for passive arm.
If the right switch in ON, this means passive arm is activated.
The passive arm is deactivated when it is turned off (located upward).

The left switch is for DOOR LOCK when passive arming.

If this DOOR LOCK switch is ON during passive arming is activated, the car door is locked.

The car door will be UNLOCK state when the left switch is turned off (located upward) even though passive arming is activated.

2-18. PROGRAMMING (CODE RUNNING)

This car alarm system needs programming (code running) when the above installation is finished.

Please follow below procedures.

- 1). Supply the power into the car alarm system through RED & BLACK wire.

Then, the system is in alarm mode.

- 2). Put the key into the key box and turn "ACC " ON and OFF more than 5 times.

Then, the system will be in Valet mode.

- 3). Press the switch on the base communication module for 2-3 seconds. Then, the system will sounds 5 chirps and goes into CODE RUNNING mode.

- 4). Press any button of 2-way remote controller. This will finish first code running.

You should use 2-way remote controller for the first code running.

- 5). Press any button of extra remote controller if you have or press any button of the first remote controller if you do not have extra remote controller.

The second code running is finished now. And the system is in Valet mode.

- 6). Disable the Valet mode. For example, press button "AUX" for more than 2 seconds during the key located "ACC" in the key box.

The system disables the Valet mode and goes to the disarm mode.

All of code running can be done through the procedures.

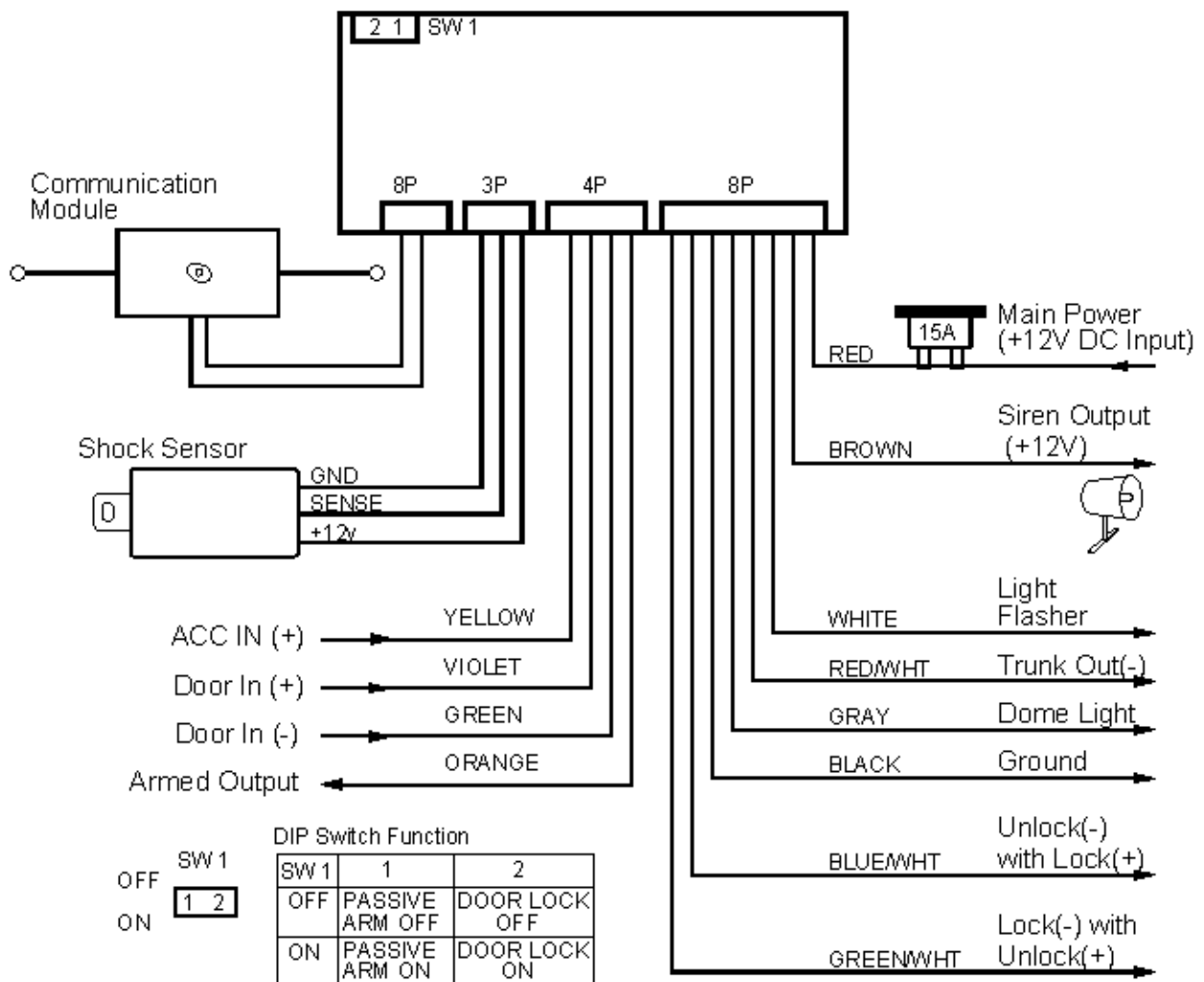

3. FCC Information

Caution : Any changes or modifications in construction of this device which are not expressly approved by the party responsible for compliance could void the user's authority to operate the equipment.

4. FCC Label Information

This device complies with part 15 of the FCC Rules.

Operation is subject to the following two conditions:

(1) This device may not cause harmful interference, and

(2) this device must accept any interference received,
including interference that may cause undesired operation.

DRAKE SYSTEMS

ACE TECHNO 804, YANGPYUNG, YOUNGDEUNGPO , SEOUL 150-103, KOREA

Tel : 82-2-2634-4700 Fax : 82-2-2634-4800

Printed in Korea