

# User Manual Radio Modules

---

**deRFarm7-15A02 / 15C02**

**deRFarm7-25A00 / 25C00**

**deRFarm7-25A02 / 25C02**



**Document Version V1.1**  
**2011-12-22**



## Table of contents

1. Overview .....	5
2. Application.....	5
3. Features .....	6
4. Technical data .....	8
5. Mechanical data .....	10
5.1. Radio module (pluggable).....	10
5.2. Footprint receptacles .....	10
5.3. Radio module (solderable).....	11
5.4. Footprint pads .....	11
5.5. PCB design .....	12
6. Soldering profile of deRFarm7 .....	13
7. Pin assignment.....	14
7.1. External Pins .....	17
7.2. Internal Connections.....	21
8. Programming.....	22
8.1. Required hardware.....	22
8.2. Programming example .....	23
8.3. JTAG interface .....	29
9. Debugging and tracing .....	29
10. RF components .....	30
10.1. deRFarm7-15A02 / 15C02.....	30
10.2. deRFarm7-25A00 / 25C00.....	30
10.3. deRFarm7-25A02 / 25C02.....	31
11. Radio certification .....	32
11.1. United States (FCC) .....	32
11.2. European Union (ETSI) .....	33
11.3. Approved antennas .....	34
12. Ordering information.....	35
13. Revision notes.....	37



## Document history

Date	Version	Description
2011-02-10	1.0	Initial version
2011-12-22	1.1	Addition of PCB design Addition of transceiver signal description Update certification section

## Mailing list

Firm	Division / Name
DE	APA

## Author / Check / Release

	Firm	Division / Name
Author	DE	Dev. / APA
Check		
release		



## Abbreviations

Abbreviation	Description
ADC	Analog to <b>D</b> igital <b>C</b> onverter
BOD	<b>B</b> rownout- <b>D</b> etection
CE	<b>C</b> onsumer <b>E</b> lectronics
DAC	<b>D</b> igital to <b>A</b> nalog <b>C</b> onverter
DBGU	<b>D</b> ebug <b>U</b> nit
ETH	<b>E</b> thernet, family of frame-based computer networking technologies for local area networks (LAN).
EMAC	<b>E</b> thernet <b>M</b> edia <b>A</b> ccess <b>C</b> ontroller
ETSI	<b>E</b> uropean <b>T</b> elecommunications <b>S</b> tandards <b>I</b> nstitute
FCC	<b>F</b> ederal <b>C</b> ommunications <b>C</b> ommission
GPIO	<b>G</b> enerals <b>P</b> urpose <b>I</b> nput <b>O</b> utput
ISM	<b>I</b> ndustrial, <b>S</b> cientific and <b>M</b> edical frequency band
JTAG	<b>J</b> oint <b>T</b> est <b>A</b> ction <b>G</b> roup
ISP	<b>I</b> n- <b>S</b> ystem- <b>P</b> rogramming
MAC	<b>M</b> edium ( <b>M</b> edia) <b>A</b> ccess <b>C</b> ontrol
MCU, $\mu$ C	<b>M</b> icrocontroller <b>U</b> nit
PCB	<b>P</b> rinted <b>C</b> ircuit <b>B</b> oard
PCBA	<b>P</b> rinted <b>C</b> ircuit <b>B</b> oard <b>A</b> ssembled
PWM	<b>P</b> ulse <b>W</b> idth <b>M</b> odulation
RF	<b>R</b> adio <b>F</b> requency
RMI	<b>R</b> educed <b>M</b> edia <b>I</b> ndependent <b>I</b> nterface
SPI	<b>S</b> erial <b>P</b> eripheral <b>I</b> nterface
TWI	<b>T</b> wo- <b>W</b> ire <b>S</b> erial <b>I</b> nterface
U[S]ART	<b>U</b> niversal [ <b>S</b> ynchronous/] <b>A</b> synchronous <b>R</b> eceiver <b>T</b> ransmitter
USB	<b>U</b> niversal <b>S</b> erial <b>B</b> us



## 1. Overview

The compact designed radio modules contains a powerful ARM7 microcontroller with 512 kBytes High-Speed Flash, On-chip USB 2.0 Full Speed Transceiver, Ethernet MAC 10/100 base-T in RMI-Mode and an onboard transceiver for 2.4 GHz or 868/915 MHz.

The 46 pin interface gives access to most hardware functions of the microcontroller.

A long radio transmission range can be achieved by using the coaxial jack (U.FL) version with an external antenna attached. In the Sub-GHz band several hundred meters (100 m = 330 feet) can be reached without problems. The 2.4 GHz version is able to cover up to 200 m (650 feet) with a ceramic chip antenna. All versions have a 128-bit AES encryption unit installed.

The 512 kB Flash and 128 kB RAM of the deRFarm7 modules provide enough resources to be used for any tasks within a wireless sensor network.

## 2. Application

The main applications for the deRFarm7 radio modules are:

- 2.4GHz IEEE 802.15.4
- 868MHz / 915MHz IEEE 802.15.4
- ZigBee<sup>®</sup> Pro
- ZigBee<sup>®</sup> RF4CE
- ZigBee<sup>®</sup> IP
- 6LoWPAN
- Wireless Sensor Networks (WSN)
- industrial and home controlling and monitoring
- Gateway applications between IEEE 802.15.4 and other networks, e.g. Ethernet



## 3. Features

The Sub-GHz radio modules deRFarm7-15A00 / 15C00 offer the following features:

- pluggable: 2 male connectors, 23 pins per row, 1.27mm pitch
- solderable: 23 pads per row, 1.27mm pitch
- RF shielding
- usable signals: power supply, peripheral, programming, debugging, tracing, ADC, GPIO, USB, Ethernet MAC
- application interfaces: 1 x UART, 1 x TWI, 1x USB, 1 x Ethernet-MAC
- Debug/Programming interfaces: 1 x SPI, 1 x JTAG
- Onboard chip-antenna and transceiver for 868/900 MHz
- Certification: FCC pending
- Compliant: CE, ETSI

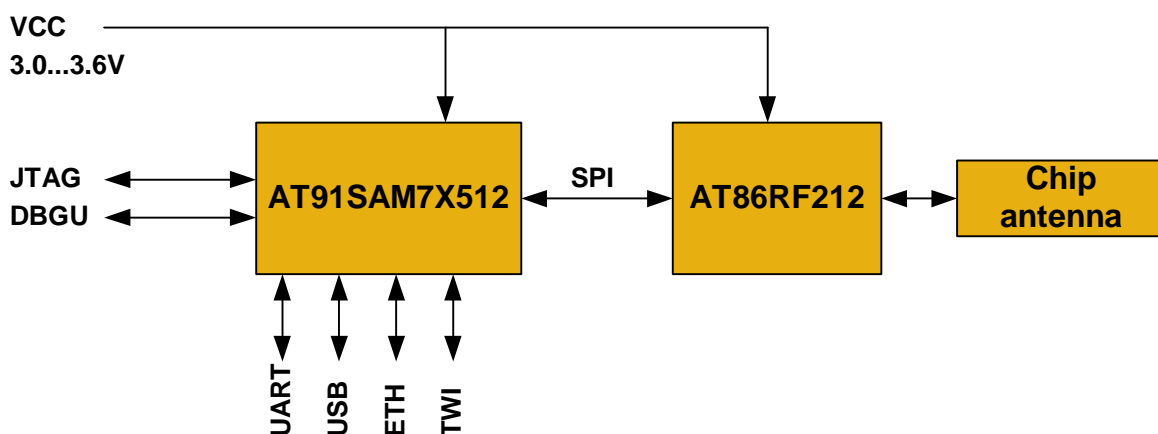

Figure 1: block diagram deRFarm7-15A00 / 15C00

The radio modules deRFarm7-15A02 / 15C02 offer the same features like the deRFarm7-15A00 / 15C00 except the onboard Sub-GHz chip antenna is replaced by an U.FL coaxial receptacle for connecting an external antenna.

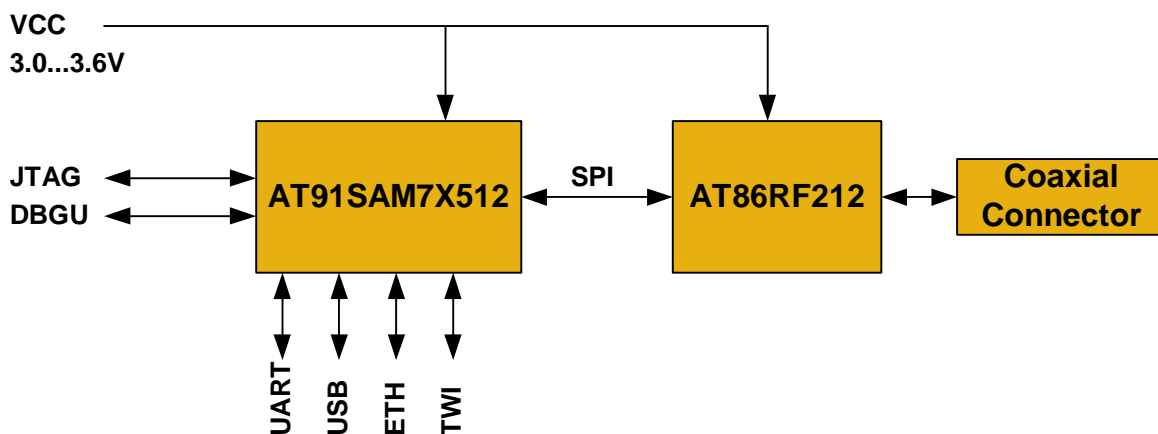

Figure 2: block diagram deRFarm7-15A02 / 15C02



The 2.4 GHz radio modules deRFarm7-25A00 / 25C00 offer the following features:

- compact size: 30 x 22.7 mm (for 25A00) and 30 x 20.4 mm (for 25C00)
- pluggable: 2 male connectors, 23 pins per row, 1.27mm pitch
- solderable: 23 pads per row, 1.27mm pitch
- RF shielding
- usable signals: power supply, peripheral, programming, debugging, tracing, ADC, GPIO, USB, Ethernet MAC
- application interfaces: 1 x UART, 1 x TWI, 1x USB, 1 x Eth-MAC
- Debug/Programming interfaces: 1 x SPI, 1 x JTAG
- Onboard chip-antenna and transceiver for 2.4 GHz
- Certification: FCC pending
- Compliant: CE, ETSI

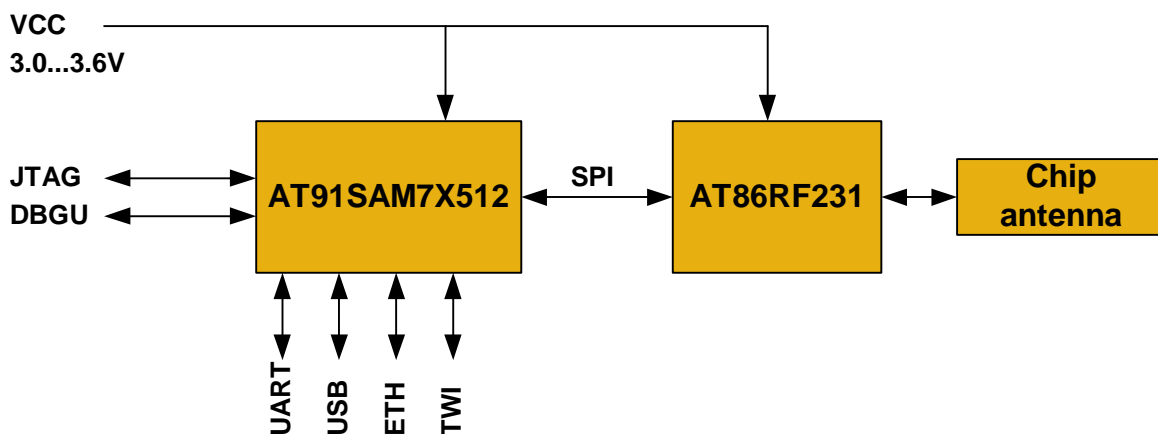

Figure 3: block diagram deRFarm7-25A00 / 25C00

The radio modules deRFarm7-25A02 / 25C02 offer the same features like the deRFarm7-25A00 / 25C00 except the onboard 2.4 GHz chip antenna is replaced by an U.FL coaxial receptacle for connecting an external antenna.

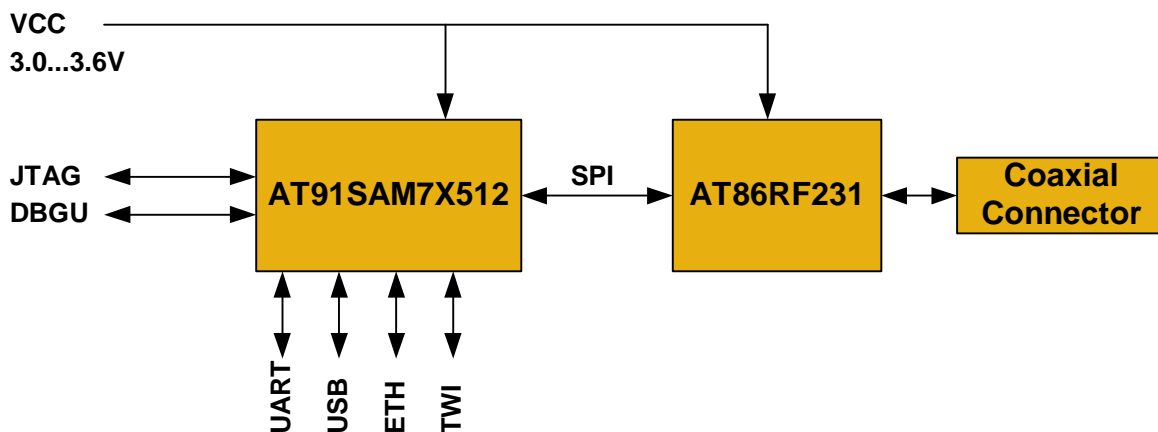

Figure 4: block diagram deRFarm7-25A02 / 25C02



## 4. Technical data

**Table 1: Mechanical data**

Mechanical	
<i>Radio modules</i>	
Size (L x W x H)	30 x 22.7 x 8.2 mm <sup>1</sup> (for deRFarm7-15A02 / 25A00 / 25A02) 30 x 20.4 x 4.3 mm (for deRFarm7-15C02 / 25C00 / 25C02)
<i>Connectors (only for pluggable variants)</i>	
number of headers	2
pins per header	23
pitch	1.27 mm
pin length	3.05 mm
pin diameter	0.51 mm
Insulator (L x W x H)	29.2 x 2.5 x 2.5 mm
<i>Pins / Pads (pluggable and solderable variants)</i>	
pitch	1.27 mm

<sup>1</sup> unplugged radio module

**Table 2: Temperature range**

Temperature range					
		Min	Typ	Max	Unit
Working range	T_work	-40		+85	°C

**Table 3: Electrical data**

Electrical (Vcc = 3.0VDC)					
<i>deRFarm7-15A02 / 15C02</i>					
	Parameter	Min	Typ	Max	Unit
Supply Voltage	VCC	3.0	3.3	3.6	VDC
Current consumption	I_TXon (TX_PWR = +10 dBm)		52		mA
	I_TXon (TX_PWR = +5 dBm)		46		mA
	I_TXon (TX_PWR = 0 dBm)		43		mA
	I_RXon		36		mA
	I_Idle (Txoff, MCK = 12MHz)		21		mA





	I_Idle (Txoff, MCK = 48MHz)		38		mA
	I_Sleep (depends on Sleep Mode)		250		µA
<i>deRFarm7-25A00 / 25A02 / 25C00 / 25C02</i>					
	<i>Parameter</i>	<i>Min</i>	<i>Typ</i>	<i>Max</i>	<i>Unit</i>
Supply Voltage	VCC	3.0	3.3	3.6	VDC
Current consumption	I_TXon (TX_PWR = +3 dBm)		38		mA
	I_TXon (TX_PWR = +1 dBm)		37		mA
	I_TXon (TX_PWR = -17 dBm)		32		mA
	I_RXon		36		mA
	I_Idle (Txoff, MCK = 12MHz)		21		mA
	I_Idle (Txoff, MCK = 48MHz)		38		mA
	I_Sleep (depends on Sleep Mode)		250		µA

**Table 4: Radio transmission data**

<b>Radio (Vcc = 3.3VDC)</b>					
<i>deRFarm7-15A02 / 15C02</i>					
	<i>Parameter</i>	<i>Value</i>			<i>Unit</i>
Frequency range	Channel 0 (EU)	868.3			MHz
Frequency range	Channel 1...10 (US)	906...924			MHz
	<i>Parameter</i>	<i>Min</i>	<i>Typ</i>	<i>Max</i>	<i>Unit</i>
Transmitting power conducted	Channel 0; 20kBit/sec TX_PWR = +5dBm		5.0		dBm
Transmitting power conducted	Channel 1...10; 40kBit/sec TX_PWR = +10dBm		8.5		dBm
<i>deRFarm7-25A00 / 25A02 / 25C00 / 25C02</i>					
	<i>Parameter</i>	<i>Value</i>			<i>Unit</i>
Frequency range	Channel 11...26 (EU)	2405...2480			MHz
	<i>Parameter</i>	<i>Min</i>	<i>Typ</i>	<i>Max</i>	<i>Unit</i>
Transmitting power conducted	Channel 11...26; 250kBit/sec TX_PWR = +3dBm		3.0		dBm



## 5. Mechanical data

### 5.1. Radio module (pluggable)

Used connectors: SAMTEC "TMS-123-02-L-S"

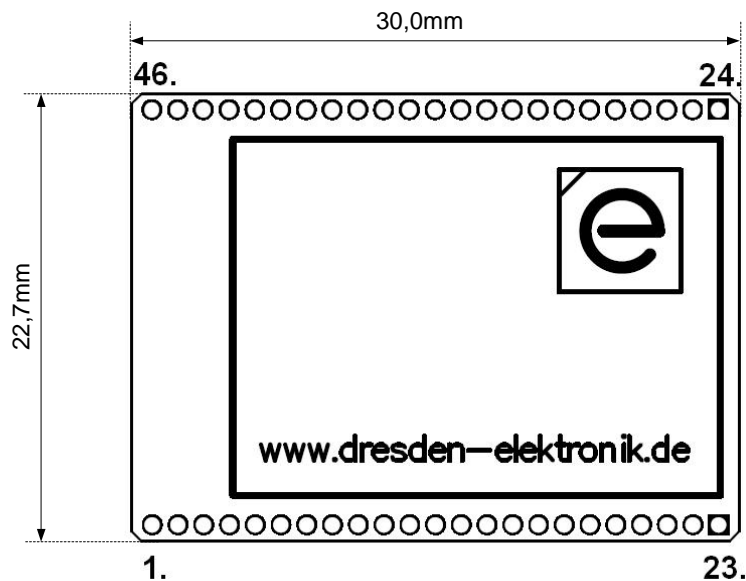

Figure 5: Size deRFarm7-15A02 / 25A00 / 25A02

### 5.2. Footprint receptacles

Used receptacles: SAMTEC "SLM-123-01-L-S"

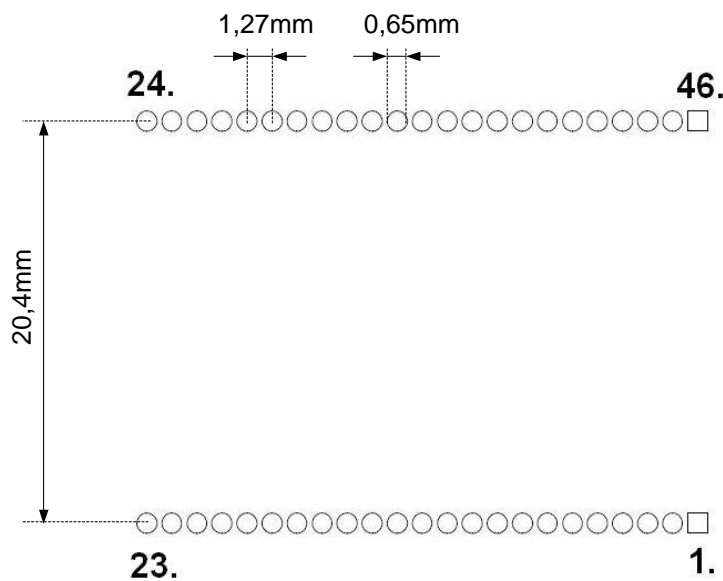

Figure 6: Footprint receptacles 1.27mm pitch

### 5.3. Radio module (solderable)

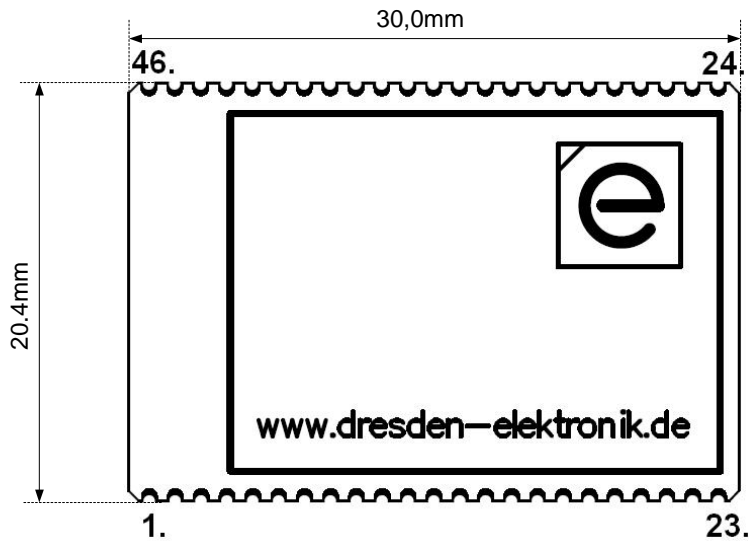

Figure 7: Size deRFarm7-15C02 / 25C00 / 25C02

### 5.4. Footprint pads

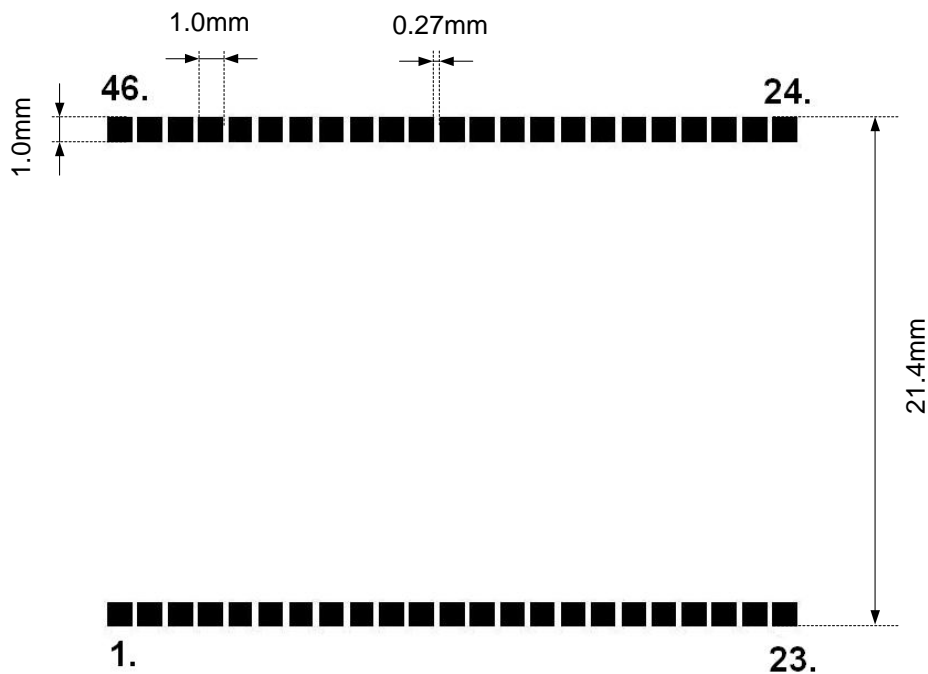

Figure 8: Footprint for deRFarm7-15C02 / 25C00 / 25C02



## 5.5. PCB design

The PCB design of the radio module base board and placement affects the radio characteristic. The radio module should be placed at the edge or side of a base board. The chip antenna should be directed to PCB side.



Do not place ground areas below the radio module and near the chip-antenna.

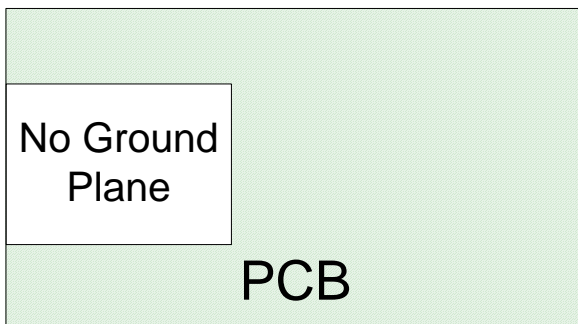

If the base board with the radio module will be placed into a metal case, it is necessary to use the radio module variant with coaxial connector and an external antenna.



## 6. Soldering profile of deRFarm7

Table gives the soldering profile for the radio modules.

**Table 5: Soldering Profile**

Profile Feature	Values
Average-Ramp-up Rate (217°C to Peak)	3°C/sec max.
Preheat Temperature 175°C ±25°C	120 sec. max
Temperature Maintained Above 217°C	60 sec.
Time within 5°C of Actual Peak Temperature	20 sec. to 40 sec.
Peak Temperature Range	260°
Ramp-down Rate	6°C/sec max.
Time 25°C to Peak Temperature	8 min. max.

Figure 9 shows a recorded soldering profile for a radio module. The blue colored line illustrates a temperature sensor placed next to the soldering-contacts of the radio module. The pink line shows the set temperatures depending on the zone within the reflow soldering machine.

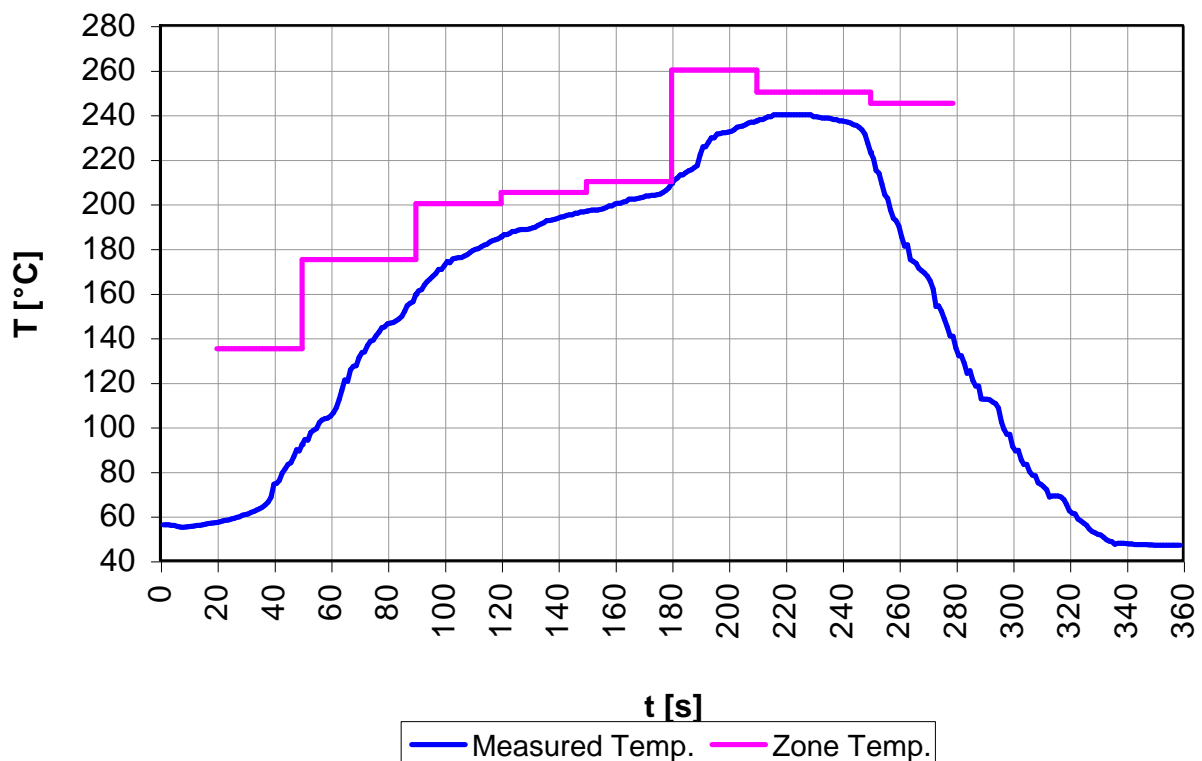

**Figure 9: Recorded soldering profile**

A solder process without supply of nitrogen causes a discoloration of the metal RF-shielding.



## 7. Pin assignment

Both pin headers respectively pin contacts provide the most important signals to the customer: power supply, peripheral, programming, debugging, tracing, analog measurement and free programmable ports. All provided signals except VCC, GND, RSTN, JTAGSEL, TDI, TDO, TCK, TMS, USBDM, USBDP and ADVREF are free programmable port pins (GPIO).

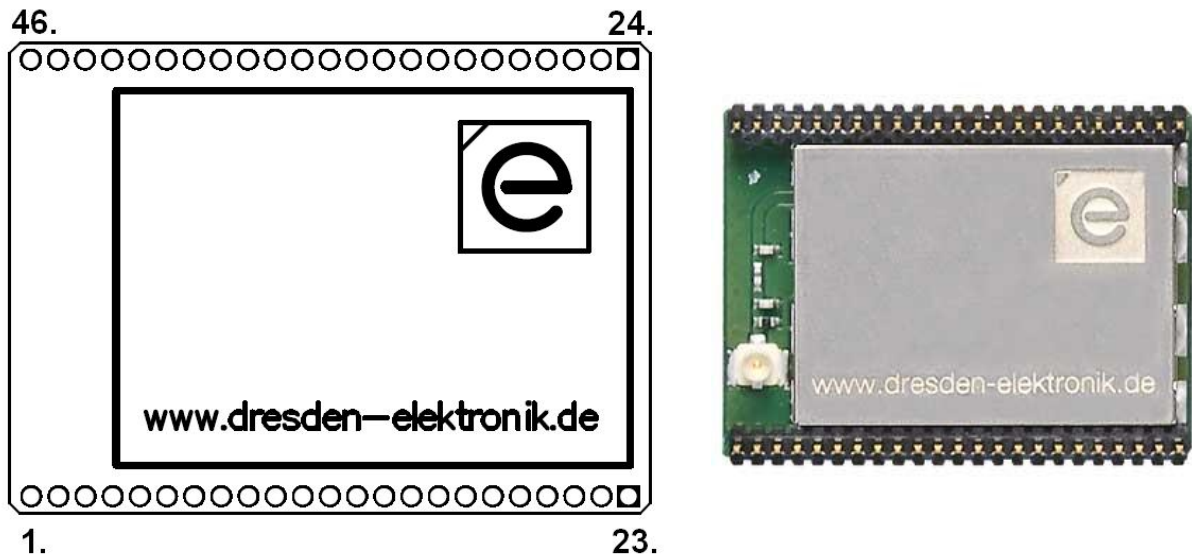

Figure 10: Top overlay deRFarm7-15A02

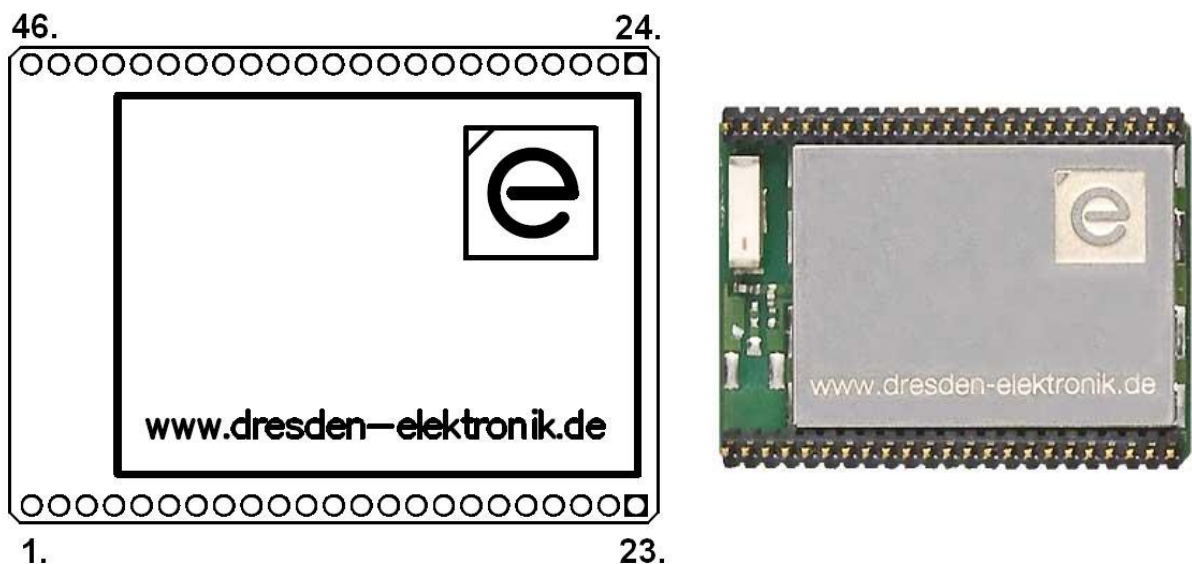

Figure 11: Top overlay deRFarm7-25A00

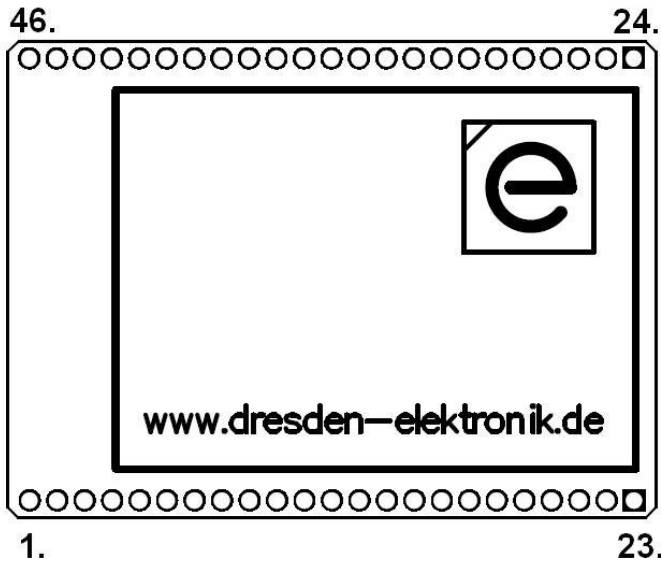
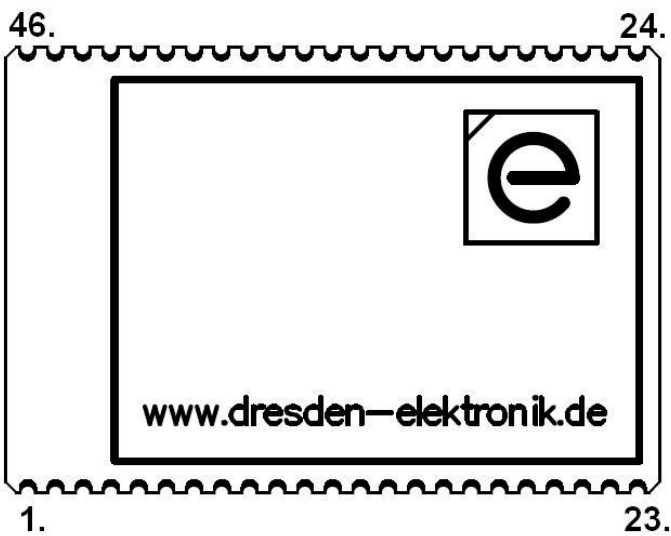
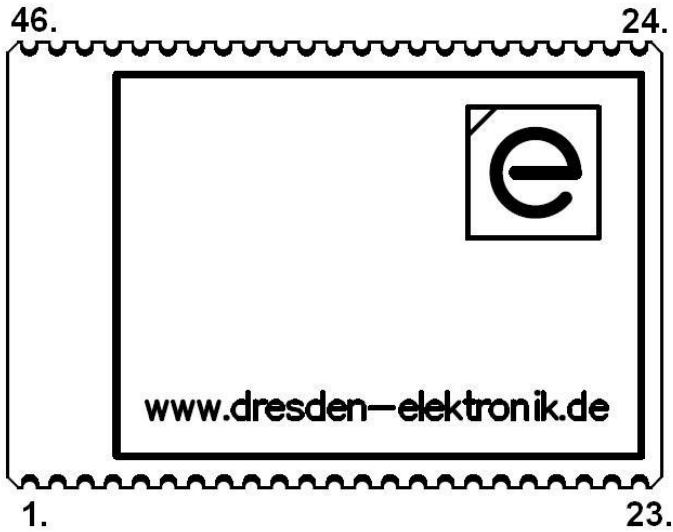

Figure 12: Top overlay deRFarm7-25A02



coming soon

Figure 13: Top overlay deRFarm7-15C02



coming soon

Figure 14: Top overlay deRFarm7-25C00

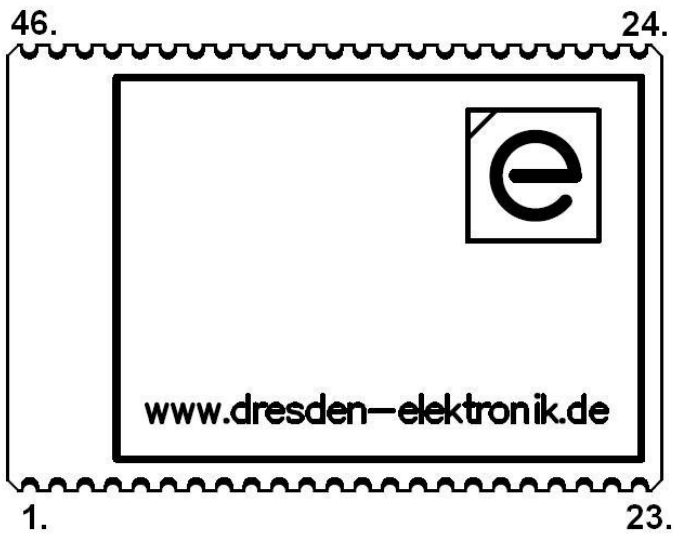

coming soon

Figure 15: Top overlay deRFarm7-25C02





## 7.1. External Pins

Table 6, Table 7 and Table 8 shows the external available signals of deRFarm7 radio modules.

**Table 6: Pin assignment of deRFarm7 – radio module family**

Pin assignment			
Pin	$\mu$ C-Port	Pin	$\mu$ C-Port
1	VCC	24	VCC
2	GND	25	GND
3	ADVREF	26	PA27/DRXD/PCK3
4	USBDM	27	PA0/RXD0
5	RSTN	28	PA28/DTXD
6	PB3/ETX1	29	PA4/CTS0/SPI1_NPCS3
7	PA11/TWCK	30	PB9/EMDIO
8	PB26/TIOB1/RI1	31	PB21/PWM2/PCK1
9	PA10/TWD	32	USBDP
10	PA1/ TXD0	33	PB19/PWM0/TCLK1
11	PB25/TIOA1/DTR1	34	PB27/TIOA2/PWM0/AD0
12	PB2/ETX0	35	PA14/SPI0_NPCS2/IRQ1
13	PA18/SPI0_SPCK	36	PB28/TIOB2/PWM1/AD1
14	PA3/RTS0/SPI1_NPCS2	37	PB5/ERX0
15	PA17/SPI0_MOSI	38	TCK
16	PB0/ETXCK/EREFCK	39	PB7/ERXER
17	PA16/SPI0_MISO	40	TMS
18	PB8/EMDC	41	PB1/ETXEN
19	PB6/ERX1	42	TDO
20	PB18/EF100/ADTRG	43	JTAGSEL
21	PB15/ERXDV/ECRSDV	44	TDI
22	GND	45	GND
23	GND	46	GND



**Table 7: Description of available I/O port pins**

Description of available I/O port pins on header pins				
I/O port pin	Alternate function (signal name)			Comments
PA0	RXD0			
PA1	TXD0			
PA3	RTS0			
PA4	CTS0			
PA10	TWD			
PA11	TWCK			
PA14	IRQ1			
PA16	SPI0_MISO			
PA17	SPI0_MOSI			
PA18	SPI0_SPCK			
PA27	DRXD	PCK3		
PA28	DTXD			
PB0	ETXCK/EREFCK	PCK0		
PB1	ETXEN			
PB2	ETX0			
PB3	ETX1			
PB5	ERX0			
PB6	ERX1			
PB7	ERXER			
PB8	EMDC			
PB9	EMDIO			
PB15	ERXDV/ECRSDV			
PB18	EF100	ADTRG		
PB19	PWM0	TCLK1		
PB21	PWM2	PCK1		
PB25	TIOA1	DTR1		
PB26	TIOB1	RI1		
PB27	TIOA2	PWM0	AD0	
PB28	TIOB2	PWM1	AD1	



**Table 8: Signal description list**

Signal name	Function	Type	Active Level	Comments
<i>Power</i>				
VCC	Voltage Regulator Power Supply Input	Power		3.0V to 3.6V
GND		Ground		
<i>JTAG</i>				
TCK	Test Clock	Input		On-board Pull-up
TDI	Test Data In	Input		On-board Pull-up
TDO	Test Data Out	Output		
TMS	Test Mode Select	Input		On-board Pull-up
JTAGSEL	JTAG Selection	Input		On-Board Pull-down
<i>Debug Unit</i>				
DRXD	Debug Receive Data	Input		
DTXD	Debug Transmit Data	Output		
<i>Reset</i>				
RSTN	Microcontroller Reset	I/O	Low	Pull-Up resistor
<i>Clocks, Oscillators</i>				
PCK0 - PCK3	Programmable Clock Output	Output		
<i>U[S]ART</i>				
TXD0	Transmit Data	I/O		
RXD0	Receive Data	Input		
RTS0	Request To Send	Output		
CTS0	Clear To Send	Input		
DTR1	Data Terminal Ready	Output		
RI1	Ring Indicator	Input		
<i>Timer/Counter and PWM Controller</i>				
TIOA1 – 2	I/O Line A	I/O		
TIOB1 – 2	I/O Line B	I/O		
TCLK1	External Clock Inputs	Input		
<i>PWM Controller</i>				
PWM0 - 2	PWM Channels	Output		
<i>Interrupt</i>				



Signal name	Function	Type	Active Level	Comments
IRQ1	External Interrupt Inputs	Input		
<i>SPI</i>				
SPI0_MISO	Master In / Slave Out	I/O		
SPI0_MOSI	Master Out / Slave In	I/O		
SPI0_SPCK	SPI Serial Clock	I/O		
SPI0_NPCS2	SPI Peripheral Chip Select 2	Output	Low	
SPI1_NPCS2	SPI Peripheral Chip Select 2	Output	Low	
SPI1_NPCS3	SPI Peripheral Chip Select 3	Output	Low	
<i>Two-Wire-Interface</i>				
TWD	Two-Wire Serial Interface Data	I/O		
TWCK	Two-Wire Serial Interface Clock	I/O		
<i>USB Device Port</i>				
USBDM	USB Device Port Data -	Analog		
USBDP	USB Device Port Data +	Analog		
<i>Analog-to-Digital Converter</i>				
AD0 – AD1	Analog Inputs	Analog		Digital pulled-up inputs at reset
ADTRG	ADC Trigger	Input		
ADVREF	ADC Reference	Analog		
<i>Ethernet MAC 10/100 (RMII Mode)</i>				
ETXCK/ EREFCK	Reference Clock	Input		RMII only
ETXEN	Transmit Enable	Output		
ETX0 – ETX1	Transmit Data	Output		
ERX0 – ERX1	Receive Data	Input		
ERXER	Receive Error	Input		
EMDC	Management Data Clock	Output		
EMDIO	Management Data Input/Output	I/O		
ERXDV/ ECRSDV	Carrier Sense and Data Valid	Input		RMII only
EF100	Force 100 Mbts/sec.	Output	High	RMII only



## 7.2. Internal Connections

Table 9 shows the internal signal connection between MCU and transceiver. This description is valid for all deRFarm7 radio modules.

**Table 9: Internal connection of MCU and Transceiver**

Pin assignment of ATSAM7X512 to AT86RF212 / AT86RF231					
<i>μC-Pin</i>	<i>μC-Port</i>	<i>TRX-Pin</i>	<i>TRX-Port</i>	<i>Type</i>	<i>Comments</i>
D1	PA23/TD/SPI1_MOSI	22	MOSI	Input	Master Out / Slave In
D2	PA24/RD/SPI1_MISO	20	MISO	Output	Master In / Slave Out
A1	PA22/TK/SPI1_SPCK	19	SCLK	Input	SPI Serial Clock
A2	PA21/TF/SPI1_NPCS0	23	SEL	Input	SPI Select
J1	PA29/FIQ/SPI1_NPCS3	24	IRQ	Output	1. Interrupt request signal 2. Frame Buffer Empty Indicator
H7	PA9/CTS1	8	RSTN	Input	Reset
C10	PA15/TCLK2	17	CLKM	Output	Master clock signal output, internal lowpass filter assembled
H8	PA8/RTS1	11	SLP_TR	Input	Controls sleep, transmit start, receive states
F2	PB23/TIOA0/DCD1	10	DIG2	Output	1. Antenna Diversity RF switch control 2. RX Frame Time Stamping

**Note:**

For best radio performance results it is recommended to deactivate the clock output. According to transceiver datasheet register 0x03 must be set to value 0x00 to deactivate CLKM.

## 8. Programming

### 8.1. Required hardware

Dresden elektronik ingenieurtechnik gmbh offers the hardware components for a fast startup. The following hardware setups are possible:

- deRFarm7 radio module
- deRFgateway or deRFnode (baseboard)
- SEGGER SAM-ICE<sup>1</sup> similar programmer

For example, to exchange the firmware of an ARM-based radio module, use the Atmel SAM-ICE JTAG Emulator. The programmer has to be plugged to the baseboard which is DC- or USB-powered.

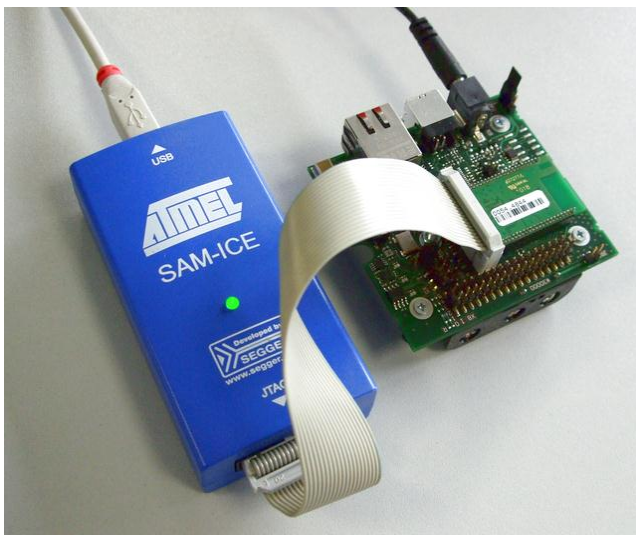

**Figure 16: SAM-ICE connected with baseboard plus plugged radio module**

<sup>1</sup> The SEGGER SAM-ICE programmer will **not** be offered by dresden elektronik ingenieurtechnik gmbh



## 8.2. Programming example

The described programming examples was done with Atmel's programming software 'SAM-BA v2.10', which is free downloadable on Atmel homepage. Install SAM-BA v2.10 on the PC or Laptop and connect the hardware described in section 8.1.

### 1. Start SAM-BA v2.10

The start screen (Figure 17) shows two selection tables. At first choose the connected SEGGER-SAM-ICE programmer (Figure 18) and then the connected board (Figure 19). In this case the assembled MCU is important for selection, that means choose AT91SAM7X512-EK.



Figure 17: SAM-BA start screen



Figure 18: SAM-BA start screen – Choose programmer

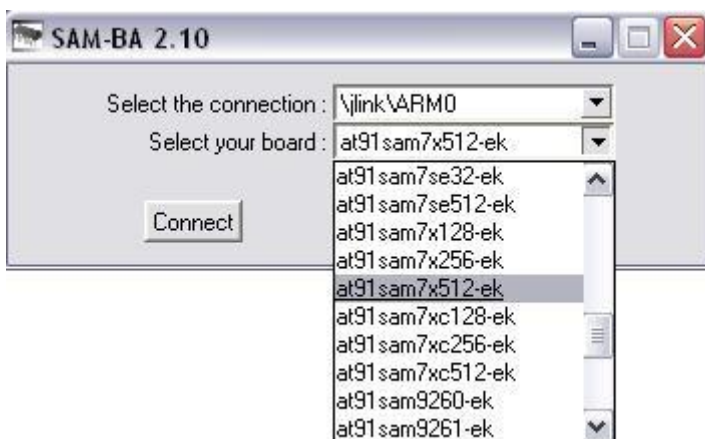

Figure 19: SAM-BA start screen – Choose MCU



- Click 'CONNECT' to get to the SAM-BA main screen (Figure 20)  
If there appears an error message, check if the target board is supplied via USB and/or DC and if the JTAG cable is plugged in the right polarization.

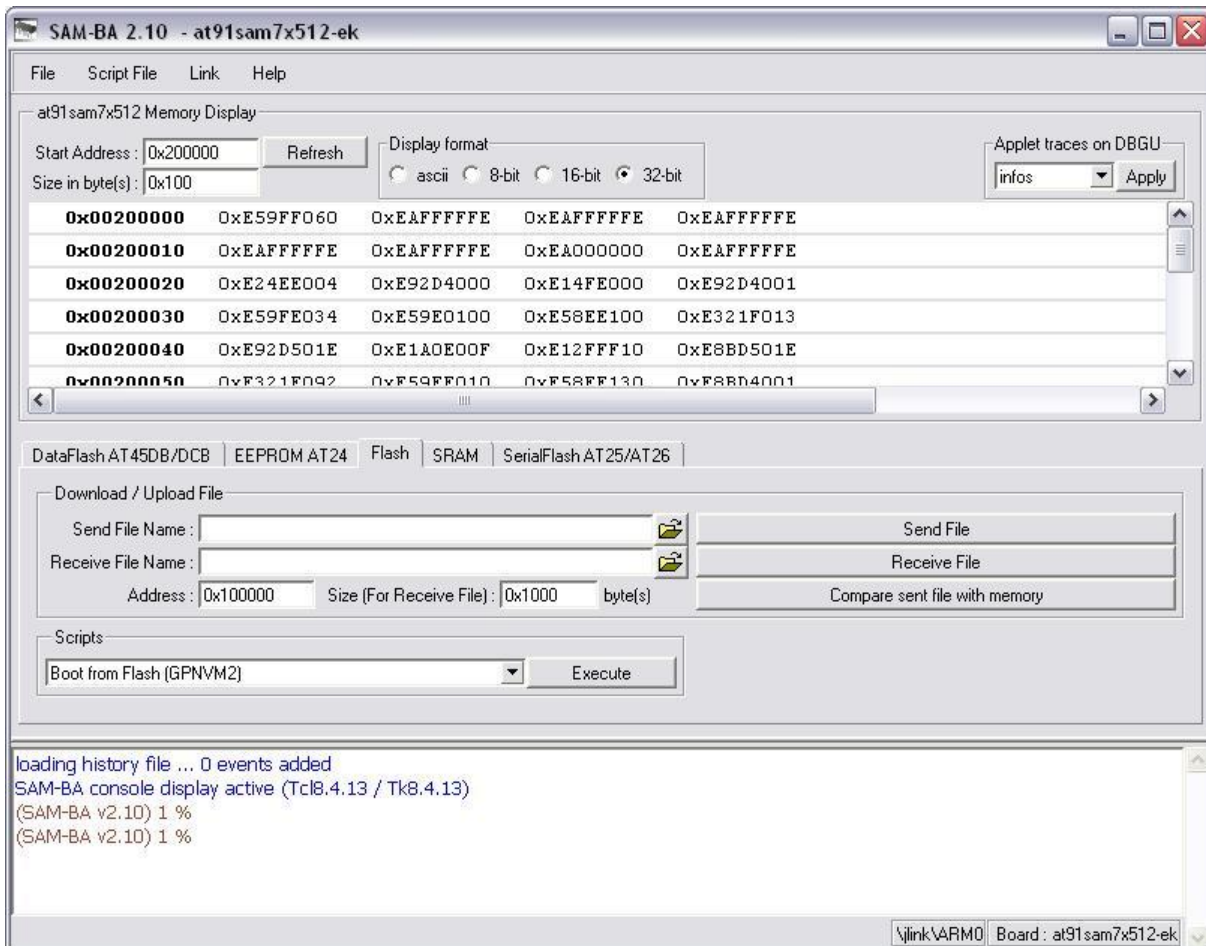

Figure 20: SAM-BA main screen





3. Before programming the MCU flash, it is necessary to erase the internal flash. Select the script 'ERASE ALL FLASH' and click 'EXECUTE' (Figure 21). Be careful: the whole internal flash content will be deleted.

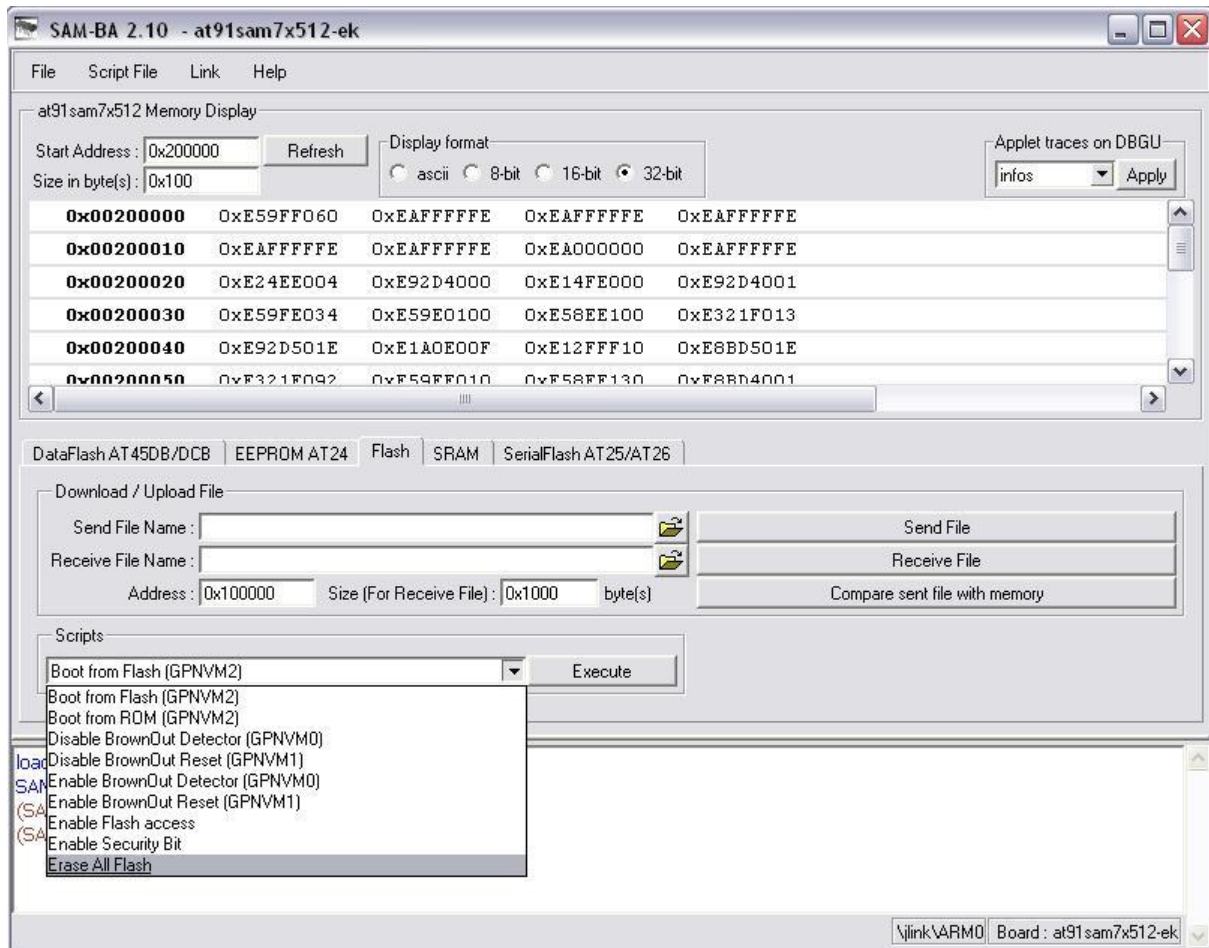

Figure 21: SAM-BA erasing the internal flash



4. After erasing the flash content choose the binary file which must be flash on target MCU. Click on the 'OPEN DIRECTORY' button in the "DOWNLOAD/UPLOAD FILE" section next to 'SEND FILE NAME' (Figure 22). Click on 'SEND FILE' button to flash the binary.

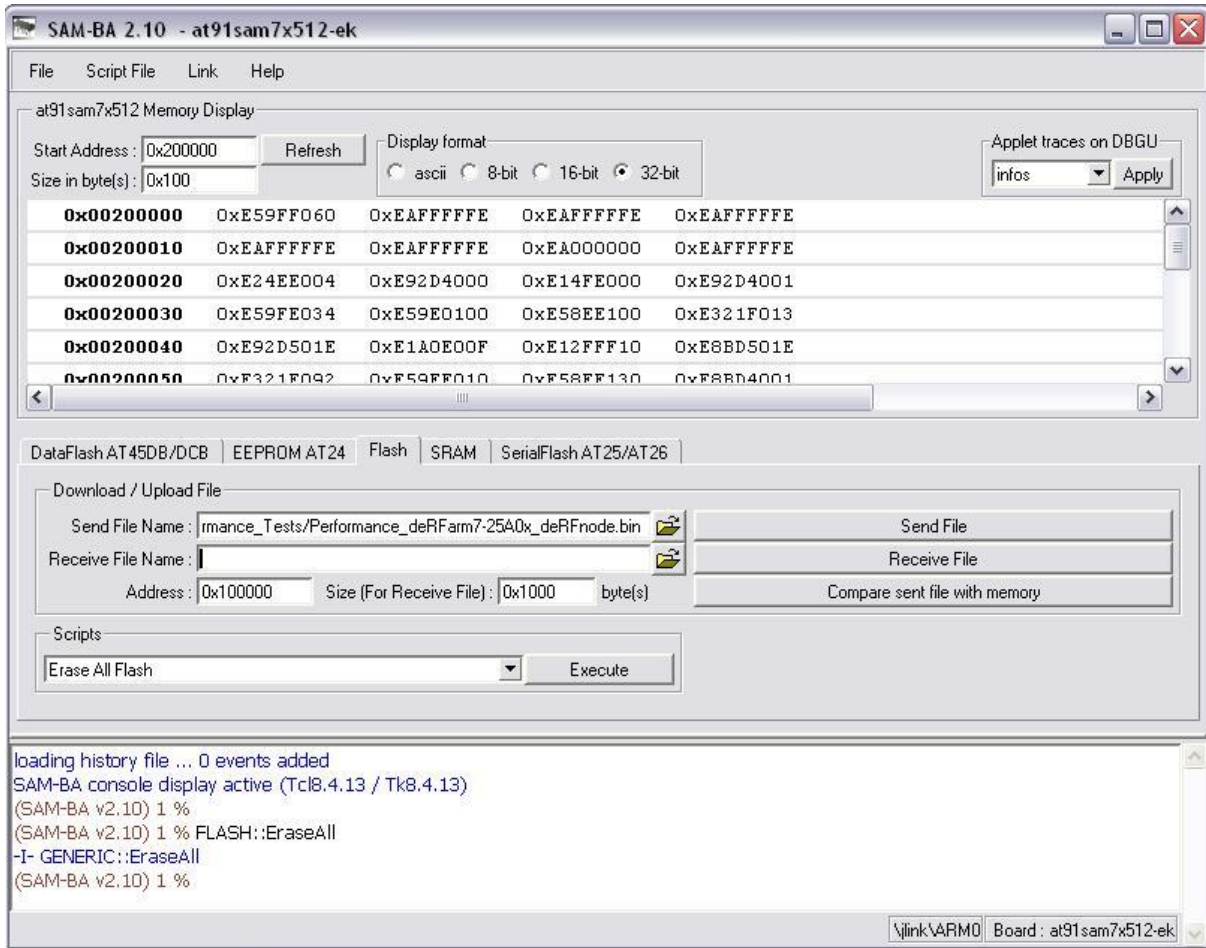

Figure 22: SAM-BA choosing binary



5. After flashing the binary SAM-BA asked for locking the flash content. Click 'NO' (Figure 23).

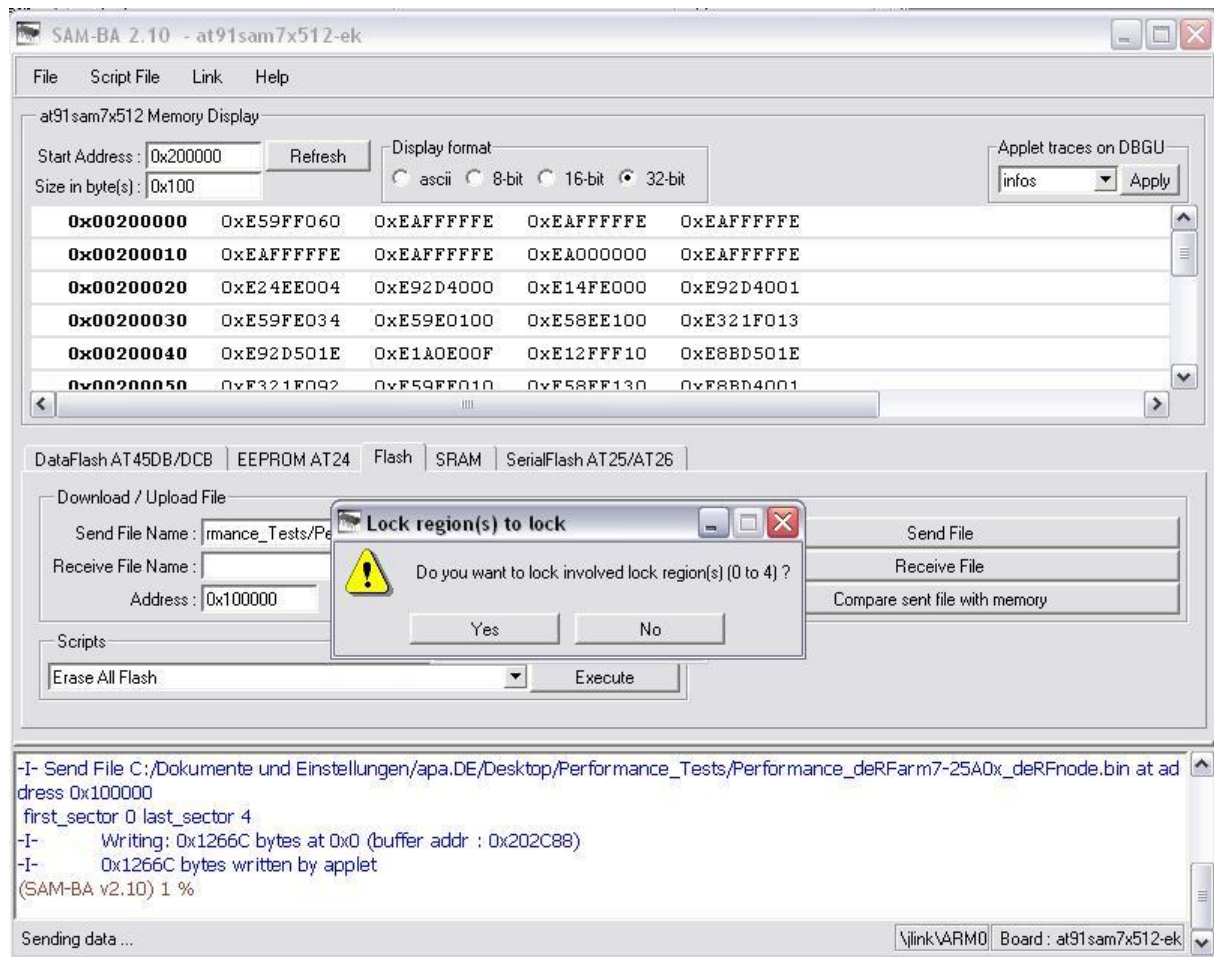
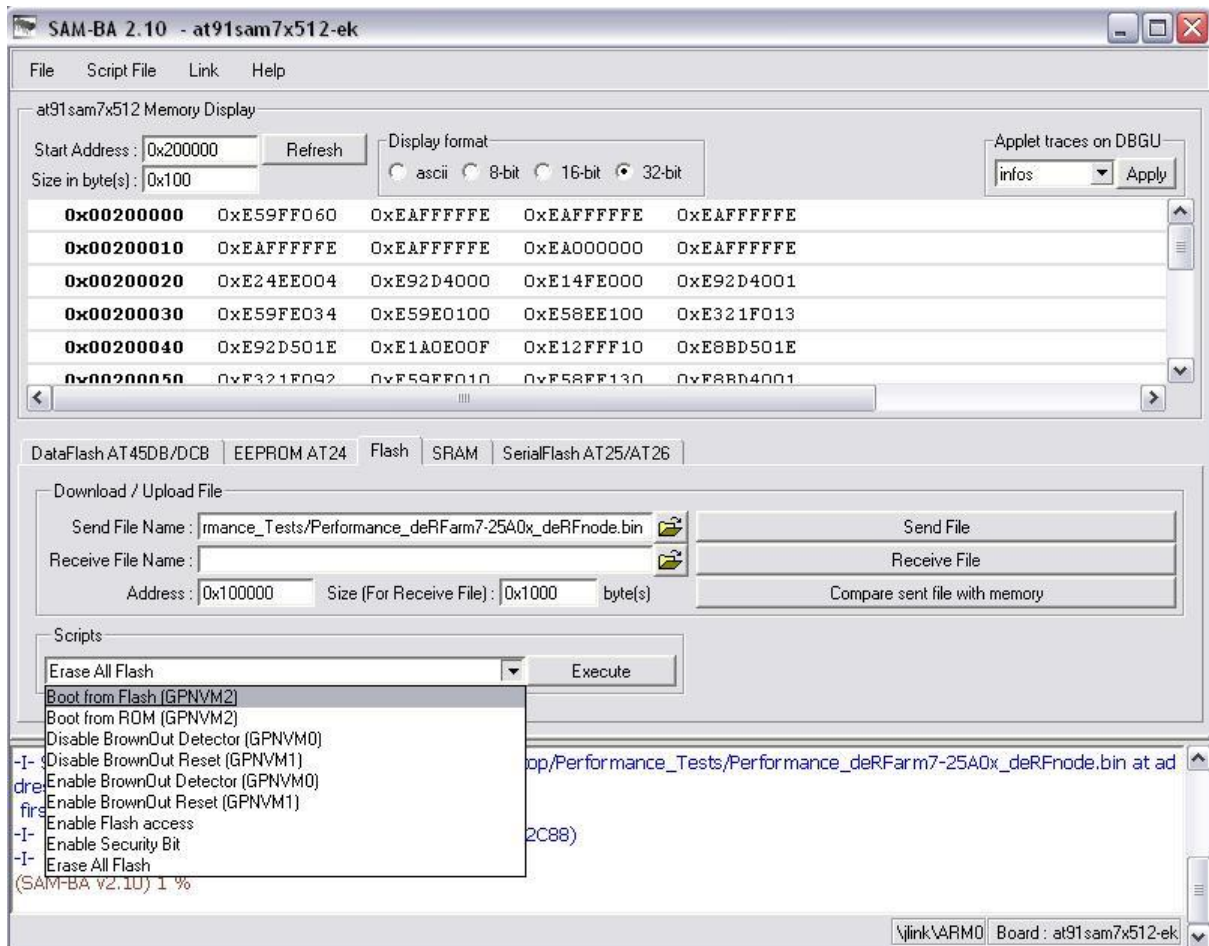

Figure 23: SAM-BA lock regions



- The last action is to set the GPNVM2 bit in the boot from flash mode. Just select and execute the script 'BOOT FROM FLASH' (Figure 24).



**Figure 24: SAM-BA boot from flash**

- Close SAM-BA, disconnect the SEGGER-SAM-ICE programmer and re-power the target. The new MCU firmware starts now from the internal flash.



## 8.3. JTAG interface

All deRFarm7 variants are programmable over JTAG interface (TDI, TDO, TCK, TMS). The radio module contains all necessary pull-up resistors onboard. Use the pin configuration shown in Figure 25 to connect the radio module to a suitable ARM programmer like the SEGGER SAM-ICE.

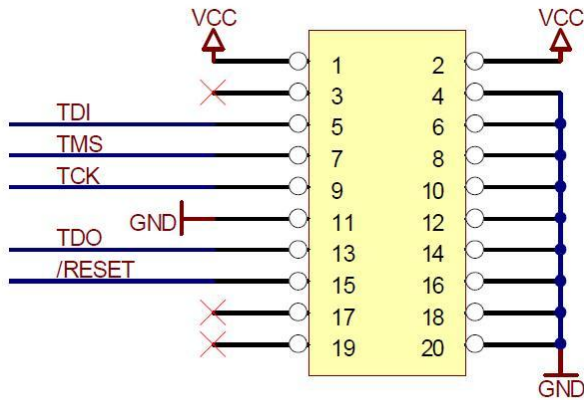

Figure 25: ARM JTAG interface

## 9. Debugging and tracing

Debugging and tracing of the radio module is possible with the RS232-Level-Shifter. This component is offered by dresden elektronik ingenieurtechnik gmbh. The used pin connection to connect the radio module to a suitable debug and trace hardware is shown in Figure 26.

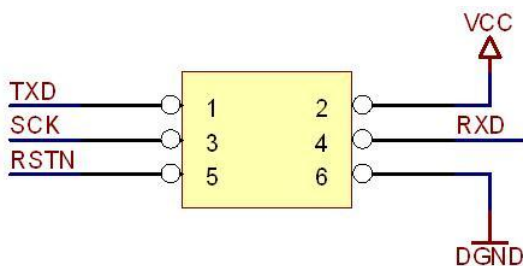

Figure 26: Debug interface

## 10. RF components

### 10.1. deRFarm7-15A02 / 15C02

The U.FL coaxial connector contains a filter network:

- L2 = 10nH (0402)
- C1 = 4.7pF (0402)
- C3 = 4.7pF (0402)

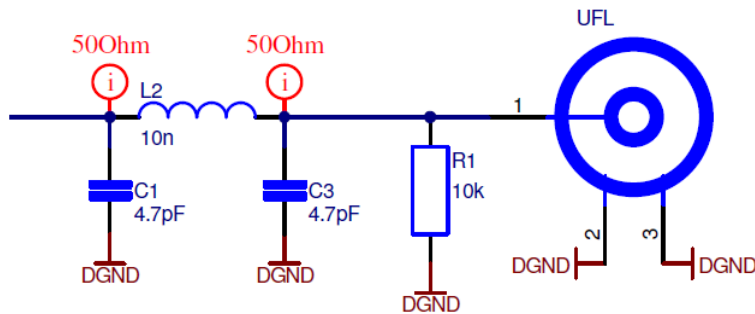

Figure 27: Filter network of deRFarm7-15A02

### 10.2. deRFarm7-25A00 / 25C00

The chip antenna on the deRFarm7-25A00 is matched with:

- L1 = 1.0nH (0402)
- L2 = 2.2nH (0402)

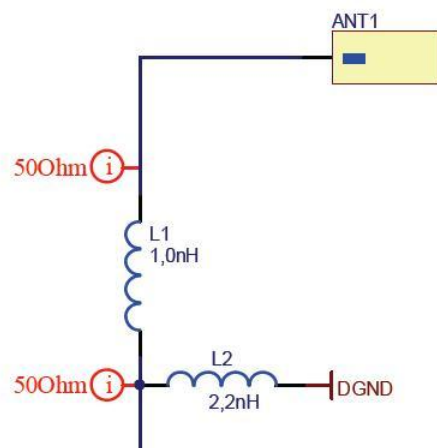

Figure 28: Matching network of deRFarm7-25A00

### 10.3. deRFarm7-25A02 / 25C02

The U.FL coaxial connector contains a filter network:

- L2 = 1.0pF (0402) (assembly variant of deRFarm7-25A00)
- C19 = 22pF (0402)

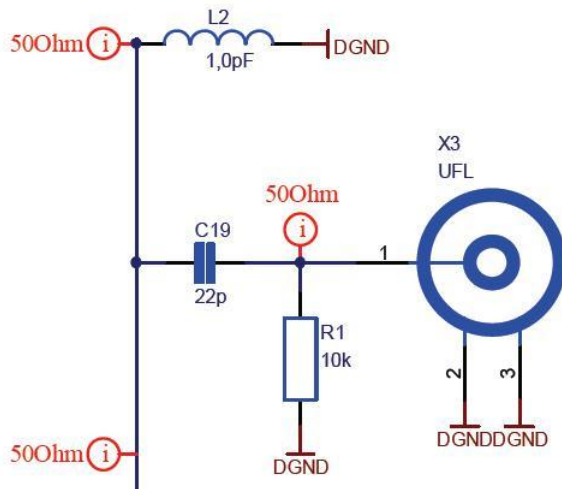

Figure 29: Matching network of deRFarm7-25A02





## 11. Radio certification

### 11.1. United States (FCC)

The deRFarm7-15A02, deRFarm7-25A00, deRFarm7-25A02, deRFarm7-15C02, deRFarm7-25C00, deRFarm7-25C02 radio modules comply with the requirements of FCC part 15.

To fulfill FCC Certification requirements, an OEM manufacturer must comply with the following regulations:

The modular transmitter must be labeled with its own FCC ID number, and, if the FCC ID is not visible when the module is installed inside another device, then the outside of the device into which the module is installed must also display a label referring to the enclosed module.

This exterior label can use wording such as the following. Any similar wording that expresses the same meaning may be used.

#### Sample label for radio module deRFarm7-25A00 and deRarm7-25C00:

**FCC-ID: XVV-ARM725A00**

*This device complies with Part 15 of the FCC Rules. Operation is subject to the following two conditions: (1) this device may not cause harmful interference, and (2) this device must accept any interference received, including interference that may cause undesired operation.*

#### Sample label for radio module deRFarm7-25A02 and deRarm7-25C02:

**FCC-ID: XVV-ARM725A02**

*This device complies with Part 15 of the FCC Rules. Operation is subject to the following two conditions: (1) this device may not cause harmful interference, and (2) this device must accept any interference received, including interference that may cause undesired operation.*

#### Sample label for radio module deRFarm7-15A02:

**FCC-ID: XVV-ARM715A02**

*This device complies with Part 15 of the FCC Rules. Operation is subject to the following two conditions: (1) this device may not cause harmful interference, and (2) this device must accept any interference received, including interference that may cause undesired operation.*

Note: The radio modules deRFarm7-15C02, deRFarm7-25C00 and deRFarm7-25C02 fulfill a Permissive Change Class 1 regarding to FCC Section 2.1043 and complies with the requirements of FCC part 15.

To be used with the deRFarm7-15A02, deRFarm7-25A02 modules, the external antenna have been tested and approved which is specified in here below. The deRFarm7-15A02, deRFarm7-25A02 modules may be integrated with other custom design antennas which OEM installer must authorize following the FCC 15.21 requirements.

The Original Equipment Manufacturer (OEM) must ensure that the OEM modular transmitter is labeled with its own FCC ID number. This includes a clearly visible label on the outside of the final product enclosure that displays the contents shown below. If the FCC ID is not visi-





ble when the equipment is installed inside another device, then the outside of the device into which the equipment is installed must also display a label referring to the enclosed equipment.

This equipment complies with Part 15 of the FCC Rules. Operation is subject to the following two conditions: (1) this device may not cause harmful interference, and (2) this device must accept any interference received, including interference that may cause undesired operation (FCC 15.19). The internal / external antenna(s) used for this mobile transmitter must provide a separation distance of at least 20 cm from all persons and must not be co-located or operated in conjunction with any other antenna or transmitter.

Installers must be provided with antenna installation instructions and transmitter operating conditions for satisfying RF exposure compliance. This device is approved as a mobile device with respect to RF exposure compliance, and may only be marketed to OEM installers. Use in portable exposure conditions (FCC 2.1093) requires separate equipment authorization.

Modifications not expressly approved by this company could void the user's authority to operate this equipment (FCC section 15.21).

This equipment has been tested and found to comply with the limits for a Class A digital device, pursuant to Part 15 of the FCC Rules. These limits are designed to provide reasonable protection against harmful interference when the equipment is operated in a commercial environment. This equipment generates, uses, and can radiate radio frequency energy and, if not installed and used in accordance with the instruction manual, may cause harmful interference to radio communications. Operation of this equipment in a residential area is likely to cause harmful interference in which case the user will be required to correct the interference at his own expense (FCC section 15.105).

## 11.2. European Union (ETSI)

The deRFarm7-15A02, deRFarm7-15C02, deRFarm7-25A00, deRFarm7-25C00, deRFarm7-25A02 and deRFarm7-25C02 modules have been tested compliant for use in European Union countries.

If the deRFarm7-15A02, deRFarm7-15C02, deRFarm7-25A00, deRFarm7-25C00, deRFarm7-25A02 and deRFarm7-25C02 modules are incorporated into a product, the manufacturer must ensure compliance of the final product to the European harmonized EMC and low-voltage/safety standards. A Declaration of Conformity must be issued for each of these standards and kept on file as described in Annex II of the R&TTE Directive.

The manufacturer must maintain a copy of the deRFarm7-15A02, deRFarm7-15C02, deRFarm7-25A00, deRFarm7-25C00, deRFarm7-25A02 and deRFarm7-25C02 modules documentation and ensure the final product does not exceed the specified power ratings, antenna specifications, and/or installation requirements as specified in the user manual. If any of these specifications are exceeded in the final product, a submission must be made to a notified body for compliance testing to all required standards.

The "CE" marking must be affixed to a visible location on the OEM product. The CE mark shall consist of the initials "CE" taking the following form:



- If the CE marking is reduced or enlarged, the proportions given in the above graduated drawing must be respected.
- The CE marking must have a height of at least 5mm except where this is not possible on account of the nature of the apparatus
- The CE marking must be affixed visibly, legibly, and indelibly.

More detailed information about CE marking requirements you can find at "DIRECTIVE 1999/5/EC OF THE EUROPEAN PARLIAMENT AND OF THE COUNCIL" on 9 March 1999 at section 12.

### 11.3. Approved antennas

The deRFarm7-25A00 has an integrated chip antenna. The design is fully compliant with all regulations.

The deRFarm7-15A02 has been tested and approved for use with the antenna listed below. The module may be integrated with other custom design antennas which OEM installer must authorize with respective regulatory agencies. The used antenna was connected to the radio module with a 15cm "U.FL-to-SMA pigtail".

**Table 10: Approved antenna(s) and accessory**

Approved antenna(s) and accessory				
Part number	Description	Manufacturer	Gain [dBi]	Min. Separation [cm]
ANT-916-CW-HWR-RPS	½ wave whip antenna (915 MHz) with RP-SMA-Connector	Antenna Factor	0	20
PSKN3-2400RS	½ wave whip antenna (2450 MHz) with RP-SMA-Connector	Mobile Mark	2.3	20
BN-032125	U.FL to RP-SMA pigtail, 15 cm	Hirose / Profineon	-0,35	



## 12. Ordering information

The product name includes the following information:

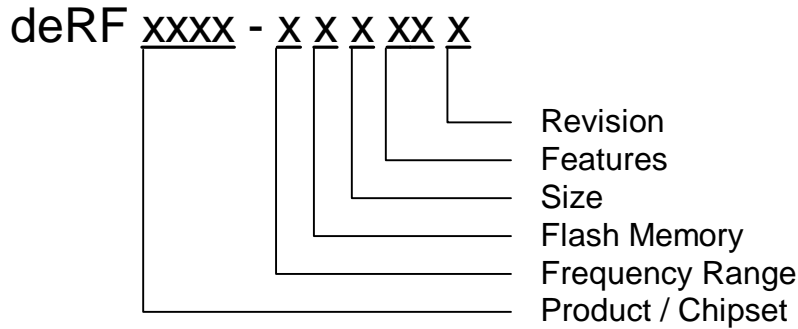

Table 11: product name code

Product name code			
Information	Code	Explanation	Comments
Product / Chipset	arm7	AT91SAM7X	radio module
Frequency range	1	780/868/915 MHz	
	2	2.4 GHz	
Flash memory	5	512 kByte	
Size	A	30 x 22.7 mm	pluggable
	C	30 x 20.4 mm	solderable
Features	00	chip antenna	onboard
	02	coaxial connector	onboard U.FL
Revision	<blank>	Rev 0	
	1	Rev 1	



**Table 12: ordering information**

<b>Ordering information</b>		
<i>Part number</i>	<i>Product name</i>	<i>Comments</i>
coming soon	deRFarm7-15A00	pluggable Sub-GHz radio module with onboard chip antenna
coming soon	deRFarm7-15C00	solderable Sub-GHz radio module with onboard chip antenna
BN-030974	deRFarm7-15A02	pluggable Sub-GHz radio module with onboard U.FL coaxial connector
coming soon	deRFarm7-15C02	solderable Sub-GHz radio module with onboard U.FL coaxial connector
BN-027264	deRFarm7-25A00	pluggable 2.4-GHz radio module with onboard chip antenna
coming soon	deRFarm7-25C00	solderable 2.4-GHz radio module with onboard chip antenna
BN-027265	deRFarm7-25A02	pluggable 2.4-GHz radio module with onboard U.FL coaxial connector
coming soon	deRFarm7-25C02	solderable 2.4-GHz radio module with onboard U.FL coaxial connector



---

## 13. Revision notes

Up to now for the deRFarm7-15A02, deRFarm7-25A00, deRFarm7-25A02, deRFarm7-15C02, deRFarm7-25C00 and deRFarm7-25C02 radio modules technical problems, malfunctions or any other critical issues are not known.



dresden elektronik ingenieurtechnik gmbh  
Enno-Heidebroek-Straße 12  
D-01237 Dresden

Tel. +49 351 - 31 85 00 | Fax +49 351 - 318 50 10  
E-Mail [wireless@dresden-elektronik.de](mailto:wireless@dresden-elektronik.de)  
General manager: Dipl.-Ing. L. Pietschmann  
Commercial Registry: HRB 749 Dresden Municipal Court  
Tax number: 201/107/00726  
Sales tax identification number: DE 140125678

## Trademarks and acknowledgements

- ZigBee® is a registered trademark of the ZigBee Alliance.
  - 802.15.4 is a trademark of the Institute of Electrical and Electronics Engineers (IEEE).
- These trademarks are registered by their respective owners in certain countries only. Other brands and their products are trademarks or registered trademarks of their respective holders and should be noted as such.

## Disclaimer

This note is provided as-is and is subject to change without notice. Except to the extent prohibited by law, dresden elektronik ingenieurtechnik gmbh makes no express or implied warranty of any kind with regard to this guide, and specifically disclaims the implied warranties and conditions of merchantability and fitness for a particular purpose. dresden elektronik ingenieurtechnik gmbh shall not be liable for any errors or incidental or consequential damage in connection with the furnishing, performance or use of this guide.

No part of this publication may be reproduced, stored in a retrieval system, or transmitted in any form or any means electronic or mechanical, including photocopying and recording, for any purpose other than the purchaser's personal use, without the written permission of dresden elektronik ingenieurtechnik gmbh.

Copyright © 2011, dresden elektronik ingenieurtechnik gmbh All rights reserved