



Tenso-set™ Series 600 Auto-Tensioning Motor Base Installation and Maintenance Manual

Emerson Industrial Automation
7120 New Buffington Road
Florence, KY 41042
Application Engineering: 800 626 2093
www.PowerTransmissionSolutions.com

FORM
9884E
June 2014

⚠ WARNING

- Read and follow all instructions carefully.
- Disconnect and lock-out power before installation and maintenance. Working on or near energized equipment can result in severe injury or death.
- Avoid contact with energized circuits or rotating parts.
- Be sure shaft key is fully captive before unit is energized.
- Do not operate equipment without guards in place. Exposed equipment can result in severe injury or death.

⚠ CAUTION

- Periodic inspections should be performed. Failure to perform proper maintenance can result in premature product failure and personal injury.
- All electrical work should be performed by qualified personnel and compliant with local and national electrical codes.

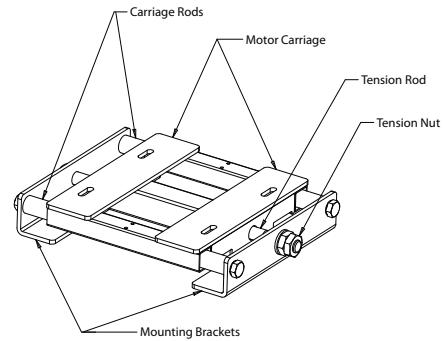
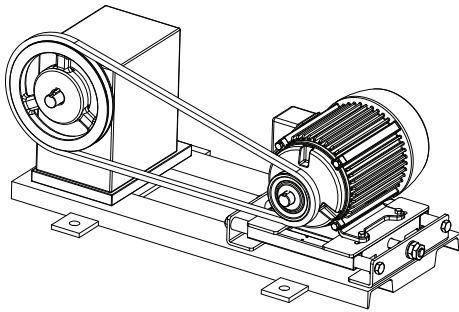

Installation Instructions

1. Mount the motor on the motor base using the recommended grade 5 bolts and torques listed in table 1.
2. Mount the sheaves on the Driver and Driven Shafts.

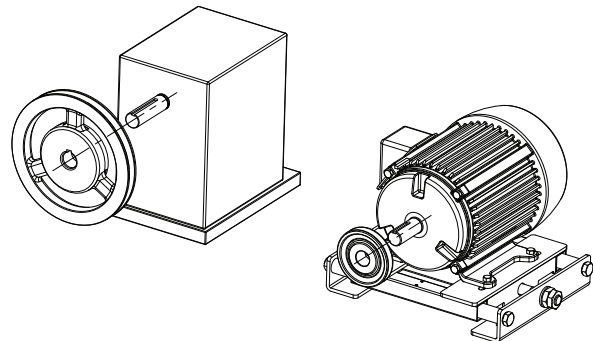
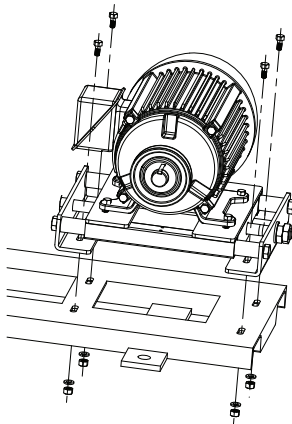
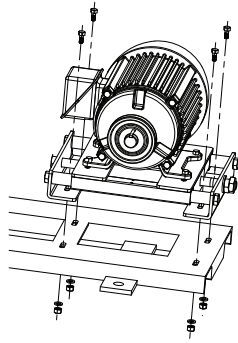

Table 1

Motor Base	Bolt Size	Torque (Grade 5 plated)
BSAMBN601	5/16-18	13 Lb-Ft
BSAMBN605	3/8-16	23 Lb-Ft
BSAMBN607	3/8-16	23 Lb-Ft
BSAMBN613	3/8-16	23 Lb-Ft
BSAMBN621	1/2-13	57 Lb-Ft
BSAMBN623	1/2-13	57 Lb-Ft

3. Mount the motor base using the recommended grade 5 bolts (Leave the bolts loose enough to allow the motor base to be moved to align the sheaves)



4. Set the motor base carriage to the center of the motor base by adjusting the tension rod until dimension A and B are equal.

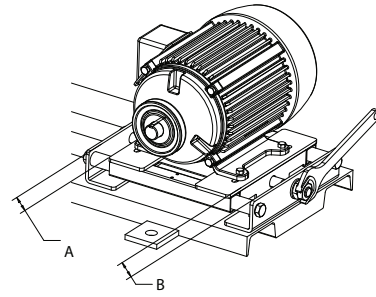

5. Align the motor base to position the sheaves in the proper location. A straight edge should be used to align the sheave to be parallel and in the same plane. When this is achieved the straight edge will be flush to the sides of both sheaves as shown.

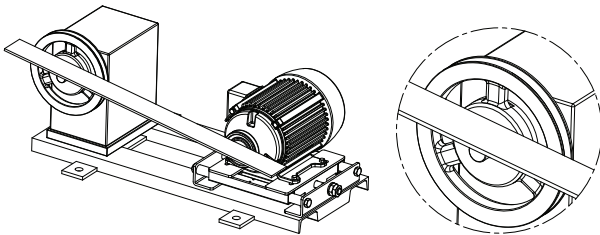

6. Tighten the motor base mounting bolts using the recommended grade 5 bolts and torques listed in table 1.

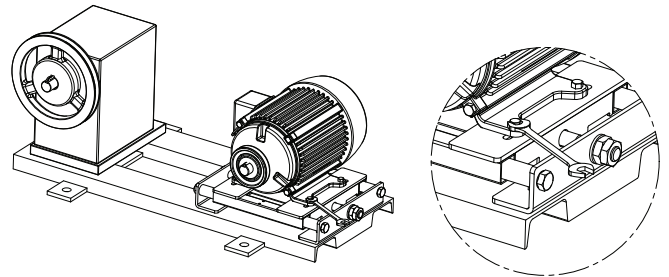

7. Rotate the tension rod counterclockwise enough to allow the belt to slip over the two sheaves by hand. (Prying the belts over the sheaves with any device can damage the belts or sheaves)

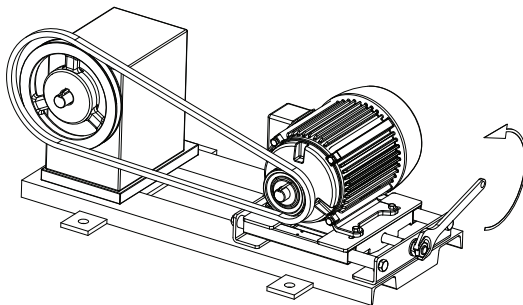

8. Manually pull the motor base back by hand in the direction shown and rotate the tension rod clockwise until hand tight.

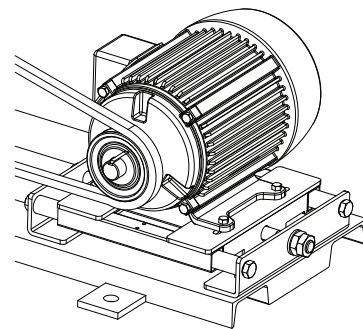

9. Use a wrench to tighten the tension rod turning clockwise until the belt feels tight.

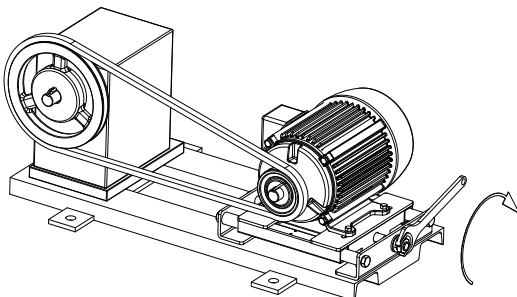

10. Check the belt tension using Browning Belt Tension Checker.

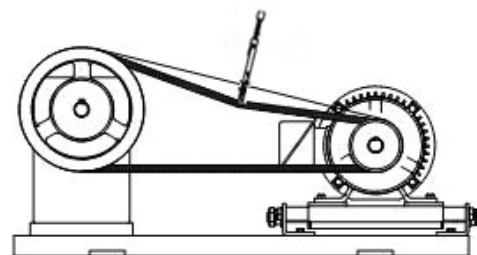

11. Adjust the tension screw until the proper belt tension is recorded by the Browning Belt Tension Checker. The recommended deflection force is 150 percent of the Edge value or the value given for a new belt in form 5453 included with the Browning Belt Tension Checker

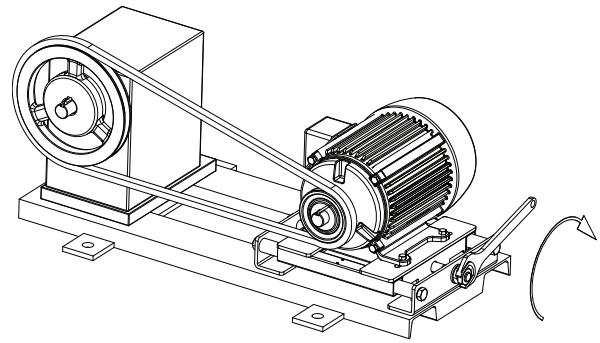

WARNING! The surface on which the Motor Base is mounted must be flat. A base that is distorted or warped will not function properly. If the surface is not flat, correct the condition with shims.

Maintenance

Lubrication

The carriage tubes are provided with holes or fitting for lubrication. Every six months or as dictated by the application, wipe down the carriage rails and tension rod with an oily rag and apply a light grade grease. Be sure to remove all foreign material from the tubes and tension rod.

Changing Belts

Turn the tension rod counter clockwise to move the carriage enough to allow the old belt to be removed.

Repeat steps 7 through 11 of the installation instructions to install the new belt.

Adjusting Belts

Periodic adjustment should not be needed. However, if it is suspected that the belt tension is not correct, then complete steps 10 and 11 of the installation instructions.

Allowable Mounting Positions

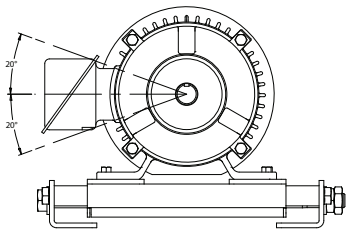

Floor Mounted

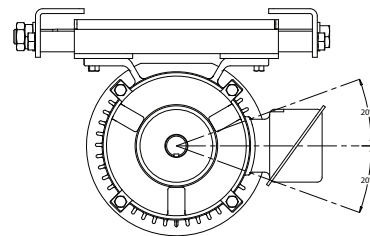

Ceiling Mounted

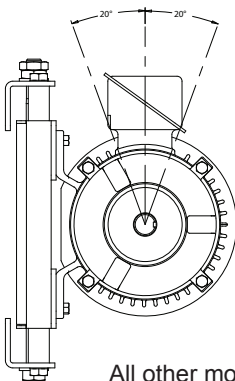

Wall Mounted Driven
Above Driver

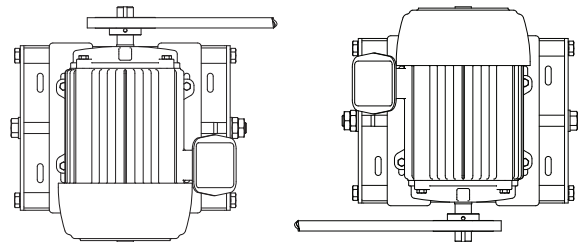

Wall Mounted Driven
beside Driver

All other mounting positions contact Application Engineering.