

HITACHI

Backpack Blower

RB 65EF

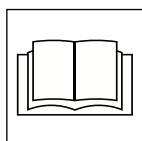
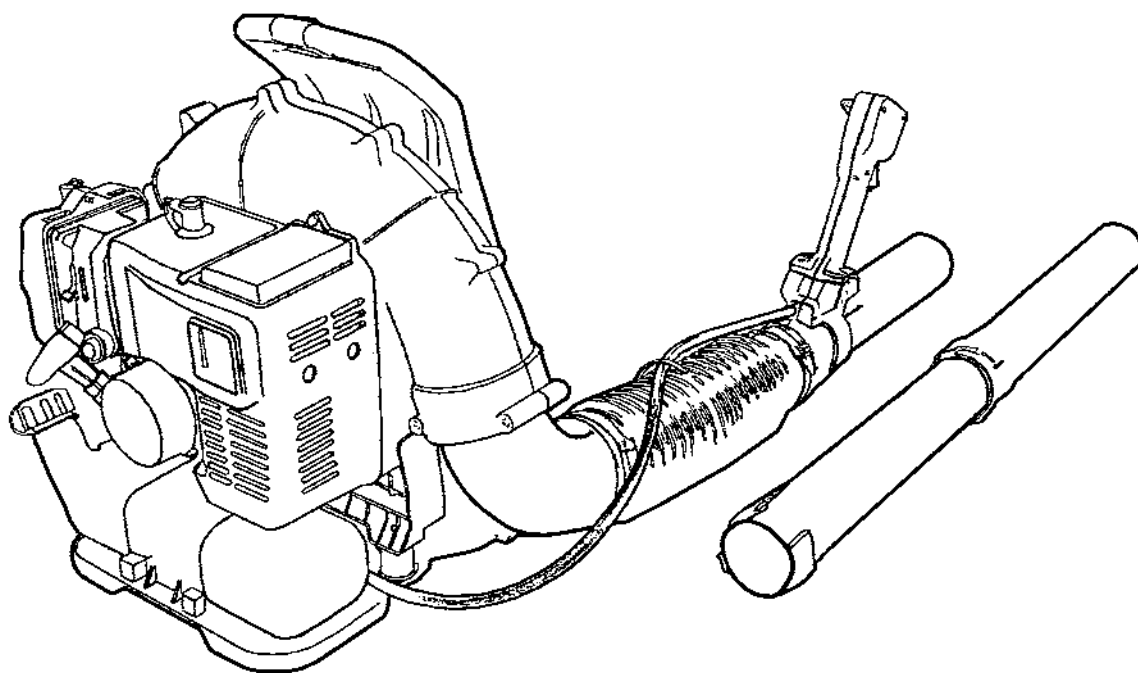

Read the manual carefully before operating this machine.

Handling instructions

Hitachi Koki

970-41910-200 2010.06

MEANINGS OF SYMBOLS

NOTE!

Some units do not carry them.

 **WARNING!**
The following show symbols used for the machine. Be sure that you understand their meaning before use.

Symbols



WARNING!

Careless or incorrect use of the blower can result in serious damage or fatal injury to the operator or others.



It is important that you read, fully understand and observe the following safety precautions and warnings. Careless or improper use of the unit may cause serious or fatal injury.



Always use

- A protective helmet where there is a risk of falling objects
- Ear protection
- Approved eye protection



- Always wear approved protective gloves.



- Use anti-slip and stable boots.



- **WARNING!** The blower may throw objects at high velocity that can ricochet and hit the operator. This may cause serious eye damage.



- The blower operator must make sure that no bystanders or animals come nearer than 10 metres. Whenever several operators are working in the same work area, they should maintain a safe distance of at least 10 metres from one another.

Other symbols/decals on the machine refer to special certification requirements for certain markets.

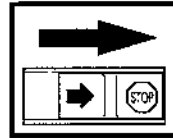

Checks and/or maintenance should be carried out with the engine switched off, with the stop switch in the STOP position.

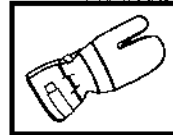

Always wear approved protective gloves.

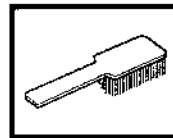

Regular cleaning required.

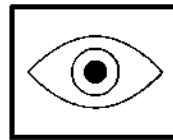

Visual inspection.



Approved eye protection must always be used.

CONTENTS



WARNING!
Under no circumstances should you modify the original design of the blower without approval from the manufacturer. Always use genuine spare parts. Unauthorised modifications or accessories may lead to serious injury or death.

EMISSION CONTROL INFORMATION

Fuel Information

THIS ENGINE IS CERTIFIED TO OPERATE ON UNLEADED REGULAR GRADE GASOLINE ONLY.

A minimum of 87 octane of the antiknock index is recommended. The antiknock index is posted on service station pumps in the Europe.

Emission Control Information

To protect the environment in which we all live, Kawasaki has incorporated an exhaust emission control system in compliance with applicable regulations of the United States Environmental Protection Agency and the California Air Resources Board. Also, depending on when your engine was produced, it may have an assigned emissions durability period. See below for the engine emissions durability period that may apply to your engine.

Exhaust Emission Control System

This system reduces the amount of pollutants discharged into the atmosphere by the exhaust of this engine. The fuel, ignition and exhaust systems of this engine have been carefully designed and constructed to ensure an efficient engine with low exhaust pollutant levels.

Maintenance and Warranty

Proper maintenance is necessary to ensure that your engine will continue to have low emission levels. This Handling instructions contains those maintenance recommendations for your engine. Those items identified by the Periodic Maintenance Chart are necessary to ensure compliance with the applicable standards.

As the owner of the Blower, you have the responsibility to make sure that the recommended maintenance is carried out according to the instructions in this Handling instructions at your own expense.

The Kawasaki Limited Emission Control System Warranty requires that your return your engine to an authorized Hitachi koki Dealer for remedy under warranty. Please read the warranty carefully, and keep it valid by complying with the owner's obligations it contains.

Engine Emissions Compliance Period

California	All Other States
Model Year - 2000 and later Durability Period - 300 hours	Engines less than 50cc Model Year - 2002 and later Durability Period - 300 hours (Category A)
	Engines 50cc and more Model Year - 2004 and later Durability Period - 300 hours (Category A)

If your engine has an assigned emissions durability period it will be located on the certification label attached to the engine (IMPORTANT ENGINE INFORMATION).

Tampering with Emission Control System Prohibited

Federal law and California State law prohibits the following acts or the causing thereof: (1) the removal or rendering inoperative by any person other than for purposes of maintenance, repair, or replacement, of any device or element of design incorporated into any new engine for the purposes of emission control prior to its sale or delivery to the ultimate purchaser or while it is in use, or (2) the use of the engine after such device or element of design has been removed or rendered inoperative by any person.

Among those acts presumed to constitute tampering are the acts listed below:

Do not tamper with the original emission related parts:

- Carburetor and internal parts
- Spark Plug
- Magneto or electronic ignition system
- Fuel Filter
- Muffler or any internal portion of the muffler
- Air cleaner element

List of contents

MEANINGS OF SYMBOLS

Symbols 2

CONTENTS

List of contents 3

SAFETY INSTRUCTIONS

Personal protective equipment 4

The machine's safety equipment 4

Inspection, maintenance and service of the machine's safety equipment 6

General safety instructions 7

General working instructions 8

Basic working techniques 9

WHAT IS WHAT?

What is what on the blower? 10

ASSEMBLY

Assembly of the blower 11

FUEL HANDLING

Fuel mixture 12

Fueling 13

STARTING AND STOPPING

Start and stop 14

MAINTENANCE

Periodic Maintenance chart 15

Muffler 16

Cooling system 16

Spark plug 16

Air filter 17

Maintenance schedule 18

TECHNICAL DATA

RB 65EF 19

SAFETY INSTRUCTIONS

Personal protective equipment

IMPORTANT INFORMATION

- A blower used incorrectly or carelessly can become a dangerous tool, which can cause serious damage or fatal injury to the operator or others. It is very important that you read and understand the content in this manual.
- When using a blower, personal protective equipment approved by the appropriate authorities must be used. Personal protective equipment does not eliminate the risk of accidents, but it reduces the effects of an injury in the event of an accident. Ask your dealer for help when choosing protective equipment.



WARNING!

Remove your hearing protection as soon as you stop the engine, so that you can hear any noises or warning signals.

EAR PROTECTION

Ear protection offering sufficient dampening effect should be used.

EYE PROTECTION

Blows from branches, or whirling objects can lead to eye injuries.

BOOTS

Use anti-slip and stable boots.

CLOTHING

Wear clothes made of a strong fabric and avoid loose clothing that can catch on shrubs and branches. Always wear heavy, long pants. Do not wear jewelry, short pants, sandals or go barefoot. Secure hair so it is above shoulder level.

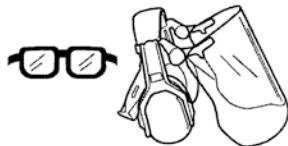

BREATHING PROTECTION

Breathing protection should be worn if there is a risk of dust.



The machine's safety equipment

This section describes the machine's safety equipment, its function and how checks and maintenance are carried out to ensure that it operates correctly. (See the chapter "What is what" to locate where this equipment is positioned on your machine.)



WARNING!

Never use a machine with defective safety equipment. Follow the inspection, maintenance and service instructions described in this section.

1. Stop switch

The stop switch should be used to stop the engine.

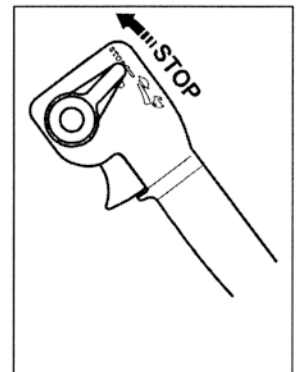

SAFETY INSTRUCTIONS

2. Vibration damping system

Your machine is equipped with a vibration damping system, which is designed to give as vibration-free and comfortable use as possible.

The machine's vibration damping system reduces the transfer of vibrations.

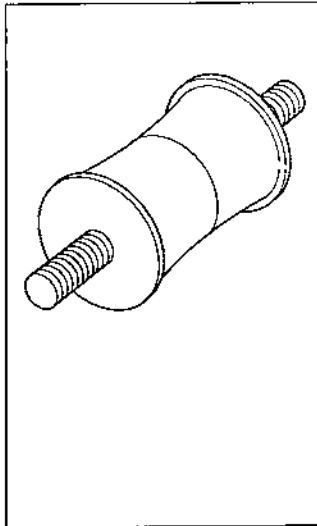

WARNING!

Over exposure to vibrations can result in blood-vessel or nerve injury to persons suffering with blood circulation problems. Seek medical attention if you experience physical symptoms that can be related to over exposure to vibrations. Examples of such symptoms are "numbness", lack of feeling, "tickling", "pricking", "pain" lack of or a reduction in normal strength, changes in the colour of the skin or its surfaces. These symptoms normally appear in the fingers, hands or wrists.

3. Muffler

The muffler is designed to give the lowest possible noise level and to direct the engine's exhaust fumes away from the operator. Muffler fitted with catalytic converter is also designed to reduce harmful exhaust components.

In countries that have a warm and dry climate the risk of fire is obvious. We have therefore fitted certain mufflers with a spark arrester screen. Make sure that your muffler is fitted with this kind of screen.

It is extremely important that the instructions for checking, maintaining and servicing the muffler are followed. (see the section "*Inspection, maintenance and service of the machine's safety equipment*").

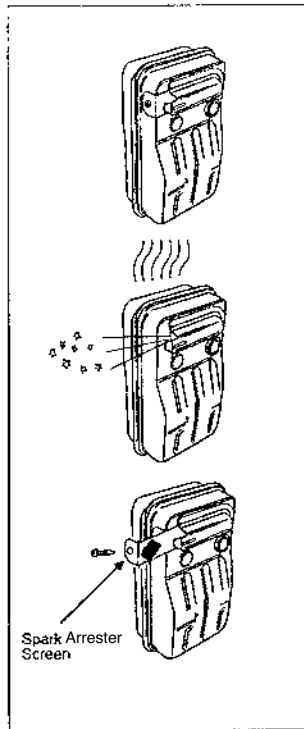

WARNING!

Bear in mind that exhaust fumes:

- contain carbon monoxide, which can cause carbon monoxide poisoning. Therefore never start or run the machine indoors.
- are hot and can contain sparks that can cause fires. Never start the machine indoors or close to flammable material.

SAFETY INSTRUCTIONS

Inspection, maintenance and service of the machine's safety equipment

IMPORTANT INFORMATION

- All service and repairs to the machine require special training.
- This applies especially to the machine's safety equipment. If the machine does not pass any of the inspections listed below you should contact your service workshop.
- The purchase of one of our products guarantees that professional repair and servicing will be carried out on it. If the point of purchase is not one of our servicing dealers, please ask for details of the closest service workshop.

1. Stop switch

- Start the engine and make sure that the engine stops when the stop switch is moved to the stop position.

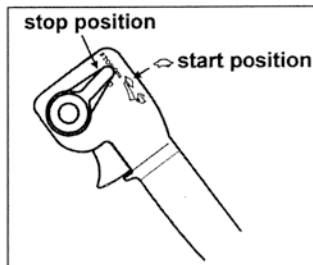

2. Vibration damping system

- Check the vibration damping element regularly for material cracks and distortion.
- Check that the vibration damping element is undamaged and securely attached.

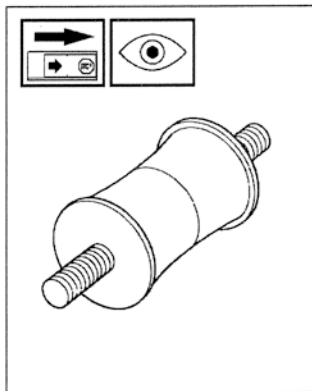

3. Muffler

1. Never use a machine that has a defective muffler.
2. Check regularly that the muffler is secure.
3. If your muffler is fitted with a spark arrester screen then it should be cleaned regularly. A blocked screen leads to the engine overheating with serious damage as a result. Never use a muffler with a defective spark arrester screen.

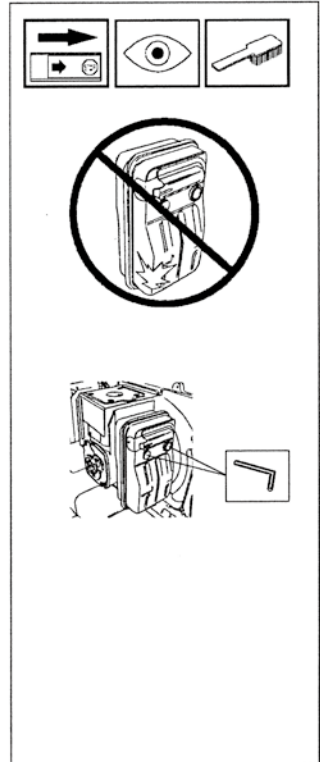

WARNING!
Never use a machine with defective safety equipment. The safety equipment should be maintained as described in this section. If your machine does not pass any of these inspections you should contact your service workshop.

SAFETY INSTRUCTIONS

General safety instructions

IMPORTANT INFORMATION

- Never use the machine if you are tired, if you have consumed alcohol, or if you are taking medicines that can affect your sight, your judgement or the control of your body.
- Use personal protective equipment. See the section "Personal protective equipment".
- Never use a machine that has been modified so that it no longer corresponds with the original design.
- Never use a machine that is faulty. Follow the maintenance, inspection and service instructions in this Handling instructions. Some maintenance and service actions should be carried out by trained and qualified specialists. See the chapter "Maintenance".
- All covers and guards must be fitted before starting the machine. Check that the spark plug cap and HT lead are not damaged, otherwise you could get an electric shock.
- The machine operator shall ensure, while working, that no persons or animals come closer than 10m (33 ft.). When several operators are working in the same area the safety distance should be at least double tree length, however, at least 10m (33 ft.).

Start

- Never start the machine indoors. Bear in mind the dangers of inhaling the engine's exhaust fumes.

Observe your surroundings and make sure that there is no risk of people or animals coming into contact with the blown air.

- Place the machine on the ground. Push the machine body towards the ground using your left hand. (NOTE! Not with your foot). Grip the starter handle with your right hand and pull the startercord.

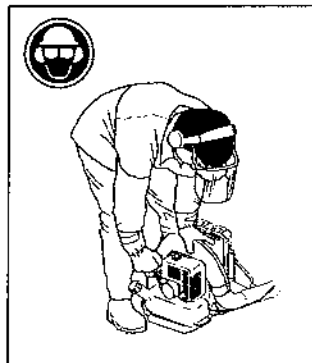

Fuel safety

- Always use a fuel container with an anti-spill valve.
- Never refuel the machine while the engine is running. Always stop the engine and let it cool for a few minutes before refueling.
- Make sure there is plenty of ventilation when refuelling or mixing fuel (petrol and 2-stroke oil).
- Avoid all skin contact with fuel. Fuel is a skin irritant and may even cause injury to the skin.
- Move the machine at least 3m (10 ft.) from the refuelling position before starting.
- Never start the machine if:
 - a) If you spill fuel on the machine. Wipe off any spillage and allow remaining fuel to evaporate.
 - b) If you spill fuel on yourself or your clothes, change your clothes. Wash any part of your body that has come in contact with fuel. Use soap and water.
 - c) If the machine is leaking fuel. Check regularly for leaks from the fuel cap and fuel supply tubing.

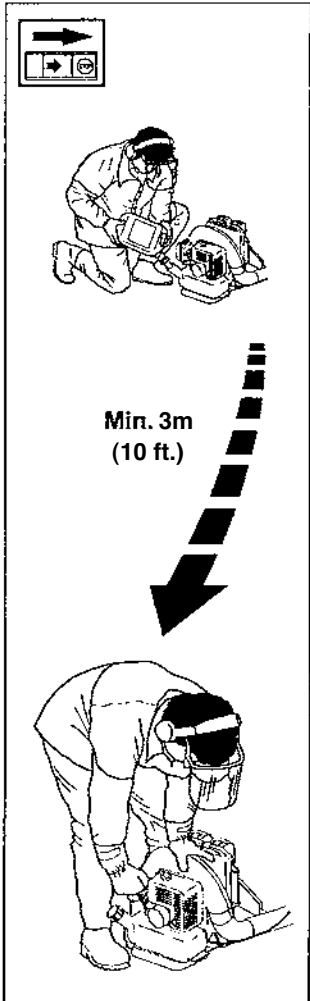

Transport and storage

- Store and transport the machine and fuel so that there is no risk of any leakage or fumes coming into contact with sparks or naked flames. For example, electric machines, electric motors, electrical switches/power switches, heaters or the like.
- When storing and transporting fuel, approved containers intended for this purpose must be used.
- When storing the machine for long periods, the fuel tank must be emptied. Contact your local petrol station to find out where to dispose of excess fuel.
- Ensure the machine is cleaned and that a complete service is carried out before long-term storage.



WARNING!

Exercise great care when handling fuel. Bear in mind the risk of fire, explosions and inhaling fumes.

SAFETY INSTRUCTIONS



WARNING!

Always use the harness when working with the machine, otherwise it will not be possible to operate it safely and this can result in injury to yourself or others. Never use a harness with a faulty quick release.

Equal load on shoulders

A well-adjusted machine and harness simplify working considerably. Adjust the harness to give the best working stance. Adjust the side straps so that the weight is equally divided across the shoulders.



General working instructions

IMPORTANT INFORMATION

- This section considers basic safety rules when working with blowers.
- If you encounter a situation where you are uncertain how to proceed you should ask an expert. Contact your dealer or your service workshop.
- Avoid all usage which you consider to be beyond your capability.

Basic safety precautions

Show consideration to persons in your surroundings by avoiding using the machine at unsuitable times, such as late in the evening or early in the morning. Read through and follow the simple directions so that you disturb your surroundings as little as possible.

- Use the blower with the lowest possible throttle. It is seldom necessary to use full throttle, and many work procedures can be done at half throttle. A lower throttle means less noise and less dust, and it is also easier to keep control over the rubbish collected together/moved.
- Use a rake or a brush to release rubbish stuck to the ground.
- Hold the opening of the blower as close to the ground as possible.
- Observe your surroundings. If anyone approaches your work area, set the throttle control to the lowest throttle until the person is at a safe distance. Direct the blower away from people, animals, play areas, and cars etc.
- Clean up afterwards. Make sure that you have not blown rubbish into someone's garden.

1. No unauthorized persons or animals may be present in the working area, which is 10m (33 ft.).
2. The powerful currents of air can move objects at such a speed that they can bounce back and cause serious eye injuries.
3. Never point the blower nozzle toward people or animals.
4. Stop the engine before fitting or dismantling accessories or other components.

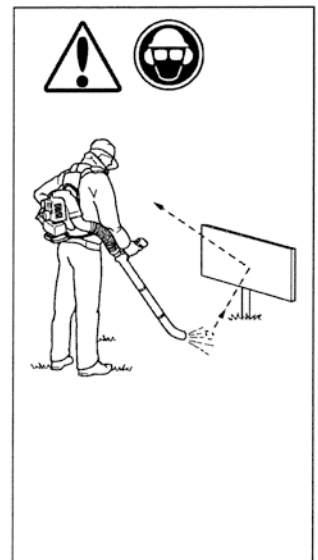

SAFETY INSTRUCTIONS

5. Never operate the blower in poorly ventilated spaces where exhaust fumes might otherwise be inhaled.
6. Do not operate the blower while standing on a ladder or a stand.
7. Avoid usage in unfavourable weather conditions. For example, thick fog, heavy rain, strong winds or extreme cold, etc. To work in bad weather conditions is tiring and can create dangerous circumstances, e.g. slippery surfaces.
8. Make sure you can walk and stand safely. Look out for any obstacles with unexpected movement (roots, stones, branches, pits, ditches, etc.). Take great care when working on sloping ground.
9. Never put the machine down with the engine running unless you have good sight of it.



Basic working techniques

- Adjust the harness so that the machine is easy to carry. See page 8, Equal load on shoulder.



WARNING!
Always stop the engine when cleaning.

- The speed of the air jet is controlled with the throttle. Select the speed that best suits the application. To avoid holding your finger on the throttle all the time when using the blower, the required throttle can be set with the throttle adjuster (D). Full throttle is obtained when the throttle adjuster is pushed in fully.
- Make sure that the air intake is not blocked by leaves or rubbish. This will reduce the machine's air blowing capacity and increase the engine's working temperature, which can lead to engine failure. Stop the engine and remove the object.
- Observe the direction of the wind. Work in the direction of the wind to simplify your work.
- Using the blower to move large heaps is time consuming and creates unnecessary noise.

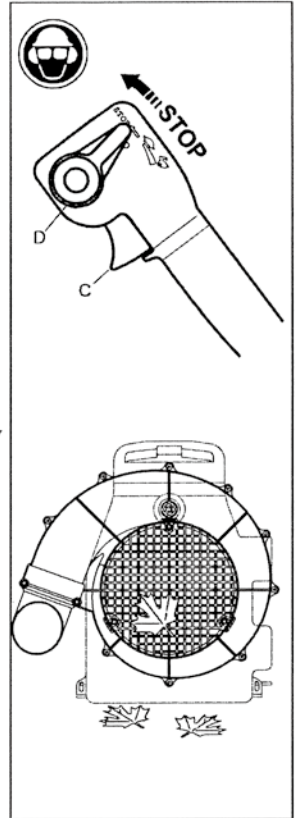

WARNING!
Warning for thrown objects. Always wear protective glasses. Stones, rubbish, etc. can be thrown up into the eyes causing blindness or serious injury. Keep unauthorised persons at a distance. Children, animals, onlookers and helpers should be kept outside the safety zone of 10m (33 ft.). Stop the machine immediately if anyone approaches.

WHAT IS WHAT?

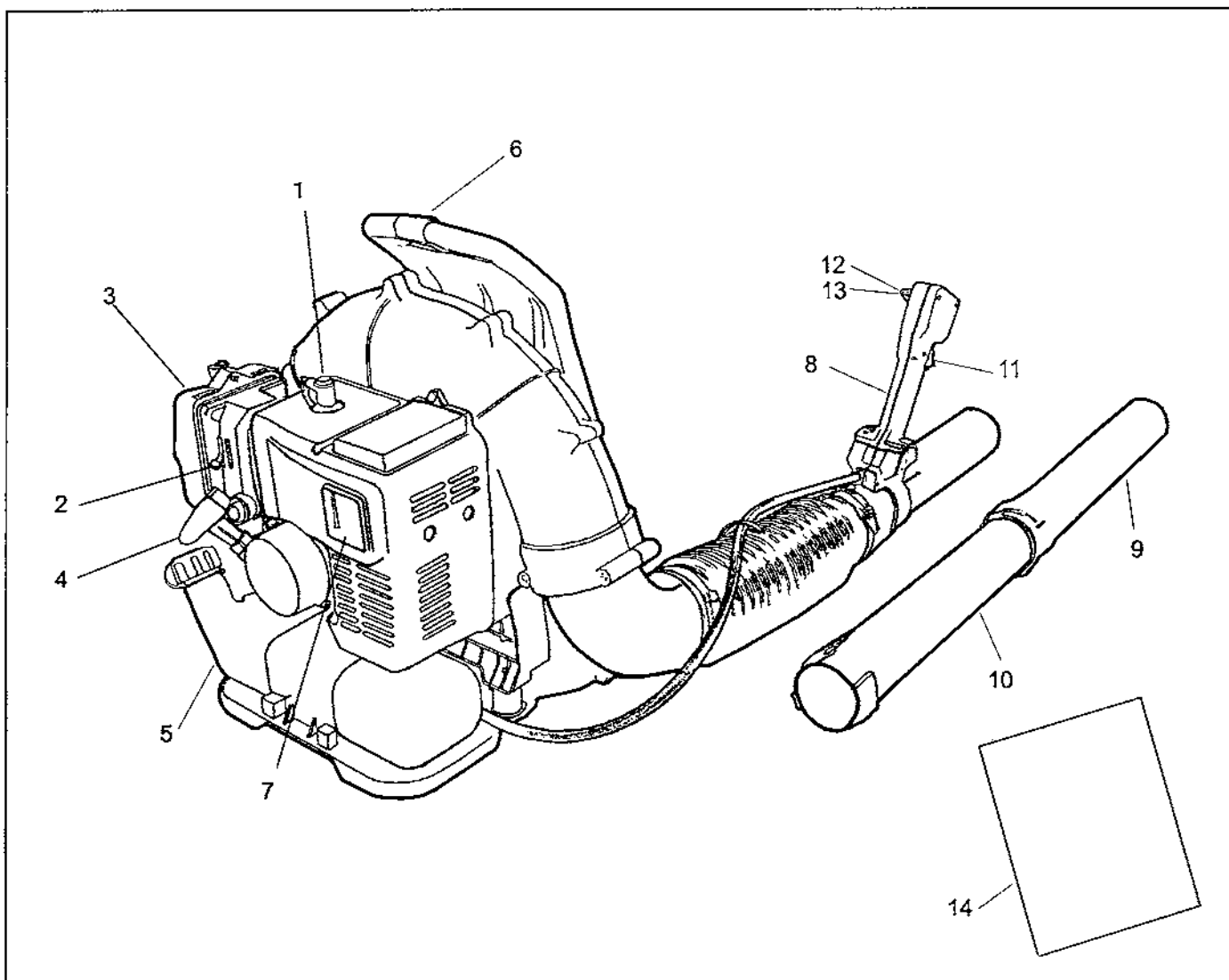

What is what on the blower?

1. Spark plug
2. Choke lever
3. Air cleaner
4. Starter handle
5. Fuel tank
6. Frame
7. Muffler
8. Handle
9. Straight pipe
10. Middle pipe
11. Throttle lever
12. Stop switch
13. Throttle adjuster
14. Handling instructions

ASSEMBLY

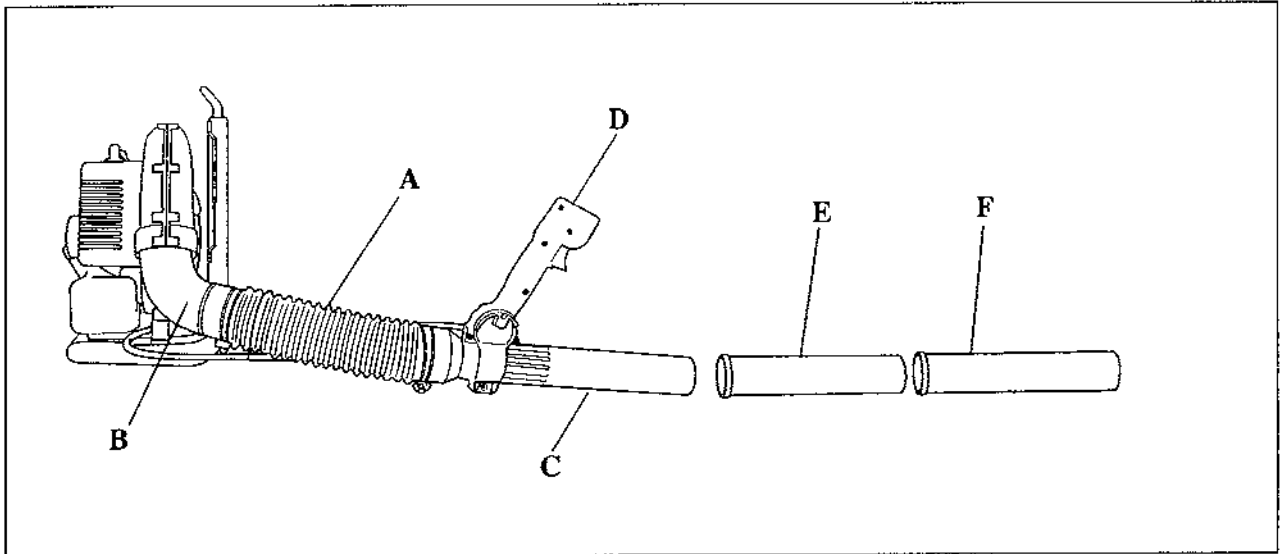

Assembly of the blower

1. Connect the flexible pipe (A) to the fan's outlet elbow pipe (B) with a hose band.
2. Fit the control handle (D) on the swivel pipe (C).
3. Connect the swivel pipe (C) to the flexible pipe with a hose band.
4. Connect the middle pipe (E) and straight pipe (F). Push the pipes together and turn them so that they lock together.

NOTE!

The swivel pipe can be turned round its axis to direct the air jet.
Dose not work with straight pipe.

FUEL HANDLING



WARNING

Taking the following precautions will lessen the risk of injury and property damage. Use extreme care in handling gasoline. Gasoline is extremely flammable and the vapors are explosive.

- Extinguish all cigarettes, cigars, pipes, and other sources of ignition.
- Use only approved gasoline container.
- Never remove gas cap or add fuel with the engine running. Allow engine to cool a minimum of 3 minutes before refueling.
- Never fuel the machine indoors.
- Never store the machine or fuel container where there is an open flame, spark, or pilot light such as on a water heater or other appliances.
- Never fill containers inside a vehicle or on a truck or trailer bed with a plastic liner. Always place containers on the ground away from your vehicle when filling.
- Remove the blower from the truck or trailer and refuel it on the ground. If this is not possible, then refuel the equipment with a portable container, rather than from a gasoline dispenser nozzle.
- Keep the nozzle in contact with the rim of the fuel tank or container opening at all times until fueling is complete. Do not use a nozzle lock-open device.
- If fuel is spilled on clothing, change clothing immediately.
- Never overfill fuel tank. Always wipe off any spilled fuel or oil. Replace fuel cap and tighten.

Fuel mixture

NOTE!

The machine is fitted with a two-stroke engine and must always be run on a mixture of gasoline and two-stroke engine oil. It is important to measure the quantity of oil accurately, to ensure the correct mixture ratio. Small discrepancies in the amount of oil have a great bearing on the proportions of the fuel mixture when mixing small amounts of fuel.



WARNING!

Always provide good ventilation when handling fuel.

Gasoline

NOTE!

Use a minimum of 87 octane gasoline purchased within 4 weeks of usage. **The engine will not operate on gasoline marketed as E-85 (85% ethanol).**

- The lowest recommended octane rating is 87. If you run the engine on a petrol with a lower octane rating than 87, "knocking" can occur. This leads to an increased engine temperature, which can result in a serious engine breakdown.
- When working at continuous high revs a higher octane rating is recommended.

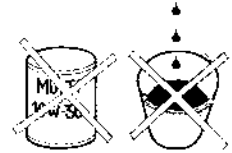
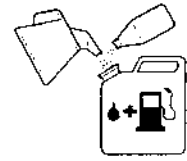

Two-stroke oil

- Use **ONLY** two-stroke oil specially formulated for air cooled small engines at a mixture of 50 : 1 (2%).
- Never use two-stroke oil intended for water cooled outboard engines, sometimes referred to as outboard oil.
- Never use oil intended of four-stroke engines.

FUEL HANDLING

Mixture

- Always mix the gasoline and oil in a clean container intended approved for gasoline.
- Always start by filling half the quantity of the gasoline required. Then add the entire oil quantity.
ADD the remaining amount of gasoline.
- Mix (shake) the fuel mixture carefully before filling in the machine's fuel tank.
- Do not mix more than max. one month's supply of fuel.
- If the machine is not used for a long period of time, the fuel tank should be emptied and cleaned.



WARNING!
The catalytic converter muffler gets very hot during and after use. This also applies during idling. Be aware of the fire hazard, especially when handling the saw near flammable substances or vapours.

Fueling



WARNING!

The following precautions reduce the risk of fire:
Do not smoke or place any sources of heat in the vicinity of the fuel. Never refuel when the engine is running. Always stop the engine and let it cool for a few minutes before refueling. Open the fuel cap slowly when fueling so that any over pressure is released slowly. Tighten the fuel cap carefully after refueling. Always move the machine from the fueling place before starting.

- Clean around the fuel cap. Contamination in the tank can cause operating problems.
- Ensure that the fuel is well mixed by shaking the container before filling the tank.

Gasolin Benzin Essence Gasolina Lit.	Oil + Öl Huile + Aceite Lit.
5	0,10
10	0,20
15	0,30
20	0,40
US gallon	US fl. oz.
	2% (50:1)
1	2,5
2,5	6,5
5	13

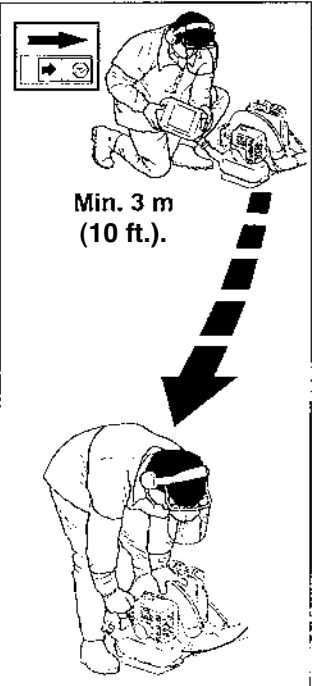

STARTING AND STOPPING

Start and stop



WARNING!
Always move the machine from the filling area before starting. Place the machine on a flat surface. Make sure no unauthorized persons are in the working area, otherwise there is a risk of serious personal injury. The safety distance is 10m.

Cold engine start

IGNITION:

Set the stop switch to the start position.

CHOKE LEVER:

Set the choke lever up to set the choke.

PRIMING PUMP:

Press the priming pump repeatedly until fuel begins to flow through the overflow tube.

Warm engine start

Use the same starting procedure as for the cold engine, but do not set the choke lever in the choke position.

NOTE!

In hot conditions the fuel can evaporate out of the carburetor after shutting off the machine. This results in hard starting even if the engine is warm. By using the priming pump the carburetor is refilled with fuel. The engine will not get flooded by using the priming pump.

Stopping

To stop the engine, always return to idle speed and allow engine to continue running at idling for a short while before moving the switch to off position.

The engine is stopped by switching off the ignition.

NOTE!

Always let the engine return to an idle speed for 10 seconds before stopping. This allows the engine to cool down gradually. This prolongs the life of some engine components.

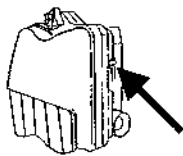
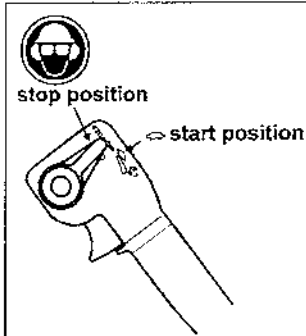

COLD ENGINE START

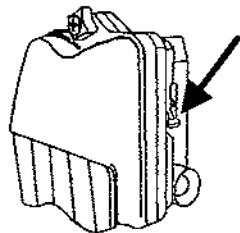
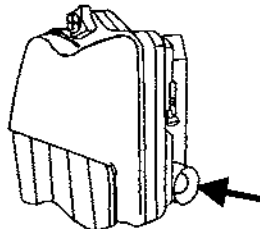

WARM ENGINE START



WARNING!

Never stop the engine by closing the choke lever.

Never stop the engine during operation (running at high or MID speed) unless returning to idle speed first.

Starting

Press the machine body against the ground using your left hand (NOTE! Not your foot). Grip the starter handle, slowly pull out the cord with your right hand until you feel some resistance (the starter pawls grip), now quickly and powerfully pull the cord. Reset the choke lever as soon as the engine fires and repeat until the engine starts.

NOTE! Do not pull the starter cord out completely and do not release the starter cord from the fully extended position. This can damage the machine.

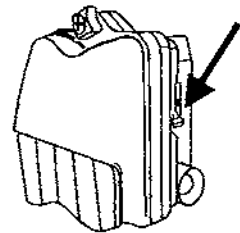

MAINTENANCE

MAINTENANCE, REPLACEMENT, OR REPAIR OF THE EMISSION CONTROL DEVICES AND SYSTEMS MAY BE PERFORMED BY ANY NONROAD ENGINE REPAIR ESTABLISHMENT OR INDIVIDUAL.



WARNING!
The machine must only be started as a complete unit. If the machine is started without all the covers fitted there is a risk of personal injury.

Conditions

- Before any adjustments are made the airfilter should be clean and the airfilter cap fitted. Adjusting the carburetor while a dirty airfilter is in use will result in a leaner mixture when the filter is finally cleaned. This can give rise to serious engine damage.

Operation

- The setting of the carburetor means that the engine is adapted to local conditions, for example, the climate, altitude, gasoline and the type of 2-stroke oil.

Maintenance and Adjustment

Periodic Maintenance Chart

▲WARNING

Accidental engine starting can cause injury. Always remove the spark plug cap before performing any service work to prevent accidental starting. When starting the blower should always be completely assembled.

Maintenance	Intervals					
	Daily	First 20 hours	Every 20 hours	Every 50 hours	Every 100 hours	Every 200 hours
Check and replenish fuel	●					
Check for fuel leakage	●					
Check for loose or missing bolts, nuts and screws	●					
Check throttle lever operation	●					
Check engine switch operation	●					
Check shoulder harness condition	●					
Clean fuel filter			●			
Clean air filter element *1					●	
Tighten bolts, nuts and screws		●		●		
Clean spark plug and adjust electrode gap				●		
Remove dust and dirt from cylinder fins					●	
Remove carbon deposits on piston head and inside cylinder *2						●
Remove carbon deposits in the muffler					●	
Clean spark arrester screen				●		
Check the sliding portion of crankshaft, connecting rod etc. *2						●
Fuel tube	It is recommended to replace every 3 years					

NOTE

○ The service intervals should be used as a guide.

(* 1) The air filter should be cleaned more frequently in very dusty conditions.

(* 2) These items require proper tools and should only be performed by an authorized dealer.

MAINTENANCE

Muffler

NOTE!

The muffler is designed to dampen the noise level and to direct the exhaust fumes away from the user. The exhaust fumes are hot and can contain sparks, which can result in fire if the exhaust fumes are directed towards a dry and flammable material. Some mufflers are equipped with a special spark arrester screen. It should be cleaned regularly. This is done using a wire brush. The screen should be cleaned weekly, or replaced if necessary.

If the screen is damaged it should be replaced.

A blocked screen can cause the engine to overheat resulting in damage to the cylinder and piston.

NOTE!

Never use a machine with a damaged muffler.

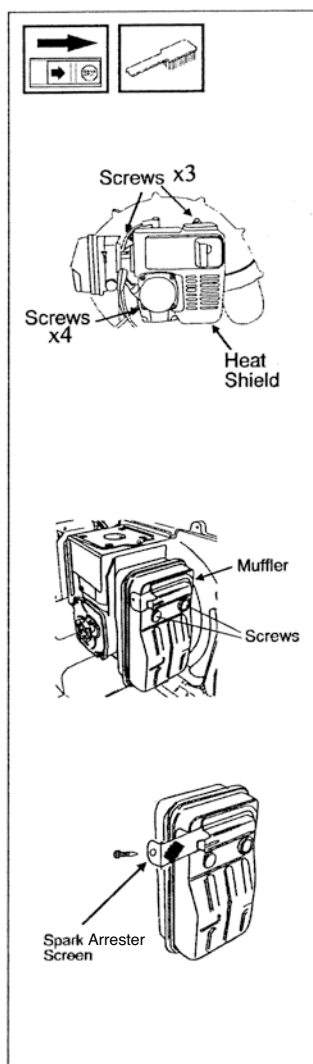

Cooling system

To maintain as low operating temperature as possible the engine is equipped with a cooling system.

The cooling system consists of:

1. An air intake on the blower housing.
2. Fins on the blower fan.
3. Cooling fins on the cylinder
4. Cylinder cover (directs cold air onto the cylinder).

Clean the cooling system using a brush at weekly in difficult conditions more often.

A dirty or blocked cooling system can cause the engine overheating, resulting in damage to the cylinder and piston.

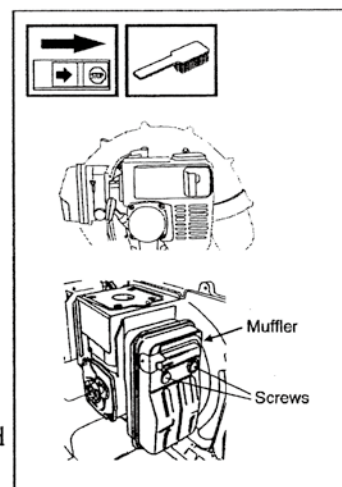

Spark plug

The condition of the spark plug is affected by:

- An incorrect carburetor setting.
- An incorrect fuel mixture (too much or faulty oil).
- A dirty air filter.

These factors cause deposits on the spark plug electrode that may result in malfunction or starting difficulties.

If the machine is low on power, difficult to start, or runs poorly while idling, always check the spark plug first.

If the spark plug is dirty, clean it and at the same time, check that the electrode gap is 0.85 mm. The spark plug should be changed after about one month of operation or earlier.

NOTE! Always use the recommended type of spark plug. An incorrect spark plug can damage the cylinder/piston.

RECOMMENDED SPARK PLUG : NGK BPMR7A-9

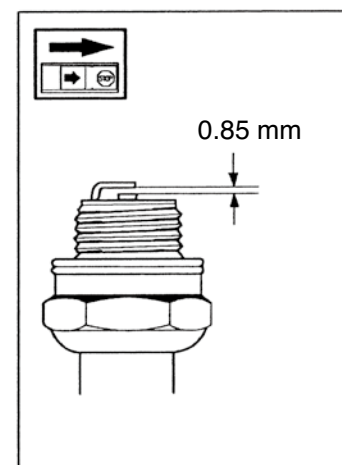

MAINTENANCE

Air filter

The air filter should be cleaned regularly removing dust and dirt to avoid:

- carburetor malfunction
- starting problems
- reduced engine power
- unnecessary wear to engine parts
- abnormal fuel consumption

Clean the filter after every 20 hours or more regularly if operating conditions are exceptionally dusty.

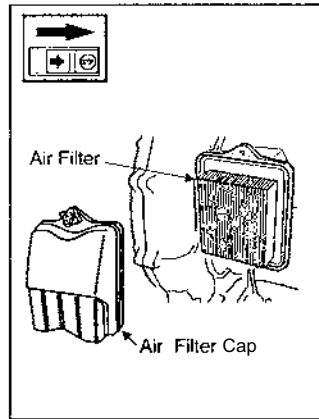

Cleaning the air filter

Dismantle the air filter cap and remove the air filter element. An air filter element used for a long period of time can never be cleaned completely. Therefore, it is necessary to replace the filter from time to time with a new filter element.

A damaged air filter must always be replaced.

Air Filter Element

Clean the element every 20 hours.

Clean the element by tapping gently to remove dust. If very dirty, replace the element with a new one.

Replace with a new element yearly 200 hours.

CAUTION

Do not wash paper-element.
Do not use pressurized air to clean or dry paper element.

NOTE

Operating in a dusty condition may require more frequent maintenance than above.

CAUTION

After servicing the air cleaner, be sure all the removed parts are reinstalled properly in place. Failure to secure fastening of the air filter cap with the two screws may cause dirt or other foreign materials to enter the engine, while it is running, through the air cleaner, resulting in engine troubles or failures.

Maintenance schedule

Below follows some general maintenance instructions. If you need further information please contact your service workshop.

Daily maintenance

1. Clean the outside of the machine.
2. Check that the throttle control functions safely.
3. Check that the stop switch functions.
4. Check that all nuts and screws are tightened.

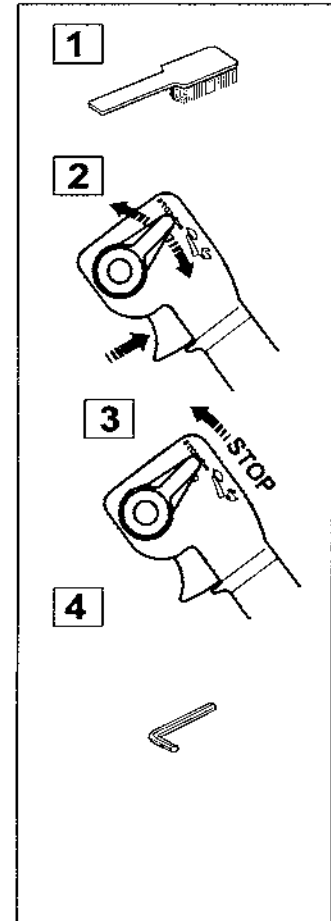

MAINTENANCE

Weekly maintenance

1. Check the starter, the starter cord and the return spring.
2. Make sure that the vibration damping elements are not damaged.
3. Clean the outside of the spark plug. Remove and check the electrode gap. Adjust the gap to 0.85 mm or change the spark plug.
4. Clean the cooling fins on the fan.
5. Clean or replace the muffler's spark arrester screen.
6. Clean the carburetor area.
7. Clean the cooling fins on the cylinder and check that the air intake in the starter unit is not blocked.

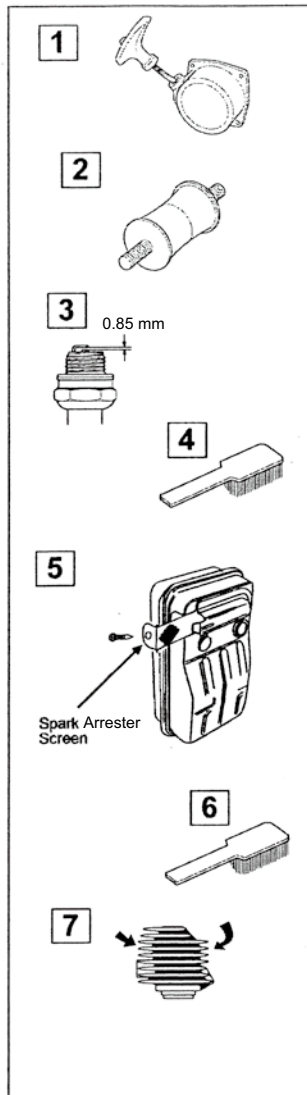

Monthly maintenance

1. Clean the fuel tank.
2. Clean the carburetor and the area surrounding it.
3. Clean the fan and the area around it.
4. Check the fuel filter and the fuel pipe, replace if necessary.
5. Check all cables and connections.

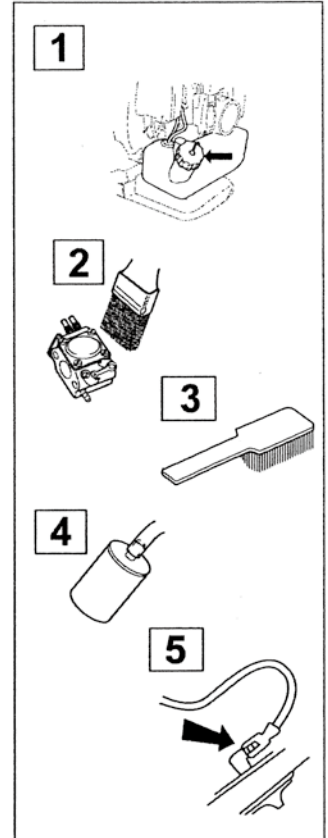

TECHNICAL DATA

Technical data

RB 65EF

Engine

Cylinder displacement, mL	64.7
Cylinder bore, mm	48.5
Stroke length, mm	35
Idling speed, min ⁻¹	2,500
Recommended max. speed, min ⁻¹	7,000
Max. engine output, acc. to ISO 8893, kW/min ⁻¹	2.9 / 8,000 (3.9HP)
Catalytic converter muffler	No

Ignition system

Manufacture/type of ignition system	CDI
Spark plug	NGK BPMR7A-9
Electrode gap, mm	0.85

Fuel lubrication system

Manufacturer/type of carburetor	Walbro, diaphragm
Fuel tank capacity, L	2.0

Weight

Weight without fuel and attachments, kg	9.9
---	-----

Noise levels

Equivalent noise pressure level at the user's ear, measured according to EN 31806 and ISO 7917, dB(A), min/max:	97
Equivalent noise power level at the user's ear, measured according to EN 31806 and ISO 10884, dB(A), min/max:	105

Vibration levels

Vibration levels on the handles, measured according to EN 31806 and	
When idling, handles, max:	1.4
At max. speed, handles, max:	2.2

 **Hitachi Koki Co., Ltd.**

006
Code No. E99006671
Printed in Japan