



MOTOROLA

User Manual

FX-853C

Dual band Wireless Local Loop Phone

(Back cover)

Motorola, the Stylized M Logo, and other Motorola trademarks and trade dress are owned by Motorola, Inc. and are used under license from Motorola, Inc. MOTOROLA and the Stylized M Logo are registered in the U.S. Patent & Trademark Office. All other products or service names are the property of their respective owners. © Motorola, Inc 2007. All rights reserved.

The information contained in the FX-853C user guide is believed to be correct at the time of printing. We reserve the right to change or modify any information, product specifications, features or functionality without notice. The contents of the FX-853C user guide are provided "as is." Certain features may not be activated by your service provider, and/or their network settings may limit the feature's functionality. Additionally, certain features may require a subscription. Contact your service provider for details.

FX-853C User Guide version 1.1 11/15/2007

© Copyright 2007, Motorola Inc., All rights reserved

USER'S GUIDE

This page is intentionally left blank

WELCOME

Congratulations on the purchase of your Motorola FX-853C product!

Please retain your original dated sales receipt for your records.

For warranty service of your Motorola FX-853C product, you will need to provide a copy of your dated sales receipt to confirm warranty status.





Thank you for choosing a Motorola product.

Please read important safety instructions before use.

Read and understand all instructions before use.

Please retain this guide for future reference.

Index

1.1. PLUGGING THE AC/DC ADAPTOR.....	10
1.2. SIM CARD	10
1.3. BATTERY	12
1.4. COMBINING BELT CLIP	13
1.5. LOCATING THE PHONE ON THE CRADLE	14
2. FEATURE HIGHLIGHTS.....	15
3. ABOUT THE PHONE	16
3.1. FX-853C PHONE	16
3.2. KEY FUNCTIONS	16
3.2.2.  <i>Send key</i>	17
3.2.3.  <i>End key</i>	17
3.2.4. <i>Numeric Keys</i>	17
3.2.5.   <i>Scroll keys</i>	17
3.2.6. <i>Using the selection keys</i>	17
3.2.7. <i>Using the scroll keys</i>	17
3.2.8.  <i>Speaker button</i>	17
3.3. DISPLAY INDICATORS AND ICONS	18
3.3.1. <i>Start screen</i>	18
3.3.2. <i>Scroll bar</i>	18
3.4. IDENTIFIERS	18
4. BASIC OPERATIONS	20
4.1. SWITCHING THE PHONE ON AND OFF	20
4.2. MAKING A CALL.....	20

4.3. ANSWERING A CALL	20
4.4. SPEAKER MODE	20
4.5. ADJUSTING THE VOLUME	21
<i>4.5.1. Adjusting the ringer volume</i>	21
<i>4.5.2. Adjusting earpiece volume</i>	21
4.6. REDIALING THE LAST-DIALED NUMBER	21
4.7. CALLER ID	22
4.8. SMS AND VOICE MAIL	22
4.9. PAGING THE PHONE BY THE CRADLE	23
5. USING PHONE MENUS	24
5.1. NAVIGATE MENUS	24
<i>5.1.1. Scrolling through menus</i>	24
<i>5.1.2. Exiting menu levels</i>	24
5.2. MENU TREE	24
6. ENTERING LETTERS AND NUMBERS	28
6.1. ENTERING LETTERS	28
<i>6.1.1. Editing name or phone number</i>	28
<i>6.1.2. Changing the case of letters and numbers</i>	29
7. USING THE PHONEBOOK	30
7.1. USING THE PHONE BOOK	30
7.2. USING PHONE BOOK MENUS	30
7.3. BROWSE (BY NAME)	31
7.4. ADDING A NEW PHONE BOOK ENTRY	31
7.5. SPEED DIAL	32
7.6 DELETE ALL ENTRIES	32

7.7 GROUP	33
7.8. COPY	33
7.9. MY NUMBER	33
7.10. MEMORY STATUS.....	34
8. SENDING AND RECEIVING TEXT MESSAGES.....	35
8.1. WRITE MESSAGE.....	36
8.2. INBOX.....	36
8.3. OUTBOX.....	37
8.4 DRAFTS	37
8.5. USING VOICEMAIL (NETWORK SERVICE).....	38
8.6. BROADCAST MESSAGE.....	38
8.7. MESSAGE SETTING.....	38
8.8. TEMPLATES.....	39
8.9 MEMORY STATUS.....	39
9. CALL RECORDS	40
9.1. CHECKING INCOMING/OUTGOING/MISSED CALL	40
9.3. CALL DURATION.....	41
10.1. PHONE SETTINGS	42
10.1.1. Clock settings	42
10.1.2. Language	43
10.1.3 Answer Mode.....	43
10.2 CALL SETUP.....	43
10.2.1. Call Divert.....	44
10.2.2. Call Barring (Network Service).....	44
10.2.3. Call waiting (Network service).....	45
10.2.4. Auto Redial.....	46

10.2.5. Caller ID.....	46
10.3. NETWORK SETUP	46
10.3.1. Network Select mode.....	46
10.4. FACTORY DEFAULT.....	47
11.1. SIM PIN	48
11.2. PHONE LOCK	48
11.3 AUTO KEY LOCK	49
11.4 CHANGE PASSWORD	49
12. TONE	50
12.1. TONE SETUP	50
12.2 VOLUME.....	50
13. DISPLAY	51
13.1 IDLE DISPLAY	51
13.1.1 Clock and Date.....	51
13.2.2 Idle Text.....	51
13.2.3 Wallpaper	51
13.2 CONTRAST	51
13.3 LCD BACKLIGHT	51
14. ACCESSORIES.....	52
14.1 ALARM.....	52
14.2. CALCULATOR	53
14.3 CALENDAR.....	54
15. TECHNICAL INFORMATION	55
15.1. SPECIFIC ABSORPTION RATE DATA	55

15.2. TECHNICAL SPECIFICATION.....	56
16. SAFETY INFORMATION.....	57
16.1 EXPOSURE TO RADIO FREQUENCY (RF) ENERGY	57
16.2 OPERATIONAL PRECAUTIONS.....	57
16.3 EXTERNAL ANTENNA CARE	57
16.4 PHONE OPERATION.....	57
16.5 DATA OPERATION	58
16.6 APPROVED ACCESSORIES.....	58
16.8 MEDICAL DEVICES	58
17. WARRANTY	61
17.1 PRODUCTS COVERED.....	61
17.2 EXCLUSIONS.....	61

1. PREPARING YOUR PHONE FOR USE

Before using your phone, the phone must be set up according to the following instructions.

1.1. Plugging the AC/DC adaptor

- Connect the adaptor to the AC Wall outlet.
- Insert the adaptor plug into the DC jack of the cradle.

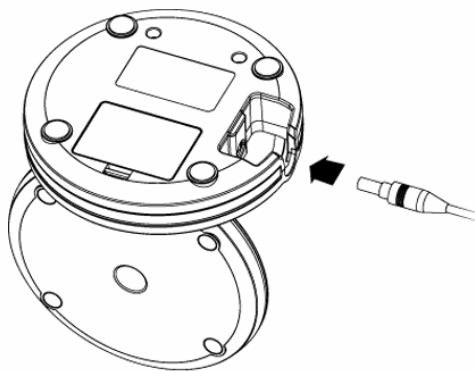

1.2. SIM Card

- Remove the battery door.
- Insert SIM card into the SIM slot in the right direction
- Replace the battery door.

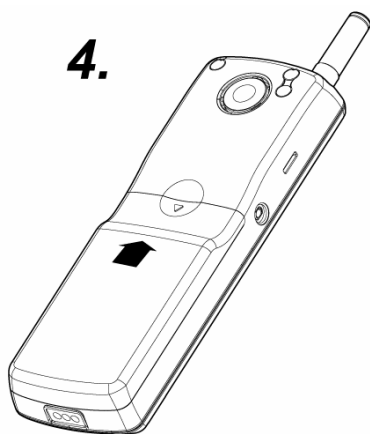
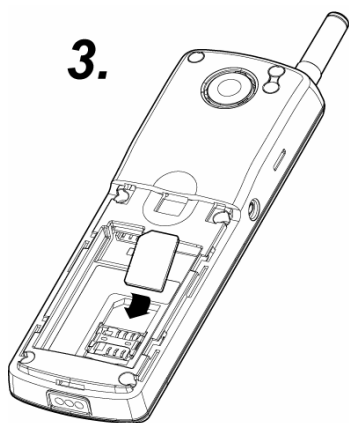
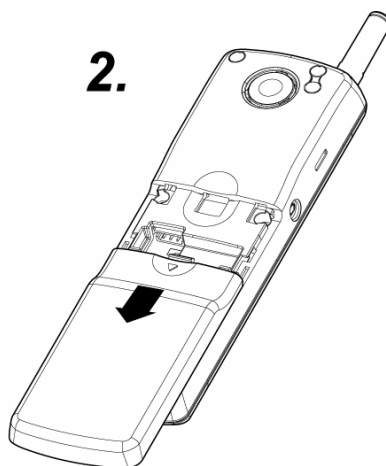
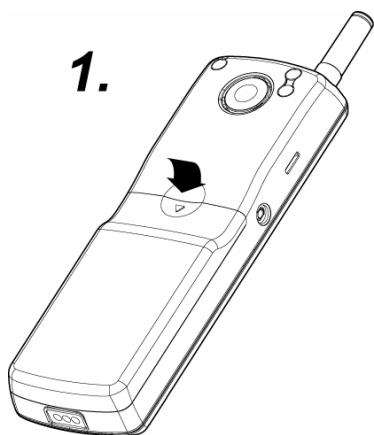

Caution:

- It is prohibited to use the SIM card for this Fixed Wireless Phone in other GSM phone. Once the SIM pin number is entered, the SIM pin is automatically changed so the initial PIN is no longer valid. Therefore, it is highly recommended

NOT to take out the SIM card once it is installed in this product.

- **DO NOT** bend or scratch your SIM card, and avoid exposing it to static electricity, water, or dirt.

1.3. Battery

- Remove the battery door.
- Connect the battery plug into the slot of the phone
- Locate the battery in the right direction
- Replace the battery door.

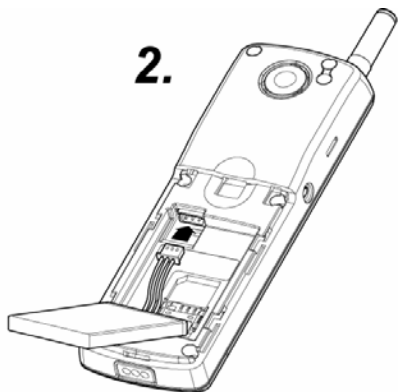
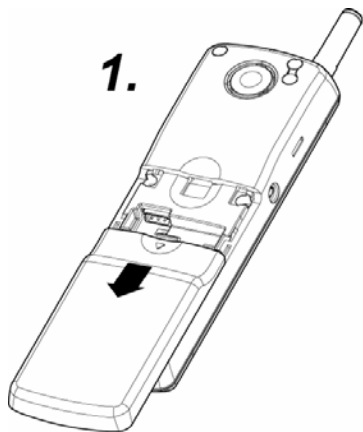

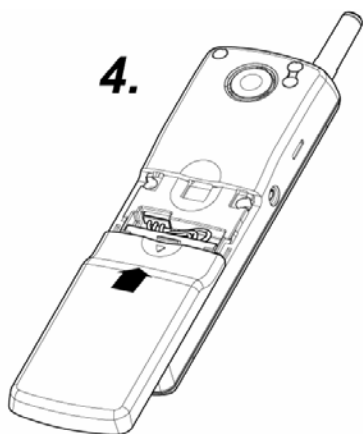
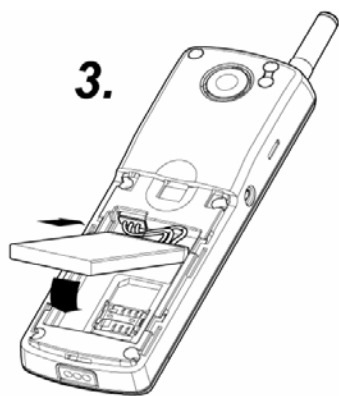

Caution:

- Be sure to carefully match the direction between plug and slot.

1.4. Combining Belt Clip

- Combine belt clip into the back of the phone until it's placed on the exact position.

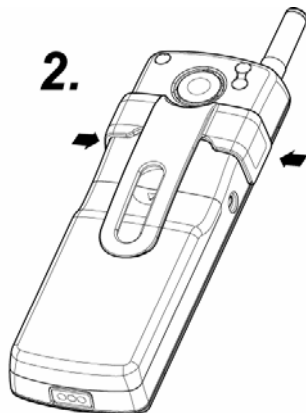
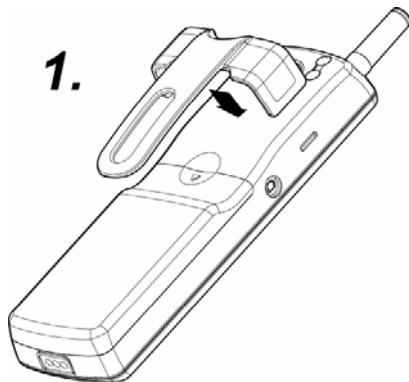

1.5. Locating the phone on the cradle

- Put the phone on the cradle to charge the phone battery.

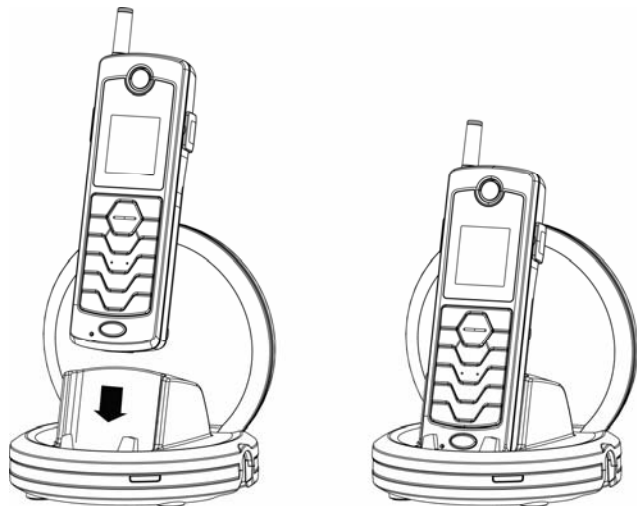

2. FEATURE HIGHLIGHTS

- Dial tone generation
- Codeless Form factor
- Auto Dialing
- Voice mail
- Short Message Service
- Emergency call
- Call logs
- Call restriction
- Caller ID
- Alarm clock
- Calculator
- Graphic color display
- Blue back light for keypad
- Multi-ring tone
- Speaker phone
- Multi-language (English, Spanish, Portuguese, It may vary by market)
- 100 Phone Book memory
- Rechargeable battery
- Belt Clip

3. ABOUT THE PHONE

This phone can operate in different bands (depending on the service provider). It supports dual band(900MHz / 1800MHz).

3.1. FX-903C Phone

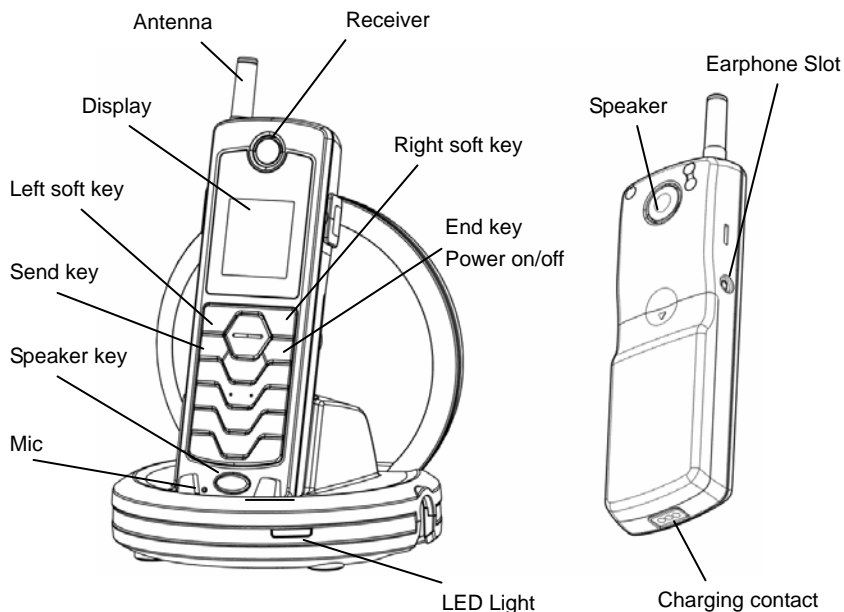

3.2. Key functions

3.2.1. Menu / Selection / Name key

- Press the left key **Menu** to perform the function indicated by the text on the screen above the key.

- Press the right key  to directly access the Phone Book list.

3.2.2. **Send key**

- Press to make a call to a name / number shown on the screen.
- Press to answer a call.
- Press and hold for 2 seconds to access the list of recently dialed numbers.

3.2.3. **End key**

- Press to end a call.
- Press once to exit a function and return to the start screen.

3.2.4. **Numeric Keys**

- Used for entering numbers and letters.
- Press and hold to call the voice mailbox.
- Press to toggle between upper case, lower case and numeric modes.
- Press to toggle between letters and symbols.

3.2.5. **Scroll keys**

- Press to go to the inbox.
- Press to go to alarm.

3.2.6. **Using the selection keys**

The functions of the selection keys depend on the guiding text shown above the keys. For example, when the text **Menu** is above the left selection key, press the left key  enters the menu functions. Similarly, pressing the right selection key under the text **Phonebook** accesses the Phone Book functions.

3.2.7. **Using the scroll keys**

The phone has two scroll keys,   located just below the screen.

The scroll keys have up and down arrows on them; press these to scroll through the phone's menus.

3.2.8. **Speaker button**

- Turn the speaker ON and OFF in conversation mode.

3.3. Display indicators and icons

The display indicators and icons provide information about the operation of the phone.

3.3.1. Start screen

The start screen is displayed when the phone is turned ON. Several features can be used only when the phone is at the start screen.

3.3.2. Scroll bar





When you access the phone's menu, there is a scroll bar at the far right of the screen. This bar indicates the user's location in the menu: each "tab" on the bar represents a different menu item.











3.4. Identifiers

On your phone, you have two types of identifiers: indicators and icons. Icons are graphic representations of a specific item or situation. For example, an icon appears when you have a voice message waiting.

Indicators show the status of something. The phone uses three types of indicators:

- Signal strength indicator: Vertical bars show the strength of the network connection. (weak)      (Strong)
- Network indicator

-  During the call
 -  Cannot make or receive calls
 -  Network forwarding
- Phone lock indicator.
 - : Phone lock
- Message indicator
 -  Text message
 -  Voice message
- Alarm indicator:  shows when the alarm is activated
- Mute indicator :  shows when the ring-tone is silent
- Battery level indicator: Vertical bars show the battery charge level.
 (Full)  (Empty)
- Ringer volume indicator: When you press , the upper key once during idle, you are able to enter the ringer volume adjustment. Scrolling up and down using the key adjusts the ringer volume higher or lower.

4. BASIC OPERATIONS

4.1. Switching the phone ON and OFF

To turn on your phone, press and hold “End key”  for a few seconds or until the display turns on. If prompted, enter your 4-digit PIN code.

Caution: If you enter an incorrect PIN code 3 times in a row, your SIM card is disabled and your display shows SIM Blocked. Contact your service provider.

To turn off your phone, press and hold “End key”  for a few seconds

4.2. Making a call

1) Enter phone number which you want to call.



2) Press “Call key”  to make a call.

Tip: In some menus like Phonebook, Message, Call log, etc. which have individual phone number, Press “Call key”  directly to make a call.

Caution: If you're too far from your home (The location where the cradle is located), the call would not be available.

4.3. Answering a call.

When your phone rings, just pick your handset up to answer, or press “Call key”

 or “Speaker key”  to answer in speaker phone mode.

4.4. Speaker mode.

You can make or answer a phone call by pressing 

To make a call:

- Press  to turn ON the speaker phone mode.
- If you hear the dial tone, press the number you want to connect to.

Note: The call is automatically made without pressing , approximately 3 seconds after you dial the number.

To answer a call:

- When the phone rings, press to turn ON the speaker phone mode.

4.5. Adjusting the Volume



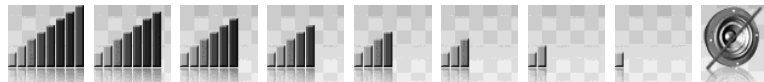

(Highest)



(Mute)



4.5.1. Adjusting the ringer volume



You can adjust the ring tone volume by pressing the scroll keys on the phone.

- 1) Press   up to enter the ring volume control screen.
- 2) Press  to increase the volume.
- 3) Press  to decrease the volume.

4.5.2. Adjusting earpiece volume



You can adjust the earpiece volume during a call by pressing the scroll keys on the phone.

- 1) Press  to increase the volume.
- 2) Press  to decrease the volume.

Note: You can also adjust the speaker volume with   when you are in speaker mode.

4.6. Redialing the last-dialed number

The phone stores up to 10 last dialed numbers. Stored numbers may be up to 20 digits long.

- 1) Press  for about two seconds to find the most recently dialed numbers.
- 2) Press volume to scroll to the number you wish to dial.
- 3) Press  once.

Note: If no recently dialed numbers are stored, you will not be able to use this function.

4.7. Caller ID

Requires a subscription to a calling plan that supports this feature. Not available in all areas. Contact your telephone service provider for availability and details.

When Caller ID is active, your phone shows the caller's phone number during an incoming call, as long as this number is a part of your service provider's wireless network.

The wireless network lets you know if it does not recognize the caller's phone number.

The wireless network will also let you know if the calling party has blocked the Caller ID feature.

If you have stored the name and number of the calling party in your Phone Book and that number is supported by the wireless network, the caller's name will also appear.

4.8. SMS and Voice Mail

Requires a subscription to a calling plan that supports this feature. Not available in all areas. Contact your telephone service provider for availability and details.

A new SMS or Voice mail arrives:

- The back light of the keypad is ON and the display shows "New Message(s)" on the screen.

4.9. Paging the phone by the cradle

You can press page button on the cradle for a while to page the phone. Paging tone will last for 15 seconds.

Note: If the phone is located too far from the cradle, paging will be not available.



5. USING PHONE MENUS

5.1. Navigate menus

A menu is a list of choices you can make. Your phone menu has 7 sub-menus. Each submenu contains options that allow you to use the Phone Book, change the ring tone, etc.

You can use menus and sub-menus in two ways: by scrolling or by using shortcuts.

5.1.1. Scrolling through menus

1) From the Start screen, press **Menu**, and then scroll through the menus using the   key.

2) Use the scroll and selection keys to navigate the submenus and to return to the Start screen.

5.1.2. Exiting menu levels

1) To return to the previous menu level, press **Back** or **Cancel**.

2) To return to the Start screen, press . No menu setting changes will be saved.

5.2. Menu Tree

Your phone's menu may differ from the following list, depending on the network services to which you have subscribed and the accessories you are using. If you have any questions, please call your service provider.

1. Phone Book	
	1. Browse
	2. Create
	3. Speed Dial
	4. Delete All Entries
	1. Delete All ME Entries

	2. Delete All SIM Entries
	5. Group
	1. Family
	2. Friends
	3. Office
	4. Others
	6. Service Dialing Number
	7. Fixed Dialing Number
	1. Enable FDN
	2. Browse
	8. Settings
	1. Memory in Use
	2. Copy
	3. My Number
	9. Memory Status
2. Message	
	1. Write Message
	2. Inbox
	3. Outbox
	4. Drafts
	5. Voice Mail
	1. Number
	2. Delete
	3. Connect to Voice Mail
	6. Broadcast Message
	1. Receive Mode
	2. Languages
	7. Message Settings
	1. Service Center Number
	2. Expire Period
	3. Masseur Type
	4. Status Report
	5. Alert Period
	8. Template
	9. Memory Status
3. Call Log	
	1. Incoming Call

	2. Outgoing Call
	3. Missed Call
	4. Call Duration
4. Settings	
	1. Phone Settings
	1. Clock Settings
	2. Language
	3. Answer Mode
	2. Call Setup
	1. Call Divert
	2. Call Barring
	3. Call Waiting
	4. Auto Redial
	5. Caller ID
	3. Network Setup
	4. Factory Default
5. Security Setup	
	1. SIM PIN
	2. Phone Lock
	3. Auto Key Lock
	4. Change Password
6. Tone	
	1. Tone Setup
	1. Incoming Call
	2. Message Tone
	2. Volume
	1. Call
	2. Ring Tone
	3. Keypad Tone
7. Display	
	1. Idle Display
	1. Clock and Date
	2. Idle Text
	3. Wallpaper
	2. Contrast
	3. LCD Backlight
8. Accessories	

	1. Alarm
	2. Calculator
	3. Calendar
9. SIM Tool Kit	

6. ENTERING LETTERS AND NUMBERS

You can enter letters, as well as numbers, when storing information in your phone by using your phone's keypad. To enter letters, press the key associated with the letter you wish to enter until it appears on the screen (numbers will also appear).

6.1. Entering Letters

When you want to add new names or when you view names in the Phone Book, your phone automatically switches to "abc" mode and displays "abc" icon.



Key Characters Key Characters

Key	Characters	Key	Characters
1	, . ? ! @ 1	7	p q r s 7 ß \$
2	a b c 2 â æ ä à ç á	8	t u v 8 ù ü ú
3	d e f 3 è é	9	w x y z 9
4	g h i 4 ì í	0	(Space) 0
5	j k l 5 £	*	, . ' ? ! " @ ¥ \$ _ ' ~ { } [] ? # ¤ % & () * + - / : ; < = > \$ ¿
6	m n o 6 ö ø ò ñ ó	#	Change letter case(*)

* : abc → Abc → ABC → 123 rotated

6.1.1. Editing name or phone number

To edit a name already stored in the Phone Book:

- From the main screen, use the right soft key.
- From the Phone Book list, select the name you want to edit.
- To edit, press the left soft key and scroll down to the edit option.
- Select the name or the phone number you want to change.
- Press the left soft key  to enter edit mode.
- Press  to scroll the cursor to the left.

- Press  to scroll the cursor to the right.
- Press **Delete** to correct any mistakes.
- Press the left soft key **OK** to save changes or the right soft key to cancel.

6.1.2. Changing the case of letters and numbers

You can switch the mode among uppercase and lowercase letters and numbers by pressing # key.

7. USING THE PHONEBOOK

7.1. Using the Phone Book

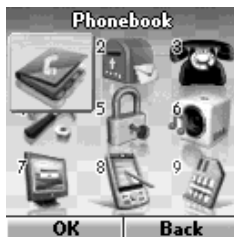

New entries can be stored in the SIM card or in your handset.

You can store up to 100 entries in the phone and an additional 100 in the SIM depending on the SIM limitations.

Entries stored in the phone allow numbers of up to 30 digits, and names of up to 16 characters.

In idle mode, you can press right  **Phonebook** to immediately access the Phone Book list. 

When the number is found by pressing **Phonebook**, you can select it and choose to view, edit delete, copy, move or send message.

7.2. Using Phone Book menus

The Phone Book has several menus to select from. These menus appear when you press **Phonebook** or enter from main menu. Press right  move back to the main menu.

- **Browse:** Browse name you selected.
- **Create:** Create new entry(s)
- **Speed Dial:** One button dialing
- **Group:** Organizing group of phone book
- **SDN:** Service Dialing Number

- **FDN:** Fixed Dialing Number
- **Settings:** Copy phonebook entries and check the memory usage and my number
- **Delete All Entries:** Delete all Phone or SIM entries
- **Memory Status:** Memory status of phone and SIM

7.3. Browse (by name)

From the Phonebook menu, select Browse and press **OK** or just press 1.

Enter the first letters of the name you need and the cursor goes to the name you wanted directly after two seconds.

Select name using to scroll and press left  **option** to select menu. then you can choose five sub menus

7.3.1 Send Message To: You can send SMS to this entry

7.3.2 View: You can see the name and number of this entry

7.3.3 Delete: You can delete this entry only(You need to re-confirm)





7.3.4 Add to group: You can put this entry to group(See 7.8 'Group'), but you cannot use SIM entry to a group.

7.3.5 Copy: If you select a SIM card's entry and select **Copy**, you can copy it to phone memory. If your selection is Phone memory's entry, **Copy** means copy chosen entry to SIM card

7.4. Adding a new Phone Book Entry

To create a Phone Book entry:

- 1) Press **Menu > Phone Book >** Scroll to **Create** and press **OK**
- 2) Press **Save To SIM** or **Save To Phone** depending on where you want to store the phone entry.
- 3) Select 'Name', Press left  **Option** and choose **Edit**.
- 4) Enter Name

- 5) Press left  **Option** and select **Accept** to complete input.
- 6) Select 'Number', Press left  **Option** and choose **Edit**.
- 7) Enter Number
- 8) Press left  **Option** and select **Accept** to complete input.
- 9) Press left  **Option** and choose **Save**.

7.5. Speed Dial

- 1) Press **Menu > Phone Book**.
- 2) Scroll to **Speed Dial** and press **OK**
- 3) Select one entry. If the numbers are **Empty**, Press **OK**. Select **Set/Change**, you can assign one phone number. After choosing one, press **OK**
- 4) If you assigned one phone number already, you can see four sub categories
 - Set/Changes: You can change the assigned number
 - Detail: You can see the number of this entry
 - Delete: You can delete this entry
 - Dial to: You can dial to this entry

You can assign the speed dial only with phone entries (No SIM entries)

You can assign the speed dial up to 8 entries.

On the idle display, press one assigned button and press Call  button

Ex> If the number assigned in 2 is 123-456-7890, just press **2** and 

7.6 Delete All Entries

You can delete all Phone Book entries:

- 1) Press **Menu > Phone Book**
- 2) Scroll to **Delete all Entries** and press **OK**
- 3) Press **Delete All Phone Entries** or **Delete All SIM Entries**, depending

on where you want to delete all Phone Book entries.

- 4) Press **OK** to confirm the deletion of all Phone Book entries.
- 5) Select Yes if you want to delete. Otherwise, select No to go back to the previous menu.

Caution: When complete all information stored in your Phone Book will be deleted and can no longer be restored.

7.7 Group

: You can see four groups 1) Family 2) Friends 3) Office 4) Others

: Select one and press left  **OK** and you can see the sub menus

: In one group, you can select three sub menus

7.7.1 Group Member: You can see and edit entry(s) belonging to the group

7.7.2 Rename: You can edit the name of this group itself (Ex> Family → Home)

7.7.3 Alert Tone: You can change the tone when the member of this group called you.

7.8. Copy

You can use this function to copy numbers from the SIM card to your phone, or vice versa

- 1) Press **Menu > Phone Book. > Settings.**
- 2) Scroll to **Copy** and press **OK**
- 3) Press **From SIM card to phone** or **From Phone to SIM Card** depending on where you want to copy all Phone Book entries.

Press OK then the copy process is done promptly

7.9. My Number

You can check, edit, erase and save your owner number

- 1) Press **Menu > Phone Book > Settings**

- 2) Scroll to **My number** and press **OK**.

7.10. Memory Status

To press 'Memory Status' and you can see the status of phonebook memory in SIM card and phone.

8. SENDING AND RECEIVING TEXT MESSAGES



You can send or receive text messages with your phone. It supports 160 characters and you can insert Use Template (already 10 sentences are recorded in your phone) to shorten the editing time.

You can also send maximum 480 characters. If your message is 480 characters, the phone divides your message into three parts(160 + 160 +160) and send these in each time. This function is called SMS concatenation.

After completing the message content, you can choose to send it out right away, or save it as a draft.

Note: The maximum length of a text message differs, depending on the capabilities of the network from which it originated. Also, text messages may appear different at different times because messages can originate in networks other than your own. Contact your service provider for more information about this feature.

1. Write Message
2. Inbox
3. Outbox
4. Draftbox
5. Voice Mail
6. Broadcast Message
7. Message Settings

8. Template
9. Memory Status

8.1. Write Message

You can send a text message to one or several recipients. You can manually enter each recipient's phone number, or you can select numbers from the Phone Book.

- 1) Press **Menu > Short Messages**.
- 2) Scroll to **Write Message** and press **OK**
- 3) You can create the message.
- 4) When you press **OK**, you can see three submenus;
 - **Only Send:** After sending, the message is deleted
 - **Only save:** No sending. The message is saved into **Drafts**.
 - **Send and Save:** After sending the message is saved into **Outbox**

8.2. Inbox

When a message arrives, a pop-up message is displayed and a new message icon appears. You can read it immediately, or read it later in your Inbox. You can see the new message icon  in the idle display

- 1) Press Menu > **Short Messages**.
- 2) Scroll to the **Inbox** and press **OK**.
- 3) From the list, scroll to the one you want to read and press **OK**.
- 4) You can choose four options
 - **Reply:** You can reply a message to the number you got from.
 - **Forward:** You can send the chosen message to another number.
 - **Edit:** You can edit the chosen message.
 - **Delete:** You can delete the chosen message.

- **Delete all:** You can empty the Inbox.
- **Cut Number:** It will help you find numbers in the message to save in the phonebook

Note: After the SMS memory in the SIM card is full, the phone starts using the memory in the phone.

8.3. Outbox

The Outbox stores messages sent and saved.

- 5) Press Menu > **Short Messages**.
- 6) Scroll to the **Outbox** and press **OK**.
- 7) From the list, highlight the one you need and press **OK**.
- 8) You can choose four options
 - **Send:** You can send a message to the number you sent.
 - **Forward:** You can send the chosen message to another number.
 - **Edit:** You can edit the chosen message.
 - **Delete:** You can delete the chosen message.
 - **Delete all:** You can empty the Outbox.
 - **Cut Number:** It will help you find numbers in the message to save in the phonebook

8.4 Drafts

: You can see draft messages which you already saved. After choosing one of them, you can have five choices

- **Forward:** You can send the chosen message.
- **Edit:** You can edit the chosen message.
- **Delete:** You can delete the chosen one.

- **Delete All:** You can empty the draft box.

8.5. Using Voicemail (Network Service)

You can listen to your voicemail messages by calling your network voicemail phone number. Voicemail messages are stored in the network voicemail box, not in your phone.

- 1) Press **MENU > Short Messages**.
- 2) Scroll to **Voice Mail** and press **OK**.
- 3) There are three submenus. Select one and press **OK**
 - **Number:** Enter or modify the network service number.
 - **Delete:** Delete Pre-saved service number
 - **Connect to Voice Mail:** Dial the network service number and connect to the Voicemail Server.

8.6. Broadcast Message

There are 2 submenus you can choose

- 1) Receive Mode
- 2) Languages

8.7. Message Setting

There are 5 submenus you can choose

- 1) **Service Center Number:** The SMS Center Number is required in order to send messages. Ask your service provider for this number.
- 2) **Expire Period:** Set the period of time the message is stored in the service center. You can set the period for 1 hour, 12 hours, 1 day, 1 week, maximum. When the set period expires, the service center will delete all messages, even if the user has not received the message.
- 3) **Message Type:** When you set the message type, the network will

convert the message to the type you have set. (Text//Fax//E-mail)

- 4) **Status Report:** If you turn On this option, you can be notified if the recipient read your message.
- 5) **Alert Period:** you can choose one time // Every 2 min // Off

8.8. Templates

You can see ten (10) pre-saved texts.

- I'm busy now. I will call you later
- How are you?
- How about Lunch?
- I'm sorry!
- Long time, no see!
- I arrived safely
- Happy Birthday
- Happy New Year!
- Thank you!
- I will be there soon!

You can select left  **Option (Edit/Forward)**

- Edit: You can modify pre-saved texts
- Forward: You can send selected text to others

8.9 Memory Status

You can check memory status for the received message in SIM card and Phone.

The total capacity of SIM is 20, total capacity of phone is 100. Also you can see used area of SIM and phone.

9. CALL Records



The Call History function keeps track of:

- Incoming Call
- Outgoing Call
- Missed Call
- Call Duration

Note: Your phone can store up to 30 call numbers including missed, received and dialed calls.

When you miss a call(s), the Missed Calls icon appears on your phone's screen. You can press Read to view the Missed Calls list or press Back to ignore the message and go back to Idle. The records will be stored in Call History.

You are notified of missed calls only when your phone is turned ON in the service area from which the missed call originated.

9.1. Checking Incoming/Outgoing/Missed Call

- 1) Press **Menu** > **Call Records**
- 2) Select Incoming // Outgoing // Missed Call and press **OK**
- 3) From the list of records, select the one you need and press **OK**
- 4) The screen shows Call Information including Number, Date and Time of receiving.
- 5) You can see six different menus
 - **Dial To:** When you choose one entry and select **OK**, directly calls

to.

- **Send Message To:** You can send this entry the SMS message without selecting recipient.
- **Delete:** You can delete chosen entry
- **Save Number:** You can save chosen number to SIM or Phone.
- **Delete all:** You can delete all entries in the category (If you select **Outgoing call** all the **Outgoing call** entries are deleted)
- **Show Number:** You can see the number of chosen entry

Note: In the idle display, the missed call icon indicates if there are unread missed call records.

Caution: Note that this action cannot be undone once you perform it. All the stored information in your log will be deleted.

9.3. Call Duration

: You can check the total duration of incoming call and last call duration

: You can see **Outgoing Duration**, **Incoming Duration** and **Last Call Duration** in one display.

: The type of checking time is hh:mm:ss (h: Hours, m: Minute, s: Second)

: You can press left  **Reset** to erase all call duration time.

10. SETTINGS



Setting menu includes:

- Phone Settings
- Call Setup
- Network Setup
- Factory Default

10.1. Phone Settings

10.1.1. Clock settings

10.1.1.1 This menu guides you to set Time/Date.

- Date & Time Setting the correct time and date to ensure the Alarm is working correctly.
- Setting Date / Time:
 - 1) Press Menu > **Settings**
 - 2) Press Phone Settings and press **OK**.
 - 3) Select Clock Settings then press **OK**.
 - 4) Select Date & Time setting and press **OK**.
 - 5) Input day/month/year by using numeric keys and press **option**
 - 6) Select **Time setting** and input hour/minute
 - 7) Press option and select **Save**

10.1.1.2. Date Display Format: There are four types of expressions of dates

- DD/MM/YY(day/month/last two digits of this year)

- MM/DD/YY
- DD/MM/YYYY (day/month/full digits of this year)
- MM/DD/YYYY

10.1.1.3 Date Separator: There are four types of separators of date digits

- OO-OO-OO (Hyphen)
- OO/OO/OO (Slash)
- OO.OO.OO (Dot)
- OO OO OO (Blank)



10.1.1.4 Time Display Format: You can choose 12h or 24 hours. For example, if the time is 1:22 pm(12h expression) , it can be shown as 13:22 (24h expression)

10.1.2. Language

Three languages can be selected: English / Spanish / Portuguese. You may also choose automatic option which change as SIM card.

- 1) Press **Menu > Settings**
- 2) Press **Phone Settings** and press **OK**
- 3) Select **Language** and then press **OK**
- 4) Select the language you need and press **OK**

10.1.3 Answer Mode

- Normal answer: When call incomes, you have to press answer key  to call
- Any key answer: To answer your receiving call, you can press any key except End key 

10.2 Call Setup

The following features may require a subscription to a calling plan that supports them.

Not available in all areas. Contact your telephone service provider for availability and details

10.2.1. Call Divert

Call Divert is a network or subscription dependent service. It allows you to forward a call to another number, based on various conditions.

- 1) Press **Menu > Settings**
- 2) Press Call Setup and press **OK**
- 3) Press Call Divert and press **OK**
- 4) Select one of the options below, and then press **OK**
 - All Voice Calls Divert: All incoming calls to a designated number.
 - On Busy: Divert all incoming calls when there is at least one call in progress.
 - No Answer: Divert the incoming call if it is not answered
 - Unreachable: Divert all incoming calls when the phone is not reachable due to a network error or some other reason.
- 5) Select Check Status, Activate, or Deactivate and press **OK**
 - Check Status: Check current Call Divert setting status.
 - Activate: Activate the chosen Call Divert option. Type the number you want a call to be forwarded to.
 - Deactivate: Deactivate the chosen Call Divert option.

10.2.2. Call Barring (Network Service)

Call Barring is a network or subscription dependent service.

This feature allows you to restrict or bar certain or all types of calls to and from your phone.

- 1) Press **Menu > Settings**

- 2) Press **Call Setup** and press **OK**
- 3) Press **Call Barring** and press **OK**
- 4) Select one of the options below, and then press **OK**
 - **All Outgoing Calls:** Bar all outgoing calls.
 - **All Int'l Calls:** Bar all outgoing international calls.
 - **Int'l Except to Home:** Prevent users from making any international calls other than to home
 - **All Incoming Calls:** All Calls Bar all incoming calls.
 - **Incoming While Roaming:** Bar all incoming calls when the phone is roaming.
- 5) Select Activate, Deactivate or Query Status, and press **OK**
 - **Check Status:** Check current Call Barring setting status.
 - **Activate:** the chosen Call Barring option.
 - **Deactivate:** the chosen Call Barring option.

Note: To activate and deactivate Outgoing, Incoming, and Cancel Calls, the SIM password is required. Contact your cellular phone provider.

10.2.3. Call waiting (Network service)

Call Waiting is a network or subscription dependent service.

If set to Activate, the Call Waiting feature enables the network to remind you of other incoming calls during a call in progress.

- 1) Press **Menu > Settings**
- 2) Press Call Setup and press **OK**
- 3) Press Call Waiting and press **OK**
- 4) Select Activate, Deactivate or check, and then press **OK**
 - **Active:** Activate Call Waiting function.
 - **Deactivate:** Call Waiting function.
 - **Check Status:** Check current Call Waiting setting status.

10.2.4. Auto Redial

Setting the Auto Redial to ON enable the phone to keep dialing if the called party is not available.

- 1) Press **Menu > Settings**
- 2) Press **Call Setup** and press **OK**
- 3) Press **Auto Redial** and press **OK**
- 4) Toggle ON or OFF, and then press **OK**

10.2.5. Caller ID

Caller ID is a network or subscription dependent service.

You can choose to send/hide your phone number to/from the calling party.

- 1) Press **Menu > Settings**
- 2) Press **Call Setup** and press **OK**
- 3) Press **Caller ID** and press **OK**
- 4) Toggle Set by Network, Hide Number or Show Number and then
- 5) press **OK**
 - **Set By Network:** Accepts the default value set by Network.
 - **Hide Number:** Does not show your phone number to the calling party.
 - **Show Number:** Shows your phone number to the calling party.

10.3. Network Setup

10.3.1. Network Select mode

You can set the phone to automatically search the most suitable network to camp on or to manually select the network you need.

- 1) Press **Menu > Settings**.

- 2) Press **Network Setup** and press **OK**
- 3) Press **Network select mode** and press **OK**
- 4) Select Automatic selection or Manual selection and then press **OK**
 - Manual mode: The phone starts searching available networks. Use the up and down key to browse the network list, and press OK to set the highlighted network.

10.4. Factory Default

This feature resets the current settings to the factory default values.

- 1) Press **Menu > Settings**
- 2) Press **Call Setup** and press **OK**
- 3) Enter the 4-digit password and press **OK**

Note: The default password is “0000”

11. Security



Security menu includes:

- SIM PIN
- Phone Lock
- Auto Key Lock
- Change Password

11.1. SIM PIN

You can set the lock your phone by Personal Identification Number(PIN) of your SIM card. You can also change PIN1 and PIN2 from here

- 1) Press **Menu > Settings**
- 2) Press **Security Set Up** and press **OK**
- 3) Press **SIM PIN** and press **OK**
 - PIN Check: Every time you must enter password when power on
 - Change PIN1, Change PIN2: When you change SIM card, you enter the password

11.2. Phone Lock

The default password is "0000".

- 4) Press **Menu > Settings**
- 5) Press **Security Set Up** and press **OK**

- 6) Press **Phone Lock** and press **OK**
- 7) When 'On' is chosen, there are two options.
 - Verify when Power-on: Every time you must enter password when power on
 - Verify with new SIM: When you change SIM card, you enter the password

11.3 Auto Key Lock

This feature allows you to lock the keypad to avoid being pressing without intention.

- 1) Press **Menu > Settings**
- 2) Press **Security Setup** and press **OK**
- 3) Press **Auto Key Lock** and press **OK**
 - Off : You can turn key lock function off
 - 5 Sec./10 Sec./30 Sec./60 Sec. : You can turn key lock function on by selecting time. Key lock will be activated after passing the selected time in the idle display.

11.4 Change Password

This feature allows you to change the password.

- 4) Press **Menu > Settings**
- 5) Press **Security Setup** and press **OK**
- 6) Press **Change Password** and press **OK**
- 7) You need to input three times. Old password, the new password and confirmation. Every time you enter the input, press **OK**

12. Tone



12.1. Tone setup

Set tones for Incoming Call and Message Tone.

12.2 Volume

Eight volume levels are available for Call, ring tone and keypad tone. Adjust the volume to your preference.

13. Display



13.1 Idle Display

13.1.1 Clock and Date

When you choose **Enable**, you can see the date and clock on your idle display



13.2.2 Idle Text

When you choose **Enable**, you input your own text which will be shown on the idle display.

13.2.3 Wallpaper

You can select your favorite wallpaper which will be displayed in the idle screen.

13.2 Contrast

There are 21 levels for LCD contrast. Press  then the contrast goes up.
Press  then the contrast is down

13.3 LCD Backlight

Set Specific LCD and Keypad Backlight time.

- 1) Select **LCD Backlight** and press **OK**
- 2) Toggle Always off, 5 sec, 15 sec, 30 sec or 45 sec and press **OK**

14. Accessories





Accessories includes:

- Alarm
- Calculator
- Calendar

14.1 Alarm



When alarm is set, the icon appears on the idle screen.

- 1) Press **Menu** > **Accessories** and press **OK**
- 2) Select **Alarm** and press **OK**
- 3) Select Alarm 1, 2 or 3 and Press **OK**
- 4) Press **Edit** to select four cases. Off//One time // Mon~Fri // Everyday. Select your favorite and Press **OK**
- 5) press  to set the time and press **Edit** to input time.
- 6) set the time with number keys and Press **OK**
- 7) press  and press **Edit** to select alarm ring.

- 8) Select alarm rings and press **OK**
- 9) Press **Save** to save the alarm setting

14.2. Calculator

You can calculate 9 digits.

Key description:

+, -, /, x : Use up and down arrow keys to select.

Back: Press once to clear one digit.

- 1) Press **Menu** > **Accessories** and press **OK**
 - 2) Select **Alarm** and press **OK**
- Enter the first value by number keys

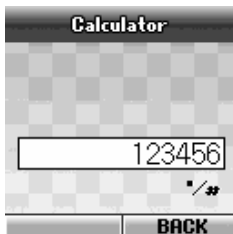

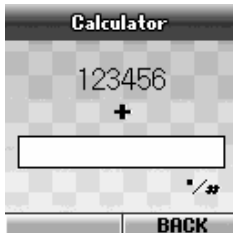

- Select the calculating mark by the upper/lower navigation key

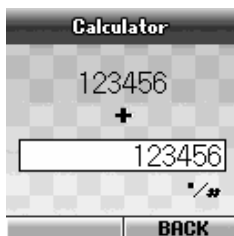

The calculating mark will toggle among **+**, **-**, **×**, **÷**

- Enter the second value by number keys



- Press left  to display the result of calculation. And you can continue the next calculation from step3.

Note: You can input decimal point “.” by pressing “#” key.

14.3 Calendar

You can change the month by Navigation key  .

- 1) Press **Menu** > **Accessories** and press **OK**
- 2) Select **Calendar** and press **OK**



15. TECHNICAL INFORMATION

15.1. Specific Absorption Rate Data

THIS DEVICE MEETS INTERNATIONAL GUIDELINES FOR EXPOSURE TO RADIO WAVES

Your mobile device is a radio transmitter and receiver. It is designed and manufactured not to exceed the limits for exposure to radio frequency (RF) recommended by international guidelines (ICNIRP). These limits are part of comprehensive guidelines and establish permitted levels of RF energy for the general population. The guidelines were developed by independent scientific organizations through periodic and thorough evaluation of scientific studies. The guidelines include a substantial safety margin designed to assure the safety of all persons, regardless of age and health.

The exposure standard for mobile devices employs a unit of measurement known as the Specific Absorption Rate, or SAR. The SAR limit stated in the international guidelines is 1.6 watts/kilogram (W/kg)*. Tests for SAR are conducted using standard operating positions with the device transmitting at its highest certified power level in all tested frequency bands.

Although the SAR is determined at the highest certified power level, the actual SAR of the device while operating can be well below the maximum value. This is because the device is designed to operate at multiple power levels so as to use only the power required to reach the network. In general, the closer you are to a base station, the lower the power output of the device.

SAR values may vary depending on national reporting and testing requirements and the network band. Use of device accessories and enhancements may result in different SAR values.

* The SAR limit for mobile devices used by the public is 1.6 W/kg averaged over 1 grams of body tissue. The guidelines incorporate a substantial margin of safety to give additional protection for the public and to account for any variations in measurements. SAR values may vary depending on national reporting requirements and the network band.

15.2. Technical Specification

Display	65K C-STN 128x128 resolution
Size	152x49x21mm for handset, 125x125x133mm for cradle
Wireless Network	GSM 850 & 1900
Frequency Range	824 ~849 MHz & 1850 ~1910 MHz
Battery	Rechargeable Ni-MH 500mAh battery pack
Backup Battery	Rechargeable Ni-MH 350mAh battery pack

16. SAFETY INFORMATION

SAFETY INFORMATION FOR FIXED PHONES

IMPORTANT INFORMATION ON SAFE AND EFFICIENT OPERATION.

READ THIS INFORMATION BEFORE USING YOUR PHONE.

16.1 EXPOSURE TO RADIO FREQUENCY (RF) ENERGY

Your phone contains a transmitter and a receiver. When it is ON, it receives and also sends out radio frequency (RF) signals. When you communicate with your phone, the system handling your call controls the power level at which your phone transmits.

Your Motorola phone is designed to comply with local regulatory requirements in your country concerning exposure of human beings to RF energy.

16.2 OPERATIONAL PRECAUTIONS

To assure optimal phone performance and make sure human exposure to RF energy is within the guidelines set forth in the relevant standards; always adhere to the following procedures.

16.3 EXTERNAL ANTENNA CARE

Use only the supplied Motorola approved antenna. Unauthorized antennas, modifications, or attachments could damage the phone.

Do NOT hold the antenna when the phone is IN USE. Holding the antenna affects call quality and may cause the phone to operate at a higher power level than needed. In addition, use of unauthorized antennas may result in non-compliance with the local regulatory requirements in your country.

16.4 PHONE OPERATION

When placing or receiving a phone call, hold your phone as you would a wireless

telephone.

16.5 DATA OPERATION

When using any data feature of the phone, with or without an accessory cable, position the phone antenna at least 8 inches (20 centimeters) from your body.

16.6 APPROVED ACCESSORIES

Use of accessories not approved by Motorola, including but not limited to batteries and antennas, may cause your phone to exceed RF energy exposure guidelines.

16.7 RF ENERGY INTERFERENCE / COMPATIBILITIES

Note: Nearly every electronic device is susceptible to RF energy interference from external sources if inadequately shielded, designed, or otherwise configured for RF energy compatibility. In some circumstances your phone may cause interference.

16.8 MEDICAL DEVICES

Pacemakers

Pacemaker manufacturers recommend that a minimum separation of 8 inches (20centimeters) be maintained between the fixed wireless phone and a pacemaker.

Persons with pacemakers should:

- Always keep the phone more than 8 inches (20 centimeters) from your pacemaker when the phone is turned ON.
- Turn OFF the phone immediately if you have any reason to suspect that interference is taking place.

Hearing Aids

Some digital wireless phones may interfere with some hearing aids. In the event of such interference, you may want to consult your hearing aid manufacturer to discuss alternatives.



Other Medical Devices

If you use any other personal medical device, consult the manufacturer of your device to determine if it is adequately shielded from RF energy. Your physician may be able to assist you in obtaining this information.

BATTERIES

Batteries can cause property damage and / or bodily injury such as burns if a conductive material such as jewelry, keys, or beaded chains touches exposed terminals. The conductive material may complete an electrical circuit (short circuit) and become quite hot. Exercise care in handling any charged battery, particularly when placing it inside a pocket, purse or other container with metal objects. Use only original batteries and chargers.

Your battery or phone may contain symbols, defined as follows.

	Your battery or phone may require recycling in accordance with local laws. Contact your local regulatory authorities for more information.
	Your battery or phone should not be thrown in the trash

Please don't use any damaged battery or charger and use the battery only for its intended purpose.

Don't apply extreme shock to the battery. It's dangerous to disassemble a battery or to apply extreme shock to the battery via nail or heavy metal objects.

Keep the charger or batteries out of reach of small children or babies. Please

instruct children the proper ways of handling phone during usage.

Shock circuit and breakdown may occur and cause severe danger to user due to improper usage.

Always try to keep the battery between -10 ~ 55 Celsius.

Use only manufacturer approved rechargeable batteries and charger designated for this device

Seizures / Blackouts

Some people may be susceptible to epileptic seizures or blackouts when exposed to flashing lights, such as when watching television or playing video games. These seizures or blackouts may occur even if a person never had a previous seizure or blackout.

If you experienced seizures or blackouts, or if you have a family history of such occurrences, please consult with your doctor.

17. WARRANTY

Limited Warranty for Personal Communication Products, Accessories and Software. What Does this Warranty Cover? Subject to the exclusions contained below, BRIGHTSTAR warrants the Motorola branded FX-903C that it manufactures ("Products"), to be free from defects in materials and workmanship under normal consumer usage for the period(s) outlined below. This limited warranty is a consumer's exclusive remedy, and applies as follows to new Motorola branded Products manufactured by BRIGHTSTAR, and purchased by consumers around the world, which are accompanied by this written warranty:

17.1 PRODUCTS COVERED

A. **Products** as defined above.

1. The Fixed Wireless Telephone.
2. The accessories included with the Fixed Wireless Telephone.

LENGTH OF COVERAGE

A. One (1) year from the date of purchase by the original consumer/purchaser of the product.

17.2 EXCLUSIONS

Batteries. Only batteries whose fully charged capacity falls below 80% of their rated capacity and batteries that leak are covered by this limited warranty.

Abuse & Misuse. Defects or damage that results from: (a) improper operation, storage, misuse or abuse, accident or neglect, such as physical damage (cracks, scratches, etc.) to the surface of the product resulting from misuse; (b) contact with liquid, water, rain, extreme humidity or heavy perspiration, sand, dirt or the like,

extreme heat, or food; (c) use of the Product for commercial purposes or subjecting the Product to abnormal usage or conditions; or (d) other acts which are not the fault of BRIGHTSTAR, are excluded from coverage.

Use of Non-Motorola branded Products and Accessories. Defects or damage that results from the use of non-Motorola branded or certified Products, Accessories, Software or other peripheral equipment are excluded from coverage.

Unauthorized Service or Modification. Defects or damages resulting from service, testing, adjustment, installation, maintenance, alteration, or modification in any way by someone other than BRIGHTSTAR or its authorized service centers are excluded from coverage.

Altered Products. Products or Accessories with (a) serial numbers or date tags that have been removed altered or obliterated; (b) brOKen seals or those that show evidence of tampering; (c) mismatched board serial numbers; or (d) nonconforming or non-Motorola branded housings, or parts, are excluded from coverage.

Communication Services. Defects, damages, or the failure of products, due to any communication service or signal you may subscribe to or use with the Products is excluded from coverage.

Who is covered? This warranty extends only to the first consumer/purchaser, and is not transferable.

What will BRIGHTSTAR Do? BRIGHTSTAR, at its option, will at no charge repair, replace or refund the purchase price of any Product that does not conform to this warranty. We may use functionally equivalent reconditioned / refurbished / pre-

owned or new Products, Accessories or parts. No data, software or applications added to your Product, Accessory or Software, including but not limited to personal contacts, games and ringer tones, will be reinstalled. To avoid losing such data, software and applications please create a back up prior to requesting service.

How to Obtain Warranty Service or Other Information

For information on how to obtain service, contact the place where the product was purchased or a BRIGHTSTAR Service Center in your country.

In order for this Warranty to take effect, take your unit, along with this policy, to the place of purchase or to a BRIGHTSTAR Authorized Service Center.

You will receive instructions on how to ship the Products, at your expense, to a BRIGHTSTAR Authorized Repair Center. To obtain service, you must include: (a) a copy of your receipt, bill of sale or other comparable proof of purchase; (b) a written description of the problem; (c) the name of your service provider, if applicable; (d) the name and location of the installation facility (if applicable) and, most importantly; (e) your address and telephone number.

18. FCC Notice To Users

We have not approved any changes or modifications to this device by the user. Any changes or modifications could void the user's authority to operate the equipment. See 47 CFR Sec. 15.19(3).

This device complies with part 15 of the FCC Rules. Operation is subject to the following two conditions : (1) This device may not cause harmful interference, and : (2) this device must accept any interference received, including interference that may cause undesired operation.

19. Information to User

This equipment has been tested and found to comply with the limits for a Class B digital device, Pursuant to part 15 of the FCC Rules. These limits are designed to provide reasonable protection against harmful interference in a residential installation.

This equipment generates, uses and can radiate radio Frequency energy and, if not installed and used in accordance with the instructions, may cause harmful interference to radio communications. However, there is no guarantee that interference will not occur in a particular installation. If this equipment does cause harmful interference to radio or television reception, which can be determined by turning the equipment off and on, the user is encouraged to try to correct the interference by one or more of the following measures:

- Reorient or relocate the receiving antenna.**
- Increase the separation between the equipment and receiver**
- Connect the equipment into an outlet on a circuit different from that to which the receiver is connected.**

Consult the dealer or an experienced radio/TV technician for help.

20. Trouble shooting

Before contacting the after-sales service, perform the following simple checks. They may save you the time and expense of an unnecessary service call.

When you switch your phone on, the following messages appear

Insert SIM Card

- Check that the SIM card is correctly installed. (Try opposite direction)

Phone Locked

- The automatic locking function has been enabled. You must enter the phone's password before you can use the phone.

Enter PIN

- You are using your phone for the first time. You must enter the Personal Identification Number supplied with the SIM card.
- The option requiring that the PIN be entered each time the phone is switched on has been enabled. You must enter your PIN and then disable this option if so required.

Enter PUK

- The PIN code was entered wrongly three times in succession and the phone is now blocked. Enter the PUK supplied by your network operator.

“No service” is displayed

- The network connection was lost. You may be in a weak reception area (in a tunnel or surrounded by buildings). Move and try again.
- You are trying to access an option for which you have not taken out a subscription with your service provider. Contact the service provider for further details.
- You are trying to use the phone too far from where your cradle is located.

You have entered a number but it was not dialed

- Have you pressed ?
- Are you accessing the right cellular network?
- You may have set an outgoing call barring option.

Your correspondent cannot reach you

- Is your phone switched on (pressed for more than one second)?
- Are you accessing the right cellular network?
- You may have set an incoming call barring option.

Your correspondent cannot hear you speaking

- Have you switched off the microphone (appears)?
- Are you holding the phone close enough to your mouth? The microphone is located in the bottom center of the phone.

The phone starts beeping and “ Warning ** Battery Low” flashes in the display**

- The battery is insufficiently charged. Replace the battery with a charged one and recharge it or connect the battery charger.

The audio quality of the call is poor

- Check the signal strength indicator in the display. The number of bars after it indicates the

Signal strength from strong to weak.

- Try moving the phone slightly or moving closer to a window if you are in a building.

No number is dialed when you recall a phonebook entry

- Check that the numbers have been stored correctly, by using the Phonebook Search feature.
- Re-store them, if necessary.

Access Codes

There are several access codes that are used by your phone and its SIM card. These codes help you protect the phone against unauthorized use.

The access codes (except for the PUK codes) can be changed using the Security Settings menu options.

Phone Password

The phone password can be set to avoid unauthorized use of the phone. The password generally supplied with the phone is 0000. You are advised to change it before you start using your phone.

Keep the new password secret and in a safe place, separate from the phone.

PIN

The PIN (Personal Identification Number) protects your SIM card against unauthorized use. The PIN is usually supplied with the SIM card. When the PIN Check feature is enabled, the PIN is needed each time the phone is switched on.

If you key in an incorrect PIN three times in succession, key in the PUK and press the OK soft key.

Key in a new PIN and press the OK soft key. Key in the new PIN again and press the OK soft key.

PUK

The PUK (Personal Unblocking Key) is required to change a blocked PIN. The PUK may be supplied with the SIM card. If not, contact your local service provider.

If you key in an incorrect PUK ten times in succession, the SIM card cannot be used anymore.

Contact your service provider for a new card.

You cannot change the PUK. If you lose it, contact your service provider.