

CUSTOMER SERVICE

The answers to most setup and performance questions can be found in the Troubleshooting guide. You can also consult the FAQs in the customer support section of our Web site at www.alteclansing.com. If you live in North America and still can't find the information you need, please call our customer service team for assistance before returning the speakers to your retailer under their return policy.

Tel: 800-258-3288

Email: csupport@alteclansing.com



If you live outside of North America, please visit our website at www.alteclansing.com and select your region to locate your country's distributor.

For the most up-to-date information, be sure to check our Web site at www.alteclansing.com.

ALTEC LANSING TECHNOLOGIES, INC.

CORPORATE HEADQUARTERS – 535 Rte. 6 & 209, Millford, PA 18337-0277
800-ALTEC-88, 570-296-4434 • Fax 570-296-6887

EUROPE – 13 Rue Beaumont, L-1219 Luxembourg, Luxembourg
Tel: +352 26 15 76 36 • Fax: +352 26 15 76 26

ASIA/PACIFIC – 25 Canton Road, Tsui Sha Tsui Kowloon, Hong Kong
(852) 2735-7331 • Fax (852) 2730-7748

© 2005 Altec Lansing Technologies, Inc. ALTEC, ALTEC LANSING, the Altec Lansing logo, the swirl design, the Altec Lansing Powered Audio Logo, Just listen to this!, inMotion, and the inMotion logo are registered trademarks or trademarks of Altec Lansing. iPod is a trademark of Apple Computer, Inc., registered in the U.S. and other countries.

The Bluetooth wordmark and logos are owned by the Bluetooth SIG, Inc. and any use of such marks by Altec Lansing is under license.

All other trademarks appearing herein are the property of their respective owners.

ALTEC LANSING®



inMotion™

BM402 MAN R04

ALTEC LANSING®

inMotion™

Wireless

Mobile

Headset

for your iPod

and Bluetooth®-enabled

cell phone

IM412

USER GUIDE

WEARING YOUR INMOTION MOBILE HEADSET

Mobile Headset for your iPod mini and Bluetooth®-enabled cell phone

BOX CONTENTS

- Stereo headset receiver
- iPod mini transmitter
- Ear buds
- Charger
- Carry case
- Lanyard
- User's guide

GETTING STARTED

To use your InMotion mobile headset for iPod mini and Bluetooth-enabled cell phone, please follow these simple steps:

1. Charge both the headset receiver and the iPod mini transmitter
2. Plug your ear buds into your headset receiver
3. Pair your headset receiver with a Bluetooth-enabled cell phone

Note: The iPod mini transmitter and the headset receiver are already paired.

4. Connect your iPod mini transmitter to an iPod mini

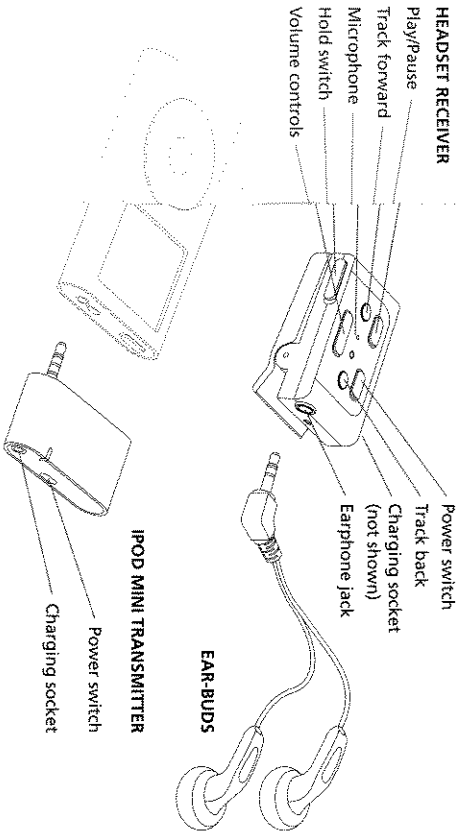
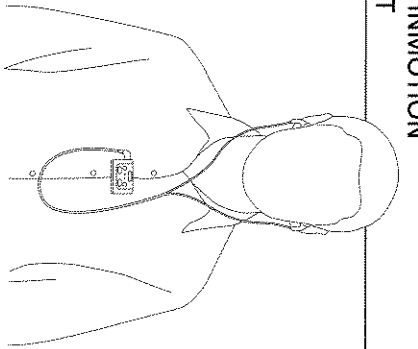

CHARGING YOUR HEADSET RECEIVER AND IPOD MINI TRANSMITTER

Both the headset receiver and iPod mini transmitter come with built-in rechargeable batteries. Prior to using the headset receiver for the first time, it is recommended to fully charge both batteries.

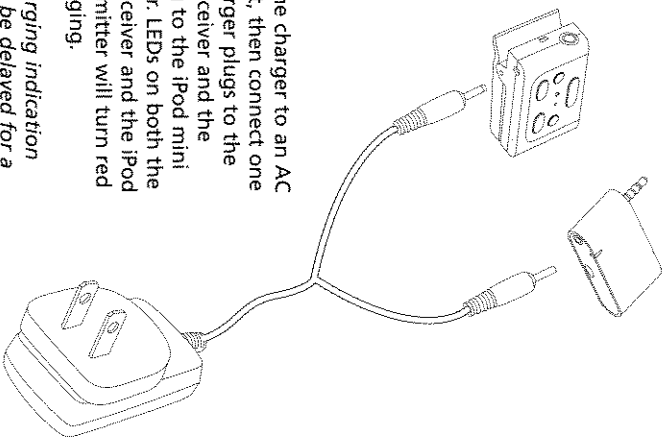

Connect the charger to an AC wall outlet, then connect one of the charger plugs to the headset receiver and the other plug to the iPod mini transmitter. LEDs on both the headset receiver and the iPod mini transmitter will turn red while charging.

Note: Charging indication will be delayed for a few minutes if the inMotion mobile headset has not been used for a long time or if the batteries are drained.

4

Nominal charging time:

A full battery charge is usually completed within 3 hours. When the batteries are fully charged, the LEDs will turn blue and remain on. Disconnect the charger from the AC wall outlet as well as the headset receiver and iPod mini transmitter.

Talk standby and stereo playback time

The fully charged batteries offer up to 5 hours of talk time, up to 125 hours of standby time, and up to 5 hours of stereo playback time. When no calls are in progress, the inMotion mobile headset remains ON in standby mode.

Batteries are low

When the inMotion mobile headset is ON and the batteries are low, the LEDs flash red. When this occurs, please recharge the batteries as described above.

5

TURNING YOUR INMOTION MOBILE HEADSET ON AND OFF

Turning the iPod mini transmitter on and off

To turn the iPod mini transmitter on, press and hold the iPod mini transmitter's power button until the LED flashes blue. To turn it off, press and hold the power button until the LED turns red and the unit turns off.

Turning the headset receiver on and off

To turn the headset receiver on, press and hold the headset receiver's power button for two seconds until the ear-buds emit a short beep and the LED flashes blue. To turn it off, press and hold the power button for 3 seconds until the ear-buds emit a long beep and the LED stops flashing.

Note: Press the headset receiver's power button again each time you turn on the headset receiver to reactivate pairing and resume the connection between the headset receiver and the Bluetooth-enabled cell phone and iPod mini. For pairing, please refer to "Pairing your headset receiver."

Preventing false commands while on the go

Slide the headset receiver's "hold" switch to the right to lock out all button commands. Slide the switch to the left to restore access to all button commands.

6

MAKING CONNECTIONS

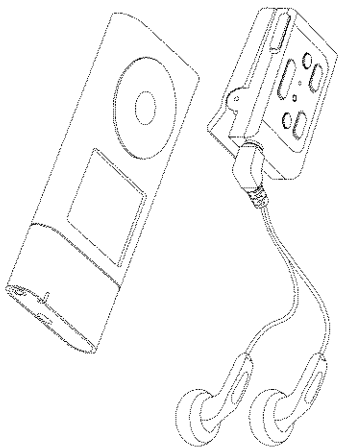

PAIRING YOUR HEADSET RECEIVER WITH YOUR BLUETOOTH-ENABLED CELL PHONE

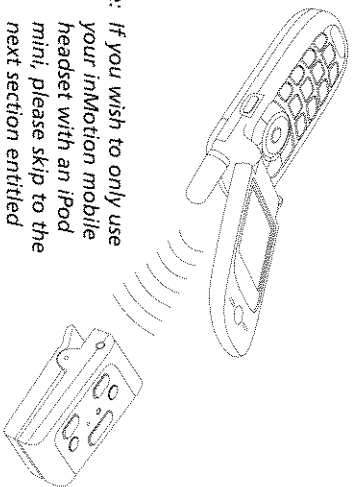

Note: If you wish to only use your InMotion mobile headset with an iPod mini, please skip to the next section entitled "Pairing your headset with your Bluetooth-enabled iPod mini."

7

Prior to using your headset receiver with your Bluetooth-enabled cell phone for the first time, the headset receiver must be paired with the cell phone. Cell phone pairing procedure will vary for each cell phone.

1. Place the headset receiver and the cell phone no more than 1 meter apart and ensure there is nothing in between.
 2. Ensure the headset receiver is turned OFF.
 3. Press and hold the headset receiver's power button until the headset receiver LED alternately flashes blue and red.
 4. Activate your cell phone's Bluetooth function. For instructions, refer to your cell phone user's guide.
 5. Set the cell phone to search for Bluetooth devices within 1 meter (consult cell phone user's guide for specific instructions) and select "iMotion Headset" from the list.
 6. Enter the preprogrammed passkey "8888" and press "OK" to pair your headset receiver and cell phone. When the pairing is completed, the headset receiver LED will flash blue rapidly 5 times and the ear-buds will emit a long beep.
 7. Press "Return" to go back to your cell phone's main menu. For certain cell phone models, a headset icon will be shown on the screen. You should now be able to make and receive calls using your headset receiver.
- Note: If the pairing cannot be completed within two minutes, the headset receiver LED will flash purple and the ear-buds will emit three beeps. The headset receiver should be turned off and the above pairing procedure repeated.*

PAIRING YOUR HEADSET WITH THE BLUETOOTH-ENABLED IPOD MINI TRANSMITTER

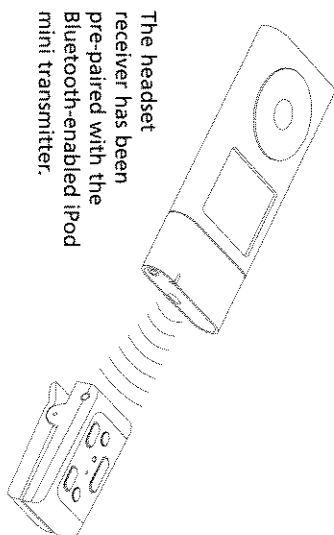

The headset receiver has been pre-paired with the Bluetooth-enabled iPod mini transmitter.

REMOVING THE CELL PHONE PAIRING

- You may want to reset the headset receiver to its original settings. This action will also clear pairing between your headset receiver and cell phone.
1. Ensure the headset receiver is turned OFF.
 2. Press and hold the center of the Volume Key for 8 seconds until you hear 2 beeps.

The headset receiver is now turned off and returns to the original settings. The pairing between your headset receiver and cell phone has been cleared. The pairing between the headset receiver and iPod mini transmitter will not be affected.

START PLAYING

1. Turn on your iPod mini
2. Turn on the iPod mini transmitter by pressing the power button.
3. Turn on the headset receiver by pressing the power button. A blue LED will turn on.

Note: To avoid hearing a popping sound when turning on your headset receiver, always turn on your iPod mini first.

WIRELESS CONTROLS

Volume control

The "+" and "-" buttons on the headset receiver control the master volume. Press and hold the "+" button to increase the volume and the "-" button to decrease the volume.

iPod mini functions

When an iPod mini is connected to the iPod mini transmitter and paired to the headset receiver, some iPod mini functions can be controlled using the headset receiver.

Note: The headset receiver will provide song navigation functions only with an iPod mini running iPod software version 2.1 or later.

1. **Play/Pause Function:** Press the Play/Pause button once to start playing the selected song. Press the Play/Pause button again to pause the song.



2. **On/Off Function:** Press and hold the Play/Pause button to turn the iPod mini off. Press any button on the headset receiver to turn the iPod mini back on.



3. **Track Forward / Track Back Function:** Press the Track Forward button to skip to the beginning of the next song.



Press and hold the Track Forward button to fast-forward through the song.



Press the Track Back button to skip to the beginning of the song currently being played.



Press and hold the Track Back button to rewind the song.



USING YOUR HEADSET RECEIVER

Answering a call

When there is an incoming call, a ringing tone will be heard through the ear buds. To answer the call, press the headset receiver's power button once or use your cell phone as you normally would.

Answering a call when listening to your iPod mini

To answer a call, press the headset receiver's power button once. When finished, press the power button again to resume listening to your iPod mini.

If the other party you are speaking with ends the call, audio transmission from your iPod mini will automatically resume without having to press the headset receiver's power button.

Ending a call

To end a call, press the headset receiver's power button once or use your cell phone as you normally would.

Rejecting a call

To reject an incoming call while the headset receiver is ringing, press and hold either Volume button for two seconds until the ear-buds emit two beeps.

Dialing from your cell phone

Simply make calls on your cell phone as you normally would.

Voice-dialing from your headset receiver

If your cell phone is equipped with a voice dialing function, simply press the headset receiver's power button once, wait until the ear-buds emit a beep, then say the voice tag.

Note: Please make sure to record the voice tag into the cell phone before using the voice-dialing function. The above function is only applicable to cell phones equipped with the Bluetooth Handsfree Profile. Functionality varies depending on the cell phone model. Please refer to your cell phone user's guide for additional instructions.

Product Specifications

Bluetooth Specifications:	Version 1.2
Bluetooth Profile Supported:	Headset, Handsfree and A2DP Profiles
Range of Frequency:	2.4GHz Spectrum
Nominal Charging Time:	Within 3 hours
Talk Time*:	Up to 5 hours
Stereo Playback Time*:	Up to 5 hours
Standby Time*:	Up to 125 hours

Troubleshooting

Symptom	Possible Problem	Solution
Unable to connect your headset receiver and cell phone.	The headset receiver is turned off.	Ensure your headset receiver is turned on and properly charged.
	The headset receiver is not paired with the cell phone.	Ensure the headset receiver is paired with the cell phone.
	The cell phone Bluetooth function is not activated.	Ensure the cell phone Bluetooth function is activated. Consult the cell phone user's guide for specific instructions.
	The headset receiver and cell phone are too far apart.	Ensure the headset receiver is within 30 feet (10 meters) of your cell phone and that there are no obstructions, such as walls or other electronic devices, in between.
	Built-in batteries may be too low.	Recharge the headset receiver and iPod mini transmitter and remove the cell phone battery for a while. Then retry.
Headset receiver is not responding.	The cell phone is not compatible with other Bluetooth-enabled products.	This iMotion mobile headset is compliant with and adopts the Bluetooth specification 1.2. However, interoperability between the device and other Bluetooth-enabled products is not guaranteed. For more information on the compatibility between your cell phone and other Bluetooth-enabled products, please check with the cell phone manufacturer.
	The headset receiver needs to be reset.	Turn off the headset receiver, then press the Volume "+" and "-" buttons simultaneously for two seconds to return to factory default settings. When the headset receiver is turned on again, the cell phone pairing will be cleared.

SAFETY INFORMATION

- Check local laws regarding use of a cell phone and headset while driving. If using a headset while driving, make sure your attention and focus remain on the road.
- Never allow children to play with any components of the inMotion mobile headset - small parts may be a choking hazard.
- Observe all signs that require an electrical device or RF radio product to be switched off in designated areas, including hospitals, blasting areas, and potentially explosive atmospheres.
- Turn off the inMotion mobile headset prior to boarding an aircraft. Do not use your inMotion mobile headset in an aircraft.
- Never mount or store your inMotion mobile headset over any airbag deployment area as serious injury may result when an airbag is deployed.
- Do not open or mutilate the built-in battery.

CARE AND MAINTENANCE

Headset receiver, iPod mini transmitter, ear buds

- Consider turning your inMotion mobile headset off before placing it in your pocket or bag. If the headset receiver's power button is accidentally depressed, your cell phone may place an unintended call. You may also use the "hold" switch to lock out all button commands.
- Do not expose the inMotion mobile headset to liquid, moisture, or humidity as it is not waterproof.
- Do not use abrasive cleaning solvents to clean the inMotion mobile headset.

16

- Do not expose the inMotion mobile headset to extremely high or low temperatures.

- Do not dispose of the inMotion mobile headset in a fire as it will result in an explosion.
- Do not expose your inMotion mobile headset to contact with sharp objects as this will cause scratches and damage.
- Do not stick anything inside the headset receiver, iPod mini transmitter or any other part of the inMotion mobile headset as this may damage internal components.
- Do not attempt to disassemble any part of the inMotion mobile headset as none of the parts contains serviceable components.
- If you do not use the inMotion mobile headset for long periods of time, be sure to store it in a dry place, free from extreme temperatures and dust.

Built-in batteries

- Do not attempt to replace the built-in batteries. They are not changeable or serviceable.
- Only charge the batteries in accordance to the instructions supplied in this user's guide.
- Only use the manufacturer-supplied charger when charging the headset receiver and iPod mini transmitter.

17

Charging

- Only use the manufacturer-supplied charger when charging the headset receiver and iPod mini transmitter.
- Do not disassemble the headset receiver, iPod mini transmitter, or charger as these parts may expose you to dangerous voltage or other risks. Incorrect reassembly can cause electric shock.
- Do not use the headset receiver or iPod mini transmitter in damp areas.
- Only charge the battery in accordance to the instructions supplied in this user's guide.
- Avoid charging the headset receiver and iPod mini transmitter in extremely high or low temperatures.

WARRANTY

Altec Lansing Technologies, Inc.

One Year Limited Warranty

(Two-Year Limited Warranty in The European Union and Asia)

What Does The Warranty Cover?:

Altec Lansing warrants that its products shall be free from defects in materials or workmanship, with the exceptions stated below.

What Is The Period Of Coverage?:

For units purchased in European Union or Asia, this warranty runs for two year from the date of purchase. For units not purchased in Europe or Asia, this warranty runs for one year from the date of purchase. The term of any warranties implied by law shall expire when your limited warranty expires. Some states and/or Member States in the European Union do not allow limitations on how long an implied warranty lasts, so the above limitation may not apply to you.

What Does The Warranty Not Cover?:

This warranty does not cover any defect, malfunction or failure that occurs as a result of: improper installation; misuse or failure to follow the product directions; abuse; or use with improper, unintended or faulty equipment.

(for information on proper installation, operation and use consult the manual supplied with the product. If you require a replacement manual, you may download a manual from www.alteclansing.com.) Also, consequential and incidental damages are not recoverable under this warranty. Some states do not allow the exclusion or limitation of incidental or consequential damages, so the above limitation or exclusion may not apply to you.

What Will Altec Lansing Do To Correct The Problem?:

Altec Lansing will, at its option, repair or replace any product that proves to be defective in material or workmanship. If your product is no longer being manufactured, or is out of stock, at its option, Altec Lansing may replace your product with a similar or better Altec Lansing product.

How To Get Warranty Service:

To get a covered product repaired or replaced, you must contact Altec Lansing during the warranty period by email (csupport@alteclansing.com). You must include in your email, your name, address, email address, telephone number, date of purchase and a complete description of the problem you are experiencing. In the United States, you may alternatively contact Altec Lansing by telephone at 1-800-ALTEC88 — please be prepared to provide the same information. If the problem appears to be related to a defect in material or workmanship, Altec Lansing will provide you a return authorization and instructions for return shipment. Return shipments shall be at the customer's expense, and the return must be accompanied by the original proof of purchase. You should insure the shipment as appropriate because you are responsible for the product until it arrives at Altec Lansing.

How Will State Law Affect Your Rights?:

This warranty gives you specific legal rights, and you may also have other rights which vary from state to state. Please note that in the European Union, you as a consumer might have other legal rights under national legislation of European Union Member States governing the sale of Altec Lansing's goods. Those rights are not affected by this guarantee.

The above limited warranties and remedies are sole warranties and remedies available to purchaser, if, and to the extent, valid and enforceable under the applicable law.

Changes or modifications not expressly approved by the party responsible for compliance could void the user's authority to operate the equipment

This device complies with Part 15 of the FCC Rules.

Operation is subject to the following two conditions:

- (1) this device may not cause harmful interference, and
- (2) this device must accept any interference received, including interference that may cause undesired operation.