

iRobot[®]

Looj[®]

Gutter Cleaning Robot

Model 330 Owner's Manual

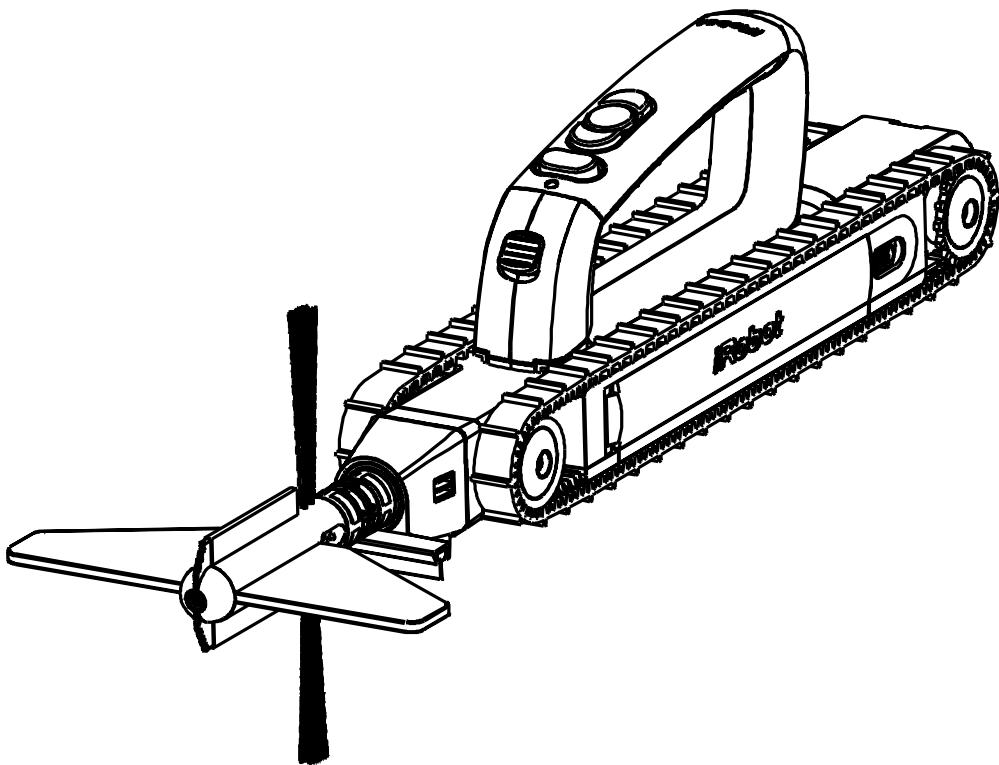

www.irobot.com

Welcome



Dear iRobot® Looj® Owner,

Welcome to the world of iRobot. As an owner of the iRobot Looj Gutter Cleaning Robot, you join a growing group of people around the globe who, like you, are discovering an easier way to clean their gutters.

The use of practical robots that help you in and around your home is a new reality. We encourage you to share your feedback as we continue to develop new and groundbreaking robots. Here's what you can do to participate in our efforts:

- Communicate with us if you have questions, comments or require support. Contact us at **www.irobot.com**.
- Register online at **www.irobot.com/register** or by phone (877.855.8593). You'll be among the first to hear about our newest robots, product enhancements, and special offers.

Thank you for joining the robot revolution. We look forward to your valued input as we continue to deliver groundbreaking products that will change and improve your world.

On behalf of the entire iRobot team,

A handwritten signature in black ink, appearing to read "Colin Angle".

Colin Angle
Co-Founder and CEO
iRobot Corporation

⚠ IMPORTANT: Make sure you read and follow all safety instructions and labels from your ladder manufacturer before attempting to use Looj. Failure to do so may result in serious injury or death.

Ladder Safety

- iRobot Looj enables you to clean a single run of gutter with one ladder position. Choose the safest ladder position possible along each run. Safe ladder positions are away from power lines, tree limbs, or other hazards, and provide a level surface to rest the ladder.
- Always inspect the ladder before you use it. Never use the ladder if it is damaged, broken or bent.
- Make sure the ladder is away from electrical wires, tree limbs, doors, or any other hazards when it is extended.
- Do not lean over the side of the ladder when using Looj. Never over-reach. Keep yourself balanced and centered over the ladder at all times.
- Keep both feet and one hand firmly on the ladder while placing Looj in the gutter and operating Looj.
- Keep the handle on Looj when placing it in and removing it from the gutter.
- Do not place Looj in the gutter while standing on a roof unless you are secured to the roof with a safety harness in accordance with the harness manufacturer's instructions.

Important Safety Instructions

**Looj is a gutter cleaning device; use only as intended.
For residential use only.**

READ ALL INSTRUCTIONS BEFORE USING LOOJ.

- This device has been tested and complies with FCC rules. Changes or modifications not expressly approved by the manufacturer will void your warranty.
- Always wear safety glasses when operating.
- Looj throws material clear of the gutter. Keep yourself and others out of path of flying debris. Make sure debris path below the gutter is clear of property, objects, and people.
- Always use the belt clip when carrying Looj, and keep both hands on the ladder while ascending and descending the ladder.
- Do not expose remote control handle to water.
- Do not allow water inside the robot. While the robot is intended to function in wet gutters, water intrusion will damage the robot. Always ensure the battery door is properly sealed before use. Do not expose the robot to water if battery door is not securely closed and latched.
- Do not attempt to service Looj yourself. Refer all non-routine servicing to qualified service personnel. Visit www.irobot.com/support for more information.
- Looj is not intended for children. Looj is not a toy. Do not sit or stand on this device. Small children and pets should be supervised if Looj is in use.
- Keep loose clothing, hair and body parts away from Looj while operating.
- Do not use this device near fire or high heat.
- Always remove the battery before long-term storage.
- Use only iRobot Looj batteries and chargers with this device.
- Charge using a standard outlet only. Do not use with any type of power converter — any such use will immediately void the warranty.
- Do not use the charger if the cord or plug is damaged.
- Charge indoors in a cool, dry location only.
- Always watch the robot when it is moving. If the robot starts to climb out of the gutter, stop and reverse direction.

Battery and Charger Safety

- Use only genuine iRobot rechargeable Lithium-Ion batteries and charger with Looj. Unauthorized replacements will void the warranty and may damage the product.
- Under normal conditions, the battery should charge within 3 hours. If not fully charged in 10 hours, discontinue charging.
- Charge between 5 to 35°C (40 to 95°F .)
- If corrosion or odor is detected upon first use, return the product immediately
- Do not pierce, puncture, disassemble or alter the battery.
- Do not short the positive (+) and negative (-) terminals of the battery with conductive materials (metal, wire, etc..)
- Do not allow the battery to be exposed to or immersed in water or other liquids
- Do not place battery in direct sunlight, heat, or fire. Batteries may explode if disposed of in fire.
- Do not subject the battery to shock or impact.
- Always use the correct line cord and plug for your type of outlet.
- Remove batteries from robot and remote control handle when not in use.
- For long term storage, store batteries in a cool, dry location.
- In the remote control, do not mix old and new batteries. Use only alkaline batteries. Do not use rechargeable batteries in the remote control.

Important Tips

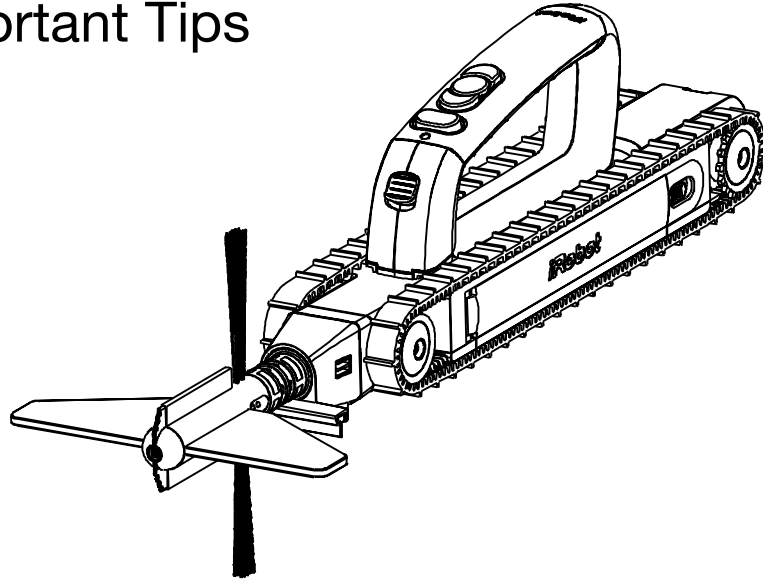

For Best Performance

- Between uses and for long-term storage, keep Looj and Looj battery in a cool, dry place and remove the batteries from the robot and remote control handle. Do not keep the battery on the charger during storage.
- Clean and dry Looj after each use.
- Fully charge the battery before long term storage.
- For best results, clean your gutters at least once per season. Clean regularly in areas where heavy debris collects.
- For very heavy debris run Looj forward in small increments to remove debris more gradually.
- Use fresh AAA batteries in the remote control handle for maximum range.

To see helpful operating and maintenance videos of Looj, please visit our website: **www.irobot.com**

Table of Contents

Ladder Safety	4
Important Safety Instructions	5-6
Important Tips	7
Table of Contents	8
Components.....	9
Product Description	10
Charging and Installing the Battery	11
The Remote Control Handle	12
Attaching the Looj Scraper.....	13
Attaching and Removing the Auger	14
Changing the Auger Ejectors	15
Attaching the Looj Belt Clip.....	16
Using iRobot Looj	17-20
Maintenance	21
Indicator Lights.....	22
Troubleshooting.....	23-24
iRobot Customer Care	24
Limited Warranty	25-26

iRobot® Looj® 300 Series Components

Robot

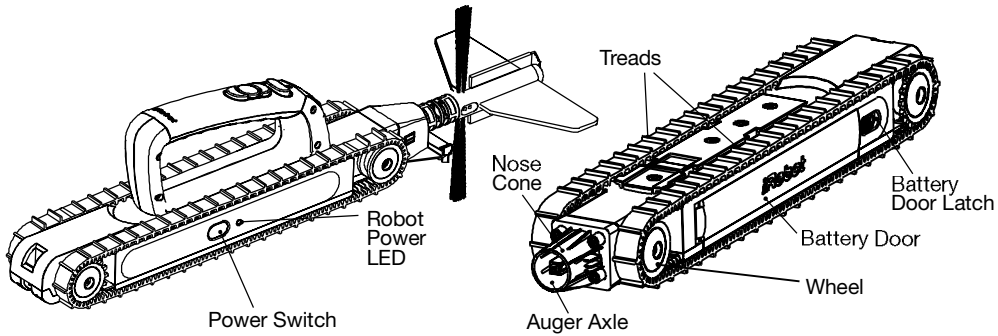

Included Ejectors	
Standard	
Compact	
Optional Ejectors	
Agitate	
Scoop	

Auger

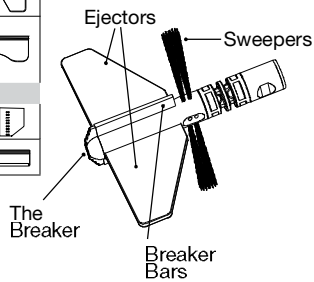

Remote Control Handle

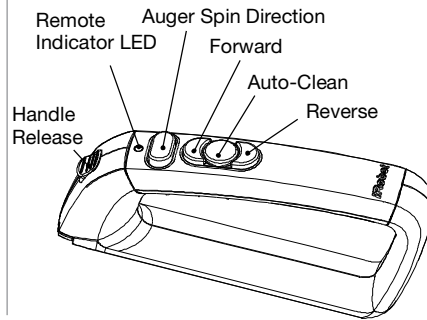

Battery and Charger

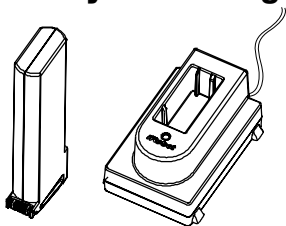

7.2V Rechargeable
Lithium-Ion Battery

Belt Clip

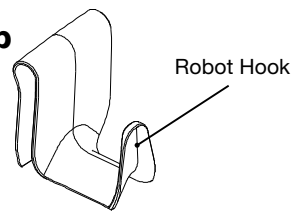

Scraper

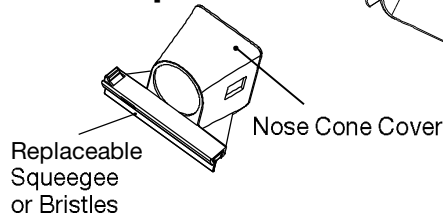

TIP: The charger line cord is included for the country or region where this robot was purchased. The shape of the plug varies with the country or region of purchase.

Product Description

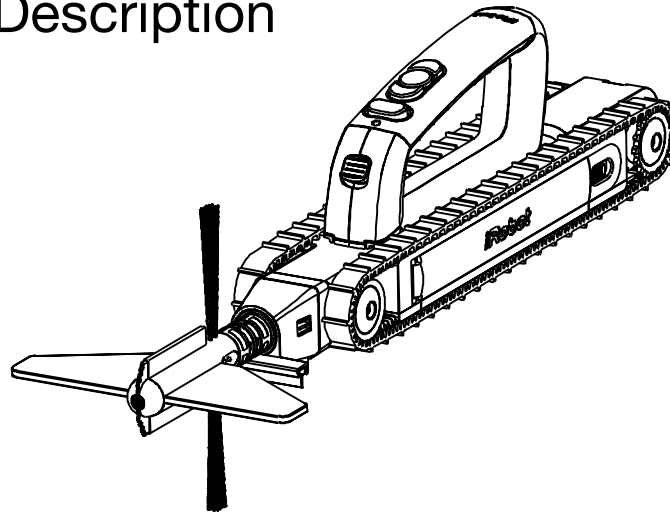

iRobot Looj is a powerful robot designed to clean gutters. Looj eliminates multiple climbs up and down the ladder. No more moving the ladder every six feet, or overreaching at dangerous heights. Looj has a number of features designed to make gutter cleaning simple and easy. Looj's ergonomic handle detaches for wireless control of the robot. The included belt clip lets you keep two hands on the ladder as you climb.

Cleaning Power: The robot uses a flexible four-stage auger to remove clogs, lift out debris, and brush your gutters clean. Spinning at 500 RPM, the high speed auger disrupts, lifts, and tosses debris out of your gutters.

Remote Control Convenience: The remote control gives you complete forward and backward control of the robot. You can also control the spin direction of the auger to make sure that gutter debris is tossed in the correct direction, away from the roof.

iRobot Looj works in most standard gutters with straps or ties mounted at least 2" above the bottom trough.

Tip: Remove items such as baseballs, large rocks, and tree branches by hand. Attempting to force Looj through solid debris could damage the robot.

Charging and Installing the Battery

Looj ships with a Lithium-Ion battery.

Be sure to fully charge the battery before first use. Fully charging the battery before every use will provide best performance.

Looj batteries are designed to power Looj through up to 200 linear feet of gutter on a single charge.

Between uses and for long term storage, remove the battery from the robot, and store in a cool, dry place.

Always use the correct line cord and plug that work with your type of electrical outlet.

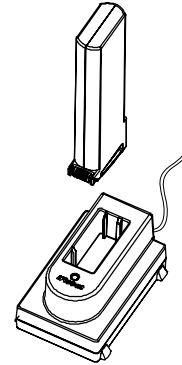

To install battery:

1. Slide the battery door latch and open the door.
2. Holding the battery by the finger holds on the end, label side up, slide the battery into the battery compartment attached to the battery door.
3. If dirty, wipe battery compartment door clean to ensure a proper seal.
4. Close door until it clicks.

⚠ CAUTION: Do not get water inside the robot.

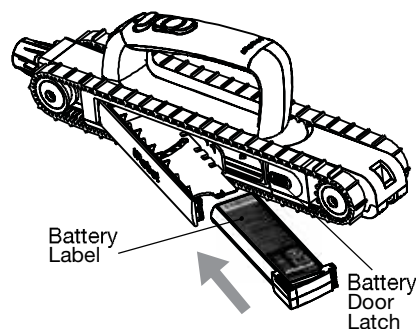

Battery Tips

- Remove all batteries from the robot and store in a cool, dry place after each use.
- See www.irobot.com/support for more details on Looj batteries and charging.
- Store at temperature range 5 to 25°C (40 to 80 °F).

⚠ CAUTION: In case of any battery issues always contact iRobot Customer Care first. For return purposes never ship Li-ion batteries via air freight. Always ship ground. Always place the battery in its own resealable bag to protect from battery shortage during ground shipping.

The Remote Control Handle

TIP: Push any button to power on the remote. A green LED will flash to indicate that the remote has power.

The remote control handle detaches from Looj and is used to command the robot from a distance of up to 45 feet, depending upon environmental conditions. The remote control handle keeps your hands clean and makes it easy to place the robot in and out of the gutter using only one hand. Install two AAA alkaline batteries in the remote control handle before operating.

Don't mix battery types or brands. Use fresh batteries for maximum performance and range.

Insert AAA batteries into the remote control handle as shown.

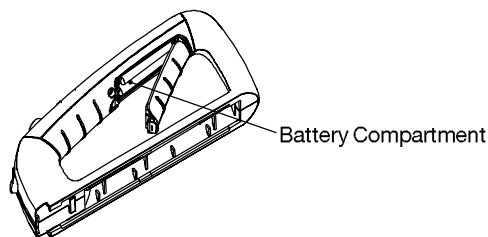

To attach the remote control handle to Looj:

1. Hold the remote control handle and align the front edge with the label on the robot.
2. Slide the remote control handle forward until it clicks.
3. When you hear a click, the handle is latched in place.

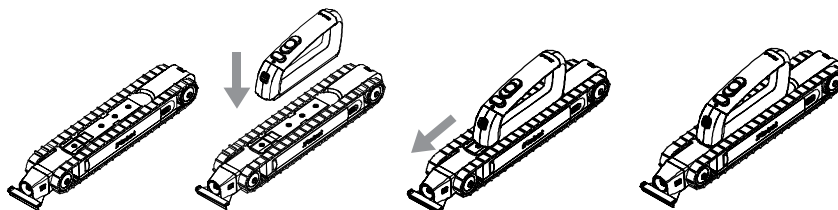

TIP: Make sure handle is securely attached to the robot before picking up the robot.

To remove the remote control handle from Looj:

Push down handle release button and slide remote control handle away from auger.

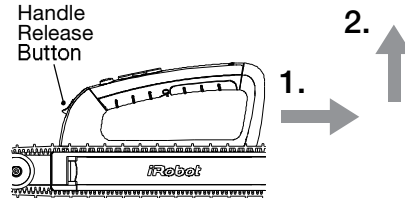

Attaching the Looj Scraper

The Looj scraper is designed to clip over the nose cone of the robot. It provides optional added cleaning performance by scraping the gutter floor clear of debris.

Slide the scraper over the nose cone until it clicks and locks onto the robot. To remove, pinch the two color buttons on both sides of the scraper and pull off the robot.

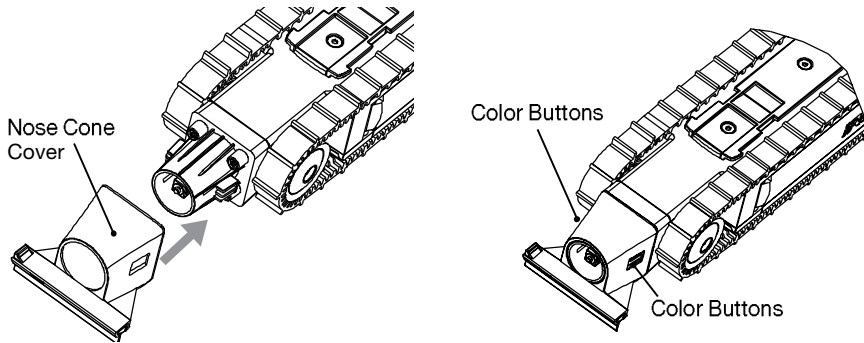

The scraper has standard replaceable rubber squeegees and optional accessory bristles. To interchange between these two styles, simply grasp the lip on the end and pull the slide out. To replace, slide the piece onto the scraper until it locks.

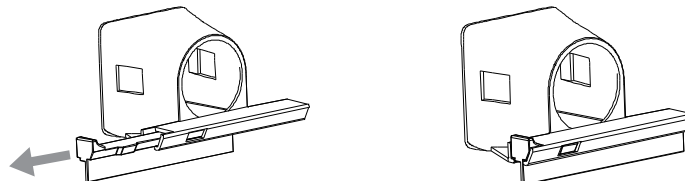

Attaching the Auger

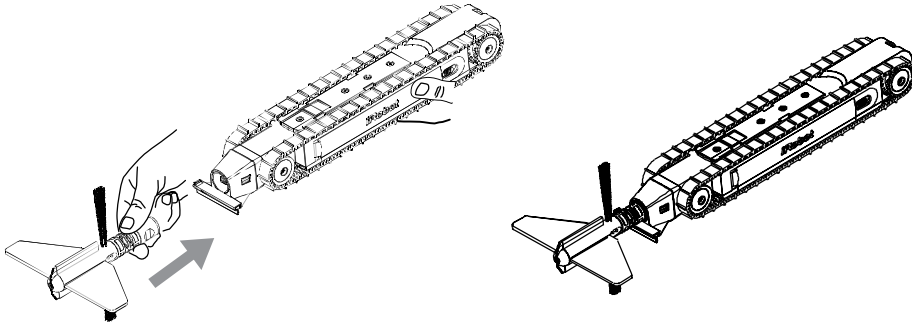

Push the auger onto the robot auger axle until you feel it snap into place and hear a click.

Removing the Auger

Grasp auger at the finger indentation and pull.

⚠ CAUTION: Grabbing and pulling the auger at the ejectors could cause a tear.

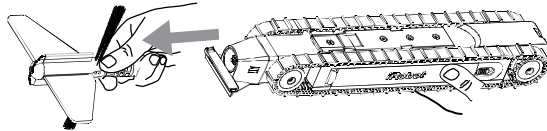





TIP: If the auger is difficult to attach or remove, try wetting the auger axle with a small amount of water.

Changing the Auger Ejectors

Your Looj comes with a set of standard ejectors that are capable of handling the most common gutter cleaning conditions. Additional ejector styles can be purchased separately. When you first open your new Looj you will need to assemble the auger with the ejectors of your choice. Follow the instructions below for proper assembly.

Ejector Styles

Included Ejectors	
Standard	
Compact	
Optional Ejectors	
Agitate	
Scoop	

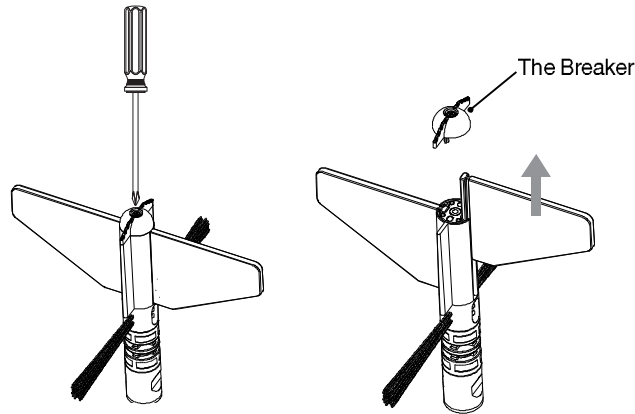

Use a Phillips® screwdriver to remove the breaker. Slide the ejector out of the auger assembly.

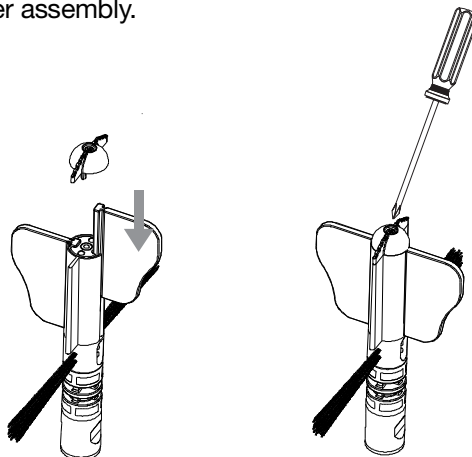

Slide the newly selected ejector onto the auger assembly. Ensure that you place the ejector in the correct orientation as marked on the ejectors. Fasten the breaker back on to secure.

Attaching the Looj Belt Clip

The Looj belt clip is designed to hold Looj while you climb up and down the ladder. Always use the belt clip when using Looj on a ladder.

Hook the belt clip over your belt where Looj will be secure and easy to reach. Attach the robot to the robot hook.

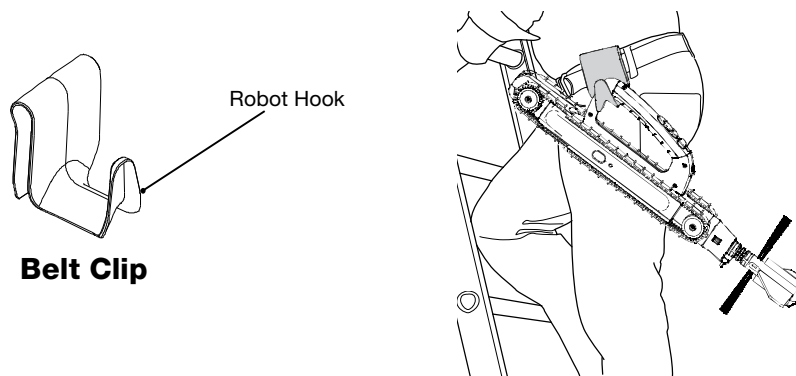

⚠ CAUTION: Always keep the belt clip on the side of your body. Placing the robot in the front may cause it to be kicked by your leg and fall off.

⚠ CAUTION: Never use Looj on a ladder without the belt clip to hold the robot while you ascend or descend.

Using iRobot® Looj®

⚠ IMPORTANT: The robot is only intended to clean in the forward direction. Always have the auger spinning when moving the robot.

Tip: Learn about Looj on the ground first, not on a ladder.

1. Drive it forward and backward on the ground. Verify that the lights on the remote control handle and on the robot blink when buttons are pressed.
2. Spin the auger in both directions.

Read about and practice operating all the buttons and controls before use. For more information on the light indicators and functions of the button controls, see the tables on page 22. Practice attaching and detaching the handle as described on page 12.

Using Looj

1. The optimum spot for ladder placement is away from wires, hazards, on flat ground, etc. Read and follow ladder instructions provided by the ladder manufacturer before using a ladder. See “Important Safety Instructions” section for more details.

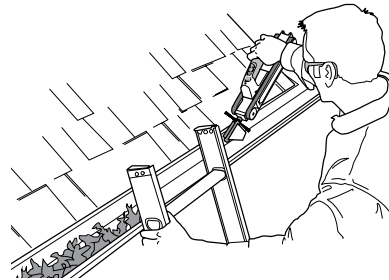

2. Attach belt clip to belt and attach Looj to the belt clip.
3. Climb the ladder.
4. Remove debris from one end of the gutter to clear a space for the Looj. Place Looj in gutter. Remove debris from gutter directly in front of ladder. Otherwise, you may be sprayed by debris when Looj begins to operate.

⚠ CAUTION: Always keep both feet and one hand on the ladder.

iRobot

⚠ CAUTION: Wear safety glasses when using Looj to protect your eyes from debris.

⚠ CAUTION: Do not stand underneath the gutter while Looj is operating.

5. Press the power button on the robot to turn it on. The power light should be green to indicate that its battery is charged. A slow blinking red light indicates that you should charge Looj's battery. (For all LED indicators please see the indicator lights section on Page 22.)

6. Detach the remote control handle.

7. Select your auger direction. If you press the left arrow of the auger spin direction button (A), debris will be thrown to the left. If you press the right arrow, it will be thrown to the right (B).

TIP: Note that one direction will spin the debris away from the building and the other direction will spin the debris onto the roof. Test the spin direction before driving the robot down the gutter.

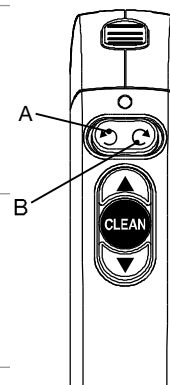

8. Ensure that the auger is spinning and tossing debris out of the gutter and away from the building.
9. Press the "CLEAN" button if you would like the robot to clean your gutter on its own in auto-mode. Press any button to cancel out of auto modes at any time. At the end of the "CLEAN" cycle, you will have to drive the robot back to you manually.
10. To drive the robot in manual mode press the forward and backward buttons to drive the robot through the gutter and remove debris. Press the forward button once and then hold to go at half speed for tough clogs. Double click the back button to go into auto-reverse mode.

⚠ CAUTION: Always watch the robot when cleaning in auto mode. If the robot starts to climb out of the gutter for any reason, push any button to cancel and then drive the robot backwards.

11. The LED on the remote control handle will display different messages depending on what the robot is doing. For a list of all LED indicators, please see the indicator lights section on page 22.

12. Once Looj reaches the end of the gutter, drive it back to you. Keep the auger spinning to help drive under the gutter straps.

TIP: Should the robot ever turn sideways or flip over in your gutter, spin the auger in the opposite direction and back the robot up to right itself.

TIP: Never start Looj while the auger is in front of you on the ladder. Always clear the debris near the ladder by hand, and drive the robot with auger pointed away from you to avoid debris spray.

13. Turn off the power switch off on the robot. The remote will power off on its own after a time delay.

14. Attach the remote control handle to remove Looj from the gutter and clip Looj to the belt clip before descending.

15. Descend the ladder following safety instructions from ladder manufacturer. See Page 4 for more ladder safety warnings.

Robot Controls

Robot buttons and controls	Robot Action
Handle Release Button	Detaches the handle from the robot
Auger Spin (Direction Left)	Spins the auger to the left
Auger Spin (Direction Right)	Spins the auger to the right
Auger Neutral Position (Button in Center Position)	Auger will not spin (Do not use while driving in gutter)
Press and Hold Forward Button	Moves the robot forward
Press and Hold Reverse Button	Moves the robot backward
Click once and Hold Forward Button	Moves the robot forward at half speed
Double Click Reverse Button	Automatically backs the robot up. No need to hold the backward button.
Press "Clean" Button	Puts the robot in auto mode to clean your gutters on its own

Handling Dense Clogs

Looj can handle most debris found in your gutter. Occasionally, there may be heavy debris that will not clear in a single pass. Should this situation arise, it's important not to force the robot into the debris.

To handle heavy clogs, leave the auger on and drive the robot slowly forward until the auger contacts the clogged debris. Press the forward button twice and hold to proceed at half speed. Allow the auger to eject a small amount of debris. If Looj gets stuck, reverse direction and allow the auger to clear away the debris that have loosened. Repeat this process until the clogged debris is fully cleared.

⚠ CAUTION: If Looj begins to climb up over debris, STOP MOVING THE ROBOT FORWARD and back it up. If you drive the robot over debris and up the side of the gutter, you risk it falling out of the gutter which may cause injury. Never let anybody stand below the gutter during robot operation.

Maintenance

Cleaning Looj

Make sure the battery door is securely closed before cleaning. Looj is designed to be easily cleaned with a hose or under a faucet. No chemicals should be used to clean Looj. Prior to cleaning, remove the remote control handle and treads from the robot. Clean any debris from Looj's wheels.

Looj's remote control handle should be cleaned with a damp cloth only. The remote control handle is not waterproof. Damage may occur to the electronics if it is sprayed with water or submerged.

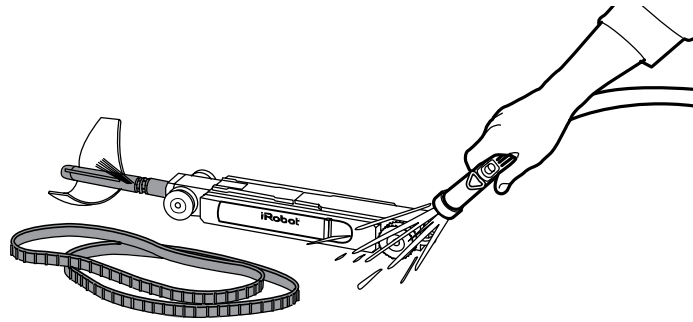

⚠ CAUTION: After the battery is removed, wipe edges of battery compartment door with a dry cloth to ensure proper seal.

⚠ CAUTION: Always keep the battery door closed when cleaning the robot to avoid damage to the product or battery. The battery is not waterproof so water will cause battery damage.

⚠ CAUTION: Dry the robot thoroughly before opening the battery door. Do not allow water to get inside the robot.

Storing Looj

Store iRobot Looj and its battery between 5° - 25° C (40° - 80° F). Excessive heat or cold may reduce battery life and product performance. For best results, we recommend removing both the battery from the robot and the batteries from the remote control handle when the product is stored. Store Looj and batteries in a dry location.



Indicator Lights

Remote Control Handle LED:	What it means
Solid Green	This indicates that the power is on, battery is charged, and all communication is okay. This light will only be on when robot is moving.
Slow Blinking Green	This occurs for 5 seconds to indicate that the remote has connected to the robot.
Solid Yellow	This indicates that the robot and remote have a low signal strength. Stop forward progress and return the robot to you. Driving the robot out of range risks losing communication and control of the robot.
Slow Blinking Yellow	This occurs for 15 seconds to indicate that the remote has lost connection with the robot. If this occurs, move closer to the robot making sure you are within range of the robot - 15 m (45 ft). Also, make sure that the robot is powered on.
Fast Blinking Yellow	This indicates that the robot has sensed tough debris. The robot will over-ride your commands until it is clear of the debris, at which point you can begin commanding the robot again. Note: This warning does not occur in "CLEAN" mode. The robot will change its behaviors automatically in "CLEAN" mode.
Solid Red	This indicates that the robot has encountered a failure. You must retrieve the robot and attempt to reset the power button. Make sure to clear the robot of any debris jams and ensure all batteries are fresh or fully charged. If the solid red LED remains, please call a customer care representative to help troubleshoot your robot.
Slow Blinking Red	This indicates a low battery. If in use, return the robot to you immediately, then charge the robot's battery and use fresh batteries in the remote.

Robot LED:	What it means
Solid Green	This indicates that the power is on, the battery is charged and all communication is okay.
Slow Blinking Green	This occurs for 5 seconds to indicate that the robot has connected to the remote.
Solid Yellow	This indicates that the robot has a weak signal strength.
Slow Blinking Yellow	This occurs if the robot has lost connection with the remote.
Fast Blinking Yellow	This indicates that the robot has sensed tough debris. The robot will over-ride your commands until it is clear of the debris, at which point you can begin commanding the robot again. Note: This warning does not occur in "CLEAN" mode. The robot will change its behaviors automatically in "CLEAN" mode.
Solid Red	This indicates that the robot has encountered a failure. You must retrieve the robot and attempt to reset the power button. Make sure to clear the robot of any debris jams and ensure all batteries are charged. If the solid red LED remains, please call a customer care representative to help troubleshoot your robot.
Slow Blinking Red	This indicates a low battery. If in use, return the robot to you immediately, then charge the robot's battery and use fresh batteries in the remote.

Charger Light	What it means
Slow Blinking Green	The battery is connected to the charger and is charging.
Fast Blinking Green	There is an error and the battery is not charging. Please make sure the battery is properly seated in the charger and is making proper contact. If the problem persists, contact customer care.
Solid Green	The battery is fully charged.

Troubleshooting

Refer to the chart below to resolve Looj's problem. If the problem is not resolved, visit www.irobot.com/support.

Observation	Likely Cause	What to do
Remote transmission light does not light up on the remote.	Remote batteries were inserted incorrectly or have depleted.	Check the battery orientation or replace with fresh batteries.
Robot is not responding to the remote control handle.	Robot power is off or there is radio interference between the remote control handle and robot.	Check to see that the robot power button is on and both robot and remote control handle lights are flashing when a remote button is pressed. If not, try to improve reception by raising the remote control handle above the height of the gutter while operating. Make sure you are within range of the robot - 15 m (45 ft).
Auger will not insert into robot.	Insertion hole is clogged.	Clean out hole with toothpick or compressed air.
Auger is spinning but robot is not moving.	Robot movement has stopped due to debris stuck in robot treads.	Retrieve robot, clean the wheels and test it on the ground to make sure it is operating properly before placing back into the gutter.
Robot is stuck on gutter strap.	Gutter strap is too low or improperly installed.	Check gutter strap for previously existing damage or improper installation. Looj fits under all standard 2" gutter strap installations.
Robot is not cleaning effectively.	Ejector not suited for debris type.	Change to different ejector on auger.
Robot is throwing debris on roof.	Auger direction is incorrect.	Change the auger direction.

Improving the range of the remote control handle

Should you experience signal loss from the remote control handle to iRobot Looj while it is cleaning, try to improve reception by raising the remote control handle above the height of the gutter.

Robot Controls

Robot buttons and controls	Robot Action
Handle Release Button	Detaches the handle from the robot
Auger Spin (Direction Left)	Spins the auger to the left
Auger Spin (Direction Right)	Spins the auger to the right
Auger Neutral Position (Button in Center Position)	Auger will not spin (Do not use while driving in gutter)
Press and Hold Forward Button	Moves the robot forward
Press and Hold Reverse Button	Moves the robot backward
Click once and Hold Forward Button	Moves the robot forward at half speed
Double Click Reverse Button	Automatically backs the robot up. No need to hold the backward button.
Press "Clean" Button	Puts the robot in auto mode to clean your gutters on its own

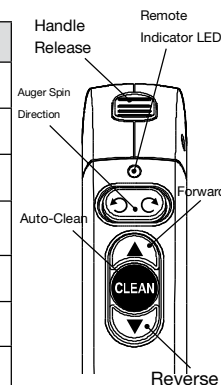

iRobot Customer Care USA

If you have questions or comments about this product please contact iRobot before contacting a retailer.

Please visit www.irobot.com for support tips, frequently asked questions, or information about accessories and other iRobot products. We would like to hear from you.

Should you still need assistance:

- Visit the iRobot support site at www.irobot.com/support
- Call our customer care representatives at 877.855.8593

iRobot Customer Care Hours:

- Monday – Friday 9AM – 7PM Eastern Time
- Saturday 9AM – 6PM Eastern Time

iRobot Customer Care International

To contact an international partner near you for sales and technical support, visit www.irobot.com/international.

LIMITED WARRANTY TO ORIGINAL PURCHASER

LIMITED WARRANTY TO ORIGINAL PURCHASER

This iRobot brand product, as supplied and distributed by iRobot Corporation, and delivered as manufactured, in the carton to the original customer purchaser, is warranted by iRobot Corporation against manufacturing defects in materials and workmanship for the qualifying limited warranty period as follows:

One year LABOR AND PARTS: This limited warranty begins on the original date of purchase, and is valid only on products purchased from iRobot authorized dealers and is valid on products used in North America, and does not include installation, removal or reinstallation. Warranty repairs must be performed by iRobot Corporation's authorized service center. To receive warranty service, the original dated bill of sale from an iRobot authorized dealer must be presented upon request as proof of purchase to iRobot Corporation's authorized service center. To obtain warranty service, support or other information, please visit our website at www.irobot.com or by calling 877-855-8593.

iRobot Corporation will repair or replace this product, at our option and at no charge with new or reconditioned parts, if found to be defective during the limited warranty period specified above. To request service, the original purchaser must contact iRobot Corporation for problem determination and service procedures. iRobot Corporation does not warrant uninterrupted or error-free operation of the product. All replaced parts and products become the property of iRobot Corporation and must be returned to iRobot. Replacement parts and products assume the remaining original warranty, or 60 days, whichever is longer. This limited warranty covers manufacturing defects in materials and workmanship encountered in normal, and, except to the extent otherwise expressly provided in this statement, non-commercial use of this product and shall not apply to the following, including but not limited to: damage which occurs in shipment; applications and uses for which this product was not intended; failures or problems which are caused by products or equipment not supplied by iRobot Corporation; accidents, misuse, abuse, neglect, misapplication, fire, water, lightning or other acts of nature; incorrect electrical line voltage, fluctuations or surges; damage caused by improper installation; product alteration or modification; improper or unauthorized repair; exterior finish or cosmetic damage; failure to follow operation instructions, customer adjustments, maintenance and environmental instructions that are covered and prescribed in the instruction book; use of non-iRobot or unauthorized parts, supplies, accessories or equipment which damage this product or result in service problems; failures or problems due to incompatibility with other equipment.

THERE ARE NO EXPRESS WARRANTIES OTHER THAN THOSE LISTED AND DESCRIBED ABOVE, AND NO WARRANTIES WHETHER EXPRESS OR IMPLIED, INCLUDING, BUT NOT LIMITED TO, ANY IMPLIED WARRANTIES OF MERCHANTABILITY OR FITNESS FOR A PARTICULAR PURPOSE, SHALL APPLY AFTER THE EXPRESS WARRANTY PERIOD STATED ABOVE, AND NO OTHER EXPRESS WARRANTY OR GUARANTY GIVEN BY ANY PERSON, FIRM OR CORPORATION WITH RESPECT TO THIS PRODUCT SHALL BE BINDING ON



IROBOT CORPORATION. IROBOT CORPORATION SHALL NOT BE LIABLE FOR LOSS OF REVENUE OR PROFITS, FAILURE TO REALIZE SAVINGS OR OTHER BENEFITS, OR ANY OTHER SPECIAL, INCIDENTAL OR CONSEQUENTIAL DAMAGES CAUSED BY THE USE, MISUSE OR INABILITY TO USE THIS PRODUCT, REGARDLESS OF THE LEGAL THEORY ON WHICH THE CLAIM IS BASED, AND EVEN IF IROBOT HAS BEEN ADVISED OF THE POSSIBILITY OF SUCH DAMAGES. NOR SHALL RECOVERY OF ANY KIND AGAINST IROBOT CORPORATION BE GREATER IN AMOUNT THAN THE PURCHASE PRICE OF THE PRODUCT SOLD BY IROBOT CORPORATION AND CAUSING THE ALLEGED DAMAGE. WITHOUT LIMITING THE FOREGOING, PURCHASER ASSUMES ALL RISK AND LIABILITY FOR LOSS, DAMAGE OR INJURY TO PURCHASER AND PURCHASER'S PROPERTY AND TO OTHERS AND THEIR PROPERTY ARISING OUT OF THE USE, MISUSE OR INABILITY TO USE THIS PRODUCT SOLD BY IROBOT CORPORATION NOT CAUSED DIRECTLY BY THE GROSS NEGLIGENCE OF IROBOT CORPORATION. THIS LIMITED WARRANTY SHALL NOT EXTEND TO ANYONE OTHER THAN THE ORIGINAL PURCHASER OF THIS PRODUCT, IS NONTRANSFERABLE AND STATES YOUR EXCLUSIVE REMEDY.

Some states do not allow limitations on how long an implied warranty lasts, or the exclusion or limitation of incidental or consequential damages, so the above limitations or exclusions may not apply to you. This warranty gives you specific legal rights and you may also have other rights, which vary from state to state.

FCC Notice: This equipment has been tested and found to comply with the limits for a Class B digital device, pursuant to Part 15 of the FCC Rules. These limits are designed to provide reasonable protection against harmful interference in a residential installation. This equipment generates uses and can radiate radio frequency energy and, if not installed and used in accordance with the instructions, may cause harmful interference to radio communications. However, there is no guarantee that interference will not occur in a particular installation. If this equipment does cause harmful interference to radio or television reception, which can be determined by turning the equipment off and on, the user is encouraged to try to correct the interference by one or more of the following measures:

- Reorient or relocate the receiving antenna.
- Increase the separation between the equipment and receiver.
- Connect the equipment into an outlet on a circuit different from that to which the receiver is connected.
- Consult the manufacturer, dealer, or an experienced radio/TV technician for help.

⚠ WARNING: Changes or modifications not expressly approved by iRobot could void your warranty.

This device complies with RSS-210 of the Industry Canada Rules. Operation is subject to the following two conditions: (1) This device may not cause harmful interference, and (2) this device must accept interference received, including interference that may cause undesired operation.

This device complies with Part 15 of the FCC Rules. Operation is subject to the following two conditions: (1) this device may not cause harmful interference, and (2) this device must accept any interference received, including interference that may cause undesired operation.

Get iRobot accessories at:
800.727.9077 or visit **store.irobot.com**

International customers visit global.irobot.com.

iRobot[®]

2008-2012 iRobot Corporation, 8 Crosby Drive, Bedford, MA 01730 | All rights reserved. iRobot and Looj are registered trademarks of iRobot Corporation. U.S. Pat. <http://www.irobot.com/patent> | Patents pending. [4369902 Rev A]