



Mint Plus Owner's Manual

Model Number 5200
www.mintcleaner.com
1.888.543.6468

TABLE OF CONTENTS

- ◆ Safety Instructions / PAGE 4
- ◆ Mint Plus Overview / PAGE 6
- ◆ Buttons and Lights / PAGE 8
- ◆ Battery and Charging / PAGE 10
- ◆ Sweeps and Mops / PAGE 12
- ◆ How Mint Cleans / PAGE 14
- ◆ NorthStar Navigation / PAGE 16
- ◆ Operating Mint / PAGE 18
- ◆ Maintenance / PAGE 22
- ◆ Customer Support / PAGE 23
- ◆ Trouble Shooting / PAGE 24
- ◆ Limited Warranty / PAGE 38

IMPORTANT SAFETY INSTRUCTIONS

TO REDUCE THE RISK OF FIRE, ELECTRIC SHOCK, OR INJURY

CAUTION: DO NOT EXPOSE THE ELECTRONICS OF MINT PLUS, ITS BATTERY OR THE ADAPTER. THERE ARE NO USER-SERVICEABLE PARTS INSIDE. REFER SERVICING TO QUALIFIED SERVICE PERSONNEL.

WARNING: READ AND SAVE THESE INSTRUCTIONS.

To avoid the risk of injury or damage, these basic precautions should always be followed:

- ◆ Read all safety and operating instructions before using Mint Plus.
- ◆ Read and heed all warnings in this manual and on Mint Plus, the Cube and the adapter.
- ◆ Only use Mint Plus in accordance with the specifications outlined in this manual.
- ◆ Do not attempt to repair or adjust any electrical or mechanical functions on this device. Tampering with these functions may create a hazardous condition, and it will void your warranty.
- ◆ Be aware that floors may be slippery after wet cleaning with Mint Plus.
- ◆ Mint Plus operates very quietly. Take care when walking in the area Mint Plus is cleaning to avoid stepping on Mint Plus and tripping.

USE RESTRICTIONS

- ◆ Mint Plus is not a toy. Supervise children and pets when Mint Plus is cleaning.
- ◆ Mint Plus has electrical parts. Do not spray, rinse or submerge it in water. Clean with a dry cloth only.
- ◆ Mint Plus is for household use only.
- ◆ Mint Plus is for indoor use on hard surface floors only.
- ◆ Do not use Mint Plus to pick up large debris, liquid spills, bleach, paint, or other chemicals.
- ◆ Do not use Mint Plus near any objects that are burning or smoking.

- ◆ Before using Mint Plus, remove fragile objects from the cleaning area, including objects on furniture that can fall if the furniture is pushed or bumped.
- ◆ Move any power cords as well as cords for blinds and curtains out of the way to reduce the risk of objects being pulled down.
- ◆ Do not operate Mint Plus in areas with exposed electrical outlets in the floor.
- ◆ Block off access to open balconies near the cleaning area with physical barriers.
- ◆ Do not place anything on top of Mint Plus.
- ◆ Follow instructions on Page 18 for attaching the cleaning cloth to ensure proper function of all sensors.
- ◆ When mopping, do not use Mint Plus in areas where wetness can damage unfinished or unsealed floors or delicate carpeting or rugs.
- ◆ Operate at room temperature. Do not expose Mint Plus or its batteries to freezing or extreme heat.

BATTERY AND CHARGING

- ◆ Charge using a standard U.S. (120V AC) outlet only.
- ◆ Only use the included adapter to charge Mint Plus.
- ◆ Only use rechargeable battery packs approved by the manufacturer.
- ◆ Do not use an adapter with a damaged cord or plug.
- ◆ Do not handle or charge Mint Plus when hands are wet.
- ◆ Always disconnect Mint Plus from the adapter before cleaning.

Notice: Mint Plus contains a software interface for the purpose of enabling the manufacturer to provide updates to the internal firmware if any such updates are made available to users. Any attempt to access, retrieve, copy, modify, distribute or otherwise use any of the Mint Plus software is strictly prohibited.

Proposition 65 Warning: This product contains chemicals known to the state of California to cause cancer and birth defects or other reproductive harm.

Mint Plus Overview

Mint Plus

- ① Control Buttons
- ② NorthStar® Navigation Sensor
- ③ Navigation System Indicator
- ④ Furniture Guard Bumper
- ⑤ Handle
- ⑥ Cube on/off button (on back corner)
- ⑦ Removable Cleaning Pad

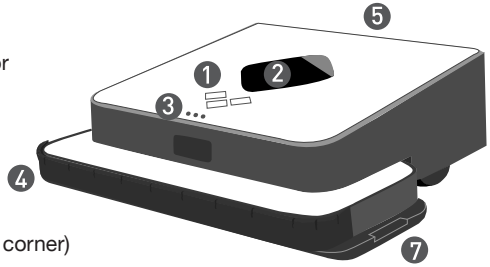

NorthStar® Navigation Cube

- ⑧ Battery Charging Port
- ⑨ Floor Transition Sensors
- ⑩ Wheel Guards
- ⑪ Charging Adapter

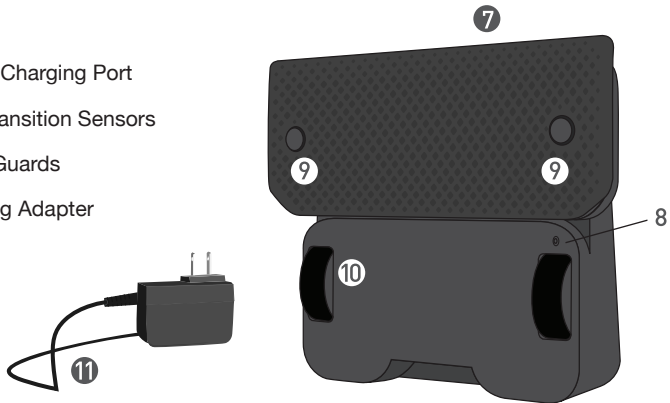

Multi-Purpose Cleaning Pad

For dry sweeping or wet mopping, disposable or reusable microfiber cloths.

- 12 Cloth Gripping Strips
- 13 Middle Channel for Floor Transition Sensors

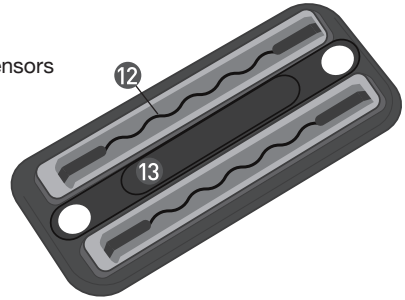

Pro-Clean Reservoir Pad

For wet mopping with the blue Pro-Clean microfiber cleaning cloth.

- 14 Fill cap
- 15 Reservoir
- 16 Wick

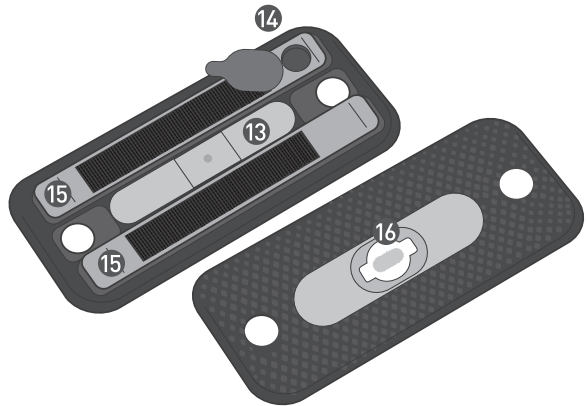

Buttons and Lights

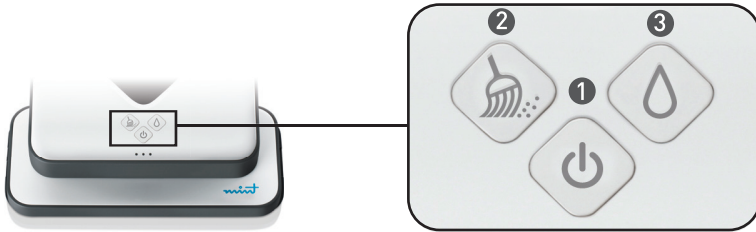

① Power Button

Press once to turn Mint Plus on.
Hold for 2 seconds to turn Mint Plus off.

Blue solid light: Power on

Red blinking light: Battery starting to get low

Red solid light: Low battery (needs to be recharged)

② Sweep Button

For use with dry cloths.

Press once to start cleaning.*
Press while cleaning to pause.

Blue solid light: Sweep mode activated

Blue blinking light: Sweep mode paused

③ Mop Button

For use with wet cloths.

Press once to start cleaning.*
Press while cleaning to pause.

Blue solid light: Mop mode activated

Blue blinking light: Mop mode paused

* Holding the cleaning mode button will activate Quick Clean Mode. See page 15

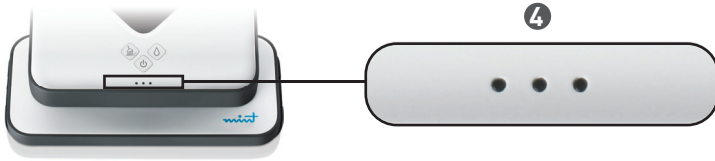

4 Navigation System Indicators

NorthStar Connection

Blue blinking light (1): Establishing connection

Blue solid light (1 to 3): Locked onto NorthStar Cube

The number of lights indicates the strength of Mint Plus's connection to the navigation system, with 3 being strongest. If there are no lights, Mint Plus does not detect a NorthStar signal.

Other States

Blue lights flashing in sequence: Thinking

Blue lights flashing with pause: Sleep mode

Red light in middle: Error*

**See trouble shooting section for more information.*

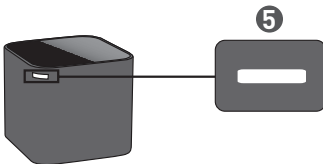

5 NorthStar® Navigation Cube Lights

Blue blinking light: Power on, broadcasting signal

Blue solid light: Power on, connected to Mint Plus

Red solid light: Batteries low

Battery and Charging

Mint Plus comes with a rechargeable battery. On a full charge, it will clean up to 4 hours dry sweeping or up to 2.5 hours wet mopping.

Charging

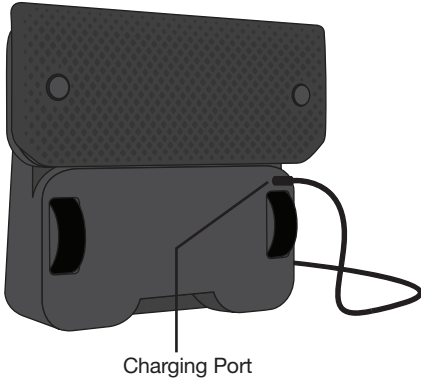

- ◆ Stand Mint Plus on its end to access the charging port.
- ◆ Plug the adapter into a standard electrical outlet and into Mint Plus's charging port.
- ◆ Charge Mint Plus for approximately 4 hours or until a solid blue light appears on the power button*.
- ◆ It may take Mint Plus a few charging cycles to reach its full capacity.

** The blue light indicates on average that the battery has charged to 80% of its capacity. Mint Plus will continue to charge while plugged in. If you experience short run times, charge for 8 hours or more to improve performance.*

Charging time and run time can be affected by operating temperature, floor type and other conditions.

Tip: Mint Plus can also be charged with the Mint Plus Turbo Charge Cradle. See Cradle instructions for details.

⚠ Caution:

Do not charge Mint Plus while the Pro-Clean reservoir pad or any wet cloth is attached.

Charge using a standard U.S. (120V AC) outlet only.

Only use the included adapter to charge Mint Plus.

Always disconnect Mint Plus from the adapter before cleaning.

Charging Indicators

(While Plugged In)

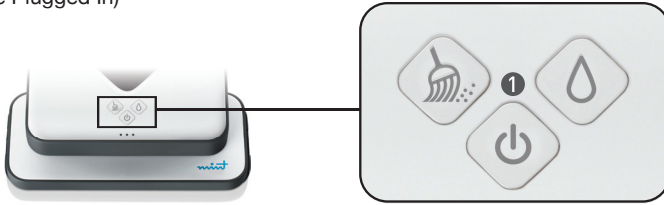

1 Power Button

Red pulsing light: Battery charging

Blue solid light: Battery charged

The NorthStar Navigation Cube

The Cube uses 2 C batteries. The battery door can be found on the bottom of the Cube.

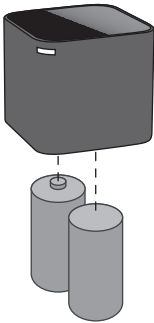

Please dispose of all batteries properly by finding a recycling resource near you.

Sweep and Mop Modes

Mint Plus sweeps and mops hard surface floors using readily available dry and wet cleaning cloths or the included reusable microfiber cloths.

Mint Plus is not a vacuum and is not intended for use on carpets.

Sweep Mode

Sweep mode is intended for cleaning with a *dry cloth*.

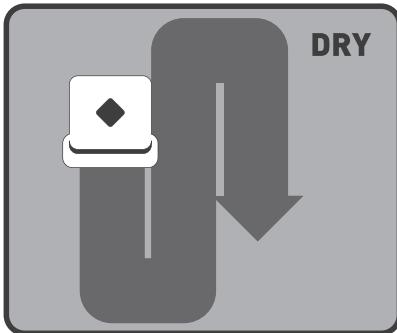

- ◆ In sweep mode, Mint Plus moves ahead in a straight line when it begins cleaning, then cleans back and forth in parallel lines.
- ◆ It is ideal for picking up dust, dirt and hair to maintain clean, grit-free floors every day.

Mop Mode

Mop mode is intended for cleaning with a *wet cloth*.

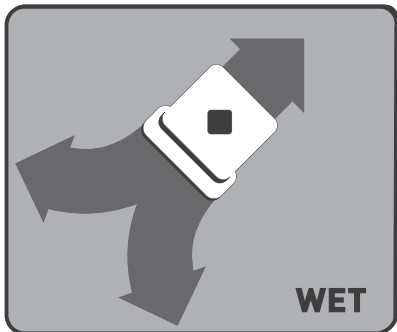

- ◆ In mop mode, Mint Plus drives forward a short distance to one side, backs up slightly then moves forward to the other side, alternating to the left and right as it progresses.
- ◆ This mopping action helps dissolve and pick up the deeper dirt and grime on your floors.
- ◆ Mint Plus automatically adjusts to a smaller cleaning area in mop mode to optimize cleaning while the cloth is wet.

Tip: Start with dry sweep mode to pick up surface grit and then follow with a wet cloth in mopping mode to get a deeper clean.

Cleaning Cloths

Disposable Cloths

For use only with the Multi-Purpose Cleaning Pad.

- ◆ Mint Plus is compatible with most disposable dry and pre-moistened cleaning cloths such as Swiffer® brand and store brands like Target®.
- ◆ Always follow the use and care instructions included with any dry or wet cleaning cloths to care for your floors.
- ◆ Please note that Mint Plus is not compatible with Swiffer® **WetJet®** Refills.

Microfiber Cloths

Mint Plus's specially designed microfiber cloths can be rewashed and reused.

- ◆ White cloths are for dry sweeping with the Multi-Purpose Cleaning Pad.
- ◆ Blue textured cloths are for mopping and can be used with either the Pro-Clean Reservoir Pad or the Multi-Purpose Cleaning Pad. Dampen cloth before use.
- ◆ Grey textured cloths (sold separately) can be used with the Multi-Purpose Cleaning pad, but should NOT be used with the Pro-Clean Reservoir Pad.

Notice: Wet cloths may not be suitable for cleaning unsealed floors. Ask your flooring manufacturer or installer if you are unsure whether damp mopping is safe for your floor.

Floor Types

- ◆ Mint Plus is designed to clean hard surface floors including wood, tile, vinyl, linoleum and laminate.
- ◆ Mint Plus cleans best on smooth hard surfaces and may not perform on uneven tiles, heavily waxed floors or rough surfaces like slate or brick which can snag the cleaning cloth.

Notice: Mint Plus is not intended to pick up large debris. Before cleaning with Mint Plus, pick up large debris and check for gravel or sharp objects that could scratch the floor if captured under the cleaning pad.

How Mint Plus Cleans

Mint Plus intelligently cleans your floor by mapping the room as it cleans.

Cleaning Cycle

- ◆ Mint Plus cleans your home in sections, first cleaning areas to its right and later returning to areas to its left.
- ◆ When the open areas in each section are complete, Mint Plus cleans along edges of furniture and walls before moving on.
- ◆ When finished, Mint Plus returns to where it started and parks itself.

Cleaning Pattern

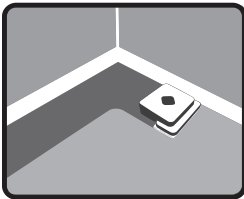
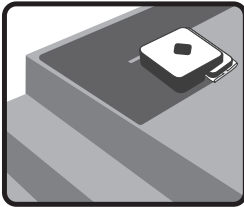
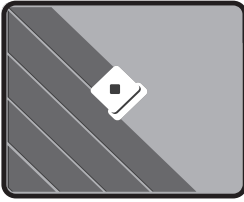

- ◆ In open areas, Mint Plus methodically cleans back and forth across your floor.
- ◆ As Mint Plus encounters chair legs, furniture and other obstacles, it cleans around them and continues its cleaning pattern.
- ◆ Mint Plus detects stairs and will maneuver away from drop offs and back to the cleaning area.

As a safety precaution, open ledges or balconies with a drop of 2 feet or more should be blocked off with a physical barrier.

- ◆ Mint Plus also detects area rugs and raised transitions to carpet so it can avoid driving on to them.

Note: If your carpet is flush with your hard surface floor, you may need to add a temporary barrier to provide Mint Plus a boundary it can detect.

- ◆ Mint Plus follows along walls and edges as it encounters them and as it completes each section it cleans.

Quick Clean Mode

Cleans 30% faster by focusing cleaning on open areas.

- ◆ Activate by holding the Sweep or Mop button for 3 seconds.
- ◆ You will hear a single beep followed by the “start cleaning” song.
- ◆ Mint Plus typically cleans the same total area as the standard detailed cleaning mode, but will skip detailed cleaning around furniture and some walls to save time.

Pause / Resume

Mint Plus will automatically pause if you pick it up or press any button while cleaning.

- ◆ The cleaning mode button will flash blue to indicate the cleaning cycle is paused. While paused, Mint Plus will save the map of the area it has already cleaned.
- ◆ To resume cleaning, place Mint Plus within 6 feet of the Cube where it originally started, facing in the same general direction it started.
- ◆ Press the flashing cleaning mode button.
- ◆ Mint Plus will start cleaning while it determines its position on the map. Once it confirms its position, it will drive to an area not yet covered and continue cleaning.
- ◆ Mint Plus may re-clean an area already covered or explore new areas of cleaning while determining its position on the map.
- ◆ If you resume Mint Plus where you paused it, it may take longer for the cleaner to determine its position depending on its distance from the Cube.
- ◆ To exit Pause and quit the cleaning cycle, power Mint Plus off by holding the power button for 2 seconds.

Note: Mint Plus can only be paused after it has locked onto the NorthStar Navigation Cube at the beginning of the cleaning cycle.

NorthStar® Navigation

The NorthStar Navigation Cube acts as a beacon, emitting a signal that guides Mint Plus's cleaning.

Connecting to the NorthStar Navigation Cube

- ◆ Once Mint Plus starts cleaning, it tries to establish a connection to the NorthStar Navigation Cube, indicated by one flashing blue light on the Navigation System Indicator. Once Mint Plus has locked onto the Cube, Mint Plus's lights turn solid blue.
- ◆ The Navigation System Indicator also indicates Mint Plus's range. As Mint Plus gets to the edge of its range (such as going out of the room or far from the NorthStar Navigation Cube) the number of lights will go down.
- ◆ Mint Plus may occasionally drive back toward the NorthStar Navigation Cube to confirm its position before continuing on its cleaning path.
- ◆ Mint Plus builds a new map each time it starts a new cleaning cycle, but retains its map if paused during the cleaning cycle.

Cleaning without a NorthStar Navigation Cube:

Because the Cube is just one part of the Navigation System, Mint Plus can still clean without a NorthStar signal present, however the cleaning area will be much smaller and Mint Plus will not be able to perform edge cleaning in each section.

Cleaning with multiple NorthStar Navigation Cubes:

Mint Plus can use multiple NorthStar Cubes to extend cleaning coverage up to 2,000 square feet when dry sweeping. Mint Plus will move from one Cube to the next, extending the cleaning area with each Cube it encounters.

Multiple cubes can be used in Mop mode, too, but Mint Plus limits its wet cleaning area to 350 square feet to optimize for cloth wetness.

Setting Up NorthStar Navigation Cubes

Using Mint Plus with one Cube

- ◆ Place the Cube near the center of the area you want to clean and start Mint Plus nearby.
- ◆ Mint Plus will clean the area around the Cube, and may extend into other rooms based on the cleaning mode and how far the NorthStar signal reaches.
- ◆ If you have a choice of rooms, place the Cube in a larger room to maximize NorthStar coverage.
- ◆ Once Mint Plus has completed its run, you can move the Cube to clean a different part of your home.

Using Mint Plus with multiple Cubes

- ◆ Use one or more extra Cubes (sold separately) to expand how far Mint Plus cleans in a single run.*
- ◆ Place extra Cubes in rooms or areas next to the area covered by the first Cube. The Cubes should typically be between 20 and 25 feet from each other for the NorthStar coverage to overlap.
- ◆ Mint Plus will automatically clean from one Cube to another.

*Cubes are pre-programmed to different NorthStar channels, indicated on the bottom of the Cube. Cubes with different channels must be used for multi-Cube cleaning.

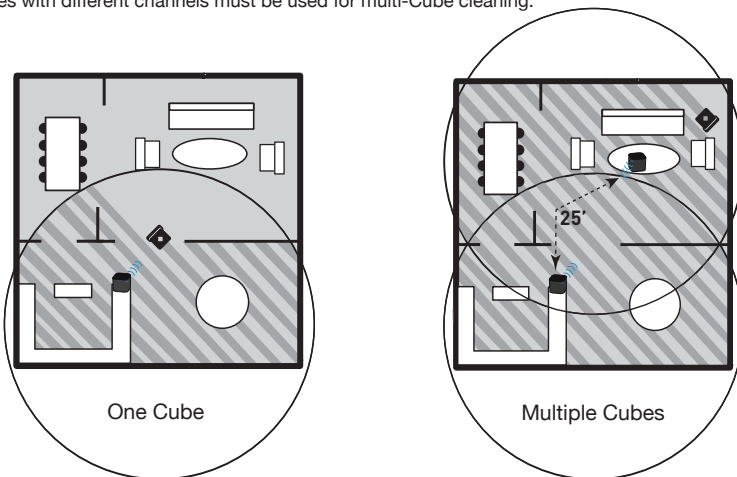

Operating Mint Plus

Put On a Cleaning Cloth

1

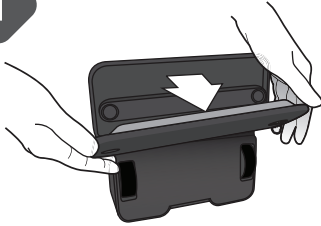

- ◆ Set Mint Plus on its end and remove the cleaning pad.

2

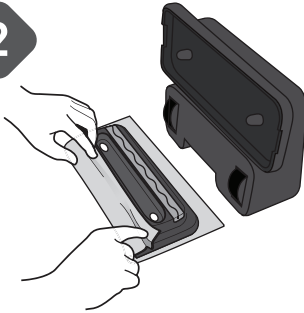

- ◆ Attach a dry or wet cloth to the Multi-Purpose cleaning pad.
 - ◆ Lay the removable pad on an open cleaning cloth.
 - ◆ Attach cloth by tucking it into the gripping strips on both sides.
- ◆ See page 19 for the Pro-Clean Reservoir Pad.

3

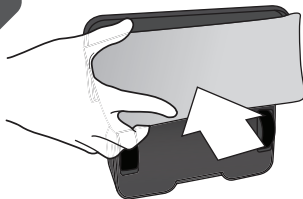

- ◆ Re-attach the cleaning pad. Magnets will help it snap back into place.

4

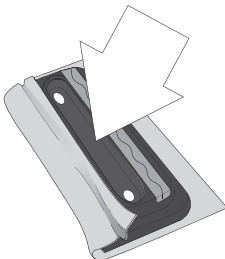

⚠ Caution: Make sure the cleaning cloth does not drape into the middle channel between the gripping strips as this could impede sensor functions and safe operation.

Using the Pro-Clean Reservoir Pad

The Pro-Clean Reservoir Pad dispenses liquid as Mint Plus mops to keep the cleaning cloth wet longer.

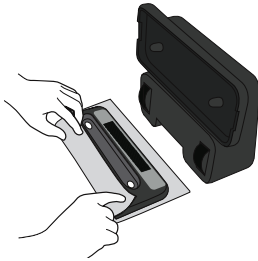
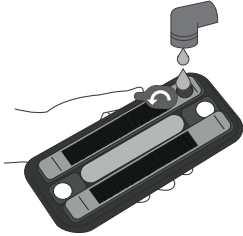

Fill the reservoir

- ◆ Open the fill cap by pulling and swiveling it to the side.
- ◆ Fill reservoir with water and replace fill cap, pressing it in securely so it does not leak. Visit www.mintcleaner.com for information about other cleaning solutions.
- ◆ Fill the reservoir over a sink as a small amount of fluid can leak out when the fill cap is closed.
- ◆ Dampen the blue Pro-Clean microfiber cloth and press onto the velcro strips.

Tip: Fluid dispenses at different rates depending on floor type and solution used. The first time you mop, start with the cloth only slightly damp and then increase the starting cloth wetness if needed.

Notice: To avoid the Pro-Clean Reservoir Pad leaving excess fluid on your floor, do not leave Mint Plus unattended when mopping and remove from floor once Mint Plus stops cleaning.

When mopping is finished:

- ◆ Empty any remaining fluid from the reservoir.
- ◆ Leave the fill cap open to allow reservoir to dry completely. Do not store the pad on Mint Plus if wet.
- ◆ See page 23 for care instructions.

Operating Mint Plus

Place the NorthStar® Cube

1

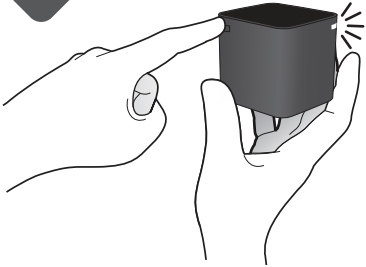

- ◆ Press the button on the back corner of the NorthStar Navigation Cube to turn it on. *A blue light will flash on the opposite corner when turned on, and then go solid when Mint Plus locks onto it.*
- ◆ If you forget to turn the Cube on, Mint Plus will send a signal to try to turn it on. *If Mint Plus is successful, the blue flashing light will appear on the Cube.*

2

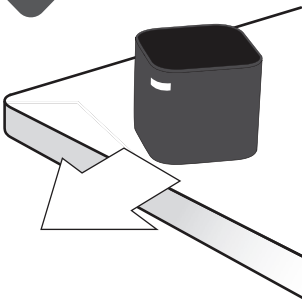

- ◆ Place the NorthStar Navigation Cube on a table or counter top, pointing the blue light away from walls and toward the middle of the room.

For Best Results

- ◆ Place the NorthStar Navigation Cube where it has a clear view of the ceiling (for example, no cabinet or shelf directly above it).
- ◆ Do not move the NorthStar Navigation Cube once Mint Plus has started cleaning as it may impair Mint Plus's cleaning performance.
- ◆ Do not put the NorthStar Navigation Cube on the floor as the cleaner may run into it and move it.

Start Cleaning

Place Mint Plus on the floor within 6-8 feet of the NorthStar Navigation Cube.

1

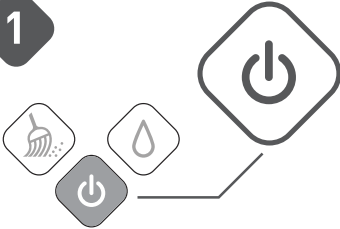

- ◆ Turn Mint Plus on using the power button. *The button will light up blue when the cleaner is on.*

2

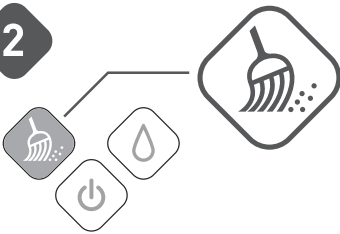

- ◆ To start cleaning with a DRY CLOTH just press the Sweep button.

3

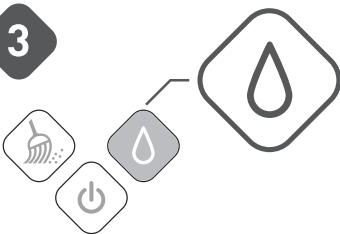

- ◆ To start cleaning with a WET CLOTH just press the Mop button.

- ◆ One blue light will start blinking on the Navigation System Indicator if Mint Plus detects a signal from the Cube. The light will turn solid blue once it locks onto the Cube. *If no lights appear, Mint Plus does not detect a NorthStar signal.*
- ◆ When Mint Plus finishes cleaning, it plays a short song, returns to where it started and parks itself. *Mint Plus will also do this if the battery runs low while cleaning.*
- ◆ To turn Mint Plus off, press the power button for two seconds. A tune will play and the light will turn off.
- ◆ To turn off the NorthStar Navigation Cube, press the button on the back corner. The light on the opposite corner will turn off.

Maintenance

To keep your Mint Plus in the best working condition, follow these maintenance steps.

Cleaning and Storing

- ◆ Use a dry cloth to wipe dust or dirt from Mint Plus's exterior. Do not rinse or submerge in water.
- ◆ Use a damp cloth to wipe off dust and dirt on tires. Make sure that Mint Plus is not plugged in and that the cloth is not dripping.
- ◆ Place Mint Plus on its end (handle side down) when charging or storing between uses.
- ◆ For long term storage remove C batteries from the NorthStar Cube.

Wheel Guard

- ◆ As Mint Plus cleans, debris may accumulate around the Wheel Guards. This helps keep Mint Plus's wheels moving freely.
- ◆ Periodically check Mint Plus's wheels to see if debris has accumulated and remove as needed.
- ◆ A small notch next to the wheel allows access with tweezers or scissors if needed to free the debris.

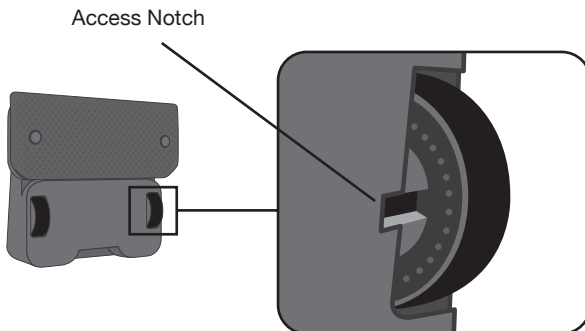

Pro-Clean Reservoir Pad

- ◆ Hand rinse with water in the sink to clean. *Do not put the reservoir pad in the dishwasher. Do not wash with soap.*
- ◆ Let dry completely before re-attaching to Mint Plus after cleaning is complete.
- ◆ The wick is designed for repeated use and includes antimicrobial material. Do not remove the wick cap between cleanings.
- ◆ If the wick cap becomes dirty or shows wear, it can be replaced.
 - ◆ Remove the wick cap by pulling on the side rubber tab.
 - ◆ Replace with a new wick cap, pressing firmly into place to create a tight seal to prevent leaking.
 - ◆ An extra wick cap is included with Mint Plus or can be found at www.mintcleaner.com

Customer Support

Visit www.mintcleaner.com for:

- ◆ frequently asked questions
- ◆ online help
- ◆ information about replacement parts and service.

Or call us at 1.888.543.6468. We're here to help.

Register Your Mint Plus Online

It's easy! Your registration allows us to share important product updates and helps us serve you better.

Visit **www.mintcleaner.com/register**

Trouble Shooting

Visit www.mintcleaner.com for additional tips and trouble shooting.

Problem

Mint Plus won't start cleaning

Mint Plus is cleaning only a small area

Solution

- ◆ Confirm the unit is powered on (a blue light will appear under the power button, bottom center. If a red light appears, the cleaner requires charging before it can clean).
 - ◆ Make sure the removable cleaning pad is securely attached and that the cleaning cloth is tucked cleanly into the gripping strips or onto the velcro strips.
 - ◆ If the power is on, press the sweep button to clean with a dry cloth or the mop button to clean with a wet cloth. Mint Plus should start cleaning in 2-3 seconds.
-
- ◆ Mint Plus requires the NorthStar Navigation Cube to maximize its cleaning area. Make sure the Cube is in the area you want to clean.
 - ◆ Confirm the NorthStar Navigation Cube is on. A blue light will appear in one corner if the power is on.
 - ◆ Check the position of the NorthStar Navigation Cube to make sure there is no interference.
 - ◆ The Cube should have a clear view of the ceiling. Place the Cube in an open area without a cabinet overhang or shelf directly above it.
 - ◆ If there is a moving ceiling fan above the Cube, turn the fan off or move the Cube so it is not beneath the fan.
 - ◆ If the ceiling is high or uneven, try moving the Cube to an area with a lower and more even ceiling.
 - ◆ If the Cube is close to a wall, make sure the blue light faces away from the wall and into the room.
 - ◆ Do not move the Cube during the cleaning cycle.

Trouble Shooting Cont'd

Visit www.mintcleaner.com for additional tips and trouble shooting.

Problem

Mint Plus isn't driving properly

Mint Plus is not connecting to the NorthStar Navigation Cube

(Mint Plus's Navigation System Indicator keeps blinking blue and does not go solid)

Solution

- ◆ If cleaning with a wet cloth in Mop mode, try cleaning with a dry cloth in Sweep mode on the same floor surface to determine if the issue occurs in both modes.
 - ◆ If using a cleaning solution on a wet microfiber cloth, try cleaning with only water to determine if the solution could be causing Mint Plus to slip.
 - ◆ Make sure the cleaning cloth is attached properly and that the removable cleaning pad is securely reattached to Mint Plus.
 - ◆ Try cleaning with a dry cloth in Sweep Mode on a different type of hard floor to determine if the issue may be related to floor type such as an uneven floor surface.
-
- ◆ Try these steps to help Mint Plus and the Cube find each other.
 - ◆ Turn off both Mint Plus and the Cube
 - ◆ Turn the Cube back on using the button on its corner. A blinking blue light should appear on the opposite corner.
 - ◆ Place the Cube on a table or counter with the blinking blue light pointed toward an open floor area where you can place Mint Plus.
 - ◆ Put Mint Plus on the floor in that open area about 6-7 feet from the Cube, with Mint Plus facing toward the Cube.
 - ◆ Turn Mint Plus on and press the Sweep button (use a dry cleaning cloth).
 - ◆ Mint Plus should move toward the Cube (and then away from it again as it encounters a wall or obstacle) and its blue lights should go from blinking to solid within a minute or so.
 - ◆ When cleaning, position Mint Plus so it faces toward the Cube when it starts to help it connect.

Trouble Shooting Cont'd

Visit www.mintcleaner.com for additional tips and trouble shooting.

Problem

Mint Plus will not turn on

All of the lights flash on the cleaner when I plug it in

There is a red light on Mint Plus's power button

Solution

- ◆ Plug the included adapter into the cleaner and charge the battery until the power button light turns solid blue while the adapter is plugged in.
 - ◆ If charging does not work, make sure the rechargeable battery is securely connected.
 - ◆ Remove the battery door cover on the bottom of the cleaner with a screwdriver.
 - ◆ Disconnect and re-connect the rechargeable battery pack via the small white plug.
 - ◆ Replace the battery door and tighten the screw.
 - ◆ Press the power button.
-

- ◆ An incompatible adapter has been connected to Mint Plus.
 - ◆ Remove the incompatible adapter and connect the adapter that was included with Mint Plus.
-

- ◆ A solid red light on Mint Plus's power button indicates it needs to be charged.
 - ◆ Power Mint Plus off and plug in the included adapter.
 - ◆ Charge the battery until a solid blue light appears on Mint Plus's power button.
- ◆ If Mint Plus's power button still shows a red light after charging, make sure Mint Plus is plugged into the correct adapter.
- ◆ A flashing red light on the power button indicates the battery is low, but Mint Plus still has cleaning time left.

Trouble Shooting Cont'd

Visit www.mintcleaner.com for additional tips and trouble shooting.

Problem

Mint Plus has a red light, beeps 3 times when I push Sweep or Mop and won't clean

There is a solid red light on Mint Plus's middle Navigation Indicator

There is a blinking red light on Mint Plus's middle Navigation Indicator

Solution

- ◆ If the red light turns off after the 3 beeps, but occurs again when you press the Sweep or Mop button, Mint Plus is not ready to clean due to an activated sensor.
 - ◆ Check to make sure:
 - ◆ Both ends of the cleaning cloth are securely tucked into the blue gripping strips or onto the Pro-Clean velcro strips and the cloth is not bunching up.
 - ◆ The cleaning cloth is not in the middle channel of the removable cleaning pad.
 - ◆ The removable, magnetic cleaning pad is firmly reattached to Mint Plus.
-

- ◆ Press Mint Plus's power button for 5-6 seconds to power it off.
 - ◆ Manually rotate both of Mint Plus's wheels and set Mint Plus on the floor.
 - ◆ Power Mint Plus back on.
 - ◆ If the red light is gone, press the Sweep button to confirm Mint Plus can now drive forward.
 - ◆ If the red light persists or recurs, contact customer support.
-

- ◆ Mint Plus has encountered a problem in its environment and needs help. Problems could include getting physically stuck or being unable to find its way out of a confined area.
- ◆ Mint Plus will also periodically play a two-tone distress sound to alert you it needs help.
- ◆ Remove Mint Plus from its situation.
- ◆ Mint Plus will go into Pause mode when moved.
- ◆ Place Mint Plus back on the floor near the Cube where it started.
- ◆ Press the blinking cleaning mode button to resume cleaning.

Trouble Shooting Cont'd

Visit www.mintcleaner.com for additional tips and trouble shooting.

Problem

The Navigation System Indicator on Mint Plus does not show any lights

Mint Plus is stopped and blue lights are flashing.

There is a red light on the NorthStar Navigation Cube

The NorthStar Navigation Cube won't turn on

The NorthStar Navigation Cube periodically shuts down

Solution

- ◆ Mint Plus does not detect a NorthStar signal.
 - ◆ Make sure the NorthStar Navigation Cube is in the room and turned on (a blue light will show in one corner of the Cube).
-
- ◆ If Mint Plus is left untouched for more than 5 minutes after it finishes a cleaning cycle, it goes into sleep mode and the blue indicator lights will appear in sequence. Press any button to wake it.
-
- ◆ The batteries are low. Replace with 2 new C batteries.
-
- ◆ The batteries may be dead. Replace with 2 new C batteries.
-
- ◆ There may be interference with the NorthStar signal from some televisions and fluorescent lights.
 - ◆ Make sure the NorthStar Navigation Cube is not placed within 5 feet of a Plasma or LCD television.
 - ◆ If the Cube is in a room with fluorescent light, move the Cube to an area without fluorescent light or turn the fluorescent light off.
 - ◆ If Mint Plus has traveled out of range for a while, the NorthStar Navigation Cube may turn itself off, but when Mint Plus returns it will send a message to the Cube to turn it back on.

Trouble Shooting Cont'd

Visit www.mintcleaner.com for additional tips and trouble shooting.

Problem

Multiple Cubes are set up, but Mint Plus is only using the first Cube.

Multiple Cubes are set up, but Mint Plus is over-cleaning many areas.

When resuming after pausing, Mint Plus cleans the same area again.

When resuming after pausing, Mint Plus does not go back to where it left off.

Mint Plus drives off when I start cleaning and does not move straight ahead then to its right.

Solution

- ◆ Mint Plus must be able to encounter the second Cube while cleaning to lock onto it, so make sure the second Cube is not isolated in an area where Mint Plus cannot get to it.
 - ◆ Try placing the Cubes with just 15 feet between them to help Mint Plus connect. If the Cubes are in rooms separated by a hallway, place the Cubes near the entrance to each room.
 - ◆ Start Mint Plus near one Cube, but facing the other.
 - ◆ Once Mint Plus successfully locks onto both Cubes (one at a time), progressively move them farther apart for subsequent cleaning cycles (do not move the Cubes while Mint Plus is cleaning).
-

- ◆ Confirm the Cubes in use all have different channels. The channel number can be found on the bottom of each Cube.
-

- ◆ It is normal for Mint Plus to re-clean an area while trying to find its position on the map.
 - ◆ To help Mint Plus find its position quickly, restart it near the Cube in the same orientation and location where it originally started.
 - ◆ Mint Plus will clean in the area it is re-started while trying to find its position. If Mint Plus cannot find the NorthStar signal or its position, it will start a new cleaning cycle and continue cleaning.
-

- ◆ In some cases, Mint Plus may choose to clean another area not yet covered before returning to the area where it was paused.
 - ◆ If Mint Plus does not successfully lock onto NorthStar and find its position, it will start a new cleaning cycle.
-

- ◆ Mint Plus may still be in Pause mode from a previous cleaning run.
- ◆ If either the Sweep or Mop button is blinking blue, tap the power button once to get out of pause mode.

Trouble Shooting Cont'd

Visit www.mintcleaner.com for additional tips and trouble shooting.

Problem

The Pro-Clean Reservoir Pad is leaking.

The Pro-Clean Reservoir Pad is not wicking out fluid.

The Pro-Clean Reservoir Pad is leaving puddles on the floor.

Mint Plus's run time is shorter than expected.

Solution

- ◆ Check the fill cap and the wick cap to make sure they are both securely attached and sealed shut.
-

- ◆ An air intake hole on the bottom of the Reservoir Pad allows fluid to wick. Make sure it is not plugged or obstructed.
 - ◆ To check, fill the Reservoir Pad all the way and then push down on the fill cap to seal it. A small amount of liquid should escape through the air intake hole, indicating it is not plugged.
 - ◆ If the air intake hole is clear, replace the wick cap. See instructions on page 23.
-

- ◆ Check the fill cap and the wick cap to make sure they are both securely attached and sealed shut. Fluid will dispense at a faster rate if these caps are not sealed.
 - ◆ When you wet the blue cleaning cloth before cleaning, make sure it is only slightly damp.
 - ◆ Cleaning solutions can dispense at different rates. If using a cleaning solution, try using only water in the reservoir to see if it dispenses more slowly.
-

- ◆ Mint Plus may not have reached its full battery capacity while fast charging. Leave Mint Plus plugged in and it will continue to charge at a slower pace to fill any remaining capacity.
- ◆ Temperature can affect charging rate and time. If it is over 85 degrees and Mint Plus is running continuously, let Mint Plus cool down before charging.

Limited Warranty

Evolution Robotics, Inc. (“ER”) warrants that this Mint Plus automatic floor cleaner product (the “Product”) will be free from manufacturing defects in materials and workmanship for a period of 1 year (the “Warranty Period”) from the date of purchase to the original purchaser (the “Purchaser”). Please save your original sales receipt to validate the start of the Warranty Period.

If the Product becomes defective during the Warranty Period, ER will, at its option, repair, adjust, or replace the Product or its components. ER may, at its option, use new, reconditioned or substitute parts or Products. For warranty support, Purchaser must contact ER to obtain service instructions and warranty authorization by visiting www.mintcleaner.com or calling 1.888.543.6468. Purchaser may be required to deliver the defective Product to an authorized service center. If ER cannot reproduce the claimed defect Purchaser may be responsible for the costs of shipping and diagnostics. All returned parts and Product will become the property of ER. In general, you will need to deliver the Product in its original packaging or equally protective packaging to the address specified by customer support.

This Limited Warranty applies only to Products purchased in North America and operated under normal installation, use and service conditions. Warranty coverage will not apply to any damage or failure of the Product which ER determines is due to any other causes, including but not limited to: (i) failure to follow proper assembly, installation, operation, maintenance, and safety instructions as described in the owner’s manual; (ii) use in environments or for purposes for which the Product was not designed; (iii) negligence, abuse, accident, or other physical damage; (iv) unauthorized repairs, alterations, or modifications; (v) use of any parts (such as a battery or charger) not provided by ER or combining the Product with other components not intended or recommended for use with the Product; (vi) wear and tear or cosmetic damage; (vii) causes beyond ER’s control including fire, flood, wind, freezing, power failure, generalized corrosion, biological infestations, unusual atmospheric conditions, or acts of war or acts of God.

Warranty claims cannot be made where the serial number on the Product has been altered, removed or cannot be confirmed. Refurbished or reconditioned or resold Products are not eligible for warranty service.

No person or company is authorized to make any warranties other as provided herein. THIS LIMITED WARRANTY IS THE SOLE AND EXCLUSIVE WARRANTY PROVIDED BY ER IN CONNECTION WITH THE PRODUCT AND IS, WHERE PERMITTED BY LAW, IN LIEU OF ALL OTHER WARRANTIES, GUARANTEES, REPRESENTATIONS, OBLIGATIONS AND LIABILITIES, EXPRESS OR IMPLIED, STATUTORY OR OTHERWISE IN CONNECTION WITH THE PRODUCT OR ITS PERFORMANCE, INCLUDING WITHOUT RESTRICTION, ANY IMPLIED WARRANTY OR CONDITION OF QUALITY, MERCHANTABILITY, FITNESS FOR A PARTICULAR PURPOSE OR NON-INFRINGEMENT. ANY IMPLIED

WARRANTY OF MERCHANTABILITY OR FITNESS FOR A PARTICULAR PURPOSE TO THE EXTENT REQUIRED UNDER APPLICABLE LAW TO APPLY TO THE PRODUCT SHALL BE LIMITED IN DURATION TO THE PERIOD STIPULATED UNDER THIS LIMITED WARRANTY. IN NO EVENT WILL ER BE LIABLE FOR ANY SPECIAL, INDIRECT, INCIDENTAL, PUNITIVE OR CONSEQUENTIAL DAMAGES, LOSSES, OR EXPENSES HOWEVER CAUSED.

IN THE EVENT THE ABOVE REMEDIES FAIL, OR UNDER ANY OTHER THEORIES OF RECOVERY, ER's AGGREGATE LIABILITY, IF ANY, FOR DAMAGES, LOSS OR OTHERWISE, SHALL NOT EXCEED THE PURCHASE PRICE PAID TO ER FOR THE PRODUCT. This warranty gives you specific legal rights, which may vary from state to state.

Evolution Robotics, Inc.
1055 E. Colorado Blvd.
Pasadena, CA 91106

Notice: This device complies with Part 15 of the FCC Rules. Operation is subject to the following two conditions: (1) This device may not cause harmful interference, and (2) this device must accept any interference received, including interference that may cause undesired operation.



Model Number 5200
www.mintcleaner.com

©2011 Evolution Robotics, Inc. All rights reserved. Evolution Robotics, the Evolution Robotics logo, Northstar, and Mint Plus are trademarks of Evolution Robotics, Inc. All other trademarks are the property of their respective owners. Reproduction in any manner whatsoever without the written permission of Evolution Robotics, Inc. is strictly forbidden.

US Patent Numbers. 7,148,458, 7,720,554, D625059, D625060, D625477, D625062, D629827. Other patents pending.