

# 13.56MHz Read/Write Board

User Guide : Version 1.20

FCC ID: OCTOEM-MSR2

Changes or modifications not expressly approved by id Systems Ltd could void the users authority to operate the equipment.

## **1 OVERVIEW**

- 1.1 Introduction
- 1.2 Scope of this guide
- 1.3 Product overview
- 1.4 Supporting products
- 1.5 Product range

## **2 USING THE BOARD**

- 2.1 Connecting to a board
- 2.2 Processor
- 2.3 Serial interface
- 2.4 LED indicators
- 2.5 Antenna
- 2.6 Read/write ranges
- 2.7 Mechanical
- 2.8 Miscellaneous

## **3 id SYSTEMS**

Appendix A – Board dimensions

# Using this Product



**Please complete and return the Product Registration Form at the back of this guide to ensure that you receive product support and information regarding updates.**

## WARNING

This product provides powerful features that allows the contents of Radio Frequency Identification (RFID) tags to be inspected, altered and (in some cases) permanently locked. It is the responsibility of the user to ensure that they are fully conversant with the wide range of features that are offered by tags supported by this product. No responsibility can or will be accepted by id Systems Ltd for any tags that are corrupted or permanently locked through direct or indirect use of this product.

It is not the purpose of this guide to provide an overview of the features of each type of tag supported by this product; the user is referred to the corresponding data sheets available from the appropriate tag manufacturer.

## WARRANTIES

id Systems Ltd makes no warranty of any kind with regard to the material contained in this document, including, but not limited to, implied warranties of merchantability and fitness for a particular purpose.

id Systems Ltd reserve the right to make changes without notice in the specifications and materials contained herein, and shall not be responsible for any damages (including consequences caused by reliance on the materials presented), including but not limited to typographic or arithmetic policy.

## RESTRICTIONS

This document contains proprietary information which is protected by copyright. All rights are reserved. No part of this document may be reproduced or transmitted in any form or by any means, electronic or mechanical, including photocopying, recording, or information storage and retrieval systems, without the prior written consent of id Systems Ltd.

## PRODUCT WARRANTY

This product is warranted against defects in materials and workmanship, under normal use and service, for one year from the date of purchase in accordance with id Systems' Standard Terms and Conditions. All goods returned under this warranty must be as new and not modified in any manner. Under such conditions id Systems' sole responsibility shall be, at its option, to either repair or replace such defective products. However, under no circumstances shall id Systems be liable for any consequential direct or indirect loss of revenue or profit, caused by failure of the product.

If this product requires repair, whether covered by the warranty or not, please contact the dealer or distributor from whom it was purchased.

© Copyright id Systems Ltd, 1999 : All rights reserved.

The use of all registered trademarks is acknowledged.

## 1.1 Introduction

id Systems' product range includes high performance hand-held units, computer interfaces and OEM boards, capable of reading from and writing to a wide range of Radio Frequency Identification (RFID) tags and smart labels, operating at low (125/134kHz) and high (13.56MHz) frequencies. The OEM board described in this guide supports high frequency tags and smart labels from OMRON, Philips Semiconductors (I.CODE), Texas Instruments (Tag-it) and Gemplus (FOLIO70), and is specifically designed to operate with a remote (deported) antenna.

Product features include:

- Read/write support for tags and smart labels from OMRON, Philips (I.CODE), Texas (Tag-it) and Gemplus (FOLIO70);
- Operates with a remote antenna, allowing a separation of up to 1m between a board and its associated antenna;
- In System Programmability (ISP) provides powerful capabilities for upgrading firmware for enhanced functionality and support for new tag types;
- Single supply operation (+5V) at low current (150mA when reading);
- Digital control of board power supply (board on/off);
- Low power modes, with board wake-up on external digital command or serial activity;
- Serial interface (at RS232 or TTL levels) with tri-state serial TTL buffer for total isolation within embedded applications;
- Powerful serial protocol, including optional direct ASCII output of tag data on successful read;
- Two software controlled digital outputs for LEDs (on or off board);
- I<sup>2</sup>C port for interfacing with external hardware (not supported in firmware);
- Small board size (approximately 52x70x13mm) with EMI/RFI screens fitted.

The OEM board provides a state of the art solution suitable for OEMs and System Integrators requiring powerful yet cost-effective capabilities for reading from and writing to all leading 13.56MHz tags and smart labels. The board may be used as a stand-alone component, or as part of a Basic or Enhanced OEM module, to provide additional facilities for demanding embedded applications.

Remote antennas allow up to 1m separation between an OEM board and its associated antenna; in addition, this approach offers decreased sensitivity to the antennas' immediate surrounding environment, including electrical noise, metal and capacitive effects.

The use of an advanced In System Programmable (ISP) component allows firmware to be readily and conveniently upgraded or modified to support new tags, or to provide enhanced functionality, without hardware changes.

Low operating current, and a number of low power modes (including wake-up on external digital command) make this board ideally suited for embedded applications.

## 1.2 Scope of this guide

This guide describes the features and capabilities of a 13.56MHz OEM board for 13.56MHz tags and smart labels, including those from OMRON, Philips Semiconductors (I.CODE), Texas Instruments (Tag-it) and Gemplus (FOLIO70), and describes all aspects of the hardware. This guide should be read in conjunction with the corresponding document that describes the RS232 serial protocol (acc-232).

## 1.3 Product overview

Features of the OEM board are summarised in Figure 1, which shows the board as viewed from above and below.

Features include:

- **Powerful Processor**

The OEM board uses a powerful Atmel AVR RISC processor to control all board functionality.

- **In-System Programmability**

An on-board programming interface provides powerful capabilities for future upgrading of board firmware for enhanced functionality.

- **LED Indicators**

Two software controlled LEDs can be used to indicate power-on and status information, controlled via application software.

- **Serial Interface**

An RS232 or TTL compatible serial interface allows data to be transferred to and from the OEM board.

- **External Antenna**

Provision is made for an external antenna to be connected directly to the board; this may be located up to 1m away.

- **Powerful Firmware**

The board supports read/write functionality for I.CODE tags and Tag-it tags and smart labels, and provides a powerful serial protocol for board set-up, data exchange and status monitoring.

## 1.4 Supporting Products

Please note that a number of additional products are also available to support this OEM board (Table 1).

Order Code	Description
sw-api	API/DLL software for rapid development of application software
acc-232	RS232 serial protocol guide
ant-hf2/3	Remote PCB antennas
sw-sdk	Software Developer's Kit
sw-oem	OEM board test software
ev-oem	OEM Developer's Pack

Table 1 – Support products

## 1.5 Product range

This product forms part of an extensive range of low (125/134kHz) and high (13.56MHz) frequency products, which currently includes support for the following tags and smart labels, in hand-held units, computer interfaces, and OEM boards:

- **Low Frequency**
  - ◊ **ASK tags from:**  
EM Marin (H4001/2/3/5, v4050 and v4066), Gemplus (Gemfly), Metget (all standard products), Philips (hitag1, hitag2, PCF7930, PCF7931 and PCF79736), Sokymat (Magic, Nova, Titan, Unique and Zodiac), Temic (e5530 and e5550).
  - ◊ **FSK tags from:**  
Texas Instruments (TIRIS)
  - ◊ **PSK tags from:**  
AEG/Trovan, Datamars and EM Marin
- **High Frequency**
  - ◊ **Tags from:**  
Gemplus (Gemwave ARI010 and ARI040; FOLIO70), OMRON, Philips Semiconductors (I.CODE), Texas Instruments (Tag-it)

# Using the Board

# 2

## 2.1 Connecting to a board

The board requires a source of external power (+ 5V at 150mA), and an antenna. Power should be connected to J1 pin 2 (+ 5V) and pin 10 (0V). The supply should be 5V +/- 0.2V with less than 50mV ripple.

Connector J1 is part type Molex 53261-1090 (the mating part type is Molex 51021-1000).

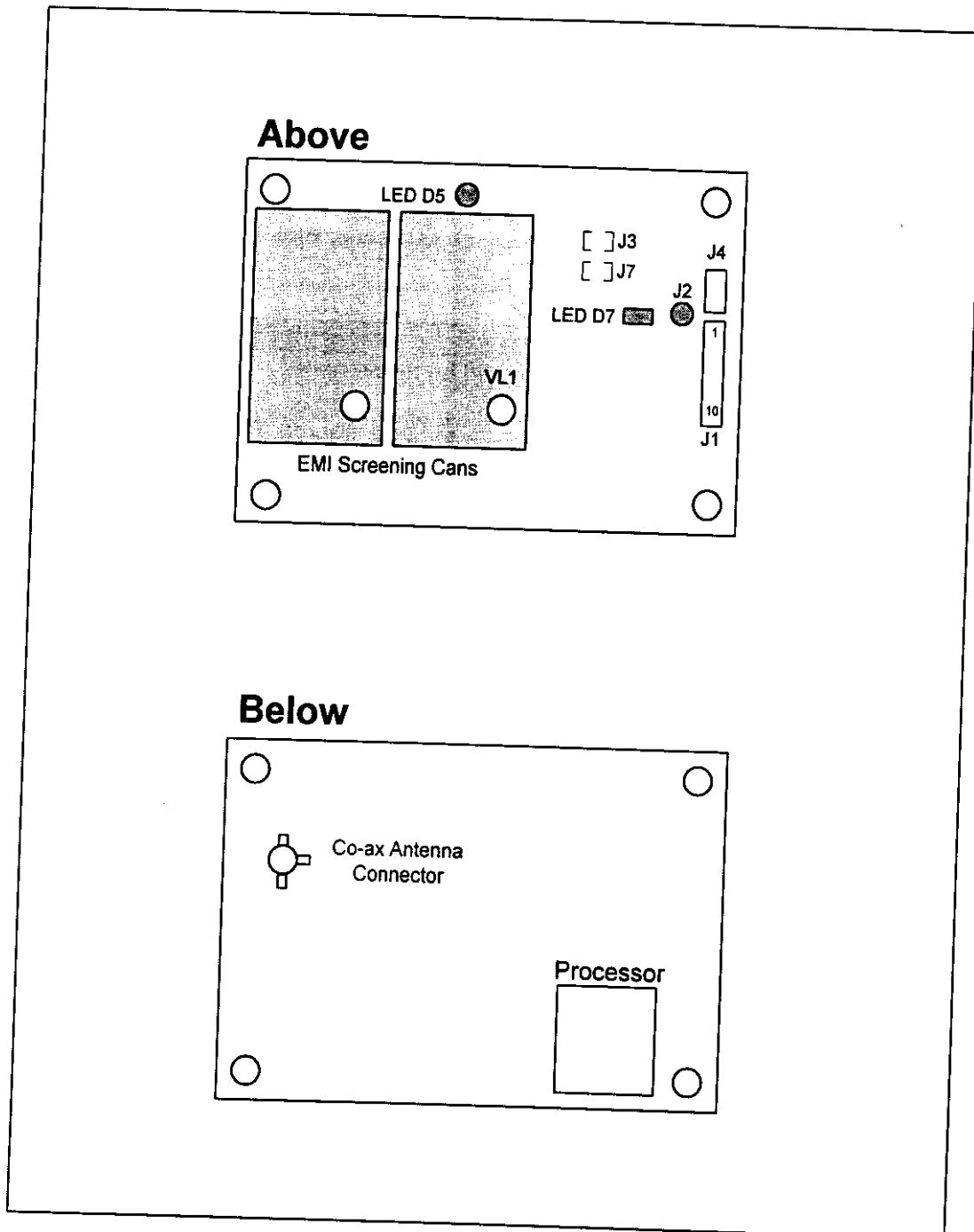

Figure 1 – OEM board features

# Using the Board

# 2



There is no protection against over voltage on the board; therefore it is the responsibility of the user to ensure that the correct power supply is applied.

A power on control signal (DTR) is provided on J1 pin 4. When this pin is pulled high (+5V) the board will power up. When pulled low (0V) the board is in a powered down state, where it draws less than 100 $\mu$ A. In this state the TTL serial interface signals are high impedance.

The board will enter a low power sleep mode after a period of inactivity on the serial interface. Wake up is achieved by one of two methods:

- Through transmission of a serial command to the board;
- By pulling J1 pin 8 low (0V) for longer than 250mS, which will cause the board to wake-up and attempt a tag read, returning ASCII data via the serial interface. Keeping this pin low will place the board in a continuous read mode (please see our serial protocol guide for configuration of this option).

Pin	Signal	Description
1	RI	No connection should be made here
2	5V	+ 5V
3	RXD	Serial data input from external source (RS232 or TTL)
4	DTR	Board power on from external source (TTL active H)
5	TXD	Serial data output to external source (RS232 or TTL)
6	DSR	Not implemented
7	DCD	Not implemented
8	RTS	Wake-Up signal from external source (TTL active L)
9	BAT	No connection should be made here
10	GND	0V

Table 2 – Pin allocation of connector J1

An external antenna is attached via the co-axial connector on the rear of the board (see section 2.5).

## 2.2 Processor

The board uses a powerful Atmel AVR processor to control all functionality. An In System Programming (ISP) capability is available at J4, for downloading firmware. This is currently only available for use by id Systems.

## 2.3 Serial interface

Connector J1 provides access to a three wire RS232 or TTL compatible serial interface via pins 3, 5 and 10. Standard configuration is an RS232 interface; please contact id Systems if you wish to change this to a TTL interface.

The default serial parameters are 9600 baud, 8 data bits, no parity, 1 stop bit. An optional baud rate of 19200 may be implemented by linking solder pad J3. The serial protocol that allows communication with the board is described in the corresponding guide (acc-232).



## 2.4 LED indicators

Two LED indicators (LED D5 and LED D7) are provided. D5 is a standard 3mm LED which can be soldered directly on the board, or via two wires for mounting off-board. D7 is either a 0805 SMD LED for board mounting, or a standard 3mm LED connected to J2 for external mounting; it is recommended that either D7 or J2 is used, not both. D5 and D7 are controlled using the serial command *CL\_SetIO*.

## 2.5 Antenna

A number of remote antennas are available from id Systems to support this OEM board, and we recommend the use of these antennas to ensure optimum read/write ranges are achieved. Remote antennas are supplied pre-tuned for optimal performance; please do not make adjustments.

The maximum capacitance of the antenna connecting lead should not exceed 100pF if quoted range performance is to be maintained.

## 2.6 Read/write ranges

Typical read/write ranges are summarised in Table 3. Range figures assume optimum orientation of the tag and reader's antennas, in an EMI/RFI clean environment, with no metallic objects nearby.

Please note that read/write range will change according to antenna size and quality factor. The ranges summarised below are typical for an ant-hf2 antenna, with tags the same size as ISO credit card format.

	Antenna	Tag
Read range (mm)	5 to 80	5 to 80
Write range (mm)	10 to 70	15 to 60

Table 3 - Typical read/write ranges

## 2.7 Mechanical

Mechanical data for the board is provided in Appendix A. Four 2.8mm mounting holes are provided in the corners of the board, suitable for 2.5mm diameter screws. Please ensure that insulating spacers are used for mounting.

## 2.8 Miscellaneous

There are a number of differences between our existing range of RFID OEM boards, and this high frequency board. These are:

- The buzzer command is not supported (there is no buzzer on the board!);
- There is no generic write command (the second option of the *RF\_Write Block* command);
- Autobaud is not supported (the baud rate is fixed at 9600, but other options are available; please consult id Systems for further information);
- Configuration 'Text len' parameter is ignored (*CL\_SetConfig* command);
- The commands *CL\_MemRead* and *CL\_MemWrite* are not supported;
- *CFG\_PulseOutput* and *CFG\_Continuous* options are not supported.

Radio Frequency Identification (RFID) is a powerful and versatile technology that allows items to be identified, tracked and managed, in an extraordinarily diverse range of applications and environments.

id Systems is dedicated to the development of state of the art RFID systems for global markets. We combine innovation, technical excellence and quality in the development of a broad range of novel products and systems based on RFID technology.

We provide:

- Innovative RFID products, ranging from demonstration systems and boards suitable for system integration, to hand-held readers and turnkey applications for industry.
- Comprehensive consultancy services based on expertise in all aspects of RFID, allowing us to provide effective support to organisations wishing to benefit from this powerful technology.
- Software support for most RFID technologies, including powerful system integration libraries and tools.
- Customised RFID reader hardware and high performance antenna arrangements, optimised for specific requirements.

Our expertise and product range allows us to provide powerful and cost effective solutions to identification problems.

We have an excellent appreciation of application requirements, and a first principles understanding of RFID technology. This special combination of skills and expertise allows incisive problem solving across the diverse range of environments where RFID may be applied, bringing measurable and sustainable competitive advantage to business operations world-wide.

**id SYSTEMS Ltd**

Rutherford House, Manchester Science Park  
Manchester M15 6SZ, UK

**tel** +44 (0)161 232 1000 **fax** +44 (0)161 232 1010

**e-mail** [info@idsys.co.uk](mailto:info@idsys.co.uk) **web** <http://www.idsys.co.uk>

## Board Dimensions

Reader Board

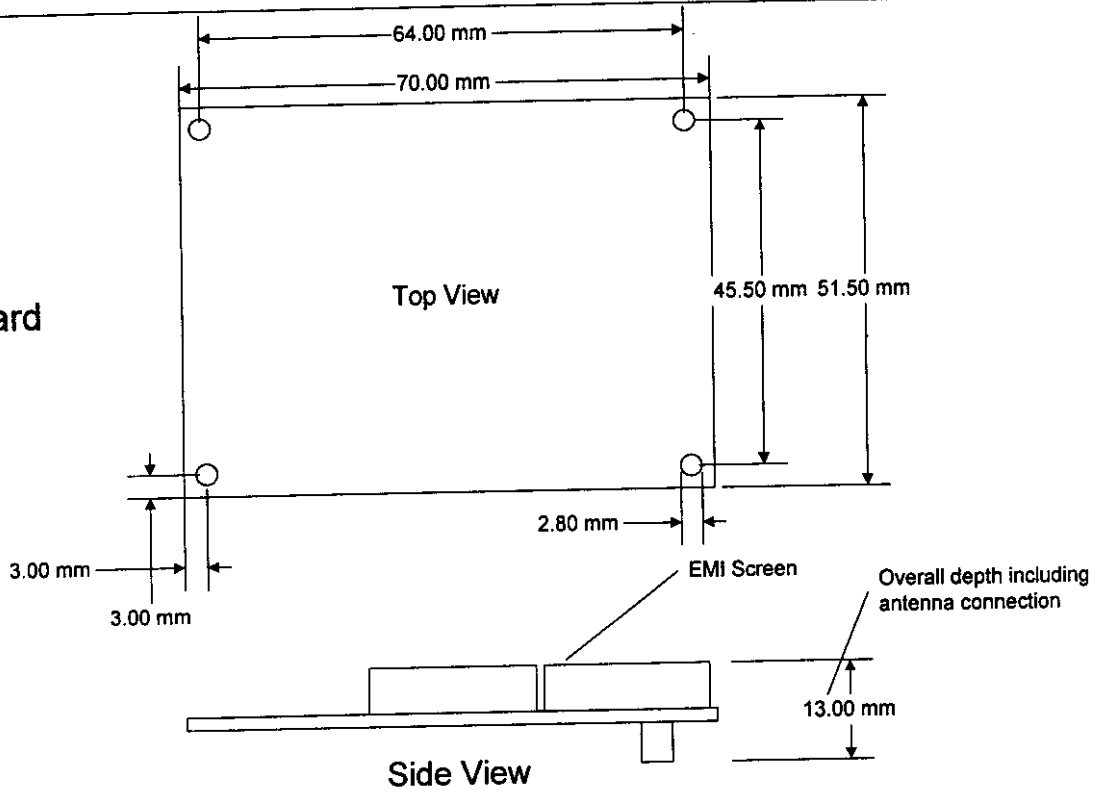

Antenna

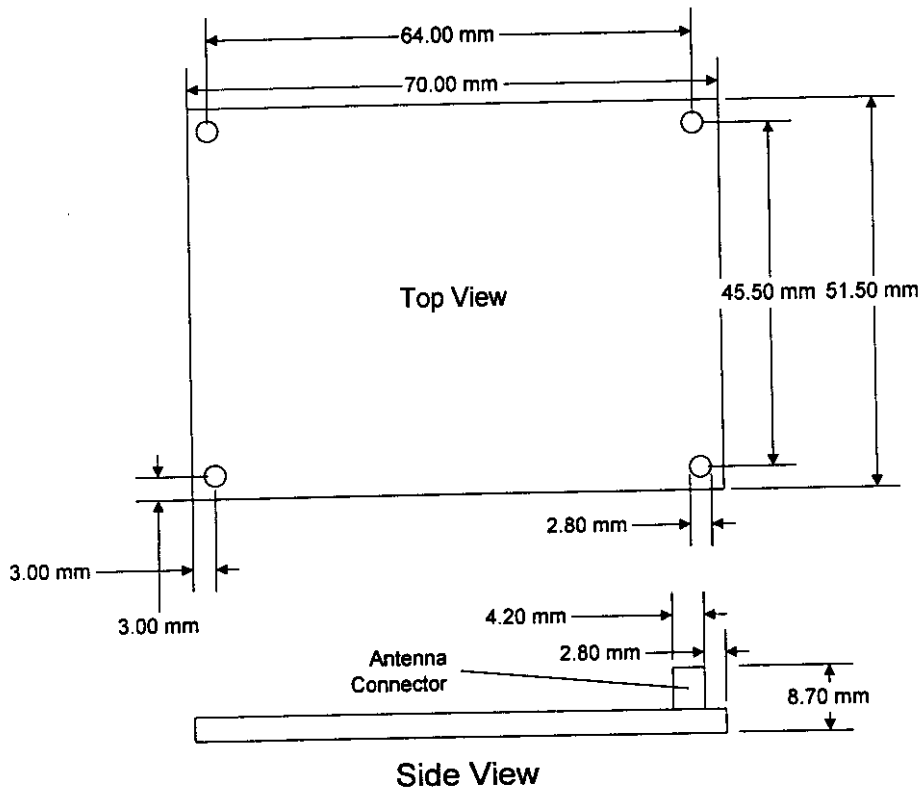

# Product Registration Form



Please complete the information below and return by mail or fax to id Systems.

First Name

Surname

Title / Position

Company Name

Address

Postcode

Country

Telephone

Facsimile

Email Address

Product

Serial Number  Date  /  /

Do you wish to be kept informed of new product releases? Yes  No

**id SYSTEMS Ltd**

Rutherford House, Manchester Science Park  
Manchester M15 6SZ, UK

tel +44 (0)161 232 1000 fax +44 (0)161 232 1010

e-mail [info@idsys.co.uk](mailto:info@idsys.co.uk) web <http://www.idsys.co.uk>

