

OPERATOR'S MANUAL

INCLUDING: OPERATION, INSTALLATION & MAINTENANCE

66602X-X

RELEASED: 6-10-93
REVISED: 6-21-10
(REV.H) IPP/PSE

1/4" DIAPHRAGM PUMP 1:1 RATIO (NON-METALLIC)



**READ THIS MANUAL CAREFULLY BEFORE INSTALLING,
OPERATING OR SERVICING THIS EQUIPMENT.**

THIS MANUAL COVERS THE FOLLOWING MODELS

MODEL	TH'D	CHECKTYPE	WETTED MATERIAL
666023,J,H,L*-XXX	NPT	FLAT	POLYPROPYLENE
666026,M,N,P*-XXX	NPT	FLAT	GROUNDABLE ACETAL

* J,H,L,M,N,P Represent Inlet and Outlet Options, refer to page 3 for more information.

SERVICE KITS

Refer to Service Kit Chart on page 3 to match pump material with Service Kits offered. The "X" represents a variable digit of the Model No.
637273-XXX for Pump Rebuild. (Model digits 7,8,9)
637274-XX for Check Valve Replacement. (Model digits 7,9)
637275-XX for Diaphragm and Air Section repair. (Model digits 8,9)
637276 for Pre-assembled Replacement Air Valve Section. (Fig.2)

PUMP DATA

MODELS - See Model Description Chart for "-XXX" on page 3.

PUMP TYPE - Non-Metallic Air Operated Double Diaphragm

MATERIAL - See Model Description Chart on page 3.

WEIGHT LBS. - Polypropylene 3.6 (1.63 kgs)
- Groundable Acetal 4.1 (1.86 kgs)

MAXIMUM AIR INLET PRESSURE - 100 p.s.i.g. (6.9 bar)

MINIMUM AIR INLET PRESSURE - 20 p.s.i.g. (1.4 bar)

MAXIMUM OUTLET PRESSURE - 100 p.s.i.g. (6.9 bar)

MAXIMUM FLOW RATE - 5 g.p.m. (18.9 Liters)

MAXIMUM SUCTION LIFT - 20 Ft. (Water)

MAXIMUM OUTPUT PER CYCLE - .014 Gallons (53 cc's)

MAXIMUM PARTICLE SIZE - 1/32" dia.

MAXIMUM TEMP. LIMITS -

Polypropylene 35°F to 120°F

Groundable Acetal 10°F to 150°F

GROUNDABLE - 666026-XXX Models Only

DIMENSIONAL DATA - See page 8.

NOISE LEVEL* - 59.8 db(A) @ 70 psi, 60 cycles per minute.

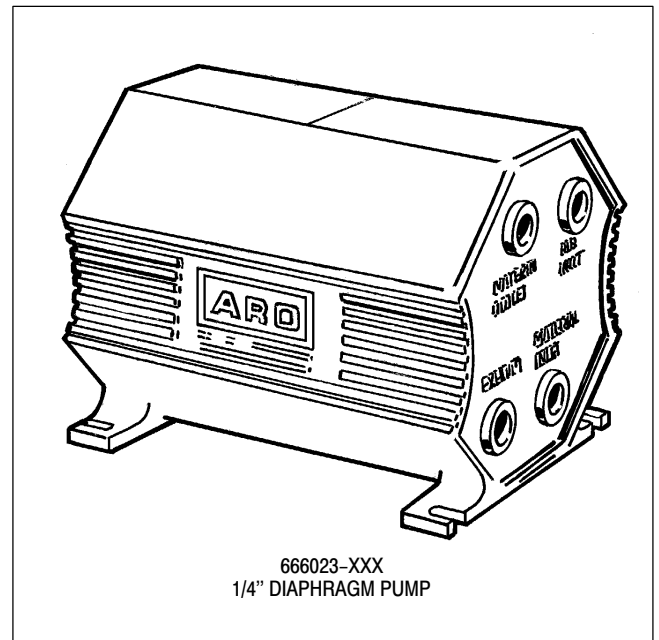

666023-XXX
1/4" DIAPHRAGM PUMP

* The pump sound pressure levels published here have been updated to an Equivalent Continuous Sound Level (L_{Aeq}) to meet the intent of ANSI S1.13-1971, CAGI-PNEUROP S5.1 using four microphone locations.

GENERAL DESCRIPTION

The ARO Diaphragm Pump offers high volume delivery even at low air pressures, easy self priming, the ability to pump various viscosity materials and the ability to pass solids (as stated in the chart above). The pump is designed to correspond to the needs of the user by offering a variety of wetted parts configurations to handle almost any application. Refer to the model and option chart on page 3.

Model 666026-XXX: The Acetal material used in this pump contains Stainless Steel fibers, it's conductivity allows it to be connected to a suitable ground, a ground screw is provided for this.

NOTICE: All possible options are shown in the chart on page 3 however certain combinations may not be recommended, consult a representative or the factory if you have questions concerning availability.

INGERSOLL RAND COMPANY LTD

209 NORTH MAIN STREET - BRYAN, OHIO 43506

(800) 495-0276 • FAX(800) 892-6276

© 2010

www.ingersollrandproducts.com

ARO

IR Ingersoll Rand
Industrial Technologies

OPERATING AND SAFETY PRECAUTIONS

- ◇ Read and heed all Warnings, Cautions, and Safety Precautions before operating this pump.
- ◇ Use only genuine ARO replacement parts to assure compatible pressure rating and longest service life.

⚠ WARNING EXCESSIVE AIR PRESSURE. Can cause pump damage, personal injury or property damage.

- Do not exceed the maximum inlet air pressure as stated on the pump model plate.

⚠ WARNING STATIC SPARK. Can ignite flammable material and vapors resulting in fire or explosion causing severe personal injury or property damage.

- The pumping system and object being sprayed must be grounded when it is pumping, flushing, recirculating or spraying flammable materials such as paints, solvents, lacquers, etc. or used in a location where surrounding atmosphere is conducive to spontaneous combustion.
- 666026-XXX Groundable Acetal pumps: Use the pump grounding screw provided. A screw terminal is provided on the Fluid Cap (Remove the cover to gain access). Connect a 12 ga. (min.) wire (66885-1 Kit is available) to a good earth ground source.
- Ground dispensing valve or device, containers, hoses and any object to which material is being pumped.
- After grounding, periodically verify continuity of electrical path to ground. Test with an ohmmeter from each component (e.g., hoses, pump, clamps, container, spray gun, etc.) to ground to insure continuity. Ohmmeter should show 10 ohms or less.
- Secure pump, connections and all contact points to avoid vibration and generation of contact or static spark.
- Consult local building codes and electrical codes for specific grounding requirements.

⚠ WARNING DIAPHRAGM RUPTURE. Can cause serious injury or property damage. Material can be forced out of the air exhaust muffler.

- Pipe the exhaust to a safe remote location when pumping hazardous or inflammable materials.
- Use a grounded 1/4" min. I.D. hose between the the pump and the muffler.

⚠ WARNING HAZARDOUS PRESSURE. Can result in serious injury or property damage. Do not service or clean pump, hoses or dispensing valve while the system is pressurized.

- Disconnect air supply line and relieve pressure from the system by opening dispensing valve or device and/or carefully and slowly loosening and removing outlet hose or piping from pump.

⚠ WARNING HAZARDOUS MATERIALS. Can cause serious injury or property damage. Do not attempt to return a pump to the factory or service center that contains hazardous material. Safe handling practices must comply with local and national laws and safety code requirements.

- Obtain Material Safety Data Sheets on all materials from the supplier for proper handling instructions.

◇ **SAFETY PRECAUTIONS (GENERAL)** should include:

- Use of static wire hoses.
- Submersion of outlet hose end, dispensing valve or device within material being dispensed whenever possible. (Avoid free streaming of material being dispensed.)
- Proper ventilation of area away from heat, open flames and sparks.
- Keeping inflammables away from heat, open flames and sparks.
- Keeping containers closed when not in use.
- Be sure material hoses and other components are able to withstand fluid pressures developed by this pump. Check all hoses for damage or wear. Be certain dispensing device is clean and in proper working condition.

⚠ CAUTION Verify the chemical compatibility of the pump wetted parts and the substance being pumped, flushed or recirculated. Chemical compatibility may change with temperature and concentration of the chemical(s) within the substances being pumped, flushed or circulated. Consult ARO Form No. 8677-P, Fluid Compatibility Guide, for information on chemical compatibility.

⚠ CAUTION Maximum temperatures are based on mechanical stress only. Certain chemicals will significantly reduce maximum safe operating temperature. Consult Fluid Compatibility Guide for chemical compatibility and temperature limits.

- Temperature Limits:

Polypropylene 35° F to 120° F
Groundable Acetal 10° F to 150° F.

⚠ CAUTION Be certain all operators of this equipment have been trained for safe working practices, understand it's limitations, and wear safety goggles/equipment when required.

⚠ CAUTION Do not use the pump for the structural support of the piping system. Be certain the system components are properly supported to prevent stress on the pump parts.

- Suction and discharge connections should be flexible connections (such as hose), not rigid piped, and should be compatible with the substance being pumped.

⚠ CAUTION Prevent unnecessary damage to the pump. Do not allow pump to operate when out of material for long periods of time.

- Disconnect air line from pump when system sits idle for long periods of time.

⚠ WARNING = Hazards or unsafe practices which could result in severe personal injury, death or substantial property damage.

⚠ CAUTION = Hazards or unsafe practices which could result in minor personal injury, product or property damage.

NOTICE = Important installation, operation or maintenance information.

MODEL DESCRIPTION CHART

BASIC MODEL NO.

6660 X X

BODY MATERIAL, INLET/OUTLET OPTION

23 POLYPROPYLENE, (1)INLET/(1)OUTLET
 26 GROUNDABLE ACETAL, (1)INLET/(1)OUTLET
 2J POLYPROPYLENE, (1)INLET/(2)OUTLET
 2H GROUNDABLE ACETAL, (1)INLET/(2)OUTLET
 2L POLYPROPYLENE, (2)INLET/(1)OUTLET
 2M GROUNDABLE ACETAL, (2)INLET/(1)OUTLET
 2N POLYPROPYLENE, (2)INLET/(2)OUTLET
 2P GROUNDABLE ACETAL, (2)INLET/(2)OUTLET

FLUID SECTION MATERIAL OPTIONS

- X X X

CHECK VALVE SEAT MATERIAL

3 POLYPROPYLENE
 6 ACETAL

CHECK MATERIAL

4 PTFE

DIAPHRAGM/O-RING MATERIAL

4 PTFE/T.F.E
 D PTFE/FLOURAZ®
 E SANTOPRENE®/FLUORAZ

AIR AND LUBE REQUIREMENTS

⚠ WARNING EXCESSIVE AIR PRESSURE. Can cause pump damage, personal injury or property damage.

- A filter capable of filtering out particles larger than 50 microns should be used on the air supply. In most applications there is no lubrication required other than the "O"ring lubricant which is applied during assembly or repair.
- The pump can be rotated 360° to suit the application. It may be mounted upside down or on the wall with no effect on suction lift or operating efficiency. The filter and regulator need to be oriented in a normal vertical direction to function properly.
- Pipe plugs included for the material inlets, they can be switched to accommodate piping requirements however the fluid inlet must always be in the port closest to the mounting base.
- When lubricated air is necessary, supply the air lubricator with a good grade of SAE 90 wt. non-detergent oil and set the lubricator to a rate not to exceed one drop per minute.

INSTALLATION

- **NOTICE:** Re-torque fasteners prior to use. Refer to page step #22 on page 7 for information.
- Apply PTFE tape or pipe sealant to threads upon assembly to prevent leakage.
- Secure the diaphragm pump legs to a suitable surface to insure against damage by vibration.
- To avoid problems install a particle fluid filter to screen out foreign matter 1/32" or larger in diameter.
- The pump is not recommended for submerged applications.
- When the diaphragm pump is used in a forced-feed (flooded inlet) situation it is recommended that a "Check Valve" be installed at the air inlet.

OPERATING INSTRUCTIONS

- Always flush the pump with a solvent compatible with the material being pumped if the material being pumped is subject to "setting up" when not in use for a period of time.
- Disconnect the air supply from the pump if it is to be inactive for a few hours.

• Viton® and Hytrel® are registered trademarks of the DuPont Company • Kynar® is a registered trademark of Penwalt Corp • Fluoraz® is a registered trademark of Greene, Tweed & Co. Inc.
 • Santoprene® is a registered trademark of Monsanto Company, licensed to Advanced Elastomer Systems, L.P. • Key-Lube® is a registered trademark of Key Industries

- The outlet material volume is governed not only by the air supply but also by the material supply available at the inlet. The material-supply tubing should not be too small or restrictive. Be sure not to use hose which might collapse.

MAINTENANCE

Refer to the part list pg. 4 for Service Kit Information, parts view on pg. 5. and Repair Procedures on pgs 6 and 7.

- Certain ARO "Smart Parts" are indicated which should be available for fast repair and reduction of down time.
- Provide a clean work surface to protect sensitive internal moving parts from contamination from dirt and foreign matter during service disassembly and reassembly.
- Keep good records of service activity and include pump in preventive maintenance program.

SERVICE KITS

66602X-	CHECK VALVE	DIAPHRAGM & AIR SECTION	REBUILD KIT
-344	637274-34	637275-44	637273-344
-34D	637274-3D	637275-4D	637273-34D
-34E	637274-3E	637275-4E	637273-34E
-644	637274-64	637275-44	637273-644
-64D	637274-6D	637275-4D	637273-64D
-64E	637274-6E	637275-4E	637273-64E

PARTS LIST

Refer to the Kit Selection Chart page 3 for proper “-XXX” for your model.

SERVICE KITS	KIT NUMBER	THESE ITEMS ARE INCLUDED IN THE KITS																
CHECK VALVE KIT	637274-XX		19	33		71												
DIAPHRAGM & AIR VALVE KIT	637275-XX	7	19	33	64		102	110			119	132		137	138	144	146	147
COMPLETE REBUILD KIT	637273-XXX	7	19	33	64	71	102	110			119	132		137	138	144	146	147
AIR VALVE REPLACEMENT ASM.	637276						102	111	118		132	135	137		142	145	146	147

Keylube packet 93706-1 is included with all kits.

DIAPHRAGM OPTIONS

66602X-XXX	“7”		“64”		“19”		“33”	
	DIAPHRAGM (2)	[MTL]	“O”ring (2) 79mm X 4 mm	[MTL]	“O”ring (8) 1-1/8” O.D.	[MTL]	“O”ring (4) 3/4” O.D.	[MTL]
-XX4	■93898	[T]	■93947	[B]	■93831	[T]	■93830	[T]
-XXD	■93898	[T]	■93947	[B]	■93933	[F]	■93932	[F]
-XXE	■93808	[SP]	---	--	■93933	[F]	■93932	[F]

COMMON PARTS

ITEM	DESCRIPTION (SIZE IN INCHES)	QTY	POLYPROPYLENE 666023,J,L,N		GROUNDABLE 666026,H,M,P	
			PART NO.	[MTL]	PART NO.	[MTL]
<input type="checkbox"/> 1	Rod (2-13/16 Long)	(1)	93916	[S]	93916	[S]
<input type="checkbox"/> 5	Washer (1-3/4 O.D.)	(2)	93915	[SS]	93915	[SS]
<input type="checkbox"/> 6	Diaphragm Nut (1/4-20)	(2)	93810-1	[P]	93810-2	[D]
<input type="checkbox"/> 16	Manifold	(4)	93817-1	[P]	93817-2	[G]
<input type="checkbox"/> 36	Manifold Tube	(○)	93813-1	[P]	93813-2	[D]
37	Manifold Plug	(○)	93941-1	[P]	93941-2	[D]
43	Ground Screw (10-32 x 1/4) Not Shown	(1)	-----	--	93005	[S]
62	Nut (1/4-20)	(6)	93828	[SS]	93828	[SS]
63	Pipe Plug (1/4-18) Not Shown	(2)	93832-1	[P]	93832-2	[D]
<input type="checkbox"/> 65	Fluid Cap, W/AIR INLET	(1)	93812-1	[P]	93812-2	[G]
<input type="checkbox"/> 66	Fluid Cap	(1)	93811-1	[P]	93811-2	[G]
<input type="checkbox"/> 68	Air Cap, Right (w / Groove ○)	(1)	93804	[P]	93804	[P]
<input type="checkbox"/> 69	Air Cap, Left (w / Tongue ◇)	(1)	93805	[P]	93805	[P]
71	Check Asm.: Seat, Disc, Stop	(4)	■66973-1	[P]	■66973-2	[D]
72	Cover, Right	(1)	93816-2	[P]	93816-2	[P]
73	Cover, Left	(1)	93816-1	[P]	93816-1	[P]
131	Bolt (1/4-20 x 6.250)	(6)	93827	[SS]	93827	[SS]

MATERIAL CODE

[A]=Aluminum
 [B]=Buna “N”
 [D]=Acetal (Orange)
 [F]=Fluoraz
 [G]=Groundable Acetal (Dk Gray)
 [K]=Kraton
 [N]=Neoprene
 [P]=Polypropylene (Lt Gray)
 [R]=Ryton
 [S]=Steel
 [SP]=Santoprene
 [SS]=Stainless Steel
 [T]=PTFE
 [U]=Polyurethane
 *Refers to wetted parts only

PART NOTES

○ Manifold Qty's will be either 1 or 2 depending on the inlet/outlet option selected. (Refer to chart on page 3.)

■ These parts are available in Service Kits only, see the Service Kit Chart at the top of the page and on page 3.

“Smart Parts” keep these items on hand in addition to the Service Kits for fast repair and reduction of down time.

AIR SECTION PARTS

ITEM	DESCRIPTION (Size in Inches)	QTY	PART NO.	[MTL]	ITEM	DESCRIPTION (Size in Inches)	QTY	PART NO.	[MTL]
102	“O”Ring (7/8 O.D.)	(3)	■Y325-018	[B]	137	“O”Ring (1 O.D.)	(1)	■Y325-020	[B]
103	Bushing	(1)	93917	[D]	138	“O”Ring (13/16 O.D.)	(1)	■Y325-114	[B]
110	“U”Cup (13/16 O.D.)	(1)	■Y186-54	[B]	142	Screw (#4-20)	(3)	93942	[SS]
<input type="checkbox"/> 111	Spool Asm.-(Incl'ds #110,#119,#138)	(1)	65438	[D]	144	“U”Cup (5/8 O.D.)	(2)	■Y186-45	[B]
<input type="checkbox"/> 118	Trip Rod Asm. - Includs (4) #119	(1)	65439	[D]	<input type="checkbox"/> 145	Minor Valve Block	(1)	93807	[R]
119	“O”Ring (5/8 O.D.)	(1)	■15066	[B]	146	“O”Ring (5/16 O.D.)	(2)	■Y325-008	[B]
132	Gasket	(1)	■93809	[K]	147	“O”Ring (7/16 O.D.)	(2)	■Y325-011	[B]
<input type="checkbox"/> 135	Valve Block	(1)	93806	[R]					

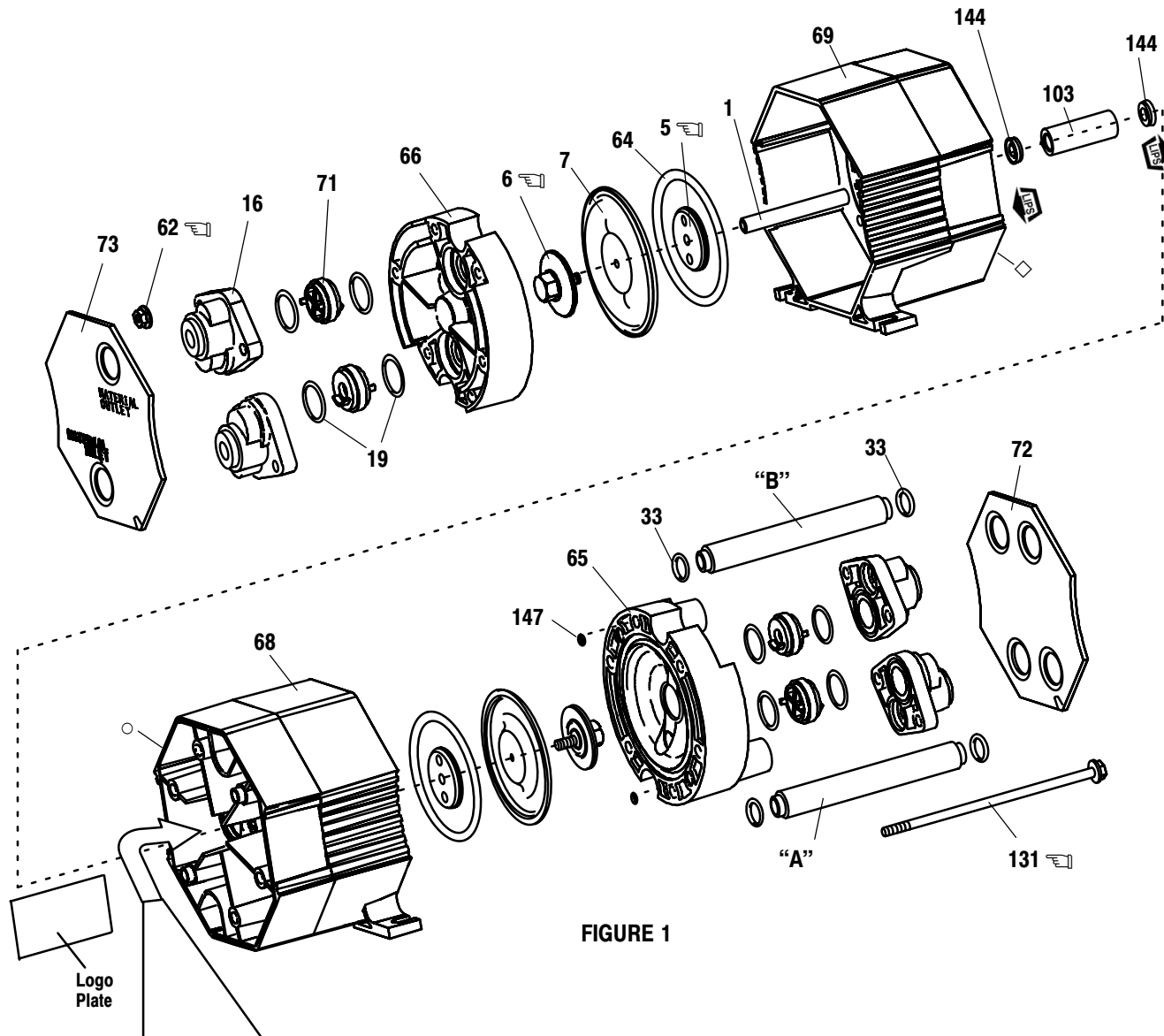

FIGURE 1

These parts are included in Air Valve Replacement Kit 637276.

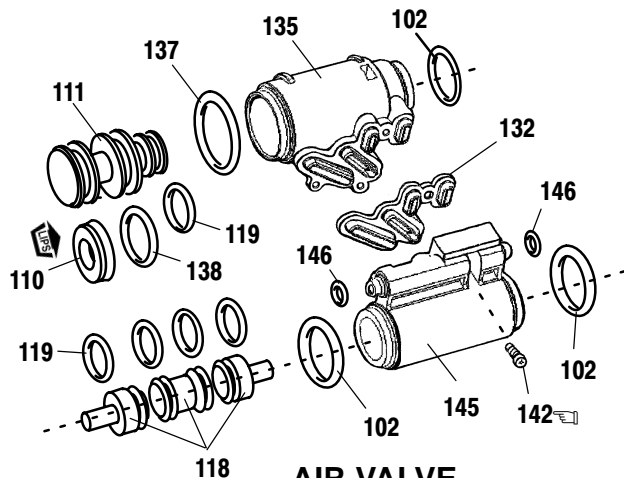

FIGURE 2

AIR VALVE
(SHOWN 2X SCALE)

INLET / OUTLET OPTIONS	MANIFOLD TUBE	
	"A"	"B"
SI / SO	36	36
SI / DO	36	37
DI / SO	37	36
DI / DO	37	37

TORQUE REQUIREMENTS

NOTE: DO NOT OVERTIGHTEN FASTENERS

- (6) / (5) Diaphragm nut / washer 75–85 in.lbs.
use Loctite #242, tighten together.
- (62) / (131) Manifold bolts / nuts 35–45 in.lbs.,
tighten together alternately & evenly, then re-torque.
- (142) Torque to 4–6 in.lbs.

LUBRICATION

Apply Keylube (93706-1) to all
"O"rings, "U" Cups & mating parts

PUMP DISASSEMBLY AND REASSEMBLY

GENERAL PUMP REPAIR NOTES:

- Tools needed to complete disassembly and repair.:
 - 7/16" Wrench, 9/16" Wrench, 7/16" Socket, 9/16" Socket, Spanner Wrench, Torque Wrench (measuring inch pounds), "O"ring Pick.
- Once the pump is disassembled, you have the opportunity to clean and inspect all parts for wear. Look for deep scratches on metallic surfaces, and nicks or cuts in "O"rings. Replace old parts with new ones as necessary.
- Take precautions to prevent cutting "O"rings upon installation.
- Lubricate "O"rings and "U" cups with Key-lube or equivalent. A packet of this lubricant is included in each Service Kit.
- Do not over-tighten fasteners, refer to torque specification block on view.
- Re-torque fasteners following restart.

Service Kits available. From your local distributor.
(Kits also include Keylube grease packet.)

- SERVICE KIT: 637273-XXX contains parts for a complete pump rebuild.
- SERVICE KIT: 637274-XX contains new check assemblies.
- SERVICE KIT: 637275-XX includes parts to rebuild the air motor and diaphragms.
- AIR VALVE REPLACEMENT KIT: 637276 includes a complete factory pre-assembled replacement air valve section.

PUMP DISASSEMBLY:

1. Place the pump on a flat workbench. Remove both cover plates and set them aside.
2. Using a 7/16-inch wrench, loosen the bolts that run through the pump and remove the six nuts. Pull the bolts through the pump body and set them aside.
3. The fluid caps and manifolds may fall free at this time. If not, grasp the fluid caps and separate them from the pump body.
4. The air inlet fluid cap has two small "O"rings at the air inlet and exhaust ports. Remove these with the "O"ring pick.
5. The manifold tubes may have pulled free of the pump when the fluid caps were removed, if not remove both tubes from the pump body.
6. Remove the "O"rings from the ends of each manifold tube.
7. If the manifolds did not fall free, separate them from the fluid caps at this time.
8. To remove the checks, it may be necessary to push a dowel through the fluid caps.
9. Use the pick to remove any "O"rings that remain in the manifold or fluid cap.
10. With the 9/16" socket and 9/16" wrench, loosen and remove either diaphragm nut. Gently pull the diaphragm away from the pump body.
NOTE: Models with PTFE diaphragms will have backup "O"rings.
11. Push the connecting rod through the pump body. Wrap the connecting rod in a shop rag and secure in a soft-jawed vise.
12. Remove the remaining diaphragm nut with a 9/16-inch wrench.
NOTE: Be careful not to mar the connecting rod surface during this step.
13. Using the 9/16" wrench and the spanner wrench, remove the backup washer from the diaphragm nut. This will allow you to separate

the diaphragm from the nut.

- NOTE: Be careful not to round the diaphragm nut during this step.
14. Pull apart the two air caps. The connecting rod bushing will fall free. If the air valve block asm. did not fall free, pull it from the air cap at this time.
 15. Use the "O"ring pick to remove the air cap seal.
 16. Use the pick to remove the U-cups and any "O"rings that may remain in the air caps.
 17. Remove the retaining screws and separate the valve block and minor valve block. Pull the piston from the minor valve block. Then remove all "O"rings using the pick. Gently push the spool from the valve block. A dowel may be needed to push out the spool.
NOTE: Be careful not to damage either part during this step.
 18. Use the pick to remove all "O"rings from the spool and the center gasket from the valve block.

PUMP REBUILD PROCEDURES: (rebuild by service kits)

For the 637273-XXX and 637275-XX Service Kits

AIR VALVE SECTION (Steps 1-6)

1. Install new "O"rings and U-cup on the spool and piston.
2. Lubricate the spool, piston and internal bores of the valve blocks.
3. Insert the piston into the minor valve block, being careful not to damage any "O"rings during this process. Now slide the spool into the valve block, inserting the small end first.
NOTE: There may be some resistance when installing the piston and spool, however you should not have to force the parts into place.
4. Install the shaped gasket into the minor valve block and push the major valve block into the minor valve block, retain with screws and torque to 6 in.lbs.
NOTE: Do not lubricate the gasket or valve block surfaces.
5. Insert new, lubricated "U" cups in each of the air caps. The lips of the "U" cups should face towards the diaphragm chambers. Install the air cap seal.
6. Pre-assemble each of the two diaphragms by first inserting the diaphragm nut through the new diaphragms, Apply Loctite #242 to the threads, attach the backup washer, secure with the a 9/16" wrench and spanner wrench. Using a torque wrench, tighten the diaphragm nut and washer to 80-inch pounds.
NOTE: Be careful not to round off the diaphragm nut. Backup "O"rings are included in the Service Kit for models with PTFE diaphragms.

For the 637274-X and 637273-XXX Service Kits:

7. Install new, lubricated "O"rings onto the four complete check assemblies that are included with the Service Kit. Also put new "O"rings on each end of the two manifold tubes.

PUMP REASSEMBLY:

8. First hand tighten the connecting rod to one of the diaphragm assemblies.
9. Place the air cap on end. Insert the air valve assembly and bushing in place. (be sure the U-cups are installed). Align logo plates and push the air caps together.
NOTE: Be sure the bushing, and air valve assembly remain in place.
10. Lubricate the connecting rod and insert it into the air cap.
NOTE: Models with PTFE diaphragms have backup "O"rings that are placed in the groove of each air cap.

REASSEMBLY (CONT'D)

11. Attach the second diaphragm assembly to the connecting rod, hand tighten the (pre-assembled) diaphragm nut and washer until it bottoms out on the connecting rod.
NOTE: Models with Teflon diaphragms have backup "O"rings that are placed in the groove of each air cap. Do not over-tighten the nut.
12. Replace the "O"rings at the air inlet and exhaust ports of the air inlet fluid cap.
13. Properly align the fluid cap and attach it to the pump body. When in place, the air inlet should be at the upper right, with the exhaust at the lower left.
14. Insert a bolt into the bore just below the air inlet and one just above the exhaust port. Applying a small amount of anti-seize compound or lubricant to the threads will help prevent the nut from binding. Properly align the second fluid cap and push it into position.
15. Secure the fluid caps by installing nuts onto each bolts, but do not tighten fully at this time.
16. Insert the manifold tubes through the pump body, being careful that the "O"rings do not fall off during this step.
17. Press two of the check assemblies into the lower inlet ports of the fluid caps. The checks are keyed and can be assembled only one way.
NOTE: If the old checks are to be used, clean all parts in an appropriate solvent.
18. Place manifolds over each check, pushing firmly to secure the check and the manifold tube.
19. Press the remaining checks into the upper, outlet ports of the fluid caps. Make sure the smaller seat opening is inserted first.
20. Place manifolds over each check, pushing firmly to secure the check and the manifold tube.
21. Insert two bolts through each manifold. Secure by attaching a nut to each bolt. Applying a small amount of anti-seize compound or lubricant to the threads will help prevent the nut from binding.
22. Tightening sequence for the long bolts:
IMPORTANT ASSEMBLY NOTE: The fastener nuts have ribs which lock into the material, for best results place a socket wrench on the nuts so they are held stationary and tighten only the bolts they are used with.
 - ☞ Torque all six bolts to 40-inch pounds.
 - ☞ Cross tighten the bolts in an alternating star shaped pattern.
 - ☞ Repeat torque sequence twice.
23. Finish reassembly by pressing both cover plates into place.

TROUBLE SHOOTING

Air Motor stalls

- Check for blown Diaphragm
- Check for damaged "O"rings on the Spool.
- Check for damaged "O"rings on the Trip Rod.
- Check valve block gasket for leakage.

Air leaks from Exhaust

- Check for damaged "O"rings on the Valve Block and Minor Valve Block, Spool or Trip Rod.
- Check gasket between valve blocks for leakage.
- U-cups on Connecting Rod Bushing are damaged or installed backwards.

Fluid leaks from Exhaust

- Check for diaphragm damage.
- Check for diaphragm screws not adequately torqued.

Low flow, or pump continues to cycle after shut-off.

- Check for trapped air if the pump is oriented where the inlet check is above the outlet check. Temporarily increase the flow or re-prime the pump.
- Check for damaged seats or foreign matter clogging the check assembly.

Air leaks from pump (other than exhaust)

- Check for bolts not evenly or adequately torqued.
- Check for "O"ring missing/damage between the fluid cap and the air cap on the air inlet side.

External fluid leaks from pump.

- Check for bolts not properly torqued.
- Check for damaged "O"rings on the Manifold Tube.
- Check for damaged "O"rings on the Valve Check.
- Check for damaged diaphragm seal.

Pump operates but dispenses little or no fluid

- Check for obstruction in fluid line.
- Check for foreign matter clogging check assemblies.
Note: Install a fluid screen on the material inlet hose if the problem continues.
- Suction line too small.
- Check for air leakage at the air/fluid inlet pipe plugs. Use PTFE tape or pipe sealant upon assembly.

DIMENSIONAL DATA

Dimensions shown are for reference only, they are shown in inches and millimeters (mm).

END VIEWS

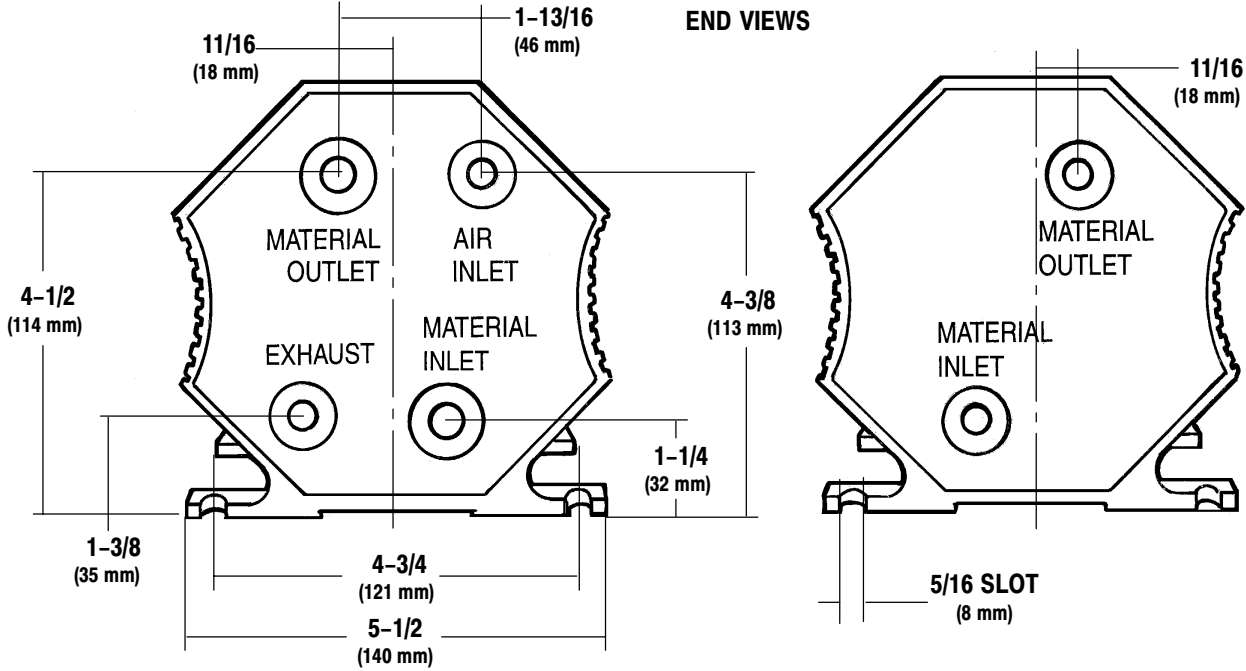

SIDE VIEW

