

# LANTRONIX

- **FOX3-2G Series**

- **FOX3-3G Series**

- **FOX3-4G Series**

- 

- **HARDWARE MANUAL**

- 



## Table of contents

<b>1. Introduction</b>	<b>6</b>
1.1. General	6
1.2. FOX3-2G/3G/4G/4G Series hardware differences	8
1.3. Package	8
1.4. Circuit concept	9
1.5. Related documents	10
<b>2. Disclaimer</b>	<b>12</b>
<b>3. Security</b>	<b>13</b>
3.1. General information	13
3.2. Exposure to RF energy	13
3.3. Driving	13
3.4. Electronic devices	13
3.5. Vehicle electronic equipment	13
3.6. Medical electronic equipment	13
3.7. Aircraft	14
3.8. Children	14
3.9. Blasting areas	14
3.10. Potentially explosive atmospheres	14
3.11. Safety for Li-Ion batteries	14
3.11.1. Safety precautions while charging the battery	15
3.11.2. Safety precautions while discharging Li-Ion battery	15
3.11.3. Safety precautions when replacing the battery	15
3.12. Non-ionizing radiation	15
<b>4. Safety standards</b>	<b>16</b>
<b>5. Technical data</b>	<b>17</b>
5.1. Product features	17
5.1.1. Power consumption for FOX3-2G/3G/4G	19
5.1.2. Operating temperatures	20
5.1.3. GSM/GPRS engine features	20
5.1.4. GNSS engine features	21
5.2. NMEA data message	22
<b>6. FOX3-2G/3G/4G application interface</b>	<b>23</b>
6.1. Power supply	23
6.1.1. Power supply pins (1 and 2) on the 8-pin connector	23
6.1.2. Automatic shutdown	23
6.1.3. Power saving	23
6.2. Determining the External Equipment Type	24
<b>7. Hardware Interfaces</b>	<b>25</b>
7.1. Main Port (8pin connector)	26
7.1.1. Main Port Pinout	26
7.1.2. Installation cable (KA70-FOX3-2G/3G/4G-KFZ-INST-1,5M-2x4)	27
7.1.3. Special pin description (Pins 4, 5, 6)	27
7.1.3.1. How to use I/O pins (4, 5, 6) as analog inputs	27

7.1.3.2. How to use I/O pins (4, 5, 6) as digital Inputs .....	28
7.1.3.3. How to use I/O pins (4, 5, 6) as digital outputs .....	29
7.1.3.4. How to use IGN pin (pin 3) .....	30
7.1.3.5. Serial Port 0 - Serial communication signals (RxA and TxA).....	31
<b>7.2. Accessory Port (6pin connector).....</b>	<b>31</b>
7.2.1. Accessory Port Pinout .....	31
7.2.2. 1-Wire interface description .....	33
7.2.2.1. Serial Port 1 - Serial communication signals (RxA_1 and TxA_1).....	34
<b>7.3. Inserting a SIM card into the SIM holder .....</b>	<b>34</b>
7.3.1. How to enter the PIN of the inserted SIM card.....	35
<b>7.4. LED indicators .....</b>	<b>36</b>
<b>7.5. 10pin mini-USB port.....</b>	<b>36</b>
7.5.1. Setting up a USB connection for FOX3-2G/3G/4G .....	37
7.5.1.1. Installing the CDC driver files for FOX3-2G/3G/4G.....	37
7.5.2. IOBOX-MINI/CAN/WLAN accessory devices for FOX3-2G/3G/4G.....	39
7.5.2.1. Connecting IOBOX-MINI/CAN/WLAN to FOX3-2G/3G/4G.....	39
7.5.2.2. IOBOX-MINI pinout.....	39
7.5.2.3. IOBOX-CAN/WLAN pinout .....	40
<b>7.6. Mounting .....</b>	<b>41</b>
7.6.1. External Antenna Ports .....	42
<b>7.7. Audio Interface .....</b>	<b>43</b>
<b>8. Housing.....</b>	<b>44</b>
<b>9. Appendix .....</b>	<b>45</b>
9.1. Schematics .....	45
9.1.1. Installation guidance .....	45
9.2. What should be considered when using FOX3-2G/3G/4G device .....	45
9.3. GPRS Coding scheme .....	46

## Version history:

*This table provides a summary of the document revisions.*

Version	Author	Changes	Modified
2.2.5	F. Beqiri	<ul style="list-style-type: none"> <li>- Added ISED RF Exposure information in both English and French – see chapter 10</li> <li>- Changed company logo to Lantronix.</li> </ul>	08/14/2019
2.2.4	F. Beqiri	<ul style="list-style-type: none"> <li>- The wakeup condition on “CAN” is only supported with command \$PFAL,Sys.Device.Doze.</li> </ul>	02/13/2018
2.2.3	F. Beqiri	<ul style="list-style-type: none"> <li>- Added IOBOX-WLAN - It is an IOBOX-CAN with additional WLAN connectivity. The pinout on the 16pin connector is the same as on IOBOX-CAN.</li> </ul>	08/22/2017
2.2.2	F. Beqiri	<ul style="list-style-type: none"> <li>- Added FOX3-4G-NA</li> <li>- Added a note when using digital outputs of the IOBOX-MINI and IOBOX-CAN – see tables in chapter 7.5.2.2 and 7.5.2.3</li> </ul>	26/06/2017
2.2.1	F. Beqiri	<ul style="list-style-type: none"> <li>- Added all models of FOX3 series – See chapter 1.1</li> <li>- Added table in chapter 1.2 - FOX3 series hardware differences.</li> <li>- Added power consumption for FOX3-3G. Updated power consumption for FOX3 - See chapter 5.1.1</li> <li>- Added operation frequencies for FOX3-3G – See chapter 5.1.3</li> <li>- Changed USB driver from FTDI to CDC.</li> <li>- Added new audio cable “CA81b” with with an integrated transformer that provides a full galvanic isolation - See chapter 7.7, Audio Interface</li> </ul>	09/02/2016
2.1.1	F. Beqiri	<ul style="list-style-type: none"> <li>- Internal information</li> </ul>	Cancelled
2.1.0	F. Beqiri	<ul style="list-style-type: none"> <li>- Added FOX3-3G. There are four models of FOX3-3G available: FOX3-3G, FOX3-3G-LITE, FOX3-3G-AU and FOX3-3G-BLE.</li> </ul>	10/01/2016
1.0.9	F. Beqiri	<ul style="list-style-type: none"> <li>- Updated power consumption - See chapter 5.1.1</li> <li>- Updated chapter 7.5.2 - Connecting the IOBOX-CAN</li> <li>- Added chapter 7.5.2.3 - IOBOX-CAN pinout</li> <li>- Added the audio cable with integrated transformer and galvanic isolation (CA81b) - see chapter 7.7</li> </ul>	20/07/2015
1.0.8	F. Beqiri	<ul style="list-style-type: none"> <li>- Unnamed: PAID-FEATURE in PREMIUM-FEATURE</li> </ul>	19/02/2015
1.0.7	F. Beqiri	<ul style="list-style-type: none"> <li>- Added point 6 in chapter 7.5.1.1 - Activation of the setting/option "Load-VCP" after installing the FTDI driver.</li> </ul>	10/27/2014
1.0.6	F. Beqiri	<ul style="list-style-type: none"> <li>- Added chapter 3.11.3, "Safety precautions when replacing the battery"</li> </ul>	10/24/2014
1.0.5	F. Beqiri	<ul style="list-style-type: none"> <li>- Added power consumption @ 24 VDC - see Table 3.1</li> </ul>	01/07/2014
1.0.4	F. Beqiri	<ul style="list-style-type: none"> <li>- Added: KA70 (3-Wires installation cable (V+, GND, IGN) - optional accessory)</li> </ul>	16/05/2014
1.0.3	F. Beqiri	<ul style="list-style-type: none"> <li>- Added: Power consumption @ 12 VDC - see chapter 5.1.1</li> <li>- Added: Installing USB drivers - see chapter 7.5.1.1</li> </ul>	14/05/2014
1.0.2	F. Beqiri	<ul style="list-style-type: none"> <li>- Added figure 1 in chapter 1.1</li> </ul>	30/01/2014
1.0.1	F. Beqiri	<ul style="list-style-type: none"> <li>- Chapter 7.1.3 updated</li> </ul>	27/01/2014
1.0.0	F. Beqiri	<ul style="list-style-type: none"> <li>- Initial version.</li> </ul>	15/12/2013

## Cautions

The information furnished herein by Lantronix is believed to be accurate and reliable. However, no responsibility is assumed for its use. Please, read carefully the safety precautions.

If you have any technical questions regarding this document or the product described in it, please contact your vendor.

General information about Lantronix and its range of products are available at the following Internet address: <http://www.lantronix.com/>

## Trademarks

Some mentioned products are registered trademarks of their respective companies.

## Copyright

This document is copyrighted by Lantronix with all rights reserved. No part of this documentation may be reproduced in any form without the prior written permission of Lantronix.

## Lantronix

No liability (incl. patent liability) is assumed with respect to the use of the information contained herein.

## Note

Because our products are being continuously improved, specifications and information given in this document are subject to change by Lantronix without notice.

# 1. INTRODUCTION

This product manual is only addressed to qualified personnel who are well skilled in electrical/electrical installation and not to the private consumers/end users. The installation, implementing or setting into operation of the product can be performed only by qualified personnel.

The product status described in this document may have changed since first publication and therefore the information in this document about the product status may be outdated. The latest product information is available in the download area of our website.

The engineering of the FOX3-2G/3G/4G products is built on the same technology combining both versions of the FOX-IN/EN devices with additional hardware extensions and mobile communications technology into one product. The main characteristic of these products is the on-board auto-switch that it supports connection to both internal and external antennas by automatically switching to the external antennas when connected. These AVL products are the first design to feature a hardware implementation of this technology.

## 1.1. General

We are using state-of-the-art technology to develop unique and low-cost devices for managing assets and vehicle tracking more effectively than current systems on the market today. FOX3-2G/3G/4G are compact and all-in-one devices with powerful integration capability. There are three models of FOX3 series available: **FOX3** with 2G communication network, **FOX3-3G** with UMTS/HSPA communication networks and **FOX3-4G** with LTE. FOX3-3G supports fall back to GPRS and EDGE when UMTS or HSPA are not available and FOX3-4G supports fall back to HSPA and EDGE, GPRS when LTE is not available.

Devices	Device series						
FOX3-2G	FOX3-2G	FOX3-2G-LITE					
FOX3-3G	FOX3-3G	FOX3-3G-LITE	FOX3-3G-AUDIO	FOX3-3G-BLE	FOX3-3G-BLE-BID	FOX3-3G-DR	
FOX3-4G	FOX3-4G-NA	FOX3-4G-EU					

Only **FOX3**, **FOX3-3G-AU** supports audio for speaker and microphone. The FOX3 series provide analog ports and integrates with 1-Wire interface. The 1-Wire interface supports connection with multiple sensors such as iButton, Temperature Logger, Temperature Sensor, Humidity sensor.



Figure 1: FOX3-2G/3G/4G networking and interfaces to peripheral devices.

Newly developed PREMIUM features show the way to the future of mobile data logging, storing, processing and sending. The needed hardware options can be decided shortly before installation depending on the application. FOX3-2G/3G/4G can act as a mobile client for various regular applications like AVL, fleet management, security and recovery of assets. The device offers new firmware features like: TCP DATA ENCRYPTION, several HISTORY MODES and ECO-DRIVE/BEHAVIOUR LOGGING beside standard items like status reports, messaging alerts, audio calls, spy calls and

Geo-fencing. The FOX3-2G/3G/4G units are delivered without SIM card and without battery. SIM cards must first be purchased and then registered into the GSM network before installing into the device. The battery can be ordered as an option (refer to the Ordering Guide for more information). The setup and configuration of the device is provided through Serial Ports, over SMS and TCP using special commands like "PFAL" and the Workbench Software configuration tool. These "PFAL" commands are special to AVL devices and can be used for all kinds of communications including Serial, SMS, CSD, TCP and SMTP. Please read the document "AVL\_PFAL\_Configuration\_Command\_Set.pdf" for more details about the PFAL-Commands.

Geofence features for territory management, route verification, prohibited locations, parking area and more with exception reporting to a wide variety of events, such as arrivals, departures, deliveries, pick-ups, illegal entries, unauthorized movement, etc are also implemented in the firmware. FOX3-2G/3G/4G contains a data-logger (history feature) that enables archiving of unique vehicle locations in sequence up to aprox. 231 days with an archiving interval of 20 sec.. The physical interface to the devices application is made through integrated main and accessory ports as well as the 10pin mini-USB port. These ports are required for controlling the units, receiving GPS location data, transferring data, power supply, extending the number of I/Os as well as for the use of extra external devices which are not integrated in the In-Vehicle Computers.

FOX3-2G/3G/4G are devices that can be configured and integrated onto any asset platform, including:

- Trailers
- Trucks
- Delivery vans
- Rail cars
- Industrial vehicles and more

and can be used in a variety of applications, including:

- Real time online tracking
- Fleet management / monitoring
- Security / emergency services
- Real time satellite navigation
- Territory management
- Personalized drivers logbook
- Route verification
- Trip management / Distance calculations
- Theft protection
- Toll collection / pay as you drive
- Eco-Drive - (PREMIUM feature)
- Encrypted TCP communication based on AES 128 bit algorithm - (PREMIUM feature) and more.

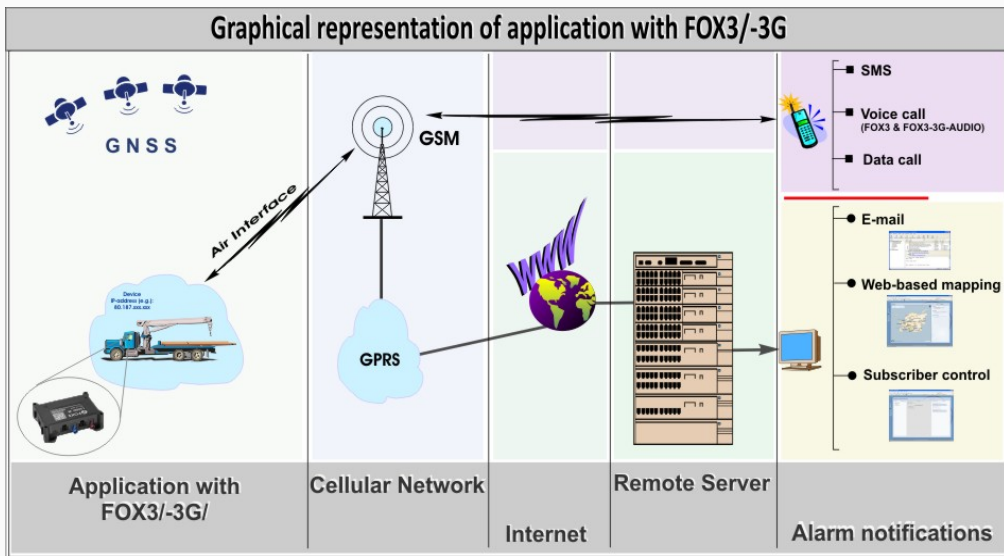

Figure 2: GSM/GPRS and GPS based vehicle tracking applications with FOX3-2G/3G/4G

### 1.2. FOX3-2G/3G/4G Series hardware differences

The following table shows the hardware differences between FOX3-2G/3G/4G/-4G Series.

Device models	GSM Core	GNSS Core	Serial 0	Serial 1	1-Wire	USB	Int/Ext Antenna	Audio	Bluetooth Low Energy
FOX3-2G (Std)	2G	GPS/GLONAS/ Galileo/BeiDou	✓	✓	✓	✓	✓	✓	
FOX3-2G-LITE	2G		✓			✓	✓		
FOX3-3G (Std)	3G*/2G		✓	✓	✓	✓	✓		
FOX3-3G-LITE	3G*/2G		✓			✓	✓		
FOX3-3G-BLE	3G*/2G		✓	✓	✓	✓	✓		✓
FOX3-3G-AU	3G*/2G		✓	✓	✓	✓	✓	✓	
FOX3-3G-DR	3G*/2G		✓	✓	✓	✓	✓		
FOX3-3G-BID	3G*/2G		✓	✓	✓	✓	✓		
FOX3-4G-NA	4G/3G/2G		✓	✓	✓	✓	✓		
FOX3-4G-EU	4G/3G/2G		✓	✓	✓	✓	✓		

4G: Cat 4 : 150 Mb/s DL, 50 Mb/s UL; 3G: 42 Mb/s downlink, 5.76 Mb/s uplink ; \*3G: 5.76 Mb/s uplink, 7.2 Mb/s downlink

Table 1: Hardware differences

### 1.3. Package

FOX3-2G/3G/4G devices are shipped in a cardboard box with following content:



Figure 3: FOX3-2G/3G/4G standard delivery

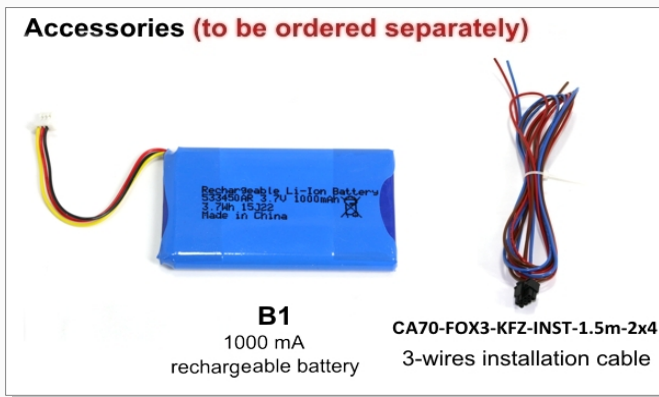

Figure 3.1: FOX3-2G/3G/4G basic accessories (to be ordered separately)

Please refer to the ordering guide for more details about the availability of other accessories.



## 1.4. Circuit concept

The architecture of the FOX3-2G/3G/4G devices consist of the following major components (as shown below):

Architecture Integrates	
- Quad-Band GSM/GPRS module or 3G module	
- GNSS receiver (GPS + GALILEO + GLONASS) - GLONASS needs to be activated	
- ARM7 processor controlling system functions	
- Inside SIM card holder (1.8/3V SIM cards)	
- Internal GSM/GNSS antennas	
- Main Port (Power, RS232 port, I/O ports)	
- Accessory Port (1-Wire, RS232 port, I <sup>2</sup> C interface)	
<ul style="list-style-type: none"> <li>▪ - <b>10pin mini-USB-connector (incl. SPI &amp; USB)</b></li> </ul>	
- Audio connector (Microphone & Speaker) - for FOX3 & FOX3-3G-AUDIO & FOX3-4G-NA	
<ul style="list-style-type: none"> <li>▪ - <b>GSM &amp; GNSS antenna ports (for external antennas)</b></li> </ul>	
Physical Interfaces	FOX3-2G/3G/4G accessories and hardware PREMIUM features
- 1 x Power supply lines	<ul style="list-style-type: none"> <li>▪ - <b>Backup battery 1000 mAh (B1 Option)</b></li> </ul>
- 3 x Multi-line I/O	<ul style="list-style-type: none"> <li>▪ - <b>IOBOX-MINI - I/O extension module</b></li> </ul>
- 1 x Ignition	- IOBOX-CAN - Second CAN-Bus interface
- 3 x LED indicators	- Car installation cable (more cables in the Ordering Guide)
- 2 x RS232 port (RX, TX, GND) V24	- CAN-Bus Interface
- 1 x 2.5mm audio port (not available on all models)	
- 1 x USB port	
- 1 x SPI interface (for IOBOX-MINI/ BT / CAN)	
- 1 x 1-Wire port	
- 1 x I <sup>2</sup> C port	
- 2 x External antenna port	
- 8 x Mounting Holes	

**Table 2:** FOX3-2G/3G/4G architecture

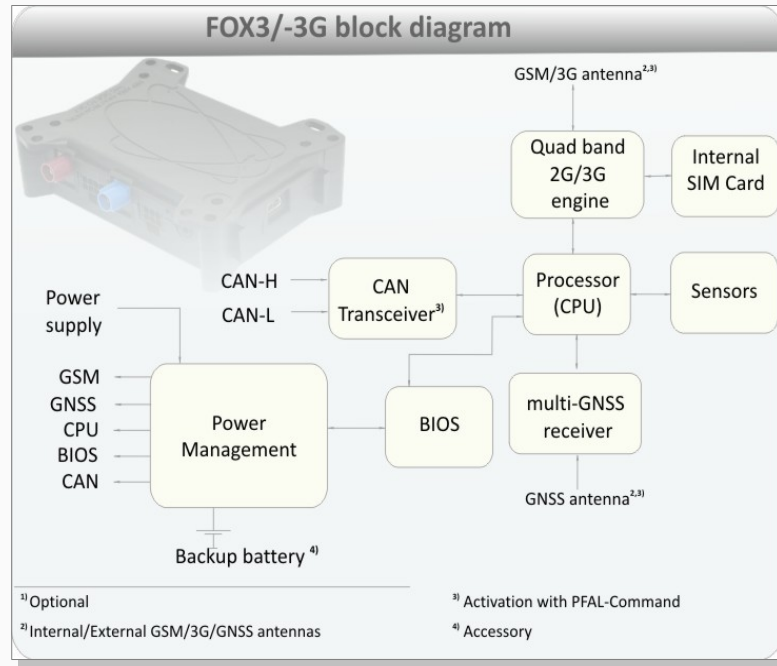

Figure 4: FOX3-2G/3G/4G block diagram

### 1.5. Related documents

In addition to this document, the following files comprise the full set of FOX3-2G/3G/4G product manuals:

NR	PDF file name	Description
[1]	AVL_PFAL_Command_Set.pdf	Contains the description of the internal firmware and the supported Configuration Command Set for the AVL devices.
[2]	AppNotes_Transform_history_data.pdf	Contains information of how to decode history data that are being transmitted from an AVL device via TCP connection.
[3]	AppNote_Remote_update.pdf	Contains information of how to upgrade AVL devices to a new firmware revision remotely via TCP (server based application).
[4]	AppNotes_AVL_Installation_Guide.pdf	This document provides all the necessary information how to install your product properly and safely in a vehicle.
[5]	AppNotes_ECO-DRIVE-GPS.pdf	This document contains information of how to use the features of the GPS-ECO-DRIVE supported as PREMIUM-FEATURE in the firmware version avl_2.11.0 and above.
[6]	AppNotes_AES_TCP.pdf	This document contains information of how to use the features of the AES_TCP (ADVANCED ENCRYPTION STANDARD) supported as PREMIUM-FEATURE in the firmware version avl_2.10.0 and above.
[7]	AppNotes_HowToActivatePremiumFeatures.pdf	This document contains information of how to activate a PREMIUM-FEATURE on an AVL device.
[8]	AVL_AppNote_RFID_Howto.pdf	This document contains information of how to connect and use an RFID-Reader to/with AVL devices.
[9]	AppNotesForCANBusApplication.pdf	This document contains information of how to connect AVL devices to the vehicle and how to configure and use the CAN-Bus features.
[10]	AppNote_CAN_FMS_CAN_OBDII_Howto.pdf	This document contains information of how to connect AVL devices to the vehicle and how to configure and use the CAN-Bus/FMS/OBDII features.
[11]	AppNote_WebUpdate_Howto.pdf	This document contains information of how to upgrade an AVL device firmware remotely over the air.
[12]	AppNote_Connecting_Barcode_Scanner.pdf	This document contains information of how to connect a bar code scanner to an AVL device and how to transmit the scanned data.
[13]	AVL_Software_Update.pdf	Contains information how to upgrade an AVL device to a new firmware version locally via serial port.
[14]	AppNotesRemoteUpdateWithWorkbench.pdf	Contains information how to upgrade AVL devices to a new firmware version remotely via TCP.
[15]	AppNote_1-Wire_Guide.pdf	Contains information how to use the 1-Wire interface on the FOX3-2G/3G/4G/-4G

NR	PDF file name	Description
		Series.
[16]	AppNote_IOBOX-CAN_D8_Interface_HowTo.pdf	Provides information on how to configure your FOX3 series devices in combination with the accessory box IOBOX-CAN/WLAN, connect the IOBOX-CAN/WLAN to D8 connector of the digital tachograph, read real time data from this interface and transfer them to your platform server.
[17]	AppNote_IOBOX_WLAN_HowTo.pdf	Provides information on how to configure your FOX3-3G/4G series devices in combination with the accessory box IOBOX-WLAN, connect the IOBOX-WLAN to your AP (access point) and send data over WLAN to your platform server.

These PDF files are viewable and printable from Adobe Reader. If you do not have the Adobe Reader installed, you can download it from <http://www.adobe.com>.

## 2. DISCLAIMER

This section explains our disclaimer concerning any application the customer may develop with AVL devices.

- (1) Due to the large variety of supported applications with AVL devices, We are not able to test all such types of applications.
- (2) The customer is solely responsible for proper use of the products and for a long-term test of the developed applications.
- (3) All applications are highly influenced by environmental conditions, correct handling, installation and device configuration/programming. We don't assume any responsibility for correct work of customer application and any results like damaging or losses on non-working.
- (4) We are not responsible for and disclaims all warranties of any kind with respect to third-party products and is also not responsible for any damages caused by use of the third-party products in any combination with devices. We cannot assure that third-party products will operate technically trouble free in use with products.
- (5) We recommend to perform a reasonable test of your application before deploying into the field. The test should be also performed on any modification of configuration/programming, firmware update or any other changes made on the connected devices or peripherals also before deploying the change into the field. The environmental conditions and the duration of these tests should reflect the conditions of the real use case/installation.

## 3. SECURITY

IMPORTANT FOR THE EFFICIENT AND SAFE OPERATION OF YOUR GSM-MODEM, READ THIS INFORMATION BEFORE USE!

Your cellular engines FOX3-2G/3G/4G are one of the most exciting and innovative electronic products ever developed. With them, you can stay in contact with your office, your home, emergency services and others, wherever service is provided.

This chapter contains important information for the safe and reliable use of the FOX3-2G/3G/4G devices. Please read this chapter carefully before starting to use the cellular engines FOX3-2G/3G/4G.

### 3.1. General information

Your FOX3-2G/3G/4G devices utilize the GSM/GNSS standard for cellular technology. GSM is a newer radio frequency („RF“) technology than the current FM technology that has been used for radio communications for decades. The GSM standard has been established for use in the European community and elsewhere. Your FOX3-2G/3G/4G are actually a low power radio transmitter and receiver. They send out and receives radio frequency energy. When you use your modem, the cellular system handling your calls, controls both the radio frequency and the power level of your cellular modem.

SIM cards are needed for the use of the acquired devices, which are not included in the scope of delivery of the device. The SIM cards can be acquired e.g. by specific providers. Additional costs can result from the use of the SIM cards which are to be borne by the purchaser (client) of the devices. The seller does not cover the extra costs for the use of the devices. The seller gives no recommendation for the use of specific SIM cards and is not liable for the fact that the devices are usable with all available SIM cards. The seller is also not liable for any other costs that are needed for the application of the customer in connection with this device.

### 3.2. Exposure to RF energy

There has been some public concern about possible health effects of using GSM modems. Although research on health effects from RF energy has focused for many years on the current RF technology, scientists have begun research regarding newer radio technologies, such as GSM. After existing research had been reviewed, and after compliance to all applicable safety standards had been tested, it has been concluded that the product is fit for use.

If you are concerned about exposure to RF energy, there are things you can do to minimize exposure. Obviously, limiting the duration of your calls will reduce your exposure to RF energy. In addition, you can reduce RF exposure by operating your cellular modem efficiently by following the guidelines below.

### 3.3. Driving

Check the laws and regulations on the use of cellular devices in the area where you drive. Always obey them. Also, when using your FOX3-2G/3G/4G while driving, please pay full attention to driving, pull off the road and park before making or answering a call if driving conditions so require. When applications are prepared for mobile use, they should fulfil road-safety instructions of the current law!

### 3.4. Electronic devices

Most electronic equipment, for example in hospitals and motor vehicles is shielded from RF energy. However, RF energy may affect some malfunctioning or improperly shielded electronic equipment.

### 3.5. Vehicle electronic equipment

Check your vehicle manufacturer's representative to determine if any on board electronic equipment is adequately shielded from RF energy.

### 3.6. Medical electronic equipment

Consult the manufacturer of any personal medical devices (such as pacemakers, hearing aids, etc.) to determine if they are adequately shielded from external RF energy.

Turn your FOX3-2G/3G/4G devices OFF in health care facilities when any regulations posted in the area instruct you to do so. Hospitals or health care facilities may be using RF monitoring equipment.

### 3.7. Aircraft

Turn your FOX3-2G/3G/4G OFF before boarding any aircraft. Use them on the ground only with crew permission. Do not use them in the air.

To prevent possible interference with aircraft systems, Federal Aviation Administration (FAA) regulations require you to have permission from a crew-member to use your modems while the plane is on the ground. To prevent interference with cellular systems, local RF regulations prohibit using your modems whilst airborne.

### 3.8. Children

Do not allow children to play with your FOX3-2G/3G/4G devices. It is not a toy. Children could hurt themselves or others (by poking themselves or others in the eye with the antenna, for example). Children could damage the modems or make calls that increase your modem bills.

### 3.9. Blasting areas

To avoid interfering with blasting operations, turn your device OFF when in a “*blasting area*” or in areas posted: „*turn off two-way radio*“. Construction crew often uses remote control RF devices to set off explosives.

### 3.10. Potentially explosive atmospheres

Turn your FOX3-2G/3G/4G devices **OFF** when in any area with a potentially explosive atmosphere. It is rare, but your modems or their accessories could generate sparks. Sparks in such areas could cause an explosion or fire resulting in bodily injury or even death. Areas with a potentially explosive atmosphere are often, but not always, clearly marked. They include fueling areas such as petrol stations; below decks on boats; fuel or chemical transfer or storage facilities; and areas where the air contains chemicals or particles, such as grain, dust or metal powders. Do not transport or store flammable gas, liquid or explosives, in the compartment of your vehicle, which contains your modem or accessories.

Before using your modems in a vehicle powered by liquefied petroleum gas (such as propane or butane) ensure that the vehicle complies with the relevant fire and safety regulations of the country in which the vehicle is to be used.

### 3.11. Safety for Li-Ion batteries

The FOX3-2G/3G/4G devices are shipped without battery inside. If a backup battery is needed, please refer to the Ordering Guide and follow the safety rules listed below.

The safety rules below are applied for the Li-Ion internal battery. Lithium-Ion (abbreviation: Li-Ion) batteries require particularly careful handling. This applies to charging and discharging techniques, and also to storage and other aspects of general handling. Mistreating the battery may cause the battery to get hot, crack, or inflame and cause serious injury. In order to avoid any damage and extend the life expectancy of battery, please follow the safety rules listed below before using FOX3-2G/3G/4G devices with battery option:

- Do not place the battery on, in or near fires, apparatus that provide heat, or other high-temperature locations. Do not place the battery in direct sunshine, or use or store the battery inside cars in hot weather. Doing so may cause the battery to generate heat, crack, or inflame. Using the battery in this manner may also result in a loss of performance.
- Do not attach the battery to a power supply plug or directly to a car’s cigarette lighter.
- Do not pierce the battery with nails, strike the battery with a hammer, step on the battery, or otherwise subject it to strong impacts or shocks.
- Do not solder onto the battery contacts.
- Do not allow the battery to get wet.
- Do not disassemble or modify the battery.
- Immediately discontinue use of the battery if, while using, charging, or storing the battery, the battery emits an unusual smell, feels hot, or appears abnormal in any other way.
- Do not place the batteries in microwave ovens, high-pressure containers, or on induction cookware.
- In case the battery drips and the fluid gets into one’s eye, do not rub the eye. Rinse well with water and immediately look for medical care. If left untreated the battery fluid could cause damage to the eye.

### 3.11.1. Safety precautions while charging the battery

Be sure to follow the rules listed below while charging the battery. Failure to do so may cause the battery to become hot, rupture, or ignite and cause serious injury.

- When charging the battery insure that the battery charging conditions specified are met. The temperature range over which the battery can be charged is 0°C to 40°C. Charging is interrupted, if the ambient temperature is outside of this range.

### 3.11.2. Safety precautions while discharging Li-Ion battery

The temperature range over which the battery can be discharged is -20°C to 60°C. Use of the battery outside of this temperature range may damage the performance of the battery or may reduce its life expectancy.

### 3.11.3. Safety precautions when replacing the battery

The following notes describe information that you must consider when replacing the battery. The lithium battery must be handled correctly to avoid possible danger.

Replace the battery only with the same battery that comes with the device. Use of another battery invalidates all warranty claims for the device.



**Caution:** risk of explosion if battery is replaced by an incorrect type.

Dispose of the used battery as required by local ordinances or regulations.

## 3.12. Non-ionizing radiation

The FOX3-2G/3G/4G devices come with internal and external GSM/3G/4G/GNSS antennas. Therefore, care should be taken to install the devices/antennas in such a position that no part of the human body will normally rest within 20 cm of any part of the antennas for more than a few minutes whilst the equipment is in use. It is also recommended to use the devices not close to medical devices as for example hearing aids and pacemakers.

## 4. SAFETY STANDARDS

Your GSM/GPRS/3G/4G/GNSS devices complies with all applicable RF safety standards.

FOX3-2G/3G/4G meet the safety standards for RF receivers and the standards and recommendations for the protection of public exposure to RF electromagnetic energy established by government bodies and professional organizations, such as directives of the European Community, Directorate General V in matters of radio frequency electromagnetic energy.



## 5. TECHNICAL DATA

### 5.1. Product features

- **Supply voltage range:**
  - Operating power supply voltage range of +10.8 V to +32.0 V, suitable for direct connection to an automotive +12V or +24V DC power source (vehicle battery).
- **Power saving:**
  - 10 different energy-saving modes - programmable with PFAL commands. See chapter 6.1.3 for more details.
- **Operating temperature range:**
  - - 40°C to + 85°C (see chapter 5.1.2 for more details).
- **Physical characteristics:**
  - Size: 83.0 ± 0.5 mm x 105 ± 0.5 mm x 28.0 ± 0.5 mm
  - Weight (without battery): ca. 130 gr.
- **Physical Interfaces:**
  - Main Port (8pin row connector) comprising:
    - ✓ 3 x I/Os multi functional pins (each pin has dual functions as analog or digital - software configurable. Each digital pin can individually be set as an input or output)
    - ✓ 1 x Ignition pin (software controlled feature)
    - ✓ 1 x Power supply (software controlled feature)
    - ✓ 1 x Serial port (Rx, Tx), Baud rate is controlled by firmware 4800...115200 bps (default=115200 bps), 8 data bits, no parity, 1 stop bit, no flow control.
  - Accessory Port (6pin row connector) comprising:
    - ✓ 1-Wire line for connecting 1-Wire slave devices, such as iButton, temperature & humidity sensors etc.
    - ✓ I<sup>2</sup>C interface
    - ✓ 1 x Serial port (Rx, Tx), Baud rate is controlled by firmware 4800...115200 bps (default=115200 bps), 8 data bits, no parity, 1 stop bit, no flow control.
  - 10pin mini-USB connector comprising:
    - ✓ USB port
    - ✓ SPI interface.
  - Inside SIM card holder (supports 1.8/3 V SIM cards)
  - Built-in 3D G-sensor for power management, motion and shock alarm
  - 3 x LED indicators (red, green, blue) free-programmable
  - External ports for connecting a GSM / GNSS antenna
  - Audio interface with 2.5 mm female jack for connecting a headset (FOX3 & FOX3-3G-AUDIO & FOX3-4G).

- **Accessories (to be ordered separately - see ordering guide):**
- **Backup Li-Polymer battery**
- **Car Installation Cable**
- **Accessory Installation Cable**
- **GSM/GNSS quad-band external antenna (FAL-ANT-11) for FOX3**
- **GSM/GNSS penta-band external antenna (FAL-ANT-12) for FOX3-3G**
- **GSM/GNSS penta-band external antenna (FAL-ANT-14) for FOX3-4G**
- **IOBOX-MINI (external I/O extension device - up to 13 inputs/outputs)**
- **IOBOX-CAN (external device with 2<sup>nd</sup> CANBus interface and 8 I/O)**
- **Casing:**
  - Fully shielded.
- **Air humidity:**
  - 5 % up to 95 % (non-condensing).
- **Directive:**
  - RoHS compliant (RoHS Directive 2002/95/EC)
- **Firmware:**
  - Embedded TCP/IP stack, including TCP, IP, SMTP and UDP protocols
  - Accessible via PFAL commands
  - Upgradable locally via serial port and remotely over the air (OTA).
- **Internal memory:**
  - 8 Mbyte FLASH for configuration, data-logging and firmware storage
  - 2 MByte RAM.
- **Supported protocols:**
  - NMEA Msg.: GLL, GGA, RMC, VTG, GSV, GSA
  - Own Msg.: **IOP, GSM, AREA, 3DP, BIN** - see related documents [1] and Table 5.
- **GSM/3G/4G/GNSS antenna:**
  - Internal antennas and external antenna ports with built-in auto switch
  - Connect / Disconnect event generation.

### 5.1.1. Power consumption for FOX3-2G/3G/4G

All measurements have been performed with  $T_{amb} = 23^{\circ}\text{C}$ ,  $V_{IN+} = 12\text{ V DC}$ ; **FOX3**: DCS 1800 MHz, Power Level 10, Cell Power -75dBm; **FOX3-3G**: UMTS 2100 Mhz;

Modes	Average power consumption @ +12 V				Comments
	FOX3-2G	FOX3-3G	FOX3-4G	Unit	
Max.	> 1	> 1	>1	A	In a transmit burst the current consumption can rise to typical peaks of 1A
CPU on / GPS on / GSM off	38	41	61	mA	GPS-fix valid.
CPU on / GPS off / GSM on	40	49	58	mA	GSM idle (registered) and GPRS detached.
CPU on / GPS on / GSM on	49	48	74	mA	Power mode = disable, GPS fix valid, GPRS and TCP connected.
	26	30	-	mA	Power mode = auto, GPS fix valid, GPRS and TCP connected.
	13	25	-	mA	Power mode = doze, GPS fix valid, GPRS and TCP connected.
Transmit Data	120	132	230	mA	Sending data over TCP

**Table 3:** Current consumption at 12 VDC

All measurements have been performed with  $T_{amb} = 23^{\circ}\text{C}$ ,  $V_{IN+} = 24\text{ V DC}$ ; **FOX3**: DCS 1800 MHz, Power Level 10, Cell Power -75dBm; **FOX3-3G**: UMTS 2100 Mhz;

Modes	Average power consumption @ +24 V				Comments
	FOX3-2G	FOX3-3G	FOX3-4G	Unit	
Power mode = disabled					
Transmit Data	60	68	94	mA	Sending data over TCP
CPU on / GSM on /GPS on	-	-	38	mA	Microcontroller is ON, GPS fix valid, GPRS and TCP connected.
Power mode = Auto					
CPU on / GSM on /GPS on	33	18	-	mA	Microcontroller is ON, GPS fix valid, GPRS and TCP connected.
CPU on / GSM on /GPS off	25	12	-	mA	Microcontroller is ON, GPRS and TCP connected.
Power mode = Doze					
CPU on / GSM on /GPS on	15	18	-	mA	Microcontroller is ON, GPRS and TCP connected.
CPU on / GSM on /GPS off	7	16	-	mA	Microcontroller is ON, GPRS and TCP connected.

**Table 3.1:** Current consumption at 24 VDC

Sleep Modes	Average current consumption in sleep mode @ 12 V (external power)			Unit
	FOX3-2G	FOX3-3G	FOX3-4G	
IGN	< 1	< 1	< 1	mA
IGN+Ring	12	13	14	mA
IGN+Timer	1.5	2	3	mA
IGN+GPS	5	13	14	mA

**Table 3.2:** Power supply and current consumption for different sleep modes.

### 5.1.2. Operating temperatures

Parameter	Min.	Typ.	Max.	Unit
Storage temperature	-40	+25	85	°C
Storage temperature	-20	+25	+60	°C
Operating temperature	-40	+25	+85	°C
GSM*	-30	+25	+80	°C
Charging temperature (battery-operated **)	0	+25	+45	°C
Discharging temperature (battery-operated **)	-20	+25	+60	°C

\* The GSM/GPRS module is fully functional (-20 °C to + 55 °C meets the 3GPP specifications).

\*\* Optional. Storage and using conditions of the device with battery option are limited to the battery temperature range.

Table 4: Operating temperature for FOX3-2G/3G/4G

### 5.1.3. GSM/GPRS engine features

#### ▪ GSM/GPRS core:

Device	Supported frequencies				
	LTE		UMTS	GSM/GPRS	
	Category	Bands	Bands	Slot class	Band
FOX3	-	-	-	12	850/900/1800/1900
FOX3-3G	-	-	1/2/5/8	12	850/900/1800/1900
FOX3-4G-NA	4	2/4/5/7/17	1/2/4/8/5	12	850/900/1800/1900
FOX3-4G-EU	4	1/3/5/7/8/20	1/2/4/8/5	12	850/900/1800/1900

#### ▪ All devices are compliant to GSM Phase 2/2+.

- FOX3-4G-NA is designed for operation in North America

#### ▪ Output power:

- Class 4 (2 W) at EGSM900/850
- Class 1 (1 W) at GSM1800 and GSM 1900.

#### ▪ GPRS connectivity:

- GPRS multi-slot class 12
- GPRS mobile station class B.

#### ▪ DATA:

##### LTE:

- Downlink transfer: max. 150 Mbps
- Uplink transfer: max. 50 Mbps

##### HSPA:

- Downlink transfer: max. 7,2 Mbps
- Uplink transfer: max. 5,76 Mbps

##### GPRS:

- Downlink transfer: max. 85.6 kbps (see table 13)
- Uplink transfer: max. 42.8 kbps (see table 13)
- Coding scheme: CS-1, CS-2, CS-3 and CS-4.

##### CSD:

- CSD transmission rates: 2.4, 4.8, 9.6, 14.4 kbps, non-transparent, V.110.

- **SMS:**
  - Text mode.
- **Ring tones:**
  - Offers a choice of 19 different ringing tones/melodies, easily selectable with PFAL commands.

#### 5.1.4. GNSS engine features

- **GNSS engine:**
  - Multi channel GNSS (GPS/Galileo/GLONASS/BeiDou) receiver
  - GPS L1 C/A code
- **Accuracy:**
  - Position: 2.5 m CEP
  - SBAS: 2 m CEP.
- **Time to First Fix (TTFF):**
  - Hot starts: 1 sec.
  - Cold starts: 26 sec.
- **Sensitivity:**
  - Tracking: -161 dBm
  - Cold start: -148 dBm.
- **Operational limits:**
  - Velocity: 500 m/s (972 knots)
  - Altitude: 50,000 m
  - Max. update rate: 1 Hz.
- **A-GPS support:**
  - AGPS: Online / Offline / Autonomous.
- **Crystal oscillator (TCXO):**
  - Load sensitivity:  $\pm 10\%$  load change,  $0.2 \pm$  ppm.

## 5.2. NMEA data message

FOX3-2G/3G/4G deliver data in the NMEA-0183 format and own format. The table below lists the NMEA and own supported protocols and gives also a brief description for each of them. For further description about these protocols, refer to the related documents [1].

These protocols can be sent via SMS, TCP, data call, serial port, e-mail or stored inside the device using the corresponding PFAL-Commands. For example, the PFAL-Command "**PFAL,GSM.Send.TCP...**" allows sending the protocols via TCP to a remote server including the current device location, GPS state, UTC time, date, speed and course over ground. The received protocols by the server can then be used for graphical representation of the device location. Installing such a device in a vehicle, lets you know where your vehicle is, what is happening with your vehicle, has your vehicle been moved without authorization from a park area, updating vehicle movements in real time and more. The TCP server developed by called "**D2Sphere**" has a lot of such features allowing you to have a full control of your vehicle, fleet and your assets.

NMEA	Description
GPGGA	It contains GPS time, position and fix type data.
GPGLL	It contains GPS latitude, longitude, UTC time of position fix and status.
GPGSA	It contains satellites used in the GPS position solution and DOP values.
GPVTG	It contains the number of GPS satellites in view satellite ID numbers, elevation, azimuth and SNR values.
GPGSV	It contains the number of GPS satellites in view satellite ID numbers, elevation, azimuth and SNR values.
GPRMC	It contains GPS time, date, position, course and speed data.
GLGSA	It contains the GNSS DOP and Active Satellites (if GLONASS activated)
GLGSV	It contains the GNSS satellites in view (if GLONASS activated)
GPIOP	It contains the status of digital/analog inputs and output ports and battery voltage (if battery available).
GPGSM	It contains the GSM operator, reception, registration status, GSM field strength, area code and cell ID.
GPAREA	It contains the state (entered or left the area/geofence) of 32 areas and 100 geofences - such as territory management, route verification, prohibited locations, parking area and more.
GP3DP	It contains the state values of the motion sensor.
BIN	The user protocol contains GPS time, date, position, course and speed data in binary format (small sized - only 21 characters).

**Table 5:** NMEA Output Messages

## 6. FOX3-2G/3G/4G APPLICATION INTERFACE

### 6.1. Power supply

The power supply for the FOX3-2G/3G/4G devices has to be a single voltage source of  $V_{+IN} = +10.8\text{ V} \dots +32.0\text{ V}$  DC. The operating voltage ( $V_{+IN}$ ) has to be applied permanently to the FOX3-2G/3G/4G devices and able to provide sufficient current of up to **1.5 A** (pulse).

The operating voltage ( $V_{+IN}$  and GND) is protected against voltage spikes and reverse polarity, but **NOT** protected against continuous overvoltage.

**NOTE: Operating voltage range must never be exceeded; care must be taken in order to fulfill min/max voltage requirements.**

#### 6.1.1. Power supply pins (1 and 2) on the 8-pin connector

One +IN pin on the main 8-pin port is dedicated to connect the supply voltage, and the GND pin for grounding.

Both +IN and GND pins serve for charging the connected backup battery (option) and also for powering the FOX3-2G/3G/4G devices. FOX3-2G/3G/4G have an automatic power ON-function when external power is applied and no battery connected. The power supply for the FOX3-2G/3G/4G ranges from  $V_{+IN} = +10.8\text{ V} \dots +32.0\text{ VDC}$  allowing direct connection to vehicle power system.

Signal name	I/O	Parameter	Description
+IN	I	+10.8 V...+32.0 VDC. The operating voltage must never be exceeded.	Positive operating voltage. For security reason, it is recommended to protect the input voltage by and external 2A fuse between the device and d.c.-power source (see Fig 15).
GND	-	0 V	Ground (should be isolated from the vehicle grounds when the device is going to be installed in a vehicle)

#### 6.1.2. Automatic shutdown

Automatic shutdown takes effect if:

- under voltage is detected (internal battery level runs below the nominal voltage and the external power supply is disconnected).

#### 6.1.3. Power saving

SLEEP mode reduces the functionality of the modules of the FOX3-2G/3G/4G devices to a minimum and, thus, minimizes the current consumption to the lowest level. The FOX3-2G/3G/4G can be set into the sleep mode using the command `$PFAL,Sys.Device.Sleep[ChargeSleep,Doze]` with one or more parameters listed in the table below. Following SLEEP modes are supported by the FOX3-2G/3G/4G devices:

Modes	Description
Example	<code>\$PFAL,Sys.Device.Sleep=IGN+Ring+Timer=1:20:00</code> <code>\$PFAL,Sys.Device.ChargeSleep=IGN</code> <code>\$PFAL,Sys.Device.Doze=Ign+Wakeup=23:20:00</code>
IGN	Device wakes-up when a rising edge (Low to High signal) on the IGN pin is detected.
Ring	Device wakes up on incoming voice call or SMS.
<b>Wakeup=15:30:00</b>	Device wakes up at the set wake up time.
<b>Timer=1:20:00</b>	Device wakes up when timeout has expired.
<b>Motion=200</b>	Device wakes up when the set motion value is exceeded.
ExtPwrDetect	Device wakes up when external power connection is detected.
ExtPwrDrop	Device wakes up when external power disconnection is detected. For battery powered devices, the device wakes up when the battery voltage drops below the minimum.
GPS	Sets the GPS receiver into the Hibernate state
CAN*	Device wakes up when activities on the CAN bus interface are detected. <b>This wakeup condition is</b>

Modes	Description
	<b>supported only with \$PFAL, Sys.Device.Doze.</b>
LowBat=3.6	Device wakes up when the battery voltage drops below the specified value

**IMPORTANT:** The sleep and wake-up procedures are quite different depending on the selected sleep mode. Please note that the power saving with "Ring" works properly only when the PIN authentication has been done and the device is already registered in the GSM network. If you attempt to activate power saving while the device is not registered in the GSM network, the SIM card is not inserted or the PIN not correctly entered, the device responds error "**ring shutdown aborted due to bad GSM coverage**" and the power saving does not take place.

**NOTE:** Related to the battery-powered devices only:  
 When activating any sleep mode, make sure that the internal battery has enough power to safely wake up the device from that sleep mode. If the internal battery does not have enough power, the device can not complete the wake up process.

## 6.2. Determining the External Equipment Type

Before you connect the serial port pins of the FOX3-2G/3G/4G devices to an external equipment, you need to determine if the external hardware serial ports are configured as DTE (*Data Terminal Equipment*) or DCE (*Data Communications Equipment*).

FOX3-2G/3G/4G are designed for use as DCE devices. Based on the conventions for DCE-DTE connections, it communicates with the customer application (DTE) using the following signals:

FOX3-2G/3G/4G Terminal (DCE)	to	Application (DTE)
RxA	<-----	TXD
TxA	----->	RXD
GND	-	GND

**Table 6:** The signaling definitions between DTE and DCE.



## 7. HARDWARE INTERFACES

This chapter describes the hardware interfaces:

Interface specifications	
Main Port	The 8pin double-row connector, type: MOLEX-43045-08-MICRO FIT. It provides IN/OUT, power supply and first serial port (SER0) lines. The same pin functionality as FOX-IN/EN.
Accessory Port	The 6pin double-row connector, type: MOLEX-43045-06-MICRO FIT. It provides 1-Wire bus, I <sup>2</sup> C master interface, second serial port (SER1).
10pin-Mini-USB	10pin mini-USB port with SPI interface and USB - Master interface.
Optical LED Indicators	3 x LED indicators, free programmable using PFAL commands to show the device current state .
Mounting Holes	4 x mounting holes for attaching the device to a suitable location (use M4x20 self tapping or machine screws for mounting, <b>not included</b> ).
Audio interface	The audio connector has a diameter of 2.5 mm which allows to connect a SPK/MIC device to the FOX3-2G/3G/4G. <b>Hint:</b> Only FOX3 and FOX3-3G-AUDIO have this connector and support audio for speaker and microphone.
External Antenna Ports	FAKRA connectors for connecting GSM & GNSS antennas.
Battery tray	It is used to insert and connect the battery to the device.
SIM Holder	It is used to insert your SIM card into the device for using GSM/GPRS services.

**Table 7:** Interface specifications

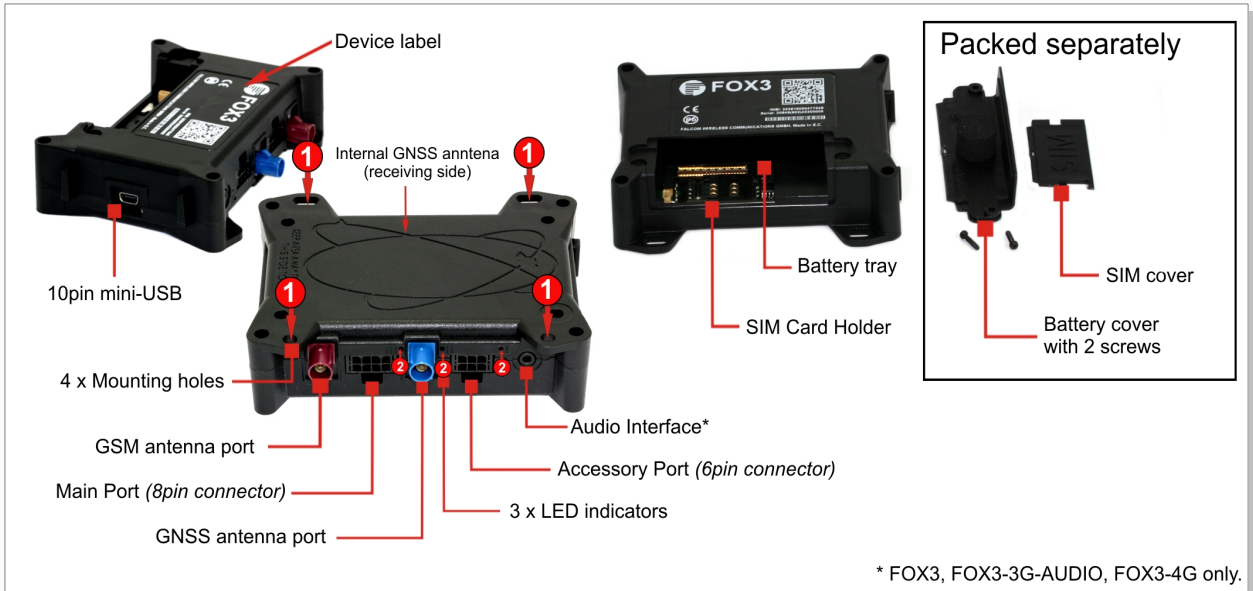

**Figure 5:** Interface specifications for FOX3-2G/3G/4G devices.

## 7.1. Main Port (8pin connector)

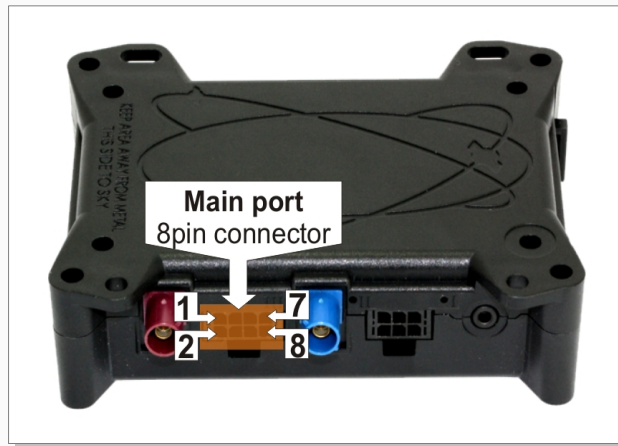

Figure 6: Pin assignments of 8-pin (2x4) connector (Type: MOLEX-43045-08-MICRO FIT)

### 7.1.1. Main Port Pinout

PIN	NAME	DIRECTION	DESCRIPTION	LEVEL
1	+IN	Input	Power supply input. The power supply must be able to meet the requirements of current consumption. Care must be taken so that the operating voltage, applied to the device, stay within the voltage range. Applying a voltage outside of the voltage range can damage the device. For security reason, it is recommended to integrate externally a 2A fuse link between power source and FOX3-2G/3G/4G.	$V_{+IN} = + 10.8 \dots + 32.0 \text{ V}$ $I_{max} \leq 1.5 \text{ A}$
2	GND	-	Ground.	0 V
3	IGN	Input	General purpose input. It can be either connected to the vehicle ignition and be used for journey START and STOP reports, or be connected to the operating voltage +IN and be used to wakeup the FOX3-2G/3G/4G devices from IGN-Sleep mode ( <i>awaking from this mode requires a HIGH signal</i> ). See also chapter 7.1.3.4.	<b>HIGH</b> $\geq +10.8 \dots +32.0 \text{ V DC}$ ; <b>LOW</b> = 0V
4	I/O1	Input/Output	Software configurable pins. Each pin has dual functions as analog or digital. Each digital pin can individually be set either as input or output.	<b>OUT:</b> 100 mA max. @ +0 .. +32.0V DC (open collector)
5	I/O2	Input/Output	Every time the device starts up, a level change occurs on the I/O2 and I/O3 pins. Only I/O1 doesn't change the level on device start up. Pins I/O2 and I/O3 support CAN communication if this interface is activated. The CAN-Bus interface can be activated using the corresponding PFAL command (see PFAL command set for more details). In this case the I/O2 = CAN_L and the I/O3 = CAN_H).	<b>IN:</b> 0 V..+32.0V DC ( <b>High &amp; Low</b> levels are free-programmable)
6	I/O3			<b>Analog :</b> Up to 32.0 V DC/10 bits resolution
7	RxA_0	Input	( <b>Serial Port 0</b> ) The serial port (receive data) for direct connection to the host PC (for configuration, evaluation, firmware). If this pin is not used leave it open.	V24, $\pm 12 \text{ V}$
8	TxA_0	Output	( <b>Serial Port 0</b> ) Serial port (transmit data) for direct connection to the host PC (for transmitting history data, output GPS protocols and more). If not used leave it open.	

Table 8: Description of the main port (8-pin connector)

### 7.1.2. Installation cable (KA70-FOX3-2G/3G/4G-KFZ-INST-1,5M-2x4)

This cable, which is NOT included in the standard delivery, is needed to install your FOX3-2G/3G/4G to the vehicle. If you need this cable, you can order it by contacting your vendor.

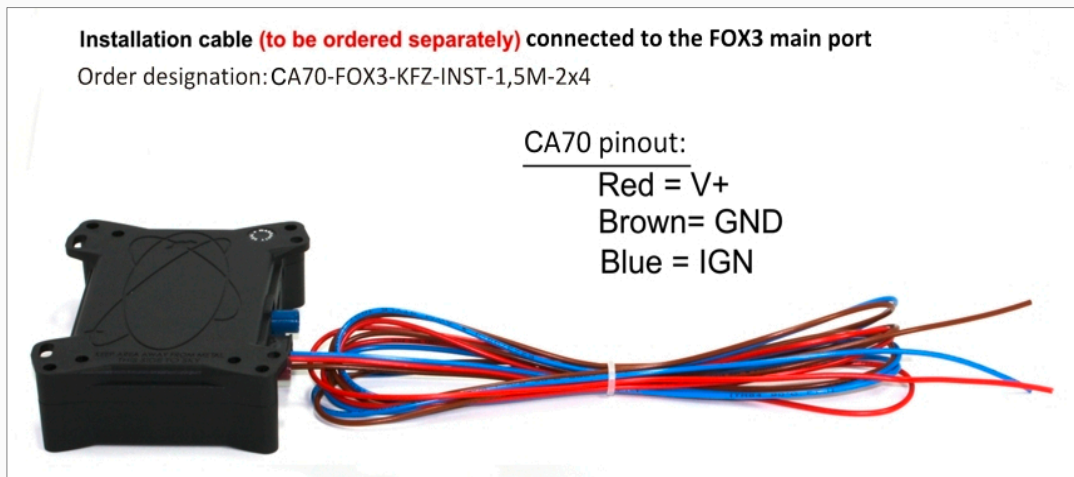

Figure 7: FOX3-2G/3G/4G installation cable (KA70-FOX3-2G/3G/4G-KFZ-INST-1,5M-2x4).

### 7.1.3. Special pin description (Pins 4, 5, 6)

The I/O2 and I/O3 (pin 5 and 6) can also operate as CAN-Bus interface if CAN is activated on the FOX3-2G/3G/4G devices. More details about the CAN interface can be found in the PDF-files:

- 1) [AVL\\_PFAL\\_Configuration\\_Command\\_Set.pdf](#),
- 2) [AppNotesForCANBusApplication\\_xxx.pdf](#) and
- 3) [AppNote\\_CAN\\_FMS\\_CAN\\_OBDII\\_Howto\\_vxxx.pdf](#).

These pins have dual functions. All are controlled by the internal firmware of FOX3-2G/3G/4G. Therefore, the user must define whether to use them as analog or digital pins. The configured digital pins can be inputs or outputs while the analog pins can only be inputs.

Their function is controlled by the command **PFAL,IO0[1,2].Config**. For example, if you want to use I/O1 as an analog pin, and the I/O2 and I/O3 as digital, then use the following commands respectively:

```
$PFAL,IO0.Config=AI,2,11 // 0 = I/O1; AI = analog; 2 and 11 = min. and max. voltages for Low and High events
$PFAL,IO1.Config=DI,5,10 // 1 = I/O2; DI = digital input; 5 and 10 = min. and max. voltages for Low and High events
$PFAL,IO2.Config=DI,5,10 // 2 = I/O3; DI = digital input; 5 and 10 = min. and max. voltages for Low and High events
```

If you want to use a digital pin, e.g. I/O2 or I/O3, as a digital output pin, then use the following PFAL command:

```
$PFAL,IO4.Set=high //4= I/O1; high = sets output to high
$PFAL,IO5.Set=high //5 = I/O2; high = sets output to high
$PFAL,IO6.Set=cyclic,2000,1000 //6 = I/O3; cyclic = sets output to high for 2 seconds and low for 1 seconds.
```

Some examples how to use them are given in the sections below.

When using an I/O as digital pin you must set it first to high (with PFAL command “**\$PFAL,IO4.Set=high**” or “**\$PFAL,IO5.Set=high**” or “**\$PFAL,IO6.Set=high**”), otherwise 0V will be measured (and the device could get damaged).

#### 7.1.3.1. How to use I/O pins (4, 5, 6) as analog inputs

These pins can operate either as digital or analog inputs, however they should be configured and calibrated with PFAL commands for such purposes.

Analog voltages of up to 32.0V with a 10 bits resolution can be processed and remotely evaluated by a server application. A pull-up resistor to a constant input voltage allows for resistive transducers to ground, e.g. fuel sensor or thermistors.

To use these IOs as analog inputs, send the following command to the device.

```
$PFAL,IO0[1,2].Config=A1,2,11
```

where 0, 1 and 2 are indices corresponding to IO1 (pin 4), IO2 (pin 5) and IO3 (pin 6), respectively. While the value 2 and 11 are min. and max. voltages that will be used to generate Low and High events, respectively. Detailed information can be found in the software manual "AVL\_PFAL\_Configuration\_Command\_Set.pdf".

**Connection example 1 (for I/O1 and I/O2):**

An analog input can be connected to a temperature sensor (a NTC resistor for instance). In the diagram below is used a fixed resistor from the input voltage to the I/O2, and a variable resistor (Negative Temperature Coefficient - whose resistance or capacitance decreases when temperature increases) to ground. It is possible to set a low temperature alarm and a high temperature alarm. Passage through these thresholds will trigger an alarm. We recommend to use SMS or TCP as alarm type with GPIOP protocol. The SMS can be received on a mobile phone, modem or any GSM device when changes are detected. The analog-to-digital converter (ADC) inside the unit has an input voltage range from 0 to 2.5 V. An application example is shown in figure below:

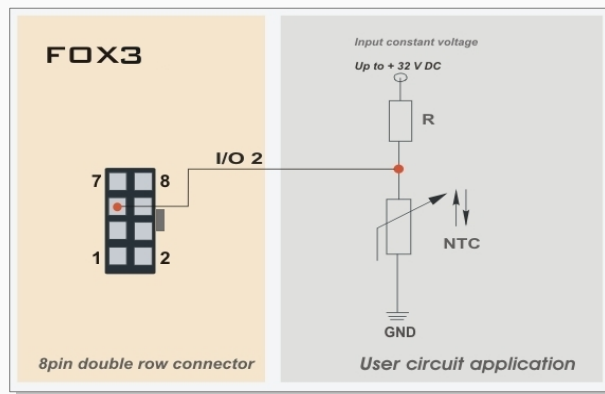

Figure 8: Connection example 1 when using it as analog input.

**Connection example 2 (for I/O1 and I/O2):**

An analog input can be connected to a tachometer generator. The maximum output voltage of the tachometer should be + 32.0 V (see illustrated example in figure below).

**Both circuit examples (the NTC diagram above and the Tachometer below) are only illustrations to show the aim of these I/Os when using them as analog inputs.**

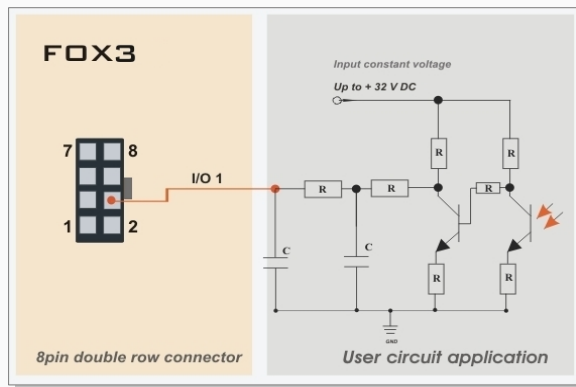

Figure 8.1: Connection example 2 when using it as analog input.

**7.1.3.2. How to use I/O pins (4, 5, 6) as digital Inputs**

These pins are high active when used as digital inputs, so you can set  $V_{IN(LOW)}$  and  $V_{IN(HIGH)}$  to any levels within the range from +0 to +32.0 VDC. The High and Low levels can be set with PFAL command (e.g.

**PFAL,IO0[1,2].Config=DI,5,10** - where 0, 1 and 2 are indices corresponding to IO1 (pin 4), IO2 (pin 5) and IO3 (pin 6) respectively. The values 5 and 10 are min. and max. voltages that will be used to generate Low and High events

respectively. Detailed information about PFAL commands can be found in software manual “AVL\_PFAL\_Configuration\_Command\_Set.pdf”.

The figure below illustrates how these inputs can be used in practice. When the internal software detects input changes from *High* to *Low* or vice versa, a *Falling* or *Rising* edge Event is respectively generated. Therefore, depending on the alarm type, the FOX3-2G/3G/4G can react to the input changes and release different alarms such as sending out SMS, email messages, TCP packets, opening a CSD connection or activating output ports. The alarm type is configuration-dependent.

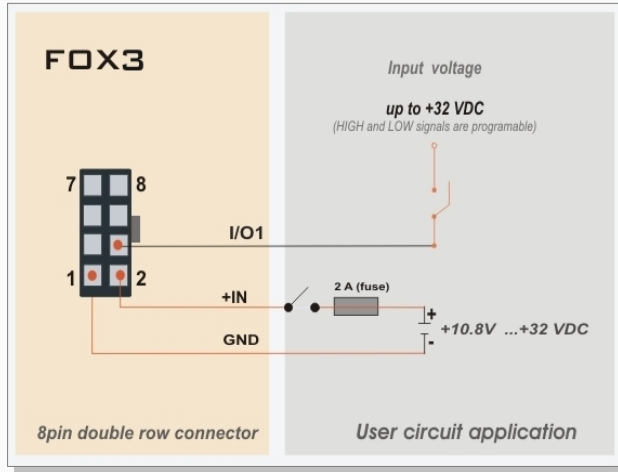

Figure 9: Connection example when using it as digital input.

A completed circuit example for all inputs is attached in section 9.1.1.

7.1.3.3. How to use I/O pins (4, 5, 6) as digital outputs

FOX3-2G/3G/4G devices support three IOs which can be used either as input or output. These outputs are open collectors. They can be connected directly via resistors (R) to LEDs, Relays etc., which need no more power than 100 mA @ up to + 32.0 V DC. The figures below show the schematic of possible output connections. To activate these outputs use the command `$PFAL,IO4[5,6].Set=high[low,hpulse,lpulse,cyclic]` for IO1, IO2 and IO3 respectively or you can configure one or more alarms that activate these outputs when specific events occur (e.g. `$PFAL,Cnf.Set,AL0=IO.e8=redge:IO4.Set=cyclic,1000,2000`).

In order to evaluate this alarm, send firstly this alarm configuration to the FOX3-2G/3G/4G devices and then trigger IGN-pin to High – as result the IO1 goes High for 1 sec and Low for 2 sec. To set IO1 to Low, just execute the command `PFAL,IO4.Set=Low`. For more details how to activate an output and how to configure an alarm, refer to the manual “AVL\_PFAL\_Configuration\_Command\_Set.pdf”. Both figures below show the schematic connections of how to use this output. **Please note that, the power should not be applied directly to an output pin without having e.g. a resistor between them.**

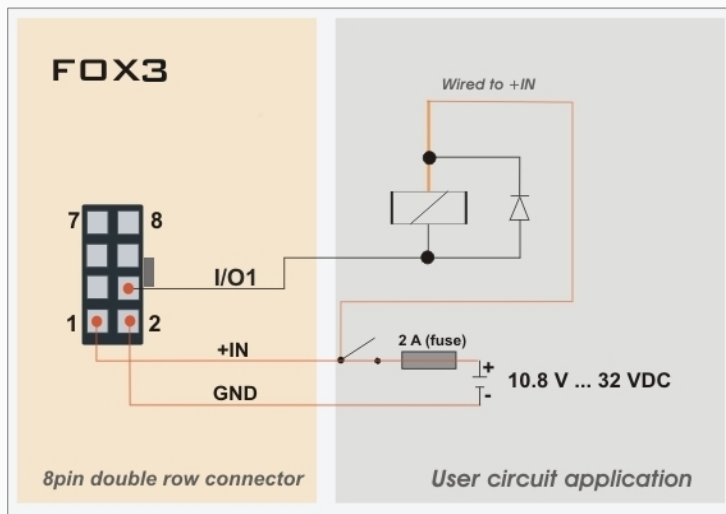

Figure 10: Connection example 1 when using it to control an Relay.

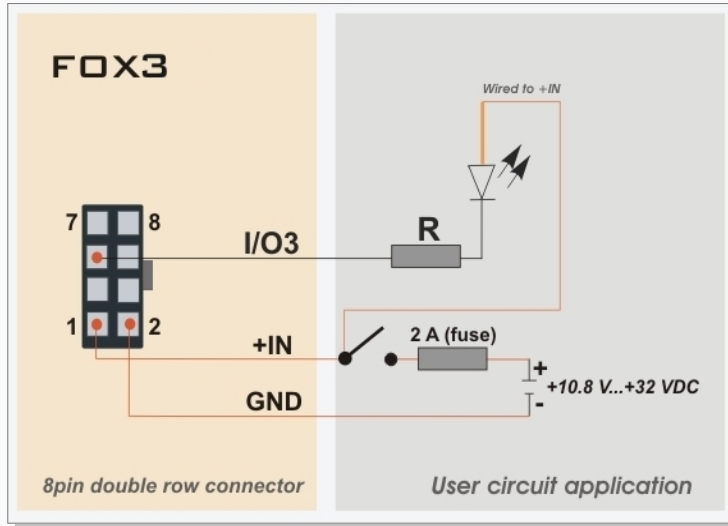

Figure 10.1: Connection example 2 when using it to control an LED.

7.1.3.4. How to use IGN pin (pin 3)

It is strongly recommended to connect this pin to the ignition key to support the IGN-power saving function when the vehicle is off.

The IGN-pin has two functions:

- ✓ It wakes up the system FOX3-2G/3G/4G from the IGN-sleep mode (when sleeping),
- ✓ and can be used to monitor the vehicle ignition state, to report/store the trip START and STOP by using the events **IO.e8=redge** and **IO.e8=fedge** respectively.

IGN-sleep mode is one of the eight supported energy-saving modes of the device operation in which all unnecessary components are shut down. On IGN wake-up signal, the device returns to full functionality.

Note that, FOX3-2G/3G/4G devices power on automatically when external power is applied, and IGN pin provides an additional "wake up" function for the IGN-sleep mode when it is requested.

In case of unauthorised vehicle access/start, you are automatically alarmed by SMS or TCP and the vehicle recovery can be started by knowing its exact location. In such a case, use the IGN generated event as a condition to start the vehicle tracking.

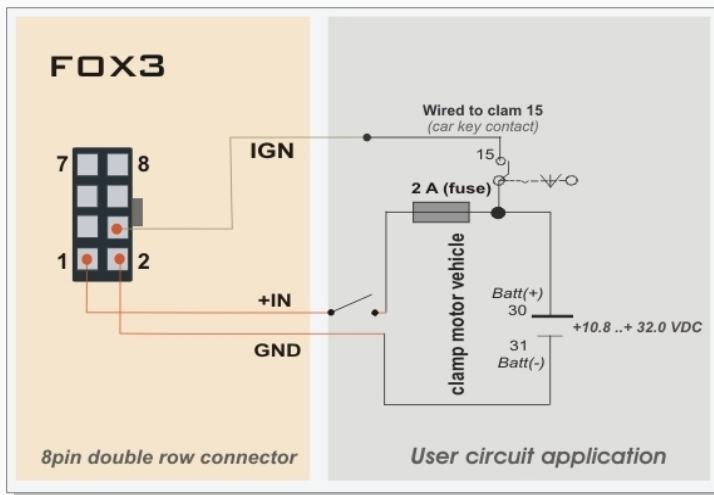

Figure 11: Monitoring vehicle starter by IGN line

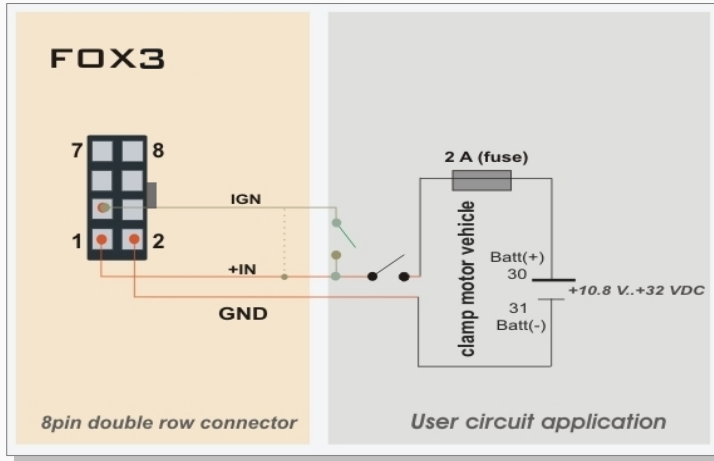

Figure 11.1: Use IGN line to wake FOX3-2G/3G/4G up from IGN-Sleep

7.1.3.5. Serial Port 0 - Serial communication signals (RxA and TxA)

FOX3-2G/3G/4G devices incorporates a full duplex serial channel which allows two devices to communicate directly with each other via the RS232 serial port. All supported variable baud rates are software-controlled. It is recommended to use the FOX3-2G/3G/4G Evalboard in order to communicate with the FOX3-2G/3G/4G devices, since you will find there all you need to evaluate with it. The signals on these pins are obtained to RS232 compatible signal levels.

**RxA\_0** Main channel used to receive software commands to the board from any software (e.g. HyperTerminal). Moreover, the firmware update can also be done through this serial port.

**TxA\_0** Main channel used to output navigation, measurement, response and system data to any software (e.g. HyperTerminal, Workbench).

7.2. Accessory Port (6pin connector)

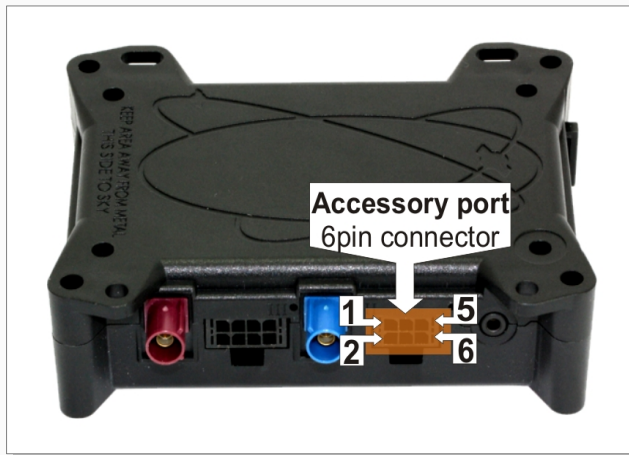

Figure 12: Pin assignments of 6-pin (2x3) connector (Type: MOLEX-43045-06-MICRO FIT)

7.2.1. Accessory Port Pinout

PIN	NAME	DIRECTION	DESCRIPTION	LEVEL
1	1-Wire	Input /Output	1-Wire master interface for Driver ID, temperature and humidity sensors.	VOUT = + 2.8 .. +5.0 V
2	GND	-	Ground Reference.	0 V
3	RxA_1	Input	(Serial Port 1) Serial port (receive data) for direct connection to the host PC (configuration, evaluation, firmware). If not used leave it open.	V24, ±12 V

4	TxA_1	Output	(Serial Port 1) Serial port (transmit data) for direct connection to the host PC (transmitting history data, output GPS protocols and others). If not used leave it open.	V24, ±12 V
5	SCL	Output	I2C bus interface - Serial Clock line – the signal used to synchronize communication between the master and the slave.	
6	SDA	Input /Output	I2C bus interface - Serial Data line – the signal used to transfer data between the transmitter and the receiver.	

**Table 9:** Description of the 6-pin (2x3) connector



### 7.2.2. 1-Wire interface description

A 1-Wire bus uses only one wire for signaling and power. One or several 1-Wire devices can be connected to the bus at the same time. Only one master should be connected to the bus.

Driver identification, temperature and humidity sensors are quite often used on vehicle applications. Thanks to the integration of 1-wire interface into the FOX3-2G/3G/4G devices, the system integrators for telematics, fleet management and intelligent transportation system can be cost-benefit and time efficiently for their work due to the use of extra external devices which are not integrated in the in-vehicle computers. Using of the 1-Wire interface, you are able to know which drivers are in which vehicles and at the same time monitor the temperature and humidity of their refrigerated trucks. In this way, shippers can record by their server the transportation and the delivery state of their temperature-sensitive loads.

#### How does it work?

A 1-Wire network consists of a master controller which is connected to one or many slave devices. The 1-Wire interface on FOX3-2G/3G/4G is a master controller. All of the actual monitoring devices (lightning detector, moisture meter, motion detector, barometer, etc.) are slave devices. FOX3-2G/3G/4G communicate with temperature and iButton devices via 1-Wire protocol developed by Dallas Semiconductor, sending and receiving signals over a single data line plus ground reference. The 1-Wire protocol synchronizes the monitoring devices to the FOX3-2G/3G/4G. FOX3-2G/3G/4G initiate and requests all activities on the 1-Wire network. One key feature of the Dallas system is that every 1-Wire slave device has a guaranteed unique address saved on-chip ROM (Read Only Memory). This enables the master to recognize individually each of your slave devices, and means you can have multiple devices of the same type on the same network without conflict.

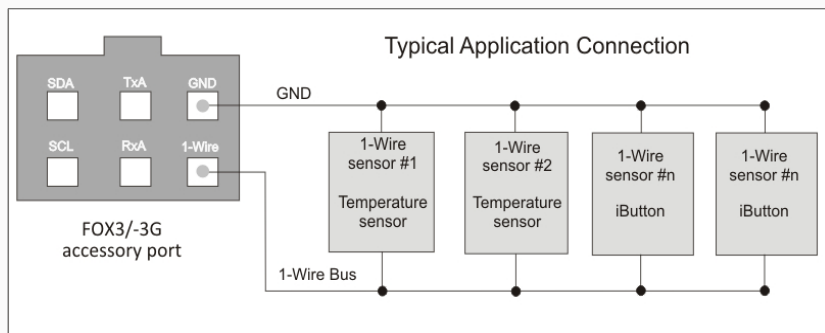

Figure 13: Typical application connection

Setting up a 1-Wire network with the FOX3-2G/3G/4G devices is quite easy. 1-Wire is a simple system of devices such as temperature, iButton devices etc. that are connected through the 1-Wire data line plus ground reference to the FOX3-2G/3G/4G devices. Remember that you can use and connect to the FOX3-2G/3G/4G 1-Wire line only sensors that require power supply anywhere between 2.9V and 5.0V. FOX3-2G/3G/4G devices receive on demand the unique address of the temperature and iButton IDs and other information they deliver. This information can then be sent via alarms to the remote TCP server.

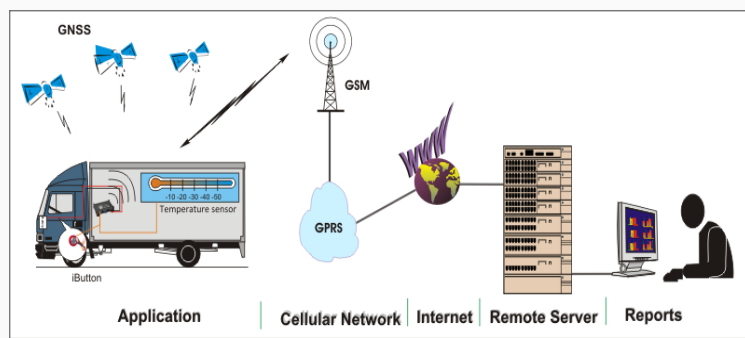

Figure 13.1: Typical application using 1-Wire single line.

More details about the 1-Wire interface, refer to the application note "[AppNote\\_1-Wire\\_Guide.pdf](#)".

### 7.2.2.1. Serial Port 1 - Serial communication signals (RxA\_1 and TxA\_1)

The FOX3-2G/3G/4G devices incorporate a full duplex serial channel in the accessory port which allows two devices to communicate directly via RS232 serial ports. All supported baud rate are controlled by PFAL commands. In order to communicate with the FOX3-2G/3G/4G devices, it is recommended to use the FOX3-2G/3G/4G PromotionKit since you will find there all what you need for your evaluation. The signals on these pins are obtained to RS232 compatible signal levels.

<b>RxA_1</b>	Receive channel and can be used for executing commands and firmware update.
<b>TxA_1</b>	Output channel for responses and system data to any software (e.g. HyperTerminal, Workbench).

## 7.3. Inserting a SIM card into the SIM holder

FOX3-2G/3G/4G devices have a GSM modem that requires a SIM card to access to the mobile network services. The SIM card is obtained from your mobile provider and must be activated for GSM data services before using it. Together with the SIM card, you receive a 4-digit PIN number. Entering of the PIN allows your device to access the mobile network.

To insert the SIM card into the FOX3-2G/3G/4G' SIM holder, follow the steps below:

- 1) Remove the power supply and any other connections from the device. Turn the FOX3-2G/3G/4G devices on their back side as shown in the figure 14 below.
- 2) Indicate the SIM card holder on the left of the battery try (1). To open it, push the metal slider in direction marked "OPEN".
- 3) Flip the card holder up (2).
- 4) Insert the SIM card (3) into the card holder in direction as shown in the figure below.
- 5) Flip the card-holder back (without force) (4), then hold it pressed and move the metal slider in direction marked "LOCK" until it stops.
- 6) Insert the SIM card cover in the direction as shown in picture below (5) and slide it until it stops.
- 7) If you have already ordered a backup battery to connect it to the FOX3-2G/3G/4G (e.g. B1 - 1000 mAh battery, see figure 14.1 below), just plug in the 3pin connector of the battery cable to the battery connector on the left side in the battery tray (FOX3-2G/3G/4G PCB).
- 8) Finally, place the battery cover and then screw it with both screws and a T6-TORX screwdriver (6). When tightening the screws, apply a tightening torque equal or less to these values: TORX 6 screwdriver with a fixed torque of 0.3 - 0.4 Nm

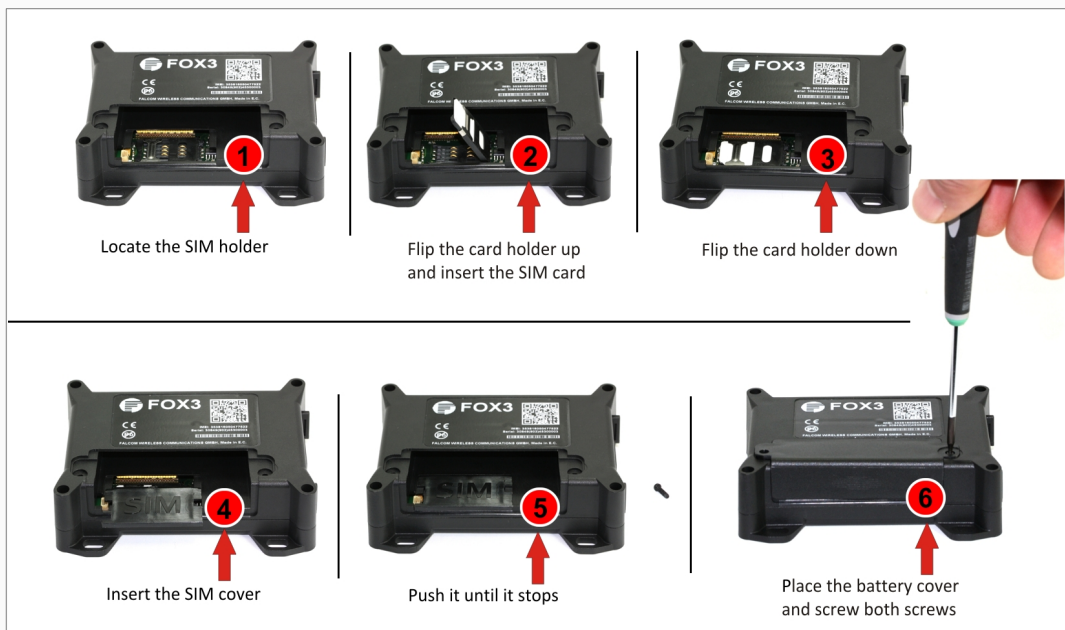

Figure 14: Steps for inserting the SIM card into FOX3-2G/3G/4G devices