

raft

WiPort



WiPort™ Integration Guide

Part Number 900-333
Revision G June 2006

Copyright and Trademark

© 2005, 2006, Lantronix. All rights reserved. No part of the contents of this book may be transmitted or reproduced in any form or by any means without the written permission of Lantronix. Printed in the United States of America.

WiPort, with its patent-pending technology, is a trademark of Lantronix.

Ethernet is a trademark of XEROX Corporation. UNIX is a registered trademark of The Open Group. Windows 95, Windows 98, Windows 2000, Windows NT, and Windows XP are trademarks of Microsoft Corp. Netscape is a trademark of Netscape Communications Corporation.

Contacts

Lantronix Corporate Headquarters

15353 Barranca Parkway
Irvine, CA 92618, USA
Phone: 949-453-3990
Fax: 949-453-3995

Technical Support

Phone: 800-422-7044 or 949-453-7198
Fax: 949-450-7226
Online: www.lantronix.com/support
Email support@lantronix.com

Sales Offices

For a current list of our domestic and international sales offices, go to the Lantronix web site at www.lantronix.com/about/contact/

Disclaimer



This equipment has been tested and found to comply with the limits for a Class B digital device, pursuant to Part 15 of the FCC Rules. These limits are designed to provide reasonable protection against harmful interference in a residential installation. This equipment generates, uses and can radiate radio frequency energy and, if not installed and used in accordance with the instructions, may cause harmful interference to radio communications. However, there is no guarantee that interference will not occur in a particular installation. If this equipment does cause harmful interference to radio or television reception, which can be determined by turning the equipment off and on, the user is encouraged to try to correct the interference by one of the following measures:

- ◆ Reorient or relocate the receiving antenna.
- ◆ Increase the separation between the equipment and receiver.
- ◆ Connect the equipment into an outlet on a circuit different from that to which the receiver is connected.
- ◆ Consult the dealer or an experienced radio/TV technician for help.

This device complies with Part 15 of the FCC Rules. Operation is subject to the following two conditions: (1) This device may not cause harmful interference, and (2) this device must accept any interference received, including interference that may cause undesired operation.

This device is intended only for OEM Integrators. The OEM integrator should be aware of the following important issues.

Labeling of the End Product

The end product to integrate this module has to be clearly identified on the label that this end product contains an FCC approved RF module. The format of such statement could be "Contains Transmitter with FCC ID: **R68WIPORTG**" or similar.

Integration Note

a) This module is authorized under limited module approval specified to mobile host equipment. So, the antenna must be installed such that 20cm is maintained between the antenna and users.

b) The transmitter module may not be co-located with any other transmitter or antenna.

As long as the 2 conditions above are met, further transmitter testing will not be required. However, the OEM integrator is still responsible for testing their end-product for any additional compliance requirements required with this module installed (for example, digital device emission, PC peripheral requirements, etc.)

Note: *In the event that these conditions can not be met (for example certain laptop configurations, general purpose PCMCIA or similar cards, or co-location with another transmitter), then the FCC authorization is no longer considered valid and the FCC ID can not be used on the final product (including the transmitter) and obtaining a separate FCC authorization.*

Note: *Changes or modifications to this device not explicitly approved by Lantronix will void the user's authority to operate this device.*

Contents

1: Introduction	6
About the Integration Guide _____	6
Additional Documentation _____	6
2: Description and Specifications	7
WiPort Overview _____	7
WiPort Block Diagram _____	8
PCB Interface _____	9
Mating Connector _____	10
Serial Input/Output _____	10
Sample Layouts for RS-485 Connectivity _____	12
WLAN Input/Output _____	13
Ethernet Input/Output _____	13
Power, Ground, and Reset _____	14
Absolute Maximum Ratings _____	14
Recommended Operating Conditions _____	14
Ethernet PHY Receiver Input Characteristics (RX+, RX-) _____	15
100Base-TX Transceiver Characteristics (TX+, TX-) _____	15
Wireless Specifications _____	15
Technical Specifications _____	17
Dimensions _____	18
Recommended PCB Layout _____	19
Product Information Label _____	20
3: Development Kit	21
Contents of the Kit _____	21
Evaluation Board Description _____	21
Serial Interfaces _____	21
Power Supply _____	22
General Control PLD _____	22
Configuration Switch Bank _____	22
Evaluation Board Layout _____	23
Evaluation Board Schematics _____	24
Compliance Information _____	28
Warranty _____	29

List of Figures

Figure 2-1. WiPort Block Diagram.....	8
Figure 2-2. Combined RS-232/485 Transceiver	12
Figure 2-3. Separate RS-232/485 Transceivers	12
Figure 2-4. Separate RS-485 Transceivers for 2-Wire and 4-Wire Setups.....	13
Figure 2-5. Side Views	18
Figure 2-6. Top View.....	18
Figure 2-7. Bottom View.....	19
Figure 2-8. PCB Layout.....	19
Figure 2-9. Product Label.....	20
Figure 3-1. WiPort Evaluation Board Layout.....	23
Figure 3-2. Evaluation Board Schematics.....	24

List of Tables

Table 2-1. PCB Interface Signals.....	9
Table 2-2. Mating Connectors.....	10
Table 2-3. Channel 1 Connections.....	11
Table 2-4. Channel 2 Connections.....	11
Table 2-5. Channel 2 RS-422/485 4-Wire Connections.....	11
Table 2-6. Channel 2 RS-485 2-Wire Connections.....	11
Table 2-7. WLAN Signals.....	13
Table 2-8. Ethernet Signals.....	13
Table 2-9. Power, Ground, and Reset Pins	14
Table 2-10. Absolute Maximum Ratings	14
Table 2-11. Operating Conditions, Serial Ports, & Configurable Pins.....	14
Table 2-12. Ethernet Input Characteristics.....	15
Table 2-13. 100Base-TX Transceiver Attributes	15
Table 2-14. Wireless Specifications	15
Table 2-15. Technical Specifications	17
Table 3-1. RS-232 Signals	22
Table 3-2. Channel 2 RS-485 4-Wire Connector	22
Table 3-3. Channel 2 RS-485 2-Wire Connector	22
Table 3-4. Jumper Configurations.....	22
Table 3-5. Configurable Pin Configurations	23

1: Introduction

About the Integration Guide

This guide provides the information needed to integrate the WiPort device server within another product. The intended audiences are the engineers responsible for integrating the WiPort into their product.

Additional Documentation

The following guides are available on the product CD and the Lantronix Web site (www.lantronix.com)

**WiPort™ Development Kit
Quick Start Guide**

Briefly explains the basics to get the WiPort up and running.

WiPort™ User Guide

Provides information needed to configure, use, and update the WiPort firmware.

1.2: Description and Specifications

The WiPort wireless embedded device server is a complete network-enabling solution based on the IEEE 802.11b/g wireless standard, with WPA and WEP capabilities. WiPort allows Original Equipment Manufacturers (OEMs) to add wireless connectivity to their products by incorporating it onto a circuit board with minimal engineering.

The WiPort functions independently of a PC, providing an integrated solution that combines a processor, memory, 802.11b/g transceiver and dual high-speed serial ports into a single compact module. It includes a wireless connection, an operating system, an embedded Web server, and a full TCP/IP protocol stack. In addition, the WiPort sends email alerts and supports numerous other network communication protocols, including ARP, UDP, TCP, ICMP, Telnet, AutoIP, DHCP, HTTP and SNMP.

WiPort Overview

The WiPort contains Lantronix's own DSTni controller with 256 Kbytes of internal zero wait state SRAM, 16 Kbytes of boot ROM, and integrated 10/100 PHY.

The WiPort also contains the following:

- ◆ Two 3.3-volt v24 serial interfaces (5V tolerant)
- ◆ Up to 921600 Baud
- ◆ 16 or 32Mbit flash memory (with optional additional 8Mbit SRAM)
- ◆ 88 MHz clock
- ◆ 802.11b interface
- ◆ 11 configurable pins
- ◆ 10/100 Ethernet interface

The WiPort requires +3.3-volt power and is designed to operate within a temperature range of -30°C to +70°C.

WiPort Block Diagram

The following drawing is a block diagram of the WiPort showing the relationships of the components.

Figure 2-1. WiPort Block Diagram

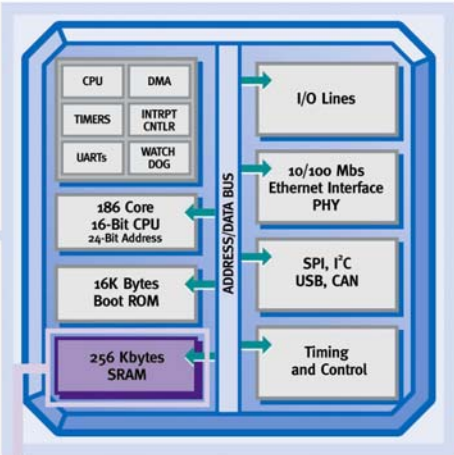
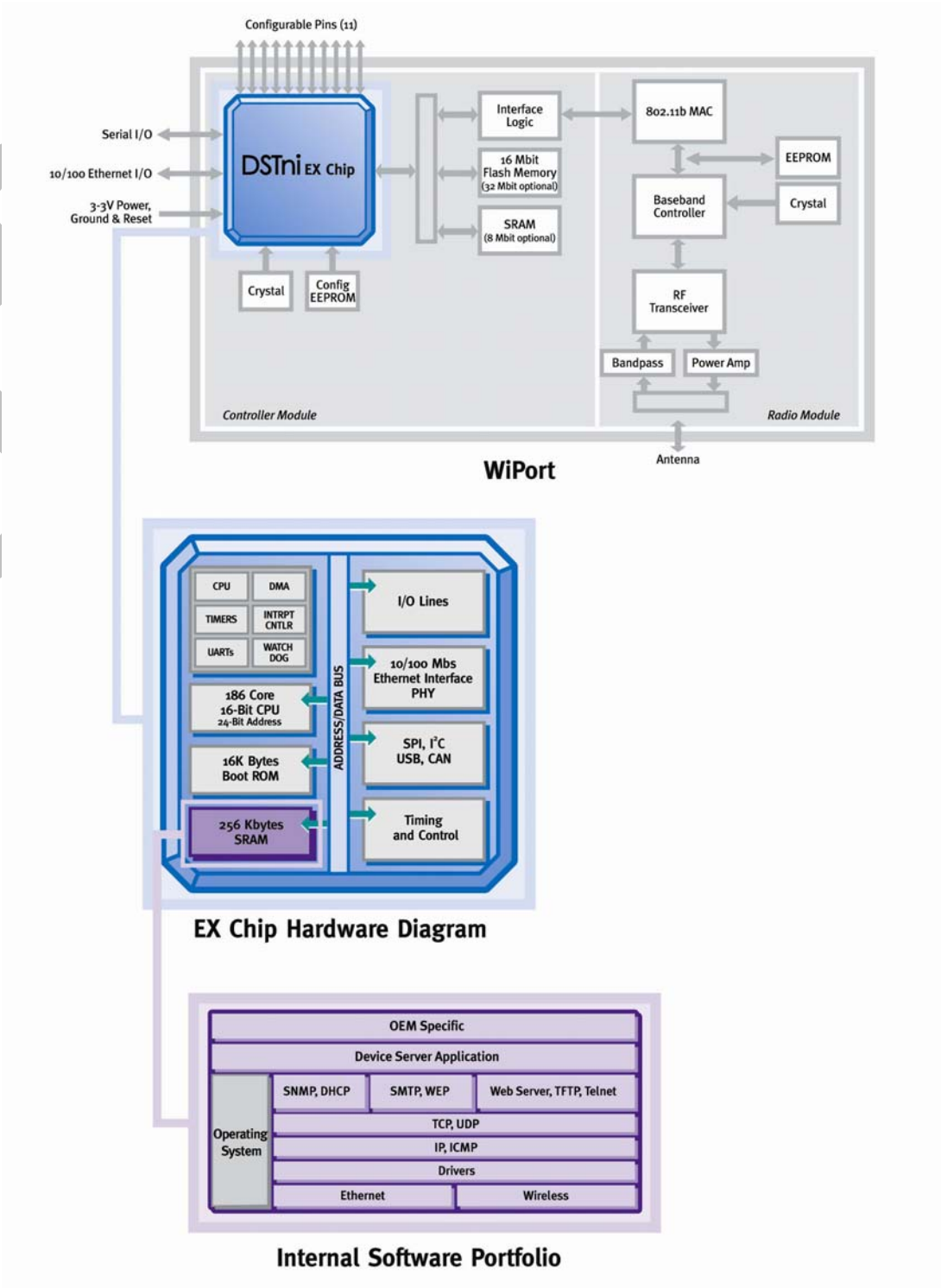

EX Chip Hardware Diagram

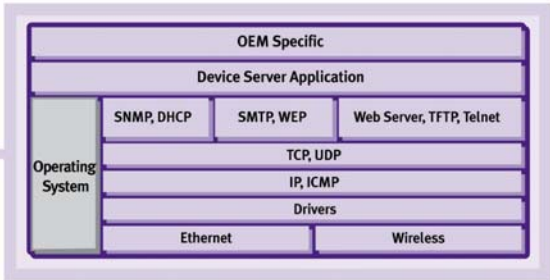

Internal Software Portfolio

PCB Interface

Table 2-1. PCB Interface Signals

Pin Number	WiPort Pin Function	Notes
1	3.3V Power	Supply input
2	3.3V Power	Supply input
3	RTS0	Request “to send” hardware flow control output (logic level), serial port 0
4	TXD0	Transmit data output (logic level), serial port 0
5	RXD0	Receive data input (logic level), serial port 0
6	CP2	Configurable pin
7	CP3	Configurable pin.
8	CTS0	Clear “to send” hardware flow control input (logic level), serial port 0
9	CP10	Configurable pin
10	CP8	Configurable pin
11	Signal Ground	
12	Signal Ground	
13	Reset In	Resets the WiPort unit. Reset In is low active. Minimum reset pulse width is 2ms at IIL = -500 μ A
14	CP0	Configurable pin
15	RTS1	Request “to send” hardware flow control output (logic level), serial port 1
16	TXD1	Transmit data output (logic level), serial port 1
17	RXD1	Receive data input (logic level), serial port 1
18	CP9	Configurable pin
19	CP4	Configurable pin
20	CTS1	Clear “to send” hardware flow control input (logic level), serial port 1
21	Reserved	Reserved for future use
22	Reserved	Reserved for future use
23	Signal Ground	
24	Signal Ground	
25	Reserved	Reserved for future use
26	Reserved	Reserved for future use
27	Ethernet Status LED2	Ethernet activity
28	Ethernet Status LED1	Ethernet link
29	Ethernet TX-	Output
30	Ethernet TX+	Output

Pin Number	WiPort Pin Function	Notes
31	Ethernet RX Center Tap	
32	Ethernet TX Center Tap	
33	Ethernet RX-	Input
34	Ethernet RX+	Input
35	CP1	Configurable pin
36	WLAN Power LED (WiPort B only)	High active output, tristated in Ethernet mode
37	CP6	Configurable pin
38	CP5	Configurable pin.
39	WLAN Activity LED	High active output, tristated in Ethernet mode
40	CP7	Configurable pin

Note: For all the configurable pins, see the WiPort User Guide for selectable functions.

Mating Connector

Table 2-2. Mating Connectors

Mating Connector	Description
Recommended: Samtec FTMH-120-03-F-DV-ES (shrouded header)	The mating connector is a 1mm micro header, 40 pins, 2 x 20.
Alternative: Samtec FTMH-120-03-F-DV (not shrouded)	
Alternative: Oupiin 2411-2X20GDN/017 (not shrouded)	

Serial Input/Output

The unit has two serial ports compatible with V24 serial standards at data rates up to 921Kbps. The serial I/O signals are 3.3V CMOS logic level and pins are 5V tolerant. Serial signals connect to an internal device, such as a UART. For evaluation and prototype work, it is convenient to have an external RS-232 interface that can connect to the serial port on a PC. The WiPort Evaluation Board has one RS-232 and one RS-232/422/485 transceiver (level shifters) to implement this external interface (only the WiPort 485 supports the RS-422/485 interface).

If desired, use the CPs to create a DTE or DCE-style interface using any 3 available CPs. To create these interfaces, connect the signals according to [Table 2-3](#) and [Table 2-4](#).

Note: CPx, CPy, and CPz are any of the available CPs.

Table 2-3. Channel 1 Connections

WiPort		DCE Connector		DTE Connector			
Signal	Description	DB9	DB25	Signal	DB9	DB25	Signal
RXD0	Data In	2	3	RXD0	3	2	TXD0
TXD0	Data Out	3	2	TXD0	2	3	RXD0
RTS0	H/W Flow Control Output	7	4	RTS0	8	5	CTS0
CTS0	H/W Flow Control Input	8	5	CTS0	7	4	RTS0
CPx	Modem Control Input	1	8	DCD	4	20	DTR
CPy	Modem Control Output	4	20	DTR	1	8	DCD
CPz	LED						

Table 2-4. Channel 2 Connections

WiPort		DCE Connector		DTE Connector			
Signal	Description	DB9	DB25	Signal	DB9	DB25	Signal
RXD1	Data In	2	3	RXD0	3	2	TXD1
TXD1	Data Out	3	2	TXD0	2	3	RXD1
RTS1	H/W Flow Control Output	7	4	RTS0	8	5	CTS1
CTS1	H/W Flow Control Input	8	5	CTS0	7	4	RTS1
CPx	Modem Control Input	1	8	DCD	4	20	DTR
CPy	Modem Control Output	4	20	DTR	1	8	DCD
CPz	LED						

Table 2-5. RS-422/485 4-Wire Connections

WiPort Signal	Description	DB25 Pinout	DB9 Pinout
TX+	TX+	14	7
TX-	TX-	15	3
RX+	RX+	21	2
RX-	RX-	22	8
RTS	TX Enable		
CPx	RS-485 Select		
CPy	RS-485 2-wire		
CPz	RS-485 4-wire		

Table 2-6. RS-485 2-Wire Connections

WiPort Signal	Description	DB25 Pinout	DB9 Pinout
TX+/RX+	TX+/RX+	14	7
TX-/RX-	TX-/RX-	15	3
RTS	TX Enable		
CPx	RS-485 Select		
CPy	RS-485 2-wire		
CPz	RS-485 4-wire		

Sample Layouts for RS-485 Connectivity

Figure 2-2. Combined RS-232/422 Transceiver

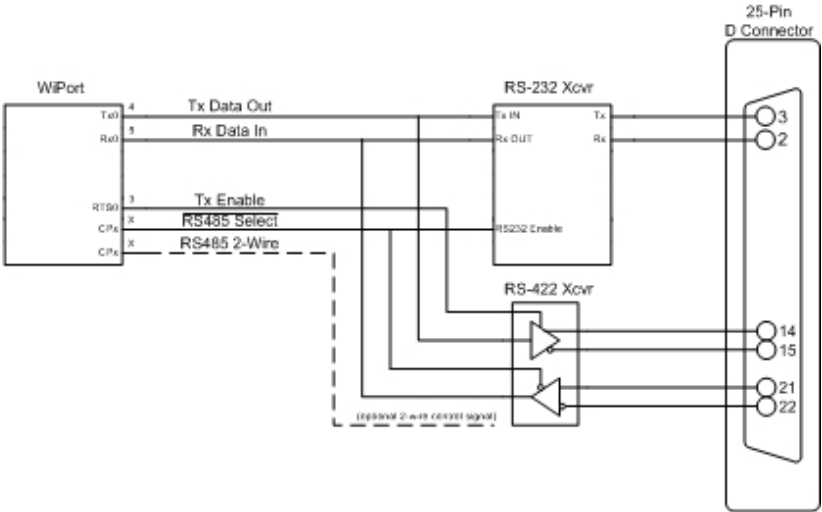

Figure 2-3. Separate RS-232/422 Transceivers

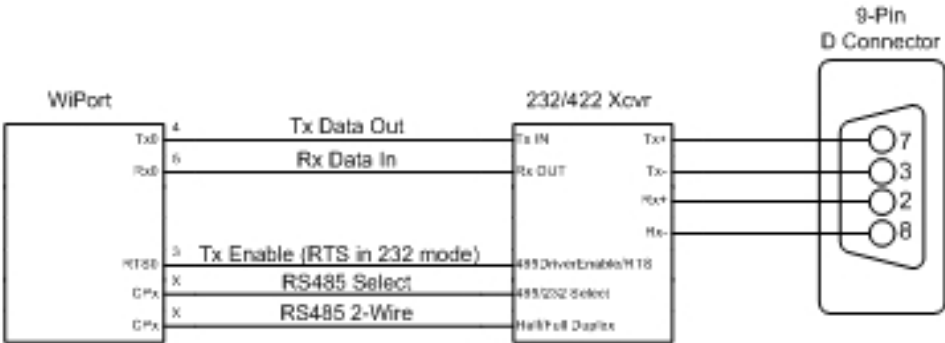
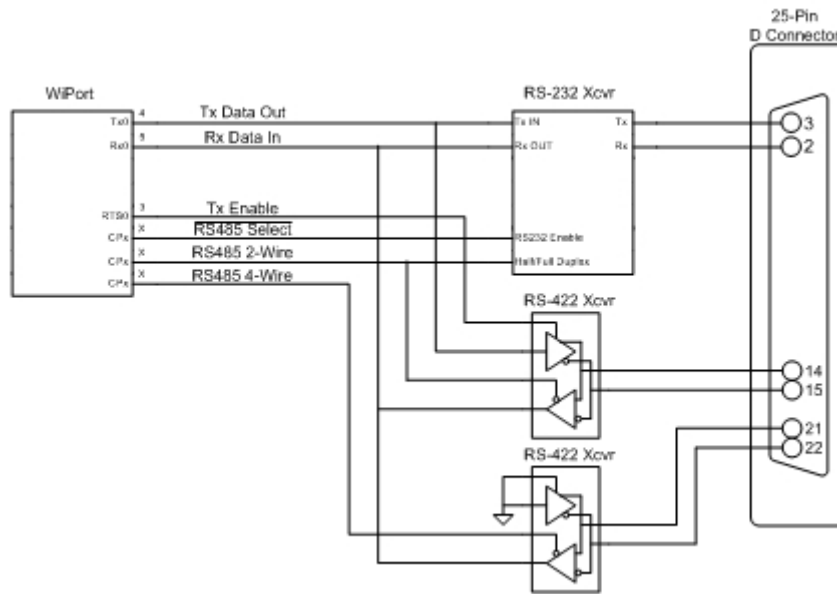

Figure 2-4. Separate RS-422 Transceivers for 2-Wire and 4-Wire Setups



WLAN Input/Output

The following table displays the WLAN input and output functions.

Table 2-7. WLAN Signals

Pin Number	Pin Function
36	WLAN Power LED
39	WLAN Activity LED

WLAN Power LED can be used to drive an external LED to monitor the status of the radio. When the WLAN Power LED is on continuously, it indicates the radio is on and in normal mode. When it is blinking, it indicates the radio is in power saving mode.

WLAN Activity LED is also used to drive an external LED to monitor the status of the radio. When the LED is blinking, it is receiving or transmitting wireless data. When it is off, it indicates there is no wireless activity.

Ethernet Input/Output

The following table displays the Ethernet input and output functions.

Table 2-8. Ethernet Signals

Pin Number	Pin Function
	<i>Ethernet</i>
30	TX+
29	TX-
32	TX Center Tap
34	RX+
33	RX-
31	RX Center Tap
28	Status LED1
27	Status LED2

Ethernet communication lines connect to external magnetics and an external RJ-45 jack. They are used for the creation of an Ethernet interface (instead of using the wireless interface). Either Ethernet or WLAN is selectable for communication (not both).

Ethernet Link LED 1 can be used to drive an external LED. The LED is on when a link exists.

Ethernet Activity LED 2 is also used to drive an external LED. The LED blinks when activity is present.

Power, Ground, and Reset

Table 2-9. Power, Ground, and Reset Pins

Power	Ground	Reset
Pin 1	Pin 11	Pin 13
Pin 2	Pin 12	
	Pin 23	
	Pin 24	

Driving the Reset In line low resets the WiPort. Minimum reset pulse width is 2ms at IIL = -500uA

Absolute Maximum Ratings

Table 2-10. Absolute Maximum Ratings

Parameter	Min	Max	Units
Supply Voltage	3.0	3.6	V
Input Voltage	-0.5	6	V
Output Voltage	-0.5	6	V
Operating Temperature	-30	70	°C
Storage Temperature	-40	85	°C

Recommended Operating Conditions

The following table illustrates the optimal and recommended operating conditions for the WiPort device.

Table 2-11. Operating Conditions, Serial Ports, & Configurable Pins

Parameter	Min	Typical	Max	Units
Supply Voltage	3.135	3.3	3.45	V
Voltage Ripple			2	%
VIL Input Low Voltage*	-0.3		0.8	V
VIH Input High Voltage*	2		5.5	V
II Input Leakage Current*		+/- 10 nA	+/- 1 µA	
VOL Output Low Voltage @ IOL max*			0.4	V
VOH Output High Voltage @ IOH max*	2.4			V
TXD0, RTS0, TXD1, RTS1 IOL Low Level Output Current @ VOL 0.4V	2.2	3.5	4.3	mA
CP0-CP10 Low Level Output Current @VOL 0.4V	4.4	7.1	8.5	mA
TXD0, RTS0, TXD1, RTS1 IOH High Level Output Current @ VOH 2.4V	-3.2	-6.4	-10.0	mA
CP0-CP10 IOH High Level Output Current @ VOH 2.4V	-6.4	-12.8	-20.0	mA

* For UART and CP pins

Ethernet PHY Receiver Input Characteristics (RX+, RX-)

Table 2-12. Ethernet Input Characteristics

Parameter	Specification	Units	Comments
Full Scale Input Voltage	3.0 differential pk-to-pk	V	
Input Common Mode	1.6 – 2.0	V	Gain dependent

100Base-TX Transceiver Characteristics (TX+, TX-)

The following table displays the 100Base-TX transceiver characteristics.

Table 2-13. 100Base-TX Transceiver Attributes

Parameter	Sym	Min	Typical	Max	Units
Peak Differential Output Voltage	VP	0.95		1.05	V
100M TX mid-level		-50		50	mV
Signal Amplitude Symmetry	VSS	98		102	%
Signal Rise/Fall Time	TRF	3.0		5.0	ns
Rise/Fall Time Symmetry	TRFS			0.5	ns
Duty Cycle Distortion	DCD	35	50	65	%
Overshot/Undershot	VOS			5	%
Jitter (measured differentially)				1.4	ns
Ethernet LED1, LED2 current		8.8	14.1	17.0	mA

Wireless Specifications

Refer to the following table for the WiPort's wireless specifications:

Table 2-14. Wireless Specifications

Category		EEE 802.11b	EEE 802.11g
Frequency Range		2.412 – 2.484 GHz	2.412 – 2.484 GHz
Output Power		14 +/- 1.0 dBm	14 +/- 1.0 dBm ≤ 12 Mbps 12 +/- 1.0 dBm > 12 Mbps
Antenna Connector		1	1
Data Rates		1,2,5.5,11 Mbps (802.11b HR)	1*,2*,5.5*,11*,6,9,12,18*,24*,36*,48,54* Mbps
Radio	Number of Selectable Subchannels**	US 1-11 CA 1-11 JP 1-14 FR 10-13 SP 10-11 OT 1-13 (OT=Others)	US 1-11 CA 1-11 JP 1-14 FR 10-13 SP 10-11 OT 1-13 (OT=Others)
	Modulation	DSSS,DBPSK K,DQPSK,C CK	DSSS,DBPSK, DQPSK,CCK, OFDM, 16QAM, 64QAM
	Antenna Connector	1	1
Security		WEP 64/128,WPA	WEP 64/128,WPA
Maximum Receive Level		10 dBm (with	10 dBm (with

Category	EEE 802.11b	EEE 802.11b
	PER < 8%)	PER < 8%)
Receiver Sensitivity	82 dBm for 11 Mbps 87 dBm for 5.5 Mbps 89 dBm for 2.0 Mbps 93 dBm for 1.0 Mbps	72 dBm for 54 Mbps 87 dBm for 11 Mbps 89 dBm for 5.5 Mbps 90 dBm for 2.0 Mbps 92 dBm for 1.0 Mbps
WLAN Power and Link LED Current	Max: 4 mA	Max: 4 mA

Technical Specifications

Table 2-15. Technical Specifications

Category	NiPort B	NiPort G
CPU, Memory	Lantronix DSTni-EX 186 CPU, 256 KB zero wait state SRAM 2048 KB Flash or 4096 KB Flash, 16 KB Boot ROM, 1024 KB SRAM	Lantronix DSTni-EX 186 CPU, 256 KB zero wait state SRAM 2048 KB Flash or 4096 KB Flash, 16 KB Boot ROM, 1024 KB SRAM
Firmware	Upgradeable via TFTP and serial port	Upgradeable via TFTP and serial port
Reset Circuit	Reset In is low active. Minimum reset pulse width is 2 ms at IIL = -500 μ A	Reset In is low active. Minimum reset pulse width is 2 ms at IIL = -500 μ A
Serial Interface	CMOS (Asynchronous) 3.3V - level signals Speed software selectable (300 bps to 921600 bps)	CMOS (Asynchronous) 3.3V - level signals Speed software selectable (300 bps to 921600 bps)
Serial Line Formats	7 or 8 data bits, 1-2 Stop bits, Parity: odd, even, none	7 or 8 data bits, 1-2 Stop bits, Parity: odd, even, none
Modem Control	DTR, DCD	DTR, DCD
Flow Control	XON/XOFF (software), CTS/RTS (hardware), none	XON/XOFF (software), CTS/RTS (hardware), none
Network Interface	802.11b and 10/100 Ethernet	802.11b/g and 10/100 Ethernet
Protocols Supported	ARP, UDP, TCP, Telnet, ICMP, SNMP, DHCP, BOOTP, Auto IP, HTTP, SMTP, TFTP	ARP, UDP, TCP, Telnet, ICMP, SNMP, DHCP, BOOTP, Auto IP, HTTP, SMTP, TFTP
Management	Internal web server, SNMP (read only) Serial login, Telnet login, DeviceInstaller software	Internal web server, SNMP (read only) Serial login, Telnet login, DeviceInstaller software
Internal Web Server	Serves web pages WEB storage capacity: 1.2 MB (or 3.2 MB)	Serves web pages WEB storage capacity: 1.2 MB (or 3.2 MB)
Distance	Up to 328 feet Indoors	Up to 328 feet Indoors
Average Power Consumption (at 3.3V)	Wireless Mode Associated 1200 mW (High performance. Data transfer at 922 kbps.) 900 mW (Regular performance. Data transfer at 230 kbps.) 550 mW (High performance. No data transfer.) 400 mW (Regular performance. No data transfer.) 250 mW (Low performance. No data transfer.) Ethernet Mode 750 mW (Regular performance. No data transfer.)	Wireless Mode Associated 1300 mW (High performance. Data transfer at 922 kbps.) 950 mW (Regular performance. Data transfer at 230 kbps.) 580 mW (High performance. No data transfer.) 430 mW (Regular performance. No data transfer.) 300 mW (Low performance. No data transfer.) Ethernet Mode 750 mW (Regular performance. No data transfer.)
Peak Supply Current (at 3.3V)	420 mA	650 mA
Security	Password protection, locking features, 64/128 bit WEP, WPA	Password protection, locking features, 64/128 bit WEP, WPA
Weight	29 grams	29 grams
Material	Metal shell	Metal shell
Temperature	Operating range: -30°C to +70°C Storage range: -40°C to +85°C (-40°F to 185°F)	Operating range: -30°C to +70°C Storage range: -40°C to +85°C (-40°F to 185°F)
Warranty	2-year limited warranty	2-year limited warranty

Category	NiPort B	NiPort G
Included Software	Windows™ 98/NT/2000/XP based Device Installer configuration software and Windows™ based Comm Port Redirector, DeviceInstaller, Web-Manager.	Windows™ 98/NT/2000/XP based Device Installer configuration software and Windows™ based Comm Port Redirector, DeviceInstaller, Web-Manager.

Dimensions

The WiPort dimensions are shown in the following diagrams:

Figure 2-5. Side Views

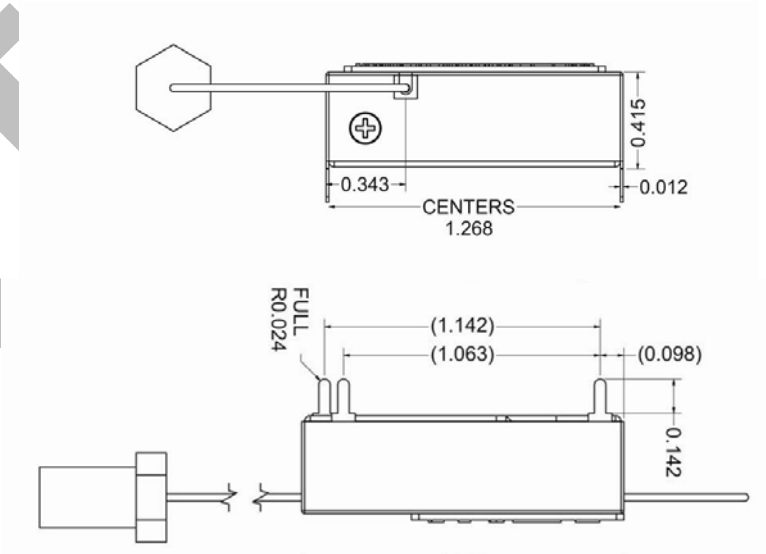

Figure 2-6. Top View

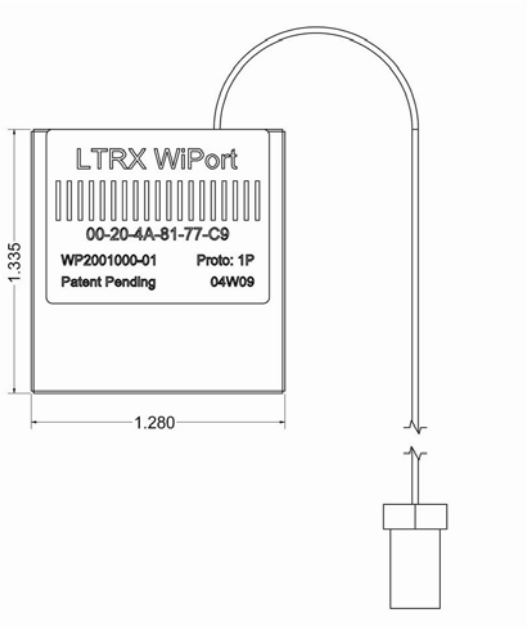
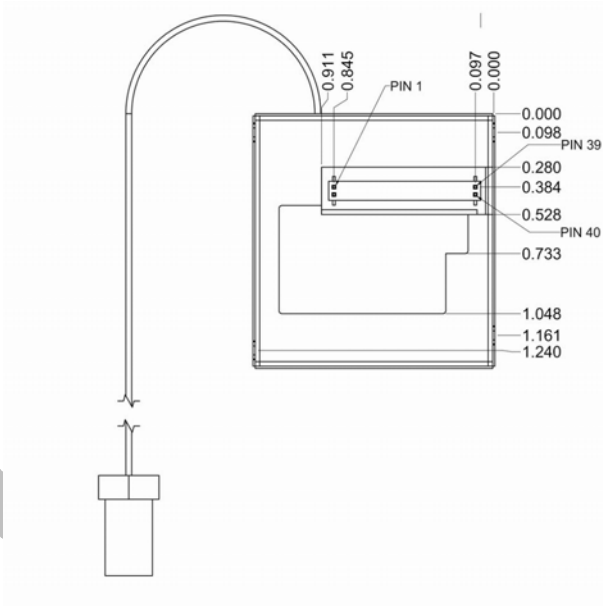

Figure 2-7. Bottom View



Recommended PCB Layout

The hole pattern and mounting dimensions for the WiPort device server are shown in the following drawing:

Figure 2-8. PCB Layout

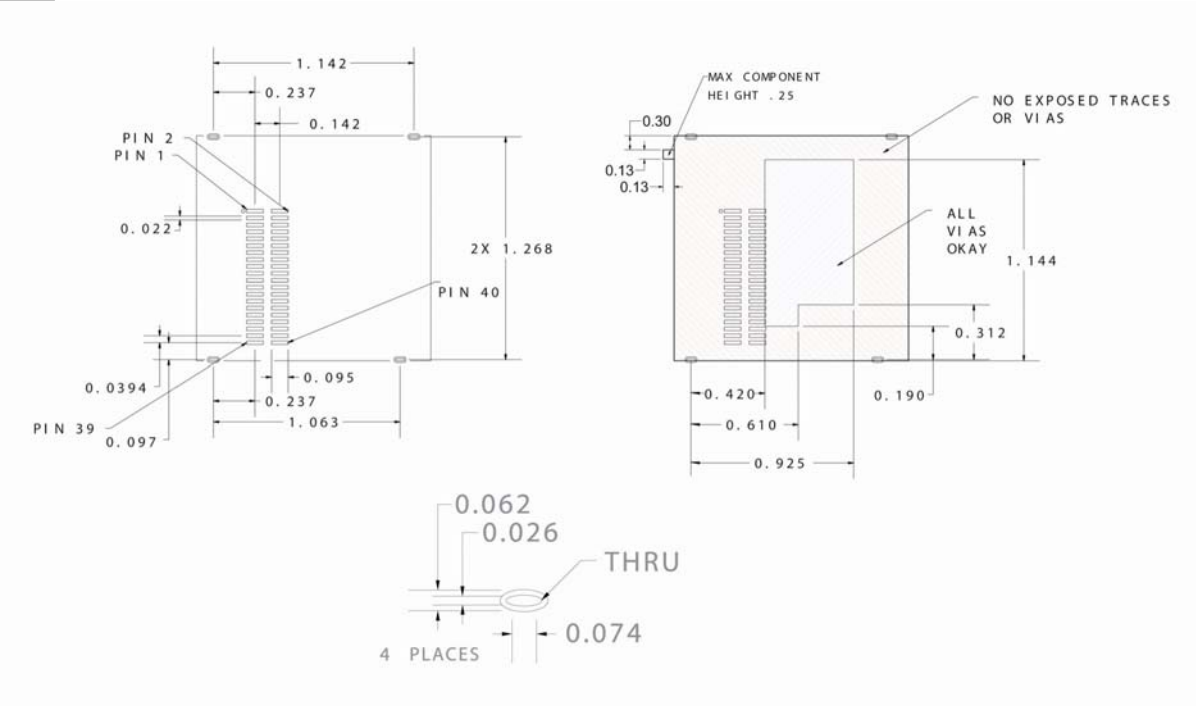

Product Information Label

The product information label contains important information about your specific unit, such as its product ID (name), bar code, part number, and MAC address.

Figure 2-9. Product Label

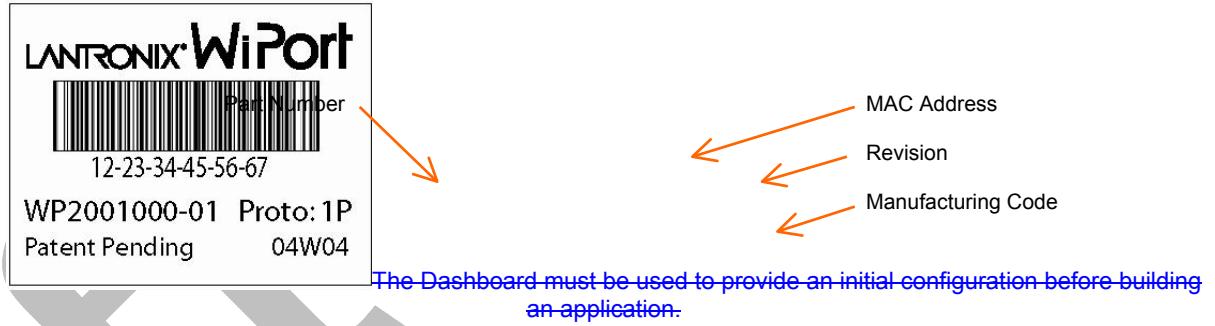

3.3: Development Kit

The WiPort Development Kit includes everything needed to begin to integrate the WiPort into a given product design.

Contents of the Kit

The development kit contains the following items:

- ◆ WiPort Evaluation Board
- ◆ WiPort Device Server
- ◆ 3.3V Power Supply
- ◆ RS-232 cable, DB9F/F, null modem
- ◆ CAT5e UTP RJ45M/M Ethernet cable
- ◆ CD with software utilities and documentation (in PDF format)
- ◆ Antenna

3.4 Evaluation Board Description

The WiPort Evaluation Board provides a test platform for the Lantronix WiPort device server. It supplies 3.3V power. The WiPort Evaluation Board provides access to all signals to and from the WiPort device server. For connecting to an external device, the Evaluation Board two serial ports (DTE).

An on-board Complex Programmable Logic Device (CPLD) drives status LEDs and configures external connections.

Note: *Either disregard WLAN POWER and WLAN ACTIVITY LEDs in the Ethernet Mode or add 15K resistors between test header J2 pin 36 and GND, and pin 39 and GND. With these resistors, LEDs are OFF in the Ethernet Mode*

Serial Interfaces

The WiPort serial interfaces are 3.3V logic level and typically connected to a Universal Asynchronous Receiver/Transmitter (UART). For connection to an external device, the evaluation board has RS-232 and RS-232/422/485 transceivers. Port 0 supports RS-232. Port 1 (channel 2) supports RS-232/485. Connect to a PC using a null-modem serial cable with 9-pin connectors (F/F).

The table below lists the RS-232 signals and corresponding pins on the WiPort. Note that the WiPort data and hardware flow control signals are actually buffered by the evaluation board CPLD. All signals are level-shifted by the RS-232 transceivers.

Table 3-1. RS-232 Signals

WiPort PIN FUNCTION	DB9 Pin #
UART 0	
TXD0 (Data Out)	3
RXD0 (Data In)	2
CTS0 (HW Flow Control Input)	8
RTS0 (HW Flow Control Output)	7
DCD0 (Modem Control Input)	1
DTR0 (Modem Control Output)	4
UART 1	
TXD1 (Data Out)	3
RXD1 (Data In)	2
CTS1 (HW Flow Control Input)	8
RTS1 (HW Flow Control Output)	7
DCD1 (Modem Control Input)	1
DTR1 (Modem Control Output)	4

Table 3-2. Channel 2 RS-485 4-Wire Connector

WiPort Signal	Description	DB9 Pin Number
TX+	Data Out	7
TX-	Data Out	3
RX+	Data In	2
RX-	Data In	8

Table 3-3. Channel 2 RS-485 2-Wire Connector

WiPort Signal	Description	DB9 Pin Number
TX+/RX+	Data Out/In	7
TX-/RX-	Data Out/In	3

Power Supply

The evaluation board uses an external 3.3V regulated supply (included with kit). The evaluation board contains additional filtering and protection.

General Control PLD

The following table denotes the configuration of the evaluation board. Configuring the jumper re-routes the signals on the evaluation board as required for a given product. This also drives the LEDs.

Configuration Switch Bank

Table 3-4. Jumper Configurations

Jumpers	Details
JP1 in and JP2 in	CP10 and CP4 connected to RS-232 transceiver; can function as DTR1 and DCD1.
JP1 in and JP2 in JP1 out and JP2 out	CP10 and CP4 not connected to RS-232 transceiver; can function as general purpose I/O pins.

Evaluation Board Schematics

Figure 3-2. Evaluation Board Schematics

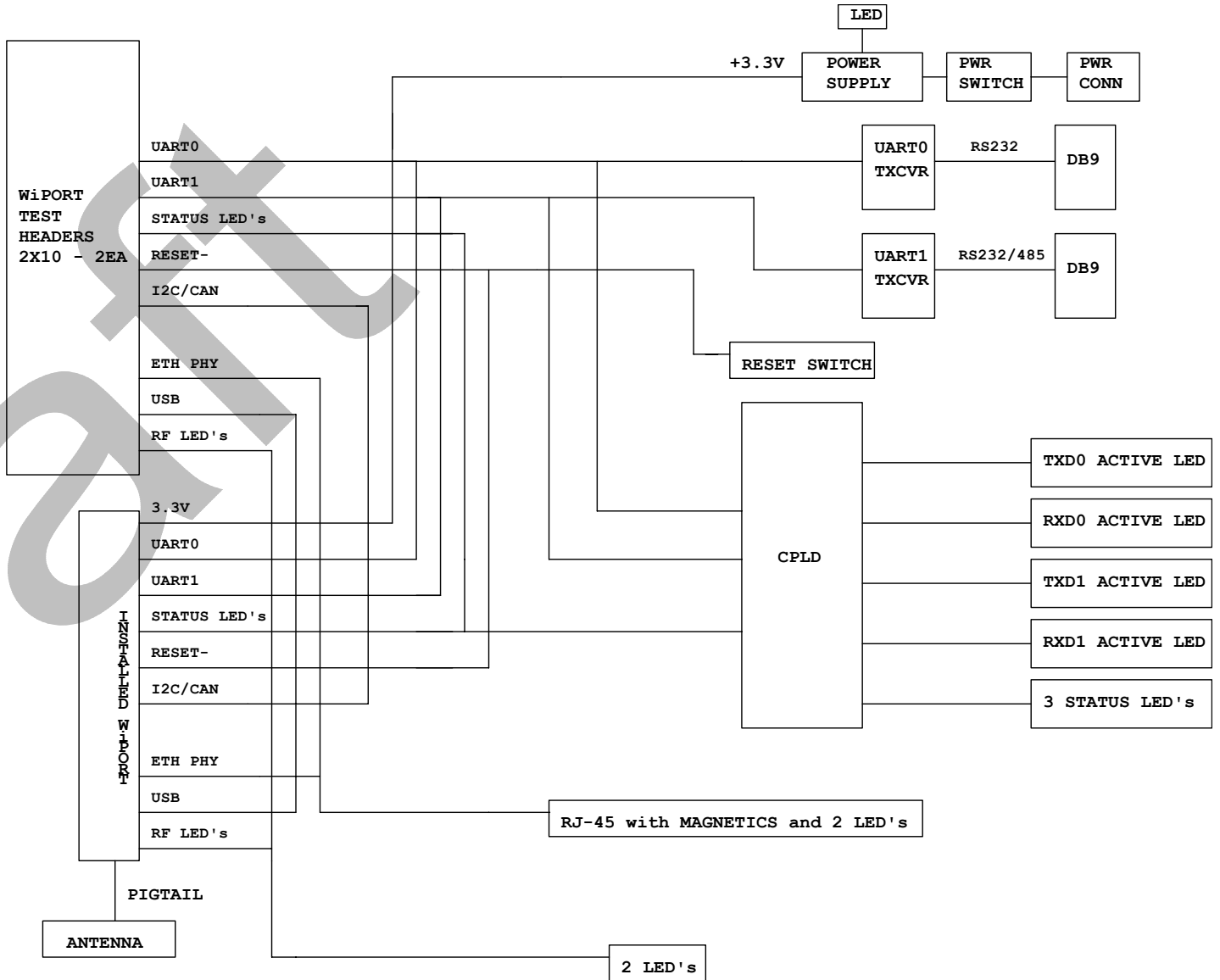

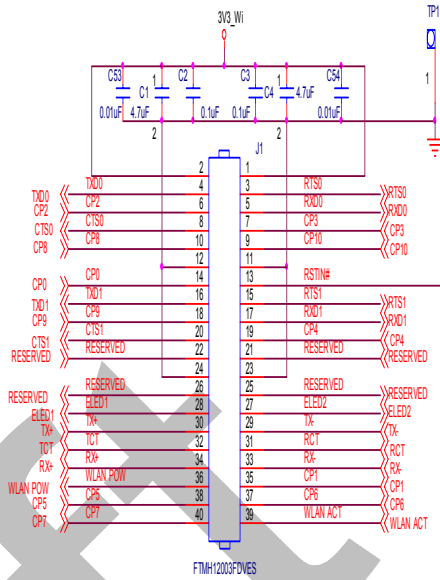

Place C1,C2, C53 close to J1 pin 1
Place C3,C4, C54 close to J1 pin 2

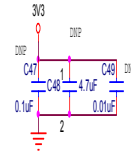

Wiport Connector

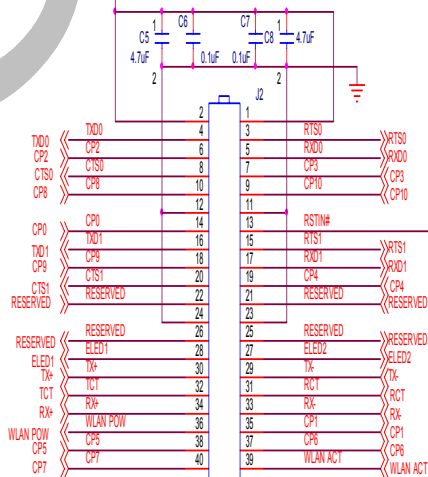
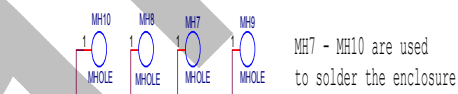

Test Header for WiPort I/O

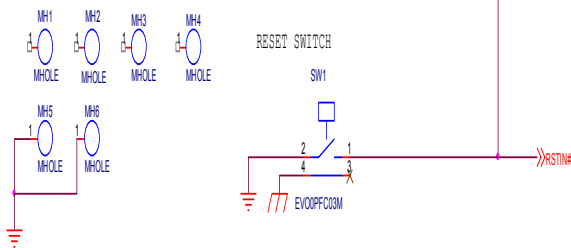

Ethernet RJ-45

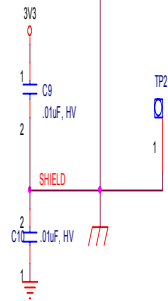
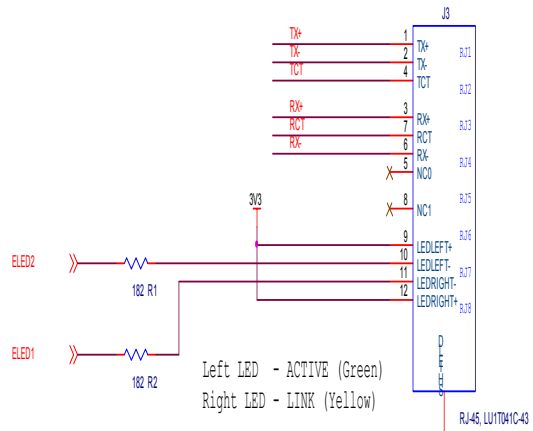

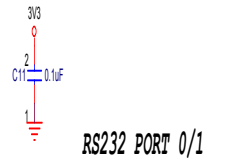

RS232 PORT 0/1

In RS485 mode,
RTS1 is used to
enable the RS485
output driver

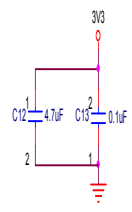

RS232/RS485 PORT 1

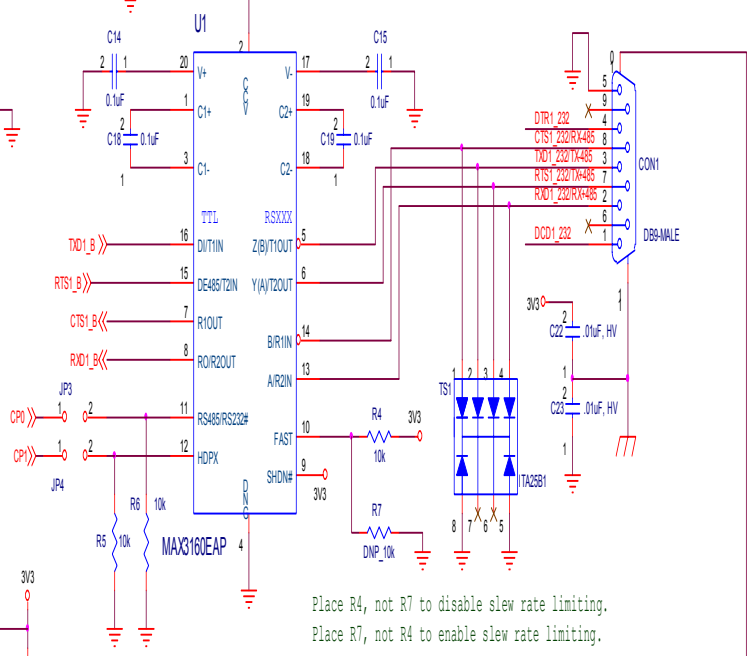
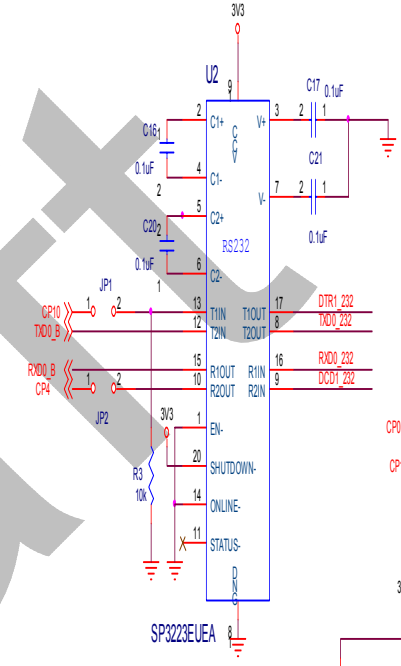

Place R4, not R7 to disable slew rate limiting.
Place R7, not R4 to enable slew rate limiting.

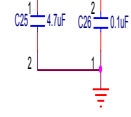

RS232 PORT 0

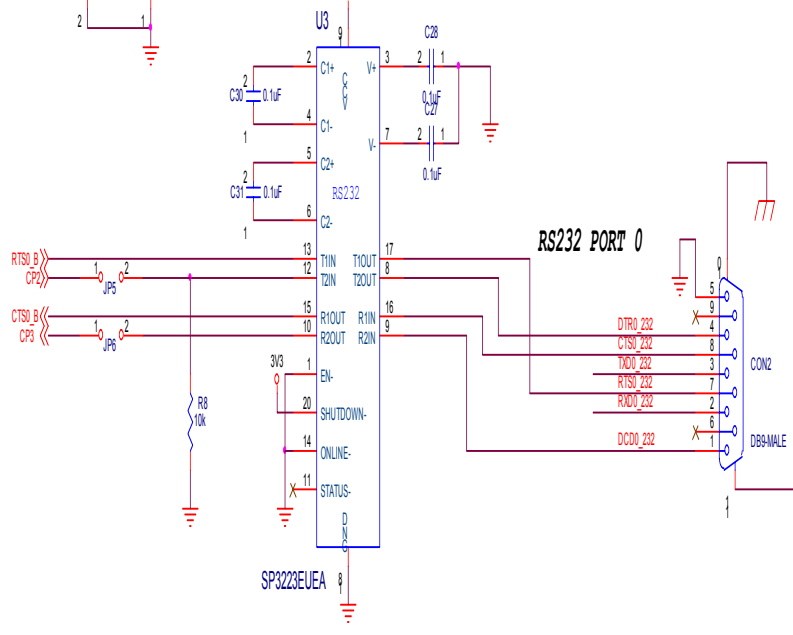

DNP = Do Not Place

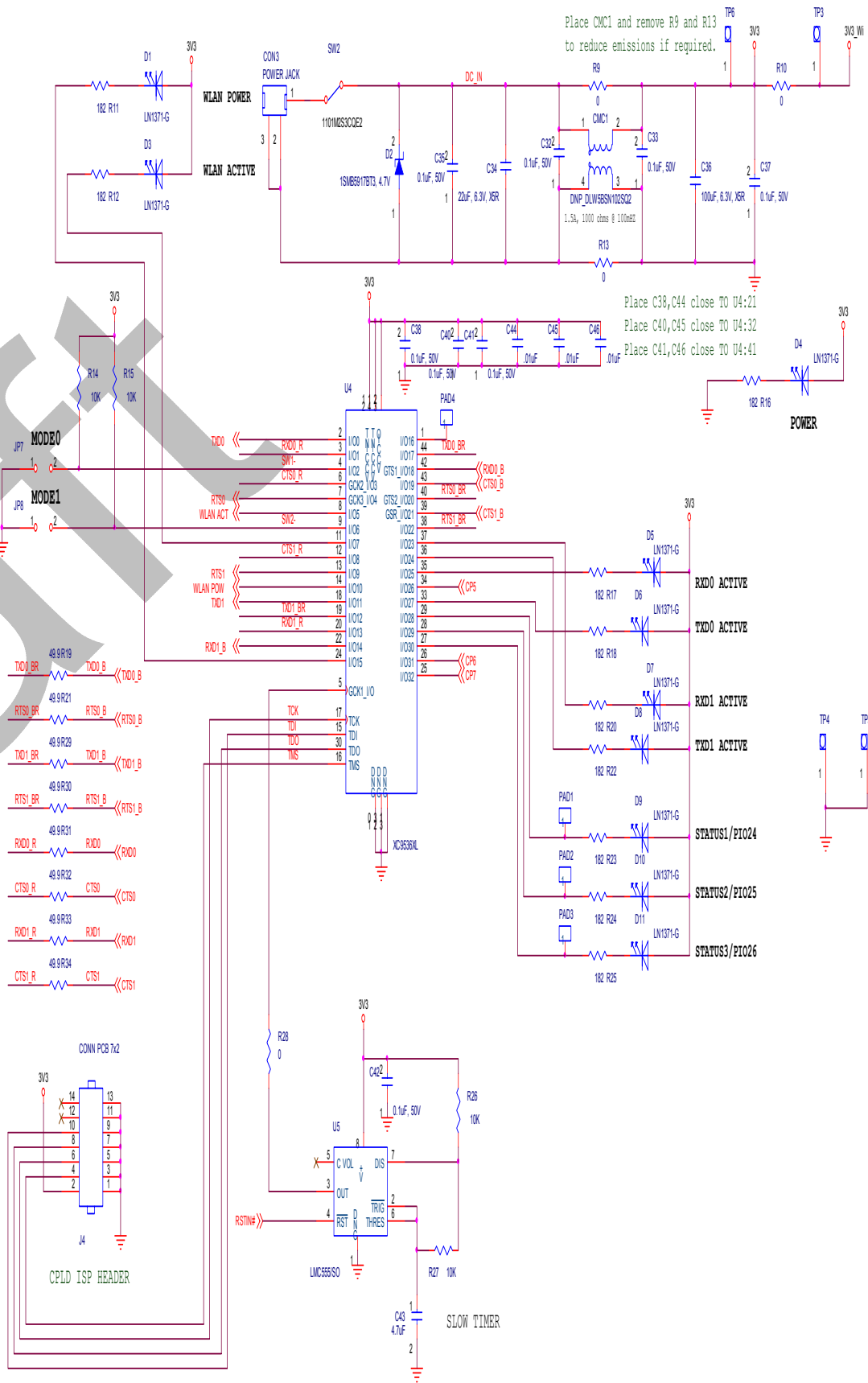

A: Compliance and Warranty Information

Compliance Information

(According to ISO/IEC Guide 22 and EN 45014)

Manufacturer's Name & Address:

Lantronix 15353 Barranca Parkway, Irvine, CA 92618 USA

Declares that the following product:

Product Name Model: WiPort Embedded Device Server

Conforms to the following standards or other normative documents:

Safety:

UL 60950:2003

CAN/CSA-C22.2 No. 60950:2003

EN 60950:2003 +A1-A4, A11 , Low Voltage Directive (73/23/EEC)

EMC & Radio:

For purposes of certification, the WiPort was tested as a modular device.

CFR Title 47 FCC Part 15, Subpart **B and C**, Class B

FCC Module Approval

FCC Identifier: R68WIPORT**G**

Industry Canada ICES-003 Issue 4 (2004), Class B

Industry Canada RSS-Gen Issue 1 (2005)

Industry Canada RSS-210 Issue 6 (2005)

Industry Canada Module Approval IC: **3867A-WIPORTG**

EN 301 489-1 v1.4.1 (2002-08) , EMC Directive (**1999/5/EC**)

EN 301 489-17 v.1.2.1 (2002-08) , EMC Directive (**1999/5/EC**)

EN 300 328 v1.4.1 (2003-04), R&TTE Directive (1999/5/EC)

Australia / New Zealand AS/NZS CISPR 22 (**2006**), Class B

Australia / New Zealand AS/NZS 4771 (2000 + A1:2003)

Japan VCCI (EMC emissions) **V-3/2006-04**

EN55022: 1998 + A1: 2000 + A2: 2003

EN55024: 1998 + A1: 2001 + A2: 2003

EN61000-3-2: 2000 + A2: 2005

EN61000-3-3: 1995 + A1: 2001

Warranty

Lantronix warrants each Lantronix product to be free from defects in material and workmanship for a period of TWO YEARS. During this period, if a customer is unable to resolve a product problem with Lantronix Technical Support, a Return Material Authorization (RMA) will be issued. Following receipt of a RMA number, the customer shall return the product to Lantronix, freight prepaid. Upon verification of warranty, Lantronix will -- at its option -- repair or replace the product and return it to the customer freight prepaid. If the product is not under warranty, the customer may have Lantronix repair the unit on a fee basis or return it. No services are handled at the customer's site under this warranty. This warranty is voided if the customer uses the product in an unauthorized or improper way, or in an environment for which it was not designed.

Lantronix warrants the media containing its software product to be free from defects and warrants that the software will operate substantially according to Lantronix specifications for a period of 60 DAYS after the date of shipment. The customer will ship defective media to Lantronix. Lantronix will ship the replacement media to the customer.

In no event will Lantronix be responsible to the user in contract, in tort (including negligence), strict liability or otherwise for any special, indirect, incidental or consequential damage or loss of equipment, plant or power system, cost of capital, loss of profits or revenues, cost of replacement power, additional expenses in the use of existing software, hardware, equipment or facilities, or claims against the user by its employees or customers resulting from the use of the information, recommendations, descriptions and safety notations supplied by Lantronix. Lantronix liability is limited (at its election) to:

- ◆ Refund of buyer's purchase price for such affected products (without interest).
- ◆ Repair or replacement of such products, provided that the buyer follows the above procedures.

There are no understandings, agreements, representations or warranties, expressed or implied, including warranties of merchantability or fitness for a particular purpose, other than those specifically set out above or by any existing contract between the parties. Any such contract states the entire obligation of Lantronix. The contents of this document shall not become part of or modify any prior or existing agreement, commitment or relationship.

For details on the Lantronix warranty replacement policy, go to our web site at www.lantronix.com/support/warranty