

**linear
motion
systems**



Cinema Seat Mass Open/Close Wall Box Transmitter Product Specification



Warning

The socket-outlet shall be installed near the equipment and shall be easily accessible!

FCC Statement

This device complies with Part 15 of the FCC Rules. Operation is subject to the following two conditions:

- (1) This device may not cause harmful interference, and
- (2) This device must accept any interference received, including interference that may cause undesired operation.

Any changes or modifications not expressly approved by party responsible for compliance could void the user's authority to operate the equipment.

Note: This equipment has been tested and found to comply with the limits for a Class B digital device, pursuant to part 15 of the FCC Rules. These limits are designed to provide reasonable protection against harmful interference in a residential installation. This equipment generates, uses and can radiate radio frequency energy and, if not installed and used in accordance with the instructions, may cause harmful interference to radio communications. However, there is no guarantee that interference will not occur in a particular installation. If this equipment does cause harmful interference to radio or television reception, which can be determined by turning the equipment off and on, the user is encouraged to try to correct the interference by one or more of the following measures:

- Reorient or relocate the receiving antenna.
- Increase the separation between the equipment and receiver.
- Connect the equipment into an outlet on a circuit different from that to which the receiver is connected.
- Consult the dealer or an experienced radio/TV technician for help."

This equipment should be installed and operated with minimum distance 20cm between rotation & your body.

RSS-Gen & RSS-210 Statement:

"This device complies with Industry Canada licence-exempt RSS standard(s).

Operation is subject to the following two conditions: (1) this device may not cause interference, and (2) this device must accept any interference, including interference that may cause undesired operation of the device.

Le présent appareil est conforme aux CNR d'Industrie Canada applicables aux appareils radio exempts de licence. L'exploitation est autorisée aux deux conditions suivantes : (1) l'appareil ne doit pas produire de brouillage, et (2) l'utilisateur de l'appareil doit accepter tout brouillage radioélectrique subi, même si le brouillage est susceptible d'en compromettre le fonctionnement."

RSS-102 Statement:

"This equipment complies with Industry Canada radiation exposure limits set forth for an uncontrolled environment. "

"Cet équipement est conforme à l'exposition aux rayonnements Industry Canada limites établies pour un environnement non contrôlé. "

Description

This system is designed for cinema seats mass open and close. With one wall unit box could control up 100 sets seats open and close at one time.

Technical Parameter

Mass Open and Close Wall Box

Model: HC371

Article No.: 501958

Dimension:250x200x100mm

Input: 29Vdc, Max. 0.1A

Backup Battery: 18V (2x 6LR61)

Wireless Parameters

- RF Frequency: 2.4GHz
- Working mode: Broadcasting only
- Control Range: >50m in open space

Connection:

- Antenna Connector: SMA female

Key lock switch

- 2 position on and off with key

Display

- 16 characters x 2 Row

Certification:

- CE/FCC/cTUVs/

Description for system

1. Front panel

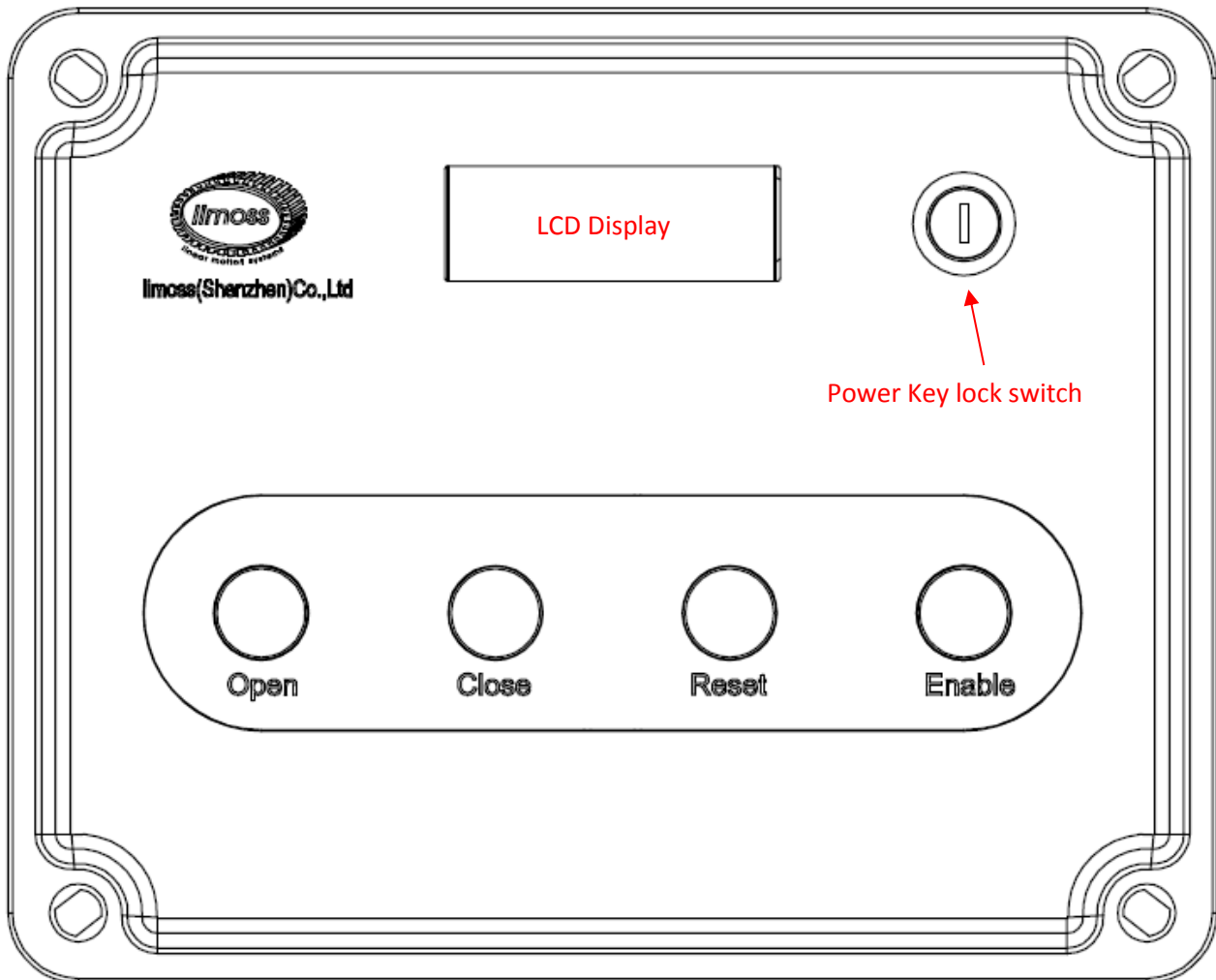

2. Top side: SMA Antenna Connector

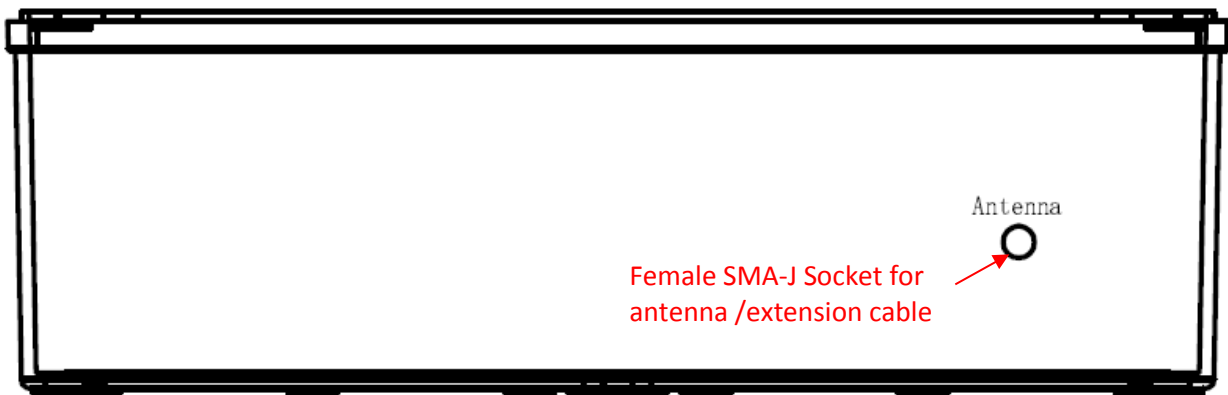

3. DC Input with PG7 Connector

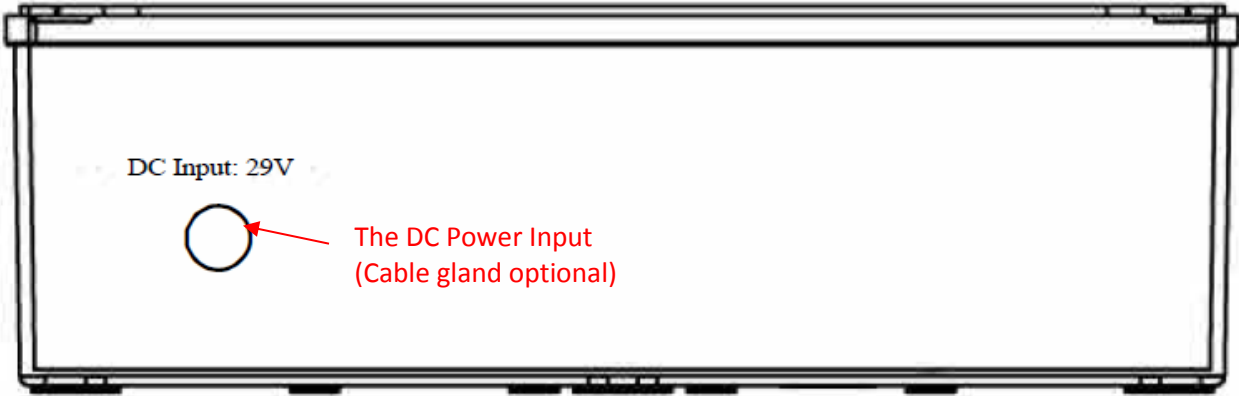

4. Inside Box

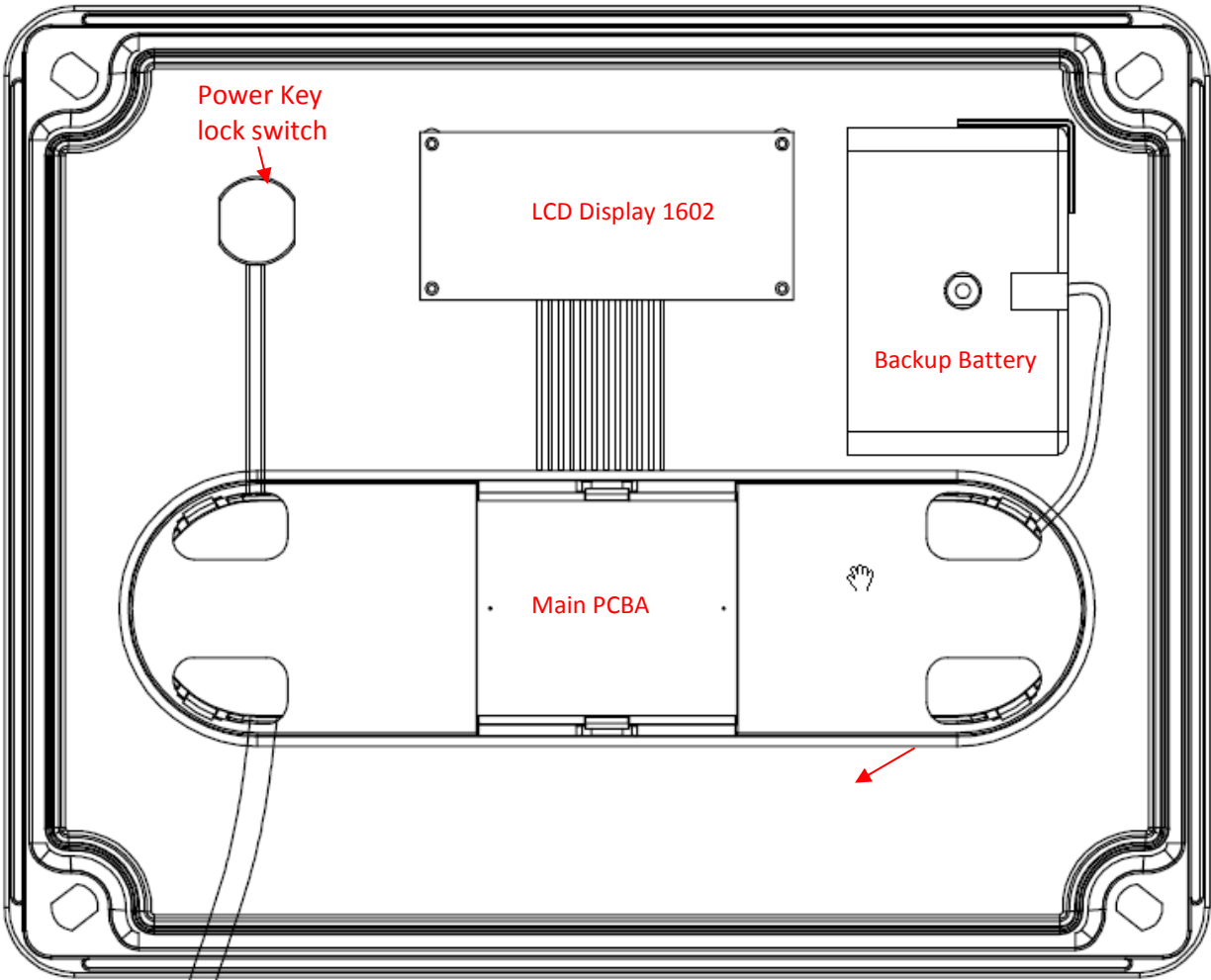

6. Accessory

- 2.4GHz 5dBi antenna x1

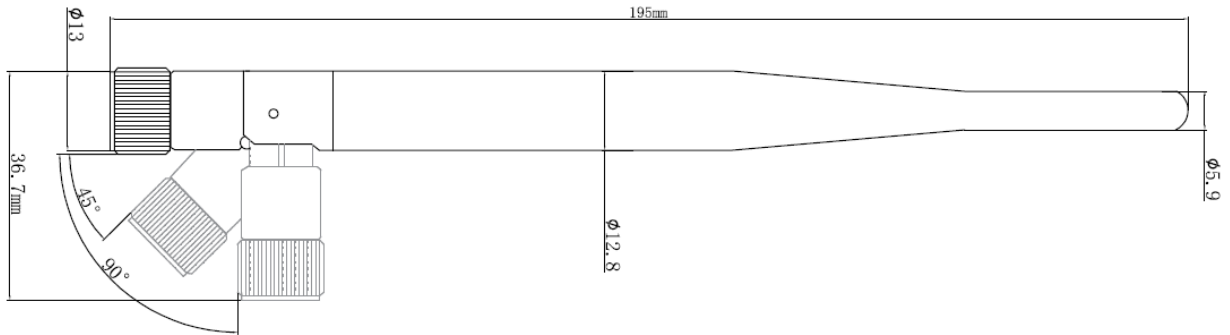

- Antenna Extension Cable 2m x1

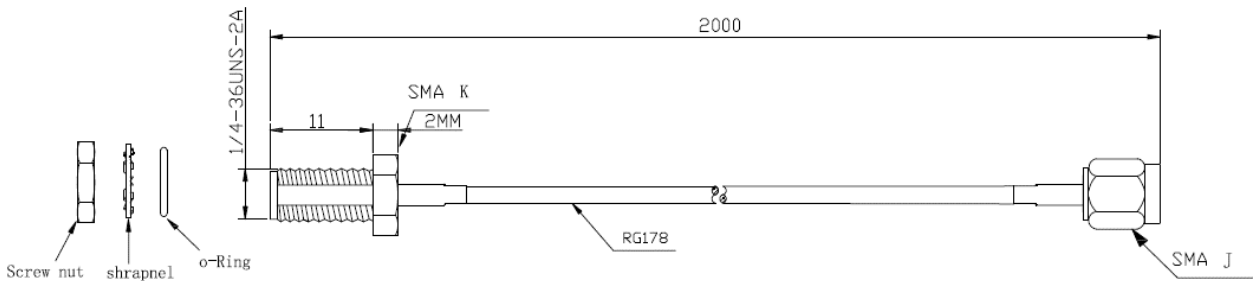

- Antenna Front Panel

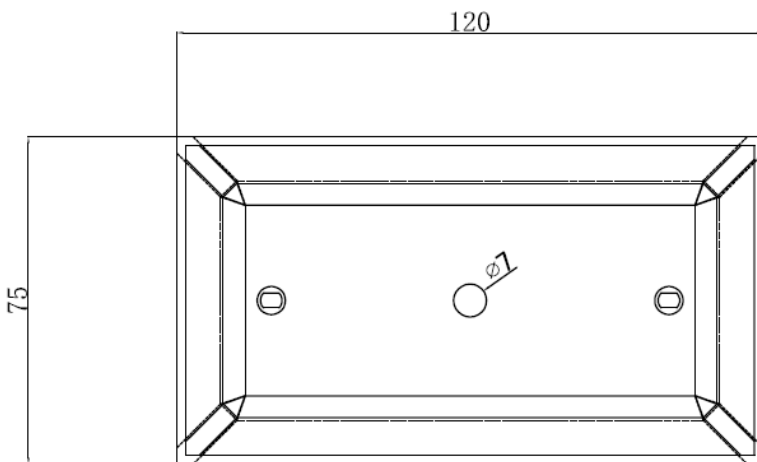

- The way to assemble the face plate with antenna and extension cable.

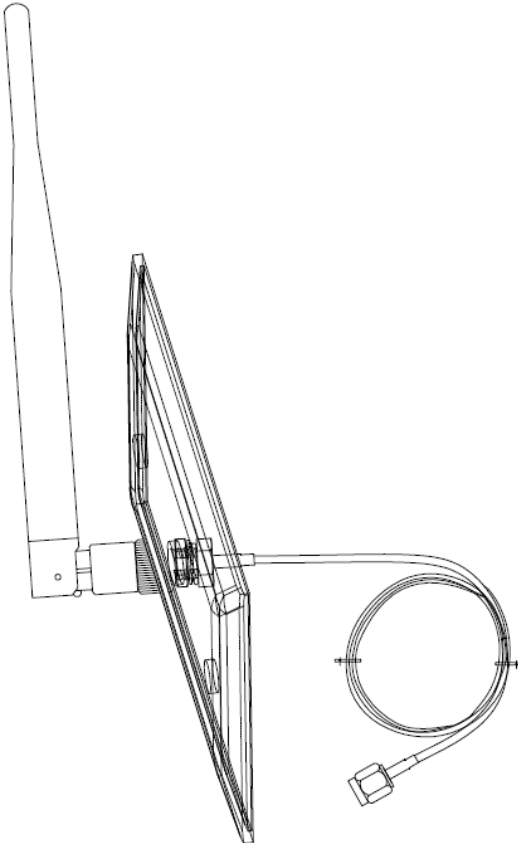

Label

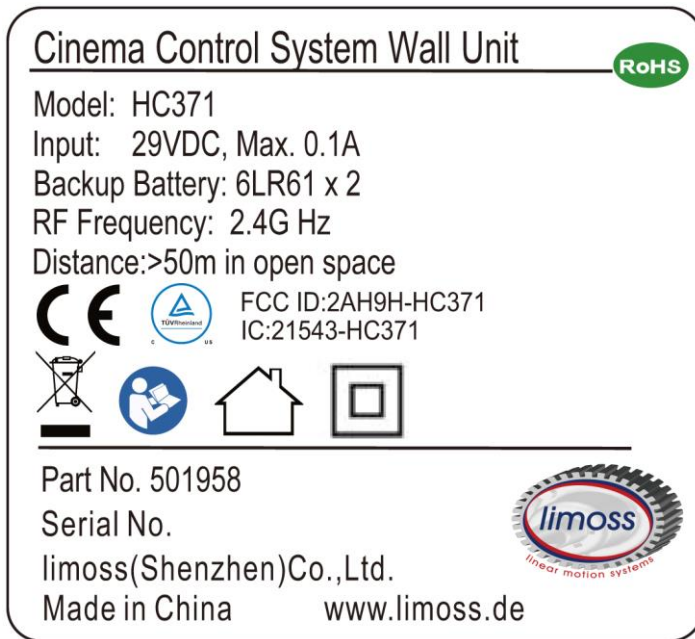

Operation Instruction:

Before all operation, please connect transmitter box to DC power, plug the receiver box MC250 to L1 actuator , and turn the key lock to position “On”.

The display will show information if power on and initialization correct.

Pairing

1. Transmitter box:

- Presse Open/Close/Enable at the same time, the display will show : “Enter the paring mode”, and counter for 3 s to enter.
- Press any key will exit paring mode

2. Receiver box

There are two method to make the pairing

- When power on, there is 5 seconds in pairing model, once received pairing signal from transmitter , the pairing will execute automatically , he motor will drive out and in for twice in 4 seconds, then the paring is finished.
- press both buttons of handset for 5 seconds, if transmitter box is in paring mode, the motor will drive out and in for twice in 4 seconds, then the paring is finished.

Operation:

- Press Open + Enable to let all seats open
- Press Close n + Enable to let all seats Close

Remark:

If turning the key switch 2.5 times within 1 seconds, the operation will be disabled for 5 s, and the working LED indicator will be flashing to prevent user playing with the system.

Revised history

Item	Change content	Index	Revised date
1	First issue	00	2017/2/19
2.	Update drawing and operation	01	2017/2/25