



Description

Prefill and Exhaust valves model **PV**** are seat type check valves, allowing free flow from its port **A** to port **B** and leak-free closure in opposite direction. For reverse flow, these valves can be opened by applying pilot pressure to its port **X**.

The valves are designed for the purpose of pre-filling large cylinders during their rapid approach motions, which are actuated mean like a pair of kicker cylinders or jack up cylinders or by gravitational force.

These valves have very low cracking pressure and generous internal passage to help them to offer least possible pressure drop while pre-filling.

Due to low pressure drop, these valves also can handle much higher exhaust flow enabling rapid return of the cylinders.

For connectivity, it's **A** port is machined as per Port dimensions for Flanged connection ISO 6162.

The special cavity for the **B** port helps the user to mount these valves directly on the cylinders, thus further reducing the pressure drop in the line.

A hydraulic system having Prefill valve without decompression feature, must have an external arrangement of decompressing the oil in the cylinder, before the valve is opened.



Section

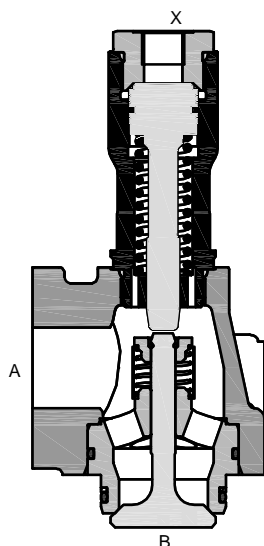

Prefill valve without decompression feature

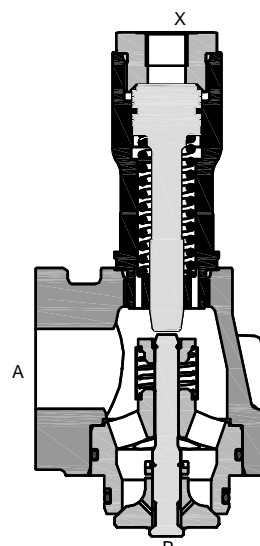

Prefill valve with decompression feature

Hydraulic symbol

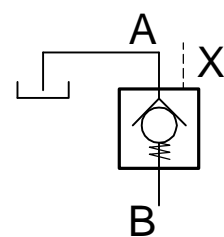



Unit dimensions

Dimensions in mm.

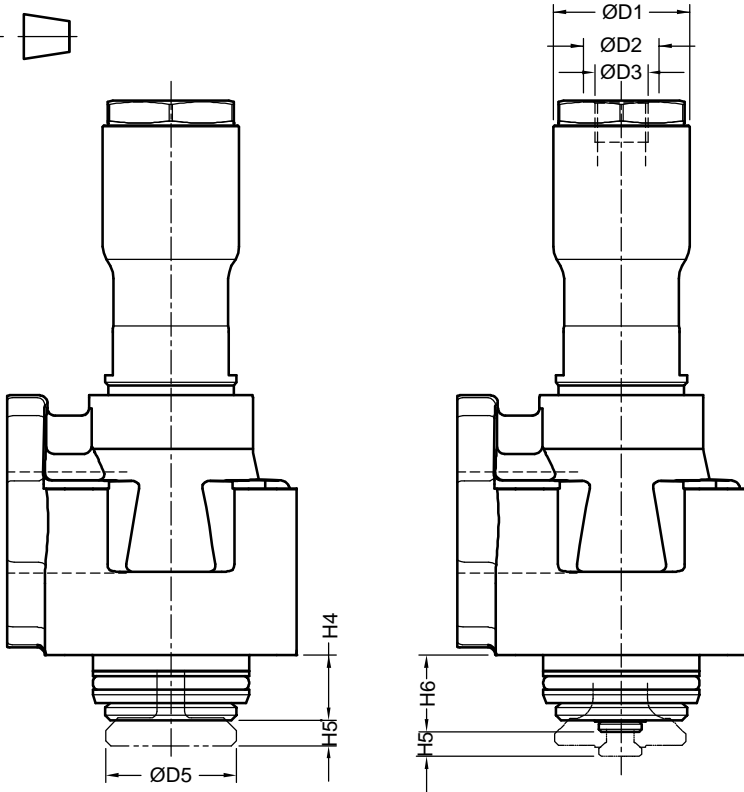
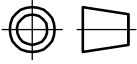

Prefill valve without decompression feature

Prefill valve with decompression feature

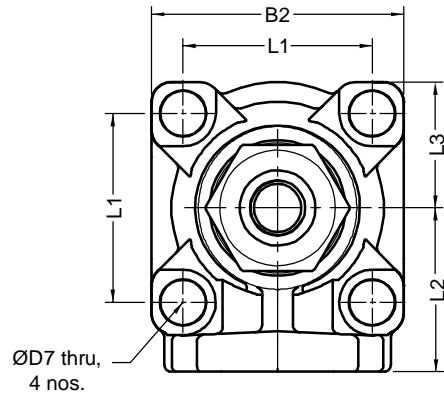
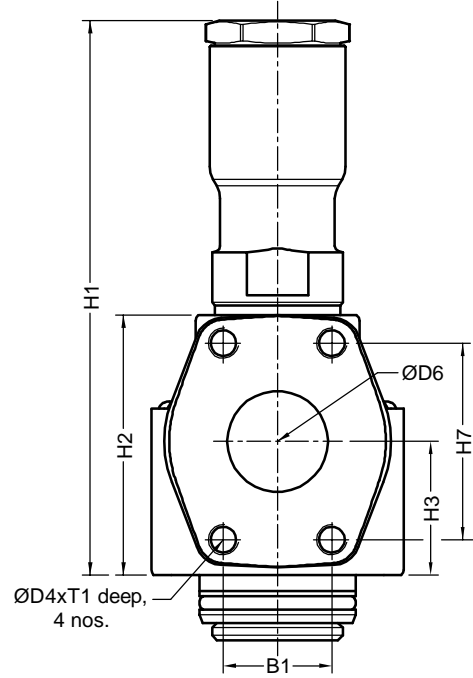

Size	B1	B2	ØD1	ØD2	ØD3	ØD4	ØD5	ØD6	ØD7	H1	H2	H3	H4	H5	H6	H7	L1	L2	L3	T1	Mass (kg)
32	58.7	80	47	25	G3/8	M10	39	32	11	176	75	40	20	8	22.5	30.2	58	55	40	15	3.5
40	43	100	54	30	G1/2	M12	52	40	18	220	103	53	26	10	30	78	75	65	50	20	6.1
50	51	120	60	30	G1/2	M12	67	50	22	250	113	58	32	12	37	89	90	75	60	20	8.9
63	62	145	80	30	G1/2	M16	82	63	26	315	139	71.5	34	15	40	106.5	105	90	72.5	25	17.4
80	62	180	92	36	G3/4	M16	102	80	33	397	160	77.5	36	20	43	106.5	130	102	90	25	28.7



Mounting Cavity Details

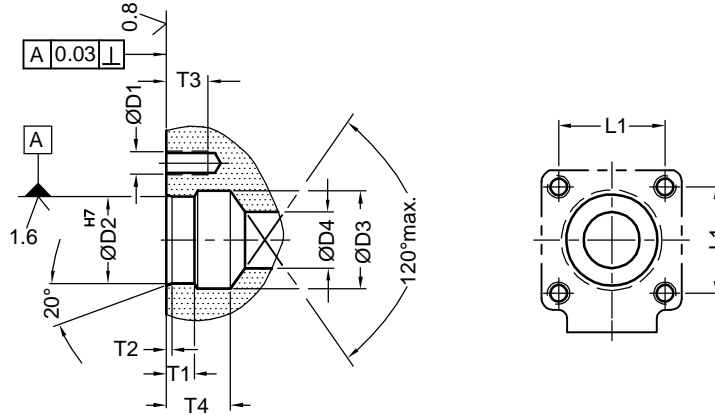

Size	ØD1	ØD2 H7	ØD3	ØD4 min.	L1	T1	T2	T3	T4 min.	Valve Fixing S.H.C. Screw	Tightening Torque (Nm)
32	M10	52	52	32	58	--	3	18	36	M10 x 80 L, 4 nos.	77
40	M16	62	66	40	75	20	4	27	46	M16 x 90 L, 4 nos.	215
50	M20	80	84	50	90	25	5	32	57	M20 x 110 L, 4 nos.	450
63	M24	95	104	63	105	25	5	46	64	M24 x 130 L, 4 nos.	1110
80	M30	115	130	80	130	30	5	50	76	M30 x 150 L, 4 nos.	2250

Technical specifications

- Construction Poppet type, Pilot operated.
- Mounting Inside oil tank mouting or flanged A port, as per ISO 6162
Special machined cavity for port B.
- Mounting position Optional
- Flow direction Free flow from port A to port B.
Piloted flow from port B to port A
- Maximum operating pressure..... At port A 16 bar
At port B and port X 315 bar
- Cracking pressure..... 0.2 bar
- Pilot pressure required to have flow.....
from port B to port A. $P_x > 2 \times P_b - P_a + 8$ bar (to open main poppet of the valve)
 $P_x > P_b / 5 - (1.2 \times P_a) + 8$ bar (to open decompression poppet of the valve)
Where P_x = Pilot pressure at port X (bar)
 P_a = Pressure at port A (bar)
 P_b = Pressure at port B (bar)

Pilot Volume.....

Size	32	40	50	63	80
cm ³	5.3	10.9	21.3	39	77.6

Flow handling Capacity (Nominal) l/min.....

Size	At an average velocity of oil through the valve (m/sec)							
	0.5	1	1.5	2	2.5	3	3.5	4
	L / min.							
32	24	48	72	96	120	144	178	216
40	38	76	114	152	190	228	260	304
50	59	118	177	236	295	354	413	472
63	93	186	279	372	465	508	651	744
80	152	304	456	608	760	912	1064	1216

- Oil velocity during pre-filling (Suction)..... Refer figure below
- Hydraulic medium Mineral oil.
- Viscosity range 10 cSt to 380 cSt
- Fluid temperature range -20°C to +80°C
- Fluid cleanliness requirement ISO 4406 20/18/15 or better.
- Mass Refer table on page 2.



Oil velocity during prefilling (suction) for different arrangements

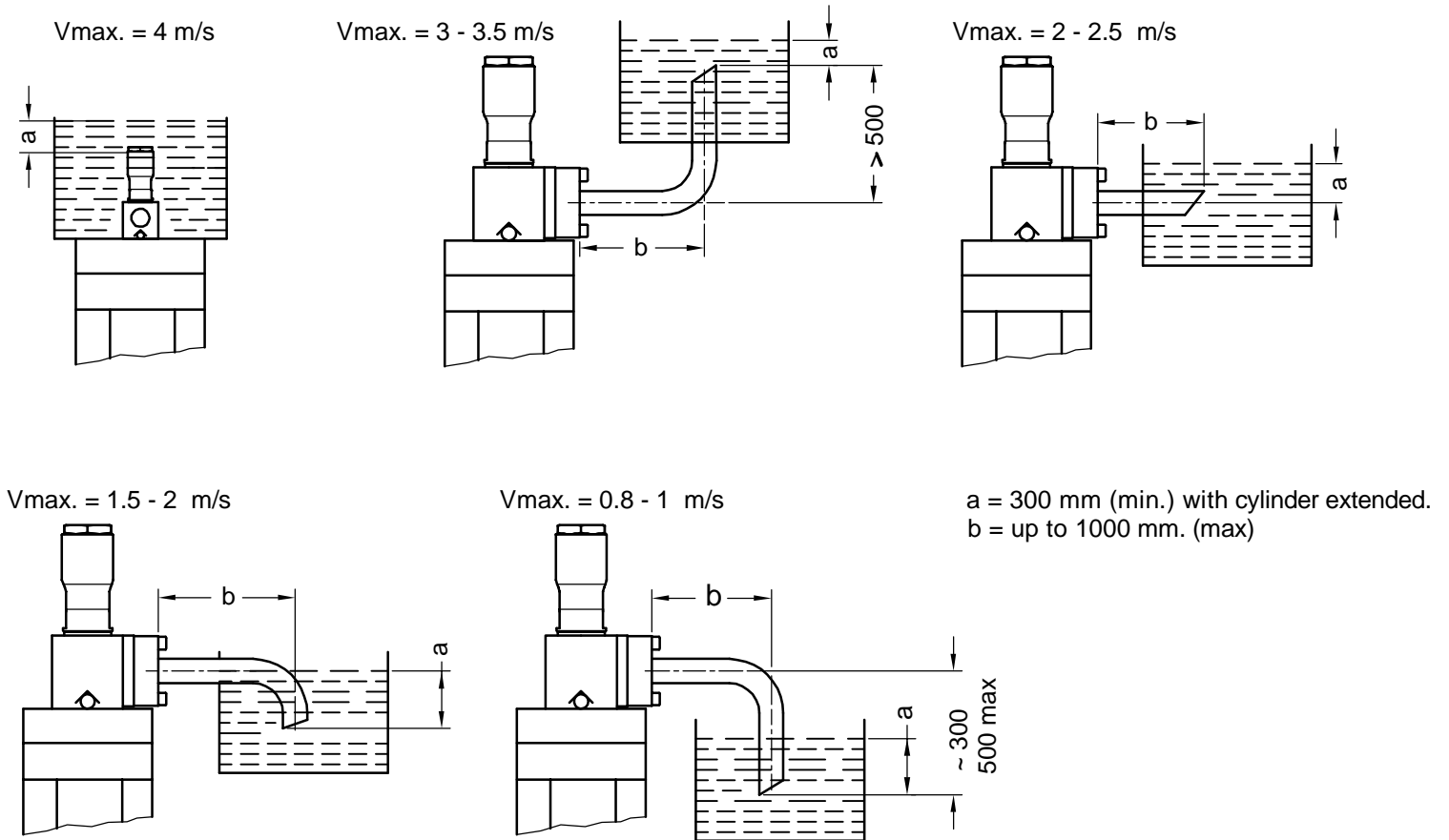

Ordering code

