

A 15i

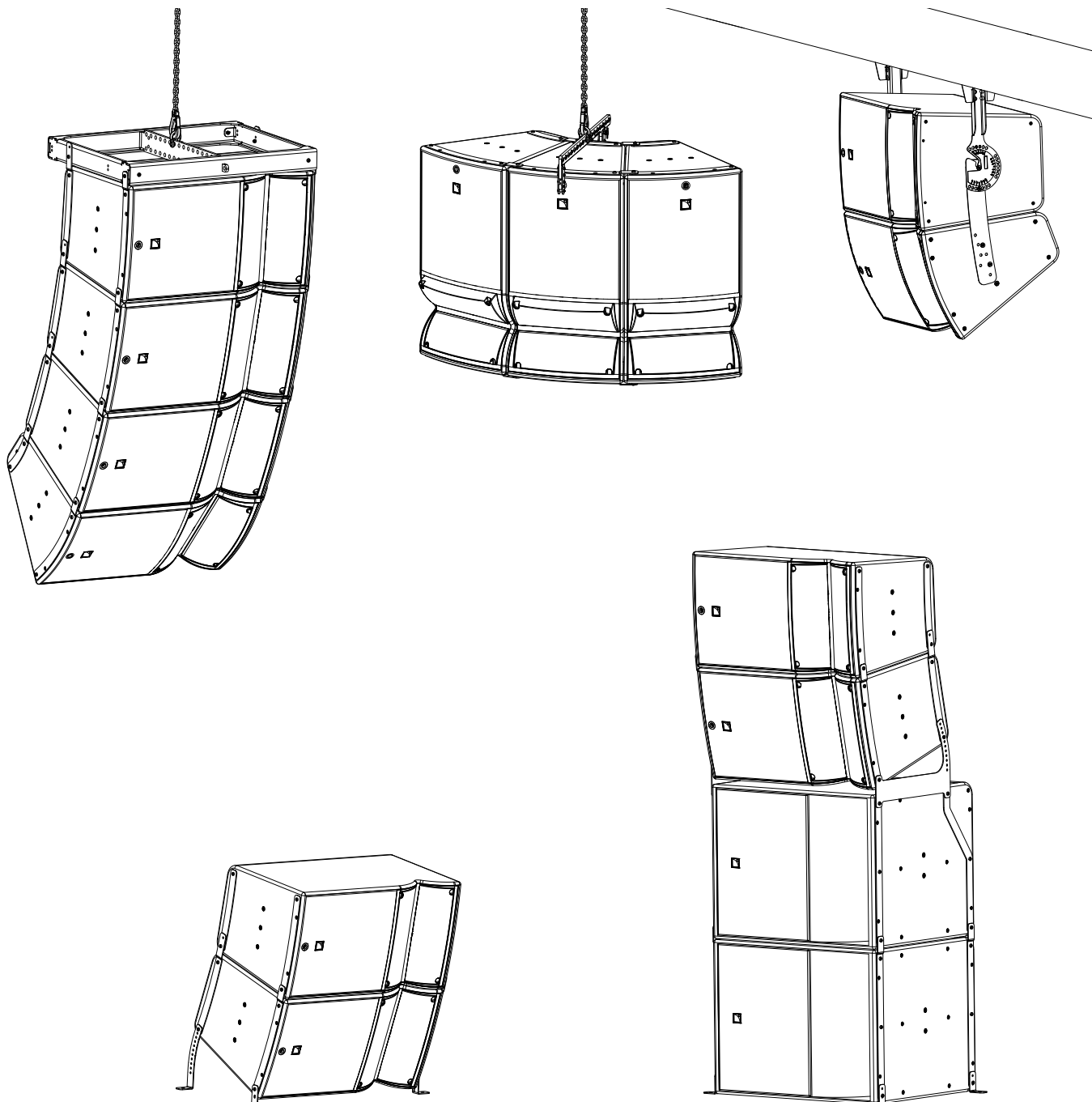

owner's manual (EN)



Document reference: A15i owner's manual (EN) version 2.1

Distribution date: May 25, 2021

© 2021 L-Acoustics. All rights reserved.

No part of this publication may be reproduced or transmitted in any form or by any means without the express written consent of the publisher.







Contents

Safety.....	5
Instructions.....	5
Introduction.....	7
A15i family.....	7
How to use this manual.....	8
System components.....	9
Loudspeaker cables.....	10
Rigging elements.....	11
Rigging plates.....	12
Electro-acoustical description.....	14
Adjustable fins.....	14
Directivity.....	17
Symmetrical configurations.....	20
Preset description.....	21
Connectors.....	22
Rigging system description.....	23
A15i system rigging.....	23
Enclosures.....	24
A15i Wide/Focus.....	24
KS21i.....	26
Rigging elements for flown arrays.....	28
A15i-BUMP.....	28
M-BARi.....	29
A15i-RIGBAR.....	30
A15i-LIFT.....	32
Rigging elements for other configurations.....	35
A-U15i.....	35
Ai-FIXBRACKET / A15i-TILTBRACKET.....	37
A15i-TILT.....	39
Front screens.....	40
Mechanical safety.....	43
Loudspeaker configurations.....	46
A15i Wide/Focus line source.....	46
With low-frequency element.....	47

A15i Wide/Focus line source element.....	48
With low-frequency element.....	48
Inspection and preventive maintenance.....	50
How to do preventive maintenance.....	50
Rigging part inspection.....	51
Mechanical system overview.....	51
Acoustical check.....	55
Rigging procedures.....	59
General principles.....	59
Tools.....	62
Flying.....	63
Flying a vertical array with A15i-BUMP.....	63
Flying a vertical array with A15i-RIGBAR.....	75
Adding a pullback with A15i-RIGBAR.....	77
Flying a radial array with A15i-LIFT.....	79
Wall-mounting or ceiling-mounting.....	84
Mounting an assembly with A-U15i.....	84
Mounting an assembly on a ceiling with A15i-TILTBRACKET.....	90
Stacking.....	95
Stacking A15i Wide/Focus on KS21i with A15i-TILT.....	95
Stacking A15i Wide/Focus with A15i-TILTBRACKET.....	101
Securing a screen.....	104
Connection to LA amplified controllers.....	107
Cabling schemes.....	107
Cabling.....	109
Corrective maintenance.....	113
A15i Focus.....	113
A15i Wide.....	121
KS21i.....	129
Specifications.....	134
APPENDIX A: Authorized configurations with A15i-LIFT.....	151
APPENDIX B: Configurations with A-U15i.....	153
APPENDIX C: Recommendation for speaker cables.....	156
APPENDIX D: Specifications for custom rigging systems.....	157

Safety

Instructions

-  **Inspect the system before any deployment.**
Perform safety related checks and inspections before any deployment.
- Perform preventive maintenance at least once a year.**
Refer to the preventive maintenance section for a list of actions and their periodicity.
Insufficient upkeep of the product can void the warranty.
- If any safety issue is detected during inspection, do not use the product before performing corrective maintenance.**
Check for issues. A rigging system part or fastener is missing or loose. A rigging system part exhibits: bends, breaks, broken parts, corrosion, cracks, cracks in welded joints, deformation, denting, wear, holes. A safety cue or label is missing.
-  **Never incorporate equipment or accessories not approved by L-Acoustics.**
-  **Read all the related PRODUCT INFORMATION documents shipped with the products before exploiting the system.**
-  **Do not store the product on an unstable cart, stand, tripod, bracket, or table.**
-  **Beware of sound levels.**
Do not stay within close proximity of loudspeakers in operation.
Loudspeaker systems are capable of producing very high sound pressure levels (SPL) which can instantaneously lead to permanent hearing damage to performers, production crew and audience members. Hearing damage can also occur at moderate level with prolonged exposure to sound.
Check the applicable laws and regulations relating to maximum sound levels and exposure times.
-  **Work with qualified personnel for rigging the system**
Installation should only be carried out by qualified personnel that are familiar with the rigging techniques and safety recommendations outlined in this manual.
- Ensure personnel health and safety**
During installation and set-up personnel must wear protective headgear and footwear at all times. Under no circumstances is personnel allowed to climb on a loudspeaker assembly.
- Respect the Working Load Limit (WLL) of third party equipment.**
L-Acoustics is not responsible for any rigging equipment and accessories provided by third party manufacturers. Verify that the Working Load Limit (WLL) of the suspension points, chain hoists and all additional hardware rigging accessories is respected.
- Respect the maximum configurations and the recommended safety precautions.**
For safety issue, respect the maximum configurations outlined in this manual. To check the conformity of any configuration in regards with the safety precautions recommended by L-Acoustics, model the system in Soundvision and refer to the warnings in Mechanical Data section.
- Be cautious when flying a loudspeaker configuration.**
Before installing/raising the product, check each individual element to make sure that it is securely fastened to the adjacent element. Always verify that no one is standing underneath the product when it is being installed/raised. Never leave the product unattended during the installation process.
As a general rule, L-Acoustics recommends the use of secondary safety at all times.
- Be cautious when ground-stacking a loudspeaker array.**
Do not stack the loudspeaker array on unstable ground or surface. If the array is stacked on a structure, platform, or stage, always check that the latter can support the total weight of the array.
As a general rule, L-Acoustics recommends the use of safety straps at all times.

Risk of falling objects

Verify that no unattached items remain on the product or assembly.

Risk of tipping

Remove all rigging accessories before transporting a product or an assembly.

Take into account the wind effects on dynamic load.

When a loudspeaker assembly is deployed in an open air environment, wind can produce dynamic stress to the rigging components and suspension points.

If the wind force exceeds 6 bft (Beaufort scale), lower down and/or secure the product or the assembly.

**Intended use**

This system is intended for use by trained personnel for professional applications.



As part of a continuous evolution of techniques and standards, L-Acoustics reserves the right to change the specifications of its products and the content of its documents without prior notice.

Check www.l-acoustics.com on a regular basis to download the latest document and software updates.

**Long term exposure to extreme conditions may damage the product.**

For more information, refer to the **Products weather protection** document, available on the website.

**Read the maintenance section of this document before servicing the product.****Contact L-Acoustics for advanced maintenance.**

Any unauthorized maintenance operation will void the product warranty.



This marking indicates that this product should not be disposed of with other household waste throughout the EU. To prevent possible harm to the environment or human health from uncontrolled waste disposal, recycle it responsibly to promote the sustainable reuse of material resources. To return your used device, please use the return and collection systems or contact the retailer where the product was purchased. They can take this product for environmentally safe recycling.



Introduction

A15i family

Part of the A Series, A15i is a medium throw product line designed for installation applications up to 45 m. The highly multifunctional family includes A15i Focus and A15i Wide, passive 15" systems with distinct coverage patterns. A15i products can be flown or stacked in combinations to form vertical or horizontal line sources or used individually as configurable directivity point sources.

A15i can adapt to virtually any audience geometry with two enclosure coverage options (10° or 30°), Panflex for user adjustable waveguide directivity (70°, 110° or 90° asymmetrical) and a range of accessories for vertical or horizontal deployment.

A15i deployment requires a single preset that is optimized to provide amazing plug-and-play performance for both A15i models regardless of Panflex configuration. Performance can be further enhanced with L-Acoustics software optimization tools.

A15i provides the low frequency contour of a large concert system. The dedicated KS21i subwoofer can be groundstacked or flown with A15i products to reinforce contour and extend bandwidth to 29 Hz.

The discreet yet powerful A15i is an ideal solution for integration applications that require aesthetics and concert level performance for venues large and small.

How to use this manual

The A15i owner's manual is intended for all actors involved in the system design, implementation, preventive and corrective maintenance of the A15i system. It must be used as follows:

1. Read the technical description for an overview of all system elements, their features, and their compatibilities.
 - [Electro-acoustical description](#) (p.14)
 - [Rigging system description](#) (p.23)
2. Prepare the system configuration. Consider the mechanical limits and the available acoustical configurations.
 - [Mechanical safety](#) (p.43)
 - [Loudspeaker configurations](#) (p.46)
3. Before rigging the system, perform mandatory inspections and functional checks.
 - [Inspection and preventive maintenance](#) (p.50)
4. To deploy the system, follow the step-by-step rigging instructions and refer to the cabling schemes.
 - [Rigging procedures](#) (p.59)
 - [Connection to LA amplified controllers](#) (p.107)



The [Corrective maintenance](#) (p.113) section contains the operations authorized for the end user.

Performing another operation exposes to hazardous situations.

For advanced maintenance, contact your L-Acoustics representative.

As part of a continuous evolution of techniques and standards, L-Acoustics reserves the right to change the specifications of its products and the content of its document without prior notice. Please check www.l-acoustics.com on a regular basis to download the latest document and software updates.

Contact information

For information on advanced corrective maintenance:

- contact your Certified Provider or your L-Acoustics representative
- for Certified Providers, contact the L-Acoustics customer service: customer.service@l-acoustics.com

Symbols

The following symbols are used in this document:



This symbol indicates a potential risk of harm to an individual or damage to the product.

It can also notify the user about instructions that must be strictly followed to ensure safe installation or operation of the product.



This symbol notifies the user about instructions that must be strictly followed to ensure proper installation or operation of the product.



This symbol notifies the user about complementary information or optional instructions.

System components

Loudspeaker enclosures

A15i Focus	2-way passive constant curvature WST® 10° enclosure: 15" LF + 3" HF diaphragm (installation version)
A15i Wide	2-way passive constant curvature WST® 30° enclosure: 15" LF + 3" HF diaphragm (installation version)
KS21i	High power compact subwoofer: 1 x 21" (installation version)

Powering and driving system

LA2Xi / LA4X / LA8 / LA12X Amplified controller with DSP, preset library and networking capabilities

 Refer to the LA2Xi / LA4X / LA8 / LA12X owner's manual for operating instructions.

Cables

speaker cable	2.5 mm ² cable Speaker cable used to connect enclosures in parallel. Adapt the cable length to the installation.
custom 2-point speakON cable	2-point speakON cable (2.5 mm ² gauge) to bare wire cable This cable needs to be custom made.

 **Information about the connection of the enclosures to the LA amplified controllers is given in this document.**

Refer to the LA2Xi / LA4X / LA8 / LA12X owner's manual for detailed instructions about the whole cabling scheme, including modulation cables and network.

Rigging elements

Ai-FIXBRACKET	Fastening bracket for A15i, A10i and KS21i
A15i-TILTBRACKET	Fastening bracket with angles for A15i
A15i-TILT	Rigging element with angles for A15i above or under KS21i
KS21i-LINK	Rigging plates for KS21i
KS21i-ENDLINK	End rigging plates for KS21i
KS21i-SLINK	Rear rigging plates for A15i and A10i onto or under KS21i
KS21i-ENDSLINK	End rear rigging plates for A15i and A10i onto or under KS21i
A15iFOCUS-LINK	Rigging plates for A15i Focus
A15iWIDE-LINK	Rigging plates for A15i Wide
A15iWIDE-ENDLINK	End rigging plates for A15i Wide
A15iFOCUS-ENDLINK	End rigging plates for A15i Focus
A15i-ULINK	Rigging plates for flying two A15i with A-U15i
A15iKS21i-ULINK	Rigging plates for flying A15i under KS21i with A-U15i
KS21i-ULINK	Rigging plates for flying two KS21i with A-U15i
A15i-BUMP	Flying frame for vertical deployment of A15i and KS21i
A15i-LIFT	Rigging element for horizontal deployment of A15i
A15i-RIGBAR	Rigging bar and pullback for A15i and KS21i

A-U15i	U-bracket for A15i and KS21i
CLAMP250	Clamp certified for 250 kg
M-BARi	Extension bar for rigging frame (installation version)

Transportation accessories

A15iFOCUS-SCREEN	Acoustically transparent front screen for A15i Focus
A15iWIDE-SCREEN	Acoustically transparent front screen for A15i Wide
A15iFOCUS-SCREEN-LIFT	Acoustically transparent front screen for A15i Focus with A15i-LIFT
A15iWIDE-SCREEN-LIFT	Acoustically transparent front screen for A15i Wide with A15i-LIFT
KS21i-SCREEN	Acoustically transparent front screen for KS21i

Software applications

Soundvision	3D acoustical and mechanical modeling software
LA Network Manager	Software for remote control and monitoring of amplified controllers



Refer to the **Soundvision** help.
Refer to the **LA Network Manager** help.

Loudspeaker cables



2.5 mm² cable

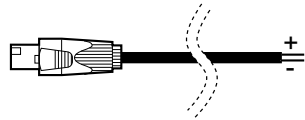

2-point speakON cable (2.5 mm² gauge) to bare wire cable

This cable needs to be custom made.

Rigging elements

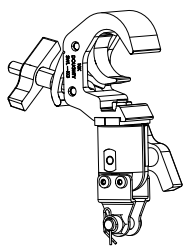

CLAMP250

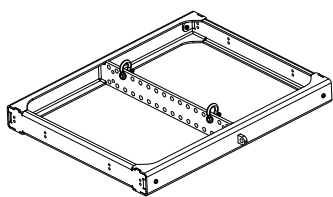

A15i-BUMP

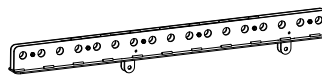

M-BARi

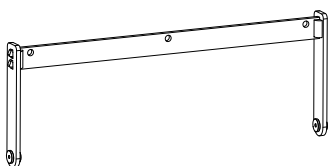

A15i-RIGBAR

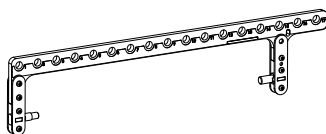

A15i-LIFT

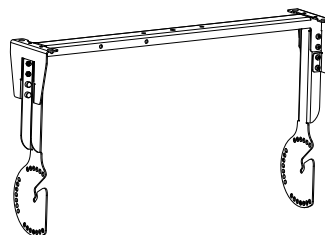

A-U15i

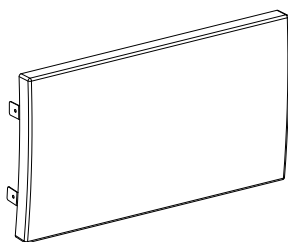

A15iFOCUS-SCREEN

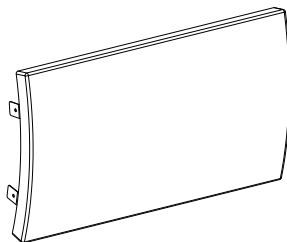

A15iWIDE-SCREEN

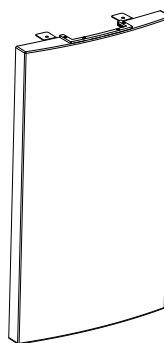

A15iFOCUS-SCREEN-LIFT

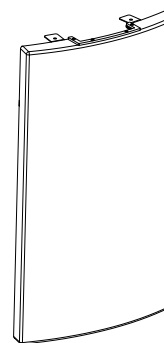

A15iWIDE-SCREEN-LIFT

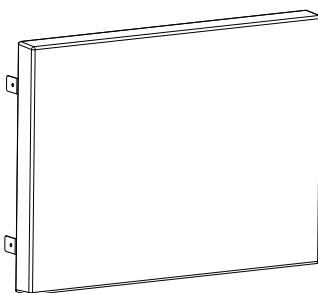

KS21i-SCREEN

Rigging plates

On enclosure

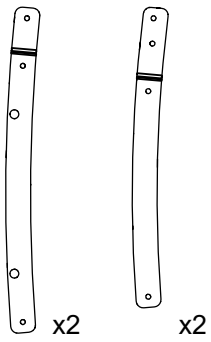

A15iFOCUS-LINK
Rigging plates
for A15i Focus

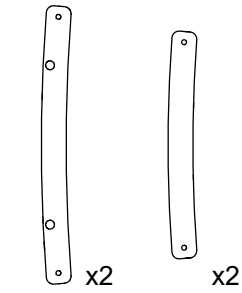

A15iFOCUS-ENDLINK
End rigging plates
for A15i Focus

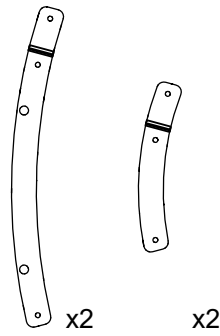

A15iWIDE-LINK
Rigging plates
for A15i Wide

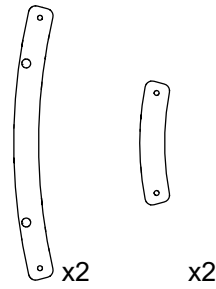

A15iWIDE-ENDLINK
End rigging plates
for A15i Wide

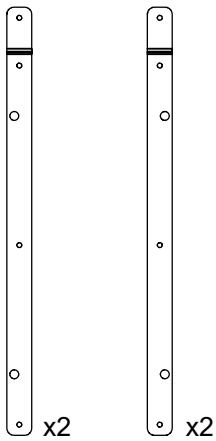

KS21i-LINK
Rigging plates
for KS21i

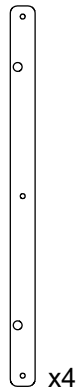

KS21i-
ENDLINK
End rigging
plates for
KS21i

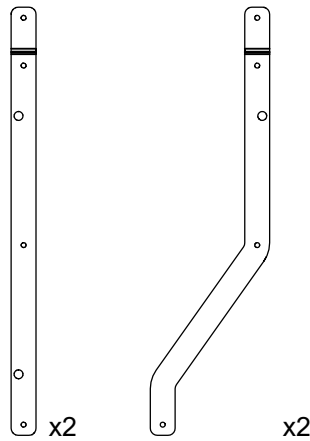

KS21i-SLINK
Rigging plates for
A15i under KS21i

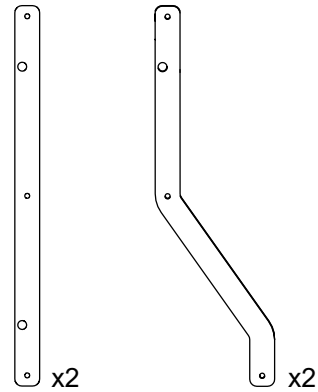

KS21i-ENDSLINK
End rigging plates for
A15i under KS21i



Ai-
FIXBRACKET
Fastening
brackets for
A15i, A10i
and KS21i

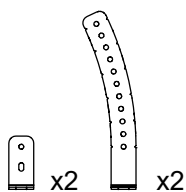

A15i-TILTBRACKET
Fastening brackets
with angles for A15i

Inter-enclosure

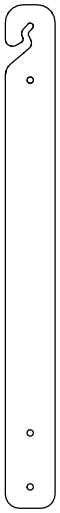

x2

KS21i-ULINK
Rigging plates for flying two KS21i with A-U15i



x2

A15iKS21i-ULINK
Rigging plates for flying A15i under KS21i with A-U15i

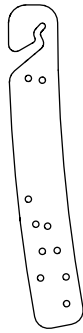

x2

A15i-ULINK
Rigging plates for flying two A15i with A-U15i

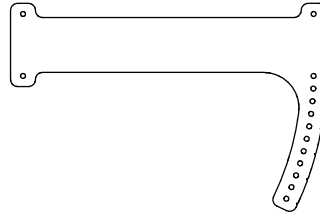

x2

A15i-TILT
Rigging elements with angles for A15i above or under KS21i

Electro-acoustical description

Adjustable fins

A15i Focus and A15i Wide feature L-Fins to adjust the waveguide directivity to one of four settings: 110° / 70° symmetric or 90° asymmetric (35°/55° or 55°/35°).

The same [A15] preset drives all directivity settings of both enclosures.

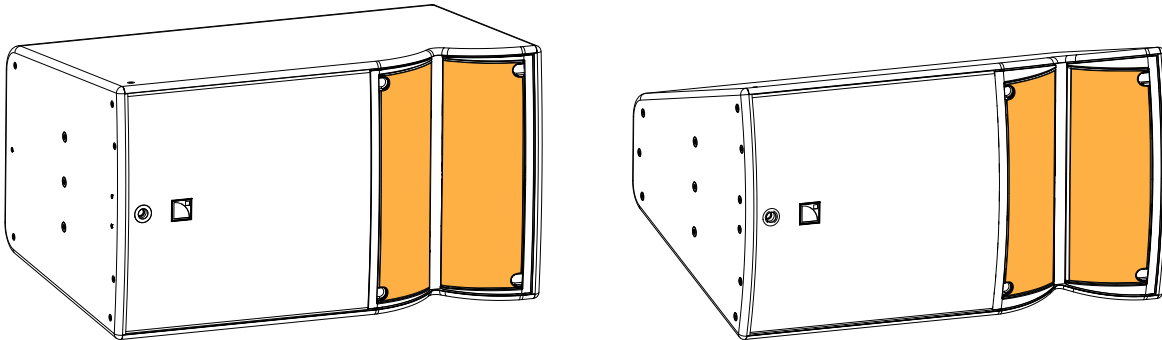

Within a line source, combine A15i Focus and A15i Wide with custom directivity settings to improve SPL mapping and throw capability.

110° setting

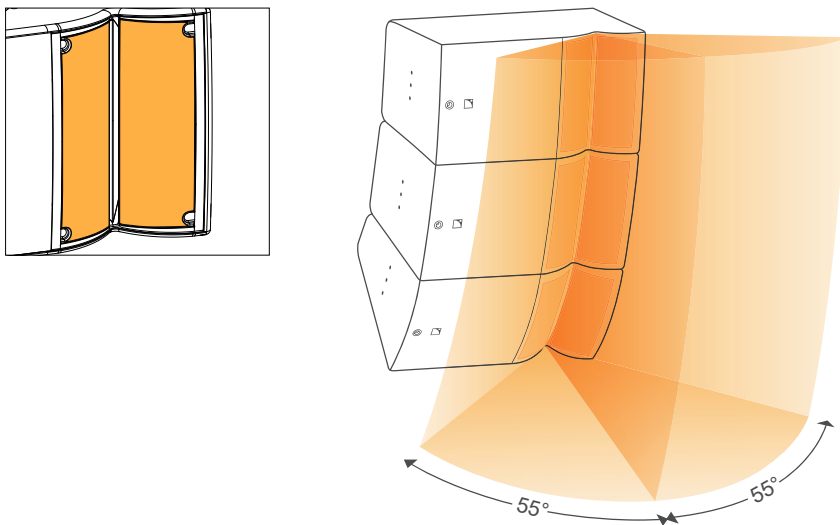

70° setting

Setting the fins in the 35° position offers an additional 2 dB on-axis (> 2 kHz).

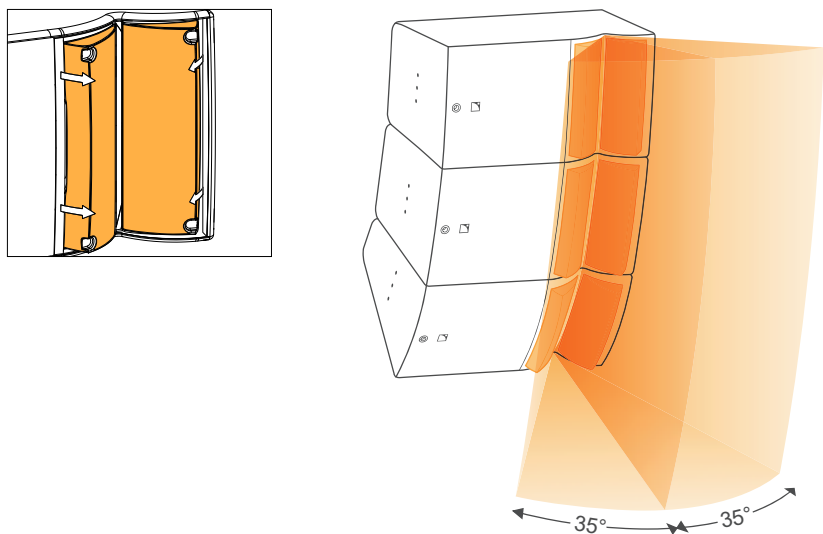

90° settings

Setting the fins in the 90° position offers an additional 1 dB on-axis (> 2 kHz).

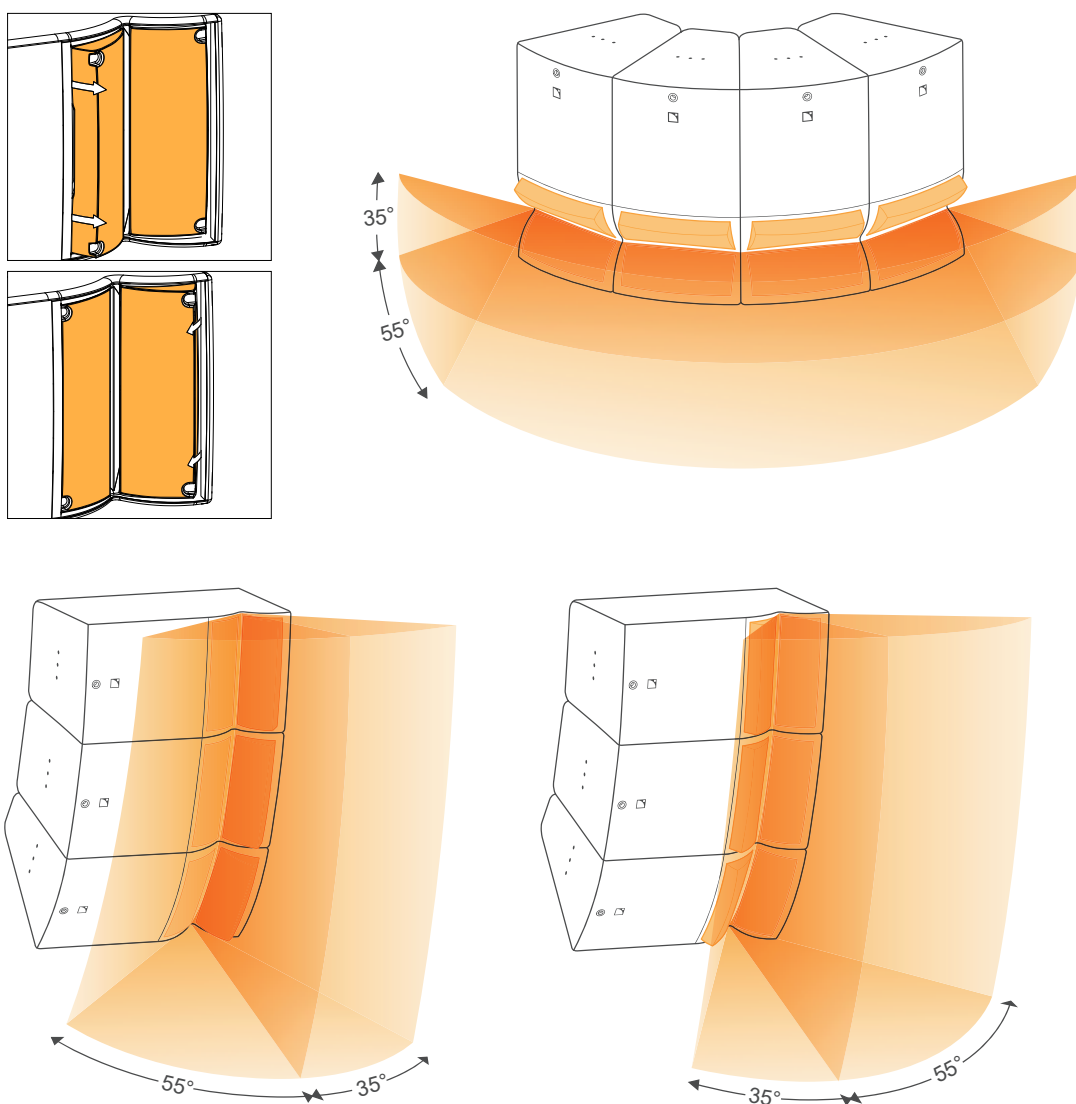

Mixed settings

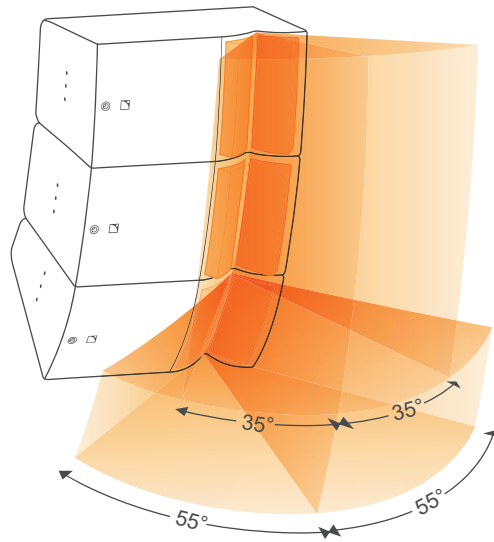

Directivity

A15i Focus

A15i Focus generates an enclosure directivity pattern of 10° and a waveguide directivity pattern of $70^\circ / 110^\circ$ symmetric or 90° asymmetric (-6 dB) depending on the fins settings.

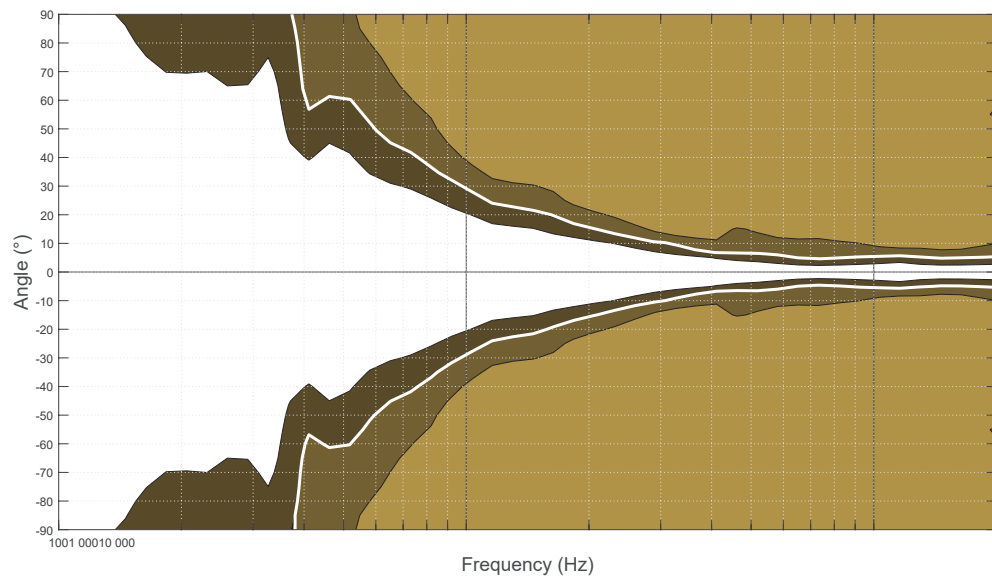
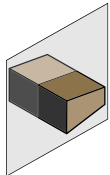

Dispersion angle diagram of one upright A15i Focus, using lines of equal sound pressure at -3 dB, -6 dB, -12 dB.

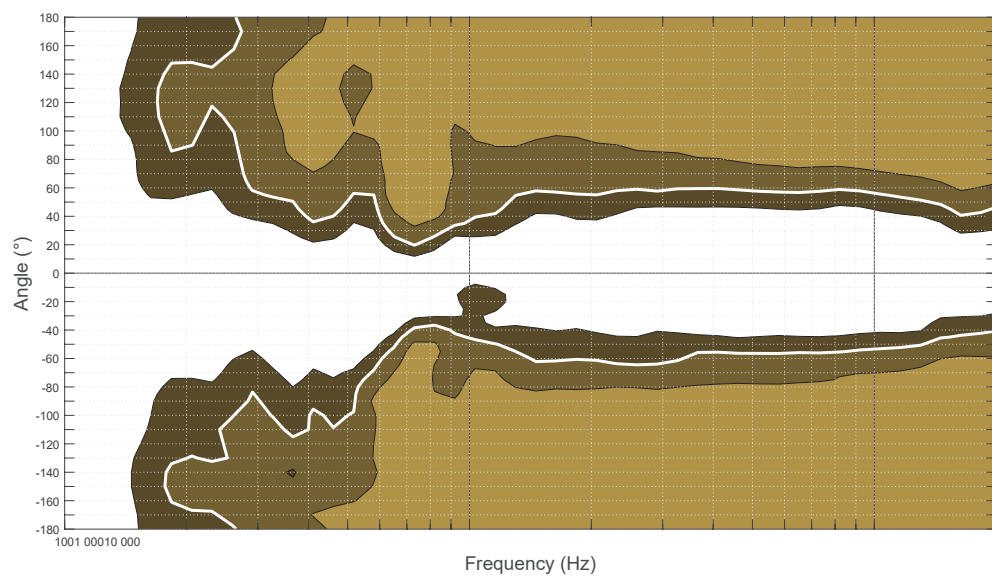
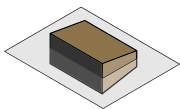

Dispersion angle diagram of one A15i Focus with 110° fins setting, using lines of equal sound pressure at -3 dB, -6 dB, -12 dB.

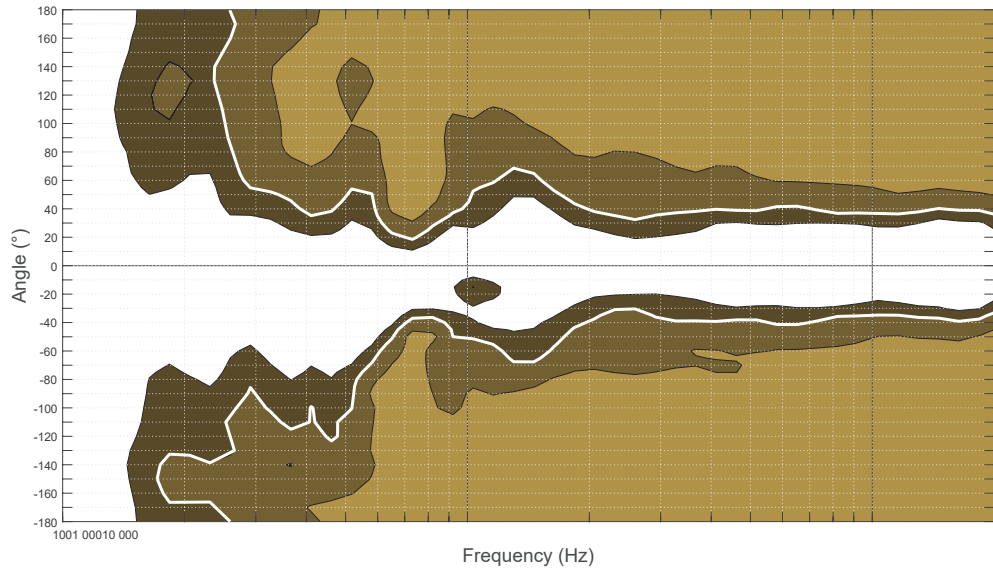
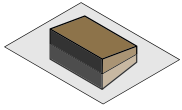

Dispersion angle diagram of one A15i Focus with 70° fins setting, using lines of equal sound pressure at -3 dB, -6 dB, -12 dB.

A15i Wide

A15i Wide generates an enclosure directivity pattern of 30° and a waveguide directivity pattern of 70° / 110° symmetric or 90° asymmetric (-6 dB) depending on the fins settings.

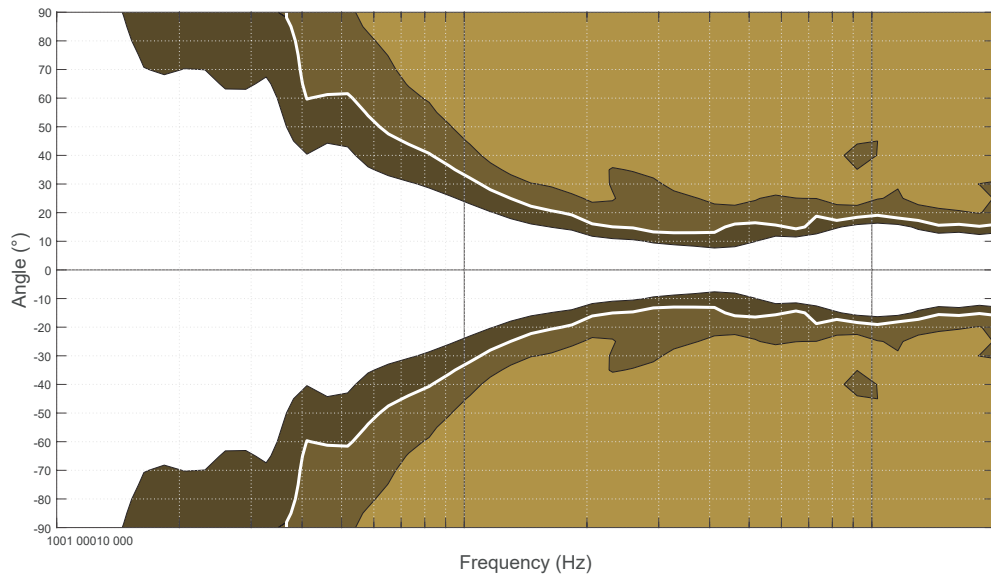
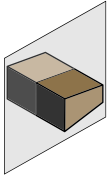

Dispersion angle diagram of one upright A15i Wide, using lines of equal sound pressure at -3 dB, -6 dB, -12 dB.

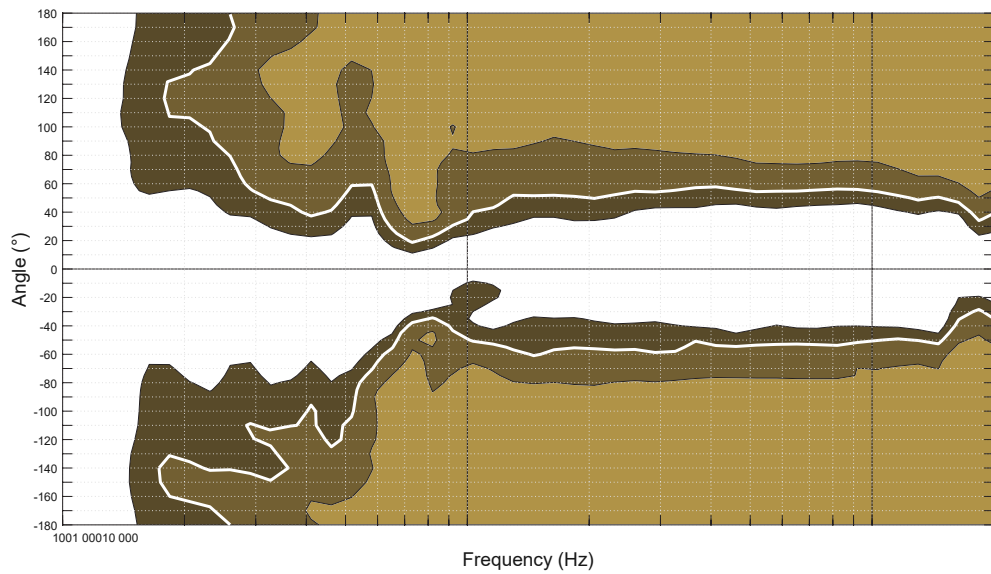
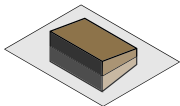

Dispersion angle diagram of one A15i Wide with 110° fins setting, using lines of equal sound pressure at -3 dB, -6 dB, -12 dB.

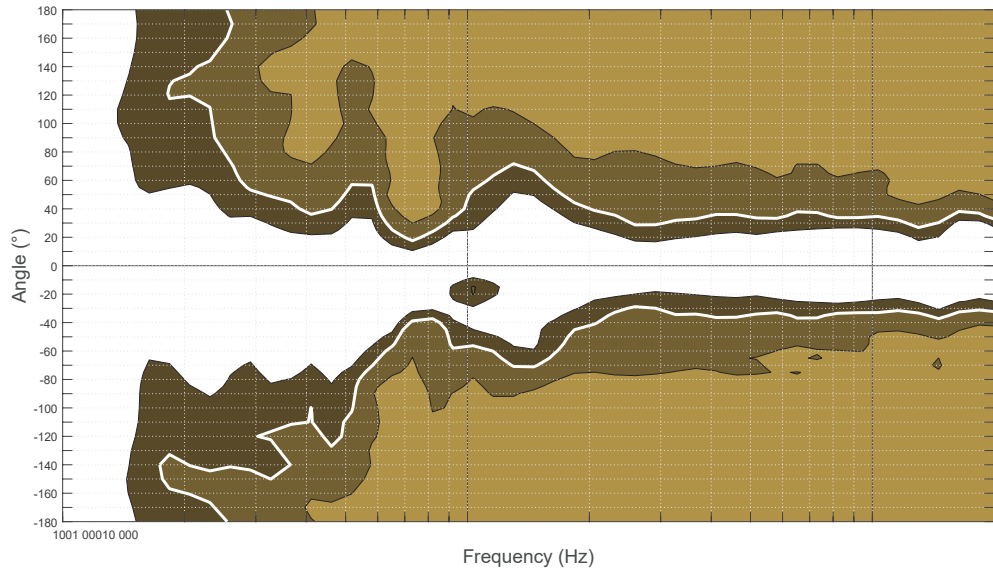
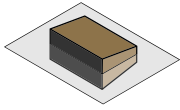

Dispersion angle diagram of one A15i Wide with 70° fins setting, using lines of equal sound pressure at -3 dB, -6 dB, -12 dB.

Symmetrical configurations

The A15i rigging system is designed to enable a completely symmetrical setup for stereo applications.

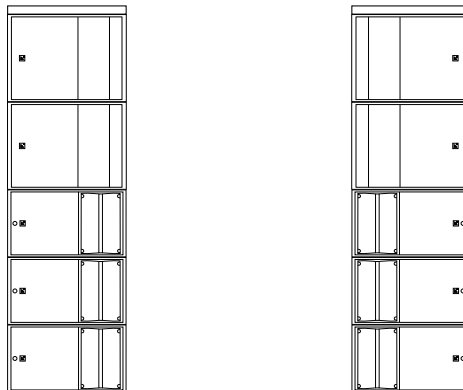

Preset description

[A15]

outputs	channels	routing	gain	delay	polarity	mute
OUT 1	PA	IN A	0 dB	0 ms	+	ON
OUT 2	PA	IN A	0 dB	0 ms	+	ON
OUT 3	PA	IN A	0 dB	0 ms	+	ON
OUT 4	PA	IN A	0 dB	0 ms	+	ON

[A15_FI]

outputs	channels	routing	gain	delay	polarity	mute
OUT 1	PA	IN A	0 dB	0 ms	+	ON
OUT 2	PA	IN A	0 dB	0 ms	+	ON
OUT 3	PA	IN B	0 dB	0 ms	+	ON
OUT 4	PA	IN B	0 dB	0 ms	+	ON

[KS21_60]

outputs	channels	routing	gain	delay	polarity	mute
OUT 1	SB	IN A	0 dB	0 ms	+	ON
OUT 2	SB	IN A	0 dB	0 ms	+	ON
OUT 3	SB	IN A	0 dB	0 ms	+	ON
OUT 4	SB	IN A	0 dB	0 ms	+	ON

[KS21_60_C] [KS21_60_Cx]

loudspeaker elements	outputs	channels	routing	gain	delay	polarity	mute
SR	OUT 1	SR	IN A	0 dB	0 ms	+	ON
SB	OUT 2	SB					ON
SB	OUT 3	SB					ON
SB	OUT 4	SB					ON

Connectors



Each set of terminal block connectors (+ and -) can be used interchangeably as IN or LINK connector.

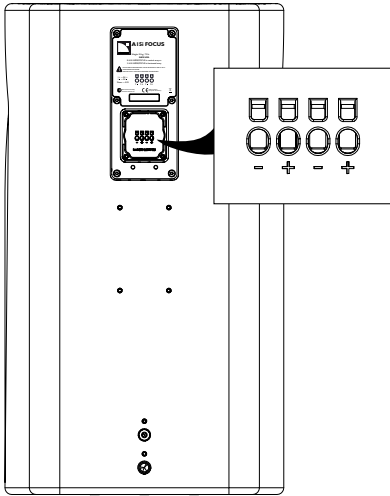

A15i Focus

1 x 4-point terminal block with push-in connection

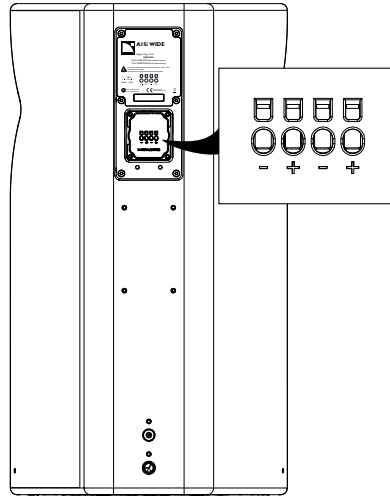

A15i Wide

1 x 4-point terminal block with push-in connection

Internal pinout for L-Acoustics 2-way passive enclosures

terminal block points	IN +	IN -
Transducer connectors	+	-

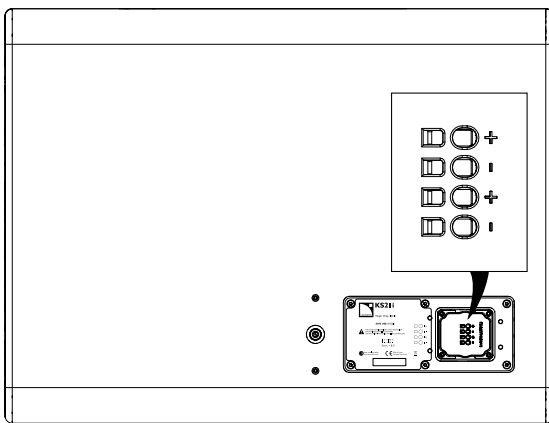

KS21i

1 x 4-point terminal block with push-in connection

Internal pinout for L-Acoustics subwoofers

terminal block points	IN +	IN -
Transducer connectors	LF +	LF -

Rigging system description

A15i system rigging

The A15i system is the installation version of the A15 system and features a simplified rigging system to optimize visual impact.

The enclosures are assembled together with rigging plates and rigging accessories suited for installation. Like the A15 system, the enclosures can be deployed in vertical or horizontal arrays. Multiple rigging kits are available depending on the desired configuration (refer to [Rigging plates](#) (p.12)).



The logo on the enclosure front can be rotated to adapt to every configuration.

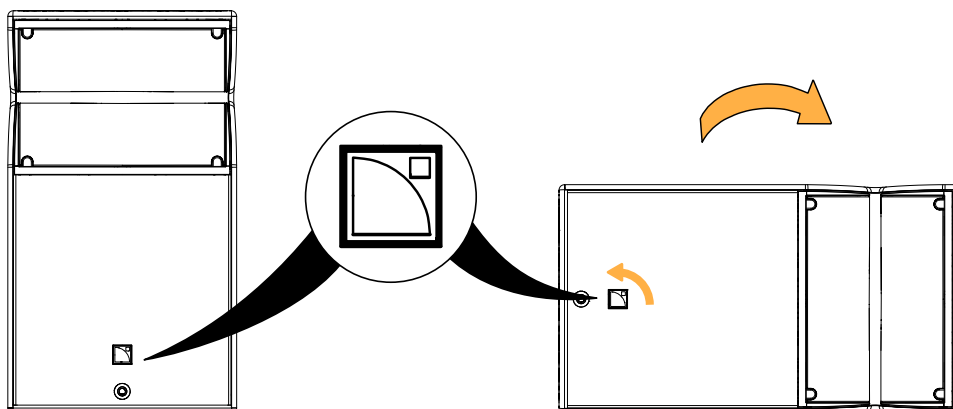

Enclosures

A15i Wide/Focus

A15i Wide/Focus is compatible with two types of rigging plate kits:

- standard rigging plates
(A15iFOCUS-LINK / A15iWIDE-LINK)
- end rigging plates
(A15iFOCUS-ENDLINK / A15iWIDE-ENDLINK)

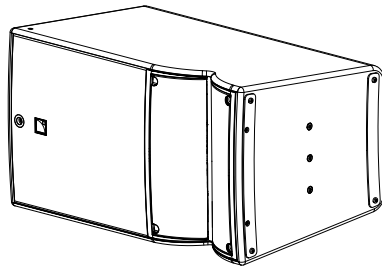
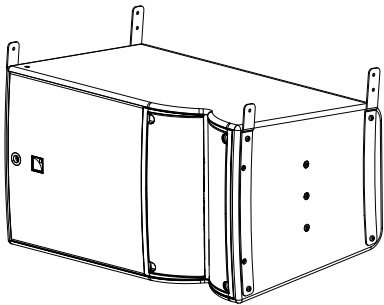

A15iFOCUS-LINK can be used to add an inter-element angle of 5° between two A15i Focus.

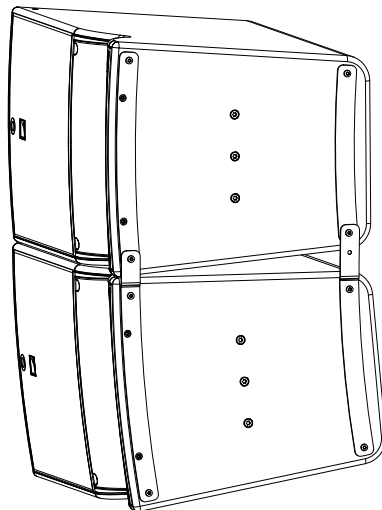

A15i Wide/Focus feature on each side:

- Four M6 inserts for flown configurations with a rigging frame or stacked configurations.
- Three M8 inserts for wall-mounting or ceiling-mounting with a bracket.
- Two M6 inserts for securing a screen.

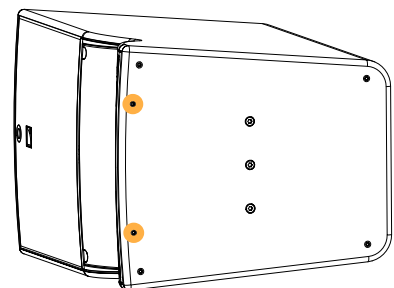
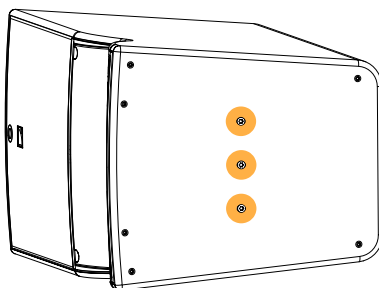
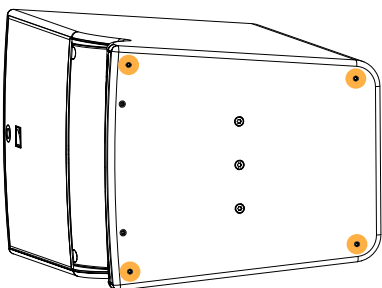

The inserts are fitted with placeholder screws.

! Rigging screws

Only use the rigging screws provided by L-Acoustics.
Do not use the placeholder screws for rigging.

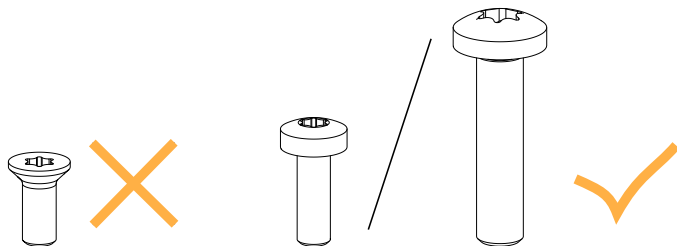

! Always put the placeholder screws back in place to avoid leaks.

A15i Wide/Focus feature two lodgings to create radial arrays with [A15i-LIFT](#) (p.32).

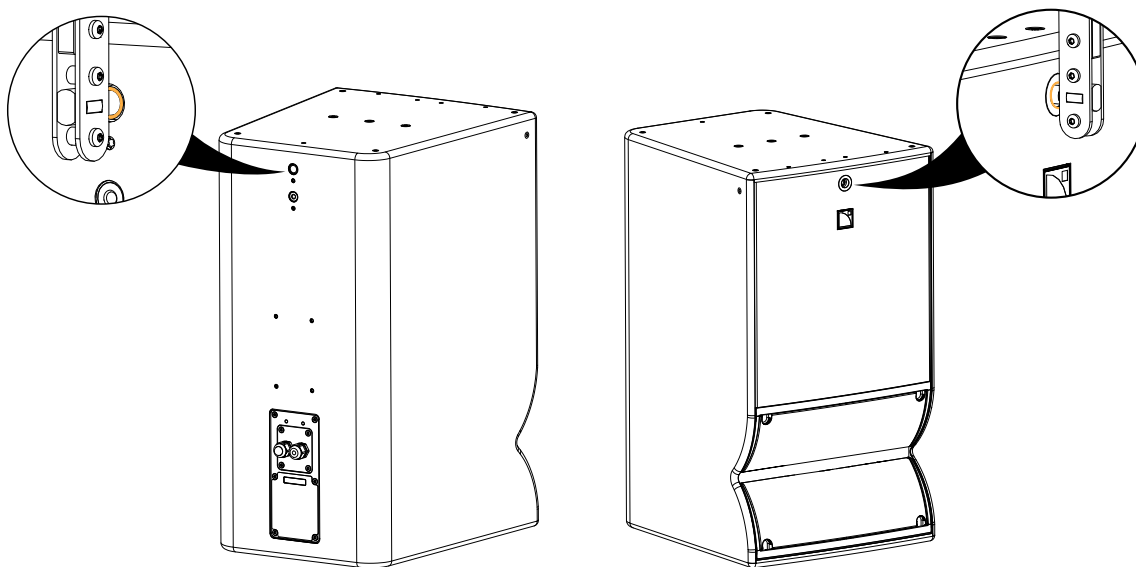

A DIN580-compatible M8 threaded insert is available to implement a secondary safety.

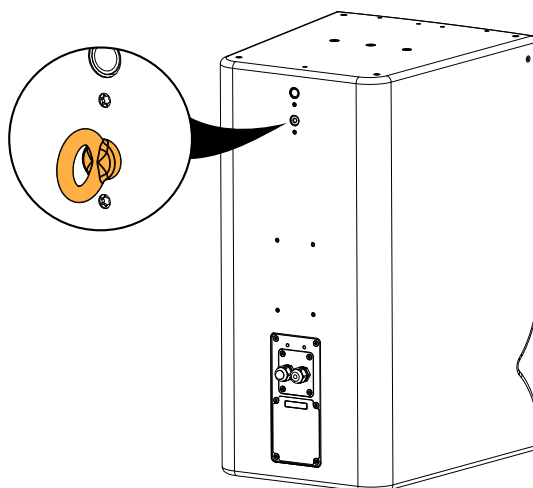

Four M6 inserts are available at the back of A15i Wide/Focus for compatible rigging accessories.

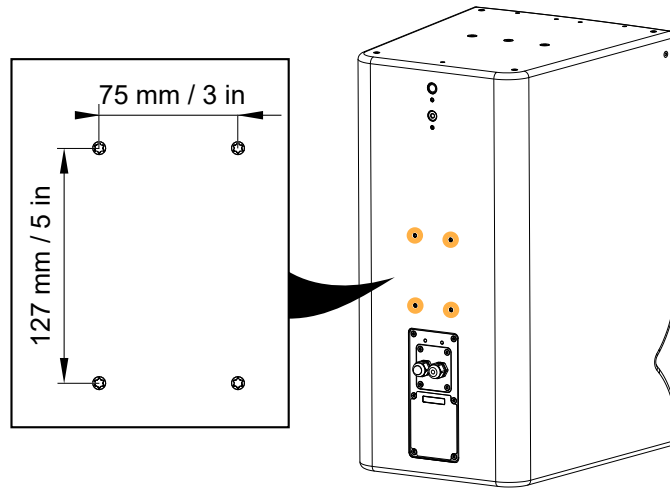

KS21i

KS21i is compatible with four types of rigging plate kits:

- standard rigging plates
(KS21i-LINK)

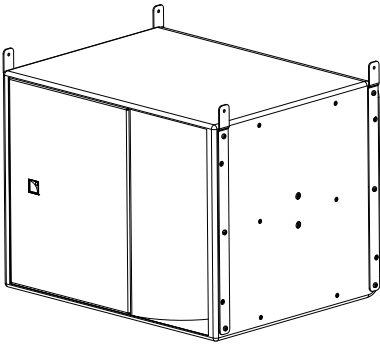

- S-shaped standard rigging plates
(KS21i-SLINK)

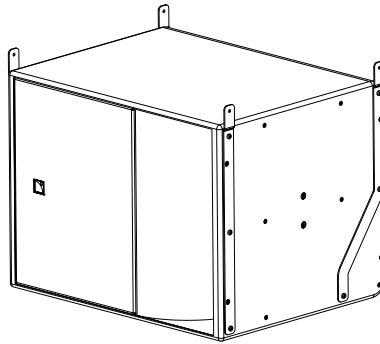

- end rigging plates
(KS21i-ENDLINK)

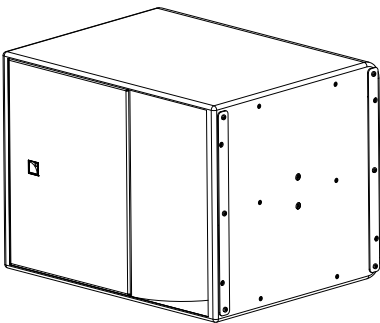

- S-shaped end rigging plates
(KS21i-ENDSLINK)

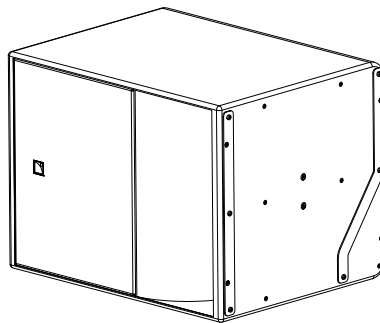

S-shaped rigging plates are used to transition from a KS21i array to a A15i Wide/Focus array.

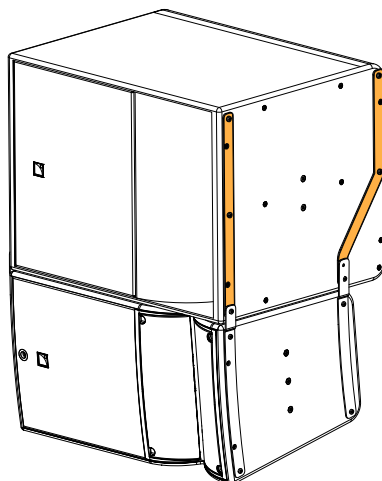

KS21i features 18 inserts on each side:

- 12 M6 inserts for flown configurations with a rigging frame.
- Two M8 inserts for wall-mounting or ceiling-mounting with a bracket.
- Four M6 inserts for securing a screen in standard or cardioid configuration.

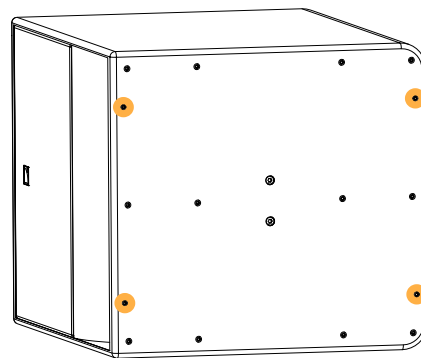
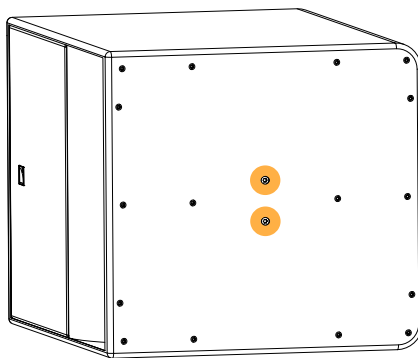
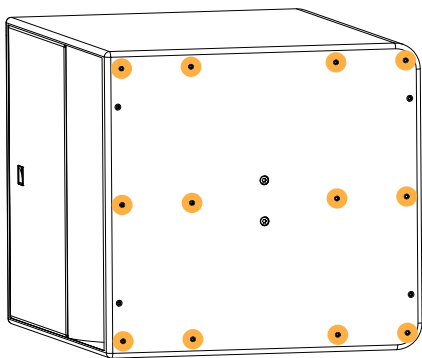

The inserts are fitted with placeholder screws.

! Rigging screws

Only use the rigging screws provided by L-Acoustics.
Do not use the placeholder screws for rigging.

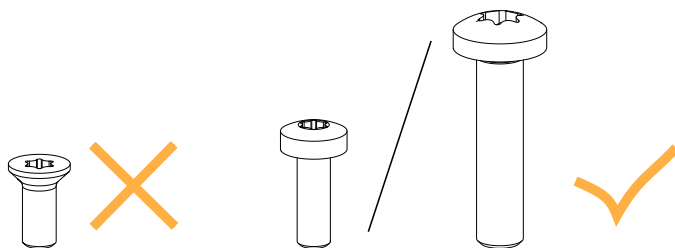

! Always put the placeholder screws back in place to avoid leaks.

Rigging elements for flown arrays

A15i-BUMP

A15i-BUMP is a reversible rigging frame for flying vertical arrays of A15i Wide/Focus or KS21i.

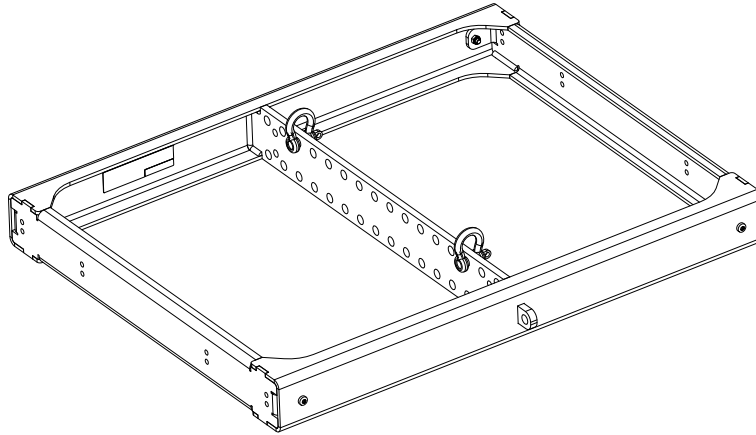

A15i-BUMP is secured to the array with four M6x18 rigging screws and M6 nuts (provided).

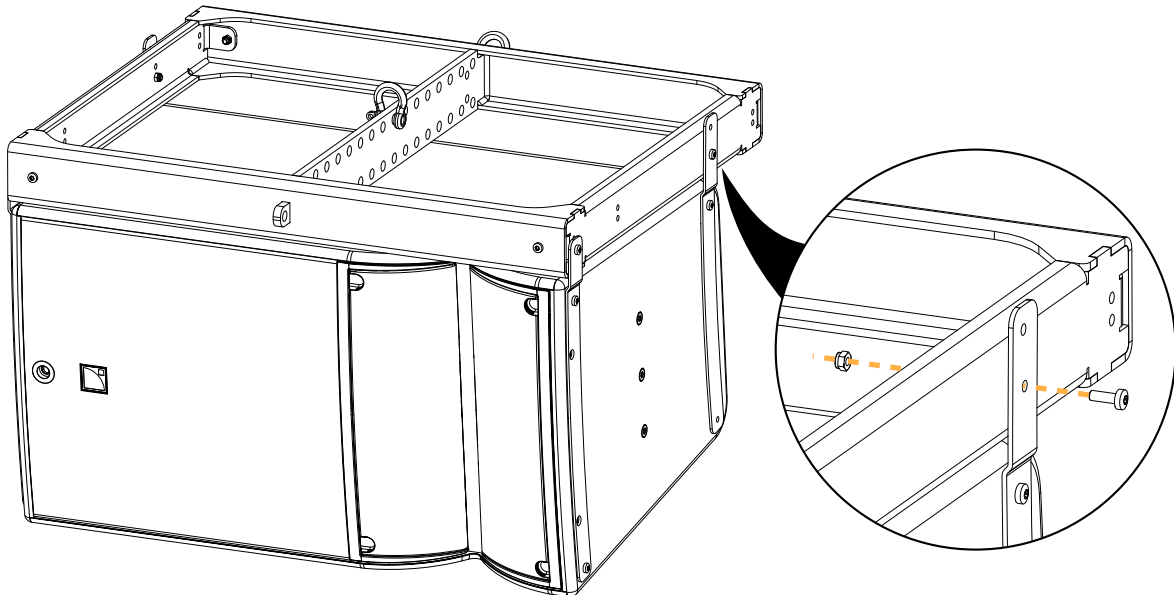

Multiple pickup points are available for site angle adjustments: 16 pickup points on each side, one front pickup point (F), and one rear pickup point (R). They are compatible with Ø12 mm shackles WLL 1 t (two provided) and CLAMP250.

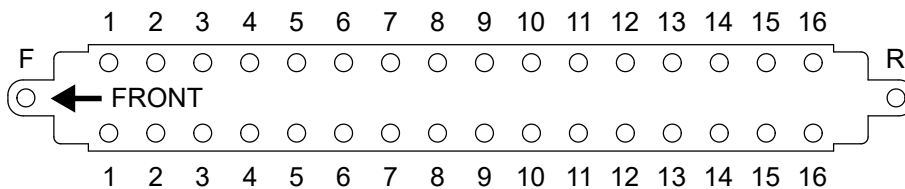

A15i-BUMP can be used as the main lifting accessory for flying vertical arrays of A15i Wide/Focus and KS21i with one or two lifting points.

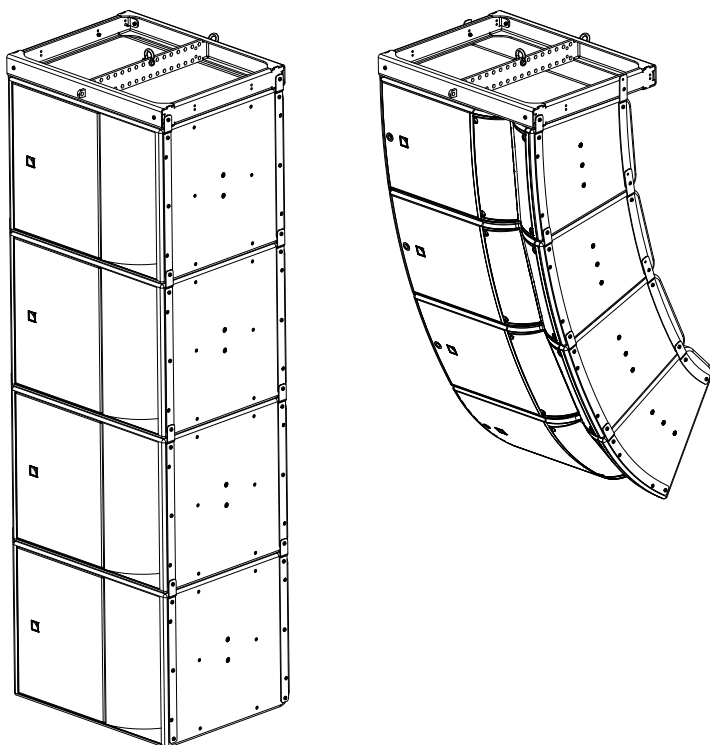

M-BARi

The M-BARi extension bar can be secured on A15i-BUMP to extend the site angle capability of A15i Wide/Focus and KS21i arrays. It can be used as a front or rear extension.

M-BARi is secured to the rigging frame with two rigging axes, nuts, and safety pins.

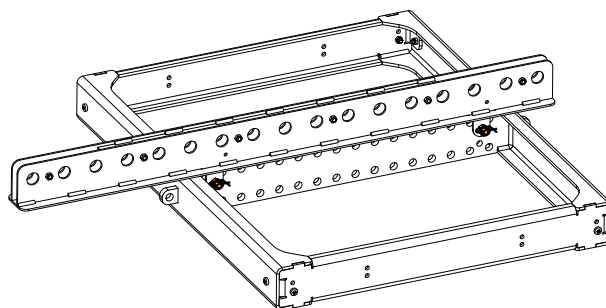
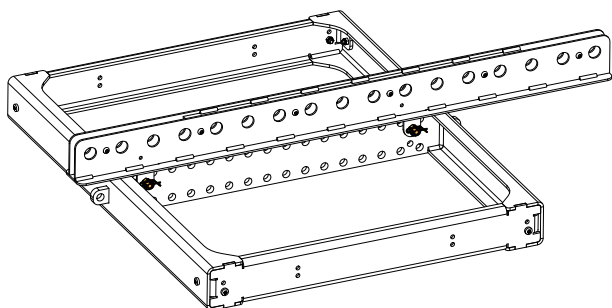
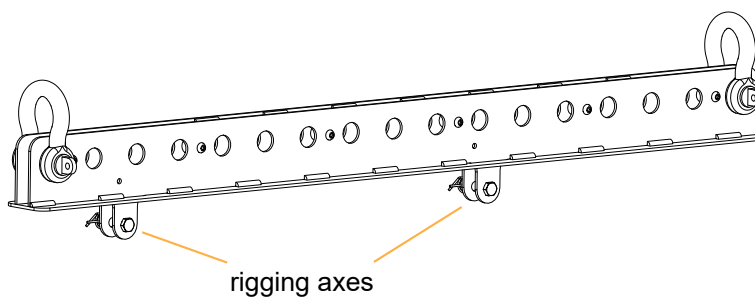

Seventeen pickup points are available. They are compatible with Ø19 mm shackles WLL 3.25 t (two provided).

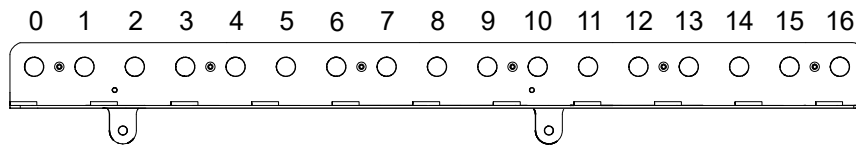

A15i-RIGBAR

A15i-RIGBAR is a rigging bar for pullback configurations.

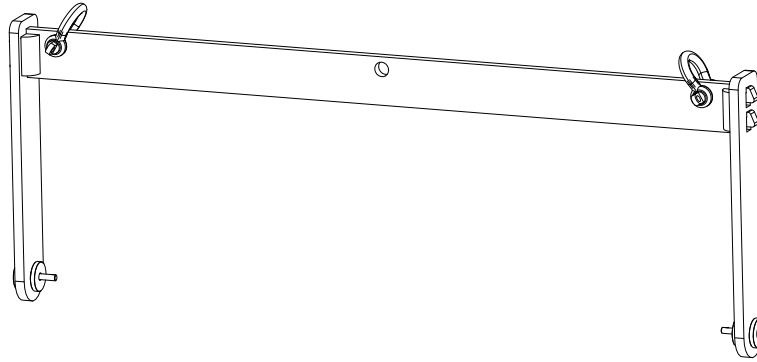

Secured at the bottom of the array, A15i-RIGBAR can be used as a pullback either with A15i-BUMP or with another A15i-RIGBAR as the main lifting accessory.

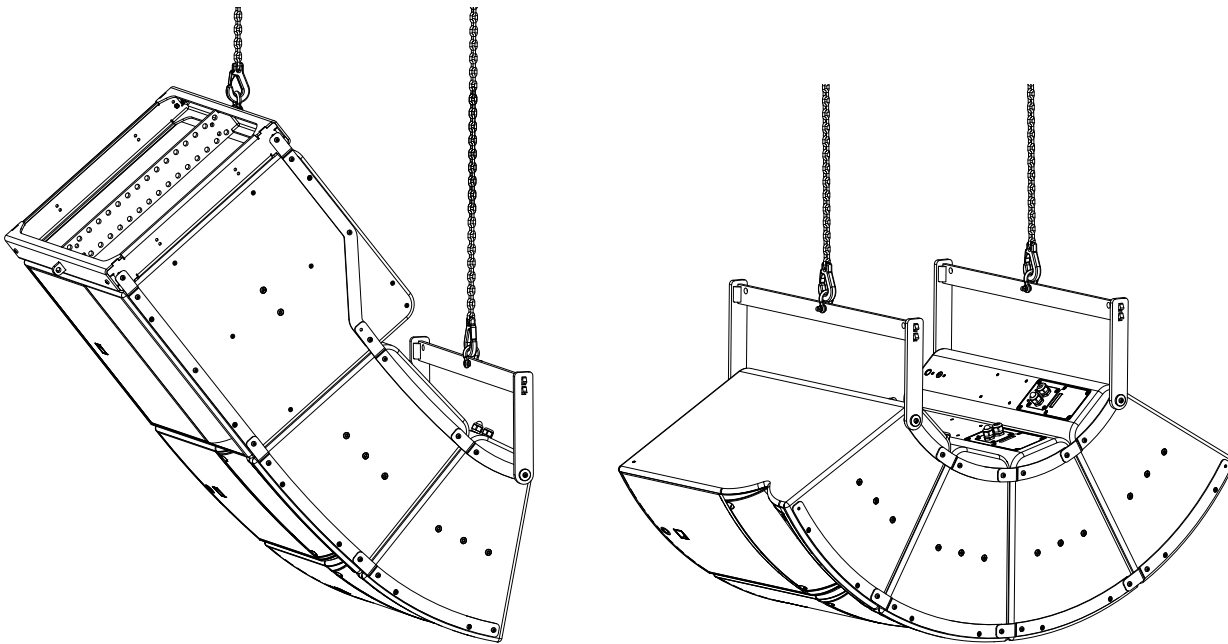

When used at the top of the array as the main lifting accessory, A15i-RIGBAR can be secured at the front for an initial positive site angle.

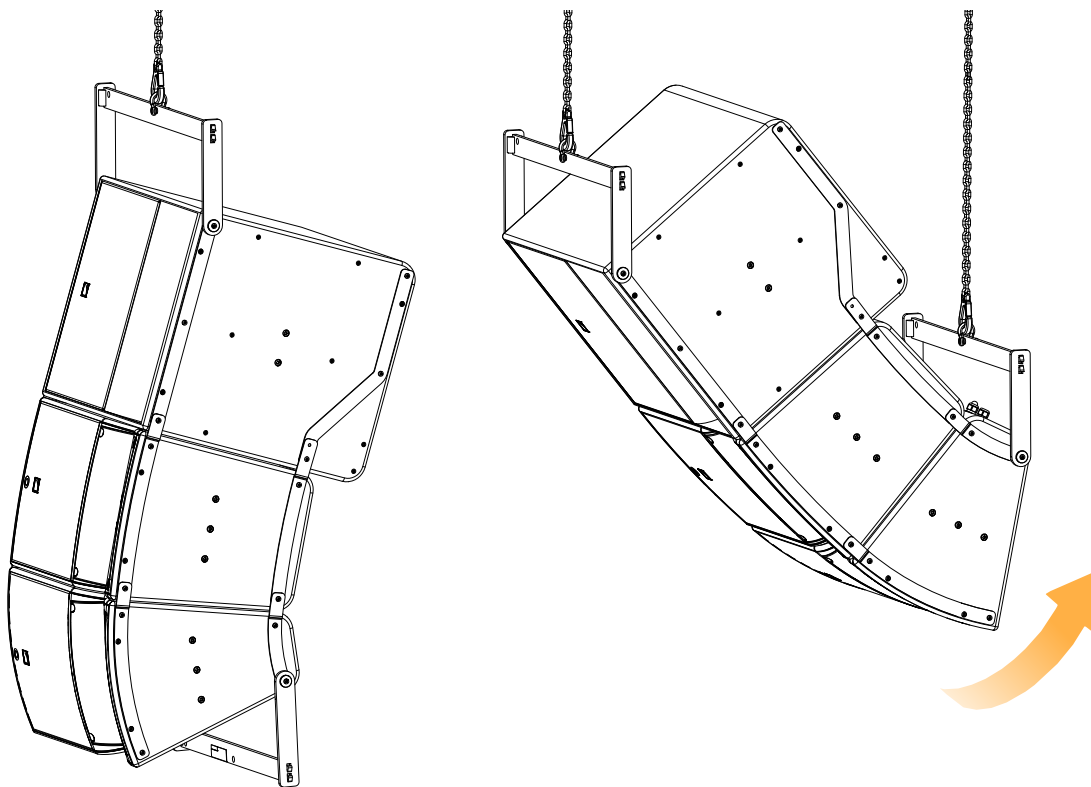

A15i-RIGBAR is secured to the enclosure with two M6x40 screws (provided).

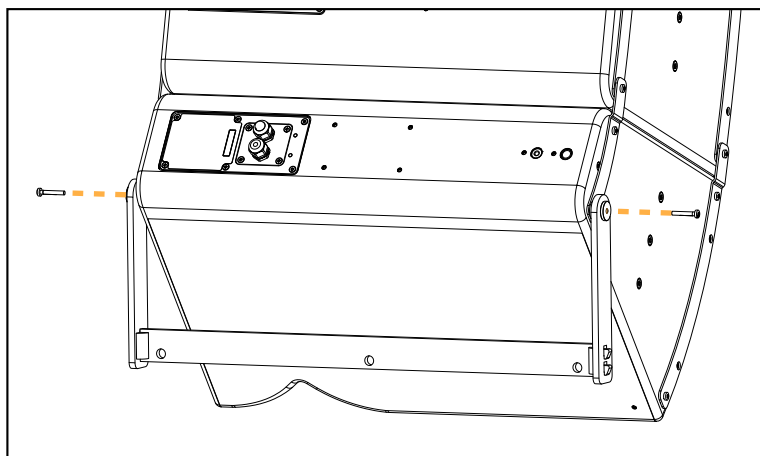

The pickup points are compatible with Ø12 mm shackles WLL 1 t (two provided) and CLAMP250.

! When using A15i-RIGBAR as the main lifting accessory, always implement a secondary safety using available holes.

One pickup point

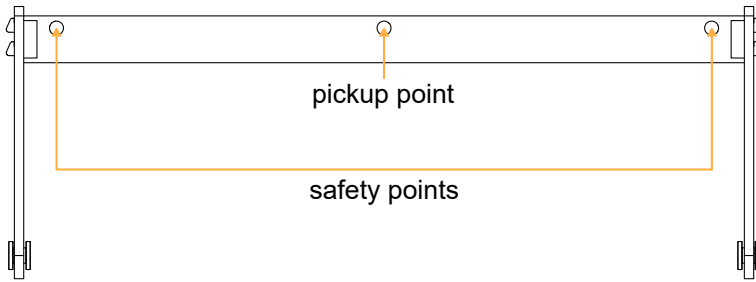

Two pickup points

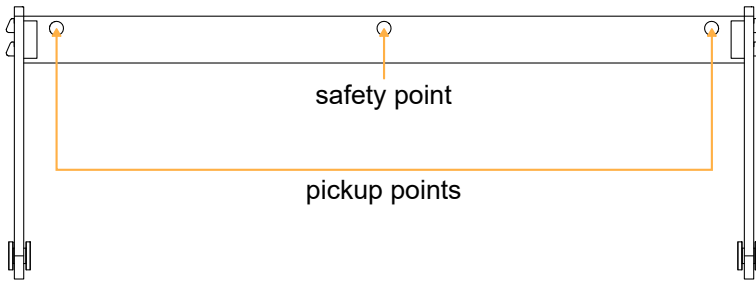

A15i-LIFT

A15i-LIFT is a rigging element designed to fly a radial array of up to three A15i Wide/Focus.

A15i-LIFT features two studs that match the lodgings at the front and rear of the enclosure.

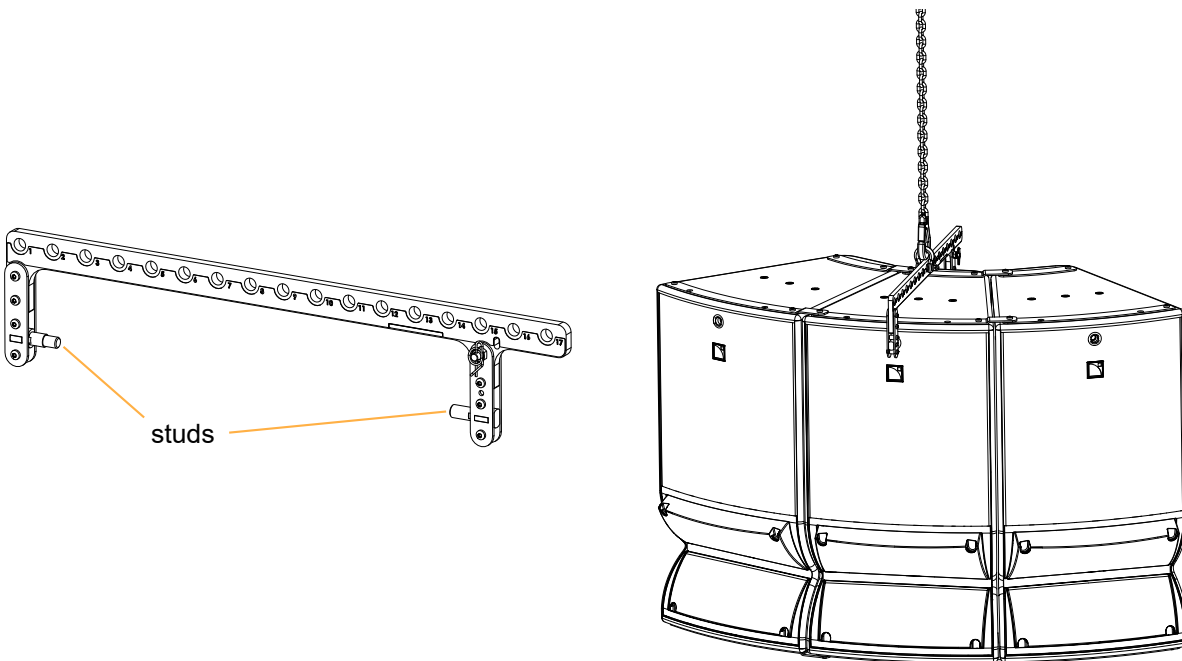

! Additional safety with A15i-LIFT

On each enclosure on which A15i-LIFT is secured, secure a DIN580 eye bolt to the dedicated insert to implement a secondary safety.

Use a shackle and a steel wire rope. Make sure the steel rope is as tensed as possible without bearing the load.

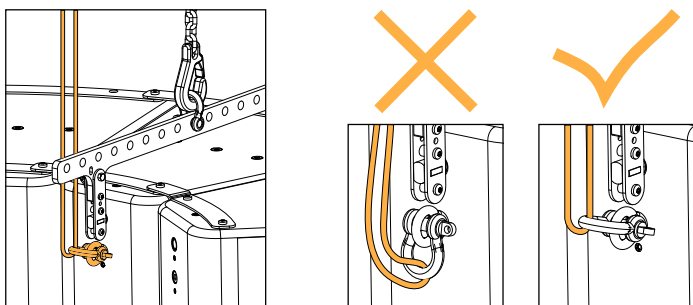

A scalable radial array of A15i Wide/Focus can be created using multiple A15i-LIFT.

! A15i-LIFT quantity and position

Use one A15i-LIFT for up to three enclosures in the array.

Do not leave more than two adjacent enclosures unsupported.

Refer to [APPENDIX A: Authorized configurations with A15i-LIFT](#) (p.151).

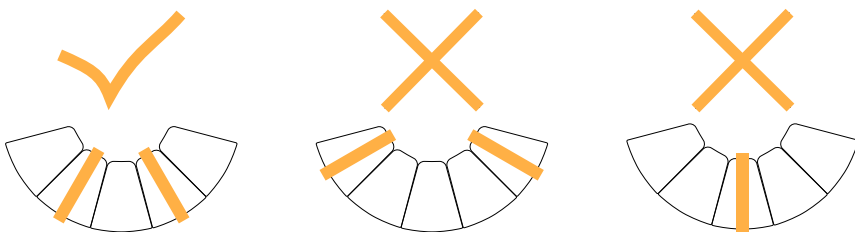

! Risk of tilting

When using a single motor or a bridle, make sure the array is symmetrical.

! When using a third-party bridle, make sure the angle between the two chains does not exceed 60°.

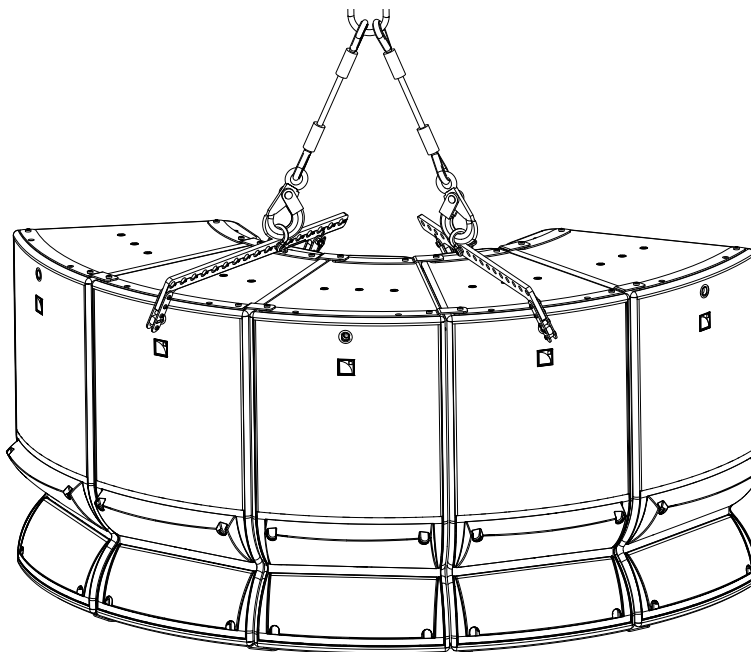

Seventeen holes are available for site angle adjustment. They are compatible with Ø12 mm shackles WLL 1 t (two provided) and CLAMP250.

! A15i-LIFT pickup point

Select the same pickup point on each A15i-LIFT within an array of up to 6 enclosures.
 For larger arrays, refer to [Radial arrays of 7 enclosures and more](#) (p.152).

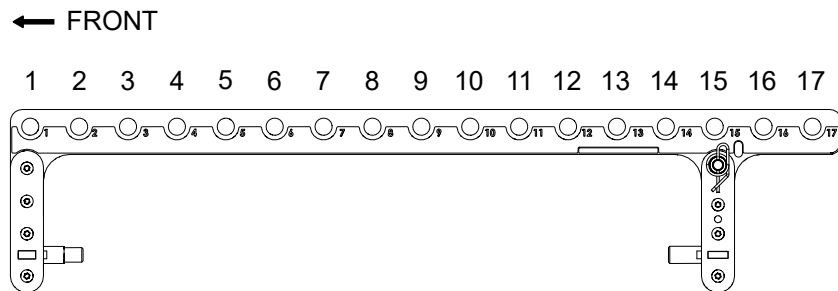

A15iFOCUS-SCREEN-LIFT and A15iWIDE-SCREEN-LIFT are dedicated screens for A15i Wide/Focus enclosures on which A15i-LIFT is secured.

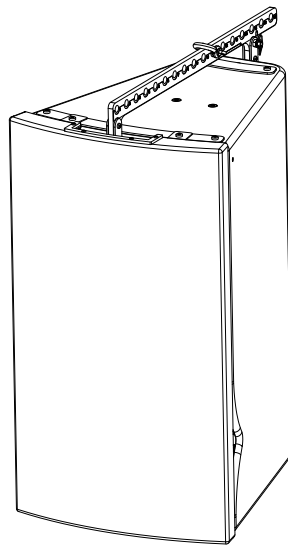

Rigging elements for other configurations

A-U15i

A-U15i is a U-bracket for mounting A15i Wide/Focus or KS21i on a ceiling, a wall, or a truss.

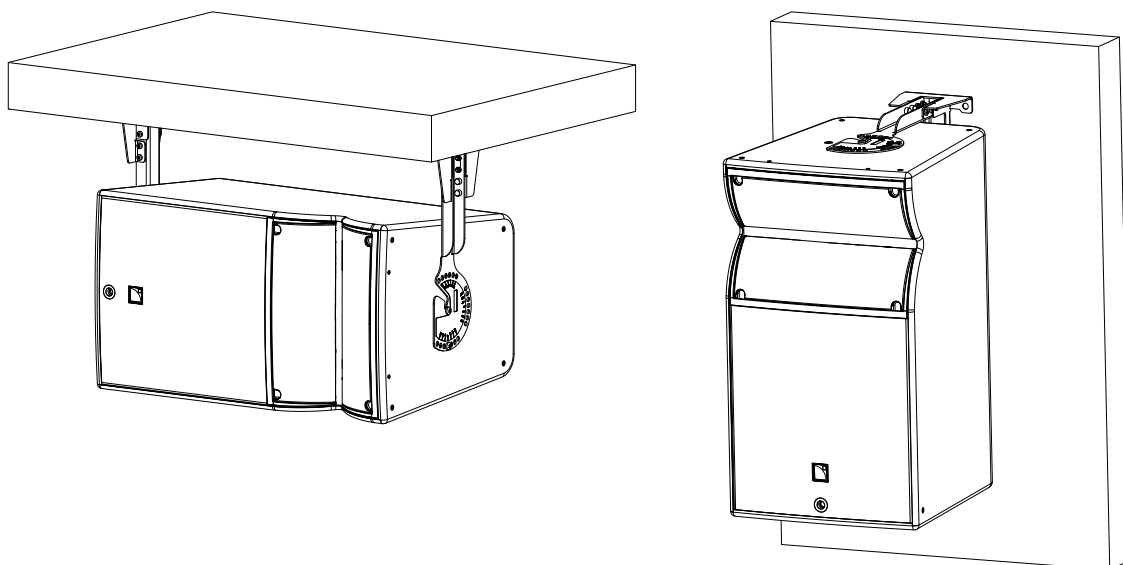

In combination with A15i-ULINK, A15iKS21i-ULINK, or KS21i-ULINK, A-U15i can be used to mount or fly vertical arrays of two A15i Wide/Focus or KS21i.

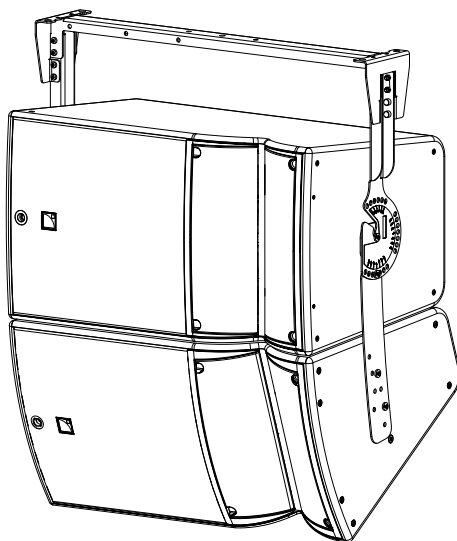

⚠ Do not use rigging plates other than A15i-ULINK / A15iKS21i-ULINK / KS21i-ULINK between two enclosures mounted on A-U15i.

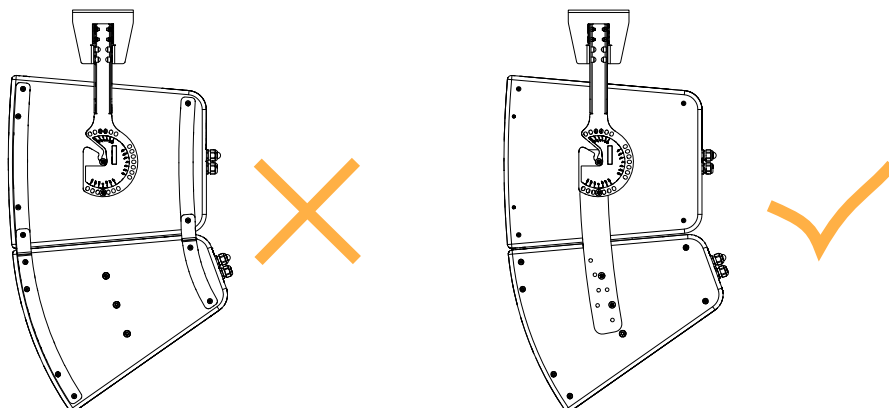

A-U15i is secured to each side of the enclosure by two M8 screws: the central screw and the angulation screw.

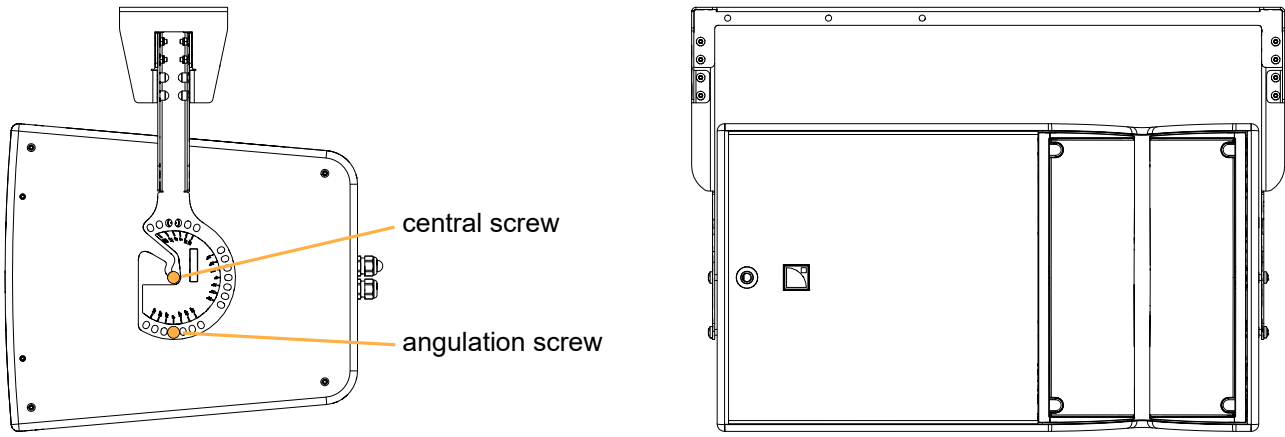

Position the central screw in the bottom insert to reduce space between the enclosure and the ceiling.

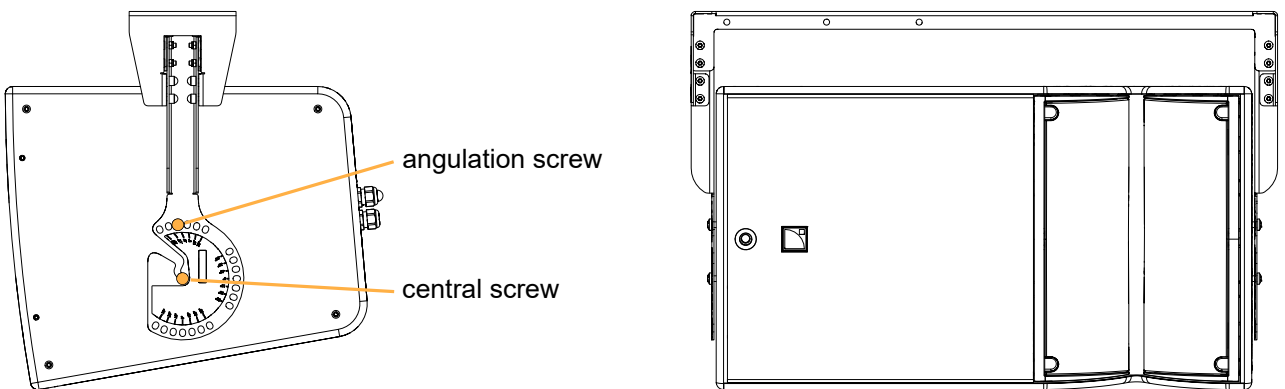

The angle can be set between -30° and $+30^{\circ}$ in 5° or 10° steps. Refer to the label to position the angulation screw. See [APPENDIX B: Configurations with A-U15i](#) (p.153) for a list of authorized configurations.

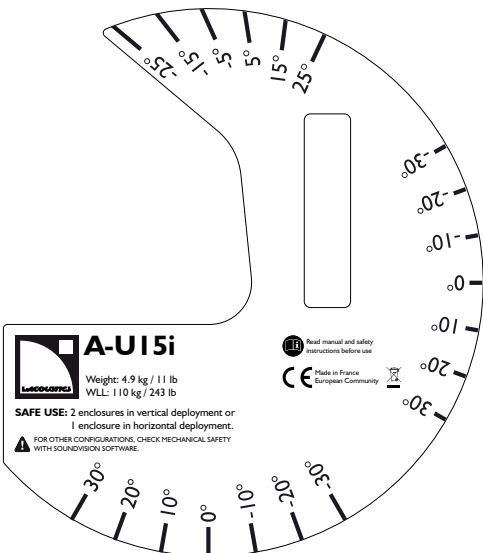

A-U15i must be secured to the supporting fixture with four M10 screws or a truss clamp.

! **Fasteners for wall-mounting or ceiling-mounting**
 Select screw length and anchors applicable to the wall or ceiling properties.

Ai-FIXBRACKET / A15i-TILTBRACKET

Ai-FIXBRACKET is a set of four fastening brackets for A15i Wide/Focus and KS21i. The enclosure is secured to Ai-FIXBRACKET using the slotted hole.

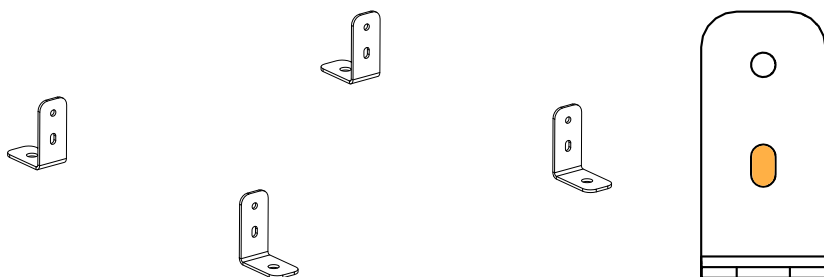

Secure Ai-FIXBRACKET at the bottom of an array to improve stability.

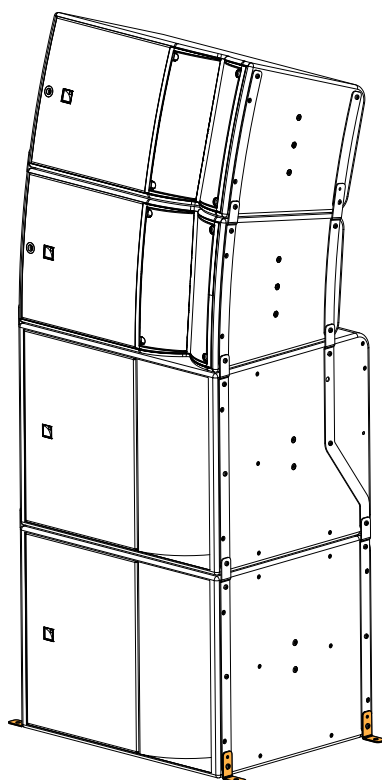

A15i-TILTBRACKET is a set of four fastening brackets with site angle adjustment for a stack of up to four A15i Wide/Focus. The enclosure is secured to A15i-TILTBRACKET using the round hole.

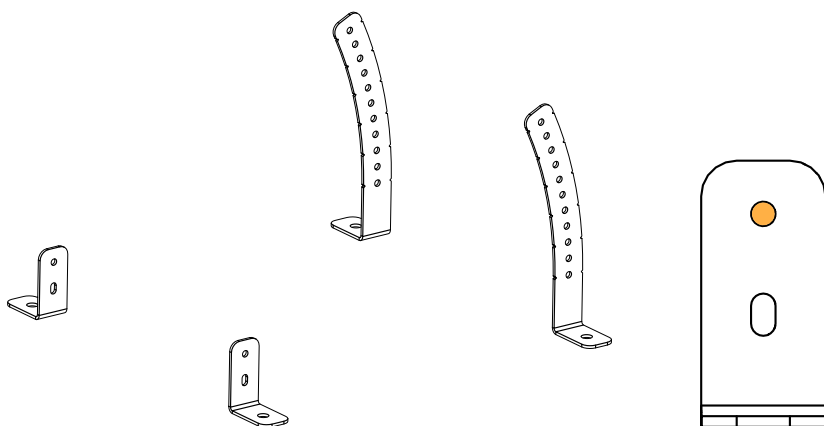

Secure A15i-TILTBRACKET at the bottom of an array of up to two A15i Wide/Focus to adjust the site angle.

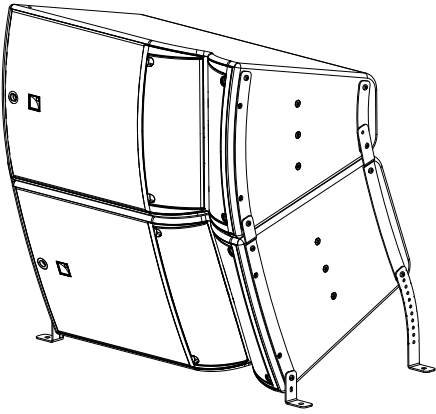

The angle can be set between 0° and -25° in 2.5° steps.

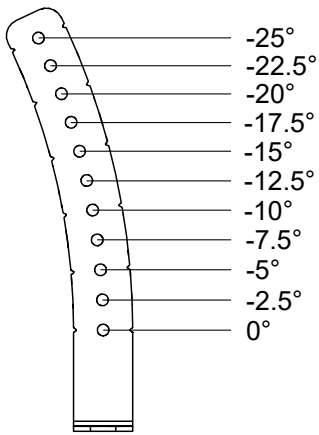

Ai-FIXBRACKET and A15i-TILTBRACKET can also be used to mount up to two A15i Wide/Focus or KS21i under the ceiling.

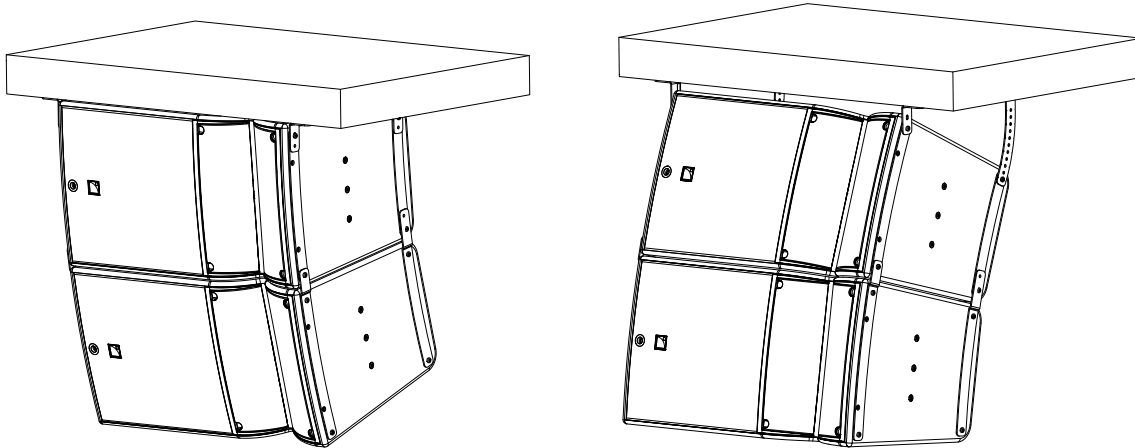

Ai-FIXBRACKET and A15i-TILTBRACKET must be secured to the supporting fixture with four M10 screws.

! Fasteners for wall-mounting or ceiling-mounting
 Select screw length and anchors applicable to the wall or ceiling properties.

A15i-TILT

A15i-TILT is a site angle adjustment accessory for linking KS21i and A15i Wide/Focus in a stacked or flown array.

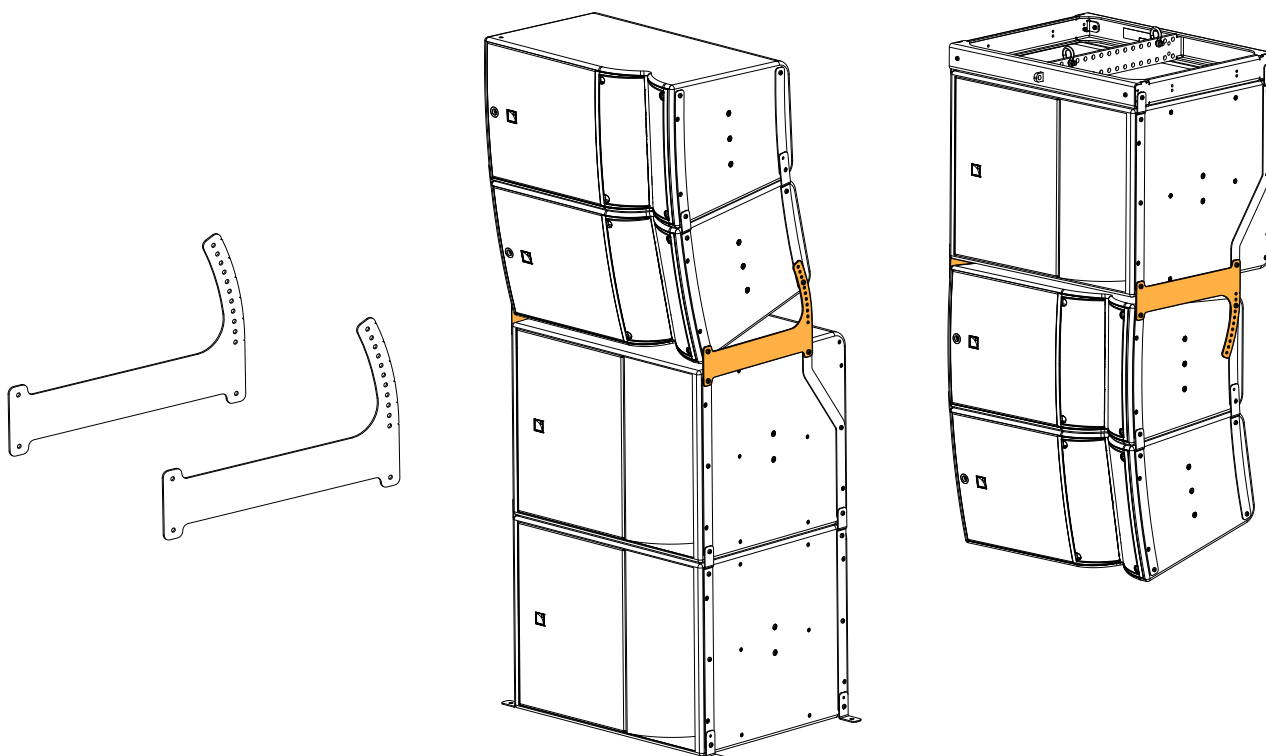

The inter-element angle can be set between 0° and -25° in 2.5° steps.

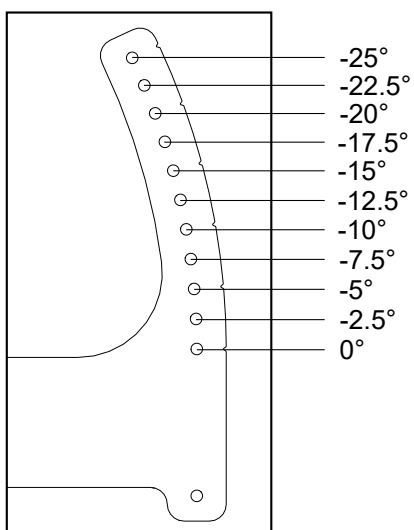

To know the site angle of the first enclosure secured on A15i-TILT, refer to [Realized site angles \(with A15i-TILT at the rear\)](#) (p.96).

Front screens

The A15i system features five acoustically transparent front screens suitable for every configuration.

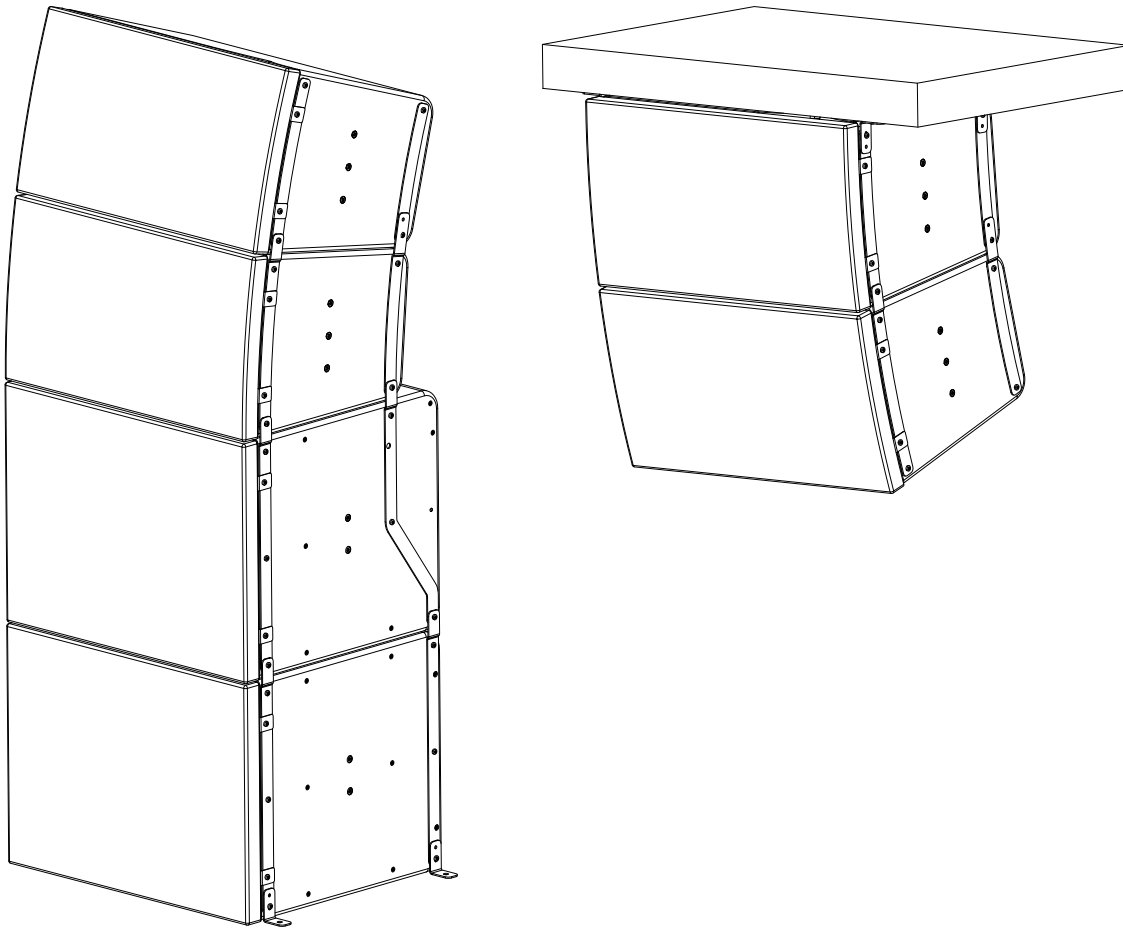

The screens are secured on top of the rigging plates with four M6 rigging screws:

- Two M6x20 screws on the fins side (A15i Wide/Focus) or vent side (KS21i).
- Two M6x35 screws for A15i Wide/Focus or two M6x55 screws for KS21i on the grill side. These two screws are secured in place of the grill screws.

Risk of damaging the fins

When securing a screen to A15i Wide/Focus, make sure to use M6x20 screws on the fins side.

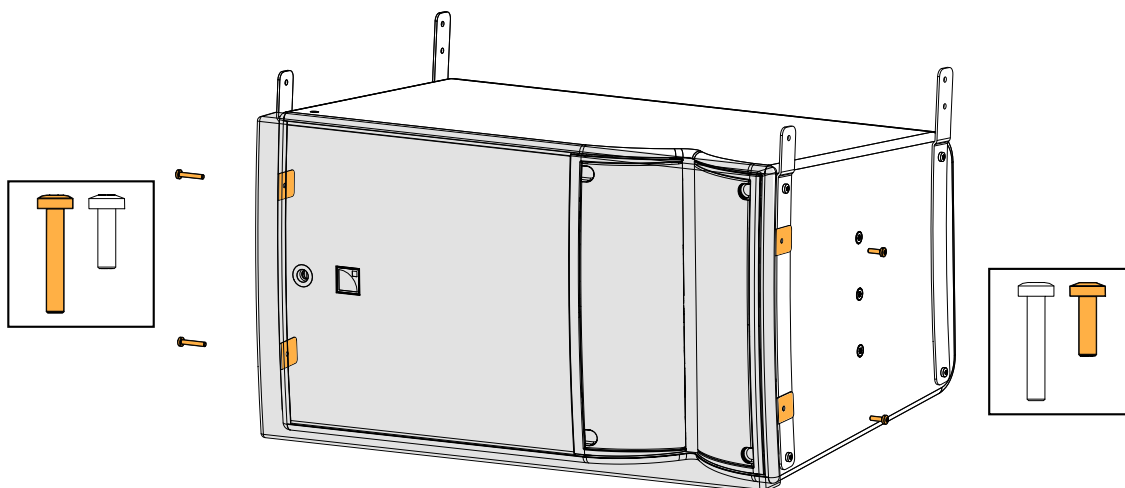

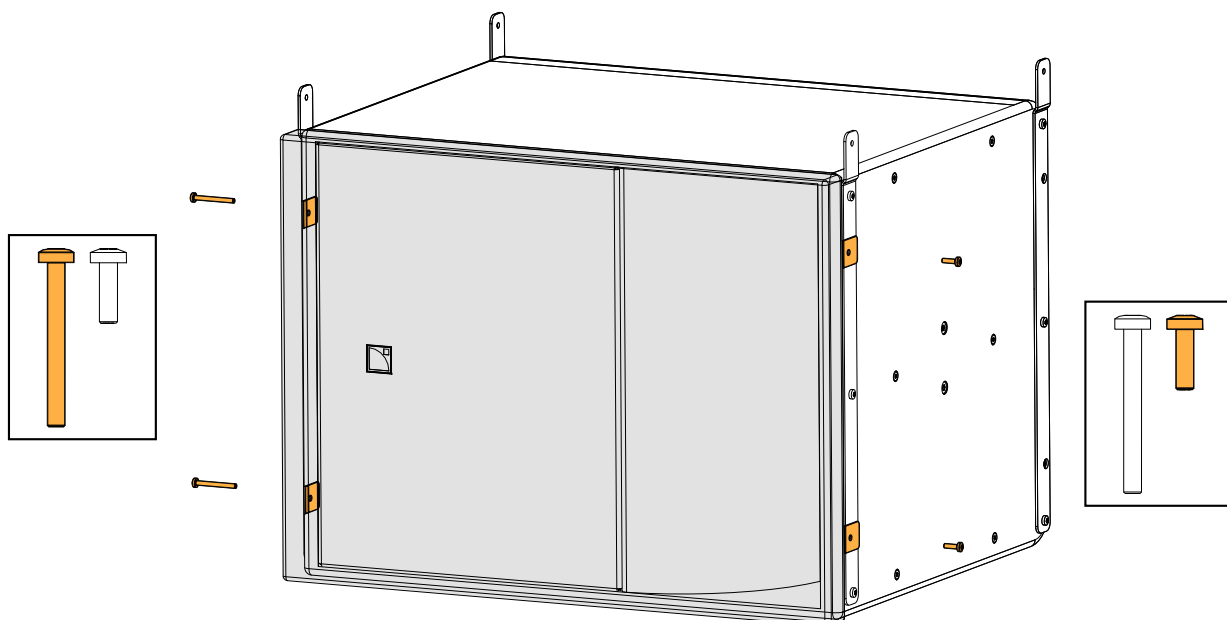

The screws of the grill and the placeholder screws on the fins side can be removed through the rigging plates.

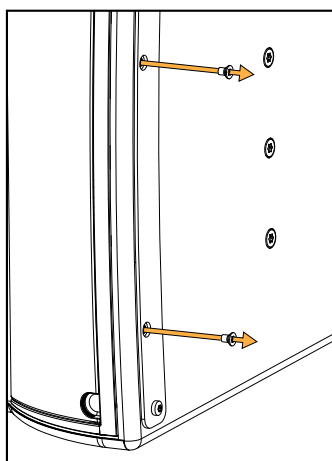

The screens are equipped with tabs to hold the grill in place when securing the screen on the enclosure.

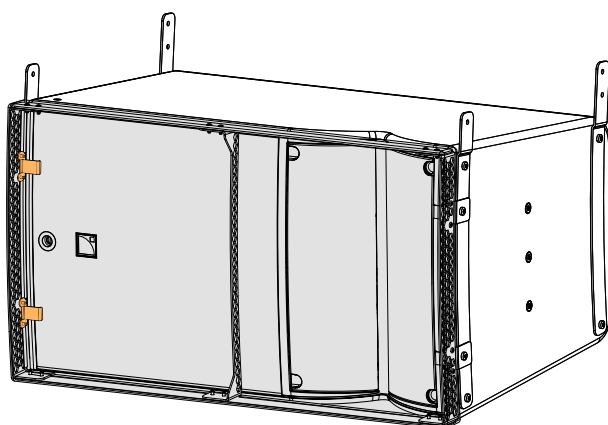

KS21i-SCREEN can be secured to the back of KS21i when used in cardioid configuration. The cable(s) can be passed through a cutout on the screen side.

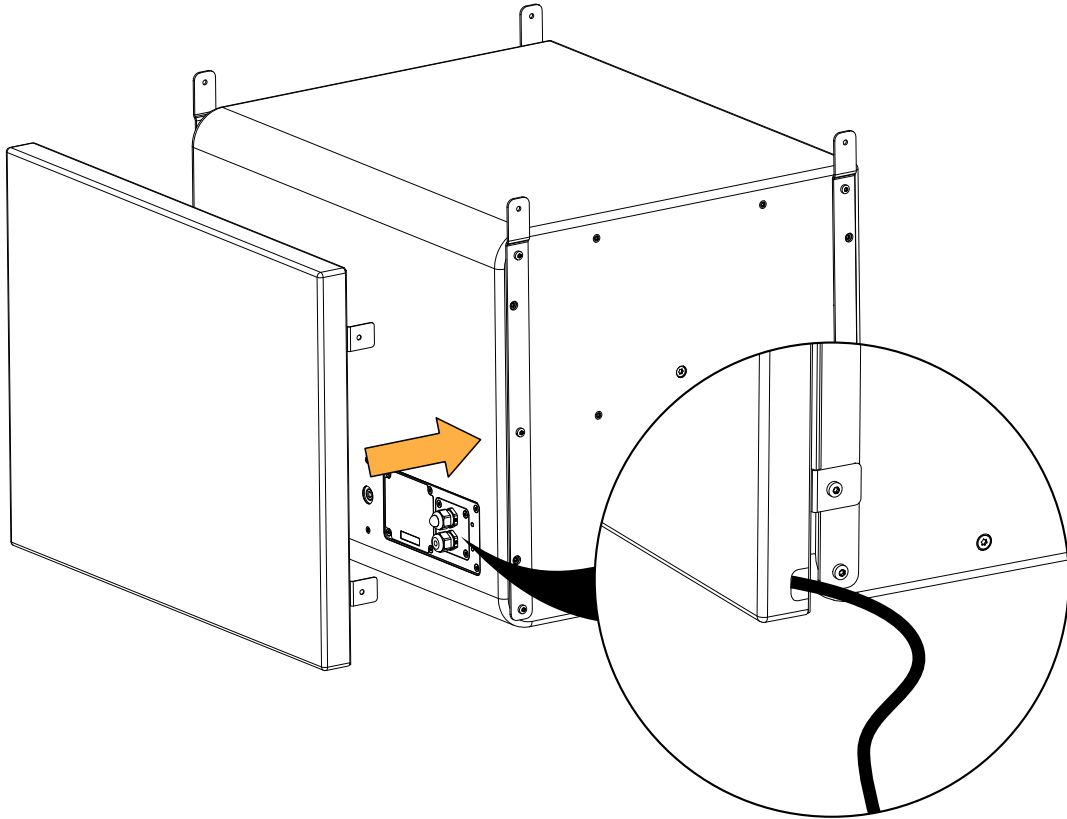

A15iFOCUS-SCREEN-LIFT and A15iWIDE-SCREEN-LIFT are dedicated screens for A15i Wide/Focus flow in radial configurations. The screens are designed to fit on an A15i Wide/Focus enclosure assembled with A15i-LIFT.

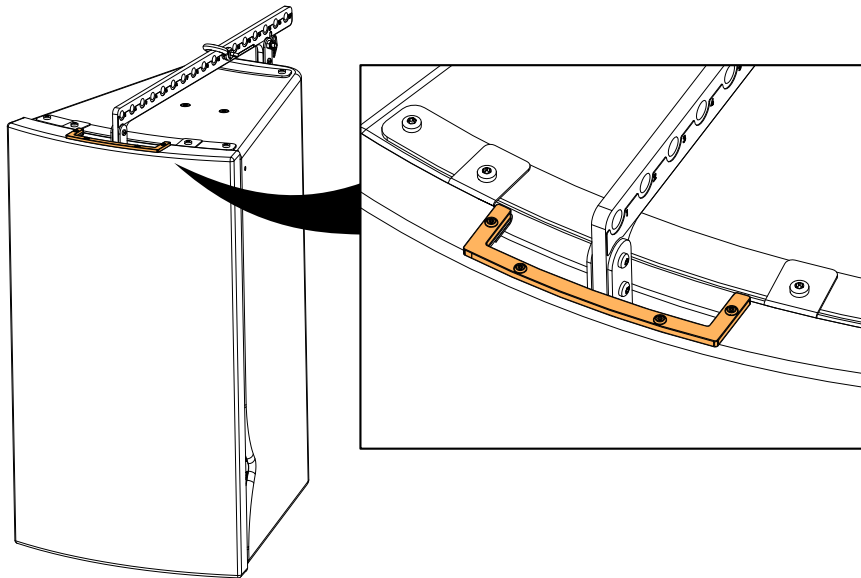

Mechanical safety

Flown configurations

The A15i rigging system complies with 2006/42/EC: Machinery Directive. It has been designed following the guidelines of BGV-C1.

2006/42/EC: Machinery Directive specifies a safety factor of 4 against the rupture. The flown deployments described in this manual achieve a safety factor of **4 or more**.

Refer to Soundvision for the safety factor of a specific deployment.

The **safe limit** gives the maximum number of elements for which the safety factor is compliant with the 2006/42/EC: Machinery Directive, within the use defined in this manual and regardless of the other deployment parameters (site angles, inter-element angles, etc.).

The **maximum limit** gives the maximum number of elements for which the safety factor can be compliant with the 2006/42/EC: Machinery Directive, when the other deployment parameters provide the best mechanical conditions.

For mixed arrays refer to your Soundvision model.

A15i Wide/Focus

configuration	rigging accessory	maximum / safe limit
Vertical array	A15i-BUMP + rigging plates + M-BARi (optional)	8
	A15i-RIGBAR x2 + rigging plates	4
	A-U15i	1
	A-U15i + A15i-ULINK	2
Radial array	1 × A15i-LIFT	1 or 3
	2 × A15i-LIFT	2, 4, 5 or 6
	3 × A15i-LIFT	7, 8 or 9
Wall-mounted (horizontal)	A-U15i	1
	A-U15i + A15i-ULINK	2
Wall-mounted (vertical)	A-U15i	1
Ceiling-mounted	A-U15i + A15i-ULINK or Ai-FIXBRACKET/A15i-TILTBRACKET + rigging plates	2

KS21i

configuration	rigging accessory	safe limit	maximum limit
Vertical array	A15i-BUMP + rigging plates	8	16
	A15i-RIGBAR x2 + rigging plates	4	
	A-U15i	1	
	A-U15i + KS21i-ULINK	2	
Wall-mounted (horizontal)	A-U15i	1	
	A-U15i + KS21i-ULINK	2	
Wall-mounted (vertical)	A-U15i	1	
Ceiling-mounted	A-U15i + KS21i-ULINK or Ai-FIXBRACKET + rigging plates	2	

A15i Wide/Focus under KS21i

configuration	rigging accessory	maximum / safe limit
Wall-mounted (horizontal)	A-U15i + A15iKS21i-ULINK	1 KS21i 1 A15i Wide/Focus
Ceiling-mounted	A-U15i + A15iKS21i-ULINK or Ai-FIXBRACKET + rigging plates	1 KS21i 1 A15i Wide/Focus

Other configurations

For other configurations, respect the recommended maximum limit for optimal stability.

A15i Wide/Focus

configuration	rigging accessory	maximum / safe limit
Stacked vertical array	Ai-FIXBRACKET + rigging plates	4
Stacked vertical array with angle adjustment	A15i-TILTBRACKET + rigging plates	4

KS21i

configuration	rigging accessory	maximum / safe limit
Stacked vertical array with or without Ai-FIXBRACKET	Ai-FIXBRACKET (optional) + rigging plates	4

A15i Wide/Focus on KS21i

configuration	rigging accessory	maximum / safe limit
Stacked on subwoofer	Ai-FIXBRACKET + rigging plates	4 KS21i 4 A15i Wide/Focus
Stacked on subwoofer with angle adjustment	Ai-FIXBRACKET + A15i-TILT + rigging plates	4 KS21i 4 A15i Wide/Focus

Assessing mechanical safety



Mechanical safety of the rigging system

Before any installation, always model the system in Soundvision and check the **Mechanical Data** section for any stress warning or stability warning.

In order to assess the actual safety of any array configuration before implementation, refer to the following warnings:



Rated working load limit (WLL) is not enough

The rated WLL is an indication of the element resistance to tensile stress. For complex mechanical systems such as loudspeaker arrays, WLLs cannot be used per se to determine the maximum number of enclosures within an array or to assess the safety of a specific array configuration.

Maximum pullback angle

If a pullback accessory is available, the pullback angle must not exceed a 90° negative site angle.

Mechanical modeling with Soundvision

The working load applied to each linking point, along with the corresponding safety factor, will depend on numerous variables linked to the composition of the array (type and number of enclosures, splay angles) and the implementation of the flying or stacking structure (number and location of flying points, site angle). This cannot be determined without the complex mechanical modeling and calculation offered by Soundvision.

Assessing the safety with Soundvision

The overall safety factor of a specific mechanical configuration always corresponds to the lowest safety factor among all the linking points. Always model the system configuration with the Soundvision software and check the **Mechanical Data** section to identify the weakest link and its corresponding working load. By default, a stress warning will appear when the mechanical safety goes beyond the recommended safety level.

Safety of ground-stacked arrays in Soundvision

For ground-stacked arrays, a distinct stability warning is implemented in Soundvision. It indicates a tipping hazard when the array is not secured to the ground, stage or platform. It is the user's responsibility to secure the array and to ignore the warning.

Additional safety for flown arrays

When flying an array, use available holes to implement a secondary safety.

Considerations must be given to unusual conditions

Soundvision calculations are based on usual environmental conditions. A higher safety factor is recommended with factors such as extreme high or low temperatures, strong wind, prolonged exposition to salt water, etc. Always consult a rigging specialist to adopt safety practices adapted to such a situation.

Loudspeaker configurations

A15i Wide/Focus line source

In this configuration the system operates over the nominal bandwidth of the enclosures.

The [A15] preset delivers a reference frequency response in medium throw applications.

The A15i Wide/Focus enclosures are driven by the LA2Xi / LA4X / LA8 / LA12X amplified controllers.

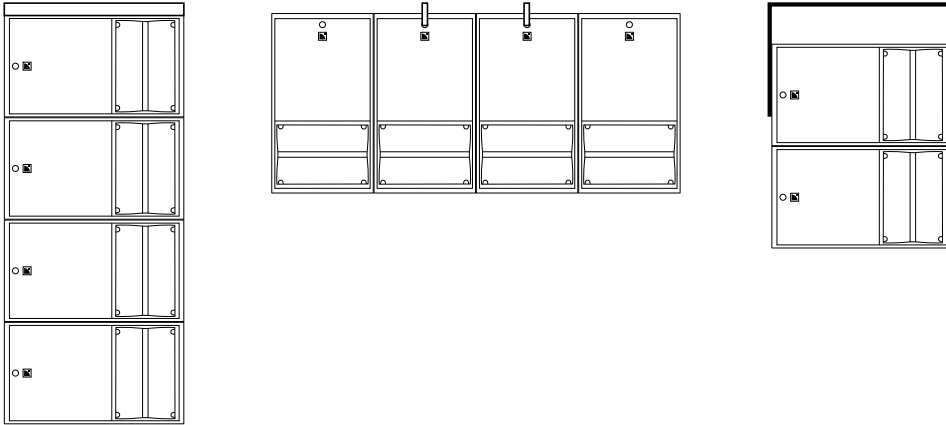

Preset

[A15]

Frequency range (-10 dB)

41 Hz - 20 kHz (A15i Focus)

42 Hz - 20 kHz (A15i Wide)

A15i Wide/Focus line source with low-frequency element

In this configuration, the bandwidth of the A15i system is extended down to 29 Hz and the LF contour is reinforced. The [KS21_60] preset provides KS21i with an upper frequency limit at 60 Hz.

The A15i Wide/Focus and KS21i enclosures are driven by the LA2Xi / LA4X / LA8 / LA12X amplified controllers.

3 A15i Wide/Focus : 2 KS21i

reinforced contour

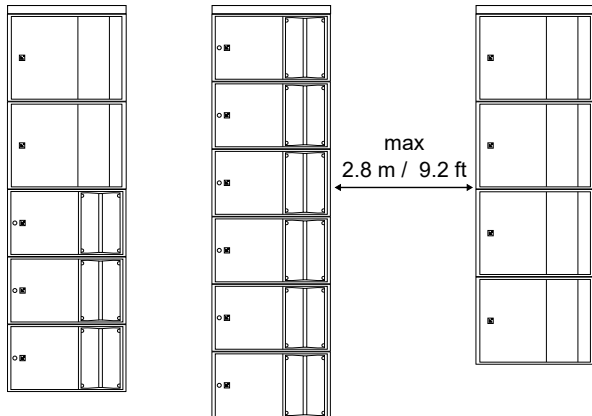

1 A15i Wide/Focus : 1 KS21i

reinforced contour

+ 3 dB at 55 Hz

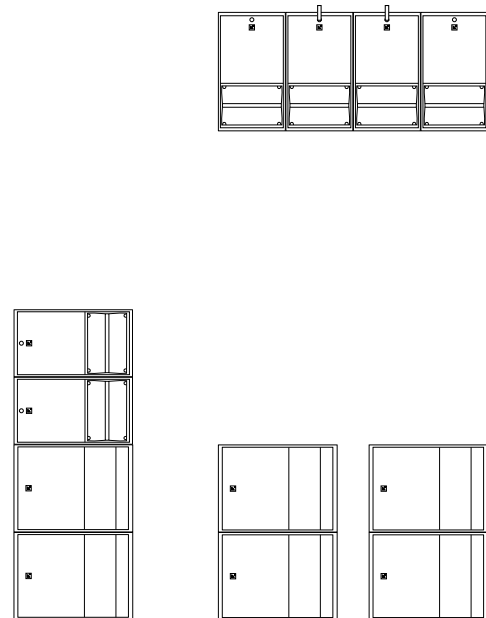

Enclosure	A15i Wide/Focus	KS21i
Preset	[A15]	[KS21_60]
Recommended ratio	1 A15i Wide/Focus : 1 KS21i	
Frequency range (-10 dB)	29 Hz - 20 kHz	

! Use [xxxx_xx_C] or [xxxx_xx_Cx] on a reversed subwoofer in a cardioid configuration

The cardioid configuration consists in reversing 1 element in an array of 4 subwoofers. Refer to the subwoofer owner's manual and to the **Cardioid configurations** technical bulletin.

! Grouping subwoofers

Place the subwoofer enclosures side by side. If not possible, the maximum distance between two adjacent acoustic centers must be 2.8 m or 1.7 m if the upper frequency limit of the subwoofer system is at 60 Hz or 100 Hz, respectively.

! Delay values

Do not forget to add the pre-alignment and geometric delays depending on the configuration.

Pre-alignment delays

presets	pre-alignment delay values and polarity settings		
[A15] or [A15_FI] + [KS21_60]	A15 Wide/Focus = 3.5 ms	+	KS21 = 0 ms
[A15] or [A15_FI] + [KS21_60_C]	A15 Wide/Focus = 9 ms	+	KS21 = 0 ms

presets	pre-alignment delay values and polarity settings	
[A15] or [A15_FI] + [KS21_60_Cx]	A15 Wide/Focus = 8 ms <input data-bbox="965 174 1013 230" type="button" value="+"/>	KS21 = 0 ms <input data-bbox="1444 174 1492 230" type="button" value="+"/>

A15i Wide/Focus line source element

A single A15i Wide/Focus can be used as a line source element. In this configuration, the system operates over the nominal bandwidth of the enclosure.

The [A15_FI] preset delivers a reference frequency response in short throw applications.

The A15i Wide/Focus enclosures are driven by the LA2Xi / LA4X / LA8 / LA12X amplified controllers.

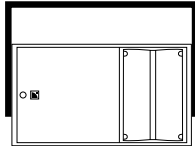
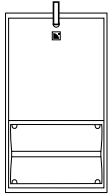

Preset

[A15_FI]

Frequency range (-10 dB)

42 Hz - 20 kHz (A15i Focus)

43 Hz - 20 kHz (A15i Wide)

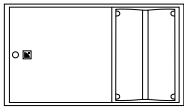

A15i Wide/Focus line source element with low-frequency element

With a complementary subwoofer, the system is extended in the low end and the LF contour is reinforced.

The [A15_FI] preset delivers a reference frequency response in short throw applications. The [KS21_60] preset provides KS21i with an upper frequency limit at 60 Hz.

The A15i Wide/Focus and KS21i enclosures are driven by the LA2Xi / LA4X / LA8 / LA12X amplified controllers.

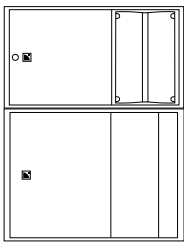

Enclosure

A15i Wide/Focus

KS21i

Preset

[A15_FI]

[KS21_60]

Recommended ratio

1 A15i Wide/Focus : 1 KS21i

Frequency range (-10 dB)

29 Hz - 20 kHz



Use [xxxx_xx_C] or [xxxx_xx_Cx] on a reversed subwoofer in a cardioid configuration

The cardioid configuration consists in reversing 1 element in an array of 4 subwoofers.

Refer to the subwoofer owner's manual and to the **Cardioid configurations** technical bulletin.



Grouping subwoofers

Place the subwoofer enclosures side by side. If not possible, the maximum distance between two adjacent acoustic centers must be 2.8 m or 1.7 m if the upper frequency limit of the subwoofer system is at 60 Hz or 100 Hz, respectively.

**Delay values**

Do not forget to add the pre-alignment and geometric delays depending on the configuration.

Pre-alignment delays

presets	pre-alignment delay values and polarity settings			
[A15] or [A15_FI] + [KS21_60]	A15 Wide/Focus = 3.5 ms	+	KS21 = 0 ms	-
[A15] or [A15_FI] + [KS21_60_C]	A15 Wide/Focus = 9 ms	+	KS21 = 0 ms	-
[A15] or [A15_FI] + [KS21_60_Cx]	A15 Wide/Focus = 8 ms	+	KS21 = 0 ms	+

Inspection and preventive maintenance

How to do preventive maintenance

Inspect the system after any corrective maintenance operation.

Perform preventive maintenance at least once a year.

Refer to the maintenance manuals for advanced maintenance.

Rigging and hardware

Perform the [Rigging part inspection](#) (p.51) on each rigging part.

Use the [Mechanical system overview](#) (p.51) to identify critical parts of the system.

If any parts are damaged, contact your L-Acoustics representative for further instructions.

Acoustics

Perform the [Enclosure check](#) (p.55).

Perform the [Listening test](#) (p.57) to detect any degradation in sound quality.

If necessary, refer to the [Corrective maintenance](#) (p.113) section for speaker repair kits and maintenance instructions.

Rigging part inspection

About this task

The term "rigging part" comprises:

- lifting accessories such as clamps and shackles
- rigging accessories such as rigging frames, rigging interfaces, and brackets
- fasteners used for assembling two products together such as ball-locking pins, rigging axes, and safety pins
- rigging plates mounted on enclosures
- screens mounted on enclosures

This inspection procedure covers only L-Acoustics products. To inspect other products that are part of the lifting chain, refer to the manufacturer's instructions.

Prerequisite

Perform the inspection in a well-lit environment.

Procedure

1. Check that the rigging part is present.
2. Check for:
 - corrosion
 - wear and cracks
 - bends and dents
 - holes
 - missing safety cues
 - missing identification labels
 - missing or loose fasteners



Replacing screws

If a screw is loose, remove and replace it.

Always use the new screws provided in the repair kit.

If no new screw is available, add blue threadlocker before reusing the screw.

Do not apply more than the indicated torque.

3. Check the geometry of the part to identify critical deformations.

What to do next

If a problem is detected, perform the authorized maintenance operations or contact your L-Acoustics representative.

Mechanical system overview

Critical parts of the lifting chains are highlighted.



The  indicates a visual inspection.



Perform the [Rigging part inspection](#) (p.51) on critical parts.



Replacing screws

If a screw is loose, remove and replace it.

Always use the new screws provided in the repair kit.

If no new screw is available, add blue threadlocker before reusing the screw.

Do not apply more than the indicated torque.

A15i Wide/Focus and KS21i array with A15i-BUMP and M-BARi

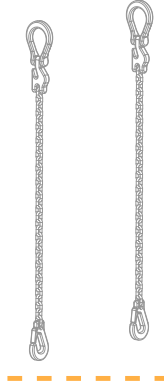

shackle axis end is flush with the shackle

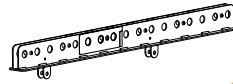
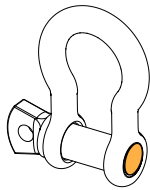

rigging axes are secured with nuts and safety pins



nuts are secured and tightened

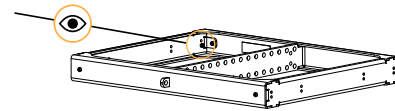

Rigging part inspection (p.51)

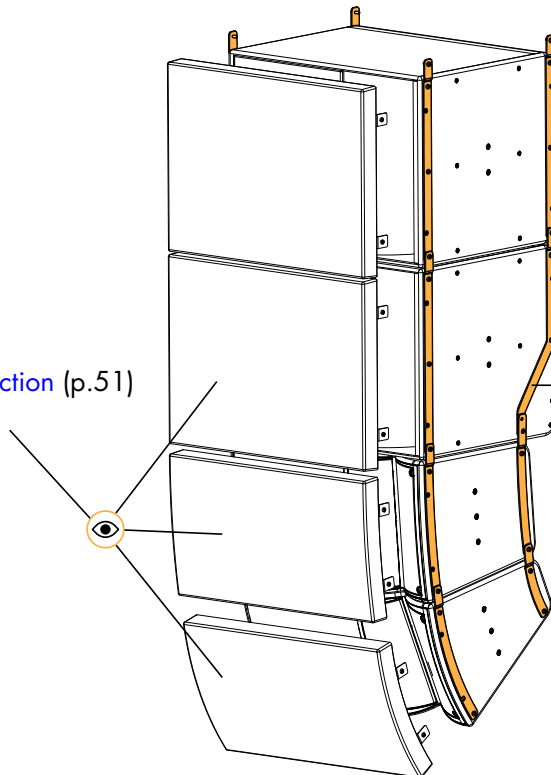

Rigging part inspection (p.51)

A15i Wide/Focus array with A15i-LIFT

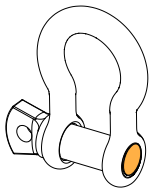

shackle axis end is flush with the shackle

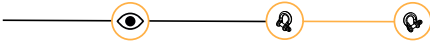

the studs are not bent



rigging axes are secured with nuts and safety pins

Rigging part inspection (p.51)

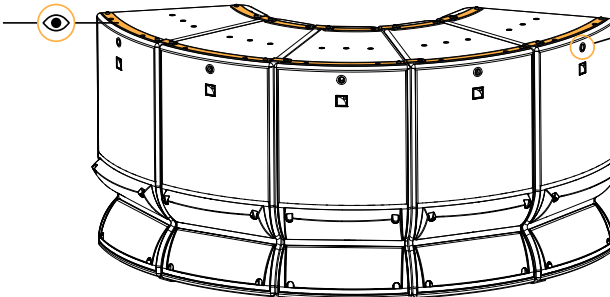

the front and rear inserts are not damaged

A15i Wide/Focus ceiling-mounted with A-U15i

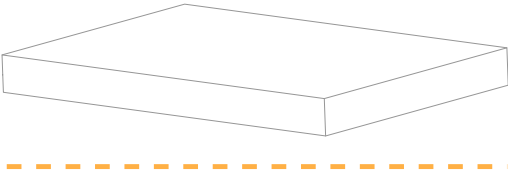

the supporting screws are tightened

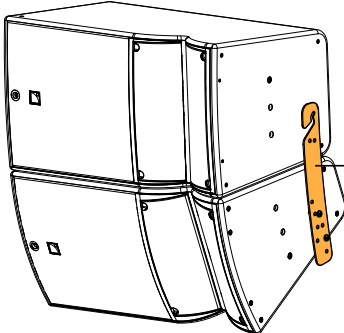
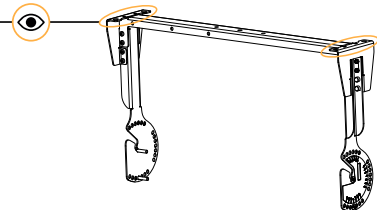

Rigging part inspection (p.51)

A15i Wide/Focus ceiling-mounted with Ai-FIXBRACKET

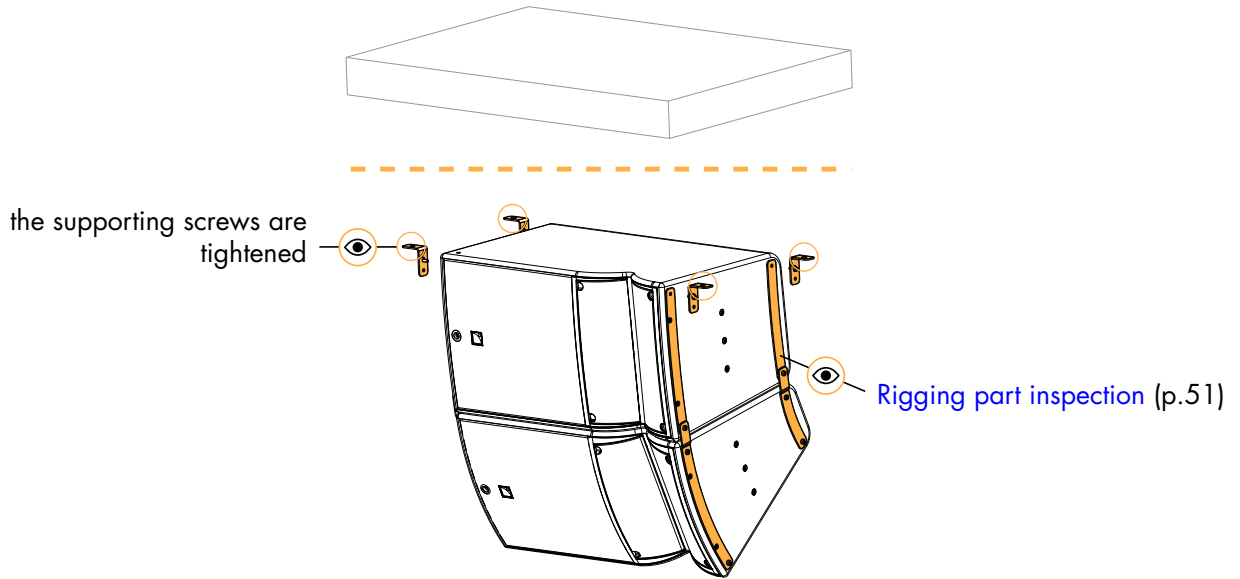

A15i Wide/Focus stacked on KS21i

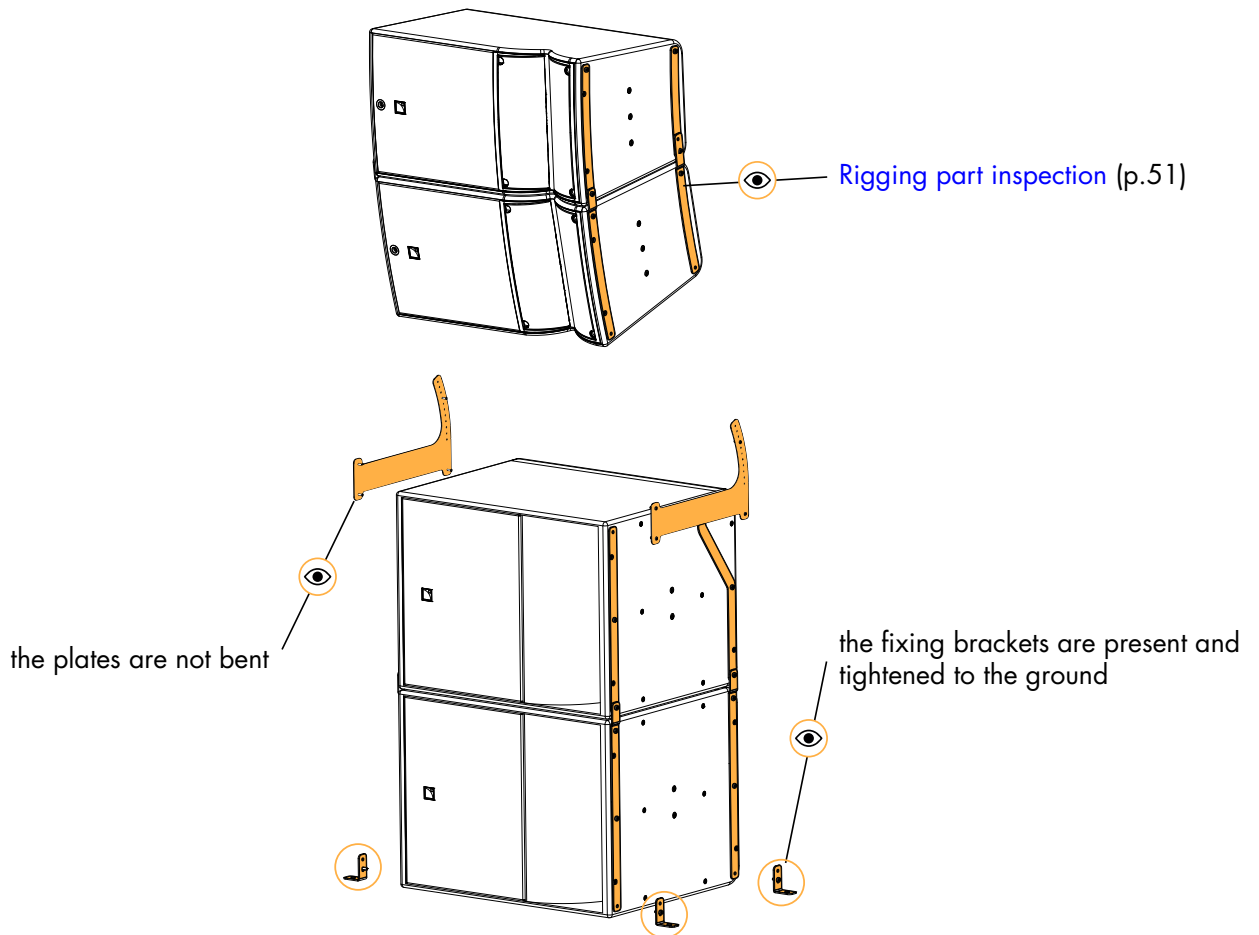

Acoustical check

Enclosure check



This feature is available on:

LA4X
LA12X

ENCLOSURE CHECK measures impedance at the reference frequencies for the connected loudspeaker family. The measured impedance is compared to the expected range allowing for fast detection of loudspeakers presenting circuit continuity issues.



The results can be used for preliminary diagnosis but cannot replace a comprehensive quality control.

Prerequisite



ENCLOSURE CHECK measurements can only be reliable if the following requirements are met:

Environment and temperature:

- Ambient temperature must be comprised between 0 °C / 32 °F and 40 °C / 104 °F. Ideal temperature is 20 °C / 68 °F.
- Enclosures must be at room temperature. If warm from a recent high level use or recently moved from a cold environment, let the loudspeakers reach room temperature before starting.

Enclosures:

- Enclosures must be included in the embedded factory preset library.
- Enclosures must be in nominal operating conditions:
 - Remove covers or dollies obstructing the loudspeakers or the vents.
 - Check for obvious physical damage or air leak: visually inspect the grill, gasket, cabinet, and connector plate for loose, missing or damaged parts.

Connection:

- Use only 10 m / 30 ft 4 mm² / AWG 11 speaker cables.
- Do not connect enclosures in parallel.

Amplified controllers:

- LA4X must run at least firmware version 1.1.0.
- LA4X load sensors must be calibrated. Refer to the **Load Sensor Calibration Tool** technical bulletin for more information.
- LA4X must warm up for at least 10 minutes after power up. Do not power off, reboot or switch to standby mode to avoid resetting the countdown.
- Load a preset corresponding to the connected loudspeaker's family. Presets from the user memories may be used on condition they are made of presets supported in the embedded factory preset library.

Procedure

1. Power up the amplified controller. Let LA4X warm up for at least 10 minutes.
2. Connect the loudspeaker enclosures to the amplified controller.
3. Load a preset from or built from the embedded library corresponding to the connected loudspeaker family.
4. On the amplified controller, use the encoder wheel to select **MONITORING & INFO**. Press the OK key or the encoder wheel to validate.
5. Use the encoder wheel to select **ENCLOSURE CHECK**.



Beware of sound levels.

Although the sound pressure levels generated for the ENCLOSURE CHECK are moderate, do not stay within close proximity of the loudspeakers and consider wearing ear protection.

6. Press the OK key or the encoder wheel to launch the ENCLOSURE CHECK.

The amplified controller generates short sinusoidal signals simultaneously for each connected output.

The amplified controller displays the results for each output.

7. Depending on the displayed results, follow the instructions in the table.

result	interpretation	instructions
OK	measured impedance is within expected range	enclosure is in working order electrically
?	unsupported preset family	only supported enclosures should be tested
NC	Not Connected	if cables are connected: a. inspect the cables and connections b. go to step 8 (p.56)
NOK	measured impedance is not within expected range	a. check that all the prerequisites are met, in particular that the loaded preset corresponds to the connected speaker's family b. inspect the cables and connections c. go to step 8 (p.56)
UNDEF	measured impedance is undefined	

8. Under NC, NOK and UNDEF results, press and hold the corresponding OUT key.

The amplified controller displays:

- the tested frequencies,
- information on the measured impedance:
 - OPEN for open circuit (found in NC results),
 - SHORT for short circuit (found in NOK results), or
 - a percentage of variation from the expected range (found in NOK and UNDEF results)
- the number of operational transducers out of the total

 Low variations from the expected range are acceptable: displayed percentage can be different from 0 and all transducers considered operational.

Listening test

enclosure	preset	usable bandwidth
A15i Focus	[A15]	41 Hz - 20 kHz
A15i Wide	[A15]	42 Hz - 20 kHz
KS21i	[KS21_100]	31 Hz - 100 Hz

Procedure

1. Load the preset on an LA2Xi / LA4X / LA8 / LA12X amplified controller.
2. Connect a sinus generator to the amplified controller.



Risk of hearing damage

Set a low sound level to start and use ear protection to adjust before testing.

3. Scan the bandwidth focusing on the usable range.
The sound should remain pure and free of unwanted noise.

Troubleshooting for LF speakers

One or more LF speaker produces distorted, buzzing, rubbing, clicking, muffled or weak sound.

Possible causes

- The screws are not tightened with the appropriate torque.
- There is an air leak in the gasket.
- There is dust on the cone.
- The cone is damaged.
- The surround is torn or delaminated.
- The voice coil or the spider is damaged.

Procedure

1. Perform the speaker disassembly procedure.
2. Visually inspect the cables and the connectors.
3. Visually inspect the speaker cone, the voice coil and the spider.

If any damage is visible, replace the speaker.

4. Carefully clean the speaker with a dry cloth.
5. Perform the reassembly procedure.
Replace the speaker gasket and the screws.
Apply the recommended torque.

6. Repeat the listening test.

If the problem persists, replace the speaker.

Troubleshooting for HF drivers

One or more HF driver produces high-frequency harmonic distortions, strange vibrations or weak sound.

Possible causes

- There are foreign particles on the air gap.
- The diaphragm is not centered correctly.
- The screws used for reassembly are too loose.
- The diaphragm is damaged.
- The number of shims is wrong.

Procedure

1. Perform the diaphragm disassembly procedure.
2. Visually inspect the diaphragm and the voice coil.
If any damage is visible, replace the diaphragm.
3. Clean the air gap thoroughly.
Use double-face adhesive tape to remove any particles.
4. Perform the diaphragm reassembly procedure.
Pay close attention to the number of shims and the position of the diaphragm.
Apply the recommended torque.
5. Repeat the listening test.



If a buzzing sound is still audible, it might be necessary to add an extra shim on the air gap.

If the problem persists, replace the driver.

Rigging procedures

General principles

Because of the highly-modular nature of the rigging system, not all possible configurations are described in the rigging procedures. This introduction provides general principles applicable for all configurations.

References

For information on radial configurations with A15i-LIFT, refer to [APPENDIX A: Authorized configurations with A15i-LIFT](#) (p.151).

For information on wall-mounted or ceiling-mounted configurations with A-U15i, refer to [APPENDIX B: Configurations with A-U15i](#) (p.153).

To know the site angle of the first enclosure secured on A15i-TILT, refer to [Realized site angles \(with A15i-TILT at the rear\)](#) (p.96).

Securing rigging plates on an enclosure

- Follow the curvature of the front of the enclosure when securing the rigging plates.

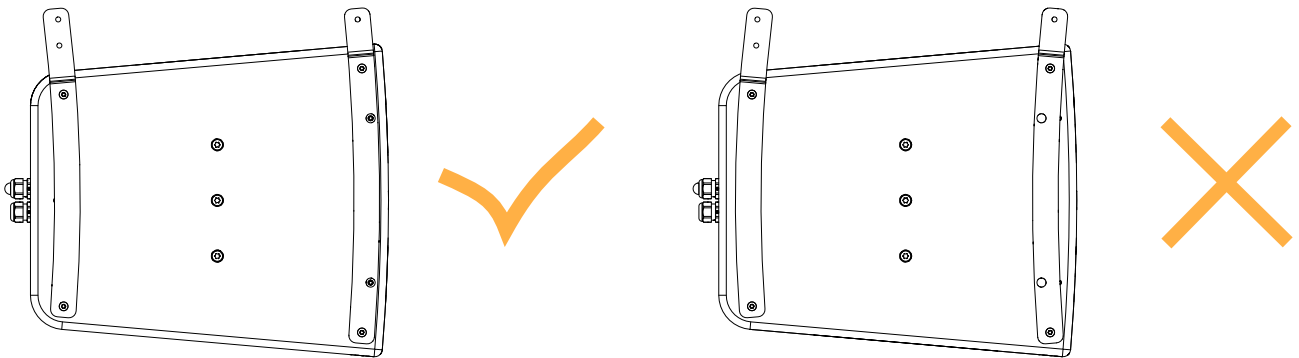

- Make sure that the inserts for the screens are accessible.

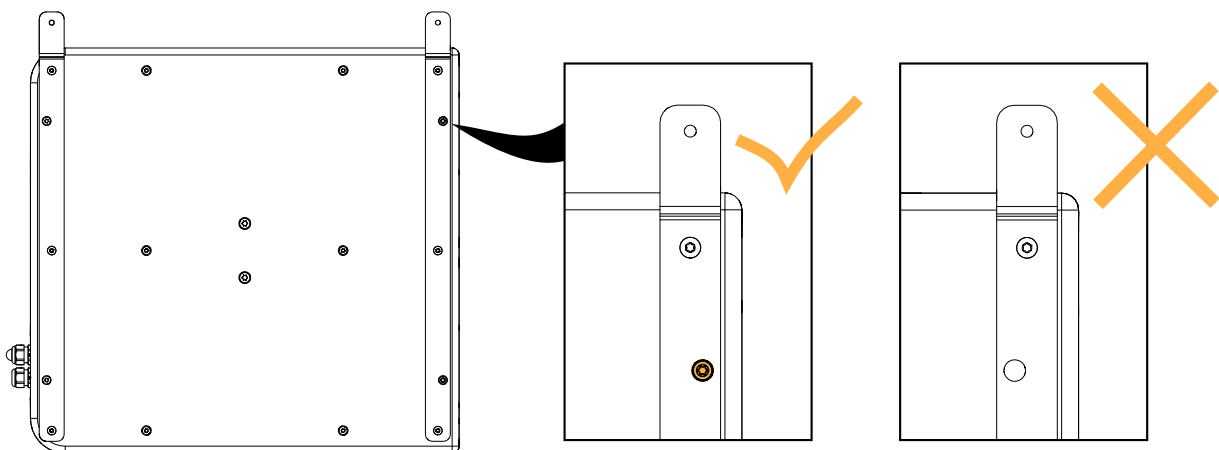

! Driving screws

Do not fully tighten the screws unless otherwise instructed.
Follow the indicated torque when tightening a screw.

Securing rigging plates between two enclosures

- Always secure standard rigging plates with the linking section upwards.

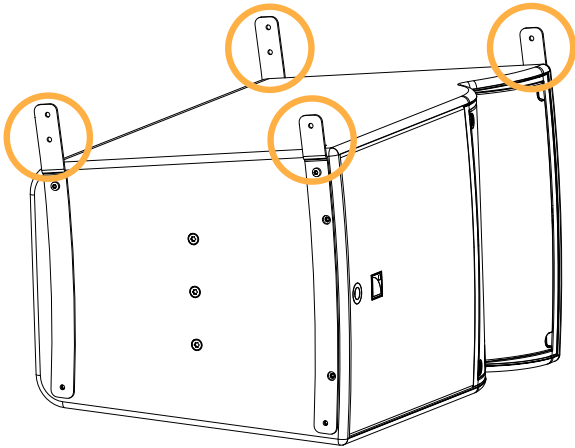

- After securing an enclosure to another enclosure, tighten all the screws on the supporting enclosure.

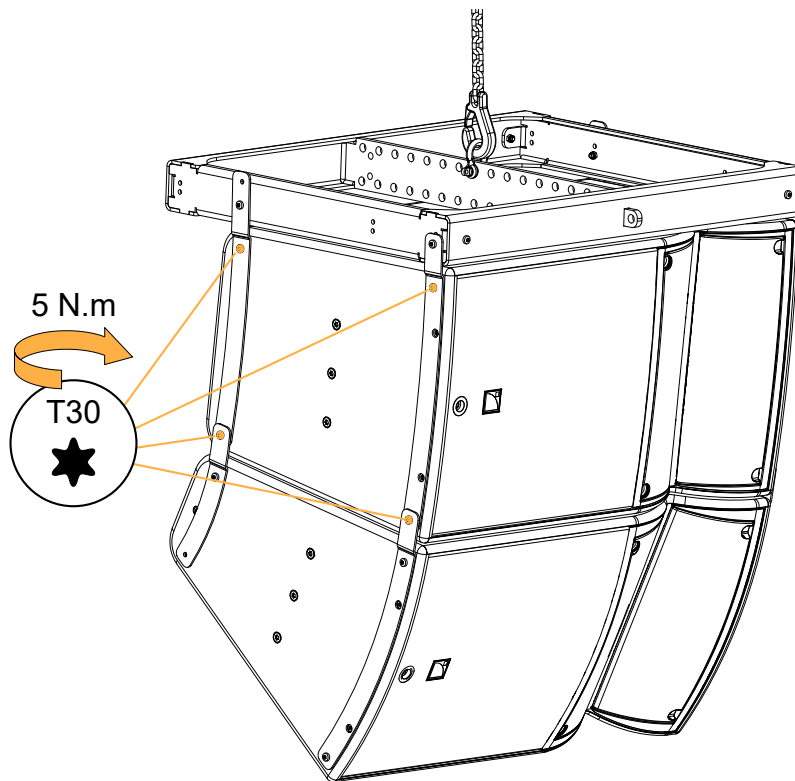

- In an A15i Wide/Focus array, make sure that the fins are on the same side. Additionally, in a KS21i / A15i Wide/Focus mixed array, make sure that the fins of A15i Wide/Focus are on the same side as the vents of KS21i.

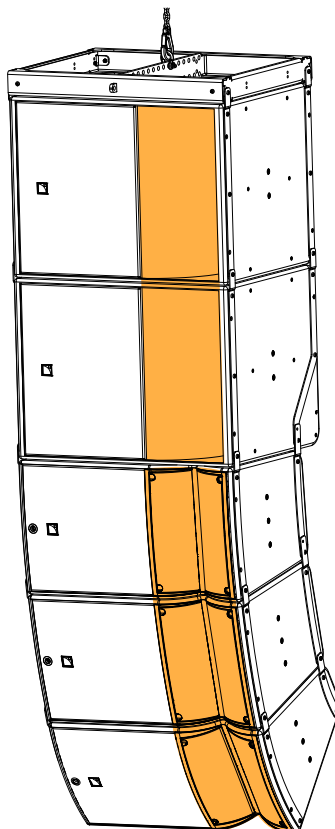

Screws

- Always remove the relevant placeholder screws before securing the rigging plates.

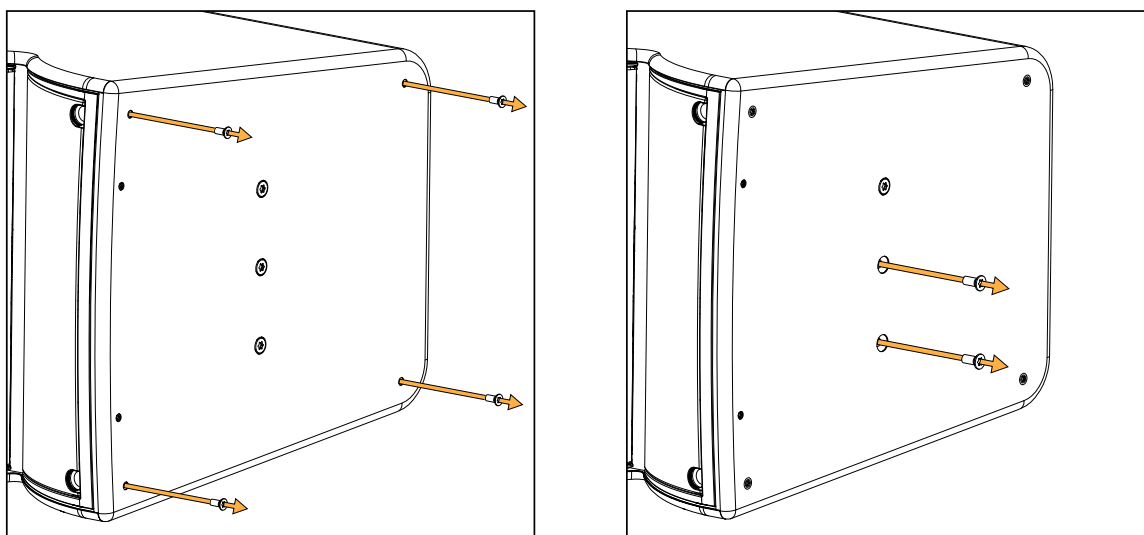

- Do not use placeholder screws for rigging purposes.

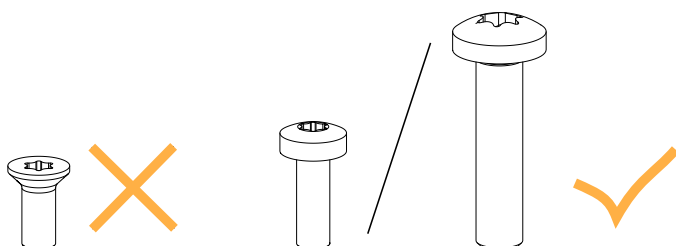

Stacked configurations



Fastening brackets

Always secure a stacked array to the ground using Ai-FIXBRACKET / A15i-TILTBRACKET to ensure stability of the array.

Tools

Before performing rigging procedures on this product, make sure all the tools listed are available. References are given for FACOM® products in this table. Other manufacturers can be used.

Name	Reference	Distributor
Set of 6-point 1/4" sockets	RL.NANO1 / R.360NANO	FACOM
electric screwdriver with torque selector	-	-
Torque screwdriver (2 - 10 N.m)	A.404	FACOM
10 mm wrench	-	-

Flying

Flying a vertical array with A15i-BUMP

Type of deployment	flown array
Rigging accessories	A15i-BUMP A15i Wide/Focus / KS21i rigging plates 2 x Ø12 mm shackle WLL 1 t (provided) M-BARi (optional) A15i-TILT (optional)
Additional accessories	M6x18 rigging screws (provided) M6 nuts (provided) T30 Torx bit
Min number of operators	3

Rigging plates

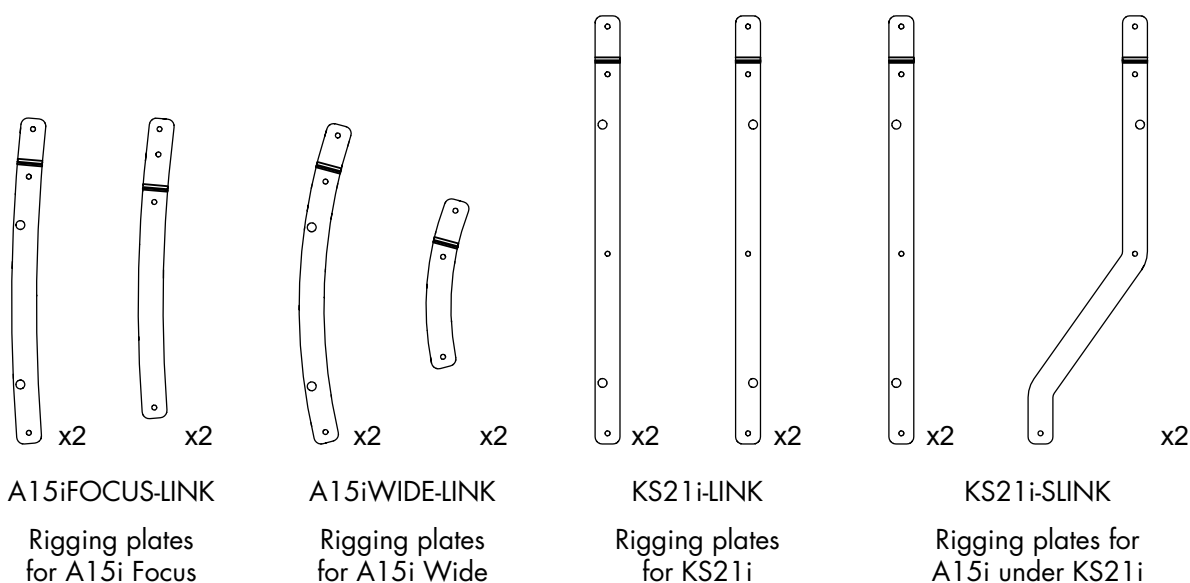

- ⚠ Risk of falling objects**
Verify that no unattached items remain on the product or assembly.
- ⚠ Secondary safety**
Use available holes on the rigging accessories to implement a secondary safety.
- ⚠ Flying hybrid arrays**
The KS21i subwoofers must always be on top of the array.
Refer to Soundvision for maximum configurations.
- ⚠ Array orientation**
Under A15i-BUMP, the enclosure HF section can be oriented both ways.
Under KS21i, the HF section is on the same side as the subwoofer vent.

A15i Wide/Focus array

Procedure

1. Prepare the A15i Wide/Focus enclosures by removing the placeholder screws and securing rigging plates on both sides.

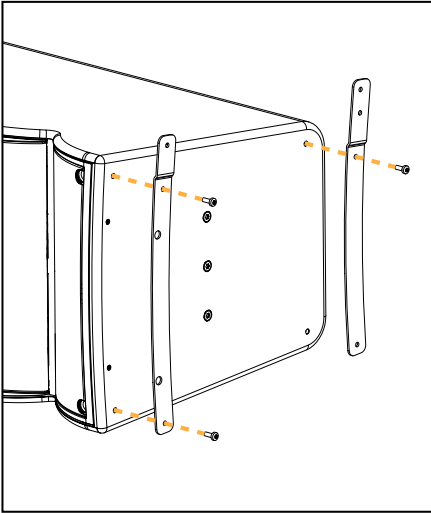

2. Secure A15i-BUMP on top of A15i Wide/Focus.



Optionally, secure an M-BARi on A15i-BUMP to extend the site angle capability. Use the provided rigging axes.

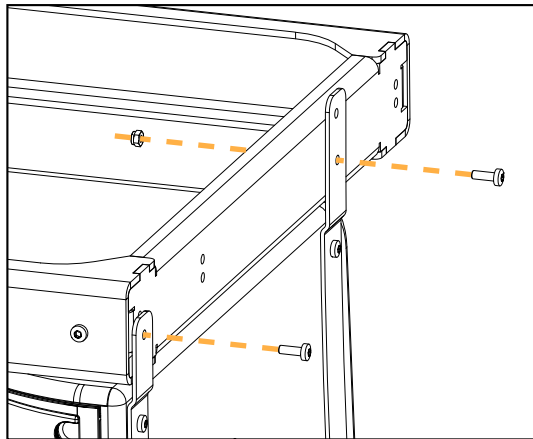
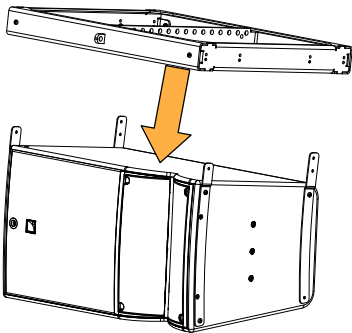
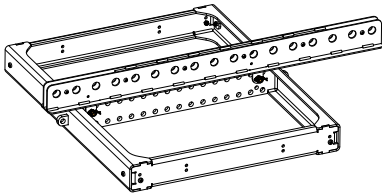

3. Select the pick-up point and raise the array.

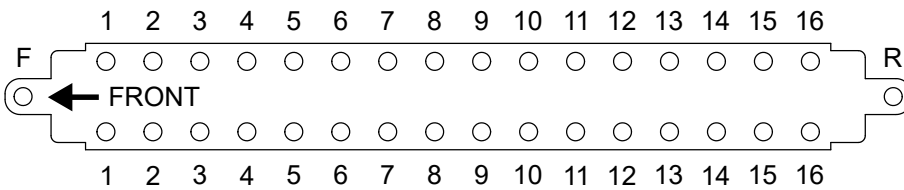

4. Secure the additional A15i Wide/Focus under the array:

- a)  **This step requires three operators.**
Hold the enclosure at the bottom until the rigging plates are secured.

Lift the rear of the new A15i Wide/Focus and secure it to the array by pre-tightening a rigging screw on both sides.

-  **A15i Focus site angle adjustment**
A15iFOCUS-LINK can be used to add an inter-element angle of 5° between two A15i Focus.

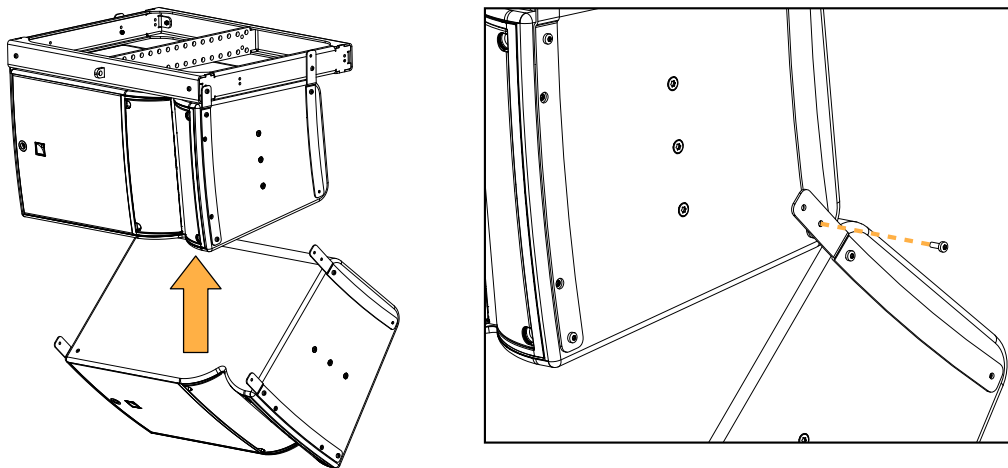

- b) Remove the rigging screws at the bottom front on both sides of the supporting enclosure.

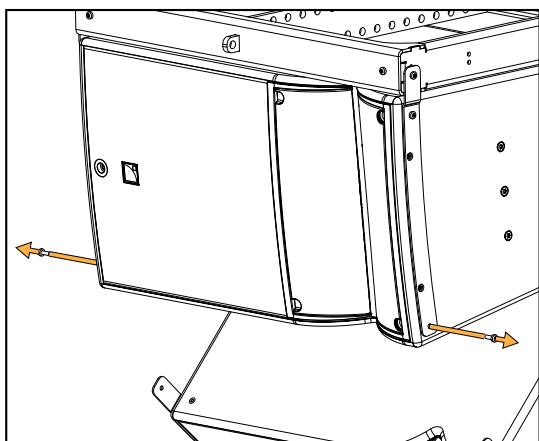

- c) Link the enclosures at the front with rigging screws.

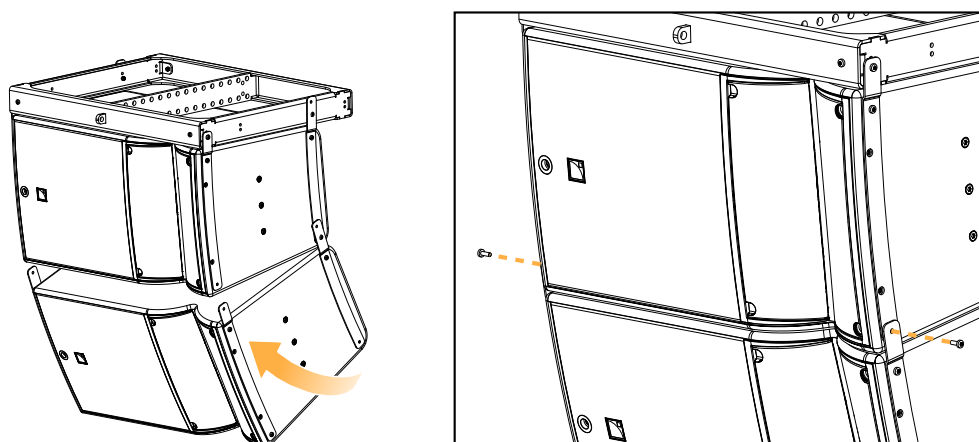

- d) Tighten all the screws on the supporting enclosure.
Apply a torque of 5 N.m.

e) Repeat the procedure until the A15i Wide/Focus array is completed.

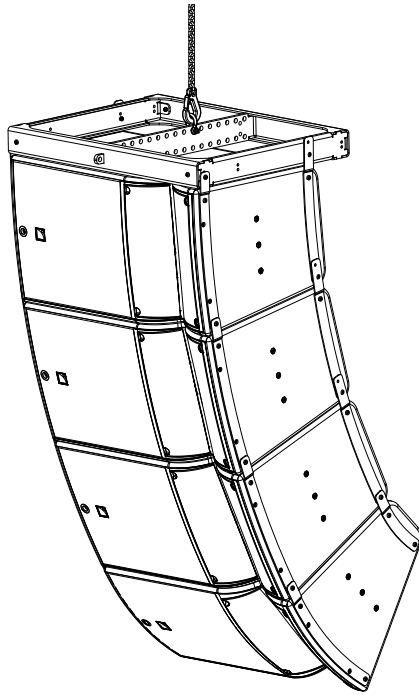

5. Check that all the screws are secured and tightened (5 N.m torque) and raise the array.

What to do next

[Securing a screen](#) (p.104)

KS21i and A15i Wide/Focus array

Procedure

1. Prepare the enclosures by removing the placeholder screws and securing rigging plates on both sides.

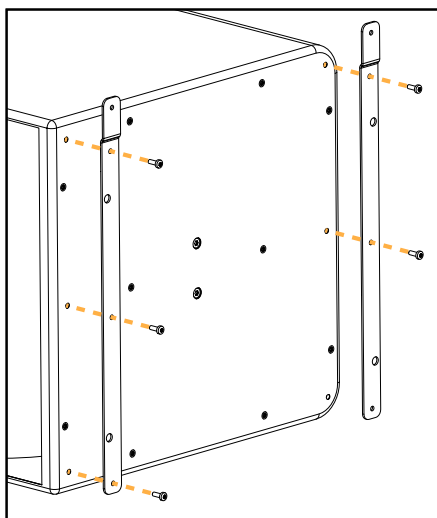

KS21i

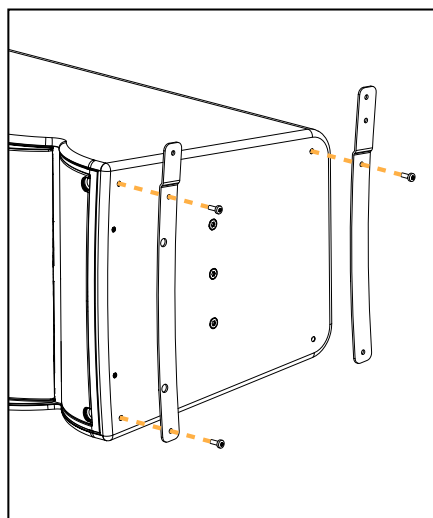

A15i Wide/Focus



Linking KS21i to A15i Wide/Focus

Use KS21i-SLINK instead of KS21i-LINK for the last KS21i in a KS21i / A15i Wide/Focus hybrid array.

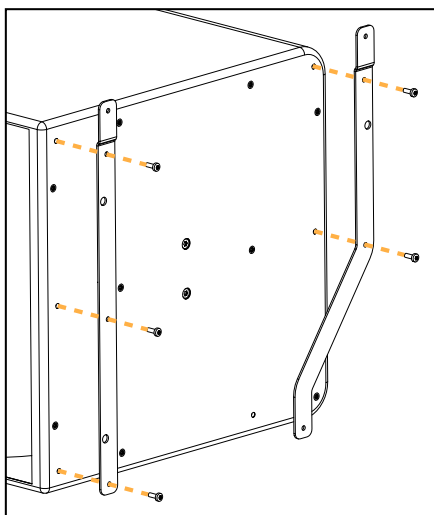

2. Secure A15i-BUMP on top of KS21i.

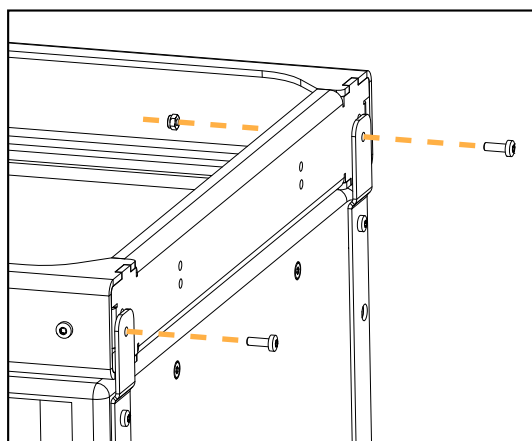
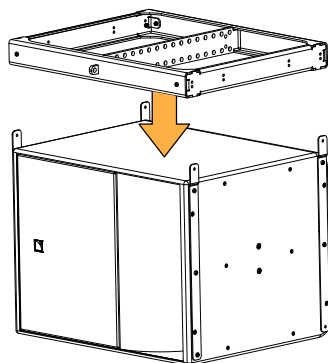

3. Select the pick-up point and raise the array.

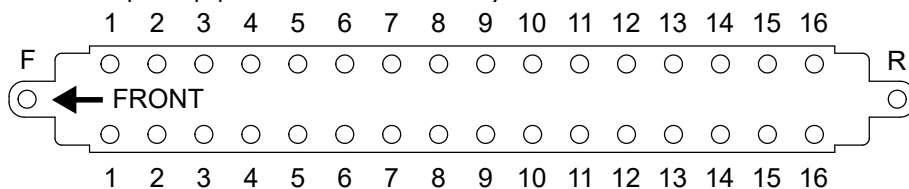

4. Secure an additional KS21i under the array:

a) **! This step requires three operators.**

Hold the enclosure at the bottom until the rigging plates are secured.

Lift the rear of the new KS21i and secure it to the array by pre-tightening a rigging screw on both sides.

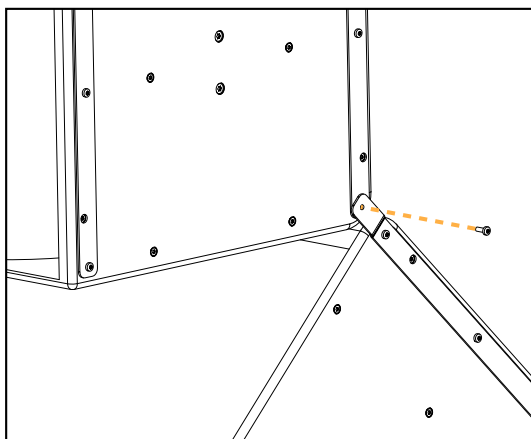
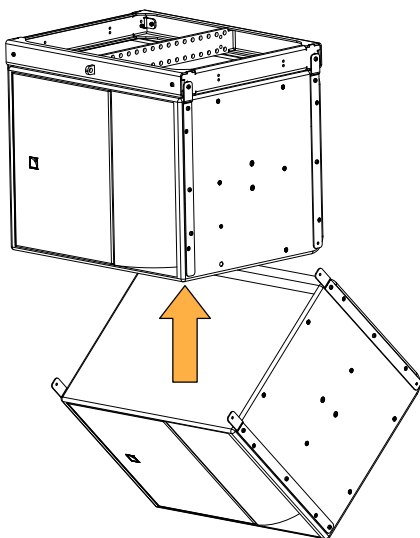

b) Remove the rigging screws at the bottom front on both sides of the supporting KS21i.

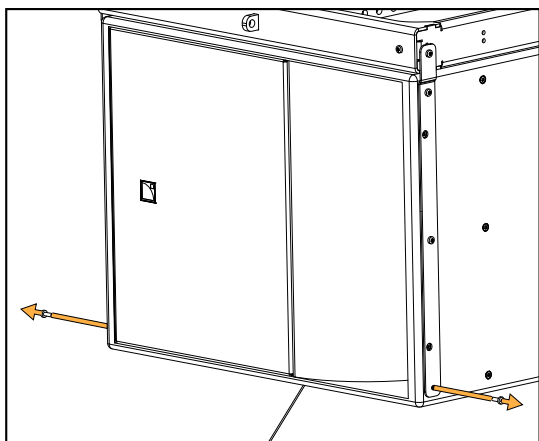

c) Link the KS21i enclosures at the front with rigging screws.

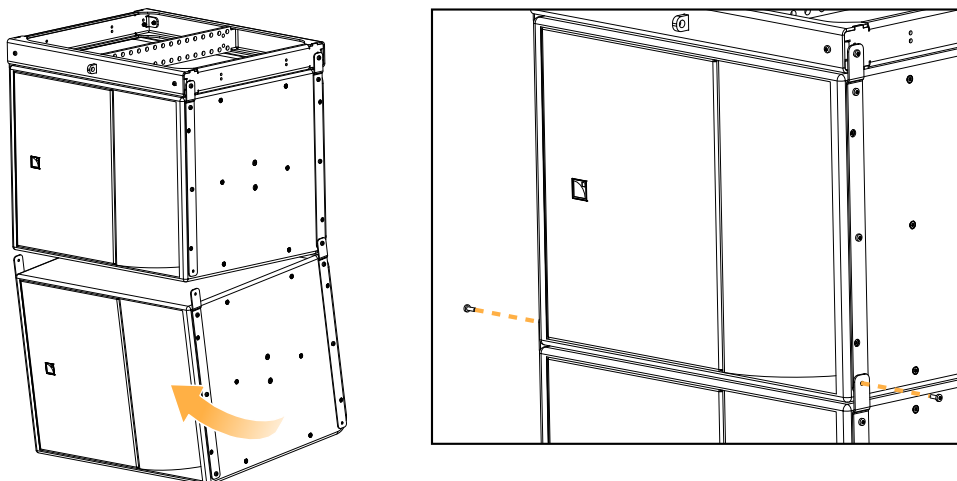

d) Tighten all the screws on the supporting KS21i.

Apply a torque of 5 N.m.

e) Repeat the procedure until the KS21i array is completed.

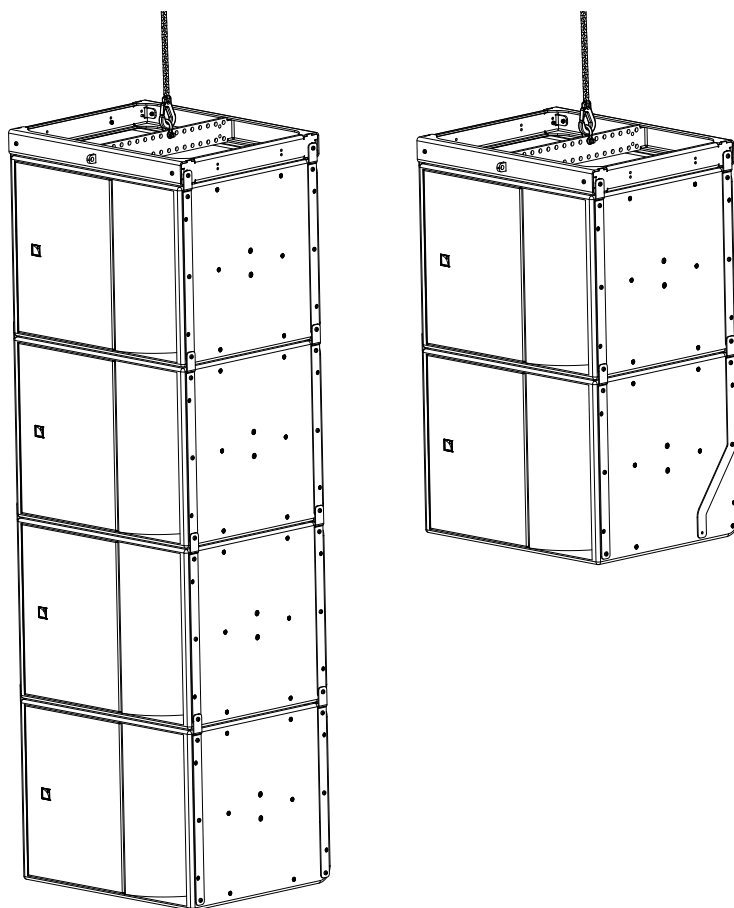

5. For a KS21i / A15i Wide/Focus hybrid array, secure additional A15i Wide/Focus (refer to [A15i Wide/Focus array](#) (p.64), from step 4 (p.65)).

For a hybrid array using A15i-TILT, refer to [KS21i / A15i Wide/Focus array with A15i-TILT](#) (p.71).

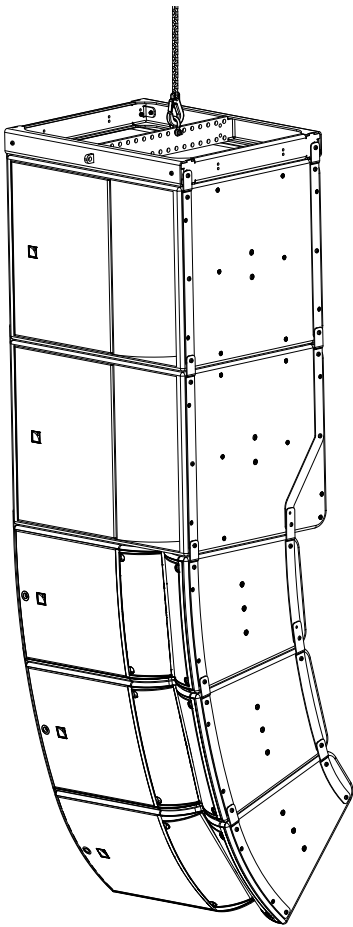

6. Check that all the screws are secured and tightened (5 N.m torque) and raise the array.

What to do next

[Securing a screen](#) (p.104)

KS21i / A15i Wide/Focus array with A15i-TILT

Procedure

1. Prepare a KS21i array as described in [KS21i and A15i Wide/Focus array](#) (p.67).

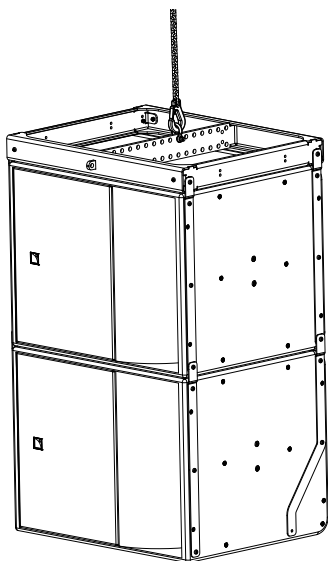

2. Secure A15i-TILT at the bottom of the array.

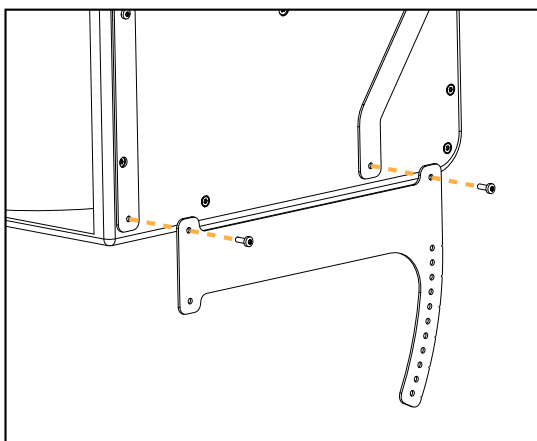

3. Prepare the first A15i Wide/Focus by removing the placeholder screws and securing end rigging plates on both sides.

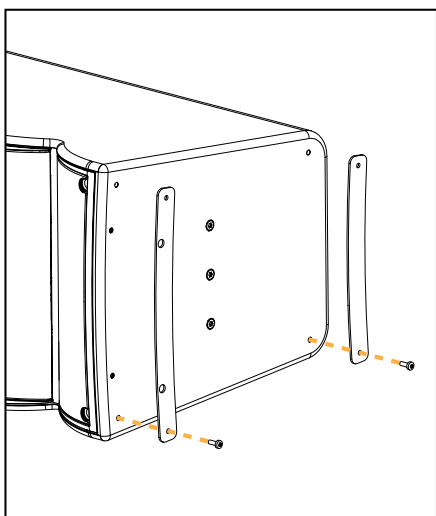

- 4.** Secure the first A15i Wide/Focus to A15i-TILT:
a) Secure the front of the enclosure to A15i-TILT.

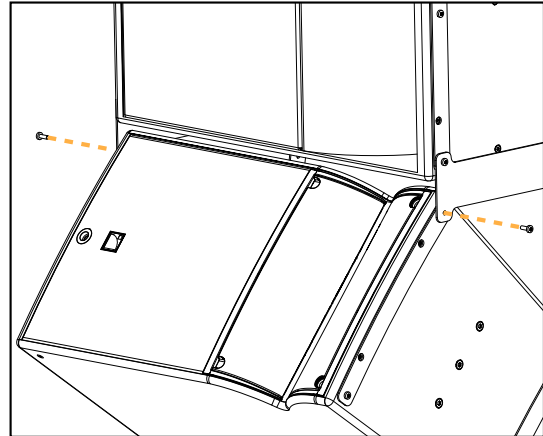
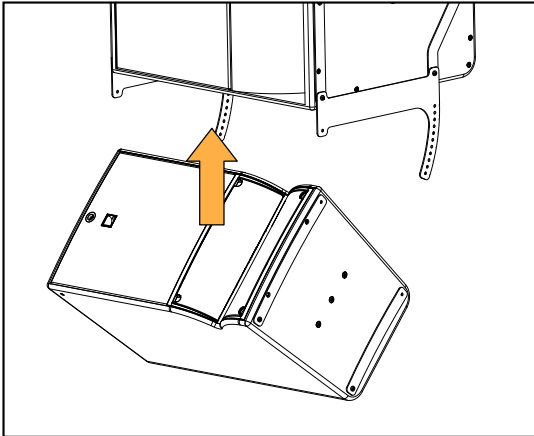

- b) Lift the rear of the enclosure and secure it to A15i-TILT at the desired angle.

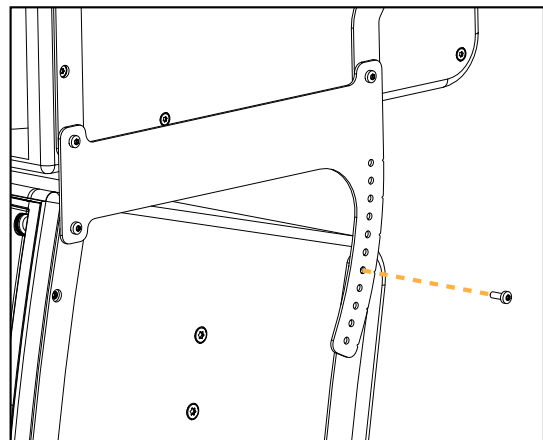
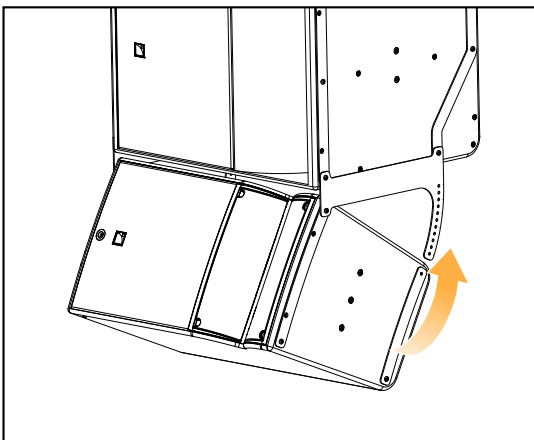

- 5.** Prepare additional A15i Wide/Focus by removing the placeholder screws and securing rigging plates on both sides.

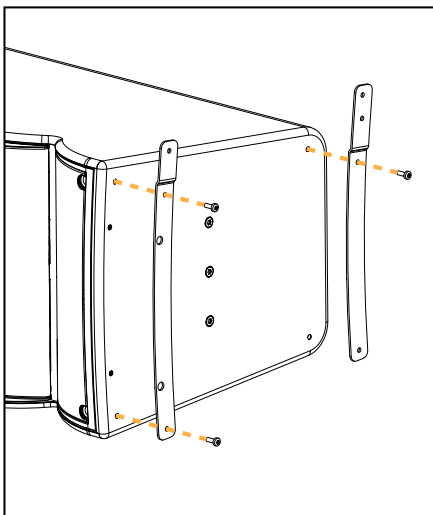

6. Secure the additional A15i Wide/Focus under the array:

- a) Remove the rigging screws at the bottom rear on both sides of the supporting A15i Wide/Focus.

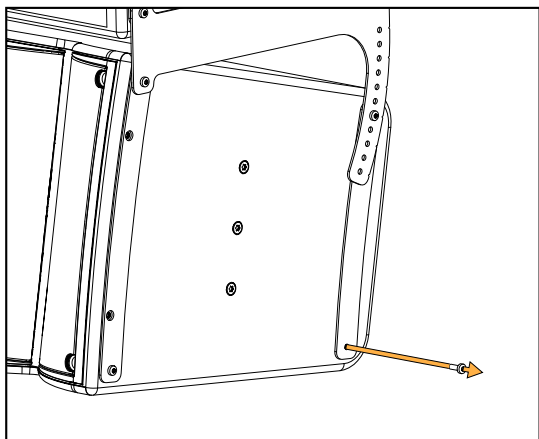

b) **!** **This step requires three operators.**

Hold the enclosure at the bottom until the rigging plates are secured.

Lift the rear of the new A15i Wide/Focus and secure it to the array by pre-tightening a rigging screw on both sides.



A15i Focus site angle adjustment

A15iFOCUS-LINK can be used to add an inter-element angle of 5° between two A15i Focus.

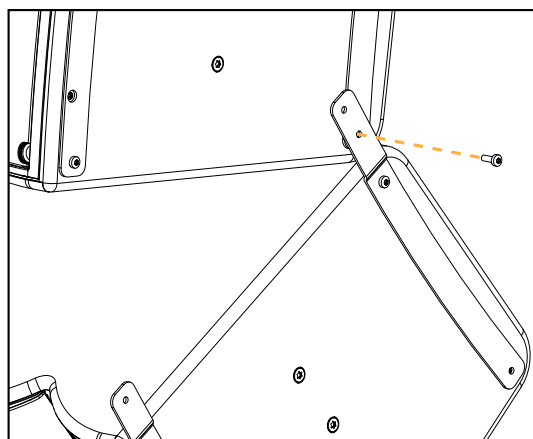
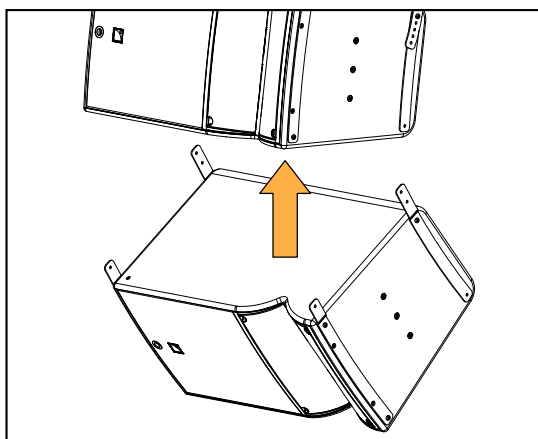

- c) Remove the rigging screws at the bottom front on both sides of the top A15i Wide/Focus.

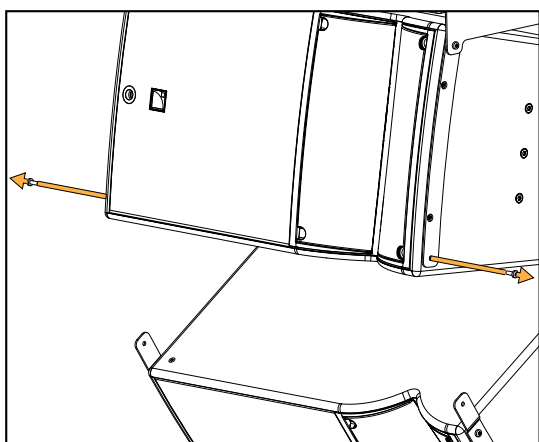

d) Link the A15i Wide/Focus enclosures at the front with rigging screws.

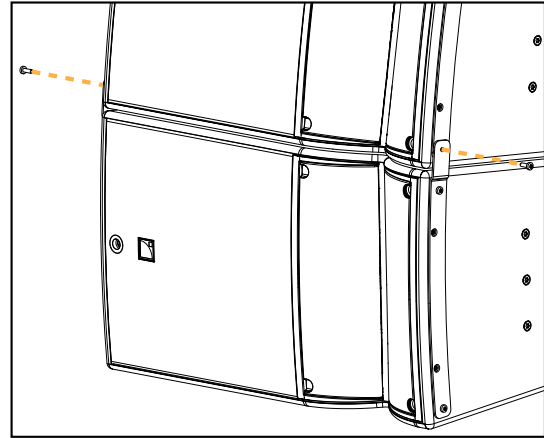
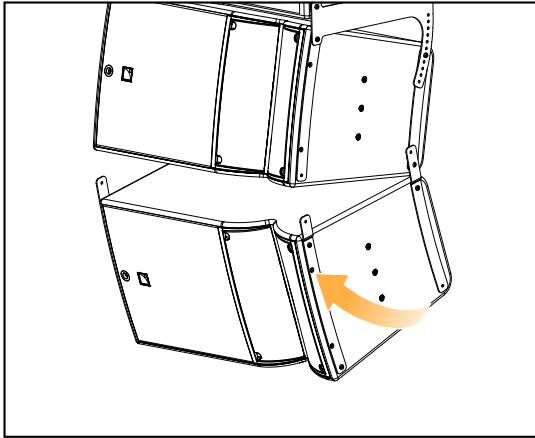

e) Tighten all the screws on the supporting A15i Wide/Focus.

Apply a torque of 5 N.m.

f) Repeat the procedure until the A15i Wide/Focus array is completed.

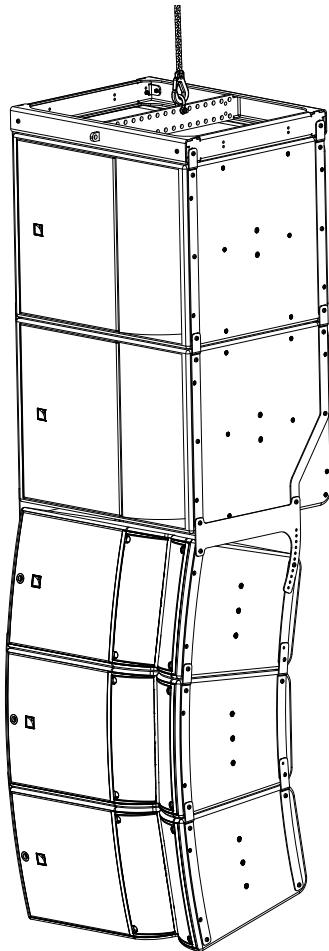

7. Check that all the screws are secured and tightened (5 N.m torque) and raise the array.

What to do next

[Securing a screen \(p.104\)](#)

Flying a vertical array with A15i-RIGBAR

Type of deployment	flown array
Rigging accessories	A15i-RIGBAR A15i Wide/Focus / KS21i rigging plates 2 x Ø12 mm shackle WLL 1 t (provided)
Additional accessories	M6x18 rigging screws (provided) T30 Torx bit
Min number of operators	3

Rigging plates

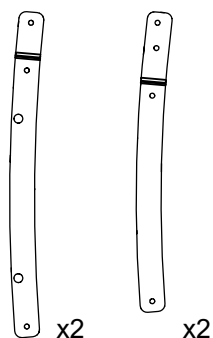

A15i FOCUS-LINK
Rigging plates
for A15i Focus

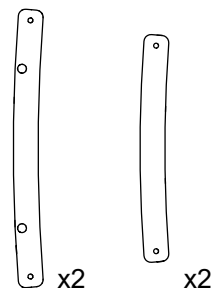

A15i FOCUS-ENDLINK
End rigging plates
for A15i Focus

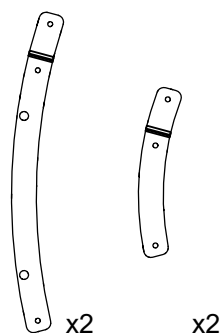

A15i WIDE-LINK
Rigging plates
for A15i Wide

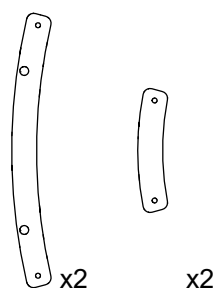

A15i WIDE-ENDLINK
End rigging plates
for A15i Wide

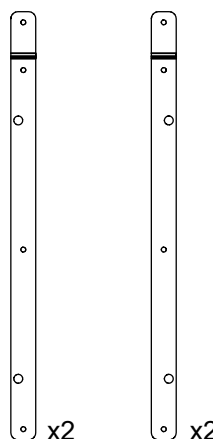

KS21i-LINK
Rigging plates
for KS21i

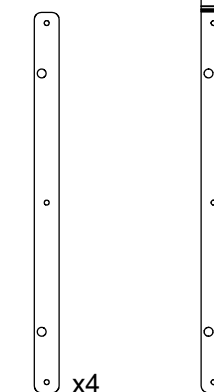

KS21i-ENDLINK
End rigging
plates for
KS21i

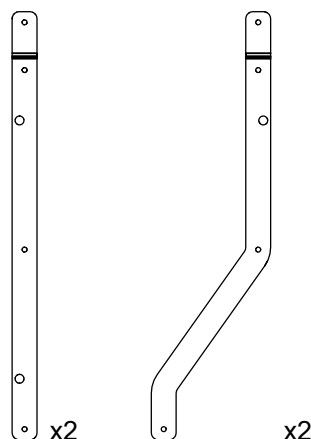

KS21i-SLINK
Rigging plates for
A15i under KS21i

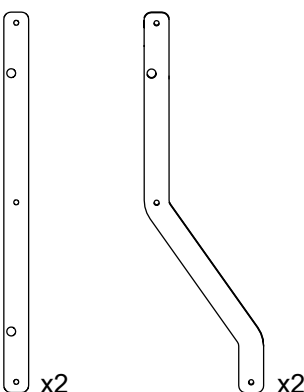

KS21i-ENDSLINK
End rigging plates for
A15i under KS21i



Risk of falling objects

Verify that no unattached items remain on the product or assembly.



Secondary safety

Use available holes on the rigging accessories to implement a secondary safety.



Flying hybrid arrays

The KS21i subwoofers must always be on top of the array.
Refer to Soundvision for maximum configurations.

Assembly

Procedure

1. Prepare the first enclosure by removing the placeholder screws and securing rigging plates on both sides.

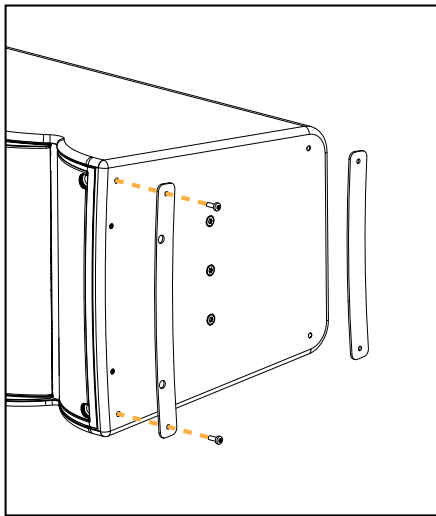

A15i Wide/Focus

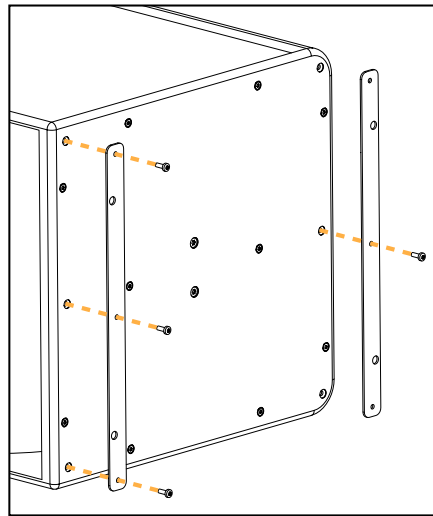

KS21i

2. Secure A15i-RIGBAR at the rear of the enclosure.



Secure A15i-RIGBAR at the front for a positive initial site angle.

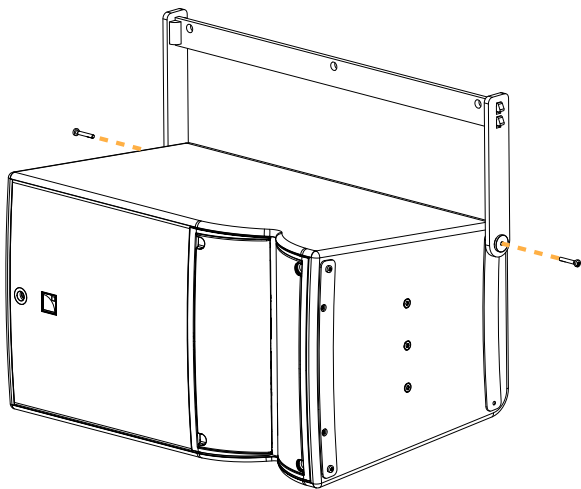

A15i Wide/Focus

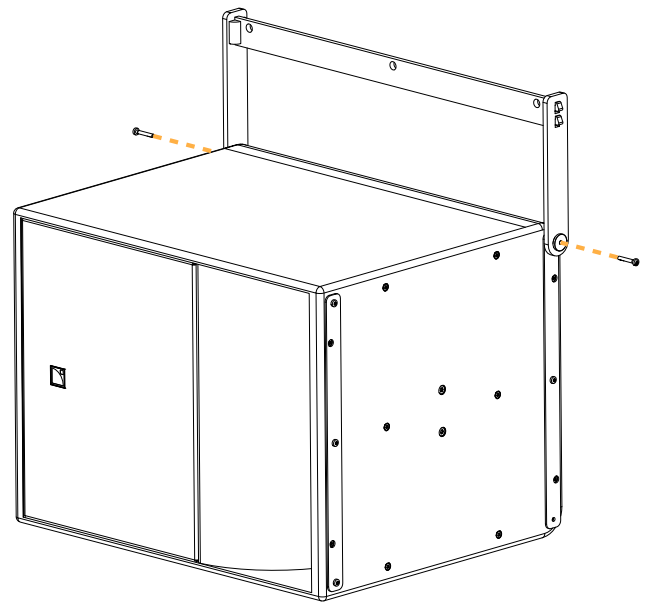

KS21i

3. Select the pick-up point and raise the array.
4. Follow the relevant procedure in [Flying a vertical array with A15i-BUMP](#) (p.63) from step 4 to the end.

What to do next

[Adding a pullback with A15i-RIGBAR](#) (p.77)

Adding a pullback with A15i-RIGBAR

Type of deployment	flown array with pullback
Rigging accessories	A15i-RIGBAR 1 x Ø12 mm shackle WLL 1 t (provided)
Additional accessories	M6x40 screws (provided) M6x18 rigging screws (provided) T30 Torx bit
Min number of operators	1

⚠ Risk of falling objects
Verify that no unattached items remain on the product or assembly.

⚠ Secondary safety
Use available holes on the rigging accessories to implement a secondary safety.

Assembly

Procedure

1. Prepare a vertical array as described in [Flying a vertical array with A15i-BUMP](#) (p.63) or [Flying a vertical array with A15i-RIGBAR](#) (p.75).
2. Raise the array until the bottom enclosure is accessible.
3. Remove the bottom screw from the rear rigging plates on each side.

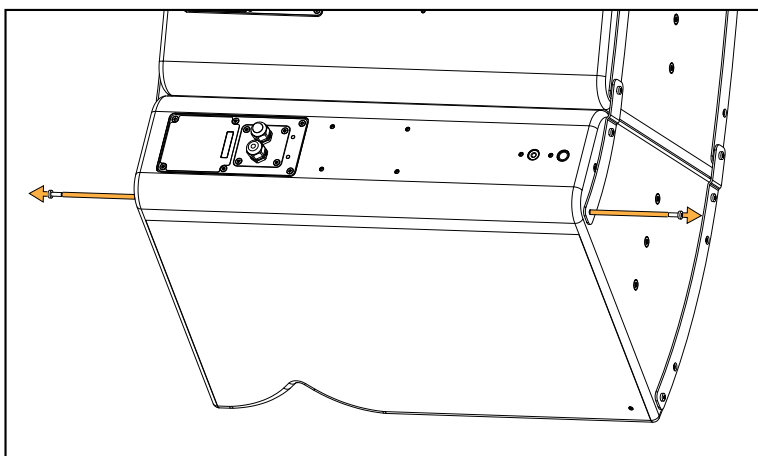

4. Secure A15i-RIGBAR at the rear of the enclosure with M6x40 Torx screws.
Apply a torque of 5 N.m.

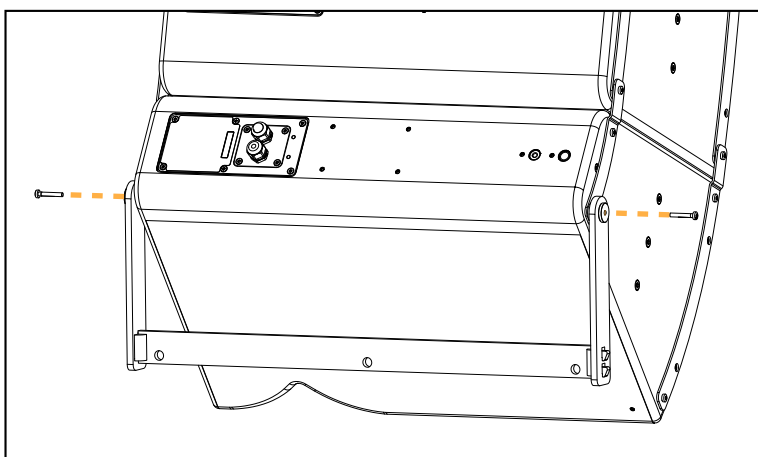

5. Secure a shackle to A15i-RIGBAR and lift it with an additional motor.

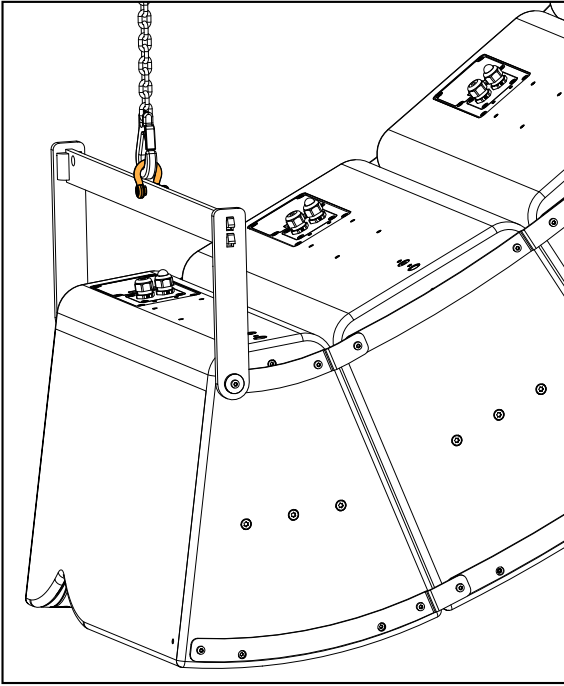

Flying a radial array with A15i-LIFT

Type of deployment	flown radial array
Rigging accessories	A15i Wide/Focus rigging plates one A15i-LIFT for three enclosures LA-SLING2T or a bridle (optional) Ø12 mm shackles WLL 1 t (provided)
Additional accessories	M6x18 rigging screws (provided) T30 Torx bit
Min number of operators	2

Rigging plates

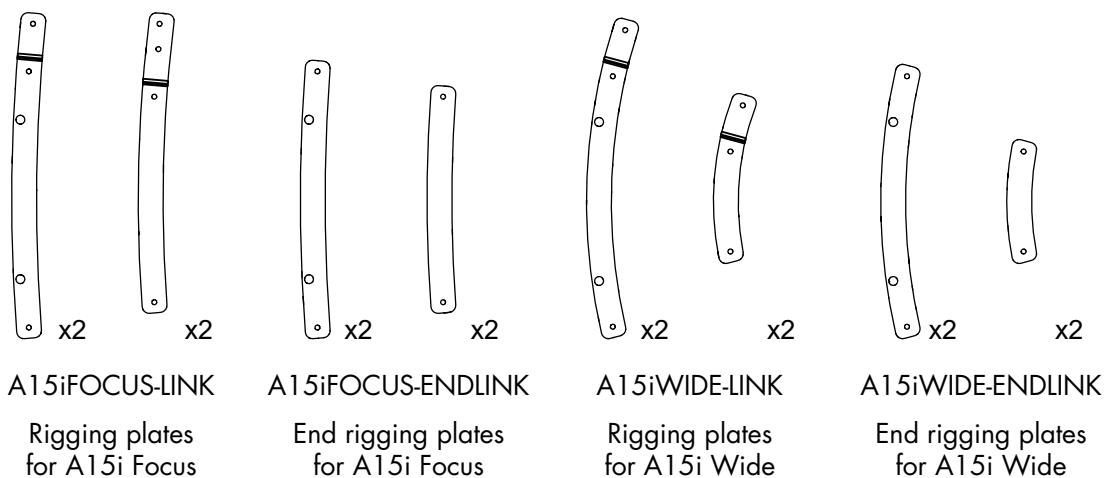

- ⚠ Risk of falling objects**
Verify that no unattached items remain on the product or assembly.
- ⚠ Additional safety with A15i-LIFT**
On each enclosure on which A15i-LIFT is secured, secure a DIN580 eye bolt to the dedicated insert to implement a secondary safety.
Use a shackle and a steel wire rope. Make sure the steel rope is as tensed as possible without bearing the load.

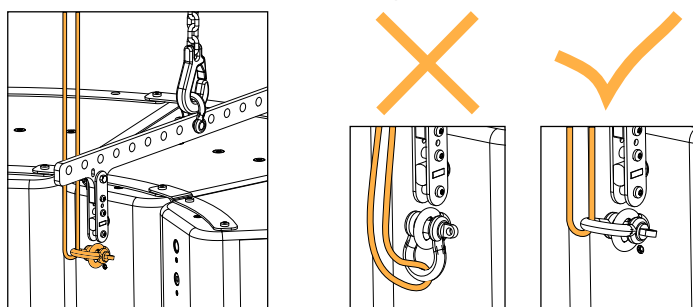

! A15i-LIFT quantity and position

Use one A15i-LIFT for up to three enclosures in the array.

Do not leave more than two adjacent enclosures unsupported.

Refer to [APPENDIX A: Authorized configurations with A15i-LIFT](#) (p.151).

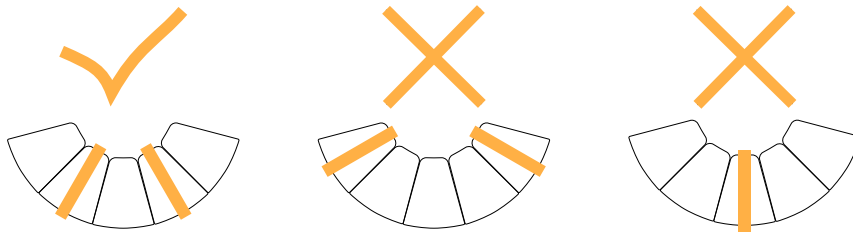

! Risk of tilting

When using a single motor or a bridle, make sure the array is symmetrical.

Assembly

Procedure

1. Place the enclosures (logo on top) at the lifting location.

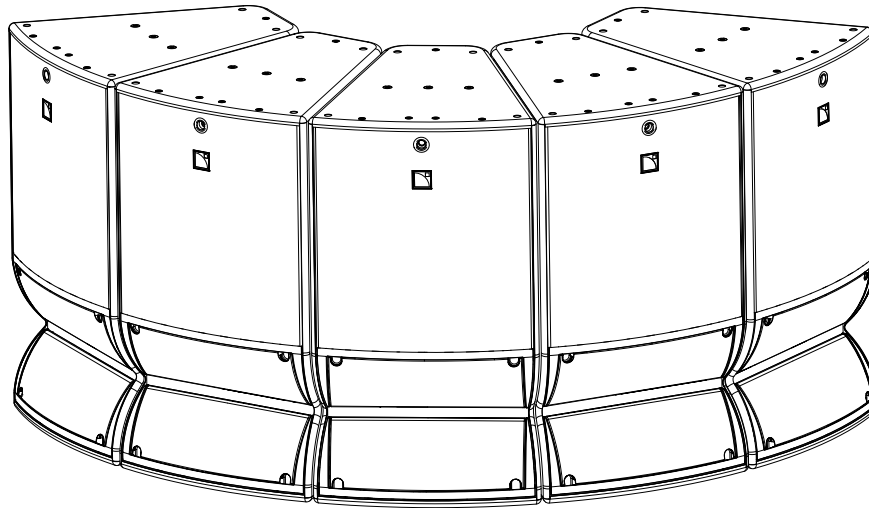

2. Remove the placeholder screws and connect the enclosures at the top using the rigging plates.



End links

Start by using end rigging plates on the leftmost or rightmost enclosure of the array, then proceed towards the other side.



Do not add inter-element angle with A15iFOCUS-LINK in radial configurations.



Do not tighten the screws until all rigging plates are secured.

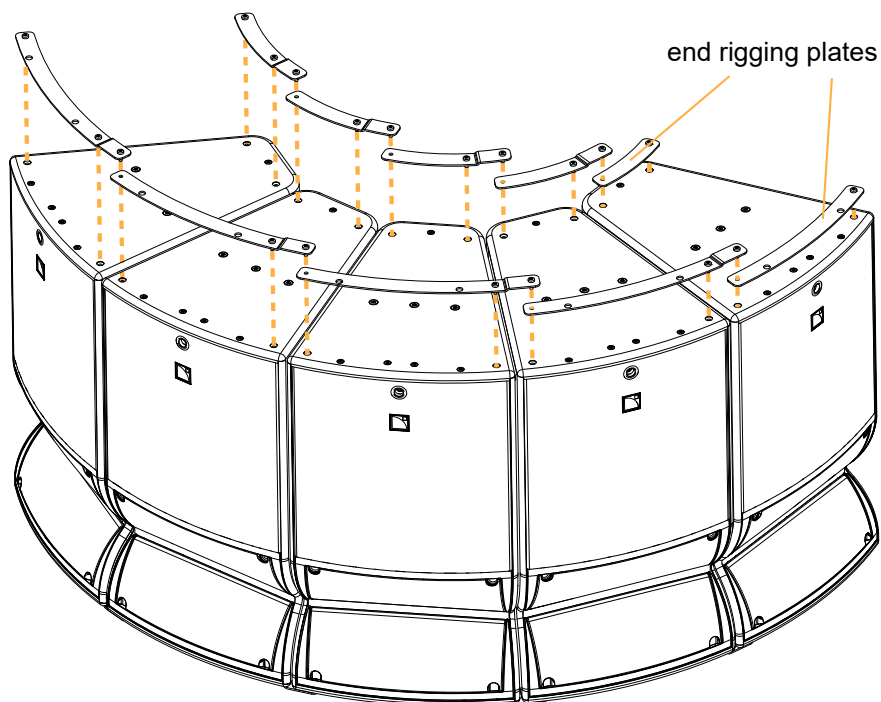

3. Tighten all the screws on the rigging plates.

Apply a torque of 5 N.m.

4. Secure the A15i-LIFT bars on the array.

a) Disconnect the rigging axis at the rear of A15i-LIFT.

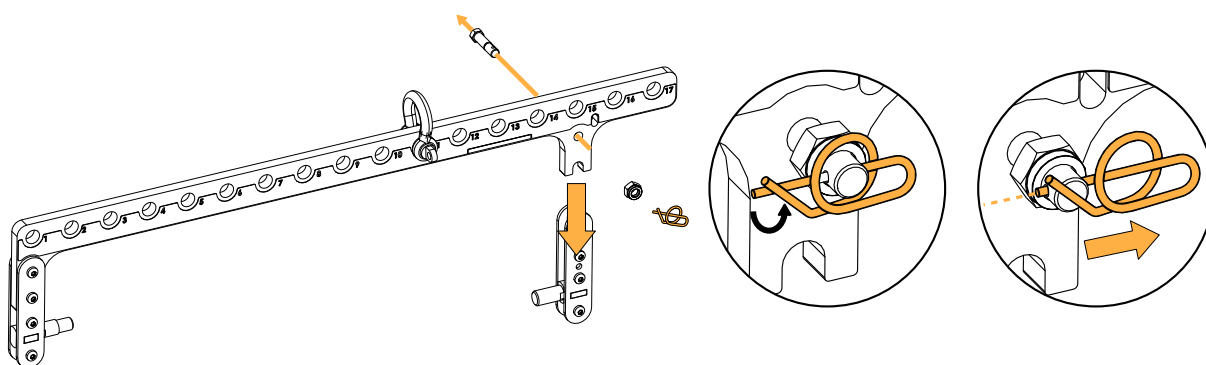

b) Insert the stub at the front of the enclosure.

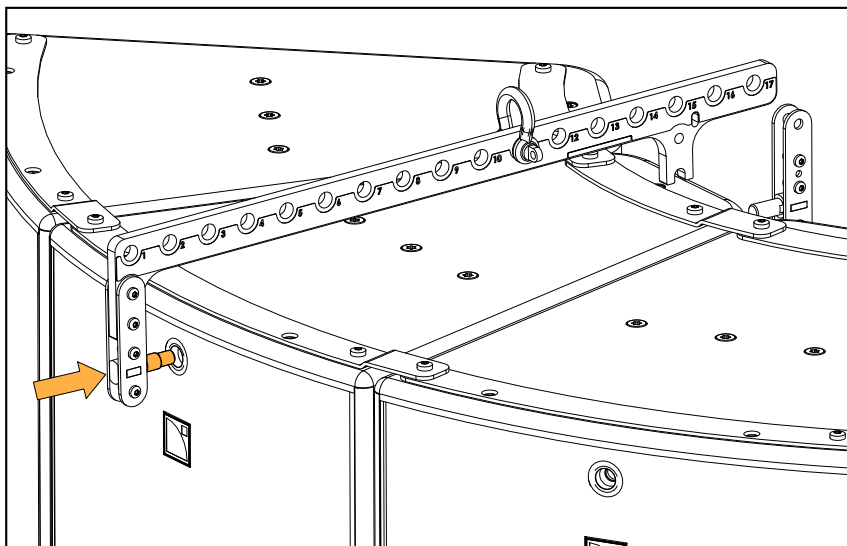

c) Insert the stub at the rear and secure the rigging axis.

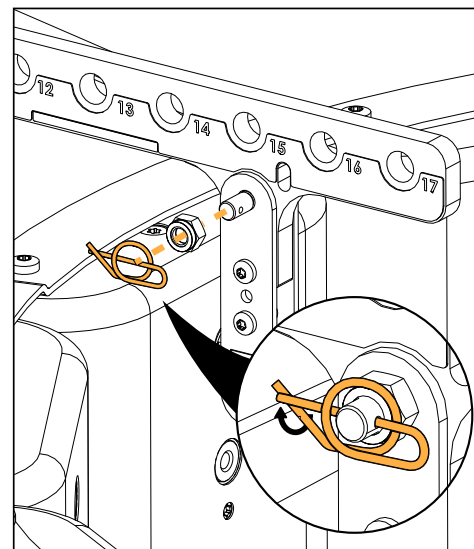
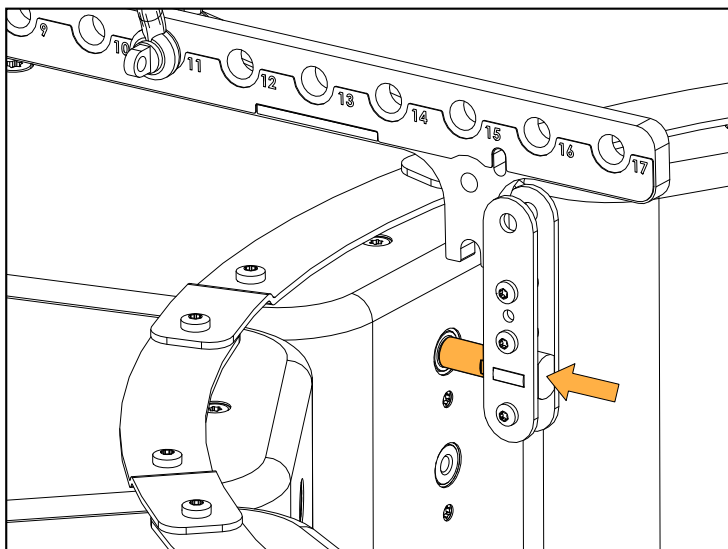

5. On each A15i-LIFT, secure a shackle to the desired pickup point.



A15i-LIFT pickup point

Select the same pickup point on each A15i-LIFT within an array of up to 6 enclosures.

For larger arrays, refer to [Radial arrays of 7 enclosures and more](#) (p.152).

6. Raise the array until the bottom of the array is easily accessible.

! For this operation, do not stand under the array.

7. Secure the enclosures at the bottom using the dedicated rigging plates.

! **End links**

Start by using end rigging plates on the leftmost or rightmost enclosure of the array, then proceed towards the other side.

! **Do not tighten the screws until all rigging plates are secured.**

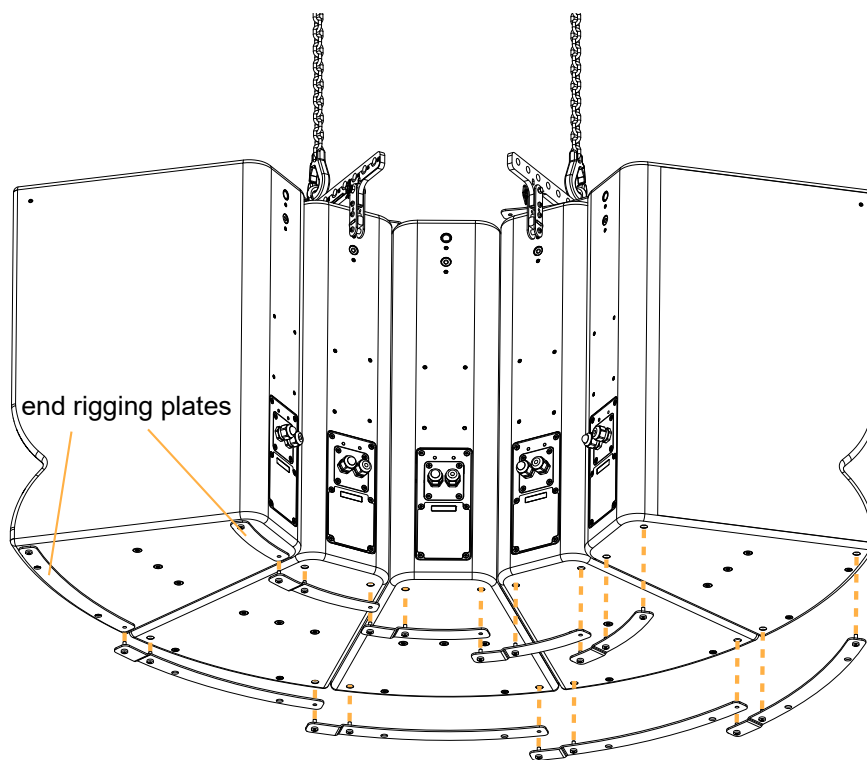

8. Tighten all the screws on the rigging plates (5 N.m torque).

What to do next

[Securing a screen](#) (p.104)

Wall-mounting or ceiling-mounting

Mounting an assembly with A-U15i

Type of deployment	ceiling-mounting, wall-mounting
Rigging accessories	A-U15i U-bracket rigging plates
Additional accessories	M8x35 rigging screws (provided) 4 x M10 screws and anchors T40 Torx bits
Min number of operators	3

Rigging plates

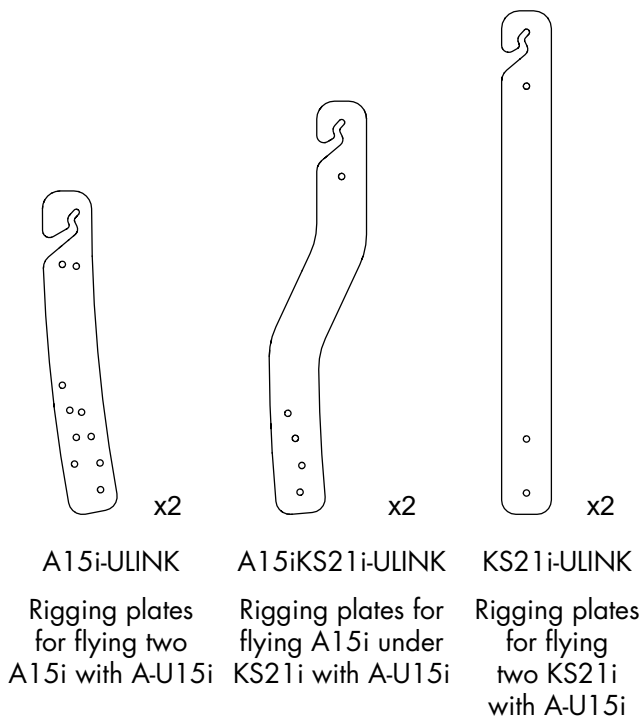

⚠ Additional safety for flown arrays
When flying an array, use available holes to implement a secondary safety.

⚠ The procedure is shown with A-U15i in horizontal position.
The same procedure applies for all configurations with A-U15i. Refer to [APPENDIX B: Configurations with A-U15i](#) (p.153).

Resistance value of anchoring points

Configuration		Tensile load	Shear load
Wall-mounted	A-U15i in horizontal position, with 1 enclosure	275 daN	65 daN
	A-U15i in horizontal position, with 2 enclosures	375 daN	75 daN
	A-U15i in vertical position, with 1 enclosure	40 daN	30 daN
Ceiling-mounted		150 daN	—

Assembly

Procedure



Fasteners for wall-mounting or ceiling-mounting

Select screw length and anchors applicable to the wall or ceiling properties.

1. Mount A-U15i on the ceiling or on the wall using four M10 screws.



When using a U-bracket horizontally, make sure the hooks are oriented upwards.

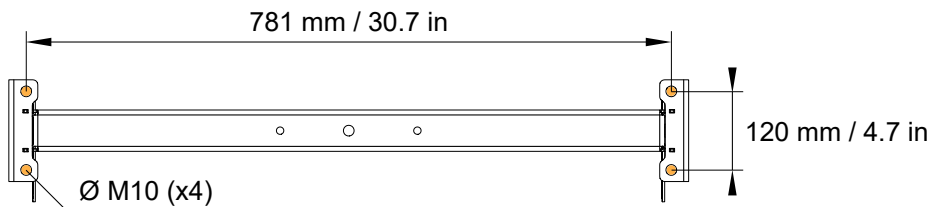

2. Remove the placeholder screws at the center of each side of the enclosure:

KS21i

Remove the two screws.

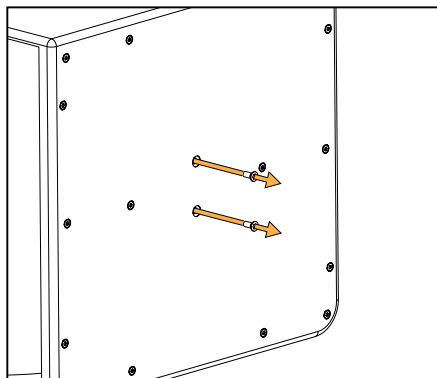

A15i Wide/Focus

Remove the central and top screws or the central and bottom screws, depending on the desired configuration (refer to [APPENDIX B: Configurations with A-U15i](#) (p.153)).

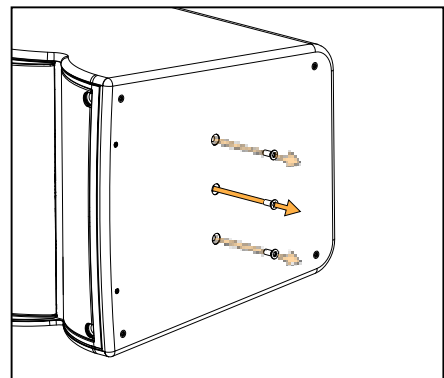

3. Using the screws provided with A-U15i, drive a screw on both sides. Approximately 10 mm (0.4 in) of the thread must be visible.

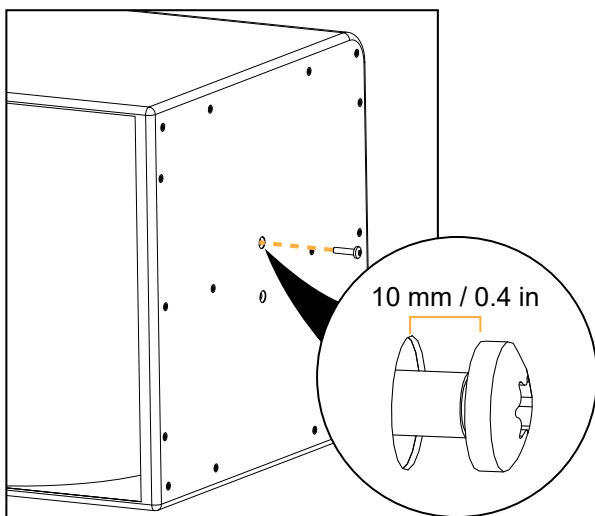

KS21i

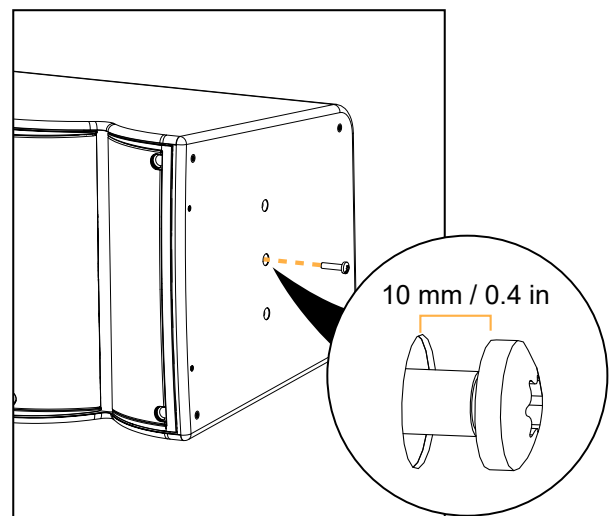

A15i Wide/Focus

Alternatively, drive the screw in the bottom insert for a configuration with the enclosure closer to the ceiling.

4. Mount the enclosure on A-U15i.



This step requires two operators.

Hold the enclosure at the bottom on each side.

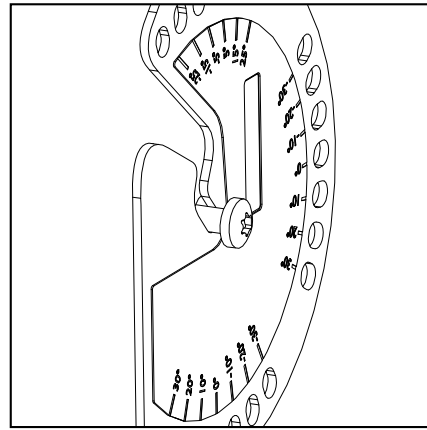
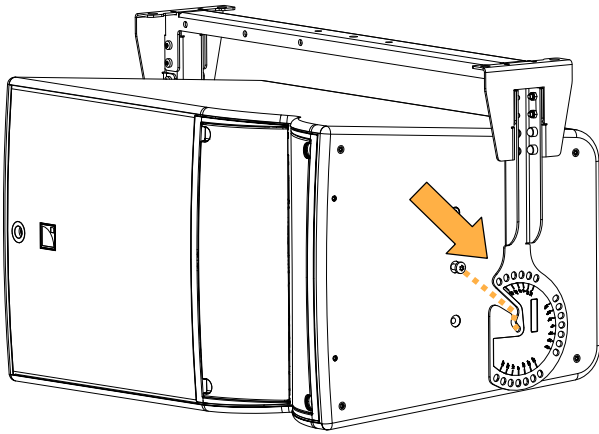

5. Set the angle:

For a single enclosure:

- a.** Rotate the enclosure to align the second insert with the selected site angle.

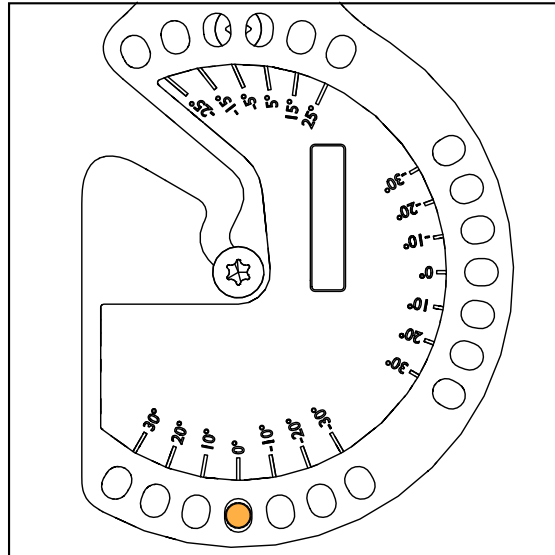
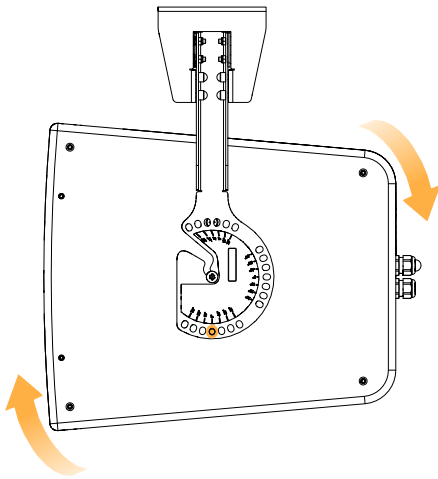

- b.** Drive a screw on both sides.

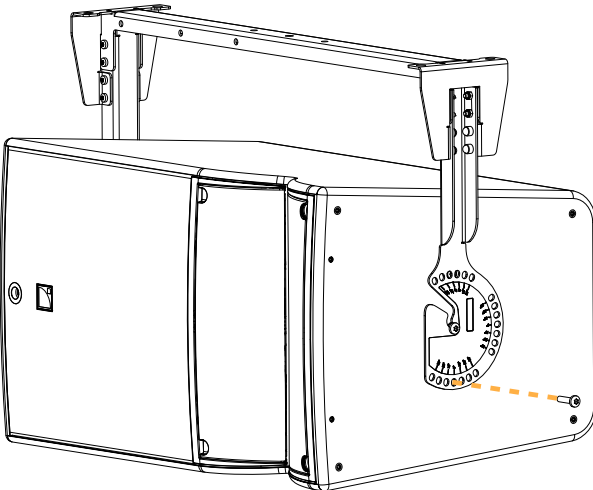

- c.** Tighten all the screws.
Apply a torque of 7 N.m.

For a two-enclosure assembly:

- !** This configuration limits the site angle. Refer to [APPENDIX B: Configurations with A-U15i](#) (p.153) for a list of possible site angles for each enclosure.

- a.** Slide the A15i-ULINK / A15iKS21i-ULINK / KS21i-ULINK rigging plates between A-U15i and the enclosure, with the hooks facing front.

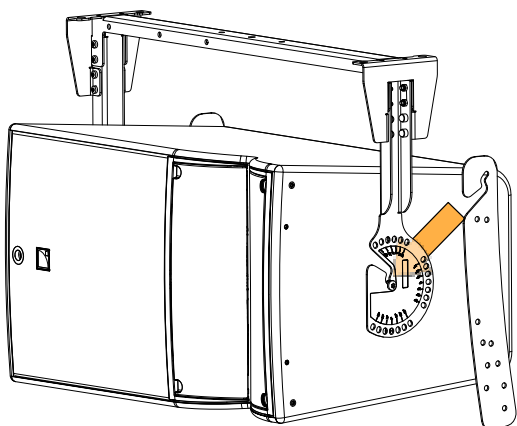

- b.** Rotate the enclosure and the rigging plates to align the second insert and the rigging plates with the selected site angle.

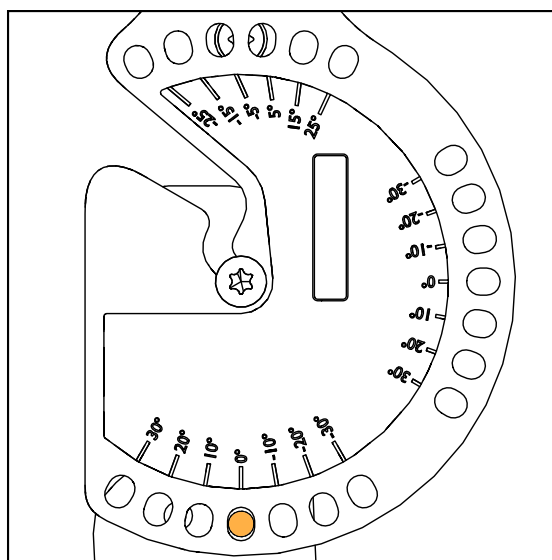
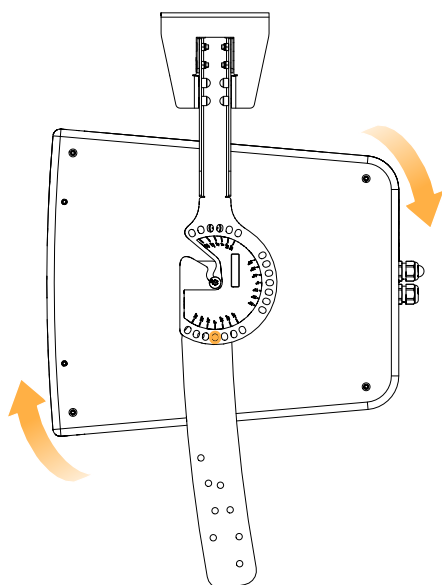

For a an array of two A15i Wide/Focus, make sure to use the correct hole on A15i-ULINK.

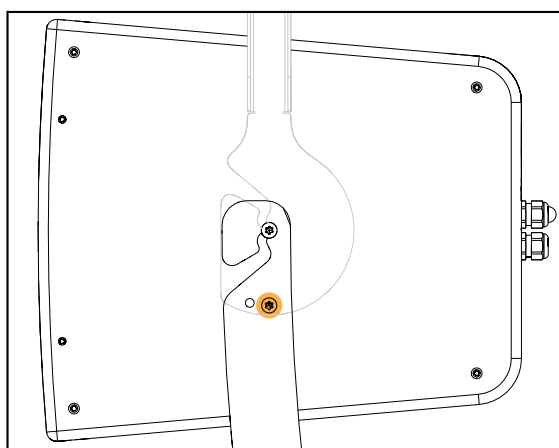

A15i Wide/Focus under A15i Focus

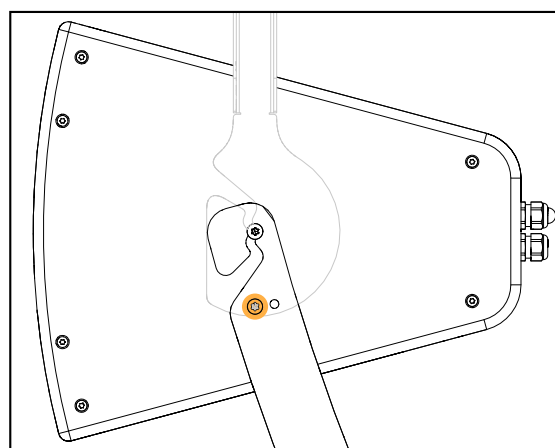

A15i Wide/Focus under A15i Wide

- c. Drive a screw on both sides.

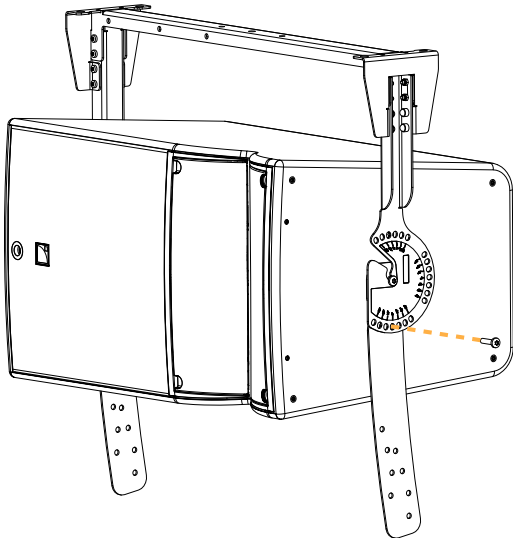

- d. Tighten all the screws.
Apply a torque of 7 N.m.

- 6. Prepare a new enclosure.

KS21i

Remove the two placeholder screws at the center of each side of the enclosure.

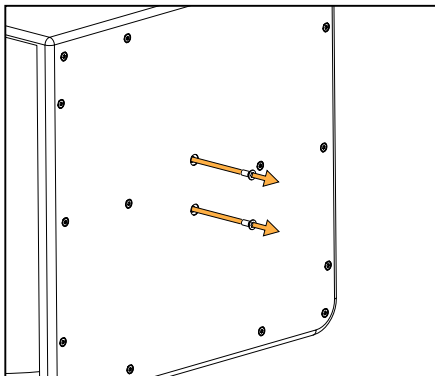

A15i Wide/Focus

Remove the central and top placeholder screws at the center of each side of the enclosure.

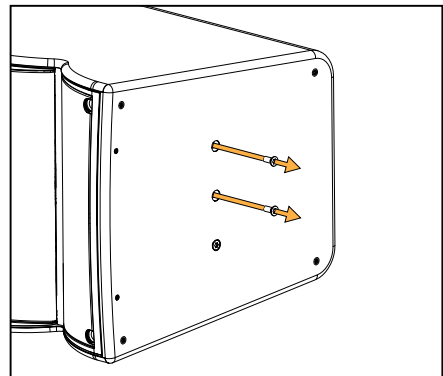

7. Secure the enclosure to the U-bracket rigging plates.

Apply a torque of 7 N.m.

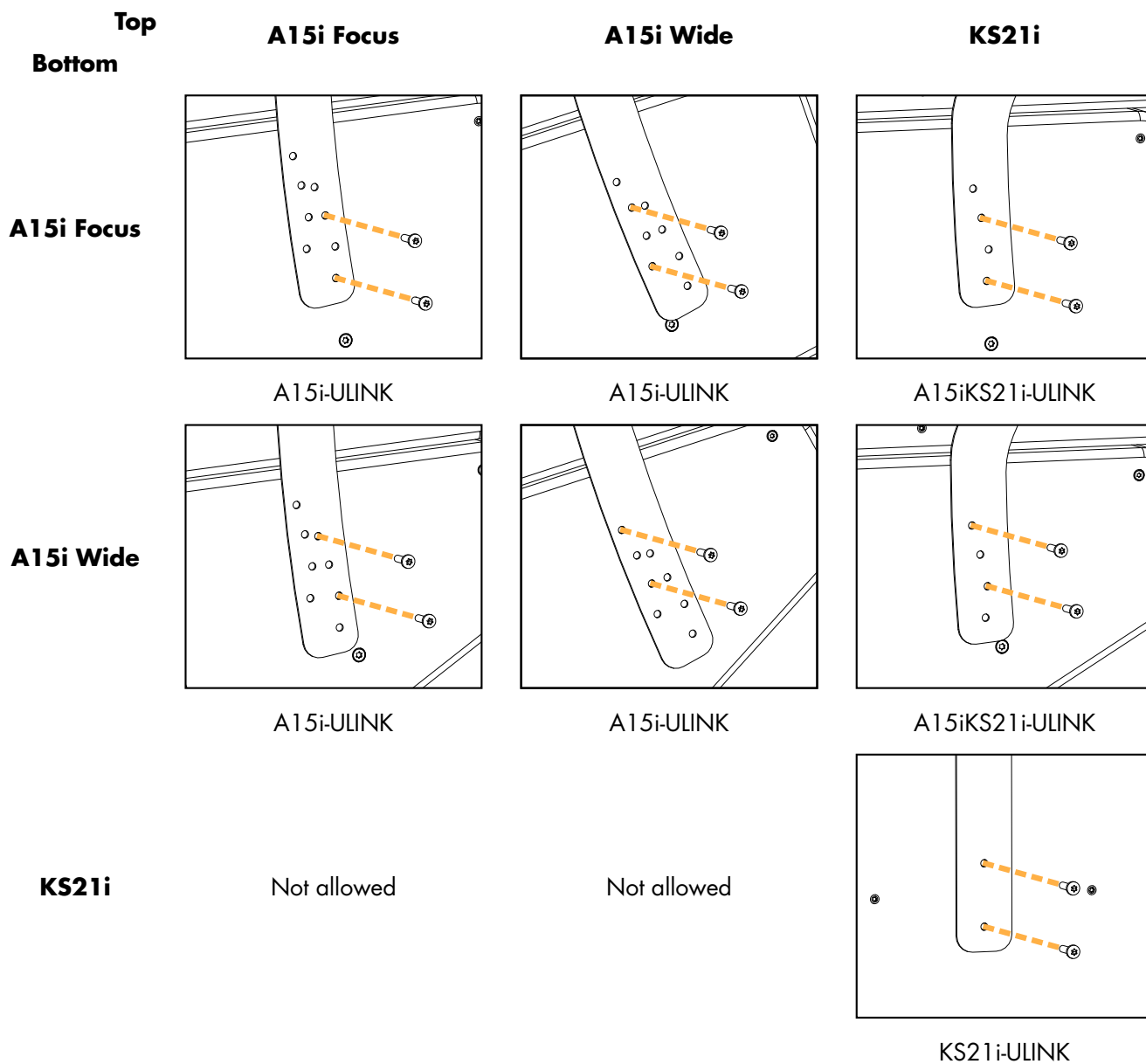

If the two enclosures are misaligned at the front, loosen the screws on the U-rigging plates and realign the two enclosures, then re-tighten the screws.

What to do next

[Securing a screen](#) (p.104)

Mounting an assembly on a ceiling with A15i-TILTBRACKET

Type of deployment	ceiling-mounting
Rigging accessories	A15i-TILTBRACKET A15i Wide/Focus rigging plates
Additional accessories	M6x18 rigging screws (provided) 4 x M10 screws and anchors T30 Torx bits
Min number of operators	3

Rigging plates

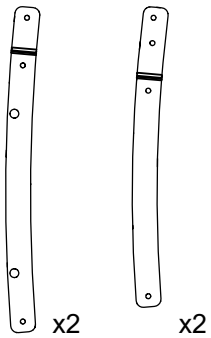

A15iFOCUS-LINK
Rigging plates
for A15i Focus

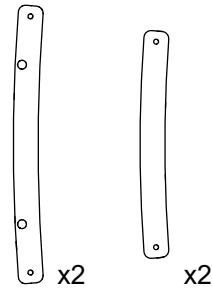

A15iFOCUS-ENDLINK
End rigging plates
for A15i Focus

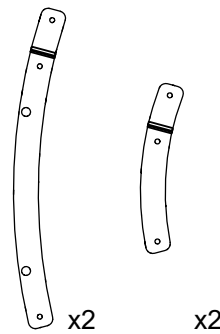

A15iWIDE-LINK
Rigging plates
for A15i Wide

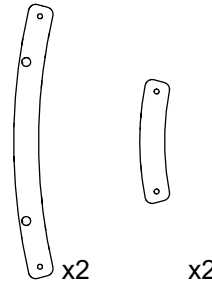

A15iWIDE-ENDLINK
End rigging plates
for A15i Wide

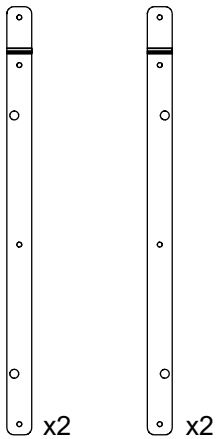

KS21i-LINK
Rigging plates
for KS21i

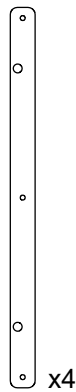

KS21i-
ENDLINK
End rigging
plates for
KS21i

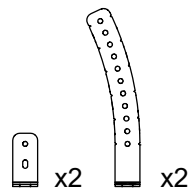

A15i-TILTBRACKET
Fastening brackets
with angles for A15i



Ai-FIXBRACKET / A15i-TILTBRACKET in ceiling-mounted configuration

In a ceiling-mounted configuration, the array applies a force of **60 daN** on the anchoring points.

Realized site angles (with A15i-TILTBRACKET at the rear)

selected angle on A15i- TILTBRACKET	realized site angle	
	A15i Focus	A15i Wide
25°	20°	10°
22.5°	17.5°	7.5°
20°	15°	5°
17.5°	12.5°	2.5°
15°	10°	0°
12.5°	7.5°	-2.5°
10°	5°	-5°
7.5°	2.5°	-7.5°
5°	0°	-10°
2.5°	-2.5	-12.5°
0°	-5	-15°

Assembly**Procedure**

1. Secure A15i-TILTBRACKET to the ceiling using M10 screws.

**Fasteners for wall-mounting or ceiling-mounting**

Select screw length and anchors applicable to the wall or ceiling properties.

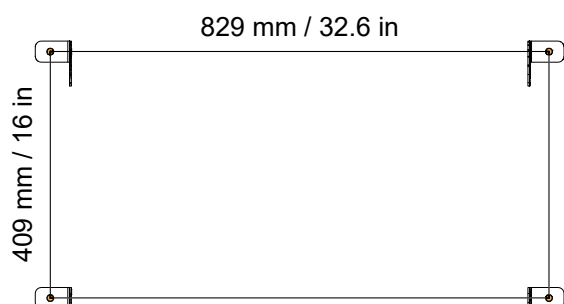

2. Prepare an enclosure by removing the placeholder screws and securing end rigging plates on both sides.

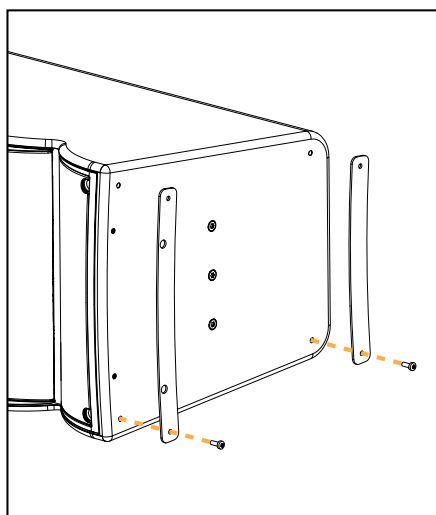

3. Secure the front of the enclosure to Ai-FIXBRACKET.

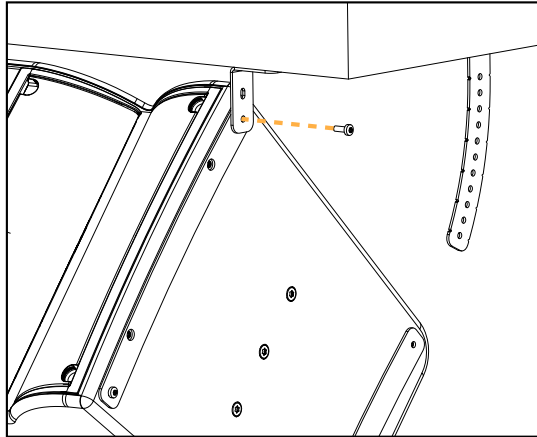
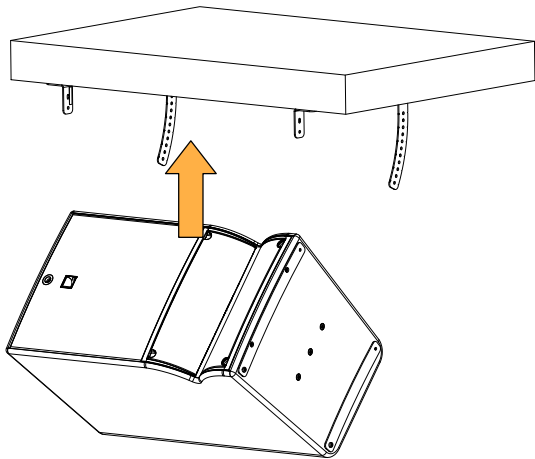

4. Lift the rear of the enclosure and secure it to A15i-TILTBRACKET at the desired angle.

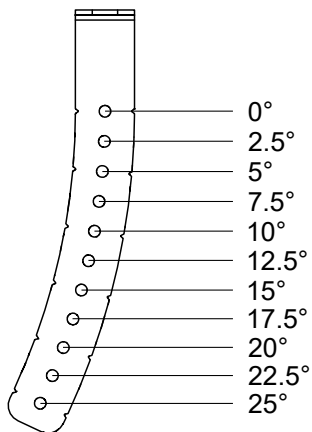
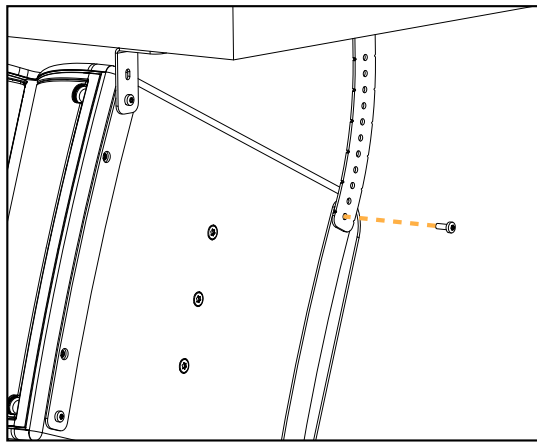
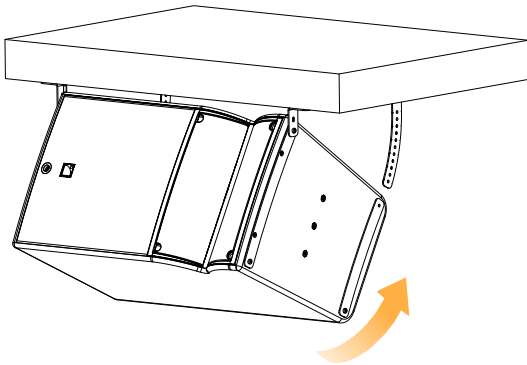

5. Tighten the screws on A15i-TILTBRACKET (5 N.m torque).

6. Prepare a new enclosure by removing the placeholder screws and securing rigging plates.

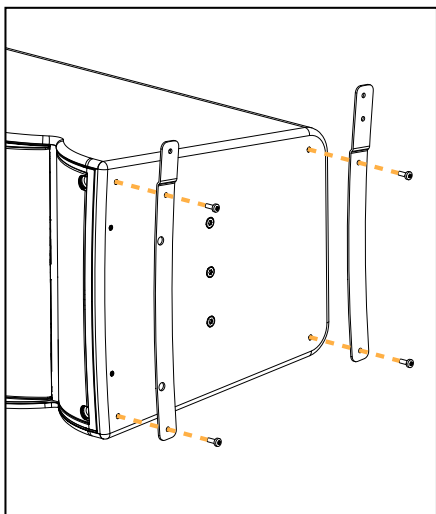

7. Remove the bottom screws of the supporting enclosure.

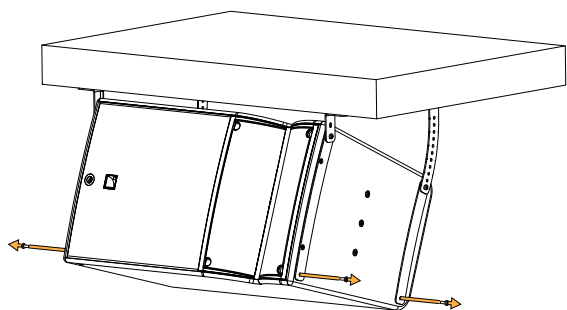

8. Link the two enclosures at the rear by pre-tightening a rigging screw on both sides.



This step requires three operators.

Hold the enclosure at the bottom until the rigging plates are secured.



A15i Focus site angle adjustment

A15iFOCUS-LINK can be used to add an inter-element angle of 5° between two A15i Focus.

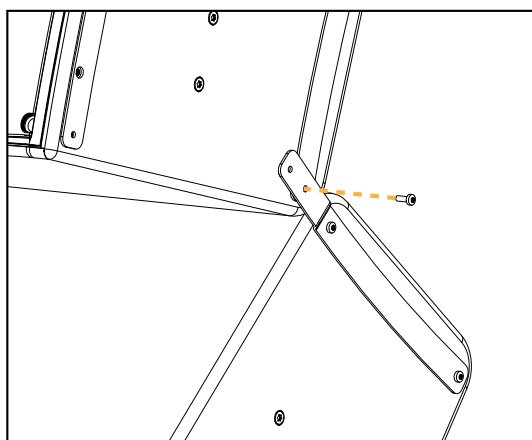
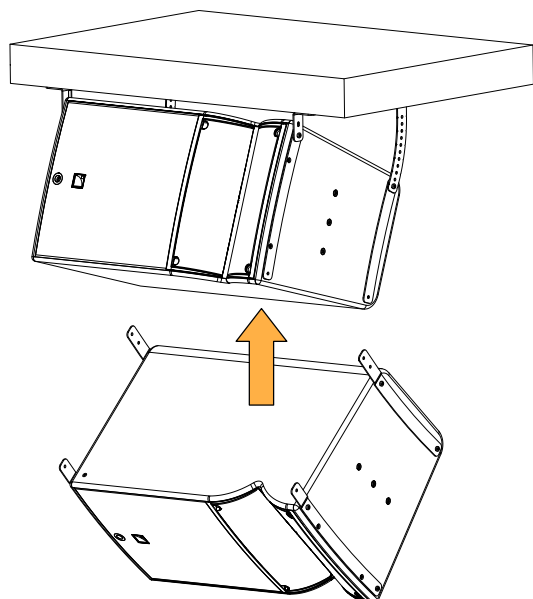

9. Link the two enclosures at the front by pre-tightening a rigging screw on both sides.

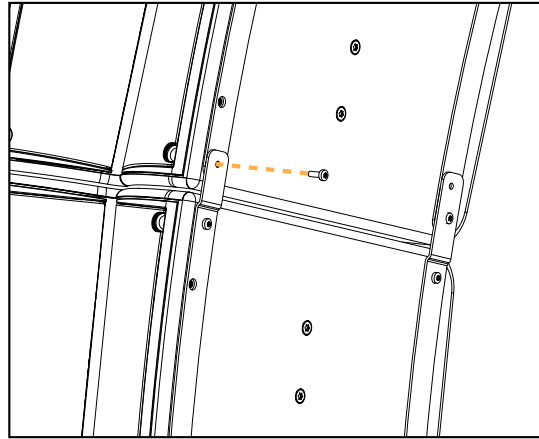
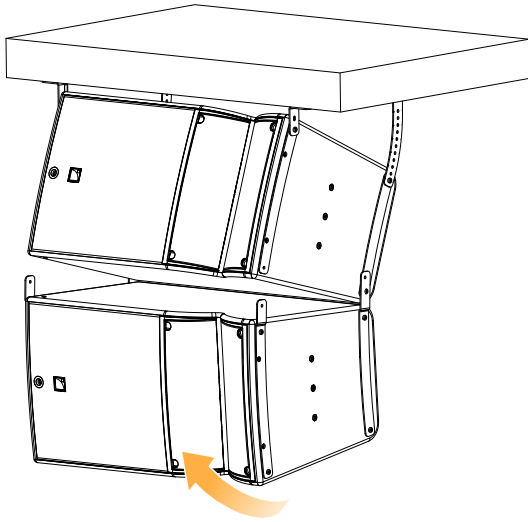

10. Check that all the screws are secured and tightened (5 N.m torque).

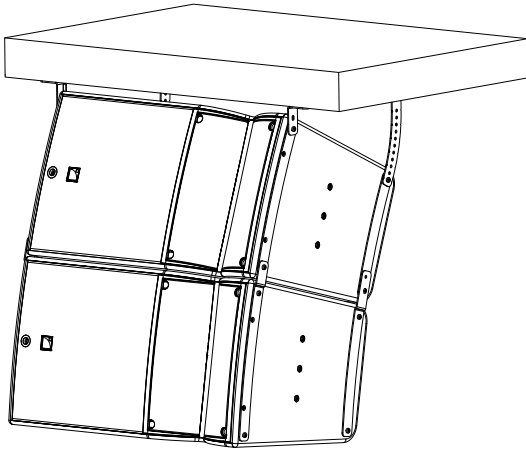

What to do next

[Securing a screen](#) (p.104)

Stacking

Stacking A15i Wide/Focus on KS21i with A15i-TILT

Type of deployment	stacked array
Rigging accessories	A15i Wide/Focus / KS21i rigging plates Ai-FIXBRACKET A15i-TILT
Additional accessories	M6x18 rigging screws (provided) 4 x M10 screws and anchors T30 Torx bits
Min number of operators	2

Rigging plates

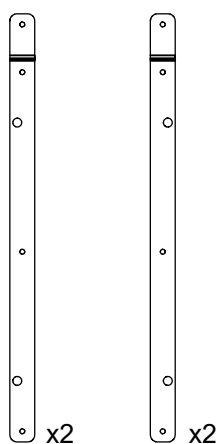

KS21i-LINK

Rigging plates for KS21i

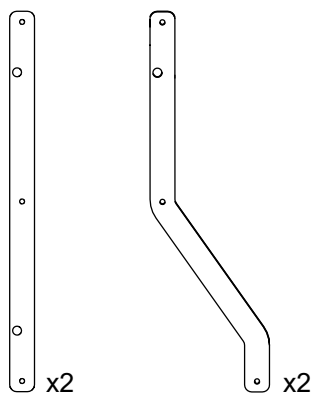

KS21i-ENDSLINK

End rigging plates for A15i under KS21i

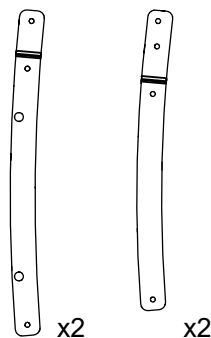

A15iFOCUS-LINK

Rigging plates for A15i Focus

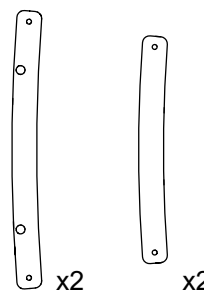

A15iFOCUS-ENDLINK

End rigging plates for A15i Focus

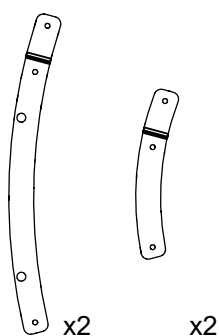

A15iWIDE-LINK

Rigging plates for A15i Wide

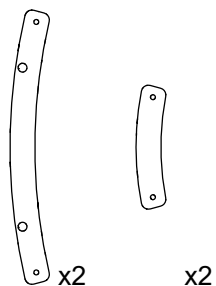

A15iWIDE-ENDLINK

End rigging plates for A15i Wide

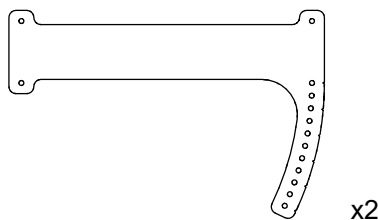

A15i-TILT

Rigging elements with angles for A15i above or under KS21i



Risk of falling objects

Verify that no unattached items remain on the product or assembly.



Fastening brackets

Always secure a stacked array to the ground using Ai-FIXBRACKET / A15i-TILTBRACKET to ensure stability of the array.

**Ai-FIXBRACKET / A15i-TILTBRACKET in stacked configuration**

In a stacked configuration, the array applies a force of **110 daN** on the anchoring points.



Do not use A15i-TILT between two A15i Wide/Focus.

Realized site angles (with A15i-TILT at the rear)

selected angle on A15i-TILT	realized site angle	
	A15i Focus	A15i Wide
-25°	-20°	-10°
-22.5°	-17.5°	-7.5°
-20°	-15°	-5°
-17.5°	-12.5°	-2.5°
-15°	-10°	0°
-12.5°	-7.5°	2.5°
-10°	-5°	5°
-7.5°	-2.5°	7.5°
-5°	0°	10°
-2.5°	2.5	12.5°
0°	5	15°

Assembly

Procedure

1. Prepare a KS21i by removing the placeholder screws and securing rigging plates on both sides.

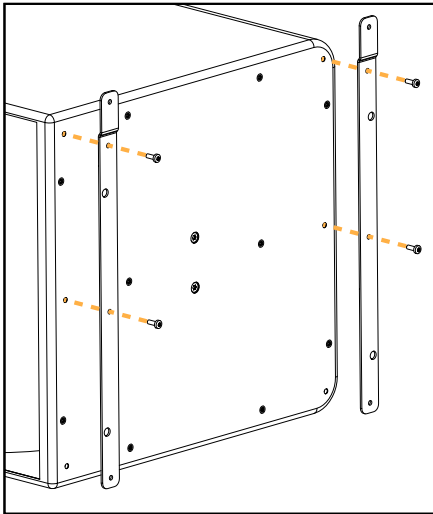

2. Secure Ai-FIXBRACKET to the ground using M10 screws.



Fasteners for wall-mounting or ceiling-mounting

Select screw length and anchors applicable to the wall or ceiling properties.

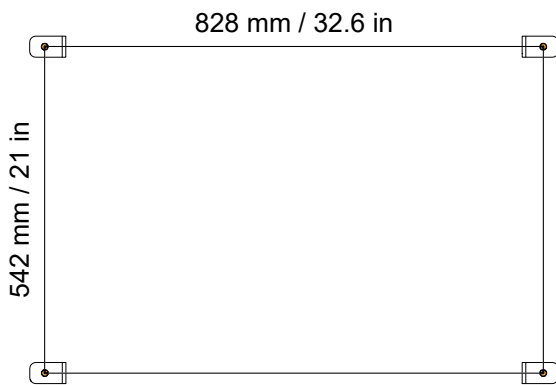

3. Secure KS21i to Ai-FIXBRACKET.

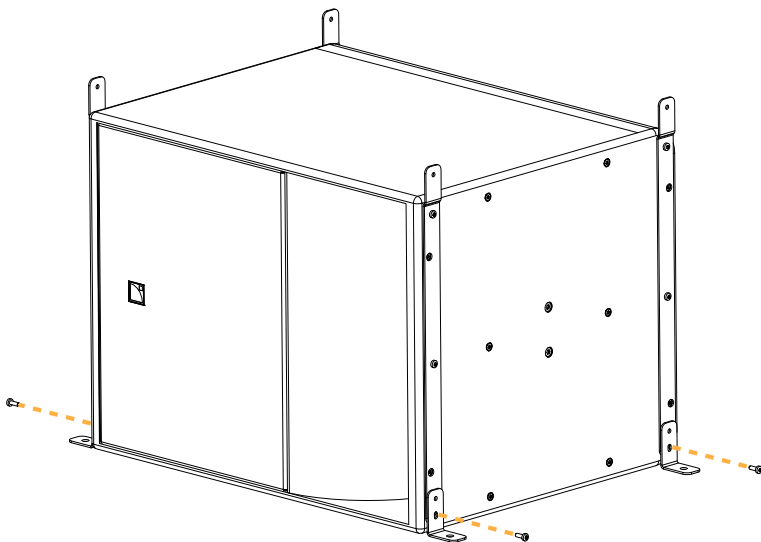

4. Secure up to three additional KS21i on top of the first one.

For the last KS21i, use KS21i-ENDSLINK and secure A15i-TILT on top.

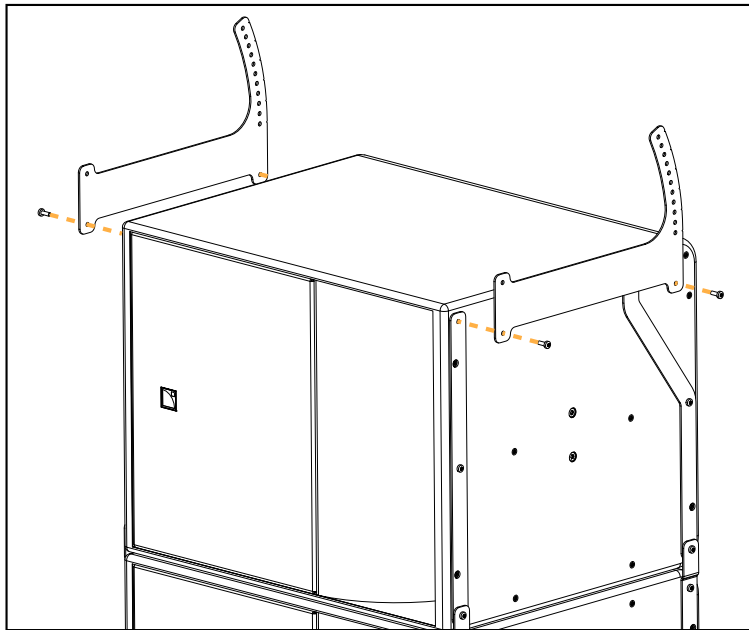
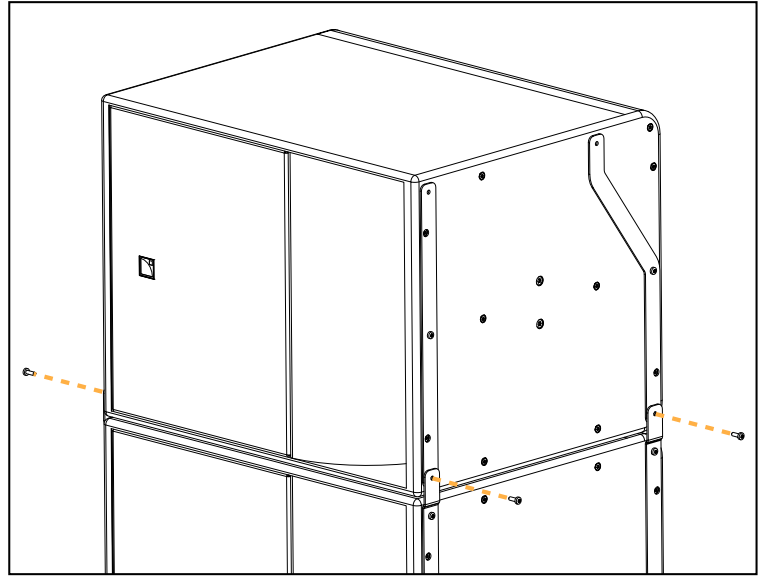
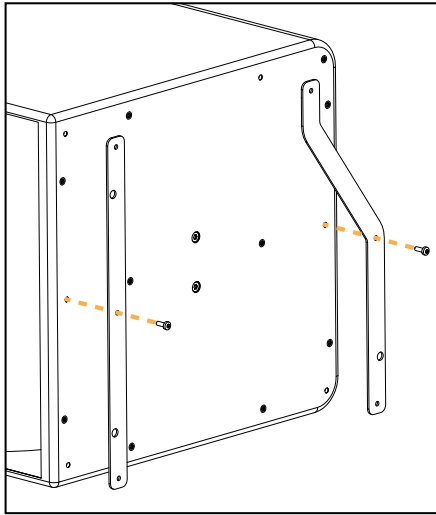

Tighten all the screws on the previous enclosure after securing each new enclosure.

5. Prepare a A15i Wide/Focus by removing the placeholder screws and securing rigging plates on both sides.

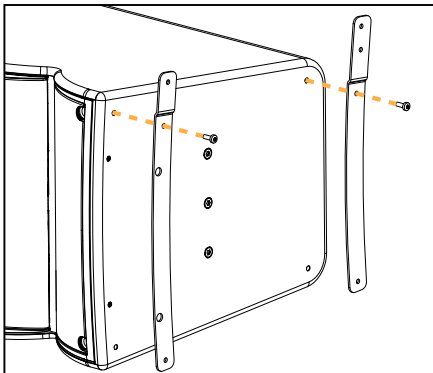

6. Secure the front of A15i Wide/Focus on top of the array.

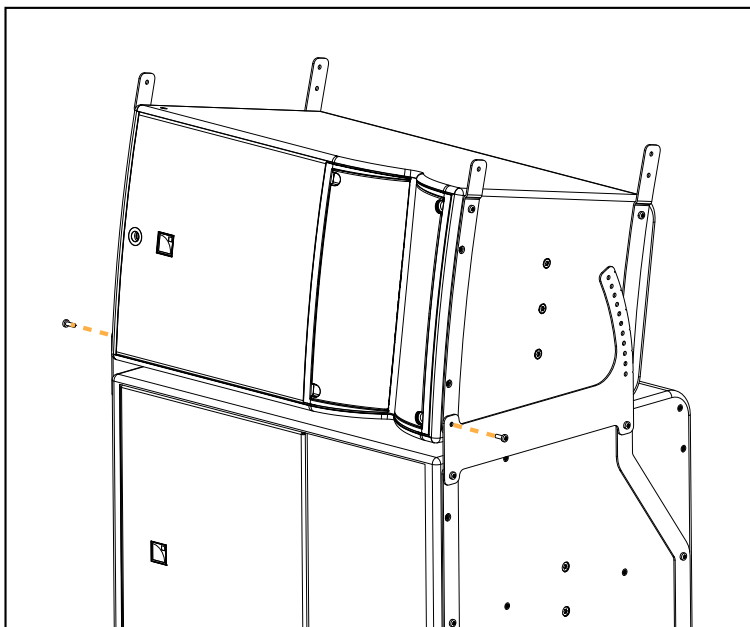

7. Secure the rear of the enclosure to A15i-TILT at the selected angle.



Risk of crushing injury

Keep fingers away from the contact area between A15i-TILT and the enclosure.

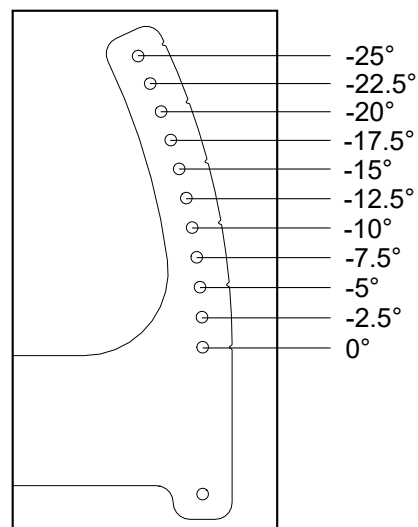
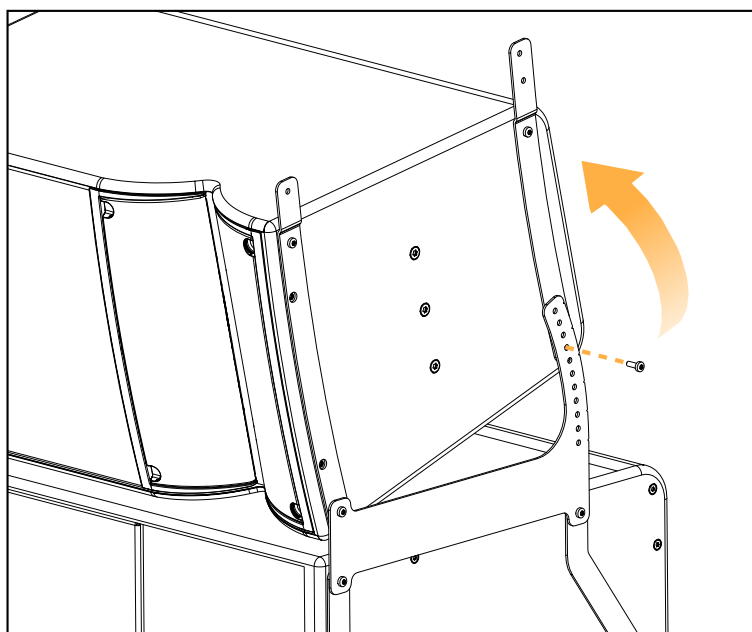

8. Secure up to three additional A15i Wide/Focus on top of the first one.
For the last A15i Wide/Focus, use A15iFOCUS-ENDLINK / A15iWIDE-LINK.

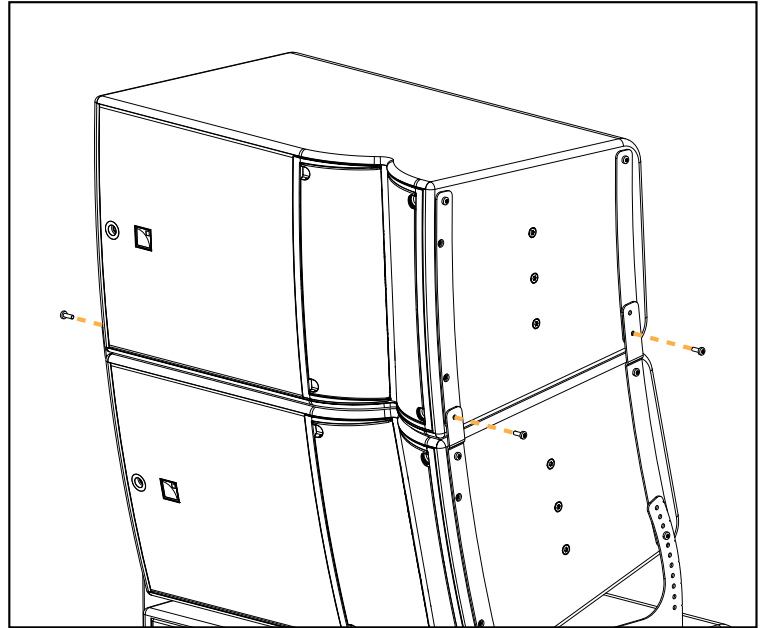
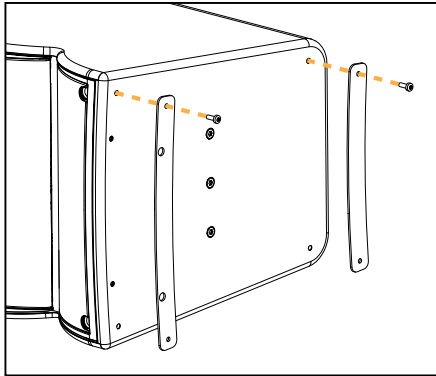

What to do next

[Securing a screen](#) (p.104)

Stacking A15i Wide/Focus with A15i-TILTBRACKET

Type of deployment	stacked assembly
Rigging accessories	A15i Wide/Focus rigging plates A15i-TILTBRACKET
Additional accessories	M6x18 rigging screws (provided) 4 x M10 screws and anchors T30 Torx bits
Min number of operators	2

Rigging plates

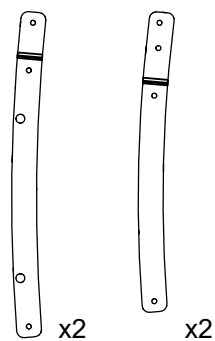

A15iFOCUS-LINK
Rigging plates
for A15i Focus

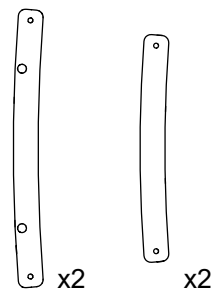

A15iFOCUS-ENDLINK
End rigging plates
for A15i Focus

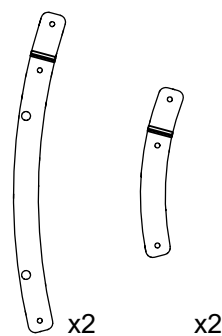

A15iWIDE-LINK
Rigging plates
for A15i Wide

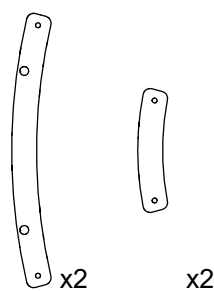

A15iWIDE-ENDLINK
End rigging plates
for A15i Wide

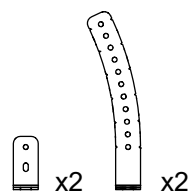

A15i-TILTBRACKET
Fastening brackets
with angles for A15i



Ai-FIXBRACKET / A15i-TILTBRACKET in stacked configuration

In a stacked configuration, the array applies a force of **110 daN** on the anchoring points.

Assembly

Procedure

1. Prepare a A15i Wide/Focus by removing the placeholder screws and securing rigging plates on both sides.

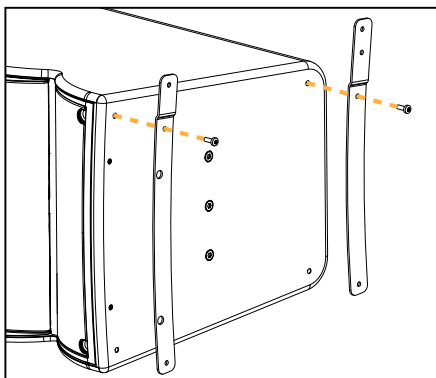

2. Secure A15i-TILTBRACKET to the ground using M10 screws.



Fasteners for wall-mounting or ceiling-mounting

Select screw length and anchors applicable to the wall or ceiling properties.

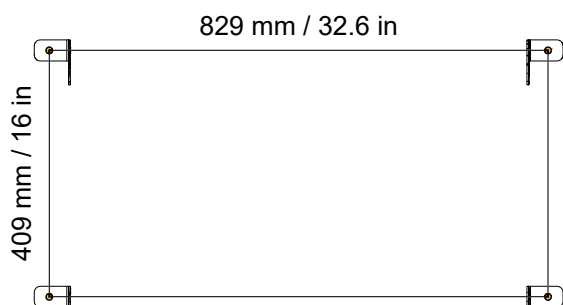

3. Secure the front of A15i Wide/Focus to the front brackets by pre-tightening a screw in the top hole of the front brackets.

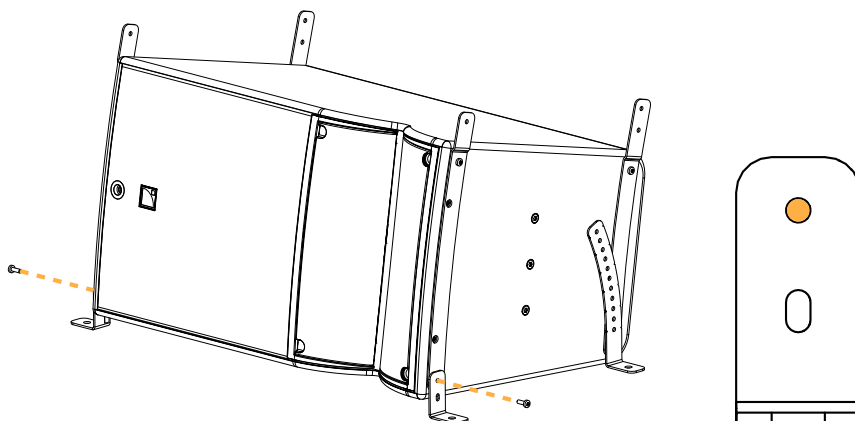

4. Secure the rear of the enclosure to A15i-TILTBRACKET at the desired angle.

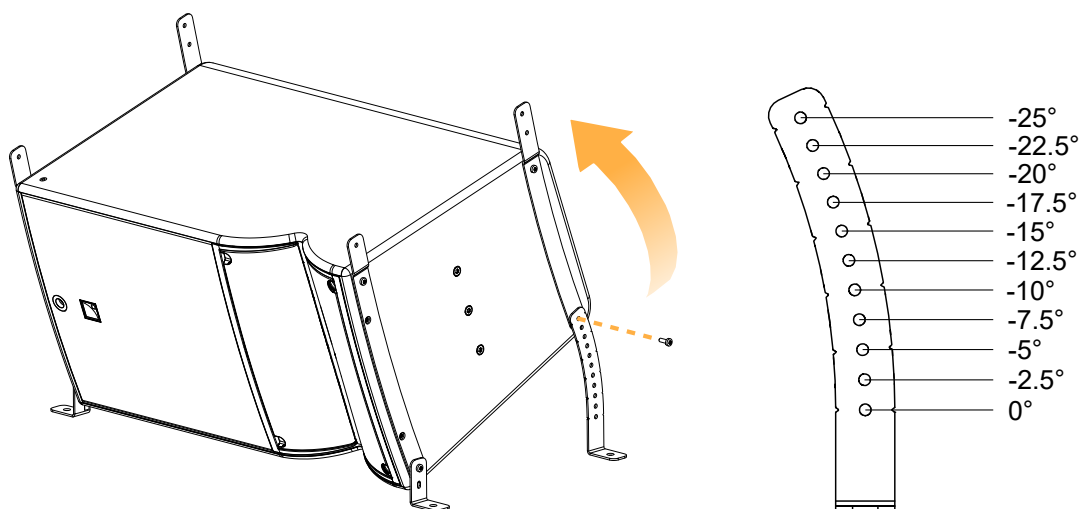

5. Tighten the screws on A15i-TILTBRACKET.
 6. Prepare a new A15i Wide/Focus enclosure by removing the placeholder screws and securing end rigging plates on both sides.

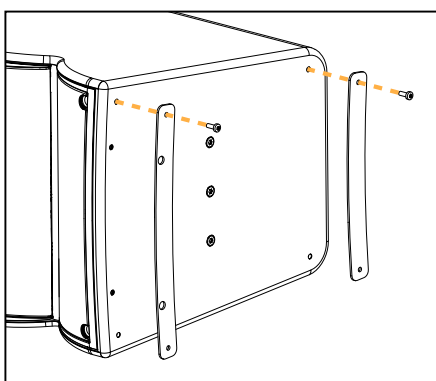

7. Secure the enclosure on top of the assembly.

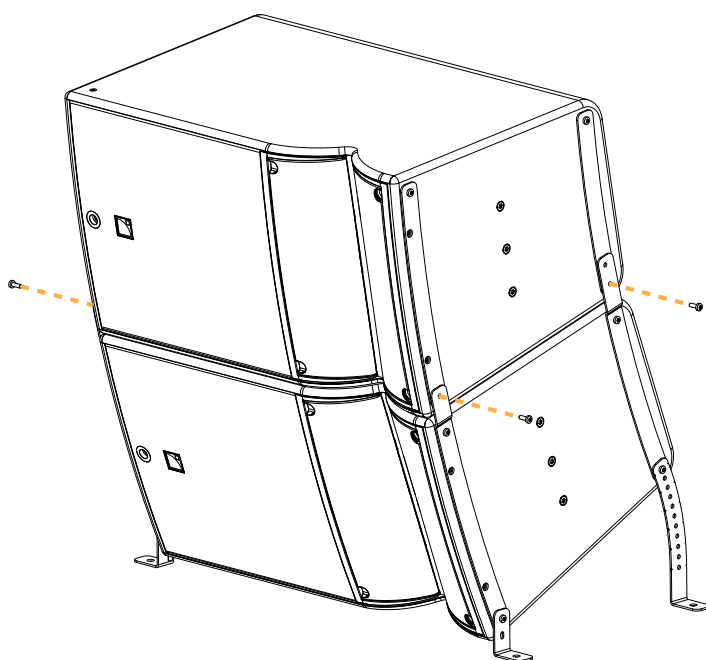

What to do next

[Securing a screen](#) (p.104)

Securing a screen

Accessory	A15iFOCUS-SCREEN / A15iWIDE-SCREEN / A15iFOCUS-SCREEN-LIFT / A15iWIDE-SCREEN-LIFT / KS21i-SCREEN
Additional accessories	2 x M6x20 screws (provided) 2 x M6x35 screws (for A15i Wide/Focus, provided) 2 x M6x55 screws (for KS21i, provided) 4 x self-sticking washers (for configurations with a U-bracket, provided) T30 Torx bit
Min number of operators	1

Assembly

Prerequisite



Secure the screens on the enclosures after the array is fully assembled.

About this task



In radial configurations, use A15iFOCUS-SCREEN-LIFT/A15iWIDE-SCREEN-LIFT for enclosures on which A15i-LIFT is secured.

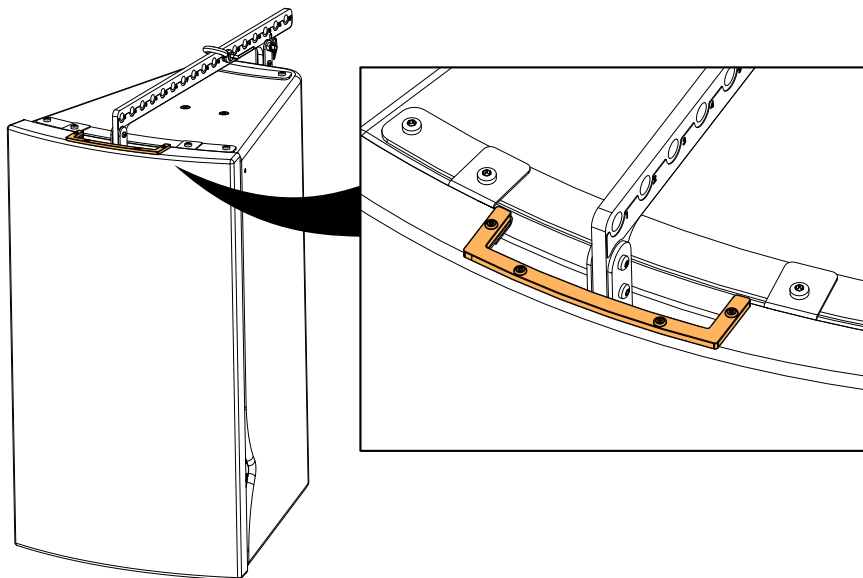

Procedure

1. Remove the placeholder screws on the fins side and the grill screws from the inserts.

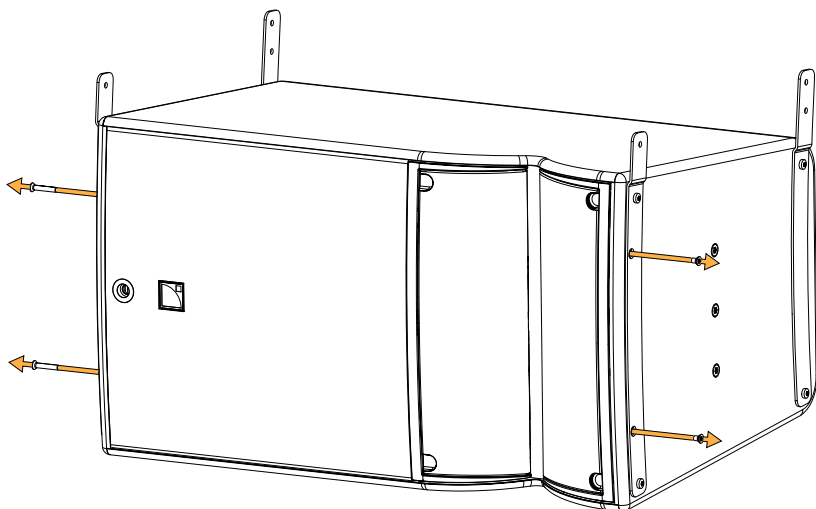

2. Secure the screen using the provided rigging screws.

Apply a torque of 5 N.m.



Risk of damaging the fins

When securing a screen to A15i Wide/Focus, make sure to use M6x20 screws on the fins side.

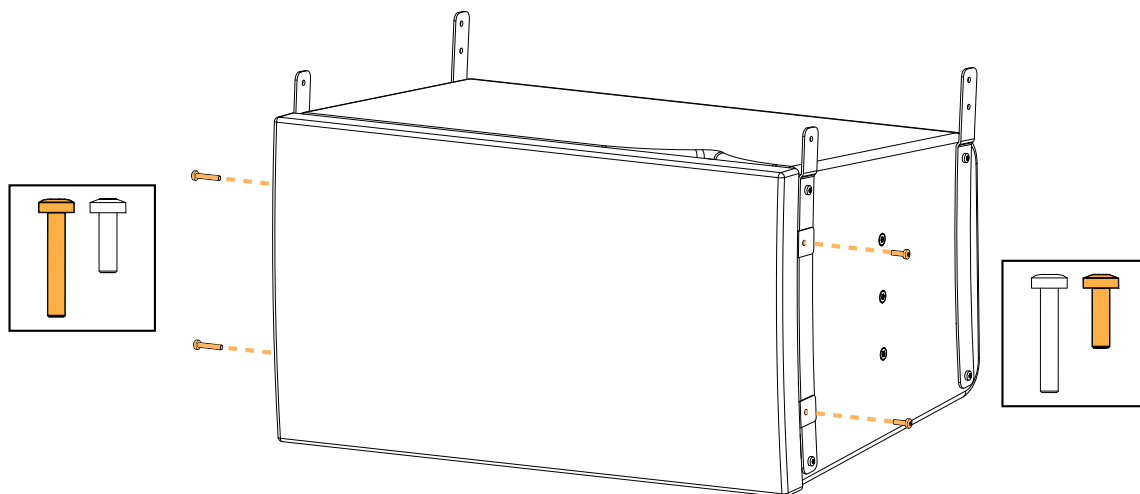

For configurations with A-U15i, stick the provided washers to the screen before securing it on the enclosure.

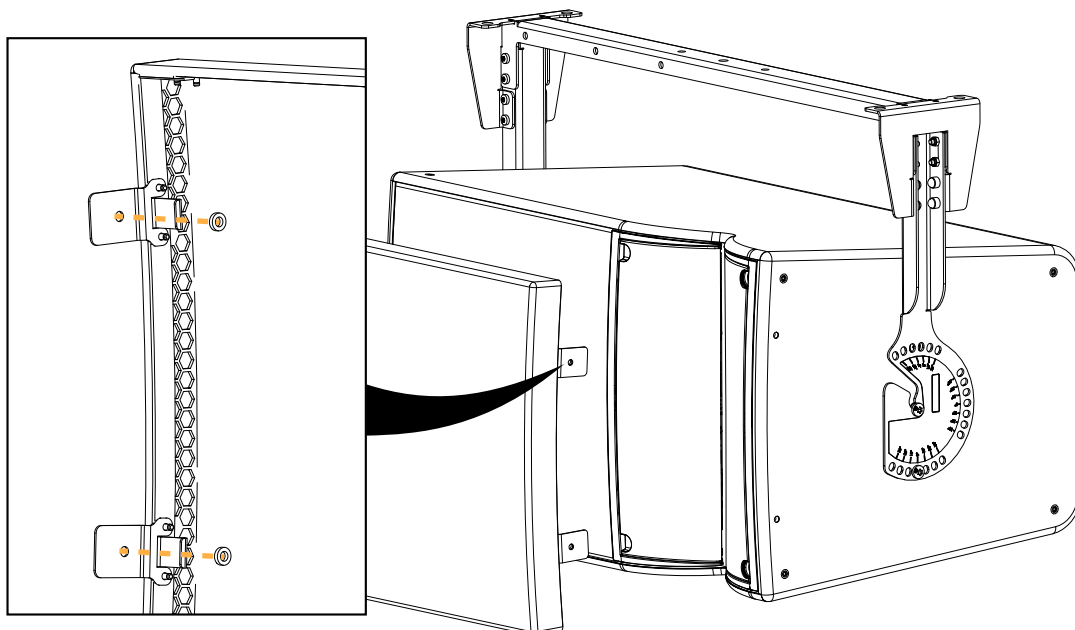

! Risk of bending screen fixing tabs

Always use the self-sticking washers for securing screens when there are no rigging plates on the enclosure.

! If KS21i is reversed (cardioid configuration), connect the cables to the enclosure before securing KS21i-SCREEN.

Pass the cables through the cutout on the screen side.

See [Connection to LA amplified controllers](#) (p.107) for cabling instructions.

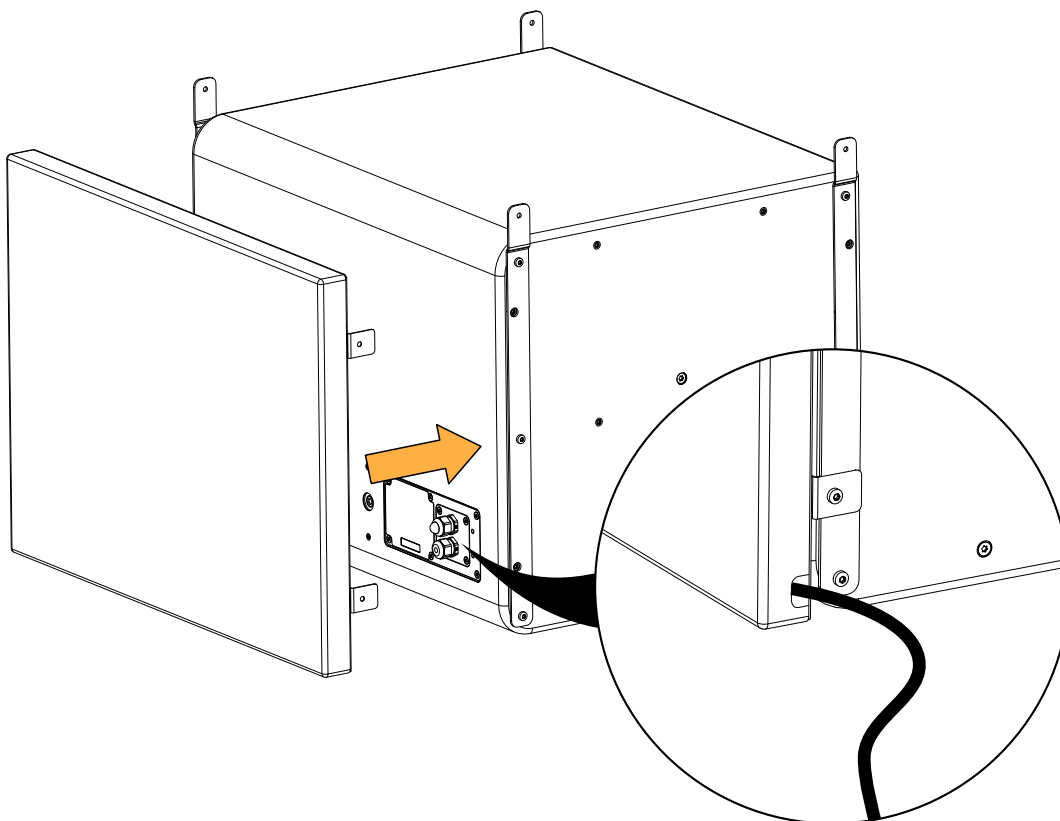

Connection to LA amplified controllers

Enclosure drive capacity per amplified controller

Make sure the total number of connected enclosures does not exceed the maximum number of enclosures per controller (refer to the footnotes).

	LA2Xi	LA4X	LA8	LA12X
	per output [*] / total	per output [*] / total	per output [*] / total	per output [*] / total
A15i Wide/Focus	1 / 4 (SE), 1 / 2 (BTL)	1 / 4	2 / 8	3 / 12
KS21i	1 / 4 (SE), 1 / 2 (BTL)	1 / 4	2 / 6 ^{**}	2 / 8

Cabling schemes

For A15i Wide/Focus / KS21i (LA2Xi)

Refer to the cabling schemes to connect the enclosures to different types of output configurations.

i Refer to the **LA2Xi owner's manual** for more information on output configurations.

Terminal block output (SE)

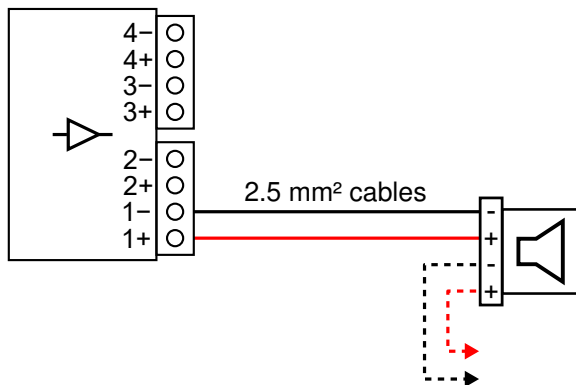

Terminal block output (BTL)

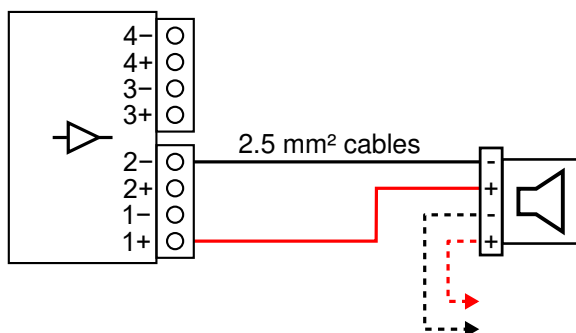

* For passive loudspeakers, the value corresponds to the number of enclosures in parallel on the output. For active loudspeakers, the value corresponds to the number of sections in parallel on the output.

** LA8 can drive up to two KS21 or KS21i per output, but no more than six per controller at high level.

For A15i Wide/Focus / KS21i (LA4X / LA8 / LA12X)

Refer to the cabling schemes to connect the enclosures to different types of output configurations.

One-channel speakON output

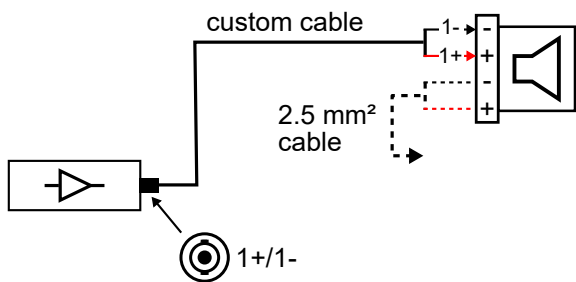

Two-channel speakON output

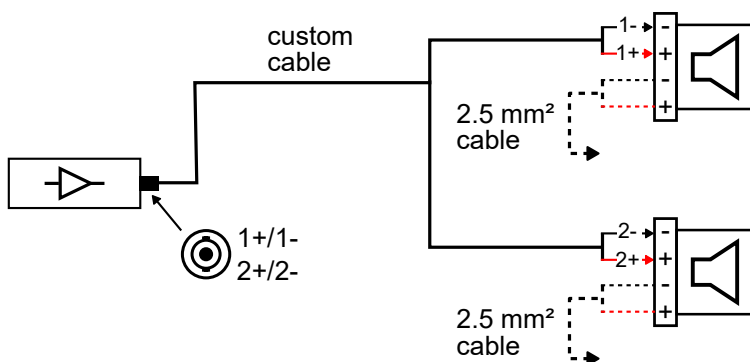

Cabling

Accessory	connector sealing plate (provided)
Screws and fasteners	4 x M5x16 screws (provided)
Tools	torque screwdriver T25 Torx bit small tool or flat screwdriver (3 mm or less)
Min number of operators	1

Assembly

Prerequisite

Refer to:

- [APPENDIX C: Recommendation for speaker cables](#) (p.156)
- [Cabling schemes](#) (p.107)

About this task

The connector sealing plates have two cable glands: one for the input cable and one for the cable connecting to the next enclosure in parallel. The second cable gland is equipped with a protective plug.

This procedure describes how to connect the input cable to the enclosure. If the enclosure must be connected in parallel, remove the protective plug from the second cable gland and proceed identically for both cables.

Procedure

1. On the connector sealing plate, remove the sealing nut from the cable gland.

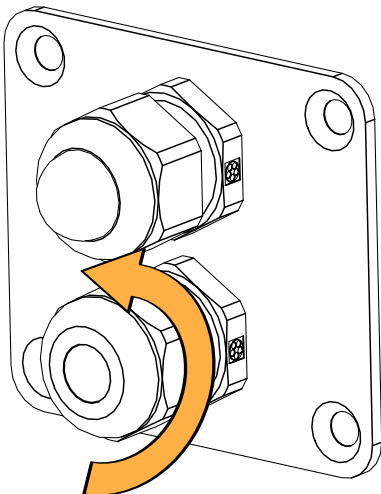

2. Insert the cable through the sealing nut and the cable gland.

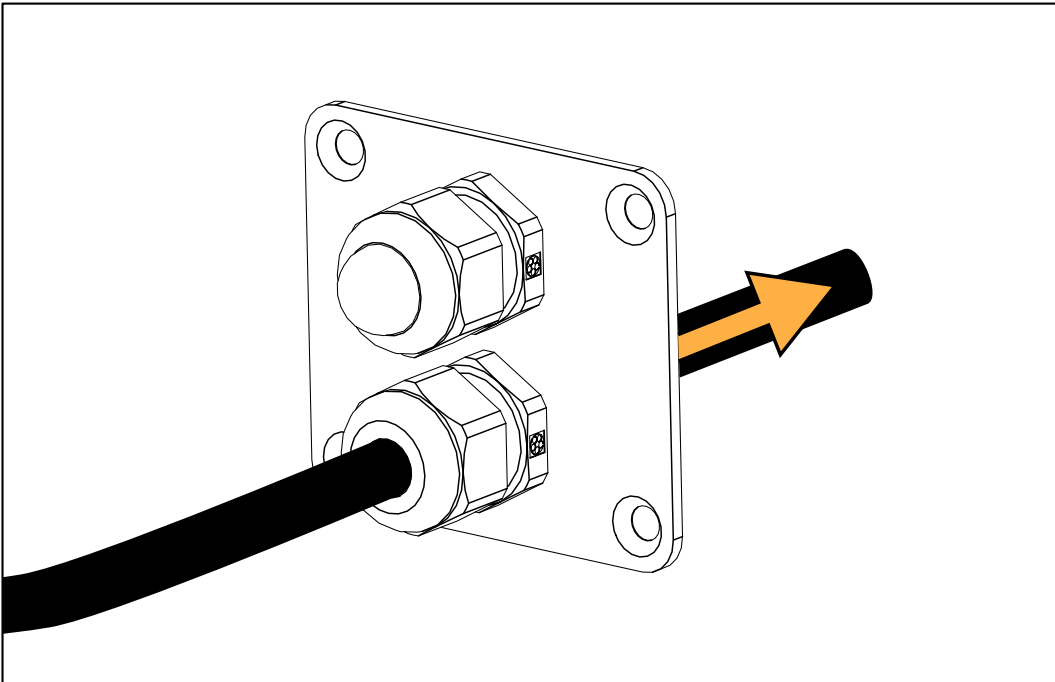
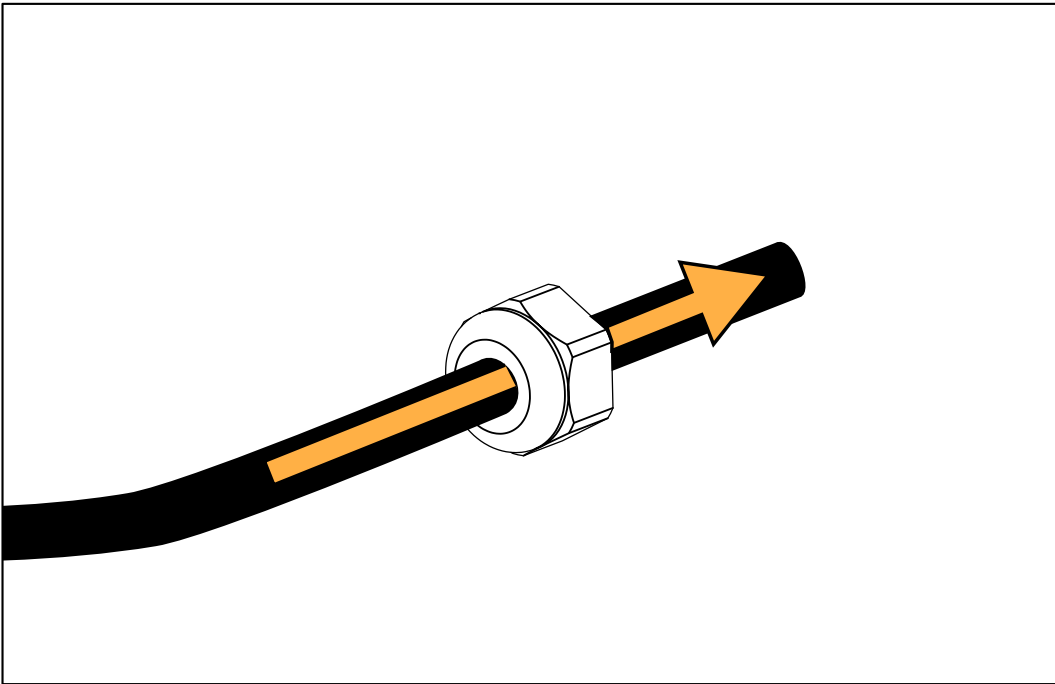

3. Strip the wires of the cable.

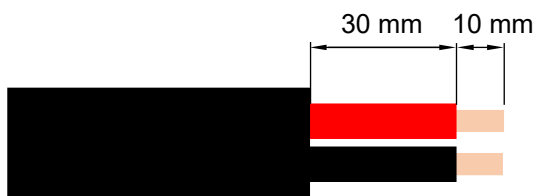

2 x 2.5 mm cable

! Refer to the cable manufacturer documentation for the wire color code.

4. Push the wires into the terminals.

If necessary, use a small tool in the hole next to the terminal to unlock it.

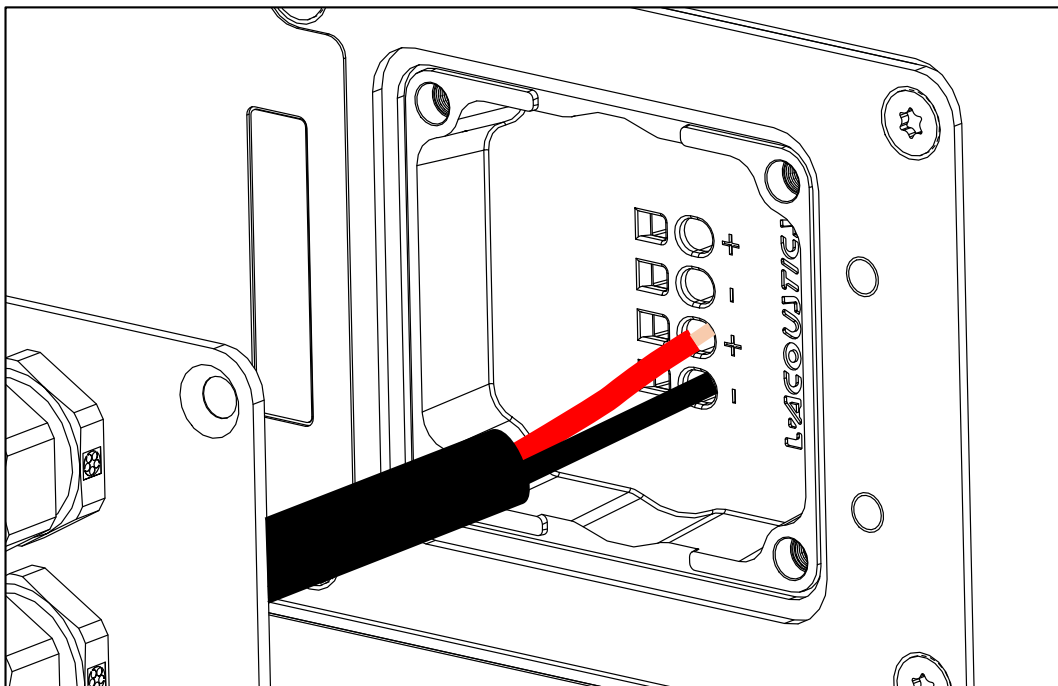

5. Secure the connector sealing plate to the connector plate.

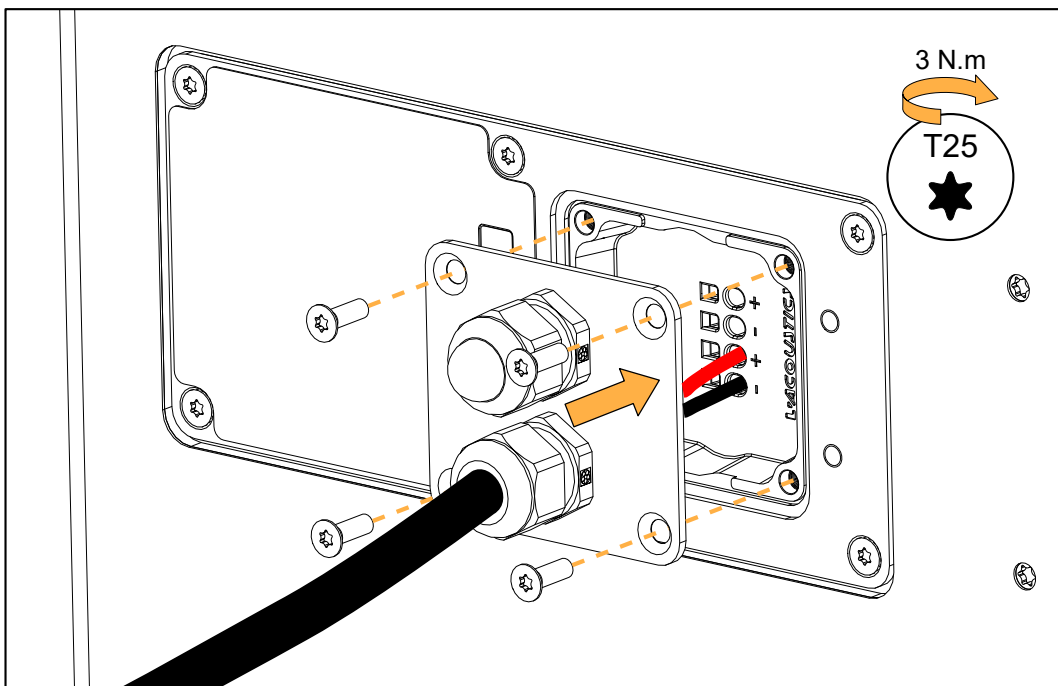

6. Tighten the sealing nut.

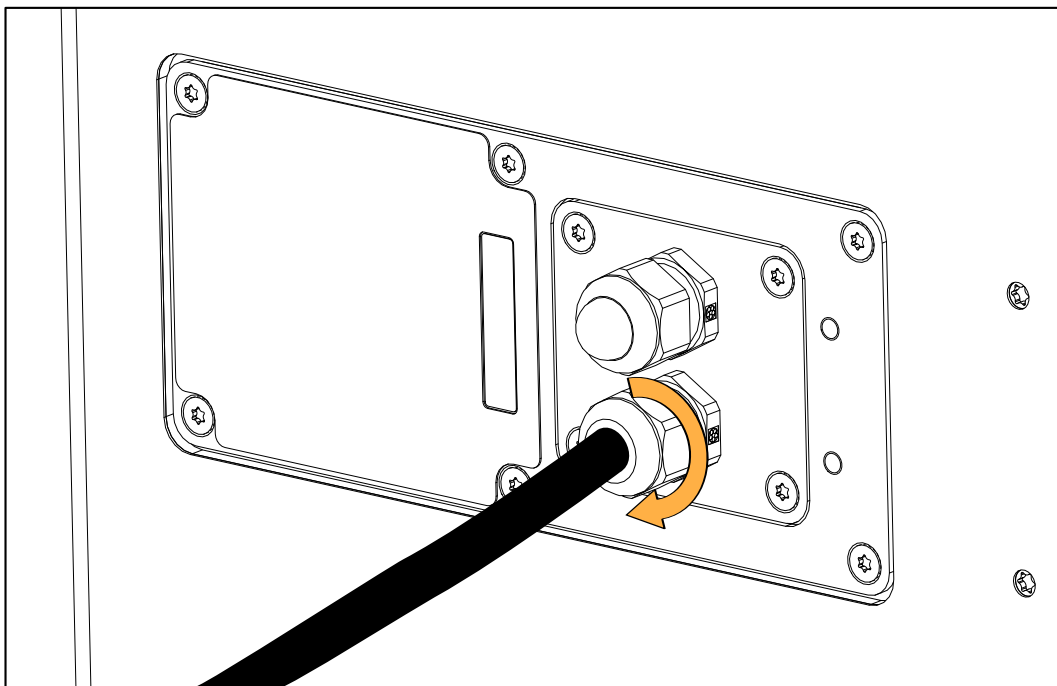

What to do next

To remove the cables use the small tool to unlock the terminals and pull on the wires.

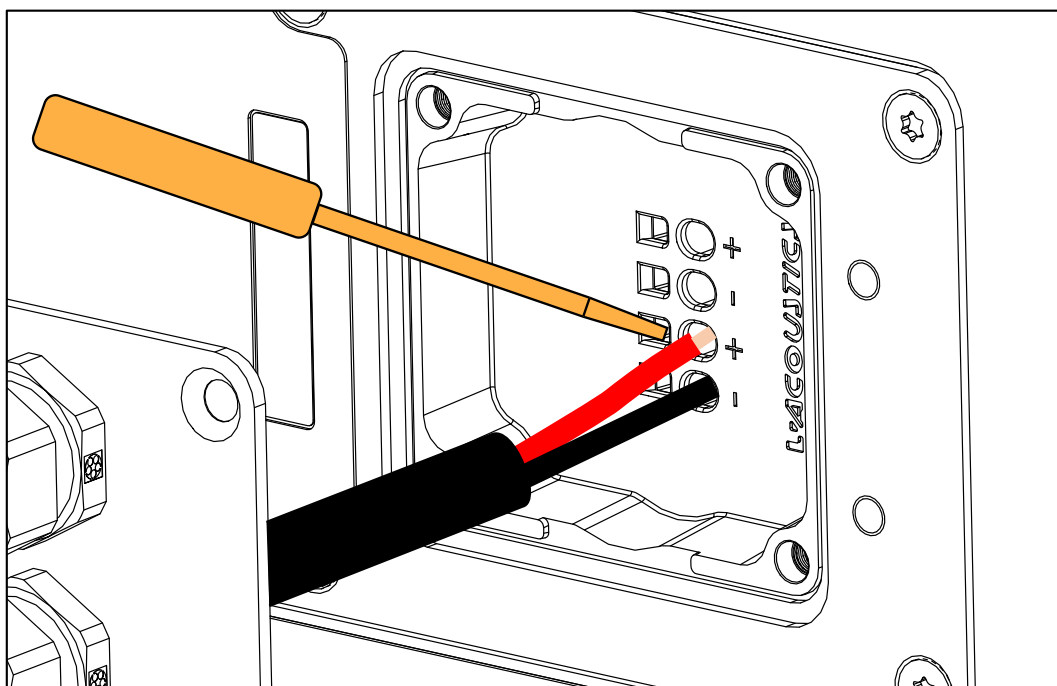

Corrective maintenance

A15i Focus

Introduction

This section contains the following maintenance procedures:

- [Grill](#) (p.114)
- [Fin](#) (p.115)
- [LF speaker](#) (p.116)
- [Connector plate](#) (p.117)
- [HF driver](#) (p.118)
- [HF diaphragm](#) (p.119)

For advanced maintenance, contact your L-Acoustics representative.

Exploded view

In order to operate, follow the order outlined here. Each assembly refers to the corresponding Disassembly/Reassembly (D/R) procedure and the necessary repair kit.

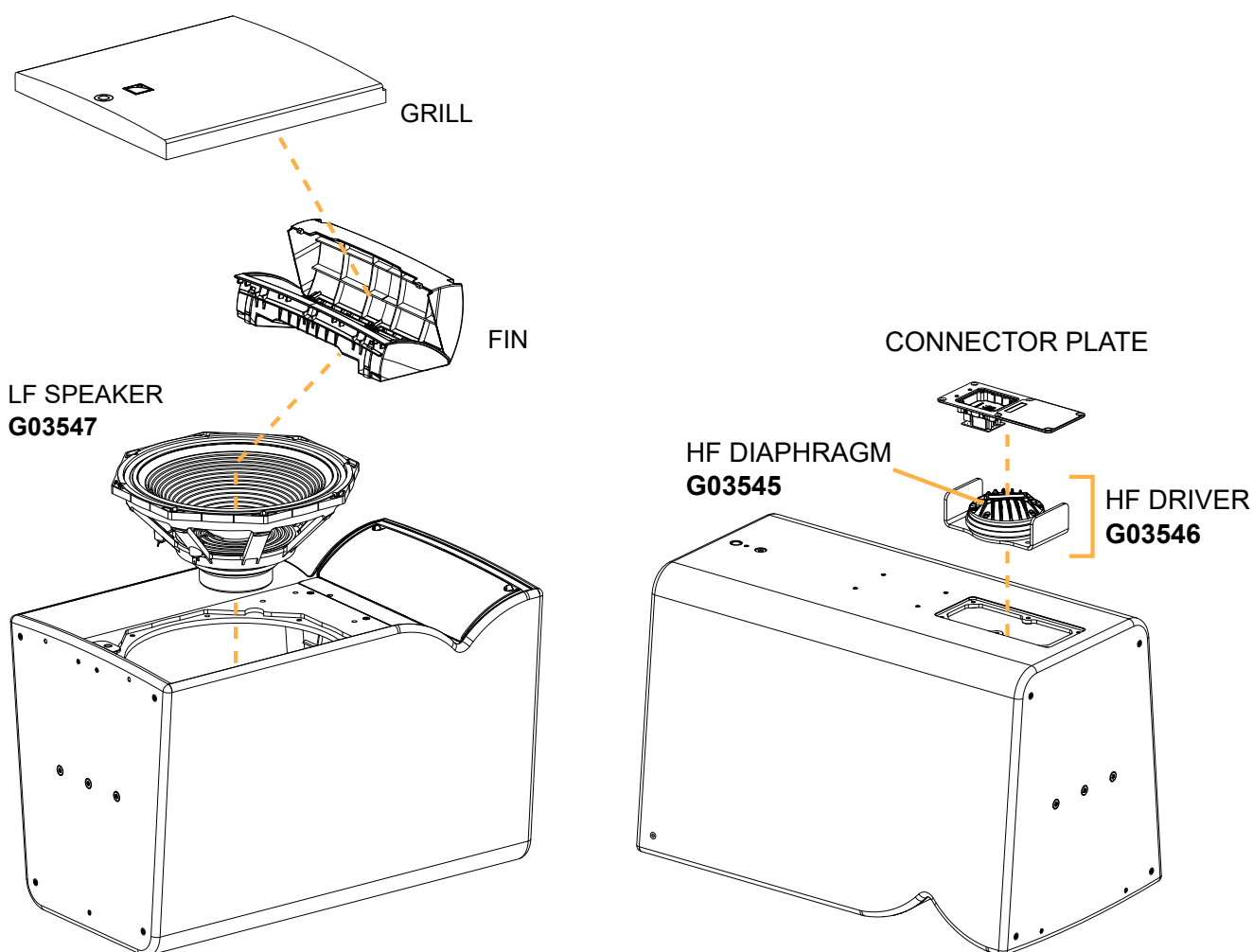

Disassembly and reassembly procedures

D/R - Grill

Tools

- torque screwdriver
- T30 Torx bit

Repair kit

G03547

KR loudspeaker 15" A15i

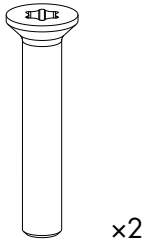

S221

M6x35 Torx

Exploded view



For safety reasons, always use the new screws and spare parts provided in the KR.
If no new screws are available, use blue threadlocker.

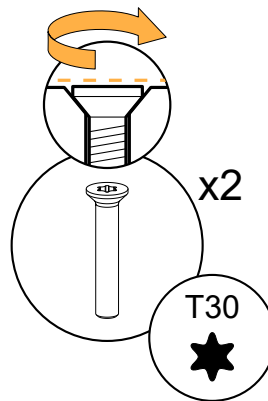
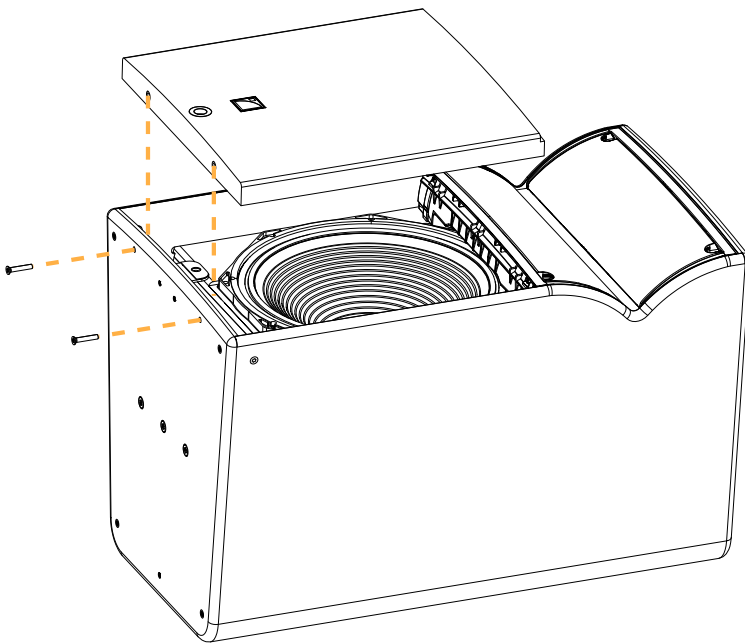

D/R - Fin

Tools

- torque screwdriver
- T30 Torx bit
- flat plastic tool

Repair kit

G03547

KR loudspeaker 15" A15i

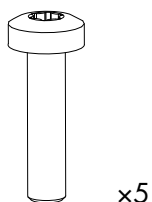

S100143

M6x25 Torx

Prerequisite

Grill removed.

See [Grill](#) (p.114).

Exploded view



For safety reasons, always use the new screws and spare parts provided in the KR.
If no new screws are available, use blue threadlocker.



Use a flat tool made of **smooth plastic** to avoid scratching the fins.

With the flat tool, unhook the fin clips one by one.

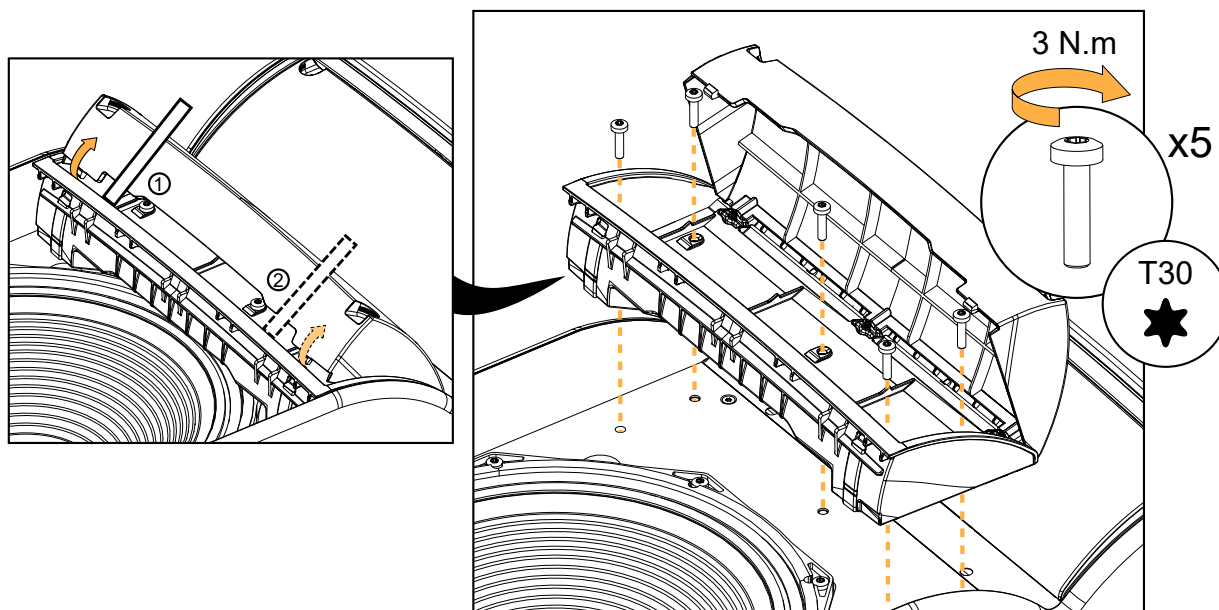

D/R - LF speaker

Tools

- torque screwdriver
- T30 Torx bit

Repair kit

G03547

KR loudspeaker 15" A15i

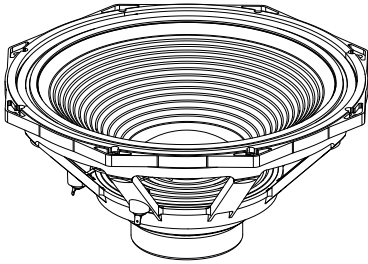

x1

17873

15" LF speaker - 8 Ω (with gasket)

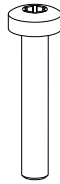

x8

S247

M6x35 Torx

Prerequisite

Grill removed.

See [Grill](#) (p.114).

Fin removed.

See [Fin](#) (p.115).

Exploded view



For safety reasons, always use the new screws and spare parts provided in the KR.
If no new screws are available, use blue threadlocker.

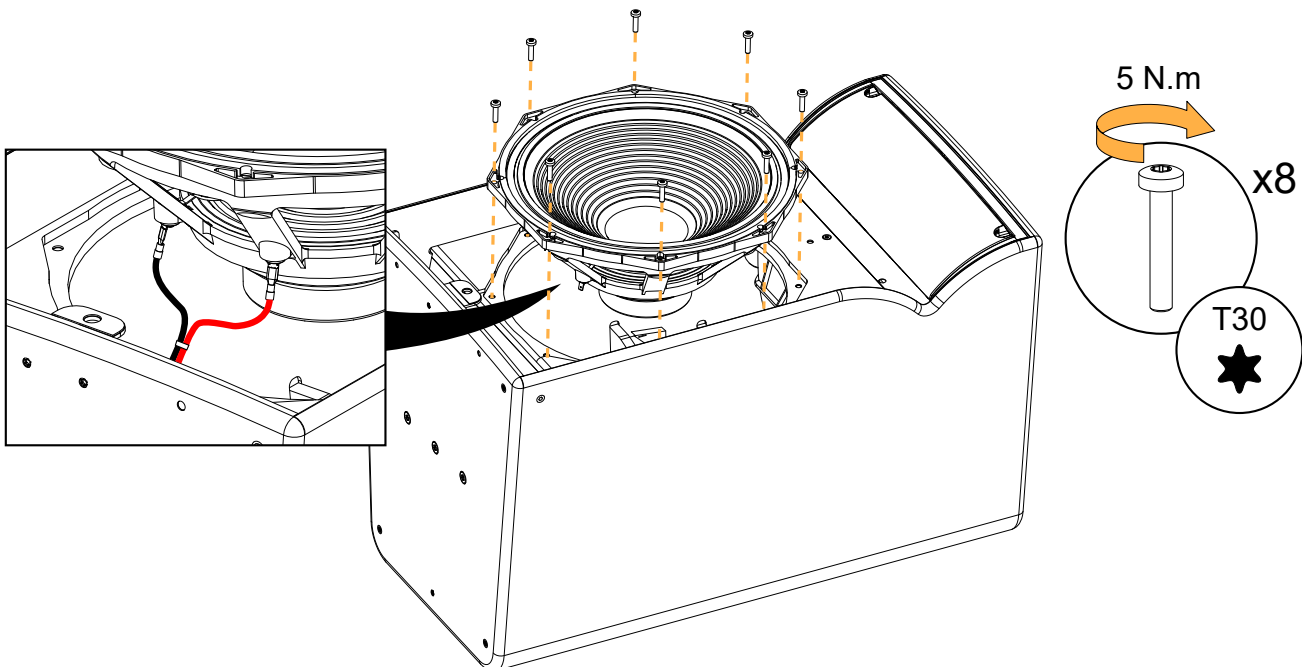

What to do next

Perform the [Acoustical check](#) (p.55) procedures.

D/R - Connector plate

Tools

- torque screwdriver
- T25 Torx bit
- flat tool

Repair kits

G03546 - KR compression driver 3" A15i or

G03545 - KR diaphragm 3" A15i

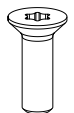

x6

S100086

M5x16 Torx

Exploded view



For safety reasons, always use the new screws and spare parts provided in the KR.
If no new screws are available, use blue threadlocker.



Gradually tighten the screws following a star pattern.

Use a flat tool as a lever to remove the connector plate.

Position the connector plate with the connectors towards the middle of the enclosure.

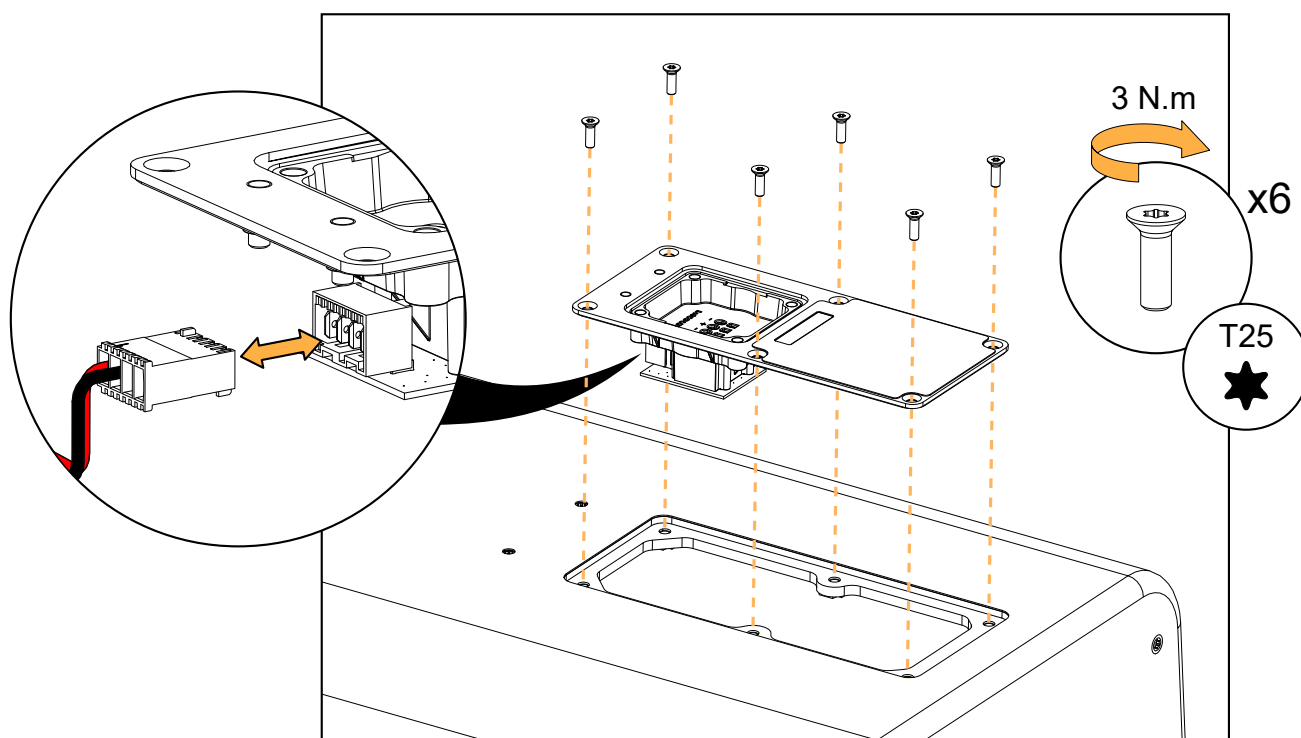

D/R - HF driver

Tools

- torque screwdriver
- T30 Torx bit

Repair kit

G03546 *

KR compression driver 3" A15i

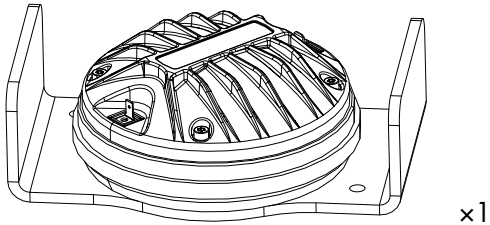

D101593

3" HF driver assembly - 8 Ω

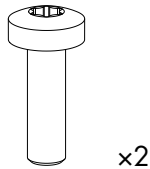

S100094

M6x20 Torx



* The screws and fasteners are also provided in the G03545 (KR diaphragm 3" A15i).

Prerequisite

Connector plate removed.

See [Connector plate](#) (p.117).

Exploded view



For safety reasons, always use the new screws and spare parts provided in the KR.
If no new screws are available, use blue threadlocker.

Carefully disconnect the cables before removing the driver assembly.

Use the positive (red) connector as a reference point to position the driver assembly.

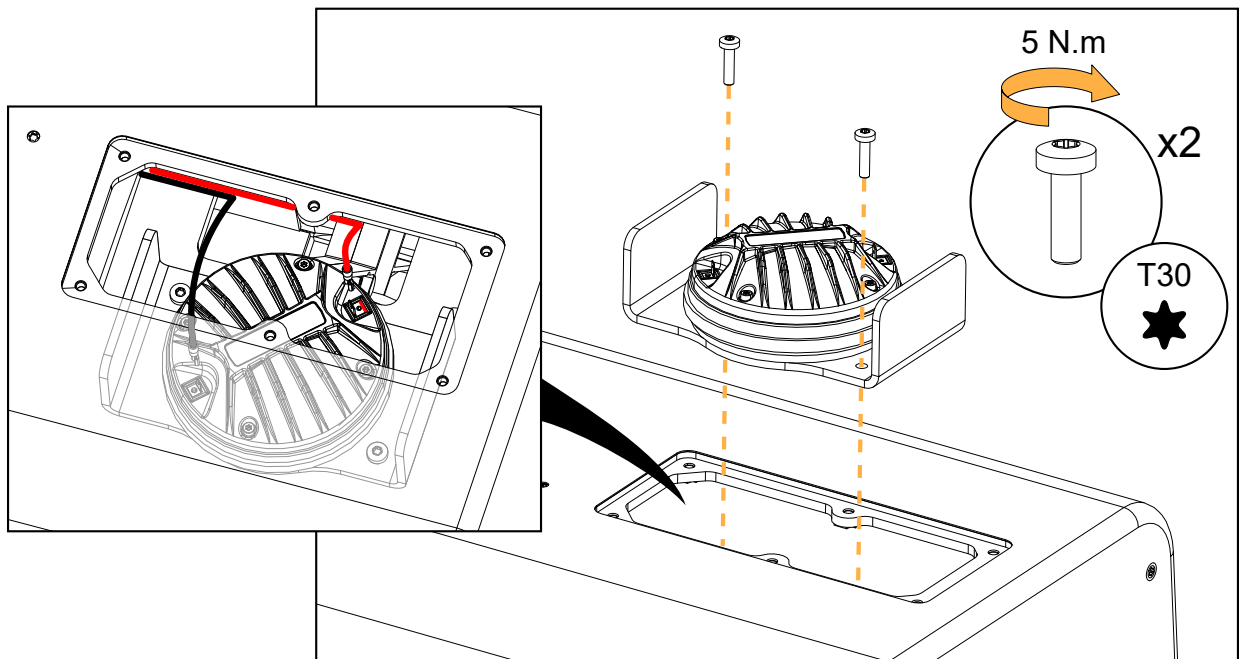

D/R - HF diaphragm

Tools

- torque screwdriver
- T20 Torx bit
- 3 mm hex bit
- compressed air blower

Consumables

- double face adhesive tape

Repair kit

G03545

KR diaphragm 3" A15i

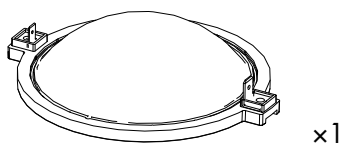

17581

diaphragm assembly (with 2 shims)

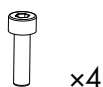

S100082

M4x14 hex

Prerequisite

Connector plate removed.

HF driver removed from the cabinet.

The driver is placed on a flat surface in a dust-free environment.

See [Connector plate](#) (p.117).

See [HF driver](#) (p.118).

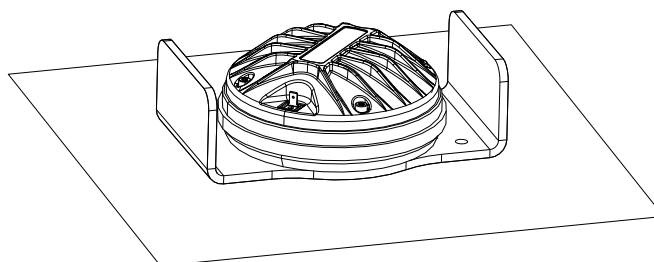

Disassembly

Procedure

1. Remove the four screws securing the cover.
Use the T20 Torx bit.
2. Remove the cover.
3. Carefully remove the diaphragm.
4. If there are shims on the dome, carefully remove them.
Take note of how many and what kind of shims are present.

Reassembly

About this task



For safety reasons, always use the new screws and spare parts provided in the KR.

Procedure

1. Clean the dome and the air gap.



Make sure the air gap is perfectly clean before reassembly.

Use a blower or double face adhesive to remove any particle.

2. Place the same kind and number of shims that were initially present.

3. Carefully place the diaphragm, using the positive (red) connector as reference point.

4. Position the cover and turn it to align it with the screw holes.



Gradually tighten the screws following a star pattern.

5. Secure the cover using four S100082 screws.

Use the 3 mm hex bit. Set the torque to 3.5 Nm.

What to do next

Perform the [Acoustical check](#) (p.55) procedures.

A15i Wide

Introduction

This section contains the following maintenance procedures:

- [Grill](#) (p.122)
- [Fin](#) (p.123)
- [LF speaker](#) (p.124)
- [Connector plate](#) (p.125)
- [HF driver](#) (p.126)
- [HF diaphragm](#) (p.127)

For advanced maintenance, contact your L-Acoustics representative.

Exploded view

In order to operate, follow the order outlined here. Each assembly refers to the corresponding Disassembly/Reassembly (D/R) procedure and the necessary repair kit.

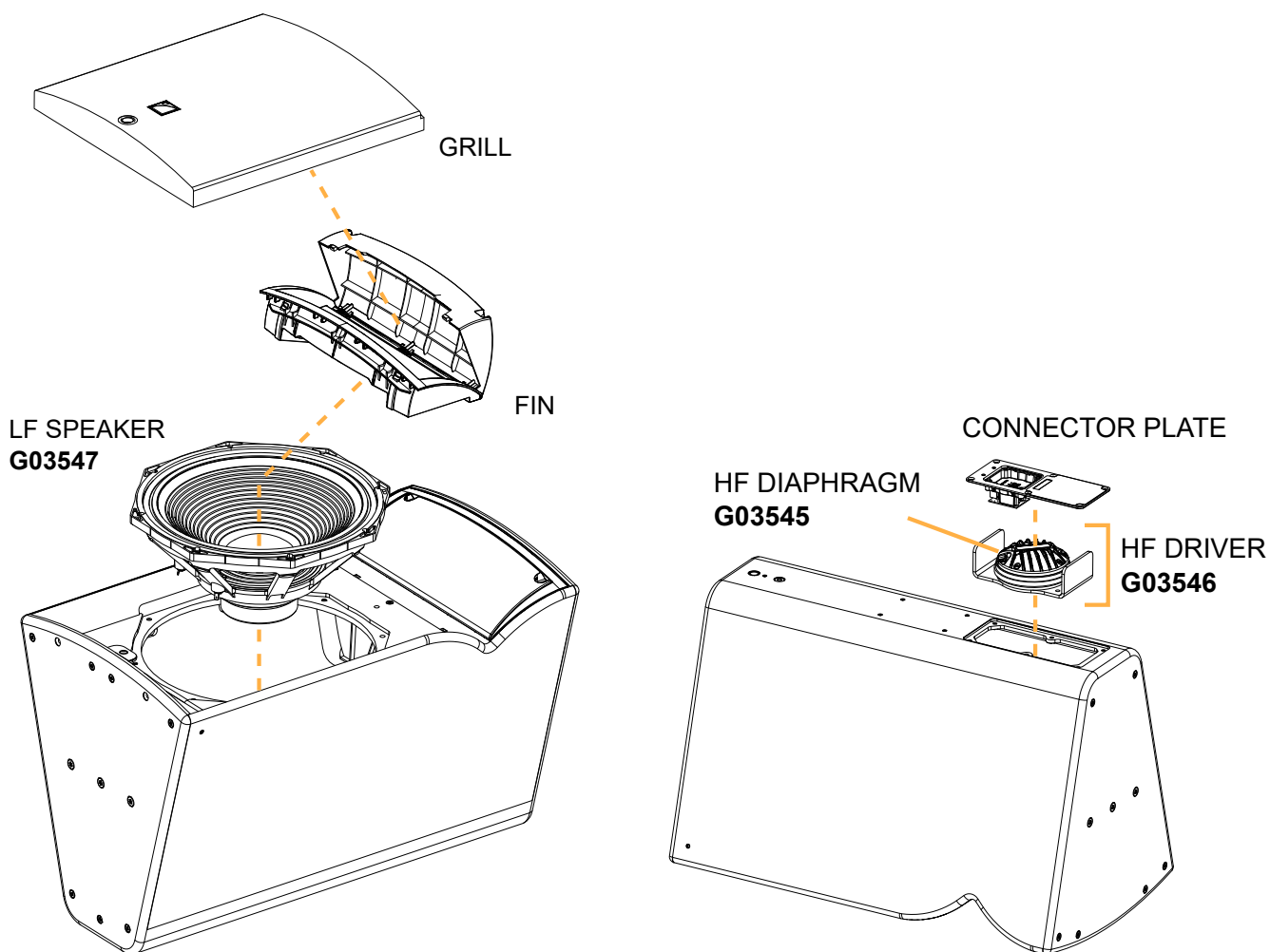

Disassembly and reassembly procedures

D/R - Grill

Tools

- torque screwdriver
- T30 Torx bit

Repair kit

G03547

KR loudspeaker 15" A15i

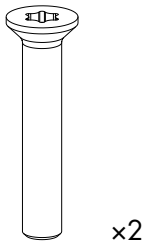

S221

M6x35 Torx

Exploded view

-  For safety reasons, always use the new screws and spare parts provided in the KR.
If no new screws are available, use blue threadlocker.

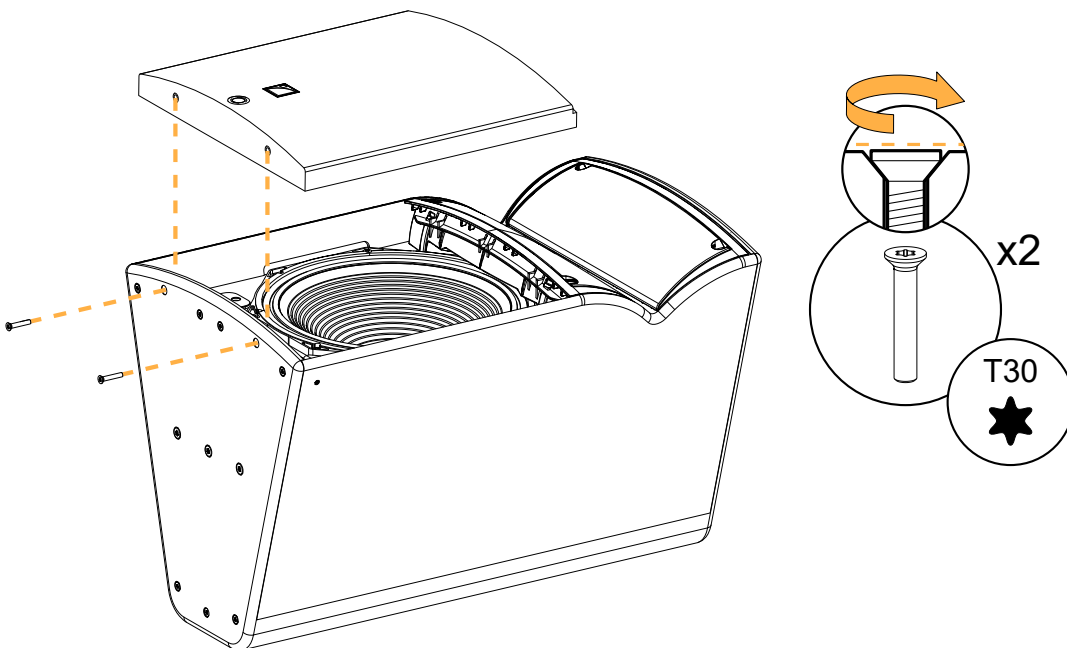

D/R - Fin

Tools

- torque screwdriver
- T30 Torx bit
- flat plastic tool

Repair kit

G03547

KR loudspeaker 15" A15i

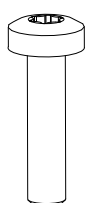

x5

S100143

M6x25 Torx

Prerequisite

Grill removed.

See [Grill](#) (p.122).

Exploded view



For safety reasons, always use the new screws and spare parts provided in the KR.
If no new screws are available, use blue threadlocker.



Use a flat tool made of **smooth plastic** to avoid scratching the fins.

With the flat tool, unhook the fin clips one by one.

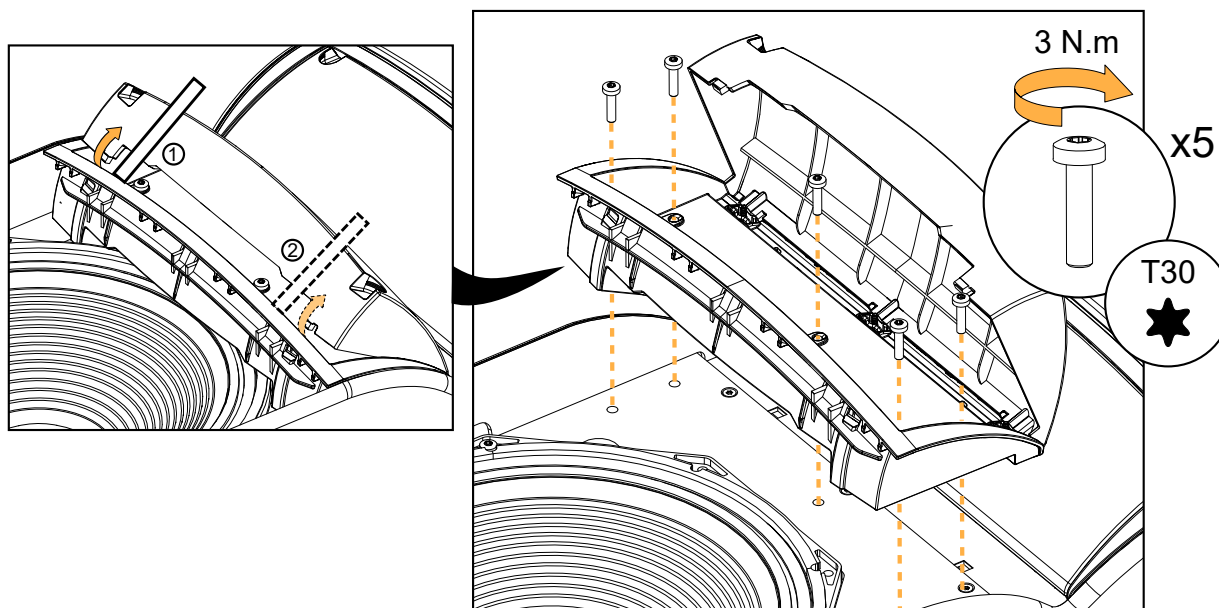

D/R - LF speaker

Tools

- torque screwdriver
- T30 Torx bit

Repair kit

G03547

KR loudspeaker 15" A15i

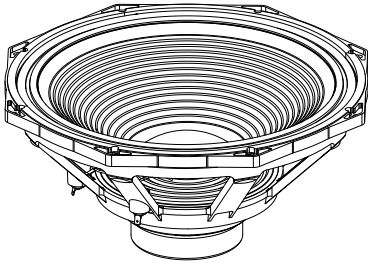

x1

17873

15" LF speaker - 8 Ω (with gasket)

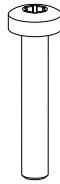

x8

S247

M6x35 Torx

Prerequisite

Grill removed.

See [Grill](#) (p.122).

Fin removed.

See [Fin](#) (p.123).

Exploded view



For safety reasons, always use the new screws and spare parts provided in the KR.
If no new screws are available, use blue threadlocker.

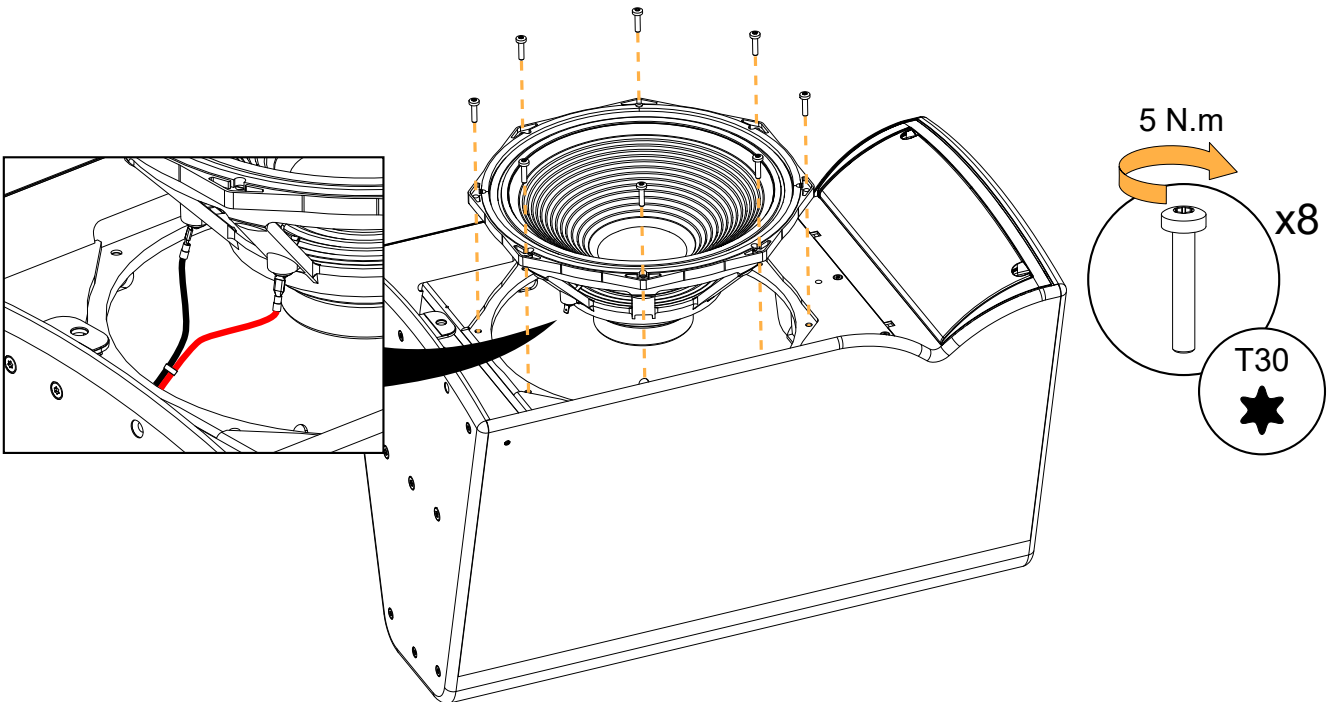

What to do next

Perform the [Acoustical check](#) (p.55) procedures.

D/R - Connector plate

Tools

- torque screwdriver
- T25 Torx bit
- flat tool

Repair kits

G03546 - KR compression driver 3" A15i or

G03545 - KR diaphragm 3" A15i

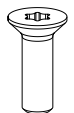

x6

S100086

M5x16 Torx

Exploded view



For safety reasons, always use the new screws and spare parts provided in the KR.
If no new screws are available, use blue threadlocker.



Gradually tighten the screws following a star pattern.

Use a flat tool as a lever to remove the connector plate.

Position the connector plate with the connectors towards the middle of the enclosure.

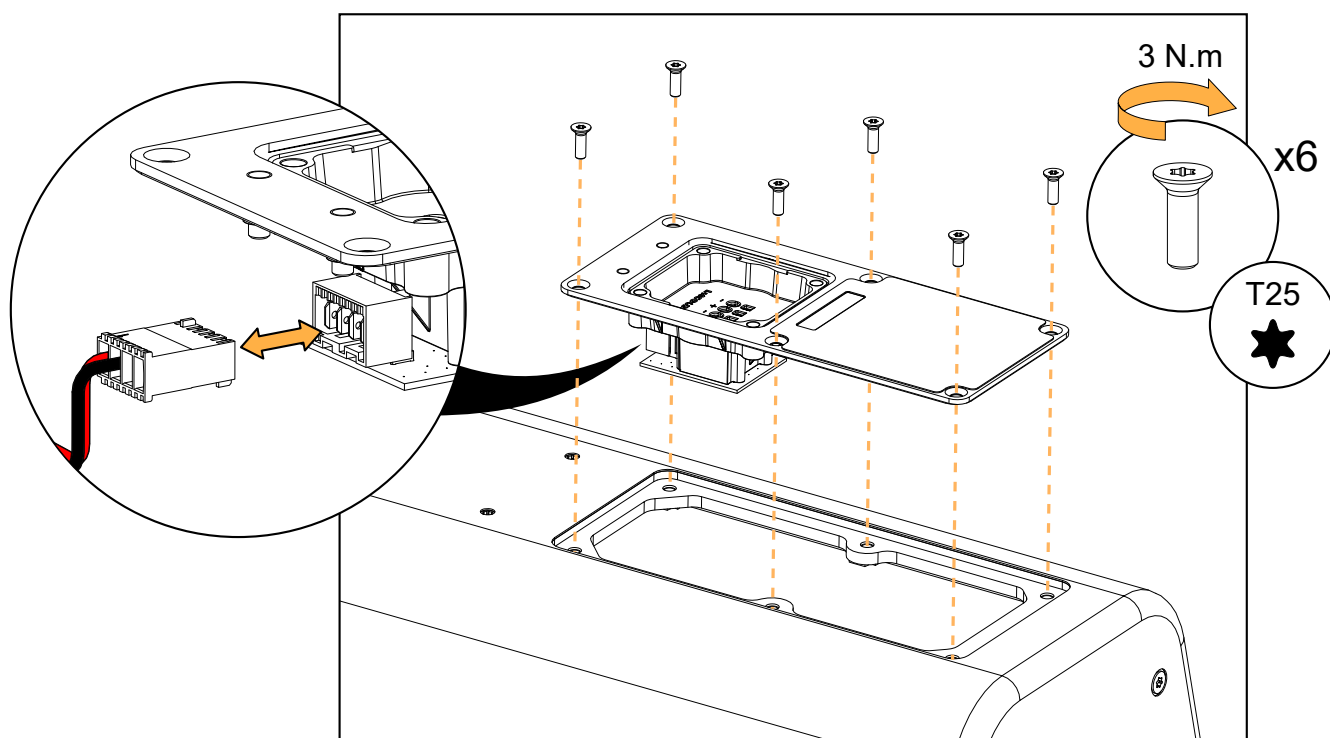

D/R - HF driver

Tools

- torque screwdriver
- T30 Torx bit

Repair kit

G03546 *

KR compression driver 3" A15i

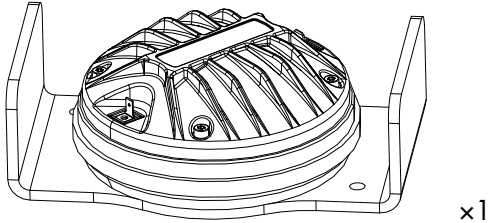

D101593

3" HF driver assembly - 8 Ω

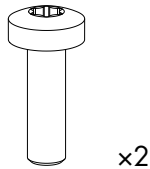

S100094

M6x20 Torx



* The screws and fasteners are also provided in the G03545 (KR diaphragm 3" A15i).

Prerequisite

Connector plate removed.

See [Connector plate](#) (p.125).

Exploded view



For safety reasons, always use the new screws and spare parts provided in the KR.
If no new screws are available, use blue threadlocker.

Carefully disconnect the cables before removing the driver assembly.

Use the positive (red) connector as a reference point to position the driver assembly.

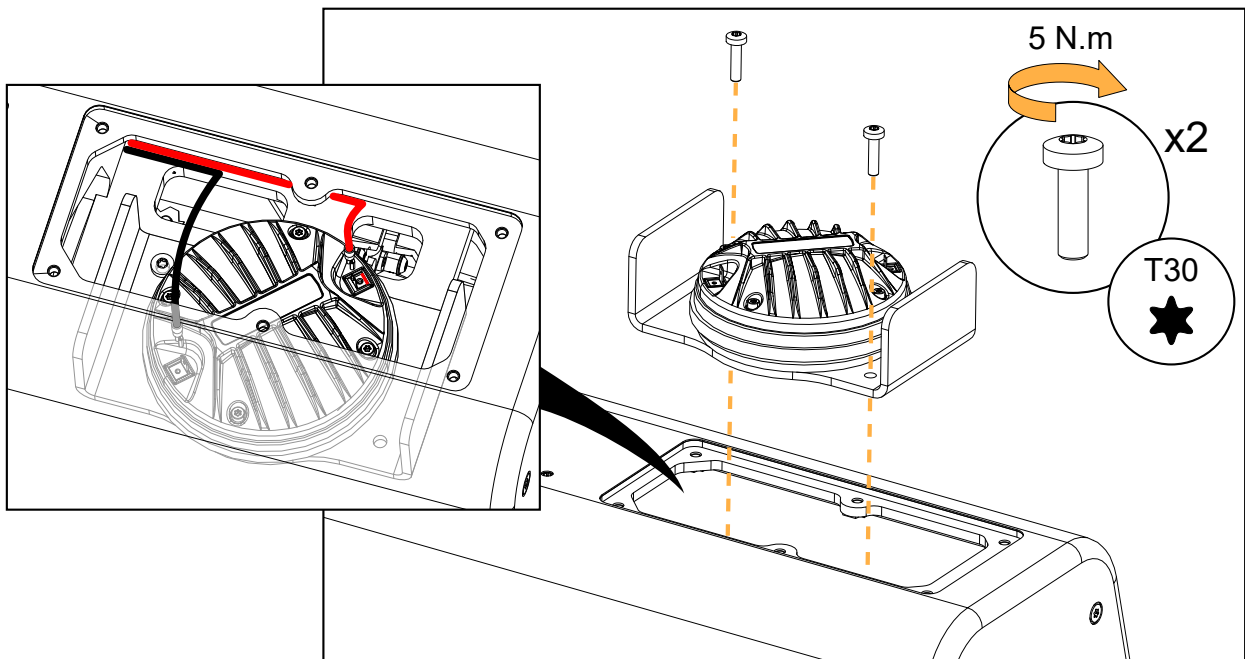

D/R - HF diaphragm

Tools

- torque screwdriver
- T20 Torx bit
- 3 mm hex bit
- compressed air blower

Consumables

- double face adhesive tape

Repair kit

G03545

KR diaphragm 3" A15i

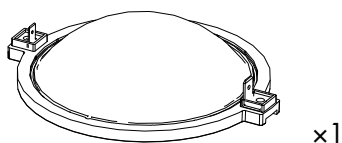

x1

17581

diaphragm assembly (with 2 shims)



x4

S100082

M4x14 hex

Prerequisite

Connector plate removed.

HF driver removed from the cabinet.

The driver is placed on a flat surface in a dust-free environment.

See [Connector plate](#) (p.125).

See [HF driver](#) (p.126).

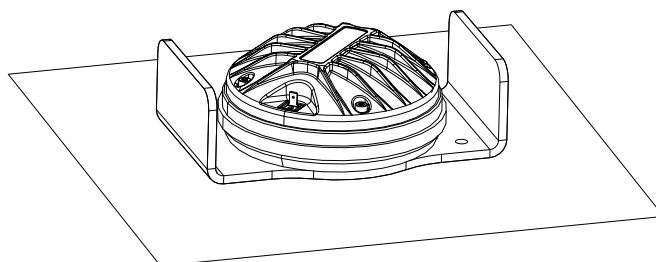

Disassembly

Procedure

1. Remove the four screws securing the cover.
Use the T20 Torx bit.
2. Remove the cover.
3. Carefully remove the diaphragm.
4. If there are shims on the dome, carefully remove them.
Take note of how many and what kind of shims are present.

Reassembly

About this task



For safety reasons, always use the new screws and spare parts provided in the KR.

Procedure

1. Clean the dome and the air gap.



Make sure the air gap is perfectly clean before reassembly.

Use a blower or double face adhesive to remove any particle.

2. Place the same kind and number of shims that were initially present.
3. Carefully place the diaphragm, using the positive (red) connector as reference point.
4. Position the cover and turn it to align it with the screw holes.



Gradually tighten the screws following a star pattern.

5. Secure the cover using four S100082 screws.
Use the 3 mm hex bit. Set the torque to 3.5 Nm.

What to do next

Perform the [Acoustical check](#) (p.55) procedures.

KS21i

Introduction

This section contains the following maintenance procedures:

- [Grill](#) (p.130)
- [Fixing bars](#) (p.131)
- [LF speaker](#) (p.132)

For advanced maintenance, contact your L-Acoustics representative.

KS21i exploded view

In order to operate, follow the order outlined here. Each assembly refers to the corresponding Disassembly/Reassembly (D/R) procedure and the necessary repair kit.

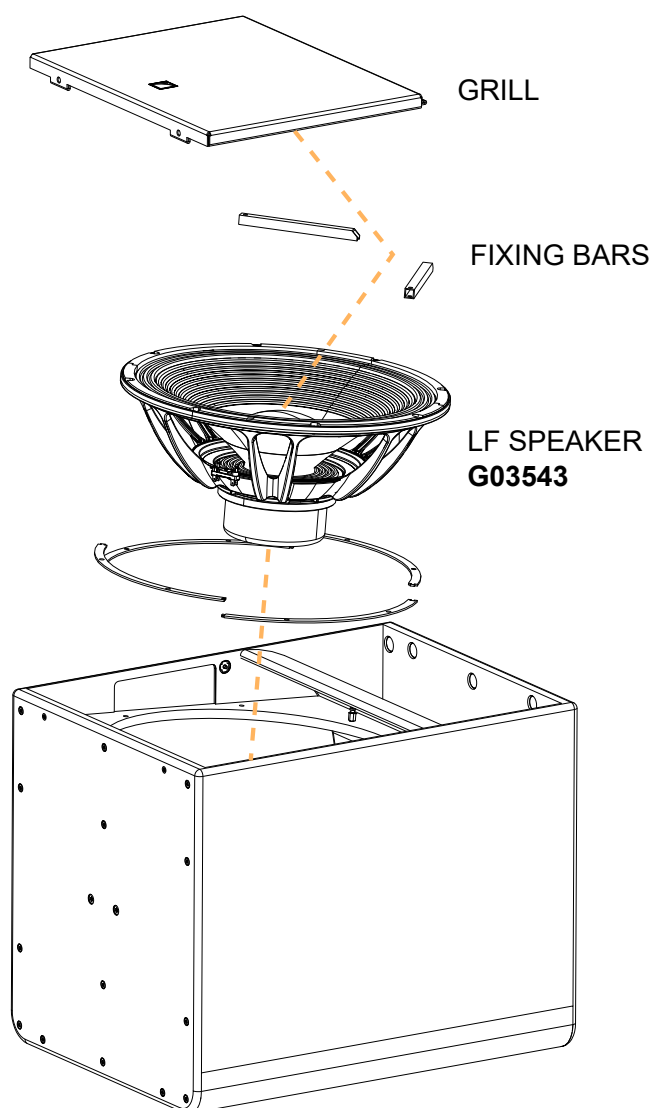

Disassembly and reassembly procedures

D/R - Grill

Tools

- torque screwdriver
- T30 Torx bit

Repair kit

G03543

KR loudspeaker 21" KS21i

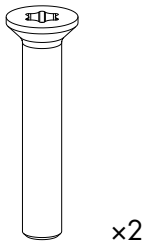

S221

M6x35 Torx

Exploded view



For safety reasons, always use the new screws and spare parts provided in the KR.
If no new screws are available, use blue threadlocker.

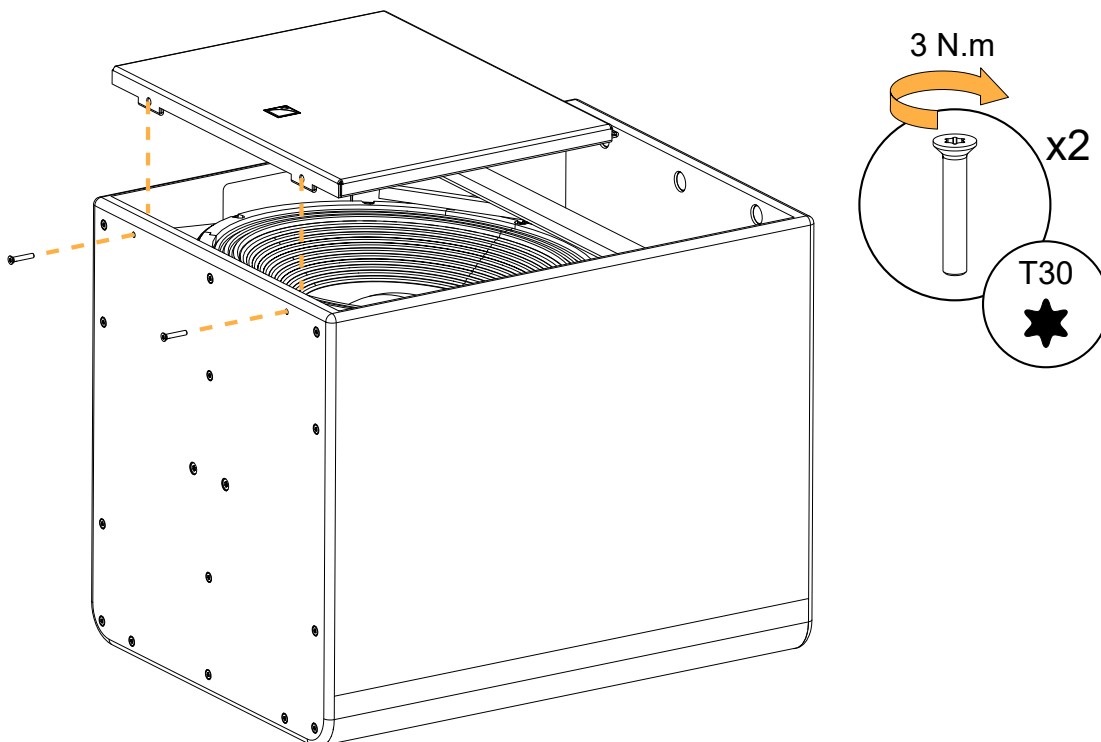

D/R - Fixing bars

Tools

- torque screwdriver
- T30 Torx bit

Repair kit

G03543

KR loudspeaker 21" KS21i

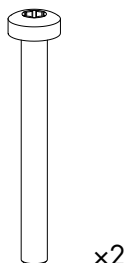

S253

M6 x 55 Torx

Prerequisite

Grill removed.

See [Grill](#) (p.130).

Exploded view



For safety reasons, always use the new screws and spare parts provided in the KR.
If no new screws are available, use blue threadlocker.

Slide the fixing bars under the vent panel to attach them to the studs, then secure them with the screws.

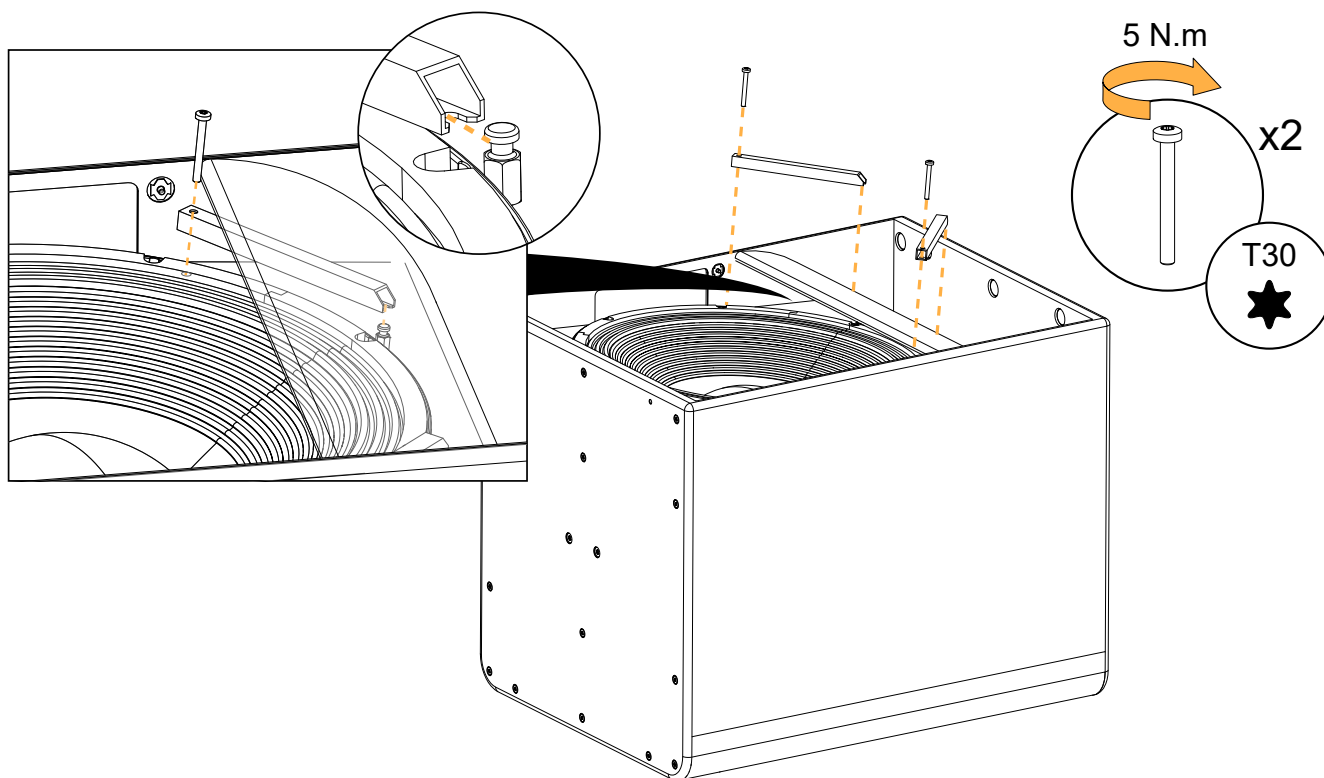

D/R - LF speaker

Tools

- torque screwdriver
- T30 Torx bit

Repair kit

G03543

KR loudspeaker 21" KS21i

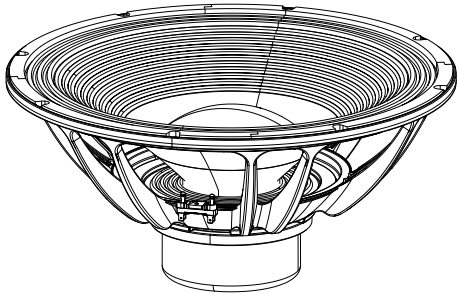

17945
21" LF speaker - 8 Ω

x1

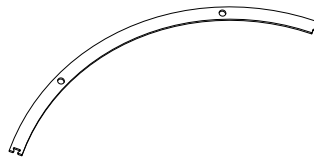

102157
21" speaker gasket

x4



S247
M6x35 Torx

x6

Prerequisite

Grill removed.

See [Grill](#) (p.130).

Exploded views



For safety reasons, always use the new screws and spare parts provided in the KR.
If no new screws are available, use blue threadlocker.

Tilt the speaker to remove it from the cabinet. Carefully disconnect the cables.

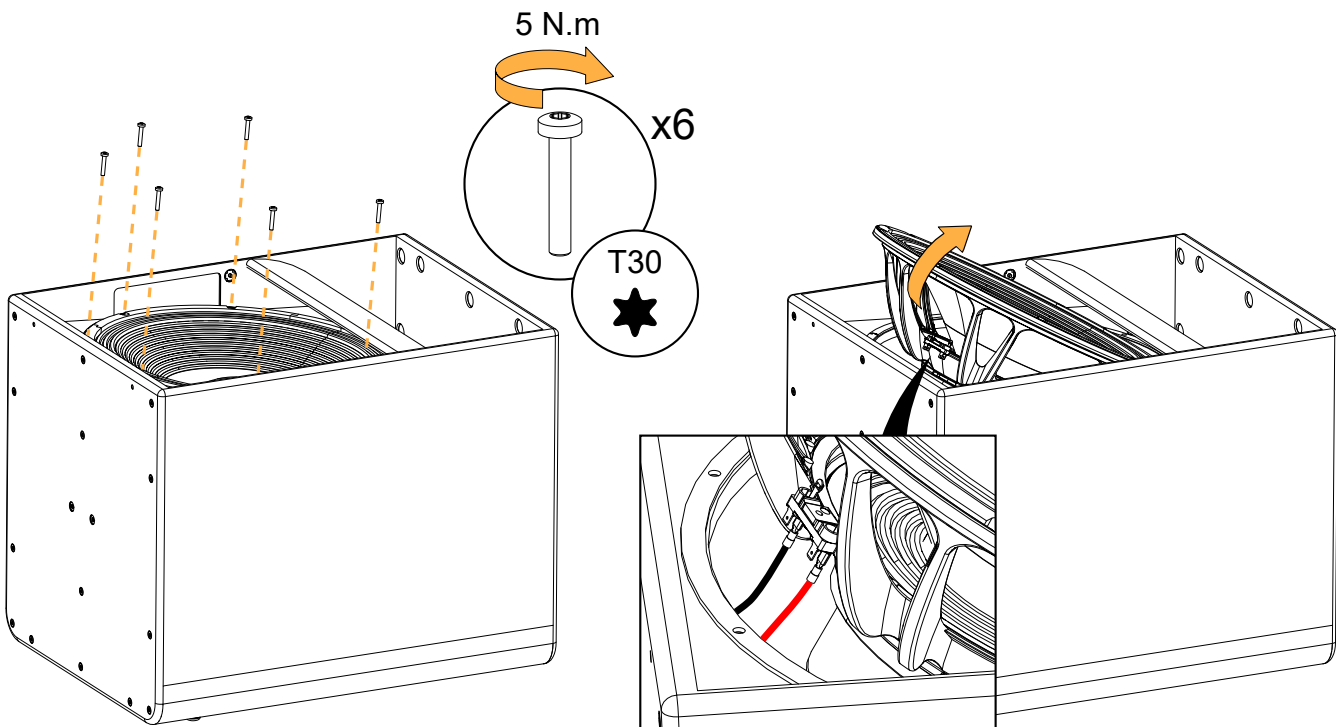

i If the speaker gasket is damaged, remove and replace it.

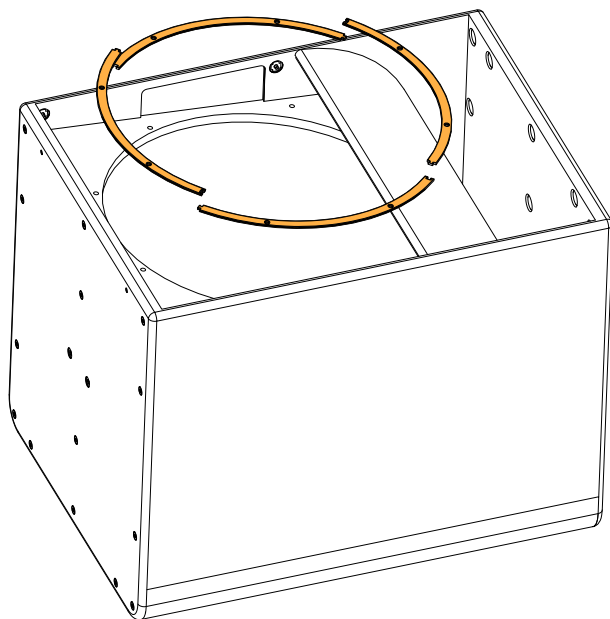

Specifications

A15i Focus specifications

Description	2-way passive constant curvature WST® 10° enclosure: 15" LF + 3" HF diaphragm (installation version), amplified by LA2Xi / LA4X / LA8 / LA12X
Usable bandwidth (-10 dB)	41 Hz - 20 kHz ([A15])
Maximum SPL ¹	144 dB ([A15]) with LA2Xi (bridge mode) / LA4X / LA8 / LA12X 139 dB ([A15]) with LA2Xi
Nominal directivity (-6 dB)	enclosure: 10° L-Fins: 70° / 110° symmetric or 90° asymmetric (-6 dB)
Transducers	LF: 1 × 15" cone driver HF: 1 × 3" diaphragm compression driver, neodymium
Acoustical load	LF: bass-reflex, L-Vents HF: DOSC waveguide, L-Fins
Nominal impedance	8 Ω
Connectors	1 × 4-point terminal block with push-in connection
Rigging and handling	external rigging kits M6 inserts for rigging plates M8 inserts for A-U15i 4 M6 inserts for rigging accessory 1 DIN580-compatible M8 threaded insert
Weight (net)	32 kg / 71 lb
Cabinet	premium grade Baltic beech and birch plywood
Front	coated steel grill acoustically neutral 3D fabric
Finish	dark grey brown Pantone 426 C pure white RAL 9010 custom RAL code on special order
IP	IP55

¹ Peak level measured at 1 m under free field conditions using pink noise with crest factor 4 (preset specified in brackets).

A15i Focus dimensions

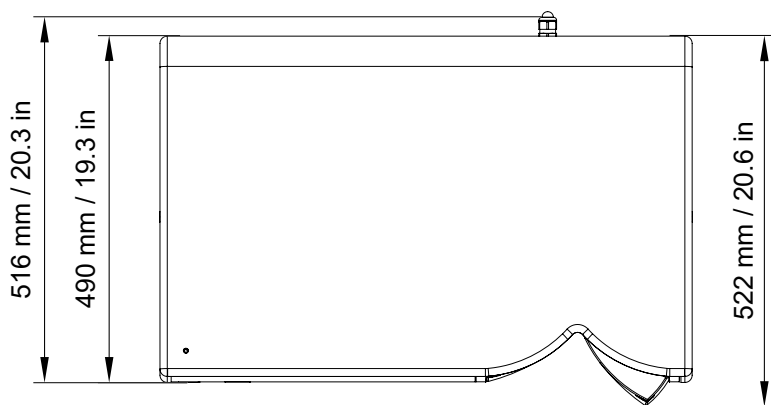
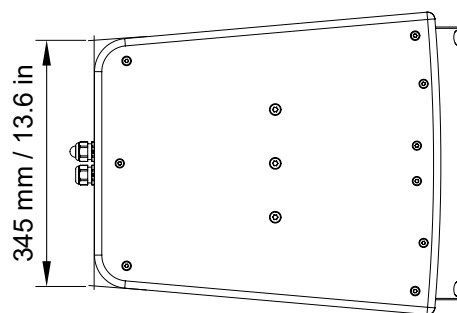
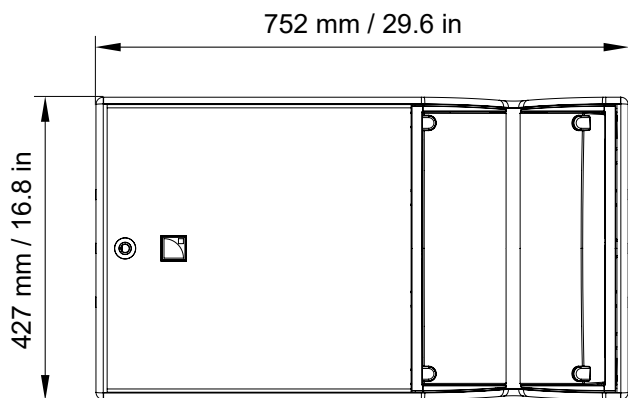

A15i Wide specifications

Description	2-way passive constant curvature WST® 30° enclosure: 15" LF + 3" HF diaphragm (installation version), amplified by LA2Xi / LA4X / LA8 / LA12X
Usable bandwidth (-10 dB)	42 Hz - 20 kHz ([A15])
Maximum SPL ¹	141 dB ([A15]) with LA2Xi (bridge mode) / LA4X / LA8 / LA12X 136 dB ([A15]) with LA2Xi
Nominal directivity (-6 dB)	enclosure: 30° L-Fins: 70° / 110° symmetric or 90° asymmetric (-6 dB)
Transducers	LF: 1 × 15" cone driver HF: 1 × 3" diaphragm compression driver, neodymium
Acoustical load	LF: bass-reflex, L-Vents HF: DOOSC waveguide, L-Fins
Nominal impedance	8 Ω
Connectors	1 × 4-point terminal block with push-in connection
Rigging and handling	external rigging kits M6 inserts for rigging plates M8 inserts for A-U15i 4 M6 inserts for rigging accessory 1 DIN580-compatible M8 threaded insert
Weight (net)	29 kg / 64 lb
Cabinet	premium grade Baltic beech and birch plywood
Front	coated steel grill acoustically neutral 3D fabric
Finish	dark grey brown Pantone 426 C pure white RAL 9010 custom RAL code on special order
IP	IP55

¹ Peak level measured at 1 m under free field conditions using pink noise with crest factor 4 (preset specified in brackets).

A15i Wide dimensions

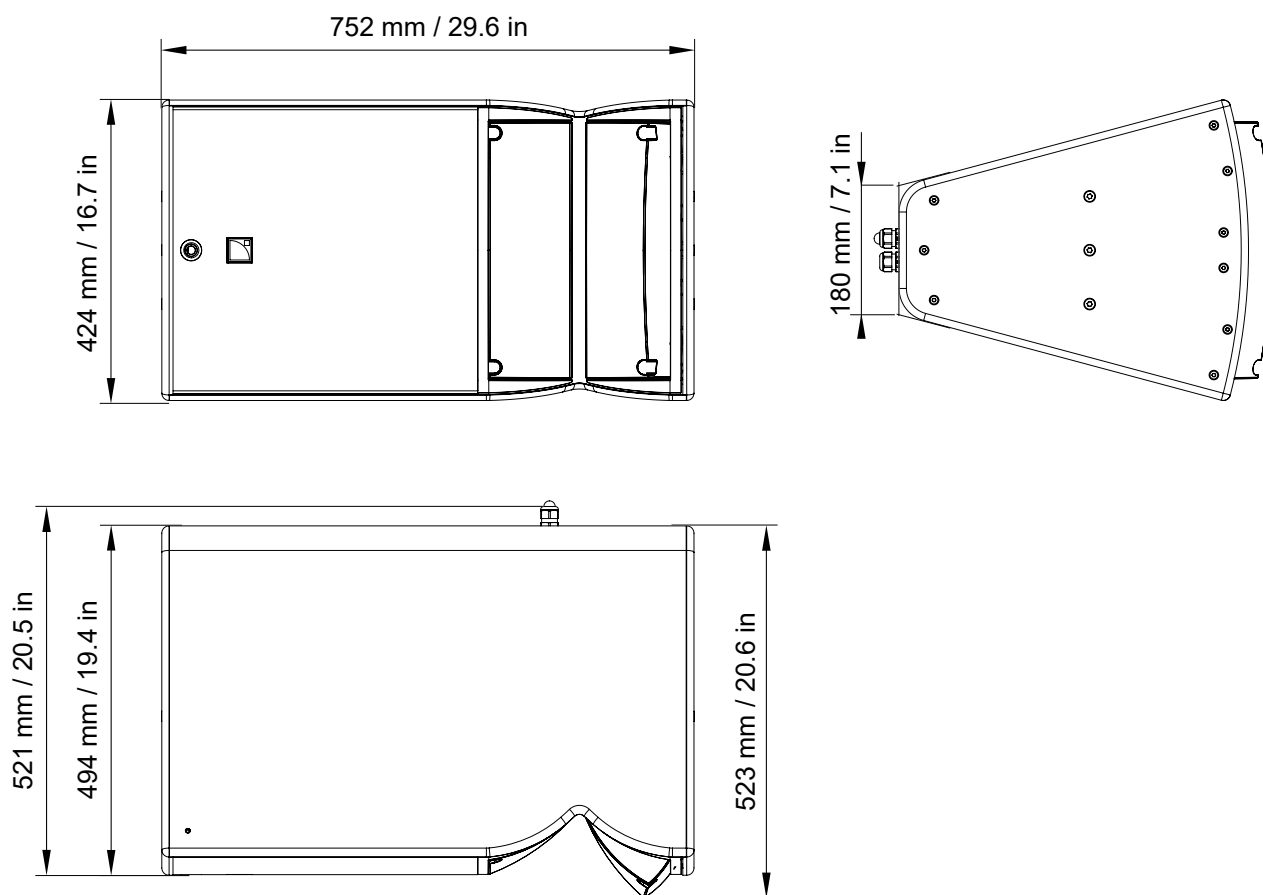

KS21i specifications

Description	High power compact subwoofer: 1 x 21" (installation version), amplified by LA2Xi / LA4X / LA8 / LA12X
Low frequency limit (-10 dB)	31 Hz ([KS21_100])
Maximum SPL ¹	138 dB ([KS21_100]) with LA2Xi (bridge mode) / LA4X / LA8 / LA12X 131 dB ([KS21_100]) with LA2Xi
Nominal directivity (-6 dB)	standard or cardioid configuration
Transducers	1 x 21" neodymium cone driver
Acoustical load	bass-reflex, L-Vents
Nominal impedance	8 Ω
Connectors	1 x 4-point terminal block with push-in connection
Rigging and handling	external rigging kits M6 inserts for rigging plates M8 inserts for A-U15i 1 DIN580-compatible M8 threaded insert
Weight (net)	46 kg / 101 lb
Cabinet	premium grade Baltic beech and birch plywood
Front	coated steel grill acoustically neutral 3D fabric
Finish	dark grey brown Pantone 426 C pure white RAL 9010 custom RAL code on special order
IP	IP55

¹ Peak level at 1 m under half space conditions using pink noise with crest factor 4 (preset specified in brackets).

KS21i dimensions

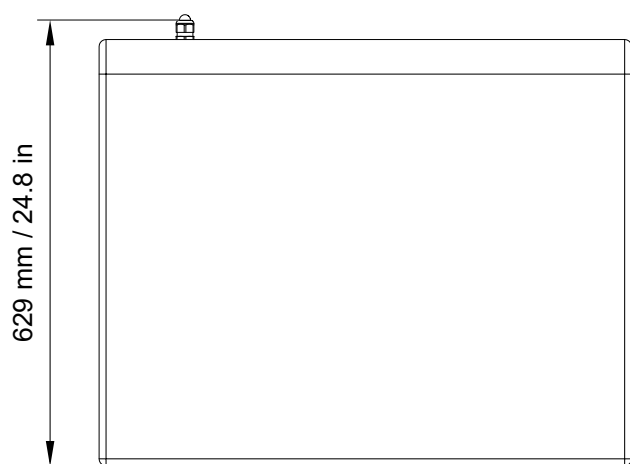
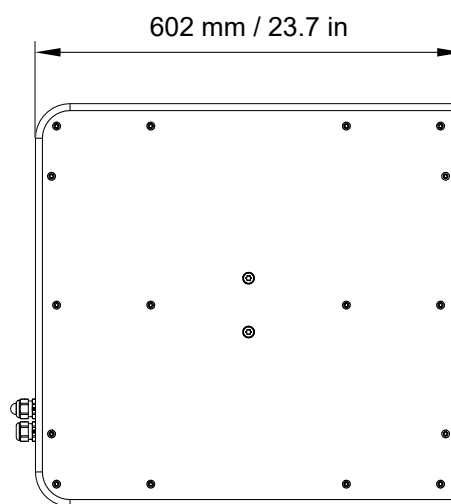
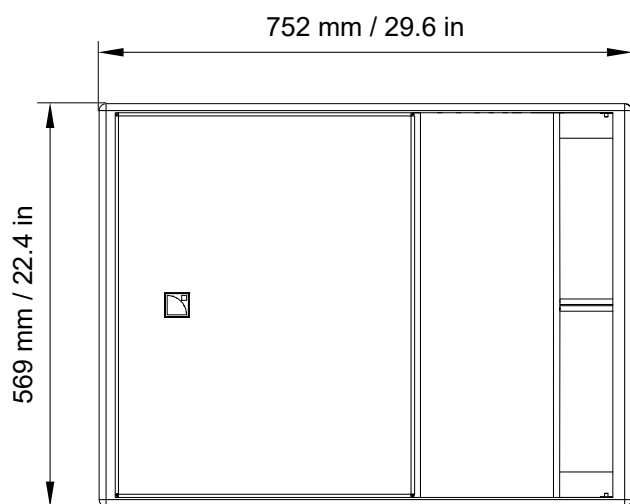

A-U15i specifications

Description	U-bracket for A15i and KS21i
Weight (net)	4.9 kg / 11 lb
Material	high grade steel with anti-corrosion coating

A-U15i dimensions

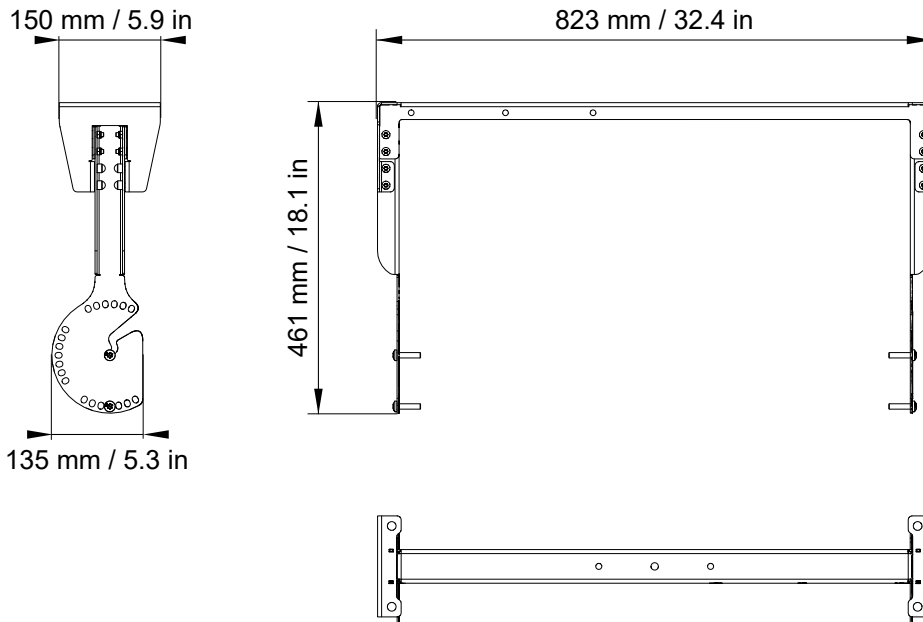

A15i-BUMP specifications

Description	Flying frame for vertical deployment of A15i and KS21i
Weight (net)	16 kg / 35 lb
Material	high grade steel with anti-corrosion coating

A15i-BUMP dimensions

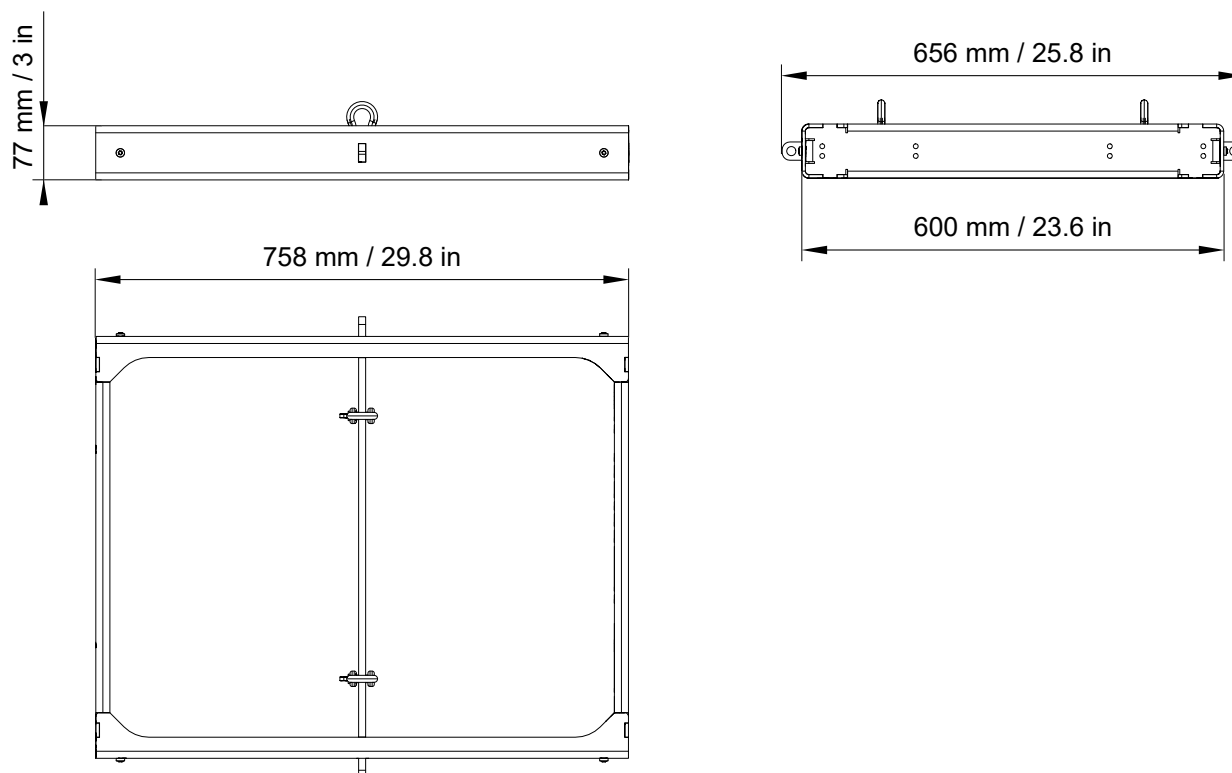

A15i-RIGBAR specifications

Description	Rigging bar and pullback for A15i and KS21i
Weight (net)	5.6 kg / 12 lb
Material	high grade steel with anti-corrosion coating

A15i-RIGBAR dimensions

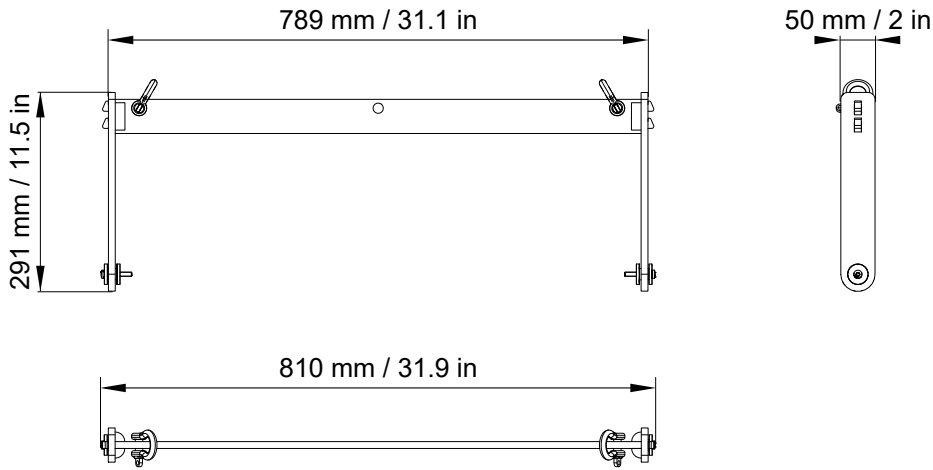

A15i-LIFT specifications

Description	Rigging element for horizontal deployment of A15i
Weight (net)	2.4 kg / 5.3 lb
Material	high grade steel with anti-corrosion coating

A15i-LIFT dimensions

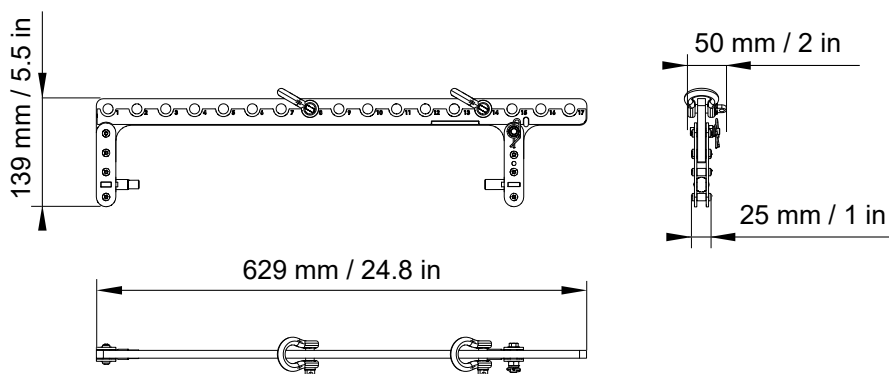

CLAMP250 specifications

Description	Clamp certified for 250 kg
Weight (net)	1.8 kg / 4 lb
Material	high grade steel with anti-corrosion coating

CLAMP250 dimensions

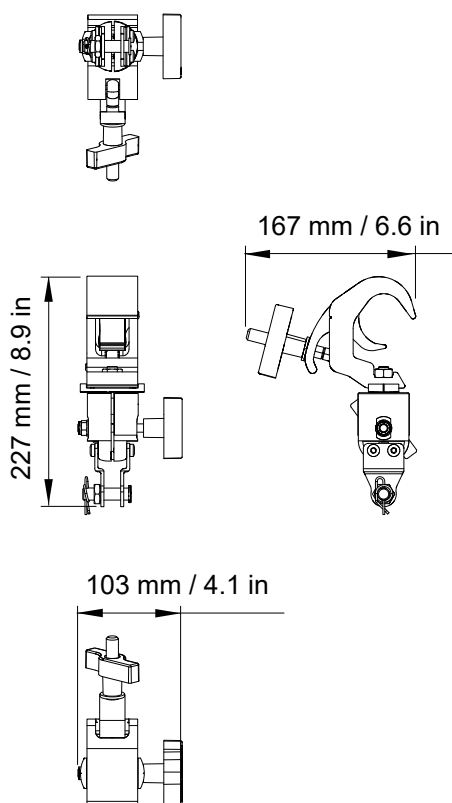

M-BARi specifications

Description	Extension bar for rigging frame (installation version)
Weight (net)	5 kg / 11 lb
Material	high grade steel with anti-corrosion coating

M-BARi dimensions

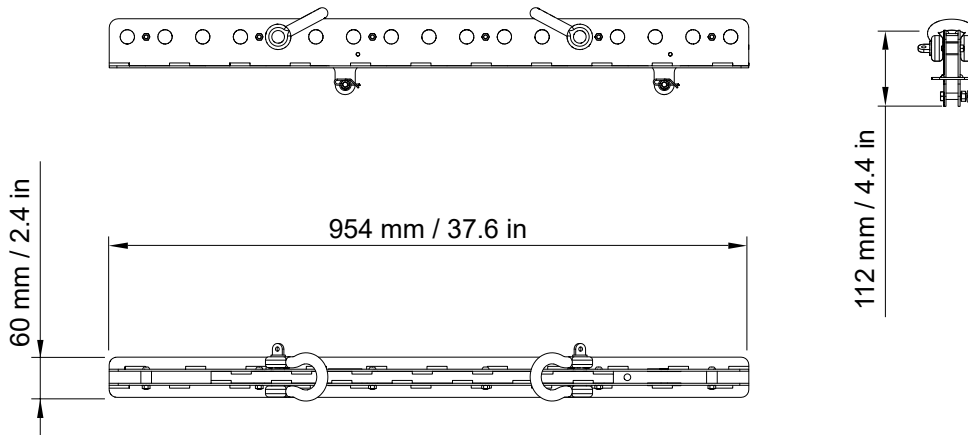

Ai-FIXBRACKET specifications

Description	Fastening bracket for A15i, A10i and KS21i
Weight (net)	0.45 kg / 1 lb
Material	high grade steel with anti-corrosion coating

Ai-FIXBRACKET dimensions

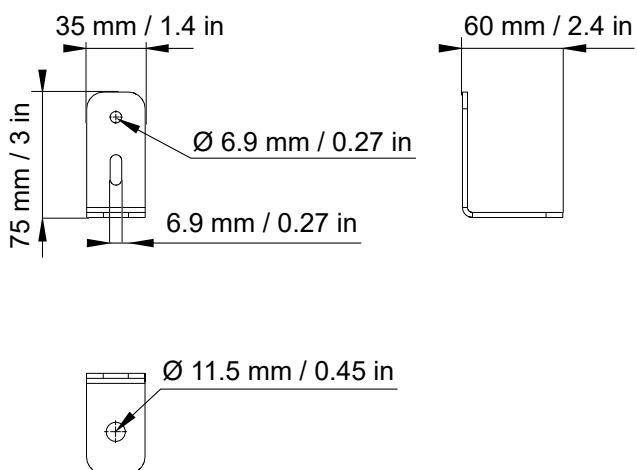

A15i-TILTBRACKET specifications

Description	Fastening bracket with angles for A15i
Weight (net)	0.85 kg / 1.9 lb
Material	high grade steel with anti-corrosion coating

A15i-TILTBRACKET dimensions

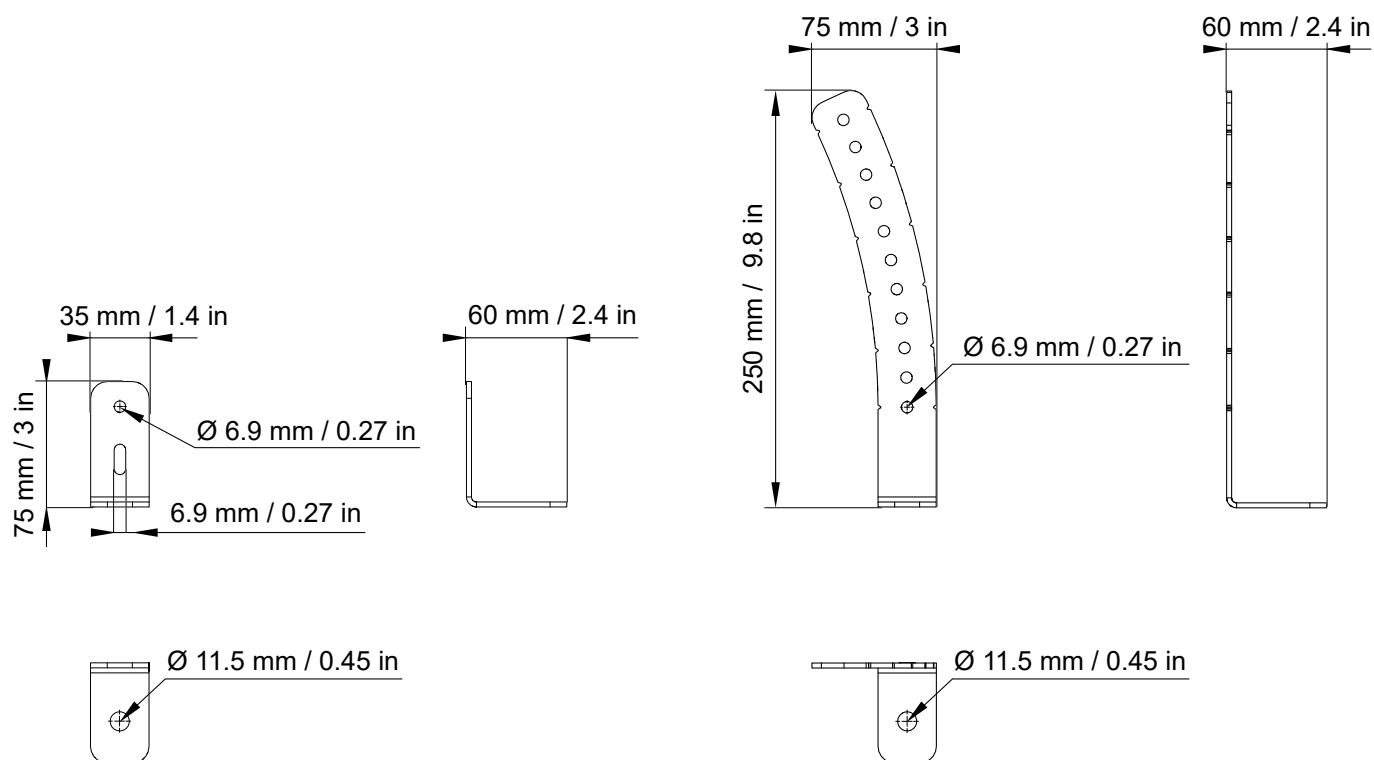

A15iFOCUS-SCREEN specifications

Description	Acoustically transparent front screen for A15i Focus
Weight (net)	2.9 kg / 6.4 lb
Materials	steel with anti-corrosion coating acoustically neutral 3D fabric

A15iFOCUS-SCREEN dimensions

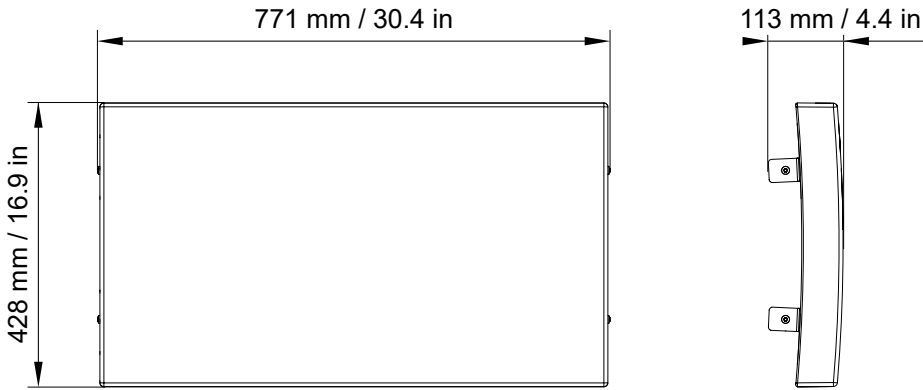

A15iWIDE-SCREEN specifications

Description	Acoustically transparent front screen for A15i Wide
Weight (net)	2.9 kg / 6.4 lb
Materials	steel with anti-corrosion coating acoustically neutral 3D fabric

A15iWIDE-SCREEN dimensions

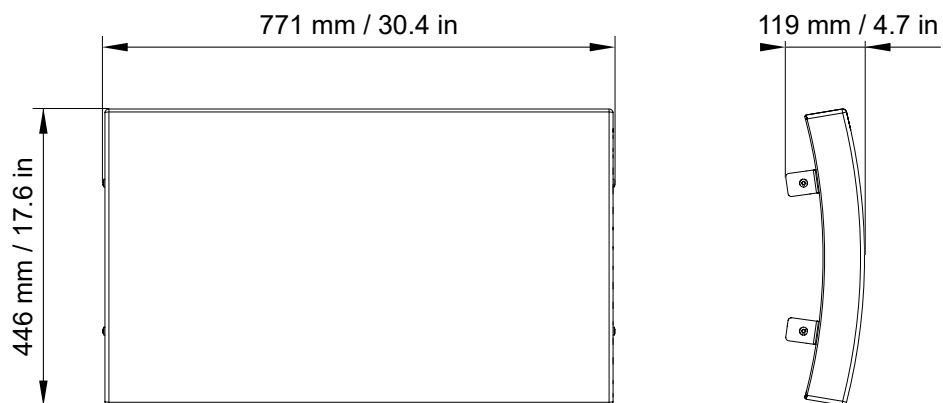

KS21i-SCREEN specifications

Description	Acoustically transparent front screen for KS21i
Weight (net)	3.1 kg / 6.8 lb
Materials	steel with anti-corrosion coating acoustically neutral 3D fabric

KS21i-SCREEN dimensions

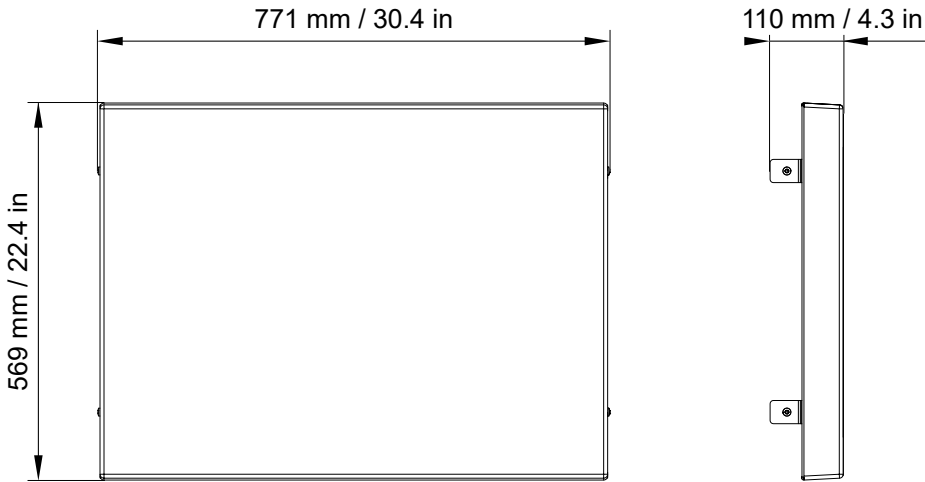

A15iFOCUS-SCREEN-LIFT specifications

Description	Acoustically transparent front screen for A15i Focus with A15i-LIFT
Weight (net)	2.9 kg / 6.4 lb
Materials	steel with anti-corrosion coating acoustically neutral 3D fabric

A15iFOCUS-SCREEN-LIFT dimensions

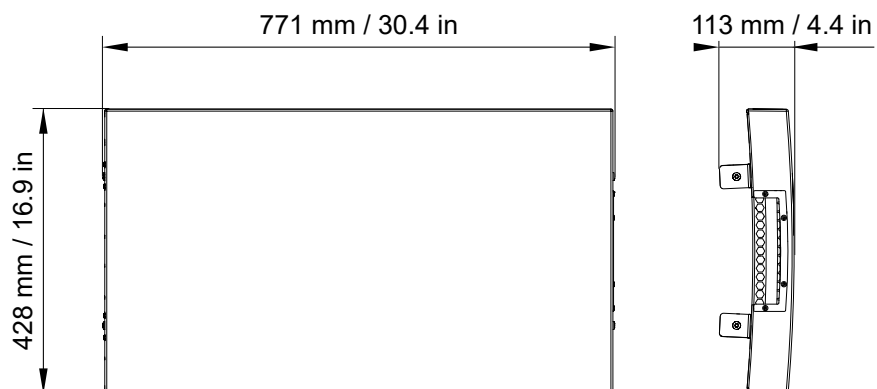

A15iWIDE-SCREEN-LIFT specifications

Description	Acoustically transparent front screen for A15i Wide with A15i-LIFT
Weight (net)	3 kg / 6.6 lb
Materials	steel with anti-corrosion coating acoustically neutral 3D fabric

A15iWIDE-SCREEN-LIFT dimensions

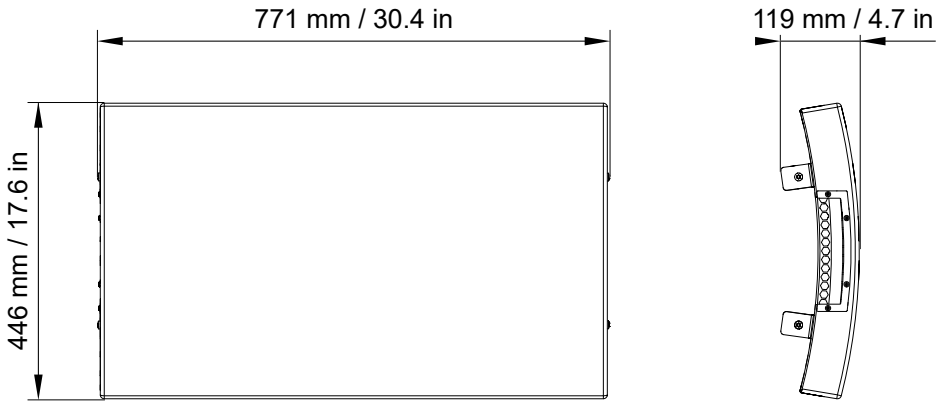

Authorized configurations with A15i-LIFT

Safety instructions

! Additional safety with A15i-LIFT

On each enclosure on which A15i-LIFT is secured, secure a DIN580 eye bolt to the dedicated insert to implement a secondary safety.

Use a shackle and a steel wire rope. Make sure the steel rope is as tensed as possible without bearing the load.

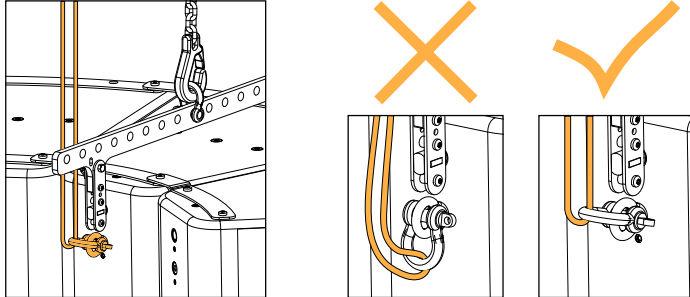

! A15i-LIFT quantity and position

Use one A15i-LIFT for up to three enclosures in the array.

Do not leave more than two adjacent enclosures unsupported.

Refer to [APPENDIX A: Authorized configurations with A15i-LIFT](#) (p.151).

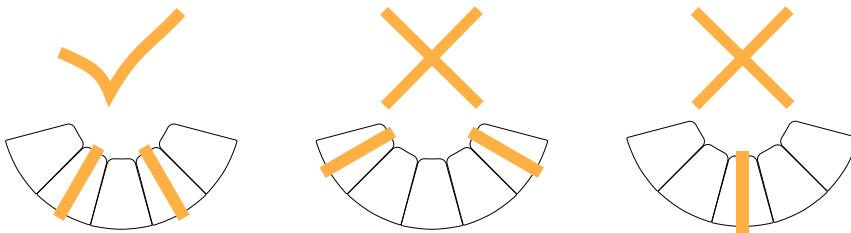

! A15i-LIFT pickup point

Select the same pickup point on each A15i-LIFT within an array of up to 6 enclosures.

For larger arrays, refer to [Radial arrays of 7 enclosures and more](#) (p.152).

! Risk of tilting

When using a single motor or a bridle, make sure the array is symmetrical.

! When using a third-party bridle, make sure the angle between the two chains does not exceed 60°.

i Hybrid configurations

Either A15i Wide, A15i Focus or a combination of both can be used as illustrated.

Radial arrays of 1 to 6 enclosures

Refer to the illustrations to distribute the A15i-LIFT bars on the array.

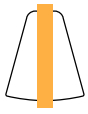

1 enclosure :
1 A15i-LIFT



2 enclosures :
2 A15i-LIFT

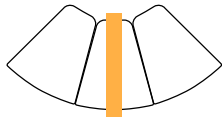

3 enclosures :
1 A15i-LIFT

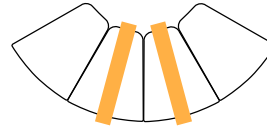

4 enclosures : 2 A15i-LIFT

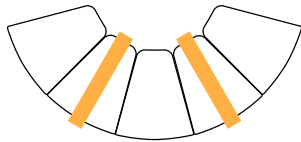

5 enclosures : 2 A15i-LIFT

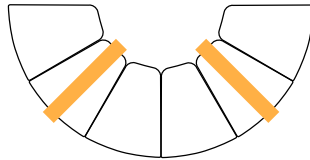

6 enclosures : 2 A15i-LIFT

Radial arrays of 7 enclosures and more

Refer to the illustrations to distribute the A15i-LIFT bars on the array.

⚠ In radial arrays of 7 enclosures and more, make sure the site angle is 0°.
Position the pickup points so that the center of gravity is in the middle of the array.

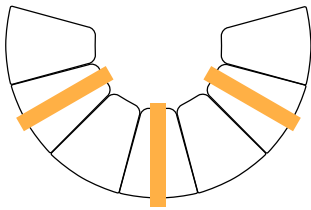

7 enclosures : 3 A15i-LIFT

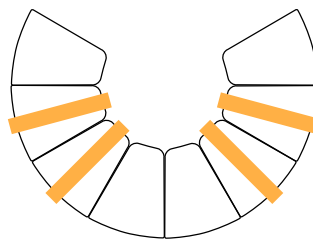

8 enclosures : 4 A15i-LIFT

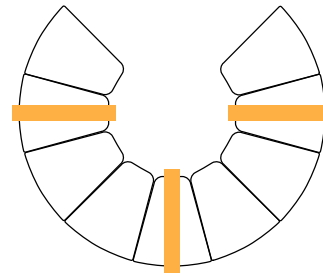

9 enclosures : 3 A15i-LIFT

Array setup information

type	number of enclosures	number of motors	pickup point for 0° site angle
A15i Focus	7	3	—
	8	2 (2 bridles)	8
	9	3	—
A15i Wide	7	3	—
	8	2 (2 bridles)	13
	9	3	—

Configurations with A-U15i

A15i Wide/Focus

Inserts for U-bracket

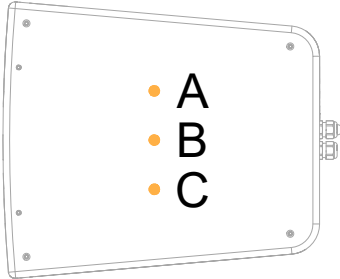

configuration	number of enclosures	reference axis	coverage	resolution	holes used on enclosure	
					B+C (for -30° to +30° in 10° steps)	A+B (for -25° to +25° in 10° steps)
	1	0° (site)	-30° / +30°	5°	B+C (for -30° to +30° in 10° steps)	A+B (for -25° to +25° in 10° steps)
	2	0° (site)	-30° / +30°	10°	B+C	
	1	0° (site)	-25° / +25°	10°	B+C	
	1	-90° (site)	-30° / +30°	10°	B+C	
	1	0° (site)	-30° / +30°	10°	B+C	
	2	0° (site)	Refer to coverage table (p.155)	10°	B+C	

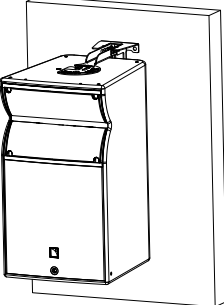
configuration	number of enclosures	reference axis	coverage	resolution	holes used on enclosure	
	1	0° (azimuth)	-30° / +30°	10°	B+C (for -30° to +30° in 10° steps)	A+B (for -25° to +25° in 10° steps)

KS21i

Inserts for U-bracket

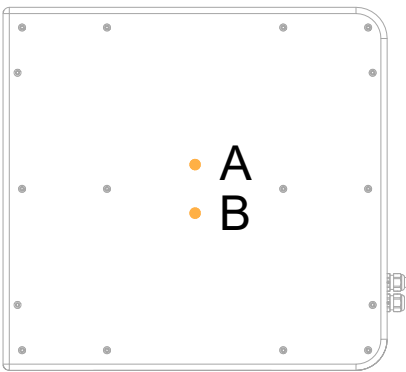

Both holes are used in every configuration.

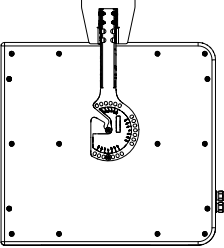
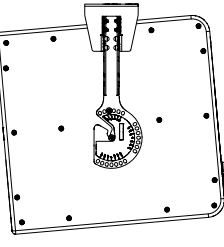
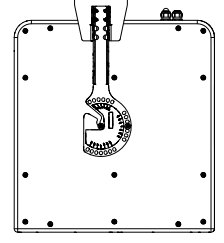
configuration	number of enclosures	reference axis	coverage	resolution	holes used on enclosure
	1	0° (site)	-30° / +30°	10°	A+B
	1	0° (site)	-5° / +5°	10°	A+B (center screw)
	1	-90° (site)	-20° / +20°	10°	A+B

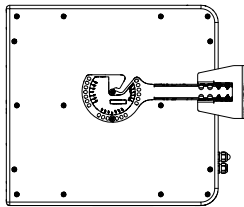
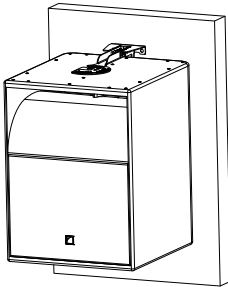
configuration	number of enclosures	reference axis	coverage	resolution	holes used on enclosure
	1	0° (site)	0° / +20° (wall)* -20° / +20° (pillar)	10°	A+B
	2	0° (site)	Refer to coverage table (p.155)	10°	A+B
	1	0° (azimuth)	0° / +20° (wall)* -20° / +20° (pillar)	10°	(-30° to +30°) A+B

i * The cables and connectors at the back of KS21i limit the range of possible site or azimuth angles when the assembly is wall-mounted.

Coverage for a 2-enclosure array mounted with A-U15i

Configuration (top/bottom)	Resolution	Coverage (wall)	Coverage (pillar)
A15i Focus / A15i Focus	10°	0° / +30°	-20° / +30°
A15i Focus / A15i Wide	10°	-10° / +30°	-20° / +30°
A15i Wide / A15i Focus	10°	10°** / +30°	-10° / +30°
A15i Wide / A15i Wide	10°	0° / +30°	-10° / +30°
KS21i / A15i Focus	10°	0° / +20°	-20° / +20°
KS21i / A15i Wide	10°	0° / +20°	-20° / +20°
KS21i / KS21i	10°	0°	-20° / +20°

i ** For a site angle of 0° on a wall, mount A-U15i on a wedge.

Recommendation for speaker cables

Follow the recommended maximum length for loudspeaker cables to ensure minimal SPL attenuation.



Cable quality and resistance

Only use high-quality fully insulated speaker cables made of stranded copper wire.

Use cables with a gauge offering low resistance per unit length and keep the cables as short as possible.

The table below provides the recommended maximum length for loudspeaker cables depending on the cable gauge and on the impedance load connected to the amplifier.

cable gauge			recommended maximum length					
			8 Ω load		4 Ω load		2.7 Ω load	
mm ²	SWG	AWG	m	ft	m	ft	m	ft
2.5	15	13	30	100	15	50	10	33
4	13	11	50	160	25	80	17	53
6	11	9	74	240	37	120	25	80

Use the more detailed L-Acoustics calculation tool to evaluate cable length and gauge based on the type and number of enclosures connected. The calculation tool is available on our website:

<https://www.l-acoustics.com/en/installation/tools/>

Specifications for custom rigging systems

Dimensions

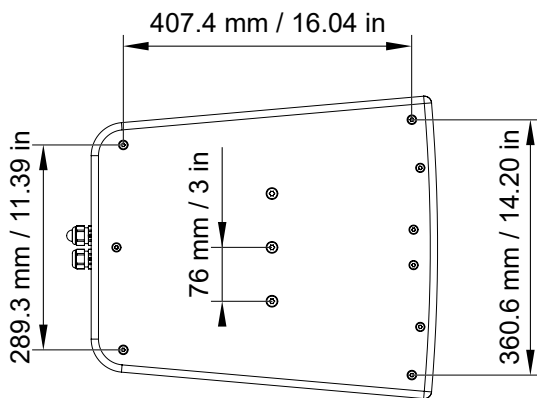
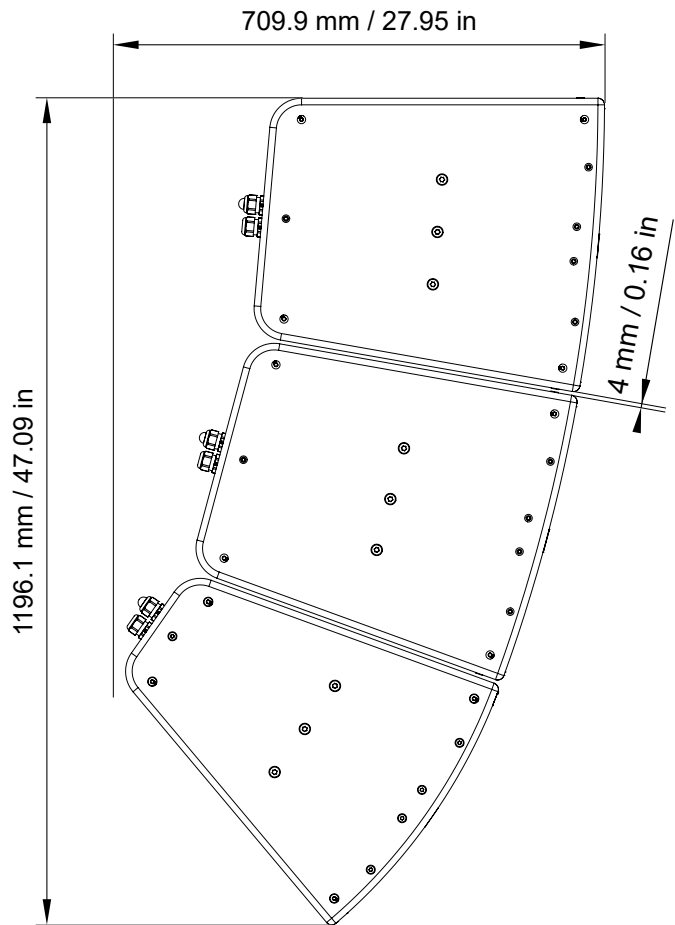
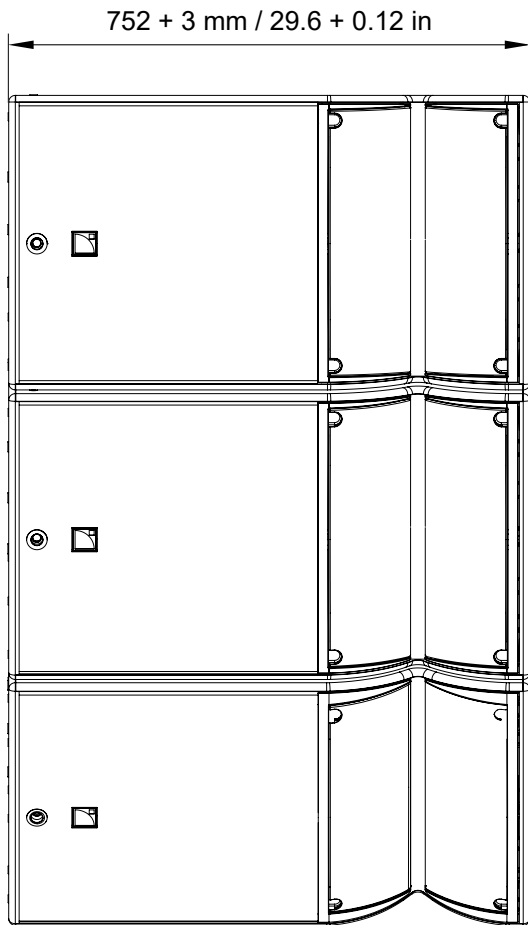

A15i Focus

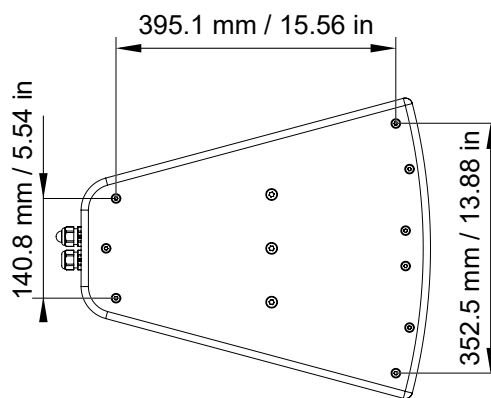

A15i Wide

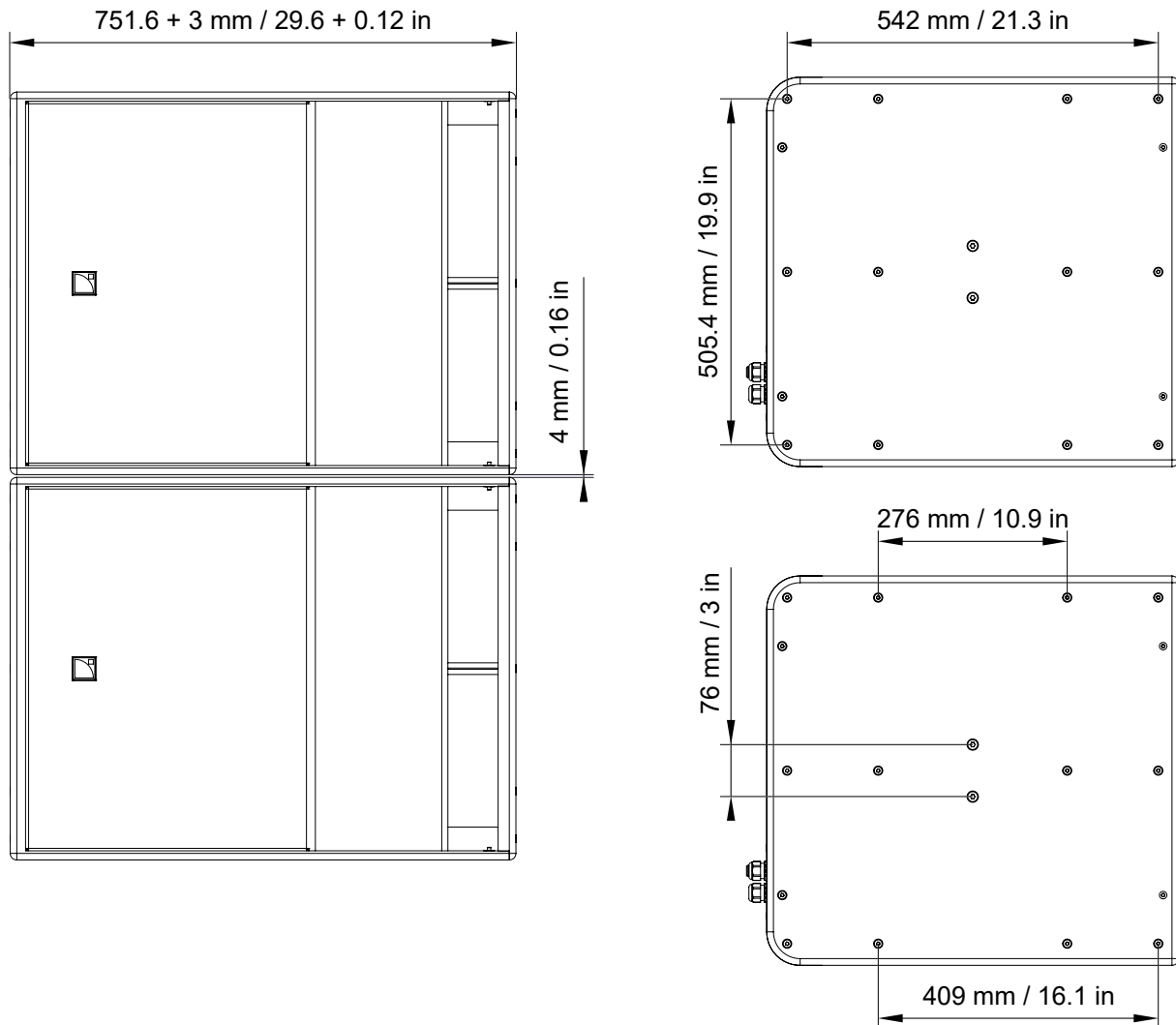

KS21i

Screws

- The grade and threaded length of screws used on the enclosures depend on the design of the metal sheets on the array.
- Recommended screws for a 3 mm thickness metal sheet: M6x18.



Risk of damaging the fins if the length is not respected

Adapt the length of the screws according to the thickness of the sheet.

- Prevent screws from loosening (threadlocker, spring washer...).

Threaded inserts

- Ultimate Tensile Strength: 1160 N
- Ultimate Shear Strength: 5370 N
- Recommended torque: 5 N.m for M6 inserts, 7 N.m for M8 inserts



L-Acoustics

13 rue Levacher Cintrat - 91460 Marcoussis - France
+33 1 69 63 69 63 - info@l-acoustics.com
www.l-acoustics.com



 **L·ACOUSTICS**
GROUP