

PRODUCT DATA

PULSE™ Vibration Check System for Aircraft Engines — Type 3641 including PULSE Standard Configuration 3560-B-T57

To ensure the maintenance of helicopter engines and to optimise the up-time of the aircraft, Brüel & Kjær has developed a system for the field verification on the ground of specific engines based on PULSE Type 3560-B hardware and dedicated software. Vibration measurements are made according to the procedures specified by the engine manufacturer, Turbomeca, in their Maintenance Manual.



USES AND FEATURES

USES

- Vibration checks can be performed on specific aircraft engines according to Turbomeca's specifications

FEATURES

- Verifies the vibration levels with reference to two tachometer signals, one from the gas generator and one from the power turbine (also known as the free turbine) of the engine
- Simplified user interface
- Alarm if level limitations are exceeded
- Alarm if low level occurs (<1 mm/s)
- Automatic storage of results in database
- Contour plot (frequency, speed, level) to aid fault diagnosis
- System can be extended to allow advanced analysis of vibration signals and/or measure static droop
- Mains, aircraft and battery operation
- Automatic recognition of accelerometer and sensitivity by means of TEDS

BENEFITS

- Immediate report produced according to Turbomeca template
- Only one run-up for all measurements to be measured



Description

Fig. 1

Type 3641 is a portable system consisting of a basic system and an engine-specific system



Vibration Check System for Aircraft Engines Type 3641-A consists of a PULSE bundle, Type 3560-B-T57 with hardware and software, a portable PC, a two-channel galvanic isolator for the tachometer signals, an accelerometer with a high-temperature cable with integrated charge converter/filter and TEDS and a water- and shockproof case.

To use Type 3641-A to measure on a specific engine, the user must also select the relevant Brüel & Kjær Type for a specific engine type and engine variant from Table 1.

Table 1

Brüel & Kjær Types for different engine types and variants

Helicopter	Engine Type	Engine Variant	Accelerometers Required	Brüel & Kjær
Super-puma, Rooivalk	MAKILA	1A, 1A1, 1A2, 1K2	1	UA-1678-A-001
Sikorski S76 A/C	ARRIEL	1S, 1S1	2	UA-1678-A-002
Dauphin AS365 C3, N, N1, F	ARRIEL	1C, 1C1, 1M, 1MN	2	UA-1678-A-003
Dauphin AS365 N3, 565UB	ARRIEL	2C	1	UA-1678-A-004
Ecureuil AS350 B/BA-B1/L1, B2/L2	ARRIEL	1B, 1D, 1D1	2	UA-1678-A-005
Ecureuil AS350 B3/EC 130	ARRIEL	2B, 2B1	1	UA-1678-A-006
Sikorski S76 C+	ARRIEL	2S1	1	UA-1678-A-007
Dauphin AS365 C, C1, C2	ARRIEL	1A, 1A1, 1A2	2	UA-1678-A-008
EC 155	ARRIEL	2C1, 2C2	1	UA-1678-A-009
BK 117, EC 145	ARRIEL	1E1, 1E2	2	UA-1678-A-010
Agusta 109K2	ARRIEL	1K1	2	UA-1678-A-011
AS 365N2, 365K, 365MA	ARRIEL	1C2, 1M1, 1MN1	2	UA-1678-A-012
EC 225/EC 725	MAKILA	2A	2	UA-1678-A-013
AS 355, 55N	ARRIUS	1A, 1M	1	UA-1678-A-014
EC T1, T2	ARRIUS	2B1, 2B1A, 2B2	1	UA-1678-A-015
A109 power, LUH	ARRIUS	2K1, 2K2	1	UA-1678-A-016
ALH	TM333	2B, 2B2, 2M2	1	UA-1678-A-017
NH90	RTM322	01-9	1	UA-1678-A-018
EH 101	RTM322	01-8	1	UA-1678-A-019
EC 120	ARRIUS	2F	1	UA-1678-A-020
Apache	RTM322	01-12	1	UA-1678-A-021
SA 330 Puma	TURMO IV	C	1	UA-1678-A-022
All other helicopters				Please contact Brüel & Kjær
Note: Where 2 accelerometers are required, then Types 3648-A and 3649-A must be supplemented with an extra Accelerometer Type 8324-G				

Note that Type 3641-B is the same as Type 3641-A, but does not contain Charge Accelerometer Type 8324-G.

The system is installed in a weather- and shockproof carrying case. Engine-specific cables are stored in a robust shoulder-bag clearly labelled with the relevant engine type (Fig. 2).

Fig. 2 Carrying case and shoulder bag



Fig. 3 Charge Accelerometer Type 8324-G with calibration chart and accessories



Fig. 4
Cabling for
(a) single- and (b) dual-
accelerometer systems

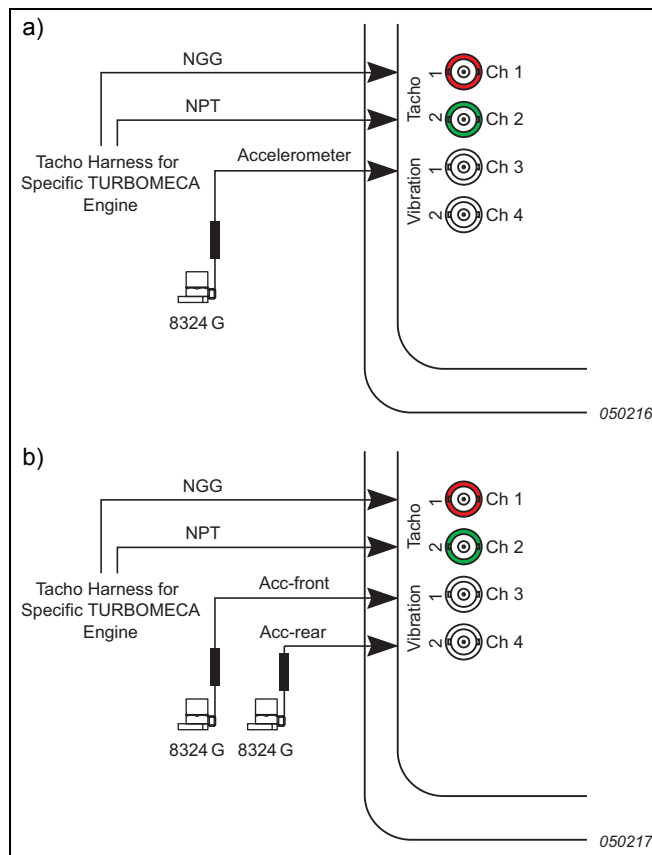

The necessary Charge Accelerometer Type 8324 is included in the high-temperature cable, charge converter and TEDS unit (Fig. 3). Users who already possess a Charge Accelerometer Type 8324 can send the accelerometer to Brüel & Kjær for calibration with the required cable, or purchase a TEDS Editor Kit and read the data into the TEDS unit themselves. Systems for other helicopter engines are under preparation.

The simple user interface leads the technician from the identification of the engine, via the monitoring of the signals and comparison with threshold levels (the verification). The signal is stored in a database and service report is produced where the results are clearly indicated as “Passed” or “Limit Exceeded” (Fig. 6).

The report can be sent directly to the engine manufacturer. With the PULSE Data Manager Type 7767 option, a copy of the time signal can accompany the report. Further analysis can be performed by using PULSE products. Type 7906-S1 Vibration Analysis for Aircraft Engines (requires Type 7795-N) is a suite of three products that enables up to four channels of FFT and order analysis and access to PULSE Data Manager.

Fig. 5
Result of a 70second run-up on a helicopter engine

Upper left: Level of 1st order vibration using a tachometer from the generator

Lower left: Level of first order vibration using a tachometer from the turbine

Upper right: Tachometer profiles.
Lower right: Control and status window

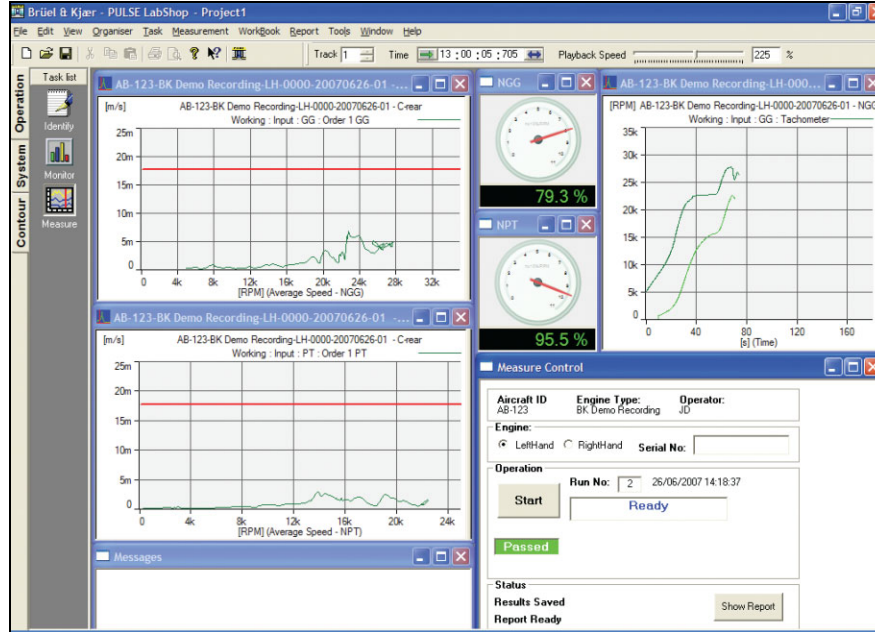

Fig. 6 Automatically generated report in Microsoft® Word

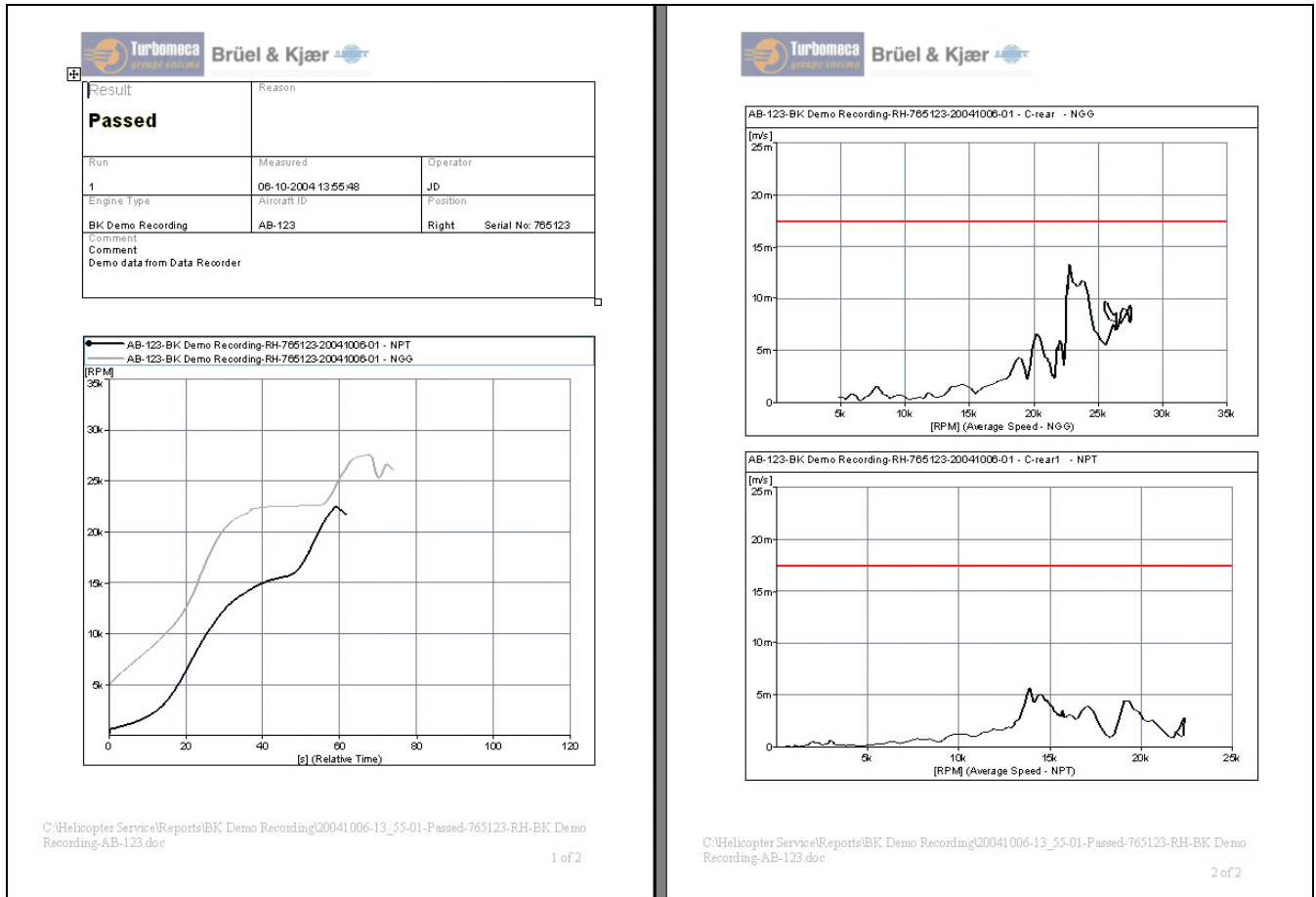

Fig. 7 Identification screen: system setup (left), instructions (right)

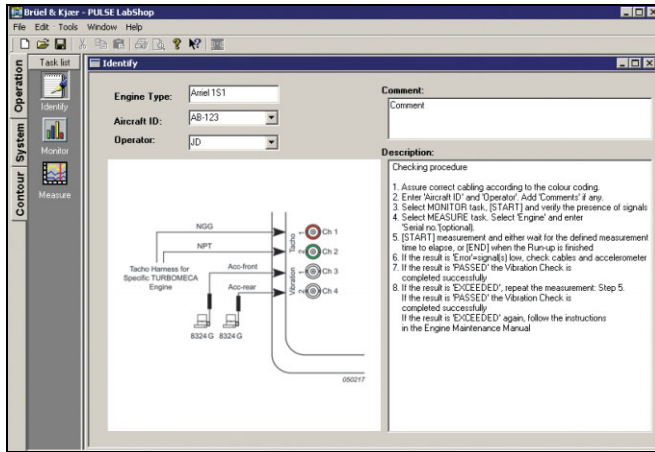
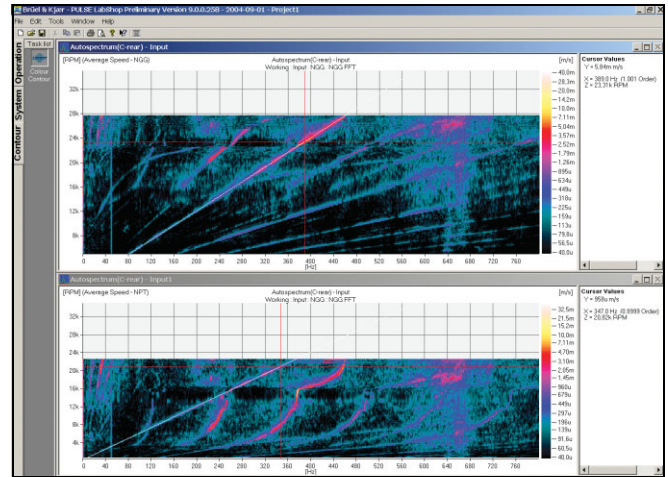

Fig. 8 Order plots for 1st order vibration signals using a tachometer from the generator (upper plot) and a tachometer from the turbine (lower plot)



Static Droop

On engines with mechanical speed governors, it can be necessary to check or adjust the governor for Static Droop (SD) after replacing an engine's Fuel Control Unit (FCU) or at specified operating intervals.

Static Droop for MAKILA 1A2 Type 8604-A-001 is an 'add-on' application to the Vibration Check System to provide a means for measuring Static Droop (SD) on the MAKILA 1A2 engine (other engine types and variants can be covered on request).

The SD measurement is performed by recording Gas Generator rpm¹⁾ (NGG) and the Rotor rpm (NR) derived from the Power Turbine rpm (NPT) at a number of different NGG – typically a minimum of five points between flight-idle and 90%. At the pre-specified NGG, the operator records the NR by clicking the **Add Value** button. The software calculates and displays a curve, an example of which is shown in Fig. 9, where the actual NR is compared with a theoretical tolerance band.

The FCU Slope & Zero screw adjustments required to bring the curve back into tolerance are automatically calculated, and displayed together with an indication of when adjustment limits are exceeded.

Fig. 9 Actual NR plus the theoretical max/min NR limits for a reference NGG



1)The MAKILA 1A2 Static Droop application uses the same tachometer harness as with the Vibration Check System.

Explanation of Errors and Messages for Aircraft Engine Tests

A collection of different circumstances can cause Messages and Errors to be reported in the Aircraft Engine Test software.

Messages

Messages tell you if the measurement has passed or if the vibration signal exceeded the allowable limits. The possible messages are listed in Table 2.

Table 2
Messages

Signal	Limit Type	Messages
Vib1		PASSED
	1 st Order Limit	Vib1, NGG Exceeded
		Vib1, NPT Exceeded
	[Overall Limit]	Vib1, OA Exceeded
[Vib2]		PASSED
	1 st Order Limit	Vib2, NGG Exceeded
		Vib2, NPT Exceeded
	[Overall Limit]	Vib2, OA Exceeded

Vib1 and Vib2 are the specific signal names as given by the manufacturer!
[in brackets: optional!] – only required for certain engines

Errors

Errors tell you that the signal is too low on a channel. This is most likely due to a broken cable, transducer, or hardware. The possible errors are listed in Table 3.

Table 3
Errors

Situation	Error
Signal too low on 1 st order of Vibration signal with NGG tacho reference and Signal OK on 1 st order of Vibration signal with NPT tacho reference	ERROR on NGG
Signal too low on 1 st order of Vibration signal with NPT tacho reference and Signal OK on 1 st order of Vibration signal with NGG tacho reference	ERROR on NPT
Signal too low on 1 st order of Vibration signal with NGG tacho reference and Signal too low on 1 st order of Vibration signal with NPT tacho reference	ERROR on Vib1 or NGG or NPT (Check Signal Monitors to validate source of error)

The errors are calculated using:



$$\frac{\sum_{n=0}^{\text{total}-1} P_n}{\text{total}} \cdot 0.70 < \text{Limit}$$

where P_n is the power spectrum of the 1st Order and “total” is the total number of points in the acquired slice. The formula says that 70% of the slice must be over a predefined “limit”; otherwise an error is given.

There is also a priority that dispatching Errors and Messages must follow:

- If there is an ERROR no Messages may be given
- There may be multiple messages, but only one ERROR at a time
- If PASSED is given, there may be no other messages or ERRORS at the same time

Compliance with Standards – Type 3641

 	CE-mark indicates compliance with: EMC Directive and Low Voltage Directive. C-Tick mark indicates compliance with the EMC requirements of Australia and New Zealand.
Safety	EN/IEC61010-1: Safety requirements for electrical equipment for measurement, control and laboratory use. UL 61010B-1: Standard for Safety – Electrical measuring and test equipment.
EMC Emission	EN/IEC61000-6-3: Generic emission standard for residential, commercial and light industrial environments. EN/IEC61000-6-4: Generic emission standard for industrial environments. CISPR 22: Radio disturbance characteristics of information technology equipment. Class B Limits. FCC Rules, Part 15: Complies with the limits for a Class B digital device.
EMC Immunity	EN/IEC61000-6-1: Generic standards – Immunity for residential, commercial and light industrial environments. EN/IEC61000-6-2: Generic standards – Immunity for industrial environments. EN/IEC61326: Electrical equipment for measurement, control and laboratory use – EMC requirements. Note: The above is only guaranteed using accessories listed in this Product Data.
Temperature	IEC 60068-2-1 & IEC 60068-2-2: Environmental Testing. Cold and Dry Heat. Operating Temperature: -10 to +50°C (14 to 122°F) Storage Temperature: -25 to +70°C (-13 to 158°F)
Humidity	IEC 60068-2-78: Damp Heat: 93% RH (non-condensing at 40°C (104°F))
Mechanical	Non-operating: IEC 60068-2-6: Vibration: 0.3mm, 20 ms ⁻² , 10 – 500 Hz IEC 60068-2-27: Shock: 500 ms ⁻² IEC 60068-2-29: Bump: 3000 bumps at: 250 ms ⁻²
Enclosure	IEC 60529: Protection provided by enclosures: IP 67

For environmental specifications and compliance with standards for PCs, see the specifications given by their respective manufacturers.

For PULSE Front-end Type 3560-B, see System Data BU 0228
For Accelerometer Type 8324-G, see Product Data BP 2143

Specifications – PULSE Vibration Check System for Aircraft Engines Type 3641

Basic System Type 3641-A

WEIGHT

KE-1014 Water- and Shockproof Case:
12 kg (26.5 lb.), without cables

DIMENSIONS

190 × 360 × 450 mm (7.7 × 14.2 × 17.7")

KE-1013 Shoulder-bag for Cables

Weight: 3 kg (6.6 lb.)

PC Included

DELL™ Latitude® D600 or equivalent

Ordering Information

Basic System Type 3641-A

- Type 3560-B-T57: PULSE vibration check system for aircraft engines, and the necessary software, including:
 - Type 3560-B-020: PULSE B Frame, 2 × QB-0048 Batteries
 - Type 7795-N: PULSE Vibration Check for Aircraft Engines, Node-locked License
 - M1-7795-N: Annual Software Maintenance and Support Agreement for Type 7795-N

- Delivered in a water- and shockproof case containing Type 3560-B-020 Frame, portable PC, two-channel galvanic Isolator for two tachometer signals, powering electronics, etc.
- Type 8324-G: Accelerometer with High-temperature cable, integrated charge converter/filter and TEDS (10 m in all)

Basic System Type 3641-B

As Type 3641-A, but without Type 8324-G

Engine-specific Systems

Each engine-specific system listed below includes a PULSE Vibration Check Configuration, an Annual Software Maintenance and Support Agreement, a Tacho Harness and a Shoulder-bag for Cables:

Engine-specific System	For Testing TURBOMECA Engines	PULSE Vibration Check Configuration (Node-locked License)	Annual Software Maintenance and Support Agreement	Tacho Harness (10 m)	Shoulder-bag for Cables KE-1013
UA-1678-A-001	MAKILA 1A, 1A1, 1A2, 1K2	Type 7795-A-001	M1-7795-A-001	AO-1479-A-001	Included
UA-1678-A-002	ARRIEL 1S, 1S1	Type 7795-A-002	M1-7795-A-002	AO-1479-A-002	Included
UA-1678-A-003	ARRIEL 1C, 1C1, 1M, 1MN	Type 7795-A-003	M1-7795-A-003	AO-1479-A-003	Included
UA-1678-A-004	ARRIEL 2C	Type 7795-A-004	M1-7795-A-004	AO-1479-A-004	Included
UA-1678-A-005	ARRIEL 1B, 1D, 1D1	Type 7795-A-005	M1-7795-A-005	AO-1479-A-005	Included
UA-1678-A-006	ARRIEL 2B, 2B1	Type 7795-A-006	M1-7795-A-006	AO-1479-A-006	Included
UA-1678-A-007	ARRIEL 2S1	Type 7795-A-007	M1-7795-A-007	AO-1479-A-007	Included
UA-1678-A-008	ARRIEL 1A, 1A1, 1A2	Type 7795-A-008	M1-7795-A-008	AO-1479-A-008	Included
UA-1678-A-009	ARRIEL 2C1, 2C2	Type 7795-A-009	M1-7795-A-009	AO-1479-A-009	Included
UA-1678-A-010	ARRIEL 1E1, 1E2	Type 7795-A-010	M1-7795-A-010	AO-1479-A-010	Included
UA-1678-A-011	ARRIEL 1K1	Type 7795-A-011	M1-7795-A-011	AO-1479-A-011	Included
UA-1678-A-012	ARRIEL 1C2, 1M1, 1MN1	Type 7795-A-012	M1-7795-A-012	AO-1479-A-012	Included
UA-1678-A-013	MAKILA 2A	Type 7795-A-013	M1-7795-A-013	AO-1479-A-013	Included
UA-1678-A-014	ARRIUS 1A, 1M	Type 7795-A-014	M1-7795-A-014	AO-1479-A-014	Included
UA-1678-A-015	ARRIUS 2B1, 2B1A, 2B2	Type 7795-A-015	M1-7795-A-015	AO-1479-A-015	Included
UA-1678-A-016	ARRIUS 2K1, 2K2	Type 7795-A-016	M1-7795-A-016	AO-1479-A-016	Included
UA-1678-A-017	TM333 2B, 2B2, 2M2	Type 7795-A-017	M1-7795-A-017	AO-1479-A-017	Included
UA-1678-A-018	RTM322 01-9	Type 7795-A-018	M1-7795-A-018	AO-1479-A-018	Included
UA-1678-A-019	RTM322 01-8	Type 7795-A-019	M1-7795-A-019	AO-1479-A-019	Included
UA-1678-A-020	ARRIUS 2F	Type 7795-A-020	M1-7795-A-020	AO-1479-A-020	Included
UA-1678-A-021	RTM322 01-12	Type 7795-A-021	M1-7795-A-021	AO-1479-A-021	Included
UA-1678-A-022	TURMO IV C	Type 7795-A-022	M1-7795-A-022	AO-1479-A-022	Included

For systems for other engine types, please contact Brüel & Kjær

Accessories Required for Editing TEDS

- BZ-5294: TEDS Editor software
- BZ-5294-MS5: TEDS Editor Developer's License
- WQ-1320: MicroLAN Adaptor DS 9097U-009
- WL-1363: BNC to MMP-4R Cable for DS 9097

Optional Accessories

- Type 4294-002: Calibration Exciter, max. load 200 gram
- Type 8324-G: Accelerometer with High-temperature cable, integrated charge converter/filter and TEDS (10m in all)
- Type 8324: Charge Accelerometer
- 8324-G-CAI: Accredited Initial Calibration of Type 8324
- 8324-G-CAF: Accredited Calibration of Type 8324
- 8324-G-EW1: Extended Warranty for Type 8324, 1 year extension

- Type 2647-D-001: Charge Converter/Filter integrated in a high-temperature cable
- Type 7767-A-N: PULSE Data Manager
- Type 7906-S1: PULSE Vibration Analysis for Aircraft Engines comprising:
 - Type 7770-N5: FFT analysis
 - M1-7770-N5: Annual Software Maintenance and Support Agreement for Type 7770
 - Type 7702-N1: Order Tracking
 - M1-7702-N1: Annual Software Maintenance and Support Agreement for Type 7702
 - Type 7767-A-N: PULSE Data Manager
 - M1-7767-A-N: Annual Software Maintenance and Support Agreement for Type 7767
- Type 8604-A-001: Static Droop (for Turbomeca MAKILA 1A2)
- 3560-B-EW1: Extended Warranty for Type 3560-B

TRADEMARKS

MAKILA and ARRIEL are registered trademarks of Turbomeca Corporation, France
Dell is a trademark and Latitude is a registered trademark of Dell Computer Corporation
Microsoft is a registered trademark of Microsoft Corporation

Brüel & Kjær reserves the right to change specifications and accessories without notice

HEADQUARTERS: DK-2850 Nærum · Denmark · Telephone: +45 4580 0500
Fax: +45 4580 1405 · www.bksv.com · info@bksv.com

Australia (+61) 2 9889-8888 · Austria (+43) 1 865 74 00 · Brazil (+55) 11 5188-8161
Canada (+1) 514 695-8225 · China (+86) 10 680 29906 · Czech Republic (+420) 2 6702 1100
Finland (+358) 9-755 950 · France (+33) 1 69 90 71 00 · Germany (+49) 421 17 87 0
Hong Kong (+852) 2548 7486 · Hungary (+36) 1 215 83 05 · Ireland (+353) 1 807 4083
Italy (+39) 0257 68061 · Japan (+81) 3 5715 1612 · Republic of Korea (+82) 2 3473 0605
Netherlands (+31) 318 55 9290 · Norway (+47) 66 77 11 55 · Poland (+48) 22 816 75 56
Portugal (+351) 21 4169 040 · Singapore (+65) 6377 4512 · Slovak Republic (+421) 25 443 0701
Spain (+34) 91 659 0820 · Sweden (+46) 33 225 622 · Switzerland (+41) 44 8807 035
Taiwan (+886) 2 2502 7255 · United Kingdom (+44) 14 38 739 000 · USA (+1) 800 332 2040

Local representatives and service organisations worldwide

Brüel & Kjær 

