

CREATIVE®

SoundBLASTER®
FREE



User's Guide

Model No: SB1660

Introduction

Thank you for choosing the Creative Sound Blaster FRee (SB1660) *Bluetooth*[®] speaker. With its high performance speaker drivers, the splash-proof portable speaker delivers powerful 360° sound and enhanced bass for your audio playback.

Play your favourite tunes wirelessly through *Bluetooth* or directly from a microSD card with the integrated music player. It even supports digital USB audio streaming from a PC or Mac with added SBX Pro Studio™ enhancements. It can be used as a *Bluetooth* speakerphone too!

Package Checklist

Your Sound Blaster FRee package comes with the following:

- Sound Blaster FRee *Bluetooth* speaker
- 0.4m Micro-USB cable
- Quick Start leaflet
- Warranty leaflet
- Safety & Regulatory leaflet

System Requirements

For Windows[®] OS

- Intel[®] Core™2 Duo or AMD equivalent processor, 2.8 GHz or faster recommended
- Microsoft[®] Windows 8.1 64-bit or 32-bit, Windows 8 64-bit or 32-bit, Windows 7 64-bit or 32-bit
- 1 GB RAM
- 600 MB of free hard disk space
- Powered USB 2.0 / USB 3.0 port

For Mac[®] OS

- Intel[®] Core™2 Duo, 2.8 GHz or faster recommended
- Mac OS X[®] 10.7.5 or higher
- 1 GB RAM
- 600 MB of free hard disk space
- Powered USB 2.0 / USB 3.0 port

For iOS device

- iPhone[®] / iPad[®] running iOS 5.1.1 or higher for *Bluetooth*

For Android device

- Phone / tablet running Android 2.3 or higher for *Bluetooth*

Registering Your Product

Registering your product ensures you receive the most appropriate service and product support available. You can register your product during installation or at register.creative.com. Please note that your warranty rights are not dependent on registration.

More Help

For the latest news and products for the Sound Blaster, please visit www.soundblaster.com. The site also includes information on making purchases, technical help and the latest software updates.

Using Creative Software AutoUpdate

Locating, downloading and installing updates for your Creative products is now simpler and faster with the web-based Creative Software AutoUpdate system.

When you connect to Creative Software AutoUpdate via the Internet, the website will analyze your computer system to determine your operating system, language and which Creative products are connected to your system.

When this analysis is completed, you will then be given a list of only the most relevant software updates for your connected products. The files can then be retrieved and installed.

To learn more about the Creative Software AutoUpdate, please visit support.soundblaster.com.

Note:

*First-time users of Creative Software AutoUpdate may be prompted to authorize the download of a browser component required for system analysis. Check to ensure that this content is signed by Creative Labs, Inc., then click the **Yes** button.*

Please ensure that all your Creative products are connected and installed on the same computer running Creative Software AutoUpdate.

Product Overview

The buttons located at the top and rear of Sound Blaster FRee gives you basic control over the system's functions. The rear of the speaker has jacks for USB and 3.5 mm analog audio in, as well as a microSD slot for audio playback.



	Item	Description
1	Bluetooth LED indicator	Indicates the <i>Bluetooth</i> pairing and connection status. Blue (slow blink): <i>Bluetooth</i> standby mode Blue (fast blink): <i>Bluetooth</i> discovery mode Blue: <i>Bluetooth</i> is paired
2	Phone/ <i>Bluetooth</i> button	Press to answer a call or enter <i>Bluetooth</i> discovery mode. Answer/end call: Press once to answer a call. Press again to end it. Bluetooth: Press and hold 2 seconds until a beep is heard. The speaker will then enter <i>Bluetooth</i> discovery mode.
3	Volume + button	Press to increase volume. Press and hold to increase volume to maximum.
4	Power button	Press to power on/off.
5	Battery status indicator	Indicates the device's battery level. ● ● ● Full

	Item	Description
		<ul style="list-style-type: none"> ● ● ○ Med ● ○ ○ Low ☀ ○ ○ Critical Low ☀☀☀☀ (3 blinks): Minimum/maximum volume
6	Volume - button	Press to decrease volume. Press and hold to decrease volume to minimum.
7	Microphone	Built-in microphone for voice pickup.

Music Player

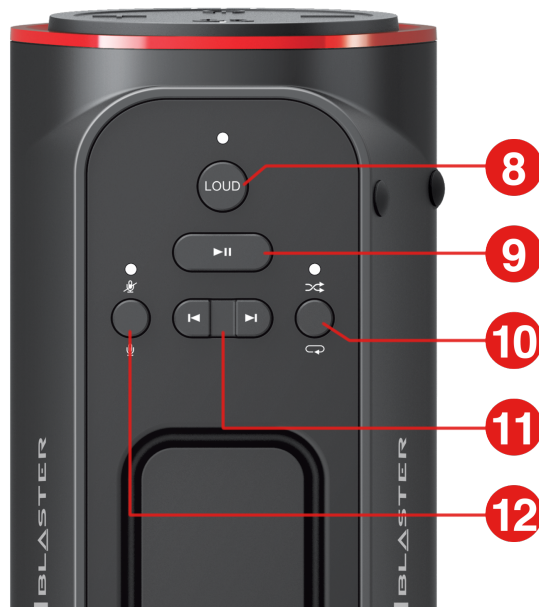

	Item	Description
8	LOUD button	Press to boost volume and spaciousness. LOUD mode will be automatically turned off when the battery is critically low. Caution: More power will be consumed in this mode. Playtime will be reduced.
9	Play/Pause button	Press to play or pause a track.
10	Shuffle/Repeat All button	Press to select random play or repeat all tracks. Green: Shuffle Off: Repeat all

	Item	Description
11	Next/Previous button	Press to skip track. Press and hold to skip folder.
12	Mic Mute button	Press to mute or unmute internal microphone. Red: Mic mute Off: Mic unmute

Input / Output Interface



	Item	Description
13	Micro-USB port	Connects to the USB port of a computer for audio streaming and battery charging.
14	Aux-in jack	Connects to line-level sources (smartphones, tablets, MP3 players) with a 3.50 mm (1/8-inch) plug.
15	MicroSD slot	Supports up to 32GB microSD card for audio playback.
16	Rear passive radiator	For enhanced bass.

Setting Up Your Audio Device

Step 1: Charging Your Sound Blaster FRee

Sound Blaster FRee comes with a built-in rechargeable battery that provides up to 10 hours of playtime when fully charged. Charge the speaker before its first use by connecting it to a USB port on your computer or to a 5V USB power adapter (not included). Each subsequent charge cycle takes around 3 to 4 hours.

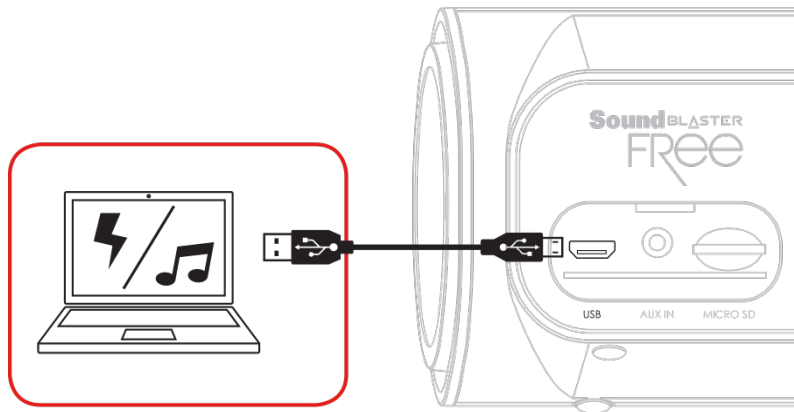

Auto Power Off

To save power, the speaker automatically powers down after 15 minutes of inactivity.

Note:

Lithium-ion battery life may suffer when it is constantly fully depleted or overexerted at low voltage. It is a good practice to keep the battery well charged.

Step 2: Turning On Sound Blaster FRee

Press the **Power** button to turn Sound Blaster FRee on. Press again to power it off.

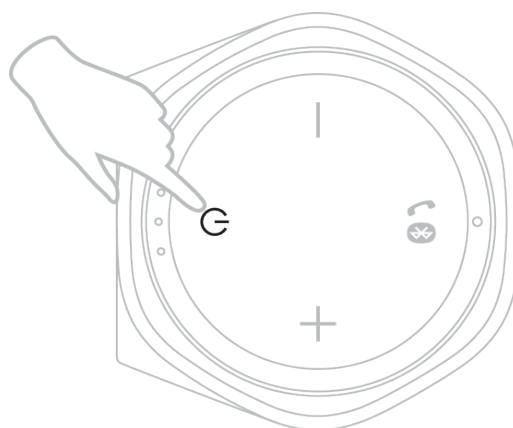

Note:

If the speaker has not been paired with any devices previously, it will go into Bluetooth standby mode. Otherwise, it will be automatically paired to previously paired devices.

Step 3: Connecting to an Audio Source

Bluetooth Pairing

To activate *Bluetooth*, press and hold the **Phone/Bluetooth** button for 2 seconds.

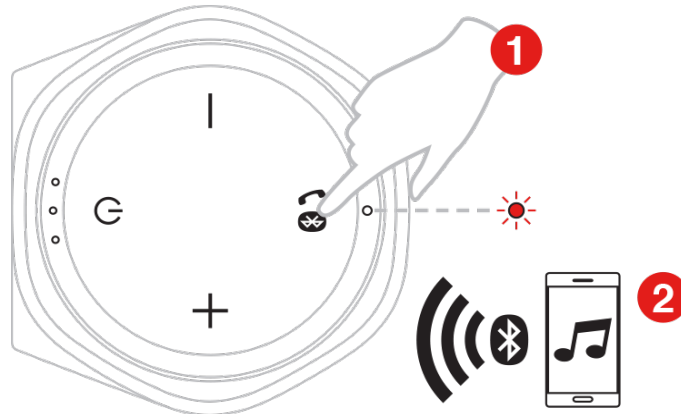

	Action	LED Status	Status
1	Press and hold the Phone/Bluetooth button for 2 seconds.	Blue (fast blink)	<i>Bluetooth</i> discovery mode. Ready to be paired with new device.
2	Turn on <i>Bluetooth</i> on your device. Search and select "Sound Blaster FRee".	Blue	Ready to stream music.

Note:

If no device is paired within 1 minute, it will exit from Bluetooth discovery mode.

Bluetooth pairing between these devices may vary depending upon the model type. Consult your device's manual on how to pair.

The Sound Blaster FRee supports dual connections, which means you can connect it to two Bluetooth devices at the same time. If you wish to connect it with a third device, you should disconnect the existing two devices first before connecting it to the other device.

USB Connection

Connect your Sound Blaster FRee to a computer using the Micro-USB cable provided.

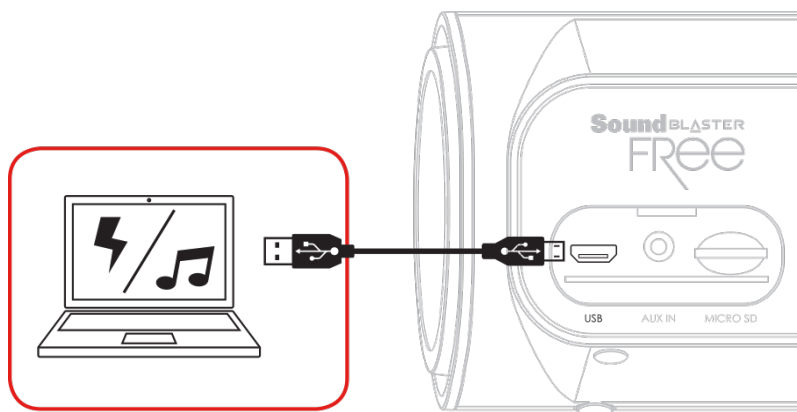

Setting Sound Blaster FRee as the default audio device:

For Windows

- i. Go to **Control Panel** and click **Sound**.
- ii. Click the **Playback** tab, select **Sound Blaster FRee**, then click the **Set Default** button.

For Mac

- i. Go to **System Preferences** and click **Sound**.
- ii. Click the **Output** tab, then select **Sound Blaster FRee**.

Analog Connection

The Sound Blaster FRee also lets you connect devices using the 3.5mm mini stereo cable (not included).

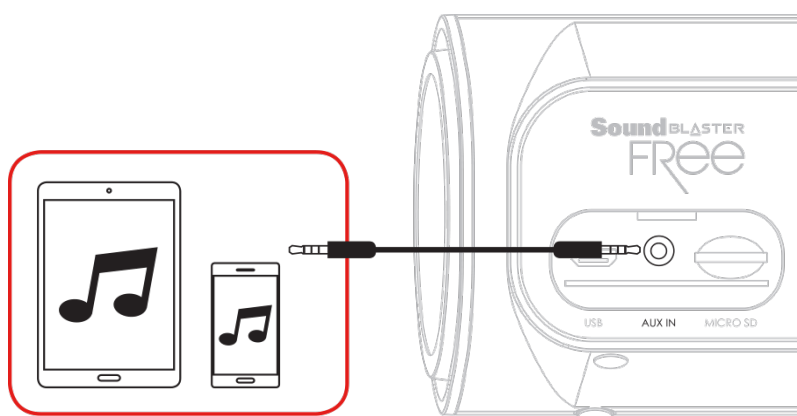

MicroSD card via integrated MP3 player

The Sound Blaster FRee can play audio files from a microSD card with the built-in MP3 player.

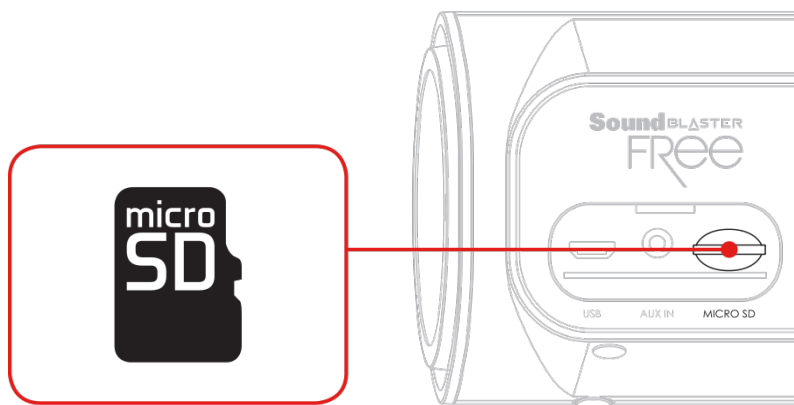

It supports microSD, microSDHC and microSDXC cards (not included) of up to 32GB in FAT16 or FAT32 format. You can play MP3, WAV or FLAC format files.

MP3	8 kHz - 48 kHz 8 kbps - 320 kbps
WAV (PCM)	8 kHz - 48 kHz, 16 bits
FLAC	8 kHz - 48 kHz, 16 bits

Using Your Audio Device

Your Sound Blaster FRee works seamlessly with many external devices to perform different tasks.

Playing music

Connect your favourite music sources to the speaker in four simple ways.

- USB connection
- Analog connection
- MicroSD card
- *Bluetooth* connection

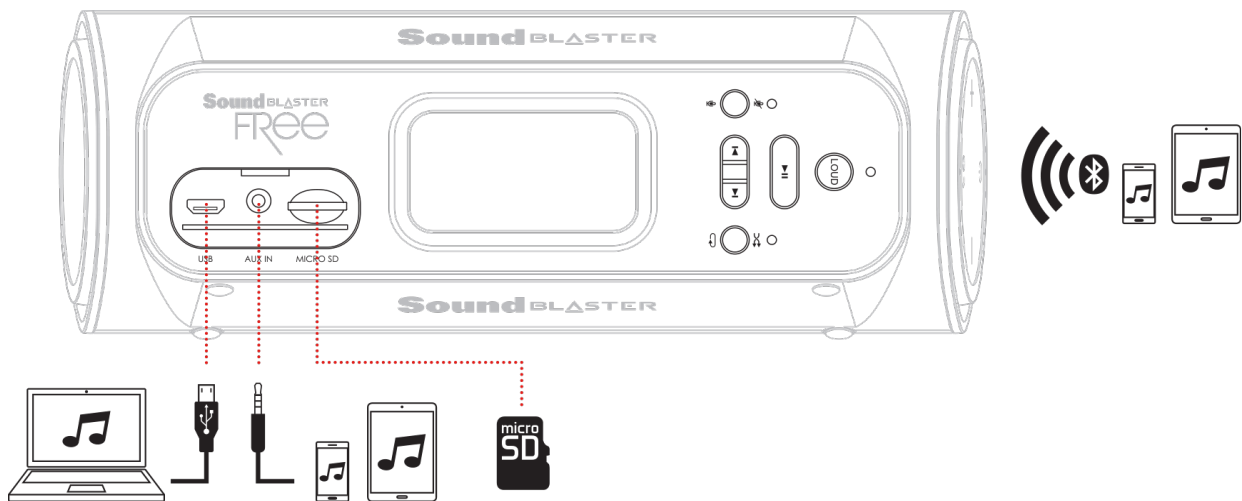

Play/pause music: Press **Play/Pause** button

Boost volume and spaciousness: Press **LOUD** button

Skip tracks/folders

- Skip tracks: Press **Next/Previous** button
- Skip folders: Press and hold **Next/Previous** button

Shuffle/repeat all: Press **Shuffle/Repeat All** button*

Adjust speaker volume:

- Increase volume: Press **Volume +** button
- Decrease volume: Press **Volume -** button

Note:

**The Shuffle/Repeat All function is only available for microSD card playback.*

*When a microSD card is inserted while Bluetooth is connected, the **Play/Pause** and **Next/Previous** buttons control the music playback from the microSD card.*

Answering calls

When there's an incoming call, the call takes precedence over audio playback – playback stops and the ringtone will be heard.

Press the **Phone/Bluetooth** button once to answer the call. Press again to end the call.

The music will resume after the call has ended.

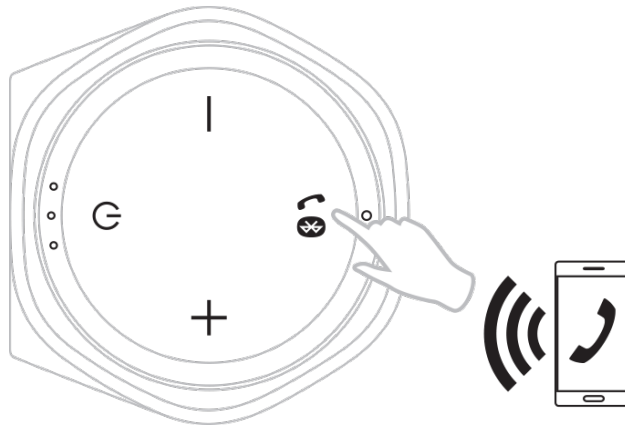

Answer/end call: Press **Phone/Bluetooth** button

Mute/unmute mic: Press **Mic Mute** button

Adjust speaker volume:

- Increase volume: Press **Volume +** button
- Decrease volume: Press **Volume -** button

Installing and Uninstalling Software

To take full advantage of your Sound Blaster FRee audio device, you need to install device drivers and applications. At times, you may also need to uninstall some or all of the device drivers and applications to correct problems, change configurations, or upgrade outdated drivers or applications. To learn how to do so in all supported Windows and Mac operating systems, consult the following sections:

- Installing Drivers and Applications
- Uninstalling Drivers and Applications

Installing Drivers and Applications

Ensure that your audio device is connected before proceeding. For instructions on connecting your audio device, consult your Quick Start leaflet.

After you have connected your audio device, turn on your computer. Windows automatically detects your audio device and searches for device drivers.

For Windows OS

1. Using a standard web browser, visit support.creative.com.
2. Locate **Sound Blaster FRee** and the software package for your Windows operating system.
3. Download this package into your local hard disk.
4. Locate and launch the software package.
5. Follow the on-screen instructions to complete the installation.
6. When prompted, restart your computer.
7. Launch the application by locating and clicking **Sound Blaster FRee Control Panel**.

For Mac OS

1. Using a standard web browser, visit support.creative.com.
2. Locate **Sound Blaster FRee** and the software package for your Mac OS.
3. Download this package into your local hard disk.
4. Double-click the downloaded file to uncompress it.
5. Double-click the uncompressed DMG file.
6. Double-click the **Install** icon and follow the subsequent on-screen instructions to complete the installation.
7. Launch the **Sound Blaster FRee Control Panel** from the **Applications > Creative** folder.

Note:

Depending on your operating system, model and software version, the user interface or color theme may differ.

Uninstalling Drivers and Applications

In the event that an uninstallation is required (such as for upgrades), please follow the following procedure.

Before you begin, close all running audio applications. Applications that are still running during uninstallation will not be removed.

For Windows OS

1. From the **Control Panel**, click **Uninstall a program**.
2. Select your audio device's entry.
3. Click the **Uninstall** button or option.
If the **User Account Control** dialog box appears, click the **Continue** button.
4. Click the **Yes** button.
5. When prompted, restart your computer.

For Mac OS

1. Click **Applications > Creative > Creative Uninstaller**.
2. Select the Creative product to be uninstalled.
3. Click the **Uninstall** button.
4. Follow the on-screen instructions.

Using the Creative Software Suite

A specialized software for the Sound Blaster FRee is developed to provide additional enhancements to the audio and voice inputs and outputs of the product. The software bundle supports a range of operating systems including:

- Windows 8.1, Windows 8, Windows 7
- Mac

To take full advantage of your Sound Blaster FRee, we recommend downloading and installing this software into your computer. The following applications are included in the software bundle:

For Windows OS,

- Sound Blaster FRee Control Panel
- Creative Software AutoUpdate
- Creative System Information
- Product Registration
- Creative ALchemy
- Host OpenAL
- Creative Driver

For Mac OS,

- Sound Blaster FRee Control Panel
- Product Registration
- Creative Uninstaller

Note:

Some applications are available only for certain operating systems. To learn more about each application, please consult its respective Online Help.

Sound Blaster FRee Control Panel

The rest of this chapter explains how to use the Sound Blaster FRee Control Panel to view and adjust the various features of your Sound Blaster FRee. The examples and screenshots below uses Windows as an example. The UI for other operating systems may differ slightly.

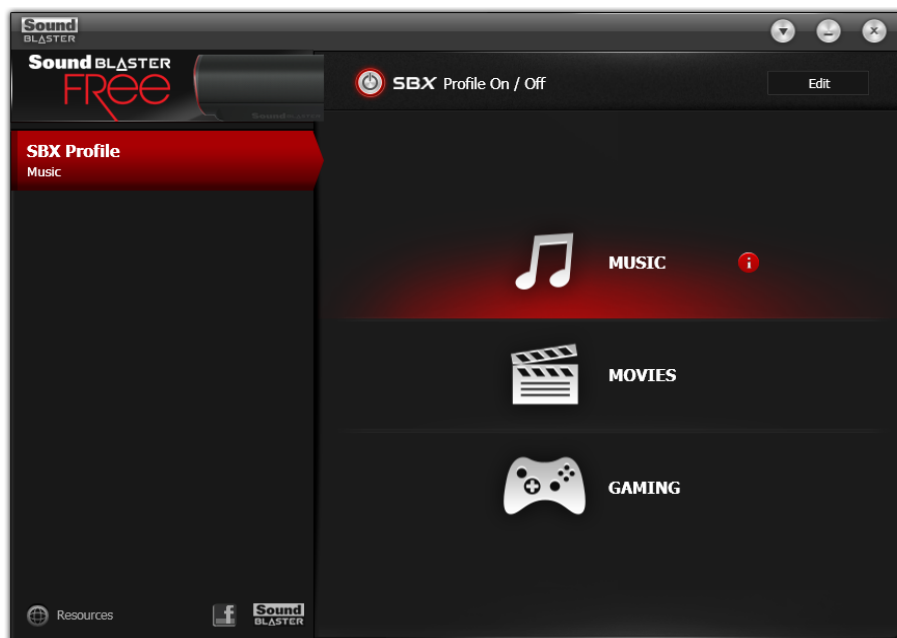

Configuring Your General Settings

You can change the language settings or restore settings to their default values. Click  from the top right corner of the interface and select the option from the list.

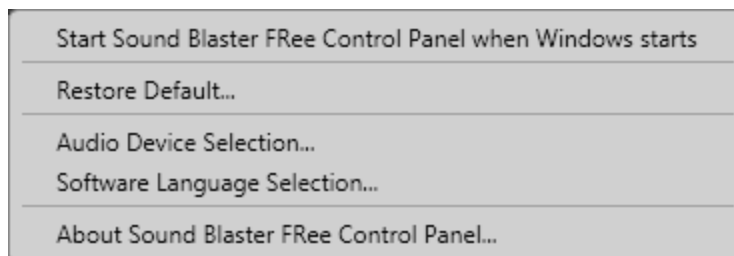

Managing Your Profiles

The Sound Blaster FRee Control Panel comes equipped with a set of pre-configured profiles to suit your different needs including:



- Music
- Movies
- Gaming

To activate a profile, select your desired profile from the screen. Click the **Edit** button to modify the profile you have selected.

SBX Pro Studio Settings

To configure SBX Pro Studio, select a profile and click **Edit** to enter the **SBX Pro Studio** screen. By default, the SBX effect is turned on. You may adjust the effects on this screen.



1. Click the  button to toggle ON SBX Pro Studio.
2. Select the type(s) of enhancements to apply and drag the sliders to adjust the level for each enhancement.
3. Click  to test the audio output, if necessary.
4. Click **Save** to save the adjusted settings or **Reset** to restore default settings.

SBX Pro Studio includes a number of enhancements for movies and gaming, elevating your movie and gaming experience to the next level. These include:

- **SBX Surround** - this technology provides immersion control to enhance the natural sense of audio depth and spaciousness by creating virtual surround sound channels. Stereo content or multichannel content will sound as if its coming from all sides while voices remain centered in front and original balance and timbre is preserved.
- **SBX Crystalizer** - restores the natural dynamic range that is lost when music files (iTunes and MP3) gets compressed. This makes the music sound as good as the artist originally intended, and adds an enhanced level of realism for movies and games.
- **SBX Bass** - fills in the missing low frequency tones and gives the extra impact for a better entertainment experience. Consumers no longer have to tolerate a lack of bass in speakers as the SBX Pro Studio Bass technology dramatically improves the sound experience even in the absence of a subwoofer.
- **SBX Smart Volume** - addresses the problem of abrupt volume level changes during playback and between songs by continuously measuring volume automatically, applying gain and attenuation intelligently to compensate for any changes.
- **SBX Dialog Plus** - enhances the voices in movies for clearer dialog, allowing the listener to hear the dialog over the rest of the soundtrack and over ambient noise in the listening environment.

Equalizer Settings

From the **SBX Pro Studio** screen, click **Equalizer** to configure equalizer settings.

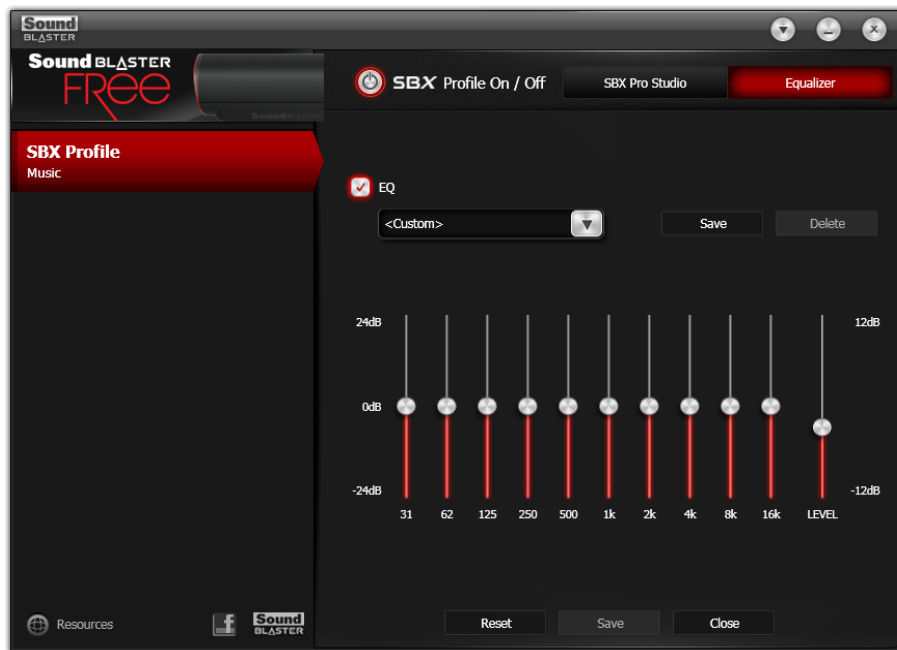

To adjust and apply an equalizer preset,

1. Check the **EQ** checkbox to enable the use of the equalizer.
2. From the drop down menu, select the preset to use.
3. Adjust the vertical slider bars to achieve your desired level.
4. Click **Save** to save the changes to the active preset or to a new preset.

You can also delete any user created equalizer presets by selecting the preset from the drop down menu and clicking **Delete**.

Note:

All default equalizer presets cannot be deleted.

General Specifications

Controls and Indicators

Top Panel

- *Bluetooth* LED indicator
- Phone/*Bluetooth* button
- Volume + button
- Volume - button
- Power button
- Battery status indicator

Music Player

- LOUD button
- Play/Pause button
- Shuffle/Repeat All button
- Next/Previous button
- Mic Mute button

Input/Output

- Built-in microphone
- Micro-USB port
- Aux-in jack
- MicroSD slot
- Rear passive radiator

Physical Specifications

- Dimensions (L x W x H) : 68.5 x 71.1 x 200.8 mm
- Weight: Approx. 446 g

Technical Specifications

Bluetooth Version: *Bluetooth* 4.0

Bluetooth Profiles:

- A2DP (*Wireless Stereo Bluetooth*)
- AVRCP (*Bluetooth* Remote Control)
- HFP (*Hands-Free Profile*)
- HSP (*Headset Profile*)

Bluetooth Operating Frequency: 2402 - 2480 MHz

Bluetooth Operating Range: Up to 10 meters / 33 feet
(Measured in open space. Walls and structures may affect range of device.)

Audio Codec: FastStream, SBC

Operating Temperature range: 0°C to 45°C

Lithium Ion Battery: 3.7 V  2200 mAh

Power Input: DC 5 V, 1 A

Note:

Compliance markings are located on the rear of this product.

*The serial number for your Sound Blaster FRee is located on the warranty leaflet.
Please write the serial number down and keep it in a secure place.*

Troubleshooting and Support

This chapter provides solutions to issues that may be encountered during the installation or usage of your Sound Blaster FRee.

1. The Sound Blaster FRee does not power on.

The Sound Blaster FRee is designed to be powered on simply by the built-in battery. Make sure that it is charged. When charging the battery, check the following:

- Tighten the USB connection at both ends of the cable.
- The USB cable may be faulty. Replace the cable with a working USB cable.
- Your computer's USB port may be disabled, or faulty or requires a driver update. Check your computer's hardware device manager to determine the working status of your USB port. Enable your USB port and/or update its driver.

If the problem persists, connect the Sound Blaster FRee to a different USB port.

If you are connected via a USB Power Adapter, please check that all cables are tightly connected and the power socket is turned on.

2. I am having difficulty in linking up my *Bluetooth* device with Sound Blaster FRee.

Ensure that your *Bluetooth* enabled device supports A2DP profile.

Please also try the following steps:

- Make sure that *Bluetooth* is enabled (turned on) on your device.
- On some devices, ensure that the Sound Blaster FRee is selected as the default headset / wireless stereo audio playback device.
- Make sure that there are no other wireless devices within a 10 meter radius when pairing.
- Position them within 1 meter or closer to each other if you experience pairing difficulties.
- Check if you have input the correct passcode/pin number (0000) on your *Bluetooth* device.
- Ensure that both, your *Bluetooth* device and Sound Blaster FRee are not connected to any other devices.
- Restart your *Bluetooth* device or pair the devices again.

3. *Bluetooth* link is established and paired between the devices but there's no music.

Ensure that the device's volume is not set to minimum. Also, make sure that the built-in music player is not in use.

With some built-in *Bluetooth* enabled computers or 3rd party USB *Bluetooth* dongles, you may be required to manually specify/set-up the audio output as the Sound Blaster FRee (under sound and audio devices section) on your computer's operating system.

Note:

Audio transmitted from your Sound Blaster FRee may be slightly delayed; this is due to the characteristics of Bluetooth technology.

4. There is no audio output from the Sound Blaster FRee.

Check speaker connection:

- Make sure *Bluetooth* is turned on and in range.
- Unplug the USB cable from the computer and plug it in again.
- Make sure the cable from your line-in device is properly plugged in.
- Ensure that the format of the audio files from the SD card is supported.

Check volume level:

- The volume of Sound Blaster FRee is at the appropriate level.
- Master volume and mute icon on the software is at the appropriate level.
- The appropriate channel(s) and output types on the **Mixer** settings interface is not 0.

5. What are the types of microSD cards supported?

All microSD, microSDHC and microSDXC cards of up to 32GB in FAT16 or FAT32 format are supported for audio playback.

6. Some of my music files on the microSD card cannot be played back.

Ensure that the media files being played back are in MP3, WAV or FLAC format.

For optimal playback, you are not advised to store more than 999 music files in each folder on your microSD card. Reorganize files into different folders so that all your music files can be played back.

7. How can I reset the speaker to factory default settings?

Press and hold the Power and Phone/*Bluetooth* buttons for more than 2 seconds to reset speaker settings to the initial settings. The speaker then shuts down and restarts automatically.

Additional Support

If you encounter any other issues or have any other enquiries about your Sound Blaster FRee or any other Creative products, please visit our comprehensive knowledge base at support.creative.com or www.soundblaster.com for additional information.

Regulatory Information

The following sections contains notices for various countries.

Caution:

This product is intended for use with FCC/CE certified computer equipment. Please check the equipment operating/installation manual and/or the equipment manufacturer to verify/confirm if your equipment is suitable prior to the installation or use of the product.

Notice for the USA

Federal Communication Commission (FCC) Interference Statement

FCC PART 15: This equipment has been tested and found to comply with the limits for a Class B digital device, pursuant to Part 15 of the FCC Rules. These limits are designed to provide reasonable protection against harmful interference in a residential installation. This equipment generates, uses and can radiate radio frequency energy and, if not installed and used in accordance with the instructions, may cause harmful interference to radio communications. However, there is no guarantee that interference will not occur in a particular installation. If this equipment does cause harmful interference to radio or television reception, which can be determined by turning the equipment off and on, the user is encouraged to try to correct the interference by one or more of the following measures:

- Reorient or relocate the receiving antenna.
- Increase the separation between the equipment and receiver.
- Connect the equipment into an outlet on a circuit different from that to which the receiver is connected.
- Consult the dealer or an experienced radio/TV technician for help.

This device complies with part 15 of the FCC Rules. Operation is subject to the following two conditions:

1. This device may not cause harmful interference, and
2. This device must accept any interference received, including interference that may cause undesired operation.

Caution:

To comply with the limits of the Class B digital device, pursuant to Part 15 of the FCC Rules, this device must be installed with computer equipment certified to comply with Class B limits.

All cables used to connect to the computer and peripherals must be shielded and grounded. Operation with non-certified computers or non-shielded cables may result in interference to radio or television reception.

MODIFICATION: Any changes or modifications not expressly approved by the grantee of this device could void the user's authority to operate the device.

Federal Communication Commission (FCC) Radiation Exposure Statement

This equipment complies with FCC radiation exposure limits set forth for an uncontrolled environment. This transmitter must not be co-located or operating in conjunction with any other antenna or transmitter.

Notice for Canada

This Class B digital apparatus complies with Canadian ICES-003 and RSS-210.

Cet appareil numérique de classe B est conforme aux normes canadiennes NMB-003 et CNR-210.

This device complies with Industry Canada licence-exempt RSS standard.

Operation is subject to the following two conditions:

1. This device may not cause harmful interference, and
2. this device must accept any interference received, including interference that may cause undesirable operation.

Cet appareil est conforme avec Industrie Canada RSS standard exempts de licence.

Son fonctionnement est soumis aux deux conditions suivantes :

1. Le matériel ne peut être source D'interférences et
2. Doit accepter toutes les interférences reçues, Y compris celles pouvant provoquer un fonctionnement indésirable.

CANADIAN CLASS B STATEMENT: This digital device does not exceed the Class B limits for radio noise emissions from digital apparatus as set out in the interference-causing equipment standard entitled "Digital Apparatus," ICES-003 of the Department of Communications.

Cet appareil numérique respecte les limites de bruits radioélectriques applicables aux appareils numériques de Classe B prescrites dans la norme sur le matériel brouilleur: "Appareils Numériques," NMB-003 édictée par le ministre des Communications.

MODIFICATION: Any changes or modifications not expressly approved by the grantee of this device could void the user's authority to operate the device.

Toute modification non approuvée explicitement par le fournisseur de licence de l'appareil peut entraîner l'annulation du droit de l'utilisateur à utiliser l'appareil.

European Compliance



This product conforms to the following:

RoHS Directive 2011/65/EU.

EMC Directive 2004/108/EC.

Mains operated products for the European market comply with Low Voltage Directive 2006/95/EC and Commission Regulation(s) Implementing Directive 2009/125/EC.

Communication / RF wireless products for the European market comply with R&TTE Directive 1999/5/EC.

CAUTION: To comply with the Europe CE requirement, this device must be installed with CE certified computer equipment which meet with Class B limits.

All cables used to connect this device must be shielded, grounded and no longer than 3m in length. Operation with non-certified computers or incorrect cables may result in interference to other devices or undesired effects to the product.

MODIFICATION: Any changes or modifications not expressly approved by Creative Technology Limited or one of its affiliated companies could void the user's warranty and guarantee rights.

[FR] European Compliance

Ce produit est conforme aux normes suivantes :

Directive 2004/108/CE sur les émissions électromagnétiques.

Directive RoHS 2011/65/UE.

Les produits secteur pour le marché européen sont conformes à la Directive sur la faible tension 2006/95/CE et à la réglementation de la Commission exécutant la Directive 2009/125/CE.

Les produits de communication/sans fil RF destinés au marché européen sont conformes à la directive R&TTE 1999/5/CE.

ATTENTION : pour respecter les critères CE d'Europe, cet appareil doit être installé avec du matériel informatique certifié CE respectant les limites de la classe B. Tous les câbles utilisés pour connecter cet appareil doivent être blindés, reliés à la terre et ne pas faire plus de 3 m de long. L'utilisation d'ordinateurs non certifiés ou de câbles inappropriés peut entraîner des interférences avec d'autres appareils ou des effets indésirables sur le produit.

MODIFICATION : toute modification non approuvée explicitement par Creative Technology Limited ou l'une de ses sociétés affiliées peut entraîner l'annulation de la garantie et des droits de garantie de l'utilisateur.

[IT] Conformità alle normative europee

Questo prodotto è conforme alla seguente normativa:

Direttiva EMC 2004/108/CE.

Direttiva RoHS 2011/65/UE.

I prodotti che funzionano con corrente di rete per il mercato europeo sono conformi alla direttiva bassa tensione 2006/95/CE e alla direttiva di implementazione nelle normative europee 2009/125/CE.

I prodotti di comunicazione/wireless RF per il mercato europeo sono conformi alla Direttiva R&TTE 1999/5/CE.

ATTENZIONE: ai fini della conformità con i requisiti del marchio CE europeo, il dispositivo deve essere installato in un computer certificato CE conforme ai limiti di Classe B. Tutti i cavi usati per collegare il

dispositivo devono essere schermati, dotati di idonea messa a terra e avere una lunghezza massima di 3 metri. L'uso del dispositivo con computer non certificati o cavi non idonei può provocare interferenze ad altri dispositivi nonché danneggiare il prodotto stesso.

MODIFICHE: eventuali modifiche o alterazioni non espressamente approvate da Creative Technology Limited o dalle sue società controllate possono rendere nulli la garanzia e il diritto dell'utente a utilizzare il prodotto.

[DE] Einhaltung der europäischen Bestimmungen

Dieses Produkt erfüllt die folgenden Bestimmungen:

EMC-Richtlinie 2004/108/EG.

RoHS-richtlinie 2011/65/EU.

Netzbetriebene Produkte für den europäischen Markt erfüllen die Niederspannungsverordnung 2006/95/EG und der Commission Regulation(s) Implementing-Verordnung 2009/125/EG.

Drahtlose Kommunikationsgeräte/Funksender und -empfänger für den europäischen Markt erfüllen die R&TTE-Richtlinie 1999/5/EG.

ACHTUNG: Um die Anforderungen der europäischen CE-Norm zu erfüllen, muss dieses Produkt an einem CE-geprüften Computer der Klasse B angeschlossen werden. Alle Verbindungskabel zu diesem Gerät müssen abgeschirmt und geerdet sein und dürfen nicht länger als 3 m sein. Der Betrieb mit nicht zertifizierten Computern oder nicht ordnungsgemäßen Kabeln kann zu Störungen anderer Geräte oder unerwünschten Auswirkungen auf das Produkt führen.

MODIFIZIERUNG: Jegliche Änderung oder Modifizierung des Produkts, die nicht ausdrücklich von Creative Technology Limited oder einer der zugehörigen Firmen genehmigt worden ist, kann für den Benutzer zum Erlöschen der Garantie und der Gewährleistungsrechte führen.

[ES] Homologación para Europa

Este producto cumple:

la Directiva de compatibilidad electromagnética 2004/108/CE.

Directiva RoHS 2011/65/UE.

Los productos funcionando con corriente eléctrica cumplen con la Directiva 2006/95/CE de baja tensión y con la implementación de los requisitos de la Comisión para la directiva 2009/125/CE.

Los productos inalámbricos de comunicación o frecuencias de radio para el mercado europeo cumplen la Directiva 1999/5/CE de equipos de radio y terminales de telecomunicaciones.

ATENCIÓN: para cumplir con los requisitos de Homologación para Europa, este dispositivo debe instalarse con un equipo informático con certificación CE que cumpla los límites de la Clase B. Todos los cables utilizados para conectar este dispositivo deben estar protegidos, conectados a tierra y no tener más de 3 m de longitud. El funcionamiento del dispositivo con equipos no certificados o cables incorrectos podría provocar interferencias a otros dispositivos o efectos no deseados al producto.

MODIFICACIÓN: los cambios o modificaciones no aprobados expresamente por Creative Technology Limited o una de sus empresas afiliadas podrían invalidar la garantía del usuario y los derechos de la garantía.

[NL] Europese naleving

Dit product voldoet aan de volgende voorschriften:

EMC-richtlijn 2004/108/EG.

RoHS-richtlijn 2011/65/EU.

Electrische producten voor de Europese markt voldoen aan de Laagspanningsrichtlijn 2006/95/EG en EC and Verordening(en) voor uitvoering van Richtlijn 2009/125/EG.

Communicatie- of draadloze RF-producten voor de Europese markt voldoen aan de richtlijn R&TTE 1999/5/EG.

LET OP: Om te voldoen aan de Europese CE-norm, moet dit apparaat zijn geïnstalleerd in computerapparatuur die CE-gecertificeerd is voor de Klasse B-limieten. Alle kabels die worden gebruikt om dit apparaat aan te sluiten, moeten zijn afgeschermd en geaard, en mogen niet langer dan 3 meter zijn. Gebruik met niet-gecertificeerde computers of incorrecte kabels kan leiden tot interferentie van andere apparaten of ongewenste effecten op het product.

AANPASSING: Alle wijzigingen of modificaties die niet uitdrukkelijk zijn goedgekeurd door Creative Technology Limited of een van de gelieerde maatschappijen, kunnen ertoe leiden dat de rechten van de gebruiker met betrekking tot garantie en vrijwaring vervallen.

[PT] Conformidade Europeia

Este produto está em conformidade com a seguinte regulamentação:

Directiva EMC 2004/108/EC.

Directiva RoHS 2011/65/UE.

Os produtos com ligação à rede destinados ao mercado europeu estão em conformidade com a directiva de baixa voltagem 2006/95/CE. Directiva de Implementação do(s) Regulamento(s) da Comissão 2009/125/CE.

Os produtos de comunicação/radiofrequência sem fios destinados ao mercado europeu estão em conformidade com a directiva R&TTE 1999/5/CE.

ATENÇÃO: De modo a cumprir com os requisitos da marca CE Europeia, este dispositivo deve ser instalado com equipamento informático com certificação CE que cumpra com os limites de Classe B limits. Todos os cabos usados para ligar este dispositivo devem ser blindados, ligados à terra e não devem exceder os 3m de comprimento. O funcionamento com computadores não certificados ou cabos incorrectos pode resultar em interferências em outros dispositivos ou provocar efeitos indesejados no produto.

MODIFICAÇÃO: Quaisquer alterações ou modificações que não sejam expressamente aprovadas pela Creative Technology Limited ou por uma das suas afiliadas, pode anular a garantia do utilizador e os direitos inerentes à mesma.

[SV] Europeisk efterlevnad

Denna produkt uppfyller följande:

EMC-direktivet 2004/108/EC.

RoHS Direktivet 2011/65/EU.

Produkter för den europeiska marknaden som drivs via elnätet uppfyller Lågspänningsdirektivet 2006/95/EC och Kommissionens regleringsimplementeringsdirektiv 2009/125/EG.

Trådlösa kommunikations/RF-produkter för den europeiska marknaden uppfyller R&TTE-direktivet 1999/5/EC.

VARNING: För att uppfylla CE-kraven i Europa måste denna produkt installeras med CE-certifierad datorutrustning som uppfyller gränsvärdena för klass B. Alla kablar som används för anslutning av denna produkt måste vara avskärmade, jordade och får inte vara längre än 3 m. Användning med icke certifierade datorer eller felaktiga kablar kan leda till interferens på annan utrustning eller oönskade effekter på produkten.

MODIFIERING: Alla förändringar och modifieringar som inte är uttryckligen tillåtna av Creative Technology limited eller något av dess filialföretag kan göra användarens garanti och garantirättigheter ogiltiga.

[NO] Europeisk samsvar

Dette produktet er i samsvar med følgende:

EMC-direktivet 2004/108/EC.

RoHS-Direktivet 2011/65/EU.

Elektriske produkter til det europeiske markedet er i samsvar med Lavspenningsdirektivet 2006/95/EC og Økodesigndirektivet 2009/125/EC.

Kommunikasjon/RF trådløse produkter til det europeiske markedet er i samsvar med R&TTEdirektivet 1999/5/EC.

ADVARSEL: For å overholde det europeiske CE-kravet må denne enheten installeres med CEsertifisert datautstyr som tilfredsstillers klasse B-grensene. Alle kabler som kobles til enheten må være skjermet, jordet og ikke lenger enn 3 m i lengde. Bruk av ikke-sertifiserte datamaskiner eller feil kabler kan føre til forstyrrelse av andre enheter eller uønsket effekt på produktet.

MODIFIKASJON: Eventuelle endringer eller modifikasjoner som ikke uttrykkelig er godkjent av Creative Technology Limited eller et av dets tilknyttede selskaper, kan ugyldiggjøre garantien eller garantirettighetene.

[DK] Overholdelse af Europæiske regler og standarder

Dette produkt overholder følgende:

EMC-direktivet 2004/108/EC.

RoHS-Direktivet 2011/65/EU.

Produkter til det Europæiske marked, skal overholde Lavspændingsdirektivet 2006/95/EC og Kommissionens forordninger for implementering af direktivet 2009/125/EF.

Kommunikations- / RF-trådløse produkter til det Europæiske overholder R&TTE-direktivet 1999/5/EC.

ADVARSEL: For at overholde Europe CE-kravet, skal denne enheden installeres med CE-certificeret computerudstyr, der opfylder klasse B-grænserne. Alle kabler der anvendes til at tilslutte enheden skal være skærmede, jordforbundne og ikke længere end 3 m lange. Drift med ikke-certificerede computere og ukorrekte kabler kan medføre interferens for andre enheder eller uønskede effekter på produktet.

MODIFIKATION: Enhver ændring eller modifikation, der ikke er udtrykkeligt godkendt af Creative Technology Limited eller et associerede selskab, vil gøre brugerens garanti og garanterede rettigheder ugyldig.

[FI] Eurooppalainen yhdenmukaisuus

Tämä tuote täyttää seuraavat tuotemääritykset:

EMC-direktiivin 2004/108/EC.

RoHS-direktiivin 2011/65/EU.

Euroopan markkinoiden verkkovirtaa käyttävät tuotteet ovat matalajännittdirektiivin 2006/95/EY mukaisia. Euroopan parlamentin ja neuvoston ohjaava direktiivi 2009/125/EY.

Euroopan markkinoiden tietoliikenne- ja langattomat radiotaajuustuotteet noudattavat R&TTEdirektiiviä 1999/5/EY.

VAROITUS: Jotta tämä laite noudattaisi Euroopan CE-vaatimuksia , tämä laite on asennettava CEsertifioituun tietokoneeseen, joka noudattaa luokan B rajoituksia. Kaikki tämän laitteen liittäminen käytetyt kaapelit tulee suojata ja maadoittaa eivätkä ne saa olla 3 m pidempiä. Luokan rajoituksia noudattamattoman tietokoneen tai vääränlaisten kaapeleiden käyttäminen voi aiheuttaa häiriötä muihin laitteisiin tai haitata itse laitteen toimintaa.

MUOKKAUKSET: Muutokset tai muokkaukset, joita Creative Technology Limited tai sen tytäryhtiöt eivät nimenomaisesti ole hyväksyneet, voivat mitätöidä tuotteelle annetun takuun.

[CZ] Evropská shoda

Tento výrobek splňuje následující směrnice:

Směrnice EMC 2004/108/EC.

Směrnice RoHS 2011/65/EU.

Výrobky napájené z elektrické zásuvky pro evropský trh splňují směrnici o nízkém napětí 2006/95/EC a směrnici komise 2009/125/EC o zavádění předpisů.

Komunikační / vysokofrekvenční bezdrátové výrobky pro evropský trh splňují směrnici R&TTE 1999/5/EC.

UPOZORNĚNÍ: Aby toto zařízení splňovalo evropský požadavek CE, musí být nainstalováno s počítačovým vybavením s certifikátem CE, které splňuje limity pro zařízení třídy B. Veškeré kabely používané pro připojení tohoto zařízení musí být stíněné, uzemněné a nesmí být delší než 3 metry. Při používání s necertifikovanými počítači nebo nesprávnými kabely může dojít k rušení jiných zařízení nebo k nežádoucím vlivům na produkt.

ÚPRAVY: Jakékoli změny nebo úpravy, které nebyly vysloveně schváleny společností Creative Technology Limited nebo některou z jejích dceřiných společností, mohou způsobit propadnutí záruky uživatele a záručních práv.

[PL] Zgodność z przepisami europejskimi

Urządzenie jest zgodne z

dyrektywą EMC 2004/108/EC.

Dyrektywa RoHS 2011/65/UE.

Urządzenia zasilane z sieci elektrycznej przeznaczone na rynek europejski muszą być zgodne z dyrektywą dotyczącą urządzeń niskonapięciowych 2006/95/EC oraz z dyrektywą wdrażającą komisji regulacyjnej 2009/125/WE.

Urządzenia komunikacyjne / bezprzewodowe wykorzystujące transmisję radiową przeznaczone na rynek europejski spełniają warunki dyrektywy RTTE 1999/5/EC.

UWAGA: Aby uzyskać zgodność z wymogami europejskiej normy CE urządzenie musi być zainstalowane wraz ze sprzętem komputerowym mającym certyfikat CE z ograniczeniami klasy B. Wszystkie przewody używane do podłączania niniejszego urządzenia muszą być ekranowane, uziemione i nie dłuższe niż 3 metry. Użytkowanie z komputerami nie posiadającymi certyfikatów lub wykorzystanie niewłaściwych przewodów może powodować zakłócenia pracy innych urządzeń lub opisywanego urządzenia.

MODYFIKACJE: Dokonanie jakichkolwiek zmian lub modyfikacji, na które firma Creative Technology Limited lub spółki z nią stowarzyszone nie udzielają wyraźnej zgody, może doprowadzić do unieważnienia praw gwarancji i rękojmi użytkownika.

[HU] Európai megfelelés

Ez a termék megfelel a következőknek:

2004/108/EGK sz., az elektromágneses összeférhetőségre. 2011/65/EU, RoHS.

Az Európa területére szánt hálózati termékek megfelelnek az alacsony feszültségre vonatkozó 2006/95/EC irányelvnek.

Az irányelvet 2009/125/EK végrehajtó bizottsági rendeletek.

Az Európa területére szánt, távközlési, illetve rádiófrekvenciás vezeték nélküli termékek megfelelnek a rádiós távközlő végberendezésekre vonatkozó 1999/5/EK irányelvnek.

FIGYELEM! Az európai CE követelmények teljesítéséhez ezt a készüléket a B kategóriájú értékeknek megfelelő, CE minősítésű számítógéppel együtt kell telepíteni. A készülék csatlakoztatására használt valamennyi kábelnek árnyékoltnak és földeltnek kell lennie, továbbá hosszúsága nem haladhatja meg a 3 métert. A nem hitelesített számítógépekkel vagy helytelen kábelekkel való használat más készülékek zavarását vagy a termék nem kívánatos befolyásolását okozhatja.

MÓDOSÍTÁS: Minden módosítás vagy változtatás, amit kifejezetten nem hagyott jóvá a Creative Technology Limited vagy valamelyik leányvállalata, érvénytelenítheti a készülék garanciáját és felhasználó garanciális jogait.

[EL] Európaïkë szumórfwsh

To parón proïón szumorfwntai me ta parakátw:

Odhgia HMs 2004/108/EK.

Odhgia RoHS 2011/65/EE.

Ta proïonta pou leitourgwón me reýma gia την eurwpaïkë agora szumorfwntai me την Odhgia peri xamhlihs tássh 2006/95/EK kai tous kanonismwús thsh epitropihsh pou ulopoioýn την odhgia 2009/125/EK.

Ta asýrmeta proïonta epikoinwoniwón / RF gia την eurwpaïkë agora szumorfwntai me την odhgia R&TTE 1999/5/EK.

ΠΡΟΣΟΧΗ: Για τη szumórfwsh me tis απαιτήshsh του eurwpaïkú CE, autë η szuskeuh θα prëpei na eghkatastathë se exoplismó upologισtë me πιστοποίηση CE o opoïos plhroí ta ória thsh katighorías B. Όλα ta kalwðia pou xrhshmoipoioýntai gia τη σύνδεση thsh szuskeuhsh θα prëpei na einai thwρακισμένα, ghwωμένα kai na mhν υπερβαίνουn σε mhkosh ta 3m. Η leitourgia me mh πιστοποιημένους upologισtés ή λάθος kalwðia mporeí na odhghsh se παρεμβολés me άλλες szuskeués ή ανεπιθύμητες επιδράshsh στο proïón.

ΤΡΟΠΟΠΟΙΗΣΗ: Οι óποιες αλλαγés ή τροποποιήshsh pou den échoun eghkritheí rhtá apó την Creative Technology Limited ή kápoia apó tis thγατρικές thsh ενδέχεται na akurwswou την eghghsh του xrhsth kai ta dikaiwματα pou aporréoun apó autēn

[LT] Europos Sajungos atitiktis

Šis gaminys atitinka šiuos reikalavimus:

„Elektromagnetinės atitikties“ („EMC“) direktyva 2004/108/EC.

RoHS direktyva 2011/65/ES.

Produktai, kurie veikia maitinami iš elektros tinklo, skirti Europos rinkai, atitinka Žemos įtampos direktyvą 2006/95/EB.

Komisijos reglamentas(-ai) dėl Direktyvos 2009/125/EB įgyvendinimo.

Europos Sajungos rinkai skirti ryšiu / radijo dažnių bevieliai gaminiai atitinka 1999/5/EB direktyvą „Dėl radijo ryšio įrenginių ir telekomunikacijų galinių įrenginių bei abipusio jų atitikties pripažinimo“.

ATSARGIAI: Tam, kad šis prietaisas atitiktų Europos Sajungos „CE“ reikalavimus, jis turi būti įdiegtas į „CE“ sertifikuotą kompiuterinę įrangą, atitinkančią „B“ klasės ribas. Visi su šiuo prietaisu naudojami laidai turi būti ekranuoti, įžeminti ir neviršyti 3 m ilgio. Nesertifikuotų kompiuterių ar netinkamų laidų

naudojimas gali tapti trikdžių kitiems prietaisams arba nepageidaujamų šio gaminio veikimo pasekmių priežastimi.

MODIFIKAVIMAS: Bet kokie pakeitimai ar modifikavimai neturint aiškiai patvirtinto „Creative Technology Limited“ ar vienos iš su ja susijusių bendrovių leidimo gali panaikinti vartotojo garantiją ir garantijos teises.

[SK] Dodržiavanie predpisov Európskej únie

Tento výrobok spĺňa nasledujúce normy:

Smernica EMC 2004/108/ES.

Smernica RoHS 2011/65/EÚ.

Výrobky napájané zo siete určené na európsky trh sú v súlade so smernicou o harmonizácii právnych predpisov členských štátov týkajúcich sa elektrického zariadenia určeného na používanie v rámci určitých limitov napätia 2006/95/ES a s nariadeniami Komisie, ktorými sa vykonáva smernica 2009/125/ES.

Bezdrôtové komunikačné/RF výrobky určené na európsky trh sú v súlade so smernicou R&TTE 1999/5/ES.

VAROVANIE: Toto zariadenie musí byť nainštalované s počítačovým zariadením s certifikáciou CE, ktoré spĺňa limity triedy B, aby bolo v súlade s európskymi požiadavkami CE. Všetky káble použité na pripojenie tohto zariadenia musia byť tienené, uzemnené a nie dlhšie ako 3 m. Prevádzka pomocou necertifikovaných počítačov alebo nesprávnych káblov môže mať za následok rušenie iných zariadení alebo nežiaduce účinky na výrobok.

ÚPRAVY: Akékoľvek zmeny alebo úpravy, ktoré neboli výslovne odsúhlasené spoločnosťou Creative Technology Limited alebo jednou z jej sesterských spoločností, môžu zrušiť platnosť záruky a záručných práv používateľa.

[RU] Соответствие европейским нормам

Данное изделие соответствует следующим стандартам:

EMC Директива 2004/108/ЕС.

RoHS директива 2011/65/EU.

Продукция с питанием от сети, поставляемая на европейский рынок, соответствует Директиве по низковольтному оборудованию 2006/95/ЕС и Имплементирующей директиве постановления (- й) комиссии 2009/125/ЕС.

Коммуникационное/радио- беспроводное оборудование, поставляемое на европейский рынок, соответствует Директиве по окончному радио- и телекоммуникационному оборудованию 1999/5/ЕС.

ВНИМАНИЕ! Для обеспечения соответствия европейским требованиям CE, это устройство должно устанавливаться с компьютерным оборудованием, сертифицированным по стандарту CE и удовлетворяющим нормам класса B. Все кабели, используемые для подключения данного устройства, должны быть экранированы, заземлены и иметь длину не более 3 м. Работа с несертифицированными компьютерами или неподходящими кабелями может привести к возникновению помех другим устройствам или негативному влиянию на работу самого изделия.

ИЗМЕНЕНИЯ КОНСТРУКЦИИ Любые изменения конструкции, на которые не было получено прямое разрешение компании Creative Technology Limited или ее дочерней компании, может привести к аннуляции гарантии и связанных с ней прав.

[TR] Avrupa Uyumu

Bu ürün aşağıdakilere uygundur:

2004/108/EC EMC (Elektromanyetik Uyumluluk) Yönetmeliđi.

2011/65/EU RoHS (Tehlikeli Maddelerin Kısıtlanması) Yönetmeliđi

Avrupa piyasasına yönelik, elektrik şebekesi tarafından çalıştırılan ürünler 2006/95/EC Alçak Gerilim Yönetmeliđi (LVD) ve 2009/125/EC Enerji ile İlgili Ürünlerin Çevreye Duyarlı Tasarımına İlişkin Yönetmeliđe uygundur.

Avrupa piyasasına yönelik İletişim / RF kablosuz ürünleri Yönetmelik R&TTE 1999/5/EC ile uyumludur.

DİKKAT: Avrupa CE gereksinimleriyle uyumlu olması için bu cihazın, B Sınıfı sınırlarına uygun olan CE sertifikalı bilgisayar donanımları ile birlikte kurulması gerekir. Bu cihazı bağlamak için kullanılan tüm kabloların koruyuculu ve topraklanmış olması ve 3 metreden uzun olmaması gerekir. Sertifikalı olmayan bilgisayarlarla veya yanlış kablolarla birlikte kullanılması, diđer cihazların düzgün çalışmamasına veya üründe istenmeyen etkiler görülmesine neden olabilir.

DEĐİŞİKLİKLER: Creative Technology Limited veya bađlı şirketlerinden biri tarafından açıkça onaylanmamış tüm deđişiklikler kullanıcının garanti ve teminat haklarını geçersiz kılabilir.

Notice for Singapore

Complies with
IDA Standards
DB00148

Notice for Japan

Recycling Rechargeable Battery



Li-ion

Lithium rechargeable battery is a resource that can be recycled.

- For recycling of embedded lithium rechargeable batteries inside Creative products, please do not attempt to remove the battery from the device. For recycling information and instruction, please go to Creative Media K K customer support at <http://jp.creative.com/support/contact/> (in Japanese)
- For recycling of replaceable (removable) lithium rechargeable batteries:



注意事項

- It is recommended to remove the rechargeable batteries when they are fully discharged.
- Precaution needs to be taken on metal parts of the battery by covering them with isolation materials such as scotch tape.
- Refer to the homepage of JBRC for information on recycling and recovery of rechargeable batteries and supporting shops. (<http://www.jbrc.com/>)

Notice for Korea

B급 기기

(가정용 방송통신기자재)

이 기기는 가정용 (B급) 전자파적합 기기로서 주로 가정에서 사용하는 것을 목적으로 하며, 모든 지역에서 사용할 수 있습니다.

Safety Information

Refer to the following information to use your product safely, and to reduce the chance of electric shock, short-circuiting, damage, fire, hearing impairment or other hazards. Improper handling may void the warranty for your product. For more information, read the warranty available with your product.

- Do not dismantle or attempt to repair your product.
Refer all servicing to authorized repair agents.
- Do not expose your product to temperatures outside the range of 0°C to 45°C (32°F to 113°F).
- Do not pierce, crush or set fire to your product.
- Keep your product away from strong magnetic objects.
- Do not subject your product to excessive force or impact.
- Do not expose your product to water or moisture.
If your product is moisture-resistant, take care not to immerse your product in water or expose it to rain.

Bluetooth Product

- The short wave radio frequency signals of a *Bluetooth* device may impair the operation of other electronic and medical devices.
- Switch off the device where it is prohibited. Do not use the device in medical facilities, aircraft, refueling points, close to automatic doors, automatic fire alarms or other automatically controlled devices.
- Keep this device at least 20 cm from pacemakers and other medical devices. Radio waves may impair the operation of pacemakers and other medical devices.

Embedded Battery

- Do not attempt to remove the embedded battery.
The product must be disposed of according to local environmental regulations. To replace the battery, return your product to your regional support office. For product service information, go to www.creative.com.
- Do not expose to excessive heat such as sunlight, fire or the like.
CAUTION: Risk of explosion if battery is replaced by incorrect types.

Safe Removal of Built-in Battery

This product contains an integrated battery which should ONLY be removed by service centers or recycling facilities with reference to the instructions herein. Creative and its affiliates will not be liable for any damages resulting from attempting to remove and/or tampering with the battery or any part of the product by an end user.

CAUTION:

"Make sure the product is disconnected from the charging cable before removing the battery"

"Cover one of the battery terminals with insulation tape to prevent short circuit" - not applicable to battery with connector

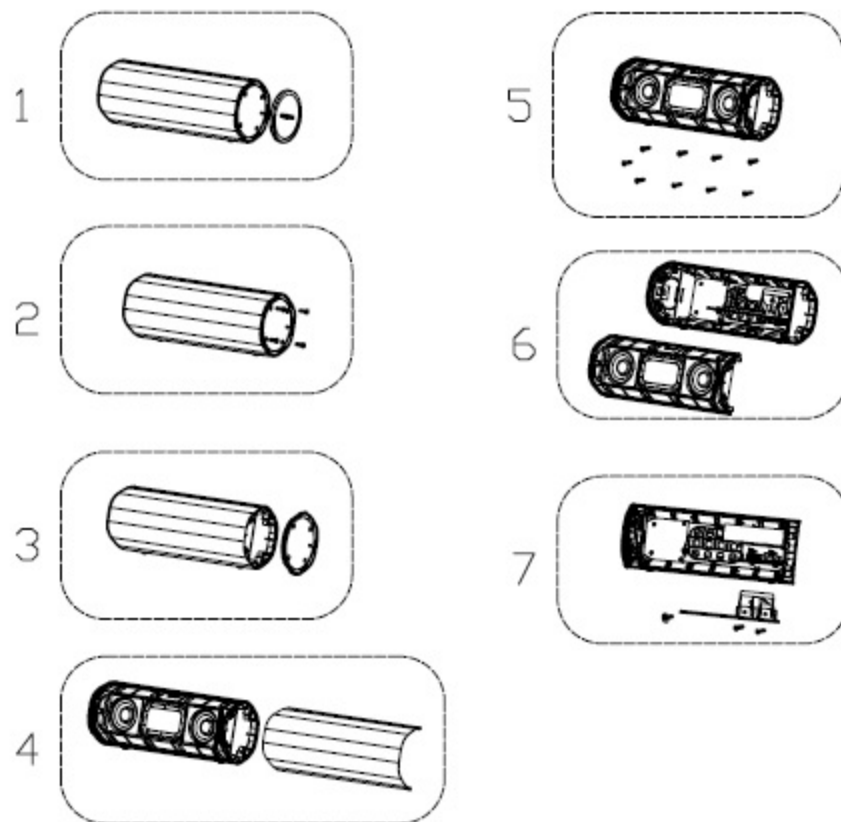

Battery removal instruction:

1. Remove rubber pad from the right side of the speaker.
2. Unfasten the 4 screws on the red cover.
3. Remove the red cover.
4. To remove metal grill, slide it out from the right side.
5. Unfasten the 9 screws on the front cover.
6. Remove the front cover.
7. Remove the PCBA by disconnecting the battery cable and unfastening the 3 screws on it. Then, remove the battery.

[FR] Démontage sécurisé de la batterie intégrée

Ce produit contient une batterie intégrée qui ne devrait être démontée que par des centres de services ou des installations de recyclage en référence aux instructions indiquées dans ce document. Creative et

ses sociétés affiliées ne seront pas responsables de tout dommage résultant de votre essai de démonter et / ou altérer la batterie ou une partie du produit par un utilisateur final.

ATTENTION:

« Assurez-vous que le produit est déconnecté du câble de chargement avant de démonter la batterie ».

« Couvrez une des bornes de la batterie avec du ruban isolant pour éviter un court-circuit » - Cela ne s'applique pas à la batterie avec connecteur.

Instructions du démontage de la batterie:

1. Retirez le coussinet en caoutchouc du côté droit de l'enceinte.
2. Desserrez les vis du couvercle rouge.
3. Retirez le couvercle rouge.
4. Faites glisser la grille métallique située sur le côté droit.
5. Desserrez les vis du couvercle avant.
6. Retirez le couvercle avant.
7. Retirez la sortie de câble batterie du circuit imprimé principal. Desserrez les vis et retirez le circuit imprimé principal. Retirez ensuite la batterie.

[IT] Rimozione sicura della batteria integrata

Il prodotto contiene una batteria integrata che deve essere rimossa SOLO dai centri di assistenza o dai centri adibiti al riciclaggio, con riferimento alle presenti istruzioni. Creative e le società affiliate non saranno ritenute responsabili per eventuali danni derivanti dal tentativo da parte dell'utente finale di rimuovere e/o manomettere la batteria o parti del prodotto.

ATTENZIONE:

"Prima di rimuovere la batteria, accertarsi che il prodotto sia scollegato dal cavo di carica"

"Coprire uno dei terminali della batteria con nastro isolante per evitare cortocircuiti" (non applicabile alle batterie con connettore)

Istruzioni di rimozione della batteria:

1. Rimuovere la protezione in gomma dal lato destro dell'altoparlante.
2. Svitare le viti del coperchio rosso.
3. Rimuovere il coperchio rosso.
4. Far scorrere la griglia metallica estraendola dal lato destro.
5. Svitare le viti del coperchio frontale.
6. Rimuovere il coperchio frontale.
7. Estrarre la presa del cavo della batteria dal complesso di schede a circuiti stampati principale. Svitare le viti e rimuovere il complesso di schede a circuiti stampati principale. Rimuovere quindi la batteria.

[DE] Sicherer Ausbau des integrierten Akkus

Dieses Produkt enthält einen integrierten Akku, der NUR durch Service-Center oder Recycling-Stellen unter Befolgung der hier enthaltenen Anleitung entfernt werden darf. Creative und dessen Partner haften nicht für eventuelle Schäden, die aus dem Versuch entstehen, den Akku oder beliebige andere Teile des Produkts auszubauen oder zu manipulieren.

VORSICHT:

"Stellen Sie sicher, dass das Produkt vom Ladekabel getrennt wurde, bevor Sie den Akku ausbauen"

"Überkleben Sie einen der Akku-Pole mit Isolierband, um einen Kurzschluss zu verhindern" - gilt nicht für Akkus mit Stecker

Ausbauanleitung des Akkus:

1. Entfernen Sie die GummifüÙe an der rechten Seite des Lautsprechers.
2. Lösen Sie die Schrauben an der roten Abdeckung.
3. Entfernen Sie die rote Abdeckung.
4. Schieben Sie das Metallgitter von der rechten Seite aus heraus.
5. Lösen Sie die Schrauben an der vorderen Abdeckung.
6. Entfernen Sie die vordere Abdeckung.
7. Ziehen Sie den Akkukabel-Stecker von der Hauptplatine ab. Lösen Sie die Schrauben und entfernen Sie die Hauptplatine. Entfernen Sie anschließend den Akku.

[ES] Extracción de seguridad de la batería integrada

Este producto contiene una batería integrada que SOLAMENTE debe ser extraída por centros de servicio o instalaciones de reciclaje con referencia a estas instrucciones. Creative y sus filiales no serán consideradas responsables por cualquier daño resultante del intento de extracción o alteración de la batería o de cualquier otra pieza del producto por parte del usuario final.

PRECAUCIÓN:

"Asegúrese de que el cable de carga del producto está desconectado antes de la extracción de la batería"

"Cubra uno de los terminales de la batería con cinta aislante para prevenir cortocircuitos" - no aplicable a baterías con conectores

Instrucciones para la extracción de la batería:

1. Quite la almohadilla de goma del lado derecho del altavoz.
2. Afloje los tornillos de la cubierta roja.
3. Retire la cubierta roja.
4. Extraiga la rejilla metálica deslizándola desde el lado derecho.
5. Afloje los tornillos de la cubierta delantera.
6. Retire la cubierta delantera.
7. Extraiga la toma del cable de la batería de la PCBA principal. Afloje los tornillos y extraiga la PCBA principal. A continuación, extraiga la batería.

[NL] Veilige verwijdering van ingebouwde batterij

Dit product bevat een ingebouwde batterij en mag alleen worden verwijderd door servicecentra of recyclingfaciliteiten met verwijzing naar de hieronder beschreven aanwijzingen. Creatieve en haar gelieerde bedrijven zijn niet aansprakelijk voor schade die veroorzaakt wordt door het verwijderen en/of modificeren van de batterij of een deel van het product door een eindgebruiker.

LET OP:

"Zorg ervoor dat het apparaat wordt losgekoppeld van de oplaadkabel voordat u de batterij verwijdert"

"Één van de terminals van de batterij afplakken met isolatietape om kortsluiting te voorkomen" - niet van toepassing op batterij met een connector

Aanwijzingen voor het verwijderen van de batterij:

1. Verwijder de rubberen materiaal van de rechterzijde van de luidspreker.
2. Draai de schroeven op de rode cover los.
3. Verwijder de rode cover.
4. Schuif de metalen grill uit de rechterzijde.
5. Draai de schroeven op de voorste cover los.
6. Verwijder de voorste cover.

7. Trek de batterijkabeluitvoer van het moederbord. Draai de schroeven los en verwijder het moederbord. Verwijder vervolgens de batterij.

[PT] Remoção em segurança da bateria integrada

Este produto contém uma bateria integrada que APENAS deve ser removida pelos centros de serviço ou instalações de reciclagem com referência às instruções deste documento. A Creative e as suas afiliadas não podem ser consideradas responsáveis por quaisquer danos resultantes da tentativa para remover e/ou adulterar a bateria ou qualquer peça do produto por parte de um utilizador final.

CUIDADO:

"Certifique-se de que o cabo de carregamento do produto está desligado antes de remover a bateria"
"Tape um dos terminais da bateria com fita isoladora para prevenir um curto-circuito" - não aplicável a baterias com conector

Instruções para remoção da bateria:

1. Retire a proteção de borracha do lado direito do altifalante.
2. Desaperte os parafusos na cobertura vermelha.
3. Retire a cobertura vermelha.
4. Deslize a grelha metálica pelo lado direito.
5. Desaperte os parafusos na tampa frontal.
6. Retire a cobertura frontal.
7. Puxe a tomada do cabo da bateria para fora do PCBA principal. Desaperte os parafusos e retire o PCBA principal. Depois, retire a bateria.

[DK] Sikker fjernelse af indbygget batteri

Dette produkt indeholder et indbygget batteri, som KUN må fjernes af servicecentre eller genbrugsanlæg, i overensstemmelse med de medfølgende vejledninger. Creative og dets associerede selskaber, kan ikke holdes ansvarlige for skader forårsaget af forsøg på at fjerne og/eller ændre batteriet, eller nogle andre dele af produktet, på vegne af en slutbruger.

FORSIGTIG:

"Kontroller at produktet er afbrudt fra opladerkablet, før batteriet fjernes"
"Tildæk en af batteripolerne med isoleringstape for at forhindre en kortslutning" - ikke gældende for batteri med konnektor

Vejledning til fjernelse af batteri:

1. Fjern gummipuden fra højre side af højttaleren.
2. Løsn skruerne på det røde dæksel.
3. Fjern det røde dæksel.
4. Skub metalgitteret ud fra højre side.
5. Løsn skruerne på frontdækslet.
6. Fjern frontdækslet.
7. Træk batterikabeludgangen ud fra hovedprintpladen. Løsn skruerne og fjern hovedprintpladen. Fjern derefter batteriet.

[SV] Säker borttagning av inbyggt batteri

Denna produkt innehåller ett integrerat batteri som bör tas bort ENDAST av personal på servicecenter eller återvinningsanläggningar vilka tar hänsyn till instruktionerna här nedan. Creative och dess

dotterbolag ansvarar inte för skador som uppkommit på grund av att slutanvändaren har försökt att ta ur och/eller manipulera batteriet eller någon annan produkt del.

VARNING!

"Säkerställ att produkten inte är ansluten med nätkabeln innan du tar ur batteriet."

"Täck en av batteriterminalerna med isoleringstejp för att förhindra kortslutning" – gäller ej för batterier med anslutning

Instruktioner för borttagning av batteri:

1. Demontera gummilappen från högtalarens högersida.
2. Skruva loss skruvarna på det röda locket.
3. Demontera det röda locket.
4. Skjut metallgallret ut åt höger.
5. Skruva loss skruvarna på det främre locket.
6. Demontera det främre locket.
7. Dra ur batterikabeln ur huvud-PCBA. Skruva loss skruvarna och demontera huvud-PCBA:n. Därefter demonterar du batteriet.

[NO] Sikker fjerning av innebygd batteri

Dette produktet har et integrert batteri som KUN skal fjernes av servicesentre eller gjenbruksanlegg med referanse til instruksjonene heri. Creative og deres samarbeidspartnere vil ikke være ansvarlige for noen skader oppstått ut fra forsøk på å fjerne og/eller tukle med batteriet eller noen del av produktet av en sluttbruker.

FORSIKTIG:

«Påse at produktet er koblet fra ladekabelen før batteriet fjernes»

«Dekk til en av batteriterminalene med isolasjonstape for å forhindre kortslutning» - gjelder ikke for batteri med kobling

Instruksjoner for fjerning av batteri:

1. Ta løs gummimatten fra høyttalerens høyre side.
2. Løsne skruene på det røde dekslet.
3. Ta løs det røde dekslet.
4. Dra metallristen ut fra høyre side.
5. Løsne skruene på dekslet framme.
6. Ta løs dekslet framme.
7. Dra batteriledningsuttaket ut av hoved-PCBA. Løsne skruene og ta løs hoved-PCBA. Ta så ut batteriet.

[FI] Sisäänrakennetun akun turvallinen poistaminen

Tässä tuotteessa on sisäänrakennettu akku, jonka saavat poistaa VAIN huoltokeskukset tai kierrätyskeskukset tässä mainittuja ohjeita noudattaen. Creative ja sen tytäryritykset eivät ole vastuussa mistään vahingoista, jotka johtuvat siitä, että loppukäyttäjä yrittää poistaa ja/tai peukaloita akkua tai muuta tuotteen osaa.

VAROITUS:

"Varmista, että tuote on irrotettu latausjohdosta ennen akun poistamista."

"Peitä yksi akun terminaleista eristysteipillä, jotta estetään oikosulku" - ei koske akkua, jossa on liitin

Akun irrotusohjeet:

1. Poista kumisuojus kaiuttimen oikealta puolelta.
2. Irrota punaisen suojuksen kaksi ruuvia.
3. Irrota punainen suojus.
4. Liu'uta metallisäleikkö ulos oikealta puolelta.
5. Irrota etusuojuksen ruuvit.
6. Irrota etusuojus.
7. Vedä akkukaapelin liitin ulos pääpiirilevystä. Irrota pääpiirilevyn ruuvit ja poista se. Irrota sitten akku.

[EL] Ασφαλής αφαίρεση της ενσωματωμένης μπαταρίας

Αυτό το προϊόν περιέχει ενσωματωμένη μπαταρία η οποία πρέπει να αφαιρείται ΜΟΝΟ από εξειδικευμένα κέντρα ή εγκαταστάσεις ανακύκλωσης με καθοδήγηση από τις παρούσες οδηγίες. Η Creative και οι συνεργάτες της δε φέρουν καμία ευθύνη για φθορές λόγω απόπειρας αφαίρεσης της μπαταρίας ή άλλου εξαρτήματος του προϊόντος από τον τελικό χρήστη.

ΠΡΟΣΟΧΗ:

"Σιγουρευτείτε ότι έχετε αφαιρέσει το καλώδιο φόρτισης προτού αφαιρέσετε την μπαταρία"
"Καλύψτε ένα από τα τερματικά της μπαταρίας με μονωτική ταινία ώστε να αποφύγετε τυχόν βραχυκύκλωμα" - δεν ισχύει για μπαταρίες με βύσμα

Οδηγίες αφαίρεσης της μπαταρίας:

1. Αφαιρέστε το πλαστικό κάλυμμα από το δεξί ακουστικό.
2. Ξεβιδώστε τις βίδες από το κόκκινο κάλυμμα.
3. Αφαιρέστε το κόκκινο κάλυμμα.
4. Σύρετε το μεταλλικό κλείστρο προς τα δεξιά.
5. Ξεβιδώστε τις βίδες από το μπροστινό κάλυμμα.
6. Αφαιρέστε το μπροστινό κάλυμμα.
7. Τραβήξτε το καλώδιο μπαταρίας από το κεντρικό PCBA. Ξεβιδώστε τις μπαταρίες και αφαιρέστε το κεντρικό PCBA. Στη συνέχεια, αφαιρέστε την μπαταρία.

[PL] Bezpieczne usuwanie wbudowanej baterii

Ten produkt zawiera zintegrowaną baterię, którą należy usuwać TYLKO w punktach serwisowych lub zakładach recyklingowych oraz zgodnie z zamieszczonymi instrukcjami. Firma Creative i jej partnerzy nie ponoszą odpowiedzialności za jakiegokolwiek szkody wynikające z podejmowania prób wyjęcia baterii i/lub manipulowania baterią lub jakiegokolwiek częścią produktu przez użytkownika końcowego.

UWAGA:

"Przed przystąpieniem do wyjęcia baterii upewnić się, że produkt jest odłączony od kabla ładującego."
"Osłonić jeden ze styków baterii taśmą izolacyjną, aby zapobiec wystąpieniu zwarcia." - nie dotyczy baterii wyposażonych w złącze

Instrukcja wyjmowania baterii:

1. Zdejmij gumową nakładkę z prawej strony głośnika.
2. Odkręć wkręty na czerwonej pokrywie.
3. Zdejmij czerwoną pokrywę.
4. Przesuń metalową kratkę z prawej strony.
5. Odkręć wkręty na przedniej pokrywie.
6. Zdejmij przednią pokrywę.

7. Wyciągnij gniazdo przewodu akumulatora z płyty głównej. Odkręć wkręty i zdejmij płytę główną. Następnie wyjmij akumulator.

[CZ] Bezpečné vyjmutí zabudované baterie

Produkt obsahuje integrovanou baterii, kterou mohou vyjímat POUZE pracovníci servisních center nebo recyklačních zařízení dle zde uvedených pokynů. Společnost Creative a její přidružené společnosti nebudou odpovídat za žádné škody vyvstávající z nedovolené manipulace nebo pokusu o vyjmutí baterie či jakékoli součásti produktu koncovým uživatelem.

UPOZORNĚNÍ:

„Než se pokusíte vyjmout baterii, ujistěte se, že je produkt odpojen od napájecího kabelu.“

„Jeden z pólů baterie zakryjte izolační páskou, čímž zabráníte zkratování“ – tento pokyn se netýká baterie s konektorem

Pokyny k vyjmutí baterie:

1. Sejměte gumovou podložku z pravé strany reproduktoru.
2. Odmontujte šrouby na červeném krytu.
3. Sejměte červený kryt.
4. Vysuňte kovovou mřížku z pravé strany.
5. Odmontujte šroubky na předním krytu.
6. Sejměte přední kryt.
7. Sejměte kabelový výstup baterie z hlavní PCBA. Odmontujte šroubky a vyjměte hlavní PCBA. Potom vyjměte baterii.

[SK] Bezpečné vyberanie vstavanej batérie

Tento výrobok obsahuje integrovanú batériu, ktorú môžu vybrať IBA v servisných strediskách alebo v organizáciách určených na zber a recykláciu odpadu v súlade s pokynmi v tomto dokumente. Spoločnosť Creative a jej pobočky nenesú zodpovednosť za žiadnu škodu, ak koncový používateľ vyberie batériu alebo ak manipuluje s touto batériou alebo s ktorýmkoľvek z dielov v tomto výrobku.

UPOZORNENIE:

„Pred vyberaním batérie sa uistite, že nabíjací kábel je odpojený od výrobku.“

„Na jeden kontakt batérie založte izolačnú pásku, aby sa zabránilo skratu“ - neplatí pre batériu s konektorom

Pokyny týkajúce sa vyberania batérie:

1. Z pravej strany reproduktora snímte gumený blok.
2. Uvoľnite skrutky na červenom kryte.
3. Odstráňte červený kryt.
4. Z pravej strany vysuňte kovovú mriežku.
5. Uvoľnite skrutky na prednom kryte.
6. Odstráňte predný kryt.
7. Zo zostavy dosky plošných spojov vyťahnite vývod kábla batérie. Uvoľnite skrutky a demontujte hlavnú zostavu dosky plošných spojov. Potom vyberte batériu.

[HU] Az elem biztonságos eltávolítása

Ez a termék elemet is tartalmaz, amelyet azonban CSAK szervizekben vagy újrahasznosító telepeken távolíthatnak el a készülékből az erre vonatkozó utasítások betartása mellett. A Creative vállalat és

annak leányvállalatai nem tehetősek felelőssé semminemű olyan kárért, amelyet egy végfelhasználó okozott az elem vagy a termék bármely részének eltávolításával és/vagy megrongálásával.

FIGYELEM!

„Az elem eltávolítása előtt győződjön meg arról, hogy a termék le van-e csatlakoztatva a töltőkábelről.”
„Rövidzárlat megakadályozása érdekében ragassza le az elem egyik pólusát szigetelőszalaggal” – erre nincs szükség csatlakozóval ellátott elemek esetén

Az elem eltávolításának lépései:

1. Távolítsa el a gumipárnát a hangszóró jobb oldaláról.
2. Távolítsa el a piros burkolaton található csavarokat.
3. Távolítsa el a piros burkolatot.
4. Csúsztassa ki a fémrácsot a jobb oldalról.
5. Távolítsa el az elülső burkolaton található csavarokat.
6. Távolítsa el az elülső burkolatot.
7. Távolítsa el az elemkábel-kimenetet a fő nyomtatott áramköri lap szerelvényéről. Oldja a csavarokat, és távolítsa el a fő nyomtatott áramköri lap szerelvényt. Ezt követően távolítsa el az elemet.

[LT] Saugus integruotos baterijos išėmimas

Šiame produkte yra integruota baterija, kurią galima išimti TIK aptarnavimo centre arba perdirbimo įstaigoje laikantis čia pateiktų instrukcijų. „Creative“ ir jos padaliniai neprisiima atsakomybės už žalą, patirtą galutiniam vartotojui bandant išimti ir / arba ardyti bateriją ar bet kurią produkto dalį.

PERSPĖJIMAS:

„Prieš išimdami bateriją įsitikinkite, kad produktas yra atjungtas nuo elektros laidų“
„Uždenkite vieną baterijos gnybtą lipnia juostele, kad neįvyktų trumpas jungimasis“ – netaikoma baterijoms su jungikliu

Baterijos išėmimo instrukcija:

1. Nuimkite guminę apsaugą nuo dešiniojo garsiakalbio šono.
2. Atsukite varžtus, esančius ant raudono dangtelio.
3. Nuimkite raudoną dangtelį.
4. Išstumkite metalines groteles iš dešniosios pusės.
5. Atsukite varžtus, esančius ant priekinio dangtelio.
6. Nuimkite priekinį dangtelį.
7. Ištraukite maitinimo elemento laidą iš pagrindinės PCBA plokštės. Atsukite varžtus ir nuimkite pagrindinę PCBA plokštę. Tada išimkite maitinimo elementą.

[RU] Безопасное извлечение встроенной аккумуляторной батареи

Настоящий продукт содержит встроенную аккумуляторную батарею, которую разрешается извлечь ТОЛЬКО в сервисном центре или на объекте по утилизации с соблюдением приведенных в настоящем документе инструкций. Компания Creative и ее дочерние компании не несут ответственности за любые повреждения, нанесенные в результате попытки извлечения и/или нарушения целостности аккумуляторной батареи или любой части изделия конечным пользователем.

ВНИМАНИЕ:

«Перед извлечением аккумуляторной батареи убедитесь, что изделие отсоединено от зарядного кабеля»

«Накройте одну из клемм аккумуляторной батареи изоляционной лентой, чтобы предотвратить короткое замыкание» - не применимо для аккумуляторной батареи с соединителем

Инструкция по извлечению аккумуляторной батареи:

1. Снимите резиновую вставку с правой стороны динамика.
2. Открутите винты на красной крышке.
3. Снимите красную крышку.
4. Сдвиньте металлическую решетку с правой стороны.
5. Открутите винты на передней крышке.
6. Снимите переднюю крышку.
7. Отключите кабель аккумулятора от главной платы. Открутите винты и снимите главную плату. Затем извлеките аккумулятор.

License and Copyright

Information in this document is subject to change without notice and does not represent a commitment on the part of Creative Technology Ltd. No part of this manual may be reproduced or transmitted in any form or by any means, electronic or mechanical, including photocopying and recording, for any purpose without the written permission of Creative Technology Ltd.

Copyright © 2015 Creative Technology Ltd. All rights reserved. Creative, the Creative logo, Sound Blaster, the Sound Blaster logo, SBX Pro Studio and the SBX logo are trademarks or registered trademarks of Creative Technology Ltd. in the United States and/or other countries. iPhone is a trademark of Apple Inc., registered in the U.S. and other countries. Android is a trademark of Google Inc. Windows is a registered trademark of Microsoft Corporation in the United States and other countries. The *Bluetooth*[®] word mark and logos are registered trademarks owned by Bluetooth SIG, Inc. and any use of such marks by Creative Technology Ltd is under license. Other trademarks and trade names are those of their respective owners. All specifications are subject to change without prior notice. Use of this product is subject to a limited hardware warranty. Actual contents may differ slightly from those pictured. The software included in this packaging may not be used separately from the hardware. Before using the software, you must agree to be bound by the terms and conditions of the end user license agreement.

Version 1.1

September 2015