

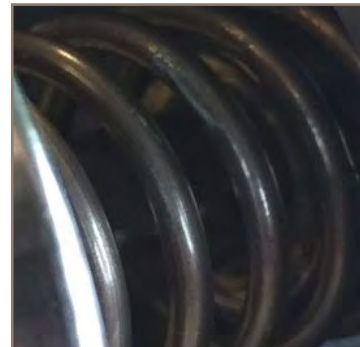

Maintenance & Installation

Bladder Accumulators
Electronic Catalog: HY10-1632-M2/US



ENGINEERING YOUR SUCCESS.



Machesney Park, Illinois
10711 N. Second Street, Machesney Park, IL 61115



Santa Fe Springs, California
14087 Borate Street, Santa Fe Springs, CA 90670

If you have questions about the information contained in this Maintenance & Installation Guide, please contact:

Accumulator & Cooler Division - Americas
phone **815 636 4100**
parker.com/accumulator

The information specified in this guide serves to help understand how to install & maintain the product. The information given does not release the user from their own judgment and obligation of verification. The natural process of wear and aging also impacts how easily a product can be serviced.

Extra care is taken in the preparation of this literature, but Parker is not responsible for any inadvertent typographical errors or omissions. Information in this guide is only accurate as of the date of this publication. For a more current information base, please consult the Parker Accumulator & Cooler Division website at:
www.parker.com/accumulator

Offer of Sale

The items described in this document are hereby offered for sale by Parker Hannifin Corporation, its subsidiaries or its authorized distributors. This offer and its acceptance are governed by the provisions in the "Offer of Sale."

⚠ WARNING - USER RESPONSIBILITY

FAILURE OR IMPROPER SELECTION OR IMPROPER USE OF THE PRODUCTS DESCRIBED HEREIN OR RELATED ITEMS CAN CAUSE DEATH, PERSONAL INJURY AND PROPERTY DAMAGE.

This document and other information from Parker-Hannifin Corporation, its subsidiaries and authorized distributors provide product or system options for further investigation by users having technical expertise. The user, through its own analysis and testing, is solely responsible for making the final selection of the system and components and assuring that all performance, endurance, maintenance, safety and warning requirements of the application are met. The user must analyze all aspects of the application, follow applicable industry standards, and follow the information concerning the product in the current product catalog and in any other materials provided from Parker or its subsidiaries or authorized distributors. To the extent that Parker or its subsidiaries or authorized distributors provide component or system options based upon data or specifications provided by the user, the user is responsible for determining that such data and specifications are suitable and sufficient for all applications and reasonably foreseeable uses of the components or systems.

© Copyright 2016 Parker Hannifin Corporation. All rights reserved.



Contents

General Information	1
General Safety	1
Warranty	2
Operator Obligations	2
Product Description	2
Pressure Ratings	3
Labeling & Stamping	4
Main Product Label	4
ASME Shell Stamping Detail	5
CE Shell Stamping Detail	5
Canadian & Australian Label Detail	6
Canadian Stamping Detail	6
Parts Description	7
Accumulator Parts Description (Gas Side)	7
Bladder Repair Kit Part Numbers	9
Oil & Water Service	9
Chemical Service	10
Accumulator Parts Description (Oil Side)	11
Hydraulic Assembly Port Numbers	13
Transport	14
Commissioning	15
Installation of New Accumulator	15
Prepare for Commissioning	16
Pre-Charging	17
Charging & Gauging Assemblies	17
Monitoring & Maintenance	21
Assembly & Disassembly	23
Removal of Accumulator From the Hydraulic System	23
Disassembly of Bottom Repairable Accumulators	24
Clean & Inspect	26
Bladder Assembly in Bottom Repairable Accumulators	27
Disassembly of Conventional Top-Repairable Accumulators	29
Clean & Inspect	29
Bladder Assembly in Conventional Top-Repairable Accumulators	30
Hydraulic Port Assembly Installation	30
Storage	33
Bladder Accumulator Storage	33
Bladder Storage	33
Recycling & Disposal	34

General Information

This guide discusses how to safely transport, install, commission, maintain, and disassemble Parker Hannifin's BA Series Bladder Accumulators. This guide is to be read thoroughly, particularly the Safety Instructions below before maintaining or servicing the BA Series Accumulators. Keep this guide accessible for anyone who may attempt to service or maintain the accumulators described within.

Intended Use

Parker BA Series accumulators are intended to be used in hydraulic systems for the purposes of:

- Energy storage and auxiliary power
- Shock and vibration dampening & absorption
- Volume compensation due to thermal changes or loss in positive pressure
- Maintaining fail safe power to complete a safety cycle in the event of loss of pump or electric power
- Dispensing lubricants in a slow, constant rate

Bladder accumulators are pressure vessels and are held to design codes, industrial regulations and local provisions for the countries in which they are used. Since bladder accumulators are intended to be installed in a machine or system, they must conform to the Pressure Equipment Directive 2014/68/EU (formerly 97/23/EC) for use in the European Union. Additional design codes, like ASME's Boiler and Pressure Vessel Code Section VIII, Division 1, may also be required in the United States, as well as other design codes, industry regulations, and local provisions. It is important to know your country's, industry's or locality's pressure vessel requirements.

General Safety

BA Series Bladder Accumulators are designed to be inherently safe when the limiting values on the product label or name plate are followed. However, there is a risk of personal injury and equipment damage if you do not follow the safety, maintenance instructions, and the warning notices specified in this guide.

Since hydraulic accumulators are pressure vessels, the installation, commissioning, disassembly, and maintenance should be performed by professionally trained and qualified personnel.

The following safety instructions must always be followed when working with hydraulic accumulators:

- ⚠ Only use an inert gas like nitrogen for a pre-charging.** Nitrogen that is 99.99 percent by volume is strongly recommended. **Do not use oxygen or shop air**, as this may lead to a fire or explosion.
- ⚠ Modifying a bladder accumulator** (i.e. welding, brazing, machining, or the use of non-original replacement parts) **may compromise the integrity of the pressure vessel.**
- ⚠ The operating pressure of the accumulator must not exceed the maximum operating pressure and the temperature ranges must be within those indicated on the label or nameplate.**
- ⚠ The bladder-type accumulator must not be operated with group 1 hydraulic fluids** (explosive, inflammable, toxic) **or with corrosive fluids.**
- ⚠ Never loosen the gas valve while the accumulator is under pressure.**
- ⚠ Never attempt to disassemble the accumulator while it is under pressure.**
- ⚠ Always assume the accumulator is under pressure until it is confirmed that it isn't.**
- ⚠ Never add unnecessary weight or load on top of the accumulator, never use the accumulator as a structural support and never step on them.**
- ⚠ The accumulator may become very hot during normal operation.** Allow the accumulator to cool before any servicing or touching it.
- ⚠ Always wear personal protective equipment (PPE) like safety glasses and protective gloves when servicing the accumulator.**

Warranty

Parker Hannifin warrants the BA Series Bladder Accumulator shall be free from defects in material or workmanship for a period of 18 months from the date of shipment from our facility provided the instructions for installation, operation, and maintenance in this guide are followed and the operational limits set forth on the product label or nameplate are not exceeded. The warranty doesn't cover normal wear during the operation of the accumulator. If the bladder accumulator is modified in any way (i.e. welding, brazing, machining, or the use of non-original replacement parts), the warranty will be considered null and void and any certifications applied to the accumulator will be revoked. For complete terms of condition, warranty information and indemnification, refer to Parker's Offer of Sale.

Operator Obligations

Parker's BA Series Bladder Accumulators come with a black primer or nickel coating. It is the operator's responsibility to assure sufficient corrosion protection for the environment it is placed in. It is the responsibility of the buyer to make sure any individuals who install, operate, and maintain the accumulator are properly trained at regular intervals on those subjects. It is also the responsibility of the buyer to make sure users of the accumulator follow local and country safety and environmental rules and regulations.

Product Description

Bladder accumulators are suitable for storing energy under pressure, absorbing hydraulic shocks, and dampening pump pulsation and flow fluctuations. Bladder accumulators provide excellent gas and fluid separation, ensuring dependable performance, maximum efficiency, and long service life.

Pressure Ratings

Design Code Table													
Style	Size	US Design Codes				PED Design Codes			Canadian & Australian Codes				
		Non-ASME	ASME	Non-ASME & ASME Design Pressure	Appendix 22 Design Pressure	Stand. Eng. Practice (SEP)	CE	PED Design Pressure	CRN	AS 1210	CRN & AS 1210 Design Pressure		
											ASME	Append 22	
Bottom Repairable, Standard Pressure	10 Cu. In.	Y		3000 PSI		Y		330 Bar	Upon Request	Upon Request	Upon Request	Upon Request	
	Pint	Y		3000 PSI		Y		330 Bar	Upon Request	Upon Request	Upon Request	Upon Request	
	Quart	Y	R**	3000 PSI		Y		330 Bar	Upon Request	Upon Request	Upon Request	Upon Request	
	150 cu. in.	Y	R**	3000 PSI			Y	330 Bar	Upon Request	Upon Request	Upon Request	Upon Request	
	1 Gallon		P	3000 PSI	4000 PSI		P	330 Bar	P	P	3000 PSI	4000 PSI	
	2.5-15 Gallon		P	3000 PSI	3600 PSI		P	330 Bar	P	P	3000 PSI	3600 PSI	
Bottom Repairable, High Pressure	1 Gallon		P	5000 PSI	6600 PSI		P	690 Bar	Upon Request	Upon Request	Upon Request	Upon Request	
	2.5-15 Gallon*		P	5000 PSI	6600 PSI		P	690 Bar	Upon Request	Upon Request	Upon Request	Upon Request	
Top Repairable, Standard Pressure	2.5-15 Gallon		P	3000 PSI	3600 PSI		P	330 Bar	P	P	3000 PSI	3600 PSI	
Top Repairable, High Pressure	2.5-15 Gallon*		P	5000 PSI	6600 PSI		P	690 Bar	Upon Request	Upon Request	Upon Request	Upon Request	

*High Pressure not available for 11 gallon size

**ASME Designs available by requesting an "R" in the Design Code position of the Model Code (Call factory)

Design Code Key
P = ASME / Appx. 22 / PED
R = ASME / PED 10-150 Cu. In.
Y = Non ASME/ PED 10-150 Cu. In.

Temperature Ratings

- ASME / Canadian CRN / Australian AS1210 Design Temp: -65°F to 200°F (-54°C to 93°C)
- PED 2014/68/EU (formerly 97/23/EC) Design Temp: -54°C to 150°C (-65°F to 302°F)

Fluids

BA Series bladders & seals are compatible with a wide variety of fluids, such as petroleum-based oils, water-glycol, or water-based flame resistant fluids. Bladders are compatible with most industrial fluids and can be furnished with temperature ranges from -40°C to 121°C (-40°F to 250°F).

Pressure Retaining Material Specifications

All pressure retaining components have materials that are traceable per an EN 10204 Type 3.2 certificate.

Shell - high strength alloy steel, complies with both ASME SA-372 & EN 100083-3 material specifications

- Oil Service: Black water-based epoxy
- Water Service: Nickel plated inside and out
- Chemical Service: OD is black water-based epoxy, internals are epoxy coated

Ports - Oil Service: EN compliant high strength alloy steel

- Water Service: Same as oil service, but nickel plated
- Chemical Service 3000 PSI (330 bar): 304 or 316 Stainless Steel
- Chemical Service 5000 PSI (690 bar): ASME SA564 & EN 100883-3 Stainless Steel or EN 10272 Stainless Steel



**Main Product Label Detail
 (Safety & PED 2014/68/EU info)**

All BA Series Accumulators conform to ASME Boiler and Pressure Vessel Code Section VIII, Division 1 and the European Pressure Equipment Directive 2014/68/EU (formerly 97/23/EC). Many of the accumulators in the BA Series are also Australian and Canadian registered. Each of the design codes and standards require special information on the labels and stamps.

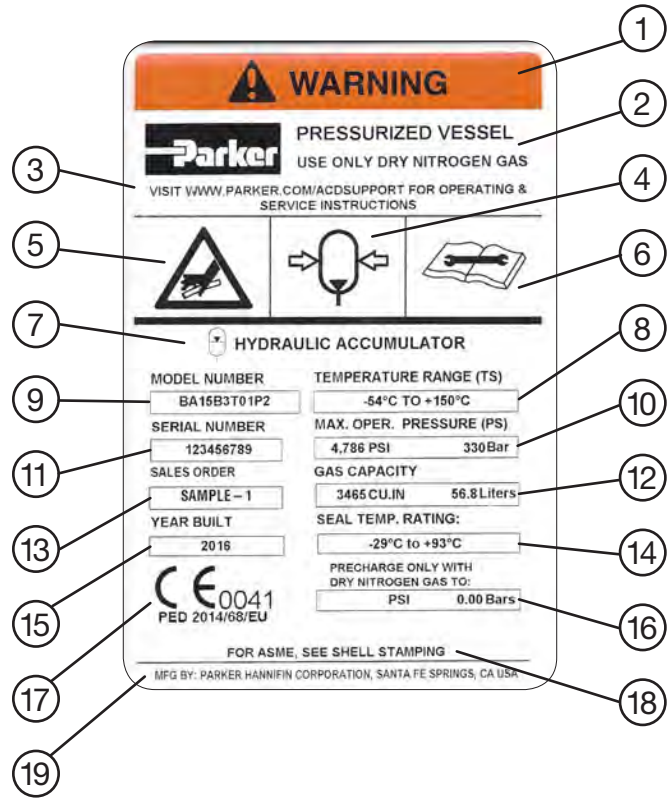

1	Warning Notice per ISO 3864-2
2	Nitrogen only warning.
3	Note to visit Parker Website for details.
4	Warning of Accumulator under pressure per ISO 7000 symbol #3317.
5	Warning noting the danger of pressurized fluid injection per ISO 9244.
6	Warning to read technical manual per ISO 7000 symbol #1659.
7	ISO 1219 schematic symbol for a bladder accumulator.
8	Temperature range external load bearing metal components will meet per PED 2014/68/EU (formerly 97/23/EC). The ASME range is stamped on the shell. They are different.
9	Parker's BA Series Model Number
10	The maximum operating pressure the accumulator will meet per PED 2014/68/EU (formerly 97/23/EC). The max. ASME operating pressure is stamped on the shell. They are different.

11	Serial number of the specific accumulator.
12	The internal gas capacity of the accumulator.
13	Parker's sales order number for the manufacturing lot. This helps customer service rapidly answer any questions pertaining to the specific accumulator.
14	Temperature range the internal seal components & bladder will continuously meet without rapid degradation.
15	The year the accumulator was manufactured.
16	The customer specified nitrogen pre-charge pressure. If no pre-charge is specified by the customer, this will be left blank. There will still be a holding charge of 29 PSig (2 bar) max inside the accumulator.
17	Parker's CE registration number per PED 2014/68/EU (formerly 97/23/EC). If the vessel pressure x volume (PS x V) ratio is less than 50, then the accumulator will be marked SEP for Sound Engineering Practice per Article 4.3. (Formerly Article 3.3 under 97/23/EC.)
18	Reminder that all ASME information is stamped on shell.
19	Parker's manufacturing address.



ASME Shell Stamping Detail

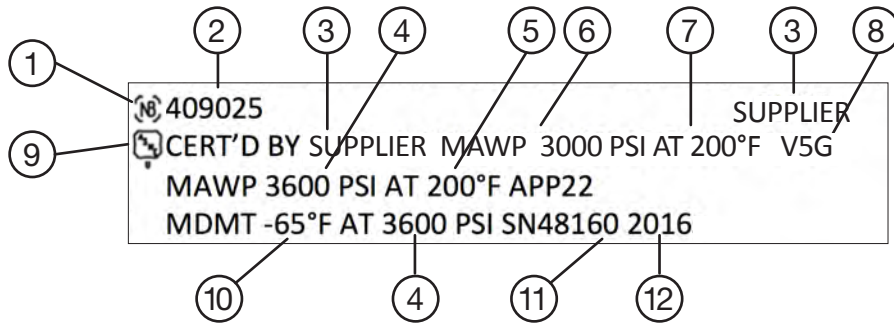

1	National Board of Boiler & Pressure Vessel Inspectors symbol
2	National Board registration number
3	Name of shell manufacturer
4	Maximum Allowable Working Pressure (MAWP) based on ASME Section VIII, Division I, Appendix 22.
5	Rated temperature for the Appendix 22 MAWP
6	Maximum Allowable Working Pressure (MAWP) based on ASME Section VIII, Division I.

7	Rated temperature for the ASME MAWP
8	Internal gas capacity or volume in gallons
9	Official ASME Division 1 U certification stamp
10	Minimum Design Metal Temperature (MDMT) based on ASME Section VIII, Division 1, Appendix 22.
11	Shell manufacturer's serial number
12	Year of manufacture

CE Shell Stamping Detail

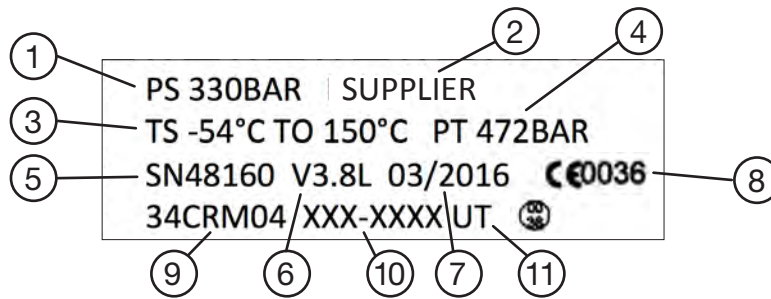

1	The maximum operating pressure (PS) the accumulator will meet per PED 2014/68/EU (formerly 97/23/EC).
2	Name of shell manufacturer
3	Temperature range (TS) external load bearing metal components will meet per PED 2014/68/EU (formerly 97/23/EC).
4	The test pressure (PT) the accumulator is tested at. (1.43 X PS)
5	Serial number of the specific accumulator.
6	Internal gas capacity or volume (V) in liters

7	Date accumulator was hydro tested.
8	Parker's CE registration number per PED 2014/68/EU (formerly 97/23/EC).
9	Accumulator shell's material per EN 100083-3
10	Shell manufacturer's batch code number.
11	Identification mark to show accumulator shell was ultrasonically tested (UT).

Canadian & Australian Label Detail

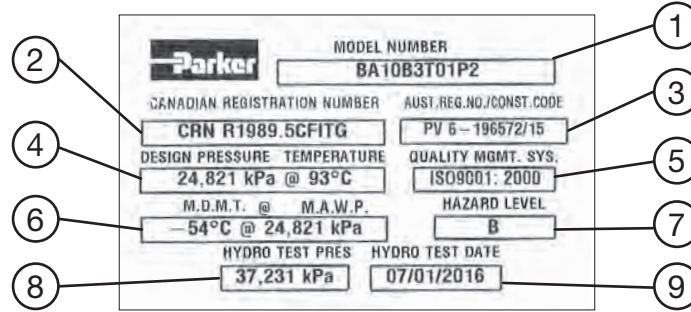

1	Parker's BA Series Model Number
2	Canadian Registration Number (CRN)
3	Australian Registration Number
4	Maximum Allowable Working Pressure (MAWP) based on ASME Section VIII, Division I, Appendix 22
5	Parker's Quality Management System as required by Australian AS1210.

6	Minimum Design Metal Temperature (MDMT) based on ASME Section VIII, Division 1, Appendix 22.
7	Hazard Levels A, B, C and D under Australian Standard AS4343.
8	Pressure the accumulator was hydro tested to. (1.5 x MAWP).
9	Date accumulator was hydrotested.

Canadian Stamping Detail

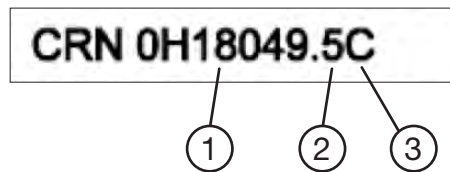

1	Base Canadian Registration Number (CRN)
2	The number of the province that the CRN was initially registered.
3	The "C" indicates that the accumulator has been registered in all provinces.

Accumulator Parts Description (Gas Side)

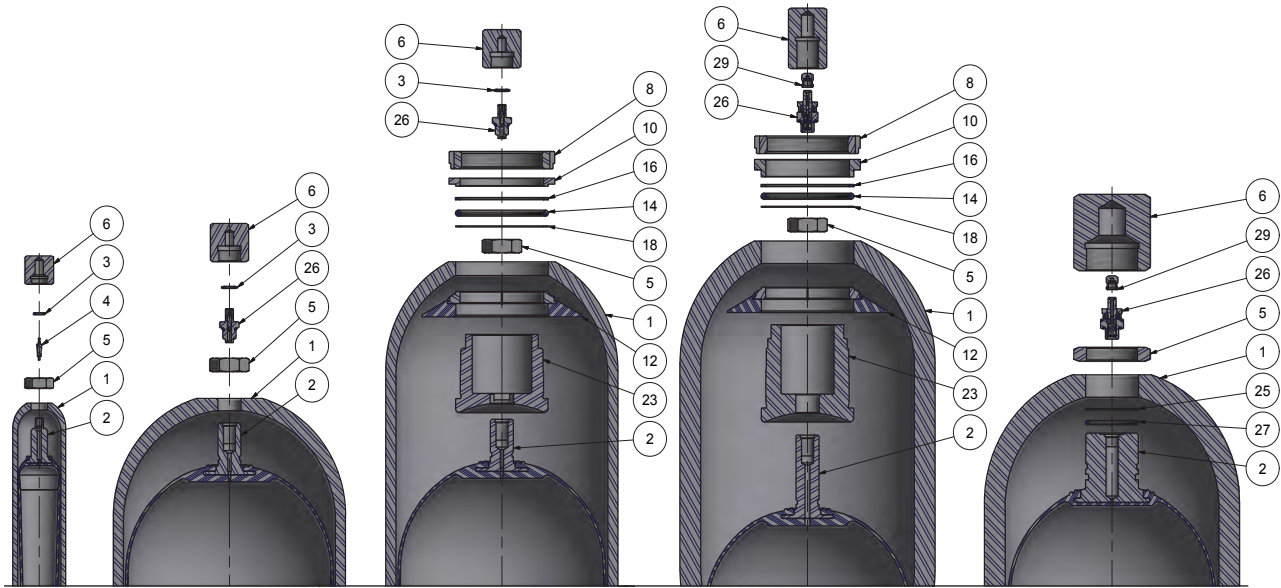

FIGURE A
 3-4 KPSI, 330 Bar
 10-150 Cu. In.
 Bottom Repairable

FIGURE B
 3-3.6 KPSI, 330 Bar
 1-15 Gallon
 Bottom Repairable

FIGURE C
 3-3.6 KPSI, 330 Bar
 2.5-15 Gallon
 Top Repairable

FIGURE D
 5-6.6 KPSI, 690 Bar
 2.5-15 Gallon
 Top Repairable

FIGURE E
 5-6.6 KPSI, 690 Bar
 1-15 Gallon
 Bottom Repairable
 (Items #25 & 27 Do Not Apply)

Bill of Material for Figures A-E	
Item No.	Description
1	Shell
2	Bladder and Stem Assembly
3	O-Ring / Sealing Washer
4	Gas Valve Core
5	Hex Jam Nut
6	Protective Cap
7	Hydraulic Port Assembly
8	Hex Jam Nut /Locking Ring
10	Hydraulic Port Spacer
12	Anti-Extrusion Ring
14	O-Ring
16	Backup Ring
18	Backup Washer (Metal)
25	Backup Ring (2" Stem Only)
26	Gas Valve
27	O-Ring (2" Stem Only)
29	Gas Valve Cap

Suggested Approximate Torque Values			
Item No.	Description	Torque (English)	Torque (Metric)
4	Gas Valve Core	3-5 In-Lb	0.34-0.56 N-M
5	Hex Jam Nut (10-150 Cu. In.)	10-15 Ft-Lb	14-20 N-M
5	Hex Jam Nut (1-15 Gallon)	100-120 Ft-Lb	136-163 N-M
6	Protective Cap	10-15 Ft-Lb	14-20 N-M
8	Locking Ring (1 Gallon)	100 Ft-Lb (Min)	136 N-M (Min)
8	Locking Ring (2.5-15 Gallon)	500 Ft-Lb (Min)	678 N-M (Min)
26	Gas Valve (All Styles)	22-28 Ft-Lb	30-38 N-M
29	Gas Valve Cap	12-24 In-Lb	1-3 N-M

Core Style Gas Valve Part Numbers for Up to 4800 PSI (330 Bar) Oil & Water Service					
Size	Bladder Bag Compound				
	Low Temp Buna	Hydrin	Butyl	EPR	Fluoroelastomer
10-150 Cu. In.	Valve Core Only (Part Number 0872690000)				
1-15 Gallon/With Cap	L07688000Q (O-RING PN 0860070005)	L07688000Q (O-RING PN 0860070005)	L07688000Q (O-RING PN 0860070005)	L07688000D (O-RING PN 0824800005)	L07688000E (O-RING PN 0824810005)

Poppet Style Gas Valve Part Numbers for Up to 5000 PSI (345 Bar) Oil, Water & Chemical Service					
Size	Bladder Bag Compound				
	Low Temp Buna	Hydrin	Butyl	EPR	Fluoroelastomer
1-15 Gallon/With Cap (Rounded Hex)	L07440T5K9 (O-RING PN 0118840003)	L07440T5K9 (O-RING PN 0118840003)	L07440T5K9 (O-RING PN 0118840003)	L07440T5K7 (O-RING PN 0479820003)	L07440T5K5 (O-RING PN 0100240003)

High Pressure Gas Valve Part Number for Up to 10,000 PSI (690 Bar) Oil, Water & Chemical Service	
Size	Bladder Bag Compound
1-15 Gallon/With Cap (Rounded Hex)	L07712T5K1-316 (O-RING PN 0477380003)



Bladder Repair Kit Part Numbers (Oil & Water Service)

3,000 PSI, 330 Bar (PED) Bottom Repairable (Per Figure A)					
Size	Buna	Hydrin	Butyl	EPR	Fluoroelastomer
10 Cu. In.	702900	702902	702903	702904	702906
1 Pint	702914	702916	702917	702918	702920
1 Quart	702928	702930	702931	702932	702934
150 Cu. In.	E702942	E702944	E702945	E702946	E702948
Kit Includes: (2) Bladder And Stem Assembly, (3) Sealing Washer, (4) Valve Core					

3,000 PSI, 330 Bar (PED) Bottom Repairable (Per Figure B)					
Size	Buna	Hydrin	Butyl	EPR	Fluoroelastomer
1 Gallon	E702956	E702958	E702959	E702960	E702962
Kit Includes: (2) Bladder And Stem Assembly, (3) Sealing Washer, (26) Gas Valve					

3,000 PSI (ASME), 330 Bar (PED) Bottom and Top Repairable (Per Figures B & C)					
Size	Buna	Hydrin	Butyl	EPR	Fluoroelastomer
2.5 Gallon	E702970	E702972	E702973	E702974	E702976
5 Gallon	E702984	E702986	E702987	E702988	E702990
10 Gallon	E702998	E703000	E703001	E703002	E703004
11 Gallon	E703012	E703014	E703015	E703016	E703018
15 Gallon	E703026	E703028	E703029	E703030	E703032
Kit Includes: (2) Bladder And Stem Assembly, (3) Sealing Washer, (14) O-Ring, (16) Backup Ring, (18) Backup Washer – Metal, (26) Gas Valve					

5,000 PSI (ASME), 690 Bar (PED) Top Repairable (Per Figure D)					
Size	Buna	Hydrin	Butyl	EPR	Fluoroelastomer
2.5 Gallon	E0870445025	E0870485025	E0870455025	E0870475025	E0870465025
5 Gallon	E0870445050	E0870485050	E0870455050	E0870475050	E0870465050
10 Gallon	E0870445100	E0870485100	E0870455100	E0870475100	E0870465100
15 Gallon	E0870445150	E0870485150	E0870455150	E0870475150	E0870465150
Kit Includes: (2) Bladder And Stem Assembly, (14) O-Ring, (16) Backup Ring, (18) Backup Washer – Metal, (26) Gas Valve, (29) Gas Valve Cap					

5,000 PSI (ASME), 690 Bar (PED), 7/8" Stem Bottom Repairable (Per Figure E)					
Size	Buna	Hydrin	Butyl	EPR	Fluoroelastomer
1 Gallon	E8706135010	E8706175010	E8706145010	E8706165010	E8706155010
Kit Includes: (2) Bladder and Stem Assembly, (26) Gas Valve, (29) Gas Valve Cap					

5,000 PSI (ASME), 690 Bar (PED), 2" Stem Bottom Repairable (Per Figure E)					
Size	Buna	Hydrin	Butyl	EPR	Fluoroelastomer
2.5 Gallon	E706000	E706002	E706003	E706004	E706006
5 Gallon	E706010	E706012	E706013	E706014	E706016
10 Gallon	E706020	E706022	E706023	E706024	E706026
15 Gallon	E706030	E706032	E706033	E706034	E706036
Kit Includes: (2) Bladder and Stem Assembly, (25) Backup Ring - 2" Stem, (26) Gas Valve, (27) O-Ring – 2" Stem, (29) Gas Valve Cap					

For Complete Rebuild Kits: Add an "R" in Front of the "H", "BH" or "TH"
 Add a "-R" suffix for oil service or a "-RW" for water service to the above part numbers.
 This kit includes all of the components in the above kits, plus the following: (5) bladder stem jam nuts, (6) protective caps and (12) anti-extrusion rings.

For 1 Quart BA Assemblies Prior to July 2016
 1 Quart Bladder Repair Kits were based on a smaller opening in the accumulator shell.
 Therefore, please add an "A1" to the end of the part number. Example: 702928-RA1 or 702928-RWA1.



Bladder Repair Kit Part Numbers (Chemical Service)

3,000 PSI (ASME), 330 Bar (PED) Bottom Repairable (Per Figure B)					
Size	Buna	Hydrin	Butyl	EPR	Fluoroelastomer
1 Gallon	E702956-H	E702958-H	E702959-H	E702960-H	E702962-H
2.5 Gallon	E702970-BH	E702972-BH	E702973-BH	E702974-BH	E702976-BH
5 Gallon	E702984-BH	E702986-BH	E702987-BH	E702988-BH	E702990-BH
10 Gallon	E702998-BH	E703000-BH	E703001-BH	E703002-BH	E703004-BH
11 Gallon	E703012-BH	E703014-BH	E703015-BH	E703016-BH	E703018-BH
15 Gallon	E703026-BH	E703028-BH	E703029-BH	E703030-BH	E703032-BH
Kit Includes: (2) Bladder and Stem Assembly, (3) Sealing Washer, (26) Gas Valve					

3,000 PSI (ASME), 330 Bar (PED) Top Repairable (Per Figure C)					
Size	Buna	Hydrin	Butyl	EPR	Fluoroelastomer
2.5 Gallon	E702970-TH	E702972-TH	E702973-TH	E702974-TH	E702976-TH
5 Gallon	E702984-TH	E702986-TH	E702987-TH	E702988-TH	E702990-TH
10 Gallon	E702998-TH	E703000-TH	E703001-TH	E703002-TH	E703004-TH
11 Gallon	E703012-TH	E703014-TH	E703015-TH	E703016-TH	E703018-TH
15 Gallon	E703026-TH	E703028-TH	E703029-TH	E703030-TH	E703032-TH
Kit Includes: (2) Bladder and Stem Assembly, (3) Sealing Washer, (14) O-Ring, (16) Backup Ring, (18) Backup Washer - Metal, (26) Gas Valve					

5,000 PSI (ASME), 690 Bar (PED) Top Repairable (Per Figure D)					
Size	Buna	Hydrin	Butyl	EPR	Fluoroelastomer
2.5 Gallon	E0870445025-H	E0870485025-H	E0870455025-H	E0870475025-H	E0870465025-H
5 Gallon	E0870445050-H	E0870485050-H	E0870455050-H	E0870475050-H	E0870465050-H
10 Gallon	E0870445100-H	E0870485100-H	E0870455100-H	E0870475100-H	E0870465100-H
15 Gallon	E0870445150-H	E0870485150-H	E0870455150-H	E0870475150-H	E0870465150-H
Kit Includes: (2) Bladder and Stem Assembly, (14) O-Ring, (16) Backup Ring, (18) Backup Washer - Metal, (26) Gas Valve, (29) Gas Valve Cap					

5,000 PSI (ASME), 690 Bar (PED), 7/8" Stem Bottom Repairable (Per Figure E)					
Size	Buna	Hydrin	Butyl	EPR	Fluoroelastomer
1 Gallon	E8706135010-H	E8706175010-H	E8706145010-H	E8706165010-H	E8706155010-H
Kit Includes: (2) Bladder and Stem Assembly, (26) Gas Valve, (29) Gas Valve Cap					

5,000 PSI (ASME), 690 Bar (PED), 2" Stem Bottom Repairable (Per Figure E)					
Size	Buna	Hydrin	Butyl	EPR	Fluoroelastomer
2.5 Gallon	E706000-H	E706002-H	E706003-H	E706004-H	E706006-H
5 Gallon	E706010-H	E706012-H	E706013-H	E706014-H	E706016-H
10 Gallon	E706020-H	E706022-H	E706023-H	E706024-H	E706026-H
15 Gallon	E706030-H	E706032-H	E706033-H	E706034-H	E706036-H
Kit Includes: (2) Bladder and Stem Assembly, (25) Backup Ring - 2" Stem, (26) Gas Valve, (27) O-Ring - 2" Stem, (29) Gas Valve Cap					

For Complete Rebuild Kits: Add an "R" in front of the "H", "BH", or "TH"
 For chemical service to the above part numbers. (Example: "RBH" for bottom repairable bladder rebuild kit for chemical service.)
 This kit includes all of the components in the above kits, plus the following: (5) bladder stem jam nut, (6) protective cap, and (12) anti-extrusion ring.



Accumulator Parts Description (Oil Side)

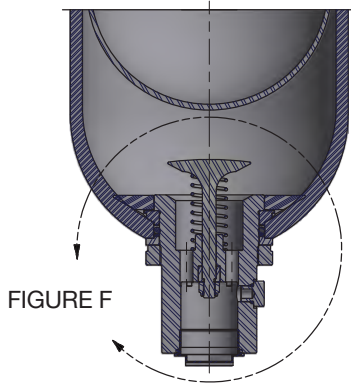
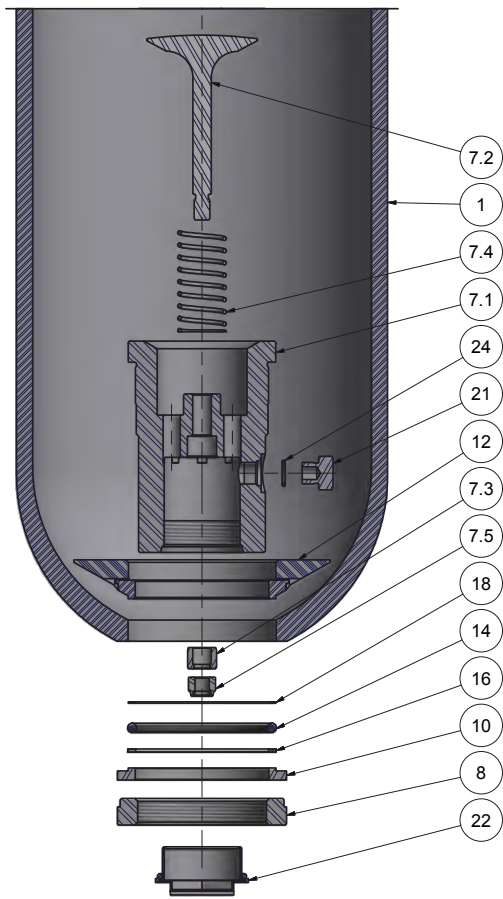

FIGURE F

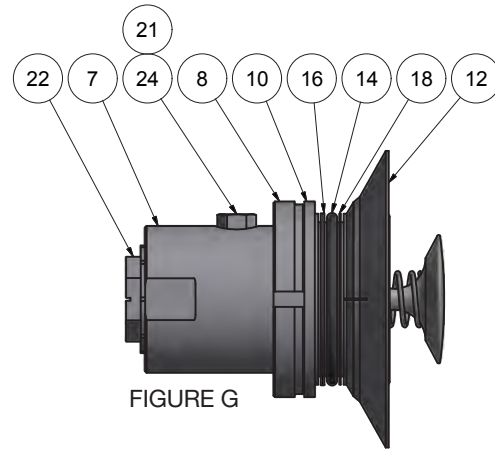

FIGURE G

Hydraulic Port Kit	
Item No.	Description
7	Hydraulic Port Assembly
8	Hex Jam Nut /Locking Ring
10	Hydraulic Port Spacer
12	Anti-Extrusion Ring
14	O-Ring
16	Backup Ring
18	Backup Washer (Metal)
21	Bleed Plug
22	Port Protector Plug
24	O-Ring

Suggested Approximate Torque Values			
Item No.	Description	Torque (English)	Torque (Metric)
7.5	Nylon Insert Locknut	6-7 Ft-Lb	8-9 N-M
8	Locking Ring (1 Gallon)	100 Ft-Lb (Min)	136 N-M (Min)
8	Locking Ring (2.5-15 Gallon)	500 Ft-Lb (Min)	678 N-M (Min)
21	Bleeder Plug	10 Ft-Lb (Min)	14 N-M
22	Port Protector Plug	12-24 In-Lb	1-3 N-M

Hydraulic Port Assembly	
Item No.	Description
7.1	Hydraulic Port Body
7.2	Poppet
7.3	Bushing
7.4	Compression Spring
7.5	Nylon Insert Locknut

10-150 Cubic-Inch. Don't Include 16, 21, & 24
 All Flange Ports. Don't Include 21 & 24



Accumulator Parts Description (Oil Side)

3,000 PSI (Non-ASME or ASME), 330 Bar (PED) Hydraulic Port Kit Part Numbers (*Oil or Water Service)						
Size	Port Style	Bladder Bag Compound				
		Buna	Hydrin	Butyl	EPR	Fluoroelastomer
10 Cu. In.	3/4" NPTF MALE	*01	L076749*01	L076743*01	L076747*01	L076745*01
	#8 SAE	L076741*02	L076749*02	L076743*02	L076747*02	L076745*02
1 Pint	3/4" NPTF	L075031*01	L075039*01	L075033*01	L075037*01	L075035*01
	#12 SAE	L075031*02	L075039*02	L075033*02	L075037*02	L075035*02
1 Qt/150 Cu. In.	1" NPTF	E074151*01	E074159*01	E074153*01	E074157*01	E074155*01
	#16 SAE	E074151*02	E074159*02	E074153*02	E074157*02	E074155*02
1 Gallon	1 1/4" NPTF	E074161*01	E074169*01	E074163*01	E074167*01	E074165*01
	#20 SAE	E074161*02	E074169*02	E074163*02	E074167*02	E074165*02
	1 1/4" Code 62 Flange	E077141*03	E077149*03	E077143*03	E077147*03	E077145*03
2.5-15 Gallon	2" NPTF	E074171*01	E074179*01	E074173*01	E074177*01	E074175*01
	#24 SAE	E074171*02	E074179*02	E074173*02	E074177*02	E074175*02
	1 1/2" Code 62 Flange	E077131*03	E077139*03	E077133*03	E077137*03	E077135*03
	1 1/4" NPTF	E074171*04	E074179*04	E074173*04	E074177*04	E074175*04

* = "O" (Standard Oil Service) * = "W" (Water Service)

3,000 PSI (Non-ASME Or ASME), 330 Bar (PED) Hydraulic Port Kit Part Numbers (Chemical Service)						
Size	Port Style	Bladder Bag Compound				
		Buna	Hydrin	Butyl	EPR	Fluoroelastomer
1 Gallon	1 1/4" NPTF	E074161001-H	E074169001-H	E074163001-H	E074167001-H	E074165001-H
	#20 SAE	E074161002-H	E074169002-H	E074163002-H	E074167002-H	E074165002-H
	1 1/4" Code 62 Flange	E077141003-H	E077149003-H	E077143003-H	E077147003-H	E077145003-H
2.5-15 Gallon	2" NPTF	E074171001-H	E074179001-H	E074173001-H	E074177001-H	E074175001-H
	#24 SAE	E074171002-H	E074179002-H	E074173002-H	E074177002-H	E074175002-H
	1 1/2" Code 62 Flange	E077131003-H	E077139003-H	E077133003-H	E077137003-H	E077135003-H
	1 1/4" NPTF	E074171004-H	E074179004-H	E074173004-H	E074177004-H	E074175004-H

5,000 PSI (ASME), 690 Bar (PED) Hydraulic Port Kit Part Numbers (*Oil or Water Service)						
Size	Port Style	Bladder Bag Compound				
		Buna	Hydrin	Butyl	EPR	Fluoroelastomer
1 Gallon	1 1/4" NPTF	E076781*01	E076789*01	E076783*01	E076787*01	E076785*01
	#20 SAE	E076781*02	E076789*02	E076783*02	E076787*02	E076785*02
	1 1/4" Code 62 Flange	E076781*03	E076789*03	E076783*03	E076787*03	E076785*03
2.5-15 Gallon	2" NPTF	E074181*01	E074189*01	E074183*01	E074187*01	E074185*01
	#24 SAE	E074181*02	E074189*02	E074183*02	E074187*02	E074185*02
	1 1/2" Code 62 Flange	E074181*03	E074189*03	E074183*03	E074187*03	E074185*03

* = "O" (Standard Oil Service) * = "W" (Water Service)

5,000 PSI (ASME), 690 Bar (PED) Hydraulic Port Kit Part Numbers (Chemical Service)						
Size	Port Style	Bladder Bag Compound				
		Buna	Hydrin	Butyl	EPR	Fluoroelastomer
1 Gallon	1 1/4" NPTF	E076781001-H	E076789001-H	E076783001-H	E076787001-H	E076785001-H
	#20 SAE	E076781002-H	E076789002-H	E076783002-H	E076787002-H	E076785002-H
	1 1/4" Code 62 Flange	E076781003-H	E076789003-H	E076783003-H	E076787003-H	E076785003-H
2.5-15 Gallon	2" NPTF	E074181001-H	E074189001-H	E074183001-H	E074187001-H	E074185001-H
	#24 SAE	E074181002-H	E074189002-H	E074183002-H	E074187002-H	E074185002-H
	1 1/2" Code 62 Flange	E074181003-H	E074189003-H	E074183003-H	E074187003-H	E074185003-H

For 1 Quart BA Assemblies Prior to July 2016
 Please order the 1 Pint Hydraulic Port Kit. Example: Use L075031002 instead of E074151002.



Hydraulic Assembly Port Numbers





3,000 PSI (Non-ASME or ASME), 330 Bar (PED) (No Seals, Port Only)					
Size	Port Style	Oil Service	Water Service	Chemical Service	
10 Cu. In.	3/4" NPTF MALE	L076740001	L076740w01	Not Available in Catalog (Call Factory)	
	#8 SAE	L076740002	L076740w02		
1 Pint	3/4" NPTF	L075030001	L075030w01		
	#12 SAE	L075030002	L075030w02		
1 Qt/150 Cu. In.	1" NPTF	E074350001	E074350w01		
	#16 SAE	E074350002	E074350w02		
1 Gallon	1 1/4" NPTF	E074360001	E074360w01		E074360001-H
	#20 SAE	E074360002	E074360w02		E074360002-H
	1 1/4" Code 62 Flange	E087019304	E087019304w		E087019304-H
2.5-15 Gallon	2" NPTF	E074370001	E074370w01		E074370001-H
	#24 SAE	E074370002	E074370w02	E074370002-H	
		E074370003	E074370w03	E074370003-H	
	1 1/4" NPTF	E074370005	E074370w05	E074370005-H	

5,000 PSI (ASME), 690 Bar (PED) (No Seals, Port Only)				
Size	Port Style	Oil Service	Water Service	Chemical Service
1 Gallon	1 1/4" NPTF	E076770001	E076770w01	E076770001-H
	#20 SAE	E076770002	E076770w02	E076770002-H
	1 1/4" Code 62 Flange	E076770003	E076770w03	E076770003-H
2.5-15 Gallon	2" NPTF	E074420001	E074420w01	E074420001-H
	#24 SAE	E074420002	E074420w02	E074420002-H
	1 1/2" Code 62 Flange	E074420003	E074420w03	E074420003-H



Transport of BA Series Accumulators

Due to their cylindrical shape, BA Series Accumulators have a tendency to roll or fall over. This may lead to property damage or personal injury. Make sure the accumulator safely is secured against unintended rolling or falling. Use appropriate lifting equipment for BA Series accumulators with a capacity of 2.5 gallons (9.5 liters) or more are lifted. Make sure that the load capacity of the lifting gear is sufficient in order to safely carry the weight of the BA Series accumulator. Details on the weights of each size Accumulator can be found in Parker's Catalog HY10-1630 or visit our website at www.parker.com/acdsupport. When BA Series accumulators are pressurized, external impact can damage the vessel and further lead to product rupture or property damage.

Never:

-  **Hit, drop or apply force to the accumulator**
-  **Use the gas valve or bladder stem as a lifting mechanism**
-  **Place objects on top of the accumulator**
-  **Use the accumulator as a support structure**
-  **Use the accumulator as a step or handle**

Remember:

-  Prior to transporting, the hydraulic port opening and gas valve should be covered with their appropriate protective caps. This prevents dirt or water from penetrating into the accumulator and protects the threads and gas valve from damage.
-  To prevent internal damage to the bladder and to seat the poppet valve on the hydraulic port, BA Series accumulators should be transported with a holding charge of 29 PSIG (2 bar). If the bladder-type accumulator is transported with a higher pressure, it must be declared as hazardous material. BA Series Accumulators are considered as dangerous goods UN 3164, Articles, Pressurized, Hydraulic or Pneumatic, non-flammable gas 2.2 when the accumulator is pre-charged with compressed nitrogen on road, rail and sea. Parker doesn't recommend transporting any pre-charged accumulators (greater than 29 PSIG or 2 bar) via air. For this reason, any shipping company transporting pressurized accumulators should have qualified personnel. For transport in North America, Parker has a special permit from the Department of Transportation. This special permit can be found on our website at www.parker.com/acdsupport. For any other country outside of North America, consult your carrier for transportation rules and regulations of pressurized vessels.

Installation of New Accumulator

The installation must be carried out by qualified hydraulic personnel with the proper hydraulic system schematic. Carefully unpack the accumulators by removing them from their wooden crate or loosening the plastic strapping around the skid on a flat surface. This will prevent unintentional rolling that could lead to injuries or damage. Lift the bladder-type accumulator out of the package by using appropriate lifting equipment. (See Transport of BA Series Accumulators Section in this guide.) Dispose of the packaging in accordance with the recommendations applicable in your country.

Allow the bladder-type accumulator to acclimate with the ambient temperature environment the system is in. The accumulator should be mounted within 25° of vertical with the hydraulic port on the bottom. There should be approximately 10 inches (250 mm) of clearance above the gas valve to be able to connect the charging and gauging assemblies. Due to their heavy weight, they should be rigidly mounted using appropriate mounting hardware. Parker recommends the use of a U-bolt and base plate or clamp style brackets (See **Figure H**). Information on recommended brackets for each size accumulator can be found in Parker's Catalog HY10-1630 or visit our website at www.parker.com/acdsupport.

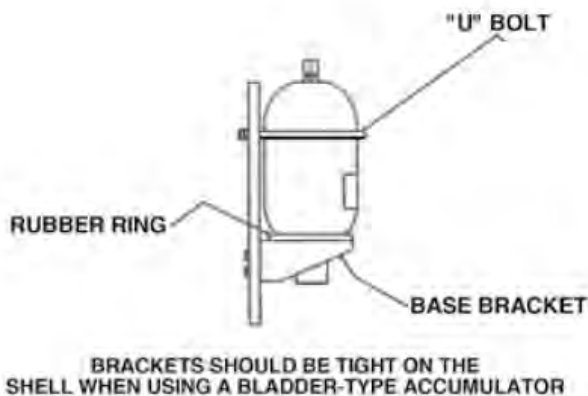

⚠ The hydraulic circuit should be designed so that it automatically discharges all the hydraulic fluid from the accumulator when the equipment is turned off. According to the Pressure Equipment Directive 2014/68/EU (formerly 97/23/EC), bladder accumulators must be secured with a safety block which ensures all hydraulic fluid is discharged once the system is turned off. See Parker's Catalog HY10-1630 for more information on Safety Blocks.

The accumulators should be installed in a clean environment. Contamination may reduce the service life of the accumulator. Make sure the accumulator is free of any residual oil. Clean the accumulator with dry, non-fiber cloths.

Remove the protective cap from the oil port of the bladder accumulator. Connect and properly tighten the hydraulic lines to the oil port of the bladder-type accumulator or the safety block, if installed. The BA Series Accumulator is now mounted and installed.

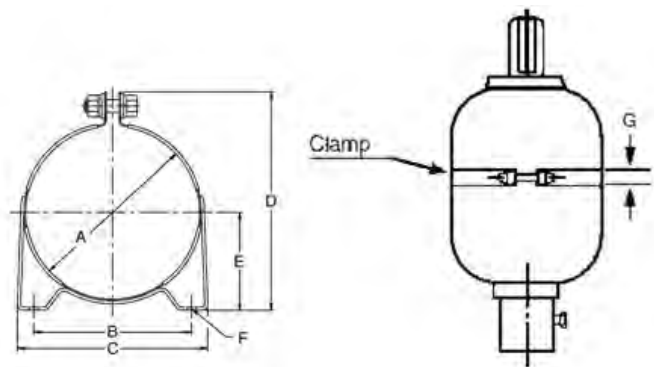

Figure H

Prepare for Commissioning

Prior to commissioning, verify or review the following:

- ⚠ Make sure that the accumulator is fully intact, hydraulic lines and safety blocks are properly tightened and leak free.

Review that the BA Series accumulator corresponds to the system specification, hydraulic schematic or the system’s bill of materials.

Verify the fluid used in the hydraulic system is compatible with the seals and bladder within the accumulator.

- ⚠ Ensure the operating temperatures are within the limits mentioned on the accumulator’s label.
- ⚠ Make sure the maximum operating pressure on the accumulator’s label is equal to or greater than the maximum operating pressure of the hydraulic system.
- ⚠ Since the product is only supplied with a primer coat, a top coat may be required in order to ensure the required corrosion protection.



Figure 1: Pull rods, Spanner wrench, Core repair tool, and Core installation tool

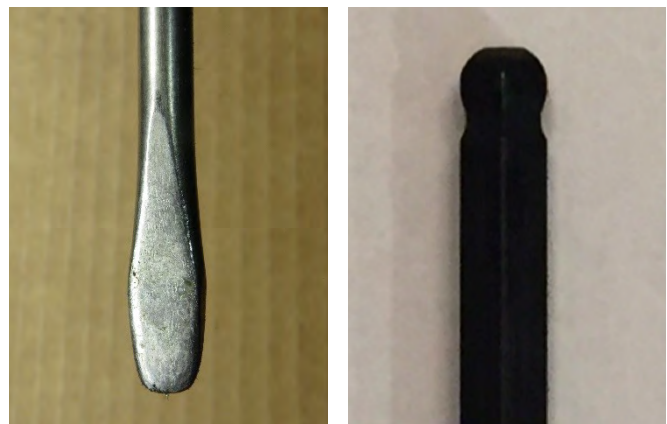

Figure 2: Typical rounded edge flathead screwdriver or ball head hex

Tools and Equipment		
Description	Part Number	Use
Charging & Gauging Assembly	See section on next page	Various styles available based on pre-charge, accumulator size & style.
Pull Rod (1 Qt - 2 ½ Gallon)	085109 0250	Pull rods are available in single or multiple lengths for different size accumulators. The pull rods attach to the gas valve of the bladder for ease of assembly into shell during assembly.
Pull Rod (5 Gallon)	085109 0500	
Pull Rod (10-11 Gallon)	085109 1000	
Pull Rod (15 Gallon)	085109 1500	
Core Repair Tool	582441 0000	Fits all standard size bladder accumulators. Used to remove hydraulic port assembly from the accumulator.
Core Installation Tool	300987	
Spanner Wrench	085110 0000	Rounded edges. Used to tuck in hydraulic port O-ring.
Box Or Adjustable Wrenches		
Blunt Flathead Screwdriver or Ball Head Hex Wrench	See pictures above	Used to establish proper torque
Torque Wrench		
Soft Head Hammer		May be required to loosen locking ring in conjunction with spanner wrench

Charging & Gauging Assemblies (Based on Pre-Charge, Accumulator Size & Style):

Part Number	Charging & Gauging Assemblies for Pre-Charge < 3000 PSI (207 Bar)	Figure
CG-3000A	Charging and Gauging Assembly consists of 10' charging hose with a CGA 580 right-hand thread fitting, an adapter incorporating gas valve, bleed valve, gas chuck, & gauge.	3

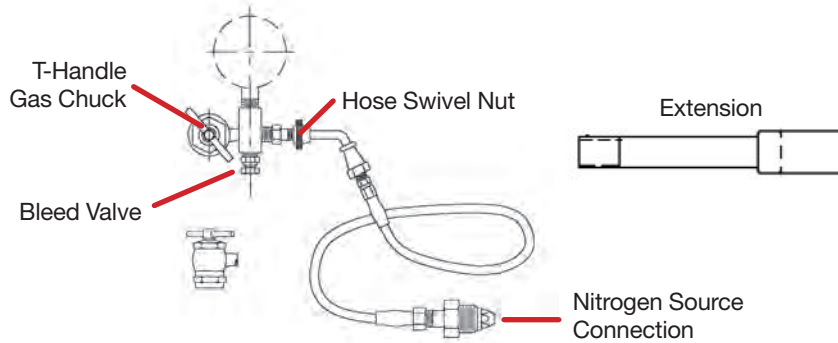

Figure 3

Part Number	Charging & Gauging Assemblies for 25-40 Gallon Units With < 3000 PSI Pre-Charge & all Units < 6000 PSI (414 Bar)	Figure
CG-6000	Charging and Gauging Assembly consists of 10' charging hose with a CGA 677 left-hand female thread fitting, an adaptor incorporating gas valve, bleed valve, gas chuck, & gauge.	4

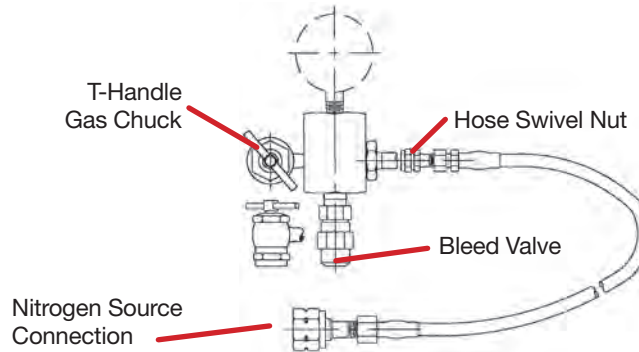

Figure 4

Part Number	Charging & Gauging Assemblies for Pre-Charge < 10,000 PSI (690 Bar)	Figure
CG-10K	Charging and Gauging Assembly consists of 10' charging hose with a CGA 677 left-hand female thread fitting, an adaptor incorporating gas valve connection, gas valve, bleed valve, & gauge. The CGA 677 connection is rated for 6000 psi nitrogen tanks. For higher pre-charge pressures, this fitting must be removed when connecting to a nitrogen gas booster.	5

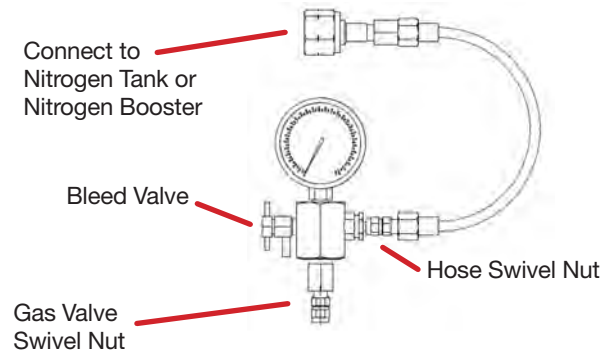

Figure 5

Pre-Charging an Accumulator

⚠ Only use an inert gas like nitrogen for a pre-charging. Nitrogen that is 99.99 percent by volume is strongly recommended. **Do not use oxygen or shop air**, as this may lead to a fire or explosion. **It is strongly recommended that the nitrogen bottle used have the appropriate high pressure regulator (not included).**

Pre-Charge Instructions

Select the proper Charging & Gauging Assembly based on the nitrogen tank's thread direction, the accumulator's volume, and the accumulator's design pressure based on the charts on page 17. If other equipment is used, make sure it is compatible with the gas valve assembly and nitrogen source.

⚠ All components must be rated for a pressure at least as high as the nitrogen source.

Make sure nitrogen supply is shut off. Attach the hose's nitrogen tank connector to the nitrogen bottle. If accumulator has a Core Style Gas Valve as shown in **Figure 6A** or **6B**, follow steps A through L and skip steps F and J. If accumulator has a Poppet Style or Military Style per MS28889-2 Gas Valve (Item 26) as shown in **Figure 7**, follow steps A through L and skip steps E and I. If an accumulator requires a pre-charge >6000 PSI (414 bar) and has a High Pressure Gas Valve as shown in **Figure 7**, follow instructions for pre-charging up to 10,000 PSI (690 bar).

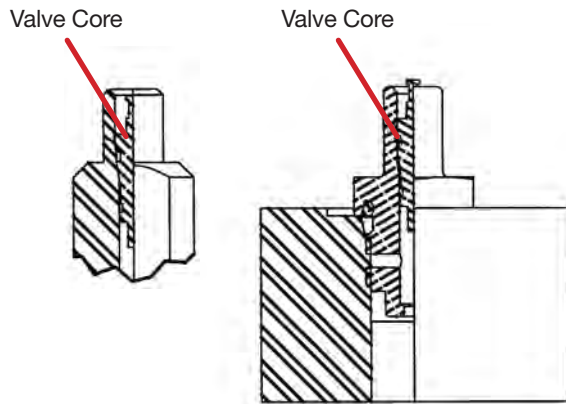

Figure 6A Figure 6B
Core Style Gas Valves

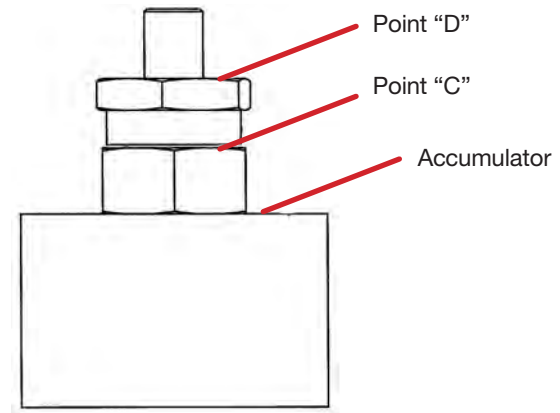

Figure 7
Poppet/Military/High Pressure
Style Gas Valves

Accumulators With Gas Valve Per Figure 6A Or 6B And <3000 PSI (407 Bar) Pre-Charge

- A** If present, remove protective cap (Item 6) and gas valve cap (Item 29).
- B** Back gas chuck “T” (as shown in **Figures 3-4**) handle all the way out (counterclockwise) before attaching charging assembly to accumulator gas valve (Item 26).
- C** Close bleed valve (as shown in **Figures 3-4**).
- D** If hose isn’t attached to charging and gauging assembly, attach the hose to the hose gas valve on the charging and gauging assembly by tightening the hose swivel nut (as shown in **Figures 3-4**) to (10-15 in. lb.) (1.1-1.7 N-m). Make sure not to loop or twist the hose.
- E** Attach swivel nut on gas chuck (as shown in **Figures 3-4**) to the accumulator’s gas valve (Item 26). Tighten swivel nut to (10-15 in. lb.) (1.1-1.7 N-m).
- F** Turn gas chuck “T” handle until the gauge starts showing the pressure in the accumulator. Do not turn the “T” handle all the way down, as it will damage the valve core.
- G** For accumulators with gas valves as shown in **Figure 7** and <6000 PSI (414 bar) pre-charge, hold gas valve at point “C” with one (1) wrench while unscrewing hex nut at point “D” with a second wrench. This will open the poppet inside the gas valve. Note: Three (3) turns will fully open the valve.
- H** Crack open nitrogen bottle or regulator valve and slowly fill accumulator. Shut off when gauge indicates 100 PSI above desired pre-charge. For shock suppression applications, pre-charge is usually set at about 65% of system pressure. When the accumulator is used to supplement pump flow, auxiliary power supply or leakage compensation, pre-charge is usually set at approximately 90% of minimum system pressure.
- I** Let the pre-charge set for 10 to 15 minutes. This will allow the gas temperature to stabilize. If the desired pre-charge is exceeded, close nitrogen bottle valve, then slowly open bleed valve.
- J** When finished pre-charging the accumulator, turn “T” handle all the way out (counterclockwise) on the gas chuck. Then open the bleed valve. (As shown in **Figures 3-4**)
- K** For gas valves as shown in **Figure 7**, with a wrench, tighten hex nut at point “D” to close internal poppet (5-8 ft. lbs.) (6.8- 10.8 N-m).
- L** Hold gas valve to keep from turning, loosen gas chuck swivel nut (as shown in **Figures 3-4**), and remove assembly. Check for pre-charge leak using a common leak reactant.
- M** Replace gas valve cap (Item 29) and torque to (12-24 in. lbs.) (1.4-2.7 N-m) and protective cap (Item 6) (Gas valve cap serves as a secondary seal.)
- ⚠** If the pre-charge is not done slowly, the bladder may suffer permanent damage.
- ⚠** It is recommended that pre-charge pressure be at least 25% of maximum system pressure. Damage to bladder may occur if this ratio is not maintained or is exceeded.
- ⚠** Do not reduce pre-charge by depressing valve core (Item 4) with a foreign object. High pressure may rupture rubber valve seat.

Accumulators Rated for 10,000 PSI (690 Bar) or Less With Gas Valve Per Figure 7

- A** If present, remove protective cap (Item 6) and gas valve cap (Item 29).
- B** Use charging and gauging assembly, Parker Part CG-10K, as shown in **Figure 5**. Close bleed valve on **Figure 5**. Attach nitrogen hose connection to a nitrogen source. (A Nitrogen Gas Booster may be required for pre-charge pressure greater than 6000 PSI (414 bar).
- C** If hose isn't attached to charging and gauging assembly, attach the hose to the hose gas valve on the charging and gauging assembly by tightening the hose swivel nut as shown in **Figure 5** to (10-15 in. lb.) (1.1-1.7 N-m). Making sure not to loop or twist the hose.
- D** Tighten the gas valve swivel nut shown in **Figure 5** to the accumulator's gas valve (Item 26). Torque to 10-15 in. lb. (1.1-1.7 N-m)
- E** Referring to **Figure 7**, hold gas valve at point "C" with one (1) wrench while unscrewing hex nut at point "D" with a second wrench. This will open the poppet inside the gas valve. Note: Four (4) turns will fully open the poppet.
- F** Crack open nitrogen bottle or regulator valve and slowly fill accumulator. Shut off when gauge indicates 100 PSI (7 Bar) above desired pre-charge.
- ⚠** If the pre-charge is not done slowly, the bladder may suffer permanent damage.
- ⚠** It is recommended that pre-charge pressure be at least 25% of maximum system pressure. Damage to bladder may occur if this ratio is not maintained or is exceeded.
- G** Let the pre-charge set for 10 to 15 minutes. This will allow the gas temperature to stabilize. If the desired pre-charge is exceeded, close nitrogen bottle valve, then slowly open bleed valve on **Figure 5** until desired pressure is reached.
- H** Upon closing the gas valve (Item 26), a greater amount of torque is required, thereby indicating a charged system. With a wrench, tighten hex nut at point "D" on **Figure 7** to close internal poppet. Torque to 220-225 inch-lb or (24.9-25.4 N-m). The gas valve assembly could become damaged beyond repair if this torque value is exceeded.
- I** Hold gas valve at point "C" per **Figure 7** to keep from turning and then open bleed valve on **Figure 7** to relieve pressure inside the charging assembly. Next, loosen the gas valve swivel nut on **Figure 5** and remove charging assembly. Check for pre-charge leak using a common leak reactant.
- J** Replace gas valve cap (Item 29) and torque to (12-24 in. lbs.) (1.4-2.7 N-m) and protective cap (Item 6). Gas valve cap serves as a secondary seal.

Monitoring & Maintenance

Little maintenance is required for a bladder accumulator. If there is external leakage, tighten all connections. If leakage continues, remove accumulator from system and replace faulty components. After original installation, check pre-charge once during first week to see that no leak has developed. Thereafter, if not specified by the hydraulic system's maintenance manual, check pre-charge monthly. Check pre-charge if the system is acting sluggish. If pre-charge is low, check gas valve for leakage and recharge. If there is no gas in the bladder and hydraulic fluid appears at gas valve, unit must be removed and the bladder replaced.

Pre-Charge Checking Procedure

Using the appropriate valve in the hydraulic system, discharge all oil from accumulator and allow the poppet valve to close. Then follow the appropriate instructions below based on the pressure rating of the accumulator.

For BA Series Accumulators Rated Less Than 3000 PSI (207 Bar) Units With a Gas Valve Shown in Figure 6A & 6B:

- A** Remove protective cap (Item 6) and gas valve cap (Item 29).
- B** Close bleed valve and turn "T" handle (as shown in Figures 3-4) all the way out.
- C** Follow one of the following to attach charging and gauging assembly to accumulator:
 - a. For 10 cubic inch – 15 Gallon, 3000 PSI bottom repairable units as shown in Figures A & B:** Use Parker CG-3000 as shown in Figure 3. An o-ring/ sealing washer (Item 3) will need to be installed onto the accumulator's gas valve (Item 26) prior to attaching this charging and gauging assembly to the accumulator's bladder valve stem (Item 2). Attach charging and gauging assembly to accumulator's gas valve (Item 26) and via the gas chuck's swivel nut and tighten to (10-15 in. lb.) (1.1-1.7 N-m).
 - b. For 3000 PSI top repairable units as shown in Figure C:** Use Parker CG-3000A as shown in Figure 3. An o-ring/sealing washer (Item 3) will need to be installed onto the accumulator's gas valve (Item 26) prior to attaching this charging and gauging assembly to the accumulator's bladder valve stem (Item 2). A Gas Valve Extension is required for all 3000 PSI Top Repairable Accumulators. The extension can be found in the CG-3000A kit. Attach the extension to the gas chuck in Figure 3. Then attach charging and gauging assembly via the extension to the accumulator's gas valve (Item 26). Tighten to (10-15 in. lb.) (1.1-1.7 N-m).
- D** Turn "T" handle, as shown in Figure 3, all the way down, which will depress core (Item 4) in gas valve and check pressure.
- E** Read pre-charge. If pre-charge is satisfactory, continue to Step F. If pre-charge is low, follow Pre-Charging Instructions (H-I).
- F** To remove gauging assembly, turn "T" handle all the way out and then open bleeder valve. (As shown in Figure 3.)
- G** Prevent gas valve (Item 26) from turning, loosen swivel nut on the gas valve chuck and remove assembly.
- H** Install cap (Item 29) on gas valve (12-24 in. lb.) (1.4-2.7 N-m) and protective cap (Item 6).

For All BA Series Accumulators Rated Less Than 5000 PSI (345 Bar) or 25-40 Gallon, 3000 PSI (207 Bar) Rated Units With a Gas Valve Shown in Figure 7:

- A** Remove protective cap (Item 6) and gas valve cap (Item 29).
- B** Close bleed valve and turn “T” handle (as shown in **Figure 4**) all the way out.
- C** Use Charging and gauging assembly, Parker CG-6000, as shown in **Figure 4**. Attach charging and gauging assembly to accumulator’s gas valve (Item 26) via the gas chuck’s swivel nut and tighten to (10-15 in. lb.) (1.1-1.7 N-m).
- D** Referring to **Figure 7**, hold gas valve (Item 26) at point “C” with one (1) wrench while unscrewing hex nut at point “D” with a second wrench. This will open the poppet inside the gas valve. Note, four (4) turns will fully open poppet valve.
- E** Check pre-charge. If pre-charge is satisfactory, continue to Step F. If pre-charge is low, follow Pre-Charging Instructions (H-I).
- F** With wrench, tighten hex nut at point “D” to close internal poppet (10-15 in. lb.) (1.1-1.7 N-m).
- I** Hold gas valve at point “C” with a wrench and loosen swivel nut on the gas valve chuck and remove charging and gauging assembly.
- G** Replace cap (Item 29) on gas valve (12-24 in. lb.) (1.4-2.7 N-m) and install protective cap (Item 6).

For BA Series Accumulators Rated Less Than 10,000 PSI (690 Bar) Units With a Gas Valve Shown In Figure 7:

- A** If present, remove protective cap (Item 6) and gas valve cap (Item 29).
- B** Use charging and gauging assembly, Parker CG-10K, as shown in **Figure 5**.
- C** Close bleed valve on **Figure 5**.
- D** Making sure not to loop or twist the hose, attach the charging and gauging assembly’s gas valve swivel nut on **Figure 5** to gas valve (Item 26) in **Figure 7** and tighten (10-15 in. lb.) (1.1-1.7 N-m).
- E** Referring to **Figure 7**, hold gas valve at point “C” with one (1) wrench while unscrewing hex nut at point “D” with a second wrench. This will open the poppet inside the gas valve. Note: Four (4) turns will fully open the poppet.
- F** Read pre-charge. If pre-charge is satisfactory, continue to Step G. If pre-charge is low, follow 10,000 PSI Pre-Charging Instructions (6-7).
- G** Upon closing the gas valve (Item 26), a greater amount of torque is required, thereby indicating a charged system. With a wrench, tighten hex nut at point “D” on **Figure 7** to close internal poppet. Torque to 220-225 inch-lb or (24.9-25.4 N-m). The gas valve assembly could become damaged beyond repair if this torque value is exceeded.
- H** Hold gas valve at point “C” per **Figure 7** to keep from turning and then open bleed valve on **Figure 5** to relieve pressure inside the charging assembly. Next, loosen the gas valve swivel nut on **Figure 5** and remove charging assembly.
- I** Replace gas valve cap (12-24 in. lbs.) (1.4-2.7 N-m) and protective cap. Gas valve cap serves as a secondary seal.

Removal of Accumulator From the Hydraulic System

Shut equipment down and make certain that hydraulic pressure at the accumulator is at zero. Remove protective cap (Item 6) and gas valve cap (Item 29).

3000 PSI Rated Units

Accumulators rated for 3000 PSI will have a gas valve (Item 26) as shown in **Figure 6A** or **6B**. For these units, attach gaging assembly Parker CG-3000A. Open bleed valve and release all the gas pressure.

WARNING: Keep face and hands away from bleed valve, as high pressure nitrogen is discharging.

Detach gauging assembly and, using valve core removing tool (Part #5824410000), remove valve core (Item 4). Remove accumulator from hydraulic system.

25-40 Gallon 3000 PSI (207 Bar) and all 5000 PSI (345 Bar) & 10,000 PSI (690 Bar) Rated Units Equipped With a Gas Valve as Shown in Figure 7

The accumulators mentioned above will have a gas valve (Item 26) as shown in **Figure 7**. For these units, after removing valve cap (Item 29), hold valve at point "C" with one (1) wrench while unscrewing hex nut at point "D" with a second wrench until gas begins to escape through the top of the gas valve (Item 26). Wait until all the gas pressure has been released.

WARNING: Keep face and hands away from bleed valve, as high pressure nitrogen is discharging.

Remove the gas valve (Item 26) from the accumulators and then remove accumulator from hydraulic system.

Disassembly of Bottom Repairable Accumulators

Figure 1: Once the accumulator has been removed from the equipment, the accumulator body should be secured in a vise, preferably a chain vise. If a standard jaw vise is used, brass inserts should be used to protect the accumulator hydraulic port assembly (Item 7) from damage. Clamp on wrench flats only when using a jaw vise to prevent accumulator from turning.



Figure 1

Figure 2: Remove bleeder plug (Item 21), if the accumulator is equipped with one, on hydraulic port assembly.



Figure 2

Figure 3: Using a spanner wrench, 0851100000, remove lock ring (Item 8) from the hydraulic port assembly (Item 7); use an adjustable wrench on the flats located on the port assembly to prevent port assembly from rotating. Remove spacer (Item 10), then push the hydraulic port assembly (Item 7) into the shell (Item 1) prior to Step 4.



Figure 3

Figure 4: Insert hand into the accumulator shell (Item 1) and remove the o-ring backup (Item 16), o-ring (Item 14), and metal backup (Item 18). Separate the anti-extrusion ring (Item 12) from the hydraulic port (Item 7). Fold anti-extrusion ring to enable removal of anti-extrusion ring from shell.



Figure 4

Figure 5: Remove hydraulic port assembly (Item 7) from accumulator shell (Item 1).



Figure 5

Figure 6: Remove hex jam nut (Item 5) from bladder valve stem (Item 2). Prevent valve stem from twisting with an appropriate wrench applied to the valve stem flats.

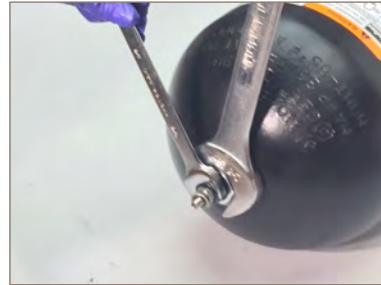

Figure 6

Figure 7: Fold bladder (Item 2) and pull out of accumulator shell (Item 1). A slight twisting motion while pulling on the bladder reduces effort required to remove bladder from shell. If bladder is slippery, hold with a cloth.



Figure 7

Clean & Inspect

Cleaning: All metal parts should be cleaned with a cleaning agent. Seals and soft parts should be wiped clean.

Bladder (Item 2): Inflate bladder to normal size. Wash bladder with a soap solution. If soap solution bubbles, discard bladder. After testing, deflate bladder immediately.

Hydraulic Port Assembly (Item 7): Inspect assembly for damage. Check the poppet valve (Item 7.2) and spring (Item 7.4) to see that the poppet spins freely and the spring functions properly. In cases where the accumulator is used with water, check assembly for rust and/or defective plating. If rust is detected, clean with commercial rust remover. If parts are pitted, replace with new components. If protective plating is damaged, replace with new components.

Seals: Check anti-extrusion ring (Item 12) and soft seals for damage and wear. Replace all worn and damaged seals with Parker's original equipment seals.

Shell (Item 1): After shell has been cleaned with a cleansing agent, check the inside and outside of shell. Special attention should be given to the area where the bladder stem (Item 2) and hydraulic port assembly (Item 7) pass through the shell. Any nicks or damages in this area could destroy the accumulator bladder or damage new seals. If this area is pitted, consult the factory.

Bladder Assembly in Bottom Repairable Accumulators

Figure 8: After shell (Item 1) has been cleaned and inspected, place accumulator shell in vise or on table. Spray the inside of the accumulator shell with a liberal amount of clean system hydraulic fluid to lubricate and cushion the bladder (Item 2). Make sure the entire inside of the shell is lubricated.

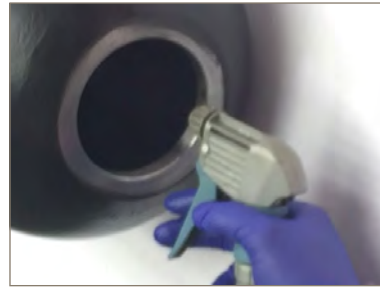

Figure 8

Figure 9: Insert the bladder pull rod, 085109xxxx, through both the shell's valve stem opening and fluid port opening. Attach the bladder pull rod to the bladder valve stem (Item 26).



Figure 9

Figure 10: With all gas completely exhausted from bladder (Item 2), collapse bladder and fold longitudinally in a compact roll. With one hand, pull the bladder pull rod while feeding the bladder (Item 2) into the shell (Item 1) with the other hand. Slight twisting of bladder will assist in this insertion.



Figure 10

Figure 11: Once the bladder valve stem has been pulled through the valve stem opening in the shell, install the valve stem hex nut (Item 5) by hand. Once the valve stem hex nut is in place, remove the bladder pull rod.



Figure 11

Figure 12: Thread hex jam nut (Item 5) onto bladder valve stem (Item 2). Secure valve stem from twisting with an appropriate wrench applied to the valve stem flats. Torque jam nut to proper torque based on accumulator size per the Suggested Approximate Torque Values on page 7 of this guide.

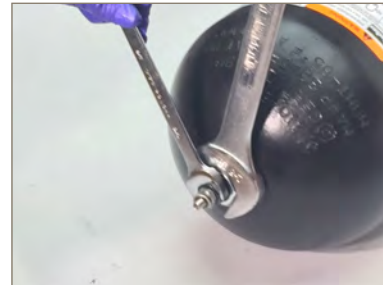

Figure 12

Disassembly of Conventional Top-Repairable Accumulators

The conventional top-repairable accumulator uses a gas-end adapter (Item 23) which is retained in the shell with an anti-extrusion ring (Item 12) exactly like those used in port assemblies. (See **Figure 10**)

- 1 Make sure the gas is relieved from the accumulator. (See Removal of Accumulator from System.)
- 2 Remove hex jam nut (Item 5) from bladder gas valve stem (Item 2) using a 1-5/16" socket wrench.
- 3 Using a spanner wrench, 085110 0000, remove outer lock ring (Item 8) on the gas end adapter (Item 23).
- 4 Push the gas end adapter (Item 23) complete with the bladder (Item 2) into the shell (Item 1).
- 5 Insert hand into accumulator, remove the o-ring back-up (Item 16), o-ring (Item 14), and metal back-up (Item 18). Separate the anti-extrusion ring (Item 12) from the gas end adapter (Item 23).
- 6 Fold the anti-extrusion ring (Item 12) and remove from shell (Item 1). (See **Figure 4**).
- 7 Remove gas end adapter (Item 23) from shell.
- 8 Remove bladder (Item 2) from shell.

NOTE: Conventional top repairable accumulators may be repaired by removing the bladder from either the hydraulic end or the gas end of the accumulator.

Clean & Inspect

Cleaning: All metal parts should be cleaned with a cleaning agent. Seals and soft parts should be wiped clean.

Bladder (Item 2): Inflate bladder to normal size. Wash bladder with a soap solution. If soap solution bubbles, discard bladder. After testing, deflate bladder immediately.

Hydraulic Port Assembly (Item 7): Inspect assembly for damage. Check the poppet valve (Item 7.2) and spring (Item 7.4) to see that the poppet spins freely and the spring functions properly. In cases where the accumulator is used with water, check assembly for rust and/or defective plating. If rust is detected, clean with commercial rust remover. If parts are pitted, replace with new components. If protective plating is damaged, replace with new components.

Seals: Check anti-extrusion ring (Item 12) and soft seals for damage and wear. Replace all worn and damaged seals with Parker's original equipment seals.

Shell (Item 1): After shell has been cleaned with a cleansing agent, check the inside and outside of shell. Special attention should be given to the area where the gas valve and hydraulic assembly pass through the shell. Any nicks or damages in this area could destroy the accumulator bladder or damage new seals. If this area is pitted consult factory.

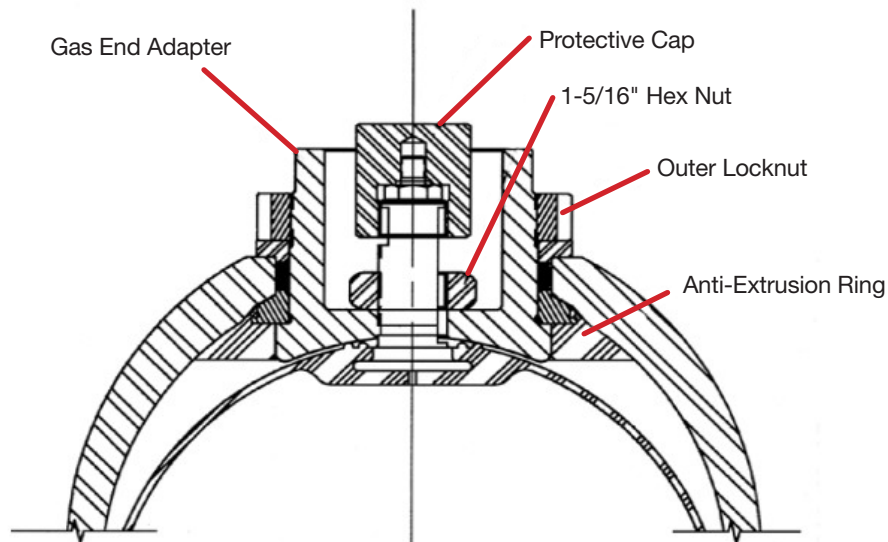

Figure 13

Bladder Assembly in Conventional Top-Repairable Accumulators

- 1 Spray the inside of the accumulator shell (Item 1) with a liberal amount of clean system hydraulic fluid to lubricate and cushion the bladder. Make sure the entire inside of the shell is lubricated.
- 2 With all gas completely exhausted from bladder, collapse bladder (Item 2) and fold longitudinally in a compact roll.
- 3 Install the gas end adapter (Item 23) on the bladder and secure with hex jam nut (Item 5). Torque hex jam nut to 100-120 ft-lb (136-163 N-m).
- 4 Insert bladder/adapter assembly into accumulator shell.
- 5 Fold anti-extrusion ring (Item 12) and place inside accumulator.
- 6 Reaching inside the accumulator, insert the gas end adapter (Item 23) through the anti-extrusion ring (Item 12) and pull into place. The steel surface on anti-extrusion ring should face outward.
- 7 Holding the gas end adapter (Item 23) in place, fill accumulator with approximately 50 PSI nitrogen. This will hold the gas end adapter in place.
- 8 Install the metal backup (Item 18), o-ring (Item 14), and o-ring backup (Item 16).
- 9 Install the outer spacer (Item 10).
- 10 Install the outer locking ring (Item 8).

Hydraulic Port Assembly Installation

- 1 Holding the hydraulic port assembly (Item 7) by the threaded end, insert the poppet end into the shell fluid port. Lay complete assembly inside shell (Item 1).
- 2 **Figure 14:** Fold anti-extrusion ring (Item 12) to enable insertion into the shell. Once the anti-extrusion ring has cleared the hydraulic fluid port opening, place the anti-extrusion ring on the hydraulic port assembly (Item 7) with the port assembly's steel collar end facing toward the shell fluid port.



Figure 14

- 3 Pull the threaded end of the port assembly (Item 7) through the shell fluid port until it sits solidly into position on the shell's fluid port opening.
- 4 **Figure 15:** With port assembly firmly in place, install valve core (Item 3) or gas valve (Item 26) into the bladder stem (Item 2). Slowly pressurize the bladder, using dry nitrogen with sufficient pressure (approximately 40-50 PSI) to hold hydraulic port assembly (Item 7) in place so both hands are free to continue with assembly.

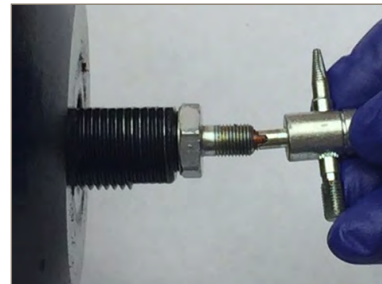

Figure 15

- 5 **Figure 16:** Install metal backup washer (Item 18) over hydraulic port assembly and push into the shell fluid port to bottom it out on the anti-extrusion ring (Item 12).



Figure 16

- 6 **Figure 17:** Install O-ring (Item 14) over hydraulic port assembly (Item 7) and push it using a blunt, rounded edge, flathead screw driver or a ball head hex into the shell's fluid port until it bottoms out against the washer.

CAUTION: Do not twist or damage o-ring.



Figure 17

- 7 Install o-ring backup (Item 16) over hydraulic port assembly (Item 7) and push until it bottoms against o-ring (Item 14) (1-40 gallon sizes and 5K only).

- 8 **Figure 18:** Insert spacer (Item 10) with the smaller diameter of the shoulder facing the accumulator shell.



Figure 18

- 9 Figure 19:** Install the locking ring (Item 8) on the hydraulic port assembly (Item 7). Using a spanner wrench, 0851100000, tighten securely per the Suggested Approximate Torque Values on page 11 of this guide. This will squeeze the O-ring (Item 14) into position. Use appropriate wrench on flats of hydraulic port assembly (Item 7) to ensure the unit does not turn.



Figure 19

- 10 Figure 20:** Thread bleeder plug (Item 21) into the hydraulic port assembly (Item 7).
- 11** Position accumulator so that fluid (same fluid as used in system) can be poured into the accumulator (add approximately 10% of the accumulator capacity). This fluid will act as a cushion when the accumulator is pre-charged with gas.
- 12** Pre-charge accumulator to desired pressure. See pre-charge instructions.
- 13** Install accumulator on machine.



Figure 20

Bladder Accumulator Storage

BA Series Accumulators are supplied with a primer coat. Under the following conditions, this coat will provide as new condition for up to 3 years:

- The storage facility must be cool, dry, and constant.
- Storage temperature should be between 50°F and 90°F (10°C – 32°C).

Procedure after expiration of maximum shelf life:

- Visually examine the bladder accumulator for any damage and corrosion.
- If rust is detected, remove and repaint. If parts are pitted, replace with new components. If protective plating is damaged, replace with new components.
- Replace the bladder, seals, and gas valve by way of precaution.

⚠ Please note that the warranty period is not prolonged by the storage time.

Bladder Storage

Normal storage life (Up to 1 year from date of shipment):

- Storage conditions consist of the bladder being heat sealed in a 5 mil minimum black polyethylene bag or a 3 mil minimum U.V. resistant bag. It should then be placed in a cool dry place away from direct sun, ultraviolet & fluorescent lights, as well as ozone producing electrical equipment (ie. Fans or motors). Storage temperature should be between 50°F and 90°F (10°C – 32°C).

- **⚠** Direct sunlight, fluorescent light, or ozone producing electrical equipment can cause the bladder to weather check and dry rot, which appear on the bladder surface as cracks.
- Bladders are to be wrapped per **Figure 21** or laid flat without bending or folding.



Figure 21

Extended storage life (Up to 3 years from the date of shipment):

- Extended life can be achieved by having the bladder charged with 1-4 PSig of nitrogen to its full size. (See **Figure 22**.)
- Heat seal bladder in a 5 mil minimum black polyethylene bag or a 3 mil minimum U.V. resistant bag.
- The air in the plastic bag should be purged using nitrogen prior to sealing.

The bag must then be placed in an appropriate size cardboard box, sealed and kept in a cool and dry place away from direct sunlight, ultraviolet, and fluorescent lights as well as ozone producing electrical equipment. Storage temperature should be between 50°F and 90°F (10°C – 32°C).



Figure 22

How to Determine how Long a Bladder Has Been in Storage

To monitor how long a bladder is kept in storage, the manufacturing date code can be used. The date code can be found on the bladder stem marked: mm/dd/yy.



Figure 23

Recycling & Disposal

Prior to recycling, the accumulator must be made inoperable by drilling through its cylindrical shell. Once inoperable, the accumulator can be recycled by separating the steel parts from the rubber seals and bladder. Recycle rubber and steel parts separately.

Bladder Accumulators can contain residual hydraulic fluid. The hydraulic fluid can be hazardous to the environment. Dispose of the bladder-type accumulator in accordance with the provisions applicable in your country. Dispose of any hydraulic fluid residues according to the respective safety data sheets valid for these hydraulic fluids.



Parker Hannifin Corporation
Accumulator & Cooler Division
10711 N Second Street
Machesney Park, IL 61115
phone 815 636 4100
fax 815 636 4111
www.parker.com/accumulator