



Series D1VW **Directional** **Control Valves** *91 Design*

Catalog HY14-2536/US



**WARNING – USER RESPONSIBILITY**

FAILURE OR IMPROPER SELECTION OR IMPROPER USE OF THE PRODUCTS DESCRIBED HEREIN OR RELATED ITEMS CAN CAUSE DEATH, PERSONAL INJURY AND PROPERTY DAMAGE.

- This document and other information from Parker-Hannifin Corporation, its subsidiaries and authorized distributors provide product or system options for further investigation by users having technical expertise.
- The user, through its own analysis and testing, is solely responsible for making the final selection of the system and components and assuring that all performance, endurance, maintenance, safety and warning requirements of the application are met. The user must analyze all aspects of the application, follow applicable industry standards, and follow the information concerning the product in the current product catalog and in any other materials provided from Parker or its subsidiaries or authorized distributors.
- To the extent that Parker or its subsidiaries or authorized distributors provide component or system options based upon data or specifications provided by the user, the user is responsible for determining that such data and specifications are suitable and sufficient for all applications and reasonably foreseeable uses of the components or systems.

OFFER OF SALE

The items described in this document are hereby offered for sale by Parker-Hannifin Corporation, its subsidiaries or its authorized distributors. This offer and its acceptance are governed by the provisions stated in the detailed "Offer of Sale" elsewhere in this document or available at www.parker.com/hydraulicvalve.

SAFETY GUIDE

For safety information, see Safety Guide SG HY14-1000 at www.parker.com/safety or call 1-800-CParker.

© Copyright 2007, Parker Hannifin Corporation, All Rights Reserved

Cat HY14-2536-frtcvr.indd, dd



Manifold Mounted Directional Control Valves

Introduction.....	3 - 6
Application	3
Operation.....	3
Electrical Connections.....	4
Features	5, 6, 15
Standard Spool Reference Data.....	7
D1VL, D1VA, D1VP, D1VC Reference Data.....	8
Plugs and Connectors	8
Performance Curves.....	9 - 12
D1VW - 30 Watt Coil Reference Data and Performance Curves.....	13
D1VW -10 Watt Coil Reference Data and Performance Curves.....	14
General Description.....	15
Specifications	15
Response Time.....	15
Ordering Information.....	16, 17
Solenoid Ratings and Electrical Specifications.....	18
Dimensions.....	19 - 26
Monitor Switch.....	26
Accessories – Mounting Bolt Kits	27, 28
Installation Information	29
Terms of Sale with Warranty Limitations.....	30
Safety Guide.....	31, 32

Application

Series D1V hydraulic directional control valves are high performance, direct operated 4-way valves. They are available in 2 or 3-position styles. They are manifold mounted valves, which conform to NFPA's D03, CETOP 3 mounting pattern. These valves were designed for industrial and mobile hydraulic applications which require high cycle rates, long life and high efficiency.

Operation

Series D1V directional control valves consist of a 4-chamber style body, and a case hardened sliding spool. The spool is directly shifted by a variety of operators including: solenoid, lever, cam, air or oil pilots.

D1VW Solenoid Operated Plug-In Conduit Box Style

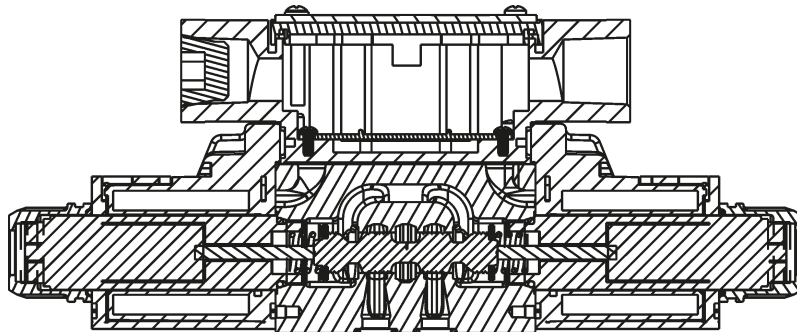

- Easy access mounting bolts.
- Waterproof NEMA 4, IP67.
- No tools required for coil removal.
- 21 standard spool styles available.
- Four electrical connection options.
- Lights included (CSA approval for DC solenoids and lights).
- Easy coil replacement.
- Plug-In design offered with lights & other options.

D1VW Solenoid Operated Hirschmann (DIN) Style

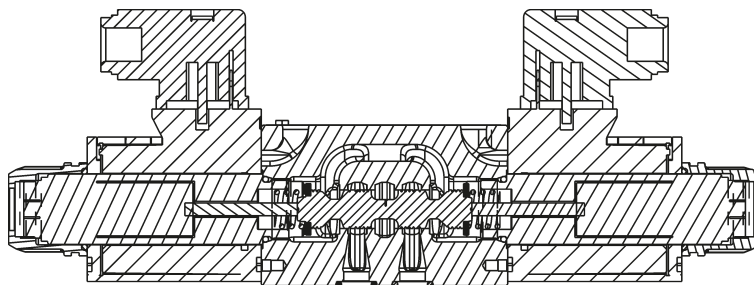

- DIN Style (43650) Hirschmann.
- 21 spool styles available.
- No tools required for coil removal.
- Easy coil replacement.
- AC & DC lights available. (CSA approval for solenoids and lights).

D1VP Oil Pilot Operated

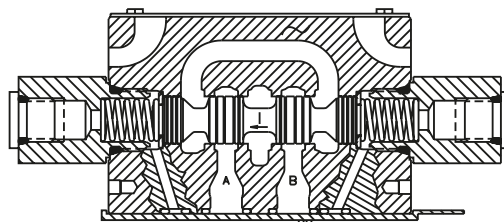

- Subplate pilot or end cap pilot option.
- Pilot pressure: 15.2 Bar (220 PSI) to 207 Bar (3000 PSI).

Electrical Connections

Series D1V valves may be configured in all popular electrical configurations including:

Plug-in Conduit Box	Explosion Proof	Dual Spade (DC only)
DESINA (DC only)	Hirschmann (DIN)	Wire Lead Conduit Box
Deutsch (DC only)	Metri-Pack (DC only)	

D1VW Solenoid Operated Wire Lead Conduit Box Style

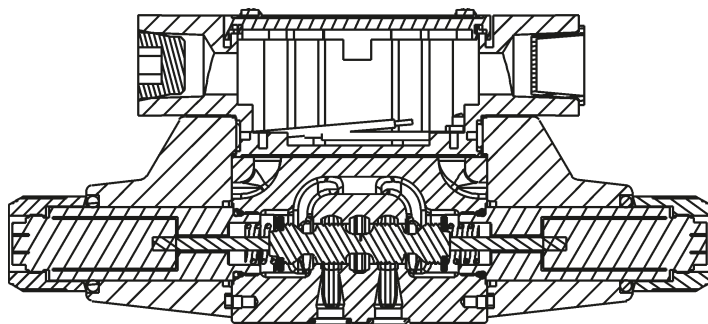

- Easy access mounting bolts.
- Waterproof NEMA 4, IP67.
- No tools required for coil removal.
- 21 spool styles available.
- No lights available

D1VW Solenoid Operated DESINA Style

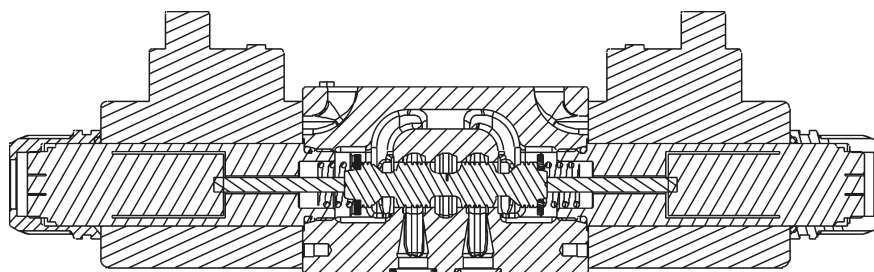

- Surge suppression standard.
- 21 standard spool available.
- No tools required for spool removal.
- Easy coil replacement.
- Wired to DESINA Spec (VDMA).
- Lights included.

D1VW Solenoid Operated Dual Spade Style

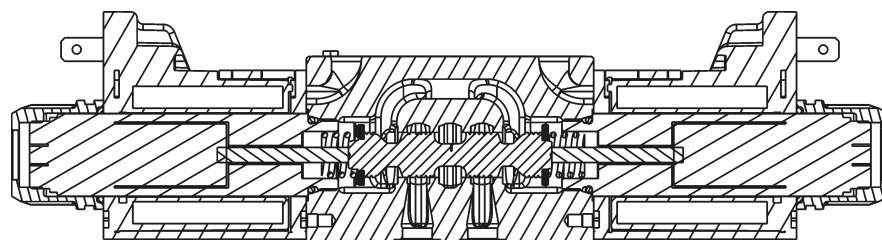

- Dual spade connection (SAE Style 1B).
- Easy coil replacement.
- Surge suppression available.
- 21 standard spool styles available.

Features

- Easy access mounting bolts.
- 345 Bar (5000 PSI) pressure rating.
- Flows to 22 GPM depending on spool.
- Choice of five operator styles.
- Rugged four land spools.
- Low pressure drop.
- Phosphate finished body.
- CSA approved and U.L. recognized available.
- Optional proportional spool available.
- Shows 75 Design (not updated to 91 Design)

D1VL Lever Operated

- Spring return or detent styles available.
- Heavy duty handle design.

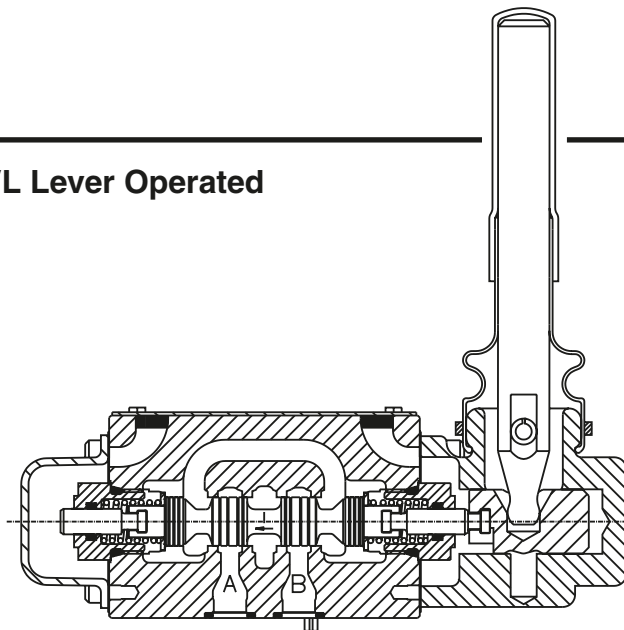
**D1VA Air Operated**

- Low pilot pressure required – 4.1 Bar (60 PSI) minimum.
- Manual overrides standard.

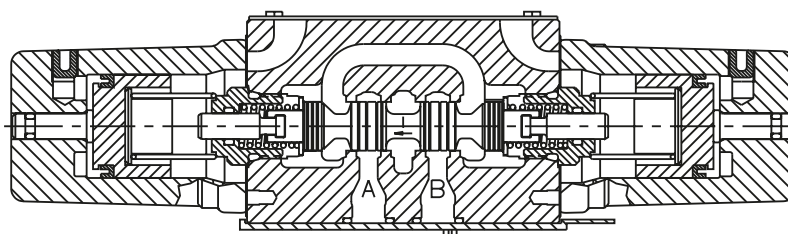
**D1VC Cam Operated**

- Choice of 2 cam roller positions (D1VC and D1VD).
- Two styles available (D1VC and D1VG).
- Short stroke option.
- Stainless steel optional. Contact factory.

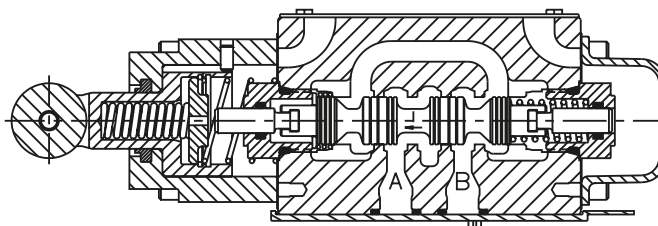

D1VW AC Solenoid Operated Soft Shift

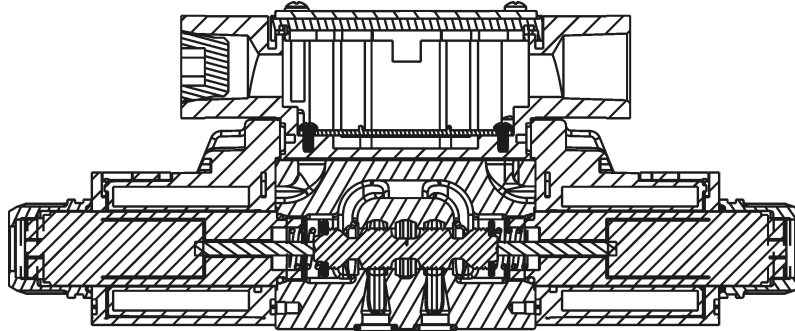

- 4 standard orifice sizes available.
- 19 spool styles available.
- AC Rectified or DC input.

D1VW DC Solenoid Operated Soft Shift

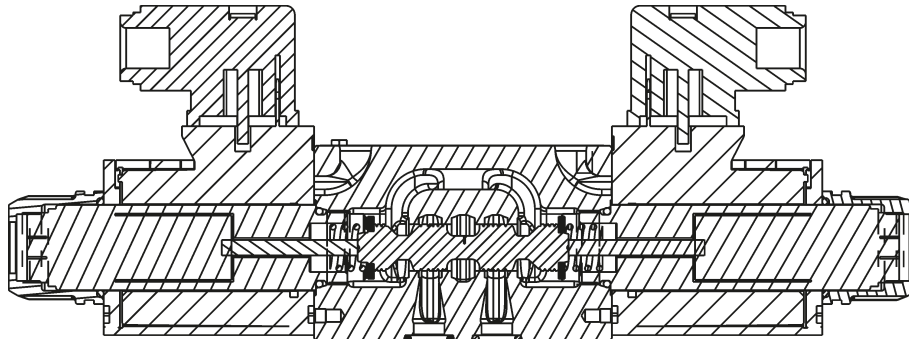

Standard Spool Reference Data

Model	Spool Symbol	Maximum Flow, LPM (GPM) 350 Bar (5000 PSI) w/o Malfunction		
		High Watt DC	Low Watt AC	Low Watt DC
D1V*001		78 (20)	49 (13)	37 (10)
D1V*002		78 (20)	45 (12)	68 (18)
D1V*003		70 (18)	30 (8)	34 (9)
D1V*004		37 (10)	30 (8)	68 (18)
D1V*005		60 (16)	45 (12)	45 (12)
D1V*006		79 (21)	49 (13)	52 (14)
D1V*007		45 (12)	18 (5)	18 (5)
D1V*008		49 (13)	45 (12)	37 (10)
D1V*009		58 (15)	45 (12)	45 (12)
D1V*010		13 (4)	11 (3)	15 (4)
D1V*011		58 (16)	30 (8)	37 (10)
D1V*014		45 (12)	18 (5)	18 (5)
D1V*015		79 (21)	30 (8)	34 (9)
D1V*016		60 (16)	45 (12)	52 (14)
D1V*020		78 (20)	45 (12)	75 (20)
D1V*026		37 (10)	11 (3)	7 (2)
D1V*030		70 (18)	18 (5)	75 (20)
D1V*081		32 (9)	26 (7)	30 (8)
D1V*082		32 (9)	26 (7)	34 (9)

Center or De-energized position is indicated by P, A, B & T port notation.

D1VL, D1VA, D1VP, D1VC Reference Data

Model	Spool Symbol	Maximum Flow, LPM (GPM) 350 Bar (5000 PSI) w/o Malfunction	Model	Spool Symbol	Maximum Flow, LPM (GPM) 350 Bar (5000 PSI) w/o Malfunction
D1V*1		83 (22)	D1V*20 #		53 (14)
D1V*2		83 (22)	D1V*26 #		11 (3)
D1V*4		45 (12)	D1V*30 #		19 (5)
D1V*8		45 (12)	D1V*81		30 (8)
D1V*9		57 (15)	D1V*82		30 (8)

Center or De-energized position is indicated by A, B, P & T port notation.
 # D1VP only.

Manaplug – Electrical Mini Plug

- EP336-30 3 Pin Plug
- EP316-30 5 Pin Plug (Double Solenoid)
- EP31A-30 5 Pin Plug (Single Solenoid)

Desina – 12mm Connector

5004109

Monitor Switch Connector

1301903-N

Manaplug – Electrical Micro Plug

- EP337-30 3 Pin Plug
- EP317-30 5 Pin Plug (Double Solenoid)
- EP31B-30 5 Pin Plug (Single Solenoid)

Electrical Cords – Mini Plug

- EC 3 Conductor, 6 ft.
- EC3 3 Conductor, 3 ft.
- EC12 3 Conductor, 12 ft.
- EC5 5 Conductor, 6 ft.
- EC53 5 Conductor, 3 ft.
- EC512 5 Conductor, 12 ft.

Hirschmann – Female Connector

- 692915 Gray (Solenoid A)
- 692914 Black (Solenoid B)

Quantity Required		
A,C,D	B,E,F	H,K,M
1	–	1
1	1	–

Hirschmann – Female Connector-Rectified (48-240 VAC)

- 1301053 Gray (Solenoid A)
- 1301054 Black (Solenoid B)

1	–	1
1	1	–

Hirschmann – Female Connector-Rectified w/Lights (100-240 VAC)

1300712

2	1	1
---	---	---

Hirschmann – Female Connector w/Lights (Note Voltages)

- 694935 6-48 VAC or VDC
- 694936 48-120 VDC, 100-240 VAC

2	1	1
2	1	1

D1V Shift Limits, DC & AC Rectified 30 Watt

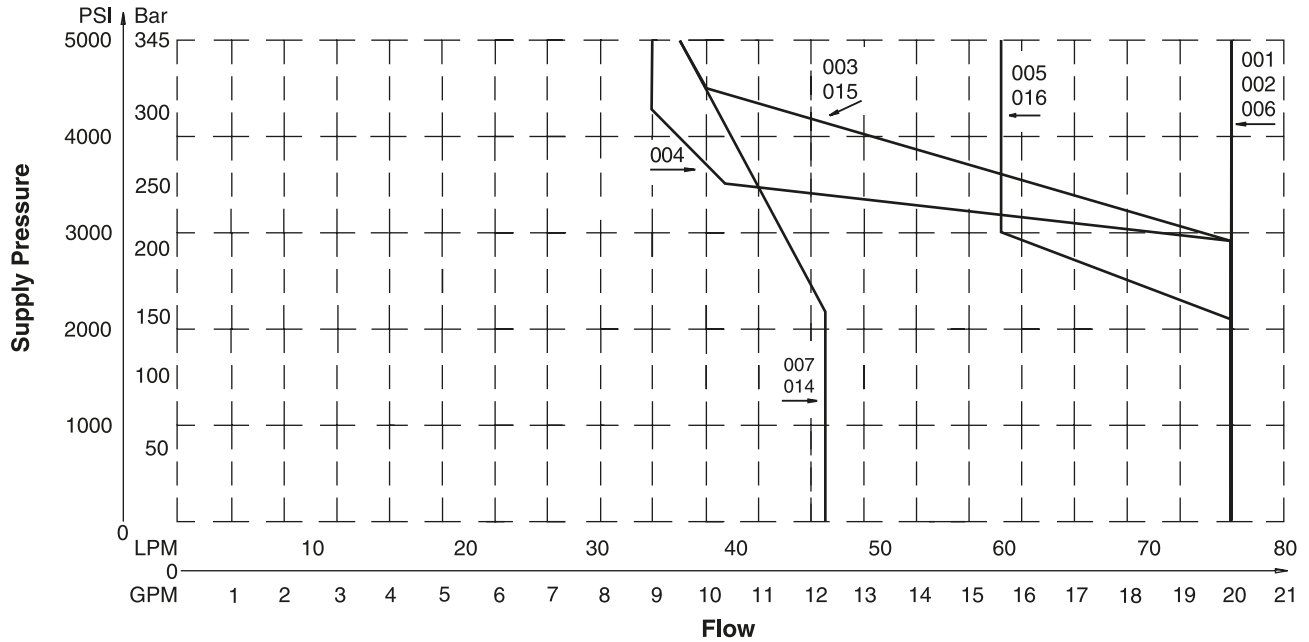

Example:

Determine the maximum allowable flow of a Series D1V valve (#004 spool) at 138 Bar (2000 PSI) supply pressure. Locate the curve marked "004". At 138 Bar (2000 PSI) supply pressure, the maximum flow is 57 LPM (15 GPM). At 207 Bar (3000 PSI), the flow is 49 LPM (13 GPM).

Important Notes for Switching Limit Charts

1. For F & M style valves, reduce flow to 70% of that shown.
2. Shift limits charted for equal flow A and B ports. Unequal A and B port flows may reduce shift limits.
3. These charts do not show explosion proof performance. Consult factory for explosion proof duty.
4. Blocking A or B ports will reduce flow by 70%.

D1VW***L Shift Limits**

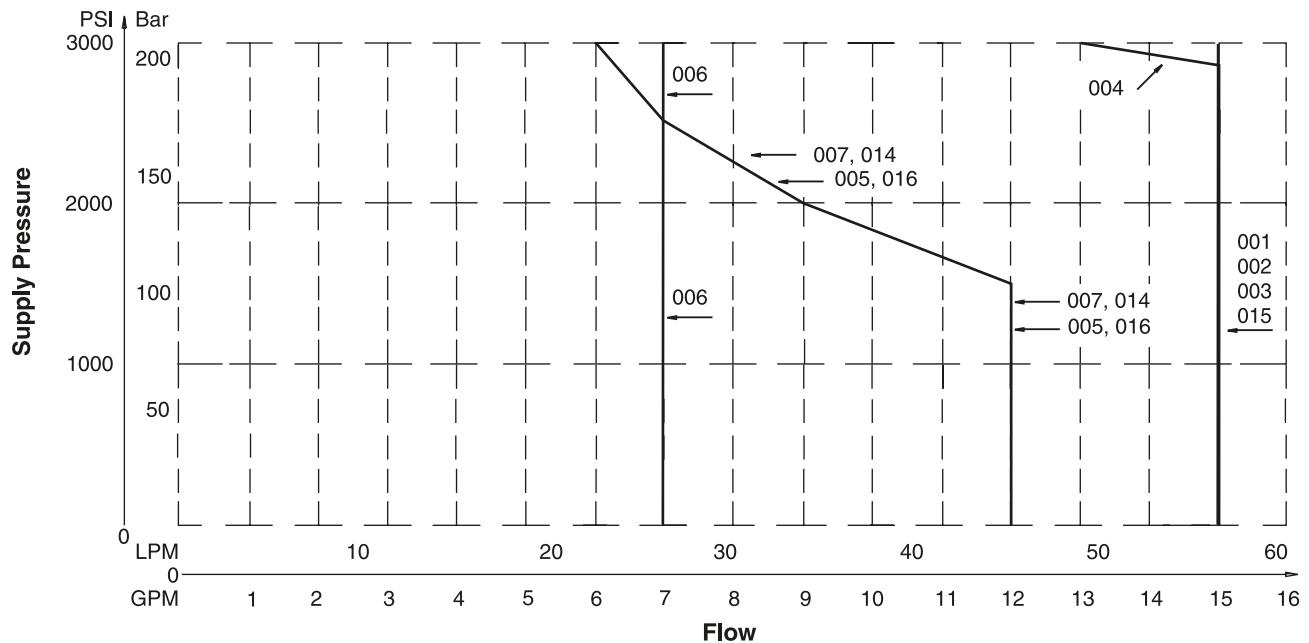

D1V Shift Limits, DC & AC Rectified 30 Watt

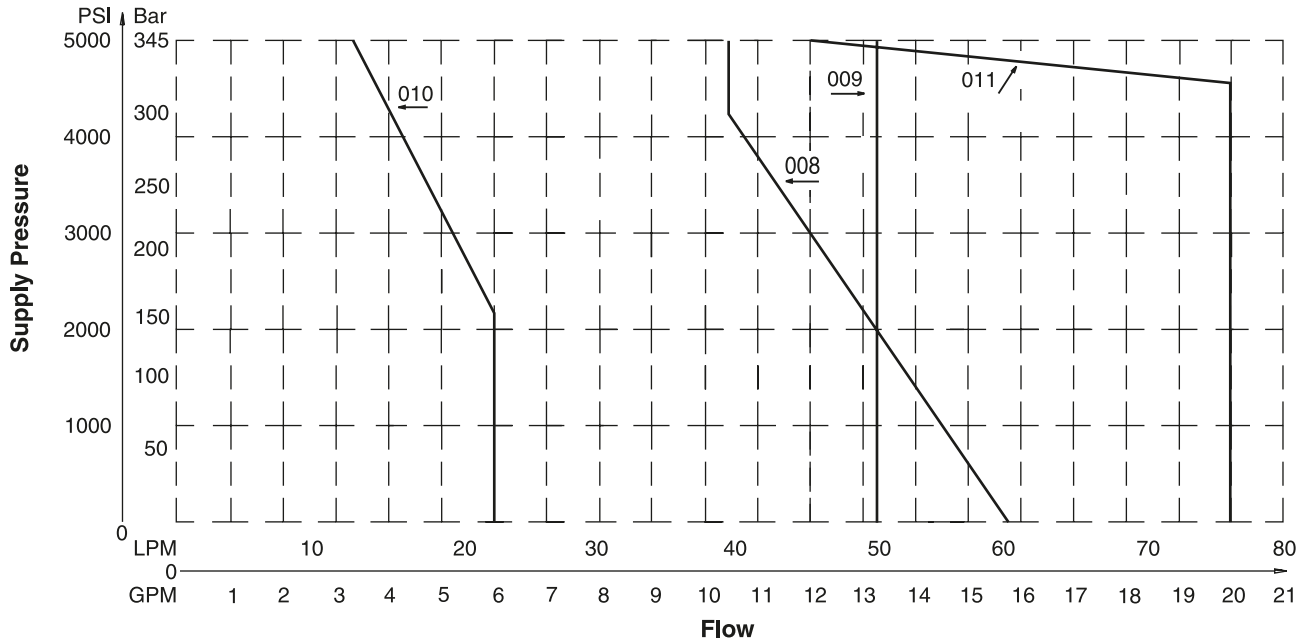

Example:

Determine the maximum allowable flow of a Series D1V valve (#008 spool) at 83 Bar (1200 PSI) supply pressure. Locate the curve marked "008". At 83 Bar (1200 PSI) supply pressure, the maximum flow is 57 LPM (15 GPM). At 207 Bar (3000 PSI), the flow is 19 LPM (5 GPM).

Important Notes for Switching Limit Charts

1. For F & M style valves, reduce flow to 70% of that shown.
2. Shift limits charted for equal flow A and B ports. Unequal A and B port flows may reduce shift limits.
3. These charts do not show explosion proof performance. Consult factory for explosion proof duty.
4. Blocking A or B ports will reduce flow by 70%.

D1VW***L Shift Limits**

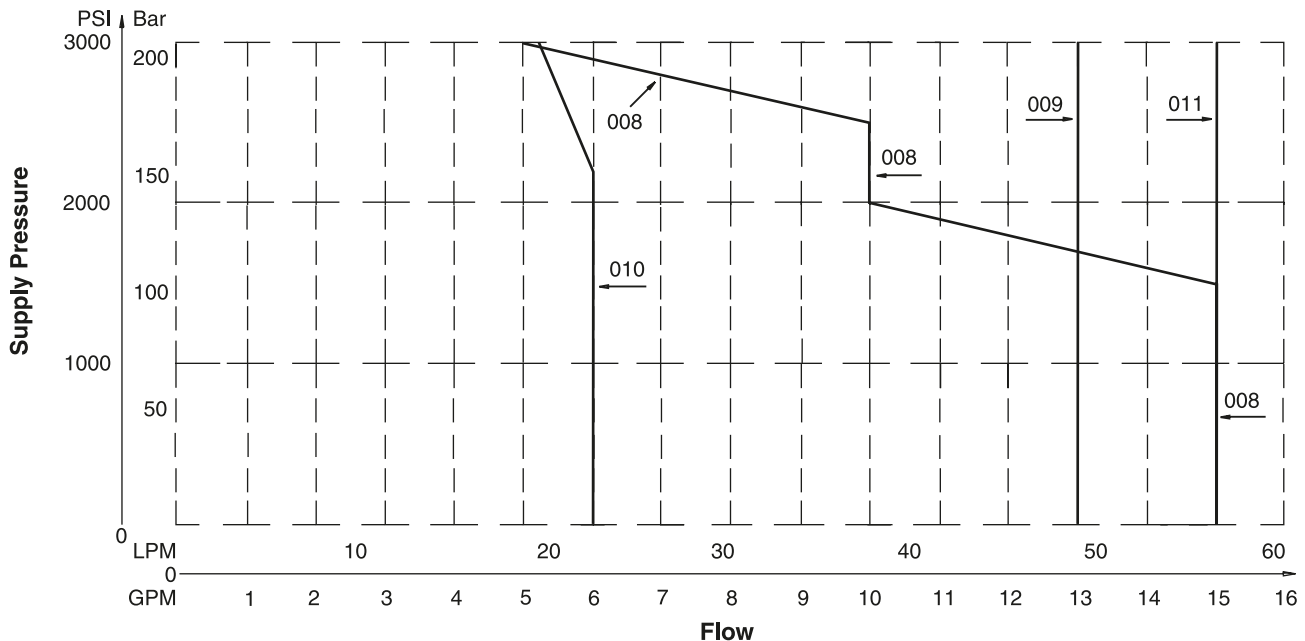

D1V Shift Limits, DC & AC Rectified 30 Watt

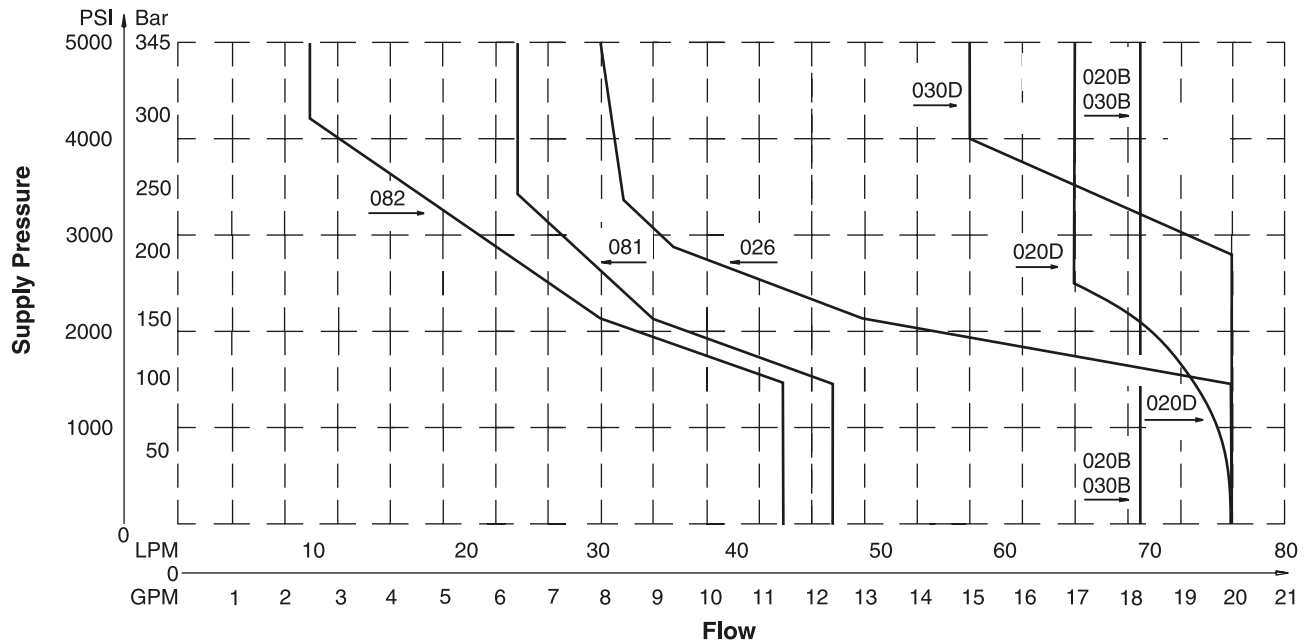

Example:

Determine the maximum allowable flow of a Series D1V valve (#081 spool) at 83 Bar (1200 PSI) supply pressure. Locate the curve marked "081". At 83 Bar (1200 PSI) supply pressure, the maximum flow is 42 LPM (11 GPM). At 138 Bar (2000 PSI), the flow is 42 LPM (11 GPM).

Important Notes for Switching Limit Charts

1. For F & M style valves, reduce flow to 70% of that shown.
2. Shift limits charted for equal flow A and B ports. Unequal A and B port flows may reduce shift limits.
3. These charts do not show explosion proof performance. Consult factory for explosion proof duty.
4. Blocking A or B ports will reduce flow by 70%.

D1VW***L Shift Limits**

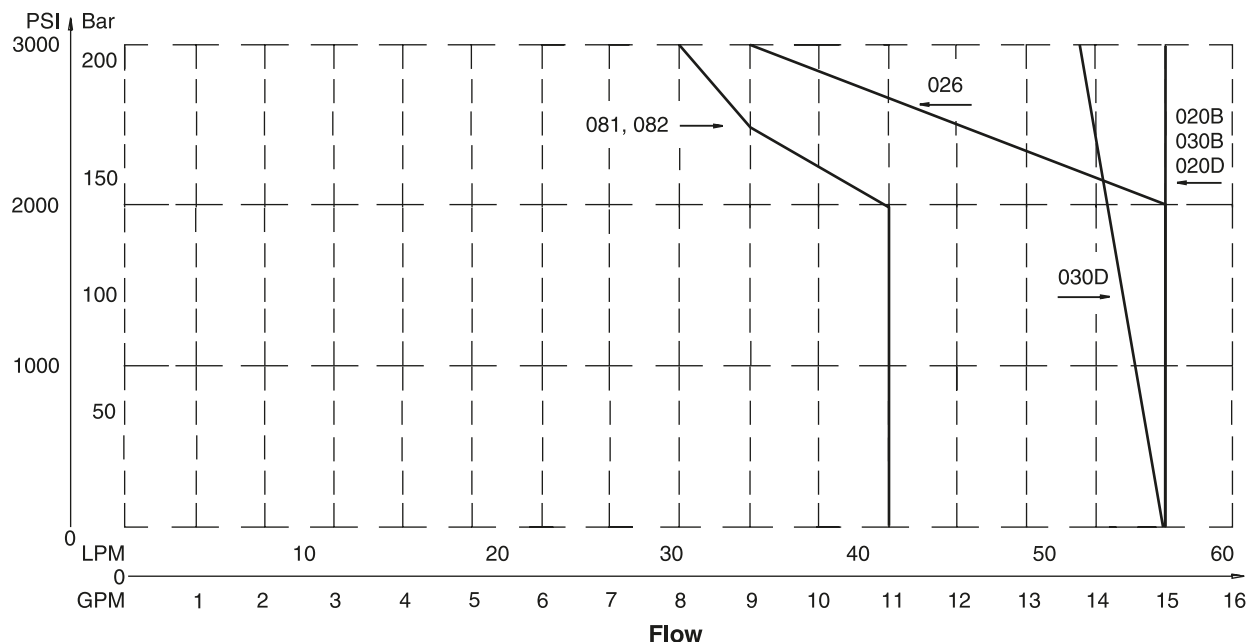

D1VW***F Shift Limits, AC**

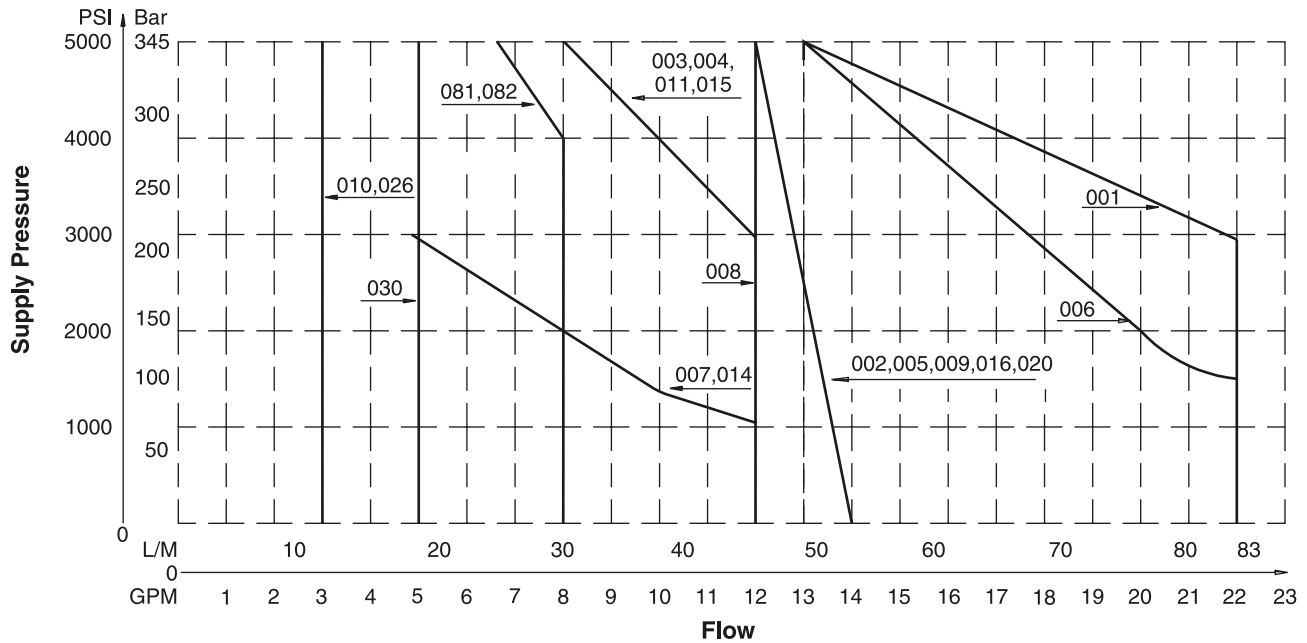

Example:

Determine the maximum allowable flow of a Series D1V valve (#009 spool) at 83 Bar (1200 PSI) supply pressure. Locate the curve marked "009". At 83 Bar (1200 PSI) supply pressure, the maximum flow is 75 LPM (20 GPM). At 207 Bar (3000 PSI), the flow is 68 LPM (18 GPM).

Important Notes for Switching Limit Charts

1. For F & M style valves, reduce flow to 70% of that shown.
2. Shift limits charted for equal flow A and B ports. Unequal A and B port flows may reduce shift limits.
3. These charts do not show explosion proof performance. Consult factory for explosion proof duty.
4. Blocking A or B ports will reduce flow by 70%.

Soft Shift Limit Curves

DC Power Supply

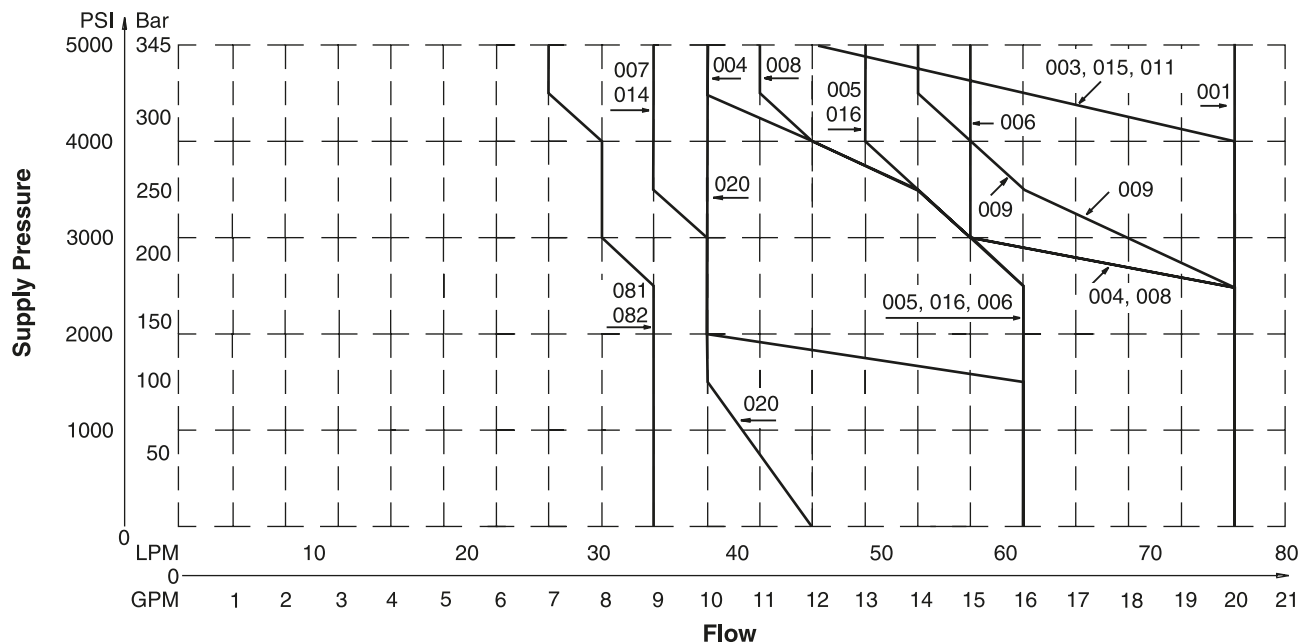

Pressure Drop vs. Flow, High Watt

The table to the right provides the flow vs. pressure drop curve reference for standard and high performance D1V Series valves by spool type.

The chart below demonstrates graphically the pressure drop characteristics of the standard D1VW****F and the high performance D1V. The low watt coil and other design features of the standard D1VW****F accommodate a maximum flow of 50 LPM (13 GPM) at 345 Bar (5000 PSI).

D1VW Pressure Drop Reference Chart – 30 Watt Coil

Spool No.	Curve Number										
	Shifted				Center Condition						
	P-A	P-B	B-T	A-T	(P-T)	(B-A)	(A-B)	(P-A)	(P-B)	(A-T)	(B-T)
001	3	3	2	2	—	—	—	—	—	—	—
002	2	2	1	1	2	1	1	1	1	1	1
003	2	2	1	1	—	—	—	—	—	1	—
004	2	2	1	1	—	—	—	—	—	2	2
005	2	3	1	1	—	—	—	5	—	—	—
006	2	2	1	1	—	6	6	6	6	—	—
007	2	3	1	1	4	—	1	—	—	—	—
008	5	5	5	5	5	—	—	—	—	—	—
009	4	4	4	4	4	—	—	—	—	—	—
010	3	3	—	—	—	—	—	—	—	—	—
011	3	3	1	1	—	—	—	—	—	8	8
014	3	2	1	1	4	1	—	—	—	—	—
015	2	2	1	1	—	—	—	—	—	—	1
016	3	2	1	1	—	—	—	—	5	—	—
020	4	4	2	2	—	—	—	—	—	—	—
026	4	4	—	—	—	—	—	—	—	—	—
030	2	2	1	1	—	—	—	—	—	—	—
081	7	7	8	8	—	—	—	—	—	—	—
082	7	7	8	8	—	—	—	—	—	—	—

Viscosity Correction Factor

Viscosity (SSU)	75	150	200	250	300	350	400	Curves were generated using 100 SSU hydraulic oil. For any other viscosity, pressure drop will change per chart. Pressure drops charted for equal flow A and B ports. Unequal A and B port flows may decrease shift limits.
% of ΔP (Approx.)	93	111	119	126	132	137	141	

Performance Curves – 30 Watt Coil

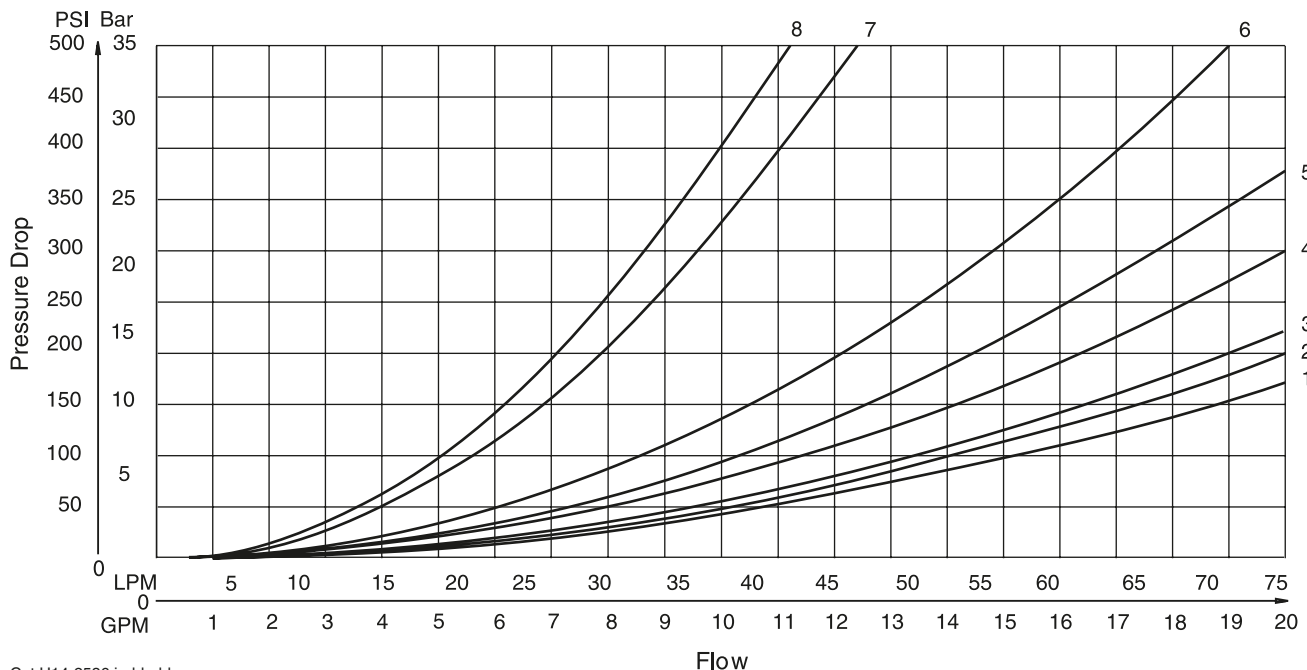

Cat H14-2536.indd, dd

Pressure Drop vs. Flow, Low Watt

The table to the right provides the flow vs. pressure drop curve reference for low and 8 watt D1V Series valves by spool type.

The chart below demonstrates graphically the pressure drop characteristics of the standard D1VW****L and the high performance D1V. The low watt coil and other design features of the standard D1VW****L accommodate a maximum flow of 50 LPM (13 GPM) at 345 Bar (5000 PSI).

D1VW Pressure Drop Reference Chart – 10 Watt Coil

Spool No.	Curve Number											
	Shifted				Center Condition							
	P-A	P-B	B-T	A-T	(P-T)	(B-A)	(A-B)	(P-A)	(P-B)	(A-T)	(B-T)	
001	3	3	2	2	—	—	—	—	—	—	—	
002	2	2	1	1	2	2	2	2	2	1	1	
003	3	3	2	1	—	—	—	—	—	4	—	
004	3	3	1	1	—	—	—	—	—	6	6	
005	3	3	1	1	—	—	—	7	—	—	—	
006	3	3	1	1	—	8	8	7	7	—	—	
007	3	3	1	1	5	—	4	—	—	—	1	
008	5	5	6	6	7	—	—	—	—	—	—	
009	6	6	6	6	5	—	—	—	—	—	—	
010	4	4	—	—	—	—	—	—	—	—	—	
011	3	3	1	1	—	—	—	—	—	11	11	
014	3	3	1	1	4	—	—	2	—	1	—	
015	3	3	1	2	—	—	—	—	—	—	4	
016	3	3	1	1	—	—	—	—	7	—	—	
020	7	7	4	4	—	—	—	—	—	—	—	
026	6	6	—	—	—	—	—	—	—	—	—	
030	2	2	1	1	—	—	—	—	—	—	—	
081	9	9	10	10	—	—	—	—	—	—	—	
082	10	10	10	10	—	—	—	—	—	—	—	

Viscosity Correction Factor

Viscosity (SSU)	75	150	200	250	300	350	400
% of ΔP (Approx.)	93	111	119	126	132	137	141

Curves were generated using 100 SSU hydraulic oil.
 For any other viscosity, pressure drop will change per chart.

Performance Curves – 10 Watt Coil

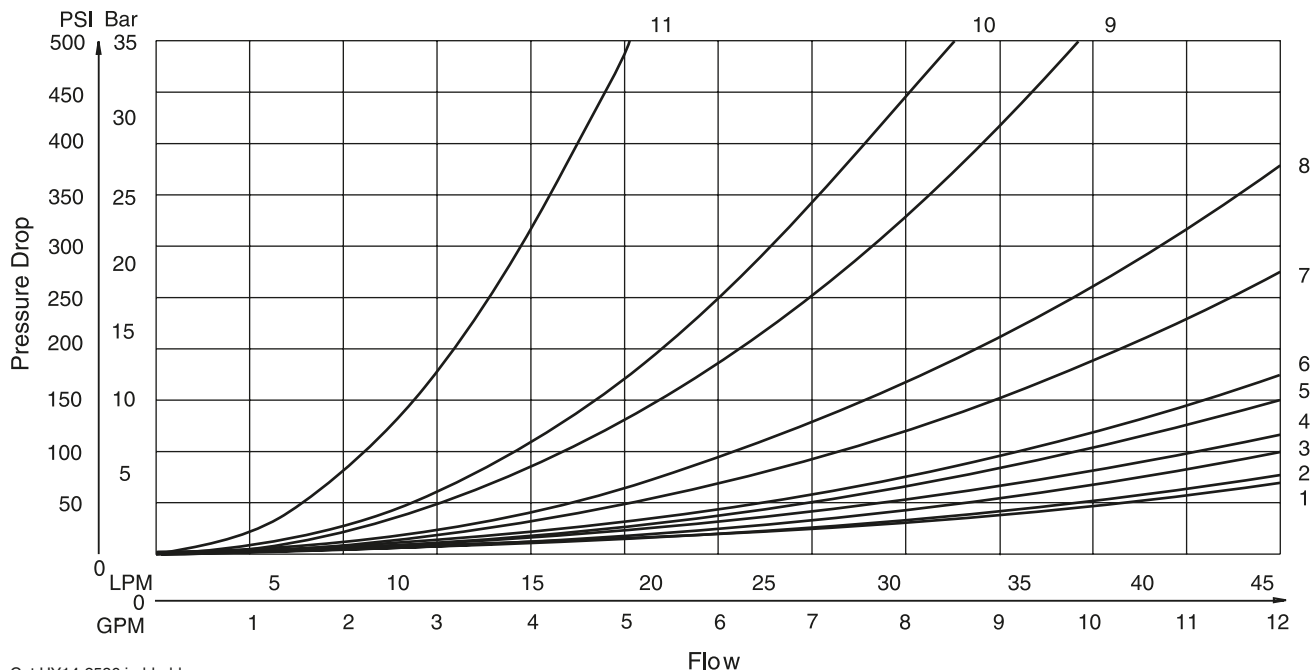

General Description

Series D1VW directional control valves are high performance, 4-chamber, direct operated, wet armature solenoid controlled, 3 or 4-way valves. They are available in 2 or 3-position and conform to NFPA's D03, CETOP 3 mounting patterns.

Features

- Soft shift available.
- 21 standard spool styles available (for other spools – Consult Factory).
- Proportional spools.
- DC surge suppression.
- Nine electrical connection options.
- AC & DC lights available (CSA approval for solenoids and lights).
- Internally ground.
- Easy access mounting bolts.
- Waterproof (meets NEMA 4, up to IP67 on some models).
- Explosion proof.
- CSA approvals.

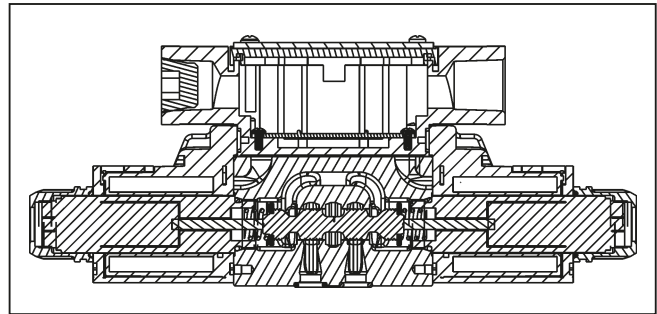
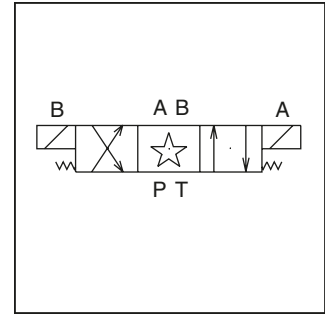
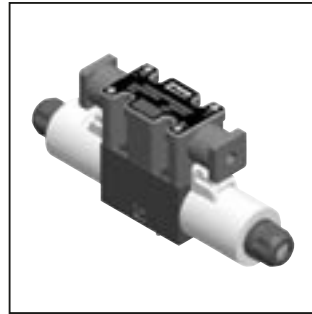

- U.L. recognized available - Contact Division.
- No tools required for coil removal.
- AC rectified coils.

Specifications

Mounting Pattern	NFPA D03, CETOP 3; NG 6	Leakage Rates* 100 SSU @ 49°C (120°F)	Maximum Allowable: 19.7 cc (1.2 Cu. in.) per Minute/Land @ 69 Bar (1000 PSI)* 73.8 cc (4.5 Cu. in.) per Minute/Land @ 207 Bar (3000 PSI)*
Mounting Interface	DIN 24340-A6 ISO 4401-AB-03-4-A CETOP R35H 4.2-4-03, NFPA D03		
Maximum Pressure	P, A, B 345 Bar (5000 PSI) Standard CSA 276 Bar (3750 PSI) Tank: 103 Bar (1500 PSI) AC only 207 Bar (3000 PSI) DC/AC Rectified Standard 207 Bar (3000 PSI) AC Optional CSA 103 Bar (1500 PSI)	*#008 and #009 Spools may exceed these rates. Consult Factory	Typical: 4.9 cc (0.3 Cu. in.) per Minute/Land @ 69 Bar (1000 PSI)* 26.2 cc (1.6 Cu. in.) per Minute/Land @ 345 Bar (5000 PSI)

Response Time

Response time (milliseconds) at 345 Bar (5000 PSI) is 32 LPM (8.5 GPM).

Solenoid Type	Pull-In	Drop-Out
AC	13	20
DC 8 Watt or 10 Watt	61	22
DC 30 Watt	51	21

Soft Shift	Orifice Size	Spool Center Condition					
		Closed		Open		2-Position	
		Energize	De-Energize	Energize	De-Energize	Energize	De-Energize
S2	0.020	125 ms	920 ms	200 ms	275 ms	51 ms	100 ms
S5	0.050	51 ms	675 ms	50 ms	27 ms	51 ms	21 ms

Standard Valves

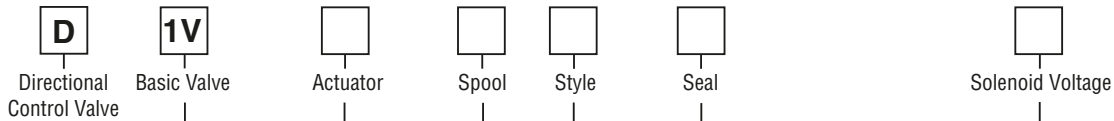

NFPA D03
 CETOP 3
 DIN NG6

Code Description
W* Solenoid, Wet Pin, Screw-in
HW* Reversed Wiring

Code Description
N Nitrile
V Fluorocarbon
E* EPR

Code Description
A** 24/50 VAC
D 120 VDC
G 198 VDC
J 24 VDC
K 12 VDC
L 6 VDC
N*** 220/50 VAC
P*** 110/50 VAC

Code Description
Q** 100/60 VAC
QD 100/60 - 100/50 VAC
R 24/60 VAC
T 240/60 - 220/50 VAC
U 98 VDC
Y 120/60 - 110/50 VAC
Z 250 VDC

* Valve schematic symbols are per NFPA/ANSI standards, providing flow P to A when energizing solenoid A. Note operators reverse sides for #008 and #009 spools. See installation information for details. To configure per DIN standards (A coil over A port, B coil over B port) code valves as D1VHW***.

* Contact HVD for availability.

** High Watt only
 *** Explosion Proof only.

Code	Symbol	Code	Symbol
001		011	
002		014	
003		015	
004		016	
005		020*	
006		026*	
007		030**	
008*, 009**		081	
010		082	

Code	Description	Symbol
B*	Single solenoid, 2 position, spring offset. P to A and B to T in offset position.	
C	Double solenoid, 3 position, spring centered.	
D†	Double solenoid, 2 position, detent.	
E	Single solenoid, 2 position, spring centered. P to B and A to T when energized.	
F‡	Single solenoid, 2 position. Spring offset, energized to center. Position spool spacer on A side. P to A and B to T in spring offset position.	
H*	Single solenoid, 2 position, spring offset. P to B and A to T in offset position.	
K	Single solenoid, 2 position, spring centered. P to A and B to T when energized.	
M‡	Single solenoid, 2 position, spring offset, energized to center position. Spool spacer on B side. P to B and A to T in spring offset position.	

* 008, 020 & 026 spools have closed crossover.
 ** 009 & 030 spool have open crossover.
 See Universal Spool Chart for other spool options.

* 020, 026 and 030 spools only.
 † 020 and 030 spools only.
 ‡ High Watt only.

Bold: Designates Tier I products and options.

Non-Bold: Designates Tier II products and options. These products will have longer lead times.



Standard Valves

<div style="border: 1px solid black; width: 20px; height: 20px; margin: 0 auto;"></div> <p>Solenoid Connection</p>	<div style="border: 1px solid black; width: 20px; height: 20px; margin: 0 auto;"></div> <p>Coil Options</p>	<div style="border: 1px solid black; width: 20px; height: 20px; margin: 0 auto;"></div> <p>Tube Options</p>	<div style="border: 1px solid black; width: 20px; height: 20px; margin: 0 auto;"></div> <p>Manual Override Options</p>	<div style="border: 1px solid black; width: 20px; height: 20px; margin: 0 auto;"></div> <p>Electrical Options</p>	<div style="border: 1px solid black; width: 20px; height: 20px; margin: 0 auto;"></div> <p>Shift Response and Indication</p>	<div style="border: 1px solid black; width: 20px; height: 20px; margin: 0 auto;"></div> <p>Approvals</p>	<div style="border: 1px solid black; width: 20px; height: 20px; margin: 0 auto;"></div> <p>Valve Variations</p>	<div style="border: 1px dashed black; width: 20px; height: 20px; margin: 0 auto;"></div> <p>Design Series</p> <p>NOTE: Not required when ordering.</p>																																																																																																													
<table border="1" style="width: 100%; border-collapse: collapse;"> <thead> <tr> <th style="text-align: left;">Code</th> <th style="text-align: left;">Description</th> </tr> </thead> <tbody> <tr> <td>C††</td> <td>Leadwire Conduit Box</td> </tr> <tr> <td>D††</td> <td>Metric Plug (M12X1), DESINA</td> </tr> <tr> <td>E*</td> <td>Explosion Proof</td> </tr> <tr> <td>G‡</td> <td>Plug-In Conduit Box</td> </tr> <tr> <td>J†*</td> <td>Deutsch (DT06-2S)</td> </tr> <tr> <td>M†*</td> <td>Metri-Pack (150)</td> </tr> <tr> <td>P</td> <td>DIN with Plug</td> </tr> <tr> <td>S†*</td> <td>Double Spade</td> </tr> <tr> <td>W*</td> <td>DIN w/o Plug</td> </tr> </tbody> </table> <p>* Not available with lights. † DC only. †† No variations – See Plug-in. ‡ Must have lights.</p>	Code	Description	C††	Leadwire Conduit Box	D††	Metric Plug (M12X1), DESINA	E*	Explosion Proof	G‡	Plug-In Conduit Box	J†*	Deutsch (DT06-2S)	M†*	Metri-Pack (150)	P	DIN with Plug	S†*	Double Spade	W*	DIN w/o Plug	<table border="1" style="width: 100%; border-collapse: collapse;"> <thead> <tr> <th style="text-align: left;">Code</th> <th style="text-align: left;">Description</th> </tr> </thead> <tbody> <tr> <td>Omit</td> <td>Standard Response</td> </tr> <tr> <td>S2*</td> <td>Soft Shift, 0.020" Orifice</td> </tr> <tr> <td>S5*</td> <td>Soft Shift, 0.050" Orifice</td> </tr> <tr> <td>17**</td> <td>Monitor Switch Direct Op. End Stroke</td> </tr> <tr> <td>18**</td> <td>Monitor Switch Direct Op. Start Stroke</td> </tr> </tbody> </table> <p>* Not available with 8 watt. ** B, E, H & K styles only. Spools 8,9,21,26,81,82 not available. Not CE or CSA approved.</p>	Code	Description	Omit	Standard Response	S2*	Soft Shift, 0.020" Orifice	S5*	Soft Shift, 0.050" Orifice	17**	Monitor Switch Direct Op. End Stroke	18**	Monitor Switch Direct Op. Start Stroke	<table border="1" style="width: 100%; border-collapse: collapse;"> <thead> <tr> <th style="text-align: left;">Code</th> <th style="text-align: left;">Description</th> </tr> </thead> <tbody> <tr> <td>Omit†</td> <td>High Watt</td> </tr> <tr> <td>D</td> <td>Explosion Proof, EEXD ATEX</td> </tr> <tr> <td>E</td> <td>Explosion Proof, EEXME ATEX</td> </tr> <tr> <td>F**</td> <td>Low Watt</td> </tr> <tr> <td>L***</td> <td>8 Watt</td> </tr> <tr> <td>O</td> <td>Explosion Proof, MSHA</td> </tr> <tr> <td>U</td> <td>Explosion Proof, UL/CSA</td> </tr> <tr> <td>X*</td> <td>No Coils</td> </tr> </tbody> </table> <p>* See solenoid voltage code to specify proper tube. ** AC only. *** DC and AC Rectified only. † AC ambient temperature must not exceed 60°C (140°F). Lights, softshift, and other options not available on Explosion proof.</p>	Code	Description	Omit†	High Watt	D	Explosion Proof, EEXD ATEX	E	Explosion Proof, EEXME ATEX	F**	Low Watt	L***	8 Watt	O	Explosion Proof, MSHA	U	Explosion Proof, UL/CSA	X*	No Coils	<table border="1" style="width: 100%; border-collapse: collapse;"> <thead> <tr> <th style="text-align: left;">Code</th> <th style="text-align: left;">Description</th> </tr> </thead> <tbody> <tr> <td>Omit</td> <td>No Options</td> </tr> <tr> <td>J**</td> <td>Diode Surge Suppressor</td> </tr> <tr> <td>Z†</td> <td>Rectified Coil</td> </tr> </tbody> </table> <p>† DC tube standard. ** DIN coil must have plug with lights.</p>	Code	Description	Omit	No Options	J**	Diode Surge Suppressor	Z†	Rectified Coil	<table border="1" style="width: 100%; border-collapse: collapse;"> <thead> <tr> <th style="text-align: left;">Code</th> <th style="text-align: left;">Description</th> </tr> </thead> <tbody> <tr> <td>Omit</td> <td>Standard Valve</td> </tr> <tr> <td>3*†</td> <td>CSA USA (UL429)</td> </tr> <tr> <td>4*</td> <td>CSA Canada</td> </tr> </tbody> </table> <p>* Not available with AC high pressure tube. † B, C, H styles only. J, K, Y, U voltages only. C, G, W sol. connections only.</p>	Code	Description	Omit	Standard Valve	3*†	CSA USA (UL429)	4*	CSA Canada	<table border="1" style="width: 100%; border-collapse: collapse;"> <thead> <tr> <th style="text-align: left;">Code</th> <th style="text-align: left;">Description</th> </tr> </thead> <tbody> <tr> <td>Omit</td> <td>Standard</td> </tr> <tr> <td>T* †</td> <td>No Override</td> </tr> <tr> <td>P*</td> <td>Extended Manual Override w/Body</td> </tr> </tbody> </table> <p>* Manual override options not available on explosion proof or soft shift. † DC/AC rectified only.</p>	Code	Description	Omit	Standard	T* †	No Override	P*	Extended Manual Override w/Body	<table border="1" style="width: 100%; border-collapse: collapse;"> <thead> <tr> <th style="text-align: left;">Code</th> <th style="text-align: left;">Description</th> </tr> </thead> <tbody> <tr> <td>Omit</td> <td>Standard Pressure</td> </tr> <tr> <td></td> <td>103.5 Bar (1500 PSI) AC</td> </tr> <tr> <td></td> <td>207 Bar (3000 PSI) DC</td> </tr> <tr> <td>H*</td> <td>High Pressure, AC only</td> </tr> <tr> <td></td> <td>207 Bar (3000 PSI)</td> </tr> </tbody> </table> <p>* Not available with CSA.</p>	Code	Description	Omit	Standard Pressure		103.5 Bar (1500 PSI) AC		207 Bar (3000 PSI) DC	H*	High Pressure, AC only		207 Bar (3000 PSI)	<table border="1" style="width: 100%; border-collapse: collapse;"> <thead> <tr> <th style="text-align: left;">Code</th> <th style="text-align: left;">Description</th> </tr> </thead> <tbody> <tr> <td>5**</td> <td>Signal Lights</td> </tr> <tr> <td>56*</td> <td>Manplug (Mini) with Lights</td> </tr> <tr> <td>7B*</td> <td>Manplug (Micro) with Lights</td> </tr> <tr> <td>1C*</td> <td>Manplug (Mini) Single Sol. 5-pin, with Lights</td> </tr> <tr> <td>1D*</td> <td>Manplug (Micro) Single Sol. 5-pin, with Lights</td> </tr> <tr> <td>1M*</td> <td>Manplug Opposite of Normal</td> </tr> <tr> <td>4D†</td> <td>Twist & Lock Override (Old 5426, 33 Ford wiring)</td> </tr> <tr> <td>4E†</td> <td>Push Manual Override (Old x5450)</td> </tr> <tr> <td>4F</td> <td>Heavy Duty Detent</td> </tr> <tr> <td>1P</td> <td>Painted Body</td> </tr> <tr> <td>7Y*</td> <td>4-pin M12x1 Manplug, special wiring with lights (Old B755)</td> </tr> </tbody> </table> <p>* Plug-in Conduit Box ** Plug-in, DIN, or Desina only † DC/AC Rectified only. Not available with soft shift.</p>	Code	Description	5**	Signal Lights	56*	Manplug (Mini) with Lights	7B*	Manplug (Micro) with Lights	1C*	Manplug (Mini) Single Sol. 5-pin, with Lights	1D*	Manplug (Micro) Single Sol. 5-pin, with Lights	1M*	Manplug Opposite of Normal	4D†	Twist & Lock Override (Old 5426, 33 Ford wiring)	4E†	Push Manual Override (Old x5450)	4F	Heavy Duty Detent	1P	Painted Body	7Y*	4-pin M12x1 Manplug, special wiring with lights (Old B755)
Code	Description																																																																																																																				
C††	Leadwire Conduit Box																																																																																																																				
D††	Metric Plug (M12X1), DESINA																																																																																																																				
E*	Explosion Proof																																																																																																																				
G‡	Plug-In Conduit Box																																																																																																																				
J†*	Deutsch (DT06-2S)																																																																																																																				
M†*	Metri-Pack (150)																																																																																																																				
P	DIN with Plug																																																																																																																				
S†*	Double Spade																																																																																																																				
W*	DIN w/o Plug																																																																																																																				
Code	Description																																																																																																																				
Omit	Standard Response																																																																																																																				
S2*	Soft Shift, 0.020" Orifice																																																																																																																				
S5*	Soft Shift, 0.050" Orifice																																																																																																																				
17**	Monitor Switch Direct Op. End Stroke																																																																																																																				
18**	Monitor Switch Direct Op. Start Stroke																																																																																																																				
Code	Description																																																																																																																				
Omit†	High Watt																																																																																																																				
D	Explosion Proof, EEXD ATEX																																																																																																																				
E	Explosion Proof, EEXME ATEX																																																																																																																				
F**	Low Watt																																																																																																																				
L***	8 Watt																																																																																																																				
O	Explosion Proof, MSHA																																																																																																																				
U	Explosion Proof, UL/CSA																																																																																																																				
X*	No Coils																																																																																																																				
Code	Description																																																																																																																				
Omit	No Options																																																																																																																				
J**	Diode Surge Suppressor																																																																																																																				
Z†	Rectified Coil																																																																																																																				
Code	Description																																																																																																																				
Omit	Standard Valve																																																																																																																				
3*†	CSA USA (UL429)																																																																																																																				
4*	CSA Canada																																																																																																																				
Code	Description																																																																																																																				
Omit	Standard																																																																																																																				
T* †	No Override																																																																																																																				
P*	Extended Manual Override w/Body																																																																																																																				
Code	Description																																																																																																																				
Omit	Standard Pressure																																																																																																																				
	103.5 Bar (1500 PSI) AC																																																																																																																				
	207 Bar (3000 PSI) DC																																																																																																																				
H*	High Pressure, AC only																																																																																																																				
	207 Bar (3000 PSI)																																																																																																																				
Code	Description																																																																																																																				
5**	Signal Lights																																																																																																																				
56*	Manplug (Mini) with Lights																																																																																																																				
7B*	Manplug (Micro) with Lights																																																																																																																				
1C*	Manplug (Mini) Single Sol. 5-pin, with Lights																																																																																																																				
1D*	Manplug (Micro) Single Sol. 5-pin, with Lights																																																																																																																				
1M*	Manplug Opposite of Normal																																																																																																																				
4D†	Twist & Lock Override (Old 5426, 33 Ford wiring)																																																																																																																				
4E†	Push Manual Override (Old x5450)																																																																																																																				
4F	Heavy Duty Detent																																																																																																																				
1P	Painted Body																																																																																																																				
7Y*	4-pin M12x1 Manplug, special wiring with lights (Old B755)																																																																																																																				
<p>Valve Weight:</p> <p>Single Solenoid 1.36 kg (3.0 lbs.) Double Solenoid 1.6 kg (3.5 lbs.)</p> <p>Standard Bolt Kit: BK209 Metric Bolt Kit: BKM209</p>																																																																																																																					

Bold: Designates Tier I products and options.

Non-Bold: Designates Tier II products and options. These products will have longer lead times.

Solenoid Ratings

Insulation System	Class F
Allowable Deviation from rated voltage	-15% to +10% for DC and AC rectified coils -5% to +5% for AC Coils
Armature	Wet pin type
CSA File Number	LR60407
Environmental Capability	DC Solenoids meet NEMA 4 and IP67 when properly wired and installed. Contact HVD for AC coil applications.

Explosion Proof Solenoid Ratings*

UL & CSA (EU)	Class I, Div 1 & 2, Groups C & D Class II, Div 1 & 2, Groups E, F & G As defined by the NEC
MSHA (EO)	Complies with 30CFR, Part 18
ATEX (ED)	Complies with ATEX requirements for: Exd, Group IIB; EN50014: 1999+ Amds. 1 & 2, EN50018: 2000

* Allowable Voltage Deviation ±10%.
 Note that Explosion Proof AC coils are single frequency only.

Code		Voltage	In Rush Amps Amperage	In Rush Amps D1VW VA	Holding Amps D1VW @ 3MM	Watts D1VW	Resistance D1VW
Voltage Code	Power Code						
D	L	120 VDC	N/A	N/A	0.09 Amps	10 W	1584.00 ohms
			N/A	N/A	0.26 Amps	30 W	528.00 ohms
G		198 VDC	N/A	N/A	0.15 Amps	30 W	1306.80 ohms
J	L	24 VDC	N/A	N/A	0.44 Amps	10 W	51.89 ohms
			N/A	N/A	1.32 Amps	30 W	17.27 ohms
K	L	12 VDC	N/A	N/A	0.88 Amps	10 W	12.97 ohms
			N/A	N/A	2.64 Amps	30 W	4.32 ohms
L	L	6 VDC	N/A	N/A	1.67 Amps	10 W	3.59 ohms
			N/A	N/A	5.00 Amps	30 W	1.20 ohms
Q	F	100 VAC / 60 Hz	1.70 Amps	170 VA	0.56 Amps	24 W	26.0 ohms
QD	F	100 VAC / 60 Hz	1.35 Amps	135 VA	0.41 Amps	18 W	31.2 ohms
QD	F	100 VAC / 50 Hz	1.50 Amps	150 VA	0.57 Amps	24 W	31.2 ohms
R	F	24/60 VAC, Low Watt	6.67 Amps	160 VA	2.20 Amps	23 W	1.52 ohms
T	F	240/60 VAC, Low Watt	0.70 Amps	168 VA	0.22 Amps	21 W	145.00 ohms
T	F	220/50 VAC, Low Watt	0.75 Amps	165 VA	0.26 Amps	23 W	145.00 ohms
U		98 VDC	N/A	N/A	0.10 Amps	10 W	960.00 ohms
Y	F	120/60 VAC, Low Watt	1.40 Amps	168 VA	0.42 Amps	21 W	36.50 ohms
Y	F	110/50 VAC, Low Watt	1.50 Amps	165 VA	0.50 Amps	23 W	36.50 ohms
Z	L	250 VDC	N/A	N/A	0.04 Amps	10 W	6875.00 ohms
			N/A	N/A	0.13 Amps	30 W	1889.64 ohms
Explosion Proof Solenoids							
R		24/60 VAC	7.63 Amps	183 VA	2.85 Amps	27 W	1.99 ohms
T		240/60 VAC	0.76 Amps	183 VA	0.29 Amps	27 W	1.34 ohms
N		220/50 VAC	0.77 Amps	169 VA	0.31 Amps	27 W	1.38 ohms
Y		120/60 VAC	1.60 Amps	192 VA	0.58 Amps	27 W	33.50 ohms
P		110/50 VAC	1.47 Amps	162 VA	0.57 Amps	27 W	34.70 ohms
Q		100/60 VAC	1.90 Amps	192 VA	0.70 Amps	27 W	38.60 ohms
K		12 VDC	N/A	N/A	2.75 Amps	33 W	4.36 ohms
J		24 VDC	N/A	N/A	1.38 Amps	33 W	17.33 ohms
D		120 VDC	N/A	N/A	0.28 Amps	33 W	420.92 ohms
Z		250 VDC	N/A	N/A	0.13 Amps	33 W	1952.66 ohms

Inch equivalents for millimeter dimensions are shown in (**)

**DC Plug-In Conduit Box Connector,
with Lights, Double Solenoid**

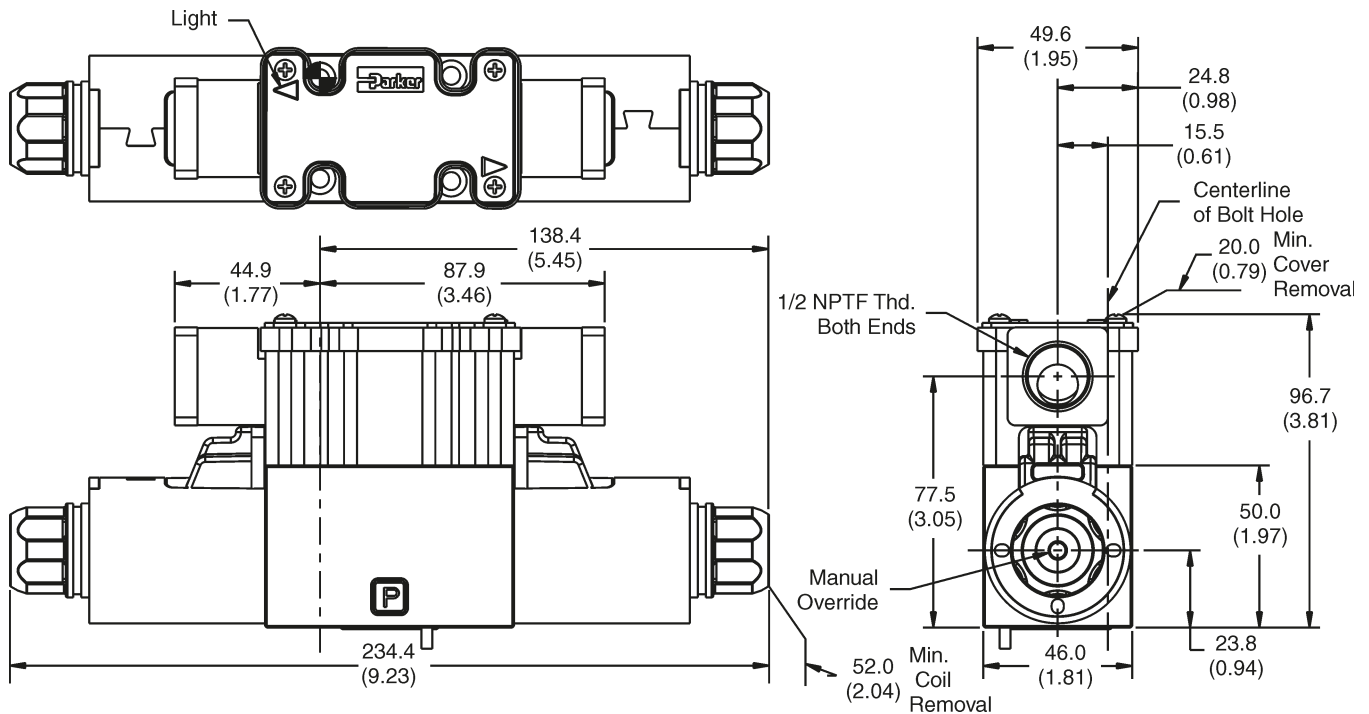

Note: 22.0 mm (0.87") from bottom of bolt hole counterbore to bottom of valve.

**DC Plug-In or Leadwire Conduit Box Connector,
with or without Lights, Single Solenoid**

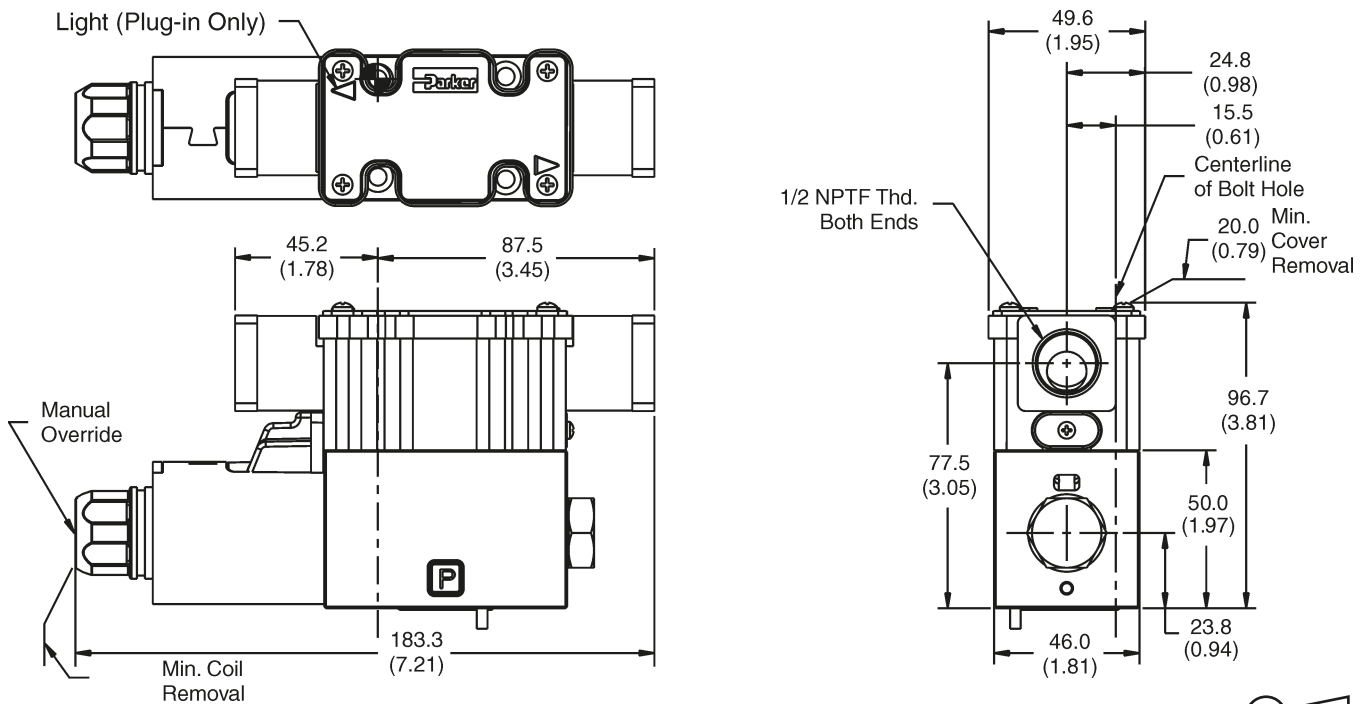

Note: 22.0 mm (0.87") from bottom of bolt hole counterbore to bottom of valve.

Inch equivalents for millimeter dimensions are shown in (**)

DC DIN with Plug Connector, Double Solenoid

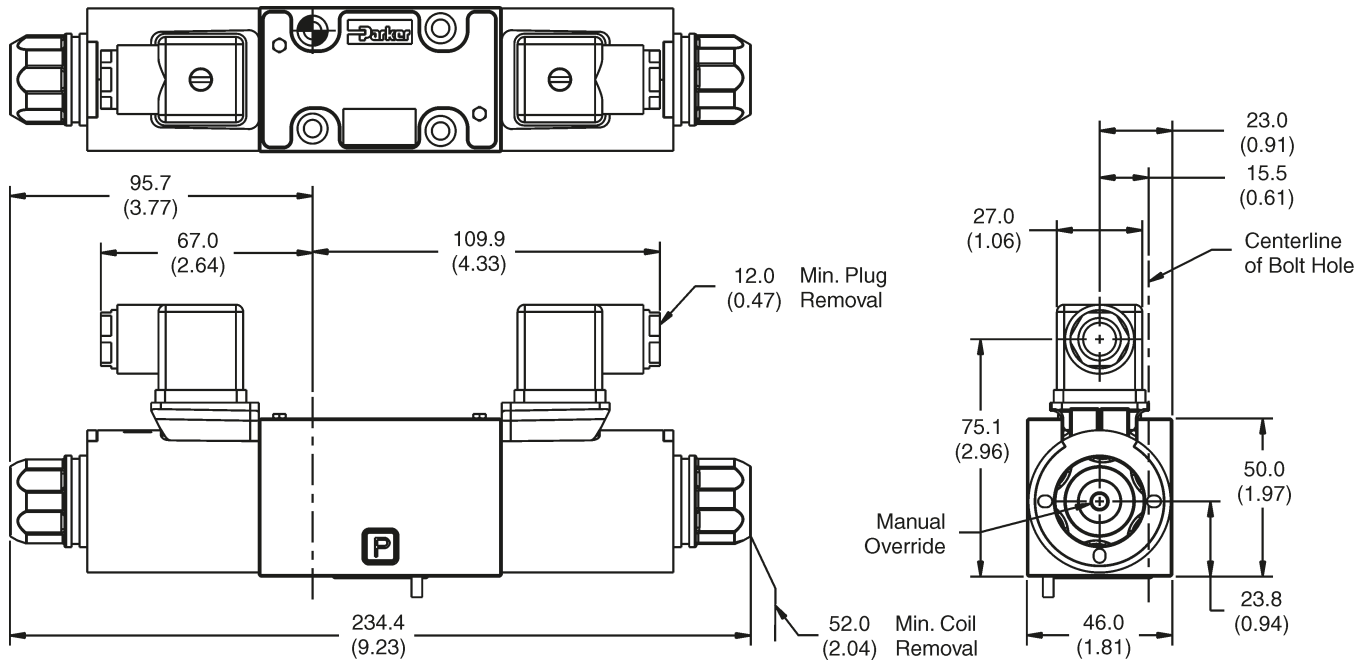

Note: 22.0 mm (0.87") from bottom of bolt hole counterbore to bottom of valve.

DC DIN Connector, Single Solenoid

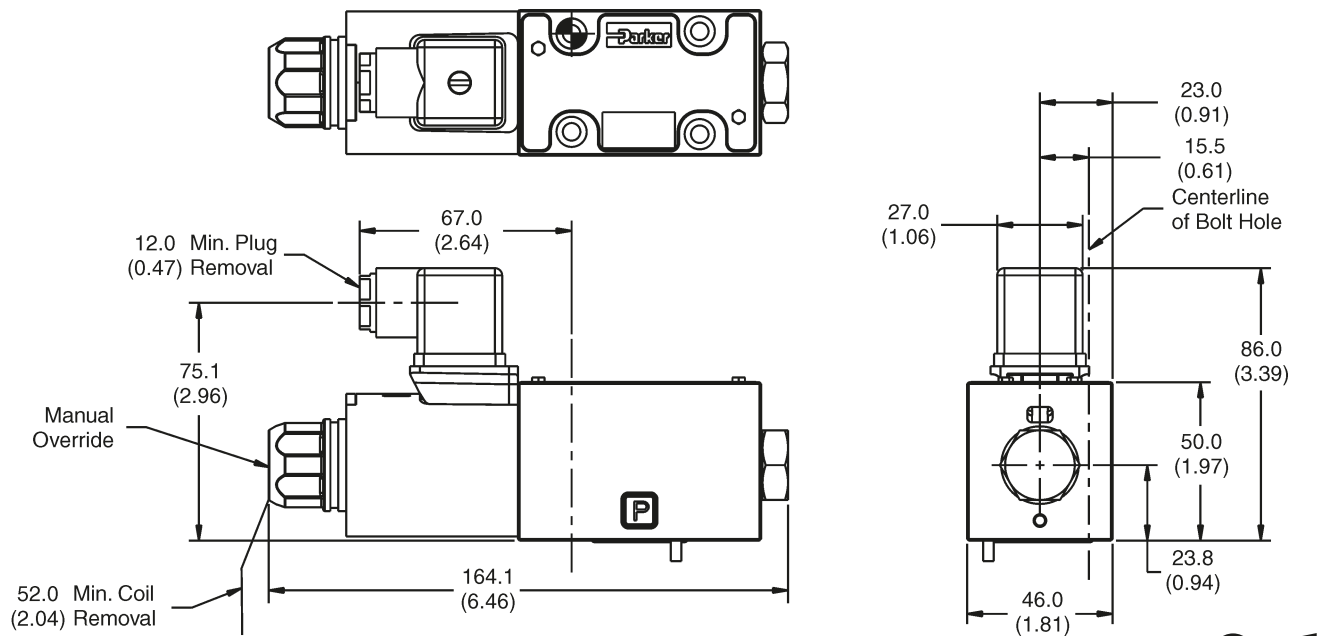

Note: 22.0 mm (0.87") from bottom of bolt hole counterbore to bottom of valve.

Inch equivalents for millimeter dimensions are shown in (**)

**AC Leadwire Conduit Box Connector,
without Lights, Double Solenoid**

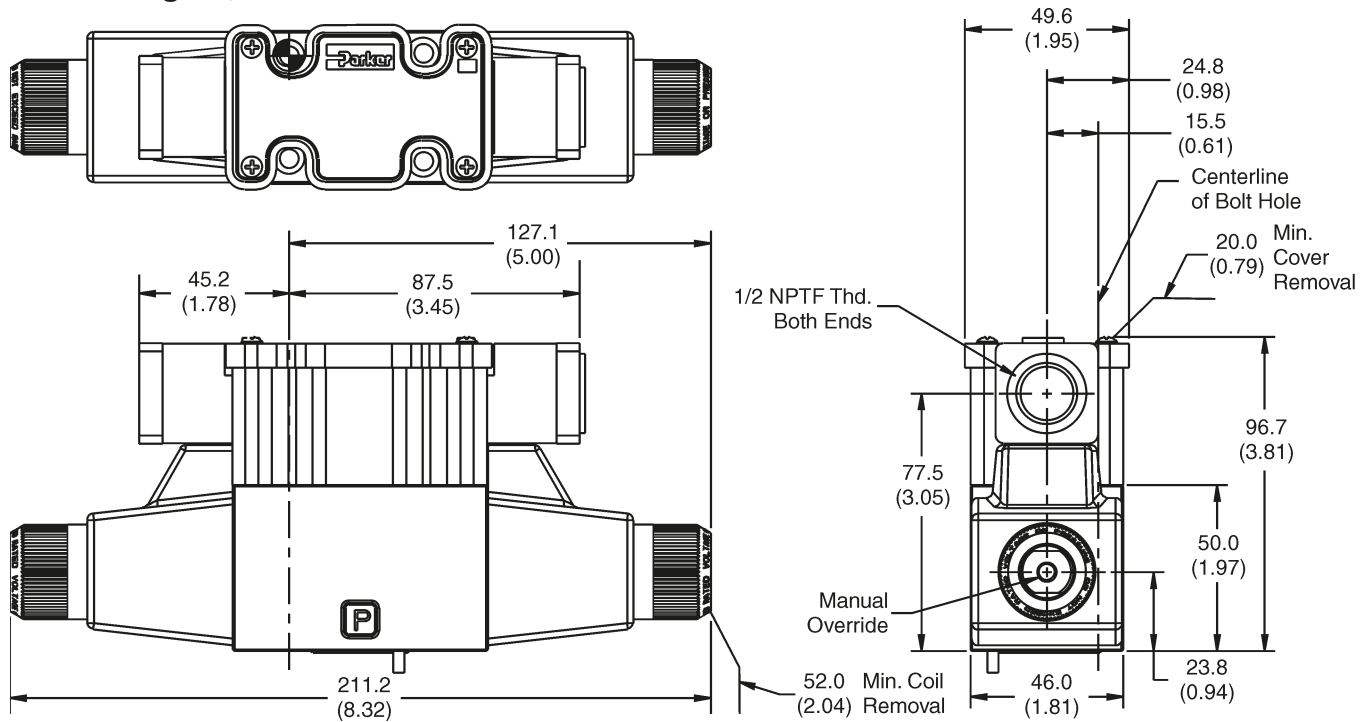

Note: 22.0 mm (0.87") from bottom of bolt hole counterbore to bottom of valve.

**AC Leadwire Conduit Box Connector,
without Lights, Single Solenoid**

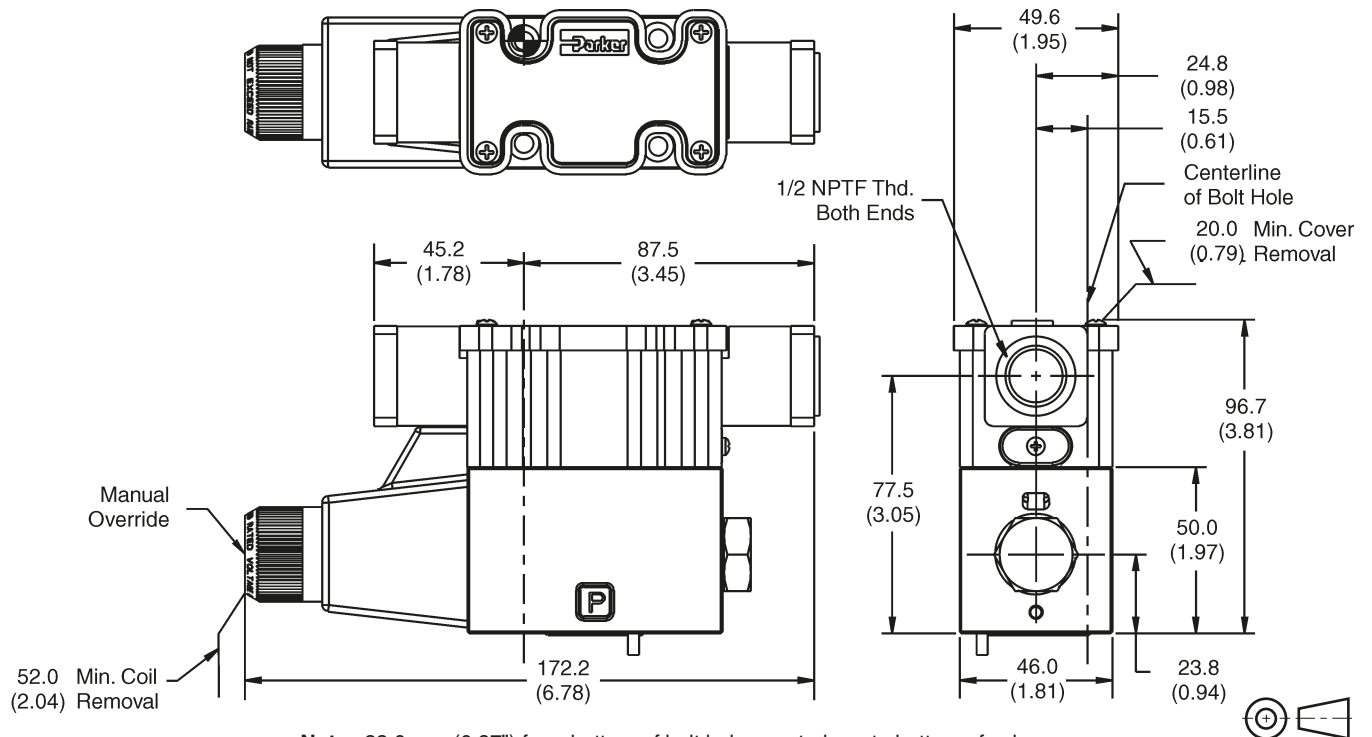

Note: 22.0 mm (0.87") from bottom of bolt hole counterbore to bottom of valve.

Inch equivalents for millimeter dimensions are shown in (**)

AC Plug-in or Leadwire Conduit Box Connector, with or without Lights, Double Solenoid

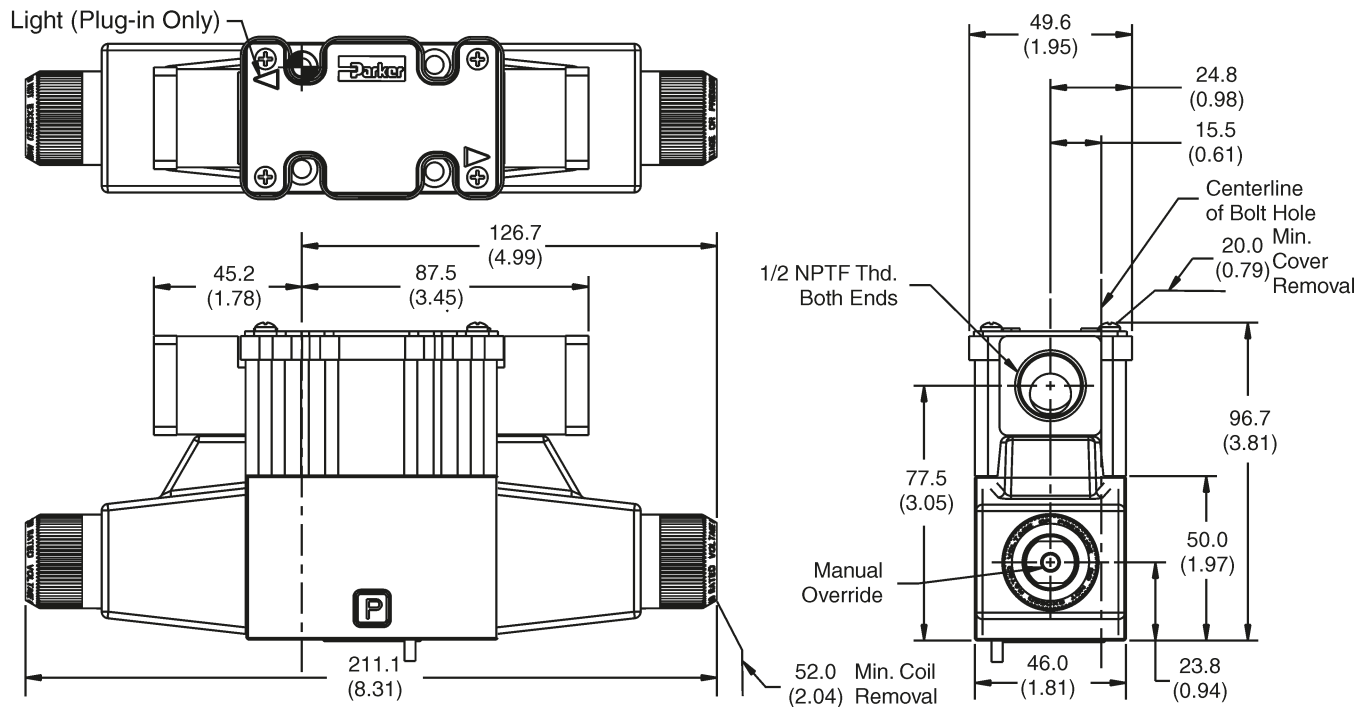

Note: 22.0 mm (0.87") from bottom of bolt hole counterbore to bottom of valve.

DC Plug-in or Leadwire Conduit Box Connector, with or without Lights and Extended Override Tubes, Double Solenoid

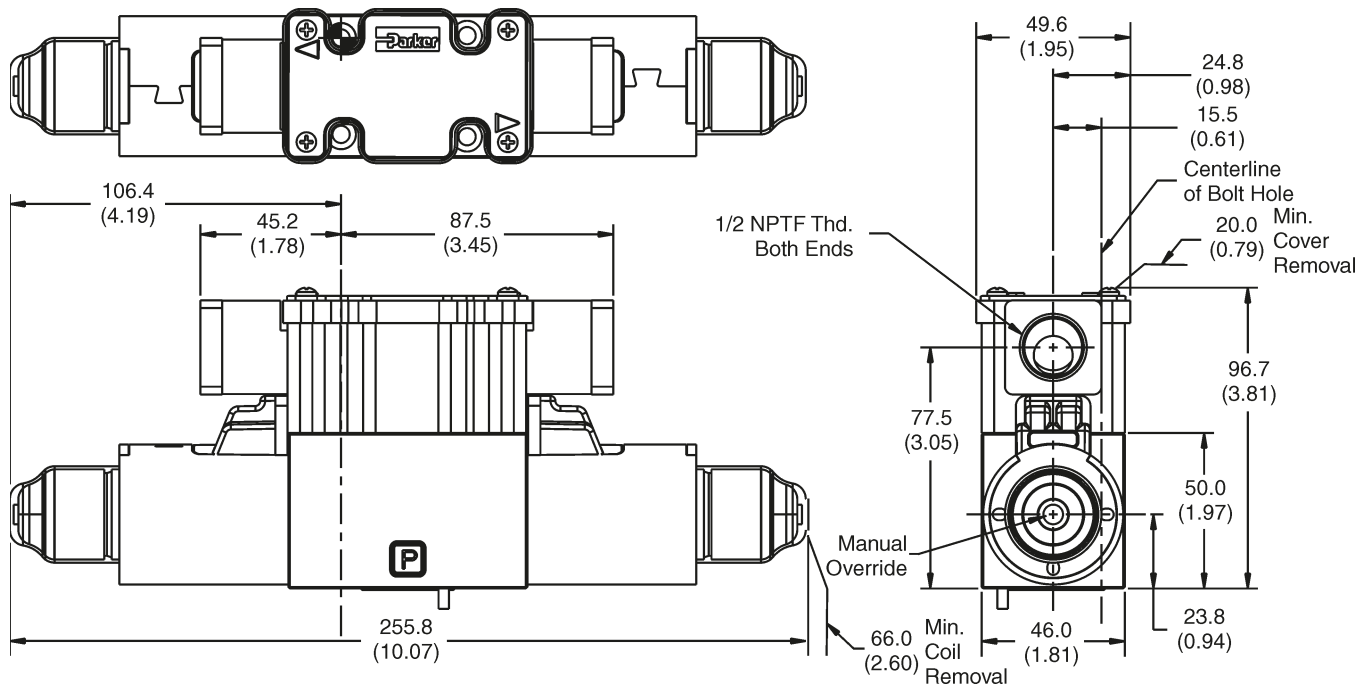

Note: 22.0 mm (0.87") from bottom of bolt hole counterbore to bottom of valve.

Inch equivalents for millimeter dimensions are shown in (**)

DC Deutsch Connector, Double Solenoid

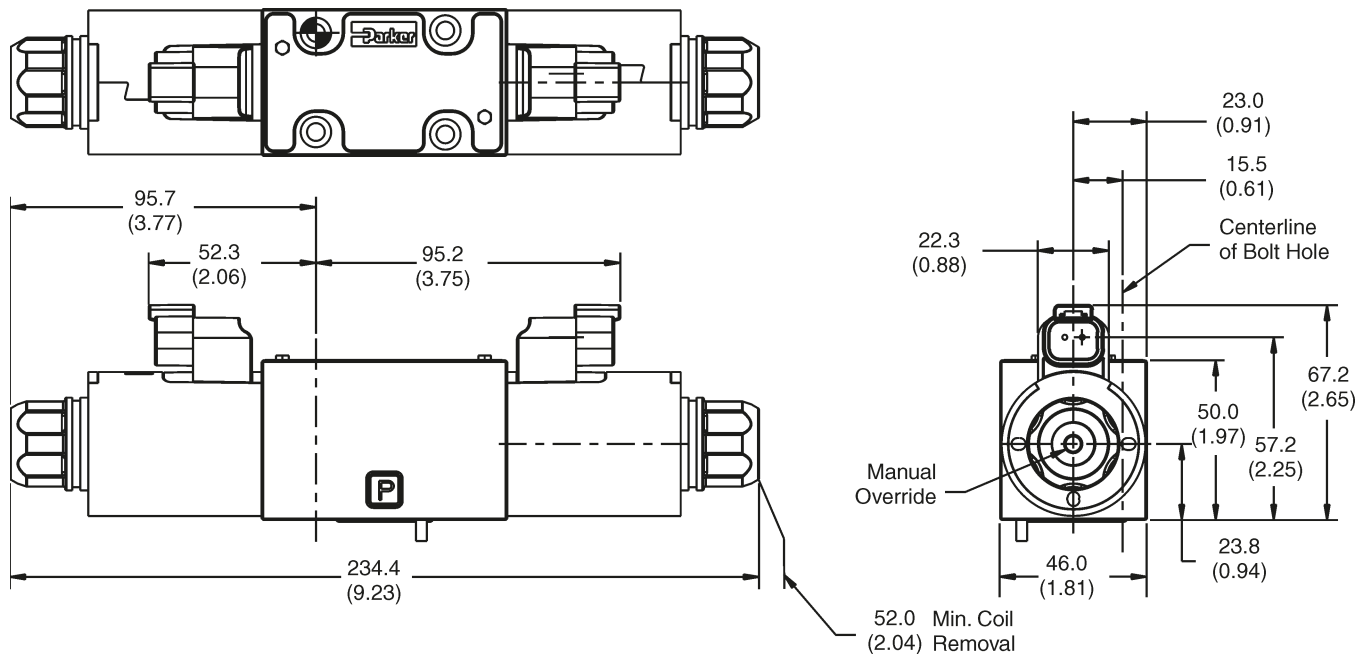

Note: 22.0 mm (0.87") from bottom of bolt hole counterbore to bottom of valve.

DC Deutsch Connector, Single Solenoid

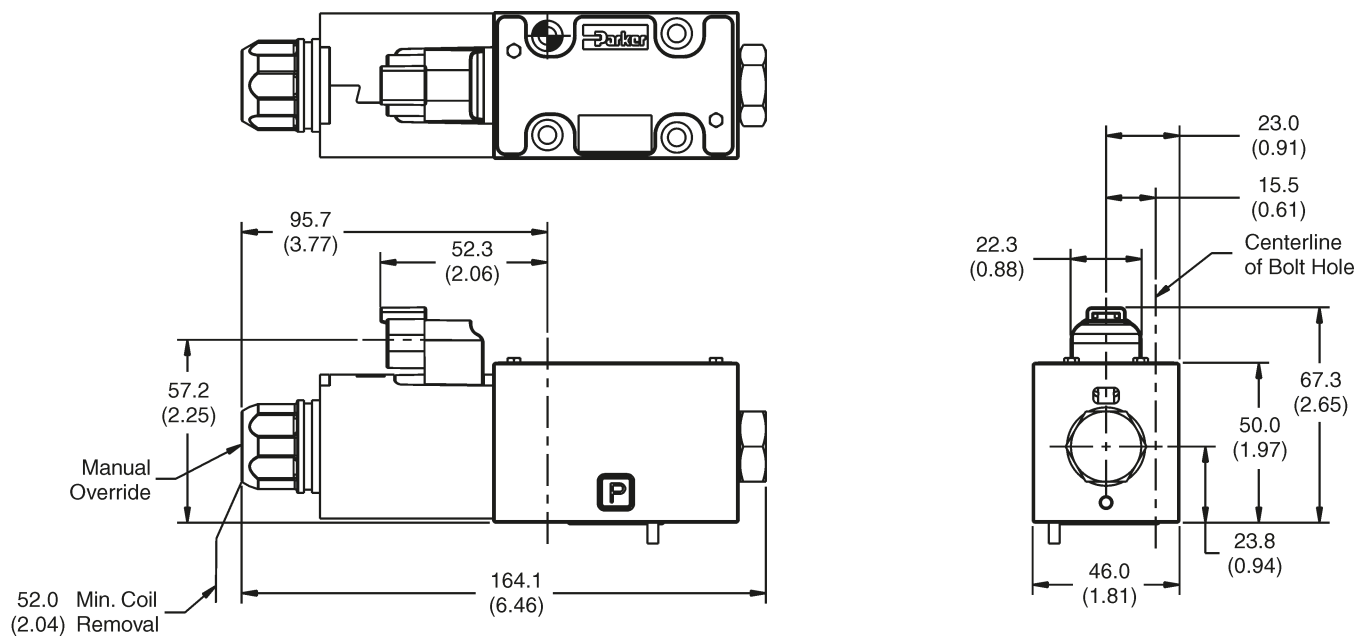

Note: 22.0 mm (0.87") from bottom of bolt hole counterbore to bottom of valve.

Inch equivalents for millimeter dimensions are shown in (**)

DC Desina Connector, Double Solenoid

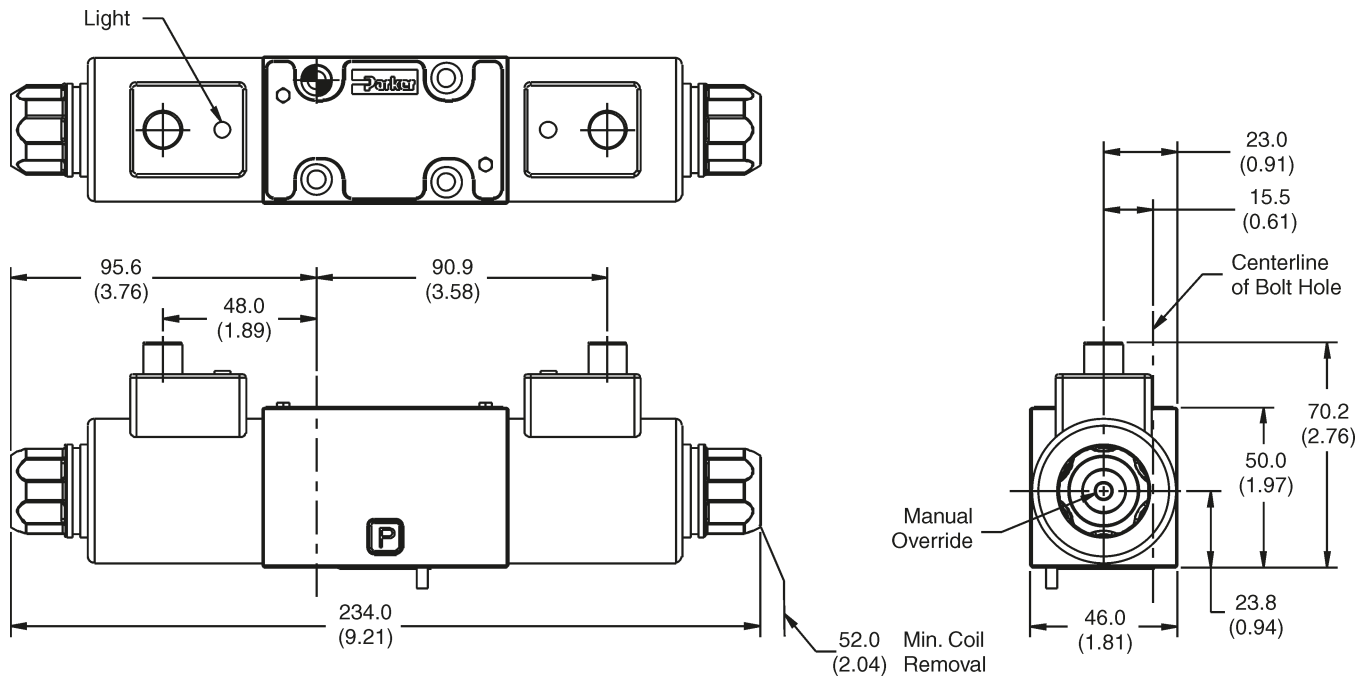

Note: 22.0 mm (0.87") from bottom of bolt hole counterbore to bottom of valve.

DC Desina Connector, Single Solenoid

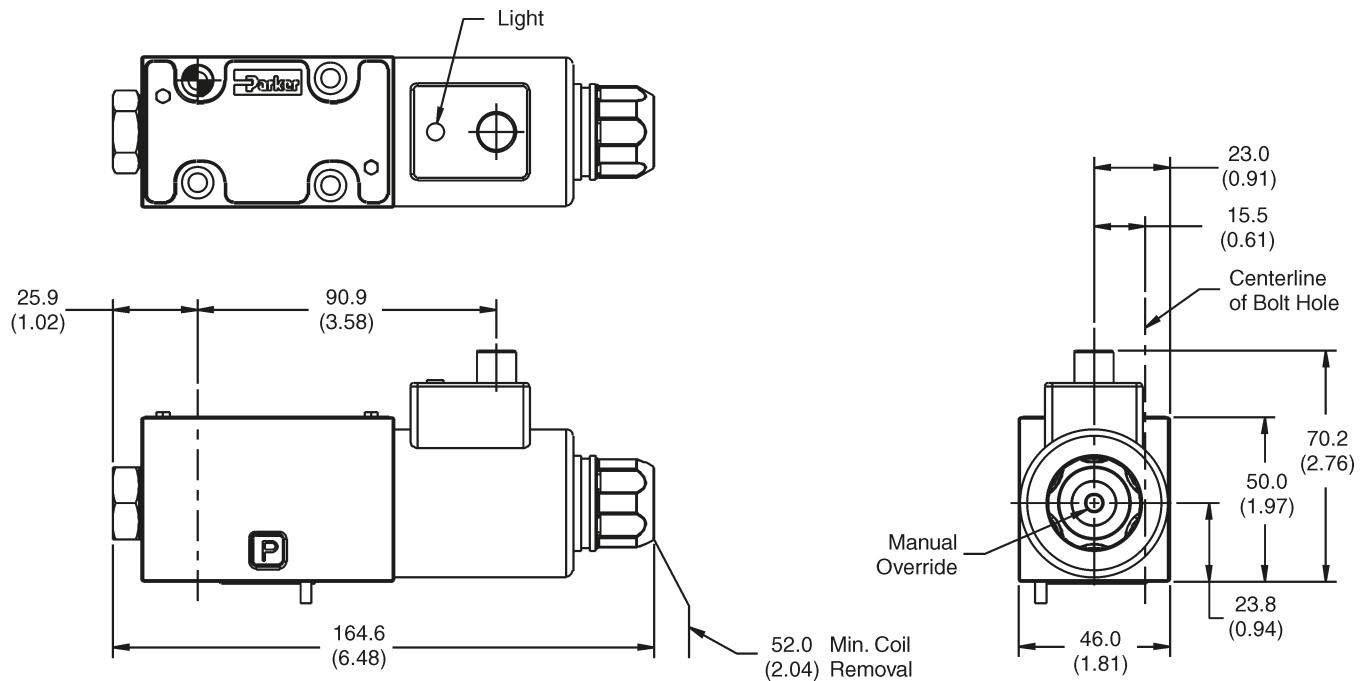

Note: 22.0 mm (0.87") from bottom of bolt hole counterbore to bottom of valve.

Inch equivalents for millimeter dimensions are shown in (**)

Explosion Proof U.L. & C.S.A., Double Solenoid

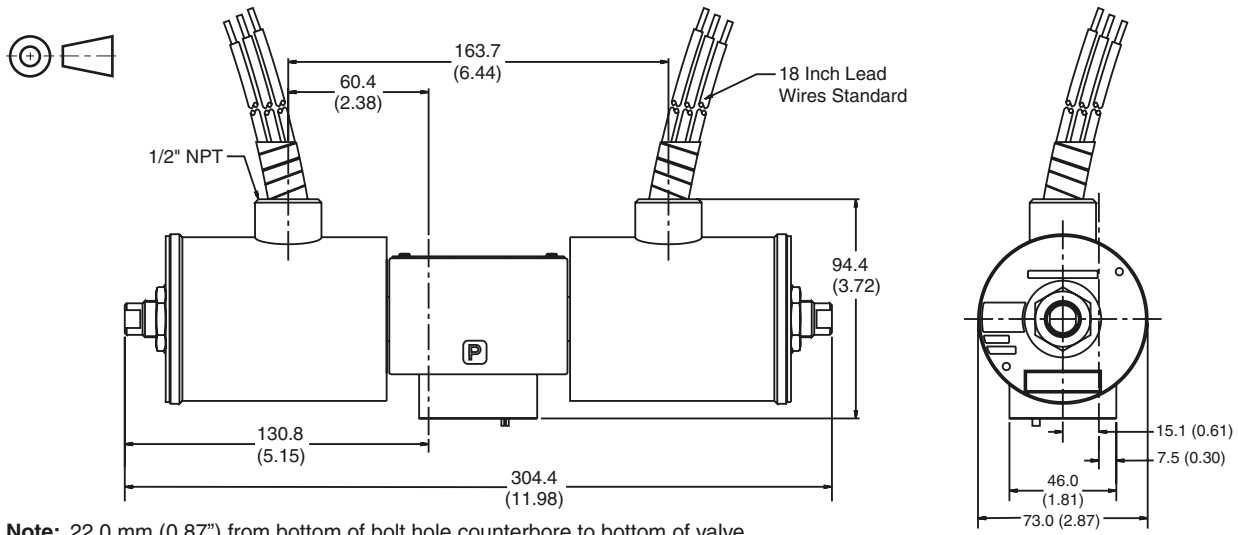

Note: 22.0 mm (0.87") from bottom of bolt hole counterbore to bottom of valve.

Explosion Proof M.S.H.A., Double Solenoid

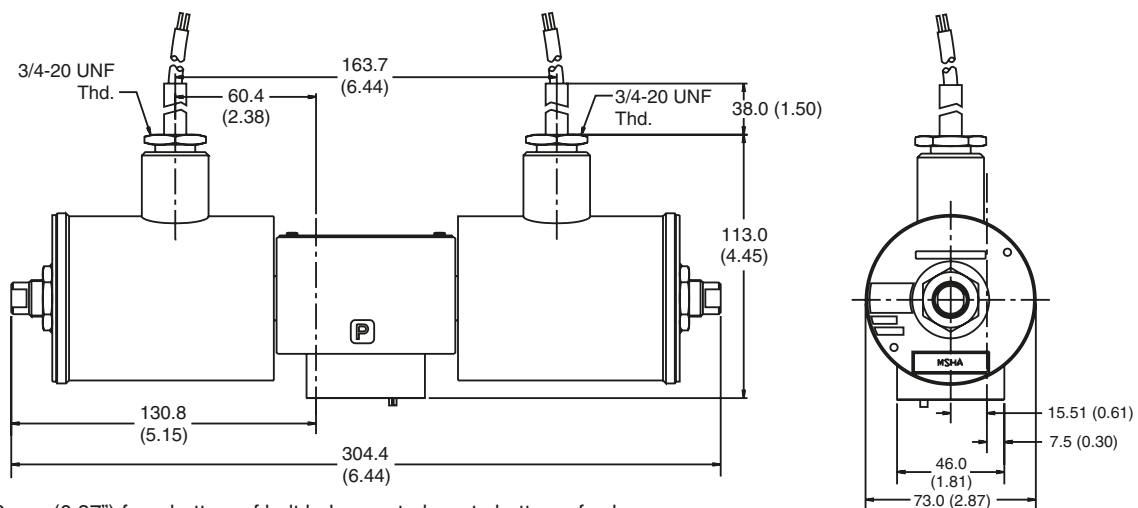

Note: 22.0 mm (0.87") from bottom of bolt hole counterbore to bottom of valve.

Explosion Proof ATEX, Double Solenoid

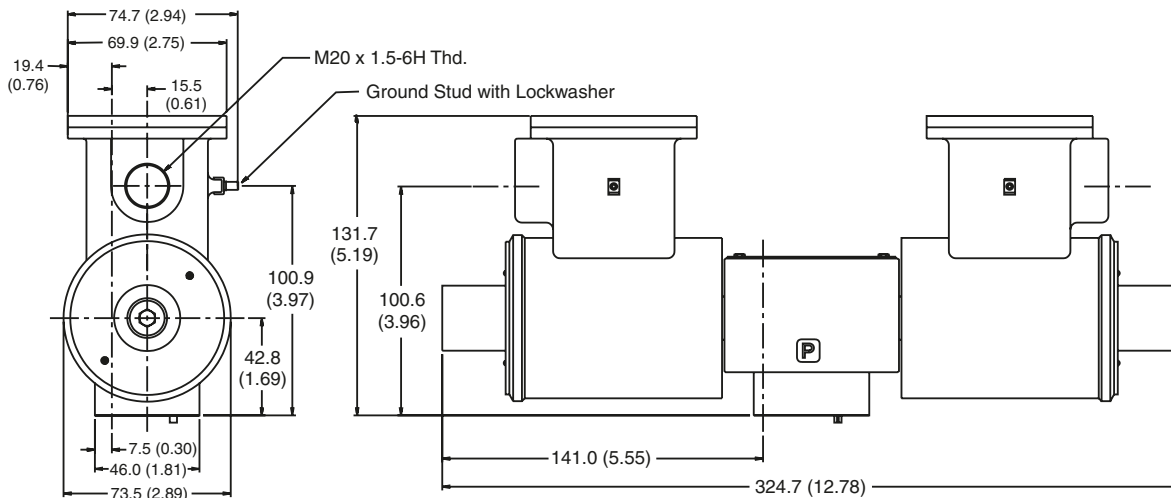

Cat H14-2536.indd, dd

Inch equivalents for millimeter dimensions are shown in (**)

**DC Plug-in or Leadwire Conduit Box with Monitor Switch,
with or without Lights, Single Solenoid**

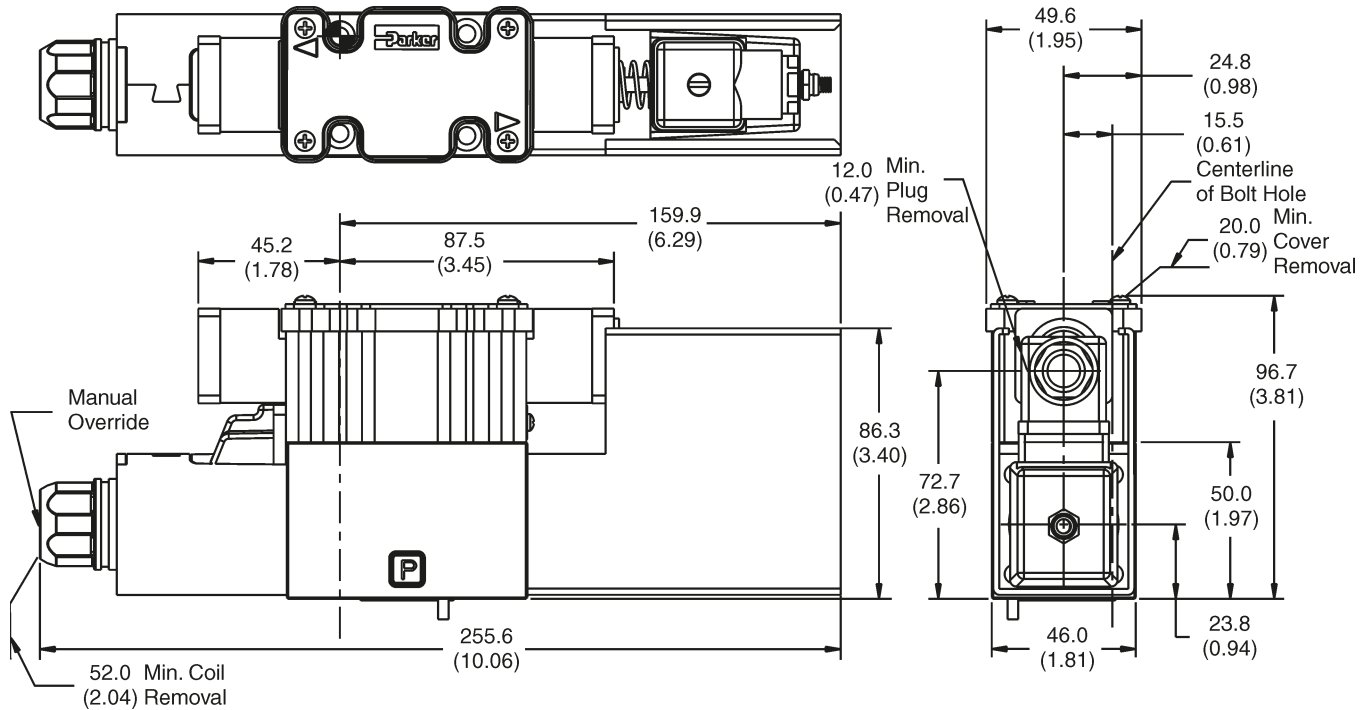

Note: 22.0 mm (0.87") from bottom of bolt hole counterbore to bottom of valve.



Monitor Switch

(valve variation I7 and I8)

This feature provides for electrical confirmation of the spool shift. This can be used in safety circuits, to assure proper sequencing, etc.

Switch Data

Inductive switch requiring +18-42 volt input. Outputs "A" and "B" are opposite; one at "0" voltage, the other at input voltage. During switching, "A" and "B" outputs reverse. Provides 0.4A switching current.

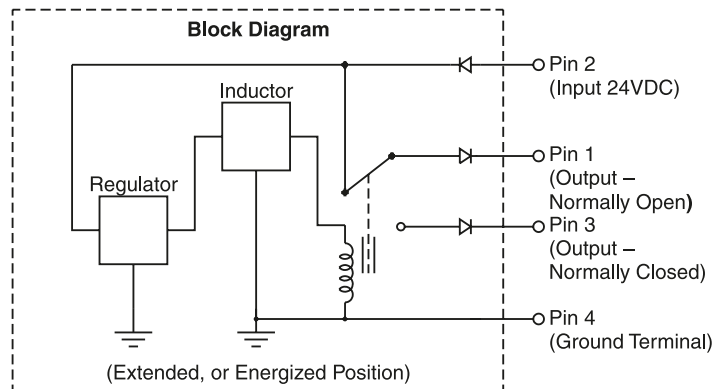

For repetitive switch power-up conditions, please consult factory.

Manaplug (Options 56 & 1C)

- Interface – Brad Harrison Plug
 – 3-Pin for Single Solenoid
 – 5-Pin for Double Solenoid

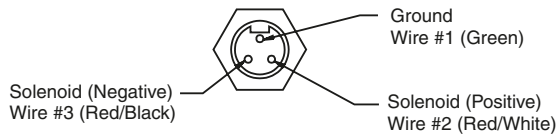

3-Pin Manaplug (Mini) with Lights

Single Solenoid Valves – Installed Opposite Side of Solenoid

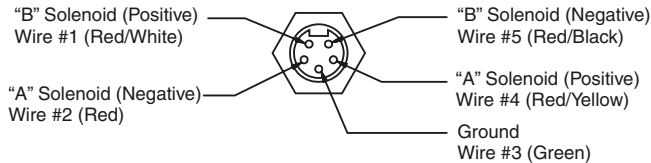

5-Pin Manaplug (Mini) with Lights

Single Solenoid Valves – Installed Opposite Side of Solenoid
 Double Solenoid Valves – Installed Over "A" Solenoid
 ("A" and "B" Solenoids Reversed for #8 and #9 Spools)

Micro Connector Options (7B & 1D)

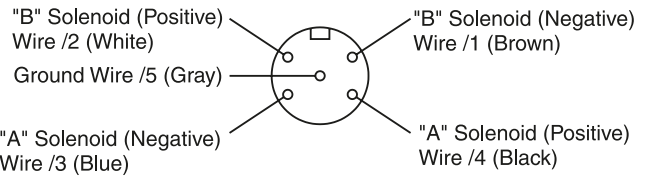
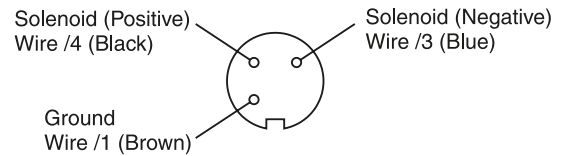

Pins are as seen on valve (male pin connectors).

Conduit Box Option C

- No Wiring Options Available

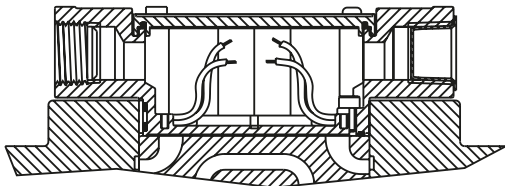

Signal Lights (Option 5) — Plug-in Only

- LED Interface
 – Meets Nema 4/IP67

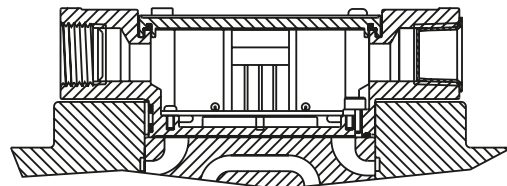

Hirschmann Plug with Lights (Option P5)

ISO 4400/DIN 43650 Form "A"

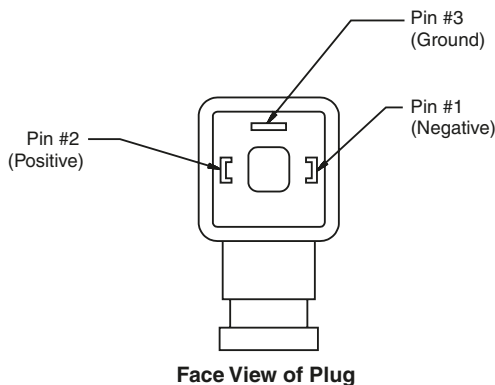

DESINA Connector (Option D)

**M12 pin assignment
Standard**

- 1 = Not used
 2 = Not used
 3 = 0V
 4 = Signal (24 V)
 5 = Earth Ground

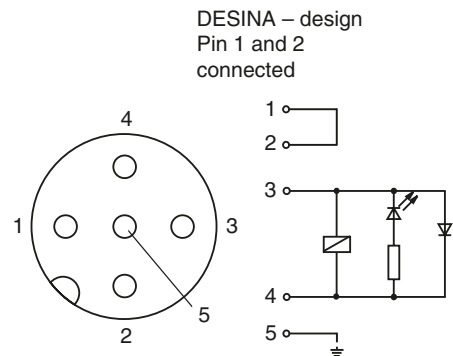

Pins are as seen on valve (male pin connectors).

Mounting Bolt Kits

Bolt Kits for use with D1V Directional Control Valves & Manapak (D1V*-82 & 70/75 Design, Solenoid Operated & D1V*-72 Design, Non-Solenoid Operated)

		Number of Manapaks/Cartpaks @40mm (1.58") thickness									
		0		1		2		3		4	
Number of Manapaks at 44.5mm (1.75") Thickness	0	BK209	1.25 in.	BK243	2.88 in.	BK225	4.38 in.	BK244	6.00 in.	BK245	7.50 in.
		BKM209	30 mm	BKM243	70 mm	BKM225	110 mm	BKM244	150 mm	BKM245	190 mm
	1	BK246	3.00 in.	BK247	4.62 in.	BK248	6.12 in.	BK249	7.75 in.		
		BKM246	75 mm	BKM247	115 mm	BKM248	155 mm	BKM249	195 mm		
	2	BK250	4.75 in.	BK251	6.38 in.	BK252	7.88 in.				
		BKM250	120 mm	BKM251	160 mm	BKM252	200 mm				
	3	BK253	6.50 in.	BK254	8.12 in.						
		BKM102	170 mm	BKM254	205 mm						
	4	BK103	8.25 in.								
		BKM103	210 mm								

Note: All bolts are SAE Grade 8, 10-24 UNC 2A thread (Metric-M5-0.8)
Torque to 5.6 Nm (50 in-Lb).

Bolt Kits for use with D1V Directional Control Valves with Explosion Proof Coils & Manapak (D1V*-82 & 70/75 Design)

		Number of Manapaks/Cartpaks @40mm (1.58") thickness									
		0		1		2		3		4	
Number of Manapaks at 44.5mm (1.75") Thickness	0	BK50	2.00 in.	BK211	3.63 in.	BK101	5.12 in.	BK102	6.75 in.	BK103	8.25 in.
		BKM50	50 mm	—	BKM101	130 mm	BKM102	170 mm	BKM103	210 mm	
	1	BK51	3.75 in.	BK212	5.37 in.	BK105	6.87 in.	BK106	7.75 in.		
		BKM51	95 mm	—	BKM107	180 mm	BKM106	195 mm			
	2	BK52	5.50 in.	BK213	7.13 in.	BK108	8.62 in.				
		BKM52	140 mm	—	BKM108	220 mm					
	3	BK53	7.25 in.	BK214	8.87 in.						
		BKM53	185 mm	—							
	4	BK54	9.00 in.								
		BKM54	230 mm								

Note: All bolts are SAE Grade 8, 10-24 UNC 2A thread (Metric-M5-0.8)
Torque to 5.6 Nm (50 in-Lb).

Sandwich Valve Dimensional Data

All D03 Manapak valves (starting with 31 Series) including CM2, CPOM2, FM2, PRDM2 and RM2 measure 40mm (1.58") thickness.

For additional technical information about Manapak valves, refer to the Manapak Sandwich Valve Section of this Catalog.

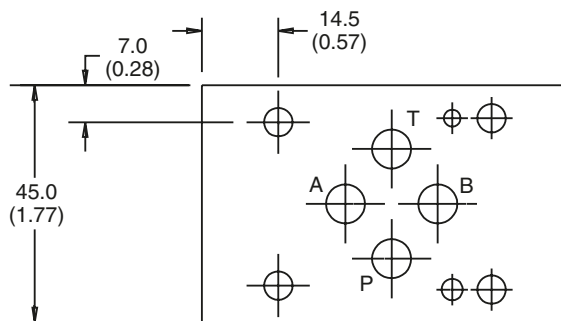

Fluid Recommendations

Premium quality hydraulic oil with a viscosity range between 32-54 cst. (150-250 SSU) at 38°C (100°F) is recommended. The absolute operation viscosity range is from 16-220 cst. (80-1000 SSU). Oil should have maximum anti-wear properties and rust and oxidation treatments.

Fluids and Seals

Valves using synthetic, fire-resistant fluids require special seals. When phosphate ester or its blends are used, FLUOROCARBON seals are required. Water-glycol, (95/5) water-in-oil emulsions, and petroleum oil may be used with NITRILE seals.

Temperature Recommendation

Recommended oil temperature:
-29°C to +71°C (-20°F to +160°F)

Ambient temperature:

AC High Watt ambient temperature cannot exceed 60°C (140°F).

DC High Watt, DC Low Watt and AC Low Watt ambient temperature cannot exceed 71°C (160°F).

Filtration

For maximum valve and system component life, the system should be protected at a contamination level not to exceed 125 particles greater than 10 microns per milliliter of fluid. (SAE Class 4 or better, ISO Code 16/13).

Tank Line Surges

If several valves are piped with a common tank line, flow surges in the line may cause unexpected spool shift. Detent style valves are most susceptible to this. Separate tank lines should be used when line surges are expected in an application.

Recommended Mounting Position

Valve Type	Recommended Mounting Position
Detent (Solenoid)	Horizontal
Spring Centered	Unrestricted
Spring Offset	Unrestricted

Silting

Silting can cause any sliding spool valve to stick and not spring return, if held shifted under pressure for long periods of time. The valve should be cycled periodically to prevent sticking.

Flow Path Data

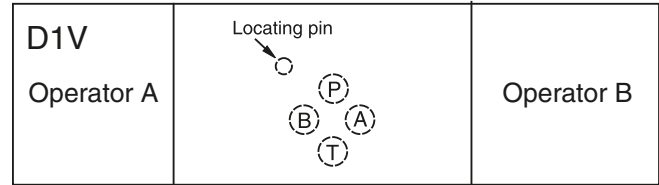

*Note: On valves with 008 or 009 spool, A and/or B operators reverse sides. Flow paths remain the same as viewed from top of valve.

Single Pass Operation

Valve flow ratings are for double pass operation (with equal flow in both paths). When using these components in single pass applications, flow capabilities may be reduced. Consult your local Parker representative for details.

Double Solenoid. With solenoid “A” energized, flow path is P→A and B→T. When solenoid “B” is energized, flow path is P→B and A→T. The center condition on a spring-centered valve exists when both coils are de-energized, or during a complete shift, as the spool passes through center.

Detent and Spring Offset. The center condition exists on detent and spring offset valves only during spool crossover. To shift and hold a detented spool, only a momentary energizing of the solenoid is necessary. The minimum duration of the signal is approximately 0.1 seconds for DC voltages. This position will be held provided the spool center line is in a horizontal plane, and no shock or vibration is present to displace the spool.

Single Solenoid. Spring offset valves can be ordered in styles B, E, F, H, K and M. Flow path data for the various styles are described in the order chart.

Electrical Failure

Should electric power fail, spring offset and spring centered valves will shift to the spring held position. Detented valves will stay in the last position held before power failure. If main flow does not fail or stop simultaneously, machine actuators may continue to function in an undesirable manner or sequence.

Torque Specifications

Torque values recommended for the bolts which mount the valve to the manifold or subplate are as follows:
#10-24 thread (M5-0.8) torque 5.6 Nm (50 in-lbs).

Terms of Sale with Warranty Limitations

Offer of Sale

The items described in this document and other documents or descriptions provided by Parker Hannifin Corporation, its subsidiaries and its authorized distributors are hereby offered for sale at prices to be established by Parker Hannifin Corporation, its subsidiaries and its authorized distributors. This offer and its acceptance by any customer ("Buyer") shall be governed by all of the following Terms and Conditions. Buyer's order for any such items, when communicated to Parker Hannifin Corporation, its subsidiary or an authorized distributor ("Seller") verbally or in writing, shall constitute acceptance of this offer.

1. Terms and Conditions of Sale: All descriptions, quotations, proposals, offers, acknowledgments, acceptances and sales of Seller's products are subject to and shall be governed exclusively by the terms and conditions stated herein. Buyer's acceptance of any offer to sell is limited to these terms and conditions. Any terms or conditions in addition to, or inconsistent with those stated herein, proposed by Buyer in any acceptance of an offer by Seller, are hereby objected to. No such additional, different or inconsistent terms and conditions shall become part of the contract between Buyer and Seller unless expressly accepted in writing by Seller. Seller's acceptance of any offer to purchase by Buyer is expressly conditional upon Buyer's assent to all the terms and conditions stated herein, including any terms in addition to, or inconsistent with those contained in Buyer's offer. Acceptance of Seller's products shall in all events constitute such assent.

2. Payment: Payment shall be made by Buyer net 30 days from the date of delivery of the items purchased hereunder. Amounts not timely paid shall bear interest at the maximum rate permitted by law for each month or portion thereof that the Buyer is late in making payment. Any claims by Buyer for omissions or shortages in a shipment shall be waived unless Seller receives notice thereof within 30 days after Buyer's receipt of the shipment.

3. Delivery: Unless otherwise provided on the face hereof, delivery shall be made F.O.B. Seller's plant. Regardless of the method of delivery, however, risk of loss shall pass to Buyer upon Seller's delivery to a carrier. Any delivery dates shown are approximate only and Seller shall have no liability for any delays in delivery.

4. Warranty: Seller warrants that the items sold hereunder shall be free from defects in material or workmanship for a period of 18 months from date of shipment from Parker Hannifin Corporation. **THIS WARRANTY COMPRISES THE SOLE AND ENTIRE WARRANTY PERTAINING TO ITEMS PROVIDED HEREUNDER. SELLER MAKES NO OTHER WARRANTY, GUARANTEE, OR REPRESENTATION OF ANY KIND WHATSOEVER. ALL OTHER WARRANTIES, INCLUDING BUT NOT LIMITED TO, MERCHANTABILITY AND FITNESS FOR PURPOSE, WHETHER EXPRESS, IMPLIED, OR ARISING BY OPERATION OF LAW, TRADE USAGE, OR COURSE OF DEALING ARE HEREBY DISCLAIMED. NOTWITHSTANDING THE FOREGOING, THERE ARE NO WARRANTIES WHATSOEVER ON ITEMS BUILT OR ACQUIRED WHOLLY OR PARTIALLY, TO BUYER'S DESIGNS OR SPECIFICATIONS.**

5. Limitation Of Remedy: SELLER'S LIABILITY ARISING FROM OR IN ANY WAY CONNECTED WITH THE ITEMS SOLD OR THIS CONTRACT SHALL BE LIMITED EXCLUSIVELY TO REPAIR OR REPLACEMENT OF THE ITEMS SOLD OR REFUND OF THE PURCHASE PRICE PAID BY BUYER, AT SELLER'S SOLE OPTION. IN NO EVENT SHALL SELLER BE LIABLE FOR ANY INCIDENTAL, CONSEQUENTIAL OR SPECIAL DAMAGES OF ANY KIND OR NATURE WHATSOEVER, INCLUDING BUT NOT LIMITED TO LOST PROFITS ARISING FROM OR IN ANY WAY CONNECTED WITH THIS AGREEMENT OR ITEMS SOLD HEREUNDER, WHETHER ALLEGED TO ARISE FROM BREACH OF CONTRACT, EXPRESS OR IMPLIED WARRANTY, OR IN TORT, INCLUDING WITHOUT LIMITATION, NEGLIGENCE, FAILURE TO WARN OR STRICT LIABILITY.

6. Changes, Reschedules and Cancellations: Buyer may request to modify the designs or specifications for the items sold hereunder as well as the quantities and delivery dates thereof, or may request to cancel all or part of this order, however, no such requested modification or cancellation shall become part of the contract between Buyer and Seller unless accepted by Seller in a written amendment to this Agreement. Acceptance of any such requested modification or cancellation shall be at Seller's discretion, and shall be upon such terms and conditions as Seller may require.

7. Special Tooling: A tooling charge may be imposed for any special tooling, including without limitation, dies, fixtures, molds and patterns, acquired to manufacture items sold pursuant to this contract. Such special tooling shall be and remain Seller's property notwithstanding payment of any charges by Buyer. In no event will Buyer acquire any interest in apparatus belonging to Seller which is utilized in the manufacture of the items sold hereunder, even if such apparatus has been specially converted or adapted for such manufacture and notwithstanding any charges paid

by Buyer. Unless otherwise agreed, Seller shall have the right to alter, discard or otherwise dispose of any special tooling or other property in its sole discretion at any time.

8. Buyer's Property: Any designs, tools, patterns, materials, drawings, confidential information or equipment furnished by Buyer or any other items which become Buyer's property, may be considered obsolete and may be destroyed by Seller after two (2) consecutive years have elapsed without Buyer placing an order for the items which are manufactured using such property, Seller shall not be responsible for any loss or damage to such property while it is in Seller's possession or control.

9. Taxes: Unless otherwise indicated on the face hereof, all prices and charges are exclusive of excise, sales, use, property, occupational or like taxes which may be imposed by any taxing authority upon the manufacture, sale or delivery of the items sold hereunder. If any such taxes must be paid by Seller or if Seller is liable for the collection of such tax, the amount thereof shall be in addition to the amounts for the items sold. Buyer agrees to pay all such taxes or to reimburse Seller therefore upon receipt of its invoice. If Buyer claims exemption from any sales, use or other tax imposed by any taxing authority, Buyer shall save Seller harmless from and against any such tax, together with any interest or penalties thereon which may be assessed if the items are held to be taxable.

10. Indemnity For Infringement of Intellectual Property Rights: Seller shall have no liability for infringement of any patents, trademarks, copyrights, trade dress, trade secrets or similar rights except as provided in this Part 10. Seller will defend and indemnify Buyer against allegations of infringement of U.S. Patents, U.S. Trademarks, copyrights, trade dress and trade secrets (hereinafter 'Intellectual Property Rights'). Seller will defend at its expense and will pay the cost of any settlement or damages awarded in an action brought against Buyer based on an allegation that an item sold pursuant to this contract infringes the Intellectual Property Rights of a third party. Seller's obligation to defend and indemnify Buyer is contingent on Buyer notifying Seller within ten (10) days after Buyer becomes aware of such allegations of infringement, and Seller having sole control over the defense of any allegations or actions including all negotiations for settlement or compromise. If an item sold hereunder is subject to a claim that it infringes the Intellectual Property Rights of a third party, Seller may, at its sole expense and option, procure for Buyer the right to continue using said item, replace or modify said item so as to make it noninfringing, or offer to accept return of said item and return the purchase price less a reasonable allowance for depreciation. Notwithstanding the foregoing, Seller shall have no liability for claims of infringement based on information provided by Buyer, or directed to items delivered hereunder for which the designs are specified in whole or part by Buyer, or infringements resulting from the modification, combination or use in a system of any item sold hereunder. The foregoing provisions of this Part 10 shall constitute Seller's sole and exclusive liability and Buyer's sole and exclusive remedy for infringement of Intellectual Property Rights.

If a claim is based on information provided by Buyer or if the design for an item delivered hereunder is specified in whole or in part by Buyer, Buyer shall defend and indemnify Seller for all costs, expenses or judgments resulting from any claim that such item infringes any patent, trademark, copyright, trade dress, trade secret or any similar right.

11. Force Majeure: Seller does not assume the risk of and shall not be liable for delay or failure to perform any of Seller's obligations by reason of circumstances beyond the reasonable control of Seller (hereinafter 'Events of Force Majeure'). Events of Force Majeure shall include without limitation, accidents, acts of God, strikes or labor disputes, acts, laws, rules or regulations of any government or government agency, fires, floods, delays or failures in delivery of carriers or suppliers, shortages of materials and any other cause beyond Seller's control.

12. Entire Agreement/Governing Law: The terms and conditions set forth herein, together with any amendments, modifications and any different terms or conditions expressly accepted by Seller in writing, shall constitute the entire Agreement concerning the items sold, and there are no oral or other representations or agreements which pertain thereto. This Agreement shall be governed in all respects by the law of the State of Ohio. No actions arising out of the sale of the items sold hereunder or this Agreement may be brought by either party more than two (2) years after the cause of action accrues.



Parker Safety Guide for Selecting and Using Hydraulic Valves and Related Accessories



WARNING: Failure or improper selection or improper use of Parker Hydraulic Valve Division (HVD) Valves or related accessories (“Products”) can cause death, personal injury and property damage. Possible consequences of failure or improper use of these Products include but are not limited to:

- Valves or parts thereof thrown off at high speed
- High velocity fluid discharge
- Explosion or burning of the conveyed fluid
- Contact with suddenly moving or falling objects controlled by the Valve
- Injections by high-pressure fluid discharge
- Contact with fluid that may be hot, cold, toxic or otherwise injurious
- Injuries resulting from injection, inhalation or exposure to fluids
- Injury from handling a heavy item (dropped, awkward lift)
- Electric shock from improper handling of solenoid connections
- Injury from slip or fall on spilled or leaked fluid

Before selecting or using any of these Products, it is important that you read and follow the instructions below. In general, the Products are not approved for in-flight aerospace applications. Consult the factory for the few that are FAA approved.

1.-1 **GENERAL INSTRUCTIONS**

- 1.1 **Scope:** This safety guide provides instructions for selecting and using (including assembling, installing and maintaining) these Products. For convenience all items in this guide are called “Valves”. This safety guide is a supplement to and is to be used in conjunction with the specific Parker catalogs for the specific Valves and/or accessories being considered for use. See item 1.6 below for obtaining those catalogs.
- 1.2 **Fail-Safe:** Valves can and do fail without warning for many reasons. Design all systems and equipment in a fail-safe mode, so that failure of the Valve or Valve Assembly will not endanger persons or property.
- 1.3 **Safety Devices:** Never disconnect, override, circumvent or otherwise disable any safety lockout on any system whether powered by HVD Valves or any motion control system of any manufacturer. (e.g. Automatic shut-off on a riding lawn mower should the operator get out of the seat).
- 1.4 **Distribution:** Provide a copy of this safety guide to each person that is responsible for selecting or using HVD Valve Products. Do not select HVD Valves without thoroughly reading and understanding this safety guide as well as the specific Parker catalogs for the Products considered or selected.
- 1.5 **User Responsibility:** Due the wide variety of operating conditions and applications for Valves, HVD and its distributors do not represent or warrant that any particular Valve is suitable for any specific system. This safety guide does not analyze all technical parameters that must be considered in selecting a product. The user, through its own analysis and testing is solely responsible for:
 - Making the final selection of the Valve
 - Assuring that the user’s requirements are met and that the application presents no health or safety hazards.
 - Providing all appropriate health and safety warnings on the equipment on which the Valves are used.
 - Assuring compliance with all applicable government and industry standards.
- 1.6 **Additional Questions:** Call the appropriate Parker technical service department if you have any questions or require any additional information. See the Parker publication for the product being considered or used, or call 1-800-CPARKER, or go to www.parker.com, for the telephone numbers of the appropriate technical service department. For additional copies of this or any other Parker Safety Guide go to www.parker.com and click on the safety button on the opening page. Catalogs and/or catalog numbers for the various HVD Valve Products can be obtained by calling HVD at 440-366-5100. Phone numbers and catalog information is also available on the Parker website, www.parker.com.

2.0 **VALVE SELECTION INSTRUCTIONS**

- 2.1 **Pressure:** Valve selection must be made so that the maximum working pressure of the Valve is equal to or greater than the maximum system pressure. Surge, impulse or peak transient pressures in the system must be below the maximum working pressure of the Valve. Surge, impulse and peak pressures can usually be determined by sensitive electrical instrumentation that measures and indicates pressures at millisecond intervals. Mechanical pressure gauges indicate only average pressure and cannot be used to determine surge, impulse or peak transient pressures. Burst pressure ratings if given or known are for manufacturing purposes only and are not an indication that the Product can be used in applications at the burst pressure or otherwise above the maximum working pressure.
- 2.2 **Temperature:** The fluid temperature must be regulated or controlled so that the operating viscosity of the fluid is maintained at a level specified for the particular Valve product. Such ranges are given in the product catalogs or can be obtained from the appropriate customer service department for the particular Valve product.
- 2.3 **Fluid Compatibility:** The fluid conveyed in Valves has direct implications on the Valve selection. The fluid must be chemically compatible with the Valve component materials. Elastomer seals, brass, cast iron, aluminum for example all are potentially affected by certain fluids. Additionally, fluid selection affects the performance of various Valves. Considerations relative to fluid selection are outlined in the specific HVD Valve product catalog. Of particular importance is that the fluid be for hydraulic use, contain the proper additives and wear inhibitors. See 1.6 “Additional Questions” above for information to obtain such HVD catalogs.
- 2.4 **Changing Fluids:** If a system requires a different fluid, it should be done with the guidance in number 2.3 above. Additionally, it may be necessary to flush the system (including the Valves) to remove any of the previous fluid. Consult the Parker Valve Division for guidance.
- 2.5 **Size:** Transmission of power by means of pressurized fluid varies with pressure and rate of flow. The size of the components must be adequate to keep pressure losses to a minimum and avoid damage due to heat generation or excessive fluid velocity.
- 2.6 **Placement:** Installation of Valves must take into account the orientation of the Valve and the proximity of the Valve to other parts of the system. This includes but is not limited to closeness to hot and cold areas, access for servicing and operation as well as orientation for proper connectors.
- 2.7 **Ports:** Connection of Valves in systems can be by threaded ports, sub-base surfaces, flanges and manifolds. In all cases, the proper fitting, surface or mounting hardware must be selected to properly seal and contain the system fluid so as to avoid the adverse conditions listed in the initial warning box above. Specifically, if using threaded ports, the designer must make sure that the mating fitting is of the compatible thread. Also, the instructions provided by the connector hardware supplier must be read and understood so as to properly assemble the connector. The Parker Safety Guide for using Hose, Tubing and Fittings and Related Accessories is but one reference to this end.
- 2.8 **Environment:** Care must be taken to insure that the Valve and Valve Assemblies are either compatible with or protected from the environment (that is, surrounding conditions) to which they are exposed. Environmental conditions including but not limited to ultraviolet radiation, sunlight, heat, ozone, moisture, water, salt water, chemicals and air pollutants can cause degradation and premature failure.
- 2.9 **Electric Power:** For Valves requiring electric power for control, it is imperative that the electricity be delivered at the proper voltage, current and wattage requirements. To obtain the proper control requirements please refer to the respective Parker product catalog for the specific Valve that is intended for use. If further guidance is required, call the appropriate technical service department identified in the respective Parker product catalog.
- 2.10 **Specifications and Standards:** When selecting Valves, government, industry and Parker specifications and recommendations must be reviewed and followed as applicable.
- 2.11 **Accessories:** All accessories used in conjunction with any Parker Valve product must be rated to the same requirements of the Valve including but not limited to pressure, flow, material compatibility, power requirements. All of these items must be examined as stated in the “VALVE INSTALLATION INSTRUCTIONS” paragraph 3.0.

(continued on next page)

3.0 VALVE INSTALLATION INSTRUCTIONS

- 3.1 **Component Inspection:** Prior to use, a careful examination of the Valve(s) must be performed. The Valve intended for use must be checked for correct style, size, catalog number and external condition. The Valve must be examined for cleanliness, absence of external defects or gouges, cracked or otherwise deformed parts or missing items. The mounting surface or port connections must be protected and free of burrs, scratches, corrosion or other imperfections. Do NOT use any item that displays any signs of nonconformance. In addition, any accessory including but not limited to fittings, bolt kits, hoses, sub bases, manifolds, and electrical connectors must be subjected to the same examination.
- 3.2 **Handling Valves:** Many Valves whether HVD Valves or of another manufacturer can be large, bulky or otherwise difficult to handle. Care must be taken to use proper lifting techniques, tools, braces, lifting belts or other aids so as not to cause injury to the user, any other person or to property.
- 3.3 **Filtration:** Fluid cleanliness is a necessity in any hydraulic system. Fluid filters must be installed and maintained in the system to provide the required level of fluid cleanliness. Filters can be placed in the inlets, pressure lines and return lines. The level of cleanliness required is specified in the HVD product catalog for the specific Valve(s) selected or intended for use. For additional information on Filter selection contact Parker Filter Division at 800-253-1258 or 419-644-4311.
- 3.4 **Servo Valves:** Application of Servo Valves in general requires knowledge and awareness of “closed loop control theory” and the use of electronic controls for successful and safe operation. Individuals who do not have such experience or knowledge must gain training before use of such Products. Parker offers both classroom training as well as manuals to individuals in gaining this knowledge. These aids can be obtained by contacting Hydraulic Valve Division at 440-366-5100, calling the general Parker help line 800-CPARKER or going to the Parker web site at www.parker.com.
- 3.5 **Accessory Ratings:** All accessories used in combination with the selected or intended Valve product must be rated and compatible with the selected Valve. Specifically, the items must be of equal or greater rating including but not limited to pressure, flow, power, size, port style, thread connectors and material.
- 3.6 **Connection Styles:** It is the responsibility of the user of the Parker product to properly select connectors and accessories that match the connections on the sub plate, Valve, flange or threaded connection or manifold. It is also the responsibility of the installer to possess adequate skill and knowledge including but not limited to thread preparation, torque technique, hose assembly and inspection, tube preparation and assembly, and fitting installation. Parker Tube Fitting Division (www.parker.com/tfd) catalog 4300 and Parker Hose Products (www.parkerhose.com) catalog 4400 describe some basic technical information relative to proper fitting assembly.
- 3.7 **Electrical Connections:** All electrical connections must be made to the applicable codes and local safety requirements.
- 3.8 **Gauges and Sensors:** The user must install sufficient gauges and sensors in the system so as to be able to determine the condition of the system. This includes but is not limited to pressure gauges, flow meters, temperature sensors and site gauges. These are of utmost importance should removal or disassembly of a Valve, portion of a Valve or portion of the system become necessary. Refer to “VALVE MAINTENANCE AND REPLACEMENT INSTRUCTIONS” for details and especially item 4.8.
- 3.9 **System Checkout:** Once installed, the Valve installation must be tested to insure proper operation and that no external leakage exists. All safety equipment must be in place including but not limited to safety glasses, helmets, ear protection, splash guards, gloves, coveralls and any shields on the equipment. All air entrapment must be eliminated and the system pressurized to the maximum system pressure (at or below the Valve maximum working pressure) and checked for proper function and freedom from leaks. Personnel must stay out of potentially hazardous areas while testing and using.

4.0 VALVE MAINTENANCE AND REPLACEMENT INSTRUCTIONS

- 4.1 **Maintenance Program:** Even with proper installation, Valves and Valve System life may be significantly reduced without a continuing maintenance program. The severity of the application and risk potential must determine the frequency of the inspection and the replacement of the Products so that Products are replaced before any failure occurs. A maintenance program must be established and followed by the user and, at a minimum, must include instructions 4.2 through 4.10. An FMEA (Failure Mode and Effects Analysis) is recommended in determining maintenance requirements.
- 4.2 **Visual Inspection-Valves:** Any of the following conditions require immediate shut down and replacement of the Valve.
- Evidence that the Valve is in partial dis-assembly.
 - Visible crack or suspicion of a crack in the Valve housing or bent, cracked or otherwise damaged solenoid.
 - Missing or partially extending drive pin on a flow control knob.
 - Missing, loose components, obstructions or other condition impeding the motion or function of the manual knob, lever, foot pedal or other mechanical operator of a hydraulic Valve.
 - Any evidence of burning or heat induced discoloration.
 - Blistered, soft, degraded or loose cover of any kind.
 - Loose wire or electrical connector.
- 4.3 **Visual Inspection-Other:** The following conditions must be tightened, repaired, corrected or replaced as required.
1. Fluid on the ground must be cleaned immediately. Also, the source of the fluid must be determined prior to running the equipment again.
 2. Leaking port or excessive external dirt build-up.
 3. System fluid level is too low or air is entrapped or visible in the reservoir.
 4. Equipment controlled by the Valve or Valve assembly has been losing power, speed, efficiency
- 4.4 **Filter Maintenance:** System filters must be maintained and kept in proper working order. The main service requirement is periodic replacement of the filter element or screen. Contact Parker Filter Division at 800-253-1258 or 419-644-4311 for further filter maintenance details.
- 4.5 **Functional Test:** See “System Checkout” number 3.9 above in “VALVE INSTALLATION INSTRUCTIONS”.
- 4.6 **Replacement Intervals:** Valves and Valve Systems will eventually age and require replacement. Seals especially should be inspected and replaced at specific replacement intervals based on previous experience, government or industry recommendations, or when failures could result in unacceptable downtime, damage or injury risk. At a minimum seals must be replaced whenever service is rendered to a Valve product.
- 4.7 **Adjustments, Control Knobs, and Other Manual Controls:** System Pressure and Flow are typically adjusted by knobs and/or handles. A set-screw or lock-nut secures the adjustment device so as to maintain the desired setting. This set-screw or lock-nut must first be loosened prior to making any adjustments and re-tightened after adjustment on the HVD Valve. All adjustments must be made in conjunction with pressure gauges and/or flow meters (or by watching the speed of the actuator in the case of setting flow only). See paragraph “Gauges and Sensors” above in the section “VALVE INSTALLATION INSTRUCTIONS”. Under no circumstances should any control knob, adjustment stem, handle, foot pedal or other actuating device be forced beyond the mechanical stop(s) on the Valve. For example, the Parker Safety Notice Bulletin **HY14-3310-B1/US** for HVD Colorflow Valves specifically restricts the adjustment torque to “hand adjust” or “less than 10 ft/lbs” if it cannot be adjusted by hand. Failure to adhere to this may force the knob beyond the stop point allowing it to be ejected at high speed resulting in death, personal injury and property damage. For complete safety instructions on HVD Colorflow Valves, copies of Safety Notice **Bulletin HY14-3310-B1/US** can be obtained directly from the Hydraulic Valve Division at 440-366-5100 or from the Parker web site at www.parker.com by selecting the “Safety” button. Parker help line 800-CPARKER is on call 24/7 as well should there be any question about the use of a HVD Valve. Additionally, when making adjustments, always adjust the Valve with all parts of your body to the side of the Valve (that is, the knob is not pointing toward you or anyone else).
- 4.8 **High pressure Warning:** Hydraulic power is transmitted by high-pressure fluids through hoses, fittings and valves, pumps and actuators. This condition can be dangerous and potentially lethal and, therefore, extreme caution must be exercised when working with fluids under pressure. From time to time, hoses, Valves, tubes or fittings fail if they are not replaced at proper time intervals. Typically these failures are the result of some form of misapplication, abuse, wear, or failure to perform proper maintenance. When such failure occurs, generally the high pressure fluid inside escapes in a stream which may or may not be visible to the user. Under no circumstances should the user attempt to locate the leak by “feeling” with their hands or any other part of their body. High-pressure fluids can and will penetrate the skin and cause severe tissue damage and possible loss of limb or life. Even seemingly minor hydraulic fluid injection injuries must be treated immediately by a physician with knowledge of the tissue damaging properties of hydraulic fluid. If a hose, tube, fitting or Valve failure occurs, immediately shut down the equipment and leave the area until pressure has been completely released from the system. Simply shutting down the pump may or may not eliminate the pressure in the system. It may take several minutes or even hours for the pressure to be relieved so that the leak area can be examined safely. Once the pressure has been reduced to zero, the suspected leaking item can be taken off the equipment and examined. It must always be replaced if a failure has occurred. Never attempt to patch or repair a connector (especially a hose) or Valve that has failed. Consult the nearest Parker distributor or the appropriate Parker division for component replacement information. Never touch or examine a failed hydraulic component unless it is obvious that the item no longer contains fluid under pressure.

Parker Hydraulics International Sales Offices

North America

Hydraulics Group Headquarters

6035 Parkland Boulevard
Cleveland, OH 44124-4141 USA
Tel: 216-896-3000
Fax: 216-896-4031

Parker Hannifin Canada

Motion & Control Division – Milton

160 Chisholm Drive Milton
Ontario Canada L9T 3G9
Tel: 905-693-3000
Fax: 905-876-1958

Motion & Control Division – Montreal

2001 rue de l'aviation
Dorval, Quebec, H9P 2X6
Tel: 514-684-3000
Fax: 514-684-4191

Motion & Control Division – Calgary

3141B – 16th Street N.E.
Calgary, Alberta T2E 7K8
Tel: 403-291-9284
Fax: 403-291-9285

Mexico

Parker Hannifin de Mexico, S.A. C.V

Via de Ferrocarril a Matamoros 730
Apodaca, N.L. C.P. 66600, Mexico
Tel: 01-8181-566036 y 96

Parker Hannifin de México

Av eje uno norte num 100
Parque Industrial Toluca 2000
Toluca, Mex C.P. 50100
Tel: 52 722 2754200
Fax: 52 722 2799308

Mobile Sales

Mobile Sales Organization and Global Sales

595 Schelter Road
Suite 100
Lincolnshire, IL 60069 USA
Tel: 847-821-1500
Fax: 847-821-7600

Industrial Sales

Great Lakes Region

3700 Embassy Parkway Suite 260
Fairlawn, OH 44333 USA
Tel: 330-670-2680
Fax: 330-670-2681

Southern Region

1225 Old Alpharetta Road Suite 290
Alpharetta, GA 30005 USA
Tel: 770-619-9767
Fax: 770-619-9806

Chicago Region

1163 E. Ogden Avenue
Suite 705, #358
Naperville, IL 60563 USA
Tel: 630-964-0796
Fax: 866-473-9274

Pacific Region

8460 Kass Drive
Buena Park, CA 90621
Tel: 714-228-2510
Fax: 714-228-2511

Eastern Region

100 Corporate Drive
Lebanon, NJ 08833 USA
Tel: 908-236-4121
Fax: 908-236-4146

Europe

Europe Hydraulics Group

Parker Hannifin Corporation

Parker House
55 Maylands Avenue
Hemel Hempstead, Herts
HP2 4SJ England
Tel: 44 1442 458000
Fax: 44 1442 458085

Austria

Parker Hannifin GmbH

Badener Strasse 12
AT-2700 Wiener Neustadt, Austria
Tel: 43 2622-23501 970
Fax: 43 2622-23501 977

Belarus

Parker Hannifin Corporation

Pr. Nezavisimosti, 11, Office 524
BY-220030 Minsk, Belarus
Tel: 375 17 209 9399
Fax: 375 17 209 9227

Belgium

Parker Hannifin SA NV

ZI Sud 2
23, Rue du Bosquet
BE-1400 Nivelles, Belgium
Tel: 32 67 280 900
Fax: 32 67 280 999

Czech Republic/Slovakia

Parker Hannifin s.r.o.

Parkerova 623
CZ-250 67 Klecany, Czech Republic
Tel: 420 284 083 111
Fax: 420 284 083 112

Denmark

Parker Hannifin Denmark A/S

Industriparken 35-37
DK-2750 Ballerup, Denmark
Tel: 45 43 56 04 00
Fax: 45 43 73 31 07

Finland

Parker Hannifin Oy

Ylästöntie 16
FI-01520 Vantaa, Finland
Tel: 358 20 753 2500
Fax: 358 20 753 2200

France

Parker Hannifin France SAS

142, rue de la Forêt
FR-741 30 Contamine sur Arve, France
Tel: 33 4-50 25 80 25
Fax: 33 4-50 03 67 37

Germany/Switzerland

Parker Hannifin GmbH & Co. KG

Pat-Parker-Platz 1
DE-41564 Kaarst, Germany
Tel: 49 (0) 2131 4016 0
Fax: 49 (0) 2131 4016 9199

Greece

Parker Hannifin Corporation

197 Syngrou Av.
GR-171 21 Athens, Greece
Tel: 0030 210 933-6450
Fax: 0030 210 933-6451

Hungary

Parker Hannifin Corporation Hungarian Trade Representative Office

Egressy u. 100
HU-1149 Budapest, Hungary
Tel: 36 1 220 4155
Fax: 36 1 422 1525

Europe

Ireland

Parker Hannifin Ireland Ltd

Baldonnell Business Park
Baldonnell
Naas Road
IE-Co. Dublin, Ireland
Tel: 353 (0)1 466 63 70
Fax: 353 (0)1 466 63 76

Italy

Parker Hannifin SpA

Via Privata Archimede 1
IT-200 94 Corsico (MI), Italy
Tel: 39 02-45 19 21
Fax: 39 02-44 79 340

Latvia (Lithuania, Kaliningrad)

Parker Hannifin Corporation

79A Slokas Street, Office No. 6
LV-1007 Riga, Latvia
Tel: 371 74 52 601
FAX: 371 74 52 608

The Netherlands

Parker Hannifin BV

Edisonstraat 1
NL-7575 AT Oldenzaal, The Netherlands
Tel: 31 541 585 000
Fax: 31 541 585 459

Norway

Parker Hannifin A/S

Berghagan
PO Box 3008
NO-1402 Ski, Norway
Tel: 47 64-91 10 00
Fax: 47 64-91 10 90

Poland

Parker Hannifin Sp.z.o.o

ul. Równolegla 8
PL-02-435 Warszawa, Poland
Tel: 48 22 573 24 00
Fax: 48 22 573 24 03

Portugal

Parker Hannifin Portugal, Lda

Travessa da Bateria 184 R/C
Dto./1 Esq.
PT-4450-625 Leça da Palmeira, Portugal
Tel: 351 22 999 7360
Fax: 351 22 996 1527

Romania

Hidro Consulting Impex SRL

Bld Ferdinand nr 27, Sect 2
RO-021381 Bucharest, Romania
Tel: 40 21 252 13 82
Fax: 40 21 252 33 81

Russia

Moscow

Parker Hannifin LLC

8-go Marta str., 6A, build 1
RU-127083 Moscow, Russia
Tel: 7 495 645 21 56
Fax: 7 495 612 18 60

Sakhalin

Parker Hannifin LLC Branch Office Sakhalin

Pr. Mira 1
RU-693012 Yuzhno-Sakhalinsk, Russia
Tel: 7 4242 42 35 27
Fax: 7 4242 42 35 27

(continued on next page)



Parker Hydraulics International Sales Offices

Europe

Spain

Parker Hannifin España SA
P.O. Box No. 74
P. I. Las Monjas, c/Estaciones, 8
ES-28850 Torrejón de Ardoz
Madrid, Spain
Tel: 34 91-675 73 00
Fax: 34 91-675 77 11

Sweden

Parker Hannifin AB
Fagerstagatan 51
Box 8314
SE-163 08 Spånga, Sweden
Tel: 46 8 5979 50 00
Fax: 46 8 5979 51 10

Parker Hannifin AB
Almenäsvägen 22
SE-501 78 Borås, Sweden
Tel: 46 33 700 52 00
Fax: 46 33 13 89 40

Turkey

Parker Hannifin Corporation
Liaison Office of Turkey
Merter Is Merkezi
Gen. Ali Riza Gurcan cad. No: 2 / 67
TR-34067 Merter/Istanbul, Turkey
Tel: 90 212 482 91 06/07
Fax: 90 212 482 91 10

Ukraine

Parker Hannifin Corporation
Representation Office in Ukraine
vul. Velyka Vasylkivska 9/2 Office 59
UA-01004 Kyiv, Ukraine
Tel: 380 44 494 2731/2732/2724
Fax: 380 44 494 2730

United Kingdom

Parker Hannifin Ltd
Tachbrook Park Drive
Tachbrook Park
UK-Warwick, CV34 6 TU, England
Tel: 44 1926 317 878
Fax: 44 1926 317 855

South Africa

Parker Hannifin Africa Pty Ltd
Parker Place
10 Berne Avenue Aeroport
P.O. Box 1153
ZA-Kempton Park 1620,
Republic of South Africa
Tel: 27 11 961 0700
Fax: 27 11 392 7213

Middle East

Azerbaijan

Parker Hannifin plc
Azpar, Technical Representative
140 Alovst Guliyev St. Apt. 10
AZ-1000 Baku, Azerbaijan
Tel: 99 412 598 3966
Fax: 99 412 598 3966

Egypt

Parker Hannifin Corporation
8B Zahraa Maadi
Region 17F
Cairo, Egypt
Tel: (20) 2 5194018
Fax: (20) 2 5190605

Middle East

Kazakhstan

Parker Hannifin
Gateway Ventures CA Ltd,
Representative
7A Kabanbai Batira
KZ-480100 Alamy, Kazakhstan
Tel: 7 3272 505 800
Fax: 7 3272 505 801

Asia Pacific

Asia Pacific Headquarters
Parker Hannifin Hong Kong Ltd
8/F, Kin Yip Plaza
9 Cheung Yee Street
HK-Cheung Sha Wan, Hong Kong
Tel: 852 2428 8008
Fax: 852 2425 6896

Australia Headquarters

Parker Hannifin Pty Ltd.
9 Carrington Road
Castle Hill, NSW 2154, Australia
Tel: 612 9634 7777
Fax: 612 9842 5111

China Headquarters

Parker Hannifin Motion & Control
(Shanghai) Co., Ltd
280 Yunqiao Road,
Jin Qiao Export Processing Zone
CN-Shanghai 201206, China
Tel: 86 21 5031 2525
Fax: 86 21 5834 3714

Parker Tejing

Hydraulic Tianjin
21 Hongyuan Road
Xiqing Development Zone
CN-Tianjin 300385, China
Tel: 86 22 5838 8899
Fax: 86 22 5838 8917

India

Parker Hannifin India Pvt Ltd
Plot No. EL-26, MIDC, TTC Industrial Area
Mahape,
IN-Navi Mumbai 400 709, India
Tel: 91 22 5613 7081/7082/7083/7084
Fax: 91 22 2768 6841/6618

Japan

Parker Hannifin Japan Ltd
Shirokanedai Building 2nd Floor
3-2-10, Shirokanedai, Minato-ku
JP-Tokyo, 108-0071, Japan
Tel: 81 3 6408 3900
Fax: 81 3 5449 7201

Korea Headquarters

Parker Hannifin Korea Ltd
6F Daehwa Plaza
169 Samsung-dong, Gangnam-gu
KR-Seoul, 135-090, Korea
Tel: 82 2 559 0400
Fax: 82 2 556 8187

Malaysia

Parker Hannifin Singapore Pte Ltd
(Malaysia Branch Office)
Lot 558A, Jalan Subang 3
Off Persiaran Subang
Sungai Penaga Industrial Park
MY-47610 Subang Jaya, Malaysia
Tel: 60 (0)3 5638 1476
Fax: 60 (3)3 5638 1527

Asia Pacific

New Zealand

Parker Hannifin (N.Z.) Ltd
3 Bowden Road
Mt. Wellington, Auckland, New Zealand
Tel: 64 9 574 1744
Fax: 64 9 573 1529

Singapore

Parker Hannifin Singapore Pte Ltd
No. 11 Fourth Chin Bee Road
SG-Singapore 619702,
Republic of Singapore
Tel: 65 6887 6300
Fax: 65 6265 5125

Taiwan

Parker Hannifin Taiwan Co., Ltd
No. 40, Wuchuan 3rd Rd.,
Wuku Industrial Park
Taipei County, Taiwan 248, R.O.C.
Tel: 886 2 2298 8987
Fax: 886 2 2298 8982

Thailand

Parker Hannifin Thailand Co., Ltd
1023, 3rd floor, TPS building
Pattanakarn Road, Suanluang
Bangkok 10250, Thailand
Tel: 662 717 8140
Fax: 662 717 8148

Latin America

Pan American Division

7400 NW 19th Street, Suite A
Miami, FL 33126 USA
Tel: 305-470-8800
Fax: 305-470-8808

Argentina

Parker Hannifin Argentina SAIC
Stephenson 2711 esq. Costa Rica
1667 Tortuguitas
Buenos Aires, Argentina
Tel: 54 3327 44 4129
Fax: 54 3327 44 4199

Brazil

Hydraulics Division

Parker Hannifin Ind. e Com. Ltda
Av. Frederico Ritter, 1100
Cachoeirinha RS, 94930-000 Brazil
Tel: 55 51 3470 9144
Fax: 55 51 3470 3100

Chile

Parker Hannifin Chile Ltda
Av. Americo Vespucio 2760-E
Conchali - Santiago, Chile
Tel: 56-2-623-1216
Fax: 56-2-623-1421

Venezuela

Parker Hannifin de Venezuela, SA
Av. Principal con calle Miraima
Edificio Draza, Boleita Norte
Caracas, Venezuela
Tel: 58 212 238 5422
Fax: 58 212 239 2272



Extensive Hydraulic Product Offering

Accumulators



Piston, bladder and diaphragm type accumulators, gas bottles and KleenVent reservoir isolators.

www.parker.com/accumulator

Compact Hydraulics



Self-contained with a motor, gear pump, reservoir, internal valving, load hold checks and relief valves.

www.parker.com/oilydne

Cylinders



Standard and custom hydraulic cylinders for industrial and mobile applications.

www.parker.com/hydcyl

Electronics/Remote Controls



Parker's unique IQAN approach combines sturdy, well-tested hardware with intelligent, flexible computing power.

www.parker.com/iqan

Filtration



Pressure and return line filters enhances machine life, reduces maintenance and lowers costs.

www.parker.com/hydraulicfilter

Integrated Hydraulic Circuits



Solutions for complex circuits that include threaded cartridge valves integrated into a single manifold.

www.parker.com/ihd

Motors



Full line of high and low speed motors provides power up to 15,000 in-lbs of torque.

www.parker.com/pumpmotor

Power Take Off



Parker Chelsea leads the industry for engineering, innovation and performance in auxiliary power systems.

www.parker.com/chelsea

Power Units



The most complete line of standard, pre-engineered, cataloged hydraulic power units in the industry.

www.parker.com/pumpmotor

Pumps



Broad line of energy-efficient hydraulic pumps that includes piston, vane and gear pumps.

www.parker.com/mobpump

Rotary Actuator



Industry leader in the design and manufacture of hydraulic rack and pinion, and vane style rotary actuators.

www.parker.com/actuator

Valves and Controls



Hydraulic valves for virtually every hydraulic equipment application, from simple to precise control.

www.parker.com/hydraulicvalve

Covering the Industrial, Mobile and Truck markets, each catalog is paired with an interactive CD. Call for your comprehensive guides today. 1-800-CParker

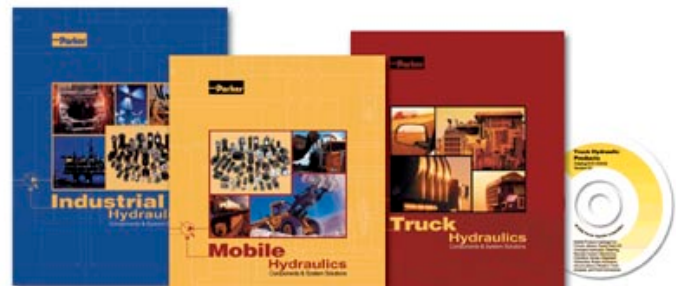

*Industrial Bulletin
HY01-1000/US*

*Mobile Bulletin
HY19-1001/US*

*Truck Bulletin
HY19-1004/US*

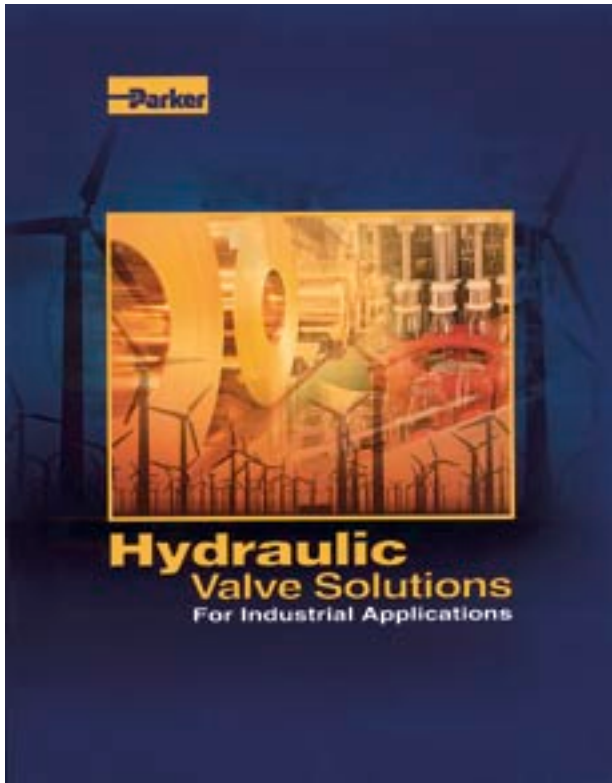

Bulletin HY14-2530/US
Catalog CD HY14-2530/US (included inside brochure)

For the latest hydraulic valve information
www.parker.com/hydraulicvalve

To locate your nearest hydraulic valve distributor
www.parker.com/hyd/distloc

For North America, Europe and the rest of the world regional offices, see Parker Hydraulics International Sales Offices at the back of this catalog.



Parker Hydraulic Valve wants to keep you informed. Listed below are connection opportunities for you to resource additional information or speak directly with the industry's most knowledgeable hydraulic valve professionals.

To order literature or locate a distributor by phone
1-800-C-Parker

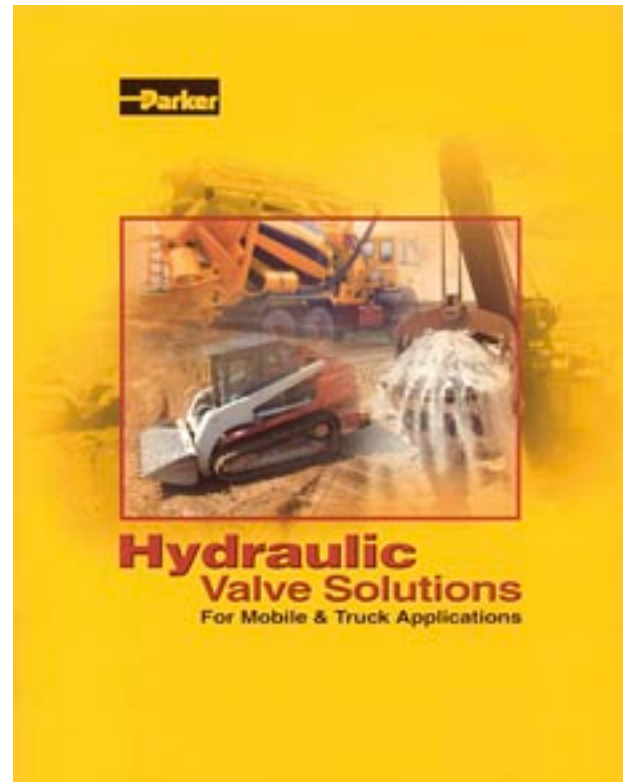

Bulletin HY14-2400/US
Catalog CD HY14-2400/US (included inside brochure)

Parker Hannifin Corporation
Hydraulic Valve Division
520 Ternes Avenue
Elyria, Ohio, 44035 USA
Tel: (440) 366-5200
Fax: (440) 366-5253
www.parker.com/hydraulicvalve

Catalog HY14-2536/US,
4M, 4/07, PPI