



AE5-1412 R2

November 2018

Copeland Scroll™ Outdoor Refrigeration Unit X-Line User Manual

TABLE OF CONTENTS

Safety Instructions..... 4
Safety Icon Explanation 4
Instructions Pertaining to Risk of Electrical Shock, Fire, or Injury to Persons 5
Safety Statements 5
1 Introduction 6
2 Inspection 6
3 Installation 6
3.1.1 Mounting Location..... 7
3.1.2 Piping 7
3.2 Electrical Connections..... 7
3.3 Evaporator connections and considerations 9
3.3.1 Evaporators with built-in Time Delay 9
3.3.2 Evaporators with built-in defrost controls 9
3.3.3 Evaporators with electronic expansion valves (EXV)..... 9
3.3.4 Superheat Requirements 9
3.4 Leak Check and Refrigerant Charging..... 10
3.5 Initial Startup 10
3.5.1 Incorrect Phase Sequence Protection 10
3.5.2 Flooded start protection (Bump Start)..... 10
3.5.3 Default Settings..... 10
3.6 Main Settings 11
3.6.1 How to Adjust Settings 11
3.6.2 Real Time Clock..... 11
3.6.3 Low Ambient, Low Pressure Control Operations..... 11
3.6.4 Refrigerant and Pressure Control Settings 11
3.6.5 Defrost Mode Selection..... 12
3.7 Advanced Settings 12
3.7.1 Auto / Manual Restart 12
3.7.2 Anti-short cycle control..... 12
3.7.3 Low Condensing Operation 13
3.7.4 Low Ambient Operation 13
4 Use and Operation 13
4.1 User Interface..... 13
4.1.1 Button Descriptions and Key Combinations 14
4.1.2 Changing a Parameter Value..... 15
4.1.3 Entering the Advanced Options Menu 15
4.1.4 Moving Parameters Between the Programming Menu and the Advanced Options Menu..... 15
4.1.5 Locking the Keypad..... 15
4.1.6 Unlocking the Keypad 15
4.1.7 Fast Access Menu..... 15
4.1.8 Alarm Menu 17
4.1.9 How to Program a HOT-KEY from the Controller (UPLOAD TO OVERWRITE HOT-KEY)..... 17
4.1.10 How to Program a Controller Using a HOT-KEY (Download) 17
4.2 Condensing Unit Operational Control..... 18
4.2.1 System Operation..... 18
4.2.1.1 Liquid Line Solenoid Control 18
4.2.1.2 Door Switch/Thermostat Control 18
4.2.2 Unit Functions..... 18
4.2.3 Controller Startup 18
4.2.4 Bump Start Control Operation 18
4.2.5 Compressor Stop Program..... 19
4.2.6 Low ambient operation 19
4.3 Component Controls..... 19
4.3.1 Suction Pressure Control..... 19
4.3.2 Crankcase Heater..... 19
4.3.3 Fan Control 19
4.3.4 Fan Overrides and Error Handling 20
4.3.5 Defrost Functionality 20
4.3.5.1 Holiday Defrosts 20
4.3.6 Enhanced Vapor Injection (EVI) 20
4.3.6.1 Low Temp EVI Discharge Line. Temperature Protection Mode (2HP-6HP)..... 20
4.3.6.2 Low Temp EVI (2HP-6HP) Discharge Line Temperature Protection Error Handling 20
4.3.6.3 EVI System Checks (XFAL 2HP-6 HP units only) 21
4.3.6.4 Constant Liquid Temperature Mode. For Low Ambient EVI Injection (2HP-6HP) 21
4.3.6.5 Low Temperature Units With EVI TXV Selection 21
4.3.6.6 Low Temperature Units with DTC Protection 21
4.3.7 Medium Temperature DLT Protection 21
4.3.7.1 Medium Temperature DLT Protection Error Handling..... 22
4.3.8 Low Temperature Small Scroll DLT Protection..... 22
4.3.9 Over-Current Protection 22
4.3.10 Incorrect Phase Sequence Protection (3 Phase Only)..... 22
4.3.11 Loss of Phase Protection - Current (3 Phase Only)..... 22
4.3.12 Open Run Circuit (Single Phase Only)..... 22
4.3.13 Open Start Circuit (Single Phase Only)..... 22
4.3.14 Over/ Under Voltage Protection 23
4.3.15 Compressor Internal Thermal Protection ...23

| | |
|---|---|
| <p>4.3.16 Fixed High Pressure Control 23</p> <p>4.3.17 Alarm Contact 23</p> <p>4.3.18 Anti-Flood Back Warning 23</p> <p>4.3.19 High Condensing Temperature Warning ... 23</p> <p>4.4 Local and Remote Displays and Communication 23</p> <p>4.4.1 Remote Display 23</p> <p>4.4.2 PC Connection 23</p> <p>4.4.3 Supervisory controls 23</p> | <p>4.5 Control Module Overview24</p> <p>4.6 Wire Diagrams29</p> <p>5 Troubleshooting39</p> <p>5.1 Manual Stepper Control Mode for Vapor Injection (Low Temp) or Liquid Injection (Medium Temp)39</p> <p>5.2 Alarm Codes39</p> <p>5.3 Sensor Values42</p> |
|---|---|

APPENDIXES

- [Appendix A: XCM25D Network Setup on E2 Controller](#)
- [Appendix B: 2017ECT-8 R1 FORM, DTC Valve Installation Instructions](#)
- [Appendix C: X-Line Service Parts](#)
- [Appendix D: Quick Setup Guide](#)

TABLE OF FIGURES

| | |
|---|--|
| <p>Figure 1 - Electrical Connections 7</p> <p>Figure 2 - Unit dimensions and clearance requirements 7</p> <p>Figure 3 - Typical Unit Cooler 9</p> <p>Figure 4 - Buttons Functions 11</p> <p>Figure 5 - Real Time Clock Setting 11</p> <p>Figure 6 - Pressure Controls Settings 11</p> | <p>Figure 7 - Defrost Setting 12</p> <p>Figure 8 - Unit Display 13</p> <p>Figure 9 - Defrost Button Position 20</p> <p>Figure 10 - Controller 24</p> |
|---|--|

TABLES

| | |
|--|--|
| <p>Table 1 - Specifications 6</p> <p>Table 2 - Nomenclature 6</p> <p>Table 3 - Electrical Data and Receiver Volume 8</p> <p>Table 4 - Refrigerant Liquid Temperature Valve Capacity Multiplier Correction Factors 10</p> <p>Table 5 - Default Settings 10</p> <p>Table 6 - Clock Parameters 11</p> <p>Table 7 - Refrigerant List 12</p> <p>Table 8 - Defrost Parameters 12</p> | <p>Table 9 - LED Functions 14</p> <p>Table 10 - List of Fast Access Parameters 16</p> <p>Table 11 - Alarm Button Functions 17</p> <p>Table 12 - High Voltage Connections 25</p> <p>Table 13 - Sensor Connections 25</p> <p>Table 14 - Other Connections 26</p> <p>Table 15 - Parameter List 26</p> |
|--|--|



Scan to watch an overview
video of an installation

Revision tracking R2

Pg. 6 – “Electrical Connections” Section Added.

Pg. 7 – Models added on Table 3: Electrical Data and Receiver Volume.

Pg. 11 – Low Ambient, Low Pressure Control Operations Section added.

Pg. 19 – Section added: Door Switch/Thermostat Control

Pg. 20 – Differential between the vapor inlet temperature and the vapor outlet temperature established in 18°F for all approved refrigerants

Pg 22 – Section added: Low Temperature Units with DTC Protection

Pg, 23 – Section added: Low Temperature Small Scroll DLT Protection

Pg. 38 – Alarm codes 8 and 42 deleted from Alarm codes list.

Pg. 26 – D13 Cable and functionality added in Sensor Connections chart.

Pg. 29 – tLS added to Parameter List.

Pg. 29 – 39 – Connections Drawings updated.

Safety Instructions

Copeland Scroll™ compressors are manufactured according to the latest U.S. and European Safety Standards. Particular emphasis has been placed on the user's safety. Safety icons are explained below and safety instructions applicable to the products in this bulletin are grouped on Page 3. These instructions should be retained throughout the lifetime of the compressor. **You are strongly advised to follow these safety instructions.**

Safety Icon Explanation



DANGER indicates a hazardous situation which, if not avoided, will result in death or serious injury.



WARNING indicates a hazardous situation which, if not avoided, could result in death or serious injury.



CAUTION, used with the safety alert symbol, indicates a hazardous situation which, if not avoided, could result in minor or moderate injury.



NOTICE is used to address practices not related to personal injury.







CAUTION, without the safety alert symbol, is used to address practices not related to personal injury.



FLAMMABLE, Fire hazard! Sparking in a potentially explosive atmosphere! Explosion hazard!

Instructions Pertaining to Risk of Electrical Shock, Fire, or Injury to Persons

| | |
|---|--|
|  | <p>ELECTRICAL SHOCK HAZARD</p> <ul style="list-style-type: none"> • Disconnect and lock out power before servicing. • Discharge all capacitors before servicing. • Use compressor with grounded system only. • Molded electrical plug must be used when required. • Refer to original equipment wiring diagrams. • Electrical connections must be made by qualified electrical personnel. • Failure to follow these warnings could result in serious personal injury. |
|  | <p>PRESSURIZED SYSTEM HAZARD</p> <ul style="list-style-type: none"> • System contains refrigerant and oil under pressure. • Remove refrigerant from both the high and low compressor side before removing compressor. • Never install a system and leave it unattended when it has no charge, a holding charge, or with the service valves closed without electrically locking out the system. • Use only approved refrigerants and refrigeration oils. • Personal safety equipment must be used. • Failure to follow these warnings could result in serious personal injury. |
|  | <p>BURN HAZARD</p> <ul style="list-style-type: none"> • Do not touch the compressor until it has cooled down. • Ensure that materials and wiring do not touch high temperature areas of the compressor. • Use caution when brazing system components. • Personal safety equipment must be used. • Failure to follow these warnings could result in serious personal injury or property damage. |
|  | <p>COMPRESSOR HANDLING</p> <ul style="list-style-type: none"> • Use the appropriate lifting devices to move compressors. • Personal safety equipment must be used. • Failure to follow these warnings could result in personal injury or property damage. |

Safety Statements

- Refrigerant compressors must be employed only for their intended use.
- Only qualified and authorized HVACR personnel are permitted to install commission and maintain this equipment.
- Electrical connections must be made by qualified electrical personnel.
- All valid standards and codes for installing, servicing, and maintaining electrical and refrigeration equipment must be observed.

1 Introduction

Copeland Scroll™ Outdoor Refrigeration Units provide the benefits of scroll compressor technology, coupled with advanced diagnostic controls, to ensure reliable performance and operation in foodservice applications.

Units are available in 0.75 to 6 HP. All units are 208/230 volts and are available in single or three phase. All units come factory equipped with a heated and insulated receiver, service valves, pressure controls, defrost control, filter drier, moisture indicator, crankcase heater, variable speed condenser fan, CoreSense™ Protection and Diagnostics, and two-way communications standard.

An integrated electronic control module (Dixell XCM25D) provides operation, protection, and diagnostic features for the unit. The Dixell XCM25D Electronic Control Module with CoreSense™ technology (control module) on Copeland™ condensing units provides many benefits to the contractor and end-user. It is designed specifically for demanding refrigeration applications to ensure simple installation and precision operation. While the control module replaces mechanical adjustable low-pressure controls, fan cycle switches and other relays, it also has additional features. These features include bump start,

data storage, communication, and short cycling protection.

2 Inspection

Inspect unit for shipping damage. Immediately report any damage to the carrier. Check the unit nameplate to verify that the model number is correct for the application. Read all compressor and condensing unit warning labels.

3 Installation

A qualified refrigeration technician must install this system.

Table 1 - Specifications

| | |
|-------------------------------|------------------------|
| Operating Ambient Temperature | -40°F – 120°F |
| Supply Voltage | 187-253 VAC |
| Sound Level | 53-55 dBa (Single fan) |
| | 58-59 dBa (Dual fan) |

Table 2 - Nomenclature

| | | | | | | | | | | |
|-------------|-----------------------|----------------|--|----------|---|-----------------------|------------|--|----------|------------------|
| X | F | A | M | - | 0 2 0 | Z | - | T F C | - | 0 8 1 |
| X = Outdoor | F = Multi-Refrigerant | A = Air Cooled | L = Low Temp M = Medium Temp. P = Multi- Application | | Nominal HP: 008 = ¾ HP 015 = 1.5 HP 060 = 6 HP | Z = Scroll Compressor | | CFV = 208/230v 1Ph. 60 Hz. TFC = 208/230v 3Ph. 60 Hz. | | Bill of Material |
| Base Model | | | | | | | Electrical | | BOM | |

3.1.1 Mounting Location

This unit can mount on the ground, roof, or on a wall. For ground mounting, place the unit on a level solid concrete slab with rubber strips between the feet and concrete, or on a suitable raised support structure (PN 074-7289-00).

For wall mounting, use a wall bracket system designed for mounting condensing units (PN 074-7286-00) or universal metal framing strut and follow the manufacturer's instructions. Follow local zoning and building codes for all mounting options.

Maintain 8 inches clearance on the unit's left and rear sides for air intake. Maintain 20 inches clearance on the unit's right, top and front panels for airflow and service access. (See **Figure 2**). Ensure that discharge air from one unit does not circulate to another unit.

3.1.2 Piping

Pipes must be sized for proper performance, and oil return. Follow ASHRAE guidelines for proper piping practices.

3.2 Electrical Connections

These units use spring cage type terminals for all electrical connections. Field power connections are labeled L1, L2, L3 (on three phase only), and G

(ground). Defrost connections are labeled 3, 4, X, and N to match labeling on most unit coolers. Terminals will accept up to #8 AWG wire for main power and #10 AWG for defrost connections. Wire sizes must be suitable for the Minimum Circuit Ampacity (MCA) of the unit. See **Table 3** for MCA values of each unit.

Strip wire insulation back to expose 1/2 inch bare wire. Firmly insert a small screwdriver into the square opening to open the spring cage. Insert the wire into the round opening and remove the screwdriver (see **Figure 1 - Electrical Connections**).

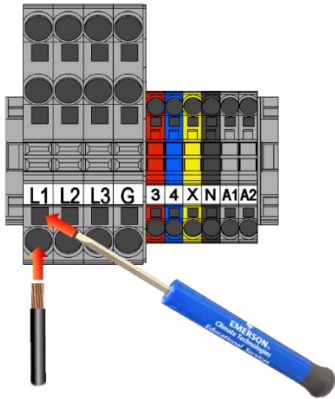

Figure 1 - Electrical Connections

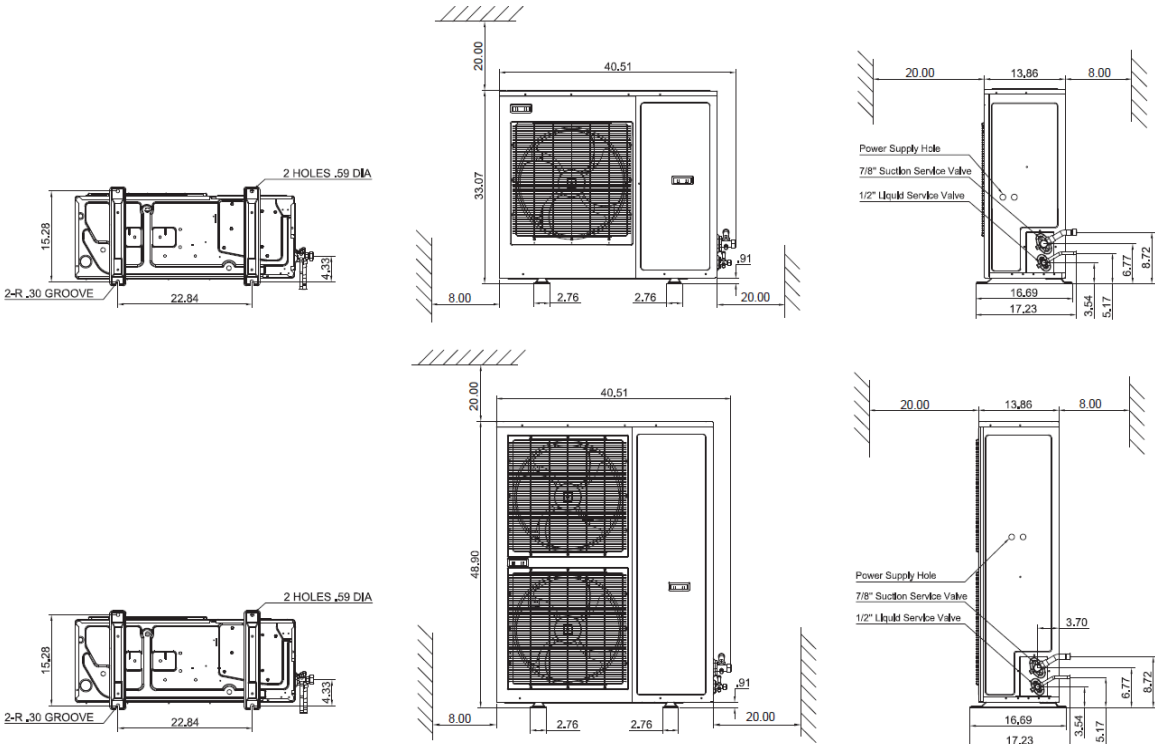

Figure 2 - Unit dimensions and clearance requirements

3.3 Evaporator connections and considerations

The X-Line unit can connect with any electric defrost or air defrost evaporator. Most evaporators will connect to the X-Line unit using the typical wiring of any other unit. Some newer evaporators with built in electronic controls may require some adjustments to parameter settings to avoid conflicts or false alarms. Evaporators with stand-alone power and controls do not need any connection to the X-Line unit. The unit will cycle based on suction pressure cut-in/cut-out.

If a situation occurs non-standard of a typical evaporator installation that could possibly require a communication link to the X line unit, contact the evaporator manufacturer for additional information in order to disable that requirement.

3.3.1 Evaporators with built-in Time Delay

Evaporators with a non-adjustable built – in time delay function will require a Time Delay adjustment on the X Line unit to avoid operational issues. Parameter τ_{DF} should be coordinated with the evaporator manufacturer for proper operation.

3.3.2 Evaporators with built-in defrost controls

The connected evaporator has built-in defrost control, or if a third party defrost control is used, set the defrost mode on the X-Line unit (Parameter EdF) to nU (off).

3.3.3 Evaporators with electronic expansion valves (EXV)

If the evaporator has an electronic expansion valve and control, additional energy savings are possible by adjusting the minimum condensing temperature (Parameter τ_{CS}) of the X-Line unit. See **Low Condensing** on **pg. 13** for more information.

3.3.4 Superheat Requirements

In order to assure that liquid refrigerant does not return to the compressor during the running cycle, attention must be given to maintaining proper superheat at the compressor suction inlet. Emerson recommends a minimum of 20°F (11°C) superheat, measured on the suction line 6 inches (152mm) from the suction valve, to prevent liquid refrigerant floodback.

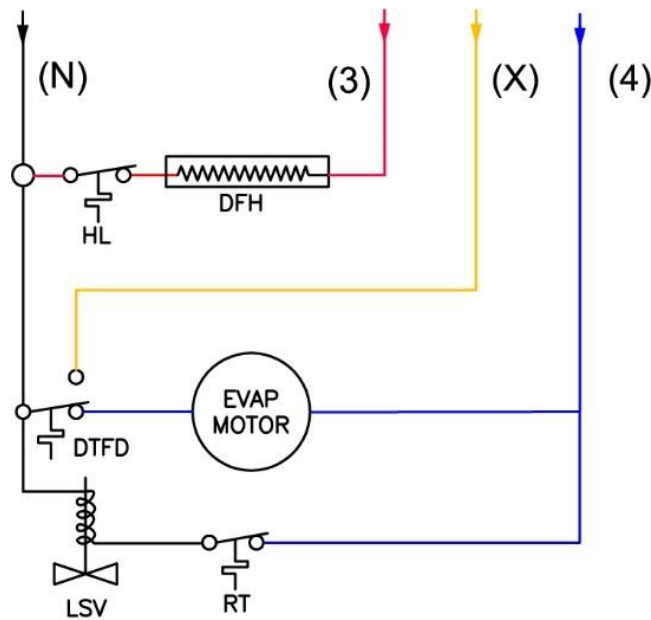

Figure 3 - Typical Unit Cooler

Table 4 - Refrigerant Liquid Temperature Valve Capacity Multiplier Correction Factors

| | Refrigerant Liquid Temperature Entering TXV | | | | | | | | | | | | | | |
|---------------|---|------|------|------|------|------|------|------|------|------|------|------|------|------|------|
| | 0 | 10 | 20 | 30 | 40 | 50 | 60 | 70 | 80 | 90 | 100 | 110 | 120 | 130 | 140 |
| R-22 | 1.56 | 1.51 | 1.45 | 1.40 | 1.34 | 1.29 | 1.23 | 1.17 | 1.12 | 1.06 | 1.00 | 0.94 | 0.88 | 0.82 | 0.76 |
| R-404A | 2.00 | 1.90 | 1.80 | 1.70 | 1.60 | 1.50 | 1.40 | 1.30 | 1.20 | 1.10 | 1.00 | 0.90 | 0.80 | 0.70 | 0.50 |
| R-507 | 2.00 | 1.90 | 1.80 | 1.70 | 1.60 | 1.50 | 1.40 | 1.30 | 1.20 | 1.10 | 1.00 | 0.90 | 0.80 | 0.70 | 0.50 |
| R-134a | 1.70 | 1.63 | 1.56 | 1.49 | 1.42 | 1.36 | 1.29 | 1.21 | 1.14 | 1.07 | 1.00 | 0.93 | 0.85 | 0.78 | 0.71 |
| R-407A | 1.75 | 1.68 | 1.61 | 1.53 | 1.46 | 1.39 | 1.31 | 1.24 | 1.16 | 1.08 | 1.00 | 0.92 | 0.84 | 0.76 | 0.68 |
| R-407C | 1.69 | 1.62 | 1.55 | 1.49 | 1.42 | 1.35 | 1.28 | 1.21 | 1.14 | 1.07 | 1.00 | 0.93 | 0.86 | 0.79 | 0.72 |

These factors include corrections for liquid refrigerant density and net refrigerating effect and are based on an average evaporator temperature of 0°F. However, they may be used for any evaporator temperature from - 40°F to + 40°F since the variation in the actual factors across this range is insignificant.

3.4 Leak Check and Refrigerant Charging

Units are shipped with a dry air holding charge (11 lb.). Open the service valves to release the charge. Make sure the inside of copper tubes are clean before brazing line connections. Use a dry nitrogen bleed during brazing. Charging ports are provided on the liquid and suction service valves. Service valves should not be open to atmosphere longer than 15 minutes. Compressors with POE (polyolester) oil will quickly become contaminated when opened to atmosphere.

Pressurize the system to 185 PSIG with an approved pressure source to leak check. Use a leak detection solution or electronic leak detector following the manufacturer’s directions.

Evacuate system, then charge with the desired refrigerant.

3.5 Initial Startup

Copeland Scroll™ Outdoor Refrigeration Units are equipped with the latest in unit control and protection technology. When power is first applied, the unit will perform a series of diagnostic checks and protective actions.

3.5.1 Incorrect Phase Sequence Protection

On three-phase units, if an incorrect phase (L1, L2, L3) is detected, the control will prevent the compressor from starting and will display code L21. To correct, disconnect power and swap the L1 and L2 wires. The unit will start when power is reapplied.

3.5.2 Flooded start protection (Bump Start)

On initial startup, the compressor will cycle through a series of 3 short start and stops. The compressor will cycle on for 2 seconds, then off for 15 seconds. This process protects against flooded starts, and occurs any time power is lost and reapplied to the unit, or any time the unit is off for more than 4 hours and the ambient temperature is below 95°F.

3.5.3 Default Settings

The built-in control module comes factory set with default settings that allow the unit to run with commonly used settings (see **Table 5 - Default Settings**). No adjustments are needed during the initial startup and charging of the system. Adjustments can be made after the system is fully charged and operating.

Table 5 - Default Settings

| Variable | Default Setting |
|-------------------------------------|---|
| Refrigerant | R-404A |
| Med. Temp. Suction Cut-In Pressure | 25 psi |
| Med. Temp. Suction Cut-Out Pressure | 15 psi |
| Low Temp. Suction Cut-In Pressure | 20 psi |
| Low Temp. Suction Cut-Out Pressure | 7 psi |
| Defrost Settings | Every 8 hours, 45-minute maximum duration |

3.6 Main Settings

The default settings will allow the system to operate at a basic level. If R-404A refrigerant is used in the system, the unit can continue to operate with no additional settings adjustments. However, to take advantage of the on-board diagnostics, to optimize operation, or if a refrigerant other than R-404A is used, additional settings must be adjusted.

See **Appendix D** for a Quick Setup Guide

3.6.1 How to Adjust Settings

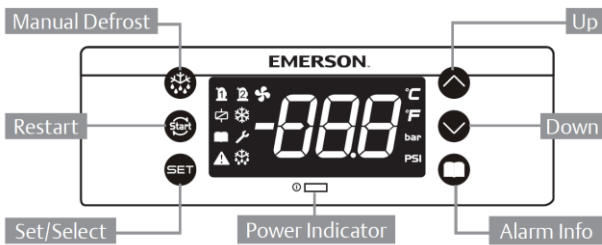

Figure 4 - Buttons Functions

1. Hold “SET” and “Down” for 3 seconds to enter programming mode.
2. Use “Up” and “Down” to cycle through settings and adjust values.
3. Use “Set” to select and accept settings.
4. Hold “SET” and “Up” to exit programming mode or wait 60 seconds for programming mode to time out.

3.6.2 Real Time Clock

The real-time clock is used to time and date stamp all errors and alarms in the on-board data log. It also allows a time-of-day based defrost schedule and a holiday defrost schedule.

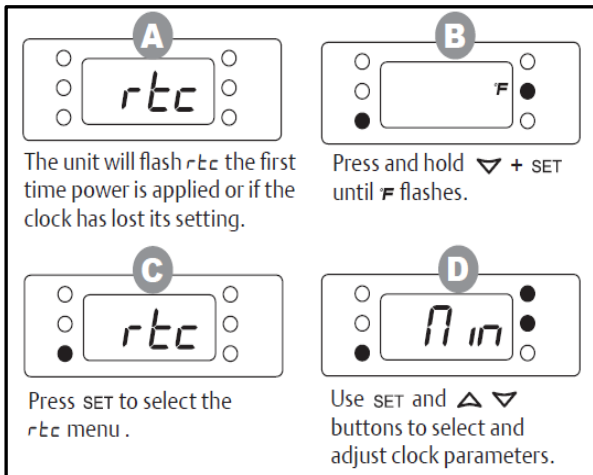

Figure 5 - Real Time Clock Setting

Table 6 - Clock Parameters

| Par. | Description | Value Range |
|------------|-------------|-------------|
| <i>min</i> | Minute | 0 - 59 |
| <i>Hr</i> | Hour | 0 - 23 |
| <i>day</i> | Day | 1 - 31 |
| <i>mon</i> | Moth | 1 - 21 |
| <i>YEr</i> | Year | 0 - 99 |



Scan to watch a video on how to set the clock.

3.6.3 Low Ambient, Low Pressure Control Operations

In the event if extreme low ambient conditions are present, there is an adjustment which is available in the advanced options menu to adjust the low pressure control minimum on time as well as initiation temperature. See Parameter menu in **Section 4.2.6, Pg. 19**

3.6.4 Refrigerant and Pressure Control Settings

The correct refrigerant must be set to match what is installed in the system. This setting adjusts the values the control uses to decide if the unit is operating correctly and within set limits. Failure to set the refrigerant to match the refrigerant used can result in inefficient operation, and false alarms. The pressure control cut-in and cut-out set points should also be set for the specific application.

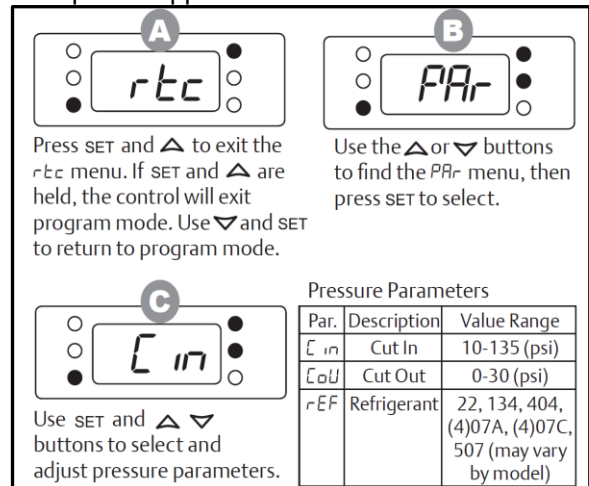

Figure 6 - Pressure Controls Settings

Table 7 - Refrigerant List

| Refrigerant | rEF Display |
|-------------|-------------|
| R-404A | 404 |
| R-507 | 507 |
| R-134A | 134 |
| R-22 | r22 |
| R-407C | 07C |
| R-407A | 07A |
| R-407F | 07F |
| R-448A | 48A |
| R-449A | 49A |



Scan to watch a video on how to set the setpoints.

3.6.5 Defrost Mode Selection

The control module is capable of direct control of air defrost or electric defrost on single phase evaporators with up to 30-amp heaters. An additional contactor is required for use with three phase heaters. If the connected evaporator has built-in defrost control, or if a third party defrost control is used, set the defrost mode (EdF) to nU (off).

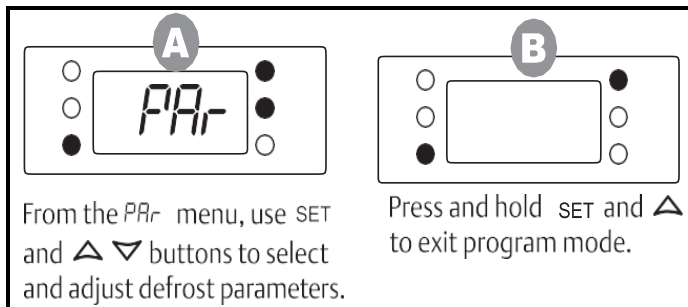

Figure 7 - Defrost Setting

Table 8 - Defrost Parameters

| Par. | Description | Value Range |
|------|--------------------------|--------------------------------------|
| idF | Interval between defrost | 0 – 120 (hours) |
| ridF | Max duration | 0 – 255 (minutes) |
| EdF | Defrost mode | nU (off), in (interval), rEc (clock) |
| LD1 | 1st start time | nU (not used), 0 - 23:50 |
| LD2 | 2nd start time | |
| LD3 | 3rd start time | |
| LD4 | 4th start time | |
| LD5 | 5th start time | |
| LD6 | 6th start time | |



Scan to watch a video on how to set the defrost mode.

3.7 Advanced Settings

Several optional settings are provided to allow customization for specific application needs.

To access the advanced settings, select the PAS (password) parameter from the PAR menu. Enter code “321” using the “Up” and “Down” buttons to adjust the value, and the “Set” button to accept the value.

3.7.1 Auto / Manual Restart

Compressor lockouts activate when conditions cause repeated compressor shutdowns. Default settings allow either 4 or 5 auto restarts (depending on cause). These settings can be changed to disable auto restarts, disable lockouts, or change the number of shutdowns allowed before a lockout occurs. The compressor safety and compressor protection sections of **Table 15** shows the lockout parameters that can be adjusted.

3.7.2 Anti-short cycle control

A minimum compressor off time is set to 120 seconds to prevent short-cycling and protect against compressor reverse rotation that can result from brief power interruptions on single phase systems. Some newer evaporator controls also include short-cycle protection. To avoid potential conflicts between two controls, the minimum compressor off time can be adjusted by changing parameter rOF. Changing the value to 20 seconds will avoid conflicts with evaporator controls.

3.7.3 Low Condensing Operation

The unit is factory set with a default minimum condensing value of 70°F (80°F for XFAL). To fully utilize low condensing options below 70°F condensing, an electronic expansion valve (EXV) is normally required to handle the larger variation in mass flows. If a system EXV is installed, the minimum condensing value can be lowered by changing parameter $L\bar{C}5$ in the advanced options menu. The system will monitor operating conditions and automatically adjust the minimum condensing value if the compressor operating envelope would be exceeded.

3.7.4 Low Ambient Operation

The condensing unit can operate in outdoor ambient temperatures as low as -40°F. The unit will automatically adjust condenser fan speed to maintain head pressure. At extremely low ambient temperature the condenser fan might not run, but the condenser coil is still discharging heat. Parameter $L\bar{A}5$ sets the ambient temperature required to initiate low pressure control bypass time delay. The default value is -20°F. Parameter $L\bar{A}0$ sets the low ambient minimum on time. The default value is 6 seconds. Below -20°F ambient, when the condensing unit starts it will run for a minimum of 6 seconds even if the suction pressure drops below the cut-out set point.

4 Use and Operation

4.1 User Interface

The controller display is shown below along with the function of each light. The controller displays the current suction pressure to three digits in pounds per square inch gage (psig). The controller uses a 7-segment display for digits and the following alpha characters:









The 7-segment alphabet and Roman equivalent:

| | | | | | | | | | | | | | | | | | | | | | | | | | | | | |
|---|---|---|---|---|---|---|---|---|---|---|---|---|---|---|---|---|---|---|---|---|---|---|---|---|---|---|---|---|
| A | b | C | d | E | F | H | i | L | ñ | n | o | P | q | r | S | t | U | Y | 0 | 1 | 2 | 3 | 4 | 5 | 6 | 7 | 8 | 9 |
| A | B | C | D | E | F | H | I | L | M | n | o | P | q | r | S | T | U | Y | 0 | 1 | 2 | 3 | 4 | 5 | 6 | 7 | 8 | 9 |











Figure 8 - Unit Display

Table 9 - LED Functions







| LED | MODE | FUNCTION |
|--|----------|---|
|  | ON | Compressor enabled |
| | Flashing | Anti-short cycle delay enabled |
|  | ON | Condensing fans enabled |
|  | ON | Display temperature value in degrees F |
| | Flashing | Programming mode |
|  | ON | Display pressure value in PSI |
|  | ON | Browsing service menu |
| | Flashing | Fast access menu (Viewing set points and measured values) |
|  | ON | Browsing the alarm menu |
| | Flashing | New alarm occurred |
|  | ON | An alarm is occurring |
|  | ON | In defrost or evap fan drip time when ON |
|  | ON | Evaporator fans enabled |

4.1.1 Button Descriptions and Key Combinations

| | |
|---|--|
|  | (SET) Select a parameter or confirm an operation when in programming mode. |
|  | (RESTART) Hold for 5 seconds to reset any lockouts if the current state of the controller allows for reset. Allows a manual restart and a “dead band reset”. |
|  | (UP) View current measured values (Fast Access Menu); in programming mode or any menu to browse the parameter codes or increase the displayed value. |
|  | (DOWN) in programming mode or any menu to browse the parameter codes or decrease the displayed value. |
|  | (SERVICE) To enter the service and alarm menu. |
|  | Hold for 3 seconds to start a manual defrost |
|  | Press and hold for about 3 sec to lock (P_{on}) or unlock (P_{oF}) the keyboard. |
|  | Press together to exit from programming mode or from menu; on submenus to return to previous level. |
|  | Press together for 3 sec to access to first level of programming mode. |

4.1.2 Changing a Parameter Value

To change a parameter value:







1. Hold down SET +  keys for 3 seconds or until the 'F' LED starts blinking to enter the module's programming menu.
2. Use  or  to select the *rEL* or *PRr* menu
3. Press SET to enter the menu.
4. Use  or  to select the required parameter.
5. Press the SET key to display its value.
6. Use  or  to change its value.
7. Press SET to store the new value.

TO EXIT: Press SET +  or wait 60 seconds without pressing a key.

NOTE: The set value is stored even when the procedure is exited by waiting for the time-out to expire.

NOTE: If a menu does not have any parameters available, *noP* will be displayed

4.1.3 Entering the Advanced Options Menu

1. Hold down SET +  keys for 3 seconds or until the F LED starts blinking to enter the module's programming menu.
2. Use  or  to select the *PRr* menu
3. Press SET to enter the menu
4. Use  or  to select the *PAS* parameter
5. Press SET to select *PAS*
6. The blinking *PAS* label will be showed for a few seconds
7. Will be showed  - - with blinking : insert the password [321] using the keys UP and DOWN and confirming with SET key.

4.1.4 Moving Parameters Between the Programming Menu and the Advanced Options Menu

While in the advanced options menu, certain parameters will have a (.period) in between the 2nd and 3rd character, for example *EL.n*. These parameters are in the Programming Menu as well as the Advanced Options Menu.

To add or remove a parameter from the programming menu, press the SET +  keys together while the parameter name is on the display in the advanced options menu. The (. period) between the 2nd and 3rd parameter will either be added or removed.

TO EXIT: Press SET +  or wait 60 seconds without pressing the keys.



4.1.5 Locking the Keypad

Press the  +  keys for 3 seconds.

The *PDF* message will be displayed and the keyboard will be locked. The Fast Access Menu will remain accessible while the keyboard is locked.

If a key is pressed more than 3 seconds the *PDF* message will be displayed.

4.1.6 Unlocking the Keypad

Press the  +  keys for 3 seconds until the *Pon* message is displayed.

4.1.7 Fast Access Menu

This menu allows viewing measured values from various probes and view some outputs resulting from these measurements. The values *noP* or *noP* stand for probe not present or value not evaluated. *Err* means the value is out of range, probe is damaged, not connected, or incorrectly configured.

Press to enter the Fast Access Menu.

Use up or down arrows to select an entry, then press set to see the value or to go on with other value.

TO EXIT: Press or wait 60 seconds without pressing the keys.







Table 10 - List of Fast Access Parameters

| | | |
|-------------|-----|---|
| <i>P 1P</i> | P1P | Suction pressure |
| <i>P2t</i> | P2t | Condenser temperature |
| <i>P2P</i> | P2P | Not Used |
| <i>P3t</i> | P3t | Discharge line temperature |
| <i>P4t</i> | P4t | EVI heat exchanger vapor inlet temperature (XFAL 2HP-6HP only) |
| <i>P5t</i> | PSt | EVI heat exchanger vapor outlet temperature (XFAL 2HP-6HP only) |
| <i>P6t</i> | P6t | Ambient temperature |
| <i>P7t</i> | P7t | Liquid line temperature (XFAL 2HP-6HP only) |
| <i>5H</i> | 5H | Not used |
| <i>oPP</i> | oPP | Percentage of liquid injection (XFAP/XFAM) or vapor injection (XFAL 2HP-6HP) valve opening. |
| <i>LLS</i> | LLS | Not used |
| <i>Std</i> | Std | Current condenser temperature target for fan speed control |
| <i>A00</i> | A00 | Fan speed percent |
| <i>d5o</i> | d5o | Not used |
| <i>L t</i> | L t | Not used |
| <i>H t</i> | H t | Not used |
| <i>tU1</i> | tU1 | Line voltage (1-phase) |
| <i>tU2</i> | tU2 | Line voltage (3-phase) |
| <i>tU3</i> | tU3 | Line voltage (3-phase) |
| <i>tA1</i> | tA1 | Current (1-phase) |
| <i>tA2</i> | tA2 | Current (3-phase) |
| <i>tA3</i> | tA3 | Current (3-phase) |
| <i>HM</i> | HM | Menu |

4.1.8 Alarm Menu

The controller time-stamps and stores the last 50 alarms. See Section 11 for alarm codes.

Table 11 - Alarm Button Functions

| Action | Button | Notes |
|---|--|---|
| Enter alarm menu |  | Push and release alarm key (Displays SEC when alarm menu is active) |
| Enter alarm list | SET | Press SET to confirm |
| Scroll through active and recorded alarm list |  Or  | Scroll the list of alarms and see the list of active alarms with the number of the alarm (Letter + Number, A01-A50). Push Down key and see the alarm Name or Code. Push Down key and see the next active alarm |
| Select the alarm to see the date and time | SET | Enter the sub menu with alarm time details |
| Scroll through alarm information data |  Or  | Successive presses of the down arrow button will display the clock data label (hour, minute, day, month, year) followed by the value of the preceding label. The up arrow will reverse this order and show the value followed by the label. The displayed values record the start time of an alarm. |
| Exit menu | SET +  | Press SET and UP together or wait about 10 seconds. |

4.1.9 How to Program a HOT-KEY from the Controller (UPLOAD TO OVERWRITE HOT-KEY)

Caution: Overwrites hot key. When the controller is ON, insert the HOT-KEY into the 5-PIN receptacle (labeled H-K) and push the  button; the *UPL* message appears followed a by a flashing *End* label.

Push SET button and the *End* will stop flashing.

Turn OFF the controller, remove the HOT-KEY and then turn the controller ON again.

NOTE: the *Err* message appears in case of a failed programming operation. In this case push the  again if you want to restart the upload again or remove the HOT-KEY to abort the operation.

4.1.10 How to Program a Controller Using a HOT-KEY (Download)

A hot key is included with each unit for factory reset and replacement control programming. Remove power from the unit.

Insert a pre-programmed HOT-KEY into the 5-PIN receptacle (labeled H-K) and reapply power to the unit.

The parameter list of the HOT-KEY will be automatically downloaded into the controller memory. The *daL* message will blink followed by a flashing *End* label.

After 10 seconds the controller will restart and begin working with the new parameters.

Remove the HOT-KEY

NOTE: The message *Err* is displayed for failed programming. In this case turn the unit off and then on if you want to restart the download again or remove the HOT-KEY to abort the operation

4.2 Condensing Unit Operational Control

4.2.1 System Operation

4.2.1.1 Liquid Line Solenoid Control

By default, the unit assumes that a liquid line solenoid is used to pump down the system during a defrost. When the unit enters a defrost, the evaporator power (Connection 3 on the terminal strip) will be turned off, turning off the liquid line solenoid as well. The unit will then run until the suction pressure drops below the cut-out value, then turn off the compressor. When the defrost is complete, the unit will apply power to the evaporator, opening the solenoid and the compressor will start running once the suction pressure is above the cut in.

If a pump down solenoid is not present or the unit should not pump down when entering a defrost, parameter **EL5** should be set to no. **EL5** is set to **YES** by default.

4.2.1.2 Door Switch/Thermostat Control

Kit Number 929-0220-16 can be used to connect to the device. Digital Input 3 (DI3 on the XCM25D) can be used as a door switch or a thermostatic On-Off control. In order to use DI3 for this purpose, technician must enter the Advanced Options Menu and adjust parameter i3P to OP. For instructions on adjusting this parameter, please see the sections on “**Entering the Advanced Options Menu**” and “**Changing a Parameter Value**” in this bulletin. After this occurs, condensing Unit will run when Switch/Thermostat is in the closed position and will be Off when the switch/Thermostat is open.

Please, note there is a warning (E66) programmed into the XCM25D if the door is open or thermostat does not call for cooling for longer than 255 consecutive minutes.

4.2.2 Unit Functions

The X-Line control module operates the condensing unit and ensures the system remains in correct operating conditions. It controls the follow items:

- Compressor
- Condenser Fan Motor(s)
- Crank Case Heater
- Receiver Heater
- Defrost Heater (If connected)

The X-line Unit will protect the system from the following fault conditions (See Sections 6.23 through 6.31 for further details):

Discharge Line Temperature Protection
Over-Current Protection

Incorrect Phase Sequence Protection (3 Phase Only)

Loss of Phase Protection - Current (3 Phase Only)

Open Run Circuit (Single Phase Only)

Open Start Circuit (Single Phase Only)

Over/ Under Voltage Protection

Phase Imbalance (3 Phase Only)

Compressor Internal Thermal Protection

Fixed High Pressure Control

In addition, the X-Line unit has protection features that will prevent it from reaching a fault condition. For example, when the low temperature unit experiences an extremely hot day, the control module decides to switch from vapor-injection-optimization to discharge gas temperature control to allow the compressor to run safely and pass the extreme weather hours.

4.2.3 Controller Startup

At initial power up, the controller display will display the following information:

All LEDs will light up for approximately 2 seconds.

For 3 seconds, the controller will display the firmware version (EX: 1.0, 1.1, etc.)

For three seconds the controller will display the program number (EX: 100, 101, 200, etc.)

The controller will then wait 6 seconds before turning on the compressor or any other device.

Once the controller calls for the compressor to run and there are no active alarms, the controller will then turn on the compressor utilizing bump start (if needed per Section 6.15) and control the fans and compressor.

4.2.4 Bump Start Control Operation

If the ambient temperature sensor reads less than 95°F when the controller is first turned on or after the compressor has been off for 4 hours and now is being turned on, the compressor will initiate a bump start. If the ambient temperature sensor is not functioning, the mid-coil temperature sensor will determine if the unit will initiate a bump start or not.

The compressor and fans will run for 2 seconds then turn off for 15 seconds three times. Once this sequence is completed, the unit resumes normal operation.

The crank case heater will remain off during the bump start sequence.

If liquid injection, vapor injection, or a system EXV is present, the stepper valve will remain closed until the bump start has finished.

In the event of a power loss, the controller can be programmed to enter a defrost at power up if dP_a is set to YES . It is turned off by default but is adjustable from the advanced options menu.

4.2.5 Compressor Stop Program

When the compressor needs to turn off, either based on an error or loss of demand, the following items will occur:

- Liquid or Vapor Injection Only: If a non-error shutdown occurs, compressor runs for 5 seconds before turning off to allow the liquid of vapor injection valves to fully close.
- Compressor turns off
- Condenser fans turn off

Crankcase heater turned on (See **Section 4.3.2**)

NOTE: During the pump down process with the 5 second delay the compressor may run down into a vacuum. There are no reliability issues in this application.

4.2.6 Low ambient operation

The condensing unit can operate in outdoor ambient temperatures as low as -40°F . The unit will automatically adjust condenser fan speed to maintain head pressure. At extremely low ambient temperature the condenser fan might not run, but the condenser coil is still discharging heat. Parameter L_{AS} sets the ambient temperature required to initiate low pressure control bypass time delay. The default value is -20°F . Parameter L_{TD} sets the low ambient minimum on time. The default value is 6 seconds. Below -20°F ambient, when the condensing unit starts it will run for a minimum of 6 seconds even if the suction pressure drops below the cut-out set point.

IMPORTANT NOTE: To fully utilize low condensing options below 70°F condensing, an electronic expansion valve (EXV) is normally required to handle the larger variation in mass flows. See Section “**Low Condensing Operation**” for instructions about i_{CS} parameter settings.

4.3 Component Controls

4.3.1 Suction Pressure Control

The compressor is operated based on the suction pressure cut-in (L_{in}) and cut-out (L_{out}). If the suction pressure rises above the cut-in, the compressor is turned on using the startup procedure (See **Section 4.2.3**). If the suction pressure then falls below the cut-

out, it turns the compressor off using the shutdown procedure (See **Section 4.2.5**).

The compressor remains off for a minimum 120 seconds (L_{off}) after shutdown, which is adjustable in the advanced options menu (See **Section 3.7**).

If the suction pressure transducer fails, the compressor will run in limp along mode. The compressor will stay off for 3 minutes (L_{off}) then run for 3 minutes (L_{on}). These values are adjustable from the advanced options menu (See **Section 3.7**).

The cut-in and cut-out settings are adjustable between 0 PSIG and 135 PSIG.

IMPORTANT: At initial power up, depending on the suction pressure transducer, the suction pressure could be higher than the rating of the transducer. For 15 minutes after power up, any over pressure errors generated by the suction pressure transducer should be ignored, and the display will flash 135. If the transducer is still in an error state after the time has expired, the control will alarm that the suction pressure transducer signal is lost and go into limp along mode.

4.3.2 Crankcase Heater

The crankcase heater is energized when the ambient temperature is below 50°F and the compressor is off. If an ambient sensor fails, the crankcase heater is energized when the compressor is off.

4.3.3 Fan Control

The X-line uses variable speed PSC condenser fan motors to maintain the head pressure values that allow the system to operate within the compressor operating envelope and maintain the minimum pressure differential across the expansion device to allow it to operate properly.

The controller uses a Proportional-Integral (PI) control algorithm to determine the fan speed. The fans will not run any slower than 40% before turning off. When a fan first turns on it will run for 3 seconds at full speed before it begins modulating. Fans will run for at least 10 seconds before turning off and stay off for at least 10 seconds before being turned back on.

Since the X-Line controller knows the current suction pressure, the controller can determine the minimum condensing point for the condition the unit is actually running and will adjust the fan control set point to maintain that temperature or higher.

The XFAP/XFAM and XFAL models have different compressors and different refrigerant options. Therefore, during commissioning, it is important to identify the selected refrigerant, so the controller will operate the fans properly.

4.3.4 Fan Overrides and Error Handling

If the discharge line temperature is above 205°F the fans will run at full speed.

If the condenser mid-coil temperature sensor fails, the fan speed is determined by outdoor ambient. If both the outdoor ambient sensor and the condenser mid-coil temperature sensor fail, all fans will run at full speed.

4.3.5 Defrost Functionality

The control module is capable of direct control of air defrost or electric defrost on single phase evaporators with up to 30-amp heaters. An additional contactor is required for use with three phase heaters. Default settings are set to initiate a defrost every 8 hours with a maximum duration of 45 minutes. During a defrost the controller will display **dEF**.

To manually initiate a defrost, press and hold the defrost button for 3 seconds. The controller will terminate defrost after 45 minutes **̄idf** (**Pr I** parameter) or after the defrost termination input (Terminal 'X') is closed.

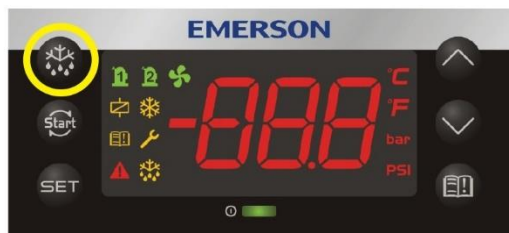

Figure 9 - Defrost Button Position

The defrost control can also operate on a time-of-day schedule (**rEc**) or disabled if needed (**nU**). Parameters **Ld1** through **Ld6** control the times when defrosts will initiate when using the rtc mode.

Defrost Parameter are depicted in **Table 8 - Defrost Parameters**.

4.3.5.1 Holiday Defrosts

If you are using real time clock mode (**rEc**), holiday defrosts can be set in the advanced options menu. To set a holiday, change **Hd1** from **nU** to whatever day of the week you would like to have a different defrost schedule. (An example would be if a store is closed on Sundays and needs less defrosts). You can set a second holiday by changing **Hd2**. The defrosts for the set holidays are controlled by parameters **5d1** through **5d6**.

4.3.6 Enhanced Vapor Injection (EVI) For Low Temperature Units (2HP-6HP)

The injection valve is a key part of the EVI system. It regulates vapor injection flow to optimize the performance of system and cool the scroll set. When the compressor first calls for power, the injection valve opens a preset amount before the compressor turns on. After startup, the EVI injection valve is controlled using a proportional-integral (PI) algorithm to control the differential between the vapor inlet temperature and the vapor outlet temperature. The differential is 18°F for all approved refrigerants. The PI algorithm for the EVI injection valve control is auto-adaptive, so it does not need to be adjusted.

4.3.6.1 Low Temp EVI Discharge Line. Temperature Protection Mode (2HP-6HP)

If during normal operation the DLT temperature reaches 225°F the control changes to act as a liquid injection valve to control the DLT temperature. Once the DLT temperature falls below 200°F, normal vapor injection control resumes.

If the discharge temperature goes above 250°F, the compressor trips off and the control displays an **E44** error. The compressor cannot turn back on until the temperature drops below 170°F and has been off for 3 minutes.

If the compressor trips more than 4 times per hour (**dLn**), the controller will lock out the compressor, requiring a manual reset or the controller power to be reset. The controller will display **L44** showing the compressor has tripped on high DLT and locked out. If parameter **dLn**, which is available in the advanced options menu, is set to 0, the unit will always automatically reset.

4.3.6.2 Low Temp EVI (2HP-6HP) Discharge Line Temperature Protection Error Handling

In case of DLT failure, the injection valve operates based on the mid coil and ambient sensor.

If the DLT sensor fails and a mid-coil temperature sensor is available, the injection valve will be opened based on the mid coil temperature. If the mid coil sensor fails in addition to the DLT sensor, the injection valve is controlled by the ambient temperature.

4.3.6.3 EVI System Checks (XFAL 2HP-6 HP units only)

An **E47** warning code means that the injection valve has been fully open longer than 3 minutes. An **E4B** warning code means that the temperature difference across the EVI heat exchanger is higher than expected for 3 minutes. These are only warnings, but are likely due to loss of refrigerant charge or undercharge.

4.3.6.4 Constant Liquid Temperature Mode. For Low Ambient EVI Injection (2HP-6HP)

Subcooling is generally good, but liquid refrigerant that is too cold can create sizing problems for TXVs. If the ambient is below 30°F, discharge temperature is generally well under control and so the controller disables vapor injection to operate in constant liquid temperature mode. The low ambient temperature will generate enough subcooling for the system without the need for injection. Emerson recommends a balanced port TXV (or EXV) for low ambient operation.

4.3.6.5 Low Temperature Units With EVI TXV Selection

For use with **2HP-6HP XFAL models**, Emerson recommends a balanced port TXV because it offers a wider operating range for floating liquid temperatures. In addition, the unit liquid line should be insulated since the liquid line temperature will be lower than the ambient temperature.

See **Table 4** on **page 10** for specifics regarding balanced port sizing recommendations. Applied with the low temp units it is recommended that a balanced port expansion valve be used along with a complete review of the distributor and nozzle (orifice) that is supplied with the evaporator coil being matched with the applicable condensing unit. Typically, nozzles are selected for standard TXV sizing using 100°F liquid, with the low temperature X-Line units those typical selections could be grossly oversized. See **Table 4** on **page 10** for the liquid correction safety factors when selecting those components.

4.3.6.6 Low Temperature Units with DTC Protection

XFAL-008Z/009Z/010Z/012Z units apply the ZF..KAE low temperature compressor which are provided with an injection port that is used for liquid injection protection. The purpose of the DTC valve is to provide protection when required during approved operation of the units noted above.

For the liquid injection system to be effective, a minimum of 5°F subcooled liquid at the DTC inlet is required.

A discharge line thermostat is included in the system which is applied with in the XCM25D control circuit. In the event an issue occurs with the injection circuit, the thermostat attached to the compressor discharge line will signal the controller to shut down the system.

If the discharge temperature goes above 250°F, the compressor trips off and the control displays an **E44** error. The compressor cannot turn back on until the temperature drops below 170°F and has been off for 3 minutes.

If the compressor trips more than 4 times per hour (**dLn**), the controller will lock out the compressor, requiring a manual reset or the controller power to be reset. The controller will display **L44** showing the compressor has tripped on high DLT and locked out.

Insulating the liquid line is not necessary. Also, selection of a balanced port valve is not required, but be sure to follow manufacturers guidelines for proper valve selection.

4.3.7 Medium Temperature DLT Protection

Medium Temperature units have liquid injection through the suction line to prevent compressor overheat during extreme ambient operations. The liquid injection will keep discharge temperatures below 235°F.

If the discharge temperature goes above 255°F, the compressor trips and then the controller shows an **E44** error. The compressor cannot turn back on until the discharge line temperature drops below 170°F and has been off for at least 3 minutes.

If the compressor trips more than 4 times in an hour (**dLn**) on DLT, the controller will lock out the compressor, requiring a manual reset or the controller power to be reset. The controller will display **L44** showing the compressor has tripped on high DLT and is locked out. If parameter **dLn**, which is available in the advanced options menu, is set to 0, the unit will always automatically reset.

See Section 12 for 86k Thermistor probe resistance values. Discharge line sensor is 86k, all other temperature sensors on this unit are 10k.

4.3.7.1 Medium Temperature DLT Protection Error Handling

In case of DLT sensor failure, injection is determined by the mid coil and ambient sensor.

If the DLT sensor fails and a mid-coil temperature sensor is available, the injection valve will be opened based on the mid coil temperature. If the mid coil sensor fails in addition to the DLT sensor, the injection is determined by the ambient temperature.

4.3.8 Low Temperature Small Scroll DLT Protection

The low temperature small scroll models are provided with an injection port that can be used for liquid injection.

Liquid injection is required when using the ZF*KAE scrolls for liquid injection operation, a discharge temperature control (DTC) valve must be applied.

The purpose of the DTC valve is to maintain safe internal operating temperatures.

If during normal operation the DLT temperature reaches 250°F +/- 5 degrees, the DTC valve will begin injection.

If the discharge temperature goes above 255°F, the compressor trips off and the control displays an **E44** error. The compressor cannot turn back on until the temperature drops below 170°F and has been off for 3 minutes.

If the compressor trips more than 4 times per hour (**dLn**), the controller will lock out the compressor, requiring a manual reset or the controller power to be reset. The controller will display **L44** showing the compressor has tripped on high DLT and locked out. If parameter **dLn**, which is available in the advanced options menu, is set to 0, the unit will always automatically reset.

4.3.9 Over-Current Protection

Current is measured using the two current transducers installed on the controller. If the current exceeds the compressor MCC, the controller will stop the compressor for 3 minutes and signal error **E23**. A separate parameter **iL2** is available to allow adjust the maximum current value down, but not up, in the advanced options menu.

To avoid any fault triggering during the compressor startup period caused by the high inrush current, current sensing is not processed by the controller until 6 seconds after compressor startup.

If the compressor trips more than 5 times in an hour (default) on high current, the controller will lock out the

compressor and display an **L23** lockout, requiring a manual reset or the controller power to be reset. If the parameter **oLn**, which is available in the advanced options menu, is set to 0, then the unit will always reset.

4.3.10 Incorrect Phase Sequence Protection (3 Phase Only)

The controller determines whether the sequence of three phase supply lines is proper or not. The voltage sensing terminals are connected to the 3-phase supply of the compressors. If an incorrect phase (L1, L2, and L3) is detected, the controller will trip compressor immediately and display an **L21** lockout code. The compressor will not restart until the power to the unit is turned off and L1 and L2 are switched. The reset button will not work with this error.

4.3.11 Loss of Phase Protection - Current (3 Phase Only)

The unit controller detects whether or not all the three phase supplies are available. If a phase is missing, the controller will shut down the compressor and display an **E20** error code and prevent the compressor from restarting for 3 minutes. If the unit is shut down more than 5 times in an hour (default), then unit will lock out and display an **L20** lockout code. If the parameter (**PEn**) is set to 0, the unit will always automatically reset.

4.3.12 Open Run Circuit (Single Phase Only)

After the compressor is started and runs for 6 seconds, if there is no run circuit current and the start current is still greater than 1 amp, the controller will display an **E24** error for open run circuit and shut down the compressor. The compressor will not restart for 3 minutes in the event of a trip.

If the unit is shut down more than 5 times in an hour (**oLn**), then the unit locks out and display a **L24** lockout code. If the parameter (**oLn**) is set to 0, the unit will always automatically reset.

4.3.13 Open Start Circuit (Single Phase Only)

Immediately after startup, if there is no start current for the first 500ms and the run current is greater than 1 amp, the controller will display an **E25** error for open start circuit and shut down the compressor. The compressor will not restart for 3 minutes in the event of a trip. If the unit is shut down more than 5 times in an hour (**oLn**), then the units locks out and display an **L25** lockout code. If the parameter (**oLn**) is set to 0, the unit will always automatically reset.

4.3.14 Over/ Under Voltage Protection

If the voltage drops below 10% of the minimum rated voltage or above 10% of the maximum rated voltage for 1 second, the controller will shut off the compressor and display an **E26** (under voltage) or **E27** (over voltage) error code until the voltage is back within acceptable range and the compressor has been off for 3 minutes (**oLn**).

If the compressor trips more than 5 times per hour (Default), the controller will lock out the compressor, requiring a manual reset or the controller power to be reset. If the parameter (**PE_n**) is set to 0, then the unit will always reset. The controller will display an **L26** (lockout, under voltage) or **L27** (lockout over voltage).

Phase Imbalance (3 Phase Only)

If the voltage in a given leg drops below 5% of the average voltage of the 3 legs for 1 second, the controller will display **E22** and shut the unit down (based on a parameter **P_{iL}**) for 5 minutes and until the phase imbalance is corrected.

4.3.15 Compressor Internal Thermal Protection

If the compressor's internal thermal protector trips, the contactor fails, or the contactor is miswired, the controller will detect the loss of current and display an **E2B** warning code. This happens if both of the current transducers do not sense current for 1 second when the controller sends a compressor run signal. To avoid any fault triggering during the compressor startup period caused by the high inrush current, current sensing is not processed by the controller until 6 seconds after compressor startup.

4.3.16 Fixed High Pressure Control

The high pressure control is a nonadjustable pressure switch that opens at 440 +/- 10 psig and resets at 348psig in the event of high discharge pressure. If the high pressure switch is open, the compressor shuts off immediately, ignoring any overrides. As long as the high pressure switch is open, the compressor will not run. The compressor will stay off for 3 minutes regardless of when the pressure switch resets. ---**E40** will be displayed while the unit is shut down.

If the compressor trips more than 5 times per hour, the controller will lock out the compressor, requiring a manual reset or the unit power to be reset. Error code **L40** means the compressor tripped on high pressure and is locked out. If the parameter **HP_n** is set to 0, the unit will always automatically reset.

4.3.17 Alarm Contact

The alarm contact (A1 and A2 on terminal block) is a dry contact that can be wired to an external warning device such as a buzzer or light. This relay has a 5 Amp limit, up to 250V. The alarm contact will close in the event of an alarm or lockout.

4.3.18 Anti-Flood Back Warning

System Liquid Flood Back Warning Logic:

High-side superheat is the discharge line temperature minus the mid-coil temperature. If high-side superheat is less than 18°F for longer than 30 minutes during the last 45 minutes, the controller will display **E50**, but continue running the system. When the high-side superheat climbs above 18°F for 30 minutes, then the warning signal stops.

4.3.19 High Condensing Temperature Warning

An **E46** warning means the condensing temperature exceeded 150°F. The fans will run at full speed, but the compressor does not shut down. The warning clears when the temperature drops below 140°F.

4.4 Local and Remote Displays and Communication

The controller can communicate with Modbus RTU RS485 supervisory controllers.

4.4.1 Remote Display

An optional remote display (943-0058-00) is available. The display can be mounted up to 30 feet from the unit. To connect and configure the remote display, follow the instructions included with the remote display

4.4.2 PC Connection

PC software is available to enable control of the unit from a computer. The software can be found in the software section of the Online Product Information (OPI) site: [Emerson/OPI](#)

A USB to RS485 adapter is also required. Emerson recommends FTDI USB-RS485-WE-1800-BT CABLE, USB TO RS485 SERIAL, 1.8M, WIRE END it is available on Amazon here: <http://a.co/d/0gJliFZ>

See [Appendix A](#) for detailed information

4.4.3 Supervisory controls

The X-Line unit can connect with most supervisory controls that use the RS485 ModBus communication Protocol. See [Appendix A](#) for E2 connection information. For connection to non-Emerson supervisory controls, contact your local Emerson Sales representative for support.

4.5 Control Module Overview

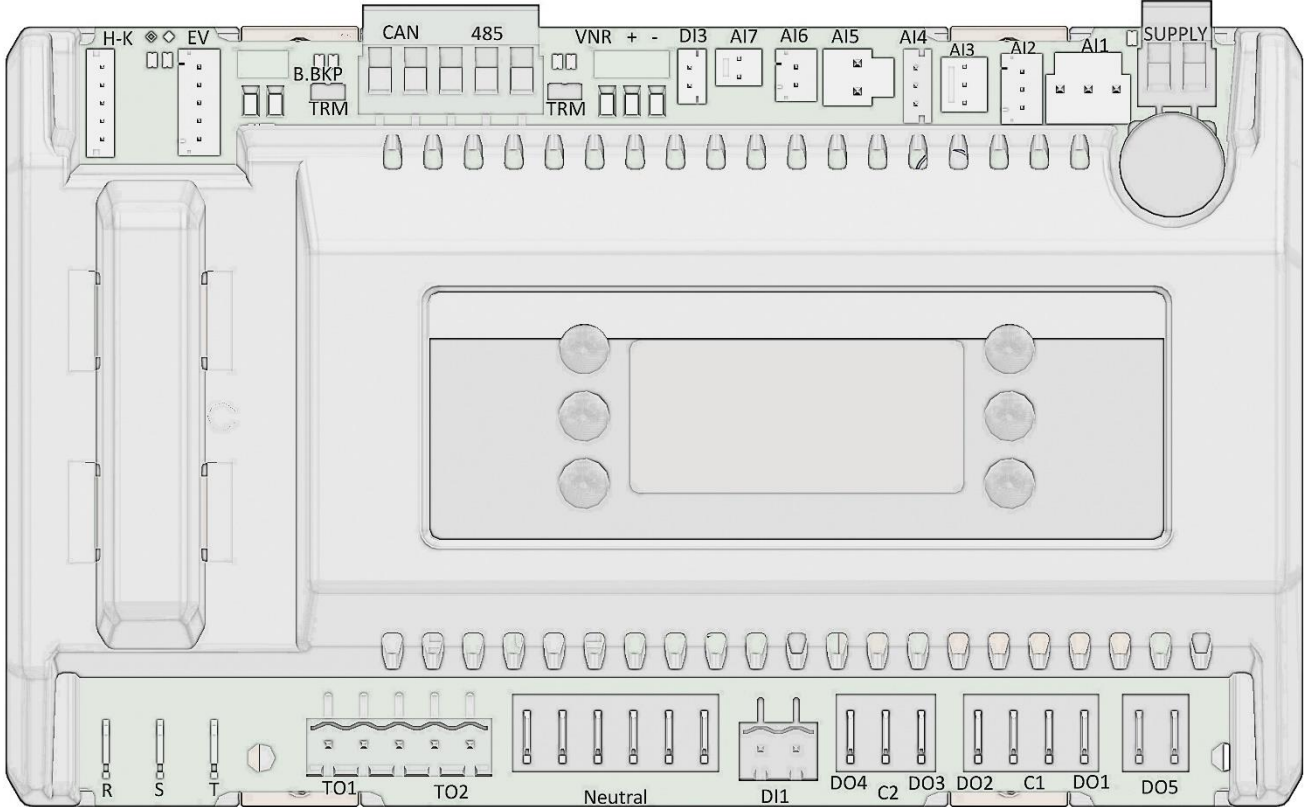

Figure 10 - Controller

NOTE: There is no field wiring to this controller except for communications. The transformer wired in the unit is for the controller only. Do not tap off the transformer to power any other devices. When removing a connector, do not pull on the wire.

Table 12 - High Voltage Connections

| Label | Connector(s) | Electrical Limit (250VAC Max) | Function |
|---------|-------------------------|--------------------------------------|--|
| C1 | ¼" Spade Connectors (2) | 25A Max Current (16A Max Each Spade) | Provides Power for Defrost Heater and Evaporator Fan Relays |
| D01 | ¼" Spade Connector | 16A Relay | Operates 40A Evaporator Fan Relay |
| D02 | ¼" Spade Connector | 16A Relay | Operates 40A Defrost Heater Relay |
| C2 | ¼" Spade Connector | 16A Max Current | Provides Power to Compressor Relay and CCH/RH Relays |
| D03 | ¼" Spade Connector | 5A Relay | Operates Compressor Contactor |
| D04 | ¼" Spade Connector | 8A Relay | Powers Crankcase Heater and Receiver Heater |
| D05 | ¼" Spade Connectors (2) | 5A Relay | Dry (Switch Only) Alarm Contact |
| DI1 | | 250VAC Max | Left Terminal – Defrost Termination Input Right Terminal – L2 |
| Neutral | ¼" Spade Connectors (6) | 25A Max Current (16A Max Each Spade) | L1 Common Terminal Strip |
| R | ¼" Spade Connector | 480V Max | L1 Voltage Sensing |
| S | ¼" Spade Connector | 480V Max | L2 Voltage Sensing |
| T | ¼" Spade Connector | 480V Max | L3 Voltage Sensing (3 Phase Only) |
| SUPPLY | | 24VAC, 40VA | Controller Power Supply |
| T01 | | 2A Wave Form Chopping Triac | Variable Speed PSC Fan Motor Control |
| T02 | | Not Used | For Future Use |

Table 13 - Sensor Connections

| Label | Function | Type |
|-------|--|-------------------------------------|
| AI1 | Suction Pressure Transducer | 0.5 to 4.5 VDC Ratio metric |
| AI2 | Condenser Temperature Sensor | 10k NTC (See Section 12 for values) |
| AI3 | Discharge Line Temperature Sensor | 86k NTC (See Section 12 for values) |
| AI4 | EVI Heat Exchanger Inlet Vapor Temperature Sensor (Low Temp Only) | 10k NTC (See Section 12 for values) |
| AI5 | EVI Heat Exchanger Outlet Vapor Temperature Sensor (Low Temp Only) | 10k NTC (See Section 12 for values) |
| AI6 | Ambient Temperature Sensor | 10k NTC (See Section 12 for values) |
| AI7 | Liquid Line Temperature Sensor (Low Temp Only) | 10k NTC (See Section 12 for values) |
| DI3 | Door Switch / ON-OFF Thermostat Dry Switch | NC Switch, 999-0220-16 Cable |
| EV | Liquid or Vapor Injection Valve | 12VDC Stepper |

Table 14 - Other Connections

| Label | Functions |
|---------------------------|--|
| VNR | Remote Display Connection |
| Connect + to + and – to - | |
| RS485 | RS-485 Communications |
| CANBUS | Future Use |
| B.BKP | Future Use |
| H-K | Hotkey programming (use with part # 043-0171-01 to reset control) |

Table 15 - Parameter List

| Label | Description | Default | Range |
|--------------------------------|--|---------|------------------|
| Default Display Value | | | |
| | Current Suction Pressure (PSIG) | | |
| Adjustable in Programming Menu | | | |
| Compressor | | | |
| Cin / E_{in} | Compressor cut in pressure set point (PSIG) | 25.0 | Cou - 135 |
| CoU / E_{ou} | Compressor cut out pressure set point (PSIG) | 15.0 | 0 - Cin |
| rEF / rEF | Refrigerant Selection for Regulation | R404A | All unit Refs |
| Low Side Control | | | |
| idF / i_{dF} | interval between defrost cycles (hour) | 8 | 0 - 120 |
| MdF / m_{dF} | Maximum length for defrost (min) | 45 | 0 - 255 |
| EdF / E_{dF} | Defrost interval mode | in | nu, in, RTC |
| Ld1 / L_{d1} | Workday defrost start 1 (hour) | 6:00 | nu, 0:00 - 23:50 |
| Ld2 / L_{d2} | Workday defrost start 2 (hour) | 13:00 | nu, 0:00 - 23:50 |
| Ld3 / L_{d3} | Workday defrost start 3 (hour) | 21:00 | nu, 0:00 - 23:50 |
| Ld4 / L_{d4} | Workday defrost start 4 (hour) | nu | nu, 0:00 - 23:50 |
| Ld5 / L_{d5} | Workday defrost start 5 (hour) | nu | nu, 0:00 - 23:50 |
| Ld6 / L_{d6} | Workday defrost start 6 (hour) | nu | nu, 0:00 - 23:50 |

Parameter List, continued

| Label | Description | Default | Range |
|---------------------------------------|---|------------------------|---|
| Real Time Clock | | | |
| Min / \overline{min} | Current minute | | 0 - 59 |
| Hr / \overline{Hr} | Current hour | | 0 - 23 |
| MdY / \overline{mdY} | day of month | | 1 - 31 |
| Mon / \overline{mon} | month | | 1 - 12 |
| YE \overline{r} / \overline{YEr} | year | | 0 - 99 |
| Password | | | |
| PAS / \overline{PAS} | Enter into PR2 level | 321 | (blank) |
| Adjustable from Advanced Options Menu | | | |
| Probe Configuration | | | |
| P1F / $\overline{P1F}$ | Probe P1 calibration (PSIG) | 0.0 | -12.0 - 12.0 |
| Display | | | |
| Lod / \overline{Lod} | Remote Display visualization | P1 | P1 - P7 |
| Compressor | | | |
| LAS / \overline{LAS} | Ambient temperature required to initiate low ambient on time (°F) | -20 | -40 - 230 |
| LMO / \overline{LMO} | Low ambient minimum on time (sec) | 6 | 0 - 255 |
| Compressor Safety | | | |
| odS / \overline{odS} | Output delay at start up (sec) | 6 | 0 - 255 |
| Con / \overline{Con} | Compressor On time with faulty probe (min) | 3 | 0 - 255 |
| CoF / \overline{CoF} | Compressor OFF time with faulty probe (min) | 3 | 0 - 255 |
| 2oF / $\overline{2oF}$ | Compressor Minimum Off Time (sec) | 120 | 1 - 900 |
| HPn / \overline{HPn} | Number of high pressure switch activation before compressor lock | 5 | 0 - 15 |
| bMP / \overline{bMP} | Bump start enable | YES | no, yes |
| dLn / \overline{dLn} | Number of activation of DLT in a hour to lock compressor | 4 | 0 - 15 |
| Condenser Fan | | | |
| MCS / \overline{MCS} | Minimum Condenser set point (°F) | 70 - XFAP 80 - XFAL | -40 - 230 |
| Low Side Control | | | |
| dFd / \overline{dFd} | Display during defrost | dEF | DEF, Setpoint, Initial Pressure, End Pressure |

Parameter List, continued

| Label | Description | Default | Range |
|------------------------------|--|-------------|--------------------------------------|
| Fdt / Fdt | Drip time (min) | 0 | 0 - 120 |
| dPo / dPo | Defrost at power-on | NO | no, yes |
| Sd1 / Sd1 | Holiday defrost start 1 (hour) | 6:00 | nu, 0:00 - 23:50 |
| Sd2 / Sd2 | Holiday defrost start 2 (hour) | 13:00 | nu, 0:00 - 23:50 |
| Sd3 / Sd3 | Holiday defrost start 3 (hour) | 21:00 | nu, 0:00 - 23:50 |
| Sd4 / Sd4 | Holiday defrost start 4 (hour) | nu | nu, 0:00 - 23:50 |
| Sd5 / Sd5 | Holiday defrost start 5 (hour) | nu | nu, 0:00 - 23:50 |
| Sd6 / Sd6 | Holiday defrost start 6 (hour) | nu | nu, 0:00 - 23:50 |
| Hd1 / Hd1 | First Weekly holiday | nu | Sun - Sat |
| Hd2 / Hd2 | second weekly holiday | nu | Sun - Sat |
| FnC / Fnc | Fans operating mode | on | cn, on, cy, oy |
| Fon / Fon | Fan ON time | 0 | 0 - 255 |
| FoF / FoF | Fan OFF time | 0 | 0 - 255 |
| dSA / dSA | Maximum door open time before alarm | 255 | 0 - 255 |
| tLS / tLS | Use the liquid line solenoid | YES | no, yes |
| Compressor Protection | | | |
| MC2 / MC2 | Adjustable current limit before trip (Amps) | MCA | 0 - MCA |
| oCn / oCn | Over Current Trips before lockout | 5 | 0 - 15; 0 = always automatic restart |
| PEn / PEn | loss of phase trips number before lockout | 5 | 0 - 15; 0 = always automatic restart |
| Utn / Utn | compressor trips before lockout | 5 | 0 - 15; 0 = always automatic restart |
| PiC / PiC | Generate warning or shut the regulation when phase imbalance | Trip | Warning, Trip |
| Digital Input | | | |
| i3F / i3F | Digital input 3 function | Door Switch | Door Switch |
| i3P / i3P | Digital input 3 polarity | CL | CL , oP |
| Serial Address | | | |
| Adr / Adr | Serial address | 1 | 1 - 247 |

4.6 Wire Diagrams

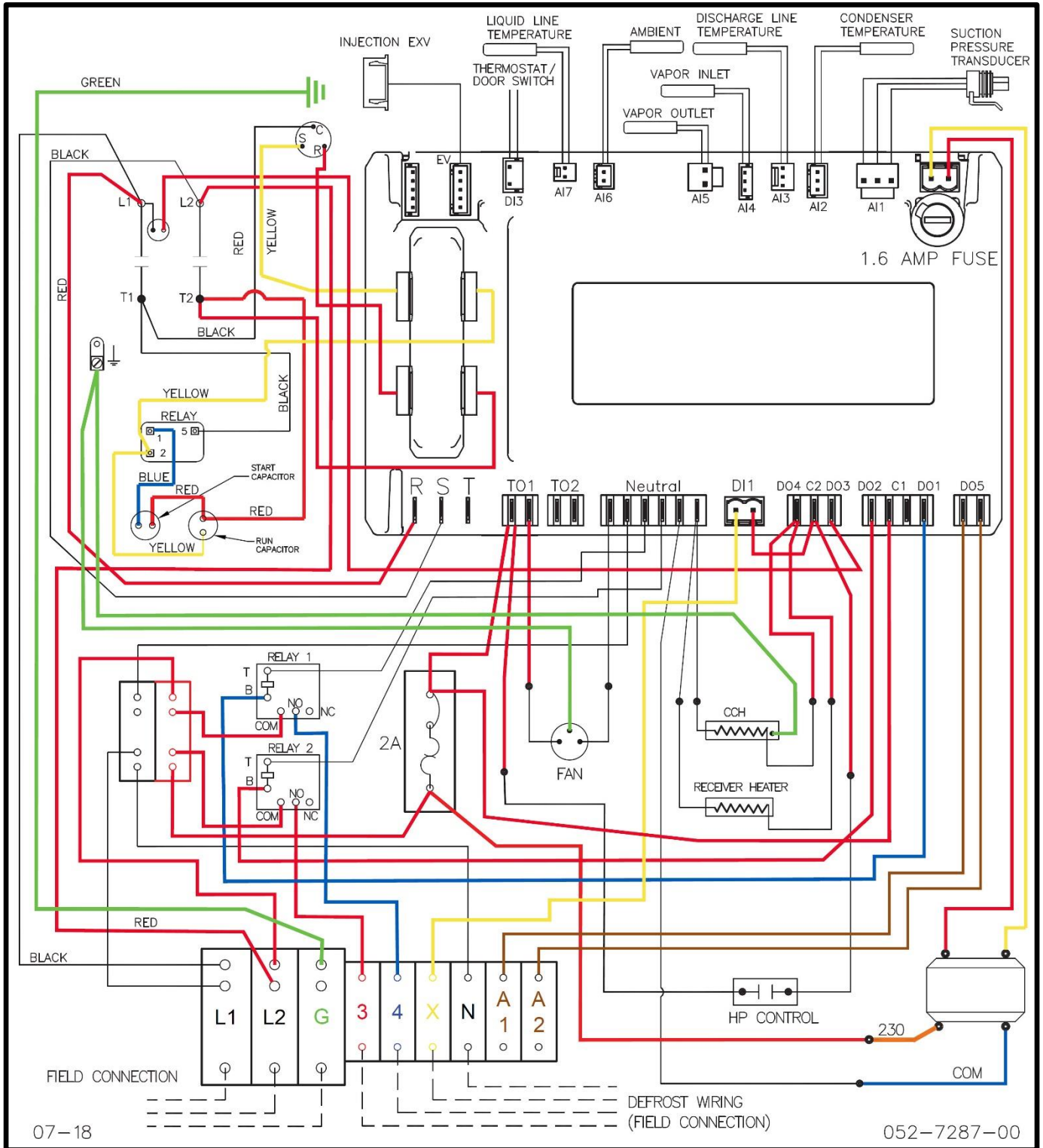

052-7287-00
Low Temp 1-Phase 2.0-3.5 HP
1 Condenser Fan

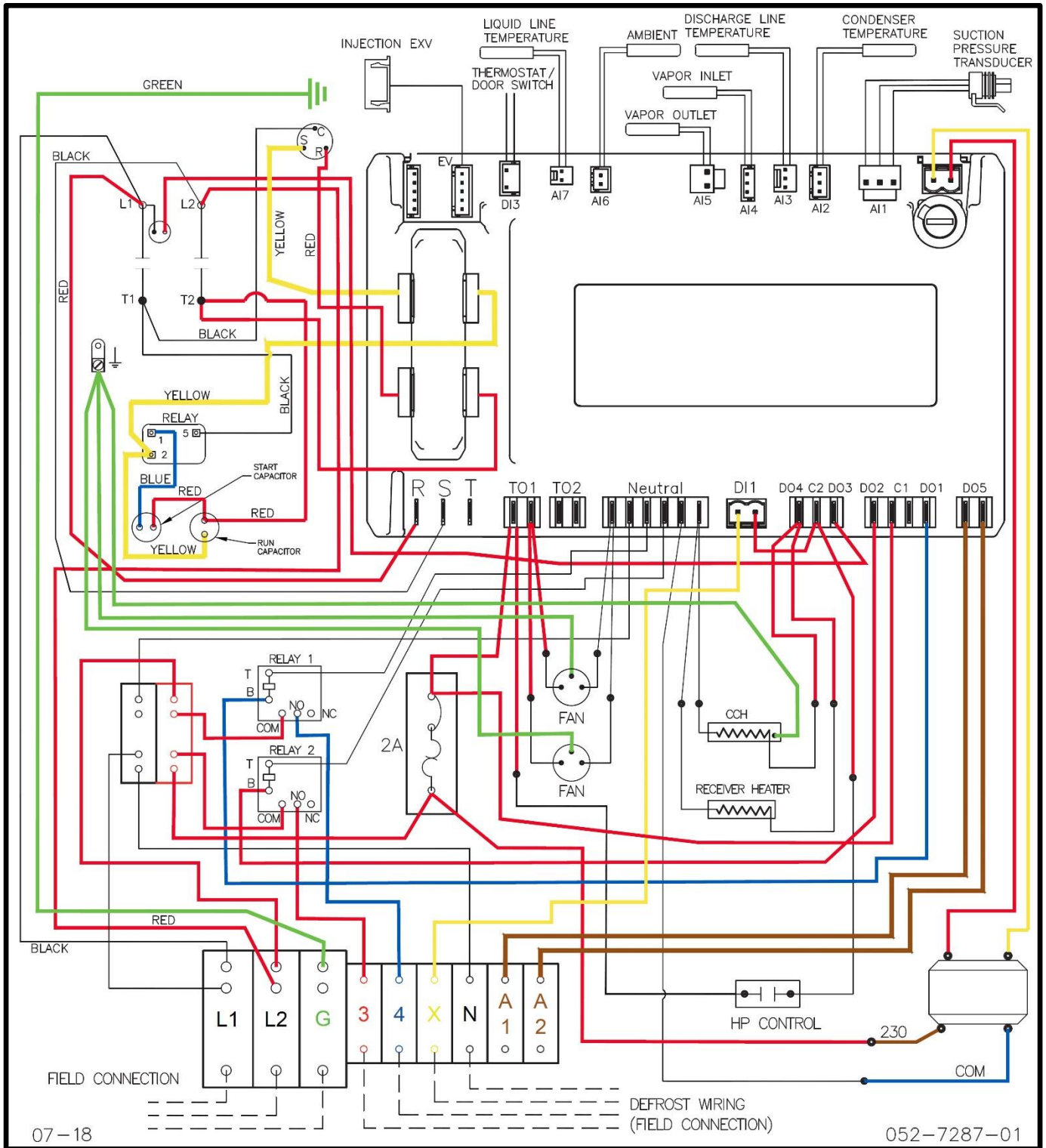

052-7287-01
Low Temp 1-Phase 4-5.1 HP
2 Condenser Fans

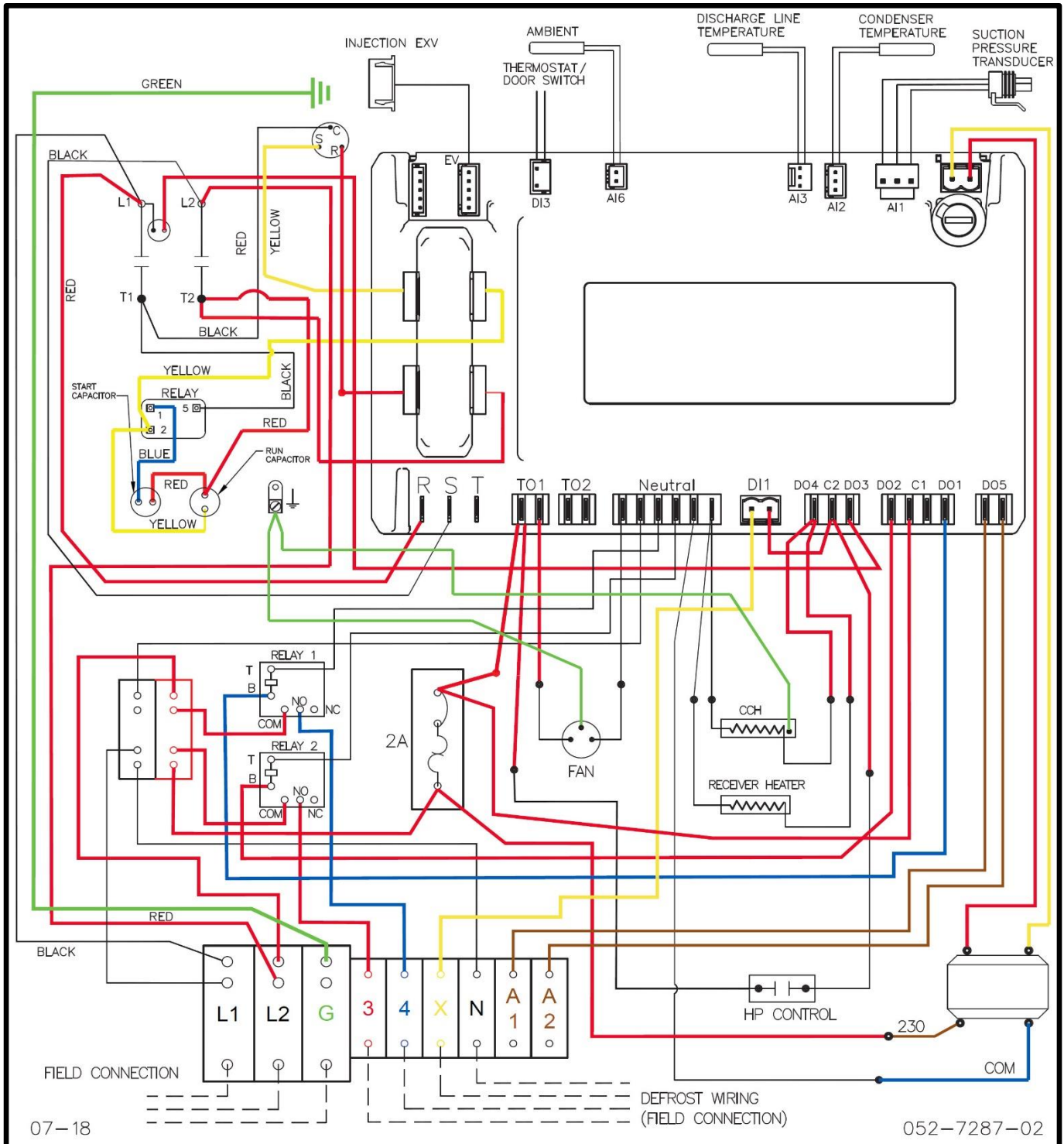

052-7287-02
Medium Temp 1-Phase 0.75-3.7 HP
1 Condenser Fan

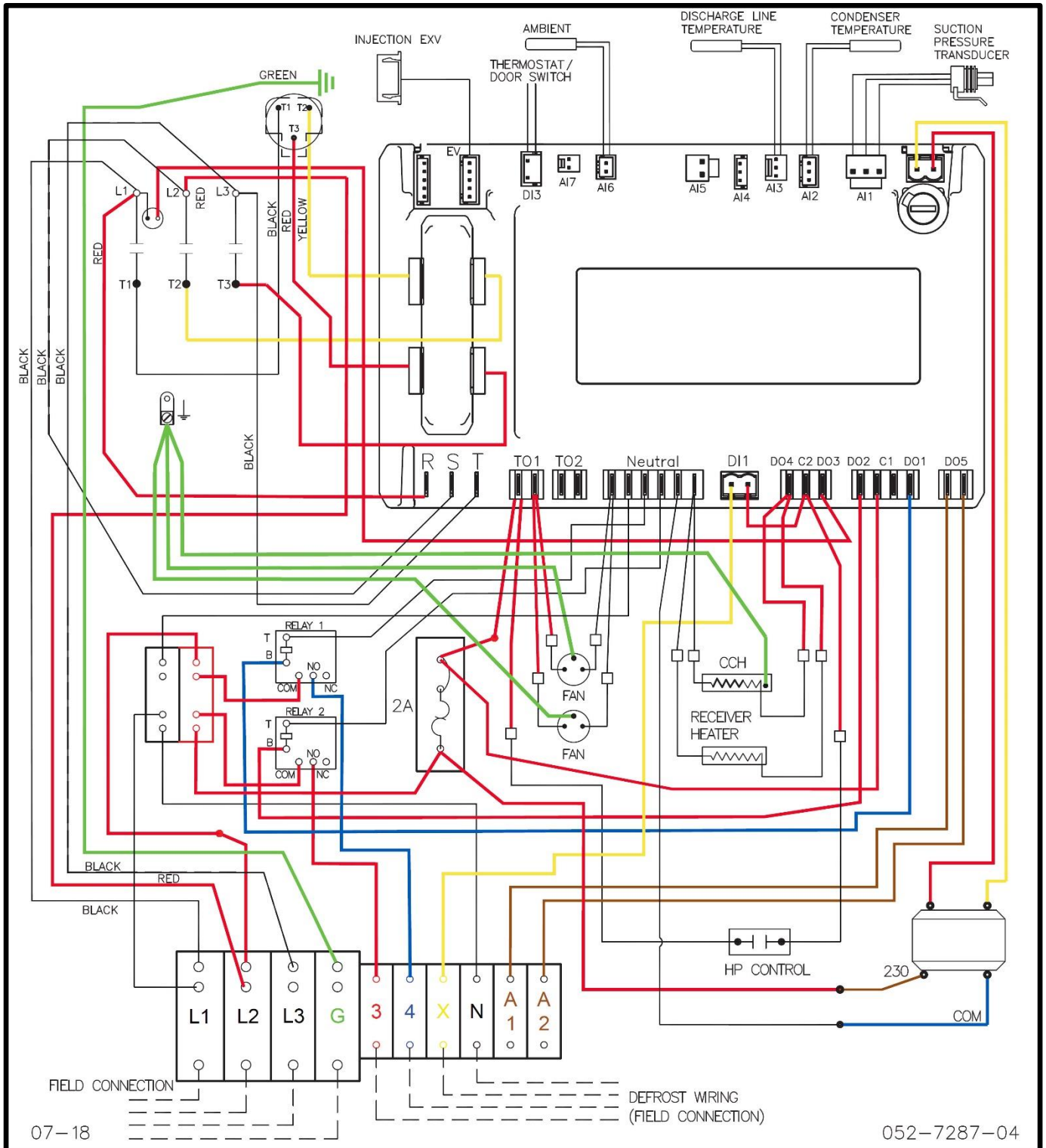

052-7287-04
Medium Temp 3-Phase 4.5-6 HP
2 Condenser Fans

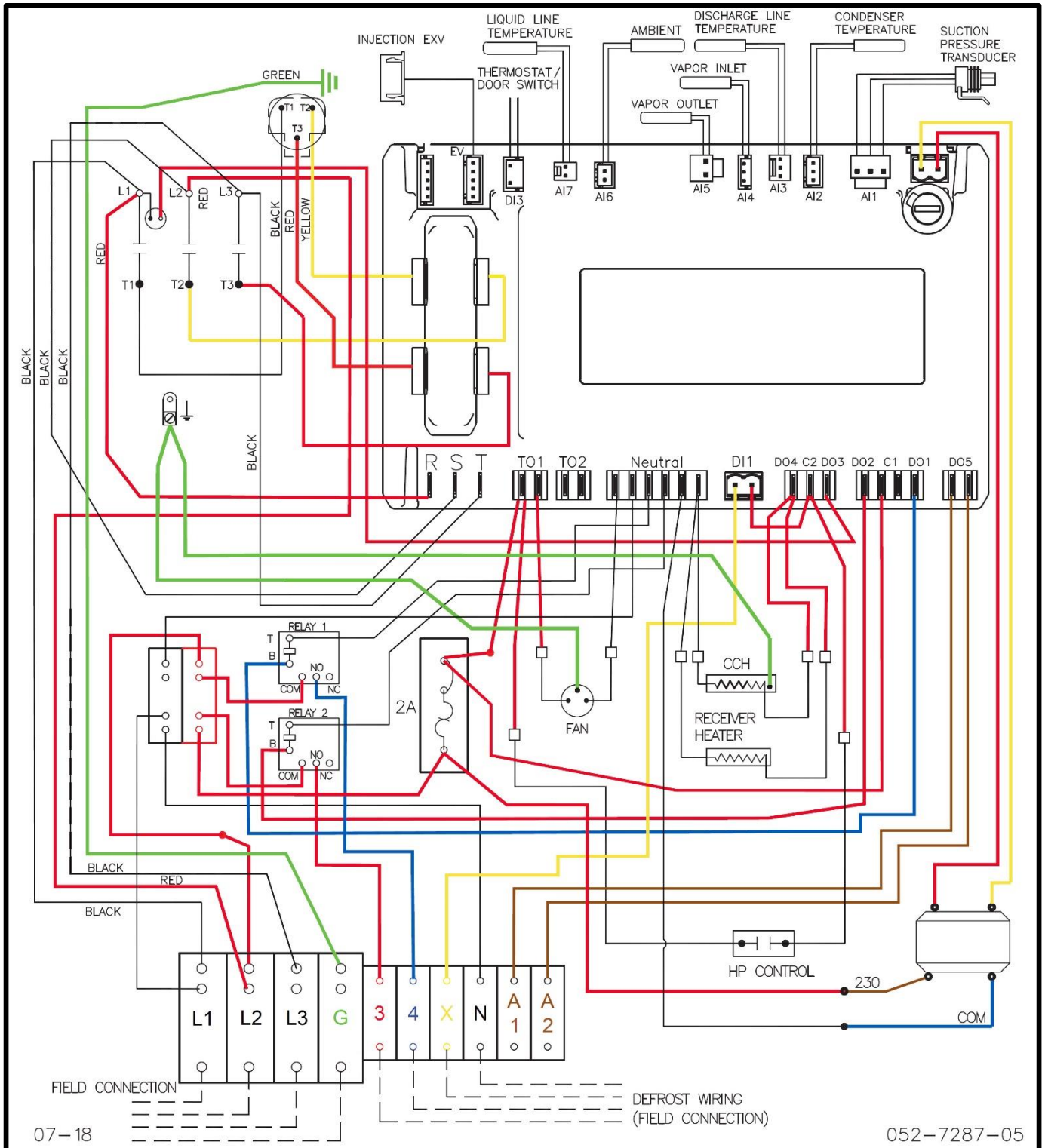

052-7287-05
Low Temp 3-Phase 2-3.5 HP
1 Condenser Fans

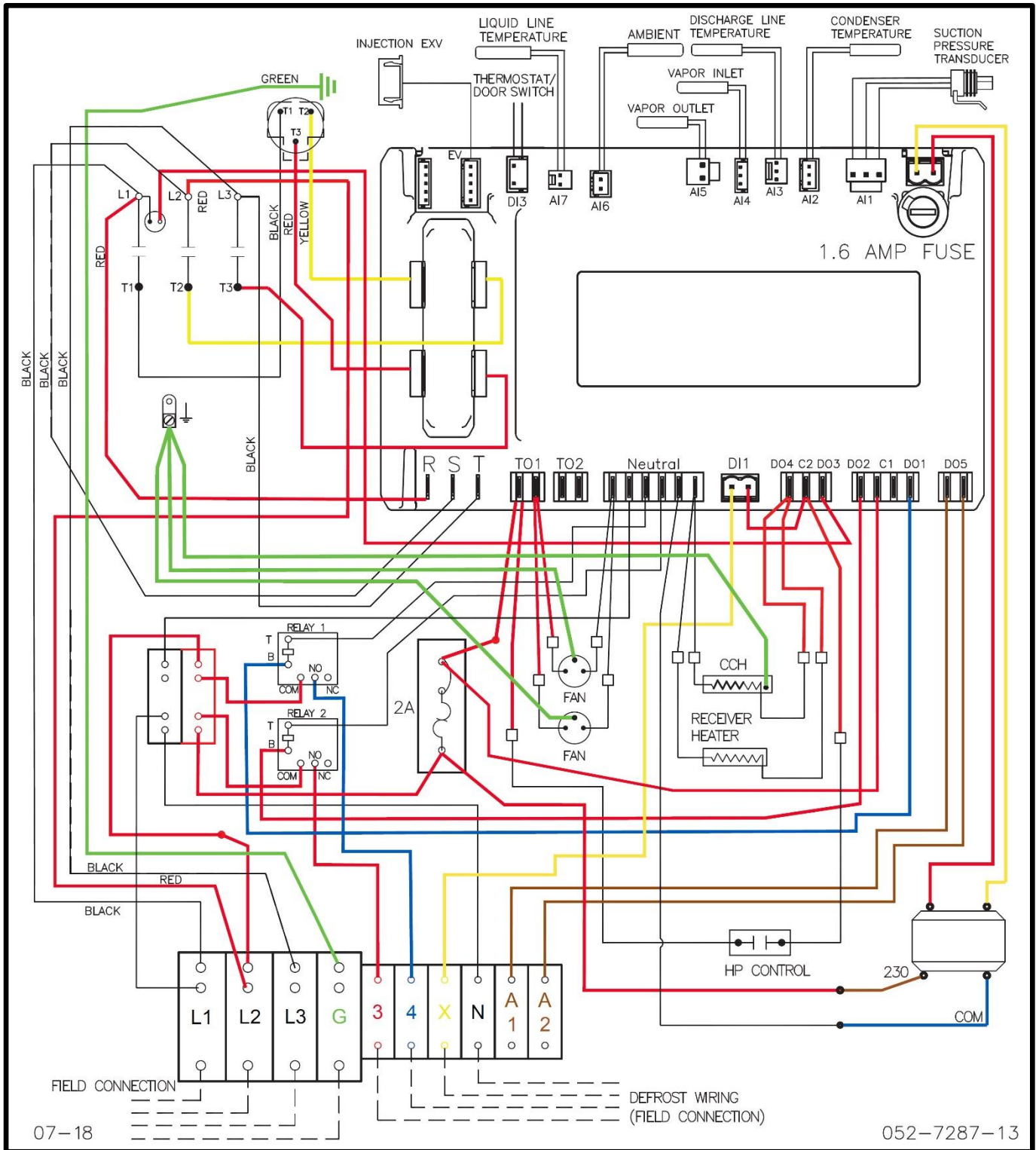

052-7287-13
Low Temp 3-Phase 4-6 HP
2 Condenser Fans

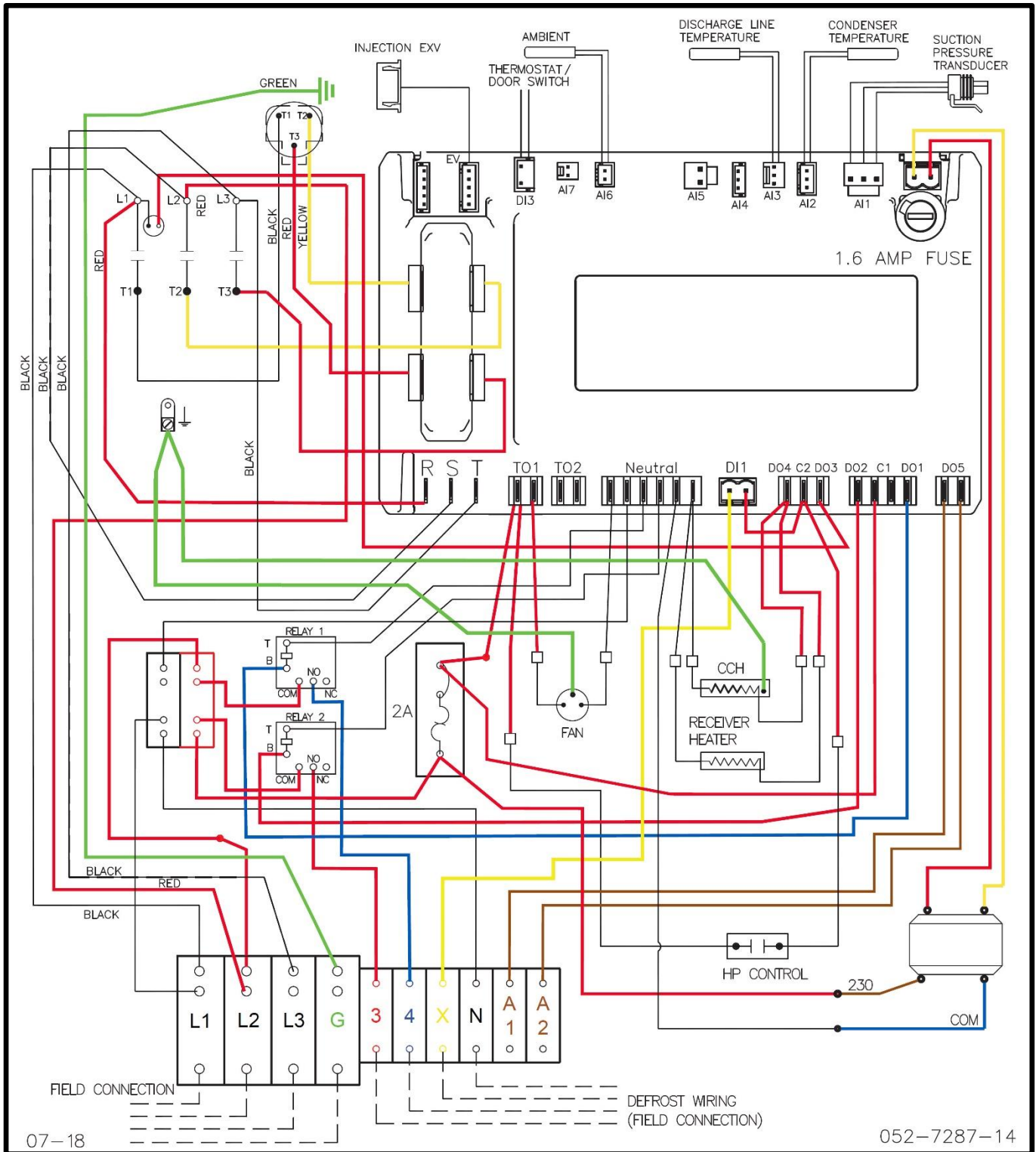

07-18

052-7287-14

052-7287-14
Medium Temp 3-Phase 0.75-3.7 HP
1 Condenser Fan

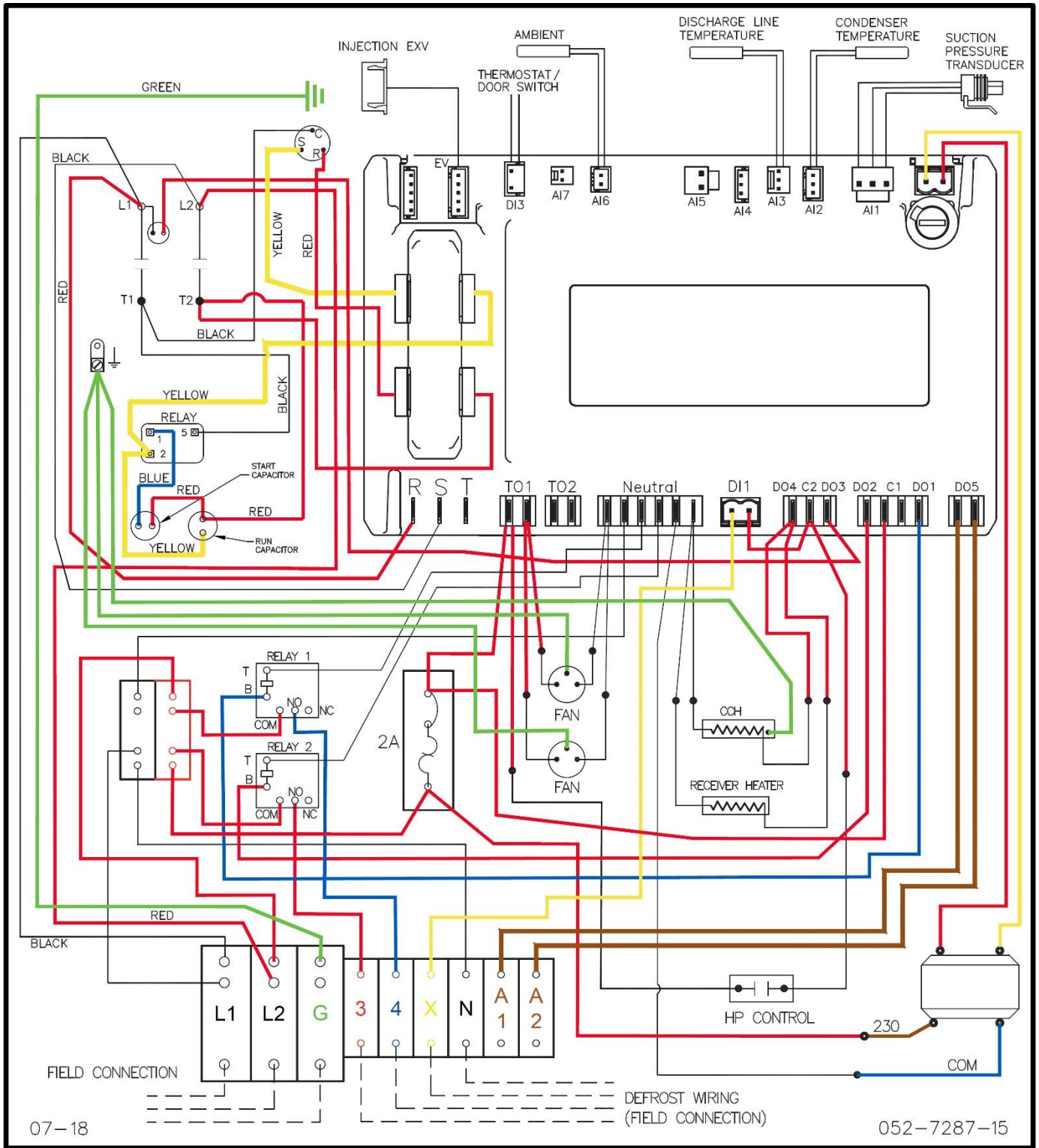

052-7287-15
Medium Temp 1-Phase 4.5-5 HP
2 Condenser Fans

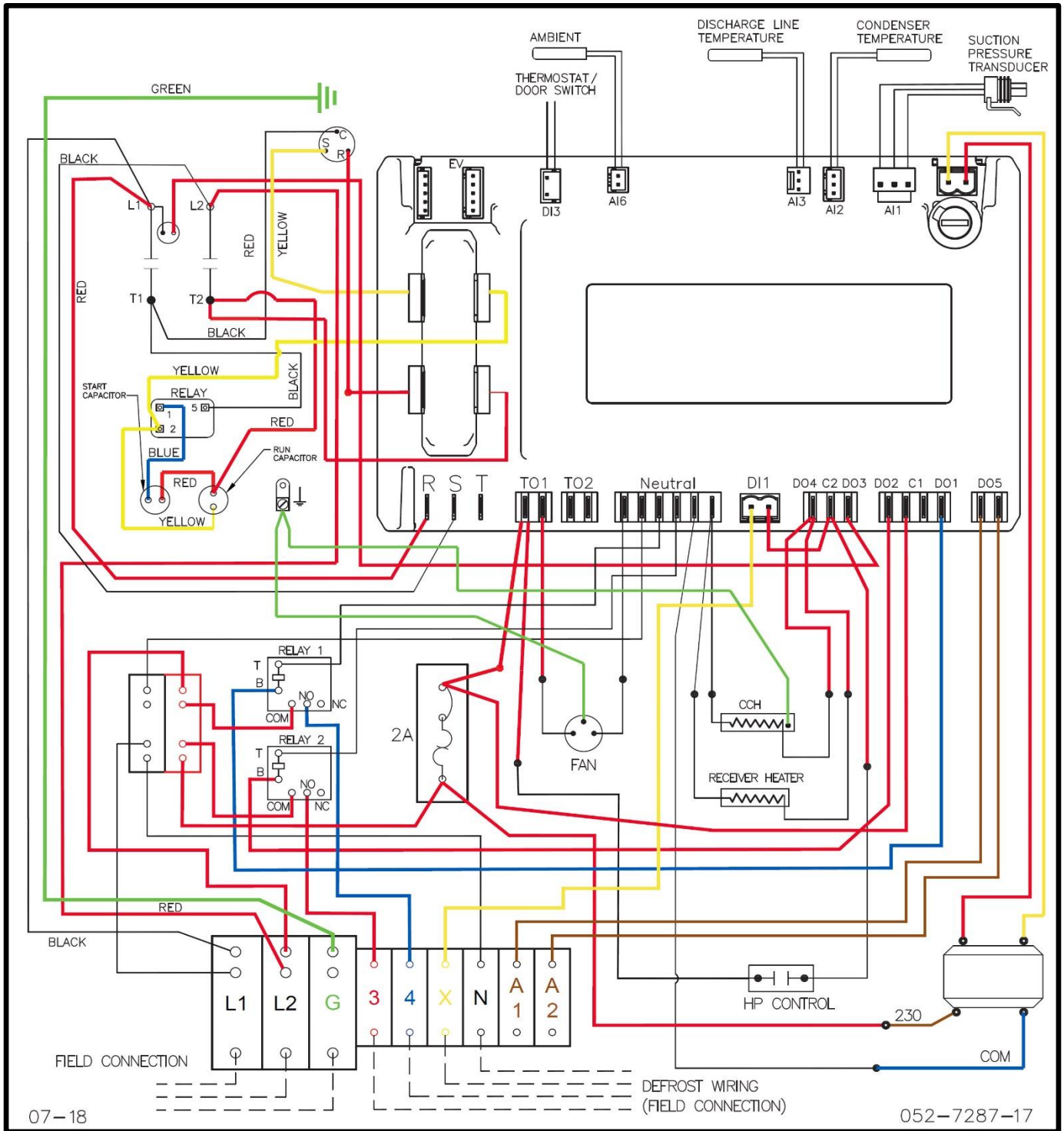

052-7287-17

Low Temp Single Phase .75 to 1.25 HP
1 Condenser Fan

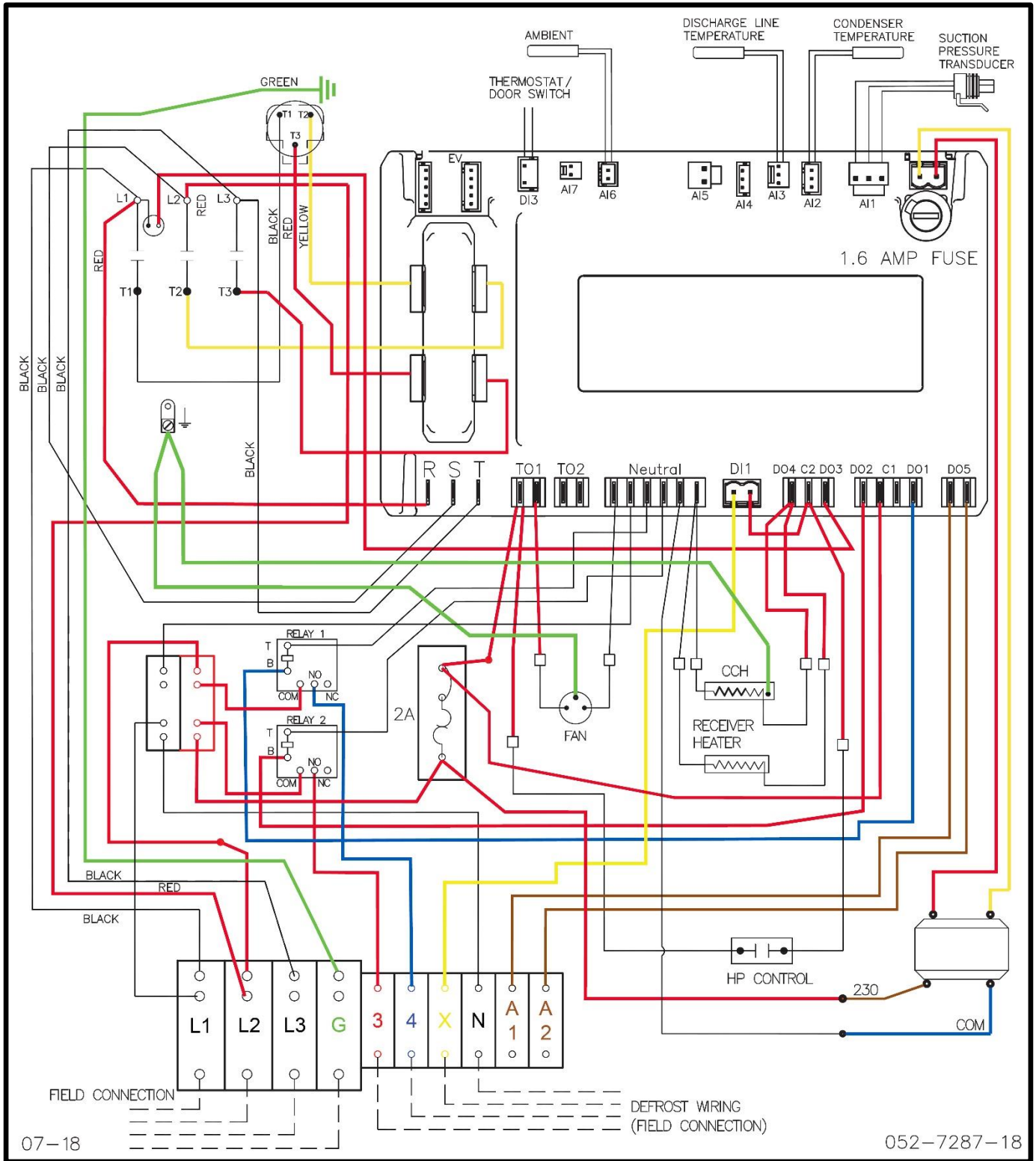

052-7287-18
 Low Temp Three Phase Single Fan .75 to 1.25 HP
1 Condenser Fan

5 Troubleshooting

5.1 Manual Stepper Control Mode for Vapor Injection (Low Temp) or Liquid Injection (Medium Temp)

For troubleshooting purposes, the stepper setting can be temporarily adjusted manually.

From the standard display screen, pressing SET and SERVICE/ALARM key for 3 seconds will enter a manual stepper control mode.

In the manual stepper control mode, the display shows the current step count of the valve.

In manual stepper control mode, all algorithms controlling the stepper valve are suspended, but the rest of the functions operate normally

The up and down arrows on the keypad open and close the valve, with the display showing the updated step count

If the controller is left untouched for 60 seconds or the set and up button are pressed together to exit, the controller will resume normal operation.

5.2 Alarm Codes

| Code | Description | Alarm Level | Diagnostic Resolution | Possible Fix |
|------------|--|---------------|---|---|
| E01 | Suction pressure transducer error | Alarm | Check wire connection to the top of the controller (A1) Check to ensure suction pressure is below 135 PSIG | Replace faulty suction pressure transducer |
| E02 | Condenser temperature sensor error | Alarm | Check wire connection to the top of the controller (A2) | Replace faulty temperature sensor |
| E03 | Discharge line temperature sensor error | Alarm | Check wire connection to the top of the controller (A3) | Replace faulty temperature sensor |
| E04 | EVI heat exchanger vapor inlet temperature error (XFALs only) | Alarm | Check wire connection to the top of the controller (A4) | Replace faulty temperature sensor |
| E05 | EVI heat exchanger vapor outlet temperature error (XFALs only) | Alarm | Check wire connection to the top of the controller (A5) | Replace faulty temperature sensor |
| E06 | Ambient temperature sensor error | Alarm | Check wire connection to the top of the controller (A6) | Replace faulty temperature sensor |
| E07 | Liquid line temperature sensor error (XFALs only) | Alarm | Check wire connection to the top of the controller (A7) | Replace faulty temperature sensor |
| E09-E10 | Current sensor error | Alarm | Check wires are properly routed through controller current transducers per wiring diagram | Replace faulty controller |
| E11-E13 | Voltage sensor error | Alarm | Check wires are connected to voltage sensing connections (R, S, T) per wiring diagram | Replace faulty controller |
| E20 L20 | Lost phase error/ lockout (Three phase only) | Alarm Lockout | Check power to unit | Check wires are connected to voltage sensing connections (R, S, T) per wiring diagram |

Alarm Codes, Continued

| Code | Description | Alarm Level | Diagnostic Resolution | Possible Fix |
|------------|---|------------------|--|---|
| E21 L21 | Phase sequence error / lockout (Three phase only) | Alarm Lockout | Reverse two phases incoming power to unit | Check wires are connected to voltage sensing connections (R, S, T) per wiring diagram |
| E22 | Phase imbalance (Three phase only) | Alarm | Check incoming electrical power | Correct incoming voltage supply |
| E23 L23 | Over current error/ lockout | Alarm Lockout | Confirm system operation to find out what is causing the compressor to pull excessive current | |
| E24 L24 | Open run circuit error/ lockout | Alarm Lockout | Check run capacitor | Check start component wiring per diagram Check wires are properly routed through controller current transducers per wiring diagram |
| E25 L25 | Open start circuit error/ lockout | Alarm Lockout | Check start capacitor | Check start component wiring per diagram Check wires are properly routed through controller current transducers per wiring diagram |
| E26 L26 | Under voltage alarm/ lockout | Alarm Lockout | Check incoming power | |
| E27 L27 | Over voltage alarm/ lockout | Alarm Lockout | Check incoming power | |
| E28 | Compressor protector trip | Warning | Check to see if compressor is tripped on protector | Check to see if contactor is functioning properly Check contractor control circuit wiring per wiring diagram |
| E40 L40 | High pressure switch trip/ lockout | Alarm Lockout | Check system cause of high pressure trip Check if circuit breaker is tripped (It provides power to the high pressure switch) | Ensure wiring to terminal C2 of the controller is correct per the wiring diagram and C2 is receiving power. Verify high pressure switch is working properly or needs replaced |
| E41 | Low Pressure Switch | Alarm | Check Suction Pressure Transducer | Replace Suction Pressure Transducer |
| E43 | Low Pressure Alarm | Alarm | Check Suction Pressure Transducer | Replace Suction Pressure Transducer |

Alarm Codes, Continued

| Code | Description | Alarm Level | Diagnostic Resolution | Possible Fix |
|------------|---|------------------|---|---|
| E44 L44 | Discharge line temperature alarm/ lockout | Alarm Lockout | Check system cause of high DLT | Faulty temperature sensor. Check sensor values versus section 12. |
| E46 | High condenser temperature alarm | Alarm | Check to see what is causing the system to run at a higher condensing temperature | Faulty temperature sensor. Check sensor values versus section 12. |
| E47 | Over injection (XFALs only) | Warning | | |
| E48 | Refrigerant shortage (XFALs only) | Warning | Check refrigerant charge | EVI injection valve may not be clogged or blocked |
| E49 | Pump Down Alarm | Alarm | Check Liquid Line Solenoid | Replace Solenoid or set tLS to off if not present |
| E50 | High side flood back alarm | Warning | Check to see if proper superheat is being maintained | |
| E66 | Door Open Alarm | Warning | Review application restrictions | Review Pg.4, Section 4.2.1.2 to eliminate the error. |
| E80 | Rtc warning, date not correct | Warning | Set the real time clock | |
| E81 | Rtf warning, communication error | Warning | Reload factory settings with the hotkey and reset the real time clock | Replace faulty controller |
| E82-E85 | Configuration Errors | Alarm | Reload factory settings with the hotkey | Replace faulty controller |
| L86 | EEPROM Memory Error | Lockout | Reload factory settings with the hotkey | Replace faulty controller |

5.3 Sensor Values

**Discharge Line
Temperature Sensor Resistance**

| °F | Resistance (kOhms) |
|-----|--------------------|
| -40 | 2889.60 |
| -31 | 2087.22 |
| -22 | 1522.20 |
| -13 | 1121.44 |
| -4 | 834.72 |
| 5 | 627.28 |
| 14 | 475.74 |
| 23 | 363.99 |
| 32 | 280.82 |
| 41 | 218.41 |
| 50 | 171.17 |
| 59 | 135.14 |
| 68 | 107.44 |
| 77 | 86.00 |
| 86 | 69.28 |
| 95 | 56.16 |
| 104 | 45.81 |
| 113 | 37.58 |
| 122 | 30.99 |
| 131 | 25.68 |
| 140 | 21.40 |
| 149 | 17.91 |
| 158 | 15.07 |
| 167 | 12.73 |
| 176 | 10.79 |
| 185 | 9.20 |
| 194 | 7.87 |
| 203 | 6.77 |
| 212 | 5.85 |
| 221 | 5.09 |
| 230 | 4.45 |
| 239 | 3.87 |
| 248 | 3.35 |
| 257 | 2.92 |
| 266 | 2.58 |
| 275 | 2.28 |
| 284 | 2.02 |
| 293 | 1.80 |
| 302 | 1.59 |
| 311 | 1.39 |
| 320 | 1.25 |
| 329 | 1.12 |
| 338 | 1.01 |
| 347 | 0.92 |
| 356 | 0.83 |

**Temperature Sensor Resistance
(Excludes DLT)**

| °F | Resistance (kOhms) |
|-----|--------------------|
| -55 | 302.2 |
| -50 | 254.9 |
| -45 | 221.7 |
| -40 | 188.5 |
| -35 | 160.2 |
| -30 | 140.4 |
| -25 | 120.2 |
| -20 | 105.7 |
| -15 | 90.8 |
| -10 | 80.3 |
| -5 | 69.4 |
| 0 | 61.5 |
| 5 | 53.4 |
| 10 | 46.5 |
| 15 | 41.5 |
| 20 | 36.3 |
| 25 | 32.4 |
| 30 | 28.5 |
| 35 | 25.6 |
| 40 | 22.5 |
| 45 | 20.3 |
| 50 | 18.0 |
| 55 | 15.9 |
| 60 | 14.4 |
| 65 | 12.8 |
| 70 | 11.6 |
| 75 | 10.4 |
| 80 | 9.46 |
| 85 | 8.47 |

| °F | Resistance (kOhms) |
|-----|--------------------|
| 90 | 7.73 |
| 95 | 6.94 |
| 100 | 6.25 |
| 105 | 5.73 |
| 110 | 5.17 |
| 115 | 4.75 |
| 120 | 4.30 |
| 125 | 3.96 |
| 130 | 3.59 |
| 135 | 3.32 |
| 140 | 3.02 |
| 145 | 2.75 |
| 150 | 2.55 |
| 155 | 2.33 |
| 160 | 2.16 |
| 165 | 1.98 |
| 170 | 1.84 |
| 175 | 1.69 |
| 180 | 1.58 |
| 185 | 1.45 |
| 190 | 1.34 |
| 195 | 1.25 |
| 200 | 1.15 |
| 205 | 1.08 |
| 210 | 0.998 |
| 215 | 0.937 |
| 220 | 0.868 |
| 225 | 0.816 |
| 230 | 0.758 |

The contents of this publication are presented for informational purposes only and are not to be construed as warranties or guarantees, express or implied, regarding the products or services described herein or their use or applicability. Emerson Climate Technologies, Inc. and/or its affiliates (collectively "Emerson"), as applicable, reserve the right to modify the design or specifications of such products at any time without notice. Emerson does not assume responsibility for the selection, use or maintenance of any product. Responsibility for proper selection, use and maintenance of any Emerson product remains solely with the purchaser or end user.

Appendix A

Local User Guide

XCM25D Network Setup on E2 Controller

By Emerson Commercial & Residential Solution





I. Overview

A. XCM25D

A controller used on X-Line condensing units which combine multiple capabilities such as:

- Condensing Unit Controls
- Condenser Fan Controls
- Defrost control
- CoreSense™ diagnostics and protection with alarming and on-board error data logging
- Demand Cooling™ compressor temperature protection
- XFAM / XFAP Models – Suction line liquid injection
- XFAL Models – (3/4 – 1¼ HP) – Direct liquid injection
- XFAL Models – (2 – 6 HP) Enhanced Vapor Injection (EVI)
- Voltage, Current and Phase monitoring

The XCM25D can be monitored by a Supervisory controller which will receive alarms and notice statuses from the X-line unit. Currently the E2 is a supervisory control available by Emerson which enable monitoring that can help with maintenance and system troubleshooting.



B. E2 Controller

The E2 controller is a microprocessor-based control system designed to provide complete control of compressor groups, condensers, refrigerated cases, and other components related to refrigeration and building control. It is the controlling component of a three-network configuration – RS485 I/O, Echelon Networks, and Ethernet, that includes input and output communication boards, remote communication software, and a variety of sensors, probes, and transducers.





C. Adding XCM25D to E2 Controller

The XCM25D can be added to the E2 but requires a License key and description file. Contact Emerson technical support for the description file (.dsc), save the .dsc file in your computer and take note of the license key, to add instances of XCM25D. Below is the information you need to provide to Emerson technical support to generate the license key:

Press Menu>7>3>1 then Press F2: Next tab and go to TCP/IP tab, For the information listed below.

| C1: General | C2: Eng Units | C3: Serial | C4: TCP/IP | C5: Peer Netwrk |
|----------------|---------------|------------|------------|-----------------|
| C6: Web Server | C7: System | C8: | C9: | C0: MORE |

General Setup: GENERAL SERV

| TCP/IP | Value |
|-----------------|---------------------|
| DHCP Enabled | : No |
| IP Address | : 10.161.223.10 |
| Subnet Mask | : 255.255.255.0 |
| DNS Server 1 | : 10.161.253.11 |
| DNS Server 2 | : 10.28.64.11 |
| DNS Server 3 | : 10.20.64.11 |
| DNS Server 4 | : |
| Default Gateway | : 10.161.223.1 |
| Domain Name | : |
| MAC Address | : 00-01-45-05-10-25 |
| BACnet Port | : 47808 |

ADVISORY SUMMARY

| | |
|---------|---|
| Fails | 3 |
| Alarms | 0 |
| Notices | 7 |

NETWORK OVERVIEW

IONet-1

E2 Unit11

Rev 4.07F02

English-US

Enter State: Y=Yes: N=NO | DHCP Enabled

F1: PREV TAB F2: NEXT TAB F3: EDIT F5: CANCEL

- E2 MAC Address
- E2 Model (Example: RX400), It is found on the top middle portion of the screen
- Number of instances of XCM25D
- Description of purpose including for what site/store

Once you secured the description file and license key, you will need to connect your computer to the E2. You have to set the Internet protocol (TCP/IP) of PC to static IP.



1. Configure PC for direct connection to E2
 - 1.1 Open your PC, Press “Start” and go to “Control Panel” then click Network and Sharing Center.

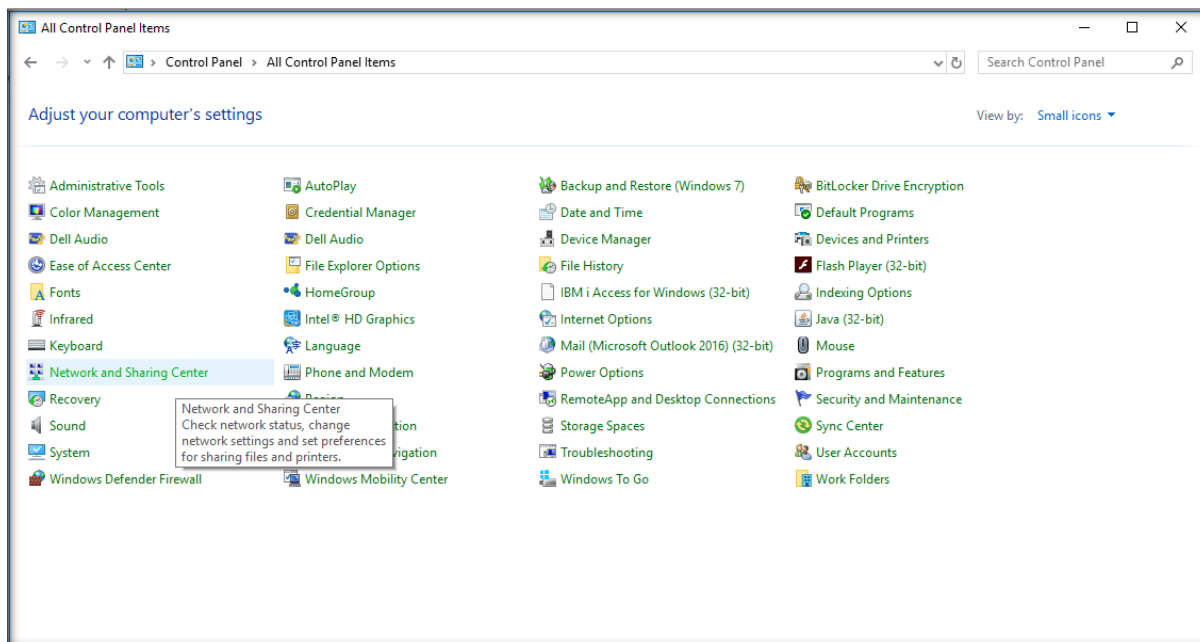

1.2 Click Change adapter settings

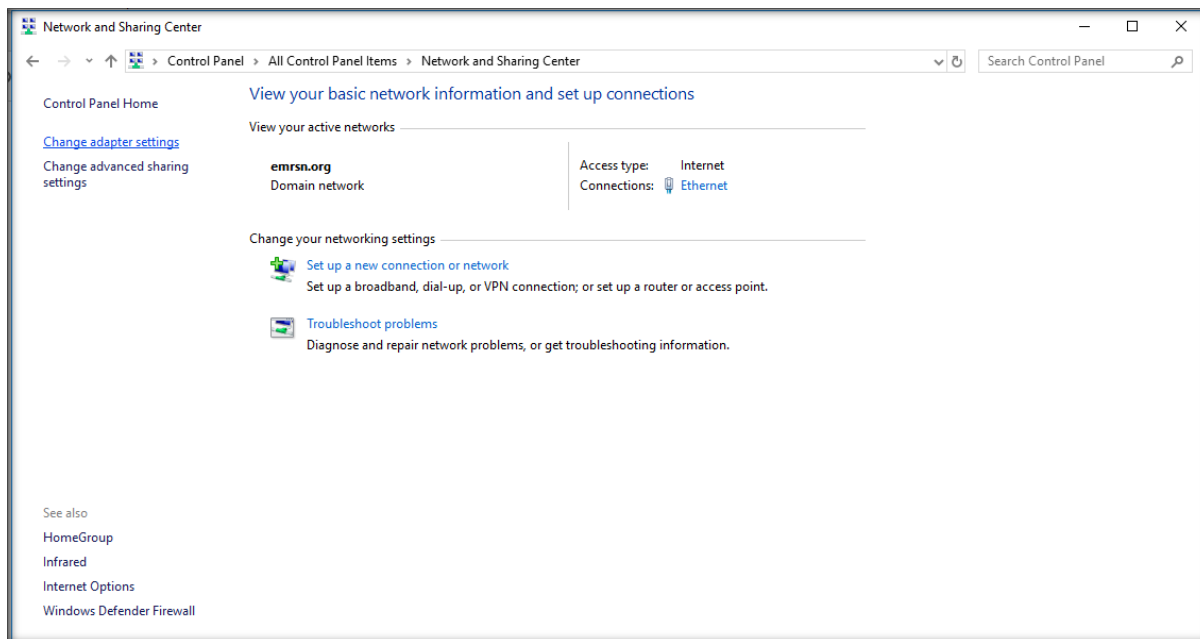



1.3 Right click on Ethernet, then click Properties

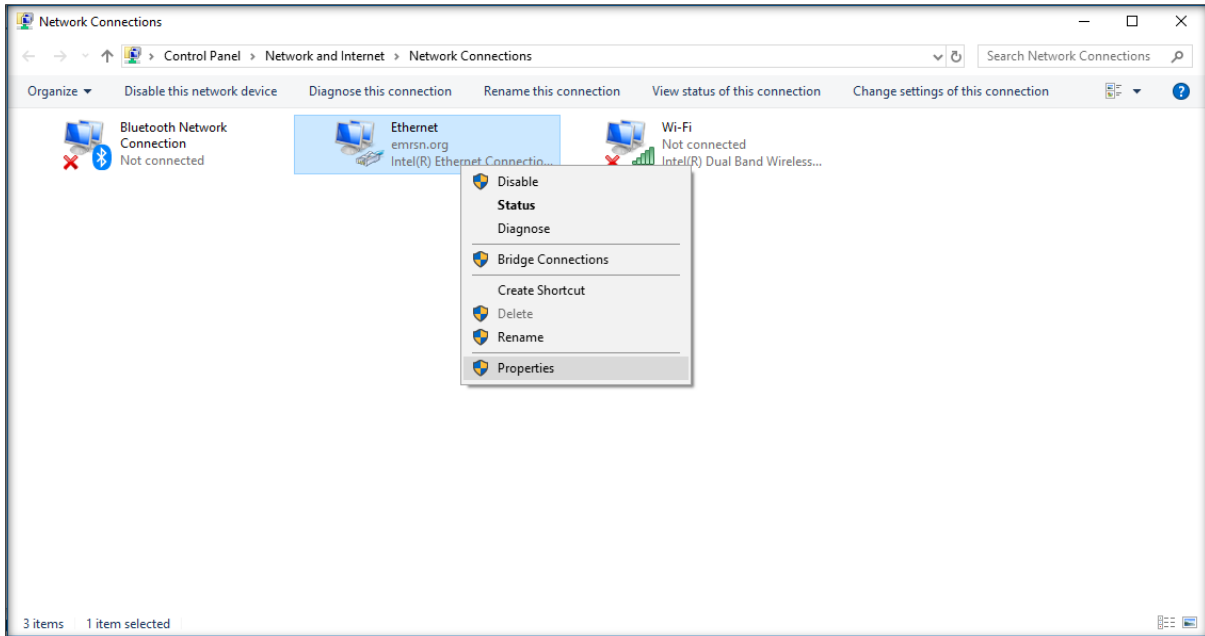

1.4 Click Internet Protocol Version 4 (TCP/IPv4) > Click Properties > Put tick mark on Use the following IP address > Put the IP address to match the E2 IP address except for the last number, change this to a value slightly different to what is actually set to E2, Also set corresponding subnet mask, same as what on E2. > Click OK

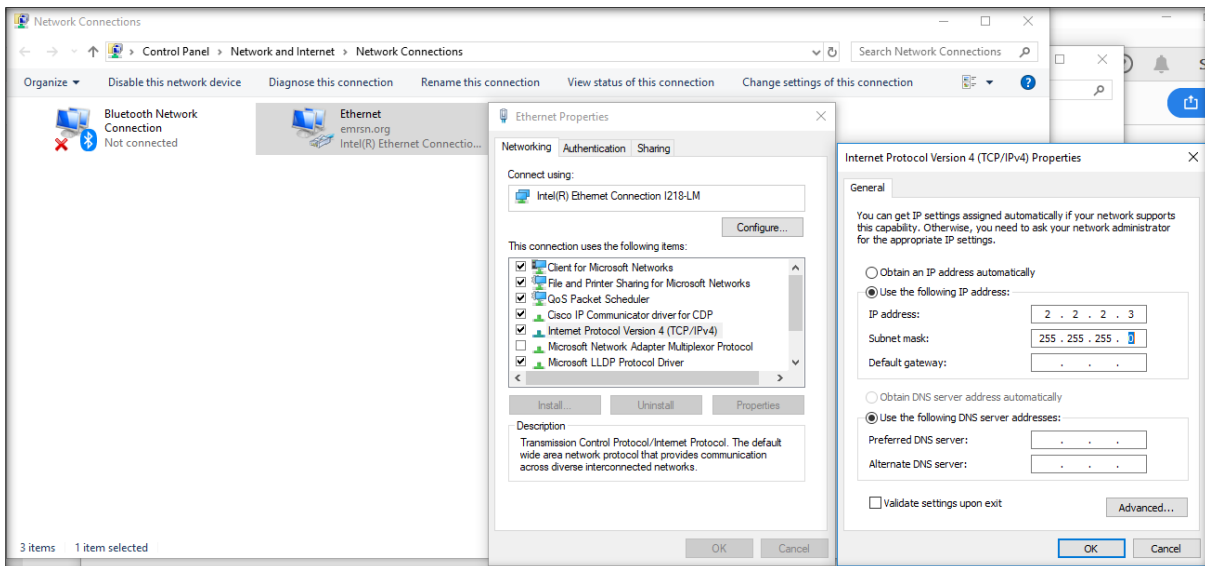

This document is not an official Technical Service Bulletin released by the Emerson Commercial and Residential Solutions. The information within represents issues and resolutions found by our Technicians while supporting our customers. The information does not pertain to all firmware, software, and/or hardware revisions of our products. When applicable, the specific versions will be contained in the document. These tips are provided as a free service by Emerson Commercial and Residential Solutions and no assumption of accuracy or liability should be implied or assumed.

For Technical Support or inquiry, email us at solutionstechsup@emerson.com or call our hotline: +1800 456 047 (Aus); T +0800 445 604 (NZ) | T 770 425 2724 (US).

XCM25D Network Setup on E2 Controller

Local User Guide



2. Upload description file via Ultrasite

Use the below description file if the XCM25D is not a native application on E2.

| Part Number | Description | File |
|-------------|-------------|--|
| 527-0573 | XCM25D |  5270573.dsc |



2.1 Launch Ultrasite (Contact Tech Support for Ultrasite Software)

2.2 Login on Ultrasite, By default the Login access which is USER/PASS

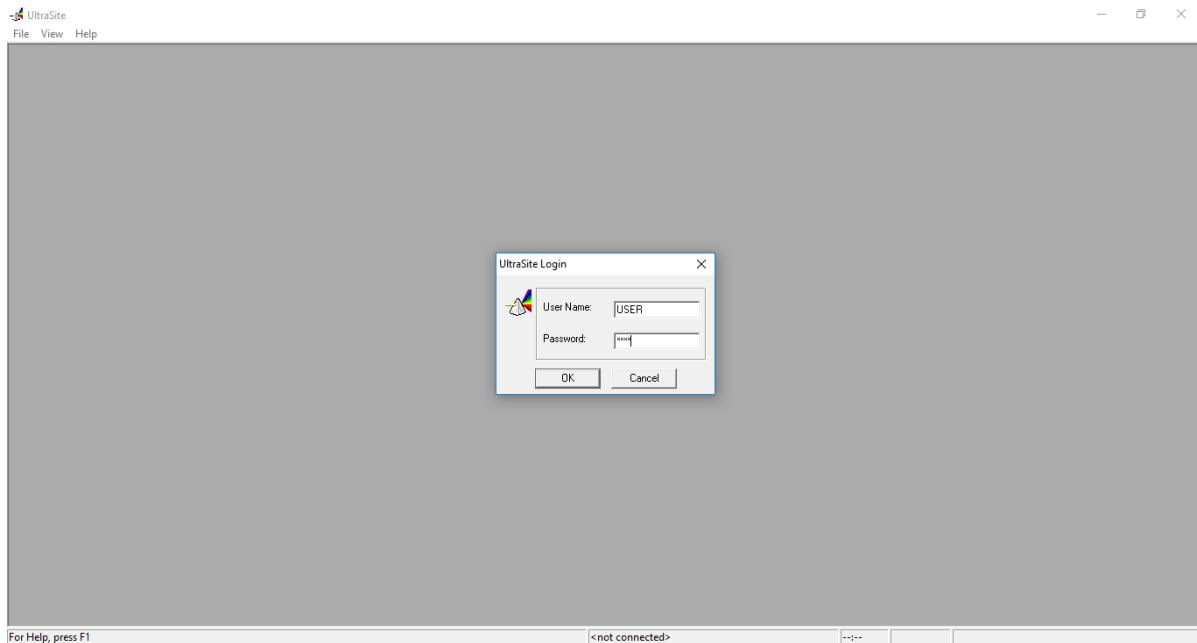



2.3 Under tree view, Right click on Ultrasite > click “Add Directory”

2.4 Specify the directory name > click OK

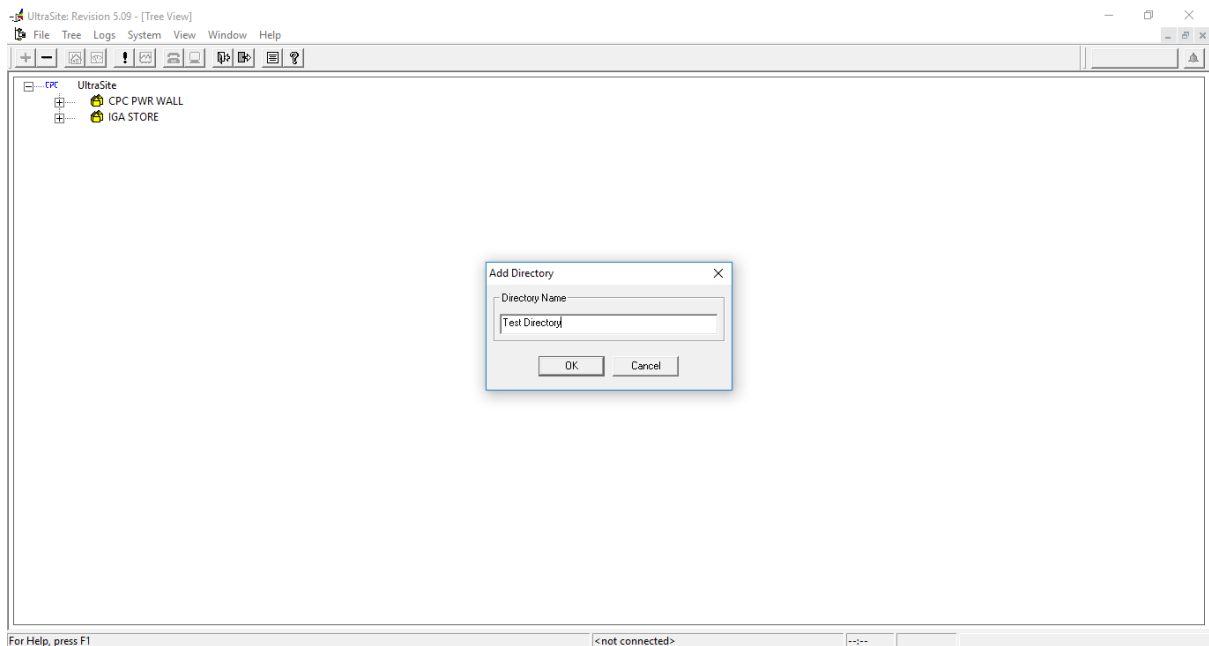

2.5 Right click on the newly created directory (Yellow house) > click “Add Site”

2.6 Specify the Site name

2.7 Under Devices, Click E2

2.8 Under Connection, Click Einstein TCP/IP

2.9 Under Network settings, specify the IP address of the E2 controller.

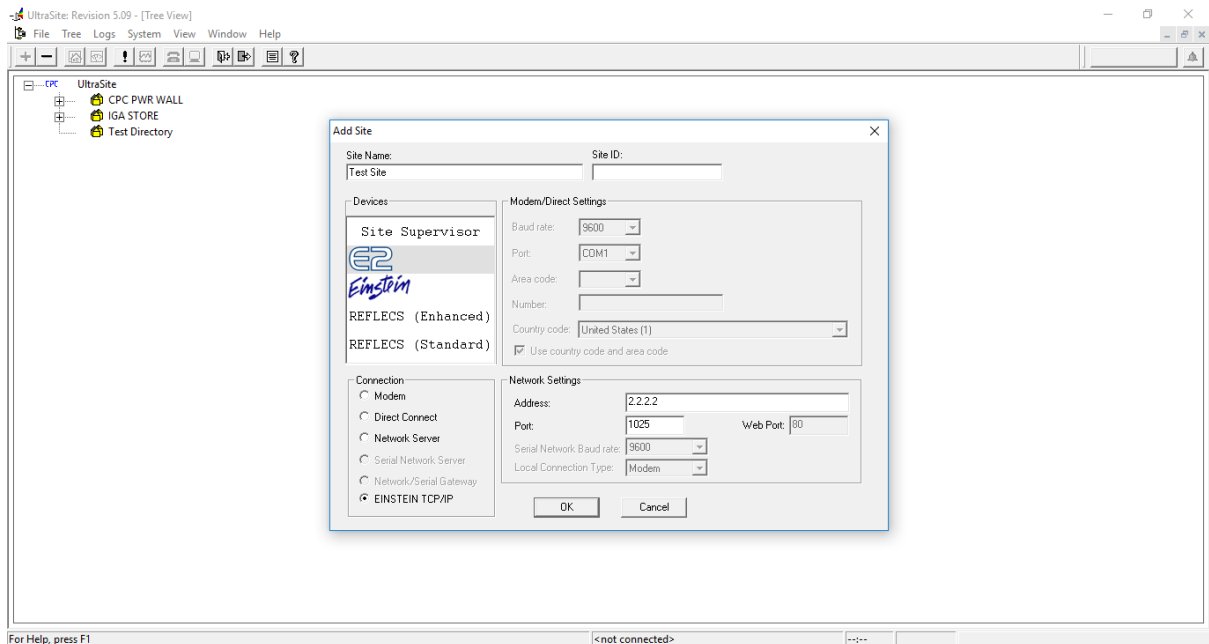

This document is not an official Technical Service Bulletin released by the Emerson Commercial and Residential Solutions. The information within represents issues and resolutions found by our Technicians while supporting our customers. The information does not pertain to all firmware, software, and/or hardware revisions of our products. When applicable, the specific versions will be contained in the document. These tips are provided as a free service by Emerson Commercial and Residential Solutions and no assumption of accuracy or liability should be implied or assumed.

For Technical Support or inquiry, email us at solutionstechsup@emerson.com or call our hotline: +1800 456 047 (Aus); T +0800 445 604 (NZ) | T 770 425 2724 (US).

XCM25D Network Setup on E2 Controller

Local User Guide



2.10 Expand the Yellow house (Specific Directory) > right click on the Site > click Connect

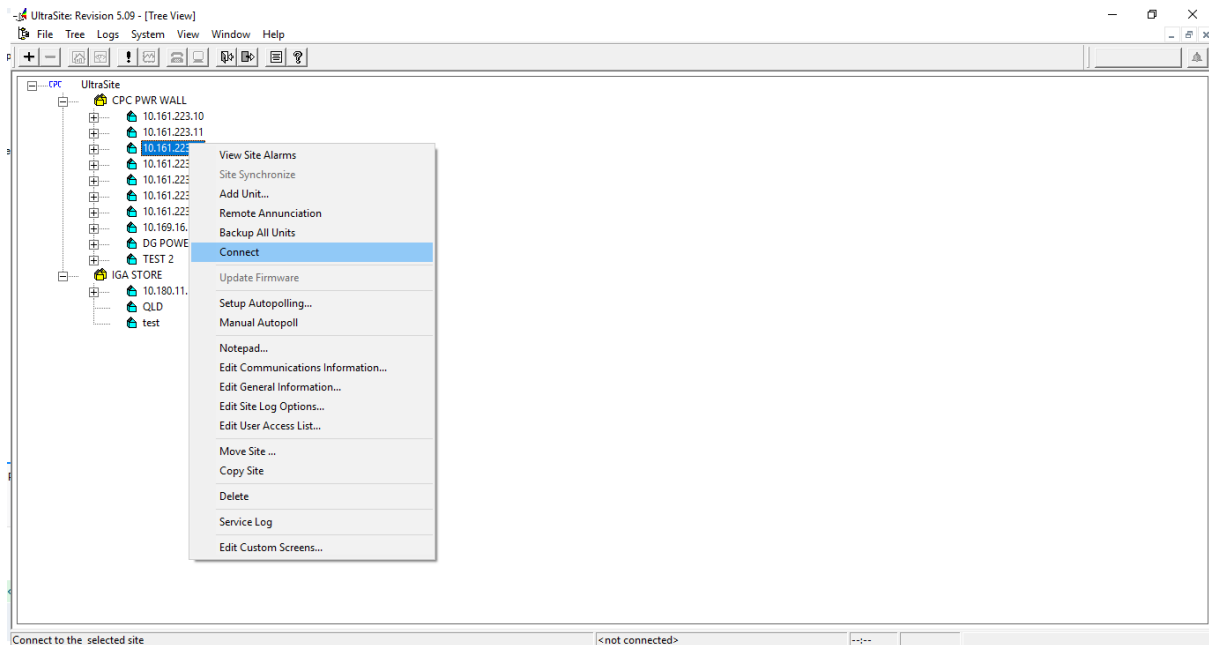

2.11 Expand the site by clicking the “+” icon on the blue house > Right click on the E2 controller on which the XCM is connected > Click Upload Description file

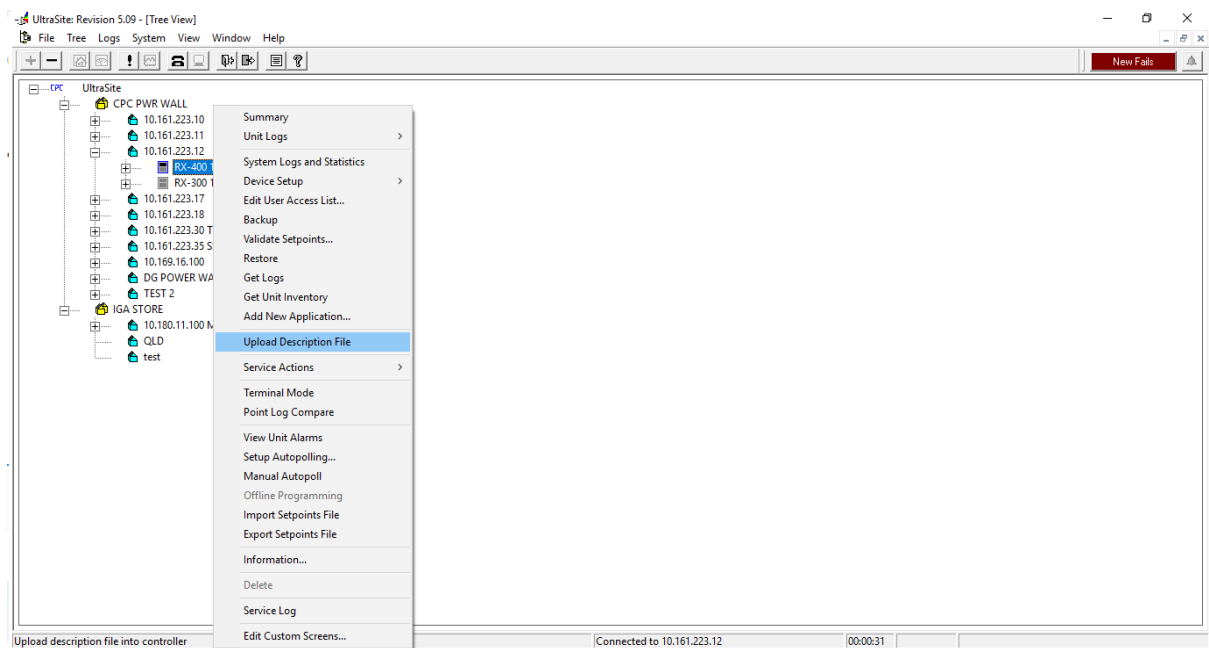

This document is not an official Technical Service Bulletin released by the Emerson Commercial and Residential Solutions. The information within represents issues and resolutions found by our Technicians while supporting our customers. The information does not pertain to all firmware, software, and/or hardware revisions of our products. When applicable, the specific versions will be contained in the document. These tips are provided as a free service by Emerson Commercial and Residential Solutions and no assumption of accuracy or liability should be implied or assumed.

For Technical Support or inquiry, email us at solutiontechsup@emerson.com or call our hotline: +1800 456 047 (Aus); T +0800 445 604 (NZ) | T 770 425 2724 (US).

XCM25D Network Setup on E2 Controller

Local User Guide



2.12 Click Browse > Locate the description file that you saved from Tech support (5270573.dsc) > Click Open> Click Upload > Click Close > Manually reboot the E2

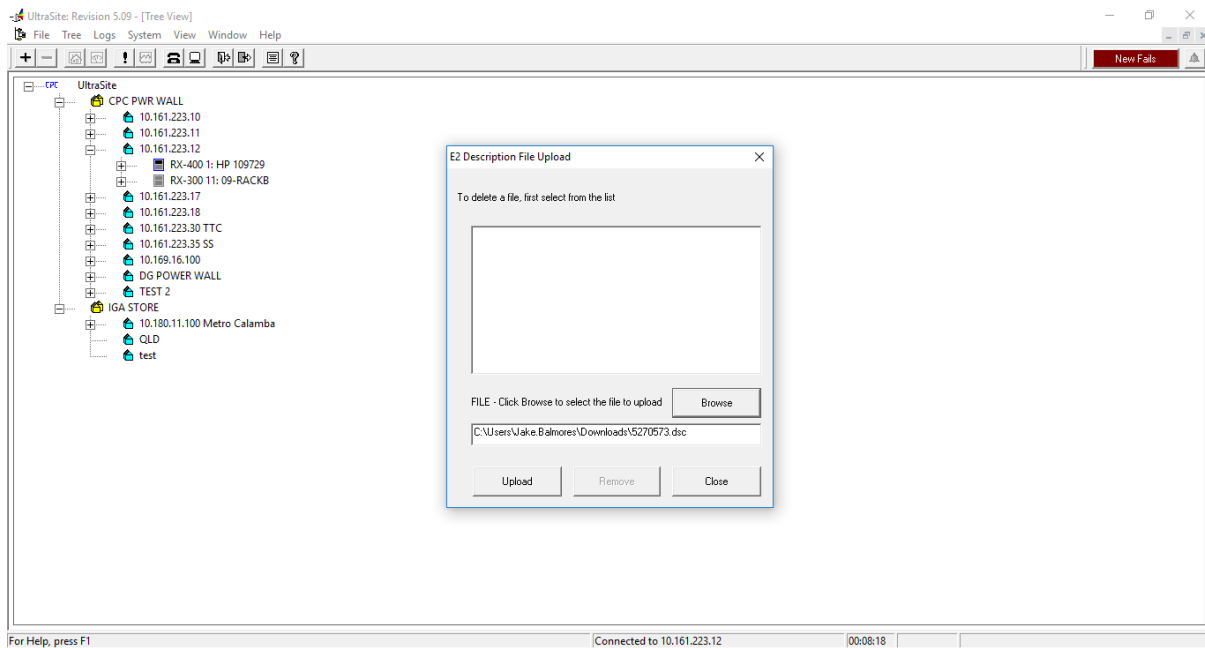

The description file is now added to the E2. Now you can add XCM25D to the E2 controller

XCM25D Network Setup on E2 Controller

Local User Guide



3. After the reboot log in on the E2 controller

```
05-04-18 9:17:57
User Login
Username: USER
Password: ****
Copyright (c) 2002-2011
Computer Process Controls, Inc.
All rights reserved.
This product and system, including protocols,
user interface and algorithms, is protected
by copyright law, intellectual property law
and international treaties.
ADVISORY SUMMARY
Fails 0
Alarms 0
Notices 2
NETWORK OVERVIEW
E2 Unit11
Rev 4.07F02
English-US
Enter desired text
F1: ABOUT F5: NEXT
```

4. From the Home Screen, Press Menu > 7 > 9 (Licensing), Press F1, Add feature, Manually type the license key received from Tech support. Wait for confirmation.

```
05-03-18 11:42:01 RX-300 Unit 11
LICENSE REPORT
XM670K_34 99 0 7BA7-87B2-2B14-5F84
CC T-Stat 10 0 C504-3866-05CB-5EB1
iProRack No Limit 0 C205-B7D3-58E2-70A6
CATLite LT20 5 0 F1C1-BBF6-7873-45C4
XM679K_42 1 0 7F52-39EE-EB35-D03F
XEU02D v1.4 10 0 D7EC-A2D7-38B6-5AA5
CES RTU 2 0 08D7-E360-8A9E-76CE
EM21v72D_CHN 2 0 FCC4-C0B0-A7CA-581F
10DINIO 1 0 5D21-2522-B25E-1F47
iPRO_CC No Limit 0 2EC2-3C60-8ACB-6CB4
X-LINE 1 0 4950-03BC-4EAC-85FE
XEU12D_04 99 0
XEU22D_11 99 0
XR35CX_56 99 0
XR75CX_56 99 0
Emerson Energy Meter 30 0
iProDAC disabled 0
Boiler Alg disabled 0
Subcooler disabled 0
MRLDS 24 0
XM670K_13 99 0
XM678D_20 99 0
ADVISORY SUMMARY
Fails 0
Alarms 0
Notices 3
NETWORK OVERVIEW
E2 Unit11
Rev 4.07F02
English-US
Lines 83 to 104 of 108
F1: ADD FEATURE
```

This document is not an official Technical Service Bulletin released by the Emerson Commercial and Residential Solutions. The information within represents issues and resolutions found by our Technicians while supporting our customers. The information does not pertain to all firmware, software, and/or hardware revisions of our products. When applicable, the specific versions will be contained in the document. These tips are provided as a free service by Emerson Commercial and Residential Solutions and no assumption of accuracy or liability should be implied or assumed.

For Technical Support or inquiry, email us at solutiontechsup@emerson.com or call our hotline: +1800 456 047 (Aus); T +0800 445 604 (NZ) | T 770 425 2724 (US).

XCM25D Network Setup on E2 Controller

Local User Guide



- From the Home Screen, Press Menu > 7 > 7 > 2 , Press F2 to access Third Party devices. Specify the quantity of the X-line units that you are commissioning and then press the staircase button to save the changes.

```

05-03-18  RX-300 Unit 11  11:44:18
Use Ctrl-X to Select CX Tabs  SETUP
C1: This Unit  C2: IO Network  C3: ECT  C4: Third Party  C5: Echelon
C6:            C7: System      C8:      C9:            C0:
Num Network Ctrls: NetSetup

Third Party Board Type      Quantity  Max
#1 : 10DINIO                0         1
#2 : CATLite LT20           0         5
#3 : CES RTU                 0         2
#4 : CT M400 UFD            0        10
#5 : EM21v72D CHN          0         2
#6 : Munters HCUC           0        10
#7 : Prodigy                 0        99
#8 : Sporlan Sub            0        10
#9 : SqD Breaker Panel      0         8
#10 : WM_CC                  0        NON
#11 : X-LINE                 1         1
#12 : XEU02D v1.4           0        10
#13 : iProLeakDet           0        10
#14 : iProRack               0        NON

ADVISORY SUMMARY
Fails      0
Alarms     0
Notices    4

NETWORK OVERVIEW

E2 Unit11
Rev 4.07F02
English-US

Enter 0 to 1 | Enter desired number of these boards
F1: PREV TAB  F2: NEXT TAB  F3: EDIT  F5: CANCEL
    
```

D. Setup the COM Port for MODBUS.

- Press Menu > 7 > 3 > 1, Press F2 to access serial tab. Set one of the available COM ports except for Com1 to MODBUS via the F4: Look Up tab, verify the baud rate=9600, data size=8, Parity=None and Stop bit=1

```

05-03-18  RX-300 Unit 11  12:08:36
Use Ctrl-X to Select CX Tabs  SETUP
C1: General  C2: Eng Units  C3: Serial  C4: TCP/IP  C5: Peer Netwkr
C6: Web Server  C7: System      C8: BACnet  C9: Sys Alarms  C0: MORE
General Setup: GENERAL SERU

Serial      Value
COM1 Connection : Not Used
COM2 Connection : IONet-1
COM2 Baud      : 9600 baud
COM3 Connection : No Modem
COM4 Connection : Not Used
COM6 Connection : MODBUS-1
COM6 Baud      : 9600 baud
COM6 Data Size : 8
COM6 Parity    : None
COM6 Stop Bits : 1
COM6 FiFo Size : Disable
COM4 Avail    : Yes
COM6 Avail    : Yes

ADVISORY SUMMARY
Fails      0
Alarms     4
Notices    12

NETWORK OVERVIEW
MODBUS-1

E2 Unit11
Rev 4.07F02
English-US

Scroll using Next/Prev keys | Connection Type for COM6
F1: PREV TAB  F2: NEXT TAB  F3: EDIT  F4: LOOK UP  F5: CANCEL
    
```

This document is not an official Technical Service Bulletin released by the Emerson Commercial and Residential Solutions. The information within represents issues and resolutions found by our Technicians while supporting our customers. The information does not pertain to all firmware, software, and/or hardware revisions of our products. When applicable, the specific versions will be contained in the document. These tips are provided as a free service by Emerson Commercial and Residential Solutions and no assumption of accuracy or liability should be implied or assumed.

For Technical Support or inquiry, email us at solutionstechsup@emerson.com or call our hotline: +1800 456 047 (Aus); T +0800 445 604 (NZ) | T 770 425 2724 (US).

XCM25D Network Setup on E2 Controller

Local User Guide



II. Network Wiring

XCM25D is connected on the E2 through MODBUS communication protocol. Make sure to configure the port settings on the E2 that is being used for the XCM25D, Refer to E2 manual for steps to configure communication ports, or the previously mentioned instructions.

The XCM is daisy chained to the E2 using shielded twisted pair wiring. Belden cable is recommended. Refer to picture below for polarity at the connector wiring.

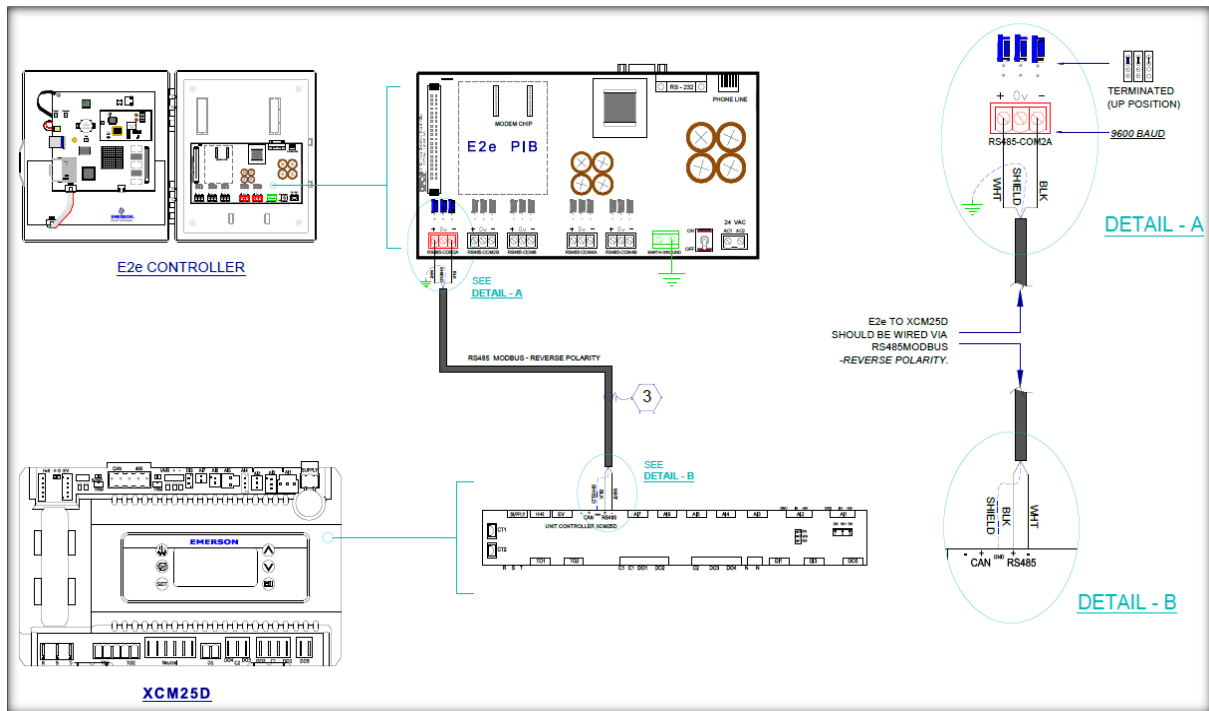

III. Communication Setup – XCM25D

1. The XCM25D controller will be able to communicate with the E2 Modbus RTU Slave RS485 slave protocol. The XCM25D Modbus parameters will be configurable via the quick access menu or the wizmate and the communication parameters will be as follows:

Adr/T01: (x) Configurable
Baud rate: 9600
Byte length: 8
Stop bits: 1
Parity: None

Baud Rate, Byte length, Stop bits and Parity must match the E2 configuration the XCM25D Modbus address Adr/T01 must be the same as what is configured/commissioned on E2. Network Summary Screen. Note that the default setting in the XCM25D is address 1, This may need to be changed during commissioning.

Example: XCM25D Adr/T01 = 6 with the corresponding X-LINE Modbus Address = 6 also. (Refer to page 7, Setup the COM Port for MODBUS.)

This document is not an official Technical Service Bulletin released by the Emerson Commercial and Residential Solutions. The information within represents issues and resolutions found by our Technicians while supporting our customers. The information does not pertain to all firmware, software, and/or hardware revisions of our products. When applicable, the specific versions will be contained in the document. These tips are provided as a free service by Emerson Commercial and Residential Solutions and no assumption of accuracy or liability should be implied or assumed.

XCM25D Network Setup on E2 Controller

Local User Guide



- Commission the XCM25D by accessing the E2 Network summary screen set up, Press Menu > 7 > 7 > 1, Scroll down the devices then highlight the recently added X-Line, Press F4 for Commission, Specify the network address then press Enter twice.

Note: Make sure the Network address is same as the **Adr/T01** parameter on the XCM.

| Name | Type | Network Address | Rev | Status |
|-----------|-------------|-----------------|---------|-----------------|
| E2 Unit11 | RX300-Refri | | 4.07F02 | This Controller |
| X-LINE001 | X-LINE | | 0.00 | No Port |

Setting Physical Address for: Unknown Device 06

Specify Physical Address Of Controller

Address: 6

MODBUS Device Address is set

ADVISORY SUMMARY

Fails 0

Alarms 0

Notices 5

NETWORK OVERVIEW

MODBUS-1

E2 Unit11

Rev 4.07F02

English-US

F5: CANCEL

- Wait for a few seconds until the X-Line shows "Online".

| Name | Type | Network Address | Rev | Status |
|-----------|-------------|-----------------|------------|-----------------|
| E2 Unit11 | RX300-Refri | Ethernet: | 11 4.07F02 | This Controller |
| X-LINE001 | X-LINE | MODBUS-1: | 6 0.00 | Online |

ADVISORY SUMMARY

Fails 0

Alarms 4

Notices 12

NETWORK OVERVIEW

MODBUS-1

E2 Unit11

Rev 4.07F02

English-US

F1: DELETE RCRD F2: STATUS F3: NET STATUS F4: COMMISSION F5: SETUP

This document is not an official Technical Service Bulletin released by the Emerson Commercial and Residential Solutions. The information within represents issues and resolutions found by our Technicians while supporting our customers. The information does not pertain to all firmware, software, and/or hardware revisions of our products. When applicable, the specific versions will be contained in the document. These tips are provided as a free service by Emerson Commercial and Residential Solutions and no assumption of accuracy or liability should be implied or assumed.

For Technical Support or inquiry, email us at solutionstechsup@emerson.com or call our hotline: +1800 456 047 (Aus); T +0800 445 604 (NZ) | T 770 425 2724 (US).



IV. Send Device Configuration to E2

1. The configured XCM25D parameters now need to be sent up to the E2.

To manually send the XCM configuration to E2. Go to the status screen of XCM, Press Enter > 9. Applications Commands > 2. Send Device cfg to E2 > Enter

You should now be able to view the correct device information on the status screen.

The screenshot shows the XCM25D status screen for 'RX-300 Unit 11 X-LINE'. The screen is divided into several sections:

- IDENTIFICATION:** X-LINE001
- DIGITAL OUTPUT:**
 - 001- Evaporator Fan: OFF
 - Compressor: OFF
 - Heater: ON
- DIGITAL INPUT:**
 - DI1-Defrost Thermostat: OPEN
 - DI2-High Pressure: OPEN
 - DI3-NOT USED
- ANALOG INPUT:**
 - P1-Suction Press: NONE PSI
 - P2-Mid Coil: NONE F
 - P3-Discharge Line: 32.00 F
 - P4-Vapor Inlet: NONE F
 - P5-Vapor Outlet: NONE F
 - P6-Ambient: NONE F
 - P7-Liquid: -3277 F
- ALARMS:**
 - Ref. Operating Error: ACTIVE
 - Elect. Error #1: INACTU
 - Elect. Error #2: INACTU
 - Low Side Alarm: INACTU
 - Misc. Alarm: INACTU
 - Reset Lockout Alarm #2: INACTU
- ADVISORY SUMMARY:**
 - Fails: 0
 - Alarms: 4
 - Notices: 12
- NETWORK OVERVIEW:** MODBUS-1 (Active)
- Bottom Right:** E2 Unit11, Rev 4.07F02, English-US

An 'Application Commands' menu is overlaid in the center, listing:

1. Send E2 Cfg to Device
2. Send Device Cfg to E2 (highlighted)

At the bottom, a green prompt reads 'Select a command to send to this application.' and a button labeled 'F5: CANCEL' is visible.

Appendix B

DTC Valve Installation Instructions

ZF03/04/05/07KAE R404A, R448A,
R449A, R407A/C/F Applications

Please see all the parts before assembly in fig. 1

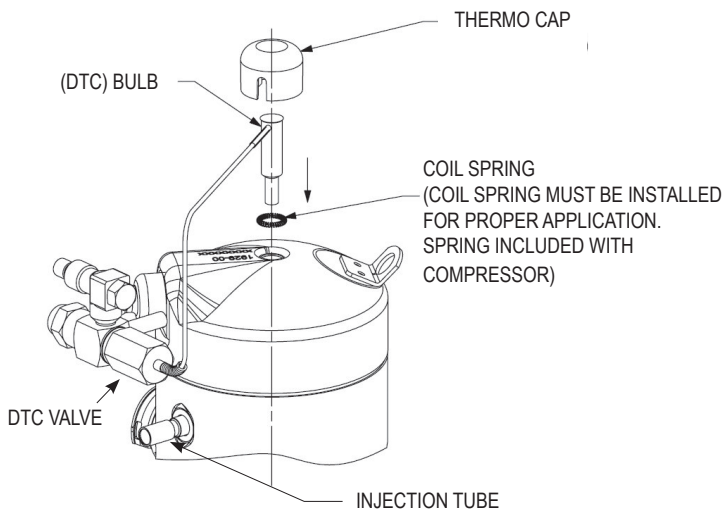

Figure 1. Explosion view

DTC valve assembly

1. Connect Discharge Temperature Control (DTC) valve to injection fitting.
 - a. DTC valve should bottom out in injection fitting. The DTC valve should be installed in a horizontal orientation. Please see the assembly in Figure 2.

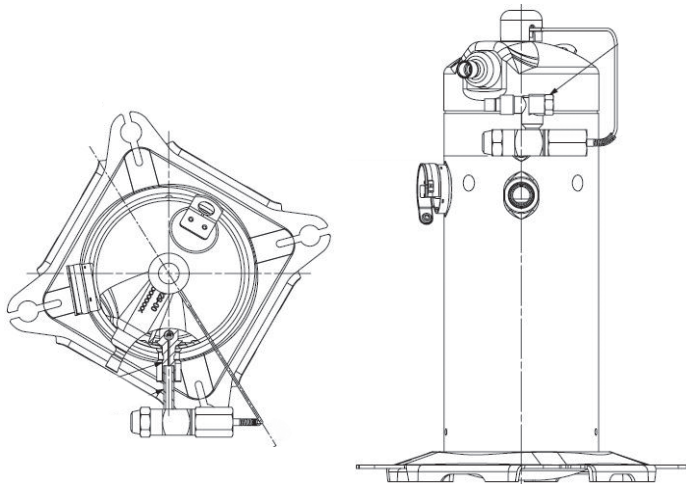

Figure 2. DTC valve installation

Compressor Brazing Procedure

IMPORTANT

Possible blockage! Compressor overheating!

Recommend maintaining flow of oxygen-free nitrogen through the system at very low pressure during brazing. Nitrogen displaces the air and prevents the formation of copper oxides in the system. If allowed to form, the copper oxide material can later be swept through the system and block screens such as those protecting capillary tubes, thermal expansion valves, and accumulator oil return holes.

Contamination or moisture! Bearing failure! Do not remove the plugs until the compressor is set into the unit. This minimize any entry of contaminants and moisture. Copeland Scroll Compressors have copper-plated steel suction, discharge, and injection tubes. These tubes are far more robust and less prone to leaks than copper tubes. Due to the different thermal properties of steel and copper, brazing procedures may have to be changed from those commonly used.

Figure 3 shows the proper procedure for brazing the DTC valve to a scroll compressor.

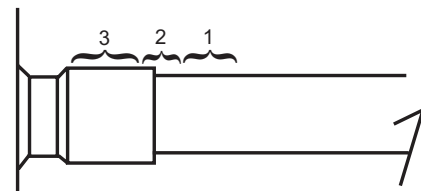

Figure 3. Tube brazing

- The copper-coated steel tubes on scroll compressors can be brazed in approximately the same manner as any copper tube.
- Recommended brazing materials: any silfos material is recommended, preferably with a minimum of 5% silver. However, 0% silver is acceptable.
- Be sure tube fitting inner diameter and tube outer diameter are clean prior to assembly.
- Using a double-tipped torch, apply heat in area 1.
- As the tube approaches brazing temperature, move the torch flame to area 2.
- Heat area 2 until braze temperature is attained, moving the torch up and down and rotating around the tube as necessary to heat the tube evenly. Add braze material to the joint while moving the torch around the joint to flow braze material around the circumference.
- After the braze material flows around the joint, move the torch to heat area 3. This will draw the braze material down into the joint. The time spent heating area 3 should be minimal.
- As with any brazed joint, overheating may be detrimental to the final result.

NOTE: Since the injection tubing design of the ZF*KA compressors includes some O-rings, a wet rag or any other suitable heat protection must be used when brazing the injection line to the compressor.

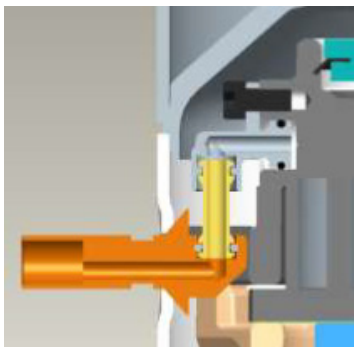

Figure 4. O-rings composing the injection inside compressor models ZF*KA

b. Verify the coil spring is seated in the thermostat tube groove area (see Figure 5) on the top of the compressor. (The spring is required for proper DTC valve installation)

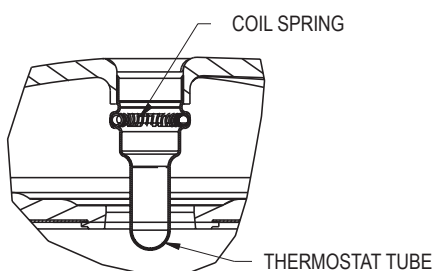

Figure 5. Coil spring location

c. Spread a thin film of thermal grease around DTC bulb. Press DTC bulb into thermostat tube on top of the compressor until the bulb bottoms out in the thermostat tube. (Install by hand, do not use excessive force) Copper tube from the DTC bulb should be approximately [1/8"] off the top of the compressor. Take care and avoid damaging or scratching the bulb. Please see Figure 6.

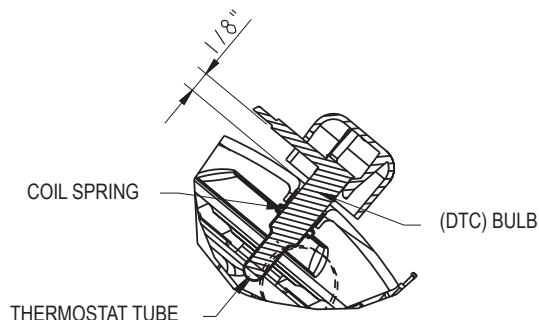

Figure 6. Bulb installation on top of the compressor

d. Snap thermal cap onto DTC bulb on top of the compressor. If there is a need to remove the thermal cap due to height limitations, thermal insulation for the bulb is strongly recommended. Please see figure 6.

2. Maximum operating temperature for valve bulb is limited to [293°F].
3. Ensure liquid refrigerant is available in the line feeding DTC valve prior to starting the compressor. Failure to do this will result in damage to the DTC valve and compressor.

DTC Valve Removal

1. Close valves to isolate the compressor from the system.
2. Evacuate the compressor and ensure no pressure remains.
3. **To disconnect:**

Heat joint areas 2 and 3 slowly and uniformly until the braze material softens and the tube can be pulled out of the fitting.

4. **To reconnect:**

See **Compressor Brazing Procedure**. Recommended brazing materials: Silfos with minimum 5% silver or silver braze used on other compressors. Due to the different thermal properties of steel and copper, brazing procedures may have to be changed from those commonly used.

Appendix C: X-Line Service Parts

Contents

- Single Phase “CFV” Panel Diagram..... 2
- Three Phase “TFC” Panel Diagram 3
- XFAL (3/4 – 1 ¼ HP) Unit Diagram..... 4
 - Parts List (XFAL-008Z, 009Z)..... 5
 - Parts List (XFAL-010Z, 012Z)..... 6
- XFAL (2 - 6 HP) Unit Diagram 7
 - Parts List (XFAL-020Z, 030Z)..... 8
 - Parts List (XFAL-040Z, 050Z, 051Z, 060Z)..... 9
- XFAM / XFAP Unit Diagram 10
 - Parts List (XFAM-008Z, 010Z) 11
 - Parts List (XFAM-012Z, 015Z) 12
 - Parts List (XFAM-017Z, 020Z) 13
 - Parts List (XFAM-022Z, 025Z) 14
 - Parts List (XFAM-030Z, 033Z) 15
 - Parts List (XFAM-037Z, 045Z) 16
 - Parts List (XFAM-050Z, 060Z) 17
 - Parts List (XFAP-015Z, 017Z) 18
 - Parts List (XFAP-022Z, 030Z) 19
 - Parts List (XFAP-045Z, 050Z) 20
 - Parts List (XFAP-060Z) 21

Single Phase "CFV" Panel Diagram

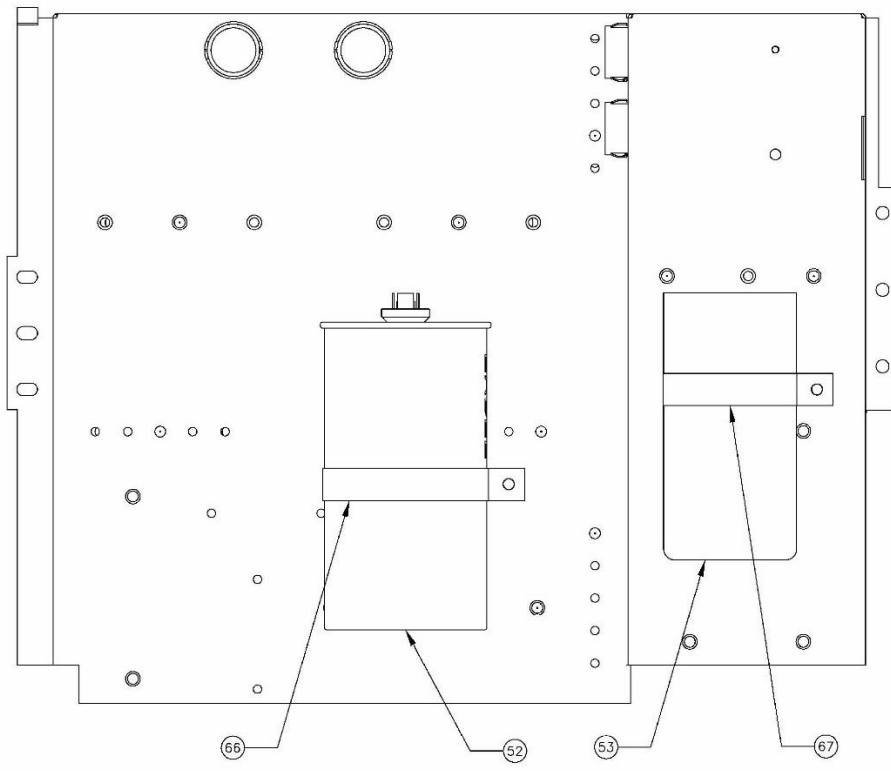
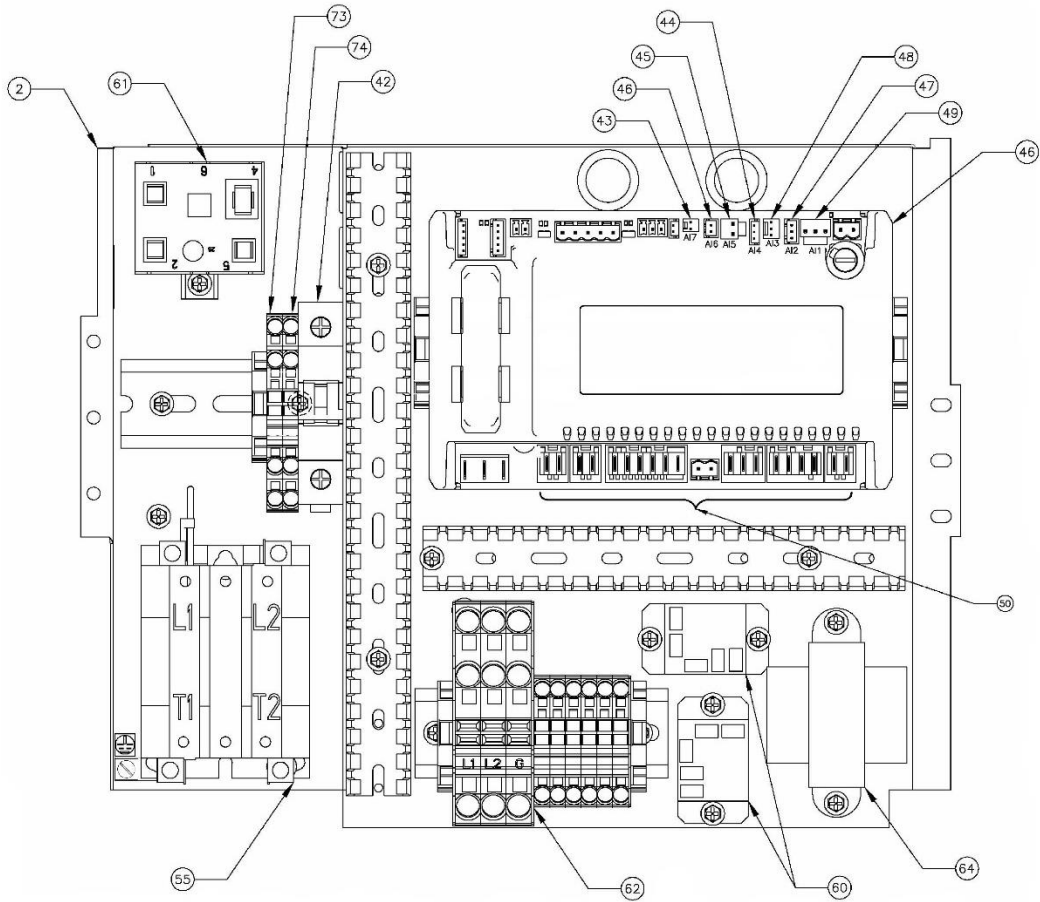

Three Phase "TFC" Panel Diagram

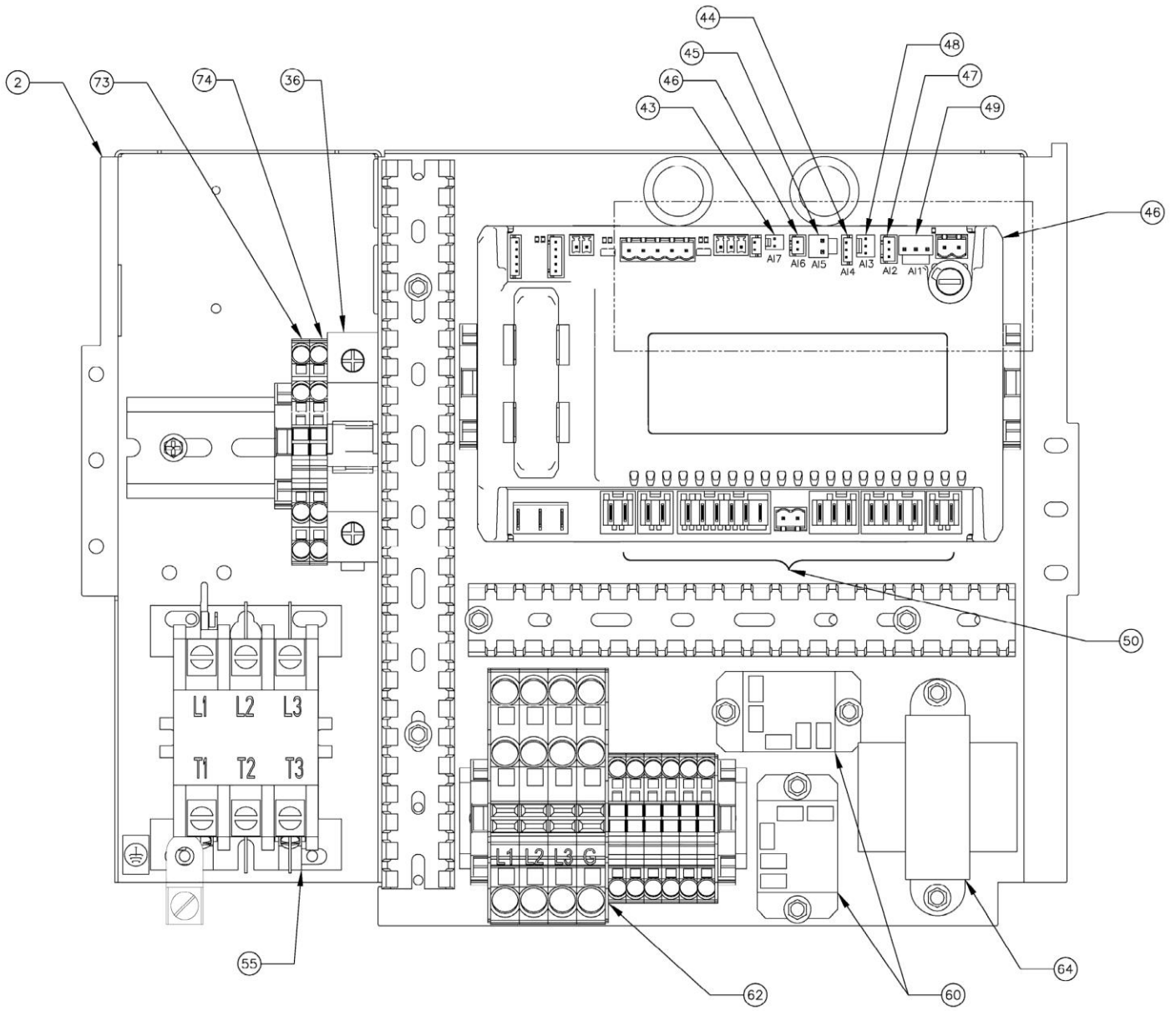

XFAL (3/4 - 1 1/4 HP) Unit Diagram

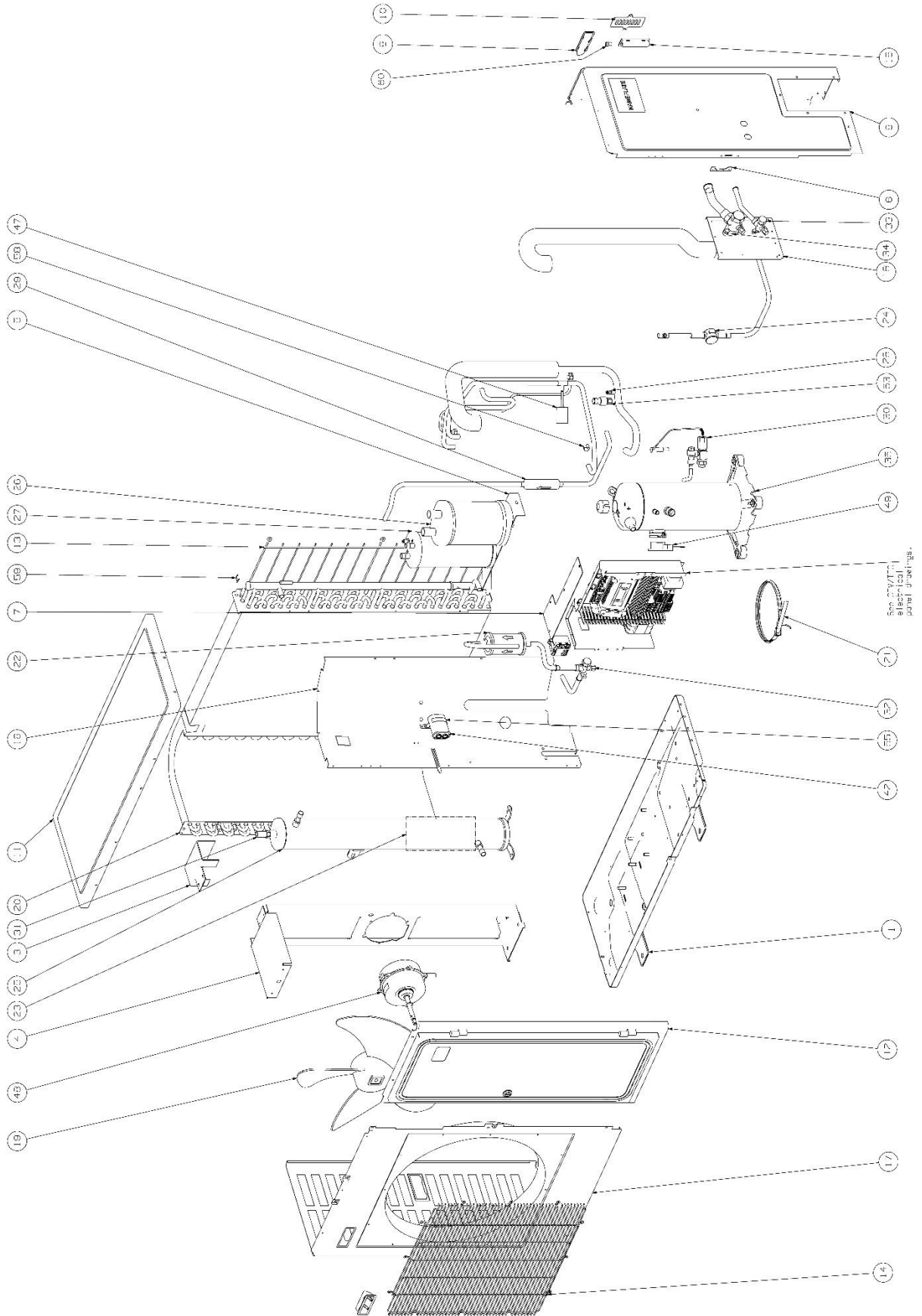

Parts List (XFAL-008Z, 009Z)

| Item | Description | XFAL-008Z-CFV-081 | XFAL-008Z-TFC-081 | XFAL-009Z-CFV-081 | XFAL-009Z-TFC-081 |
|------|--------------------------|-------------------|-------------------|-------------------|-------------------|
| 1 | BASE-PLATE | 922-0644-00 | 922-0644-00 | 922-0644-00 | 922-0644-00 |
| 2 | BOX-ELECTRICAL | 062-7053-00 | 062-7053-00 | 062-7053-00 | 062-7053-00 |
| 4 | BRACKET:STABILIZER TOP | 074-1205-00 | 074-1205-00 | 074-1205-00 | 074-1205-00 |
| 5 | BRACKET-CONTROL MTG | 074-1424-00 | 074-1424-00 | 074-1424-00 | 074-1424-00 |
| 6 | BRACKET-COVER RIGHT | 074-7284-00 | 074-7284-00 | 074-7284-00 | 074-7284-00 |
| 8 | BRACKET-MOUNTING | 074-7282-00 | 074-7282-00 | 074-7282-00 | 074-7282-00 |
| 9 | COVER-ELECTRICAL BOX | 905-7230-00 | 905-7230-00 | 905-7230-00 | 905-7230-00 |
| 10 | COVER-HANDLE | 905-7193-00 | 905-7193-00 | 905-7193-00 | 905-7193-00 |
| 11 | COVER-RIGHT | 905-1331-00 | 905-1331-00 | 905-1331-00 | 905-1331-00 |
| 12 | COVER-SENSOR | 905-1280-00 | 905-1280-00 | 905-1280-00 | 905-1280-00 |
| 13 | COVER-TOP | 905-1273-00 | 905-1273-00 | 905-1273-00 | 905-1273-00 |
| 14 | DOOR ASSEMBLY | 505-7099-00 | 505-7099-00 | 505-7099-00 | 505-7099-00 |
| 15 | GUARD-COND COIL | 924-0263-00 | 924-0263-00 | 924-0263-00 | 924-0263-00 |
| 16 | GUARD-FAN | 924-0264-00 | 924-0264-00 | 924-0264-00 | 924-0264-00 |
| 17 | HAND-GRIP | 905-7193-01 | 905-7193-01 | 905-7193-01 | 905-7193-01 |
| 18 | PLATE-DIVIDER | 903-1487-00 | 903-1487-00 | 903-1487-00 | 903-1487-00 |
| 19 | PLATE-FRONT LEFT | 905-7215-00 | 905-7215-00 | 905-7215-00 | 905-7215-00 |
| 20 | VALVE-PLATE | 903-1220-00 | 903-1220-00 | 903-1220-00 | 903-1220-00 |
| 21 | BLADE | 983-6931-00 | 983-6931-00 | 983-6931-00 | 983-6931-00 |
| 22 | CONDENSER | 066-0389-00 | 066-0389-00 | 066-0389-00 | 066-0389-00 |
| 23 | CRANKCASE HEATER ASSM. | 918-0052-05 | 918-0052-05 | 918-0052-05 | 918-0052-05 |
| 24 | FILTER-DRIER | 913-7000-31 | 913-7000-31 | 913-7000-31 | 913-7000-31 |
| 26 | HEATER - RECEIVER | 918-0100-00 | 918-0100-00 | 918-0100-00 | 918-0100-00 |
| 28 | INDICATOR-MOISTURE | 970-7003-06 | 970-7003-06 | 970-7003-06 | 970-7003-06 |
| 29 | RECEIVER ASSEMBLY | 577-0542-00 | 577-0542-00 | 577-0542-00 | 577-0542-00 |
| 30 | TANK-ACCUMULATOR | 977-0037-01 | 977-0037-01 | 977-0037-01 | 977-0037-01 |
| 31 | TANK-OIL SEPARATOR | 977-0057-00 | 977-0057-00 | 977-0057-00 | 977-0057-00 |
| 33 | VALVE-ACCESS | 910-7062-00 | 910-7062-00 | 910-7062-00 | 910-7062-00 |
| 34 | VALVE-CHECK | 910-7003-01 | 910-7003-01 | 910-7003-01 | 910-7003-01 |
| 35 | VALVE-DTC GROUP | 998-0746-00 | 998-0746-00 | 998-0746-00 | 998-0746-00 |
| 37 | VALVE-HIGH PRESSURE | 910-0730-00 | 910-0730-00 | 910-0730-00 | 910-0730-00 |
| 38 | VALVE-SERVICE (Receiver) | 910-0142-02 | 910-0142-02 | 910-0142-02 | 910-0142-02 |
| 39 | VALVE-SERVICE (Liquid) | 910-7009-01 | 910-7009-01 | 910-7009-01 | 910-7009-01 |
| 40 | VALVE-SERVICE (Suction) | 910-0180-00 | 910-0180-00 | 910-0180-00 | 910-0180-00 |
| 41 | WELD COMP | ZF03KAE-PFV-818 | ZF03KAE-TF5-818 | ZF04KAE-PFV-818 | ZF04KAE-TF5-818 |
| 42 | BREAKER-CURCUIT | 971-7018-00 | 971-7018-00 | 971-7018-00 | 971-7018-00 |
| 46 | CABLE-AMBIENT SENSOR | 929-0304-00 | 929-0304-00 | 929-0304-00 | 929-0304-00 |
| 47 | CABLE-COND TEMP SENSOR | 929-0304-00 | 929-0304-00 | 929-0304-00 | 929-0304-00 |
| 48 | CABLE-DISCH TEMP SENSOR | 929-0304-00 | 929-0304-00 | 929-0304-00 | 929-0304-00 |
| 49 | CABLE-TRANSDUCER | 529-0114-08 | 529-0114-08 | 529-0114-08 | 529-0114-08 |
| 50 | CABLE-WIRE HARNESS | 529-0222-01 | 529-0222-01 | 529-0222-01 | 529-0222-01 |
| 51 | CAPACITOR-FAN | 914-0083-00 | 914-0083-00 | 914-0083-00 | 914-0083-00 |
| 52 | CAPACITOR-RUNNING | 914-0037-11 | | 914-0037-11 | |
| 53 | CAPACITOR-STARTING | 914-0036-03 | | 914-0036-03 | |
| 55 | CONTACTOR | 912-1401-04 | 912-3040-02 | 912-1401-04 | 912-3040-02 |
| 56 | CONTROLLER-ELECT. UNIT | 943-0214-00 | 943-0214-00 | 943-0214-00 | 943-0214-00 |
| 57 | CONTROL-PRESSURE | 985-7031-06 | 985-7031-06 | 985-7031-06 | 985-7031-06 |
| 58 | MOTOR-FAN | 050-0316-01 | 050-0316-01 | 050-0316-01 | 050-0316-01 |
| 59 | POWER CABLE-MOLDED PLUG | 529-0060-04 | 529-0060-04 | 529-0060-04 | 529-0060-04 |
| 60 | RELAY-DEFROST | 940-0181-00 | 940-0181-00 | 940-0181-00 | 940-0181-00 |
| 61 | RELAY-POTENTIAL | 940-0001-79 | | 940-0001-79 | |
| 62 | TERMINAL BLOCK ASSEMBLY | 980-0086-00 | 980-0086-01 | 980-0086-00 | 980-0086-01 |
| 63 | TRANSDUCER - PRESSURE | 039-0026-06 | 039-0026-06 | 039-0026-06 | 039-0026-06 |
| 64 | TRANSFORMER CONTROL | 037-0038-01 | 037-0038-01 | 037-0038-01 | 037-0038-01 |
| 65 | CLAMP-CAPACITOR (Fan) | 032-0743-00 | 032-0743-00 | 032-0743-00 | 032-0743-00 |
| 66 | CLAMP-CAPACITOR (Run) | 032-0359-00 | | 032-0359-00 | |
| 67 | CLAMP-CAPACITOR (Start) | 032-0359-01 | | 032-0359-01 | |
| 70 | CLIP-PIPE | 032-0688-02 | 032-0688-02 | 032-0688-02 | 032-0688-02 |
| 71 | CLIP-SENSOR | 032-0731-00 | 032-0731-00 | 032-0731-00 | 032-0731-00 |
| 72 | HOLDER-SENSOR | 032-0592-00 | 032-0592-00 | 032-0592-00 | 032-0592-00 |
| 73 | BLOCK-TERMINAL - Black | 980-0139-08 | 980-0139-08 | 980-0139-08 | 980-0139-08 |
| 74 | BLOCK-TERMINAL - Red | 980-0139-09 | 980-0139-09 | 980-0139-09 | 980-0139-09 |

Parts List (XFAL-010Z, 012Z)

| Item | Description | XFAL-010Z-CFV-081 | XFAL-010Z-TFC-081 | XFAL-012Z-CFV-081 | XFAL-012Z-TFC-081 |
|------|--------------------------|-------------------|-------------------|-------------------|-------------------|
| 1 | BASE-PLATE | 922-0644-00 | 922-0644-00 | 922-0644-00 | 922-0644-00 |
| 2 | BOX-ELECTRICAL | 062-7053-00 | 062-7053-00 | 062-7053-00 | 062-7053-00 |
| 4 | BRACKET:STABILIZER TOP | 074-1205-00 | 074-1205-00 | 074-1205-00 | 074-1205-00 |
| 5 | BRACKET-CONTROL MTG | 074-1424-00 | 074-1424-00 | 074-1424-00 | 074-1424-00 |
| 6 | BRACKET-COVER RIGHT | 074-7284-00 | 074-7284-00 | 074-7284-00 | 074-7284-00 |
| 8 | BRACKET-MOUNTING | 074-7282-00 | 074-7282-00 | 074-7282-00 | 074-7282-00 |
| 9 | COVER-ELECTRICAL BOX | 905-7230-00 | 905-7230-00 | 905-7230-00 | 905-7230-00 |
| 10 | COVER-HANDLE | 905-7193-00 | 905-7193-00 | 905-7193-00 | 905-7193-00 |
| 11 | COVER-RIGHT | 905-1331-00 | 905-1331-00 | 905-1331-00 | 905-1331-00 |
| 12 | COVER-SENSOR | 905-1280-00 | 905-1280-00 | 905-1280-00 | 905-1280-00 |
| 13 | COVER-TOP | 905-1273-00 | 905-1273-00 | 905-1273-00 | 905-1273-00 |
| 14 | DOOR ASSEMBLY | 505-7099-00 | 505-7099-00 | 505-7099-00 | 505-7099-00 |
| 15 | GUARD-COND COIL | 924-0263-00 | 924-0263-00 | 924-0263-00 | 924-0263-00 |
| 16 | GUARD-FAN | 924-0264-00 | 924-0264-00 | 924-0264-00 | 924-0264-00 |
| 17 | HAND-GRIP | 905-7193-01 | 905-7193-01 | 905-7193-01 | 905-7193-01 |
| 18 | PLATE-DIVIDER | 903-1487-00 | 903-1487-00 | 903-1487-00 | 903-1487-00 |
| 19 | PLATE-FRONT LEFT | 905-7215-00 | 905-7215-00 | 905-7215-00 | 905-7215-00 |
| 20 | VALVE-PLATE | 903-1220-00 | 903-1220-00 | 903-1220-00 | 903-1220-00 |
| 21 | BLADE | 983-6931-00 | 983-6931-00 | 983-6931-00 | 983-6931-00 |
| 22 | CONDENSER | 066-0389-00 | 066-0389-00 | 066-0389-00 | 066-0389-00 |
| 23 | CRANKCASE HEATER ASSM. | 918-0052-05 | 918-0052-05 | 918-0052-05 | 918-0052-05 |
| 24 | FILTER-DRIER | 913-7000-31 | 913-7000-31 | 913-7000-31 | 913-7000-31 |
| 26 | HEATER - RECEIVER | 918-0100-00 | 918-0100-00 | 918-0100-00 | 918-0100-00 |
| 28 | INDICATOR-MOISTURE | 970-7003-06 | 970-7003-06 | 970-7003-06 | 970-7003-06 |
| 29 | RECEIVER ASSEMBLY | 577-0542-00 | 577-0542-00 | 577-0542-00 | 577-0542-00 |
| 30 | TANK-ACCUMULATOR | 977-0037-01 | 977-0037-01 | 977-0037-01 | 977-0037-01 |
| 31 | TANK-OIL SEPARATOR | 977-0057-00 | 977-0057-00 | 977-0057-00 | 977-0057-00 |
| 33 | VALVE-ACCESS | 910-7062-00 | 910-7062-00 | 910-7062-00 | 910-7062-00 |
| 34 | VALVE-CHECK | 910-7003-01 | 910-7003-01 | 910-7003-01 | 910-7003-01 |
| 35 | VALVE-DTC GROUP | 998-0746-00 | 998-0746-00 | 998-0746-00 | 998-0746-00 |
| 37 | VALVE-HIGH PRESSURE | 910-0730-00 | 910-0730-00 | 910-0730-00 | 910-0730-00 |
| 38 | VALVE-SERVICE (Receiver) | 910-0142-02 | 910-0142-02 | 910-0142-02 | 910-0142-02 |
| 39 | VALVE-SERVICE (Liquid) | 910-7009-01 | 910-7009-01 | 910-7009-01 | 910-7009-01 |
| 40 | VALVE-SERVICE (Suction) | 910-0180-00 | 910-0180-00 | 910-0180-00 | 910-0180-00 |
| 41 | WELD COMP | ZF05KAE-PFV-818 | ZF05KAE-TF5-818 | ZF07KAE-PFV-818 | ZF07KAE-TF5-818 |
| 42 | BREAKER-CURCUIT | 971-7018-00 | 971-7018-00 | 971-7018-00 | 971-7018-00 |
| 46 | CABLE-AMBIENT SENSOR | 929-0304-00 | 929-0304-00 | 929-0304-00 | 929-0304-00 |
| 47 | CABLE-COND TEMP SENSOR | 929-0304-00 | 929-0304-00 | 929-0304-00 | 929-0304-00 |
| 48 | CABLE-DISCH TEMP SENSOR | 929-0304-00 | 929-0304-00 | 929-0304-00 | 929-0304-00 |
| 49 | CABLE-TRANSDUCER | 529-0114-08 | 529-0114-08 | 529-0114-08 | 529-0114-08 |
| 50 | CABLE-WIRE HARNESS | 529-0222-01 | 529-0222-01 | 529-0222-01 | 529-0222-01 |
| 51 | CAPACITOR-FAN | 914-0083-00 | 914-0083-00 | 914-0083-00 | 914-0083-00 |
| 52 | CAPACITOR-RUNNING | 914-0037-11 | | 914-0037-36 | |
| 53 | CAPACITOR-STARTING | 914-0036-03 | | 914-0036-03 | |
| 55 | CONTACTOR | 912-1401-04 | 912-3040-02 | 912-1401-04 | 912-3040-02 |
| 56 | CONTROLLER-ELECT. UNIT | 943-0214-00 | 943-0214-00 | 943-0214-00 | 943-0214-00 |
| 57 | CONTROL-PRESSURE | 985-7031-06 | 985-7031-06 | 985-7031-06 | 985-7031-06 |
| 58 | MOTOR-FAN | 050-0316-01 | 050-0316-01 | 050-0316-01 | 050-0316-01 |
| 59 | POWER CABLE-MOLDED PLUG | 529-0060-04 | 529-0060-04 | 529-0060-04 | 529-0060-04 |
| 60 | RELAY-DEFROST | 940-0181-00 | 940-0181-00 | 940-0181-00 | 940-0181-00 |
| 61 | RELAY-POTENTIAL | 940-0001-79 | | 940-0001-79 | |
| 62 | TERMINAL BLOCK ASSEMBLY | 980-0086-00 | 980-0086-01 | 980-0086-00 | 980-0086-01 |
| 63 | TRANSDUCER - PRESSURE | 039-0026-06 | 039-0026-06 | 039-0026-06 | 039-0026-06 |
| 64 | TRANSFORMER CONTROL | 037-0038-01 | 037-0038-01 | 037-0038-01 | 037-0038-01 |
| 65 | CLAMP-CAPACITOR (Fan) | 032-0743-00 | 032-0743-00 | 032-0743-00 | 032-0743-00 |
| 66 | CLAMP-CAPACITOR (Run) | 032-0359-00 | | 032-0359-01 | |
| 67 | CLAMP-CAPACITOR (Start) | 032-0359-01 | | 032-0359-01 | |
| 70 | CLIP-PIPE | 032-0688-02 | 032-0688-02 | 032-0688-02 | 032-0688-02 |
| 71 | CLIP-SENSOR | 032-0731-00 | 032-0731-00 | 032-0731-00 | 032-0731-00 |
| 72 | HOLDER-SENSOR | 032-0592-00 | 032-0592-00 | 032-0592-00 | 032-0592-00 |
| 73 | BLOCK-TERMINAL - Black | 980-0139-08 | 980-0139-08 | 980-0139-08 | 980-0139-08 |
| 74 | BLOCK-TERMINAL - Red | 980-0139-09 | 980-0139-09 | 980-0139-09 | 980-0139-09 |

XFAL (2 - 6 HP) Unit Diagram

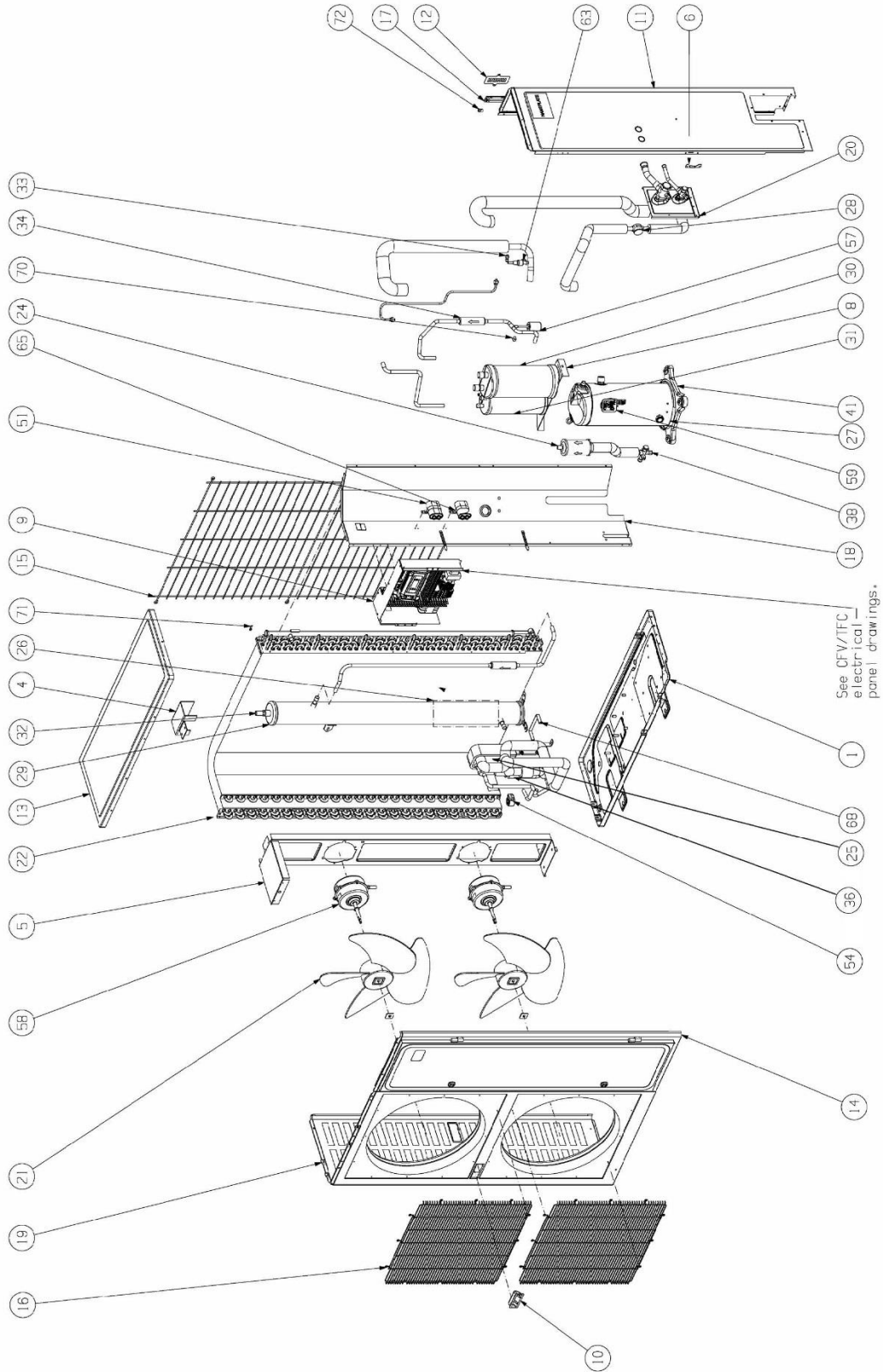

Parts List (XFAL-020Z, 030Z)

| Item | Description | XFAL-020Z-CFV-081 | XFAL-020Z-TFC-081 | XFAL-030Z-TFC-081 | XFAL-035Z-CFV-081 |
|------|----------------------------|-------------------|-------------------|-------------------|-------------------|
| 1 | BASE-PLATE | 922-0644-00 | 922-0644-00 | 922-0644-00 | 922-0644-00 |
| 2 | BOX-ELECTRICAL | 062-7053-00 | 062-7053-00 | 062-7053-00 | 062-7053-00 |
| 4 | BRACKET-STABILIZER TOP | 074-1205-00 | 074-1205-00 | 074-1205-00 | 074-1205-00 |
| 5 | BRACKET-CONTROL MTG | 074-1424-00 | 074-1424-00 | 074-1424-00 | 074-1424-00 |
| 6 | BRACKET-COVER RIGHT | 074-7284-00 | 074-7284-00 | 074-7284-00 | 074-7284-00 |
| 7 | BRACKET-HEAT EXCHANGER | 074-7283-00 | 074-7283-00 | 074-7283-00 | 074-7283-00 |
| 8 | BRACKET-MOUNTING | 074-7282-00 | 074-7282-00 | 074-7282-00 | 074-7282-00 |
| 9 | COVER-ELECTRICAL BOX | 905-7230-00 | 905-7230-00 | 905-7230-00 | 905-7230-00 |
| 10 | COVER-HANDLE | 905-7193-00 | 905-7193-00 | 905-7193-00 | 905-7193-00 |
| 11 | COVER-RIGHT | 905-1331-00 | 905-1331-00 | 905-1331-00 | 905-1331-00 |
| 12 | HAND-WIDE GRIP | 905-1280-00 | 905-1280-00 | 905-1280-00 | 905-1280-00 |
| 13 | COVER-TOP | 905-1273-00 | 905-1273-00 | 905-1273-00 | 905-1273-00 |
| 14 | DOOR ASSEMBLY | 505-7099-00 | 505-7099-00 | 505-7099-00 | 505-7099-00 |
| 15 | GUARD-COND COIL | 924-0263-00 | 924-0263-00 | 924-0263-00 | 924-0263-00 |
| 16 | GUARD-FAN | 924-0264-00 | 924-0264-00 | 924-0264-00 | 924-0264-00 |
| 17 | HAND-GRIP | 905-7193-01 | 905-7193-01 | 905-7193-01 | 905-7193-01 |
| 18 | PLATE-DIVIDER | 903-1487-00 | 903-1487-00 | 903-1487-00 | 903-1487-00 |
| 19 | PLATE-FRONT LEFT | 905-7215-00 | 905-7215-00 | 905-7215-00 | 905-7215-00 |
| 20 | VALVE-PLATE | 903-1220-00 | 903-1220-00 | 903-1220-00 | 903-1220-00 |
| 21 | BLADE | 983-6931-00 | 983-6931-00 | 983-6931-00 | 983-6931-00 |
| 22 | CONDENSER | 066-0389-00 | 066-0389-00 | 066-0800-00 | 066-0800-00 |
| 24 | FILTER-DRIER | 913-7000-31 | 913-7000-31 | 913-7000-31 | 913-7000-31 |
| 25 | HEAT EXCHANGER | 967-0025-01 | 967-0025-01 | 967-0025-01 | 967-0025-01 |
| 26 | HEATER-RECEIVER | 918-0100-00 | 918-0100-00 | 918-0100-00 | 918-0100-00 |
| 27 | HEATER-CRANKCASE | 918-0052-05 | 918-0052-05 | 918-0052-05 | 918-0043-00 |
| 28 | INDICATOR-MOISTURE | 970-7003-06 | 970-7003-06 | 970-7003-06 | 970-7003-06 |
| 29 | RECEIVER ASSEMBLY | 577-0542-00 | 577-0542-00 | 577-0542-00 | 577-0542-00 |
| 30 | TANK-ACCUMULATOR | 977-0037-01 | 977-0037-01 | 977-0037-01 | 977-0037-01 |
| 31 | TANK-OIL SEPARATOR | 977-0057-00 | 977-0057-00 | 977-0057-00 | 977-0057-00 |
| 32 | Valve - Pressure Relief | 910-0730-00 | 910-0730-00 | 910-0730-00 | 910-0730-00 |
| 33 | VALVE-ACCESS | 910-7062-00 | 910-7062-00 | 910-7062-00 | 910-7062-00 |
| 34 | VALVE-CHECK | 910-7003-01 | 910-7003-01 | 910-7003-01 | 910-7003-01 |
| 36 | VALVE-EXV | 910-0104-00 | 910-0104-00 | 910-0104-00 | 910-0104-00 |
| 38 | VALVE-SERVICE (Receiver) | 910-0142-02 | 910-0142-02 | 910-0142-02 | 910-0142-02 |
| 39 | VALVE-SERVICE (Liquid) | 910-7009-01 | 910-7009-01 | 910-7009-01 | 910-7009-01 |
| 40 | VALVE-SERVICE (Suction) | 910-0180-00 | 910-0180-00 | 910-0180-00 | 910-0180-00 |
| 41 | WELD COMP | ZX106KCE-PFV-887 | ZX106KCE-TF5-887 | ZX109KCE-TF5-887 | ZX111KCE-PFV-847 |
| 42 | BREAKER-CURCUIT | 971-7018-00 | 971-7018-00 | 971-7018-00 | 971-7018-00 |
| 43 | CABLE- LIQUID LINE SENSOR | | | | |
| 44 | CABLE- VAPOR INLET SENSOR | 929-0304-00 | 929-0304-00 | 929-0304-00 | 929-0304-00 |
| 45 | CABLE- VAPOR OUTLET SENSOR | 929-0304-00 | 929-0304-00 | 929-0304-00 | 929-0304-00 |
| 46 | CABLE-AMBIENT SENSOR | 929-0304-00 | 929-0304-00 | 929-0304-00 | 929-0304-00 |
| 47 | CABLE-COND TEMP SENSOR | 929-0304-00 | 929-0304-00 | 929-0304-00 | 929-0304-00 |
| 48 | CABLE-DISCH TEMP SENSOR | 929-0304-00 | 929-0304-00 | 929-0304-00 | 929-0304-00 |
| 49 | CABLE-TRANSDUCER | 529-0114-08 | 529-0114-08 | 529-0114-08 | 529-0114-08 |
| 50 | CABLE-WIRE HARNESS | 529-0222-01 | 529-0222-01 | 529-0222-01 | 529-0222-01 |
| 51 | CAPACITOR-FAN | 914-0083-00 | 914-0083-00 | 914-0083-00 | 914-0083-00 |
| 52 | CAPACITOR-RUNNING | 914-0037-36 | | | 914-0037-22 |
| 53 | CAPACITOR-START | 914-0036-03 | | | 914-0036-03 |
| 54 | COIL-EXV | 923-0068-00 | 923-0068-00 | 923-0068-00 | 923-0068-00 |
| 55 | CONTACTOR | 912-1401-04 | 912-3040-02 | 912-3040-02 | 912-1401-04 |
| 56 | CONTROLLER-ELECT. UNIT | 943-0214-00 | 943-0214-00 | 943-0214-00 | 943-0214-00 |
| 57 | CONTROL-PRESSURE | 985-7031-06 | 985-7031-06 | 985-7031-06 | 985-7031-06 |
| 58 | MOTOR-FAN | 050-0316-01 | 050-0316-01 | 050-0316-01 | 050-0316-01 |
| 59 | POWER CABLE-MOLDED PLUG | 529-0060-04 | 529-0060-04 | 529-0060-04 | 529-0060-04 |
| 60 | RELAY-DEFROST | 940-0181-00 | 940-0181-00 | 940-0181-00 | 940-0181-00 |
| 61 | RELAY-POTENTIAL | 940-0001-79 | | | 940-0001-79 |
| 62 | TERMINAL BLOCK ASSEMBLY | 980-0086-00 | 980-0086-01 | 980-0086-01 | 980-0086-00 |
| 63 | TRANSDUCER - PRESSURE | 039-0026-06 | 039-0026-06 | 039-0026-06 | 039-0026-06 |
| 64 | TRANSFORMER CONTROL | 037-0038-01 | 037-0038-01 | 037-0038-01 | 037-0038-01 |
| 65 | CLAMP-CAPACITOR (Fan) | 032-0743-00 | 032-0743-00 | 032-0743-00 | 032-0743-00 |
| 66 | CLAMP-CAPACITOR (Run) | 032-0359-01 | | | 032-0359-02 |
| 67 | CLAMP-CAPACITOR (Start) | 032-0359-01 | | | 032-0359-01 |
| 68 | CLAMP-HEAT EXCHANGER | 032-7052-00 | 032-7052-00 | 032-7052-00 | 032-7052-00 |
| 70 | CLIP-PIPE | 032-0688-02 | 032-0688-02 | 032-0688-02 | 032-0688-02 |
| 71 | CLIP-DIVIDER PLATE | 032-0731-00 | 032-0731-00 | 032-0731-00 | 032-0731-00 |
| 72 | HOLDER-SENSOR | 032-0592-00 | 032-0592-00 | 032-0592-00 | 032-0592-00 |
| 73 | BLOCK-TERMINAL - Black | 980-0139-08 | 980-0139-08 | 980-0139-08 | 980-0139-08 |
| 74 | BLOCK-TERMINAL - Red | 980-0139-09 | 980-0139-09 | 980-0139-09 | 980-0139-09 |

Parts List (XFAL-040Z, 050Z, 051Z, 060Z)

| Item | Description | XFAL-040Z-CFV-081 | XFAL-040Z-TFC-081 | XFAL-050Z-TFC-081 | XFAL-051Z-CFV-081 | XFAL-060Z-TFC-081 |
|------|----------------------------|-------------------|-------------------|-------------------|-------------------|-------------------|
| 1 | BASE-PLATE | 922-0644-00 | 922-0644-00 | 922-0644-00 | 922-0644-00 | 922-0644-00 |
| 2 | BOX-ELECTRICAL | 062-7053-00 | 062-7053-00 | 062-7053-00 | 062-7053-00 | 062-7053-00 |
| 4 | BRACKET-STABILIZER TOP | 074-1205-00 | 074-1205-00 | 074-1205-00 | 074-1205-00 | 074-1205-00 |
| 5 | BRACKET-CONTROL MTG | 074-1425-00 | 074-1425-00 | 074-1425-00 | 074-1425-00 | 074-1425-00 |
| 6 | BRACKET-COVER RIGHT | 074-7284-00 | 074-7284-00 | 074-7284-00 | 074-7284-00 | 074-7284-00 |
| 7 | BRACKET-HEAT EXCHANGER | 074-7283-00 | 074-7283-00 | 074-7283-00 | 074-7283-00 | 074-7283-00 |
| 8 | BRACKET-MOUNTING | 074-7282-00 | 074-7282-00 | 074-7282-00 | 074-7282-00 | 074-7282-00 |
| 9 | COVER-ELECTRICAL BOX | 905-7230-00 | 905-7230-00 | 905-7230-00 | 905-7230-00 | 905-7230-00 |
| 10 | COVER-HANDLE | 905-7193-00 | 905-7193-00 | 905-7193-00 | 905-7193-00 | 905-7193-00 |
| 11 | COVER-RIGHT | 905-1332-00 | 905-1332-00 | 905-1332-00 | 905-1332-00 | 905-1332-00 |
| 12 | HAND-WIDE GRIP | 905-1280-00 | 905-1280-00 | 905-1280-00 | 905-1280-00 | 905-1280-00 |
| 13 | COVER-TOP | 905-1273-00 | 905-1273-00 | 905-1273-00 | 905-1273-00 | 905-1273-00 |
| 14 | DOOR ASSEMBLY | 505-7098-00 | 505-7098-00 | 505-7098-00 | 505-7098-00 | 505-7098-00 |
| 15 | GUARD-COND COIL | 924-0262-00 | 924-0262-00 | 924-0262-00 | 924-0262-00 | 924-0262-00 |
| 16 | GUARD-FAN | 924-0264-00 | 924-0264-00 | 924-0264-00 | 924-0264-00 | 924-0264-00 |
| 17 | HAND-GRIP | 905-7193-01 | 905-7193-01 | 905-7193-01 | 905-7193-01 | 905-7193-01 |
| 18 | PLATE-DIVIDER | 903-1576-00 | 903-1576-00 | 903-1576-00 | 903-1576-00 | 903-1576-00 |
| 19 | PLATE-FRONT LEFT | 905-7214-00 | 905-7214-00 | 905-7214-00 | 905-7214-00 | 905-7214-00 |
| 20 | VALVE-PLATE | 903-1220-00 | 903-1220-00 | 903-1220-00 | 903-1220-00 | 903-1220-00 |
| 21 | BLADE | 983-6931-00 | 983-6931-00 | 983-6931-00 | 983-6931-00 | 983-6931-00 |
| 22 | CONDENSER | 066-0388-00 | 066-0388-00 | 066-0387-00 | 066-0387-00 | 066-0393-00 |
| 24 | FILTER-DRIER | 913-7000-31 | 913-7000-31 | 913-7000-31 | 913-7000-31 | 913-7000-31 |
| 25 | HEAT EXCHANGER | 967-0025-00 | 967-0025-00 | 967-0025-00 | 967-0025-00 | 967-0025-00 |
| 26 | HEATER-RECEIVER | 918-0100-00 | 918-0100-00 | 918-0100-00 | 918-0100-00 | 918-0100-00 |
| 27 | HEATER-CRANKCASE | 918-0043-00 | 918-0043-00 | 918-0043-00 | 918-0043-00 | 918-0043-00 |
| 28 | INDICATOR-MOISTURE | 970-7003-06 | 970-7003-06 | 970-7003-06 | 970-7003-06 | 970-7003-06 |
| 29 | RECEIVER ASSEMBLY | 577-0542-01 | 577-0542-01 | 577-0542-01 | 577-0542-01 | 577-0542-01 |
| 30 | TANK-ACCUMULATOR | 977-0036-01 | 977-0036-01 | 977-0036-01 | 977-0036-01 | 977-0036-01 |
| 31 | TANK-OIL SEPARATOR | 977-0057-00 | 977-0057-00 | 977-0057-00 | 977-0057-00 | 977-0057-00 |
| 32 | Valve - Pressure Relief | 910-0730-00 | 910-0730-00 | 910-0730-00 | 910-0730-00 | 910-0730-00 |
| 33 | VALVE-ACCESS | 910-7062-00 | 910-7062-00 | 910-7062-00 | 910-7062-00 | 910-7062-00 |
| 34 | VALVE-CHECK | 910-7003-01 | 910-7003-01 | 910-7003-01 | 910-7003-01 | 910-7003-01 |
| 36 | VALVE-EXV | 910-0104-00 | 910-0104-00 | 910-0104-00 | 910-0104-00 | 910-0104-00 |
| 38 | VALVE-SERVICE (Receiver) | 910-0142-02 | 910-0142-02 | 910-0142-02 | 910-0142-02 | 910-0142-02 |
| 39 | VALVE-SERVICE (Liquid) | 910-7009-01 | 910-7009-01 | 910-7009-01 | 910-7009-01 | 910-7009-01 |
| 40 | VALVE-SERVICE (Suction) | 910-0180-00 | 910-0180-00 | 910-0180-00 | 910-0180-00 | 910-0180-00 |
| 41 | WELD COMP | ZX114KCE-PFV-847 | ZX114KCE-TF5-847 | ZX115KCE-TF5-847 | ZX116KCE-PFV-957 | ZX118KCE-TF5-957 |
| 42 | BREAKER-CURCUIT | 971-7018-00 | 971-7018-00 | 971-7018-00 | 971-7018-00 | 971-7018-00 |
| 43 | CABLE- LIQUID LINE SENSOR | 929-0304-00 | 929-0304-00 | 929-0304-00 | 929-0304-00 | 929-0304-00 |
| 44 | CABLE- VAPOR INLET SENSOR | 929-0304-00 | 929-0304-00 | 929-0304-00 | 929-0304-00 | 929-0304-00 |
| 45 | CABLE- VAPOR OUTLET SENSOR | 929-0304-00 | 929-0304-00 | 929-0304-00 | 929-0304-00 | 929-0304-00 |
| 46 | CABLE-AMBIENT SENSOR | 929-0304-00 | 929-0304-00 | 929-0304-00 | 929-0304-00 | 929-0304-00 |
| 47 | CABLE-COND TEMP SENSOR | 929-0304-00 | 929-0304-00 | 929-0304-00 | 929-0304-00 | 929-0304-00 |
| 48 | CABLE-DISCH TEMP SENSOR | 929-0304-00 | 929-0304-00 | 929-0304-00 | 929-0304-00 | 929-0304-00 |
| 49 | CABLE-TRANSDUCER | 529-0114-08 | 529-0114-08 | 529-0114-08 | 529-0114-08 | 529-0114-08 |
| 50 | CABLE-WIRE HARNESS | 529-0222-02 | 529-0222-02 | 529-0222-02 | 529-0222-02 | 529-0222-02 |
| 51 | CAPACITOR-FAN | 914-0083-00 | 914-0083-00 | 914-0083-00 | 914-0083-00 | 914-0083-00 |
| 52 | CAPACITOR-RUNNING | 914-0037-38 | | | 914-0037-52 | |
| 53 | CAPACITOR-START | 914-0036-03 | | | 914-0006-10 | |
| 54 | COIL-EXV | 923-0068-00 | 923-0068-00 | 923-0068-00 | 923-0068-00 | 923-0068-00 |
| 55 | CONTACTOR | 912-1401-04 | 912-3040-02 | 912-3040-02 | 912-1401-04 | 912-3040-02 |
| 56 | CONTROLLER-ELECT. UNIT | 943-0214-00 | 943-0214-00 | 943-0214-00 | 943-0214-00 | 943-0214-00 |
| 57 | CONTROL-PRESSURE | 985-7031-06 | 985-7031-06 | 985-7031-06 | 985-7031-06 | 985-7031-06 |
| 58 | MOTOR-FAN | 050-0316-01 | 050-0316-01 | 050-0316-01 | 050-0316-01 | 050-0316-01 |
| 59 | POWER CABLE-MOLDED PLUG | 529-0060-25 | 529-0060-25 | 529-0060-25 | | |
| 60 | RELAY-DEFROST | 940-0181-00 | 940-0181-00 | 940-0181-00 | 940-0181-00 | 940-0181-00 |
| 61 | RELAY-POTENTIAL | 940-0001-79 | | | 940-0046-24 | |
| 62 | TERMINAL BLOCK ASSEMBLY | 980-0086-00 | 980-0086-01 | 980-0086-01 | 980-0086-00 | 980-0086-01 |
| 63 | TRANSDUCER - PRESSURE | 039-0026-06 | 039-0026-06 | 039-0026-06 | 039-0026-06 | 039-0026-06 |
| 64 | TRANSFORMER CONTROL | 037-0038-01 | 037-0038-01 | 037-0038-01 | 037-0038-01 | 037-0038-01 |
| 65 | CLAMP-CAPACITOR (Fan) | 032-0743-00 | 032-0743-00 | 032-0743-00 | 032-0743-00 | 032-0743-00 |
| 66 | CLAMP-CAPACITOR (Run) | 032-0359-01 | | | 032-0359-02 | |
| 67 | CLAMP-CAPACITOR (Start) | 032-0359-01 | | | 032-0359-01 | |
| 68 | CLAMP-HEAT EXCHANGER | 032-7052-00 | 032-7052-00 | 032-7052-00 | 032-7052-00 | 032-7052-00 |
| 70 | CLIP-PIPE | 032-0688-02 | 032-0688-02 | 032-0688-02 | 032-0688-02 | 032-0688-02 |
| 71 | CLIP-DIVIDER PLATE | 032-0731-00 | 032-0731-00 | 032-0731-00 | 032-0731-00 | 032-0731-00 |
| 72 | HOLDER-SENSOR | 032-0592-00 | 032-0592-00 | 032-0592-00 | 032-0592-00 | 032-0592-00 |
| 73 | BLOCK-TERMINAL - Black | 980-0139-08 | 980-0139-08 | 980-0139-08 | 980-0139-08 | 980-0139-08 |
| 74 | BLOCK-TERMINAL - Red | 980-0139-09 | 980-0139-09 | 980-0139-09 | 980-0139-09 | 980-0139-09 |

XFAM / XFAP Unit Diagram

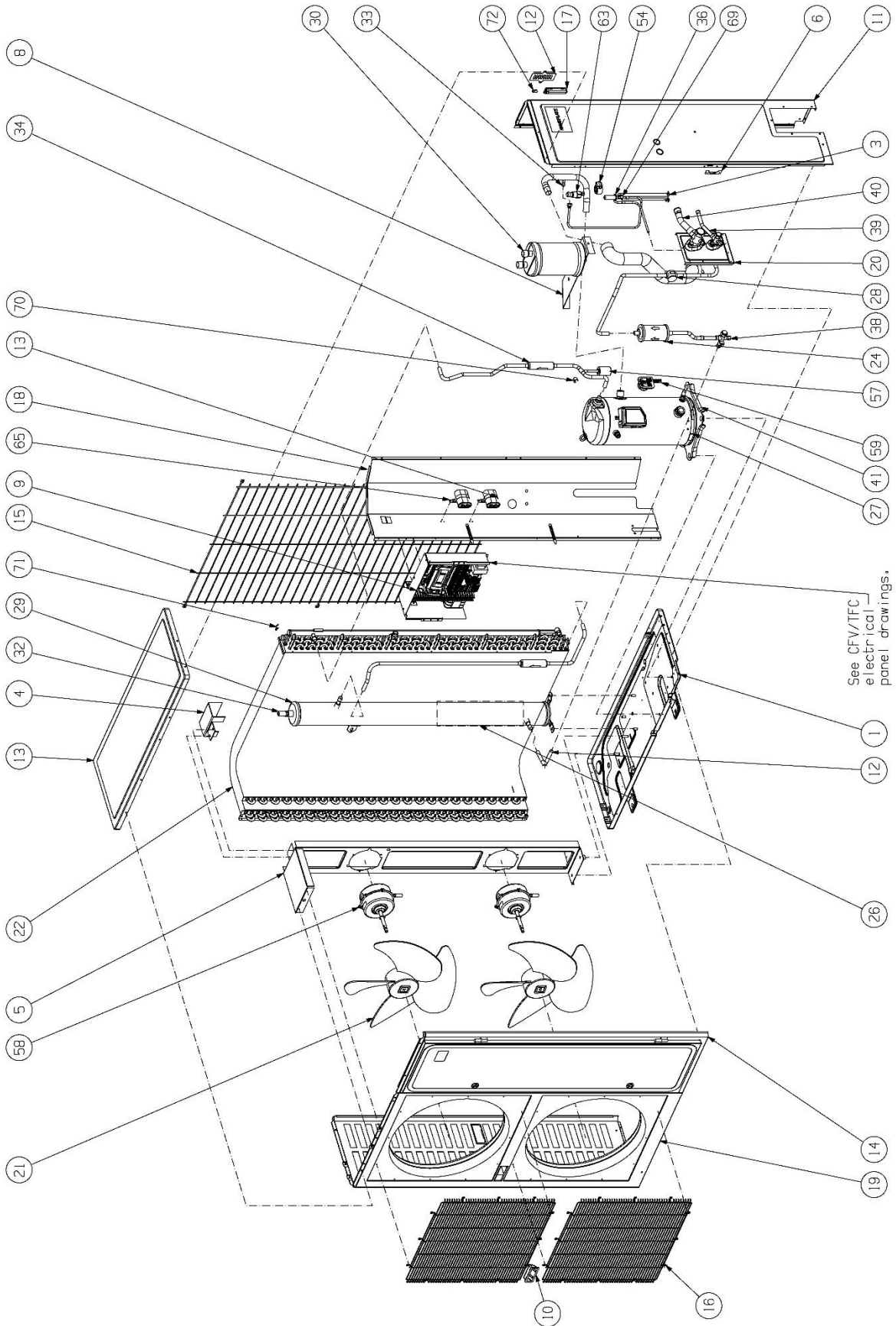

Parts List (XFAM-008Z, 010Z)

| Item | Description | XFAM-008Z-CFV-081 | XFAM-008Z-TFC-081 | XFAM-010Z-CFV-081 | XFAM-010Z-TFC-081 |
|------|--------------------------|-------------------|-------------------|-------------------|-------------------|
| 1 | BASE-PLATE | 922-0644-00 | 922-0644-00 | 922-0644-00 | 922-0644-00 |
| 2 | BOX-ELECTRICAL | 062-7053-00 | 062-7053-00 | 062-7053-00 | 062-7053-00 |
| 3 | BRACKET:EXV | 074-1207-01 | 074-1207-01 | 074-1207-01 | 074-1207-01 |
| 4 | BRACKET:STABILIZER TOP | 074-1205-00 | 074-1205-00 | 074-1205-00 | 074-1205-00 |
| 5 | BRACKET-CONTROL MTG | 074-1424-00 | 074-1424-00 | 074-1424-00 | 074-1424-00 |
| 6 | BRACKET-COVER RIGHT | 074-7284-00 | 074-7284-00 | 074-7284-00 | 074-7284-00 |
| 9 | COVER-ELECTRICAL BOX | 905-7230-00 | 905-7230-00 | 905-7230-00 | 905-7230-00 |
| 10 | COVER-HANDLE | 905-7193-00 | 905-7193-00 | 905-7193-00 | 905-7193-00 |
| 11 | COVER-RIGHT | 905-1331-00 | 905-1331-00 | 905-1331-00 | 905-1331-00 |
| 12 | HAND-WIDE GRIP | 905-1280-00 | 905-1280-00 | 905-1280-00 | 905-1280-00 |
| 13 | COVER-TOP | 905-1273-00 | 905-1273-00 | 905-1273-00 | 905-1273-00 |
| 14 | DOOR ASSEMBLY | 505-7099-00 | 505-7099-00 | 505-7099-00 | 505-7099-00 |
| 15 | GUARD-COND COIL | 924-0263-00 | 924-0263-00 | 924-0263-00 | 924-0263-00 |
| 16 | GUARD-FAN | 924-0264-00 | 924-0264-00 | 924-0264-00 | 924-0264-00 |
| 17 | HAND-GRIP | 905-7193-01 | 905-7193-01 | 905-7193-01 | 905-7193-01 |
| 18 | PLATE-DIVIDER | 903-1487-00 | 903-1487-00 | 903-1487-00 | 903-1487-00 |
| 19 | PLATE-FRONT LEFT | 905-7215-00 | 905-7215-00 | 905-7215-00 | 905-7215-00 |
| 20 | VALVE-PLATE | 903-1220-00 | 903-1220-00 | 903-1220-00 | 903-1220-00 |
| 21 | BLADE | 983-6931-00 | 983-6931-00 | 983-6931-00 | 983-6931-00 |
| 22 | CONDENSER | 066-0389-00 | 066-0389-00 | 066-0389-00 | 066-0389-00 |
| 24 | FILTER-DRIER | 913-7000-31 | 913-7000-31 | 913-7000-31 | 913-7000-31 |
| 26 | HEATER-RECEIVER | 918-0100-00 | 918-0100-00 | 918-0100-00 | 918-0100-00 |
| 27 | HEATER-CRANKCASE | 918-0052-05 | 918-0052-05 | 918-0052-05 | 918-0052-05 |
| 28 | INDICATOR-MOISTURE | 970-7003-06 | 970-7003-06 | 970-7003-06 | 970-7003-06 |
| 29 | RECEIVER ASSEMBLY | 577-0542-00 | 577-0542-00 | 577-0542-00 | 577-0542-00 |
| 32 | Valve - Pressure Relief | 910-0730-00 | 910-0730-00 | 910-0730-00 | 910-0730-00 |
| 33 | VALVE-ACCESS | 910-7062-00 | 910-7062-00 | 910-7062-00 | 910-7062-00 |
| 34 | VALVE-CHECK | 910-7003-01 | 910-7003-01 | 910-7003-01 | 910-7003-01 |
| 36 | VALVE-EXV | 910-0104-00 | 910-0104-00 | 910-0104-00 | 910-0104-00 |
| 38 | VALVE-SERVICE (Receiver) | 910-0142-02 | 910-0142-02 | 910-0142-02 | 910-0142-02 |
| 39 | VALVE-SERVICE (Liquid) | 910-7009-01 | 910-7009-01 | 910-7009-01 | 910-7009-01 |
| 40 | VALVE-SERVICE (Suction) | 910-0180-00 | 910-0180-00 | 910-0180-00 | 910-0180-00 |
| 41 | WELD COMP | ZB06KAE-PFV-818 | ZB06KAE-TF5-818 | ZB07KAE-PFV-818 | ZB07KAE-TF5-818 |
| 42 | BREAKER-CURCUIT | 971-7018-00 | 971-7018-00 | 971-7018-00 | 971-7018-00 |
| 46 | CABLE-AMBIENT SENSOR | 929-0304-00 | 929-0304-00 | 929-0304-00 | 929-0304-00 |
| 47 | CABLE-COND TEMP SENSOR | 929-0304-00 | 929-0304-00 | 929-0304-00 | 929-0304-00 |
| 48 | CABLE-DISCH TEMP SENSOR | 929-0304-00 | 929-0304-00 | 929-0304-00 | 929-0304-00 |
| 49 | CABLE-TRANSDUCER | 529-0114-08 | 529-0114-08 | 529-0114-08 | 529-0114-08 |
| 50 | CABLE-WIRE HARNESS | 529-0222-01 | 529-0222-01 | 529-0222-01 | 529-0222-01 |
| 51 | CAPACITOR-FAN | 914-0083-00 | 914-0083-00 | 914-0083-00 | 914-0083-00 |
| 52 | CAPACITOR-RUNNING | 914-0037-11 | | 914-0037-11 | |
| 53 | CAPACITOR-START | 914-0036-03 | | 914-0036-03 | |
| 54 | COIL-EXV | 923-0068-00 | 923-0068-00 | 923-0068-00 | 923-0068-00 |
| 55 | CONTACTOR | 912-1401-04 | 912-3040-02 | 912-1401-04 | 912-3040-02 |
| 56 | CONTROLLER-ELECT. UNIT | 943-0214-00 | 943-0214-00 | 943-0214-00 | 943-0214-00 |
| 57 | CONTROL-PRESSURE | 985-7031-06 | 985-7031-06 | 985-7031-06 | 985-7031-06 |
| 58 | MOTOR-FAN | 050-0316-01 | 050-0316-01 | 050-0316-01 | 050-0316-01 |
| 59 | POWER CABLE-MOLDED PLUG | 529-0060-04 | 529-0060-04 | 529-0060-04 | 529-0060-04 |
| 60 | RELAY-DEFROST | 940-0181-00 | 940-0181-00 | 940-0181-00 | 940-0181-00 |
| 61 | RELAY-POTENTIAL | 940-0001-79 | | 940-0001-79 | |
| 62 | TERMINAL BLOCK ASSEMBLY | 980-0086-00 | 980-0086-01 | 980-0086-00 | 980-0086-01 |
| 63 | TRANSDUCER - PRESSURE | 039-0026-06 | 039-0026-06 | 039-0026-06 | 039-0026-06 |
| 64 | TRANSFORMER CONTROL | 037-0038-01 | 037-0038-01 | 037-0038-01 | 037-0038-01 |
| 65 | CLAMP-CAPACITOR (Fan) | 032-0743-00 | 032-0743-00 | 032-0743-00 | 032-0743-00 |
| 66 | CLAMP-CAPACITOR (Run) | 032-0359-00 | | 032-0359-00 | |
| 67 | CLAMP-CAPACITOR (Start) | 032-0359-01 | | 032-0359-01 | |
| 69 | CLAMP-TUBE | 032-7003-06 | 032-7003-06 | 032-7003-06 | 032-7003-06 |
| 70 | CLIP-PIPE | 032-0688-02 | 032-0688-02 | 032-0688-02 | 032-0688-02 |
| 71 | CLIP-DIVIDER PLATE | 032-0731-00 | 032-0731-00 | 032-0731-00 | 032-0731-00 |
| 72 | HOLDER-SENSOR | 032-0592-00 | 032-0592-00 | 032-0592-00 | 032-0592-00 |
| 73 | BLOCK-TERMINAL - Black | 980-0139-08 | 980-0139-08 | 980-0139-08 | 980-0139-08 |
| 74 | BLOCK-TERMINAL - Red | 980-0139-09 | 980-0139-09 | 980-0139-09 | 980-0139-09 |

Parts List (XFAM-012Z, 015Z)

| Item | Description | XFAM-012Z-CFV-081 | XFAM-012Z-TFC-081 | XFAM-015Z-CFV-081 | XFAM-015Z-TFC-081 |
|------|--------------------------|-------------------|-------------------|-------------------|-------------------|
| 1 | BASE-PLATE | 922-0644-00 | 922-0644-00 | 922-0644-00 | 922-0644-00 |
| 2 | BOX-ELECTRICAL | 062-7053-00 | 062-7053-00 | 062-7053-00 | 062-7053-00 |
| 3 | BRACKET:EXV | 074-1207-01 | 074-1207-01 | 074-1207-01 | 074-1207-01 |
| 4 | BRACKET:STABILIZER TOP | 074-1205-00 | 074-1205-00 | 074-1205-00 | 074-1205-00 |
| 5 | BRACKET-CONTROL MTG | 074-1424-00 | 074-1424-00 | 074-1424-00 | 074-1424-00 |
| 6 | BRACKET-COVER RIGHT | 074-7284-00 | 074-7284-00 | 074-7284-00 | 074-7284-00 |
| 9 | COVER-ELECTRICAL BOX | 905-7230-00 | 905-7230-00 | 905-7230-00 | 905-7230-00 |
| 10 | COVER-HANDLE | 905-7193-00 | 905-7193-00 | 905-7193-00 | 905-7193-00 |
| 11 | COVER-RIGHT | 905-1331-00 | 905-1331-00 | 905-1331-00 | 905-1331-00 |
| 12 | HAND-WIDE GRIP | 905-1280-00 | 905-1280-00 | 905-1280-00 | 905-1280-00 |
| 13 | COVER-TOP | 905-1273-00 | 905-1273-00 | 905-1273-00 | 905-1273-00 |
| 14 | DOOR ASSEMBLY | 505-7099-00 | 505-7099-00 | 505-7099-00 | 505-7099-00 |
| 15 | GUARD-COND COIL | 924-0263-00 | 924-0263-00 | 924-0263-00 | 924-0263-00 |
| 16 | GUARD-FAN | 924-0264-00 | 924-0264-00 | 924-0264-00 | 924-0264-00 |
| 17 | HAND-GRIP | 905-7193-01 | 905-7193-01 | 905-7193-01 | 905-7193-01 |
| 18 | PLATE-DIVIDER | 903-1487-00 | 903-1487-00 | 903-1487-00 | 903-1487-00 |
| 19 | PLATE-FRONT LEFT | 905-7215-00 | 905-7215-00 | 905-7215-00 | 905-7215-00 |
| 20 | VALVE-PLATE | 903-1220-00 | 903-1220-00 | 903-1220-00 | 903-1220-00 |
| 21 | BLADE | 983-6931-00 | 983-6931-00 | 983-6931-00 | 983-6931-00 |
| 22 | CONDENSER | 066-0389-00 | 066-0389-00 | 066-0389-00 | 066-0389-00 |
| 24 | FILTER-DRIER | 913-7000-31 | 913-7000-31 | 913-7000-31 | 913-7000-31 |
| 26 | HEATER-RECEIVER | 918-0100-00 | 918-0100-00 | 918-0100-00 | 918-0100-00 |
| 27 | HEATER-CRANKCASE | 918-0052-05 | 918-0052-05 | 918-0052-05 | 918-0052-05 |
| 28 | INDICATOR-MOISTURE | 970-7003-06 | 970-7003-06 | 970-7003-06 | 970-7003-06 |
| 29 | RECEIVER ASSEMBLY | 577-0542-00 | 577-0542-00 | 577-0542-00 | 577-0542-00 |
| 32 | Valve - Pressure Relief | 910-0730-00 | 910-0730-00 | 910-0730-00 | 910-0730-00 |
| 33 | VALVE-ACCESS | 910-7062-00 | 910-7062-00 | 910-7062-00 | 910-7062-00 |
| 34 | VALVE-CHECK | 910-7003-01 | 910-7003-01 | 910-7003-01 | 910-7003-01 |
| 36 | VALVE-EXV | 910-0104-00 | 910-0104-00 | 910-0104-00 | 910-0104-00 |
| 38 | VALVE-SERVICE (Receiver) | 910-0142-02 | 910-0142-02 | 910-0142-02 | 910-0142-02 |
| 39 | VALVE-SERVICE (Liquid) | 910-7009-01 | 910-7009-01 | 910-7009-01 | 910-7009-01 |
| 40 | VALVE-SERVICE (Suction) | 910-0180-00 | 910-0180-00 | 910-0180-00 | 910-0180-00 |
| 41 | WELD COMP | ZB08KAE-PFV-818 | ZB08KAE-TF5-818 | ZS09KAE-PFV-818 | ZS09KAE-TF5-818 |
| 42 | BREAKER-CURCUIT | 971-7018-00 | 971-7018-00 | 971-7018-00 | 971-7018-00 |
| 46 | CABLE-AMBIENT SENSOR | 929-0304-00 | 929-0304-00 | 929-0304-00 | 929-0304-00 |
| 47 | CABLE-COND TEMP SENSOR | 929-0304-00 | 929-0304-00 | 929-0304-00 | 929-0304-00 |
| 48 | CABLE-DISCH TEMP SENSOR | 929-0304-00 | 929-0304-00 | 929-0304-00 | 929-0304-00 |
| 49 | CABLE-TRANSDUCER | 529-0114-08 | 529-0114-08 | 529-0114-08 | 529-0114-08 |
| 50 | CABLE-WIRE HARNESS | 529-0222-01 | 529-0222-01 | 529-0222-01 | 529-0222-01 |
| 51 | CAPACITOR-FAN | 914-0083-00 | 914-0083-00 | 914-0083-00 | 914-0083-00 |
| 52 | CAPACITOR-RUNNING | 914-0037-11 | | 914-0037-10 | |
| 53 | CAPACITOR-START | 914-0036-03 | | 914-0036-03 | |
| 54 | COIL-EXV | 923-0068-00 | 923-0068-00 | 923-0068-00 | 923-0068-00 |
| 55 | CONTACTOR | 912-1401-04 | 912-3040-02 | 912-1401-04 | 912-3040-02 |
| 56 | CONTROLLER-ELECT. UNIT | 943-0214-00 | 943-0214-00 | 943-0214-00 | 943-0214-00 |
| 57 | CONTROL-PRESSURE | 985-7031-06 | 985-7031-06 | 985-7031-06 | 985-7031-06 |
| 58 | MOTOR-FAN | 050-0316-01 | 050-0316-01 | 050-0316-01 | 050-0316-01 |
| 59 | POWER CABLE-MOLDED PLUG | 529-0060-04 | 529-0060-04 | 529-0060-04 | 529-0060-04 |
| 60 | RELAY-DEFROST | 940-0181-00 | 940-0181-00 | 940-0181-00 | 940-0181-00 |
| 61 | RELAY-POTENTIAL | 940-0001-79 | | 940-0001-79 | |
| 62 | TERMINAL BLOCK ASSEMBLY | 980-0086-00 | 980-0086-01 | 980-0086-00 | 980-0086-01 |
| 63 | TRANSDUCER - PRESSURE | 039-0026-06 | 039-0026-06 | 039-0026-06 | 039-0026-06 |
| 64 | TRANSFORMER CONTROL | 037-0038-01 | 037-0038-01 | 037-0038-01 | 037-0038-01 |
| 65 | CLAMP-CAPACITOR (Fan) | 032-0743-00 | 032-0743-00 | 032-0743-00 | 032-0743-00 |
| 66 | CLAMP-CAPACITOR (Run) | 032-0359-00 | | 032-0359-00 | |
| 67 | CLAMP-CAPACITOR (Start) | 032-0359-01 | | 032-0359-01 | |
| 69 | CLAMP-TUBE | 032-7003-06 | 032-7003-06 | 032-7003-06 | 032-7003-06 |
| 70 | CLIP-PIPE | 032-0688-02 | 032-0688-02 | 032-0688-02 | 032-0688-02 |
| 71 | CLIP-DIVIDER PLATE | 032-0731-00 | 032-0731-00 | 032-0731-00 | 032-0731-00 |
| 72 | HOLDER-SENSOR | 032-0592-00 | 032-0592-00 | 032-0592-00 | 032-0592-00 |
| 73 | BLOCK-TERMINAL - Black | 980-0139-08 | 980-0139-08 | 980-0139-08 | 980-0139-08 |
| 74 | BLOCK-TERMINAL - Red | 980-0139-09 | 980-0139-09 | 980-0139-09 | 980-0139-09 |

Parts List (XFAM-017Z, 020Z)

| Item | Description | XFAM-017Z-CFV-081 | XFAM-017Z-TFC-081 | XFAM-020Z-CFV-081 | XFAM-020Z-TFC-081 |
|------|--------------------------|-------------------|-------------------|-------------------|-------------------|
| 1 | BASE-PLATE | 922-0644-00 | 922-0644-00 | 922-0644-00 | 922-0644-00 |
| 2 | BOX-ELECTRICAL | 062-7053-00 | 062-7053-00 | 062-7053-00 | 062-7053-00 |
| 3 | BRACKET:EXV | 074-1207-01 | 074-1207-01 | 074-1207-01 | 074-1207-01 |
| 4 | BRACKET:STABILIZER TOP | 074-1205-00 | 074-1205-00 | 074-1205-00 | 074-1205-00 |
| 5 | BRACKET-CONTROL MTG | 074-1424-00 | 074-1424-00 | 074-1424-00 | 074-1424-00 |
| 6 | BRACKET-COVER RIGHT | 074-7284-00 | 074-7284-00 | 074-7284-00 | 074-7284-00 |
| 9 | COVER-ELECTRICAL BOX | 905-7230-00 | 905-7230-00 | 905-7230-00 | 905-7230-00 |
| 10 | COVER-HANDLE | 905-7193-00 | 905-7193-00 | 905-7193-00 | 905-7193-00 |
| 11 | COVER-RIGHT | 905-1331-00 | 905-1331-00 | 905-1331-00 | 905-1331-00 |
| 12 | HAND-WIDE GRIP | 905-1280-00 | 905-1280-00 | 905-1280-00 | 905-1280-00 |
| 13 | COVER-TOP | 905-1273-00 | 905-1273-00 | 905-1273-00 | 905-1273-00 |
| 14 | DOOR ASSEMBLY | 505-7099-00 | 505-7099-00 | 505-7099-00 | 505-7099-00 |
| 15 | GUARD-COND COIL | 924-0263-00 | 924-0263-00 | 924-0263-00 | 924-0263-00 |
| 16 | GUARD-FAN | 924-0264-00 | 924-0264-00 | 924-0264-00 | 924-0264-00 |
| 17 | HAND-GRIP | 905-7193-01 | 905-7193-01 | 905-7193-01 | 905-7193-01 |
| 18 | PLATE-DIVIDER | 903-1487-00 | 903-1487-00 | 903-1487-00 | 903-1487-00 |
| 19 | PLATE-FRONT LEFT | 905-7215-00 | 905-7215-00 | 905-7215-00 | 905-7215-00 |
| 20 | VALVE-PLATE | 903-1220-00 | 903-1220-00 | 903-1220-00 | 903-1220-00 |
| 21 | BLADE | 983-6931-00 | 983-6931-00 | 983-6931-00 | 983-6931-00 |
| 22 | CONDENSER | 066-0389-00 | 066-0389-00 | 066-0389-00 | 066-0389-00 |
| 24 | FILTER-DRIER | 913-7000-31 | 913-7000-31 | 913-7000-31 | 913-7000-31 |
| 26 | HEATER-RECEIVER | 918-0100-00 | 918-0100-00 | 918-0100-00 | 918-0100-00 |
| 27 | HEATER-CRANKCASE | 918-0052-05 | 918-0052-05 | 918-0052-05 | 918-0052-05 |
| 28 | INDICATOR-MOISTURE | 970-7003-06 | 970-7003-06 | 970-7003-06 | 970-7003-06 |
| 29 | RECEIVER ASSEMBLY | 577-0542-00 | 577-0542-00 | 577-0542-00 | 577-0542-00 |
| 32 | Valve - Pressure Relief | 910-0730-00 | 910-0730-00 | 910-0730-00 | 910-0730-00 |
| 33 | VALVE-ACCESS | 910-7062-00 | 910-7062-00 | 910-7062-00 | 910-7062-00 |
| 34 | VALVE-CHECK | 910-7003-01 | 910-7003-01 | 910-7003-01 | 910-7003-01 |
| 36 | VALVE-EXV | 910-0104-00 | 910-0104-00 | 910-0104-00 | 910-0104-00 |
| 38 | VALVE-SERVICE (Receiver) | 910-0142-02 | 910-0142-02 | 910-0142-02 | 910-0142-02 |
| 39 | VALVE-SERVICE (Liquid) | 910-7009-01 | 910-7009-01 | 910-7009-01 | 910-7009-01 |
| 40 | VALVE-SERVICE (Suction) | 910-0180-00 | 910-0180-00 | 910-0180-00 | 910-0180-00 |
| 41 | WELD COMP | ZS11KAE-PFV-818 | ZS11KAE-TF5-818 | ZS13KAE-PFV-818 | ZS13KAE-TF5-818 |
| 42 | BREAKER-CURCUIT | 971-7018-00 | 971-7018-00 | 971-7018-00 | 971-7018-00 |
| 46 | CABLE-AMBIENT SENSOR | 929-0304-00 | 929-0304-00 | 929-0304-00 | 929-0304-00 |
| 47 | CABLE-COND TEMP SENSOR | 929-0304-00 | 929-0304-00 | 929-0304-00 | 929-0304-00 |
| 48 | CABLE-DISCH TEMP SENSOR | 929-0304-00 | 929-0304-00 | 929-0304-00 | 929-0304-00 |
| 49 | CABLE-TRANSDUCER | 529-0114-08 | 529-0114-08 | 529-0114-08 | 529-0114-08 |
| 50 | CABLE-WIRE HARNESS | 529-0222-01 | 529-0222-01 | 529-0222-01 | 529-0222-01 |
| 51 | CAPACITOR-FAN | 914-0083-00 | 914-0083-00 | 914-0083-00 | 914-0083-00 |
| 52 | CAPACITOR-RUNNING | 914-0037-10 | | 914-0037-11 | |
| 53 | CAPACITOR-START | 914-0036-03 | | 914-0036-03 | |
| 54 | COIL-EXV | 923-0068-00 | 923-0068-00 | 923-0068-00 | 923-0068-00 |
| 55 | CONTACTOR | 912-1401-04 | 912-3040-02 | 912-1401-04 | 912-3040-02 |
| 56 | CONTROLLER-ELECT. UNIT | 943-0214-00 | 943-0214-00 | 943-0214-00 | 943-0214-00 |
| 57 | CONTROL-PRESSURE | 985-7031-06 | 985-7031-06 | 985-7031-06 | 985-7031-06 |
| 58 | MOTOR-FAN | 050-0316-01 | 050-0316-01 | 050-0316-01 | 050-0316-01 |
| 59 | POWER CABLE-MOLDED PLUG | 529-0060-04 | 529-0060-04 | 529-0060-04 | 529-0060-04 |
| 60 | RELAY-DEFROST | 940-0181-00 | 940-0181-00 | 940-0181-00 | 940-0181-00 |
| 61 | RELAY-POTENTIAL | 940-0001-79 | | 940-0001-79 | |
| 62 | TERMINAL BLOCK ASSEMBLY | 980-0086-00 | 980-0086-01 | 980-0086-00 | 980-0086-01 |
| 63 | TRANSDUCER - PRESSURE | 039-0026-06 | 039-0026-06 | 039-0026-06 | 039-0026-06 |
| 64 | TRANSFORMER CONTROL | 037-0038-01 | 037-0038-01 | 037-0038-01 | 037-0038-01 |
| 65 | CLAMP-CAPACITOR (Fan) | 032-0743-00 | 032-0743-00 | 032-0743-00 | 032-0743-00 |
| 66 | CLAMP-CAPACITOR (Run) | 032-0359-00 | | 032-0359-00 | |
| 67 | CLAMP-CAPACITOR (Start) | 032-0359-01 | | 032-0359-01 | |
| 69 | CLAMP-TUBE | 032-7003-06 | 032-7003-06 | 032-7003-06 | 032-7003-06 |
| 70 | CLIP-PIPE | 032-0688-02 | 032-0688-02 | 032-0688-02 | 032-0688-02 |
| 71 | CLIP-DIVIDER PLATE | 032-0731-00 | 032-0731-00 | 032-0731-00 | 032-0731-00 |
| 72 | HOLDER-SENSOR | 032-0592-00 | 032-0592-00 | 032-0592-00 | 032-0592-00 |
| 73 | BLOCK-TERMINAL - Black | 980-0139-08 | 980-0139-08 | 980-0139-08 | 980-0139-08 |
| 74 | BLOCK-TERMINAL - Red | 980-0139-09 | 980-0139-09 | 980-0139-09 | 980-0139-09 |

Parts List (XFAM-022Z, 025Z)

| Item | Description | XFAM-022Z-CFV-081 | XFAM-022Z-TFC-081 | XFAM-025Z-CFV-081 | XFAM-025Z-TFC-081 |
|------|--------------------------|-------------------|-------------------|-------------------|-------------------|
| 1 | BASE-PLATE | 922-0644-00 | 922-0644-00 | 922-0644-00 | 922-0644-00 |
| 2 | BOX-ELECTRICAL | 062-7053-00 | 062-7053-00 | 062-7053-00 | 062-7053-00 |
| 3 | BRACKET:EXV | 074-1207-01 | 074-1207-01 | 074-1207-01 | 074-1207-01 |
| 4 | BRACKET:STABILIZER TOP | 074-1205-00 | 074-1205-00 | 074-1205-00 | 074-1205-00 |
| 5 | BRACKET-CONTROL MTG | 074-1424-00 | 074-1424-00 | 074-1424-00 | 074-1424-00 |
| 6 | BRACKET-COVER RIGHT | 074-7284-00 | 074-7284-00 | 074-7284-00 | 074-7284-00 |
| 9 | COVER-ELECTRICAL BOX | 905-7230-00 | 905-7230-00 | 905-7230-00 | 905-7230-00 |
| 10 | COVER-HANDLE | 905-7193-00 | 905-7193-00 | 905-7193-00 | 905-7193-00 |
| 11 | COVER-RIGHT | 905-1331-00 | 905-1331-00 | 905-1331-00 | 905-1331-00 |
| 12 | HAND-WIDE GRIP | 905-1280-00 | 905-1280-00 | 905-1280-00 | 905-1280-00 |
| 13 | COVER-TOP | 905-1273-00 | 905-1273-00 | 905-1273-00 | 905-1273-00 |
| 14 | DOOR ASSEMBLY | 505-7099-00 | 505-7099-00 | 505-7099-00 | 505-7099-00 |
| 15 | GUARD-COND COIL | 924-0263-00 | 924-0263-00 | 924-0263-00 | 924-0263-00 |
| 16 | GUARD-FAN | 924-0264-00 | 924-0264-00 | 924-0264-00 | 924-0264-00 |
| 17 | HAND-GRIP | 905-7193-01 | 905-7193-01 | 905-7193-01 | 905-7193-01 |
| 18 | PLATE-DIVIDER | 903-1487-00 | 903-1487-00 | 903-1487-00 | 903-1487-00 |
| 19 | PLATE-FRONT LEFT | 905-7215-00 | 905-7215-00 | 905-7215-00 | 905-7215-00 |
| 20 | VALVE-PLATE | 903-1220-00 | 903-1220-00 | 903-1220-00 | 903-1220-00 |
| 21 | BLADE | 983-6931-00 | 983-6931-00 | 983-6931-00 | 983-6931-00 |
| 22 | CONDENSER | 066-0389-00 | 066-0389-00 | 066-0389-00 | 066-0389-00 |
| 24 | FILTER-DRIER | 913-7000-31 | 913-7000-31 | 913-7000-31 | 913-7000-31 |
| 26 | HEATER-RECEIVER | 918-0100-00 | 918-0100-00 | 918-0100-00 | 918-0100-00 |
| 27 | HEATER-CRANKCASE | 918-0052-05 | 918-0052-05 | 918-0052-05 | 918-0052-05 |
| 28 | INDICATOR-MOISTURE | 970-7003-06 | 970-7003-06 | 970-7003-06 | 970-7003-06 |
| 29 | RECEIVER ASSEMBLY | 577-0542-00 | 577-0542-00 | 577-0542-00 | 577-0542-00 |
| 32 | Valve - Pressure Relief | 910-0730-00 | 910-0730-00 | 910-0730-00 | 910-0730-00 |
| 33 | VALVE-ACCESS | 910-7062-00 | 910-7062-00 | 910-7062-00 | 910-7062-00 |
| 34 | VALVE-CHECK | 910-7003-01 | 910-7003-01 | 910-7003-01 | 910-7003-01 |
| 36 | VALVE-EXV | 910-0104-00 | 910-0104-00 | 910-0104-00 | 910-0104-00 |
| 38 | VALVE-SERVICE (Receiver) | 910-0142-02 | 910-0142-02 | 910-0142-02 | 910-0142-02 |
| 39 | VALVE-SERVICE (Liquid) | 910-7009-01 | 910-7009-01 | 910-7009-01 | 910-7009-01 |
| 40 | VALVE-SERVICE (Suction) | 910-0180-00 | 910-0180-00 | 910-0180-00 | 910-0180-00 |
| 41 | WELD COMP | ZS15KAE-PFV-818 | ZS15KAE-TF5-818 | ZS19KAE-PFV-818 | ZS19KAE-TF5-818 |
| 42 | BREAKER-CIRCUIT | 971-7018-00 | 971-7018-00 | 971-7018-00 | 971-7018-00 |
| 46 | CABLE-AMBIENT SENSOR | 929-0304-00 | 929-0304-00 | 929-0304-00 | 929-0304-00 |
| 47 | CABLE-COND TEMP SENSOR | 929-0304-00 | 929-0304-00 | 929-0304-00 | 929-0304-00 |
| 48 | CABLE-DISCH TEMP SENSOR | 929-0304-00 | 929-0304-00 | 929-0304-00 | 929-0304-00 |
| 49 | CABLE-TRANSDUCER | 529-0114-08 | 529-0114-08 | 529-0114-08 | 529-0114-08 |
| 50 | CABLE-WIRE HARNESS | 529-0222-01 | 529-0222-01 | 529-0222-01 | 529-0222-01 |
| 51 | CAPACITOR-FAN | 914-0083-00 | 914-0083-00 | 914-0083-00 | 914-0083-00 |
| 52 | CAPACITOR-RUNNING | 914-0037-12 | | 914-0037-36 | |
| 53 | CAPACITOR-START | 914-0036-03 | | 914-0036-03 | |
| 54 | COIL-EXV | 923-0068-00 | 923-0068-00 | 923-0068-00 | 923-0068-00 |
| 55 | CONTACTOR | 912-1401-04 | 912-3040-02 | 912-1401-04 | 912-3040-02 |
| 56 | CONTROLLER-ELECT. UNIT | 943-0214-00 | 943-0214-00 | 943-0214-00 | 943-0214-00 |
| 57 | CONTROL-PRESSURE | 985-7031-06 | 985-7031-06 | 985-7031-06 | 985-7031-06 |
| 58 | MOTOR-FAN | 050-0316-01 | 050-0316-01 | 050-0316-01 | 050-0316-01 |
| 59 | POWER CABLE-MOLDED PLUG | 529-0060-04 | 529-0060-04 | 529-0060-04 | 529-0060-04 |
| 60 | RELAY-DEFROST | 940-0181-00 | 940-0181-00 | 940-0181-00 | 940-0181-00 |
| 61 | RELAY-POTENTIAL | 940-0001-79 | | 940-0001-79 | |
| 62 | TERMINAL BLOCK ASSEMBLY | 980-0086-00 | 980-0086-01 | 980-0086-00 | 980-0086-01 |
| 63 | TRANSDUCER - PRESSURE | 039-0026-06 | 039-0026-06 | 039-0026-06 | 039-0026-06 |
| 64 | TRANSFORMER CONTROL | 037-0038-01 | 037-0038-01 | 037-0038-01 | 037-0038-01 |
| 65 | CLAMP-CAPACITOR (Fan) | 032-0743-00 | 032-0743-00 | 032-0743-00 | 032-0743-00 |
| 66 | CLAMP-CAPACITOR (Run) | 032-0359-00 | | 032-0359-00 | |
| 67 | CLAMP-CAPACITOR (Start) | 032-0359-01 | | 032-0359-01 | |
| 69 | CLAMP-TUBE | 032-7003-06 | 032-7003-06 | 032-7003-06 | 032-7003-06 |
| 70 | CLIP-PIPE | 032-0688-02 | 032-0688-02 | 032-0688-02 | 032-0688-02 |
| 71 | CLIP-DIVIDER PLATE | 032-0731-00 | 032-0731-00 | 032-0731-00 | 032-0731-00 |
| 72 | HOLDER-SENSOR | 032-0592-00 | 032-0592-00 | 032-0592-00 | 032-0592-00 |
| 73 | BLOCK-TERMINAL - Black | 980-0139-08 | 980-0139-08 | 980-0139-08 | 980-0139-08 |
| 74 | BLOCK-TERMINAL - Red | 980-0139-09 | 980-0139-09 | 980-0139-09 | 980-0139-09 |

Parts List (XFAM-030Z, 033Z)

| Item | Description | XFAM-030Z-CFV-081 | XFAM-030Z-TFC-081 | XFAM-033Z-CFV-081 | XFAM-033Z-TFC-081 |
|------|--------------------------|-------------------|-------------------|-------------------|-------------------|
| 1 | BASE-PLATE | 922-0644-00 | 922-0644-00 | 922-0644-00 | 922-0644-00 |
| 2 | BOX-ELECTRICAL | 062-7053-00 | 062-7053-00 | 062-7053-00 | 062-7053-00 |
| 3 | BRACKET:EXV | 074-1207-01 | 074-1207-01 | 074-1207-01 | 074-1207-01 |
| 4 | BRACKET:STABILIZER TOP | 074-1205-00 | 074-1205-00 | 074-1205-00 | 074-1205-00 |
| 5 | BRACKET-CONTROL MTG | 074-1424-00 | 074-1424-00 | 074-1424-00 | 074-1424-00 |
| 6 | BRACKET-COVER RIGHT | 074-7284-00 | 074-7284-00 | 074-7284-00 | 074-7284-00 |
| 9 | COVER-ELECTRICAL BOX | 905-7230-00 | 905-7230-00 | 905-7230-00 | 905-7230-00 |
| 10 | COVER-HANDLE | 905-7193-00 | 905-7193-00 | 905-7193-00 | 905-7193-00 |
| 11 | COVER-RIGHT | 905-1331-00 | 905-1331-00 | 905-1331-00 | 905-1331-00 |
| 12 | HAND-WIDE GRIP | 905-1280-00 | 905-1280-00 | 905-1280-00 | 905-1280-00 |
| 13 | COVER-TOP | 905-1273-00 | 905-1273-00 | 905-1273-00 | 905-1273-00 |
| 14 | DOOR ASSEMBLY | 505-7099-00 | 505-7099-00 | 505-7099-00 | 505-7099-00 |
| 15 | GUARD-COND COIL | 924-0263-00 | 924-0263-00 | 924-0263-00 | 924-0263-00 |
| 16 | GUARD-FAN | 924-0264-00 | 924-0264-00 | 924-0264-00 | 924-0264-00 |
| 17 | HAND-GRIP | 905-7193-01 | 905-7193-01 | 905-7193-01 | 905-7193-01 |
| 18 | PLATE-DIVIDER | 903-1487-00 | 903-1487-00 | 903-1487-00 | 903-1487-00 |
| 19 | PLATE-FRONT LEFT | 905-7215-00 | 905-7215-00 | 905-7215-00 | 905-7215-00 |
| 20 | VALVE-PLATE | 903-1220-00 | 903-1220-00 | 903-1220-00 | 903-1220-00 |
| 21 | BLADE | 983-6931-00 | 983-6931-00 | 983-6931-00 | 983-6931-00 |
| 22 | CONDENSER | 066-0800-00 | 066-0800-00 | 066-0800-00 | 066-0800-00 |
| 24 | FILTER-DRIER | 913-7000-31 | 913-7000-31 | 913-7000-31 | 913-7000-31 |
| 26 | HEATER-RECEIVER | 918-0100-00 | 918-0100-00 | 918-0100-00 | 918-0100-00 |
| 27 | HEATER-CRANKCASE | 918-0043-00 | 918-0043-00 | 918-0043-00 | 918-0043-00 |
| 28 | INDICATOR-MOISTURE | 970-7003-06 | 970-7003-06 | 970-7003-06 | 970-7003-06 |
| 29 | RECEIVER ASSEMBLY | 577-0542-00 | 577-0542-00 | 577-0542-00 | 577-0542-00 |
| 32 | Valve - Pressure Relief | 910-0730-00 | 910-0730-00 | 910-0730-00 | 910-0730-00 |
| 33 | VALVE-ACCESS | 910-7062-00 | 910-7062-00 | 910-7062-00 | 910-7062-00 |
| 34 | VALVE-CHECK | 910-7003-01 | 910-7003-01 | 910-7003-01 | 910-7003-01 |
| 36 | VALVE-EXV | 910-0104-00 | 910-0104-00 | 910-0104-00 | 910-0104-00 |
| 38 | VALVE-SERVICE (Receiver) | 910-0142-02 | 910-0142-02 | 910-0142-02 | 910-0142-02 |
| 39 | VALVE-SERVICE (Liquid) | 910-7009-01 | 910-7009-01 | 910-7009-01 | 910-7009-01 |
| 40 | VALVE-SERVICE (Suction) | 910-0180-00 | 910-0180-00 | 910-0180-00 | 910-0180-00 |
| 41 | WELD COMP | ZS21KAE-PFV-818 | ZS21KAE-TF5-818 | ZS26KAE-PFV-818 | ZS26KAE-TF5-818 |
| 42 | BREAKER-CIRCUIT | 971-7018-00 | 971-7018-00 | 971-7018-00 | 971-7018-00 |
| 46 | CABLE-AMBIENT SENSOR | 929-0304-00 | 929-0304-00 | 929-0304-00 | 929-0304-00 |
| 47 | CABLE-COND TEMP SENSOR | 929-0304-00 | 929-0304-00 | 929-0304-00 | 929-0304-00 |
| 48 | CABLE-DISCH TEMP SENSOR | 929-0304-00 | 929-0304-00 | 929-0304-00 | 929-0304-00 |
| 49 | CABLE-TRANSDUCER | 529-0114-08 | 529-0114-08 | 529-0114-08 | 529-0114-08 |
| 50 | CABLE-WIRE HARNESS | 529-0222-01 | 529-0222-01 | 529-0222-01 | 529-0222-01 |
| 51 | CAPACITOR-FAN | 914-0083-00 | 914-0083-00 | 914-0083-00 | 914-0083-00 |
| 52 | CAPACITOR-RUNNING | 914-0037-39 | | 914-0037-39 | |
| 53 | CAPACITOR-START | 914-0036-03 | | 914-0036-03 | |
| 54 | COIL-EXV | 923-0068-00 | 923-0068-00 | 923-0068-00 | 923-0068-00 |
| 55 | CONTACTOR | 912-1401-04 | 912-3040-02 | 912-1401-04 | 912-3040-02 |
| 56 | CONTROLLER-ELECT. UNIT | 943-0214-00 | 943-0214-00 | 943-0214-00 | 943-0214-00 |
| 57 | CONTROL-PRESSURE | 985-7031-06 | 985-7031-06 | 985-7031-06 | 985-7031-06 |
| 58 | MOTOR-FAN | 050-0316-01 | 050-0316-01 | 050-0316-01 | 050-0316-01 |
| 59 | POWER CABLE-MOLDED PLUG | 529-0060-04 | 529-0060-04 | 529-0060-04 | 529-0060-04 |
| 60 | RELAY-DEFROST | 940-0181-00 | 940-0181-00 | 940-0181-00 | 940-0181-00 |
| 61 | RELAY-POTENTIAL | 940-0001-79 | | 940-0001-79 | |
| 62 | TERMINAL BLOCK ASSEMBLY | 980-0086-00 | 980-0086-01 | 980-0086-00 | 980-0086-01 |
| 63 | TRANSDUCER - PRESSURE | 039-0026-06 | 039-0026-06 | 039-0026-06 | 039-0026-06 |
| 64 | TRANSFORMER CONTROL | 037-0038-01 | 037-0038-01 | 037-0038-01 | 037-0038-01 |
| 65 | CLAMP-CAPACITOR (Fan) | 032-0743-00 | 032-0743-00 | 032-0743-00 | 032-0743-00 |
| 66 | CLAMP-CAPACITOR (Run) | 032-0359-01 | | 032-0359-01 | |
| 67 | CLAMP-CAPACITOR (Start) | 032-0359-01 | | 032-0359-01 | |
| 69 | CLAMP-TUBE | 032-7003-06 | 032-7003-06 | 032-7003-06 | 032-7003-06 |
| 70 | CLIP-PIPE | 032-0688-02 | 032-0688-02 | 032-0688-02 | 032-0688-02 |
| 71 | CLIP-DIVIDER PLATE | 032-0731-00 | 032-0731-00 | 032-0731-00 | 032-0731-00 |
| 72 | HOLDER-SENSOR | 032-0592-00 | 032-0592-00 | 032-0592-00 | 032-0592-00 |
| 73 | BLOCK-TERMINAL - Black | 980-0139-08 | 980-0139-08 | 980-0139-08 | 980-0139-08 |
| 74 | BLOCK-TERMINAL - Red | 980-0139-09 | 980-0139-09 | 980-0139-09 | 980-0139-09 |

Parts List (XFAM-037Z, 045Z)

| Item | Description | XFAM-037Z-CFV-081 | XFAM-037Z-TFC-081 | XFAM-045Z-CFV-081 | XFAM-045Z-TFC-081 |
|------|--------------------------|-------------------|-------------------|-------------------|-------------------|
| 1 | BASE-PLATE | 922-0644-00 | 922-0644-00 | 922-0644-00 | 922-0644-00 |
| 2 | BOX-ELECTRICAL | 062-7053-00 | 062-7053-00 | 062-7053-00 | 062-7053-00 |
| 3 | BRACKET:EXV | 074-1207-01 | 074-1207-01 | 074-1207-01 | 074-1207-01 |
| 4 | BRACKET:STABILIZER TOP | 074-1205-00 | 074-1205-00 | 074-1205-00 | 074-1205-00 |
| 5 | BRACKET-CONTROL MTG | 074-1424-00 | 074-1424-00 | 074-1425-00 | 074-1425-00 |
| 6 | BRACKET-COVER RIGHT | 074-7284-00 | 074-7284-00 | 074-7284-00 | 074-7284-00 |
| 9 | COVER-ELECTRICAL BOX | 905-7230-00 | 905-7230-00 | 905-7230-00 | 905-7230-00 |
| 10 | COVER-HANDLE | 905-7193-00 | 905-7193-00 | 905-7193-00 | 905-7193-00 |
| 11 | COVER-RIGHT | 905-1331-00 | 905-1331-00 | 905-1332-00 | 905-1332-00 |
| 12 | HAND-WIDE GRIP | 905-1280-00 | 905-1280-00 | 905-1280-00 | 905-1280-00 |
| 13 | COVER-TOP | 905-1273-00 | 905-1273-00 | 905-1273-00 | 905-1273-00 |
| 14 | DOOR ASSEMBLY | 505-7099-00 | 505-7099-00 | 505-7098-00 | 505-7098-00 |
| 15 | GUARD-COND COIL | 924-0263-00 | 924-0263-00 | 924-0262-00 | 924-0262-00 |
| 16 | GUARD-FAN | 924-0264-00 | 924-0264-00 | 924-0264-00 | 924-0264-00 |
| 17 | HAND-GRIP | 905-7193-01 | 905-7193-01 | 905-7193-01 | 905-7193-01 |
| 18 | PLATE-DIVIDER | 903-1487-00 | 903-1487-00 | 903-1576-00 | 903-1576-00 |
| 19 | PLATE-FRONT LEFT | 905-7215-00 | 905-7215-00 | 905-7214-00 | 905-7214-00 |
| 20 | VALVE-PLATE | 903-1220-00 | 903-1220-00 | 903-1220-00 | 903-1220-00 |
| 21 | BLADE | 983-6931-00 | 983-6931-00 | 983-6931-00 | 983-6931-00 |
| 22 | CONDENSER | 066-0800-00 | 066-0800-00 | 066-0388-00 | 066-0388-00 |
| 24 | FILTER-DRIER | 913-7000-31 | 913-7000-31 | 913-7000-31 | 913-7000-31 |
| 26 | HEATER-RECEIVER | 918-0100-00 | 918-0100-00 | 918-0100-00 | 918-0100-00 |
| 27 | HEATER-CRANKCASE | 918-0043-00 | 918-0043-00 | 918-0043-00 | 918-0043-00 |
| 28 | INDICATOR-MOISTURE | 970-7003-06 | 970-7003-06 | 970-7003-06 | 970-7003-06 |
| 29 | RECEIVER ASSEMBLY | 577-0542-00 | 577-0542-00 | 577-0542-01 | 577-0542-01 |
| 32 | Valve - Pressure Relief | 910-0730-00 | 910-0730-00 | 910-0730-00 | 910-0730-00 |
| 33 | VALVE-ACCESS | 910-7062-00 | 910-7062-00 | 910-7062-00 | 910-7062-00 |
| 34 | VALVE-CHECK | 910-7003-01 | 910-7003-01 | 910-7003-01 | 910-7003-01 |
| 36 | VALVE-EXV | 910-0104-00 | 910-0104-00 | 910-0104-00 | 910-0104-00 |
| 38 | VALVE-SERVICE (Receiver) | 910-0142-02 | 910-0142-02 | 910-0142-02 | 910-0142-02 |
| 39 | VALVE-SERVICE (Liquid) | 910-7009-01 | 910-7009-01 | 910-7009-01 | 910-7009-01 |
| 40 | VALVE-SERVICE (Suction) | 910-0180-00 | 910-0180-00 | 910-0180-00 | 910-0180-00 |
| 41 | WELD COMP | ZS29KAE-PFV-818 | ZS29KAE-TF5-818 | ZS33KAE-PFV-818 | ZS33KAE-TF5-818 |
| 42 | BREAKER-CIRCUIT | 971-7018-00 | 971-7018-00 | 971-7018-00 | 971-7018-00 |
| 46 | CABLE-AMBIENT SENSOR | 929-0304-00 | 929-0304-00 | 929-0304-00 | 929-0304-00 |
| 47 | CABLE-COND TEMP SENSOR | 929-0304-00 | 929-0304-00 | 929-0304-00 | 929-0304-00 |
| 48 | CABLE-DISCH TEMP SENSOR | 929-0304-00 | 929-0304-00 | 929-0304-00 | 929-0304-00 |
| 49 | CABLE-TRANSDUCER | 529-0114-08 | 529-0114-08 | 529-0114-08 | 529-0114-08 |
| 50 | CABLE-WIRE HARNESS | 529-0222-01 | 529-0222-01 | 529-0222-02 | 529-0222-02 |
| 51 | CAPACITOR-FAN | 914-0083-00 | 914-0083-00 | 914-0083-00 | 914-0083-00 |
| 52 | CAPACITOR-RUNNING | 914-0037-22 | | 914-0037-38 | |
| 53 | CAPACITOR-START | 914-0036-03 | | 914-0036-03 | |
| 54 | COIL-EXV | 923-0068-00 | 923-0068-00 | 923-0068-00 | 923-0068-00 |
| 55 | CONTACTOR | 912-1401-04 | 912-3040-02 | 912-1401-04 | 912-3040-02 |
| 56 | CONTROLLER-ELECT. UNIT | 943-0214-00 | 943-0214-00 | 943-0214-00 | 943-0214-00 |
| 57 | CONTROL-PRESSURE | 985-7031-06 | 985-7031-06 | 985-7031-06 | 985-7031-06 |
| 58 | MOTOR-FAN | 050-0316-01 | 050-0316-01 | 050-0316-01 | 050-0316-01 |
| 59 | POWER CABLE-MOLDED PLUG | 529-0060-04 | 529-0060-04 | 529-0060-25 | 529-0060-25 |
| 60 | RELAY-DEFROST | 940-0181-00 | 940-0181-00 | 940-0181-00 | 940-0181-00 |
| 61 | RELAY-POTENTIAL | 940-0001-79 | | 940-0001-79 | |
| 62 | TERMINAL BLOCK ASSEMBLY | 980-0086-00 | 980-0086-01 | 980-0086-00 | 980-0086-01 |
| 63 | TRANSDUCER - PRESSURE | 039-0026-06 | 039-0026-06 | 039-0026-06 | 039-0026-06 |
| 64 | TRANSFORMER CONTROL | 037-0038-01 | 037-0038-01 | 037-0038-01 | 037-0038-01 |
| 65 | CLAMP-CAPACITOR (Fan) | 032-0743-00 | 032-0743-00 | 032-0743-00 | 032-0743-00 |
| 66 | CLAMP-CAPACITOR (Run) | 032-0359-01 | | 032-0359-04 | |
| 67 | CLAMP-CAPACITOR (Start) | 032-0359-01 | | 032-0359-04 | |
| 69 | CLAMP-TUBE | 032-7003-06 | 032-7003-06 | 032-7003-06 | 032-7003-06 |
| 70 | CLIP-PIPE | 032-0688-02 | 032-0688-02 | 032-0688-02 | 032-0688-02 |
| 71 | CLIP-DIVIDER PLATE | 032-0731-00 | 032-0731-00 | 032-0731-00 | 032-0731-00 |
| 72 | HOLDER-SENSOR | 032-0592-00 | 032-0592-00 | 032-0592-00 | 032-0592-00 |
| 73 | BLOCK-TERMINAL - Black | 980-0139-08 | 980-0139-08 | 980-0139-08 | 980-0139-08 |
| 74 | BLOCK-TERMINAL - Red | 980-0139-09 | 980-0139-09 | 980-0139-09 | 980-0139-09 |

Parts List (XFAM-050Z, 060Z)

| Item | Description | XFAM-050Z-CFV-081 | XFAM-050Z-TFC-081 | XFAM-060Z-TFC-081 |
|------|--------------------------|-------------------|-------------------|-------------------|
| 1 | BASE-PLATE | 922-0644-00 | 922-0644-00 | 922-0644-00 |
| 2 | BOX-ELECTRICAL | 062-7053-00 | 062-7053-00 | 062-7053-00 |
| 3 | BRACKET:EXV | 074-1207-01 | 074-1207-01 | 074-1207-01 |
| 4 | BRACKET:STABILIZER TOP | 074-1205-00 | 074-1205-00 | 074-1205-00 |
| 5 | BRACKET-CONTROL MTG | 074-1425-00 | 074-1425-00 | 074-1425-00 |
| 6 | BRACKET-COVER RIGHT | 074-7284-00 | 074-7284-00 | 074-7284-00 |
| 9 | COVER-ELECTRICAL BOX | 905-7230-00 | 905-7230-00 | 905-7230-00 |
| 10 | COVER-HANDLE | 905-7193-00 | 905-7193-00 | 905-7193-00 |
| 11 | COVER-RIGHT | 905-1332-00 | 905-1332-00 | 905-1332-00 |
| 12 | HAND-WIDE GRIP | 905-1280-00 | 905-1280-00 | 905-1280-00 |
| 13 | COVER-TOP | 905-1273-00 | 905-1273-00 | 905-1273-00 |
| 14 | DOOR ASSEMBLY | 505-7098-00 | 505-7098-00 | 505-7098-00 |
| 15 | GUARD-COND COIL | 924-0262-00 | 924-0262-00 | 924-0262-00 |
| 16 | GUARD-FAN | 924-0264-00 | 924-0264-00 | 924-0264-00 |
| 17 | HAND-GRIP | 905-7193-01 | 905-7193-01 | 905-7193-01 |
| 18 | PLATE-DIVIDER | 903-1576-00 | 903-1576-00 | 903-1576-00 |
| 19 | PLATE-FRONT LEFT | 905-7214-00 | 905-7214-00 | 905-7214-00 |
| 20 | VALVE-PLATE | 903-1220-00 | 903-1220-00 | 903-1220-00 |
| 21 | BLADE | 983-6931-00 | 983-6931-00 | 983-6931-00 |
| 22 | CONDENSER | 066-0387-00 | 066-0387-00 | 066-0393-00 |
| 24 | FILTER-DRIER | 913-7000-31 | 913-7000-31 | 913-7000-31 |
| 26 | HEATER-RECEIVER | 918-0100-00 | 918-0100-00 | 918-0100-00 |
| 27 | HEATER-CRANKCASE | 918-0043-00 | 918-0043-00 | 918-0043-00 |
| 28 | INDICATOR-MOISTURE | 970-7003-06 | 970-7003-06 | 970-7003-06 |
| 29 | RECEIVER ASSEMBLY | 577-0542-01 | 577-0542-01 | 577-0542-01 |
| 32 | Valve - Pressure Relief | 910-0730-00 | 910-0730-00 | 910-0730-00 |
| 33 | VALVE-ACCESS | 910-7062-00 | 910-7062-00 | 910-7062-00 |
| 34 | VALVE-CHECK | 910-7003-01 | 910-7003-01 | 910-7003-01 |
| 36 | VALVE-EXV | 910-0104-00 | 910-0104-00 | 910-0104-00 |
| 38 | VALVE-SERVICE (Receiver) | 910-0142-02 | 910-0142-02 | 910-0142-02 |
| 39 | VALVE-SERVICE (Liquid) | 910-7009-01 | 910-7009-01 | 910-7009-01 |
| 40 | VALVE-SERVICE (Suction) | 910-0180-00 | 910-0180-00 | 910-0180-00 |
| 41 | WELD COMP | ZF15K4E-PFV-931 | ZF15K4E-TF5-931 | ZF18K4E-TF5-931 |
| 42 | BREAKER-CIRCUIT | 971-7018-00 | 971-7018-00 | 971-7018-00 |
| 46 | CABLE-AMBIENT SENSOR | 929-0304-00 | 929-0304-00 | 929-0304-00 |
| 47 | CABLE-COND TEMP SENSOR | 929-0304-00 | 929-0304-00 | 929-0304-00 |
| 48 | CABLE-DISCH TEMP SENSOR | 929-0304-00 | 929-0304-00 | 929-0304-00 |
| 49 | CABLE-TRANSDUCER | 529-0114-08 | 529-0114-08 | 529-0114-08 |
| 50 | CABLE-WIRE HARNESS | 529-0222-02 | 529-0222-02 | 529-0222-02 |
| 51 | CAPACITOR-FAN | 914-0083-00 | 914-0083-00 | 914-0083-00 |
| 52 | CAPACITOR-RUNNING | 914-0037-38 | | |
| 53 | CAPACITOR-START | 914-0006-10 | | |
| 54 | COIL-EXV | 923-0068-00 | 923-0068-00 | 923-0068-00 |
| 55 | CONTACTOR | 912-1401-04 | 912-3040-02 | 912-3040-02 |
| 56 | CONTROLLER-ELECT. UNIT | 943-0214-00 | 943-0214-00 | 943-0214-00 |
| 57 | CONTROL-PRESSURE | 985-7031-06 | 985-7031-06 | 985-7031-06 |
| 58 | MOTOR-FAN | 050-0316-01 | 050-0316-01 | 050-0316-01 |
| 59 | POWER CABLE-MOLDED PLUG | | | |
| 60 | RELAY-DEFROST | 940-0181-00 | 940-0181-00 | 940-0181-00 |
| 61 | RELAY-POTENTIAL | 940-0001-79 | | |
| 62 | TERMINAL BLOCK ASSEMBLY | 980-0086-00 | 980-0086-01 | 980-0086-01 |
| 63 | TRANSDUCER - PRESSURE | 039-0026-06 | 039-0026-06 | 039-0026-06 |
| 64 | TRANSFORMER CONTROL | 037-0038-01 | 037-0038-01 | 037-0038-01 |
| 65 | CLAMP-CAPACITOR (Fan) | 032-0743-00 | 032-0743-00 | 032-0743-00 |
| 66 | CLAMP-CAPACITOR (Run) | 032-0359-02 | | |
| 67 | CLAMP-CAPACITOR (Start) | 032-0359-04 | | |
| 69 | CLAMP-TUBE | 032-7003-06 | 032-7003-06 | 032-7003-06 |
| 70 | CLIP-PIPE | 032-0688-02 | 032-0688-02 | 032-0688-02 |
| 71 | CLIP-DIVIDER PLATE | 032-0731-00 | 032-0731-00 | 032-0731-00 |
| 72 | HOLDER-SENSOR | 032-0592-00 | 032-0592-00 | 032-0592-00 |
| 73 | BLOCK-TERMINAL - Black | 980-0139-08 | 980-0139-08 | 980-0139-08 |
| 74 | BLOCK-TERMINAL - Red | 980-0139-09 | 980-0139-09 | 980-0139-09 |

Parts List (XFAP-015Z, 017Z)

| Item | Description | XFAP-015Z-CFV-081 | XFAP-015Z-TFC-081 | XFAP-017Z-CFV-081 | XFAP-017Z-TFC-081 |
|------|--------------------------|-------------------|-------------------|-------------------|-------------------|
| 1 | BASE-PLATE | 922-0644-00 | 922-0644-00 | 922-0644-00 | 922-0644-00 |
| 2 | BOX-ELECTRICAL | 062-7053-00 | 062-7053-00 | 062-7053-00 | 062-7053-00 |
| 3 | BRACKET:EXV | 074-1207-01 | 074-1207-01 | 074-1207-01 | 074-1207-01 |
| 4 | BRACKET:STABILIZER TOP | 074-1205-00 | 074-1205-00 | 074-1205-00 | 074-1205-00 |
| 5 | BRACKET-CONTROL MTG | 074-1424-00 | 074-1424-00 | 074-1424-00 | 074-1424-00 |
| 6 | BRACKET-COVER RIGHT | 074-7284-00 | 074-7284-00 | 074-7284-00 | 074-7284-00 |
| 8 | BRACKET-MOUNTING | 074-7282-00 | 074-7282-00 | 074-7282-00 | 074-7282-00 |
| 9 | COVER-ELECTRICAL BOX | 905-7230-00 | 905-7230-00 | 905-7230-00 | 905-7230-00 |
| 10 | COVER-HANDLE | 905-7193-00 | 905-7193-00 | 905-7193-00 | 905-7193-00 |
| 11 | COVER-RIGHT | 905-1331-00 | 905-1331-00 | 905-1331-00 | 905-1331-00 |
| 12 | HAND-WIDE GRIP | 905-1280-00 | 905-1280-00 | 905-1280-00 | 905-1280-00 |
| 13 | COVER-TOP | 905-1273-00 | 905-1273-00 | 905-1273-00 | 905-1273-00 |
| 14 | DOOR ASSEMBLY | 505-7099-00 | 505-7099-00 | 505-7099-00 | 505-7099-00 |
| 15 | GUARD-COND COIL | 924-0263-00 | 924-0263-00 | 924-0263-00 | 924-0263-00 |
| 16 | GUARD-FAN | 924-0264-00 | 924-0264-00 | 924-0264-00 | 924-0264-00 |
| 17 | HAND-GRIP | 905-7193-01 | 905-7193-01 | 905-7193-01 | 905-7193-01 |
| 18 | PLATE-DIVIDER | 903-1487-00 | 903-1487-00 | 903-1487-00 | 903-1487-00 |
| 19 | PLATE-FRONT LEFT | 905-7215-00 | 905-7215-00 | 905-7215-00 | 905-7215-00 |
| 20 | VALVE-PLATE | 903-1220-00 | 903-1220-00 | 903-1220-00 | 903-1220-00 |
| 21 | BLADE | 983-6931-00 | 983-6931-00 | 983-6931-00 | 983-6931-00 |
| 22 | CONDENSER | 066-0389-00 | 066-0389-00 | 066-0389-00 | 066-0389-00 |
| 24 | FILTER-DRIER | 913-7000-31 | 913-7000-31 | 913-7000-31 | 913-7000-31 |
| 26 | HEATER-RECEIVER | 918-0100-00 | 918-0100-00 | 918-0100-00 | 918-0100-00 |
| 27 | HEATER-CRANKCASE | 918-0052-05 | 918-0052-05 | 918-0052-05 | 918-0052-05 |
| 28 | INDICATOR-MOISTURE | 970-7003-06 | 970-7003-06 | 970-7003-06 | 970-7003-06 |
| 29 | RECEIVER ASSEMBLY | 577-0542-00 | 577-0542-00 | 577-0542-00 | 577-0542-00 |
| 30 | TANK-ACCUMULATOR | 977-0037-01 | 977-0037-01 | 977-0037-01 | 977-0037-01 |
| 32 | Valve - Pressure Relief | 910-0730-00 | 910-0730-00 | 910-0730-00 | 910-0730-00 |
| 33 | VALVE-ACCESS | 910-7062-00 | 910-7062-00 | 910-7062-00 | 910-7062-00 |
| 34 | VALVE-CHECK | 910-7003-01 | 910-7003-01 | 910-7003-01 | 910-7003-01 |
| 36 | VALVE-EXV | 910-0104-00 | 910-0104-00 | 910-0104-00 | 910-0104-00 |
| 38 | VALVE-SERVICE (Receiver) | 910-0142-02 | 910-0142-02 | 910-0142-02 | 910-0142-02 |
| 39 | VALVE-SERVICE (Liquid) | 910-7009-01 | 910-7009-01 | 910-7009-01 | 910-7009-01 |
| 40 | VALVE-SERVICE (Suction) | 910-0180-00 | 910-0180-00 | 910-0180-00 | 910-0180-00 |
| 41 | WELD COMP | ZS09KAE-PFV-818 | ZS09KAE-TF5-818 | ZS11KAE-PFV-818 | ZS11KAE-TF5-818 |
| 42 | BREAKER-CIRCUIT | 971-7018-00 | 971-7018-00 | 971-7018-00 | 971-7018-00 |
| 46 | CABLE-AMBIENT SENSOR | 929-0304-00 | 929-0304-00 | 929-0304-00 | 929-0304-00 |
| 47 | CABLE-COND TEMP SENSOR | 929-0304-00 | 929-0304-00 | 929-0304-00 | 929-0304-00 |
| 48 | CABLE-DISCH TEMP SENSOR | 929-0304-00 | 929-0304-00 | 929-0304-00 | 929-0304-00 |
| 49 | CABLE-TRANSDUCER | 529-0114-08 | 529-0114-08 | 529-0114-08 | 529-0114-08 |
| 50 | CABLE-WIRE HARNESS | 529-0222-01 | 529-0222-01 | 529-0222-01 | 529-0222-01 |
| 51 | CAPACITOR-FAN | 914-0083-00 | 914-0083-00 | 914-0083-00 | 914-0083-00 |
| 52 | CAPACITOR-RUNNING | 914-0037-10 | | 914-0037-10 | |
| 53 | CAPACITOR-START | 914-0036-03 | | 914-0036-03 | |
| 54 | COIL-EXV | 923-0068-00 | 923-0068-00 | 923-0068-00 | 923-0068-00 |
| 55 | CONTACTOR | 912-1401-04 | 912-3040-02 | 912-1401-04 | 912-3040-02 |
| 56 | CONTROLLER-ELECT. UNIT | 943-0214-00 | 943-0214-00 | 943-0214-00 | 943-0214-00 |
| 57 | CONTROL-PRESSURE | 985-7031-06 | 985-7031-06 | 985-7031-06 | 985-7031-06 |
| 58 | MOTOR-FAN | 050-0316-01 | 050-0316-01 | 050-0316-01 | 050-0316-01 |
| 59 | POWER CABLE-MOLDED PLUG | 529-0060-04 | 529-0060-04 | 529-0060-04 | 529-0060-04 |
| 60 | RELAY-DEFROST | 940-0181-00 | 940-0181-00 | 940-0181-00 | 940-0181-00 |
| 61 | RELAY-POTENTIAL | 940-0001-79 | | 940-0001-79 | |
| 62 | TERMINAL BLOCK ASSEMBLY | 980-0086-00 | 980-0086-01 | 980-0086-00 | 980-0086-01 |
| 63 | TRANSDUCER - PRESSURE | 039-0026-06 | 039-0026-06 | 039-0026-06 | 039-0026-06 |
| 64 | TRANSFORMER CONTROL | 037-0038-01 | 037-0038-01 | 037-0038-01 | 037-0038-01 |
| 65 | CLAMP-CAPACITOR (Fan) | 032-0743-00 | 032-0743-00 | 032-0743-00 | 032-0743-00 |
| 66 | CLAMP-CAPACITOR (Run) | 032-0359-00 | | 032-0359-00 | |
| 67 | CLAMP-CAPACITOR (Start) | 032-0359-01 | | 032-0359-01 | |
| 69 | CLAMP-TUBE | 032-7003-06 | 032-7003-06 | 032-7003-06 | 032-7003-06 |
| 70 | CLIP-PIPE | 032-0688-02 | 032-0688-02 | 032-0688-02 | 032-0688-02 |
| 71 | CLIP-DIVIDER PLATE | 032-0731-00 | 032-0731-00 | 032-0731-00 | 032-0731-00 |
| 72 | HOLDER-SENSOR | 032-0592-00 | 032-0592-00 | 032-0592-00 | 032-0592-00 |
| 73 | BLOCK-TERMINAL - Black | 980-0139-08 | 980-0139-08 | 980-0139-08 | 980-0139-08 |
| 74 | BLOCK-TERMINAL - Red | 980-0139-09 | 980-0139-09 | 980-0139-09 | 980-0139-09 |

Parts List (XFAP-022Z, 030Z)

| Item | Description | XFAP-022Z-CFV-081 | XFAP-022Z-TFC-081 | XFAP-030Z-CFV-081 | XFAP-030Z-TFC-081 |
|------|--------------------------|-------------------|-------------------|-------------------|-------------------|
| 1 | BASE-PLATE | 922-0644-00 | 922-0644-00 | 922-0644-00 | 922-0644-00 |
| 2 | BOX-ELECTRICAL | 062-7053-00 | 062-7053-00 | 062-7053-00 | 062-7053-00 |
| 3 | BRACKET:EXV | 074-1207-01 | 074-1207-01 | 074-1207-01 | 074-1207-01 |
| 4 | BRACKET:STABILIZER TOP | 074-1205-00 | 074-1205-00 | 074-1205-00 | 074-1205-00 |
| 5 | BRACKET-CONTROL MTG | 074-1424-00 | 074-1424-00 | 074-1424-00 | 074-1424-00 |
| 6 | BRACKET-COVER RIGHT | 074-7284-00 | 074-7284-00 | 074-7284-00 | 074-7284-00 |
| 8 | BRACKET-MOUNTING | 074-7282-00 | 074-7282-00 | 074-7282-00 | 074-7282-00 |
| 9 | COVER-ELECTRICAL BOX | 905-7230-00 | 905-7230-00 | 905-7230-00 | 905-7230-00 |
| 10 | COVER-HANDLE | 905-7193-00 | 905-7193-00 | 905-7193-00 | 905-7193-00 |
| 11 | COVER-RIGHT | 905-1331-00 | 905-1331-00 | 905-1331-00 | 905-1331-00 |
| 12 | HAND-WIDE GRIP | 905-1280-00 | 905-1280-00 | 905-1280-00 | 905-1280-00 |
| 13 | COVER-TOP | 905-1273-00 | 905-1273-00 | 905-1273-00 | 905-1273-00 |
| 14 | DOOR ASSEMBLY | 505-7099-00 | 505-7099-00 | 505-7099-00 | 505-7099-00 |
| 15 | GUARD-COND COIL | 924-0263-00 | 924-0263-00 | 924-0263-00 | 924-0263-00 |
| 16 | GUARD-FAN | 924-0264-00 | 924-0264-00 | 924-0264-00 | 924-0264-00 |
| 17 | HAND-GRIP | 905-7193-01 | 905-7193-01 | 905-7193-01 | 905-7193-01 |
| 18 | PLATE-DIVIDER | 903-1487-00 | 903-1487-00 | 903-1487-00 | 903-1487-00 |
| 19 | PLATE-FRONT LEFT | 905-7215-00 | 905-7215-00 | 905-7215-00 | 905-7215-00 |
| 20 | VALVE-PLATE | 903-1220-00 | 903-1220-00 | 903-1220-00 | 903-1220-00 |
| 21 | BLADE | 983-6931-00 | 983-6931-00 | 983-6931-00 | 983-6931-00 |
| 22 | CONDENSER | 066-0389-00 | 066-0389-00 | 066-0800-00 | 066-0800-00 |
| 24 | FILTER-DRIER | 913-7000-31 | 913-7000-31 | 913-7000-31 | 913-7000-31 |
| 26 | HEATER-RECEIVER | 918-0100-00 | 918-0100-00 | 918-0100-00 | 918-0100-00 |
| 27 | HEATER-CRANKCASE | 918-0052-05 | 918-0052-05 | 918-0043-00 | 918-0043-00 |
| 28 | INDICATOR-MOISTURE | 970-7003-06 | 970-7003-06 | 970-7003-06 | 970-7003-06 |
| 29 | RECEIVER ASSEMBLY | 577-0542-00 | 577-0542-00 | 577-0542-00 | 577-0542-00 |
| 30 | TANK-ACCUMULATOR | 977-0037-01 | 977-0037-01 | 977-0037-01 | 977-0037-01 |
| 32 | Valve - Pressure Relief | 910-0730-00 | 910-0730-00 | 910-0730-00 | 910-0730-00 |
| 33 | VALVE-ACCESS | 910-7062-00 | 910-7062-00 | 910-7062-00 | 910-7062-00 |
| 34 | VALVE-CHECK | 910-7003-01 | 910-7003-01 | 910-7003-01 | 910-7003-01 |
| 36 | VALVE-EXV | 910-0104-00 | 910-0104-00 | 910-0104-00 | 910-0104-00 |
| 38 | VALVE-SERVICE (Receiver) | 910-0142-02 | 910-0142-02 | 910-0142-02 | 910-0142-02 |
| 39 | VALVE-SERVICE (Liquid) | 910-7009-01 | 910-7009-01 | 910-7009-01 | 910-7009-01 |
| 40 | VALVE-SERVICE (Suction) | 910-0180-00 | 910-0180-00 | 910-0180-00 | 910-0180-00 |
| 41 | WELD COMP | ZS15KAE-PFV-818 | ZS15KAE-TF5-818 | ZS21KAE-PFV-818 | ZS21KAE-TF5-818 |
| 42 | BREAKER-CURCUIT | 971-7018-00 | 971-7018-00 | 971-7018-00 | 971-7018-00 |
| 46 | CABLE-AMBIENT SENSOR | 929-0304-00 | 929-0304-00 | 929-0304-00 | 929-0304-00 |
| 47 | CABLE-COND TEMP SENSOR | 929-0304-00 | 929-0304-00 | 929-0304-00 | 929-0304-00 |
| 48 | CABLE-DISCH TEMP SENSOR | 929-0304-00 | 929-0304-00 | 929-0304-00 | 929-0304-00 |
| 49 | CABLE-TRANSDUCER | 529-0114-08 | 529-0114-08 | 529-0114-08 | 529-0114-08 |
| 50 | CABLE-WIRE HARNESS | 529-0222-01 | 529-0222-01 | 529-0222-01 | 529-0222-01 |
| 51 | CAPACITOR-FAN | 914-0083-00 | 914-0083-00 | 914-0083-00 | 914-0083-00 |
| 52 | CAPACITOR-RUNNING | 914-0037-12 | | 914-0037-39 | |
| 53 | CAPACITOR-START | 914-0036-03 | | 914-0036-03 | |
| 54 | COIL-EXV | 923-0068-00 | 923-0068-00 | 923-0068-00 | 923-0068-00 |
| 55 | CONTACTOR | 912-1401-04 | 912-3040-02 | 912-1401-04 | 912-3040-02 |
| 56 | CONTROLLER-ELECT. UNIT | 943-0214-00 | 943-0214-00 | 943-0214-00 | 943-0214-00 |
| 57 | CONTROL-PRESSURE | 985-7031-06 | 985-7031-06 | 985-7031-06 | 985-7031-06 |
| 58 | MOTOR-FAN | 050-0316-01 | 050-0316-01 | 050-0316-01 | 050-0316-01 |
| 59 | POWER CABLE-MOLDED PLUG | 529-0060-04 | 529-0060-04 | 529-0060-04 | 529-0060-04 |
| 60 | RELAY-DEFROST | 940-0181-00 | 940-0181-00 | 940-0181-00 | 940-0181-00 |
| 61 | RELAY-POTENTIAL | 940-0001-79 | | 940-0001-79 | |
| 62 | TERMINAL BLOCK ASSEMBLY | 980-0086-00 | 980-0086-01 | 980-0086-00 | 980-0086-01 |
| 63 | TRANSDUCER - PRESSURE | 039-0026-06 | 039-0026-06 | 039-0026-06 | 039-0026-06 |
| 64 | TRANSFORMER CONTROL | 037-0038-01 | 037-0038-01 | 037-0038-01 | 037-0038-01 |
| 65 | CLAMP-CAPACITOR (Fan) | 032-0743-00 | 032-0743-00 | 032-0743-00 | 032-0743-00 |
| 66 | CLAMP-CAPACITOR (Run) | 032-0359-00 | | 032-0359-01 | |
| 67 | CLAMP-CAPACITOR (Start) | 032-0359-01 | | 032-0359-01 | |
| 69 | CLAMP-TUBE | 032-7003-06 | 032-7003-06 | 032-7003-06 | 032-7003-06 |
| 70 | CLIP-PIPE | 032-0688-02 | 032-0688-02 | 032-0688-02 | 032-0688-02 |
| 71 | CLIP-DIVIDER PLATE | 032-0731-00 | 032-0731-00 | 032-0731-00 | 032-0731-00 |
| 72 | HOLDER-SENSOR | 032-0592-00 | 032-0592-00 | 032-0592-00 | 032-0592-00 |
| 73 | BLOCK-TERMINAL - Black | 980-0139-08 | 980-0139-08 | 980-0139-08 | 980-0139-08 |
| 74 | BLOCK-TERMINAL - Red | 980-0139-09 | 980-0139-09 | 980-0139-09 | 980-0139-09 |

Parts List (XFAP-045Z, 050Z)

| Item | Description | XFAP-045Z-CFV-081 | XFAP-045Z-TFC-081 | XFAP-050Z-CFV-081 | XFAP-050Z-TFC-081 |
|------|--------------------------|-------------------|-------------------|-------------------|-------------------|
| 1 | BASE-PLATE | 922-0644-00 | 922-0644-00 | 922-0644-00 | 922-0644-00 |
| 2 | BOX-ELECTRICAL | 062-7053-00 | 062-7053-00 | 062-7053-00 | 062-7053-00 |
| 3 | BRACKET:EXV | 074-1207-01 | 074-1207-01 | 074-1207-01 | 074-1207-01 |
| 4 | BRACKET:STABILIZER TOP | 074-1205-00 | 074-1205-00 | 074-1205-00 | 074-1205-00 |
| 5 | BRACKET-CONTROL MTG | 074-1425-00 | 074-1425-00 | 074-1425-00 | 074-1425-00 |
| 6 | BRACKET-COVER RIGHT | 074-7284-00 | 074-7284-00 | 074-7284-00 | 074-7284-00 |
| 8 | BRACKET-MOUNTING | 074-7282-00 | 074-7282-00 | 074-7282-00 | 074-7282-00 |
| 9 | COVER-ELECTRICAL BOX | 905-7230-00 | 905-7230-00 | 905-7230-00 | 905-7230-00 |
| 10 | COVER-HANDLE | 905-7193-00 | 905-7193-00 | 905-7193-00 | 905-7193-00 |
| 11 | COVER-RIGHT | 905-1332-00 | 905-1332-00 | 905-1332-00 | 905-1332-00 |
| 12 | HAND-WIDE GRIP | 905-1280-00 | 905-1280-00 | 905-1280-00 | 905-1280-00 |
| 13 | COVER-TOP | 905-1273-00 | 905-1273-00 | 905-1273-00 | 905-1273-00 |
| 14 | DOOR ASSEMBLY | 505-7098-00 | 505-7098-00 | 505-7098-00 | 505-7098-00 |
| 15 | GUARD-COND COIL | 924-0262-00 | 924-0262-00 | 924-0262-00 | 924-0262-00 |
| 16 | GUARD-FAN | 924-0264-00 | 924-0264-00 | 924-0264-00 | 924-0264-00 |
| 17 | HAND-GRIP | 905-7193-01 | 905-7193-01 | 905-7193-01 | 905-7193-01 |
| 18 | PLATE-DIVIDER | 903-1576-00 | 903-1576-00 | 903-1576-00 | 903-1576-00 |
| 19 | PLATE-FRONT LEFT | 905-7214-00 | 905-7214-00 | 905-7214-00 | 905-7214-00 |
| 20 | VALVE-PLATE | 903-1220-00 | 903-1220-00 | 903-1220-00 | 903-1220-00 |
| 21 | BLADE | 983-6931-00 | 983-6931-00 | 983-6931-00 | 983-6931-00 |
| 22 | CONDENSER | 066-0388-00 | 066-0388-00 | 066-0387-00 | 066-0387-00 |
| 24 | FILTER-DRIER | 913-7000-31 | 913-7000-31 | 913-7000-31 | 913-7000-31 |
| 26 | HEATER-RECEIVER | 918-0100-00 | 918-0100-00 | 918-0100-00 | 918-0100-00 |
| 27 | HEATER-CRANKCASE | 918-0043-00 | 918-0043-00 | 918-0043-00 | 918-0043-00 |
| 28 | INDICATOR-MOISTURE | 970-7003-06 | 970-7003-06 | 970-7003-06 | 970-7003-06 |
| 29 | RECEIVER ASSEMBLY | 577-0542-01 | 577-0542-01 | 577-0542-01 | 577-0542-01 |
| 30 | TANK-ACCUMULATOR | 977-0036-01 | 977-0036-01 | 977-0036-01 | 977-0036-01 |
| 32 | Valve - Pressure Relief | 910-0730-00 | 910-0730-00 | 910-0730-00 | 910-0730-00 |
| 33 | VALVE-ACCESS | 910-7062-00 | 910-7062-00 | 910-7062-00 | 910-7062-00 |
| 34 | VALVE-CHECK | 910-7003-01 | 910-7003-01 | 910-7003-01 | 910-7003-01 |
| 36 | VALVE-EXV | 910-0104-00 | 910-0104-00 | 910-0104-00 | 910-0104-00 |
| 38 | VALVE-SERVICE (Receiver) | 910-0142-02 | 910-0142-02 | 910-0142-02 | 910-0142-02 |
| 39 | VALVE-SERVICE (Liquid) | 910-7009-01 | 910-7009-01 | 910-7009-01 | 910-7009-01 |
| 40 | VALVE-SERVICE (Suction) | 910-0180-00 | 910-0180-00 | 910-0180-00 | 910-0180-00 |
| 41 | WELD COMP | ZS33KAE-PFV-818 | ZS33KAE-TF5-818 | ZF15K4E-PFV-931 | ZF15K4E-TF5-931 |
| 42 | BREAKER-CURCUIT | 971-7018-00 | 971-7018-00 | 971-7018-00 | 971-7018-00 |
| 46 | CABLE-AMBIENT SENSOR | 929-0304-00 | 929-0304-00 | 929-0304-00 | 929-0304-00 |
| 47 | CABLE-COND TEMP SENSOR | 929-0304-00 | 929-0304-00 | 929-0304-00 | 929-0304-00 |
| 48 | CABLE-DISCH TEMP SENSOR | 929-0304-00 | 929-0304-00 | 929-0304-00 | 929-0304-00 |
| 49 | CABLE-TRANSDUCER | 529-0114-08 | 529-0114-08 | 529-0114-08 | 529-0114-08 |
| 50 | CABLE-WIRE HARNESS | 529-0222-02 | 529-0222-02 | 529-0222-02 | 529-0222-02 |
| 51 | CAPACITOR-FAN | 914-0083-00 | 914-0083-00 | 914-0083-00 | 914-0083-00 |
| 52 | CAPACITOR-RUNNING | 914-0037-38 | | 914-0037-38 | |
| 53 | CAPACITOR-START | 914-0036-03 | | 914-0006-10 | |
| 54 | COIL-EXV | 923-0068-00 | 923-0068-00 | 923-0068-00 | 923-0068-00 |
| 55 | CONTACTOR | 912-1401-04 | 912-3040-02 | 912-1401-04 | 912-3040-02 |
| 56 | CONTROLLER-ELECT. UNIT | 943-0214-00 | 943-0214-00 | 943-0214-00 | 943-0214-00 |
| 57 | CONTROL-PRESSURE | 985-7031-06 | 985-7031-06 | 985-7031-06 | 985-7031-06 |
| 58 | MOTOR-FAN | 050-0316-01 | 050-0316-01 | 050-0316-01 | 050-0316-01 |
| 59 | POWER CABLE-MOLDED PLUG | 529-0060-25 | 529-0060-25 | | |
| 60 | RELAY-DEFROST | 940-0181-00 | 940-0181-00 | 940-0181-00 | 940-0181-00 |
| 61 | RELAY-POTENTIAL | 940-0001-79 | | 940-0001-79 | |
| 62 | TERMINAL BLOCK ASSEMBLY | 980-0086-00 | 980-0086-01 | 980-0086-00 | 980-0086-01 |
| 63 | TRANSDUCER - PRESSURE | 039-0026-06 | 039-0026-06 | 039-0026-06 | 039-0026-06 |
| 64 | TRANSFORMER CONTROL | 037-0038-01 | 037-0038-01 | 037-0038-01 | 037-0038-01 |
| 65 | CLAMP-CAPACITOR (Fan) | 032-0743-00 | 032-0743-00 | 032-0743-00 | 032-0743-00 |
| 66 | CLAMP-CAPACITOR (Run) | 032-0359-04 | | 032-0359-02 | |
| 67 | CLAMP-CAPACITOR (Start) | 032-0359-04 | | 032-0359-04 | |
| 69 | CLAMP-TUBE | 032-7003-06 | 032-7003-06 | 032-7003-06 | 032-7003-06 |
| 70 | CLIP-PIPE | 032-0688-02 | 032-0688-02 | 032-0688-02 | 032-0688-02 |
| 71 | CLIP-DIVIDER PLATE | 032-0731-00 | 032-0731-00 | 032-0731-00 | 032-0731-00 |
| 72 | HOLDER-SENSOR | 032-0592-00 | 032-0592-00 | 032-0592-00 | 032-0592-00 |
| 73 | BLOCK-TERMINAL - Black | 980-0139-08 | 980-0139-08 | 980-0139-08 | 980-0139-08 |
| 74 | BLOCK-TERMINAL - Red | 980-0139-09 | 980-0139-09 | 980-0139-09 | 980-0139-09 |

Parts List (XFAP-060Z)

| Item | Description | XFAP-060Z-TFC-081 |
|------|--------------------------|-------------------|
| 1 | BASE-PLATE | 922-0644-00 |
| 2 | BOX-ELECTRICAL | 062-7053-00 |
| 3 | BRACKET:EXV | 074-1207-01 |
| 4 | BRACKET:STABILIZER TOP | 074-1205-00 |
| 5 | BRACKET-CONTROL MTG | 074-1425-00 |
| 6 | BRACKET-COVER RIGHT | 074-7284-00 |
| 8 | BRACKET-MOUNTING | 074-7282-00 |
| 9 | COVER-ELECTRICAL BOX | 905-7230-00 |
| 10 | COVER-HANDLE | 905-7193-00 |
| 11 | COVER-RIGHT | 905-1332-00 |
| 12 | HAND-WIDE GRIP | 905-1280-00 |
| 13 | COVER-TOP | 905-1273-00 |
| 14 | DOOR ASSEMBLY | 505-7098-00 |
| 15 | GUARD-COND COIL | 924-0262-00 |
| 16 | GUARD-FAN | 924-0264-00 |
| 17 | HAND-GRIP | 905-7193-01 |
| 18 | PLATE-DIVIDER | 903-1576-00 |
| 19 | PLATE-FRONT LEFT | 905-7214-00 |
| 20 | VALVE-PLATE | 903-1220-00 |
| 21 | BLADE | 983-6931-00 |
| 22 | CONDENSER | 066-0393-00 |
| 24 | FILTER-DRIER | 913-7000-31 |
| 26 | HEATER-RECEIVER | 918-0100-00 |
| 27 | HEATER-CRANKCASE | 918-0043-00 |
| 28 | INDICATOR-MOISTURE | 970-7003-06 |
| 29 | RECEIVER ASSEMBLY | 577-0542-01 |
| 30 | TANK-ACCUMULATOR | 977-0036-01 |
| 32 | Valve - Pressure Relief | 910-0730-00 |
| 33 | VALVE-ACCESS | 910-7062-00 |
| 34 | VALVE-CHECK | 910-7003-01 |
| 36 | VALVE-EXV | 910-0104-00 |
| 38 | VALVE-SERVICE (Receiver) | 910-0142-02 |
| 39 | VALVE-SERVICE (Liquid) | 910-7009-01 |
| 40 | VALVE-SERVICE (Suction) | 910-0180-00 |
| 41 | WELD COMP | ZF18K4E-TF5-931 |
| 42 | BREAKER-CURCUIT | 971-7018-00 |
| 46 | CABLE-AMBIENT SENSOR | 929-0304-00 |
| 47 | CABLE-COND TEMP SENSOR | 929-0304-00 |
| 48 | CABLE-DISCH TEMP SENSOR | 929-0304-00 |
| 49 | CABLE-TRANSDUCER | 529-0114-08 |
| 50 | CABLE-WIRE HARNESS | 529-0222-02 |
| 51 | CAPACITOR-FAN | 914-0083-00 |
| 52 | CAPACITOR-RUNNING | |
| 53 | CAPACITOR-START | |
| 54 | COIL-EXV | 923-0068-00 |
| 55 | CONTACTOR | 912-3040-02 |
| 56 | CONTROLLER-ELECT. UNIT | 943-0214-00 |
| 57 | CONTROL-PRESSURE | 985-7031-06 |
| 58 | MOTOR-FAN | 050-0316-01 |
| 59 | POWER CABLE-MOLDED PLUG | |
| 60 | RELAY-DEFROST | 940-0181-00 |
| 61 | RELAY-POTENTIAL | |
| 62 | TERMINAL BLOCK ASSEMBLY | 980-0086-01 |
| 63 | TRANSDUCER - PRESSURE | 039-0026-06 |
| 64 | TRANSFORMER CONTROL | 037-0038-01 |
| 65 | CLAMP-CAPACITOR (Fan) | 032-0743-00 |
| 66 | CLAMP-CAPACITOR (Run) | |
| 67 | CLAMP-CAPACITOR (Start) | |
| 69 | CLAMP-TUBE | 032-7003-06 |
| 70 | CLIP-PIPE | 032-0688-02 |
| 71 | CLIP-DIVIDER PLATE | 032-0731-00 |
| 72 | HOLDER-SENSOR | 032-0592-00 |
| 73 | BLOCK-TERMINAL - Black | 980-0139-08 |
| 74 | BLOCK-TERMINAL - Red | 980-0139-09 |

Appendix D: Quick Setup Guide

1 Set the clock



The unit will flash *rtc* the first time power is applied or if the clock has lost its setting.

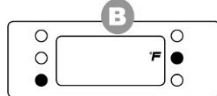

Press and hold ∇ + SET until *F* flashes.

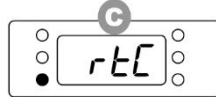

Press SET to select the *rtc* menu.



Use SET and Δ ∇ buttons to select and adjust clock parameters.

Clock Parameters

| Par. | Description | Value Range |
|------------|-------------|-------------|
| <i>Min</i> | Minute | 0-59 |
| <i>hr</i> | Hour | 0-23 |
| <i>Day</i> | Day | 1-31 |
| <i>Mon</i> | Month | 1-12 |
| <i>Yr</i> | Year | 0-99 |

2 Set pressure controls

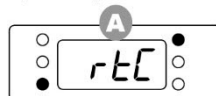

Press SET and Δ to exit the *rtc* menu. If SET and Δ are held, the control will exit program mode. Use ∇ and SET to return to program mode.



Use the Δ or ∇ buttons to find the *PAR* menu, then press SET to select.

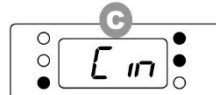

Use SET and Δ ∇ buttons to select and adjust pressure parameters.

Pressure Parameters

| Par. | Description | Value Range |
|--------------|-------------|---|
| <i>C in</i> | Cut In | 10-135 (psi) |
| <i>C out</i> | Cut Out | 0-30 (psi) |
| <i>rEF</i> | Refrigerant | 22, 134, 404, (4)07A, (4)07C, 507 (may vary by model) |

3 Set defrost parameters and schedule



From the *PAR* menu, use SET and Δ ∇ buttons to select and adjust defrost parameters.

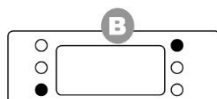

Press and hold SET and Δ to exit program mode.

Defrost Parameters

| Par. | Description | Value Range |
|------------|--------------------------|---|
| <i>idF</i> | Interval between defrost | 0-120 (hours) |
| <i>ndF</i> | Max duration | 0-255 (minutes) |
| <i>EdF</i> | Defrost mode | <i>nU</i> (off), <i>in</i> (interval), <i>rtc</i> (clock) |
| <i>ld1</i> | 1st start time | <i>nU</i> (not used), 0-23:50 |
| <i>ld2</i> | 2nd start time | |
| <i>ld3</i> | 3rd start time | |
| <i>ld4</i> | 4th start time | |
| <i>ld5</i> | 5th start time | |
| <i>ld6</i> | 6th start time | |

IMPORTANT BEFORE PROGRAMMING – DETERMINE DESIRED DEFOST MODE

1. Press and Hold SET + DOWN for 3 seconds
2. Using arrows scroll to RTC and select by pressing SET
3. Press UP or DOWN and select EdF
4. Press SET and select interval mode (*in*), real time clock mode (*rtc*), or not used (*nU*)
5. Press SET to confirm section then proceed to step 6 if (*in*) selected, or step 8 if (*rtc*) selected

Interval Mode (*in*) - Interval between defrost cycles
RTC Mode (*rtc*) - Real time clock based defrost schedule
Not Used Mode (*nU*) - Defrost not used

IF USING INTERVAL DEFOST MODE (*in*)

6. Scroll through options and select (*idF*) by pressing SET. Scroll to desired defrost interval (hours) and confirm by pressing SET.
7. Scroll through options and select (*ndF*) by pressing SET. Scroll to desired defrost duration (minutes) and confirm by pressing SET.

IF USING TIME OF DAY DEFOST MODE (*rtc*)

8. Scroll to *Ld1* and confirm by pressing SET. Set desired defrost time (0.1 = 12:10AM, 13.5 = 1:50PM) and confirm by pressing SET
9. Scroll to *Ld2-Ld6* and repeat step 8 for each desired time of day. Set all unneeded options to (*nU*)

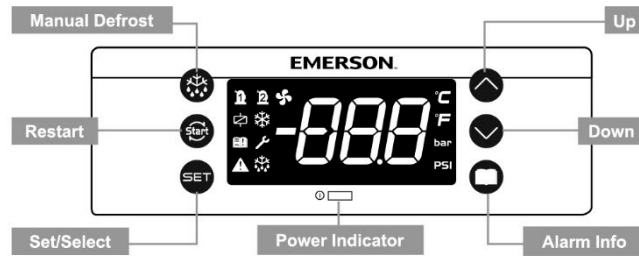

Navigation

Enter program mode* ∇ + SET 3 seconds (F flash)

Cycle through options/adjust values Δ ∇

Select function/store function SET

Exit program mode Δ + SET

*Program mode will terminate after 60 seconds of inactivity.

View Values and Set Points Values and Set Points

| |
|--|
| From main screen, press and release Δ |
| Cycle through parameters Δ ∇ |
| Select value SET |
| Go to next parameter SET |
| Exit menu Δ + SET |

*Program mode will terminate after 60 seconds of inactivity.

| Par | Description | Par | Description |
|------------|------------------|------------|-----------------------|
| <i>P1P</i> | Suction Pressure | <i>oPP</i> | EXV % |
| <i>P2t</i> | Cond. Temp. | <i>LL5</i> | NA |
| <i>P2P</i> | NA | <i>Fa0</i> | Fan Speed % |
| <i>P3t</i> | DLT | <i>d5o</i> | NA |
| <i>P4t</i> | Vapor Inlet | <i>Lt</i> | NA |
| <i>P5t</i> | Vapor Outlet | <i>Ht</i> | NA |
| <i>P6t</i> | Ambient Temp | <i>Hr</i> | RTC Menu |
| <i>P7t</i> | Liquid Line Temp | <i>Std</i> | Dynamic Fan Set Point |
| <i>SH</i> | NA | | |

| Code | Description | Code | Description |
|------|--------------------|------|---------------------------------------|
| 01 | AI1 | 27 | Over Voltage |
| 02 | AI2 | 28 | Compressor Build-in Protector Trip |
| 03 | AI3 | 29 | Power Frequency (manual) |
| 04 | AI4 | 40 | High Pressure Switch |
| 05 | AI5 | 41 | Lower Pressure Switch |
| 06 | AI6 | 43 | Low Pressure |
| 07 | AI7 | 44 | Discharge Line Temperature |
| 08 | Current Sensor 1 | 45 | High Condenser Temperature |
| 10 | Current Sensor 2 | 47 | EXV Full Open in EVI |
| 11 | Voltage Sensor 1 | 48 | Refrigerant Shortage Error in EVI |
| 12 | Voltage Sensor 2 | 49 | Pump Down Alarm |
| 13 | Voltage Sensor 3 | 50 | High Side Flood Back |
| 20 | Lost Phase | 80 | RTC warning, date no correct |
| 21 | Phase Sequence | 81 | RTF warning, communication with clock |
| 22 | Phase Imbalance | 82 | Probe Configuration |
| 23 | Over Current | 83 | Di Configuration |
| 24 | Open Run circuit | 84 | Compressor Configuration |
| 25 | Open Start circuit | 85 | Injection Probe Configuration |
| 26 | Under Voltage | 86 | EEPROM R/W (manual) |

E-Error L=Lockout