

ENGLISH

Trex[®]

2011 INSTALLATION GUIDE
TREX[®] DECKING
AND RAILING

Building your **OUTDOOR HOME**

DECKING AND RAILING



TREX TRANSCEND® DECKING AND RAILING
Striking beauty and unmatched performance that outdecks all others



TREX ESCAPES® DECKING AND TRANSCEND RAILING
Outstanding performance in natural, earth-tone colors



TREX ACCENTS® DECKING WITH TRANSCEND AND TREX DESIGNER SERIES RAILING®
Elegant beauty of a soft, subtle wood grain

ALSO AVAILABLE: TREX® ADA HAND RAIL
Complementary and compliant

Trex® Installation Guide

In your hands, you're holding everything you need to begin building with Trex® decking and railing. This step-by-step guide will show you how to create a beautiful outdoor living space that fits perfectly into your or your client's lifestyle.

Trex has been proven in the field. After almost twenty years of unparalleled performance, it offers warm, natural beauty and inviting comfort that no other product can match. Maybe that's why Trex is asked for by more customers than any other brand in the business.



From time to time, Trex revises its installation instructions. To ensure you have the most up-to-date installation instructions, please visit trex.com.

TREX® INSTALLATION GUIDE CONTENTS

SECTION ONE: General Information

- General Tips.....5
- Trex DeckLighting™.....5
- Trex CustomCurve™ (Bending Trex).....5
- Job Site Storage.....5
- Safety.....6
- Tools.....6
- Care and Cleaning.....7
- Mold Technical Bulletin.....9
- Painting Technical Bulletin.....10
- Physical and Mechanical Properties.....11
- Glossary of Terms.....13

SECTION TWO: Decking

- Decking Specifications and Profiles.....15
- Decking Fasteners.....16
- Framing and Fastening Tips.....17
- Special Patterns.....18
- Rooftop Decks and Sleeper Systems.....18
- Code Compliance.....19
- Gapping.....20
- Stairs.....21

How to Install Decking

- Tips for Installing a Trex Hideaway® Hidden Fastener System (Stainless steel or Universal).....22
- How to Install Trex Hideaway Stainless Steel Fasteners.....23
 - Parts List.....23
 - Tools Needed.....23
- How to Install Trex Hideaway Universal Hidden Fasteners.....24
 - Parts List.....24
 - Tools Needed.....24
- How to Install Escapes® Boards with Trex Universal Fasteners.....25
- How to Replace Trex Boards (With Stainless Steel or Universal Fasteners).....25
- How to Install Stair Treads (with Stainless steel or Universal Hidden Fasteners).....26
- How to Install Post Mounts on Deck Board.....27
- How to Install Post Mounts on Concrete.....29

SECTION THREE: Railing

- Trex Transcend® Railing Specifications and Profiles.....31
- Trex Transcend Railing Systems.....32
- Designer/Traditional Railing Specifications and Profiles..33
- ADA Railing Specifications and Profiles.....34

How to Install Railing

- Trex Transcend® Railing**.....35
 - Parts List.....35
 - Trex Transcend Railing Styles.....36
 - Trex Transcend Railing Installation.....37
 - Standard.....37
 - Classic.....39
 - Colonial.....40
 - Glass Panel.....41
 - Customizing Your Deck.....42
 - How to Install On-an-Angle Railing.....42
 - How to Install Bird's Mouth Railing.....43
 - How to Install Top Rail Caps.....44
 - How to Install Stair Railing.....45
 - How to Install Foot Blocks.....47

- Trex Designer Series Railing®**.....48
 - Parts List.....48
 - Designer Railing Styles.....48
 - How to Install Standard Railing.....49
 - How to Install Contemporary Railing.....52
 - How to Install Standard Stair Railing.....54
 - How to Install Contemporary Stair Railing.....56

- Trex® Traditional Railing**.....58
 - Parts List.....58
 - Traditional Anchored Railing Style.....59
 - Traditional Raised Railing Styles.....59
 - How to Install Anchored Railing.....60
 - How to Install Raised Railing
 - Rails Mounted on Sides of Post/Option 1.....61
 - Rails Mounted Between Posts/Option 2.....63
 - How to Install Raised Stair Railing/Anchored, Option 1, and Option 2.....64
 - How to Install Raised Railing
 - Rails Between Posts/Option 3-Contemporary.....65
 - How to Install Raised Stair Railing/Option 3-Contemporary.....67
 - How to Install Raised Railing
 - Rails Between Posts/Option 4-Architectural.....69
 - How to Install Raised Stair Railing/Option 4-Architectural.....71

- Trex ADA Railing**.....72

SECTION FOUR: Warranties

- Trex Transcend 25-Year Limited Residential Fade and Stain Warranty.....77
- Trex Transcend 10-Year Limited Commercial Fade and Stain Warranty.....79
- 25-Year Limited Residential Warranty.....81
- 10-Year Limited Commercial Warranty.....82
- Color Palette.....Inside Back Cover

GENERAL TIPS

- » Most colored chalk lines are permanent. **Use baby powder or Irwin Strait-Line® Dust-Off Marking Chalk available at Irwin.com**
- » We **DO NOT** recommend sanding. Sanding will change the appearance of the surface of Trex material and **will void the warranty with respect to any condition caused by such sanding.**
- » When drilling large or deep holes, periodically lift the bit out of the hole to remove the shavings.
- » Throughout this guide, feet are converted to meters and inches to centimeters.
- » If you want to minimize the appearance of joists through the spaces between boards, paint the top of your joists black.
- » Trex® decking and railing is suitable for a wide range of applications. It is not intended for primary structural members such as load bearing columns, joists, stringers, and beams.
- » Construction methods are always improving. Please make sure you have the most up-to-date installation instructions by visiting trex.com.

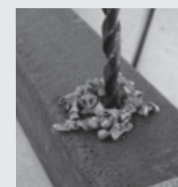

Trex® Deck Lighting™

(For use with Trex Transcend® only.)

Trex DeckLighting coordinates with our color collection for a professional, seamless look. It's a beautiful finishing touch for the decking, railing, and trim materials that you already trust.

Find more information, including installation instructions and warranty information, by visiting trex.com.



Trex® CustomCurve™

HEATING & BENDING SOLUTION

Trex is the first brand to have a bending solution exclusively for contractors, giving you the ability to create those unique, showpiece decks that are unmistakably Trex.** For more information, visit trexpartners.com.

*Strait-Line is a registered trademark of Irwin Industrial Tool Company.

**Trex® CustomCurve™ is manufactured and distributed by Curvelt, LLC. Trex® and CustomCurve™ are trademarks of, and are used by Curvelt, LLC under a license with Trex Company, Inc.

JOB SITE STORAGE

Remember when storing Trex® decking, railing, fencing, and trim:

- » You must store Trex outdoor-living products on a flat and level surface. Adjust support blocks accordingly.
- » You must support Trex products with dunnage when placing bundles.
- » When stacking Trex products, supports should start at each end and be spaced 2' (0.61 m) on center. Supports should line up vertically.
- » **DO NOT** stack Trex higher than six bundles (units) or 12' (3.7 m) high.
- » **Cover material on site until you are ready to install it.**

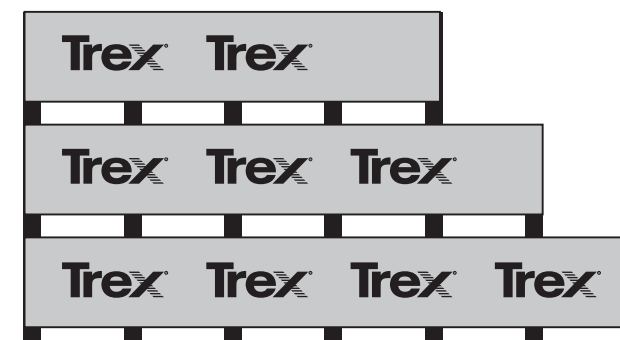

Units of Trex lumber on level ground.

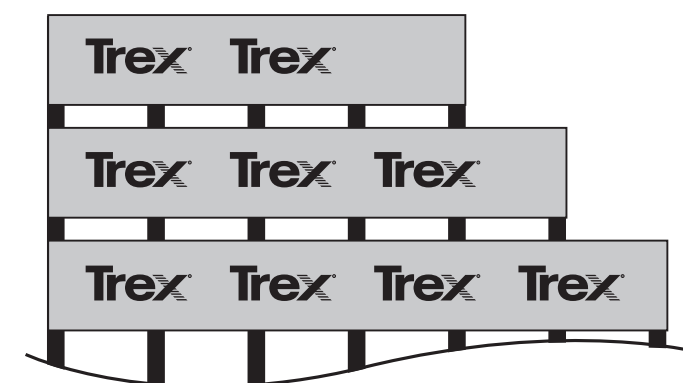

Units of Trex lumber on uneven ground.



ALWAYS GREEN: Trex decking is made of 95% recycled materials, including plastic shopping bags, reclaimed wood, and sawdust.

SAFETY

When working on any construction project, you should wear protective clothing and safety equipment. Wear safety glasses, gloves, a dust mask and long sleeves, particularly when cutting in confined spaces.

Trex® decking and railing are heavier and more flexible than wood. **DO NOT** try to lift the same quantity of Trex boards as you would traditional lumber. Go to *Trex.com* for Material Safety Data Sheets (MSDS).

TOOLS

You can create intricate shapes, profiles, and patterns with Trex. Most installments require no special tools. For best results, use carbide-tipped blades and router bits.

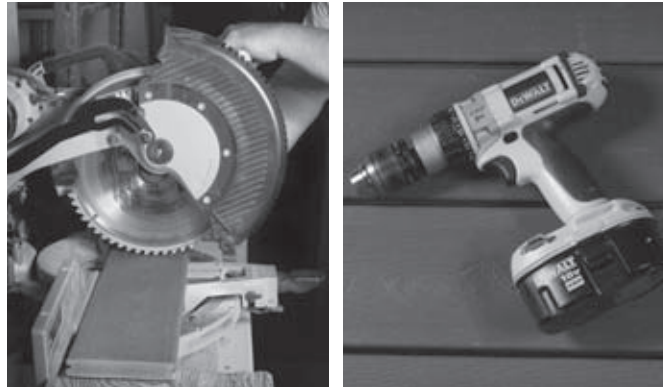

When using a miter saw, we recommend a 10" - 12" (25.4 cm - 30.5 cm) saw blade with 40 teeth or less. When cutting Trex Transcend® Railing or Trex Escapes®, we recommend using a 60-tooth carbide-tipped blade.

Install Trex recommended fasteners with standard power drills.



Screw and nail guns provide a quick and easy way to fasten Trex.

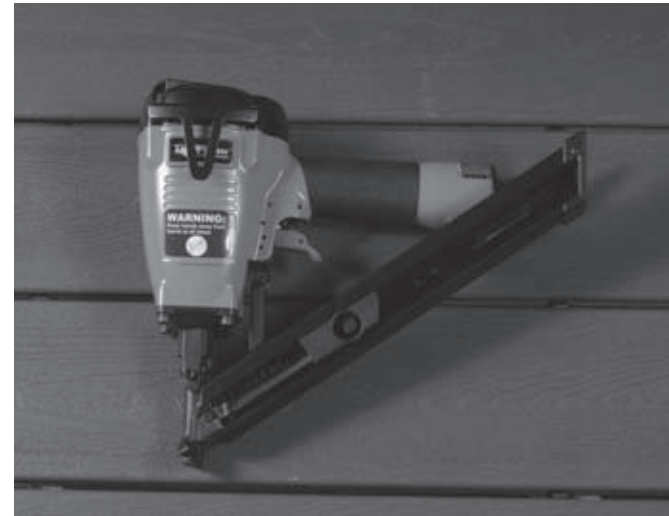

The pneumatic gun by Tiger Claw®* is designed to dramatically decrease the time it takes to install a deck. Strong, lightweight, and durable, the gun uses Trex Hideaway® fasteners. Trex Gun Pail includes 900-count connector clips and TC-SG collated pneumatic screws.

Trex routs beautifully to give extremely crisp edges. The groove cutter/router bit is used with the Trex Hideaway fastener system.

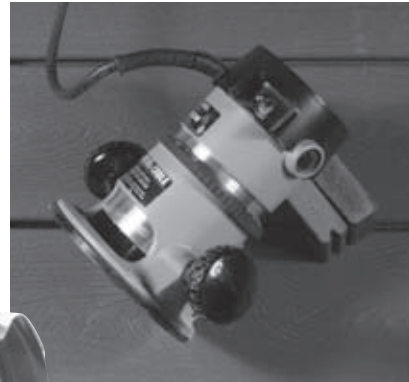

⚠ CAUTION

DO NOT rout balusters, 4" x 4" (10.2 cm x 10.2 cm) Trex Railpost™ and Trex Escapes profiles. Routing will change the surface of Trex products.

*Tiger Claw is a registered trademark of Tiger Claw, Inc.

TREX TRANSCEND® CARE AND CLEANING GUIDE

All exterior building materials require cleaning. Periodic cleaning of Trex Transcend® decking and railing will maintain the beauty of the deck. Periodically removing pollen and other debris from the deck surface will help reduce mold growth on the biofilm.

PROBLEM	SOLUTION
Dirt and Debris	The affected area should be sprayed off with a hose to remove surface debris. Use warm soapy water and a soft bristle brush to remove dirt and debris from the embossing pattern.
Chalk Lines	High permanence chalk lines may discolor the surface. Use only Irwin Strait-Line®* Dust-Off Marking Chalk (purple), available at <i>Irwin.com</i>
Tannins Due to Debris	Remove all debris from the deck using a hose or broom. Once the deck surface is dry, apply a "deck brightener"*** to the deck as directed by the manufacturer. Deck brighteners contain oxalic acid, which will remove tannins.
Ice and Snow	A plastic shovel may be used to remove snow from the deck. Use calcium chloride or rock salt to melt the snow and ice from the deck surface.
Oil/Grease/Food	All food spills should be removed as soon as possible. The surface must be cleaned within seven days to maintain the stain warranty. To remove, spray off with a hose and use warm, soapy water and a soft bristle brush to remove spills from the embossing pattern.
Mold and Mildew	If debris such as pollen and dirt is allowed to remain on the deck surface, mold can feed on the biofilm. Using a hose and warm soapy water with a soft bristle brush is recommended to remove the food source and mold.
Using a Pressure Washer	A 1500 psi power washer may be used on Transcend shell surface to remove dirt and debris. Use a fan tip at least 4" (10.2 cm) away from the shell when you are using a power washer.
Maintaining Transcend® Railing	NEVER use acetone or other solvents on Trex Transcend railing to maintain the beauty of the surface. For white railings, we suggest using Magic Eraser®.*** For colored railings, a sponge with soap and hot water is all that should be needed.
Concrete or Stucco Dust	Scrub with a long handled medium soft brush with soap and water. Then pressure wash using guidelines above. If pressure washer has soap attachment, use this. THOROUGHLY RINSE. If not rinsed properly, the water when allowed to dry will have residue and will need to be cleaned a second time.

*Strait-Line is a registered trademark of Irwin Industrial Tool Company.

**Use of products containing bleach or acid will lighten the surface of Trex. Use in an inconspicuous area to determine whether you like the effect. Neither product will affect the structural integrity of Trex.

***Magic Eraser is a registered trademark of The Procter and Gamble Company.

TREX® DECKING AND RAILING GENERAL CARE AND CLEANING GUIDE (COMPOSITE AND PVC)

All exterior building materials require cleaning. Trex recommends basic cleaning with soap and hot water or a commercially available deck cleaner twice a year. This will help maintain the beauty of Trex decking, fencing, railing, and trim.

PROBLEM	SOLUTION
Dirt and Debris	Clean deck to remove dirt and debris. Soap and hot water is all that is needed.
Chalk Lines	Most colored chalks are permanent. For Trex use either baby powder or Irwin Strait-Line®* Dust-Off Marking Chalk available at Irwin.com
Visible Printing	The printing on the side of Trex decking boards are required by building codes. With careful installation, most printing can be hidden. Visible printings can be lightened with acetone.
Water Spots, Leaf Staining and Wood Tannins	Tannin leaching occurs naturally in Trex and all wood-based products. Allow for at least 12 weeks of normal weathering. This process may be hastened through the use of a product containing oxalic or phosphoric acid, commonly known as Deck Brightener.**
Ice and Snow	Calcium chloride or rock salt, available in many home centers, will melt ice on Trex decking. Rinse off when first practical. Use caution when removing snow or ice with a snow shovel, and NEVER use a metal snow shovel on a Trex deck. A shovel may scratch the deck, which is not covered under warranty .
Scuffs and Abrasions	Scuffs and abrasions can fade or disappear naturally after 12 - 16 weeks of weathering. This can be accelerated with a product containing oxalic or phosphoric acid, also known as Deck Brightener.
Rust Stains, Ground-In Dirt and Grime and Pigment Staining	Use a cleaning product containing oxalic or phosphoric acid base, also known as Deck Brightener, to lighten or remove rust or dirt. Product may need to sit on the stain for 10 - 15 minutes before rinsing.**
Oil/Grease/Food	Rinse the stain with hot water as soon as possible. Use Pour-N-Restore®*** (pour-n-restore.com) as directed for any remaining stain. (Test in a small area first as Pour-N-Restore may remove some of the colorant from the decking surface.)
Mold and Mildew	Semi-annual (spring and fall) cleaning of your deck is important to prevent the buildup of pollen and other debris that can support the growth of mold. Use conventional deck washes or cleaners that contain sodium hypochlorite (bleach) and detergent (refer to <i>Mold Technical Bulletin on page 9</i> for specific recommendations).** NOTE: Trex Escapes® can be effectively cleaned by using a hose and warm, soapy water with a soft bristle brush.
Using a Pressure Washer	Trex does not recommend the use of a pressure washer. The use of a pressure washer with a greater than 1,500 psi and/or applied closer than 12" (30.5 cm) from the deck surface could damage the decking surface and will void the warranty with respect to any condition caused by the pressure washing.
Sanding	Trex does not recommend sanding. Sanding will change the appearance of the surface of Trex material and will void the warranty with respect to any condition caused by such sanding.
Disposal	Trex decking and railing products should be disposed with normal construction debris or household waste. DO NOT burn Trex products.

*Strait-Line is a registered trademark of Irwin Industrial Tool Company.

**Use of products containing bleach or acid will lighten the surface of Trex. Use in an inconspicuous area to determine whether you like the effect. Neither product will affect the structural integrity of Trex.

*** Pour-N-Restore is a registered trademark of Edgewater Industries.

NOTE: Trex does not recommend the placement of rubber or vinyl materials such as those in grill mats, rubber-backed welcome mats, vinyl or PVC potted containers, etc., on the surface of Trex Escapes® for extended periods of time. Over time, additives in the rubber and PVC products have a tendency to migrate from these materials to Trex Escapes, resulting in discoloration of the surface.

MOLD TECHNICAL BULLETIN

Mold is a lower form of plant life that can settle and grow on any surface, including Trex® decking. Mildew is a form of mold that grows on damp surfaces.

Mold spores, transported by air, insects, animals, and water, are similar to seeds, but you can't see them until colonies form. Because mold adapts easily to its environments and has a large number of species, it is hard to control and impossible to eliminate totally. But it will not affect the structural performance of Trex decking.

To form visible colonies, mold needs food, moisture, and temperatures between 40° - 90°F (4°C - 32°C). Trex decking is not itself a food source but spilled dirt and debris from flowerpots and gutters can nourish mold. If the gaps between deck boards are too small or clogged, the decking can also supply moisture. Refer to *gapping instructions on page 20*.

How to Remove Mold from Trex Composite and PVC Decking

All exterior building materials require cleaning. Trex is no exception. Periodic cleaning of Trex decking will remove dirt and pollen that can feed mold. If mold colonies appear, clean the deck with a commercial deck wash containing a detergent and sodium hypochlorite (bleach). The chemical will remove the mold but also lighten the wood. In some cases, it will take several treatments to remove the mold colonies. Even if the spots are no longer visible, mold spores that could re-grow may still be on the surface.

The following brands of deck cleaners are effective in removing mold:

- » Olympic® Premium Deck Cleaner*
- » Expert Chemical™** Composite Deck Cleaner and Enhancer (expertchemicalinc.com)

Always apply these products to a dry deck. Applying them to a wet deck will significantly reduce the bleach's effectiveness. **NEVER** mix any other cleaners (ammonia, phosphoric acid, etc.) with bleach.

- » For a non-chlorine based alternative, you can use UltraMean®,*** but you must scrub the deck with a soft brush immediately after you apply the cleaner.

If you prefer an eco-friendly product, the following will reduce the appearance of mold on the decking surface:

- » Corte-Clean® **** Composite Deck Cleaner (corteclean.com)



Mold spreads easily and may return in some environments despite proper cleaning and preventative measures. Mold does not damage Trex and will cause no structural harm.

How to Remove Mold from Trex Transcend® Decking

If you allow debris such as pollen and dirt to remain on the deck surface, mold can feed on the biofilm. Use a hose and warm soapy water with a soft bristle brush to remove the food source and mold.

* Olympic® is a registered trademark of PPG Architectural Finishes, Inc.

** Expert Chemical™ is a trademark of Expert Chemical, Inc.

*** UltraMean® is a registered trademark of Rhino Hide.

**** Corte-Clean® is a registered trademark of Corte LLC.

PAINTING TECHNICAL BULLETIN

Can standard Trex® composite decking and railing be painted?

Yes, you can paint or stain Trex decking or railing to achieve a custom color, but it is not necessary for protection. Paints and stains that adhere well to wood will work as well or better with Trex products. Trex decking that has been faded can be painted or stained at any time, even years after it has been installed. However you should use paint or stain that is made for a walking surface.

NOTE: Trex Transcend® decking or railing and Trex Escapes® cannot be painted or stained.*

What types of paints and stains can I use?

Most paints or stains that you would apply to wood can be applied to Trex decking. The following companies have evaluated Trex decking and suggested these coatings:

MANUFACTURER SUGGESTED STAINS		
Paint Manufacturer	Tech Support Phone Number	Suggested Coating
Behr	800-854-0133	Premium Plus®** Exterior Solid Wood Deck Stain (no primer needed)
Sherwin Williams	800-474-3794	S-W Deckscapes®*** Exterior Acrylic Deck Stain A15-150 Series S-W Woodscapes®*** Exterior Acrylic Deck Stain A15 Series

Should I wait until my Trex decking is faded before applying paint or stain?

Yes, it is important to wait for Trex to fade (about 12 - 16 weeks) before applying paint or stain. If the Trex decking is painted or stained before it fades, the paint or stain could become discolored and adhesion may be compromised. The discoloration is not permanent and can be cleaned.

Once I've picked out my paint or stain, what do I do?

Use this easy three-step process:

- » Wait until the Trex decking fades, approximately 12 - 16 weeks.
- » Clean your Trex decking surface. **NEVER** paint or stain over dirty surfaces or surfaces with mold and mildew. Refer to pages 7 - 8 for cleaning instructions.
- » Apply the paint or stain in accordance with the manufacturer's directions.

How long will the paint or stain on my deck last?

This depends on the paint or stain, but testing has shown that paints or stains on Trex decking will last as long as or longer than paints or stains on wood. Because Trex decking absorbs minimal moisture, the paint or stain will not experience checking or splitting.

What about cleaning my painted or stained Trex decking?

Consult your paint or stain manufacturer's directions before cleaning.

How can I restore colorant on my decking surface?

A product called Penofin®**** Knotwood®**** Composite Decking Colorant works well if you are interested in restoring or enhancing your decking color. This product comes in three different shades so you can determine the best color match for your existing decking. For example, we would recommend using the color "Redwood" for Brasilia Cayenne or Madeira.

For more information about colors and application, refer to www.penofin.com/products_knotwood.shtml.

NOTE: This product cannot be applied to Trex Transcend® decking or Trex Escapes®.



*If there is an ADA requirement for slip resistance, an appropriate type of paint with grit or grit additive can be applied. For standard Trex decking products, a product like Benjamin Moore®***** Anti-Slip 116 (note this is not clear-based) or an equivalent anti-slip alternative will provide an abrasive coating to materials for ramps that must meet ADA requirements. For Transcend decking, a latex or acrylic-based paint will not adhere but oil-based paint with grit will adhere and provide proper friction properties.

**Premium Plus is a registered trademark of the Behr Process Corporation.

***Deckscapes and Woodscapes are registered trademarks of The Sherwin-Williams Company.

****Penofin and Knotwood are registered trademarks of Performance Coatings, Inc.

*****Benjamin Moore is a registered trademark of Benjamin Moore & Company.

PHYSICAL AND MECHANICAL PROPERTIES FOR TREX TRANSCEND®

	TEST METHOD	VALUES	
Flame Spread (a)	ASTM E84	60	
Typical Trex® Values for Coefficient of Thermal Expansion/Contraction (36" (91.4 cm) long samples)			
Thermal	Width	35.2 x 10 ⁻⁶ to 42.7 x 10 ⁻⁶ (inch/inch/°F) 644 x 10 ⁻⁶ to 776 x 10 ⁻⁶ (length/length/°C)	
	Length	16.1 x 10 ⁻⁶ to 19.2 x 10 ⁻⁶ (inch/inch/°F) 297 x 10 ⁻⁶ to 356 x 10 ⁻⁶ (length/length/°C)	
Moisture	Typical Trex Values for Long-Term Water Immersion (36"/91.4 cm long samples)	Typical Trex Values for Constant High Humidity (6"/15.2 cm long samples)	
			Width ~3% ~1%
Nail Withdrawal (c)	ASTM D1761	163 lbs/in (1.12 Mpa)	
Screw Withdrawal (c)	ASTM D1761	558 lbs/in (3.85 Mpa)	
Fungus Resistance (White & Brown Rot)	ASTM D1413	Rating = No Decay	
Termite Resistance (d)	AWPAE1-72	Rating = 9.6	
		ULTIMATE (TYPICAL) VALUES	DESIGN VALUES
Compression Parallel (e)(f)	ASTM D198	836 psi (5.76 Mpa)	540 psi (3.72 Mpa)
Compression Perpendicular (e)(g)	ASTM D143	861 psi (5.94 Mpa)	540 psi (3.72 Mpa)
Tensile Strength (e)	ASTM D198	1562 psi (10.77 Mpa)	500 psi (3.45 Mpa)
Shear Strength (e)	ASTM D143	559 psi (3.85 Mpa)	360 psi (2.48 Mpa)
Modulus of Elasticity (e)	ASTM D4761	412,000 psi (2840.64 Mpa)	200,000 psi (1378.95 Mpa)
Thermal Conductivity	ASTM C177	1.57 BTU-in/hr-ft @85°F (.0023 W/cm/°C)	

NOTES:

- (a) Corresponding Smoke Developed Index is 285.
- (b) Values shown are for reference only. These values should not be used to calculate gapping for Trex. Follow Trex installation literature for proper width-to-width and end-to-end gapping information.
- (c) 8d common wire nail. No. 10 wood screw.
- (d) Material weight loss was 0%.
- (e) Ultimate strength values are not meant for design analysis. Testing performed on a 1" x 5.5" (2.5 cm x 14 cm) cross section. Design values are for temperatures up to 130°F (54°C).
- (f) Compressive strength parallel to the length.
- (g) Compressive strength perpendicular to length.

PHYSICAL AND MECHANICAL PROPERTIES FOR TREX ACCENTS®, BRASILIA®, CONTOURS®, AND ORIGINS®

	TEST METHOD	VALUES	
Abrasion Resistance	ASTM D2394	.01 wear/1000 revs.	
Hardness	ASTM D143	562 kg (5 kn)	
Self-Ignition Temperature	ASTM D1929	743°F (395°C)	
Flash-Ignition Temperature	ASTM D1929	698°F (370°C)	
Flame Spread (a) [Fire Defense]™	ASTM E84	80 [40]	
Water Absorption (sanded surface) 24 hr. immersion	ASTM D1037	4.3%	
Water Absorption (unsanded surface) 24 hr. immersion	ASTM D1037	1.7%	
Typical Trex® Values for Coefficient of Thermal Expansion/Contraction (36" (91.4 cm) long samples)			
Thermal	Width	35.2 x 10-6 to 42.7 x 10-6 (inch/inch/°F) 644 x 10-6 to 776 x 10-6 (length/length/°C)	
	Length	16.1 x 10-6 to 19.2 x 10-6 (inch/inch/°F) 297 x 10-6 to 356 x 10-6 (length/length/°C)	
Moisture	Typical Trex Values for Long-Term Water Immersion (36"/91.4 cm long samples)	Typical Trex Values for Constant High Humidity (6"/15.2 cm long samples)	
	Width -3%	-1%	
Nail Withdrawal (c)	ASTM D1761	163 lbs/in (1.12 Mpa)	
Screw Withdrawal (c)	ASTM D1761	558 lbs/in (3.85 Mpa)	
Static Coefficient of Friction - Dry (d)	ASTM D2047	0.53/0.55	
Static Coefficient of Friction - Dry (d)	ASTM F1679	0.59/0.70	
Static Coefficient of Friction - Wet (d)	ASTM F1679	0.70/0.75	
Fungus Resistance (White & Brown Rot)	ASTM D1413	Rating = No Decay	
Termite Resistance (e)	AWPAE1-72	Rating = 9.6	
Specific Gravity (typical)	ASTM D2395	0.91 to 0.95	
		ULTIMATE (TYPICAL) VALUES	DESIGN VALUES
Compression Parallel (f)(g)	ASTM D198	1806 psi (12.45 Mpa)	550 psi (3.79 Mpa)
Compression Perpendicular (f)(h)	ASTM D143	1944 psi (13.40 Mpa)	625 psi (4.31 Mpa)
Tensile Strength (f)	ASTM D198	854 psi (5.89 Mpa)	250 psi (1.72 Mpa)
Shear Strength (f)	ASTM D143	561 psi (3.87 Mpa)	200 psi (1.38 Mpa)
Modulus of Rupture (f)	ASTM D4761	1423 psi (9.81 Mpa)	250 psi (1.72 Mpa)
Modulus of Elasticity (f)	ASTM D4761	175,000 psi (1206 Mpa)	100,000 psi (689.48 Mpa)
Thermal Conductivity	ASTM C177	1.57 BTU-in/hr-ft @85°F (.0023 W/cm/°C)	
Leachate (i)	TCLP-EPA 1311	Pass	

NOTES:









- (a) Corresponding Smoke Developed Index is 285.
- (b) Values shown are for reference only. These values should not be used to calculate gapping for Trex. Follow Trex installation literature for proper width-to-width and end-to-end gapping information.
- (c) 8d common wire nail. No. 10 wood screw.
- (d) ASTM D2047 test conducted on sanded/unsanded unweathered samples with leather surface. ASTM F1679 test conducted on sanded/unsanded weathered samples with neolite surface.
- (e) Material weight loss was 0%.
- (f) Ultimate strength values are not meant for design analysis. Testing performed on a 1" x 5.5" (2.5 cm x 14 cm) cross section. Design values are for temperatures up to 130°F (54°C).
- (g) Compressive strength parallel to the length.
- (h) Compressive strength perpendicular to length.
- (i) Leaching was below levels established by EPA for all constituent categories.

GLOSSARY OF TERMS

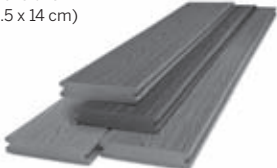
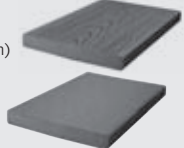
- Baluster** One of a number of closely spaced supports for a railing.
- Baluster Spacer** A piece that snaps into top and bottom rail that gives precise spacing to the balusters.
- Bird's Mouth Gasket** A 45° corner cut gasket to be used when attaching railing to the corner of a 4" x 4" (10.2 cm x 10.2 cm) post sleeve.
- Bump Stop Tab** Part of the connector clip and allows for 1/4" (0.6 cm) spacing between decking boards.  **Bump Stop Tab**
- Carriage Bolt** A bolt with a rounded head and a square shoulder under the head to prevent turning during installation.
- Connector Clip** Hidden fastener used between deck boards to secure positioning.
- Fascia** Horizontal trim board used to cover rim and end joists. May also be used for stair risers.
- Foot Block** Provides support for the bottom rail and gives a finished appearance.
- Joist** A horizontal structural pressure-treated board that runs from wall-to-wall, wall-to-beam, or beam-to-beam to support the deck floor and decking materials.
- Lag Bolt** A large metal fastener with a hex head and screw threads that drive it into the wood.
- Ledger Board** A beam supporting one end of the joists.
- Nosing** The rounded front edge of a stair tread.
- Pan-head Screw** Self-tapping screw with W-cut design and slightly rounded head.
- Post Sleeve** Formed sleeve that fits over a standard pressure-treated 4 x 4 post.
- Post Sleeve Cap** Attractive flat or pyramid shaped cap to place on top of post sleeve.
- Post Sleeve Skirt** Decorative skirt that surrounds the bottom of the post and rests on surface of deck.
- Rail Gasket** A gasket used to fill the gap between the railing and post.
- Railpost™** A solid 4" x 4" (10.2 cm x 10.2 cm) Trex post used in conjunction with Trex Designer Series Railing® or Trex Traditional Railing.
- Railpost Cap** Attractive flat or pyramid shaped cap to place on the top of the railpost.
- Railpost Skirt** Decorative skirt that surrounds the bottom of the railpost and rests on the surface of the deck.
- Rail Support Bracket (RSB)** Innovative bracket designed for horizontal, angled, and stair railing installations.
- Rim Joist** A joist on either side or the end of the deck. May have stairs attached and typically opposite of the ledger board.
- Riser** The vertical board nailed to a stringer.
- Scarf Cut** A joint used to join two pieces of decking end-to-end, usually cut at a 45° angle.
- Screw Plug** A small plug to cover a screw.
- Self-tapping Screw** A fastener that taps and drills its own hole and does not require a pre-drilled hole.
- Shim** A wedge that is placed between two surfaces to fill in the gap.
- Stair Tread** Steps or stairway boards that are the steps.
- Start Clip** Metal clips used at the end of decking boards to secure them in position.
- Stringer** The structural member in a stairway that supports the treads and risers.
- Tempered Glass** A safety glass that is four to five times stronger than standard glass made by a process of extreme heating and cooling.
- Toenailing** Attaching two pieces of decking together by driving a nail at an angle through one piece into the other.
- Universal Fastener** Plastic 1/4" (0.6 cm) self-gapping hidden fastener that has increased durability and allows for easier and faster installation than traditional fasteners.
- Wall Return Fitting** A fitting that can attach directly to wall or post.
- Weather Stripping** A self-adhesive strip applied to the glass panel option to create a tight fit with top and bottom rails.

DECKING

DECKING SPECIFICATIONS AND PROFILES

DECKING	DESCRIPTION	ITEM NUMBER	COLORS	
1" x 6" (2.5 cm x 15.2 cm) Square Edge Board Actual Dimensions: 1" x 5.5" (2.5 cm x 14 cm) 	12' (3.66 m) 16' (4.88 m) 20' (6.1 m)	Transcend Transcend Transcend	XX010612TS48 XX010616TS48 XX010620TS48	TH, VL, GP, FP, SR, LR
	12' (3.66 m) 16' (4.88 m) 20' (6.1 m)	Escapes Escapes Escapes	XX010612ES48 XX010616ES48 XX010620ES48	AC, PW
	12' (3.66 m) 16' (4.88 m) 20' (6.1 m)	Accents Accents Accents	XX010612AS48 XX010616AS48 XX010620AS48	WG, WB, MB, SD
2" x 4" (5.1 cm x 10.2 cm) Square Edge Board Actual Dimensions: 1.5" x 3.5" (3.8 cm x 8.9 cm)	12' (3.66 m) 16' (4.88 m)	Transcend Transcend	XX020412TS48 XX020416TS48	FP, VL, TH, GP
	16' (4.88 m)	Smooth	XX020416OS120	WG, WB, MB, SD
2" x 6" (5.1 cm x 15.2 cm) Square Edge Board Actual Dimensions: 1.5" x 5.5" (3.8 cm x 14 cm) 	12' (3.66 m) 16' (4.88 m) 20' (6.1 m)	Transcend Transcend Transcend	XX020612TS32 XX020616TS32 XX020620TS32	FP, VL, TH, GP
	12' (3.66 m) 16' (4.88 m) 20' (6.1 m)	Accents Accents Accents	XX020612AS72 XX020616AS72 XX020620AS72	WG, WB, MB, SD
	12' (3.66 m) 16' (4.88 m) 20' (6.1 m)	Transcend Transcend Transcend	XX010612TG48 XX010616TG48 XX010620TG48	TH, VL, GP, FP, SR, LR
1" x 6" Grooved-Edge Board Actual Dimensions: 1" x 5.5" (2.5 x 14 cm) 	12' (3.66 m) 16' (4.88 m) 20' (6.1 m)	Transcend Transcend Transcend	XX010612EG48 XX010616EG48 XX010620EG48	TH, VL, GP, FP, SR, LR
	12' (3.66 m) 16' (4.88 m) 20' (6.1 m)	Escapes Escapes Escapes	XX010612AG48 XX010616AG48 XX010620AG48	AC, PW
	12' (3.66 m) 16' (4.88 m) 20' (6.1 m)	Accents Accents Accents	XX010612AG48 XX010616AG48 XX010620AG48	WG, WB, MB, SD
1" x 8' (5.1 cm x 2.44 m) Fascia Actual Dimensions: .75" x 7.25" x 12' (1.9 cm x 18.4 cm x 3.66 m) 	12' (3.66 m) 12' (3.66 m)	Transcend Smooth	XX010812TS60 XX010812OS60	TH, VL, GP, FP, SR, LR WG, WB, MB, SD
	1" x 12' (5.2 cm x 3.66 m) Fascia Actual Dimensions: .75" x 11.375" x 12' (1.9 cm x 28.9 cm x 3.66 m) 	12' (3.66 m) 12' (3.66 m) 12' (3.66 m)	Transcend Smooth Escapes	XX011212TS40 XX011212OS40 XXH1212B
TREX HIDEAWAY® HIDDEN FASTENER SYSTEM		DESCRIPTION	ITEM NUMBER	
Connector Clip (stainless steel) 	50 sq. ft. box 500 sq. ft. bucket	CONNECTCLIP CLIPPAIL		
Start Clip (stainless steel) 	400 sq. ft. bag	STARTERCLIP		
Universal Fastener (glass-filled nylon) 	50 sq. ft. box 500 sq. ft. bucket 50 sq. ft. box (only for use on Trex Escapes®)	UNIVCONCLIP DA00002 ESCAPESCLIP		
Router Bit/Groove Cutter 	Router Bit	ROUTBIT		
Gun Pail 	900 ct. connector clips and collated pneumatic screws	GUNCLIP		
XX = INSERT COLOR PREFIX:				
AC Acorn SR Spiced Rum	TH Tree House	FP Fire Pit VL Vintage Lantern	GP Gravel Path WB Woodland Brown	LR Lava Rock WG Winchester Grey
MB Madeira PW Pewter	SD Saddle			

DECKING FASTENERS

RECOMMENDED FASTENERS TO USE WITH TREX®								
	Trex Hideaway® Hidden Fastener	Phillips II Plus High Performance Composite Decking Screw*	FastenMaster® TrapEase® II Composite Screw**	Quik Drive® Composi-Lok™ Deck Screws***	UFO Ballistic NailScrews****	Dexxter™ Composite Screw*****	FastenMaster® TrimTop Hidden Fasteners**	Scrudini™ Hand Drive Screws*****
	800-289-8739 trex.com	888-332-6283 phillipsii.com	800-518-3569 fastenmaster.com	800-999-5099 strongtie.com	800-352-0028 479-443-9292 911-Nails.com	800-966-2801 swansecure.com	800-518-3569 fastenmaster.com	800-966-2801 swansecure.com
Transcend®	X	X	X					
Accents®	X	X		X	X	X		
Accents Fire Defense®	X	X	X	X	X	X		
Brasilia®	X	X	X	X	X	X		
Contours®	X	X	X	X	X			
Escapes®	X*						X	X

For best results, we recommend the above fasteners, which work well and provide an attractive appearance. Unless you are toe screwing, you will not have to pre-drill when you use these screws. See *Framing and Fastening Tips*, page 17.

MINIMUM FASTENER SIZE				
	SCREWS		NAILS	
Profile	Length	No.	Length	Gauge
1" x 6"	2-1/2" (6.4 cm)	#8, #10	2-1/2" (6.4 cm)	12
2" x 6"	3" (7.6 cm)	#8, #10	3" (7.6 cm)	12

1" X 6" (2.5 cm X 15.2 cm), 2" x 6" (5.1 cm x 15.2 cm)

FASTENING TIPS FOR TREX ESCAPES®*

You can fasten Trex Escapes® with the above fasteners at least 1/2" (1.25 cm) and not more than 4" (10.2 cm) from the board edge without splitting. **You do not have to pre-drill with Trex Escapes.**

***Use Trex Universal hideaway hidden fasteners for Escapes grooved product. Item #ESCAPESCLIP includes additional screws for installation.**

NOTE: When using pneumatic or battery-operated nailers, adjust the pressure so that you only shoot the head of the nail to be flush with the board's cap. **DO NOT** shoot the nail head completely through the cap.

If any condition occurs which is attributable to the use of non-recommended fasteners, such condition shall not be covered under Trex's Limited Warranty.

* Phillips II Plus High Performance/Pozisquare Composite Decking Screw.

** FastenMaster® TrapEase® II, and FastenMaster® TrimTop™ are registered trademarks of OMG, Inc.

*** Quik Drive® is a registered trademark and Composi-Lok™ is a trademark of Simpson Strong-Tie Company, Inc.

**** NailScrews® is a registered trademark of Universal Fastener Outsourcing, LLC.

***** Dexxter™ and Scrudini™ are trademarks of Swan Secure Products, Inc.

FRAMING AND FASTENING TIPS

Composite decking is a great alternative to traditional wood decking. When building your deck and railing, it is recommended that code-approved structural material be used as the framing and joists. Check your local building codes for restrictions. Trex® cannot be used for structural applications. **DO NOT** attach Trex decking directly to any solid surface or watertight system. See *Sleeper Systems on page 18*. In most cases, install fasteners at a 90° angle (perpendicular to the board).

At board ends on the deck's edge, you can install screws placed perpendicularly at the recommended distance—at least 1" (2.5 cm) and not more than 4" (10.2 cm) from the board edge and side—without splitting the board.

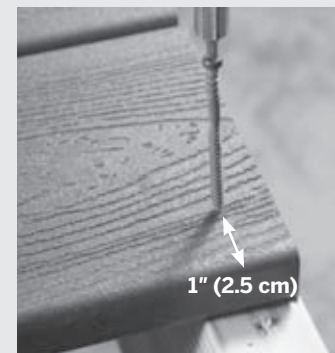

Trex does not have a linear grain like wood does and will not split if fasteners are started 1-1/4" (3.2 cm) from the board edges and angled into the joist. One inch (2.5 cm) will work but you should pre-drill the hole first. Pre-drilling will reduce the probability of splitting and dimpling near the fastener head. See page 20 for gapping guidelines.

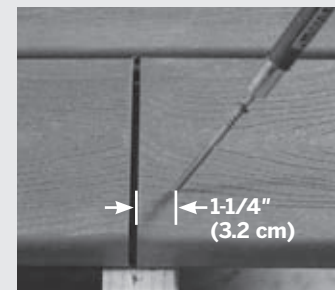

An alternative method for butt joints, where boards meet over a single joist, is to add a 2" x 4" (5.1 cm x 10.2 cm) "nailer" board at the butt joint. This allows you to install a screw at a 90° angle.



NOTE: Fasten board ends with at least two fasteners. Fasten at least one fastener at every joist in a zigzag pattern.

FASCIA FASTENING TIPS

- » Trex fascia around the base of a deck must be gapped the same as the decking to allow for air flow.
- » Attach the fascia every 12" (30.5 cm) with three Trex-approved screws. Place the top screw 1" (2.5 cm) from the top of the rim joist, the second screw at the rim joist's center, and the third screw 1" (2.5 cm) from the bottom of the rim joist.

HIDDEN FASTENER TIPS

Start Clips Needed

You will need 0.75 clips for every lineal foot of decking. For example, 40 feet of decking would require 30 start clips.

0.75 x ____ft of decking = # of start clips

CONNECTOR CLIPS NEEDED					
Joist Spacing (on center)	Deck Size Square Feet				
	100	200	300	400	500
12" (30.5 cm)	210	441	672	882	1113
16" (40.6 cm)	175	336	512	672	848
24" (66 cm)	110	231	352	462	583

NOTE: When using hidden fasteners (both start and connector clips), one must be used on every joist.

Calculating the Number of Connector Clips Needed

- » # of joists x # of decking boards = # of connector clips needed.
- » Ninety (90) connector clips will cover approximately 50 sq. ft. (103 cm²) using 5.5" (14 cm) decking boards on 16" (40.6 cm) centers.

PLANNING YOUR RAILING

It is important to prepare ahead of time for your railing installation.

- » First, pick the railing style you want.
- » Calculate your spanning.
- » Determine post locations prior to installing any decking. In most cases, posts are usually installed before decking is installed.

See pages 37 - 47 for Transcend railing installation, pages 49 - 57 for Designer railing installation, and pages 60 - 71 for Traditional railing installation.

SPECIAL PATTERNS

When planning a unique pattern, you will need to adjust the framing to support the surface pattern. Refer to the span and gapping charts on pages 19 and 20. Many decks are designed to take advantage of angles, as shown below.



Herringbone Pattern

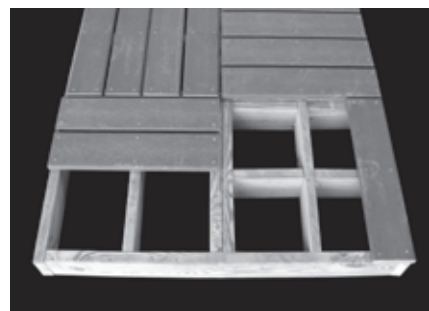

Tile Pattern



Picture Frame Pattern

ROOFTOP AND SLEEPER DECK SYSTEMS

Sleeper Deck Systems

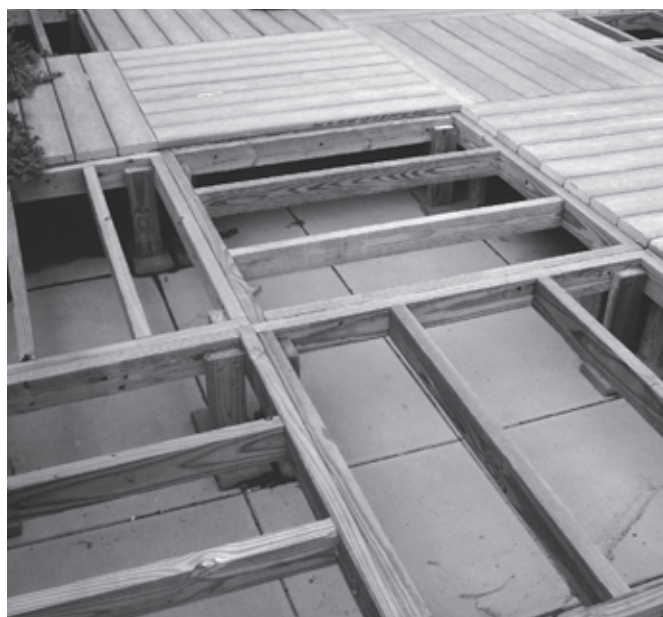

A sleeper system is a buffer between a solid surface and Trex® decking. Drainage, access, and airflow are critical. Water must be able to flow through and away from the deck. For repairs and removal of debris, joist system access is necessary. Good airflow will keep the decking dry and in good condition.

Trex, when used with a sleeper system, must be supported below its entire length and if used in a roofing application, the supports must run the direction of the pitch of the roof to facilitate proper drainage. In addition, sleeper joists must be attached to the roof structure in a manner that stabilizes the deck frame. Failure to do so may result in a poor structure which will compromise deck performance.

In areas of application where a sleeper system is required that would not be susceptible to excessive debris buildup (examples would include covered areas such as balconies, porches, etc.), a minimum height of 1-1/2" (3.8 cm) for pressure-treated joists as well as a minimum 1/4" (0.6 cm) gap between Trex decking would be acceptable. These areas would still have to be designed to allow for proper drainage and hidden fasteners would be acceptable. However, if access to the structure under the decking is required, it would be recommended to use either the Universal Fastener (plastic) or 2" (5.1 cm) composite decking screws. A 1/4" (0.6 cm) to 1/2" (1.3 cm) gap is still required when abutting walls or other fixed objects.

In all other areas where there could be excessive water buildup along with debris buildup, Trex would still recommend a minimum height of 3-1/2" (8.9 cm) for pressure-treated joists, as well as a gap of 3/8" (1 cm). For this application, hidden fasteners would not be recommended and standard 3" (7.6 cm) composite screws would be used.

ALWAYS consult your local building code authority for proper details on roof and railing installation to the roof structure if required.

ROOFTOP DECK TIPS

- » If you want to access the roof, you must build the Trex deck in removable sections or with removable fasteners.
- » You must attach the sleeper joists to the roof structure so that they stabilize the deck frame. Failure to do so may result in a poor structure which will compromise deck performance.

CODE COMPLIANCE

Joist Spanning for Decking

Trex® decking meets all applicable national model building codes. The joists must be spaced on center according to the chart below. Be sure that joists are level and plumb. Trex decking must span at least three joists. For heavy items such as hot tubs, planters, etc., consult a local building engineer or inspector for span recommendations. If you want to minimize the appearance of joists through the spaces between boards, paint the top of your joists black.

Code Listings

Trex complies with major model building codes and has been evaluated by the International Code Council evaluation service.

Trex Complies with these Model Building Codes:

- » 1997 Uniform Building Code (UBC).
- » 1999 Standard Building Code (SBC).
- » 2006 International Residential Code (IRC).
- » 2006 International Building Code (IBC).
- » International One and Two Family Dwelling Code 1998.
- » BOCA® National Building Code/1999 (BNBC).
- » Trex decking is included in the National Research Council of Canada's Registry of Product Evaluations. See trex.com for CCMC Evaluation Report 13125-R.

For an Materials Safety Data Sheet (MSDS), please visit trex.com

Trex Accents Fire Defense® and Trex Escapes®

Trex Accents Fire Defense®** and Trex Escapes® boards meet California and San Diego fire code requirements. For California, the requirements are that the board meets ASTM E84 Class B Flame Spread and 12-7A-4 Part A Underflame requirement. For San Diego, the requirements are that the board meets 12-7A-4 Part A Underflame and Part B Burning Brand (all parts). Trex Escapes meets ASTM E84 Class A Flame Spread and CA SFM 12-7A-4 Underflame and Burning Brand requirements. For more information, e-mail question@trex.com or call 1-800-BUY-TREX (1-800-289-8739). Trex Transcend® Lava Rock and Spiced Rum are compliant with the Wildland-Urban Interface, California State and San Diego County fire codes.**

ADJUST JOIST SPANNING TO ACCOMMODATE ANGLED DECKING PATTERNS*

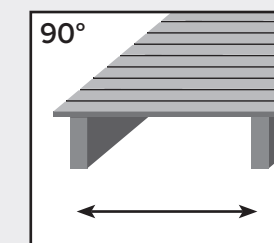

Perpendicular to joists. See chart below.

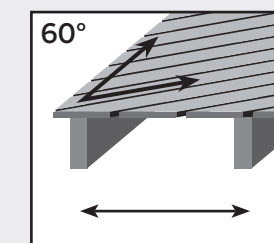

At a 60° angle, maximum joist spanning is 2" (5.1 cm) less than listed in the chart below.

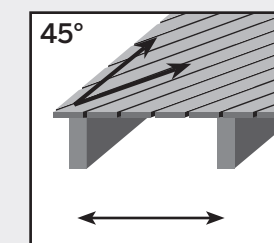

At a 45° angle, maximum joist spanning is 4" (10.2 cm) less than listed in the chart below.

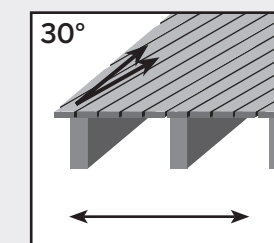

At a 30° angle, maximum joist spanning is 1/2 of the distance listed in the chart below.

TREX DECKING SPAN CHART (On Center)

Decking Loading	Residential Decks, Light Duty Docks, Residential/Day care Playground	Commercial Decks, Boardwalks and Marinas	
100psf (4826 Pa)	100psf (4826 Pa)	200psf (9576 Pa)	
1" (2.5 cm) Boards	16" (40.6 cm)	16" (40.6 cm)	12" (30.5 cm)
2" x 6" (5.1 cm x 15.2 cm) Boards	24" (70 cm)	24" (70 cm)	16" (40.6 cm)

TREX RAILING SPAN CHART

Maximum Railing Span for all Applications (on center of posts)	
Transcend Railing	96" (244 cm)
Designer Railing/ Traditional Railing	72" (183 cm)

* Only available in select areas.

** ASTM E84 Class B Flame Spread and CA SFM 12-7A-4 Underflame and Burning Brand requirements.

GAPPING

You must gap Trex® decking, both end-to-end and width-to-width. Gapping is necessary for drainage and the slight thermal expansion and contraction of Trex decking boards. Gapping also allows for the shrinkage of the wood joist system.

- » **ALWAYS** follow Trex-recommended gapping guidelines.
- » Maximum allowable perpendicular overhang for Trex is 4" (10.2 cm).
- » All decks require air circulation to keep them dry and looking good. To improve air flow, leave openings under the decking or increase gapping to 3/8" (1 cm).

WIDTH-TO-WIDTH GAP	
Above 40°F* (4.5°C)*	1/4" (0.6 cm)
Below 40°F* (4.5°C)*	3/8" (1 cm)

*Temperature at installation.

END-TO-END/END-TO-WIDTH AND ABUTTING GAP		
	End-to-End/ End-to-Width	Abutting Gap
Above 40° F* (4.5 C)*	1/8" (0.3 cm)	1/4" (0.6 cm)
Below 40° F* (4.5 C)*	3/16" (0.5 cm)	1/2" (1.3 cm)

*Temperature at installation.

- » When you use the recommended hidden fasteners, the placement of the hidden fastener establishes the designated gap size.
- » When installing fascia, gapping rules must apply.

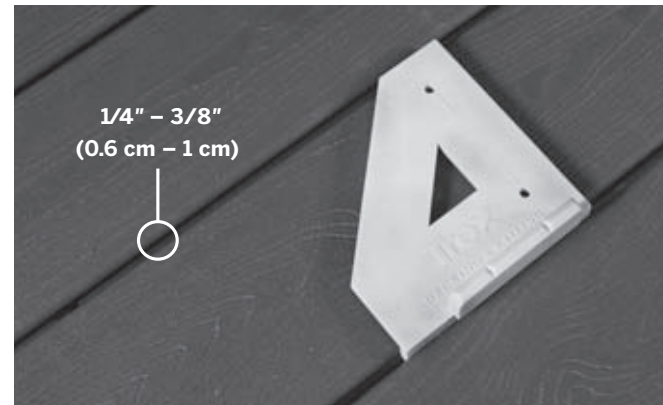

Width-to-Width

The minimum required width-to-width gapping is 1/4" (0.6 cm). When installing in temperatures below 40°F (4.5°C), Trex recommends 3/8" (1 cm) gapping. For docks and heavily wooded areas, Trex recommends a 3/8" (1 cm) gap as well. No gapping should ever exceed 1/2" (1.3 cm).

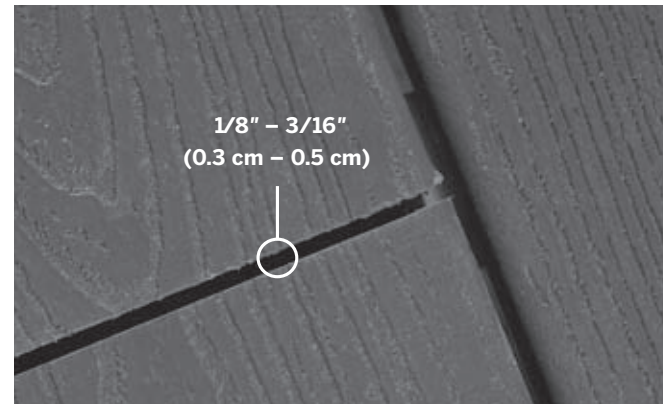

End-to-End/End-to-Width

Gap Trex decking end-to-end, based upon the temperature at installation. See chart at left. For fastening tips, see page 17.

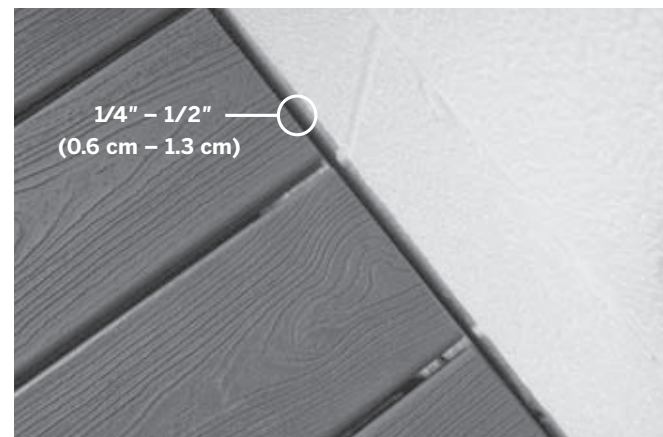

Abutting Solid Objects

When decking is abutting a wall, you must also gap it 1/4" - 1/2" (0.6 - 1.3 cm) depending on the temperature at installation. See chart at left.

STAIRS

Stairway Detail

- » Stair treads built with Trex® meet requirements by the major national building codes. Consult your local municipality for specific requirements.
- » Fasten stair treads continuously across at least four stringers.
- » See chart (at right) for center-to-center spacing of profiles.
- » Dress the sides of the stringers and risers with Trex fascia or trim for a finished look.
- » Most model building codes require the stair treads to be constructed under the following requirements:
 - › Stairways must be at least 36" (91.5 cm) wide
 - › Stair treads must be at least 11" (28 cm) deep*
- » Gapping between Trex boards on stair treads must be 1/4" - 3/8" (0.6 cm - 1 cm).
- » The overhang of the stair tread is not to exceed 1/2" (1.3 cm).

* 5" (12.7 cm) wide Contours® will require gapping at the riser to meet the 10" tread requirement with 3/4" - 1-1/4" (2 cm - 3.2 cm) nosing.

NOTE: Trex rails meet all major building codes for use as a guardrail system. Local municipalities may require a graspable handrail on stairways. Check with your local building code official for local requirements. See Trex ADA Handrail System on pages 72 - 75.

5" Wide Contours Stairs

- Option 1:** Using two deck boards.
 - a. 3/8" (1 cm) gap at riser and between each board.
- Option 2:** Using two deck boards.
 - a. 1/2" (1.3 cm) gap at riser and 1/4" (0.6 cm) gap between each board.
- Option 3:** Using a feature board—a ripped piece of Contours 1-1/8" (3 cm) from the edge.
 - a. Feature board should be installed with factory end side facing up.
 - b. There should be no gap at the riser.
 - c. Install as follows:
 - » Riser, full board, 1/4" (0.6 cm) gap, feature board, 1/4" (0.6 cm) gap, full board.
 - » Riser, feature board, 1/4" (0.6 cm) gap, full board, 1/4" (0.6 cm) gap, full board.

MAXIMUM SPACING ON CENTER OF JOIST

2" x 6" (5.1 x 15.2 cm), 1" (2.5 cm) Boards	12" (30.5 cm)
Brasilia, 5" Contours, and Escapes	9" (24 cm)

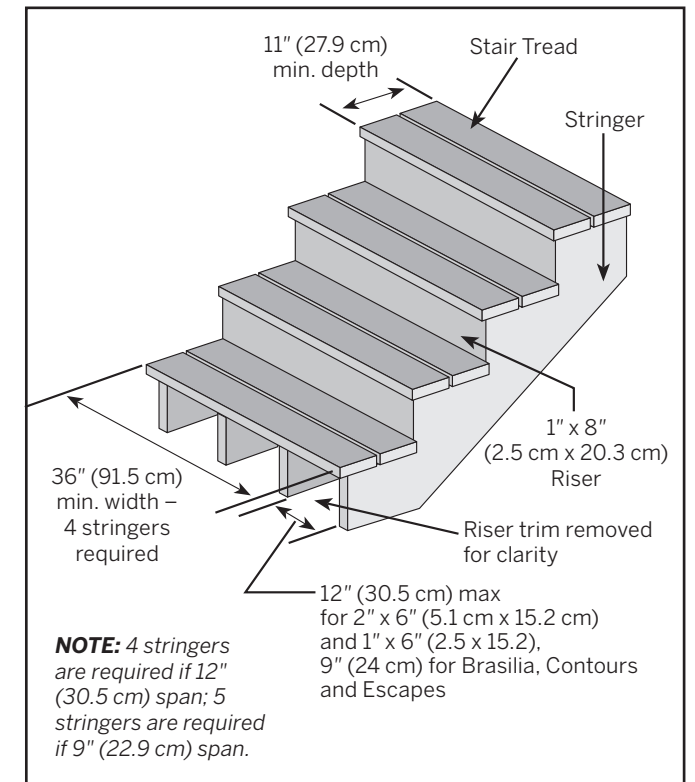

TIPS FOR INSTALLING A TREX® HIDEAWAY HIDDEN FASTENER SYSTEM

Installing Angled Deck Boards in Corners

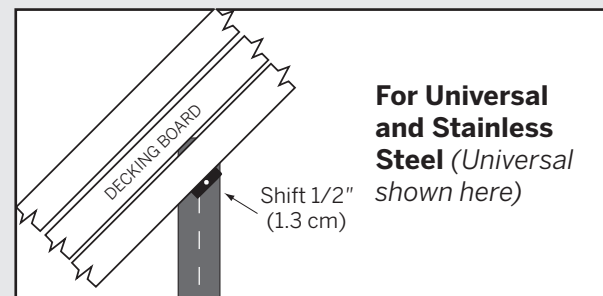

ALWAYS start in corner with a small triangular piece of decking at 45° and work outwards. Install Trex Hideaway fasteners 1/2" (1.3 cm) off center to keep fastener screws in middle of joists.

How to Butt Seams

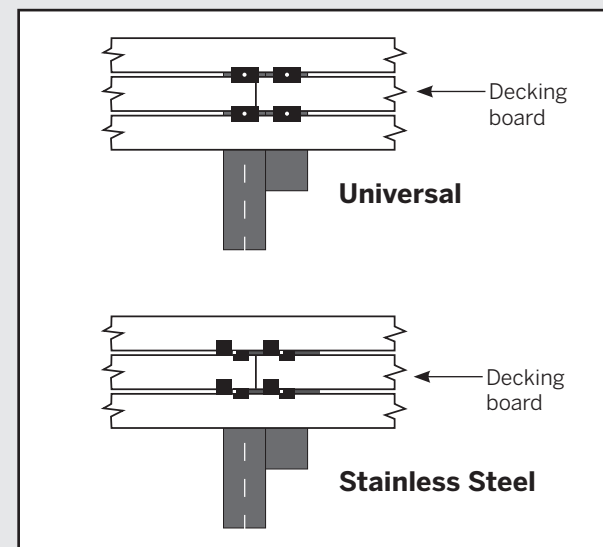

1. Install 10" - 12" (25.4 cm - 30.5 cm) framing boards along joists where seams will butt.
2. Place additional fasteners on the adjacent board over the joist and framing boards where the seam will be.
3. Put the first board of the seam in place and secure with fastener.
4. Butt end of second board to first and secure with fastener.

NOTE: Follow end-to-end gapping specifications on page 20.

5. Place second set of fasteners on each side of butt seam for next board.

Routing Grooves for Trex Hideaway Fasteners

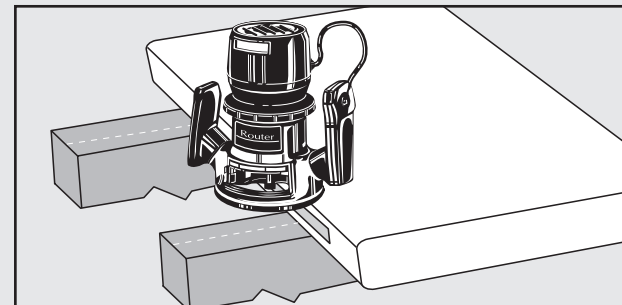

Using a Trex router bit/groove cutter available at your local Trex dealer:

1. Rout from bottom side of board.
2. Rout the entire length of the board, or at every intersection where the board is over support joists.



HOW TO INSTALL TREX HIDEAWAY® STAINLESS STEEL FASTENERS

PARTS

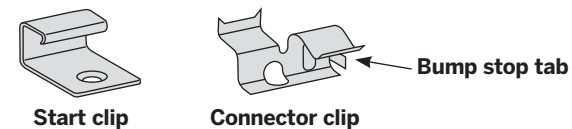

TOOLS NEEDED

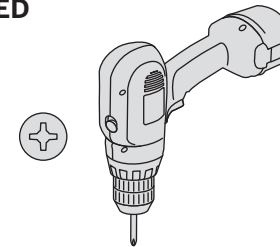

NOTE: Maximum spacing of deck boards using the Hideaway system is 16" (40.6 cm) on center. Fasteners provide 1/4" (0.6 cm) gap when installed correctly.

Installing Start Clips and First Board

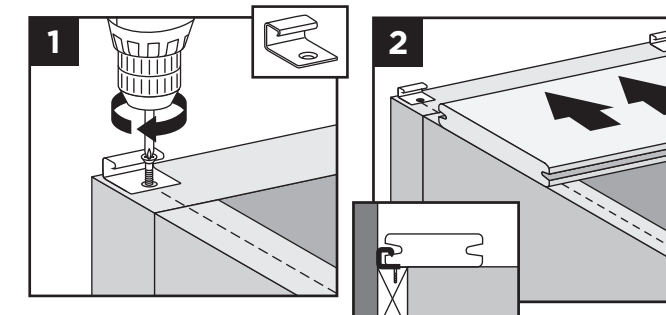

1. Install start clips on edge of ledger board, centered on each joist. Secure clips with screws.
2. Push grooved edge of deck board into start clips.
Important: First deck board **MUST** be straight and well secured.

Installing Stainless Steel Connector Clips

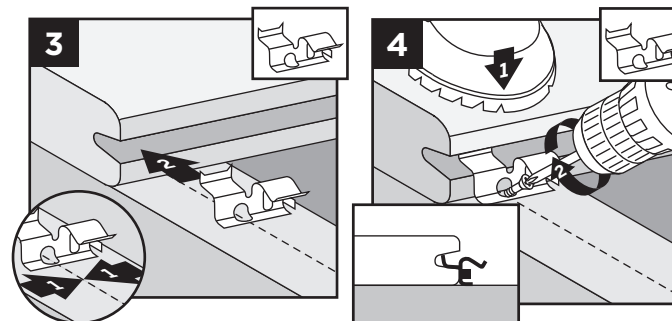

3. Insert connector clip into grooved edge of deck board.
4. Center connector clip on joist and secure with screw (provided) at 45° angle while standing on board and applying pressure to clip. Install one connector clip on each joist. **Connector clips MUST be vertical to deck boards with screws securing clips in board's grooved edge.**

Installing Second Board

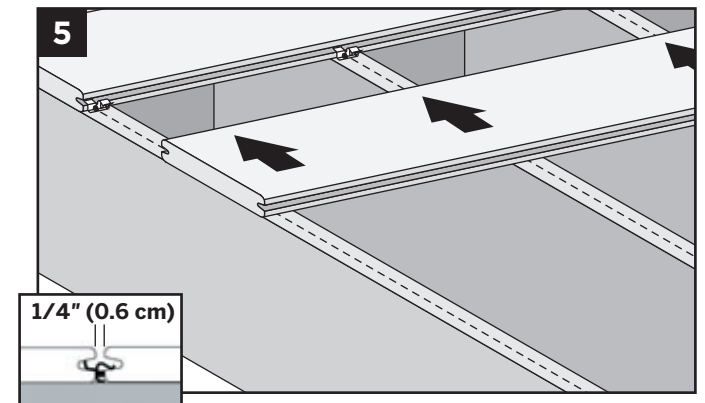

5. With next deck board in position and 2" (5.1 cm) from connector clips, push the boards with enough force to fully seat the clips in its grooved edge. Check gaps between boards. Fully engaged, the connector clip's bump stop tab provides a consistent 1/4" (0.6 cm) gap.

Installing the Last Board

Option 1: Using a Fascia Board

- 6a. Pre-drill pilot holes at an angle through grooved edge of deck board into ledger board. Install 2-1/2" (6.4 cm) decking screw using pilot holes to secure. Attach a fascia board flush with deck surface.

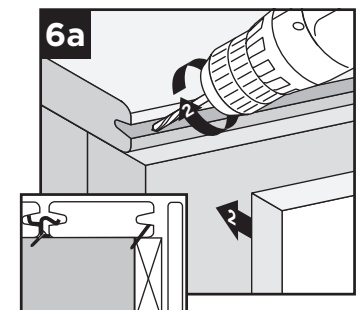

Option 2: With Deck Board Overhang

- 6b. Pre-drill pilot holes at 45° angle from below deck surface through rim joist. Seat last board into fasteners overhanging rim joist. Secure last board with 2-1/2" (6.4 cm) decking screws using pilot holes. Position fascia board below overhanging deck board.

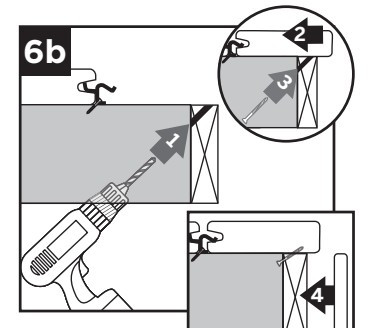

HOW TO INSTALL UNIVERSAL HIDDEN FASTENERS

NOTE: See page 25 for additional instructions if installing Escapes®.

PARTS

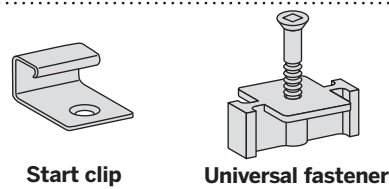

Start clip

Universal fastener

TOOLS NEEDED

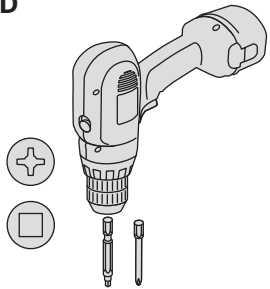

NOTE: Maximum spacing of deck boards using Hideaway system is 16" (40.6 cm) on center. Fasteners provide 1/4" (0.6 cm) gap when installed correctly.

Installing Start Clips and First Board

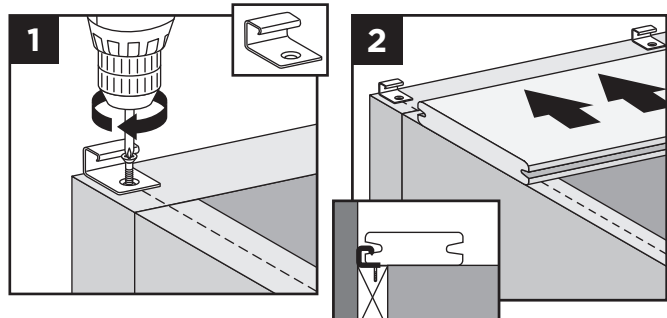

1. Install start clips on edge of ledger board, centered on each joist. Secure clips with screws.
2. Push grooved edge of deck board into start clips. **Important:** First board **MUST** be straight and well secured.

Install Universal Fasteners

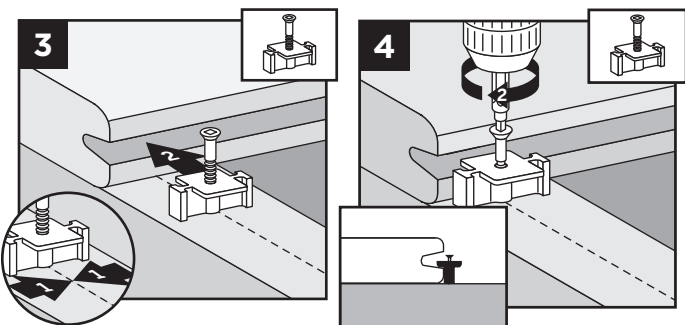

3. Insert fastener into grooved edge of deck board.
4. Align screw hole in fastener with center of joist. Continue along the length of the board at every joist.

NOTE: Screw only half way down. **DO NOT** fully tighten.

Installing Second Board

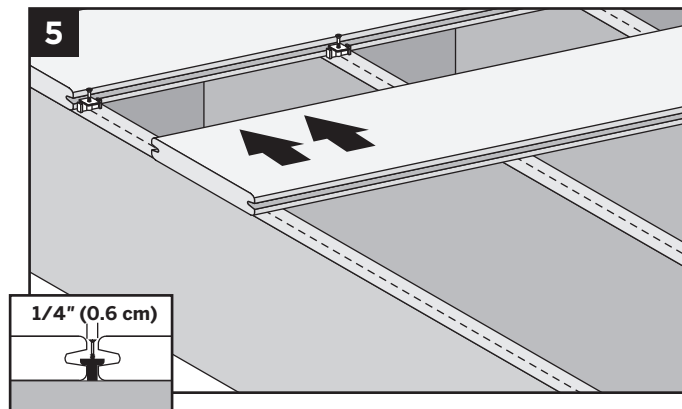

5. Slide second board into place, making sure fasteners fit into groove. Install the next universal fastener on the other side of the second board in the same manner as Steps 3 and 4. **DO NOT** fully tighten the screw.

Complete Installation

6. Tighten screws on fasteners in first row. Proceed with Steps 3 through 5, tightening down each row after board that follows is in place. Be sure to use a long #1 square bit.

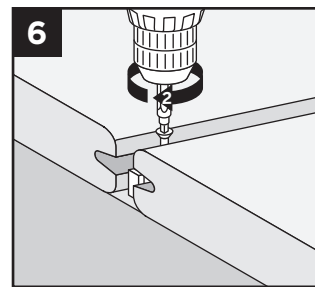

Installing Last Board

Option 1: Using Fascia Board

- 7a. Pre-drill pilot holes at an angle through grooved edge of deck board into ledger board. Install 2-1/2" (6.4 cm) screws through pilot holes to secure. Attach a fascia board flush with deck surface.

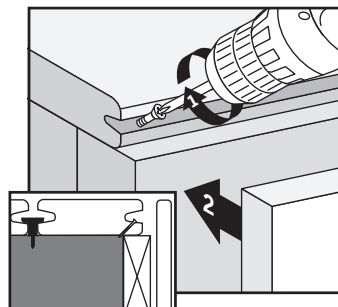

Option 2: With Deck Board Overhang

- 7b. Pre-drill pilot holes at 45° angle from below deck surface through rim joist. Seat last board into fasteners overhanging rim joist. Secure board with 2-1/2" (6.4 cm) screws using pilot holes. Position fascia board below overhanging deck board.

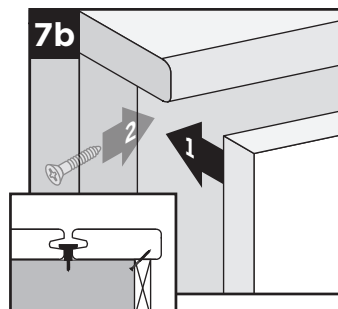

HOW TO INSTALL ESCAPES® BOARDS WITH TREX® UNIVERSAL FASTENERS

1. Follow steps 1 and 2 for installing start clips and first board. See page 24.
2. At both ends and center of first board, toenail screw (provided with Escapes universal hidden fasteners), at an angle through grooved edge of deck board.
3. Follow steps 3-5 for installing universal fasteners. See page 24.

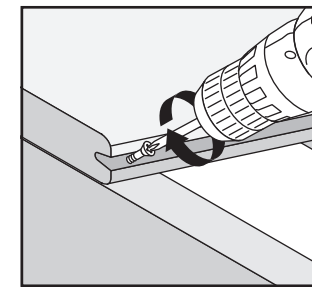

4. For every consecutive board installed, toenail screw at an angle through grooved edge of deckboard as stated in Step 2.
5. Follow remaining steps for completing installation and installing last board. See page 24.

HOW TO REPLACE TREX® BOARDS INSTALLED WITH STAINLESS STEEL OR UNIVERSAL FASTENERS

Stainless Steel Fasteners

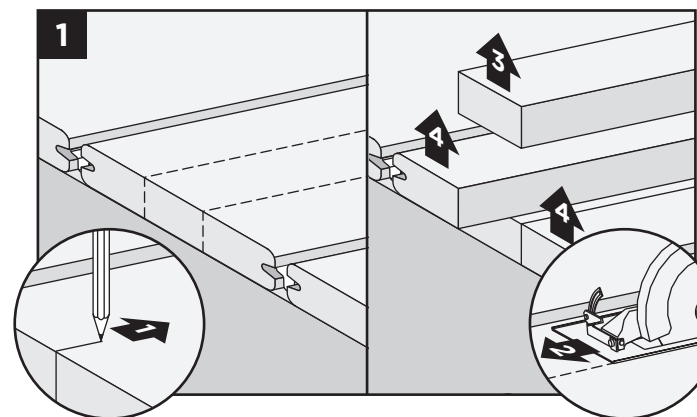

1. Mark the board to be replaced in thirds. Cut each side of middle section and remove it. Remove remaining two sections.

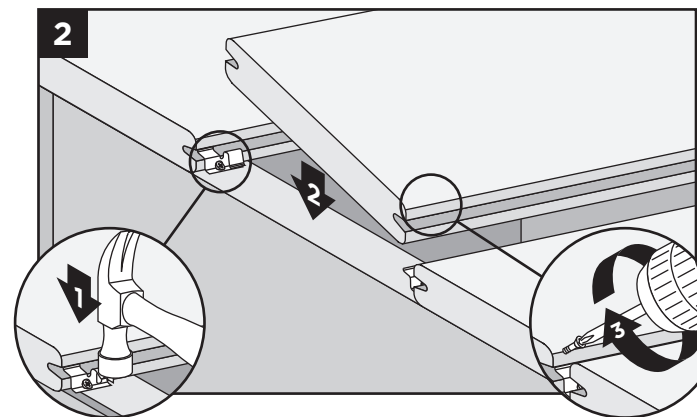

2. Hammer down the exposed side of the connector clips. Place the new board into position using a pry bar to maneuver it into place. Secure board on grooved edge with finish nails, screws or use counter drill, screws and plugs.

Universal Fasteners

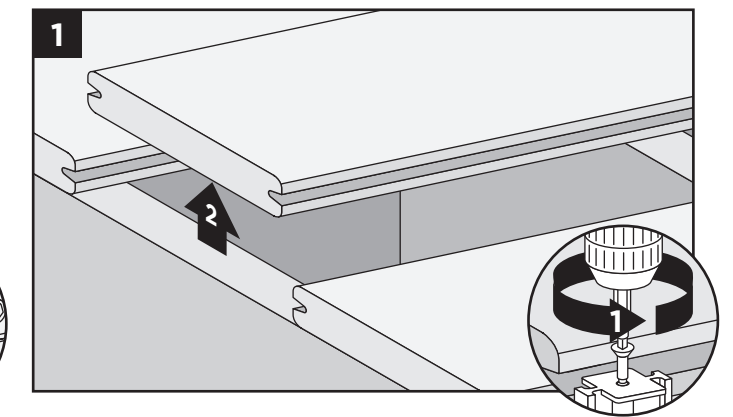

1. Remove screws from fasteners on both sides of board to be replaced and remove board.

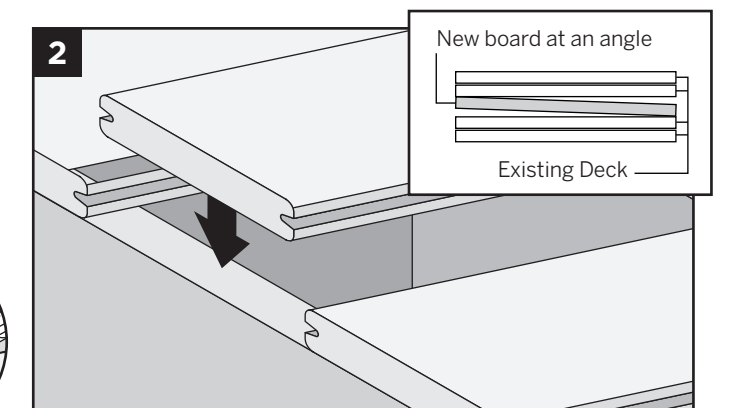

2. Angle new board to place. See inset box (above).

HOW TO REPLACE TREX® BOARDS INSTALLED WITH STAINLESS STEEL OR UNIVERSAL FASTENERS/CONTINUED

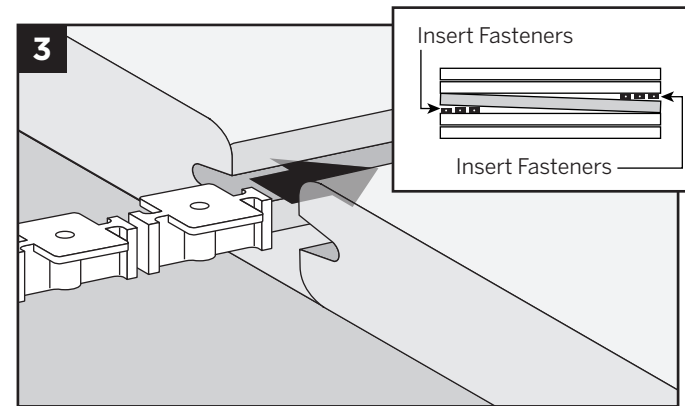

NOTE: You may have to loosen adjacent boards to slide fasteners into position.

4. Position replacement board and secure fasteners on center of each joist.

3. Slide a fastener for each joist into board grooves from both ends of the board.

HOW TO INSTALL STAIR TREADS

Installation Options

Option 1: Using Hidden Fastener System

1. Install start clips against riser on each step.
2. Install first board. *Follow steps on pages 23-24.*
3. Install second board. *Follow steps on pages 23-24.*
4. Secure with screws from top of second board into stringer boards.

Option 2: Using 2" x 4" (5.1 cm x 10.2 cm) Wood Support Blocks

1. Install start clips against riser on each stair tread.
2. Install first board. *Follow steps on pages 23-24.*
3. Attach 2" x 4" (5.1 cm x 10.2 cm) blocks between stringers.
4. Pre-drill holes up through blocks.
5. Install second board. *Follow steps on pages 23-24.*
6. Secure with screws from bottom through blocks and into stair treads.

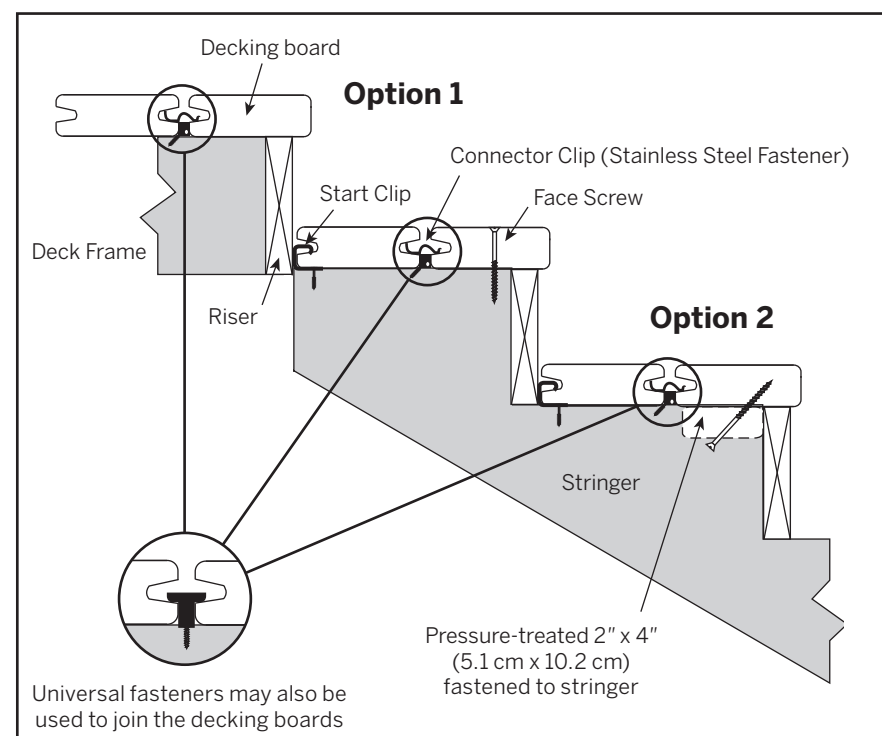

HOW TO INSTALL POST MOUNTS ON DECK BOARD

NOTE: Cannot be used with Trex Transcend® Classic railing or Trex Traditional railing styles.

PARTS

- » (1) Post mount
- » (2) Guide blocks
- » (4) 5/16" x 6" (0.8 cm x 15.2 cm) Hex (mounting) bolts
- » (4) 5/16" x 1" (0.8 cm x 2.5 cm) Hex (leveling) bolts
- » (1) Leveling plate
- » (1) Back plate
- » (8) Flat washers
- » (4) Hex nuts
- » (4) 3/4" (1.9 cm) Self-tapping screw
- » (8) 1-1/2" (3.8 cm) Stainless steel screws
- » (8) 2" (5.1 cm) Stainless steel screws

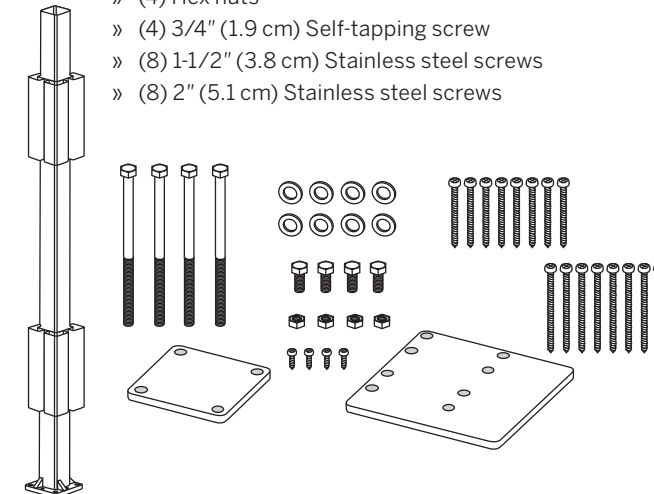

TOOLS NEEDED

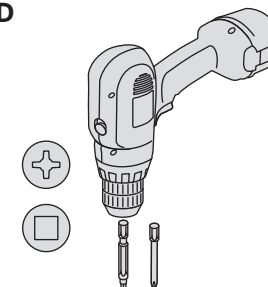

Install Blocking at Post Location

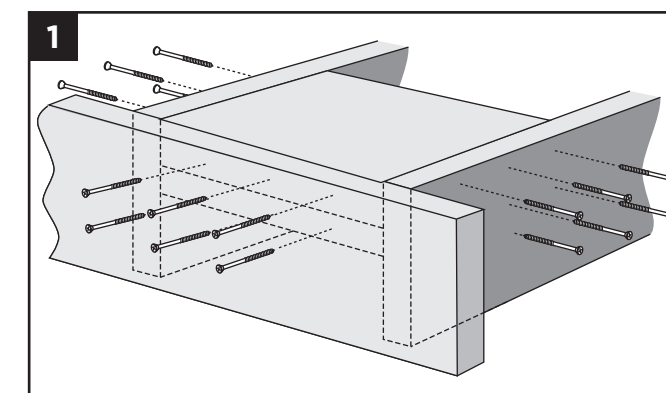

1. Install at least two 2" x 8" (5.1 cm x 20.3 cm) boards as blocking under post location. Securely attach blocking using wood screws, penetrating blocking a minimum of 1-1/2" (3.8 cm).

Position Leveling Plate

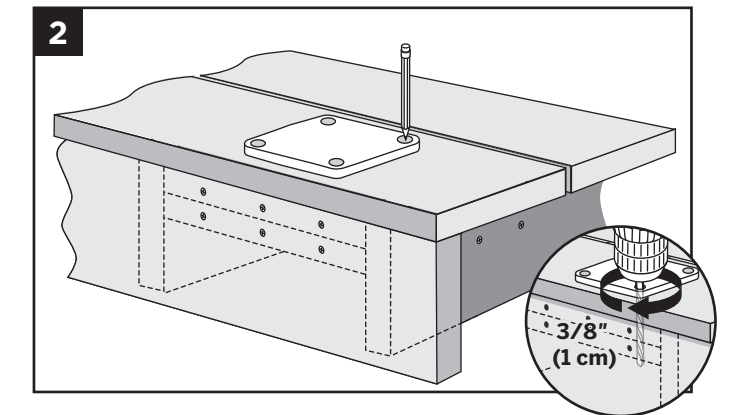

2. Using leveling plate as a template, mark locations of the four holes. Drill through decking and blocking using a 3/8" (1 cm) diameter drill bit.

Place and Level Post Mount

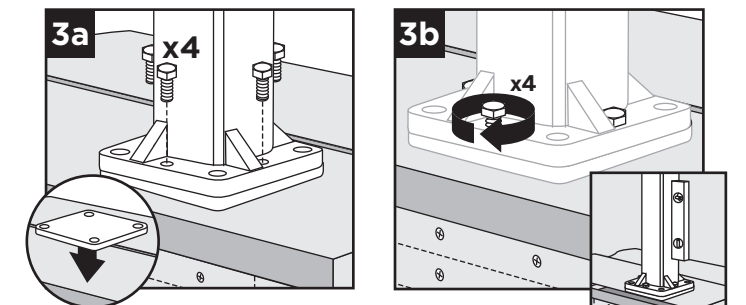

- 3a. Partially thread four 5/16" x 1" (0.8 cm x 2.5 cm) hex (leveling) bolts through center holes in post mount. Place leveling plate on decking surface with holes aligned.
- 3b. Place post mount on leveling plate and adjust 5/16" x 1" (0.8 cm x 2.5 cm) hex bolts to plumb.

Installing Mounting Bolts and Back Plate

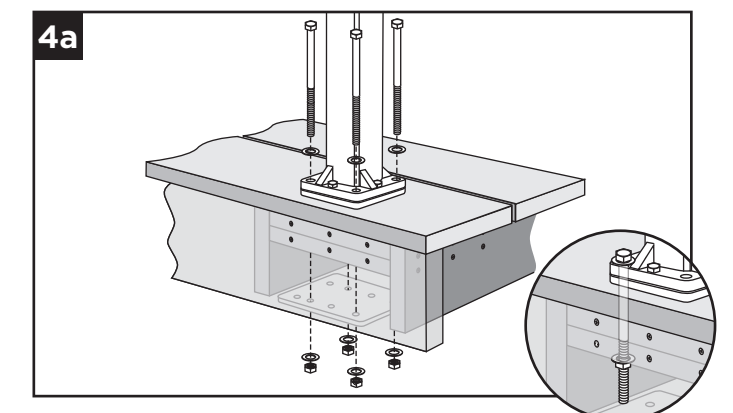

- 4a. Thread the 5/16" x 6" (0.8 cm x 15.2 cm) hex (mounting) bolts through the post mount, leveling plate, and blocking. Place back plate on underside with mounting bolts through appropriate holes and secure with washers and hex nuts.

HOW TO INSTALL POST MOUNTS ON DECK BOARDS/CONTINUED

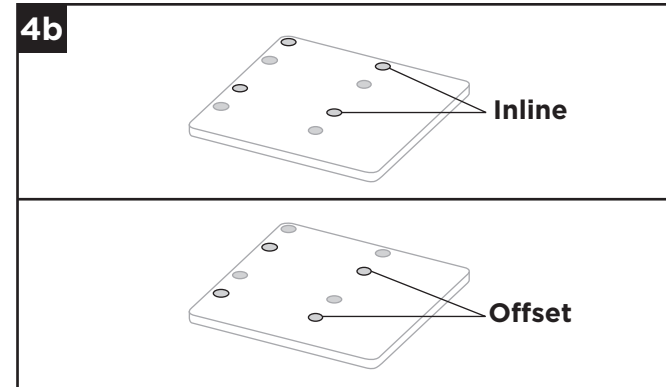

4b. Use center holes for inline applications and offset holes for corner applications.

Install Guide Blocks

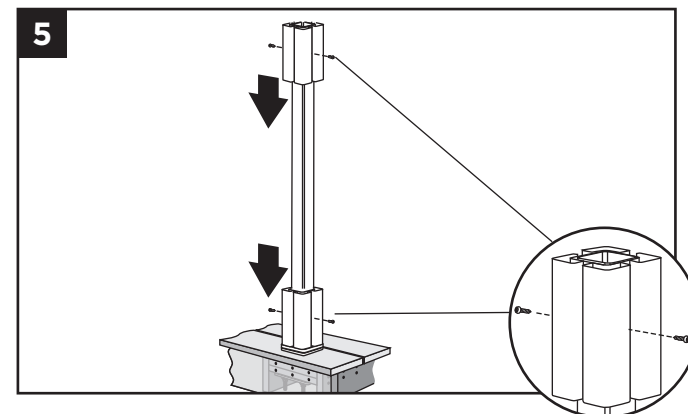

5. Place the two guide blocks onto post mount. Insert self-tapping screws (provided) to secure.

Install Railing System of Choice

- NOTE:** If installing a Trex® railing system:
- » Mark screw placement on post sleeve for the rail support brackets (RSBs).
 - » Pre-drill screw holes through post sleeve and aluminum guide blocks with a 1/8" (0.3 cm) drill bit.
 - » Attach RSBs using 1-1/2" (3.8 cm) screws (provided) for 4" x 4" (10.2 cm x 10.2 cm) Trex post sleeves.
 - » Attach RSBs using 2" (5.1 cm) screws (provided) for 6" x 6" (15.2 cm x 15.2 cm) Trex post sleeves.

DECKING: HOW TO INSTALL POST MOUNTS ON CONCRETE

NOTE: Cannot be used with Trex Transcend® Classic railing or Trex Traditional railing styles.

PARTS

- » (1) Post mount
- » (2) Guide blocks
- » (4) 3/8" x 3" (0.8 cm x 15.2 cm) Concrete bolts
- » (4) 5/16" x 1" (0.8 cm x 2.5 cm) Hex (leveling) bolts
- » (1) Leveling plate
- » (4) Flat washers
- » (4) 3/4" (1.9 cm) Self-tapping screw
- » (8) 1-1/2" (3.8 cm) Stainless steel screws
- » (8) 2" (5.1 cm) Stainless steel screws

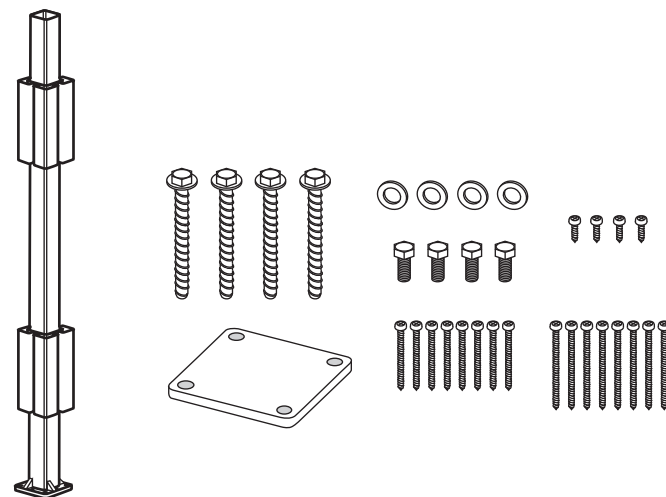

HOW TO INSTALL POST MOUNTS ON CONCRETE/CONTINUED

TOOLS NEEDED

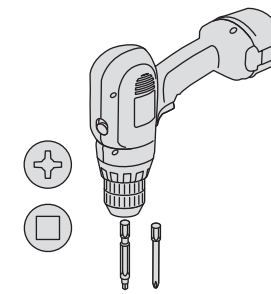

Position Leveling Plates

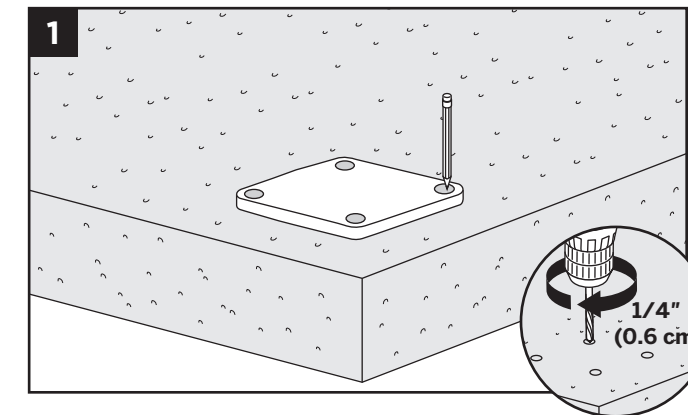

1. Using leveling plate as a template, mark locations of the four holes and drill into concrete at least 3-1/2" (8.9 cm) using a 1/4" (0.6 cm) masonry bit.

Install Leveling Bolts and Level Post Mount

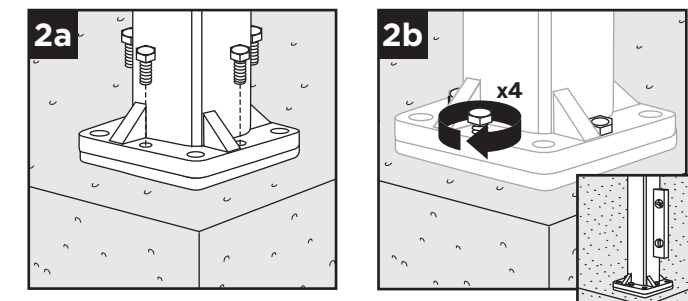

2a. Partially thread four 5/16" x 1" (0.8 cm x 2.5 cm) hex (leveling) bolts in post mount. Place leveling plate on concrete holes aligned.
2b. Place post mount on leveling plate and adjust 5/16" x 1" (0.8 cm x 2.5 cm) hex (leveling) bolts to plumb.

Install Mounting Bolts

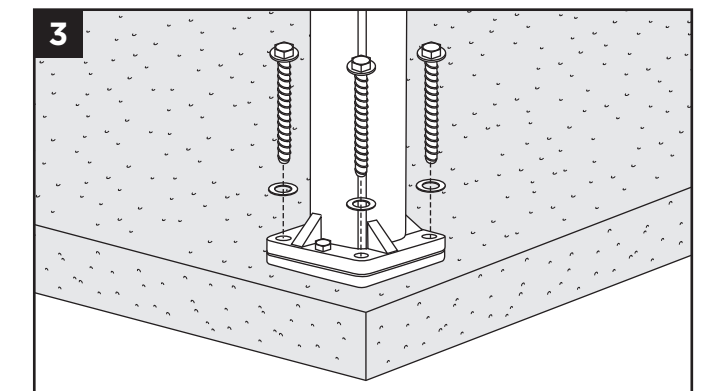

3. Secure post mount with four concrete bolts and washers.

NOTE: Torque recommended is 5 - 10 ft. lbs.

Install Guide Blocks

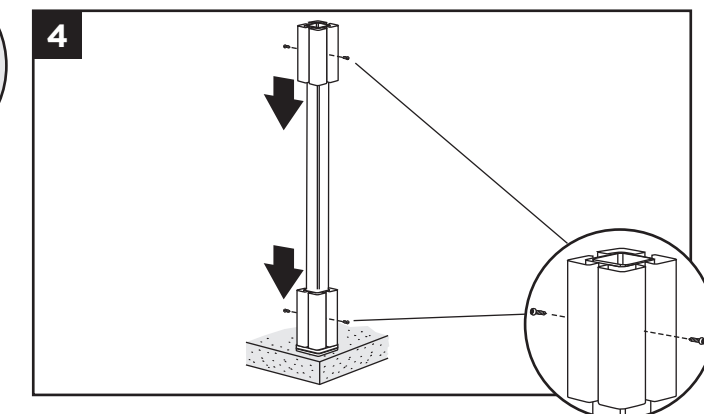



4. Place the two guide blocks on post mount and secure with self-tapping screws (provided).

Install Railing System of Choice



- NOTE:** If installing a Trex® railing system:
- » Mark screw placement on post sleeve for the rail support brackets (RSBs).
 - » Pre-drill screw holes through post sleeve and aluminum guide blocks with a 1/8" (0.3 cm) drill bit.
 - » Attach RSBs using 1-1/2" (3.8 cm) screws (provided) for 4" x 4" (10.2 cm x 10.2 cm) Trex post sleeves.
 - » Attach RSBs using 2" (5.1 cm) screws (provided) for 6" x 6" (15.2 cm x 15.2 cm) Trex post sleeves.

RAILING

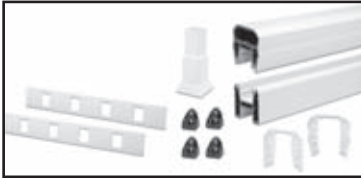
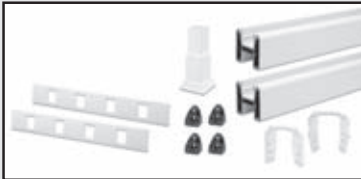
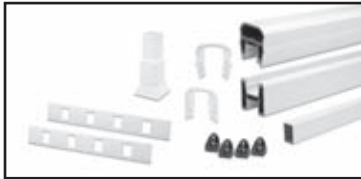

TREX TRANSCEND® RAILING SPECIFICATIONS AND PROFILES

PART	DESCRIPTION	ITEM NUMBER	COLORS	
Post Sleeve/ Porch Post/ Newel Post 	4" x 4" x 39" (10.2 cm x 10.2 cm x 99.1 cm) Post Sleeve 4" x 4" x 108" (10.2 cm x 10.2 cm x 2.74 m) Post Sleeve (Each 4" x 4" (10.2 cm x 10.2 cm) post sleeve includes a corrugated TrexExpress™ Railing Assembly Tool.)	XX040439APS XX0404108APS	WT, BK, TH, VL, GP, FP	
	4" x 4" x 48" (10.2 cm x 10.2 cm x 122 cm) Newel Post 4" x 4" x 108" (10.2 cm x 10.2 cm x 2.74 m) Porch Post 5" x 5" x 48" (12.7 cm x 12.7 cm x 2.74 m) Porch Post	WT040448NP WT0404108TPR WT0505108TPR	WT WT WT	
	6" x 6" x 39" (15.2 cm x 15.2 cm x 99.1 cm) 6" x 6" x 96" (15.2 cm x 15.2 cm x 243.8 cm) (Each 6" x 6" (15.2 cm x 15.2 cm) post sleeve fits over a 4" x 4" (10.2 cm x 10.2 cm) pressure-treated post.)	WT060639APS WT060696APS	WT WT	
	Post Mount	36" (91.4 cm) Post Surface Mount 42" (1.07 m) Post Surface Mount Post Surface Mount Hardware - Concrete (10 kits/box) Post Surface Mount Hardware - Wood (10 kits/box)	POSTMOUNT36 POSTMOUNT42 POSTHDWCONC POSTHDWWOOD	
	Post Sleeve Skirt/ Porch Post Skirt	4" x 4" (10.2 cm x 10.2 cm) Post Sleeve Skirt 4" x 4" (10.2 cm x 10.2 cm) Post Skirt (32/box) 5" x 5" (12.7 cm x 12.7 cm) Post Skirt (60/box) 6" x 6" (15.2 cm x 15.2 cm) Post Sleeve Skirt	XXSKIRT4X4 WTSQCAP4X4TPR WTSQCAP5X5TPR WTSKIRT6X6	WT, BK, TH, VL, GP, FP WT WT WT
Railings 	6' (1.83 m) Top and Bottom Rail Kit 8' (2.44 m) Top and Bottom Rail Kit 6' (1.83 m) Top and Bottom Stair Rail Kit 8' (2.44 m) Top and Bottom Stair Rail Kit	XX06HRK XX08HRK XX06SRK XX08SRK	WT, BK, TH, VL, GP, FP	
	6' (1.83 m) Universal Rail Kit 8' (2.44 m) Universal Rail Kit 6' (1.83 m) Universal Stair Rail Kit 8' (2.44 m) Universal Stair Rail Kit	XX06HURK XX08HURK XX06SURK XX08SURK		
	6' x 36" (1.83 m x 91.4 cm) Complete Rail Kit—Horizontal 6' x 36" (1.83 m x 91.4 cm) Complete Rail Kit—Stair 8' x 36" (2.44 m x 91.4 cm) Complete Rail Kit—Horizontal 8' x 36" (2.44 m x 91.4 cm) Complete Rail Kit—Stair	WT0636HRK WT0636SRK WT0836HRK WT0836SRK	WT WT WT WT	
	6' x 36" (1.83 m x 91.4 cm) Glass Panel Rail Kit	WT0636HPK	WT	
	91.5" (232.4 cm) Railing Top Cap [Actual length of 6' rail is 67.5' (1.71 m). Actual length of 8' rail is 91.5' (2.32 m).]	BKTOPCAP	BK	
	Balusters/Spindles	30" (76.2 cm) Square Baluster Kit (16/kit) 36" (91.4 cm) Square Baluster Kit (16/kit) 30" (76.2 cm) Colonial Spindle Kit (16/kit) 36" (91.4 cm) Colonial Spindle Kit (16/kit) 30" x 1" (76.2 cm x 2.5 cm) Architectural Baluster (5/kit) 36" x 1" (91.4 cm x 2.5 cm) Architectural Baluster (5/kit) Architectural Baluster Spacer—Level Architectural Baluster Spacer—Stairs 30" x 3/4" (76.2 cm x 1.9 cm) Contemporary Baluster Kit (10/kit) 36" x 3/4" (91.4 cm x 1.9 cm) Contemporary Baluster Kit (10/kit) Contemporary Baluster Spacer—Level Contemporary Baluster Spacer—Stairs	XX020230SBK XX020236SBK WT020230CSP WT020236CSP BK0130VBK BK0136VBK XXHVASPCR XXSVASPCR BK3Q30RBK BK3Q36RBK XXBALSPACER XXBALSPACESTR	WT, BK, TH, VL, GP, FP WT WT BK BK WT, BK, TH, VL, GP, FP BK BK WT, BK, TH, VL, GP, FP
	Post Sleeve Cap	Flat 4" x 4" (10.2 cm x 10.2 cm) Post Sleeve Cap Pyramid 4" x 4" (10.2 cm x 10.2 cm) Post Sleeve Cap Flat 6" x 6" (15.2 cm x 15.2 cm) Post Sleeve Cap Pyramid 6" x 6" (15.2 cm x 15.2 cm) Post Sleeve Cap	XXSQCAP4X4 XXPYCAP4X4 WTSQCAP6X6 WTPYCAP6X6	WT, BK, TH, VL, GP, FP WT WT WT

TREX TRANSCEND® RAILING SYSTEMS

RAILING SYSTEM	DESCRIPTION	ITEM NUMBER	COLORS
Top and Bottom Rail Kit <ul style="list-style-type: none"> Standard top rail Standard bottom rail Adjustable foot block Square hole baluster spacers Mounting hardware 	6' (1.83 m) Top and Bottom Rail Kit 8' (2.44 m) Top and Bottom Rail Kit 6' (1.83 m) Top and Bottom Stair Kit 8' (2.44 m) Top and Bottom Stair Kit	XX06HRK XX08HRK XX06SRK XX08SRK	BK, WT, TH, VL, GP, FP
Universal Top and Bottom Rail Kit <ul style="list-style-type: none"> Two standard bottom rails Adjustable foot block Square hole baluster spacers Mounting hardware 	6' (1.83 m) Universal Rail Kit 8' (2.44 m) Universal Rail Kit 6' (1.83 m) Universal Stair Kit 8' (2.44 m) Universal Stair Kit	XX06HURK XX08HURK XX06SURK XX08SURK	BK, WT, TH, VL, GP, FP
Complete Top and Bottom Rail Kit <ul style="list-style-type: none"> Standard top rail Standard bottom rail Baluster for foot block Square hole baluster spacers Balusters Mounting hardware 	6' x 36" (1.83 m x 91.4 cm) Complete Rail Kit - horizontal 6' x 42" (1.83 m x 106.7 cm) Complete Rail Kit - horizontal 6' x 36" (1.83 m x 91.4 cm) Complete Rail Kit - stair 6' x 42" (1.83 m x 106.7 cm) Complete Rail Kit - stair 8' x 36" (2.44 m x 91.4 cm) Complete Rail Kit - horizontal 8' x 42" (2.44 m x 106.7 cm) Complete Rail Kit - horizontal 8' x 36" (2.44 m x 91.4 cm) Complete Rail Kit - stair 8' x 42" (2.44 m x 106.7 cm) Complete Rail Kit - stair	WT0636HRK WT0642HRK WT0636SRK WT0642SRK WT0836HRK WT0842HRK WT0836SRK WT0842SRK	WT
Glass Panel Kit <ul style="list-style-type: none"> Standard top rail Standard bottom rail Mounting hardware Four-panel support moldings Two pieces weatherstrip Four 8" (20.3 cm) baluster spacers 	6' x 36" (1.83 m x 91.4 cm) Glass Panel Rail Kit NOTE: Tempered glass panels are not included in kit.	WT0636HPK	WT
System Component Parts	0° Railing Cut Kit 45° Gasket and RSB Adaptor Kit Stair Railing Cut Kit 0° Rail Connection Gaskets 22.5° Rail Connection Gaskets 45° Rail Connection Gaskets (for 6 x 6) Stair Rail Connection Gaskets	XXHCUT XX45RSBADAP XXSCUT XX00HGAS XX22HGAS WT45HGAS XX00SGAS	

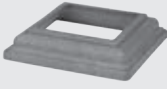
DESIGNER/TRADITIONAL RAILING SPECIFICATIONS AND PROFILES

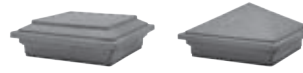
PART	DESCRIPTION	ITEM NUMBER	COLORS
Posts 	4" x 4" x 48" (10.2 cm x 10.2 cm x 121.9 cm) Post Sleeve 4" x 4" x 108" (10.2 cm x 10.2 cm x 274.3 cm) Post Sleeve <i>(TrexExpress™ template available for quick and accurate assembly)</i>	XX040448PS XX0404108PS	SD, WB, WG, MB
Post Sleeve Skirt 	4" x 4" (10.2 cm x 10.2 cm) Post Sleeve Skirt	XXRPSSKIRT	SD, WB, WG, MB
Railings 	6' (1.83 m) Top and Bottom Rail Kit* *Includes standard top and bottom rails, baluster for foot block, and mounting hardware. The 1" (2.5 cm) boards and 2" x 4" (5.1 cm x 10.2 cm) boards needed to accomplish the Traditional railing configuration are listed under "Decking", see page 15.	XX06HRK (Level and stair sections available.)	SD, WB, WG, MB
Balusters/Spindles 	30" (76.2 cm) Square Baluster Kit (16/kit) 36" (91.4 cm) Square Baluster Kit (16/kit) 144" (365.8 cm) Bulk Balusters 32" x 1" (81.3 cm x 2.5 cm) Architectural Baluster Kit (5/kit) 40" x 1" (101.6 cm x 2.5 cm) Architectural Baluster (5/kit) <i>(Only purchase these when constructing a Transcend or Traditional railing.)</i> 26" x 3/4" (66 cm x 1.9 cm) Contemporary Baluster Kit (10/kit) 32" x 3/4" (81.3 cm x 1.9 cm) Contemporary Baluster Kit (10/kit) 3/4" (1.9 cm) Contemporary Baluster Connector 3/4" (1.9 cm) Stair Contemporary Baluster Connector	XX020230SBK XX020236SBK XX020212BS210 BK0132VBK BK0140VBK BK3Q26RBK BK3Q32RBK BK075HCON BK075SCON	SD, WB, WG, MB
Post Sleeve Cap 	Flat Post Sleeve Cap Pyramid Post Sleeve Cap	XXRPSSQCAP XXRPSPYCAP	SD, WB, WG, MB
Designer Railing System	Top and Bottom Rail Kit <ul style="list-style-type: none"> Standard top rail Standard bottom rail Baluster for foot block Mounting hardware 	6' (1.83 m) Top and Bottom Rail Kit (Level and stair sections available.)	XX06HRK MB, SD, WB, WG
Designer System Component Parts	Designer Railing Cut Kit 72" (182.9 cm) Top Hand Rail Replacement Kit Designer Railing Sleeve TrexExpress™ Tool	DSRAILKIT XX06THRPL PSTOOL	MB, SD, WB, WG

ADA RAILING SPECIFICATIONS AND PROFILES

DESCRIPTION	ITEM NUMBER	COLORS
1 104" (264.2 cm) Straight rail 1.5" (3.8) diameter (PVC with aluminum stiffener)	BKADARAIL SDADARAIL WTADARAIL	Black Saddle White
2 Wall Return with Cover Plate (PVC with aluminum stiffener)	BKADA90WRK SDADA90WRK WTADA90WRK	Black Saddle White
3 Straight Wall Return (Cast iron)	BKADASWRK SDADASWRK WTADASWRK	Black Saddle White
4 Handrail Bracket with Screws and Cap (Cast Iron)	BKADARBK SDADARBK WTADARBK	Black Saddle White
5 90° Corner (PVC)	BK90CORN SD90CORN WT90CORN	Black Saddle White
6 End Loop (PVC with aluminum stiffener)	BKADALOOP SDADALOOP WTADALOOP	Black Saddle White
7 Post Return ("Candy Cane") (PVC with aluminum stiffener)	BKADARET SDADARET WTADARET	Black Saddle White
8 Straight Joiner (aluminum) <i>NOTE: Not visible.</i>	STRJOIN	

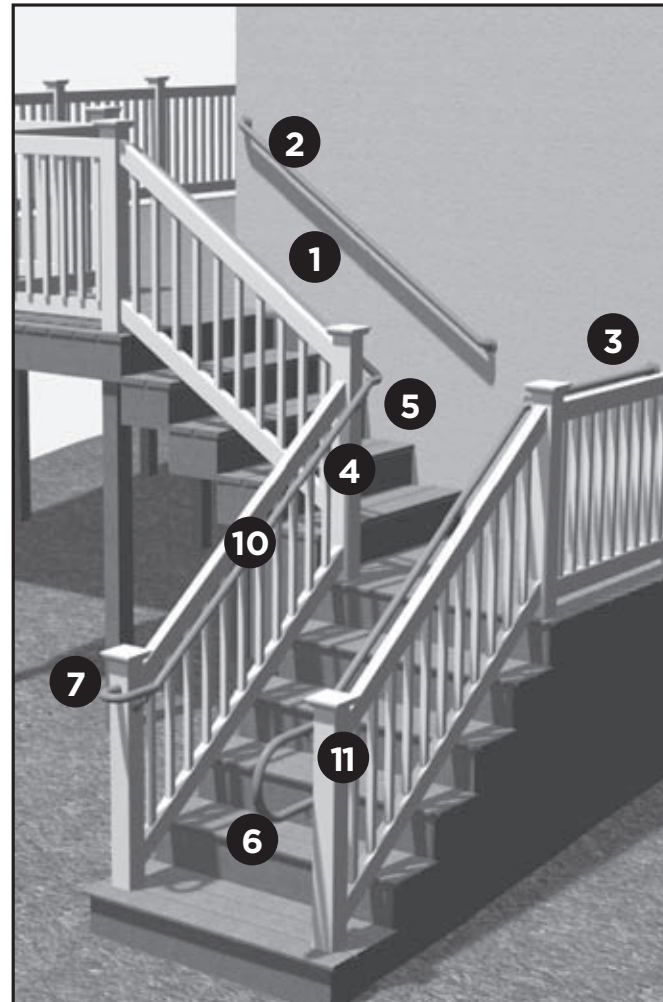

NOTE: No. 8 straight joiner and No. 9 adjustable joiner are not visible.

DESCRIPTION	ITEM NUMBER	COLORS
9 Adjustable Joiner (aluminum) <i>NOTE: Not visible.</i>	ADJOIN	
10 Joint Ring (plastic)	BKJOINRING SDJOINRING WTJOINRING	Black Saddle White
11 Rail End Cap (plastic)	BKADACAP SDADACAP WTADACAP	Black Saddle White

TREX TRANSCEND® RAILING

Trex Transcend® Railing Parts List

- A. Top rail
- B. Universal rail
- C. Trex railing support bracket (RSB)
- D. TrexExpress™ Railing Assembly Template*
- E. Rail gaskets
- F. Balusters
- G. Post sleeve cap*
- H. Post sleeve skirt*
- I. Post sleeve - 4" x 4" (10.2 cm x 10.2 cm) or 6" x 6" (15.2 cm x 15.2 cm) post sleeve**
- J. Trex decking
- K. TrexTrim™ or Trex fascia
- L. Code-approved wood joist - 2" x 8" (5.1 cm x 20.3 cm)
- M. Code-approved wood rim joist - 2" x 8" (5.1 cm x 20.3 cm) or larger
- N. Adjustable foot block
- O. Baluster spacer
- P. Top rail cap (optional component)

Trex Transcend® Glass Panel Parts List

- Q. Panel support molding
- R. Tempered glass panel*
- S. Trex panel support molding spacer
- T. Weatherstripping

* Item not included in the Transcend railing kits.
 ** Both 4" x 4" (10.2 cm x 10.2 cm) and 6" x 6" (15.2 cm x 15.2 cm) post sleeves are designed to fit over 4" x 4" pressure-treated post.

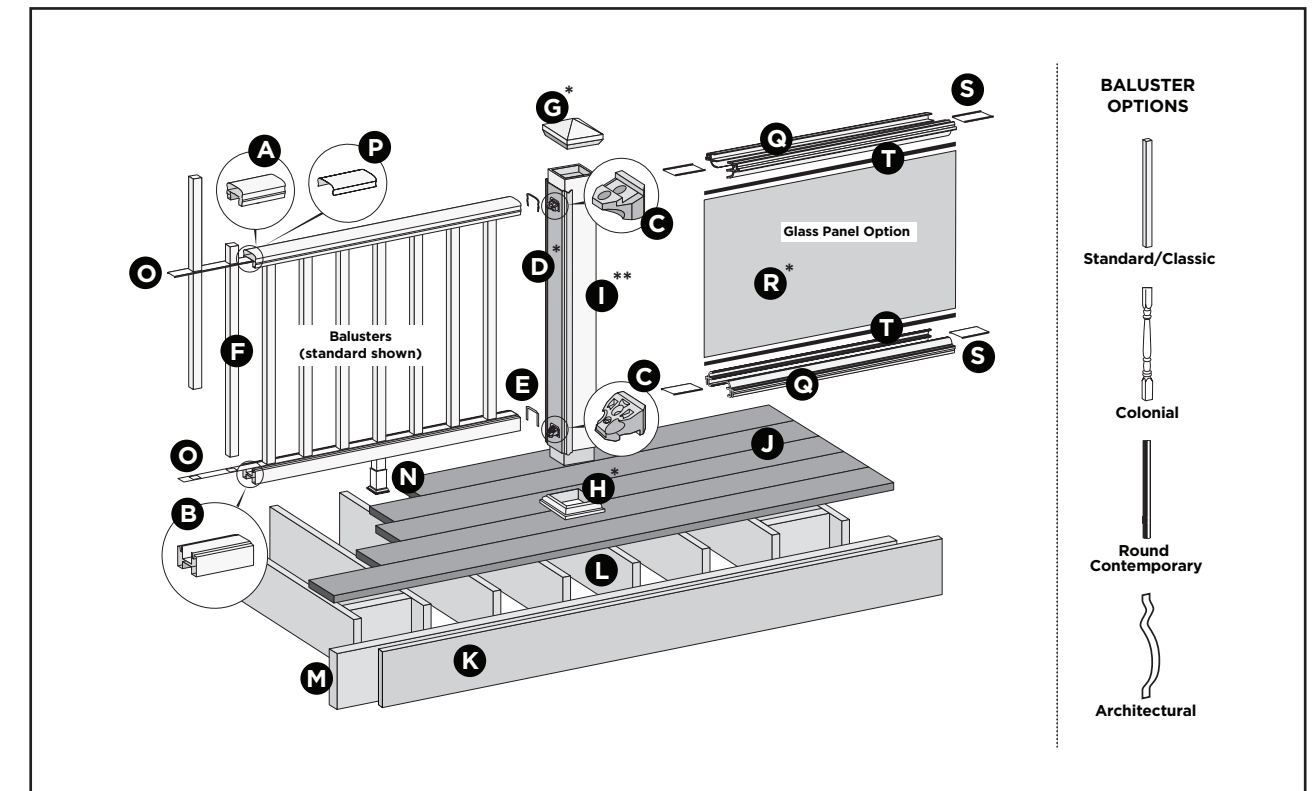

NOTE: Basic installation for balusters is the same for all options. When using Architectural or Round Contemporary balusters, use correct baluster spacers.

TREX TRANSCEND® DECK RAILING

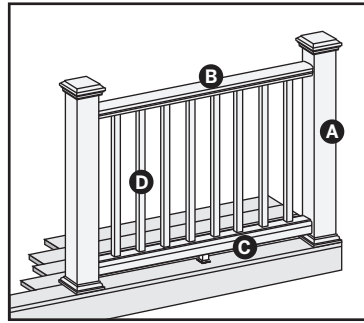

Standard

Cutting post sleeves is **NOT** required.

- A. Pressure-treated post with Trex Transcend post sleeve
- B. Top rail
- C. Universal bottom rail
- D. Trex standard balusters

See page 37 for "How to Install Standard Railing".

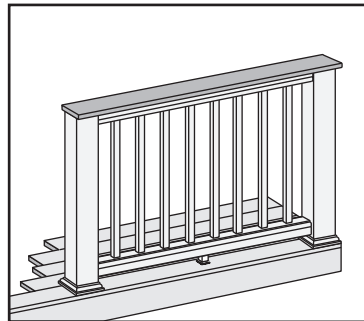

Classic

Post sleeves **WILL NEED TO BE CUT**.

- A. Pressure-treated post with Trex Transcend post sleeve
NOTE: » Only for use with 4" x 4" (10.2 cm x 10.2 cm) post sleeve.
» Trex Post Mounts (for decking or concrete) cannot be used with Transcend® Classic design.

- B. Deck board top rail. **NOTE:** 5" (12.7 cm) Contours and Escapes cannot be used.
- C. Universal top and bottom rail
- D. Trex standard balusters

See page 39 for "How to Install Classic Railing".

**POST
SLEEVES
WILL
NEED TO
BE CUT**

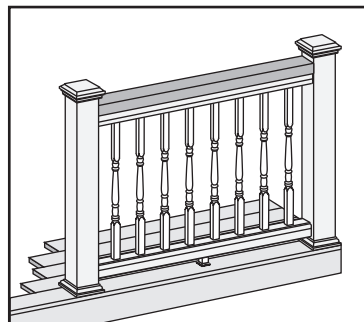

Colonial

Cutting post sleeves is **NOT** required.

- A. Pressure-treated post with Trex Transcend post sleeve
- B. 2" x 4" (5.1 cm x 10.2 cm) lateral top rail
- C. Universal top and bottom rail
- D. Trex colonial balusters

See page 40 for "How to Install Colonial Railing".

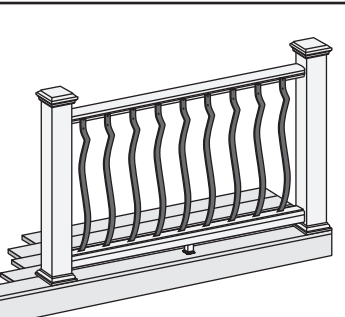
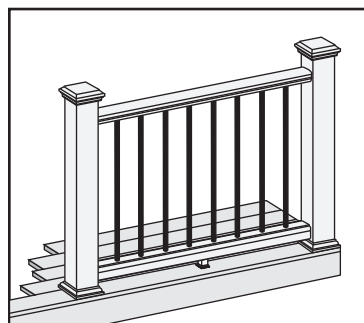

Contemporary/Architectural

Cutting post sleeves is **NOT** required. Follow instructions for standard Transcend installation, using metal balusters for square balusters.

- A. Pressure-treated post with Trex Transcend post sleeve
- B. Top rail
- C. Universal bottom rail
- D. Trex contemporary or architectural balusters

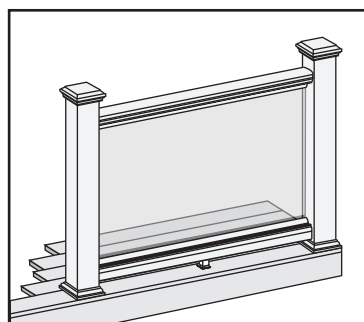

Glass Panel

Cutting post sleeves is **NOT** required.

- A. Pressure-treated post with Trex Transcend post sleeve
- B. Top rail
- C. Universal bottom rail
- D. Tempered glass panel (**NOT** included in kit)

See page 41 for "How to Install Glass Panel Railing".

HOW TO INSTALL STANDARD RAILING TREX TRANSCEND®

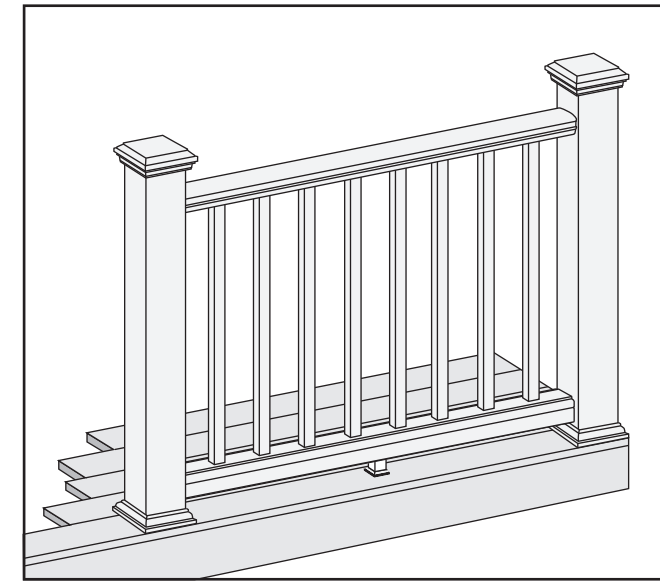

Read all instructions BEFORE installation.

Important: Post sleeves are **NOT** to be cut for this design style.

Installing Pressure-Treated Posts

- » Posts are to be installed 6' (1.83 m) or 8' (2.44 m) on center to accommodate appropriate railing length.
- » Attach posts using 1/2" (1.3 cm) carriage bolts.
- » Minimum joist size is 2" x 8" (5.1 cm x 20.3 cm).
- » Top bolts must be 1" (2.5 cm) from tops of joists.
- » Bottom bolts must be 5-1/8" (13 cm) from top bolts.

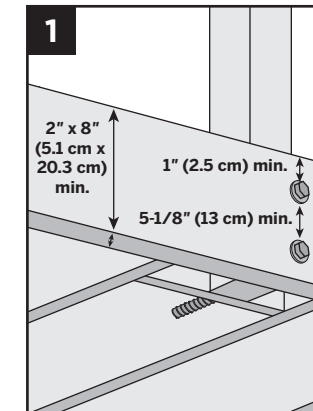

NOTE: Blocking can be added for extra strength.

Installing Post Sleeve Skirts and Post Sleeves

- 2. Slide post sleeve skirt over post and down to rest on decking surface. Slide post sleeve over post and position inside post sleeve skirt.

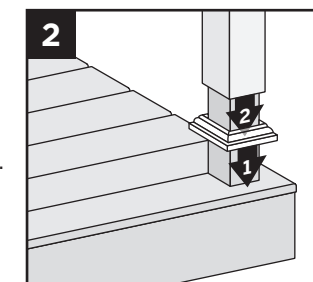

NOTE: Shims can be used to plumb post sleeves.

Installing Railing Support Brackets (RSBs)

Option 1: Without TrexExpress™ Railing Template

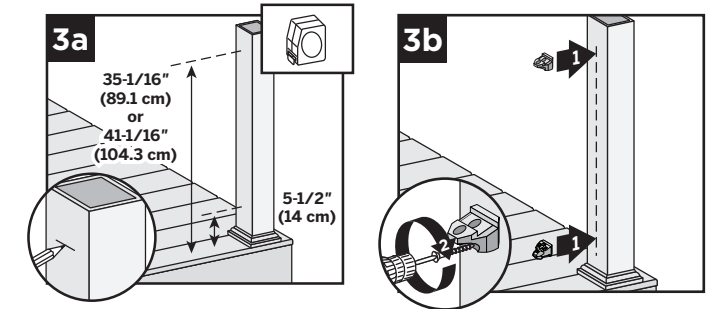

3a. Mark 5-1/2" (14 cm) and 35-1/16" (89.1 cm) from deck surface **OR** for 42" (106.7 cm) height, mark 5-1/2" (14 cm) and 41-1/16" (104.3 cm) from the deck surface.

3b. Place RSBs on marks, center on posts, and secure with 2" (5.1 cm) wood screws (provided with post sleeve). **Place top RSBs flat side UP, bottom RSBs flat side DOWN.**

Option 2: With TrexExpress™ Railing Template

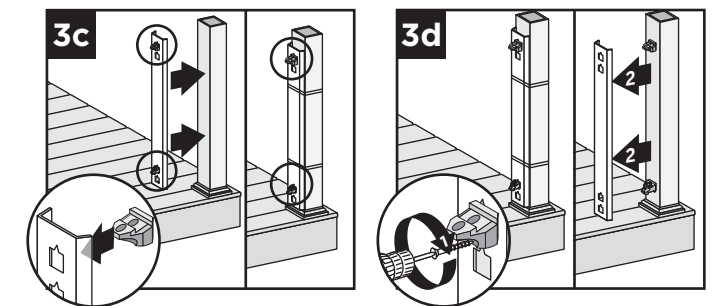

3c. Place RSBs in template. **Place top RSBs flat side UP, bottom RSBs flat side DOWN.** Secure template on post with tape or rubber band, with bottom of template resting on post skirt.

3d. Secure RSBs with 2" (5.1 cm) wood screws (provided with post sleeve) and remove template.

NOTE: Special steps are necessary when using 6" x 6" (15.2 cm x 15.2 cm) plastic TrexExpress™ template.

- » Cut off 1/2" (1.3 cm) from the bottom (blue arrows up) of the tool **BEFORE** first use.
- » Position top RSBs **ONLY**, 6" (15.2 cm) higher for 42" (106.7 cm) rail height.
- » Secure RSBs with 2-1/2" (6.4 cm) wood screws (provided in railing kit) and remove template.

HOW TO INSTALL STANDARD RAILING/CONTINUED TREX TRANSCEND®

Attaching Universal Rail and Foot Block

NOTE: Refer to page 47 for detailed instructions on installing foot blocks.

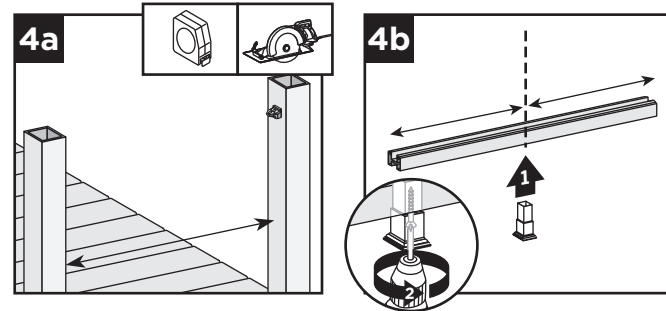

4a. Measure between posts and cut rails to same length.

NOTE: If using optional rail gaskets, subtract 1/16" (0.15 cm) from each end.

4b. Center foot block in universal rail channel and attach. **DO NOT** extend foot block.

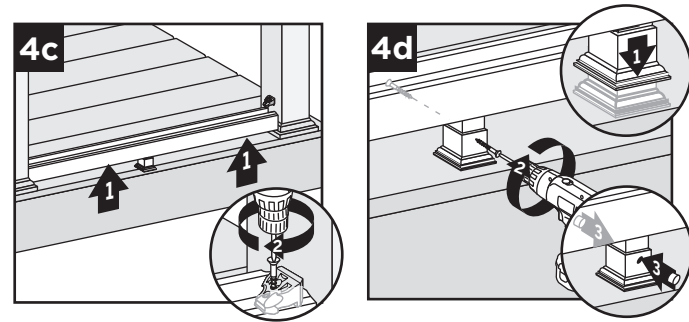

4c. Lift bottom rail so RSBs are in the channel and attach with self-tapping screws (provided).

4d. Telescope foot block down and screw through opposite sides. Place screw plugs.

Placing Baluster Spacers and Balusters

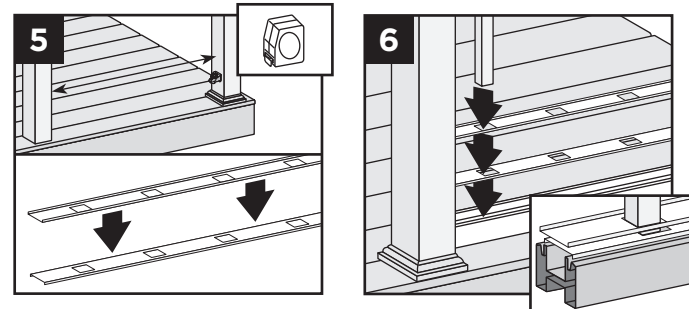

5. Cut baluster spacers the same length as rails, equally spaced so the holes line up.
6. Snap baluster spacer into bottom rail. Place inverted baluster spacer on top of first baluster spacer. Place balusters in baluster spacer holes.

Attaching Top Rail

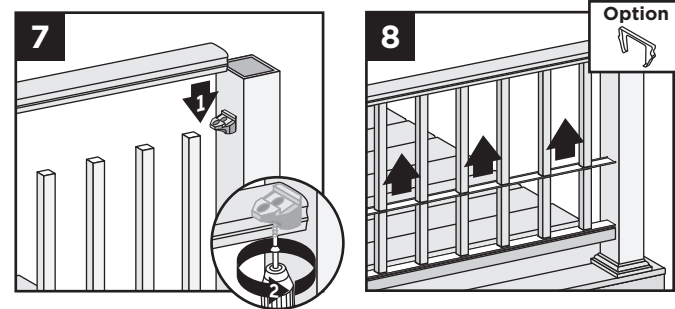

7. Place top rail on RSBs with balusters in rail channels. Attach top rail to RSB with two self-tapping screws (provided).
8. Slide baluster spacer up and snap into top rail. Place optional top rail gaskets on each end of rail.

Attaching Post Caps

9. Secure post caps with silicone or PVC adhesive.

NOTE: Clean-up any excess adhesive before drying.

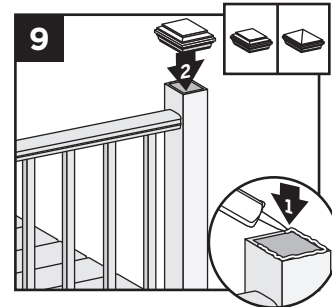

HOW TO INSTALL CLASSIC RAILING TREX TRANSCEND®

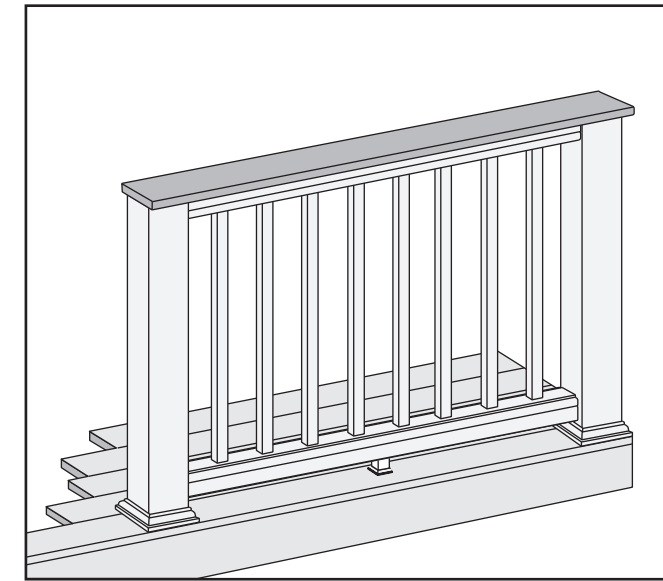

Important: ONLY for use with 4" x 4" (10.2 cm x 10.2 cm) post and post sleeve. Cutting post and post sleeve **ONLY** apply to the Classic style railing. Universal Railing Kit is required.

1. **Installing Pressure-Treated Posts**
See instructions on page 37.

Cutting Post and Post Sleeve

- 1a. Mark and cut post and post sleeve measuring from deck surface:
 - » 36-3/16" (91.9 cm) for 36" (91.4 cm) height.
 - » 42-3/16" (107.2 cm) for 42" (106.7 cm) height.

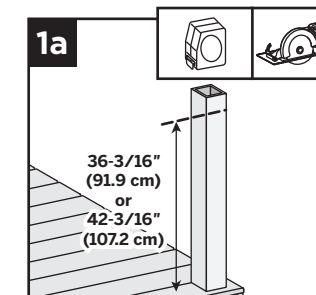

2. **Installing Post Sleeve Skirts and Post Sleeves** See instructions on page 37.
3. **Installing Railing Support Brackets (RSBs)** See instructions on page 37.
4. **Attaching Universal Rail and Foot Block** See instructions on page 38.
- 5-6. **Placing Baluster Spacers and Balusters** See instructions on page 38.

Attaching the Inverted Universal Rail

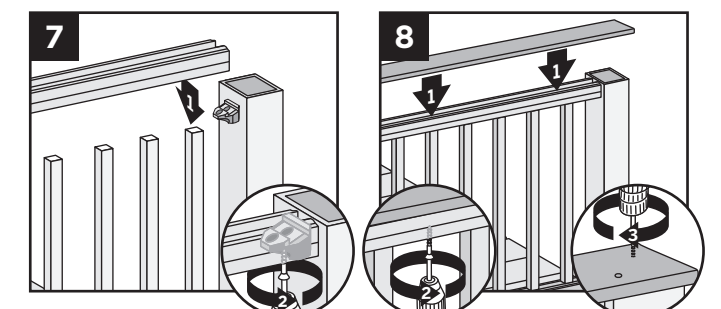

7. Place inverted universal rail onto RSBs with balusters in channel. Attach universal rail to RSBs with two self-tapping screws (provided).
8. Place deck boards (**DO NOT** use 5" (12.7 cm) *Contours* or *Escapes*) over universal rails. Attach boards on each post with Trex-recommended composite screws (see page 16) at a diagonal. Secure boards to universal rails with 2" (5.1 cm) pan-head screws (provided) every 16" (40.6 cm) on center.

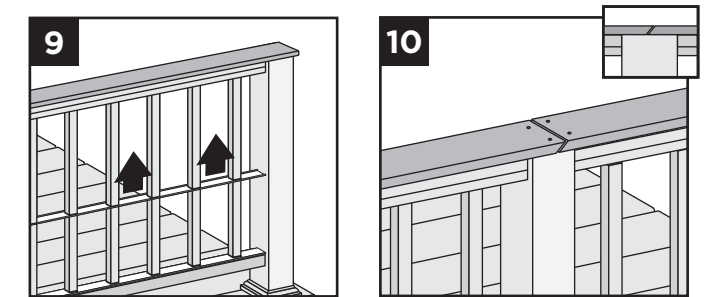

9. Slide baluster spacers up and snap into universal rails.

NOTE: If necessary, cut tips off rail gaskets prior to installation.

10. Use scarf cut for posts where two deck boards meet.

NOTE: If installing in weather below 40°F (4.5°C), leave 1/8" (0.3 cm) gap between deck boards.

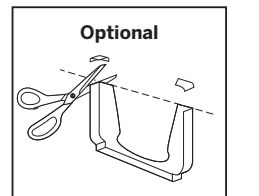

HOW TO INSTALL COLONIAL RAILING TREX TRANSCEND®

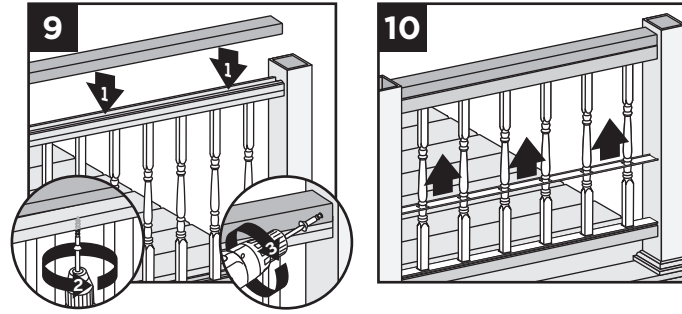
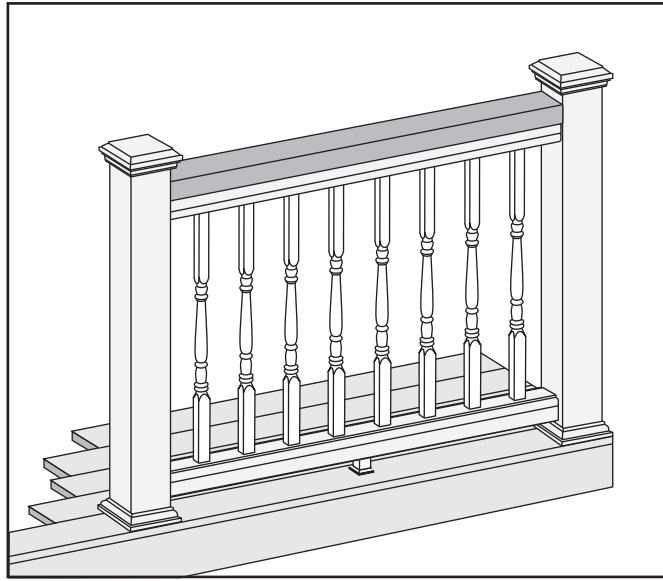

9. Place 2" x 4" (5.1 cm x 10.2 cm) on universal rail. Attach board to rail with 2" (5.1 cm) pan-head screws (provided) every 16" (40.6 cm) on center.

Toenail 2-1/2" (6.4 cm) screw at each end of 2" x 4" (5.1 cm x 10.2 cm) into post on back side of rail (side not facing decking).

10. Slide baluster spacer up and snap into universal rail.

NOTE: If necessary, cut tips off rail gaskets prior to installation.

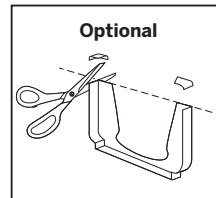

Attaching Post Caps

11. Secure post cap with silicone or PVC adhesive.

NOTE: Clean-up any excess adhesive before drying.

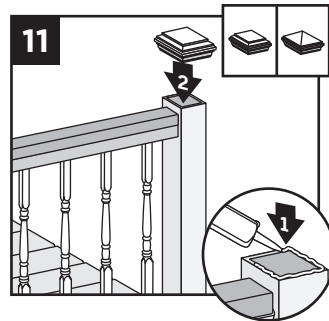

Important: Universal Railing Kit is required.

- Installing Pressure-Treated Posts**
See instructions on page 37.
- Installing Post Sleeve Skirts and Post Sleeves**
See instructions on page 37.
- Installing Railing Support Brackets (RSBs)**
See instructions on page 37.
- Attaching Universal Rail and Foot Block**
See instructions on page 38.
- 5-6. **Placing Baluster Spacers and Balusters**
See instructions on page 38.

Attaching Inverted Universal Rail

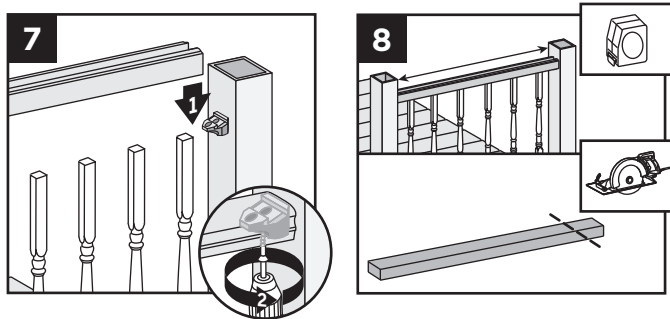

7. Place inverted universal rail onto RSBs with balusters in channel. Attach universal rail with two self-tapping screws (provided).
8. Measure between posts and cut 2" x 4" (5.1 cm x 10.2 cm) to length.

HOW TO INSTALL GLASS PANEL RAILING TREX TRANSCEND®

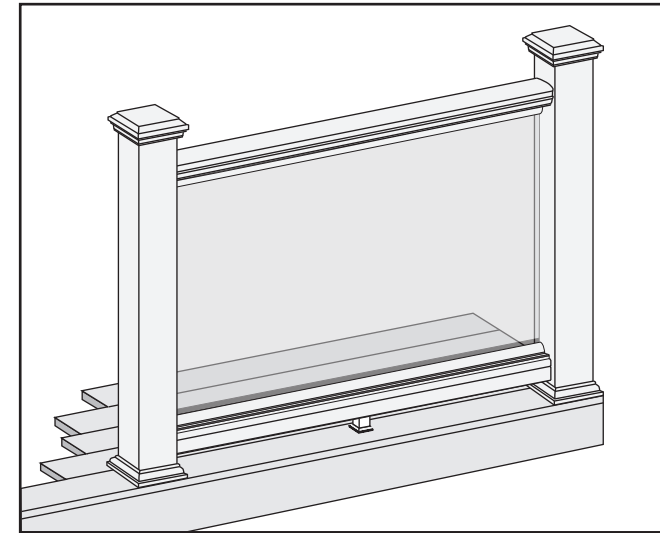

Read all instructions BEFORE installation.

- » You must purchase the 1/4" (0.6 cm) tempered glass panels. See dimensions below.
- » Glass panels **ONLY** for use with maximum 6' (1.83 m) on center post spacing.

TEMPERED GLASS PANEL DIMENSIONS

- » **36" (91.4 cm) high rail:**
1/4" x 30" x 62-1/2" max.
(0.6 cm x 76.2 cm x 158.8 cm)
- » **42" (106.7 cm) high rail:**
1/4" x 36" x 62-1/2" max.
(0.6 cm x 91.4 cm x 158.8 cm)

- Installing Pressure-Treated Posts**
See instructions on page 37.
- Installing Post Sleeve Skirts and Post Sleeves**
See instructions on page 37.
- Installing Railing Support Brackets (RSBs)**
See instructions on page 37.
- Attaching Universal Rail and Foot Block**
See instructions on page 38.

Attach Weatherstripping and Positioning Panel

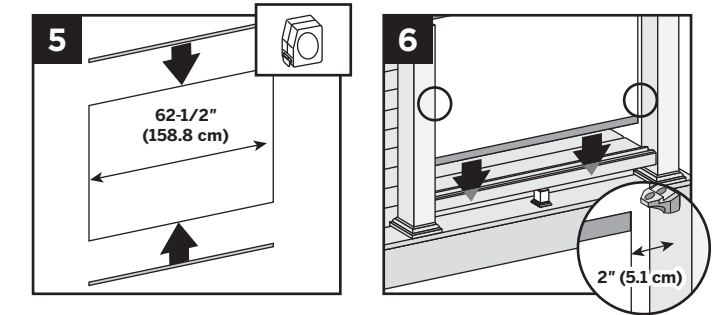

5. Push black-edged trim onto upper and lower edges of panel. Be sure trim runs entire length of glass. Extra trim can be cut with razor blade or scissors.
6. Position panel with weatherstripping into lower rail channel. Center panel between posts with about 2" (5.1 cm) of air space on each side of panel.

Attaching Top Rail and Panel Support Molding

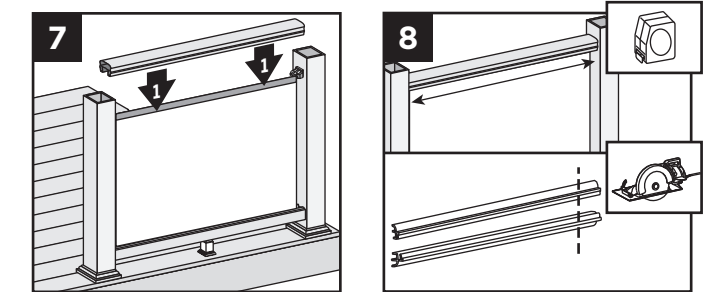

7. Place top rail over RSB brackets and glass panel. Secure rail to RSBs with 1-1/2" (3.8 cm) self-drilling screws (provided).

NOTE: Avoid hitting glass panel while using the drill.

8. Cut four panel support moldings (PSM) to same length as glass, 62-1/2" (158.8 cm). Cut slowly and one at a time, to avoid chipping.
9. Push PSM into rail to complete snap connection. (Lower rail PSM edge rests on top of rail. Top rail PSM snaps flush into rail.)

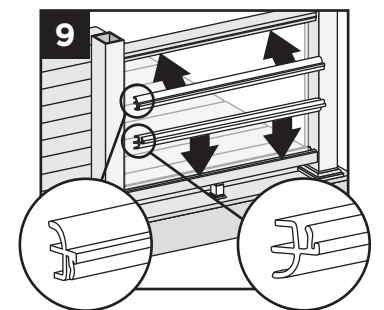

HOW TO INSTALL GLASS PANEL RAILING/CONTINUED TREX TRANSCEND®

Hiding Brackets

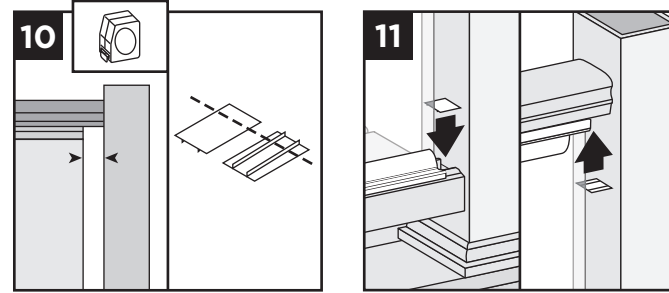

10. Cut Transcend baluster spacer into four lengths equal to distance between the glass panel and posts. Cut slowly and one at a time, to avoid chipping.
11. Snap spacer into bottom and top rail to hide brackets and create a seamless look.

Attaching Post Caps

12. Secure post caps with silicone or PVC adhesive.

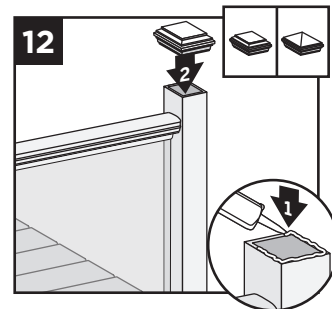

NOTE: Clean-up any excess adhesive before drying.

HOW TO INSTALL ON-AN-ANGLE RAILING TREX TRANSCEND®

NOTE: Transcend brackets are designed to be installed up to a 45° angle.

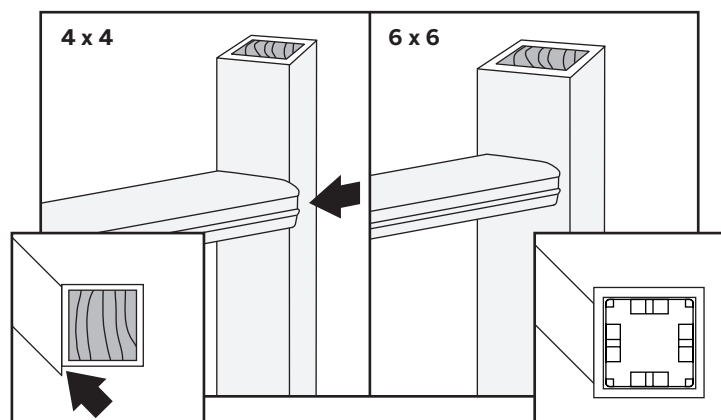

- » **Small angles** (1° - 30°). Both 4" x 4" (10.2 cm x 10.2 cm) or 6" x 6" (15.2 cm x 15.2 cm) post sleeves work well.
- » **Large angles** (31° - 45°). **USE ONLY** 6" x 6" (15.2 cm x 15.2 cm) post sleeves when installing on flat side.

» **45° angles** using 4" x 4" (10.2 cm x 10.2 cm) post sleeves **MUST** use Transcend bird's mouth brackets.

NOTE: Railing will be installed on corner of posts.

» Using 6" x 6" (15.2 cm x 15.2 cm) post sleeves at 45° angles. Brackets are installed off-center and use 45° Transcend brackets.

HOW TO INSTALL BIRD'S MOUTH RAILING TREX TRANSCEND®

NOTE: Use with 4" x 4" (10.2 cm x 10.2 cm) post sleeve **ONLY**.

Read all instructions BEFORE installation.

PARTS

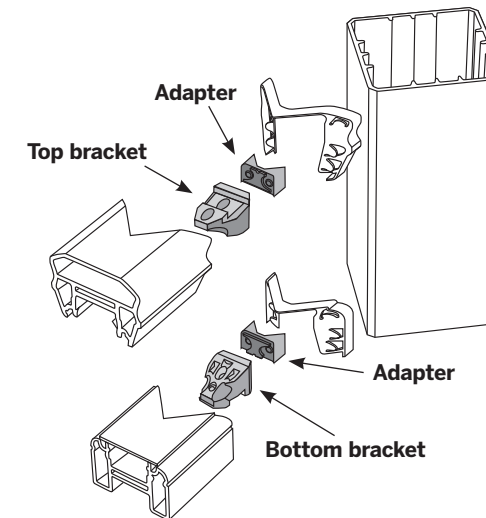

Mark Posts

1. Measure and mark 4" (10.2 cm) and 33-9/16" (85.2 cm) up from top of post skirt. For a 42" (106.7 cm) rail, top mark is 39-9/16" (100.5 cm) on post.

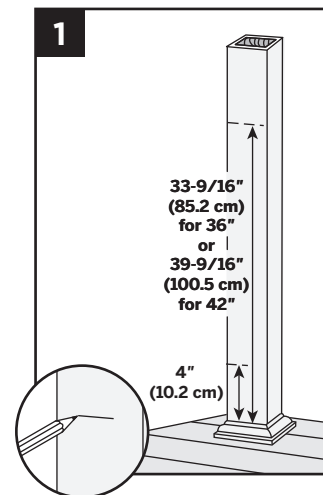

NOTE: Without skirt, add 1-1/2" (3.8 cm) to measurements.

Attaching Adapters

Snap adapters into RSBs.

Pre-drill Bottom and Top RSBs

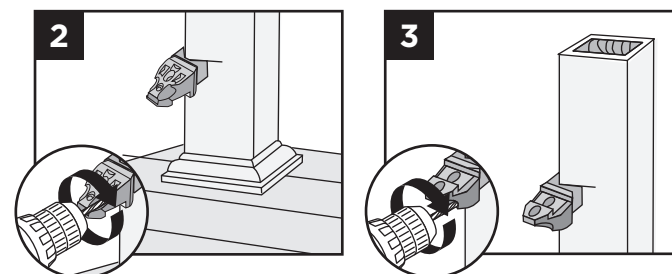

2. Position RSBs with adapter (**flat side DOWN**) for lower rail, mark and pre-drill screw holes with 1/8" (0.3 cm) drill bit on post.
3. Position RSBs with adapter (**flat side UP**) for top

rail, mark and pre-drill screw holes with 1/8" (0.3 cm) drill bit on post.

NOTE: Drill at slight inward angle to drill holes on marks.

Attaching Top and Bottom RSBs

4. Attach RSBs with adapters to posts with wood screws (provided).

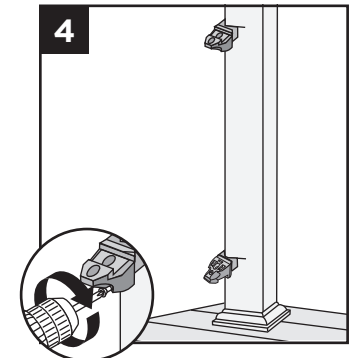

Measuring Rails

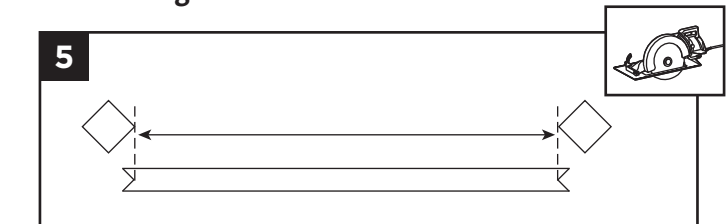

5. Measure from corner-to-corner between posts.

NOTE: Subtract 1/16" (0.15 cm) from each end to accommodate rail gaskets.

Cutting Rails

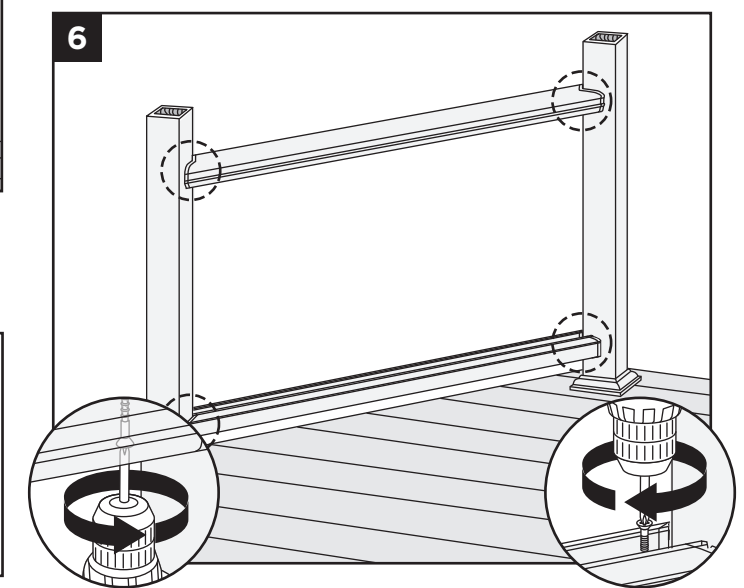

6. Mark 45° cuts on rails with template on assembly tool. Center of "V"s is the distance from corner-to-corner for posts. Cut rails to size and attach with self-tapping screws (provided).

HOW TO INSTALL BIRD'S MOUTH RAILING/CONTINUED TREX TRANSCEND®

Using Miter Box Saw to Cut Rails

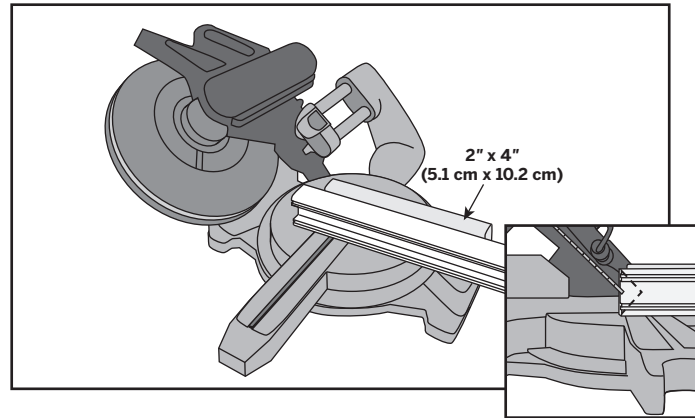

1. Place 2" x 4" (5.1 cm x 10.2 cm) on edge behind the rail to allow for complete cut.
2. Angle blade to 45°.

3. Set stop on saw so blade travels half the depth of rails. Several test cuts can be made on scrap material to accurately set the stop.
4. "V" cut both sides of the rail.

NOTE: Transcend's top and universal rails will require different stop settings.

HOW TO INSTALL TOP RAIL CAPS TREX TRANSCEND®

NOTE: Rail caps are used with Standard Design Transcend Railing **ONLY**.

Measuring and Cutting Top Rail Caps

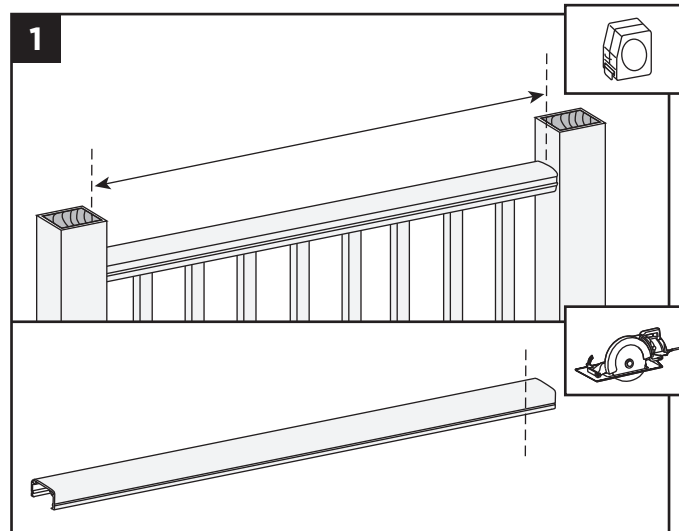

1. Measure distance between posts and mark rail caps. Cut caps to size and angle.

NOTE: » To avoid chipping, cut slowly.
» **DO NOT** use gaskets on top rail ends.

Apply Adhesive to Top Rails

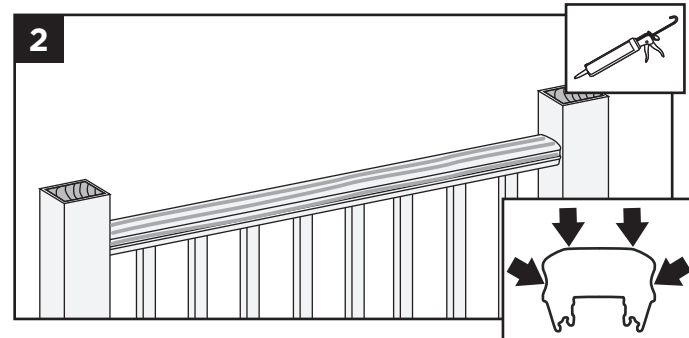

2. Apply heavy-duty construction adhesive to top rails in two profile lines on top and sides of rails.

Securing Top Rail Caps

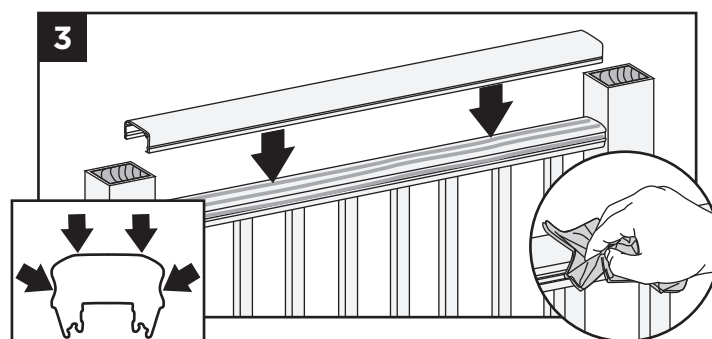

3. Seat rail caps firmly over top rails and adhesive. Clean off any excess adhesive on caps and top rails.

HOW TO INSTALL STAIR RAILING TREX TRANSCEND®

Read all instructions **BEFORE** installation.

NOTE: Transcend stair kits and gaskets work **ONLY WITH STAIR SLOPES OF 32°-37°**.

Installing Posts, Post Sleeve Skirts, and Post Sleeves for Stair Rails

1. Install posts, post sleeve skirts, and post sleeves according to standard Transcend railing instructions. See page 37.
 - » In most cases, a post and post sleeve longer than 39" (99.1 cm) will be needed on the lower section of stair rail to accommodate stair angle.
 - » Make sure top and bottom posts for stairs are installed at nose of each tread.

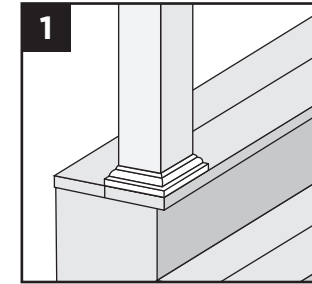

Positioning RSBs on BOTTOM Post

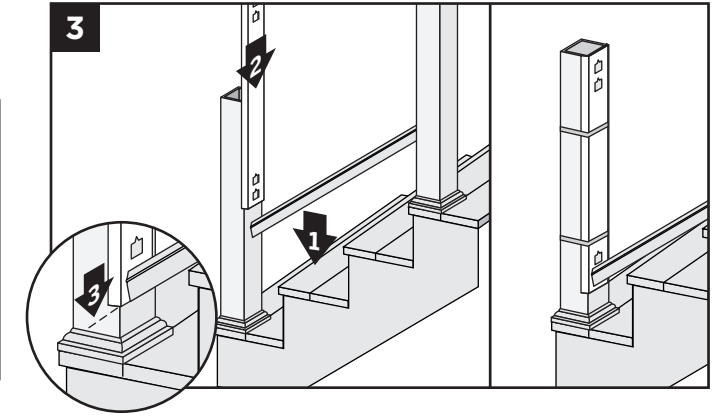

3. Position bottom rail between posts and slide TrexExpress™ Railing Assembly template into position with bottom rail outline on template aligned with end of bottom rail. Allow a minimum clearance of 1" (2.5 cm) from stair tread. Secure template with rubber bands. Remove rail.

Measuring and Cutting Railings

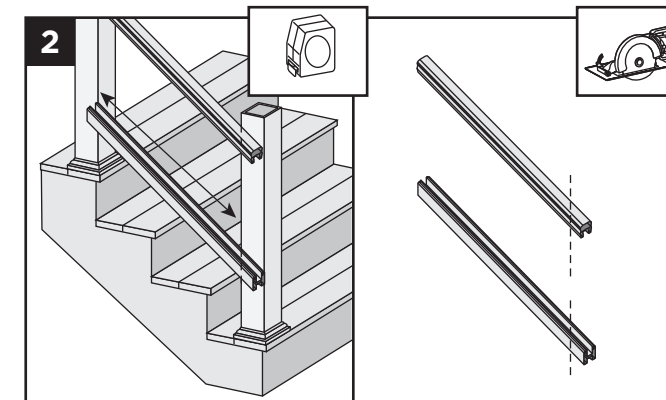

2. Set railing along the nose of the stair treads and mark line at each intersection. Cut rails on marks.

NOTE: If using railing gaskets, subtract 1/16" (0.15 cm) maximum, from each end and cut.

Attaching RSBs to BOTTOM Post

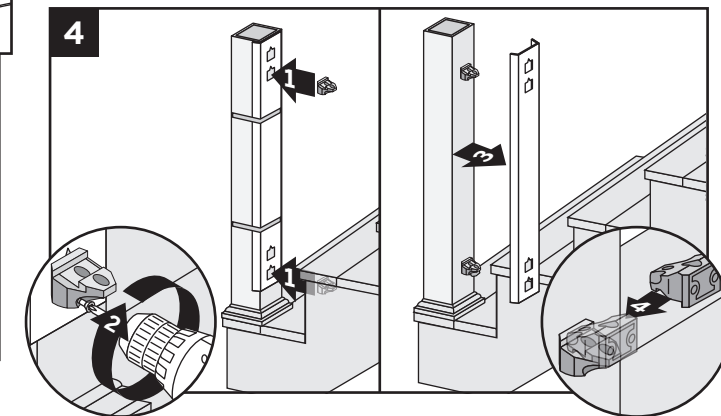

4. Attach upper and lower RSBs to bottom post, **flat side UP**, with wood screws provided. Remove template and place a second RSB, turned upside down, and interlock on each bracket.

HOW TO INSTALL STAIR RAILING/CONTINUED

TREX TRANSCEND®

Positioning RSBs on UPPER Post

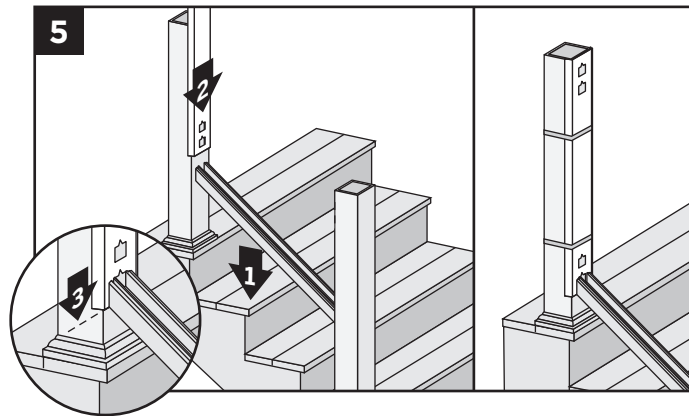

5. Position pre-cut bottom rail between posts. Slide TrexExpress™ Railing Assembly template into position, aligning bottom rail outline on template with end of bottom rail. Use rubber bands to hold template in place. Remove rail.

Attaching RSBs on UPPER Posts

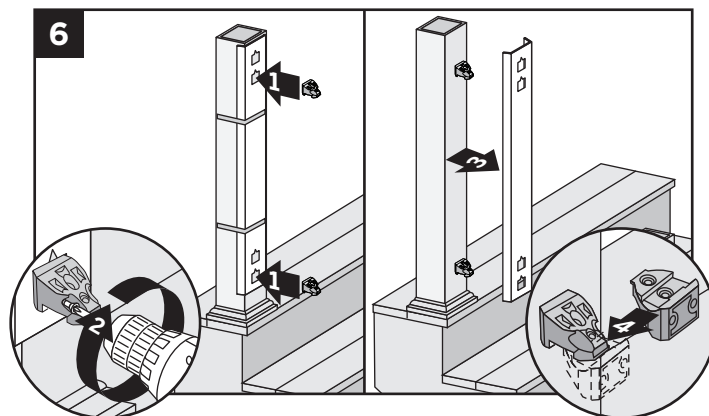

6. Attach upper and lower RSBs to top post, **flat side DOWN**. Remove template. Take second RSB, turn upside down and interlock into each bracket.

Complete Stair Rails Installation

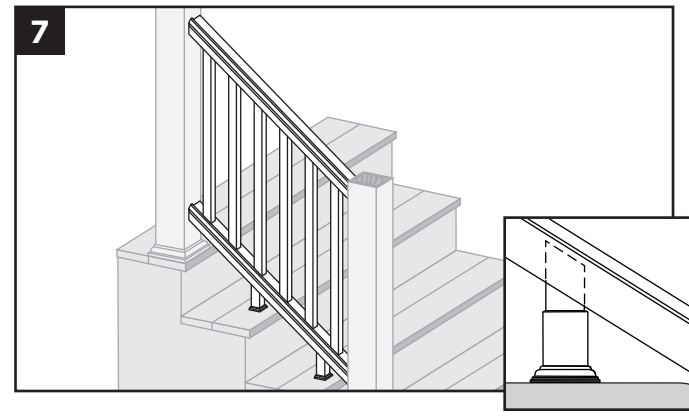

7. Install foot blocks prior to installing lower rail. Refer to "How to Install Foot Blocks" on page 47. For stair application, cut top section of foot block at an angle to match rail, pre-drill, and fasten.

Install top and bottom railings, balusters, and baluster spacers. Refer to Transcend railing beginning on page 37.

Attaching Post Caps

8. Secure post caps with silicone or PVC adhesive.

NOTE: Clean-up any excess adhesive before drying.

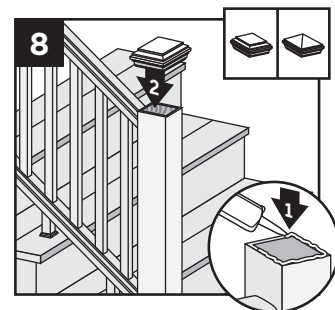

HOW TO INSTALL FOOT BLOCKS

TREX TRANSCEND®

Read all instructions **BEFORE** installation.

NOTE: Foot blocks must be placed before installing bottom rails.

NOTE: One centered foot block is required for every section of railing or stairway section.

Drill Pilot Hole for Foot Block Base Plate

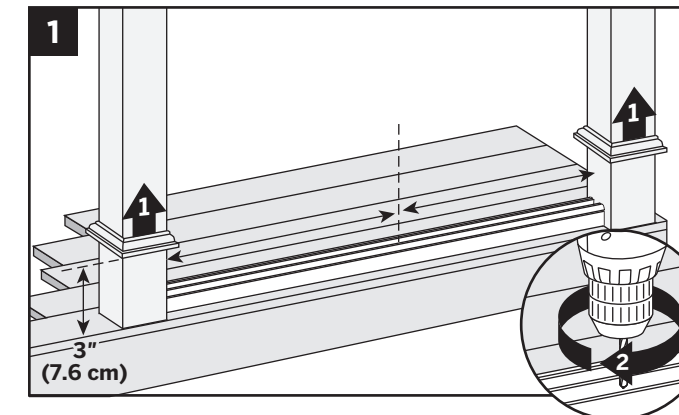

1. Measure distance between posts/post sleeves and mark center on deck surface. Cut universal bottom rail to fit and place between posts. Center rail to width of posts, then drill 1/16" (0.15 cm) pilot hole through center of rail and into deck board.

Installing Foot Block Base Plate

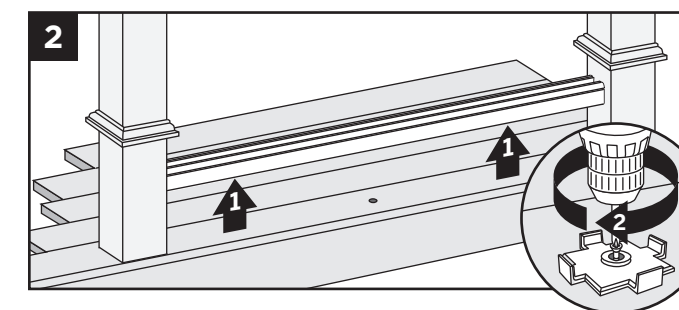

2. Remove rail. Position foot block base plate over pilot hole in deck board and secure foot block base plate with #10 x 3/4" (1.9 cm) stainless steel screws (provided).

Attaching Foot Block to Universal Rail

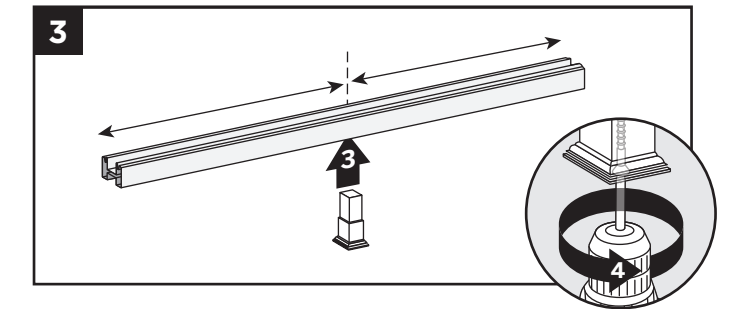

3. Center foot block in universal rail channel at center and attach collapsed foot block (**DO NOT** extend foot block) to rail using 2" (5.1 cm) screw (provided).

NOTE: Top of foot block must be cut at angle for stair railings **BEFORE** attaching to rail.

Installing Bottom Rail with Foot Block

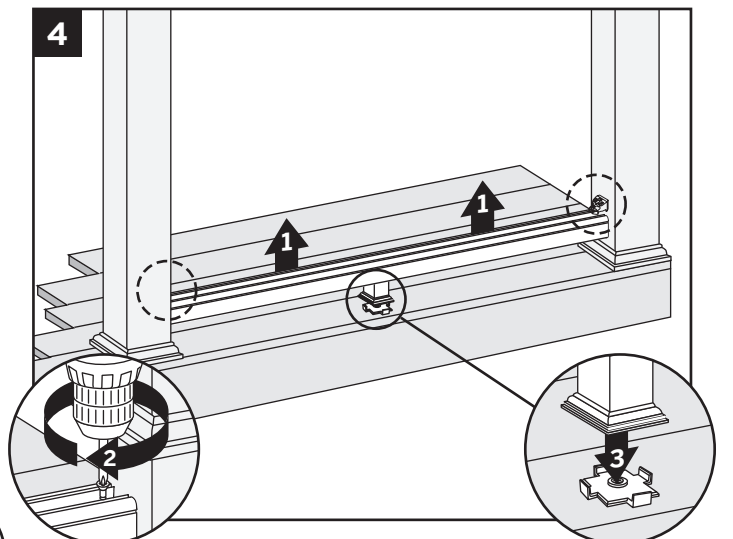

4. Secure rail on RSBs and extend foot block to seat on foot block base plate.

Securing Foot Block

5. With foot block fully seated on base plate, secure with two 3/4" (1.9 cm) retaining screws (provided). Install one on each side of foot block 1-1/2" (3.8 cm) from bottom of base. Place screw plugs.

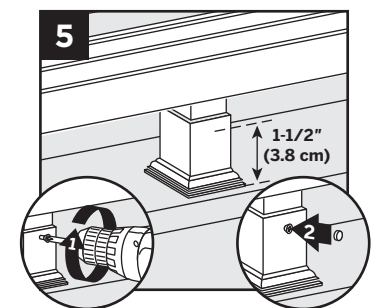

TREX DESIGNER SERIES RAILING®

Trex Designer Series Railing® Parts

- A. Top rail
- B. Bottom rail
- C. Railing support brackets (RSBs)
- D. Balusters*
- E. Trex Railpost™/Post sleeve*
- F. Trex Railpost™ Assembly Tool*
- G. Post cap/Post sleeve cap*
- H. Post skirt/Post sleeve skirt*
- I. TrexExpress™ Designer Series Railing Assembly Tool*

* Item not included in Designer Railing Kit

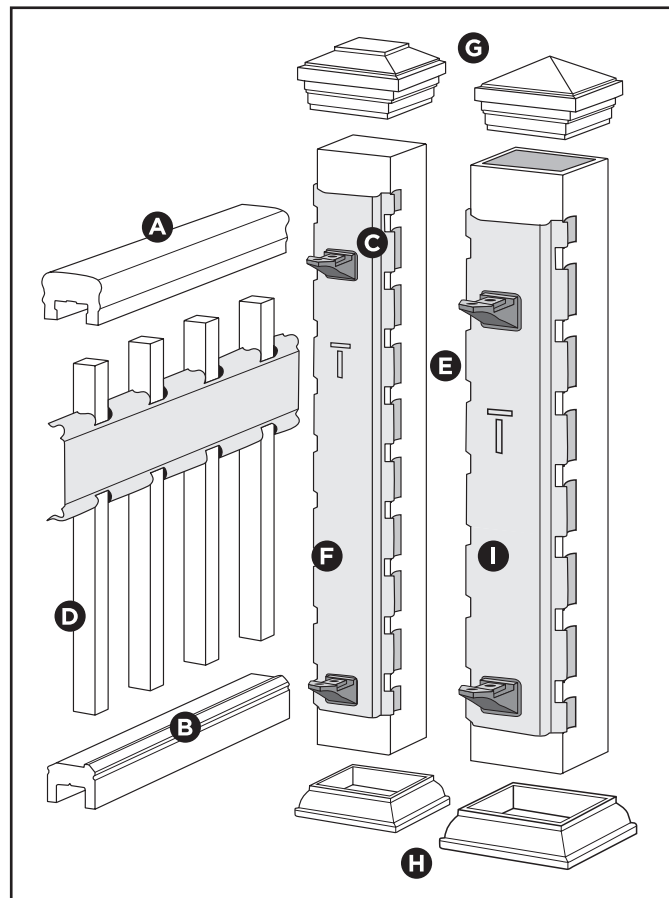

NOTE: Position of bottom rail lip is not a structural component. It is recommended that it be consistently installed either inside or outside.

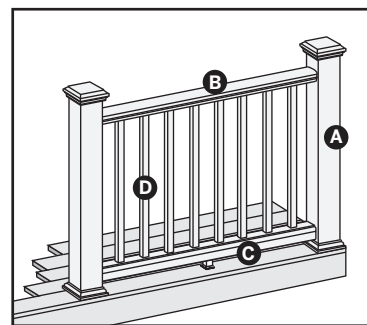

Standard

Cutting post sleeves is **NOT** required.

- A. 4" x 4" (10.2 cm x 10.2 cm) Trex Railpost™ or pressure-treated post with Trex post sleeve
 - B. Top rail
 - C. Bottom rail
 - D. Trex Designer standard balusters
- See page 49 for "How to Install Standard Railing".

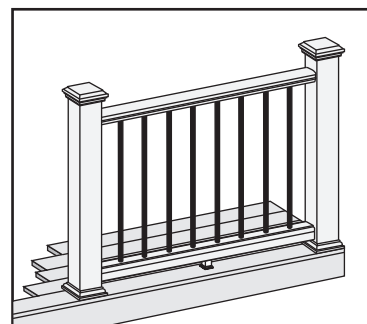

Contemporary

Cutting post sleeves is **NOT** required. Follow instructions for standard Designer installation, using metal balusters for square balusters.

- A. 4" x 4" (10.2 cm x 10.2 cm) Trex Railpost™ or pressure-treated post with Trex post sleeve
 - B. Top rail
 - C. Bottom rail
 - D. Trex Designer contemporary balusters
- See page 52 for "How to Install Contemporary Railing".

HOW TO INSTALL STANDARD RAILING TREX DESIGNER SERIES

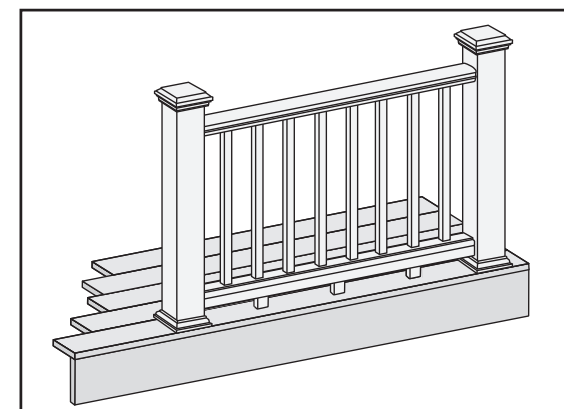

All Trex Designer Series Railing® uses the same application for attaching posts to the rim joists. Posts may be pressure-treated wood or a Trex Railpost™.

Read all instructions BEFORE installation.

Installing Posts

- » Post span = maximum 6' (1.83 m) on center.
- » Attach post using 1/2" (1.3 cm) carriage bolts.
- » Minimum joist size is 2" x 8" (5.1 cm x 20.3 cm).
- » Top bolt must be 1" (2.5 cm) from top of joist.
- » Bottom bolt must be 5-1/8" (13 cm) from top bolt.

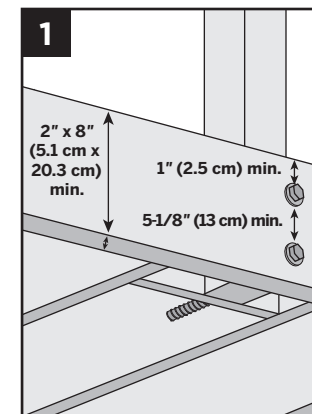

NOTE: Blocking can be added for extra strength.



Trex does not endorse notching any post when it is required to perform as a guardrail system.

Installing Post Sleeve Skirts and Post Sleeves or Post Skirts

- 2a. Slide post sleeve skirt over post and down to rest on decking surface. Slide post sleeve over post and position inside post sleeve skirt. **Cutting post sleeves is NOT required.**

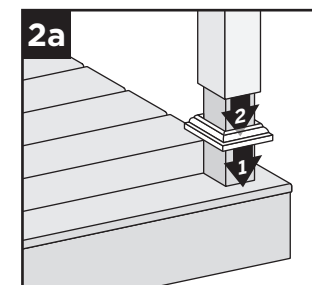

- 2b. If using Trex Railpost™, slide post skirt over post and down to rest on decking surface.

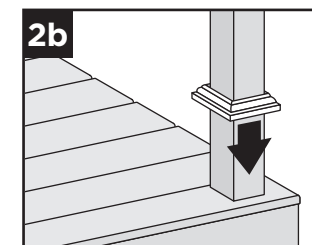

Installing Railing Support Brackets (RSBs)

Option 1: Without TrexExpress™ Designer Series Railing Assembly Tool

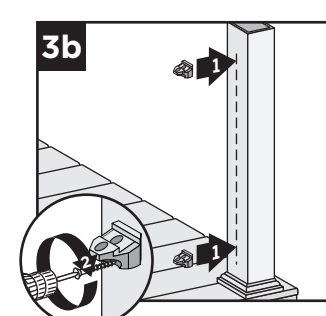
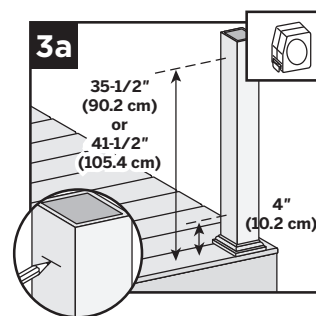

- 3a. For 36" (91.4 cm) height, mark 4" (10.2 cm) and 35-1/2" (90.2 cm) from deck surface **OR** for 42" (106.7 cm) height, mark 4" (10.2 cm) and 41-1/2" (105.4 cm) from the deck surface.

- 3b. Place RSBs on marks, center on posts and secure with 2" (5.1 cm) wood screws (provided). Brackets should be aligned so top part of bracket aligns with mark.

NOTE: Place both **top and bottom RSBs flat side UP.**

Option 2: With TrexExpress™ Designer Series Railing Assembly Tool

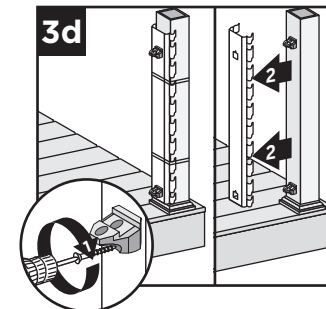
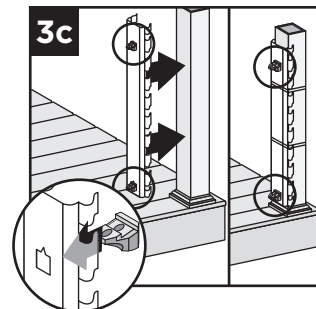

- 3c. Place RSBs in template. Place both **top and bottom RSBs flat side UP.** Secure template on post/post sleeve with tape or rubber band, with bottom of template resting on post skirt. If post skirts are not used, place 1-1/4" (3.2 cm) shim under tool for proper bracket location.
- 3d. Secure RSBs with 2" (5.1 cm) wood screws (provided) and remove template.

HOW TO INSTALL STANDARD RAILING/CONTINUED TREX DESIGNER SERIES

Measuring and Cutting Railings

4. Measure and cut top and bottom rails to fit between posts. Leave 1/16" (0.15 cm) gap at each end for cold weather expansion.

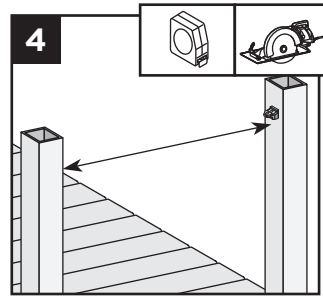

Assembling Rails with Balusters

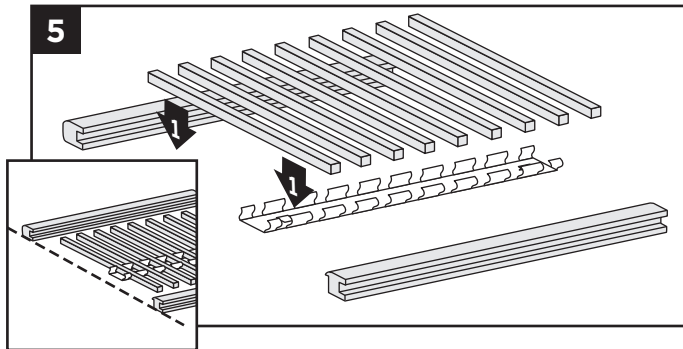

5. Place bottom rails on their sides, lip sides facing up. Using TrexExpress™ Designer Series Railing Assembly Tool, set balusters in designated slots.

NOTE: Using two assembly tools and overlapping these will allow you to span the entire length of the railing section for a 6' (1.83 m) span.

Insert balusters into top rail's channels, align bottom rails parallel to top rails with balusters at equal distance from both ends.

NOTE: If assembly tool is not available, maximum spacing for balusters is 5" (12.7 cm) on center or 3-5/8" (9.2 cm) between balusters.

Securing Balusters to Bottom Rail

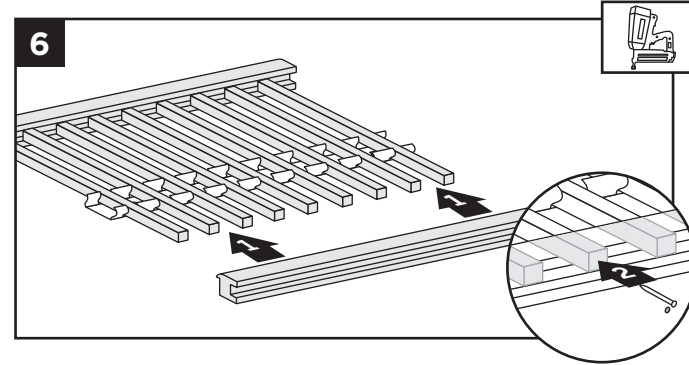

6. Move TrexExpress™ Designer Series Railing Assembly Tool to bottom rail and hold balusters in contact with rail lip. Secure balusters to bottom rail with 2" (5.1 cm) 16 gauge finishing nails through underside of bottom rail.

NOTE: For added stability, drill pilot holes and use #8 - 2" (5.1 cm) screws to secure balusters.

Securing Balusters to Top Rail

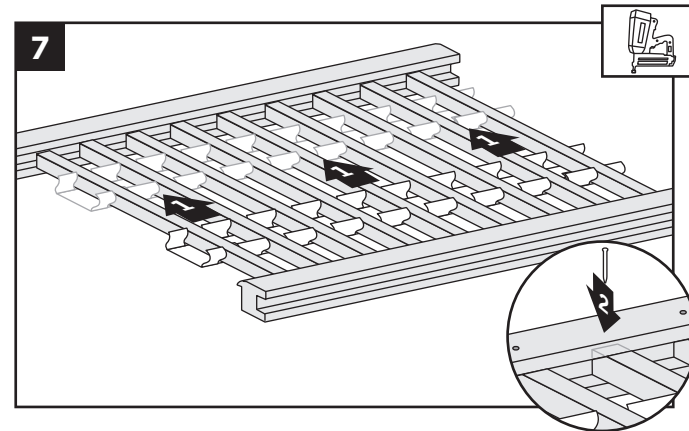

7. Slide TrexExpress™ Designer Series Railing Assembly Tool to top rail and check alignment of balusters. Secure balusters with 2" (5.1 cm) 16 gauge finishing nails through side of rail.

NOTE: For added stability, drill pilot holes and use #8 - 2" (5.1 cm) screws to secure balusters or nail thru both sides of the top rail. **ALWAYS** hold nail gun perpendicular to baluster to be sure the nail drives securely into baluster.

HOW TO INSTALL STANDARD RAILING/CONTINUED DESIGNER STANDARD

Attaching Foot Blocks

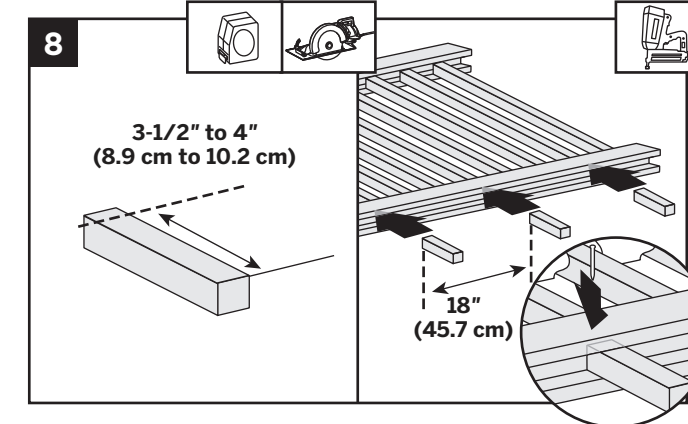

8. Measure distance from deck surface to top of channel in bottom rail, approximately 3-1/2" - 4" (8.9 cm - 10.2 cm). Secure foot blocks with 2" (5.1 cm) 16 gauge finishing nails through side of bottom rail.

NOTE: 2" (5.1 cm) screws can also be used. Pre-drilling would be required.

NOTE: Foot blocks are required every 18" (45.7 cm) for Designer Series Railing.

Securing Railings to Posts

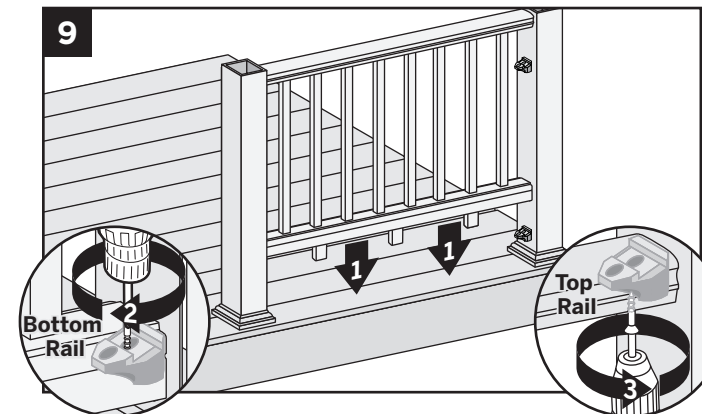

9. Place assembled railing section on RSBs on posts and secure top rail with two 1-1/2" (3.8 cm) screws.

Secure bottom rail with screws through top of rail and into the outermost hole in RSBs.

Bottom rail can also be secured to posts with 16 gauge finishing nails, toenailed from bottom of rail and 1" (2.5 cm) in from the posts.

Finishing Post

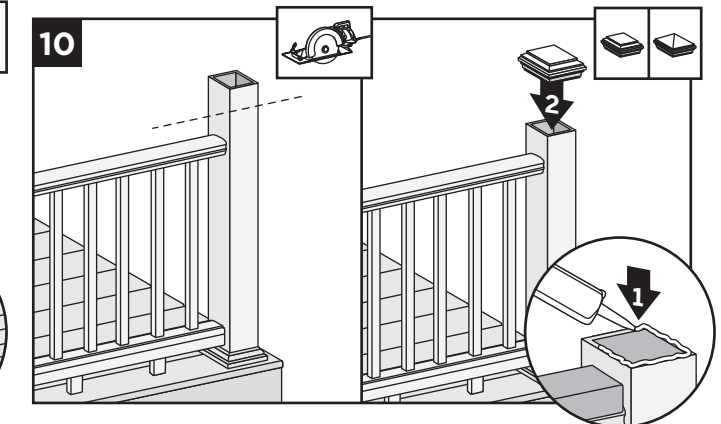

10. Posts and post sleeves can be trimmed but this is not a requirement. Make sure tops of posts are level. Secure post caps with construction-grade adhesive. Clean-up any excess adhesive before drying.

HOW TO INSTALL CONTEMPORARY RAILING TREX DESIGNER SERIES

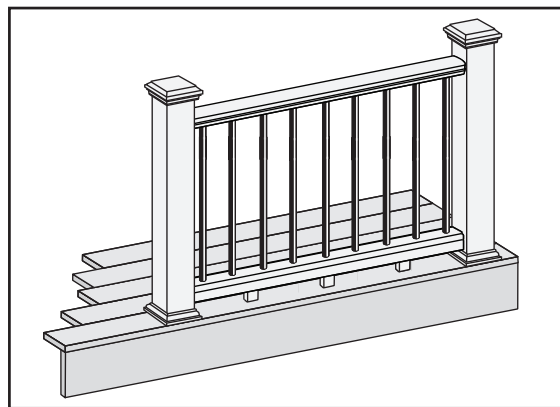

1. Installing Posts

See instructions on page 49.

2. Installing Post Sleeve Skirts and Post Sleeves or Post Skirts

See instructions on page 49.

3. Installing Railing Support Brackets (RSBs)

See instructions on page 51.

4. Measuring and Cutting Railings

See instructions on page 52.

Attaching Foot Blocks

NOTE: Foot blocks should be secured to bottom rail before attaching bottom rail to posts.

Option 1: If using contemporary balusters for foot blocks.

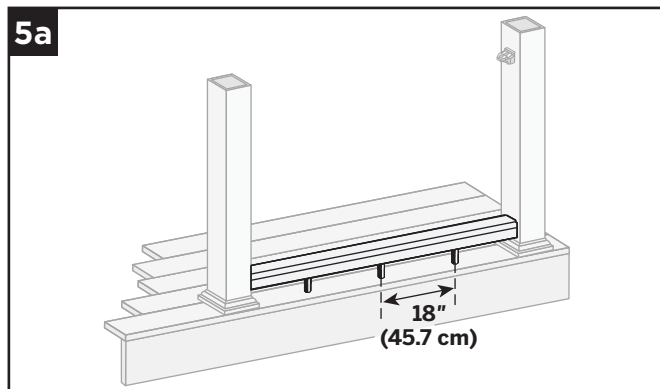

5a. Measure and cut round balusters for foot blocks every 18" (45.7 cm). Secure baluster connectors to bottom rails and deck for mounting balusters.

Option 2: If using Designer balusters for

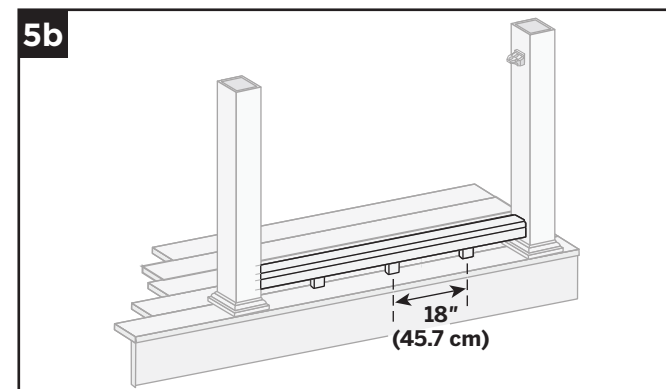

foot blocks.

5b. Measure and cut square balusters for foot blocks every 18" (45.7 cm). Secure foot blocks with 2" (5.1 cm) 16 gauge finishing nails through side of bottom rail.

NOTE: 2" (5.1 cm) screws can also be used. Pre-drilling would be required.

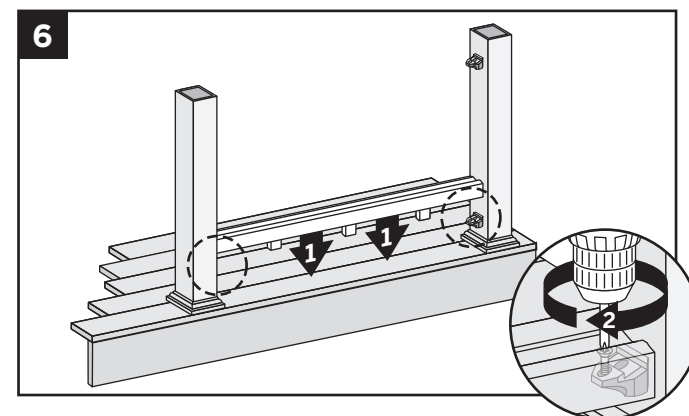

Installing Bottom Rail

6. Secure bottom rail with screws through top of rail and into the outermost hole in RSBs.

Bottom rail can also be secured to posts with 16 gauge finishing nails, toenailed from bottom of rail and 1" (2.5 cm) in from the posts.

HOW TO INSTALL CONTEMPORARY RAILING/CONTINUED TREX DESIGNER SERIES

DETERMINING NUMBER OF BALUSTERS AND SPACING

Number of balusters needed

Length of rail _____" ÷ 4.5 = _____ balusters

- » If number is odd, balusters will be centered.
- » If number is even, balusters will be offset 2-1/4" (5.7 cm) from center.

Installing Baluster Connectors

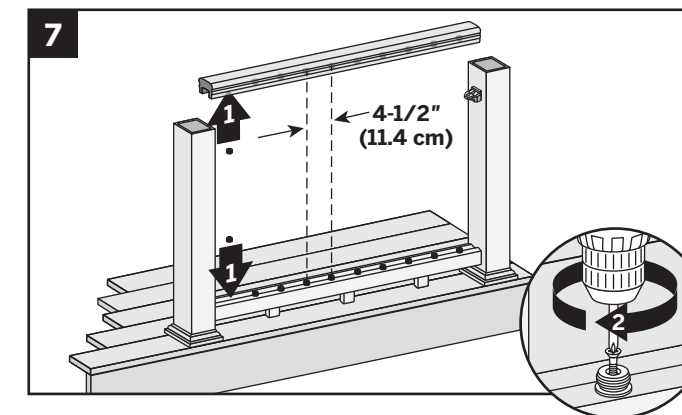

7. Place baluster connectors 4-1/2" (11.4 cm) on center and secure to top and bottom rails with screws.

Connecting Balusters to Bottom Rail

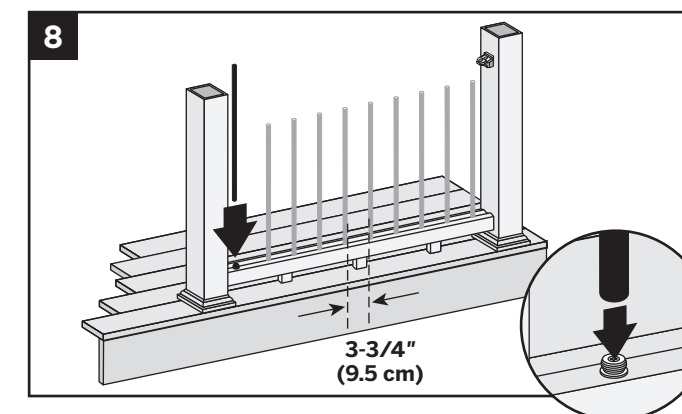

8. Lower each baluster down onto connectors on bottom rail.

Installing Top Rail

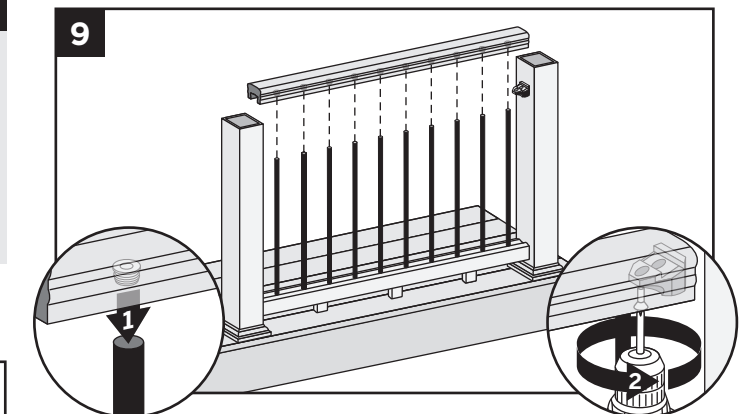

9. Lower top rail with connectors between posts onto RSBs and then secure balusters on connectors. Secure top rail with two 1-1/2" (3.8 cm) screws up through bottom of rail into RSBs.

Finishing Posts

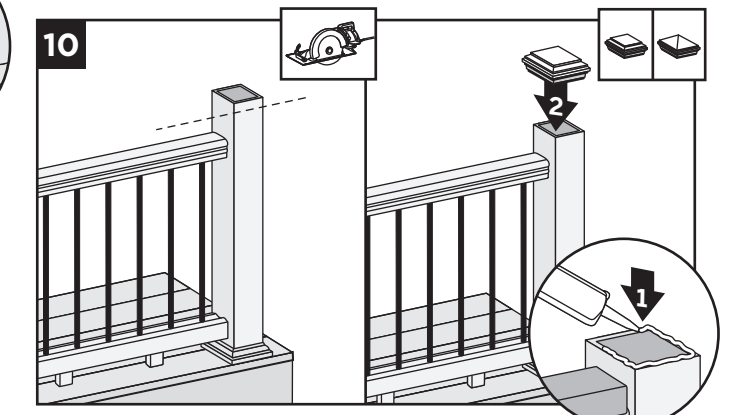

10. Posts and post sleeves can be trimmed but this is not a requirement. Make sure tops of posts are level. Secure post caps with construction-grade adhesive. Clean-up any excess adhesive before drying.



HOW TO INSTALL STANDARD STAIR RAILING TREX DESIGNER SERIES

NOTE: Trex rails meet major building codes for use as a guardrail system. Local municipalities may require a graspable handrail on stairways. Trex offers an ADA code-compliant handrail system. Check with your local building code officials for local requirements.

Installing Posts for Stair Railing

1. In most cases, a railpost or post sleeve longer than 39" (99.1 cm) is required for the lower stair rail sections to accommodate stair angle. Both top and bottom posts need to be installed on outside corners (nose) of stair treads.

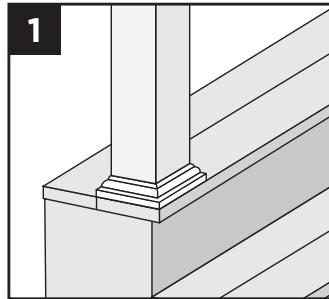

NOTE: Posts, post sleeve skirts, and post sleeves are installed per standard Designer railing instructions. See page 49.

Measuring and Cutting Railings

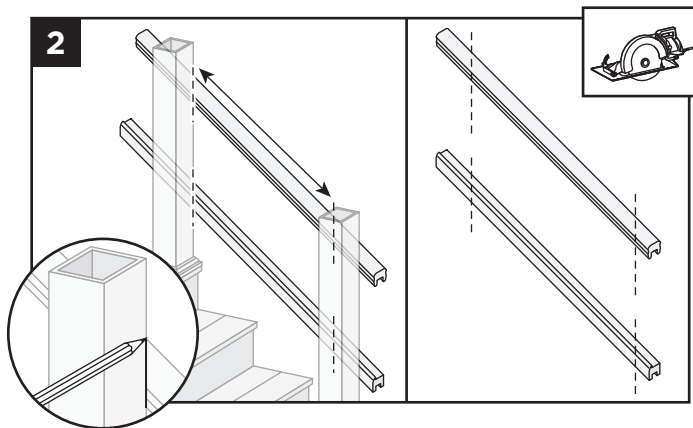

2. Determine length and angle of top and bottom rail. Set railings on the nose of the stair tread and mark line at each intersection.

Cut rails on marks and place in position on supports. (Supports can be made from scrap material.)

NOTE: Allow a minimum clearance of 1" (2.5 cm) from stair treads.

NOTE: Check local building codes for railing height requirements.

Installing Bottom RSBs on Upper and Lower Posts

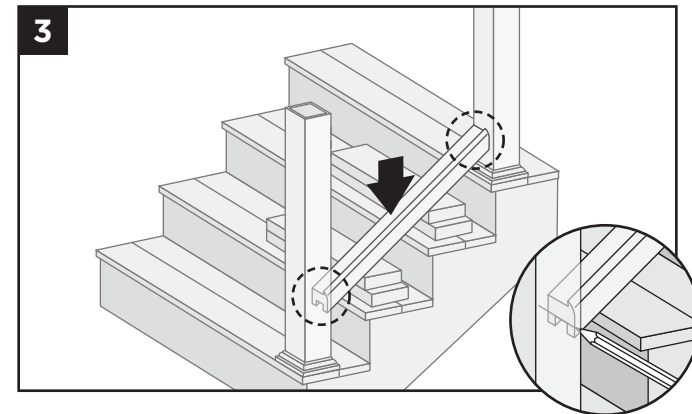

3. Position bottom rail between posts and set to proper height from stair tread. Support on blocks cut from scrap materials. Mark both posts where underside of the bottom rail intersects.

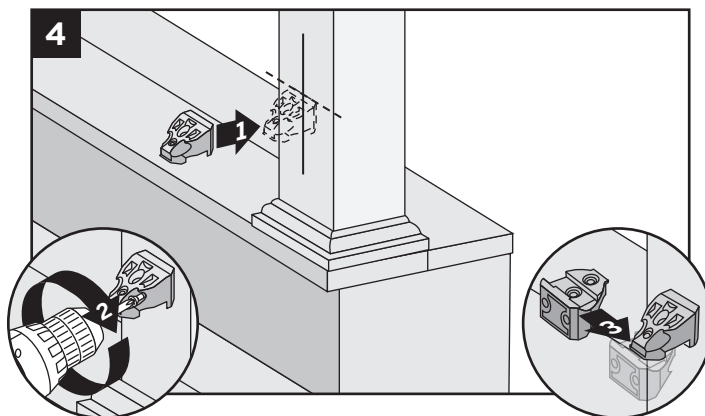

4. Position one RSB centered on upper post with top of bracket aligned with mark on post, **flat side DOWN**, and secure with two 2" (5.1 cm) screws. Using a second RSB, turn upside down and interlock into bottom bracket on upper stair post.

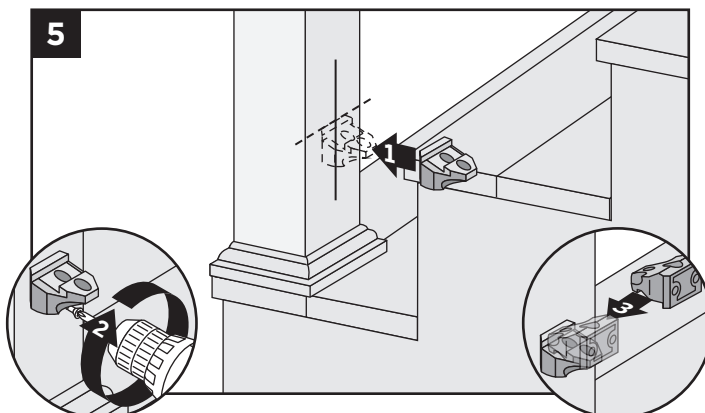

5. Position one RSB centered on lower post with top of bracket aligned with mark on post, **flat side UP**, and secure with two 2" (5.1 cm) screws. Using a second RSB, turn upside down and interlock into bottom bracket on lower stair post.

HOW TO INSTALL STANDARD STAIR RAILING/CONTINUED TREX DESIGNER SERIES

Installing Top Rail RSBs on Upper and Lower Posts

6. Determine height of top rail from bottom rail and while holding top rail in place, and parallel to bottom rail, mark posts where underside of rail intersects.
7. Follow Steps 4-5 to install top rail RSBs on upper and lower posts.

Measuring and Cutting Balusters

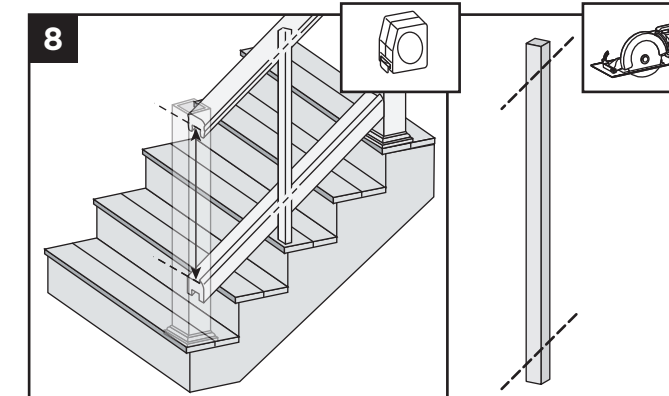

8. Measure and cut balusters to proper height and angle of stairs.

Assembling Rails with Baluster

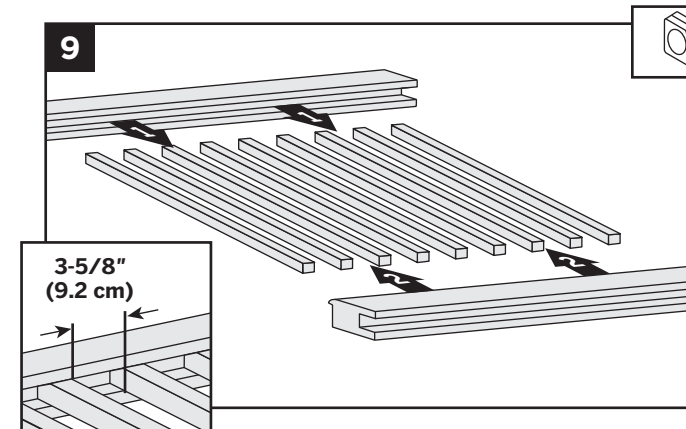

9. Insert and space balusters in top rails, then align bottom rails at parallel angle to top rails with balusters spaced the same and in contact with bottom rail lip.

NOTE: Maximum spacing is 5" (12.7 cm) on center or 3-5/8" (9.2 cm) between balusters.

Securing Balusters to Top and Bottom Rail

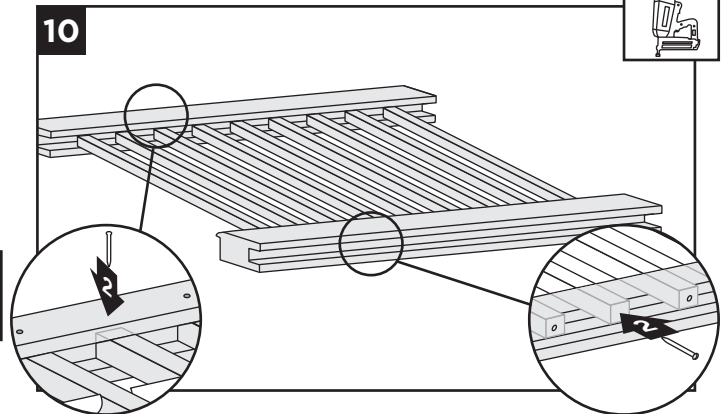

10. Secure balusters to top rail with 2" (5.1 cm) 16 gauge finishing nails through side of rail. Secure balusters to bottom rail with 2" (5.1 cm) finishing nails through underside of bottom rail.

Attaching Foot Blocks

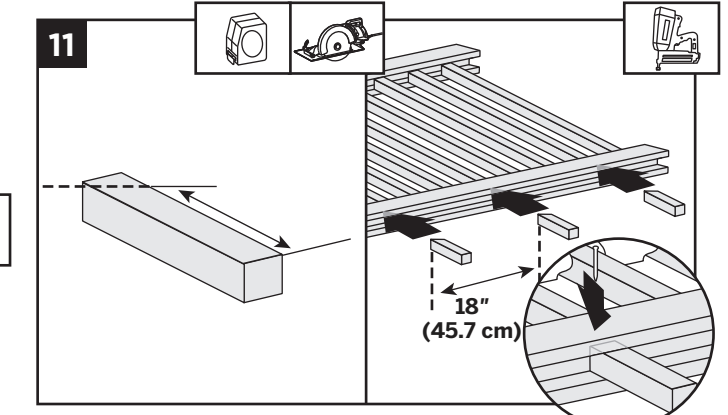

11. Measure and determine angle to cut foot blocks. Secure with 2" (5.1 cm) 16 gauge finishing nails through side of bottom rail.

NOTE: 2" (5.1 cm) screws can also be used. Pre-drilling would be required.

NOTE: Foot blocks are required every 18" (45.7 cm).

HOW TO INSTALL STANDARD STAIR RAILING/CONTINUED TREX DESIGNER SERIES

Mounting Rails on Posts

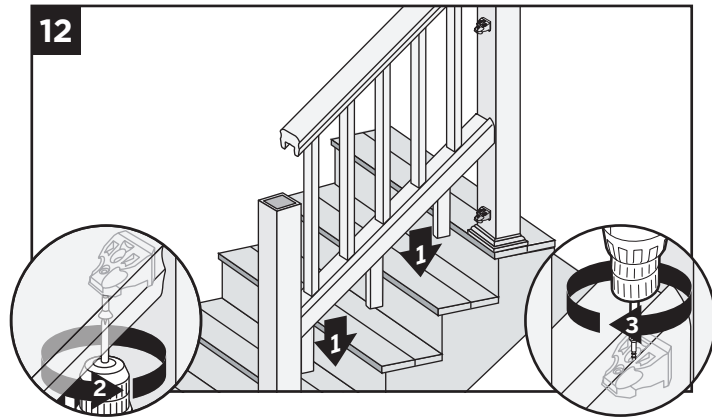

12. Place assembled railing section on RSBs on posts and secure top rail with two 1-1/2" (3.8 cm) screws. Secure bottom rail with screws through outermost holes in RSBs.

Bottom rail can also be secured to posts with 16 gauge finishing nails, toenailed through the side of rail into the posts, 1-1/2" (3.8 cm) from bottom of rail and 1" (2.5 cm) from the post.

Finishing Posts

13. Posts and post sleeves can be trimmed but this is not a requirement. Make sure tops of posts are level. Secure post caps with construction-grade adhesive. Clean-up any excess adhesive before drying.

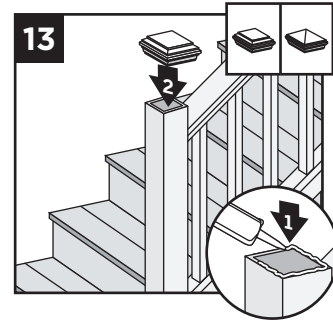

HOW TO INSTALL CONTEMPORARY STAIR RAILING TREX DESIGNER SERIES

- Installing Posts for Stair Railing**
See instructions on page 54.
- Measuring and Cutting Railings**
See instructions on page 54.
- Installing Bottom RSBs on Upper and Lower Posts** See instructions on page 54.
- Installing Top RSBs on Upper and Lower Posts** See instructions on page 55.

Installing Foot Blocks

Option 1: If using contemporary balusters for foot blocks.

- 8a. Measure and cut round balusters for foot blocks every 18" (45.7 cm). Secure baluster connectors to bottom rail and stair treads for mounting balusters.

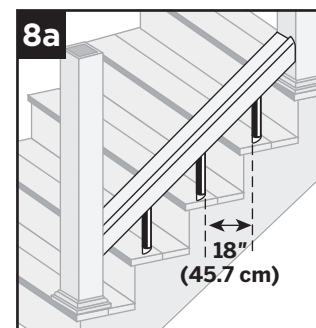

Option 2: If using designer balusters for foot blocks.

- 8b. Measure and cut square balusters for foot blocks every 18" (45.7 cm). Secure foot blocks with 2" (5.1 cm) 16 gauge finishing nails through sides of bottom rail.

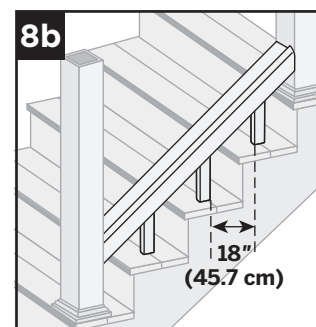

NOTE: 2" (5.1 cm) screws can also be used. Pre-drilling would be required.

HOW TO INSTALL CONTEMPORARY STAIR RAILING/CONTINUED TREX DESIGNER SERIES

Installing Bottom Rail

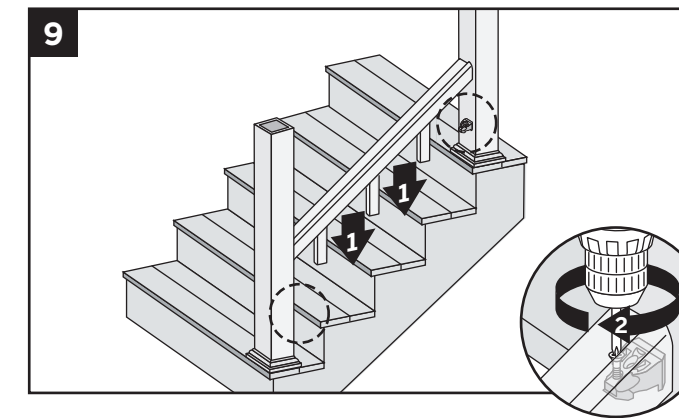

9. Secure bottom rail with screws through top of rail and into the outermost hole in RSBs.

Bottom rail can also be secured to posts with 16 gauge finishing nails, toenailed from bottom of rail and 1" (2.5 cm) in from the posts.

DETERMINING NUMBER OF BALUSTERS AND SPACING

Number of balusters needed

Length of rail _____" ÷ 5.5 = _____ balusters

- » If number is odd, balusters will be centered.
- » If number is even, balusters will be offset 2-3/4" (7 cm) from center.

Installing Stair Baluster Connectors

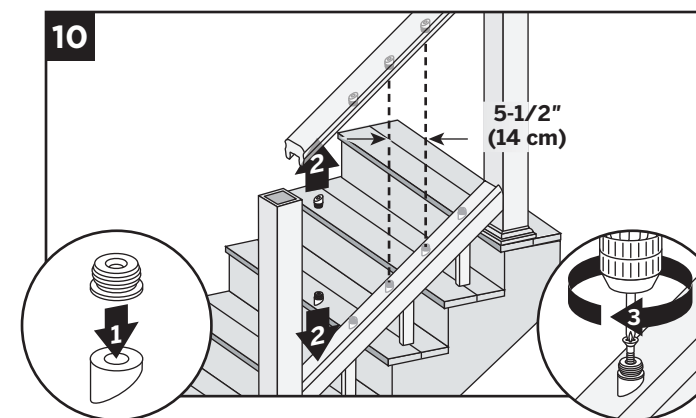

10. Place stair baluster connectors 5-1/2" (14 cm) on center and secure to top and bottom rails with screws.

NOTE: Stair baluster connectors are sold separately. Black 3/4" (1.9 cm) Stair Baluster Connectors Part number: **BK075SCON**

Connecting Balusters to Bottom Rail

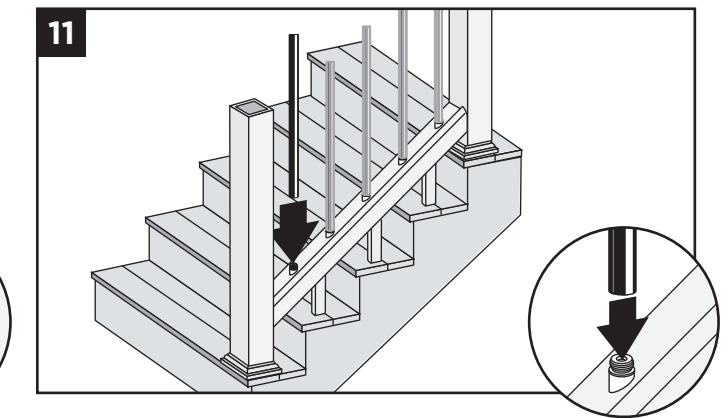

11. Lower each baluster down onto connectors on bottom rail.

Installing Top Rail

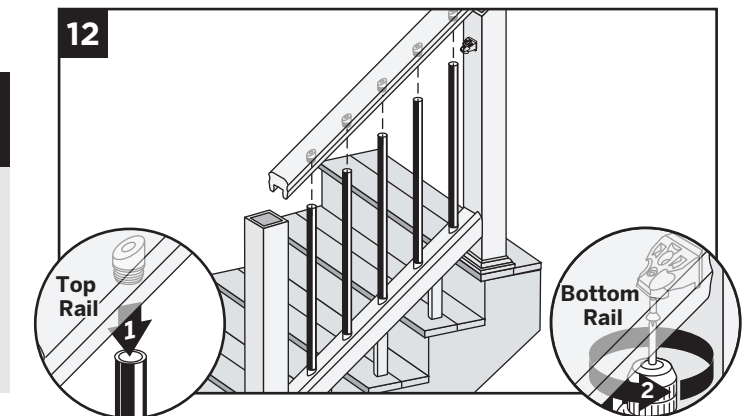

12. Lower top rail with connectors between posts onto RSBs and then place balusters on connectors. Secure rail sections with screws up through bottom of rail into RSBs.

Finishing Posts

13. Posts and post sleeves can be trimmed but this is not a requirement. Make sure tops of posts are level. Secure post caps with construction-grade adhesive. Clean-up any excess adhesive before drying.

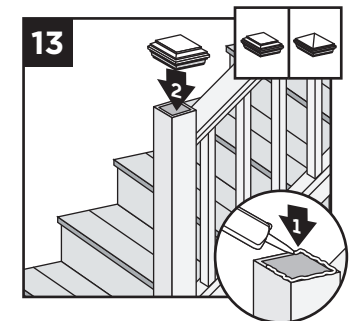

TREX® TRADITIONAL RAILING

Trex® Traditional Railing Parts List

- A. Top rail
- B. Lateral rail
- C. Balusters
- D. Post sleeve
- E. Post skirt/Post sleeve skirt
- F. Trex decking
- G. TrexTrim™ or Trex fascia
- H. Code-approved wood joist - 2" x 8" (5.1 cm x 20.3 cm)

- I. Code-approved wood rim joist - 2" x 8" (5.1 cm x 20.3 cm) or larger
 - J. Foot block
 - K. Trex Railpost™
- » Escapes and 5" (12.7 cm) Contours cannot be used for top rail.
- » 6" x 6" (15.2 cm x 15.2 cm) post sleeve cannot be used with any Trex Traditional railing installs.
- » Trex Post Mounts (for decking or concrete) cannot be used with Trex Traditional Railing.

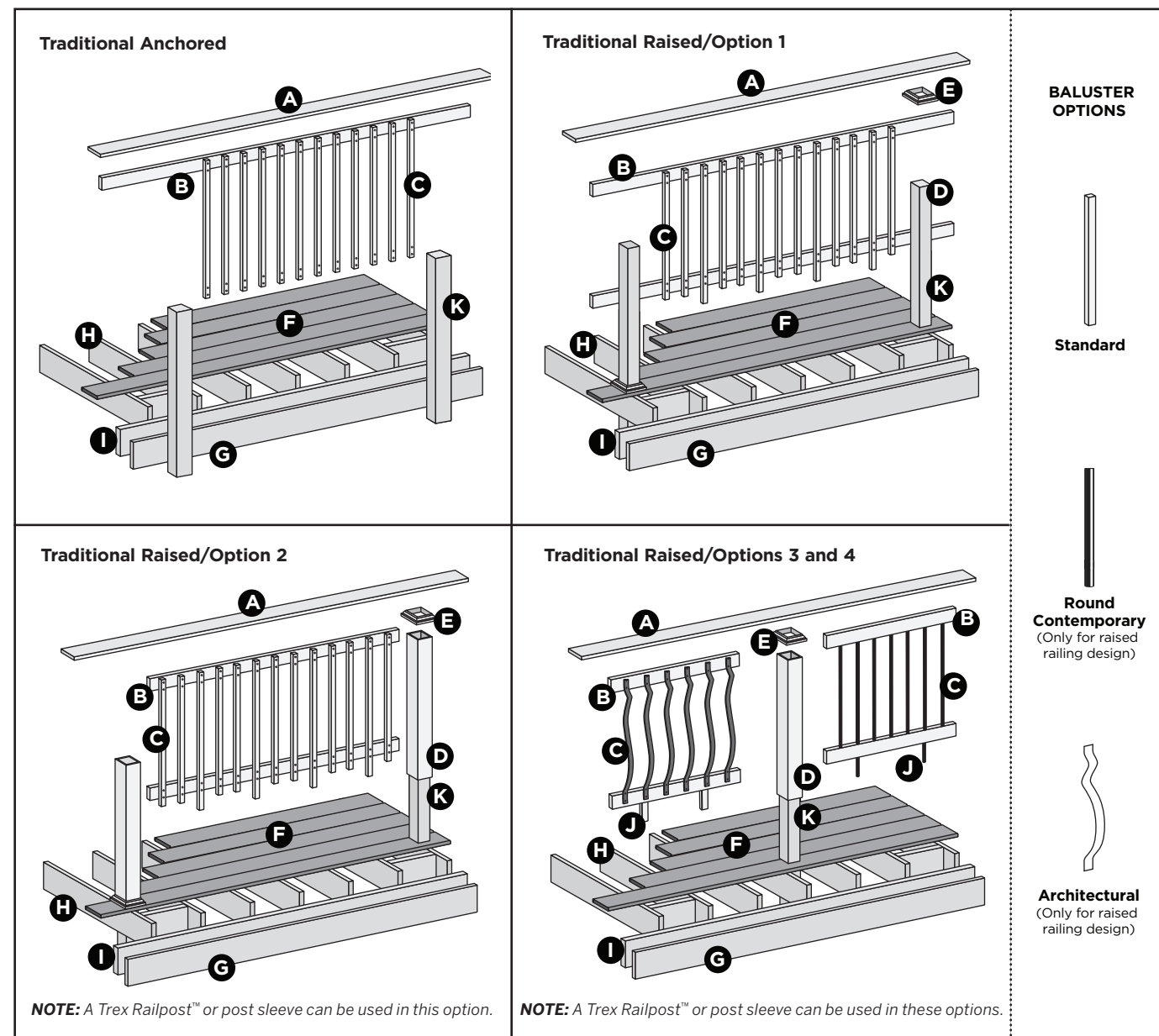

NOTE: All Trex Traditional Railings are designed to span posts at maximum of 6' (1.83 m) on center.

NOTE: The Trex guardrail system complies with current BOCA, ICBO, SBCCI and ICC model codes for a guardrail system. See local building codes for other requirements. For more detailed installation instructions, visit trex.com

TREX® TRADITIONAL/ANCHORED DECK RAILING

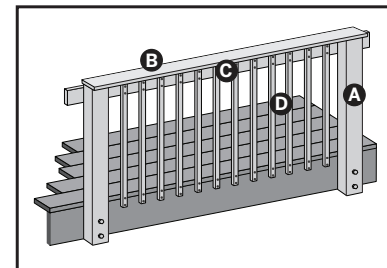

- A. 4" x 4" (10.2 cm x 10.2 cm) Trex Railpost™.
 - NOTE: DO NOT USE** post sleeves.
 - B. Deck board top rail
 - NOTE: 5" (12.7 cm) Contours and Escapes cannot be used.**
 - C. 2" x 4" (5.1 cm x 10.2 cm) lateral top rail
 - D. Trex Designer balusters
- See page 60 for "How to Install Traditional Anchored Railing".

TREX® TRADITIONAL/RAISED DECK RAILING

Rails Mounted on Side of Post

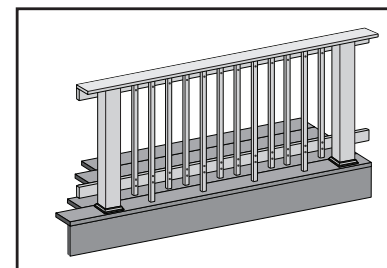

With standard Trex Designer® Balusters/Option 1

- A. 4" x 4" (10.2 cm x 10.2 cm) Trex Railpost™
 - NOTE: DO NOT USE** post sleeves.
 - B. Deck board top rail
 - NOTE: DO NOT USE** with 5" (12.7 cm) Contours and Escapes.
 - C. 2" x 4" (5.1 cm x 10.2 cm) lateral top and bottom rail
 - D. Trex Designer balusters
- See page 61 for "How to Install Raised Railing/Option 1".

Rails Mounted Between Posts

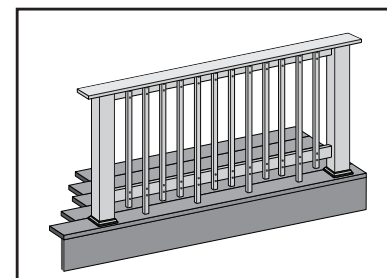

With Standard Trex Designer Balusters/Option 2

- A. 4" x 4" (10.2 cm x 10.2 cm) Trex Railpost™ or pressure-treated post with Trex Designer post sleeve or Trex Transcend® 4" x 4" (10.2 cm x 10.2 cm) post sleeve
 - B. Deck board top rail
 - NOTE: DO NOT USE** with 5" (12.7 cm) Contours and Escapes.
 - C. 2" x 4" (5.1 cm x 10.2 cm) Lateral top and bottom rail
 - D. Trex Designer balusters
- See page 63 for "How to Install Raised Railing/Option 2".

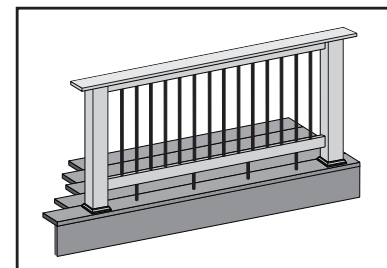

With Contemporary Balusters/Option 3

- A. 4" x 4" (10.2 cm x 10.2 cm) Trex Railpost™ or pressure-treated post with Trex Designer post sleeve or Trex Transcend® 4" x 4" (10.2 cm x 10.2 cm) post sleeve
 - B. Deck board top rail
 - NOTE: DO NOT USE** with 5" (12.7 cm) Contours and Escapes.
 - C. 2" x 4" (5.1 cm x 10.2 cm) lateral top rail
 - D. Trex Traditional Contemporary balusters
- See page 65 for "How to Install Raised Railing/Option 3".

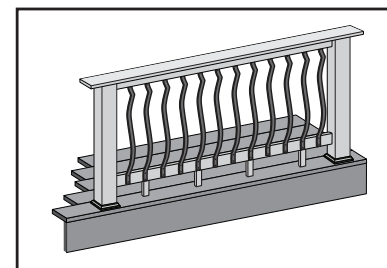

With Architectural Balusters/Option 4

- A. 4" x 4" (10.2 cm x 10.2 cm) Trex Railpost™ or pressure-treated post with Trex Designer post sleeve or Trex Transcend® 4" x 4" (10.2 cm x 10.2 cm) post sleeve
 - B. Deck board top rail
 - NOTE: DO NOT USE** with 5" (12.7 cm) Contours and Escapes.
 - C. 2" x 4" (5.1 cm x 10.2 cm) lateral top rail
 - D. Trex Traditional Architectural balusters
- See page 69 for "How to Install Raised Railing/Option 4".

TRADITIONAL COLORS: See inside back cover for color palette.

HOW TO INSTALL ANCHORED RAILING TREX® TRADITIONAL

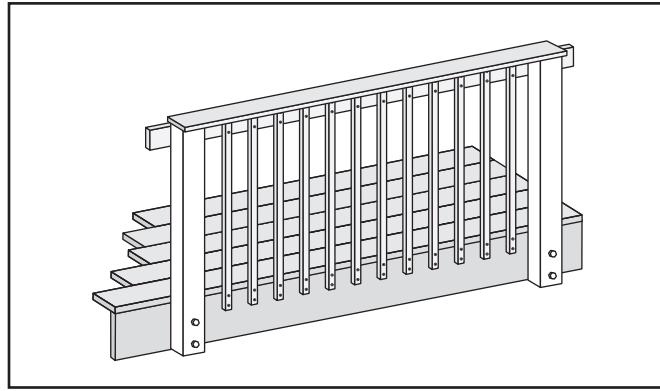

NOTE: Post sleeves and post sleeve skirts **CANNOT** be used for this application. **ONLY** for use with Trex Railpost™.

Installing Trex Railpost™

- » Attach post using 1/2" (1.3 cm) carriage bolts.
- » Post span = maximum 6' (1.8 m) on center.
- » Minimum joist size is 2" x 8" (5.1 cm x 20.3 cm)
- » Top bolt must be 1" (2.5 cm) from top of joist.
- » Bottom bolt must be 5-1/8" (13 cm) from top bolt.

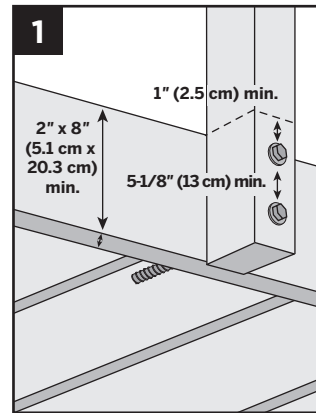

NOTE: Trex does not endorse notching any post that will serve as a guardrail system.

Cutting Posts to Length and Installing Top Rail

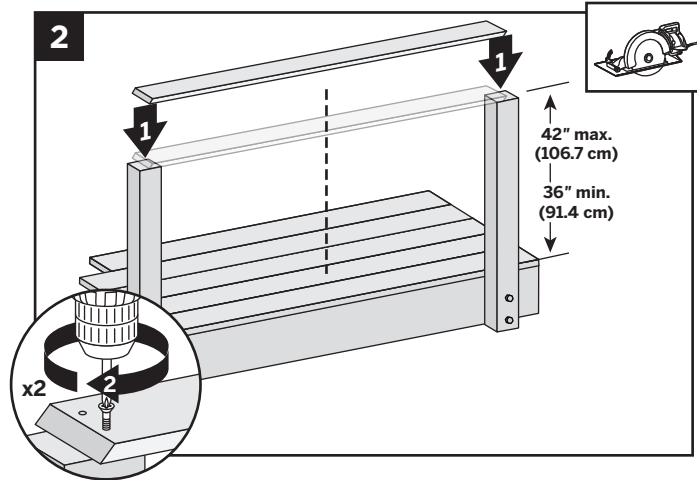

2. Cut posts to designated height as measured from top of decking surface. Place a deck board across each set of posts. Position board so it overhangs the post towards the deck surface 1-1/2" (3.8 cm).

Scarf cut each end of deck board and use two exterior-approved screws per end to secure boards to posts.

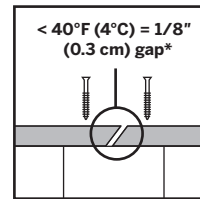

***NOTE:** If installing at below 40°F (4°C), leave 1/8" (0.3 cm) gap in scarf joints between boards.

Installing Lateral Rail

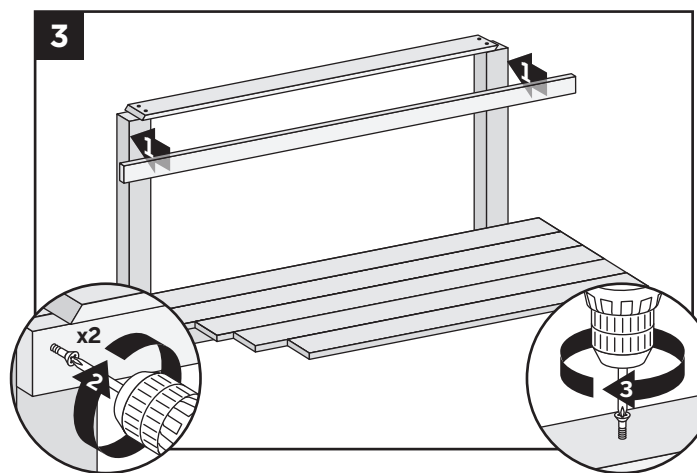

3. Place lateral rail across the posts under the overhanging top rail on the inside of the posts, drill pilot holes, and secure with two 2-1/2" (6.4 cm) exterior-approved screws positioned diagonally on each end. Attach top rail to lateral rail every 12" (30.5 cm).

HOW TO INSTALL ANCHORED RAILING/CONTINUED TREX® TRADITIONAL

Installing Balusters

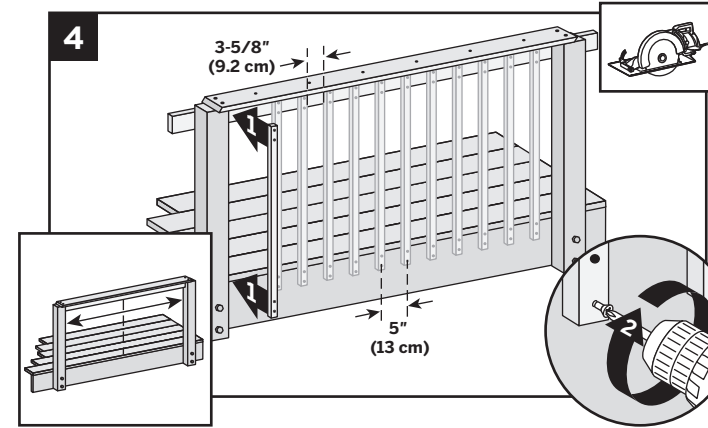

4. Cut balusters to desired length, pre-drill two holes at top and bottom on side that will face outward on each baluster. Locate center between posts, mark and place first baluster and secure with four 2-1/2" (6.4 cm) exterior-approved screws. Space balusters to the left and right a maximum of 3-5/8" (9.2 cm) edge-to-edge or 5" (13 cm) on center.

NOTE: ALWAYS consult your local building department prior to purchase and installation.

HOW TO INSTALL RAISED RAILING TREX® TRADITIONAL/OPTION 1

Rails ON SIDES of Posts with STANDARD Balusters

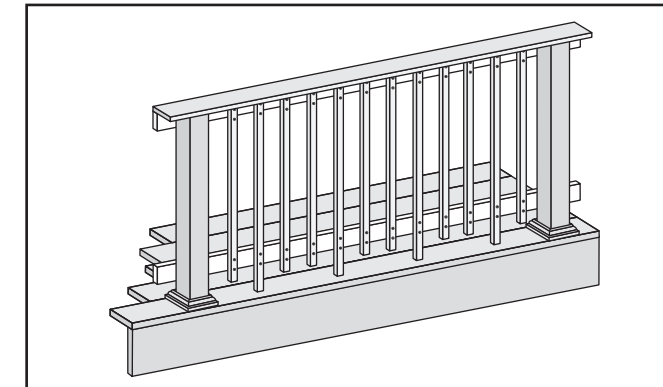

All Trex® Traditional raised handrail installations use the same method for attaching posts to the rim joists. Posts may be pressure-treated wood or a Trex Railpost™.*

***NOTE:** Post sleeves **CANNOT** be used for this option.

Installing Pressure-Treated Posts or Trex Railposts™

- » Attach posts using 1/2" (1.3 cm) carriage bolts.
- » Minimum joist size is 2" x 8" (5.1 cm x 20.3 cm).
- » Top bolt must be 1" (2.5 cm) from top of joists.
- » Bottom bolts must be 5-1/8" (13 cm) from top bolts.

NOTE: Blocking can be added for extra strength.

Installing Post Skirts

2. Slide post skirt over post and down to rest on decking surface.

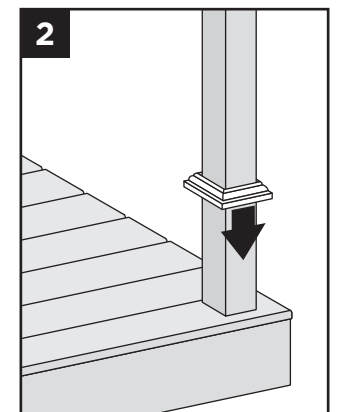
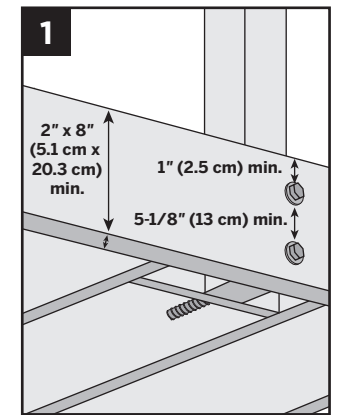

HOW TO INSTALL RAISED RAILING/CONTINUED TREX® TRADITIONAL/OPTION 1

Cutting Posts to Length and Installing Top Rail

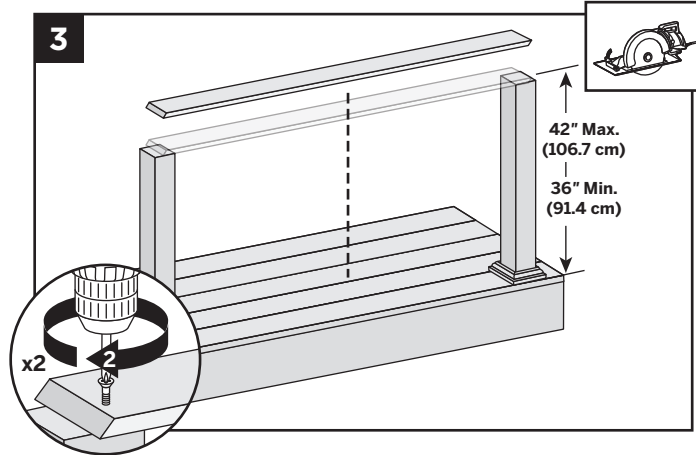

3. Cut posts to designated height as measured from top of decking surface. Measure distance between posts from center-to-center.

Make scarf cuts on each end of deck board and use two exterior-approved screws per end to secure boards to posts with board centered over posts.

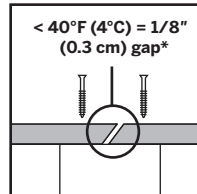

***NOTE:** If installing at below 40°F (4°C) leave 1/8" (0.3 cm) gap in scarf joints between boards.

Cutting Lateral Rails

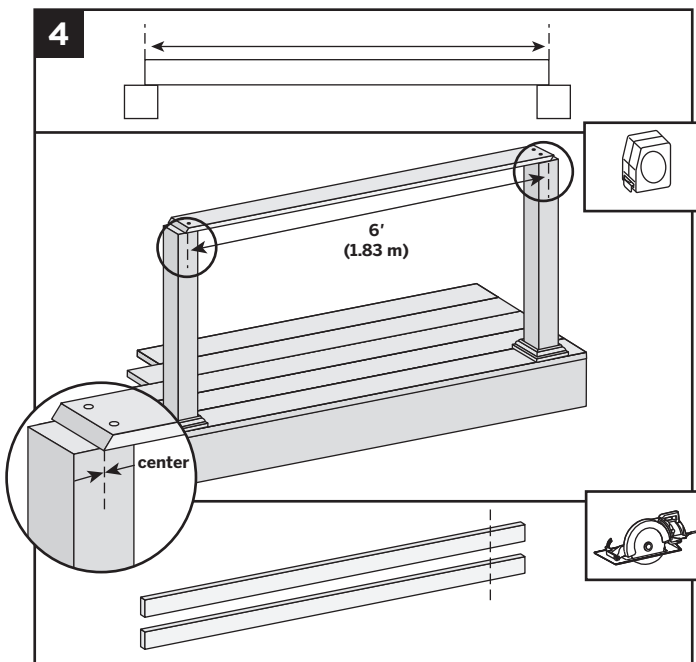

4. Measure distance between posts on 6' (1.83 m) center and cut two 2" x 4" (5.1 cm x 10.2 cm) lateral rails to fit. Leave 1/16" (0.15 cm) gap at each end for cold weather expansion.

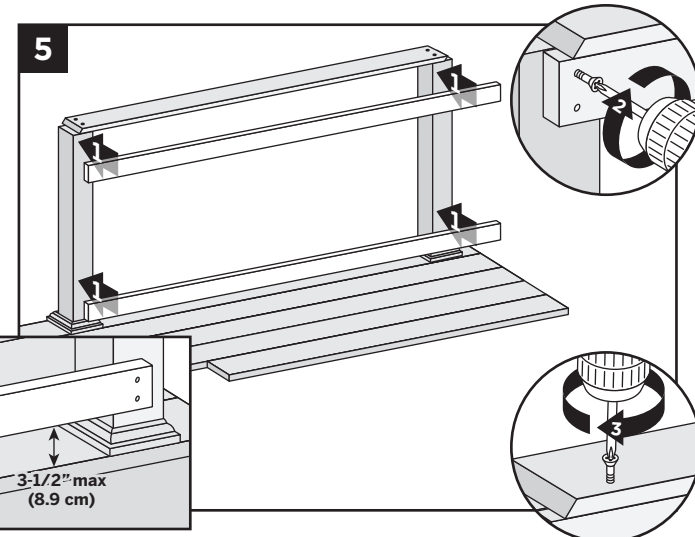

5. Secure with 2-1/2" (6.4 cm) composite-approved screws and attach top rail with one screw every 12" (30.5 cm).

Installing Balusters

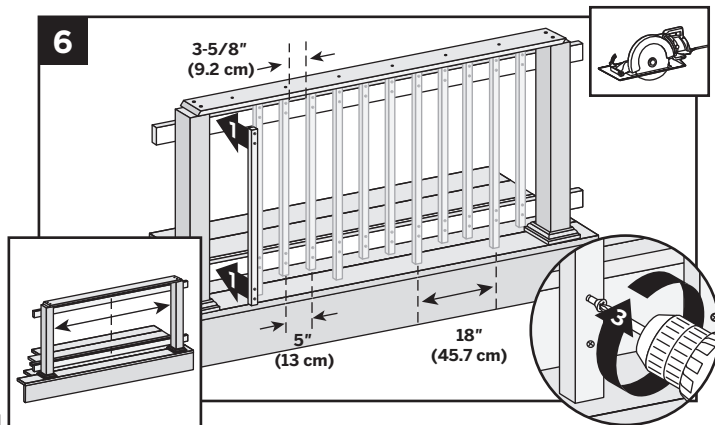

6. Cut balusters to length, pre-drill two holes at top and bottom sides that will face outward on each baluster. Locate the centers between posts, mark and place first baluster and secure with four 2-1/2" (6.4 cm) exterior-approved screws. Space balusters to the left and right a maximum of 3-5/8" (9.2 cm) edge-to-edge or 5" (13 cm) on center.
7. One baluster must extend to the decking surface every 18" (45.7 cm). Typically four per 6' (1.83 m) application.

HOW TO INSTALL RAISED RAILING TREX® TRADITIONAL/OPTION 2

Rails BETWEEN Posts with STANDARD Trex Balusters

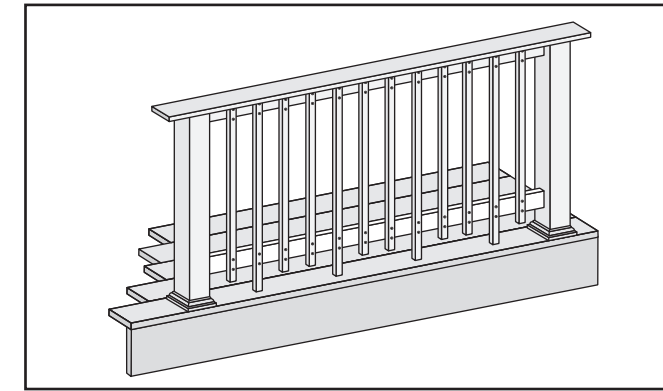

1. **Installing Pressure-Treated Posts or Trex Railposts™**
See instructions on page 61.

Installing Post Sleeve Skirts and Post Sleeves

2. Slide post skirt over post and down to rest on decking surface. Slide post sleeve over post and position inside post skirt.

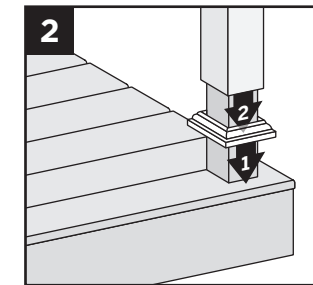

NOTE: Shims can be used to plumb post sleeves.

Optional: Installing Post Skirts (for use with Trex Railpost™)
See instructions on page 61.

3. **Cutting Posts to Length and Installing Top Rail**
See instructions on page 62.

Cutting Lateral Rails

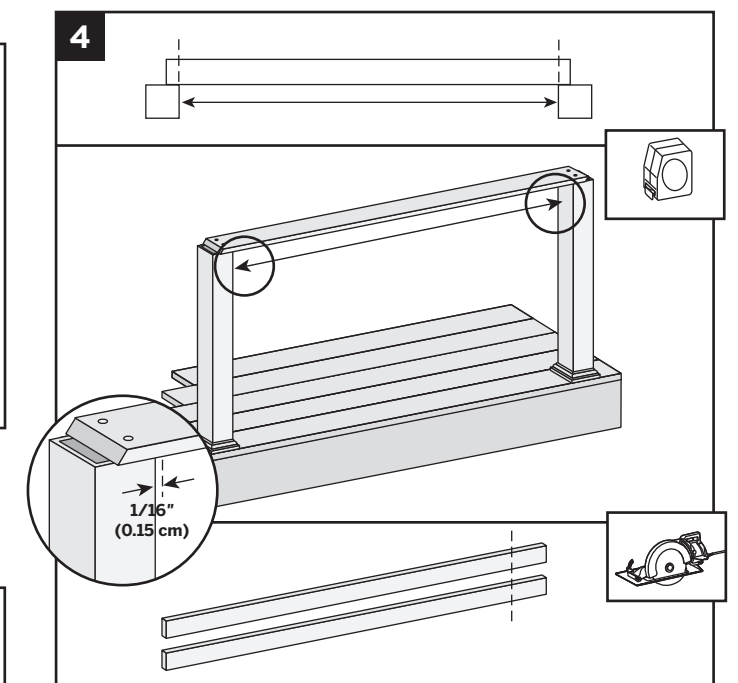

4. Measure distance between inside edges of posts and cut two 2" x 4" (5.1 cm x 10.2 cm) lateral rails to fit. Leave 1/16" (0.15 cm) gap at each end for cold weather expansion.

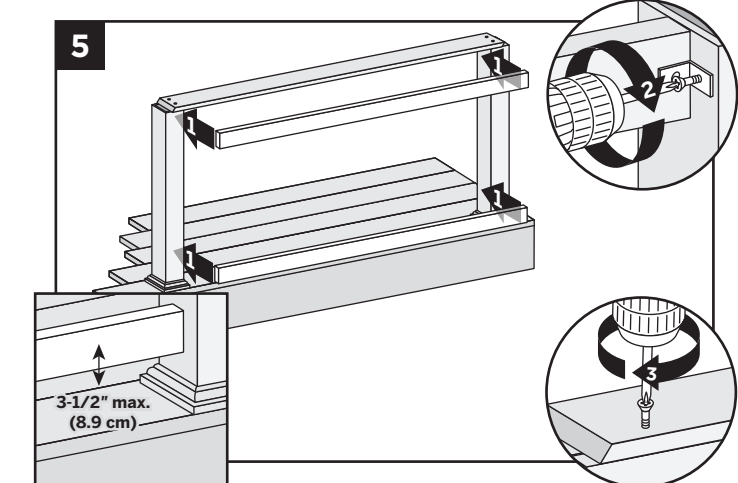

5. Center upper lateral rails under top rails to posts attaching with "L" brackets or equivalent construction method. (If toenailing screws into lateral railing, predrill these holes first to help prevent splitting and mushrooming of the screw.) Secure with 2-1/2" (6.4 cm) composite-approved screws and attach top rail to lateral rail with one screw every 12" (30.5 cm). Bottom rails attach with "L" brackets or equivalent construction method with 3-1/2" (8.9 cm) maximum clearance above deck surface.

HOW TO INSTALL RAISED RAILING/CONTINUED TREX® TRADITIONAL/OPTION 2

Installing Balusters

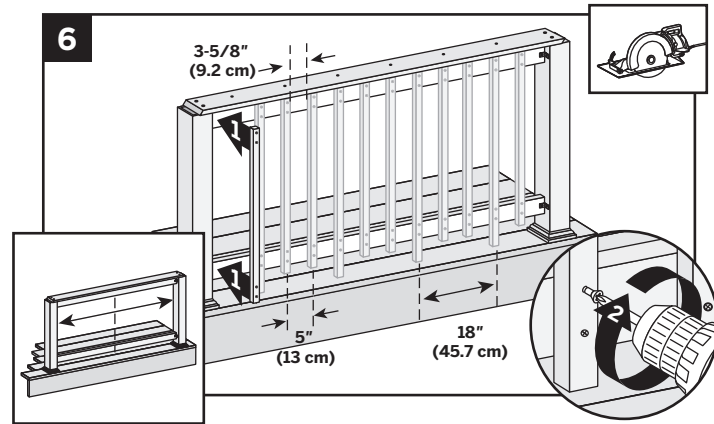

- Cut balusters to length, pre-drill two holes at top and bottom sides that will face outward on each baluster. Locate the center between posts, mark and place first baluster and secure with four 2-1/2" (6.4 cm) exterior-approved screws. Space balusters to the left and right a maximum of 3-5/8" (9.2 cm) edge-to-edge or 5" (13 cm) on center.
- One baluster must extend to decking surface every 18" (45.7 cm). Typically four per 6' (1.8 m) application.

HOW TO INSTALL STAIR RAILING TRADITIONAL ANCHORED AND TREX® TRADITIONAL RAISED/OPTION 1 AND OPTION 2

Installing Posts for Stair Railing

- In most cases, a railpost or post sleeve longer than 39" (99.1 cm) is required for the lower stair rail sections to accommodate stair angle. Both top and bottom posts need to be installed on outside corners (nose) of stair treads.

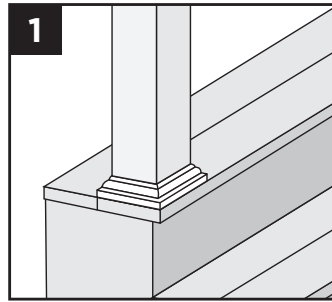

NOTE: Posts, post sleeve skirts, and post sleeves are installed per standard Traditional railing instructions. See pages 61 and 63.

Measuring and Cutting Railings

- Determine length and angle of top and lateral rails. Cut and install top rails per specific option chosen for Traditional railing.

NOTE: Allow a minimum clearance of 1" (2.5 cm) from stair treads.

Cut lateral rails to proper angle and install per specific option chosen for Traditional railing.

Cutting and Installing Balusters

- Cut balusters to proper length and install per specific option chosen for Traditional railing.

HOW TO INSTALL RAISED RAILING TREX® TRADITIONAL/OPTION 3

Rails BETWEEN Posts with CONTEMPORARY Balusters

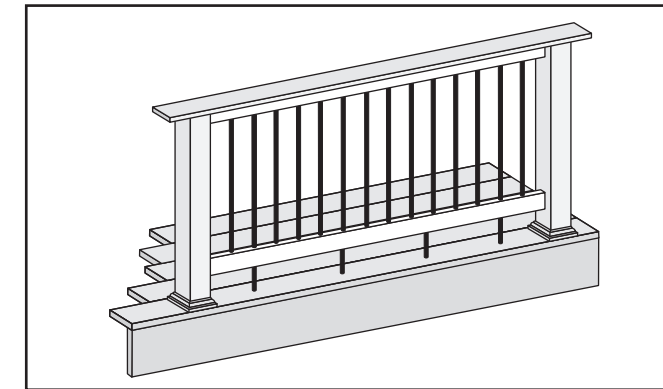

- Attaching Posts, Post Sleeve Skirts, and Post Sleeves** See instructions on pages 61 and 63.

Cutting Posts and Lateral Rails to Length

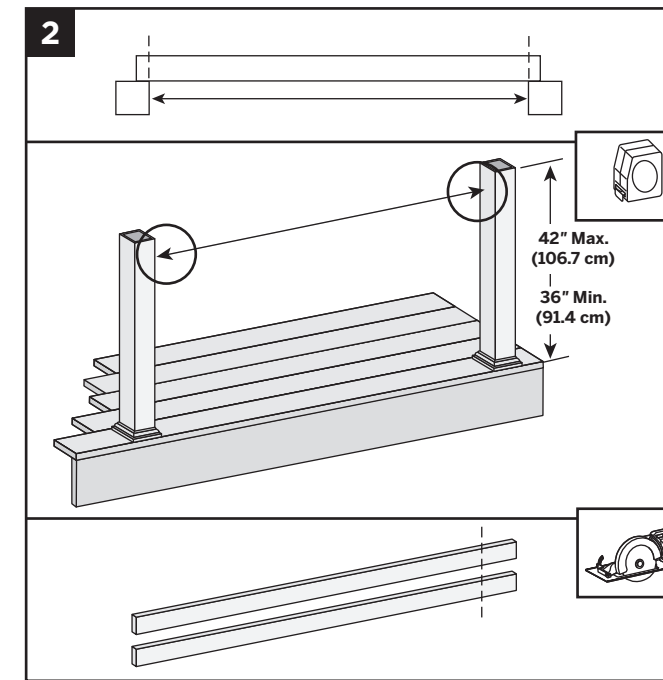

- Cut posts to length. Measure distance between inside edges of posts and cut two 2" x 4" (5.1 cm x 10.2 cm) lateral rails to fit. Leave 1/16" (0.15 cm) gap at each end for cold weather expansion.

Installing Foot Block

NOTE: This step is done **BEFORE** you attach the 2" x 4" (5.1 cm x 10.2 cm) bottom lateral rail to posts.

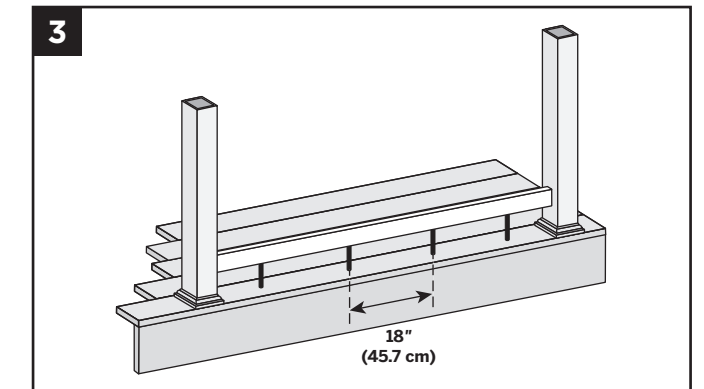

- Option 1:** Cut round balusters for foot blocks and place every 18" (45.7 cm). Secure in same method as balusters on lateral bottom rail and deck surface.

- Option 2:** Cut square balusters for foot blocks and place every 18" (45.7 cm) on lateral bottom rail. Toenail screws into foot blocks and bottom rail to secure.

Securing Bottom Lateral Rail

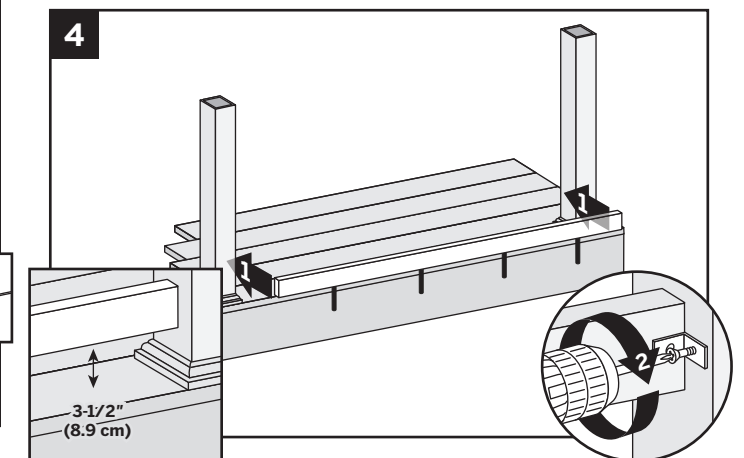

- Place bottom lateral rail between posts and attach using "L" brackets or equivalent construction method. Secure with 2-1/2" (6.4 cm) composite-approved screws.

HOW TO INSTALL RAISED RAILING/CONTINUED TREX® TRADITIONAL/OPTION 3

BALUSTER SIZE AND SPACING OPTIONS

For 36" (91.4 cm) rail height, use Trex 26" (66 cm) contemporary balusters. Part number: **BK3Q26RBK**

For 42" (106.7 cm) rail height, use Trex 32" (81.3 cm) contemporary balusters. Part number: **BK3Q32RBK**

Measure baluster spacing

Length of rail _____" ÷ 4.5 = _____ balusters

- » If number is odd, balusters will be centered.
- » If number is even, balusters will be offset 2-1/4" (5.7 cm) from center.

Installing Baluster Connectors

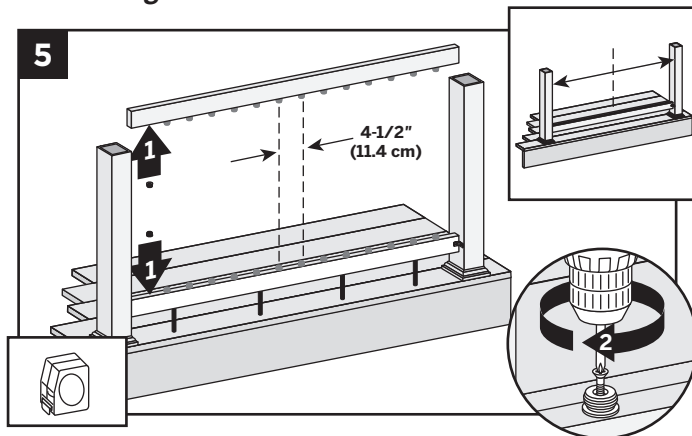

5. Mark center on top and bottom lateral rails and attach baluster connectors, 4-1/2" (11.4 cm) on center.

NOTE: Purchase level baluster connectors separately. Black 3/4" (1.9 cm) Horizontal Baluster Connectors are Part number: **BK075HCON**

Installing Balusters

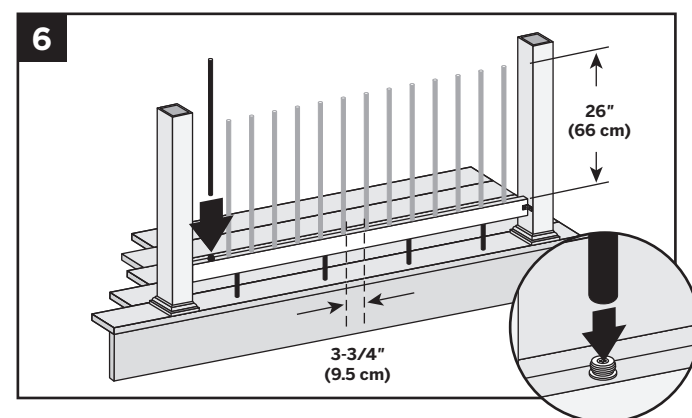

6. Insert balusters into connectors on bottom lateral rail.

Securing Upper Lateral Rail

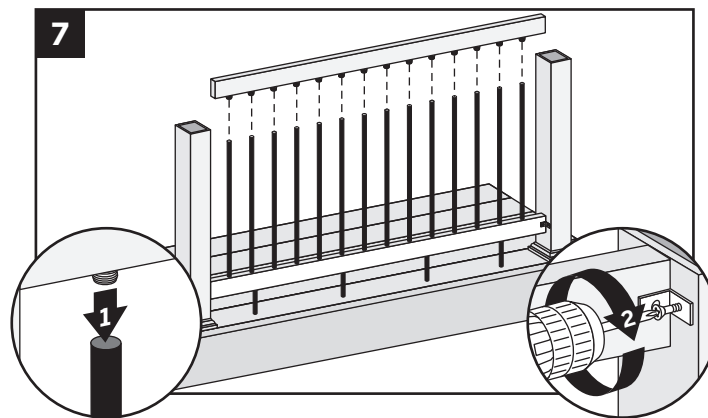

7. Position top lateral rail between posts and lower to insert balusters into connectors. Attach both ends to posts using "L" brackets or equivalent construction method. Secure with 2-1/2" (6.4 cm) composite-approved screws.

Installing Top Rail

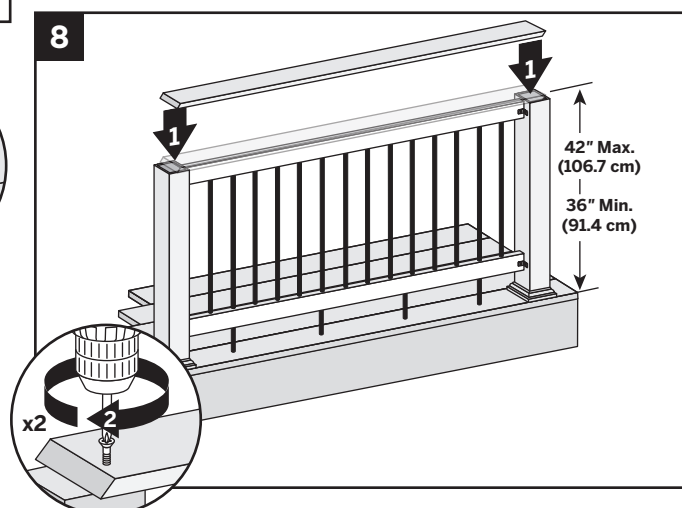

8. Measure distance between the posts from center-to-center.

Make scarf cuts on each end of deck board and use two exterior-approved screws per end to secure boards to posts with board centered over posts. Secure with 2-1/2" (6.4 cm) composite-approved screws every 12 inches.

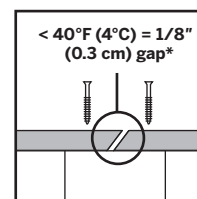

***NOTE:** If installing at below 40°F (4°C), leave 1/8" (0.3 cm) gap in scarf joints between boards.

HOW TO INSTALL RAISED STAIR RAILING TREX® TRADITIONAL/OPTION 3

Installing Stair Railing with Contemporary Balusters

BALUSTER OPTIONS AND CONNECTORS

For 36" (91.4 cm) rail height, use Trex 26" (66 cm) contemporary balusters. Part number: **BK3Q26RBK**

For 42" (106.7 cm) rail height, use Trex 32" (81.3 cm) contemporary balusters. Part number: **BK3Q32RBK**

Black 3/4" (1.9 cm) stair baluster connectors
Part number: **BK075SCON**

Measure baluster spacing

Length of rail _____" ÷ 5.5 = _____ balusters

- » If number is odd, balusters will be centered.
- » If number is even, balusters will be offset 2-3/4" (7 cm) from center.

1. Installing Posts for Stair Railing

See instructions on page 64.

Cutting Lateral Rails and Measuring Baluster Spacing

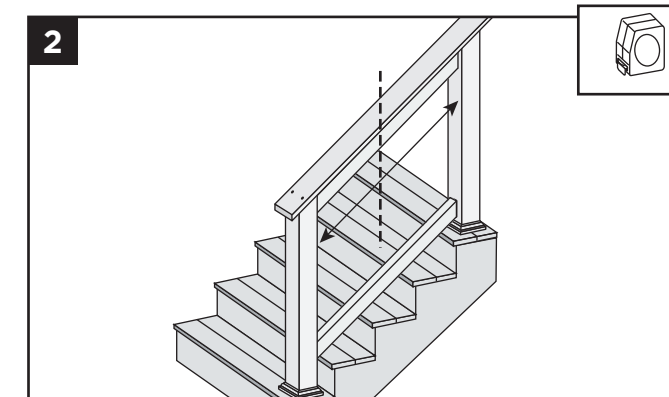

2. Cut top and bottom rails the distance between posts and determine angle of end cuts and mark centers. Use equation (above) to determine number of balusters needed.

Installing Foot Blocks

NOTE: This step is done **BEFORE** you attach the 2" x 4" (5.1 cm x 10.2 cm) bottom lateral rail to posts.

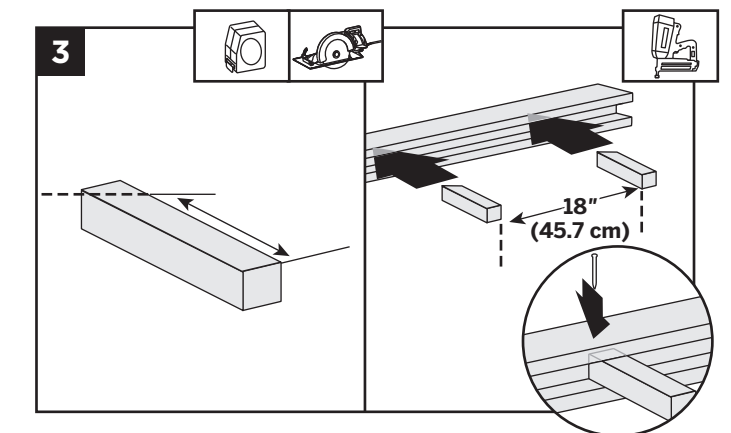

2. **Option 1:** Cut square balusters for foot blocks and place every 18" (45.7 cm) on lateral bottom rail. Toenail screws into foot blocks and bottom rail to secure.

Option 2: Cut round balusters for foot blocks and place every 18" (45.7 cm). Secure in same method as balusters on lateral bottom rail and deck surface.

Installing Baluster Connectors

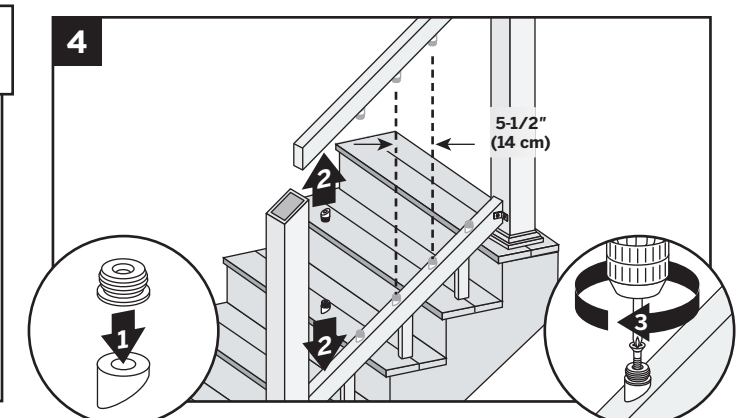

4. Install stair baluster connectors and adaptors to top and bottom rails, 5-1/2" (14 cm) on center.

NOTE: Black 3/4" (1.9 cm) stair baluster connectors are sold separately. Part number **BK075SCON**

HOW TO INSTALL RAISED STAIR RAILING/CONTINUED TREX® TRADITIONAL/OPTION 3

Securing Bottom Lateral Rail

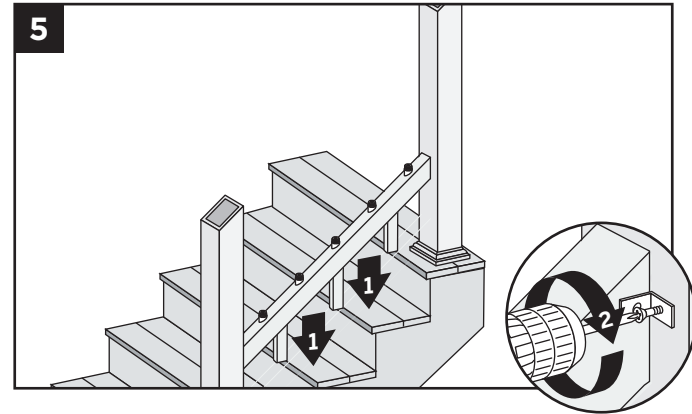

5. Place bottom lateral rail between posts and attach using "L" brackets or equivalent construction method. Secure with 2-1/2" (6.4 cm) composite-approved screws.

Installing Balusters and Top Lateral Rail

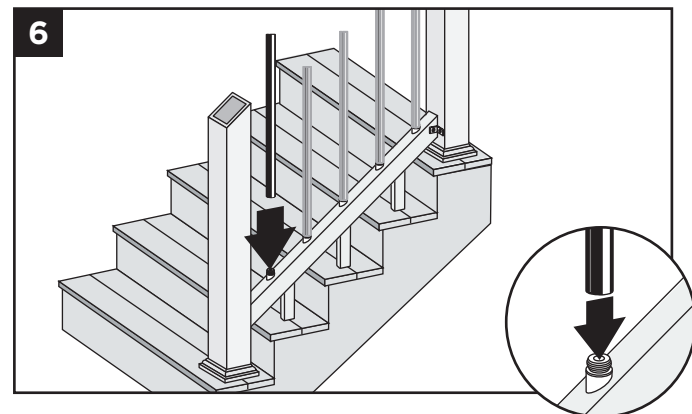

6. Insert end of balusters into adapters on bottom rail.

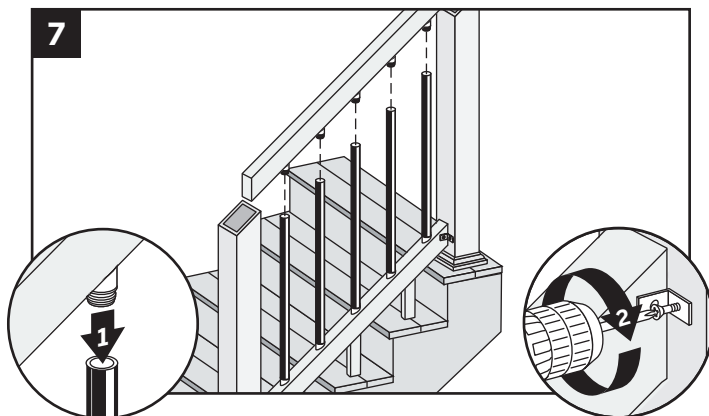

7. Insert end of balusters to adapters on top lateral rail and connect rail to posts with "L" brackets or equivalent construction methods.

Installing Top Hand Rail

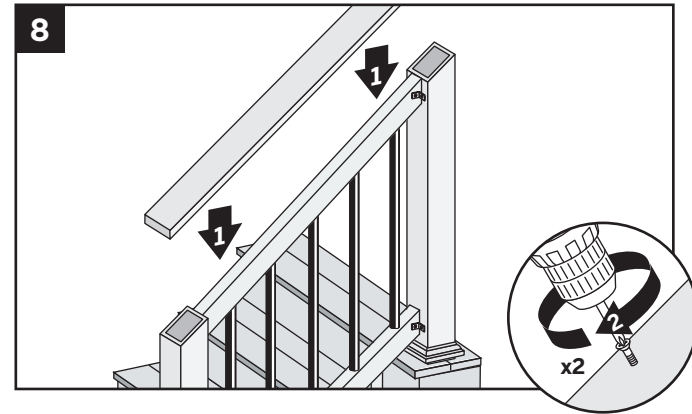

8. Center deck board across top of posts and attach using two exterior-approved screws positioned laterally on both ends. Secure with 2-1/2" (6.4 cm) composite-approved screws every 12 inches.

HOW TO INSTALL RAISED RAILING TREX® TRADITIONAL/OPTION 4

Rails BETWEEN Posts with ARCHITECTURAL Balusters

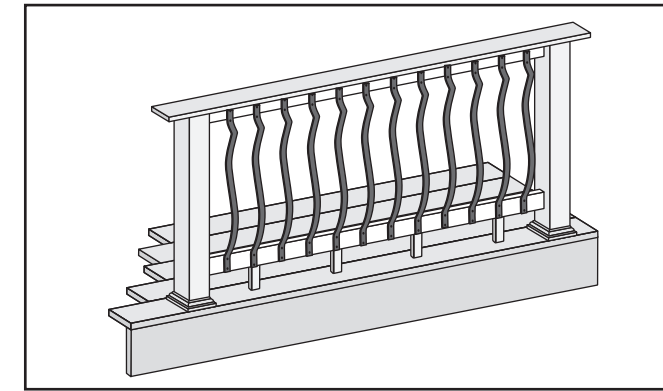

1. **Attaching Posts, Post Sleeve Skirts, and Post Sleeves** See instructions on pages 61 and 63.

Cutting Posts to Length and Installing Top Rail

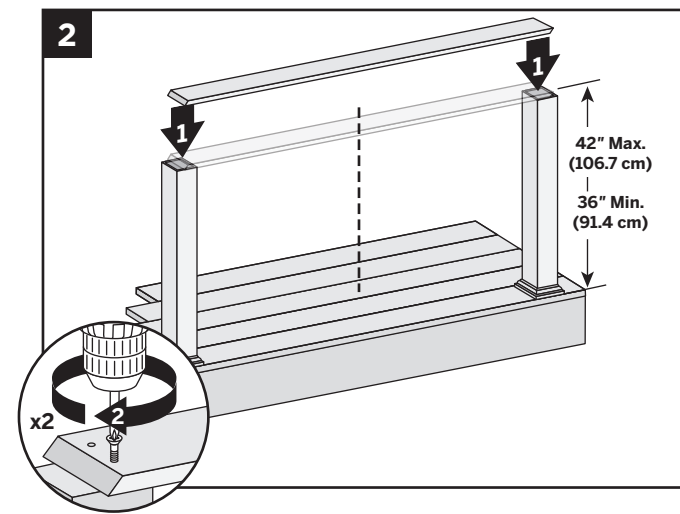

2. Cut posts to length. Measure distance between posts from center-to-center.

Make scarf cuts on each end of deck board and use two exterior-approved screws per end to secure boards to posts with board centered over posts.

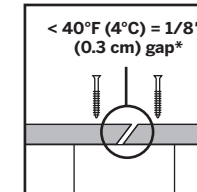

***NOTE:** If installing below 40°F (4°C) leave 1/8" (0.3 cm) gap between deck boards for thermal expansion.

Cutting Lateral Rail

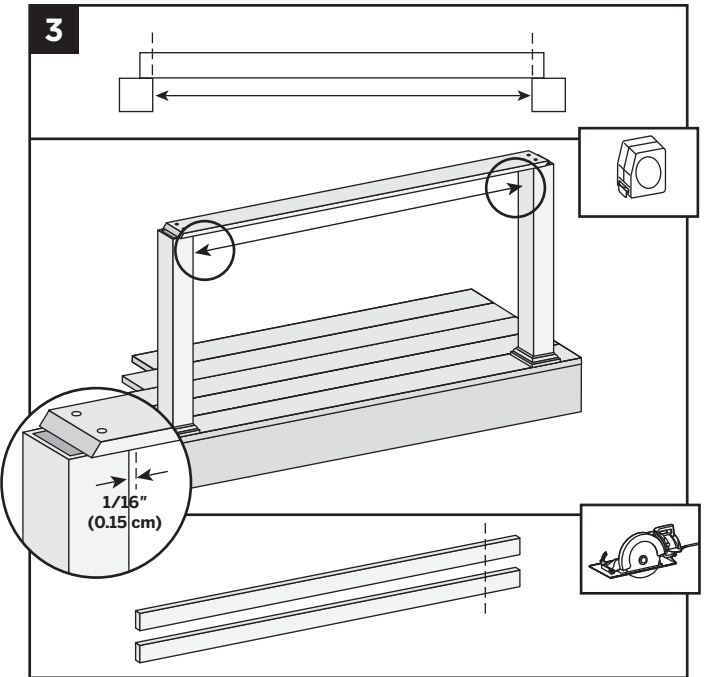

3. Measure distance between inside edges of posts and cut two 2" x 4" (5.1 cm x 10.2 cm) lateral rails to fit. Leave 1/16" (0.15 cm) gap at each end for cold weather expansion.

Installing Foot Blocks

NOTE: For ease of installation of foot blocks, install **BEFORE** attaching the bottom rail to the post.

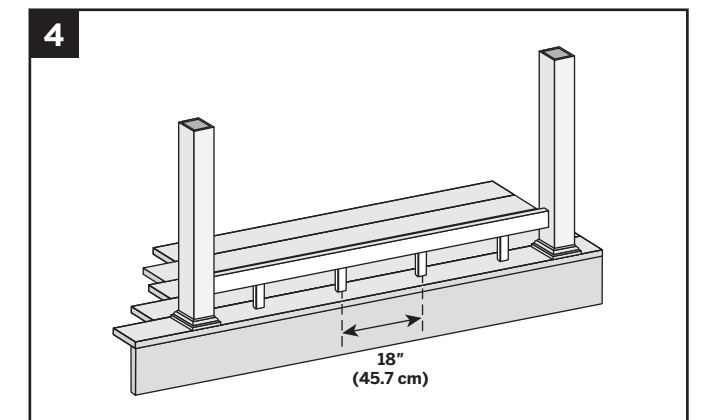

4. Cut square balusters to fit under bottom lateral rail and locate every 18" (45.7 cm). Toenail screws into foot blocks and bottom rail to secure.

HOW TO INSTALL RAISED RAILING/CONTINUED TREX® TRADITIONAL/OPTION 4

Attaching Lateral Rail with L-Brackets

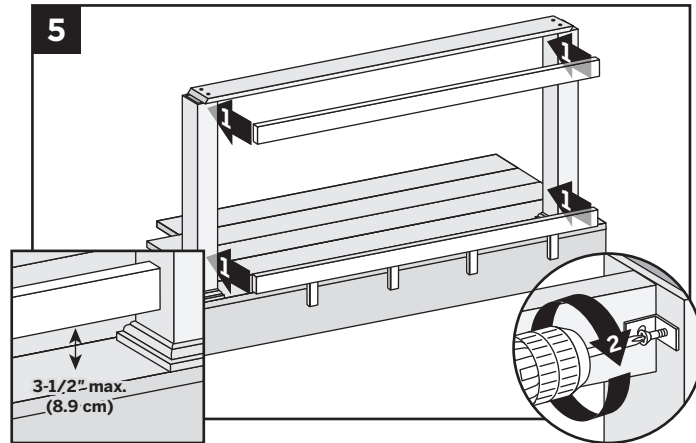

5. Center lateral rail under top rail and attach to posts using an "L" bracket or equivalent construction method. Secure with 2-1/2" (6.4 cm) composite-approved screws and attach top rail with one screw every 12" (30.5 cm).

BALUSTER SIZE AND SPACING OPTIONS

For 36" (91.4 cm) rail height, use Trex 32-1/4" (81.9 cm) architectural balusters. Total height from top rail to deck surface is 35-1/4" (89.5 cm). Part number: **BK0132VBK**

For 42" (106.7 cm) rail height, use Trex 40" (101.6 cm) architectural balusters. Total height from top rail to deck surface is 40" (101.6 cm). Part number: **BK0140VBK**

Measure baluster spacing

Length of rail _____" ÷ 4.5 = _____ balusters

- » If number is odd, balusters will be centered.
- » If number is even, balusters will be offset 2-1/4" (5.7 cm) from center.

Installing Balusters

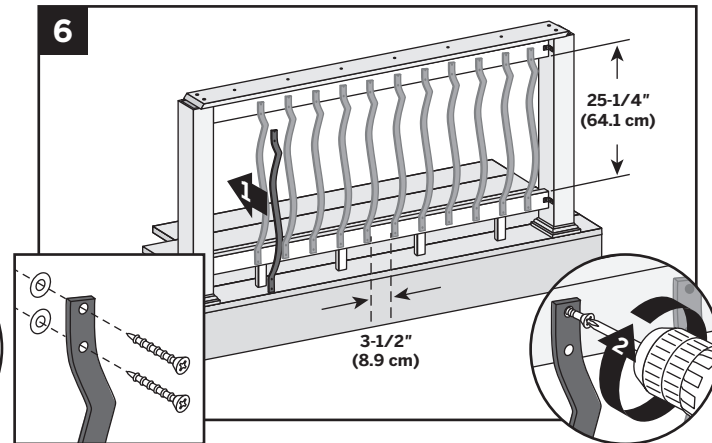

6. Locate the center between posts, mark and place first baluster and secure with four 2-1/2" (6.4 cm) exterior-approved screws. Space balusters to the left and right a maximum of 3-1/2" (8.9 cm) edge-to-edge.

NOTE: A 2" x 4" (5.1 cm x 10.2 cm) can be used for spacing architectural balusters.

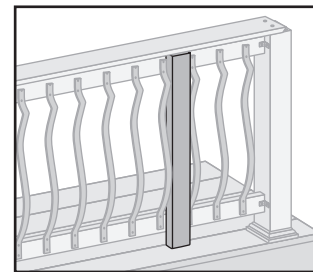

HOW TO INSTALL RAISED STAIR RAILING TREX® TRADITIONAL/OPTION 4

Installing Stair Railing with Architectural Balusters

BALUSTER OPTIONS AND CONNECTORS

For 36" (91.5 cm) rail height, use Trex 32" (81.3 cm) architectural balusters. Part number: **BK0132VBK**

For 42" (106.7 cm) rail height, use Trex 40" (101.6 cm) architectural balusters. Part number: **BK0140VBK**

Measure baluster spacing

Length of rail _____" ÷ 5.5 = _____ balusters

- » If number is odd, balusters will be centered.
- » If number is even, balusters will be offset 2-3/4" (7 cm) from center.

1. **Installing Posts for Stair Railing**
See instructions on page 64.

Cutting Lateral Rails and Measuring Baluster Spacing

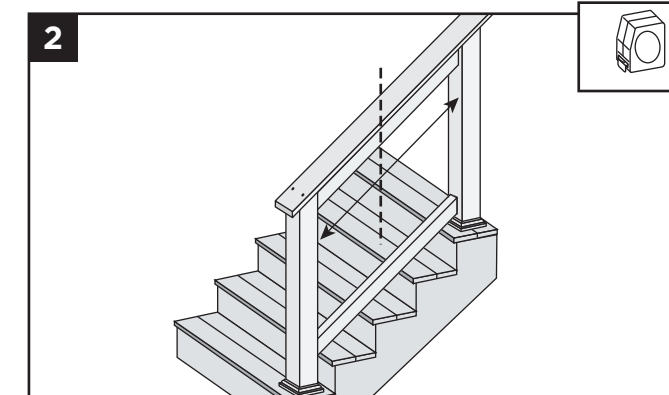

2. Cut top and bottom rails the distance between posts and determine angle of end cuts and mark centers. Use equation (above) to determine number of balusters needed.

Installing Foot Blocks

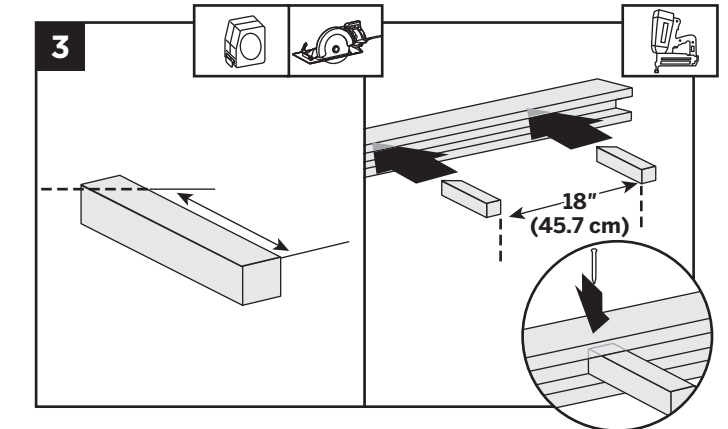

3. Cut square balusters for foot blocks and place every 18" (45.7 cm) on lateral bottom rail. Toenail screws into foot blocks and bottom rail to secure.

Installing Top and Bottom Lateral Rail

4. Connect rails to posts with "L" brackets or equivalent construction methods.

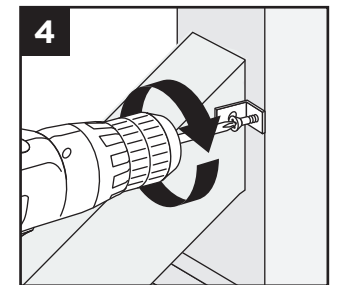

Installing Balusters

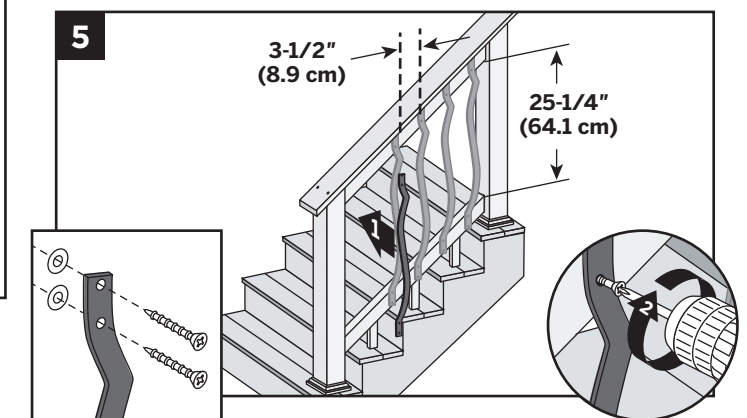

5. Measure distance between posts to determine center point of top and bottom rails. Install first baluster with four 2-1/2" (6.4 cm) exterior-approved screws. Space balusters a maximum of 3-1/2" (8.9 cm) edge-to-edge.

NOTE: A 2" x 4" (5.1 cm x 10.2 cm) can be used for spacing the architectural balusters.

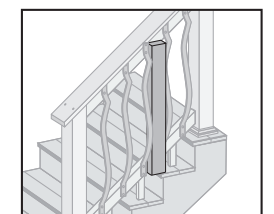

TREX® ADA RAILING

Stair Application



Horizontal Application

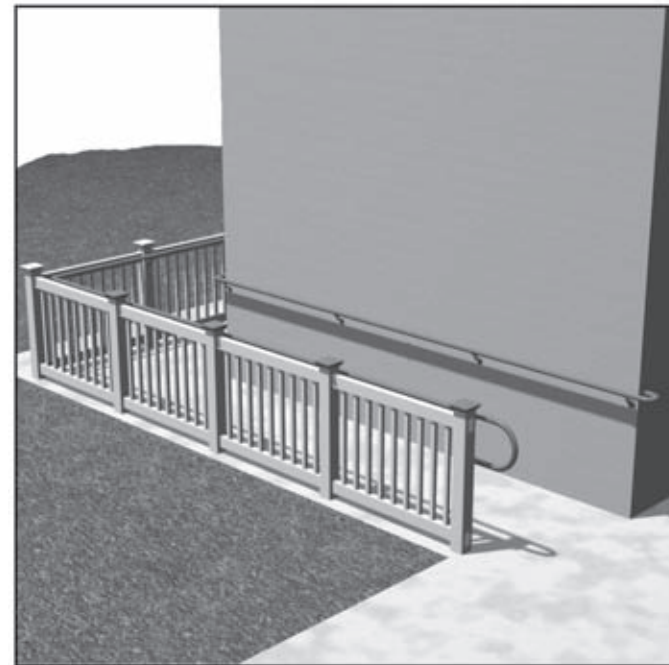

ADA Handrail Guidelines

1. You can install ADA handrails using various design applications such as those for stairs, ramps, and horizontal inclines. Designs include options for straight and 90° wall returns, 90° corners, and adjustable angles. Choose which is best for your needs before installing.
2. The handrail system top rail should be 34" (86.4 cm) to 39" (99.1 cm) above the surface. However, verifying height requirements with local building code officials before installing is important as codes vary in different areas.
3. Maintain a minimum clearance of 1-1/2" (3.8 cm) between the handrail and any obstructions above or behind the handrail.
4. The end loop return at all landings must extend 12" (30.5 cm) past the end of the ramp or stair application.
5. The slope of the handrail for the ramp should not exceed 1" (2.5 cm) rise over a 12" (30.5 cm) run.
6. The maximum recommended span between supports is 6' (1.83 m) on center.
7. For ramps and stairs, cut railings along with the end loops and/or post returns to the proper angle using a miter saw to ensure proper fit.

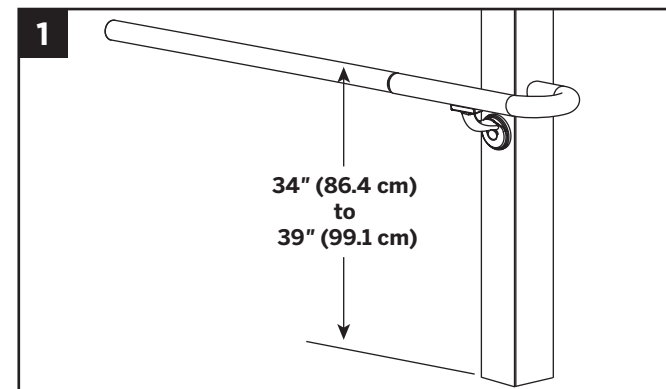

HOW TO INSTALL TREX® ADA RAILING

90° Wall Return

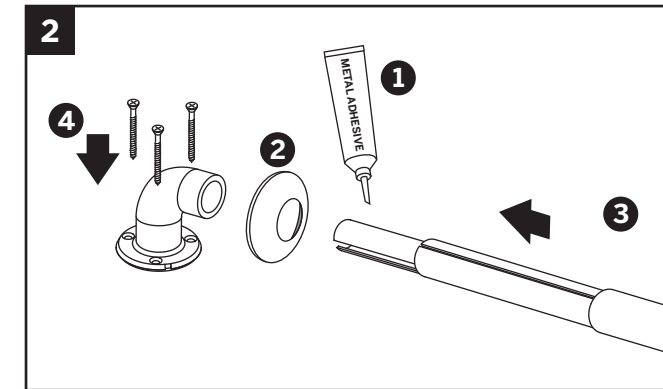

Cut the aluminum and PVC tube to proper length.

1. Apply adhesive to all metal contact surfaces.
2. Make sure flange cover is placed over PVC rail prior to assembly.
3. Slide straight joiner into wall return and aluminum rail support.
4. Attach mounting flange to desired surface. Snap flange cover into place.

NOTE: Hardware not included.

Straight Wall Return

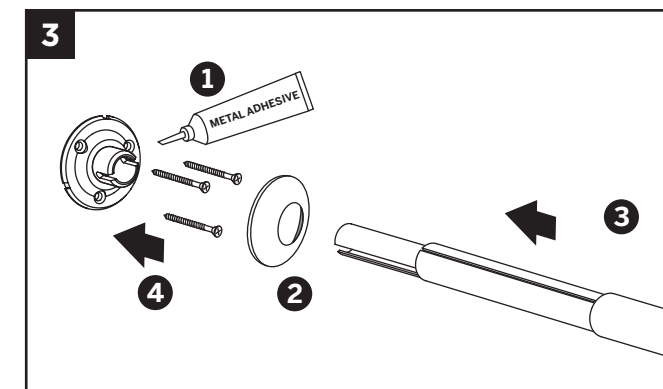

Cut the aluminum and PVC tube to proper length.

1. Apply adhesive to all metal contact surfaces.
2. Make sure flange cover is placed over PVC rail prior to assembly.
3. Insert straight wall return into aluminum rail support.
4. Attach mounting flange to desired surface. Snap flange cover into place.

NOTE: Hardware not included.

NOTE: A PVC adhesive may be used to ensure a tight seam on the exterior tube. Make sure adhesive cures per manufacturer's instructions.

Handrail Bracket

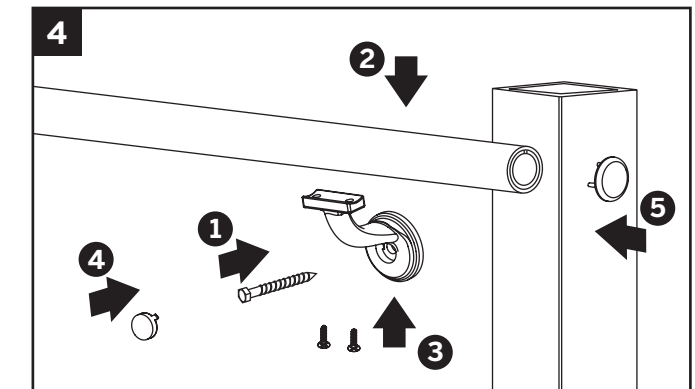

1. Pre-drill hole using 1/4" (0.6 cm) bit and attach bracket to mounting surface using an appropriate connector (a 3/8" (1 cm) lag bolt at least 2" (5.1 cm) long should be used when mounting to a wood surface).

NOTE: Lag bolt is not included.

2. Place the rail at appropriate location on bracket.
3. Pre-drill two holes in the rail with an 11/64" (0.4 cm) drill bit at appropriate location and attach with screws (provided).
4. Snap bolt cover into place.
5. Using PVC adhesive, attach handrail end cap (sold separately) to unfinished end of rail.

90° Corner

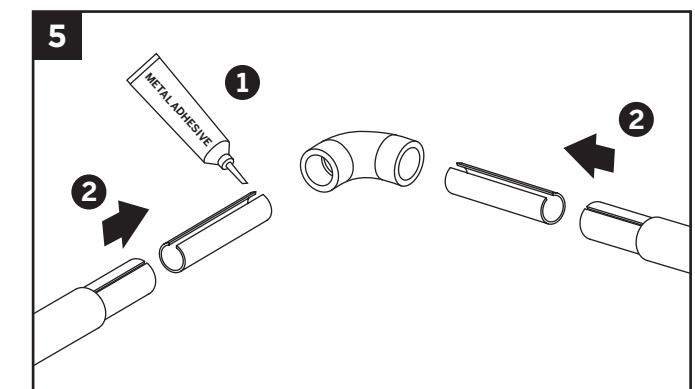

Cut the aluminum and PVC tube to proper length.

1. Apply adhesive to all metal contact surfaces.
2. Slide straight joiner into each side of corner and aluminum rail supports.

HOW TO INSTALL TREX® ADA RAILING

End Loop - Horizontal

18" x 12" x 18" (45.7 cm x 30.5 cm x 45.7 cm)

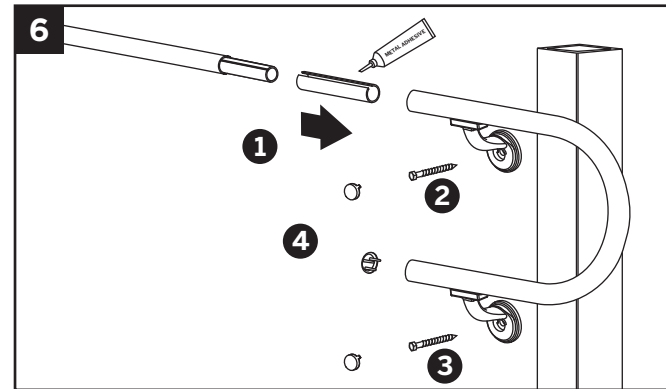

1. Apply adhesive to all metal contact surfaces. Slide straight joiner into end loop and aluminum rail support.
2. Pre-drill holes using 1/4" (0.6 cm) drill bit and attach top bracket to mounting surface using an appropriate connector (a 3/8" (1 cm) lag bolt at least 2" (5.1 cm) long should be used when mounting to a wood surface).
3. Attach bottom bracket in the same manner. Place end loop in appropriate location on bracket. Pre-drill four holes in end loop with an 11/64" (0.4 cm) drill bit at appropriate location and attach with screws (provided). Snap bolt covers into place.
4. Using PVC adhesive, attach hand rail end cap (sold separately) to unfinished end of rail.

End Loop - Angled

18" x 12" x 18" (45.7 cm x 30.5 cm x 45.7 cm)

NOTE: Rail and end loop must be cut to appropriate angles before installing.

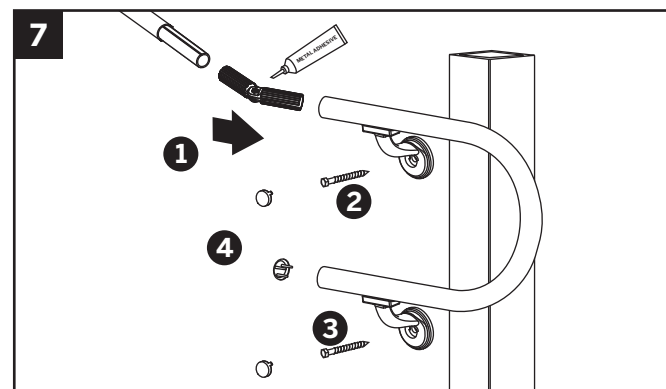

1. Apply adhesive to all metal contact surfaces. Slide adjustable joiner into end loop and aluminum rail support. Make sure adjustable joiner is plumb.

2. Pre-drill holes using 1/4" (0.6 cm) drill bit and attach top bracket to mounting surface using an appropriate connector (a 3/8" (1 cm) lag bolt at least 2" (5.1 cm) long should be used when mounting to a wood surface).
3. Attach bottom bracket in the same manner. Place end loop in appropriate location on bracket. Pre-drill four holes in end loop with an 11/64" (0.4 cm) drill bit at appropriate location and attach with screws (provided). Snap bolt covers into place.
4. Using PVC adhesive, attach hand rail end cap (sold separately) to unfinished end of rail.

Post Return - Horizontal

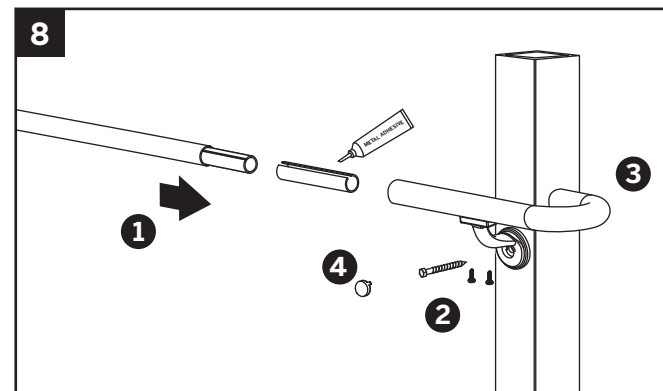

1. Apply adhesive to all metal contact surfaces. Slide straight joiner into post return and aluminum rail support.
2. Pre-drill holes using 1/4" (0.6 cm) drill bit and attach bracket to mounting surface using an appropriate connector (a 3/8" (1 cm) lag bolt at least 2" (5.1 cm) long should be used when mounting to a wood surface).
3. Place post return at appropriate location on bracket. Pre-drill two holes in post return with an 11/64" (0.4 cm) drill bit at appropriate location and attach with screws (provided).
4. Snap bolt covers into place.

HOW TO INSTALL TREX® ADA RAILING

Post Return - Angled

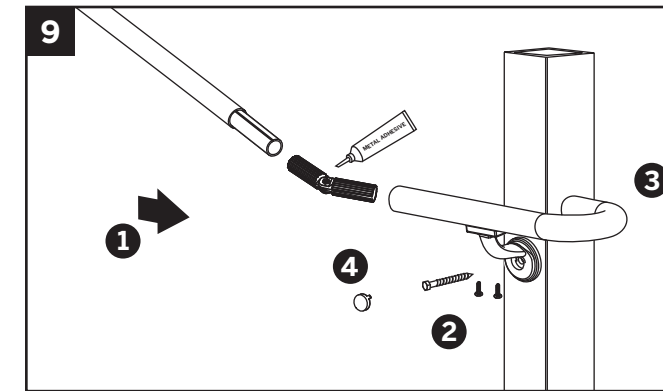

1. Apply adhesive to all metal contact surfaces. Slide adjustable joiner into post return and aluminum rail support. Make sure adjustable joiner is plumb.
2. Pre-drill holes using 1/4" (0.6 cm) drill bit and attach bracket to mounting surface using an appropriate connector (a 3/8" (1 cm) lag bolt at least 2" (5.1 cm) long should be used when mounting to a wood surface).
3. Place post return at appropriate location on bracket. Pre-drill two holes in post return with an 11/64" (0.4 cm) drill bit at appropriate location and attach with screws (provided).
4. Snap bolt cover into place.

Straight Joiner

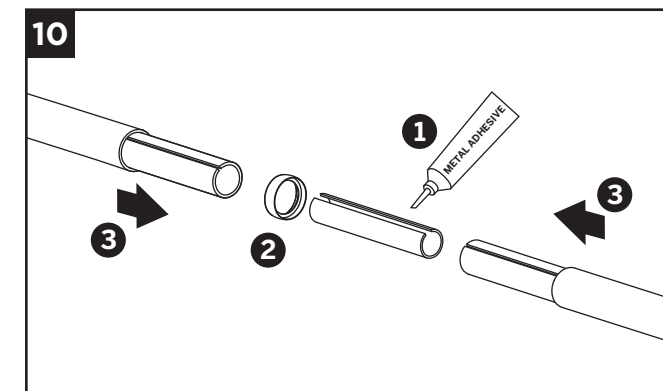

1. Apply adhesive to all metal contact surfaces.
2. **Optional:** Position joint ring between rail sections.
3. Slide joiner into both aluminum rail supports until the joint is tight.

Angled Corner

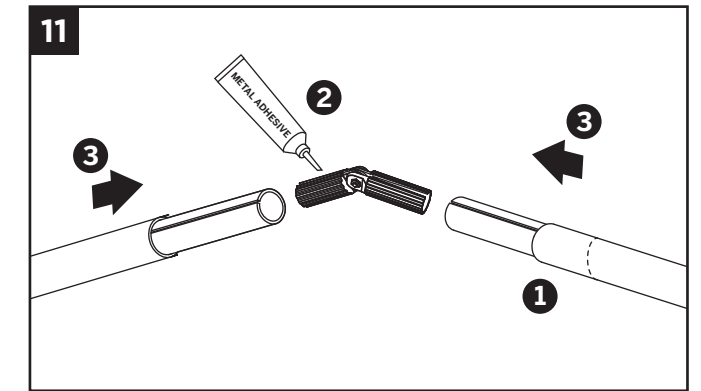

1. Cut the aluminum and PVC tube to proper length at desired angle.
2. Apply adhesive to all metal contact surfaces.
3. Slide rails together until the adjustable joint is tight.

NOTE: A PVC adhesive may be used to ensure a tight seam on the exterior tube. Make sure adhesive cures per manufacturer's instructions.

NOTE: A PVC adhesive may be used to ensure a tight seam on the exterior tube. Make sure adhesive cures per manufacturer's instructions.

WARRANTIES

TREX TRANSCEND® 25-YEAR LIMITED RESIDENTIAL FADE AND STAIN WARRANTY

For a period of twenty-five (25) years from the date of original purchase, Trex Company, Inc. (hereinafter "Trex") warrants to the original end-user residential purchaser (the "Purchaser") that Trex Transcend® decking (the "Product") will perform, under normal residential use and service conditions, as follows:

Fade Resistance: The Product shall not fade in color from light and weathering exposure as measured by color change of more than 5 Delta E (CIE) units.

The Product is designed to resist fading. No material is fade proof when exposed to years of UV exposure and the elements. The Product is designed to resist fading, and will not in any event fade by more than 5 Delta E (CIE) units.

Stain Resistance: The Product shall be resistant to permanent staining resulting from spills of food and beverage items including ketchup, mustard, salad oils, tea, wine, coffee, fruit punch, barbecue sauce, grease, sodas and other food and beverage related items that would typically be present on a residential deck, or mold and mildew naturally occurring in the environment, provided that such substances are removed from the Product with soap and water or mild household cleaners after no more than one (1) week of exposure of the food or beverage to the surface or first appearance of the mold and mildew.

Notwithstanding the foregoing, Trex does not warrant that the Product is stainproof, and does not warrant stain resistance resulting from spilled or otherwise applied food and beverage substances which are not properly cleaned as provided above within one (1) week of exposure. In addition, materials not covered in the stain resistant warranty include abrasive compounds of acidic or basic pH, paints or stains, strong solvents, metallic rust or other abnormal residential deck use items, and non-food and non-beverage substances, including but not limited to, biocides, fungicides, plant food, or bactericides. Mold and mildew can settle and grow on any outdoor surface, including this Product. You should periodically clean your deck to remove dirt and pollen that can feed mold and mildew. This warranty does not cover mold and mildew which is not properly cleaned as provided above within one (1) week of first appearance.

Residential Purchaser: For purposes of this warranty, a "residential purchaser" shall refer to an individual residential homeowner.

Standard Trex Company Limited Residential Warranty: This warranty is in addition to the standard Trex Company Limited Residential Warranty that applies to all Trex products.

Transferability: This warranty may be transferred one (1) time, within the five (5) year period beginning from the date of original purchase by the Purchaser, to a subsequent buyer of the property upon which the Product was originally installed.

Exclusions from Warranty Coverage:

Exposure to Heat: Direct or indirect contact with extreme heat sources (over 250 degrees) or may cause fading and may damage the surface of the Product, and any effects of such exposure are expressly excluded from coverage under this warranty.

Surface Damage: Never use metal shovels or sharp-edged tools to remove snow and ice on the surface of the Product. If the surface of the Product is damaged or punctured, this warranty will be voided.

Paint Or Other Materials Applied to Trex Transcend Decking: If paint or other coating materials are applied to the Product, this warranty will be voided.

Railing: This warranty does not cover Trex Transcend railing components.

Other Exclusions: This warranty shall not cover any condition attributable to: (1) improper installation of the Product and/or failure to abide by Trex's installation guidelines, including but not limited to improper gapping; (2) use of the Product beyond normal residential use, or in an application not recommended by Trex's guidelines and local building codes; (3) movement, distortion, collapse or settling of the ground or the supporting structure on which the Product is installed; (4) any act of God (such as flooding, hurricane, earthquake, lightning, etc.), (5) improper handling, storage, abuse or neglect of the Product by Purchaser, the transferee or third parties, (6) any fading or staining not on the walking surface of the Product (i.e., the underside or the ends of the Product); or (7) ordinary wear and tear. *(continued next page)*

Procedure for Making a Claim under This Warranty

In order to make a claim under this warranty, Purchaser must do the following:

1. If the Purchaser is making a claim relating to the warranty on stain resistance, Purchaser must do as follows:
 - (a) Purchaser must try to clean the affected area of the deck by using the cleaning procedures described under Care and Cleaning Guide within one (1) week of exposure of the food or beverage to the Product or first appearance of the mold and mildew.
 - (b) If the affected area remains reasonably unsatisfactory after Purchaser has tried these cleaning procedures, then Purchaser must have the affected area of the deck professionally cleaned at Purchaser's expense.
 - (c) If the affected area remains reasonably unsatisfactory after the professional cleaning, Purchaser may make a claim under this warranty, provided that such claim is made within thirty (30) days after the professional cleaning.
2. To make a claim under this limited warranty, Purchaser, or the transferee, shall send to Trex, within the warranty period (25 years after date of original purchase), a description and photographs of the affected area of the Product, proof of purchase, and if the claim relates to the warranty on stain resistance, proof of compliance with paragraph 1 above, to the following address:

Trex Company, Inc.
Customer Relations
160 Exeter Drive
Winchester, VA 22603-8605
3. Upon confirmation by an authorized Trex representative of a valid claim hereunder, Trex's sole responsibility shall be, at its option, to either replace the affected item or refund the portion of the purchase price paid by Purchaser for such affected item (not including the cost of its initial installation). Replacement material will be provided that is as close as possible in color, design and quality as the replaced material, but Trex does not guarantee an exact match as colors and design may change.
4. If a valid warranty claim hereunder is made during years eleven (11) through twenty-five (25) after the original purchase, recovery will be prorated. If Trex is providing replacement materials, it may elect to replace the percentage listed below of boards otherwise meeting the requirements for a claim, or if it is refunding the purchase price, it may elect to refund the percentage listed below of the purchase price of boards otherwise meeting the requirements for a claim.

Year of Warranty Claim	Percentage Recovery
11	80%
12	80%
13	80%
14	60%
15	60%
16	60%
17	40%
18	40%

Year of Warranty Claim	Percentage Recovery
19	40%
20	20%
21	20%
22	20%
23	10%
24	10%
25	10%

5. This warranty shall not cover and Trex shall not be responsible for costs and expenses incurred with respect to the removal of affected Product or the installation of replacement materials, including but not limited to labor and freight.

Under no circumstances will Trex be liable for special, incidental or consequential damages, whether such damages are sought in contract, in tort (including but not limited to negligence and strict liability) or otherwise, and Trex's liability with respect to Products shall in no event exceed the replacement of such products or refund of the purchase price, as described above.

Some states do not allow the exclusion or limitation of incidental or consequential damages, so the above limitation or exclusion may not apply to you. This warranty gives you specific legal rights, and you may also have other rights that vary from state to state.

This warranty shall only be applicable and enforceable in the United States of America and Canada.

TREX TRANSCEND® 10-YEAR LIMITED COMMERCIAL FADE AND STAIN WARRANTY

For a period of ten (10) years from the date of original purchase, Trex Company, Inc. (hereinafter "Trex") warrants to the original end-user commercial purchaser (the "Purchaser") that Trex Transcend® decking (the "Product") will perform, under normal commercial use and service conditions, as follows:

Fade Resistance: The Product shall not fade in color from light and weathering exposure as measured by color change of more than 5 Delta E (CIE) units.

The Product is designed to resist fading. No material is fade proof when exposed to years of UV exposure and the elements. The Product is designed to resist fading and will not in any event fade by more than 5 Delta E (CIE) units.

Stain Resistance: The Product shall be resistant to permanent staining resulting from spills of food and beverage items including ketchup, mustard, salad oils, tea, wine, coffee, fruit punch, barbeque sauce, grease, sodas and other food and beverage related items that would typically be present on a deck, or mold and mildew naturally occurring in the environment, provided that such substances are removed from the Product with soap and water or mild household cleaners after no more than one (1) week of exposure of the food or beverage to the surface or first appearance of the mold and mildew.

Notwithstanding the foregoing, Trex does not warrant that the Product is stain-proof, and does not warrant stain resistance resulting from spilled or otherwise applied food and beverage substances which are not properly cleaned as provided above within one (1) week of exposure. In addition, materials not covered in the stain resistant warranty include abrasive compounds of acidic or basic pH, paints or stains, strong solvents, metallic rust or other abnormal commercial deck use items, and non-food and non-beverage substances, including but not limited to, biocides, fungicides, plant food, or bactericides. Mold and mildew can settle and grow on any outdoor surface, including this Product. You should periodically clean your deck to remove dirt and pollen that can feed mold and mildew. This warranty does not cover mold and mildew that is not properly cleaned as provided above within one (1) week of first appearance.

Commercial Purchaser: For purposes of this warranty, a "commercial purchaser" shall refer to any purchaser other than an individual residential homeowner.

Standard Trex Company Limited Commercial Warranty: This warranty is in addition to the standard Trex Company Limited Commercial Warranty that applies to all Trex products.

Transferability: This warranty may be transferred to subsequent buyers of the property upon which the Product was originally installed.

Exclusions from Warranty Coverage:

Exposure to Heat: Direct or indirect contact with extreme heat sources (over 250 degrees) may cause fading and may damage the surface of the Product, and any effects of such exposure are expressly excluded from coverage under this warranty.

Surface Damage: Never use metal shovels or sharp-edged tools to remove snow and ice on the surface of the Product. If the surface of the Product is damaged or punctured, this warranty will be voided.

Paint Or Other Materials Applied to Trex Transcend Decking: If paint or other coating materials are applied to the Product, this warranty will be voided.

Railing: This warranty does not cover Trex Transcend railing components.

Other Exclusions: This warranty shall not cover any condition attributable to: (1) improper installation of the Product and/or failure to abide by Trex's installation guidelines, including but not limited to improper gapping; (2) use of the Product beyond normal commercial use, or in an application not recommended by Trex's guidelines and local building codes; (3) movement, distortion, collapse or settling of the ground or the supporting structure on which the Product is installed; (4) any act of God (such as flooding, hurricane, earthquake, lightning, etc.); (5) improper handling, storage, abuse or neglect of the Product by Purchaser, any transferee or third parties; (6) any fading or staining not on the walking surface of the Product (i.e., the underside or the ends of the Product); or (7) ordinary wear and tear. *(continued next page)*



Procedure for Making a Claim under this Warranty

In order to make a claim under this warranty, Purchaser must do the following:

1. If the Purchaser is making a claim relating to the warranty on stain resistance, Purchaser must do as follows:
 - (a) Purchaser must try to clean the affected area of the deck by using the cleaning procedures described under Care and Cleaning Guide within one (1) week of exposure of the food or beverage to the Product or first appearance of the mold and mildew.
 - (b) If the affected area remains reasonably unsatisfactory after Purchaser has tried these cleaning procedures, then Purchaser must have the affected area of the deck professionally cleaned at Purchaser's expense.
 - (c) If the affected area remains reasonably unsatisfactory after the professional cleaning, Purchaser may make a claim under this warranty, provided that such claim is made within thirty (30) days after the professional cleaning.
2. To make a claim under this limited warranty, Purchaser, or the transferee, shall send to Trex, within the warranty period (10 years after date of original purchase), a description and photographs of the affected area of the Product, proof of purchase, and if the claim relates to the warranty on stain resistance, proof of compliance with paragraph 1 above, to the following address:

Trex Company, Inc.
Customer Relations
160 Exeter Drive
Winchester, VA 22603-8605

3. Upon confirmation by an authorized Trex representative of a valid claim hereunder, Trex's sole responsibility shall be, at its option, to either replace the affected item or refund the portion of the purchase price paid by Purchaser for such affected item (not including the cost of its initial installation). Replacement material will be provided that is as close as possible in color, design and quality as the replaced material, but Trex does not guarantee an exact match as colors and design may change.

4. This warranty shall not cover and Trex shall not be responsible for costs and expenses incurred with respect to the removal of affected Product or the installation of replacement materials, including but not limited to labor and freight.

Under no circumstances will Trex be liable for special, incidental or consequential damages, whether such damages are sought in contract, in tort (including but not limited to negligence and strict liability) or otherwise, and Trex's liability with respect to Products shall in no event exceed the replacement of such products or refund of the purchase price, as described above.

Some states do not allow the exclusion or limitation of incidental or consequential damages, so the above limitation or exclusion may not apply to you. This warranty gives you specific legal rights, and you may also have other rights that vary from state to state.

This warranty shall only be applicable and enforceable in the United States of America and Canada.

Copyright © 2011 Trex Company, Inc.

25-YEAR LIMITED RESIDENTIAL WARRANTY

Trex Company, Inc. (hereinafter "Trex") warrants to the original residential purchaser ("Purchaser") that, for a period of twenty-five (25) years from the date of original purchase, under normal residential use and service conditions, Trex® products shall be free from material defects in workmanship and materials, and shall not split, splinter, rot or suffer structural damage from termites or fungal decay. If a defect occurs within the warranty period, Purchaser shall notify Trex in writing and, upon confirmation by an authorized Trex representative of the defect, Trex's sole responsibility shall be, at its option, to either replace the defective item or refund the portion of the purchase price paid by Purchaser for such defective item (not including the cost of its initial installation).

Notwithstanding the foregoing, (a) with respect to Trex DeckLighting™, the term of the warranty for the LED lights and housing shall be seven (7) years, the term of the warranty for the dimmer, timer and transformer shall be three (3) years, in each case provided that a Trex transformer is used, and any other parts or accessories shall not be warranted, (b) with respect to hardware for the Trex Surroundings® gate (gate frame, hinges and screws), the term of the warranty shall be five (5) years, and (c) with respect to Trex Decorative Balusters, the term of the warranty covering the paint coating shall be ten (10) years, and shall be prorated in the following manner: 100% replacement for the first 5 years; and 50% replacement for the next 5 years.

For purposes of this warranty, a "residential purchaser" shall refer to an individual residential homeowner.

This warranty shall not cover and Trex shall not be responsible for costs and expenses incurred with respect to the removal of defective Trex products or the installation of replacement materials, including but not limited to labor and freight.

This warranty may be transferred one (1) time, within the five (5) year period beginning from the date of original purchase by the Purchaser, to a subsequent buyer of the property upon which the Trex products were originally installed.

To make a claim under this limited warranty, Purchaser, or the transferee, shall send to Trex, within the warranty period referred to above, a description of the claimed defect and proof of purchase, to the following address:

Trex Company, Inc.
Customer Relations
160 Exeter Drive
Winchester, VA 22603-8605

Trex does not warrant against and is not responsible for, and no implied warranty shall be deemed to cover, any condition attributable to: (1) improper installation of Trex products and/or failure to abide by Trex's installation guidelines, including but not limited to improper gapping; (2) use of Trex products beyond normal residential use, or in an application not recommended by Trex's guidelines and local building codes; (3) movement, distortion, collapse or settling of the ground or the supporting structure on which Trex products are installed; (4) any act of God (such as flooding, hurricane, earthquake, lightning, etc.), environmental condition (such as air pollution, mold, mildew, etc.), staining from foreign substances (such as dirt, grease, oil, etc.), or normal weathering (defined as exposure to sunlight, weather and atmosphere which will cause any colored surface to gradually fade, chalk, or accumulate dirt or stains); (5) variations or changes in color of Trex products; (6) improper handling, storage, abuse or neglect of Trex products by Purchaser, the transferee or third parties; or (7) ordinary wear and tear.

No person or entity is authorized by Trex to make and Trex shall not be bound by any statement or representation as to the quality or performance of Trex products other than as contained in this warranty. This warranty may not be altered or amended except in a written instrument signed by Trex and Purchaser.

UNDER NO CIRCUMSTANCES WILL TREX BE LIABLE FOR SPECIAL, INCIDENTAL OR CONSEQUENTIAL DAMAGES, WHETHER SUCH DAMAGES ARE SOUGHT IN CONTRACT, IN TORT (INCLUDING BUT NOT LIMITED TO NEGLIGENCE AND STRICT LIABILITY) OR OTHERWISE, AND TREX'S LIABILITY WITH RESPECT TO DEFECTIVE PRODUCTS SHALL IN NO EVENT EXCEED THE REPLACEMENT OF SUCH PRODUCTS OR REFUND OF THE PURCHASE PRICE, AS DESCRIBED ABOVE.

Some states do not allow the exclusion or limitation of incidental or consequential damages, so the above limitation or exclusion may not apply to you. This warranty gives you specific legal rights, and you may also have other rights that vary from state to state.

This warranty shall only be applicable and enforceable in the United States of America and Canada.

Copyright © 2011 Trex Company, Inc.

10-YEAR LIMITED COMMERCIAL WARRANTY

Trex Company, Inc. (hereinafter "Trex") warrants to the original end-user commercial purchaser ("Purchaser") that, for a period of ten (10) years from the date of original commercial purchase, under normal commercial use and service conditions, Trex® products shall be free from material defects in workmanship and materials, and shall not split, splinter, rot or suffer structural damage from termites or fungal decay. If a defect occurs within the warranty period, Purchaser shall notify Trex in writing and, upon confirmation by an authorized Trex representative of the defect, Trex's sole responsibility shall be, at its option, to either replace the defective item or refund the portion of the purchase price paid by Purchaser for such defective item (not including the cost of its initial installation).

Notwithstanding the foregoing, (a) with respect to Trex DeckLighting™, the term of the warranty for the LED lights and housing shall be seven (7) years, the term of the warranty for the dimmer, timer and transformer shall be three (3) years, in each case provided that a Trex transformer is used, and any other parts or accessories shall not be warranted, (b) with respect to hardware for the Trex Surroundings® gate (gate frame, hinges and screws), the term of the warranty shall be five (5) years, and (c) with respect to Trex Decorative Balusters, the limited warranty herein covering the paint coating shall be prorated in the following manner: 100% replacement for the first 5 years; and 50% replacement for the next 5 years.

For purposes of this warranty, a "commercial purchaser" shall refer to any purchaser other than an individual residential homeowner.

This warranty shall not cover and Trex shall not be responsible for costs and expenses incurred with respect to the removal of defective Trex products or the installation of replacement materials, including but not limited to labor and freight.

This warranty may be transferred to subsequent buyers of the property upon which the Trex products were originally installed.

To make a claim under this limited warranty, Purchaser, or any transferee, shall send to Trex, within the warranty period referred to above, a description of the claimed defect and proof of purchase, to the following address:

Trex Company, Inc.
Customer Relations
160 Exeter Drive
Winchester, VA 22603-8605

Trex does not warrant against and is not responsible for, and no implied warranty shall be deemed to cover, any condition attributable to: (1) improper installation of Trex products and/or failure to abide by Trex's installation guidelines, including but not limited to improper gapping; (2) use of Trex products beyond normal commercial use, or in an application not recommended by Trex's guidelines and local building codes; (3) movement, distortion, collapse or settling of the ground or the supporting structure on which Trex products are installed; (4) any act of God (such as flooding, hurricane, earthquake, lightning, etc.), environmental condition (such as air pollution, mold, mildew, etc.), staining from foreign substances (such as dirt, grease, oil, etc.), or normal weathering (defined as exposure to sunlight, weather and atmosphere which will cause any colored surface to gradually fade, chalk, or accumulate dirt or stains); (5) variations or changes in color of Trex products; (6) improper handling, storage, abuse or neglect of Trex products by Purchaser, any transferee or third parties; or (7) ordinary wear and tear.

No person or entity is authorized by Trex to make and Trex shall not be bound by any statement or representation as to the quality or performance of Trex products other than as contained in this warranty. This warranty may not be altered or amended except in a written instrument signed by Trex and Purchaser.

UNDER NO CIRCUMSTANCES WILL TREX BE LIABLE FOR SPECIAL, INCIDENTAL OR CONSEQUENTIAL DAMAGES, WHETHER SUCH DAMAGES ARE SOUGHT IN CONTRACT, IN TORT (INCLUDING BUT NOT LIMITED TO NEGLIGENCE AND STRICT LIABILITY) OR OTHERWISE, AND TREX'S LIABILITY WITH RESPECT TO DEFECTIVE PRODUCTS SHALL IN NO EVENT EXCEED THE REPLACEMENT OF SUCH PRODUCTS OR REFUND OF THE PURCHASE PRICE, AS DESCRIBED ABOVE.

Some states do not allow the exclusion or limitation of incidental or consequential damages, so the above limitation or exclusion may not apply to you. This warranty gives you specific legal rights, and you may also have other rights that vary from state to state.

This warranty shall only be applicable and enforceable in the United States of America and Canada.

Copyright © 2011 Trex Company, Inc.

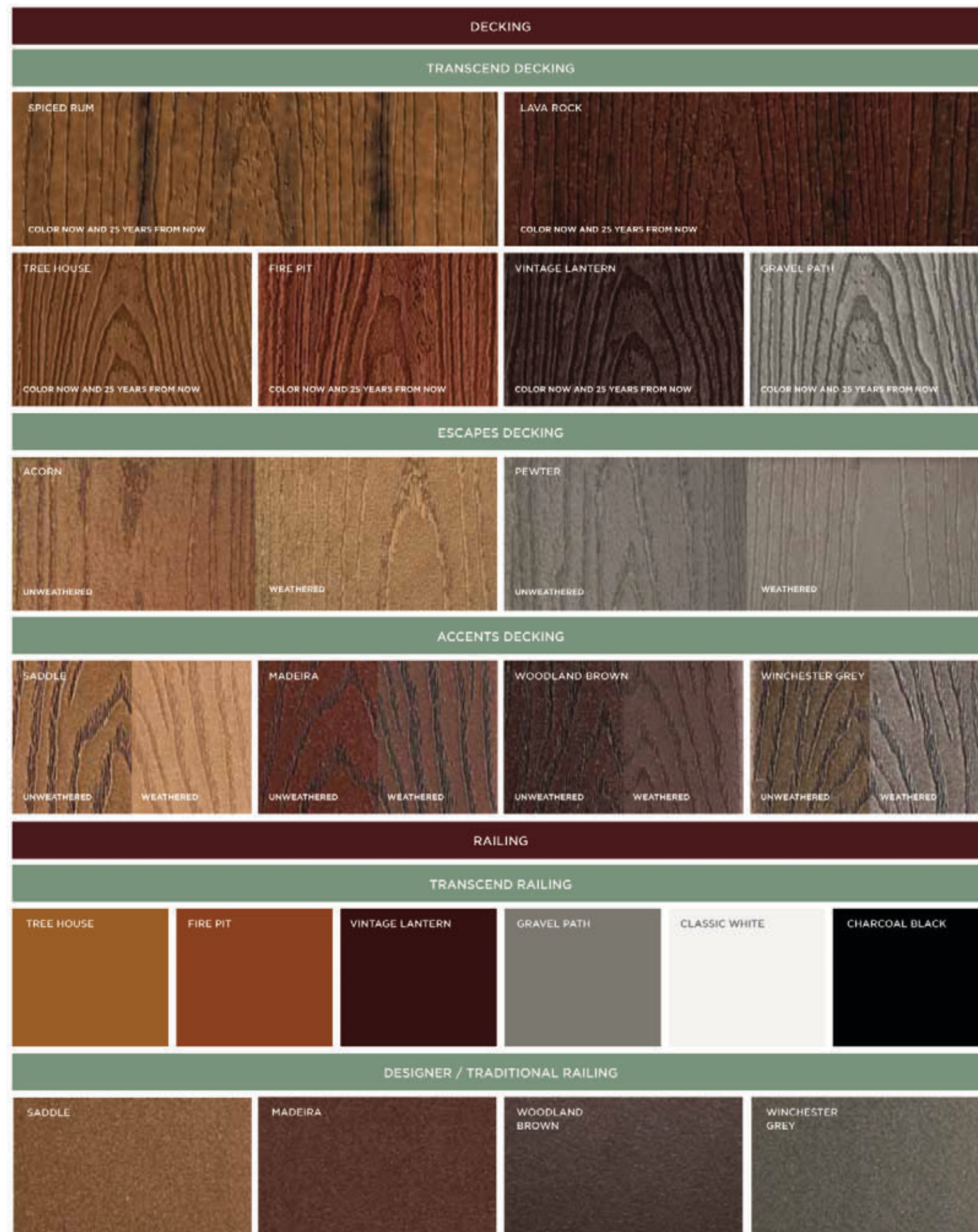

decking: Trex Transcend®
in Tree House & Vintage Lantern
railing: Trex Transcend
in Classic White with
contemporary balusters
in Charcoal Black
fascia: TrexTrim™



Trex®

HOW OUTDOOR LIVING SHOULD FEEL.

visit **trex.com** or call **1-800-BUY-TREX**

© 2011 Trex Company, Inc. All rights reserved. Trex®, Trex Transcend®, Trex Accents®, Trex Escapes®, Trex Designer Series Railing®, Trex Hideaway®, TrexTrim™, Trex Contours®, Trex CustomCurve™ and TrexExpress™ are either federally registered trademarks, trademarks or trade dress of Trex Company, Inc., Winchester, Virginia.

DKRLLT02-1110