

# SIEMENS

## SINUMERIK

### SINUMERIK 840D sl NCU

#### Manual

---

#### Preface

---

#### Safety Information

1

---

#### System overview

2

---

#### Application Planning

3

---

#### Description

4

---

#### Operating and display elements

5

---

#### Interfaces

6

---

#### Dimension drawings

7

---

#### Mounting

8

---

#### Connecting

9

---

#### Technical Data

10

---

#### Spare Parts/Accessories

11

---

#### Appendix



A

Applicable to controller  
SINUMERIK 840D sl/840DE sl

## Legal information

### Warning notice system

This manual contains notices you have to observe in order to ensure your personal safety, as well as to prevent damage to property. The notices referring to your personal safety are highlighted in the manual by a safety alert symbol, notices referring only to property damage have no safety alert symbol. These notices shown below are graded according to the degree of danger.

 <b>DANGER</b>
indicates that death or severe personal injury <b>will</b> result if proper precautions are not taken.
 <b>WARNING</b>
indicates that death or severe personal injury <b>may</b> result if proper precautions are not taken.
 <b>CAUTION</b>
with a safety alert symbol, indicates that minor personal injury can result if proper precautions are not taken.
<b>CAUTION</b>
without a safety alert symbol, indicates that property damage can result if proper precautions are not taken.
<b>NOTICE</b>
indicates that an unintended result or situation can occur if the corresponding information is not taken into account.

If more than one degree of danger is present, the warning notice representing the highest degree of danger will be used. A notice warning of injury to persons with a safety alert symbol may also include a warning relating to property damage.

### Qualified Personnel

The product/system described in this documentation may be operated only by **personnel qualified** for the specific task in accordance with the relevant documentation for the specific task, in particular its warning notices and safety instructions. Qualified personnel are those who, based on their training and experience, are capable of identifying risks and avoiding potential hazards when working with these products/systems.

### Proper use of Siemens products

Note the following:

 <b>WARNING</b>
Siemens products may only be used for the applications described in the catalog and in the relevant technical documentation. If products and components from other manufacturers are used, these must be recommended or approved by Siemens. Proper transport, storage, installation, assembly, commissioning, operation and maintenance are required to ensure that the products operate safely and without any problems. The permissible ambient conditions must be adhered to. The information in the relevant documentation must be observed.

### Trademarks

All names identified by ® are registered trademarks of the Siemens AG. The remaining trademarks in this publication may be trademarks whose use by third parties for their own purposes could violate the rights of the owner.

### Disclaimer of Liability

We have reviewed the contents of this publication to ensure consistency with the hardware and software described. Since variance cannot be precluded entirely, we cannot guarantee full consistency. However, the information in this publication is reviewed regularly and any necessary corrections are included in subsequent editions.

# Preface

## SINUMERIK® Documentation

The SINUMERIK documentation is organized in 3 parts:

- General documentation
- User documentation
- Manufacturer/Service Documentation

Information on the following topics is available at <http://www.siemens.com/motioncontrol/docu>:

- Ordering documentation  
Here you can find an up-to-date overview of publications.
- Downloading documentation  
Links to more information for downloading files from Service & Support.
- Researching documentation online  
Information on DOConCD and direct access to the publications in DOConWEB.
- Compiling individual documentation on the basis of Siemens contents with the My Documentation Manager (MDM), refer to <http://www.siemens.com/mdm>.  
  
My Documentation Manager provides you with a range of features for generating your own machine documentation
- Training and FAQs  
Information on the range of training courses and FAQs (frequently asked questions) are available via the page navigation

## Target group

This documentation is intended for manufacturers of machine tools, particularly:

- Project engineers, electricians and installers
- Maintenance and service personnel

## Benefits

The information in this manual facilitates installation and connection of the SINUMERIK 840D numerical control in the control cabinet.

## Standard scope

This documentation only describes the functionality of the standard version. Extensions or changes made by the machine manufacturer are documented by the machine manufacturer.

Other functions not described in this documentation might be executable in the control. However, no claim can be made regarding the availability of these functions when the equipment is first supplied or in the event of servicing.

For the sake of simplicity, this documentation does not contain all detailed information about all types of the product and cannot cover every conceivable case of installation, operation, or maintenance.

## Technical Support

If you have any technical questions, please contact our hotline:

	<b>Europe/Africa</b>
<b>Phone</b>	+49 180 5050 222
<b>Fax</b>	+49 180 5050 223
0.14 €/min. from German landlines, max. 0.42 €/min for calls from a mobile phone	
<b>Internet</b>	<a href="http://www.siemens.com/automation/support-request">http://www.siemens.com/automation/support-request</a>

	<b>America</b>
<b>Phone</b>	+1 423 262 2522
<b>Fax</b>	+1 423 262 2200
<b>E-mail</b>	<a href="mailto:techsupport.sea@siemens.com">techsupport.sea@siemens.com</a>

	<b>Asia/Pacific</b>
<b>Phone</b>	+86 1064 757575
<b>Fax</b>	+86 1064 747474
<b>E-mail</b>	<a href="mailto:support.asia.automation@siemens.com">mailto:support.asia.automation@siemens.com</a>

---

### Note

For technical support telephone numbers for different countries, go to:

<http://www.automation.siemens.com/partner>

---

## Questions about the documentation

If you have any questions (suggestions, corrections) regarding this documentation, please fax or e-mail us at:

Fax: +49 9131 98 2176

E-mail: <mailto:docu.motioncontrol@siemens.com>

A fax form is available in the appendix of this document.

## **SINUMERIK Internet address**

<http://www.siemens.com/sinumerik>

## **EC Declaration of Conformity**

The EC Declaration of Conformity for the EMC Directive can be found/obtained:

- On the Internet: <http://support.automation.siemens.com>  
under product/order number 15257461
- From the relevant regional office of the I DT MC division of Siemens AG

## **Convention**

Throughout this document, the term "Control Unit" is also used for product designations NCU 7x0, provided that the technical conditions described are applicable to all variants.



# Table of contents

	<b>Preface</b> .....	<b>3</b>
<b>1</b>	<b>Safety Information</b> .....	<b>11</b>
	1.1 Danger notices .....	11
	1.2 ESD notices .....	13
<b>2</b>	<b>System overview</b> .....	<b>15</b>
	2.1 Application.....	15
	2.2 System configuration .....	16
	2.3 Variants .....	17
<b>3</b>	<b>Application Planning</b> .....	<b>19</b>
	3.1 Secondary electrical conditions .....	19
	3.1.1 Protective Separation as per EN 61800-5-1 .....	19
	3.1.2 Grounding concept.....	20
	3.1.3 RI suppression measures .....	21
	3.2 Ambient Climatic and Mechanical Conditions.....	23
	3.2.1 Ambient conditions.....	23
	3.2.2 Transport and Storage Conditions .....	24
	3.2.3 Operating Conditions .....	26
<b>4</b>	<b>Description</b> .....	<b>29</b>
	4.1 Features .....	29
	4.2 Illustration .....	29
	4.3 Type plate .....	32
<b>5</b>	<b>Operating and display elements</b> .....	<b>33</b>
	5.1 Overview of operating and display elements .....	33
	5.2 CompactFlash Card .....	34
	5.2.1 Properties.....	34
	5.2.2 Inserting the CompactFlash card .....	35
	5.3 LED displays .....	36
	5.4 RESET button .....	37
	5.5 7-segment display .....	37
	5.6 Start-up and mode selector switch .....	38
<b>6</b>	<b>Interfaces</b> .....	<b>39</b>
	6.1 Interface overview .....	39
	6.2 Power supply X124 .....	40
	6.3 DRIVE-CLiQ interfaces X100 - X105.....	41
	6.4 Ethernet interfaces (X120, X130, X127) .....	42

6.5	PROFINET interfaces, ports 1, 2 .....	45
6.6	PROFIBUS–DP/MPI interfaces X126, X136 .....	47
6.7	Digital inputs/outputs X122 and X132 .....	48
6.7.1	Pin assignment.....	48
6.7.2	Technical data .....	50
<b>7</b>	<b>Dimension drawings .....</b>	<b>51</b>
7.1	Dimension drawing.....	51
<b>8</b>	<b>Mounting.....</b>	<b>53</b>
8.1	Safety information .....	53
8.2	Installation types .....	54
8.3	Mounting the control unit on the rear wall of the control cabinet .....	56
8.3.1	Mounting control unit using spacers .....	56
8.3.2	Mounting the Control Unit without spacers .....	56
8.3.3	Mounting the Control Unit for segregated heat removal .....	58
8.4	Lateral mounting of Control Unit on the SINAMICS drive line-up .....	60
<b>9</b>	<b>Connecting .....</b>	<b>61</b>
9.1	Overview .....	61
9.2	Safety information for wiring.....	63
9.3	Opening the front cover.....	63
9.4	Power supply.....	65
9.4.1	Requirements for the power supply .....	65
9.4.2	Connecting the power supply.....	66
9.5	DRIVE CLiQ components .....	67
9.5.1	DRIVE-CLiQ wiring .....	67
9.5.2	Connectable DRIVE-CLiQ components.....	68
9.6	Ethernet.....	69
9.7	PROFINET .....	69
9.7.1	Wiring PROFINET .....	69
9.7.2	PROFINET cables.....	70
9.7.3	Preparing the twisted pair cables.....	71
9.7.4	Example PROFINET CBA configuration.....	73
9.8	PROFIBUS / MPI .....	74
9.8.1	Application.....	74
9.8.2	PROFIBUS cables and connectors.....	74
9.8.3	Connection components in PROFIBUS .....	76
9.8.4	Rules for the laying of PROFIBUS cables .....	76
9.8.5	Connecting PROFIBUS DP.....	77
9.8.6	Disconnecting stations from the PROFIBUS .....	78
9.8.7	Operating the X136 interface as MPI.....	78
9.9	Digital inputs/outputs.....	80
9.9.1	Application.....	80
9.9.2	Connecting digital inputs/outputs .....	82
9.10	USB.....	83
9.11	Measuring sockets .....	84



---

<b>10</b>	<b>Technical Data</b> .....	<b>85</b>
<b>11</b>	<b>Spare Parts/Accessories</b> .....	<b>87</b>
11.1	Dual fan/ battery module.....	87
11.1.1	Application.....	87
11.1.2	Mounting .....	88
11.2	NX10/15 .....	90
11.2.1	Description .....	90
11.2.2	Operating and display elements .....	92
11.2.3	Interfaces .....	93
11.2.4	Dimension drawing .....	97
11.2.5	Mounting .....	98
11.2.6	Port.....	100
11.2.7	Technical Data .....	102
11.3	RS 232C (V.24) module COM01 .....	102
11.3.1	Description .....	102
11.3.2	Operator controls and displays .....	103
11.3.3	Interfaces .....	104
11.3.4	Installation/Mounting .....	105
11.4	TM15 Terminal Module .....	106
11.5	DRIVE-CLiQ Hub Module DMC20 .....	106
11.6	DME20 DRIVE-CLiQ Hub Module .....	107
11.7	Ordering data .....	107
<b>A</b>	<b>Appendix</b> .....	<b>109</b>
A.1	Abbreviations .....	109
A.2	Publication-specific information .....	110
A.2.1	Feedback on the documentation.....	110
A.2.2	Overview .....	112
	<b>Index</b> .....	<b>113</b>



## 1.1 Danger notices

The following notices are intended firstly for your personal safety and secondly to prevent damage occurring to the product described or any connected devices and machines. Non-observance of the warnings can result in severe personal injury or property damage.

 <b>DANGER</b>
<p>Only appropriately qualified personnel may commission/start-up SINUMERIK equipment.</p> <p>The personnel must take into account the information provided in the technical customer documentation for the product, and be familiar with and observe the specified danger and warning notices.</p> <p>When electrical equipment and motors are operated, the electrical circuits automatically conduct a dangerous voltage.</p> <p>When the system is operating, dangerous axis movements may occur throughout the entire work area.</p> <p>A potential fire hazard exists due to the energy being transferred in the equipment and the work materials used.</p> <p>All work on the electrical system must be performed after the system has been switched off and disconnected from the power supply.</p>

 <b>DANGER</b>
<p>Proper transportation, expert storage, installation and mounting, as well as careful operation and maintenance are essential for this SINUMERIK device to operate correctly and reliably.</p> <p>The details in the catalogs and proposals also apply to the design of special equipment versions.</p> <p>In addition to the danger and warning information provided in the technical customer documentation, the applicable national, local, and system-specific regulations and requirements must be taken into account.</p> <p>Only protective extra-low voltages (PELVs) that comply with EN 61800-5-1 can be connected to all connections and terminals between 0 and 48 V.</p> <p>Should it be necessary to test or take measurements on live equipment, then the specifications and procedural instructions defined in Accident Prevention Regulation VBG A2 must be adhered to, in particular § 8 "Permissible deviations when working on live components". Suitable electric tools should be used.</p>

 **WARNING**

Operating the equipment in the immediate vicinity (< 1.5 m) of mobile telephones with a transmitting power of > 1 W may lead to incorrect functioning of the devices.

Connecting cables and signal lines should be installed so that inductive and capacitive interference does not in any way impair the automation and safety functions.

 **DANGER**

Repairs to devices that have been supplied by our company may only be carried out by SIEMENS customer service or by repair centers authorized by SIEMENS.

When replacing parts or components, only use those parts that are included in the spare parts list.

EMERGENCY STOP devices EN 60204-1 (VDE 0113 Part 1) must remain active in all modes of the automation equipment. Resetting the EMERGENCY STOP device must not cause an uncontrolled or undefined restart.

Anywhere in the automation equipment where faults might cause physical injury or major material damage, in other words, where faults could be dangerous, additional external precautions must be taken, or facilities must be provided, that guarantee or enforce a safe operational state, even when there is a fault (e.g. using an independent limit value switch, mechanical locking mechanisms, EMERGENCY STOP devices)

## 1.2 ESD notices

### CAUTION

The modules contain electrostatically sensitive devices. Discharge yourself of electrostatic energy before touching the components. The easiest way to do this is to touch a conductive, grounded object immediately beforehand (for example, bare metal parts of control cabinet or the protective ground contact of a socket outlet).

### NOTICE

#### Handling ESD-modules:

- When handling electrostatically sensitive devices, make sure that operator, workplace and packing material are properly grounded.
- Generally, electronic modules must not be touched unless work has to be carried out on them. When handling PCBs make absolutely sure that you do not touch component pins or printed conductors.
- Touch components only if:
  - You are permanently grounded via an ESD armband
  - You are wearing ESD shoes or ESD shoe-grounding-strips, if ESD flooring is available
- Modules may only be placed on electrically conductive surfaces (table with ESD top, conductive ESD foam plastic, ESD packaging bags, ESD transport containers).
- Keep modules away from visual display units, monitors or TV sets (minimum distance from screen 10 cm).
- Do not bring ESD-sensitive modules into contact with chargeable and highly-insulating materials, such as plastic, insulating table tops or clothing made of synthetic materials.
- Measurements on modules are allowed only if:
  - The measuring instrument is properly earthed (e.g., protective conductor) or
  - Before measuring with a floating measuring instrument, the probe is briefly discharged (e.g., touch the bare metal parts of the control housing).



# System overview

## 2.1 Application

### Features

SINUMERIK 840D sl offers modularity, openness, flexibility, and uniform structures for operation, programming, and visualization. It provides a system platform with trend-setting functions for almost all technologies.

Integrated into the SINAMICS S120 drive system and complemented by the SIMATIC S7-300 automation system, the SINUMERIK 840D sl forms a complete digital system that is best suited for the mid to upper performance range.

The SINUMERIK 840D sl is characterized by:

- A high degree of flexibility
- Excellent dynamic response and precision
- Optimum integration into networks

Integrated and certified SINUMERIK Safety Integrated safety functions are available with SINUMERIK 840D sl. Consequently, highly effective protection for personnel and machines is achieved in a simple, economical, and practical manner.

Operating and programming software such as ShopMill or ShopTurn, as well as Motion Control Information System Products (MCIS-Products) can be used for the production sector.

### Fields of application

The SINUMERIK 840D sl can be used worldwide for turning, drilling, milling, grinding, laser machining, nibbling, punching, in tool and mold making, for high-speed cutting applications, for wood and glass processing, for handling operations, in transfer lines and rotary indexing machines, for mass production and JobShop production.

The SINUMERIK 840DE sl is available as an export version for use in countries requiring an export authorization.

## 2.2 System configuration

SINUMERIK 840D sl combines CNC, HMI, PLC, closed-loop control, and communication tasks within a single NCU (Numerical Control Unit).

### Components

For operation, programming, and visualization purposes, the corresponding operating software is already integrated into the CNC software for the NCU and therefore runs on the high-performance NCU multi-processor module. For increased operating performance, the SINUMERIK PCU 50.3 industrial PC can be used.

Up to four distributed OPs can be operated on one NCU/PCU. The operator panel can be installed as a Thin Client at a distance of up to 100 m.

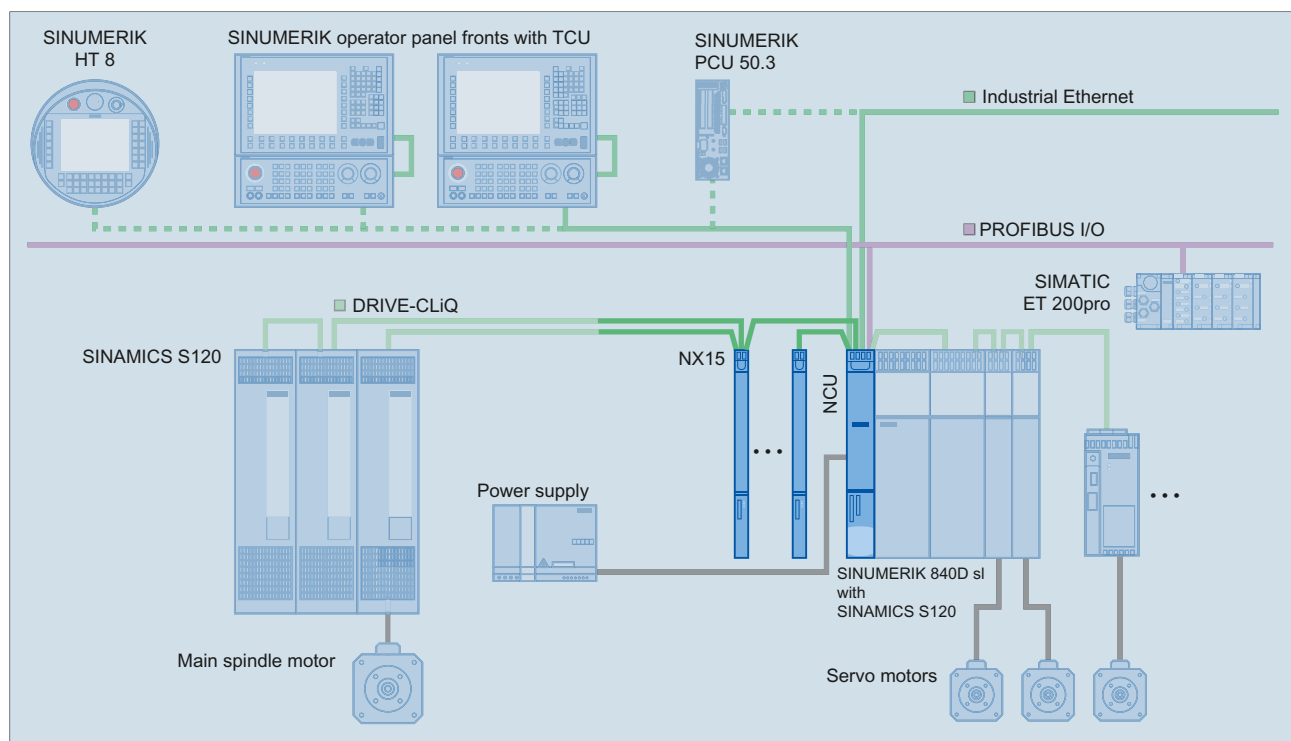

Figure 2-1 Typical topology of the SINUMERIK 840D sl complete system

The following components can be attached to the Control Unit:

- SINUMERIK operator panel front with TCU/PCU 50.3 and Machine Control Panel/Machine Push Button Panel
- SIMATIC CE panel
- SINUMERIK handheld units
- Distributed PLC I/O via PROFIBUS DP or PROFINET I/O (only applies to NCU 720.2 PN and NCU 730.2 PN)
- SINUMERIK PP 72/48 peripheral module
- SINUMERIK ADI 4 analog drive interface for four axes



- SINAMICS 120 drive system
- Feed and main spindle motors
  - 1FT/1FK/1FN/1FW6/1FE1/2SP1 synchronous motors
  - 1PH/1PM asynchronous motors

With the NCU 720.2 PN and NCU 730.2 PN, the SINUMERIK 840D sl is offering integrated PROFINET functionality for the first time.

Supported:

- PROFINET CBA functionality

The CBA functionality integrated in the NCU allows users to modularize machinery and systems: Rapid real-time communication (up to 10 ms) between the controllers means that systems lend themselves better to standardization and can be reused or expanded more easily. Response to customer demands is faster and more flexible and startup is simplified and speeded up by pretesting at component level.

- PROFINET IO

As part of PROFINET, PROFINET IO is a communication concept that is used to implement modular, distributed applications. PROFINET IO is based on Industrial Ethernet and allows distributed field and I/O equipment to be connected to the central processing unit.

256 PROFINET IO devices can be operated on the NCU as an IO controller.

## 2.3 Variants

The scalability of the hardware and software – both from a CNC perspective and in terms of operation – means the SINUMERIK 840D sl can be used in many sectors. The possibilities range from simple positioning tasks up to complex multi-axis systems.

### Application areas and performance

- As many as 6 axes can be implemented on an NCU 710. The NCU 710 can be expanded by up to 2 NX modules. One possible benefit would be improved servo drive control performance.
- On the NCU 720/730, the number of axes and/or the performance of the drive controller can be increased to 31 axes. This is achieved by using the NX10/15 module. The NCU 720/730 can be expanded by up to 5 NX10/15 modules in terms of drive controller performance and the number of axes.
- Use of an NCU 730 is recommended for maximum dynamics and accuracy in mold making or in the high speed cutting sector.
- Since it has the highest PLC capacity, the NCU 730.2 PN represents the most advanced configuration within the SINUMERIK 840D sl range.

The following table shows the essential features of the various Control Units:

Table 2-1 Variants

Property	NCU 710 .2	NCU 720.2/.2 PN	NCU 730.2/.2 PN
DRIVE CLiQ ports	4	6	6
Axes	Up to 6	Up to 31	Up to 31
NX10/15	Up to 2	Up to 3/Up to 5	Up to 3/Up to 5
TCU	Up to 2	Up to 4	Up to 4

# Application Planning

## 3.1 Secondary electrical conditions

### 3.1.1 Protective Separation as per EN 61800-5-1

#### Prerequisite

The complete system includes user interfaces (UIs) and interfaces for servicing, startup and maintenance.

#### User interfaces (UIs)

UIs are all the interfaces that are freely accessible to the machine operator without the need for tools or aids. These user interfaces provide protective separation up to 230 VAC according to EN 61800-5-1.

#### Interfaces for servicing, startup and maintenance

 <b>DANGER</b>
---

The interfaces for servicing/installation and start-up/maintenance purposes are provided <b>without</b> protective separation.
--

If necessary, these interfaces can be isolated safely using a supplementary adapter (insulation voltage 230 V AC). Although these adapters are not included in the Siemens scope of delivery, you can buy these parts from your local dealer, who will be happy to advise you.

 <b>DANGER</b>
---

Safe isolation can only be ensured if the system configuration specified below is strictly adhered to. When installing additional components (e.g. S7-300 FM, IP) with an end user interface, please make sure that the end user interface has protective separation for at least 230 VAC.
--

---

#### Note

The components of the drive control comply with EN 61800-5-1 and contain only circuits and customer terminals with class DVC A voltages and safety isolation from circuits with dangerous voltages (PELV circuits).

---

### 3.1.2 Grounding concept

#### Components

The SINUMERIK 840D sl system consists of a number of individual components which have been designed so that the system complies with the appropriate EMC and safety standards. The individual system components are:

- Numerical Control Unit (NCU)
- Machine Control Panel MCP, Machine Push Button Panel MPP
- Keyboard
- Operator panels (operator panel front + TCU/PCU)
- Distributor box and handheld unit
- S7-300 I/O with IM 153 interface module

#### Grounding measures

The individual modules are attached to a metal cabinet panel by means of screws. Make sure that near the screws a low-impedance contact of the Control Unit with the cabinet panel can be made. Insulating paints at the contact point must be removed. The electronics unit grounds of the modules are connected to each other via DRIVE-CLiQ.

It is permissible to have a cluster of operator components for ground connection/PA.

Example: The control panel on the swivel arm.

It is sufficient in this instance to connect the ground connections of, for example, the PCU, TCU, and operator panel front using a cable and to route a shared grounding conductor to the central ground connection in the control cabinet.

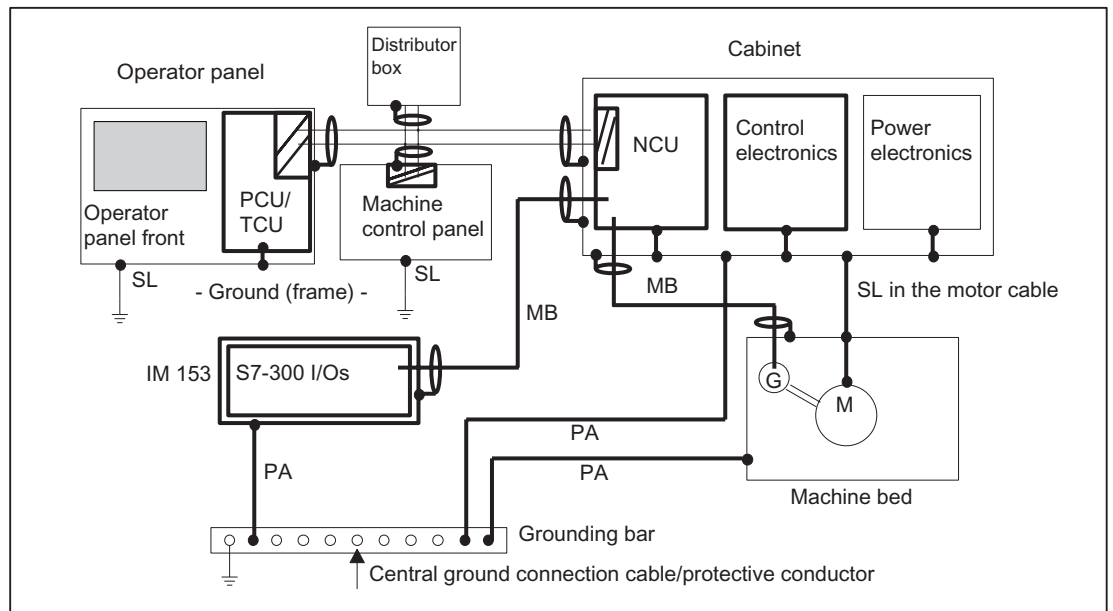

- MB      Shielded signal line with reference ground
- M        Motor
- G        Encoder
- PA      Equipotential bonding conductor
- SL      Protective conductor

Figure 3-1    Grounding concept

The following rules apply for external cable cross sections:

- Minimum PA cross section  $\geq 10 \text{ mm}^2$
- The cable cross section of the central protective conductor is calculated from the cable cross section of the line connection as follows:

Line connection S (mm <sup>2</sup> )	Protective conductor SL min. (mm <sup>2</sup> )
$S \leq 16$	S
$16 \leq S \leq 35$	16
$S \geq 35$	S/2

### Additional references

Configuration Manual, EMC Guidelines

### 3.1.3 RI suppression measures

In addition to the protective grounding of system components, special precautions must be taken to ensure safe, fault-free operation of the system. These measures include shielded signal lines, special equipotential bonding connections, and isolation and shielding measures.

### Shielded signal lines

- For the safe and smooth operation of the system, the specified cables must be used. Please refer to the chapter titled Connection.
- For digital signal transmission, the shielding must always be connected to the housings at both ends.

**Exception:**

If non-Siemens devices are connected (printers, programming devices, etc.), standard shielded cables grounded at one end can also be used. However, these devices must not be connected to the controller during normal operation. However, if the system cannot operate without them, then the cable shields must be connected at both ends. Furthermore, the non-Siemens device must be connected to the controller via an equipotential bonding cable.

### Cable definitions

- Signal cables (example)
  - Data cables (Ethernet, PROFIBUS, sensor cables, etc.)
  - Digital inputs/outputs
  - EMERGENCY OFF lines
- Load cables (example)
  - Low-voltage supply lines (230 VAC, 24 VDC, etc.)
  - Supply cables to contactors (primary and secondary circuit)

### Rules for routing cables

In order to maximize noise immunity for the complete system (controller, power section, machine) the following EMC measures must be observed:

- The distance between signal lines and load cables must be maximized.
- If necessary, signal and load cables may cross one another (if possible, at an angle of 90°), but must never be laid close or parallel to one another.
- Only use cables approved by SIEMENS for the signal lines from and to the Control Unit.
- Signal cables may not be routed close to strong external magnetic fields (e.g., motors and transformers).
- Pulse-loaded HC/HV lines must always be laid completely separately from all other lines.

- If signal lines cannot be routed a sufficient distance away from other cables, they must be installed in grounded cable ducts (metal).
- The clearance (interference injection area) between the following lines must be kept to a minimum:
  - Signal line and electrical circuit signal line (twisted)
  - Signal line and associated equipotential bonding conductor
  - Equipotential bonding conductor and protective conductor (routed together)

---

**Note**

For more specifications regarding interference suppression measures and connection of shielded cables, see

**References**

Configuration Manual, EMC Guidelines

---

## 3.2 Ambient Climatic and Mechanical Conditions

### 3.2.1 Ambient conditions

#### Observing the ambient conditions

The controller is tested for compliance with the ambient conditions specified below. Fault-free operation is only ensured if:

- These ambient conditions are maintained when storing, transporting and operating the equipment.
- Original components and spare parts are used. This applies in particular to the use of specified cables and connectors.
- The equipment is correctly installed and commissioned.



Commissioning is absolutely prohibited until it has been completely ensured that the machine, in which the components described here are to be installed, is in full compliance with the provisions of the EC Machinery Directive.

**Standard requirements**

The SINUMERIK 840D sl system components meet the following requirements in terms of standards:

Long-term storage	EN 60721-3-1
Transport	EN 60721-3-2
Stationary operation	EN 60721-3-3

**Assistance and support**

Compliance with environmental requirements must be ensured during installation of the complete system. Please contact your sales representative for assistance and support.

**3.2.2 Transport and Storage Conditions**

**Components in original packaging**

The following specifications apply to components in transport packaging:

Table 3-1 Climatic environmental conditions

	Transport	Storage
<b>Standard/Class</b>	EN 60721-3-2/2K4	EN 60721-3-1/1K4
<b>Temperature range</b>	-20 ... + 60 °C	-25 ... + 55 °C
<b>Temperature change</b>	-40 °C/+30 °C and +70 °C/+15 °C **)	< 0.5 K/min (± 30 K/h) *)
<b>Relative humidity</b>	5 ... 95 %	10 ... 100 %
<b>Permissible change in relative humidity</b>	Max. 0.1 % / min (± 6 % / h)	

\*) Averaged over 5 min

\*\*\*) Assuming a direct change in the specified air temperatures

Table 3-2 Test limit values for mechanical environmental conditions during transport/storage

<b>Vibration</b> to EN 60068-2-6	Frequency range	5 ... 9 Hz
	Constant deflection	7.5 mm
	Acceleration amplitude	9 ... 200 Hz: 2 <i>g</i>
<b>Shock resistance</b> to EN 60068-2-27	Acceleration	30 <i>g</i> ,
	Duration of nominal shock	6 ms
	Number of nominal shocks	18 shocks
	Shock form	Half-sine

*g* ≈ 9.81 m/s<sup>2</sup> (acceleration due to gravity)



### Shipping backup batteries

Backup batteries may only be shipped in the original packaging. No special authorization is required to ship backup batteries. The lithium content is approximately 300 mg.

---

#### Note

The backup battery is classified as a hazardous substance, Class 9, in accordance with the relevant air-freight transportation regulations.

---

### Storage of backup batteries

Always store backup batteries in a cool and dry place. The batteries have a maximum shelf life of 10 years.

### Rules for handling backup batteries

 <b>DANGER</b>
Incorrect handling of backup batteries can lead to a risk of ignition, explosion and combustion. The stipulations of DIN EN 60086-4, in particular regarding avoidance of mechanical or electrical tampering of any kind, must be complied with.

- Do not open a battery. Replace a faulty battery only with the same type.
- Obtain replacement batteries from Siemens alone (see Ordering data (Page 107)).
- Always try to return low batteries to the manufacturer or deliver these to a registered recycling company.

### 3.2.3 Operating Conditions

#### Climatic ambient conditions

If the specified values cannot be maintained, then a heat exchanger or air conditioner must be provided.

Table 3-3 Climatic environmental conditions to EN 60721-3-3, Class 3K5

<b>Temperature range</b>	0 ... 55°C	
<b>Temperature change</b>	< 0.5 K/min ( $\pm$ 30 K/h) averaged over 5 min	
<b>Humidity</b>	Relative: 5 to 90% at 25 °C	Absolute: $\leq$ 25 g/m <sup>3</sup>
<b>Permissible change in relative humidity</b>	Max. 0.1 % / min ( $\pm$ 6 % / h)	
<b>Moisture condensation and ice formation</b>	Not permissible	
<b>Dripping water, spray, splash water, water jets</b>	Not permissible	
<b>Supply air</b>	Without caustic gases, dusts and oils	
<b>Atmospheric pressure</b>	106 to 92 kPa or 0 to 1,000 m above sea level	
<b>Derating</b>	At altitudes over 1,000 to 4,000 m above sea level, the upper temperature limit must be reduced by 3.5 °C/500 m.	

Table 3-4 Test limit values for mechanical environmental conditions during operation

<b>Vibration</b> to EN 60068-2-6	Frequency band	10 ... 58 Hz
	Constant deflection	0.075 mm
	Acceleration amplitude	58 ... 200 Hz: 1 <i>g</i>
<b>Shock resistance</b> to EN 60068-2-27	Acceleration	5 <i>g</i>
	Duration of nominal shock	30 ms
	Number of nominal shocks	18 shocks
	Shock form	half-sine

$g \approx 9.81 \text{ m/s}^2$  (acceleration due to gravity)

#### Function-impairing gases

Degree of severity 3C2 according to EN60721-3-3

#### Function-impairing dust

When working in areas where gases, dust and oils may be hazardous to functionality, the controller must be operated in a control cabinet with a heat exchanger or with suitable supply air.

Table 3-5 Maximum permissible dust content in the air circulating in the control cabinet

Suspended component	0.2 mg/m <sup>3</sup>
Deposits	1.5 mg/m <sup>2</sup> /h

**Note**

Dust deposits must be removed at regular intervals.

**Radio interference**

Applicable standards: EN 61800-3

Table 3-6 Limit values for radio interference suppression in industrial environments

	Limit class according to EN 61800-3
Conducted radio interference	C3
Radio interference	C3

**Note**

The user must consider interference radiation for the complete system. Particular attention should be paid to cabling. Please contact your sales representative for assistance and support.

If compliance with limit value class C2 is required, please contact your local Siemens sales partner.

**NOTICE**

Please see the relevant SINAMICS documentation for EMC notes on how to deal with line filters and reactors.

**NOTICE**

The Control Unit is exclusively intended for installation in ESD-protected areas. The CE-associated ESD interference immunity limit values can only be achieved via installation in the control cabinet. Only make physical contact using appropriate ESD protective measures.



## Description

### 4.1 Features

A Control Unit has the following elements:

- Battery-backed real-time clock
- Slot for a CompactFlash Card
- DRIVE-CLiQ interfaces for connecting to the drive
- Interfaces for operation behind a hinged front cover:
  - Ethernet ports
  - 2 PROFINET interfaces for NCU 720.2 PN and NCU 730.2 PN
  - PROFIBUS interfaces
  - Digital inputs/outputs (6 of which can be parameterized as inputs for probe and BERO)
- Commissioning interfaces behind a blanking cover

### 4.2 Illustration

#### Control Units without PROFINET

The following figure shows an NCU 730.2 with its interfaces and control and display elements (fault displays and status indicators). Please ensure that the structure of the NCUs is virtually identical. There are only a few discrepancies, as follows:

- The NCU 710.2 has 4 rather than 6 DRIVE-CLiQ interfaces.
- Deviations with NCU 710.2 and NCU 720.2:
  - No cooling fins
  - Layout of control and display elements behind the blanking plate (see Chapter Position of operator control and display elements (Page 33))

Description

4.2 Illustration

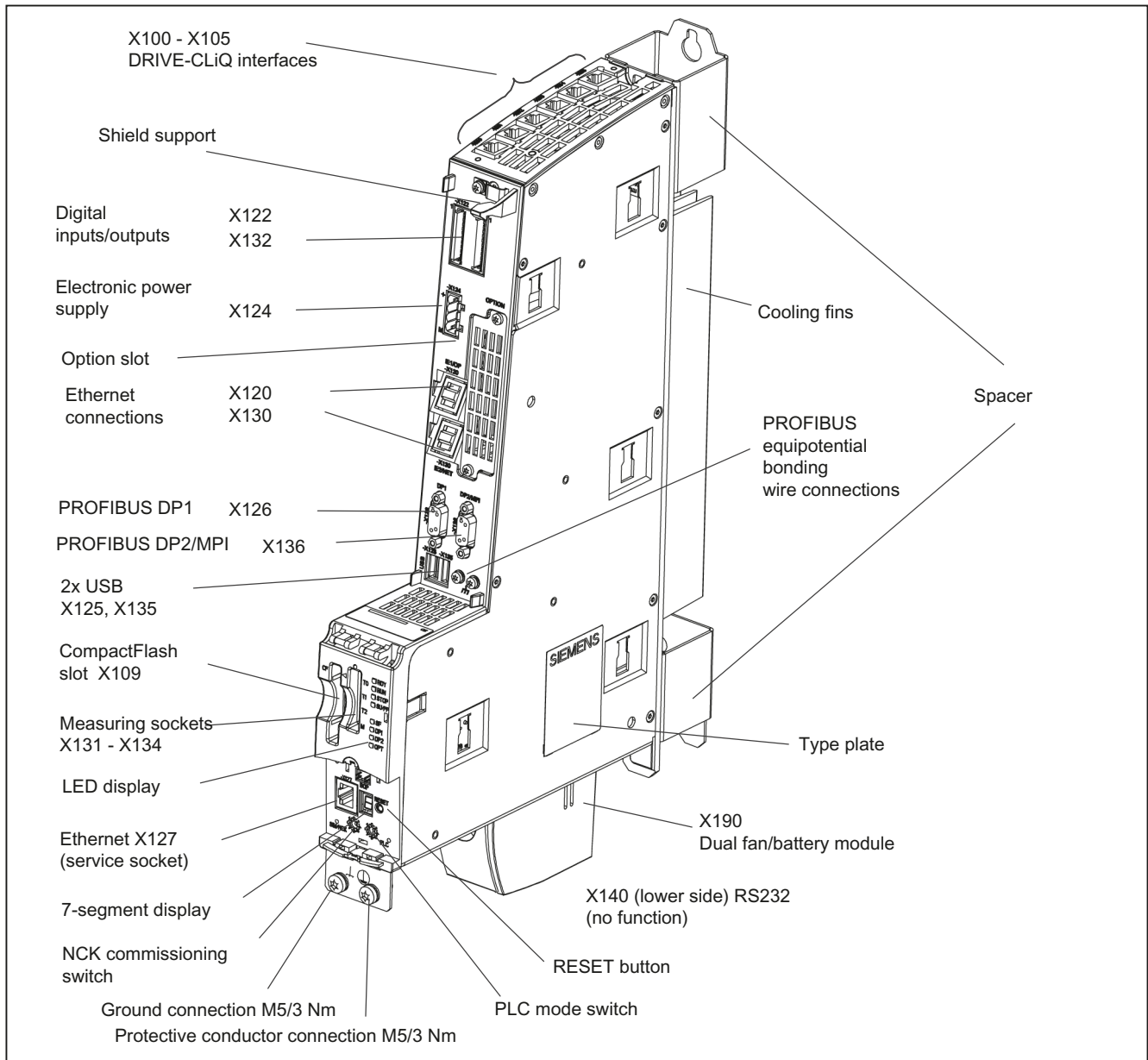

Figure 4-1 Representation of the NCU 730.2

## Control Units with PROFINET

The following figure shows an NCU 720.2 PN/730.2 PN with its interfaces and control and display elements (fault LEDs and status indicators).

### CAUTION

The PROFINET interfaces of the integrated PLC 319-3 PN/DP are permanently assigned to the option slot on the "PN NCUs". Forceful removal of the interface module will cause defects, which can only be repaired at the factory.

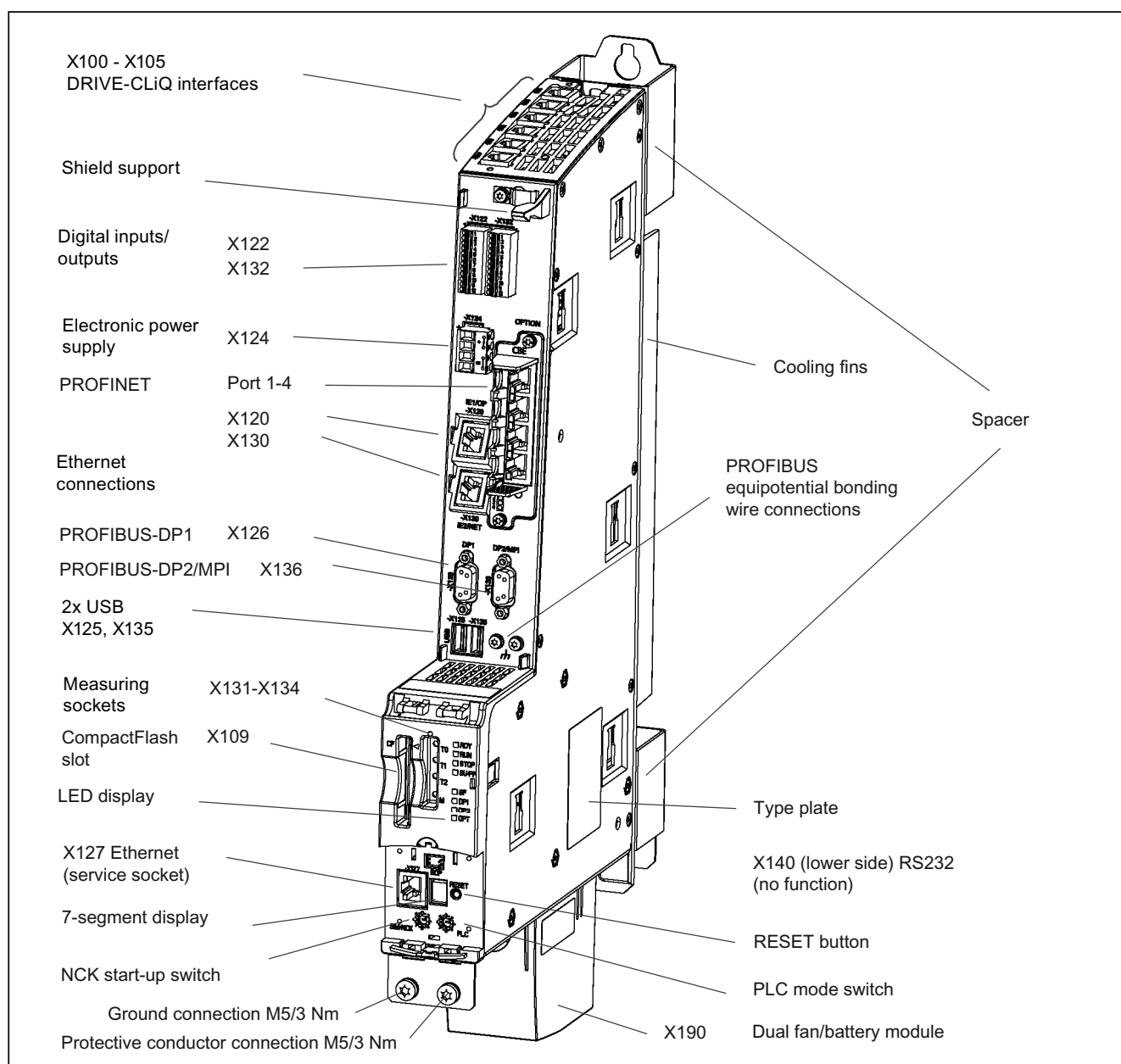

Figure 4-2 Representation of the NCU 720.2 PN/730.2 PN

## 4.3 Type plate

### Side-mounted type plate

The following figure shows you all the information included on the type plate located on the side of the unit.

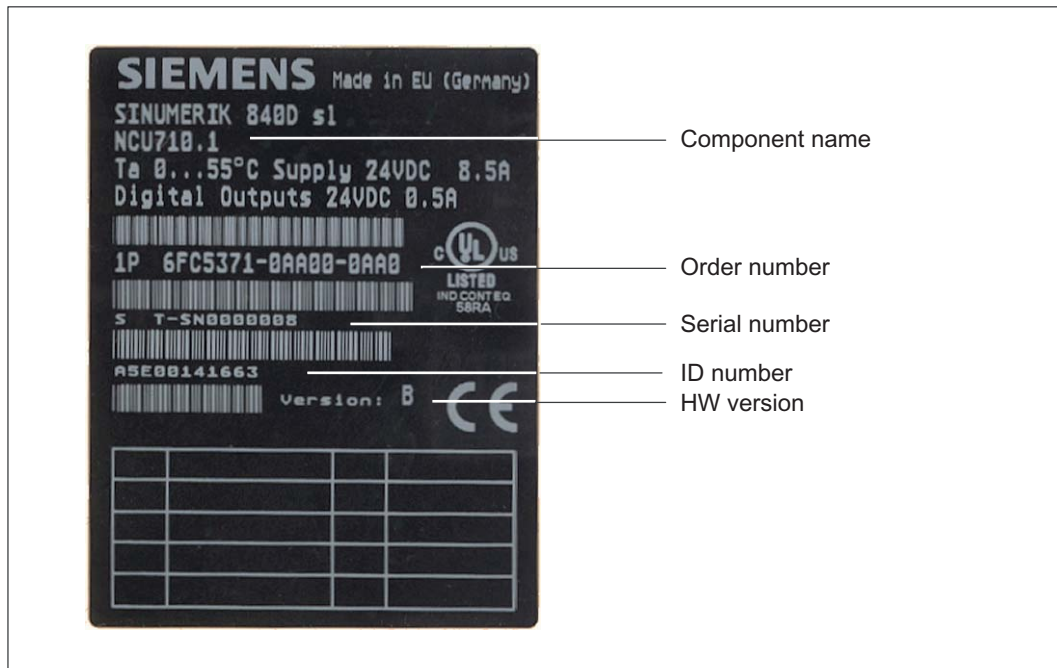

Figure 4-3 Type plate

You might need to access the information provided on the side-mounted type plate after the equipment has been mounted. Since the type plate is located on the right-hand side of the housing, which is the side typically used to connect to the SINAMICS S120 module, we recommend that you make a note of the serial number of the control unit prior to assembly.

#### Note

The information contained in each field of the type plate on the current control unit may differ from the information presented in this manual (for example, a later product version, approvals and marks that have not yet been issued, etc., may be shown).



## Operating and display elements

### 5.1 Overview of operating and display elements

NCU 720.2 PN/730.2/730.2 PN

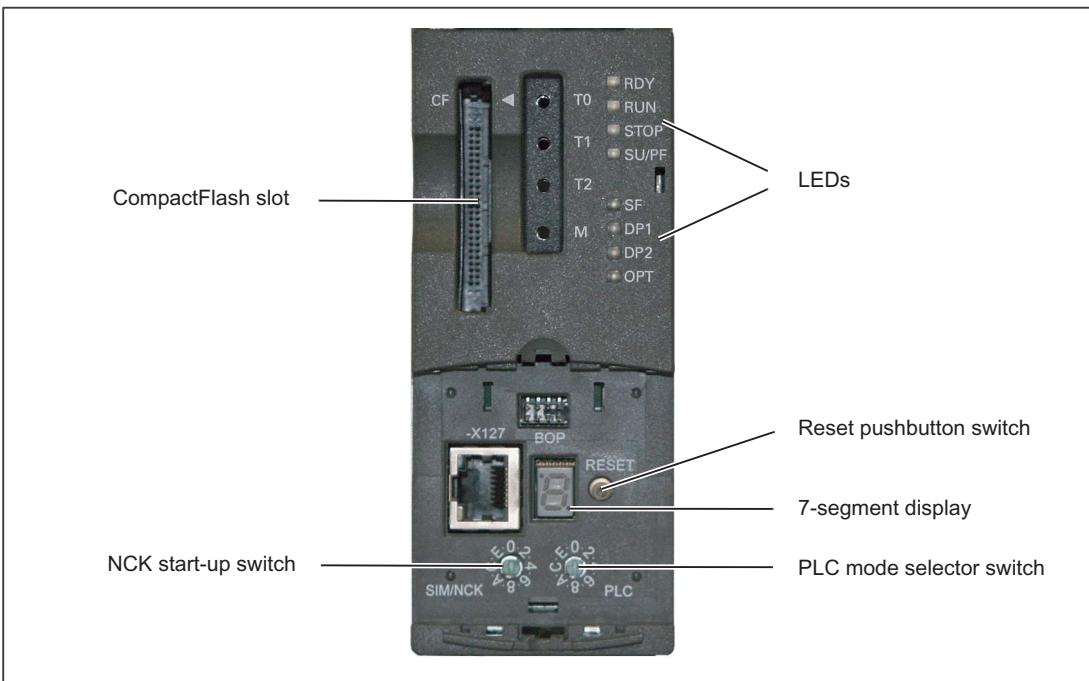

Figure 5-1 Position of operator control and display elements

## NCU 710.2/720.2

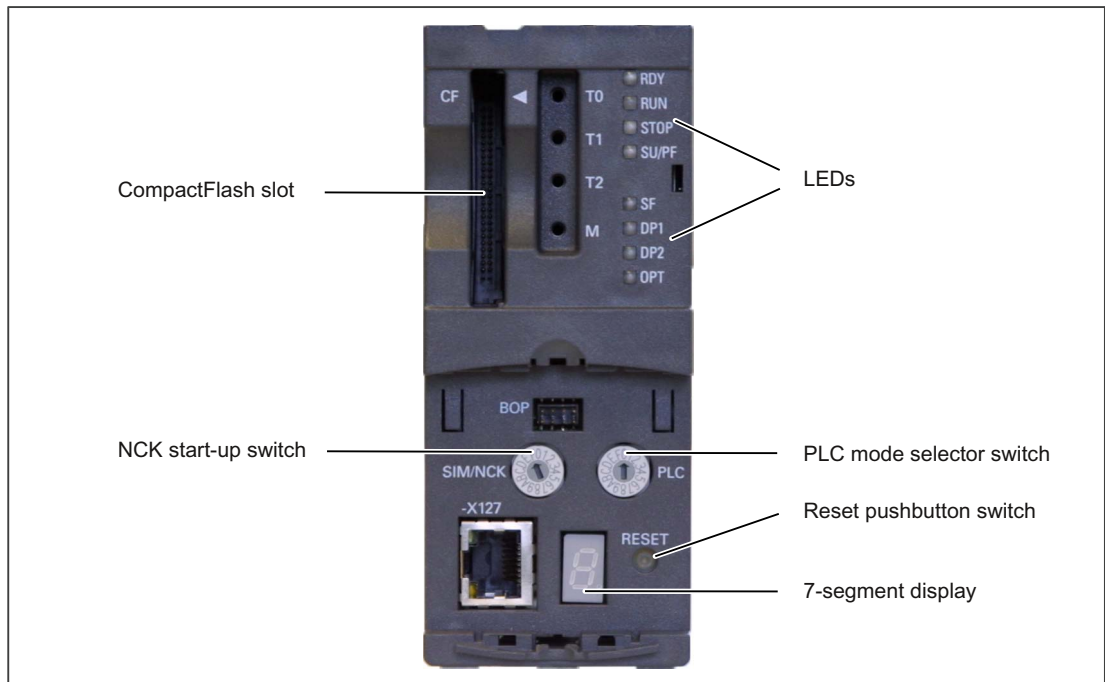

Figure 5-2 Position of operator control and display elements

## 5.2 CompactFlash Card

### 5.2.1 Properties

#### Application

The CompactFlash Card is delivered bootable. It is not supplied with the control unit and must be ordered as a separate component.

The CompactFlash Card is inserted in the CF plug-in slot (X109 interface).

#### **! CAUTION**

The CompactFlash Card may only be inserted or removed when the control unit is disconnected from the power supply.

#### Data

The CompactFlash Card is mandatory for operation of the control unit.

As well as the basic software for SINUMERIK and the firmware for SINAMICS, the CompactFlash Card also contains:

- User data (programs, configuration data, parameter settings)
- Version info (serial number, version, type designation)
- License key This means that the CompactFlash Card can be inserted into another control unit without requiring a license change.

## 5.2.2 Inserting the CompactFlash card

Proceed as follows

### NOTICE

ESD: you must discharge yourself at the cabinet or ground terminal before touching the CompactFlash Card.

Please proceed as follows:

1. Switch off the power supply.
2. Gently insert the new CompactFlash Card into the plug-in slot until it clicks into place. When properly installed, the card does not extend beyond the housing.
3. Switch the power supply on again.



Figure 5-3 Inserting the CompactFlash card

## 5.3 LED displays

Table 5-1 Meaning of LED states

Name	Function	Status	Meaning
RDY	Ready	Red	There is at least one fault (e.g. RESET, watchdog monitoring etc. ) or the Control Unit is booting up.
		Flashing red/orange (0.5 Hz)	Error accessing CompactFlash Card
		Orange	Accessing CompactFlash Card
		Flashing orange (0.5 Hz)	Updating the firmware of the connected DRIVE-CLiQ components
		Flashing orange (2 Hz)	Firmware update is complete for components. Wait for POWER ON for the components in question.
		Green	NC powered up and everything in cyclic mode
		Flashing green/orange or red/orange (1 Hz)	LED-supported recognition of connected DRIVE-CLiQ component is activated: (p0124[0] = 1).
RUN	PLC RUN	Green	PLC ready to operate
STOP	PLC STOP	Orange	PLC stopped
SU/PF	PLC FORCE	Red	FORCE activated
SF	PLC SF	Red	PLC group error
DP1	BUS1 F	Red	PROFIBUS-DP1 group error
DP2	BUS2 F	Red	PROFIBUS-DP2 group error
OPT *)	BUS3 F	Off	The PROFINET system runs correctly; data exchange to all configured IO devices runs.
		Red	<ul style="list-style-type: none"> <li>Bus fault (no physical connection)</li> <li>Incorrect transmission rate</li> </ul>
		Flashing red (2 Hz)	<ul style="list-style-type: none"> <li>Failure of a connected I/O device.</li> <li>Incorrect or no configuration.</li> </ul>

\*) The "OPT" LED is only significant for "PN NCUs".

**NOTICE**

If all the LEDs are flashing, the PLC must be reset via the mode selector (move switch to position "3" to reboot).

**Note**

While the Control Unit is powering up, all LEDs briefly light up orange. You can carry out a detailed diagnosis using a PG/PC and the operating software.

### **Additional references**

- You can find a detailed description of LED states during power-up in the "NCU Operating System (IM7)" section of the Basesoftware and Operating Software Commissioning Manual.
- For information on drive faults and alarms, see also: SINAMICS S120/S150 List Manual (LH1)

## **5.4 RESET button**

### **Arrangement**

The RESET button is located behind the blanking cover.

### **Performing a reset operation**

The reset operation resets the NCU and forces a new power-up. It is similar to a "Power On Reset" except that the 24 V power supply does not have to be switched off.

## **5.5 7-segment display**

### **Displaying messages**

The 7-segment display is located behind the blanking plate of the Control Unit. It serves as a status display during startup and performs the following tasks:

- Output of test and diagnostic messages.
- Output of status messages during booting

### **Critical messages**

- During normal operation, "6" appears here and the dot flashes.
- An "8" indicates that the fan is defective or that the Control Unit is operating without a fan.

### **Additional references**

CNC Commissioning Manual Part 1 (NCK, PLC, drive)

## 5.6 Start-up and mode selector switch

### Layout

The Control Unit has two coding switches in the lower section of the front panel.

- The left switch (labeled SIM/NCK) is the NCK startup switch.  
Setting during normal operation: "0"
- The right switch (labeled PLC) is the PLC mode selector switch.  
Setting during normal operation: "0"

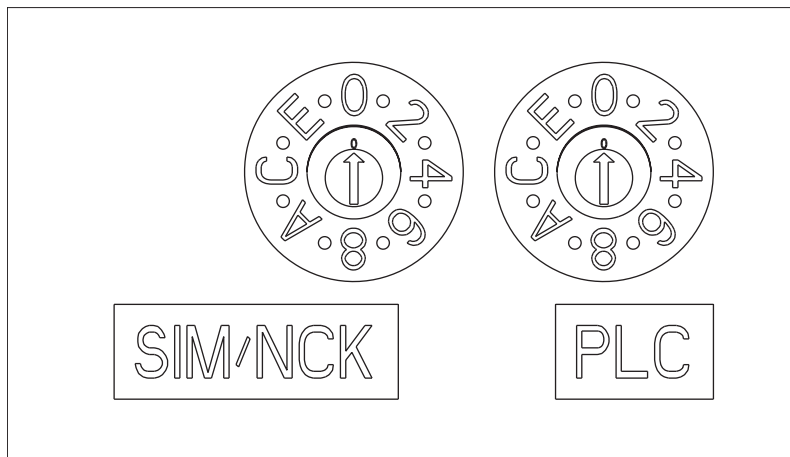

Figure 5-4 Startup and mode selector switch

### Additional references

CNC Commissioning Manual Part 1 (NCK, PLC, drive)

## Interfaces

### 6.1 Interface overview

#### Interface overview

Table 6-1 Overview of available external interfaces

Interface	Designation	Plug-connector type
DRIVE-CLiQ (0)	X100	Spec. RJ45 socket
DRIVE-CLiQ (1)	X101	Spec. RJ45 socket
DRIVE-CLiQ (2)	X102	Spec. RJ45 socket
DRIVE-CLiQ (3)	X103	Spec. RJ45 socket
DRIVE-CLiQ (4)	X104 (only NCU 720/730)	Spec. RJ45 socket
DRIVE-CLiQ (5)	X105 (only NCU 720/730)	Spec. RJ45 socket
Ethernet IE1/OP	X120	Standard RJ45 socket
Ethernet IE2/NET	X130	Standard RJ45 socket
Ethernet (service socket)	X127	Standard RJ45 socket
1st PROFINET interface	Port 1 (only "PN NCUs")	Standard RJ45 socket
2nd PROFINET interface	Port 2 (only "PN NCUs")	Standard RJ45 socket
Digital I/Os	X122, X132	Screw terminals, 2x12-pin
24 V power supply	X124	Screw terminals, 4-pin
USB interfaces	X125/X135	USB socket
PROFIBUS DP1	X126	9-pin SUB-D socket
PROFIBUS DP2/MPI	X136	9-pin SUB-D socket
RS232 interface	X140	9-pin SUB D plug connector
Test sockets (T0, T1, T2, and M)	X131 - X134	Sockets on the circuit board
CompactFlash Card	X109	50-pin socket
Dual fan/battery module	X190	6-pin

#### Note

For specifications regarding the cables to be connected and the use of interfaces, see the chapter titled "Connection".

## 6.2 Power supply X124

This interface is provided exclusively for connection of the external power supply.  
See Requirements for the power supply (Page 65).

### Pin assignment

Table 6-2 Power supply X124

Pin	Signal name	Signal type	Meaning
1	P24	VI	Power supply 24 V
2	P24	VI	
3	M	VO	
4	M	VO	Ground

Signal type: VI = voltage input; VO = voltage output

### Note

The two "+" or "M" terminals are jumpered in the connector. This ensures the 24 V voltage is looped through.

### Position of power supply interface

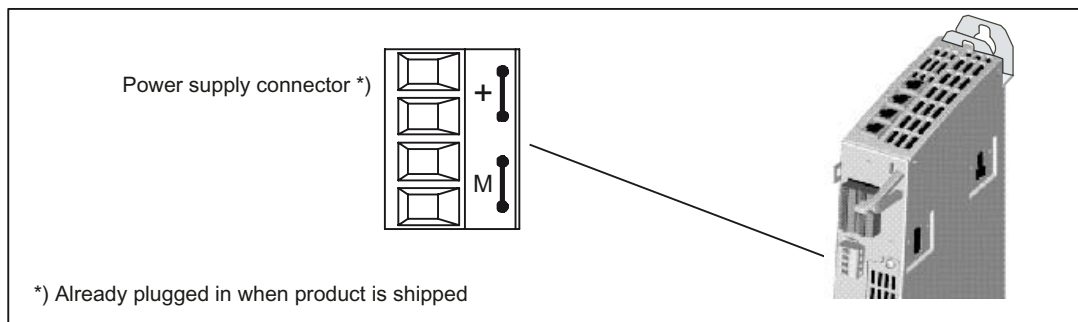

Figure 6-1 Power supply interface



## 6.3 DRIVE-CLiQ interfaces X100 - X105

### Properties

- Automatic detection of components
- 24 V/450 mA per DRIVE CLiQ interface is provided for the connection of encoders and measuring systems

### DRIVE-CLiQ pin assignment

Table 6-3 DRIVE-CLiQ interface (X100 - X103 or X100 – X105)

PIN	Signal name	Signal type	Meaning
1	TXP	O	Transmit data +
2	TXN	O	Transmit data -
3	RXP	I	Receive data +
4			Reserved, do not use
5			Reserved, do not use
6	RXN	I	Receive data -
7			Reserved, do not use
8			Reserved, do not use
A	+ (24 V)	VO	Voltage supply for DRIVE-CLiQ, 450 mA maximum
B	M (0 V)	VO	Ground to 24 V

Signal type: I = Input; O = Output; VO = Voltage Output

### Position of plug connectors

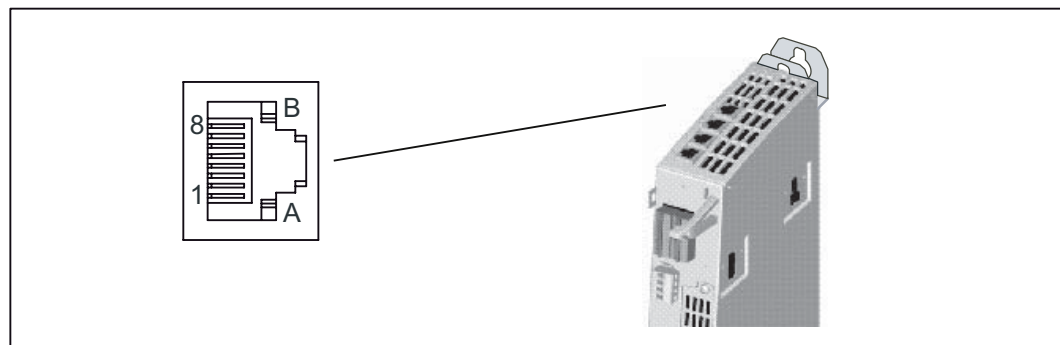

Figure 6-2 DRIVE-CLiQ interface

## 6.4 Ethernet interfaces (X120, X130, X127)

### Properties

The interfaces are full duplex 10/100 Mbit Ethernet ports. Both ports are connected as an Ethernet terminal.

### Pin assignment

Table 6-4 Ethernet interfaces X120, X130, X127

Pin	Signal name	Signal type	Meaning
1	TX+	Output	Transmit data +
2	TX-	Output	Transmit data -
3	RX+	Input	Receive data +
4	NC		
5	NC		
6	RX-	Input	Receive data -
7	NC		
8	NC		

### LED displays

For diagnostic purposes, the RJ45 sockets are each equipped with a green and an orange LED. This allows the following status information about the respective Ethernet port to be displayed:

Table 6-5 Ethernet port LED displays

LEDs	Status	Meaning
Green	To	10 or 100 Mbit link available
	Off	Missing or faulty link
Orange	To	Receive or transmit activity
	Off	No activity

### Position of connectors

The following figure shows the mounting position and designation of the Ethernet connectors on the module.

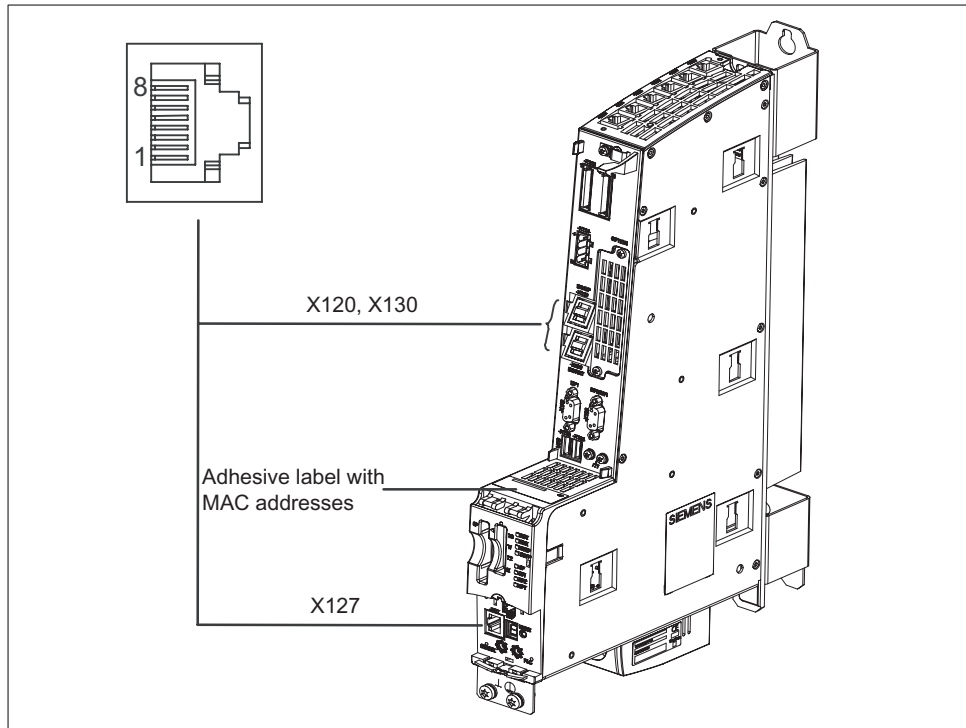

Figure 6-3 Position of the Ethernet interfaces

### MAC addresses

A type plate for the MAC addresses of the Ethernet interfaces is attached to the front panel of the Control Unit:



Figure 6-4 MAC addresses of Ethernet interfaces X120, X130, X127

You can see this type plate when you open the front cover of the Control Units **without** PROFINET.

## 6.5 PROFINET interfaces, ports 1, 2

### Properties

The interfaces are full-duplex 100 Mbit Ethernet ports with an integrated 2-port switch and a TCP/IP address for the 2 ports.

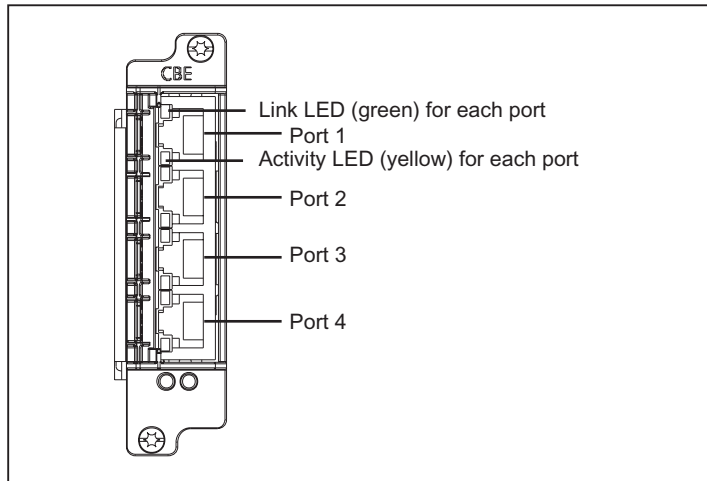

Figure 6-5 Representation of the PROFINET interfaces

#### NOTICE

##### NCU system software V2.6 with PLC software V2.7

Ports 1 and 2 are freely available for use, but ports 3 and 4 are deactivated. With PLC software < V2.7, the full range of options for PROFINET-based communication can only be guaranteed for port 1.

### Pin assignment

Table 6-6 PROFINET interfaces, ports 1, 2

Pin	Signal name	Signal type	Meaning
1	TX+	Output	Transmit data +
2	TX-	Output	Transmit data -
3	RX+	Input	Receive data +
4	NC		
5	NC		
6	RX-	Input	Receive data -
7	NC		
8	NC		

### Position of the ports

The 2 ports for the PROFINET connection are in the option slot of NCU 720.2 PN and NCU 730.2 PN.

### LED displays

For diagnostic purposes, the RJ45 sockets are each equipped with a green and an orange LED. This allows the following status information about the respective PROFINET port to be displayed:

Table 6-7 PROFINET ports LED displays

Name	Color	Status	Meaning
Link	Green	To	100 MBit link available
		Off	Missing or faulty link
Activity	Orange	To	Sending or receiving
		Off	No activity

Beneath the ports are 2 LEDs with no specific function.

### MAC addresses

A type plate for with the MAC addresses of the PROFINET/Ethernet interfaces is attached to the front panel of the NCU 720.2 PN and NCU 730.2 PN:



Figure 6-6 MAC addresses of the PROFINET/Ethernet interfaces

You can see this type plate when you open the front cover of the NCU 720.2 PN and NCU 730.2 PN.

### See also

PROFINET cables (Page 70)

## 6.6 PROFIBUS–DP/MPI interfaces X126, X136

### Properties

- Isolated RS 485 interface
- Max. data rate 12 Mbaud
- Supports master/slave operation
- PROFIBUS address is set via configuration
- OLPs (6GK1502-1AA00) are not permitted

#### Note

In addition to the DP (distributed I/Os) protocol, X136 can also transmit the MPI (multi-point interface) protocol (software-controlled).

### Pin assignment for X126, X136

Table 6-8 PROFIBUS DP interfaces (X126, X136)

Pin	Signal name	Signal type	Meaning
1	Nc	-	-
2	M	VO	Ground to P24_SERV
3	2RS_DP	B	RS485 differential signal
4	2RTS_DP	O	Request to Send
5	1M	VO	Ground to 1P5
6	1P5	VO	5 V power supply for bus terminal, external, short circuit-proof
7	P24_SERV	VO	24 V for teleservice, short circuit-proof, 150 mA maximum
8	2XRS_DP	B	RS485 differential signal
9	Nc	-	-
The 1P5 voltage is provided exclusively to supply the bus terminal.			
Signal type: VO = Voltage output (power supply) O = Output B = Bidirectional			

### Position of connectors

The following figure shows the mounting position and designation of the connectors on the Control Unit.

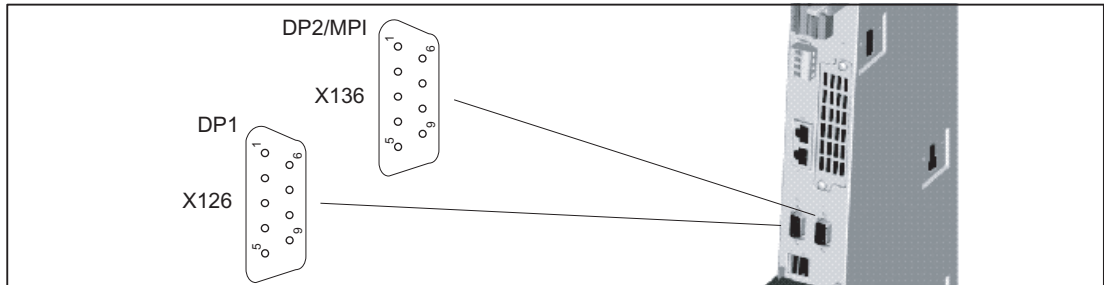

Figure 6-7 PROFIBUS DP/MPI interfaces

## 6.7 Digital inputs/outputs X122 and X132

### 6.7.1 Pin assignment

#### Position of connectors

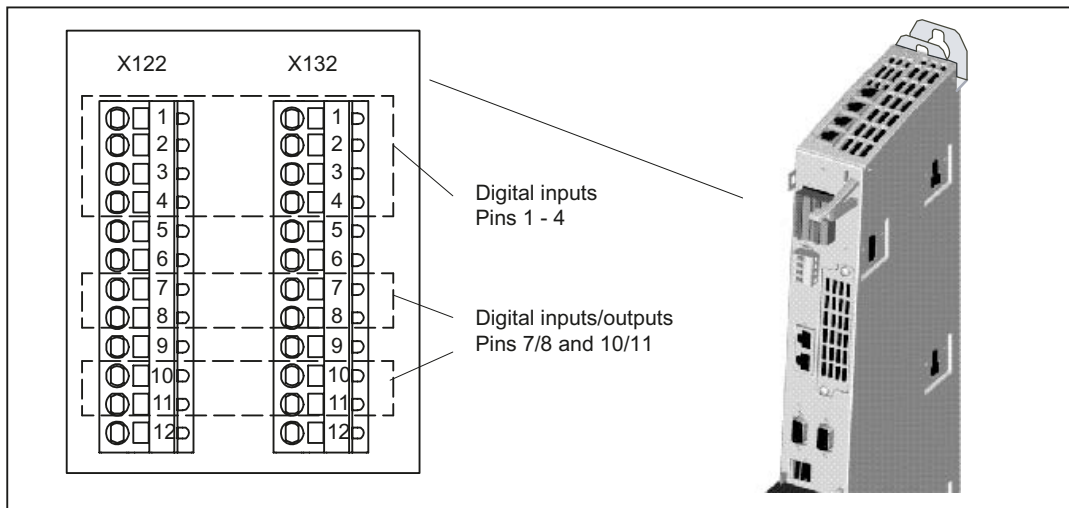

Figure 6-8 Digital inputs and digital inputs/outputs (interfaces X122 and X132)



## Pin assignment for X122 and X132

Table 6-9 X122 digital inputs/outputs

Pin	Signal name	Signal type	Meaning
1	DI0	I	Digital input 0
2	DI1	I	Digital input 1
3	DI2	I	Digital input 2
4	DI3	I	Digital input 3
5	M1	GND	Ground for DI0 - DI3 (functionally-separated relative to M)
6	M	GND	Ground
7	DI/DO8	B	Digital input/output 8
8	DI/DO9	B	Digital input/output 9 (rapid input)
9	M	GND	Ground
10	DI/DO10	B	Digital input/output 10 (rapid input)
11	DI/DO11	B	Digital input/output 11 (rapid input)
12	M	GND	Ground

Signal type: B = Bidirectional; I = Input; GND = Reference potential (ground)

Table 6-10 X132 digital inputs/outputs

Pin	Signal name	Signal type	Meaning
1	DI4	I	Digital input 4
2	DI5	I	Digital input 5
3	DI6	I	Digital input 6
4	DI7	I	Digital input 7
5	M2	GND	Ground for DI4 – DI7 (functionally-separated relative to M)
6	M	GND	Ground
7	DI/DO12	B	Digital input/output 12
8	DI/DO13	B	Digital input/output 13 (rapid input)
9	M	GND	Ground
10	DI/DO14	B	Digital input/output 14 (rapid input)
11	DI/DO15	B	Digital input/output 15 (rapid input)
12	M	GND	Ground

**Note**

The digital inputs/outputs are reserved by the system (terminal assignment).

6.7.2 Technical data

Digital inputs on X122/X132

Table 6-11 Technical data of digital inputs X122/X132

Parameter	Values
Voltage	-3 V to 30 V
Typical power consumption	10 mA at 24 V DC
Galvanic isolation	Reference potential is terminal M1 or M2
Signal level (including ripple)	High signal level: 15 V to 30 V
	Low signal level: -3 V to 5 V
Signal propagation delays	L → H: 50 μs
	H → L: 100 μs

Digital inputs/outputs on X122/X132

Table 6-12 Technical data of the digital inputs/outputs of X122/X132

Parameter	Values
As an input	
Voltage	-3 V to 30 V
Typical power consumption	10 mA at 24 VDC
Signal level (including ripple)	High signal level: 15 V to 30 V
	Low signal level: -3 V to 5 V
Pins 8, 10 and 11 are "rapid inputs"	
Signal propagation delays of inputs/"rapid inputs"	L → H: 50 μs/5 μs
	H → L: 100 μs/50 μs
As an output	
Voltage	24 V DC
Maximum load current per output	500 mA

**Note**

An open input is interpreted as "low".

Only "rapid inputs" can be used as inputs for BEROs and probes.

Terminals M1 or M2 must be connected for the digital inputs to work. This can be done as follows:

Connect the coupled-motion reference ground of the digital inputs, or provide a jumper to terminal M. (Notice! This removes the galvanic isolation for these digital inputs.)

## Dimension drawings

### 7.1 Dimension drawing

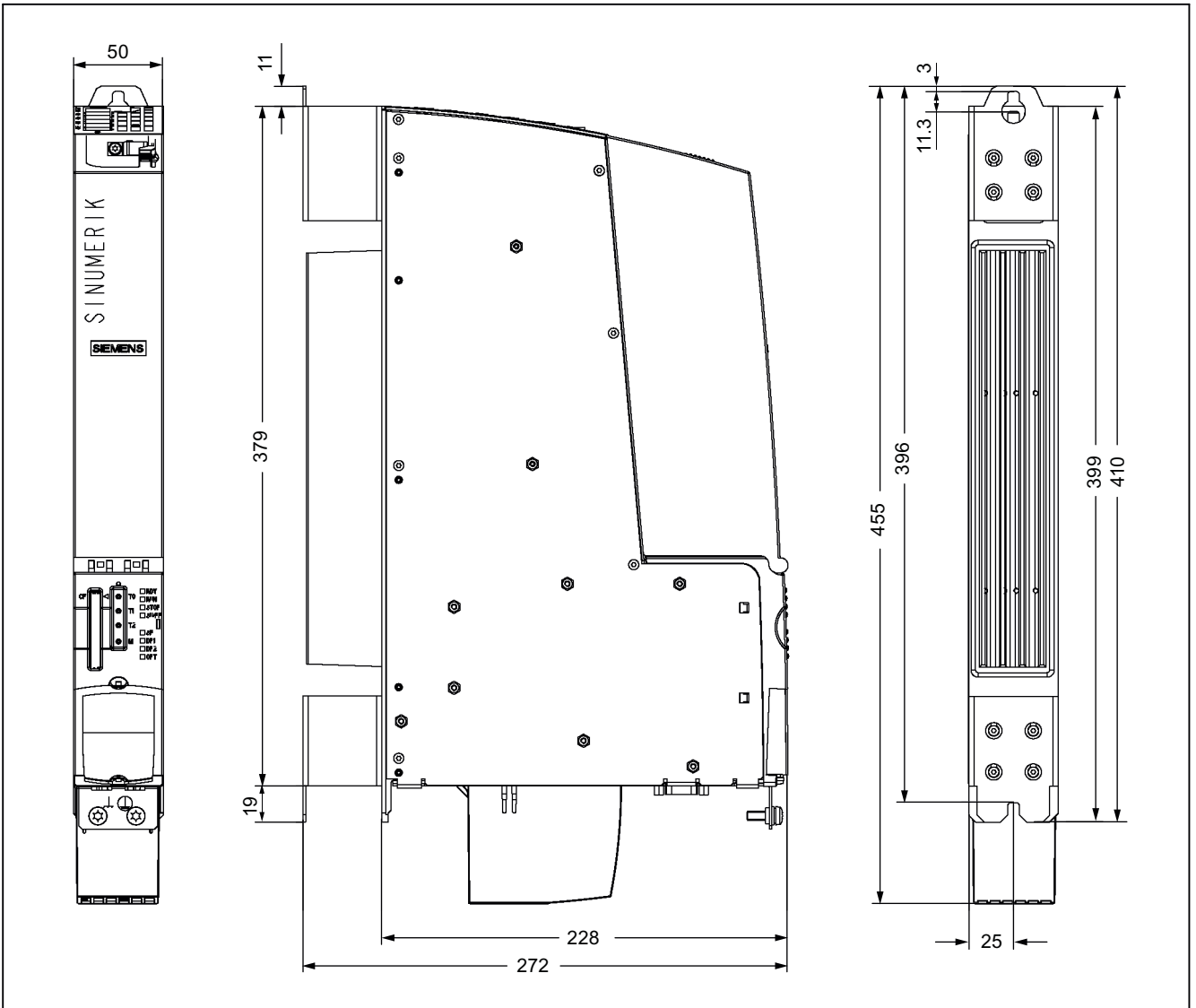

Figure 7-1 Dimension drawing of Control Unit (dimensions in mm)



# Mounting

# 8

## 8.1 Safety information

### Open equipment

These modules are open equipment. This means they may only be installed in housings, cabinets or in electrical service rooms that can be entered or accessed exclusively by means of a key or tool. Housings, cabinets, or electrical equipment rooms may only be accessed by trained or authorized personnel. An external fire protection casing is required.

 <b>DANGER</b>
The equipment must be deenergized when you mount the Control Unit.

### Control cabinet manufacture

Please refer to the SINAMICS documentation for more details.

<b>NOTICE</b>
The 80 mm ventilation spaces above and below the Control Unit must be observed.

If you have any further questions or are looking for particular solutions, you can contact the Systems Engineering Plant Chemnitz directly.

## 8.2 Installation types

### Prerequisite

The Control Unit is installed in a control cabinet along with the SINAMICS components.

The following prerequisites must be met to install a Control Unit:

- The control cabinet has been installed and wired.
- SINAMICS components should already have been installed and wired (for lateral mounting).
- Components and tools are available.

---

#### Note

The procedures described below for mounting the Control Unit refer to the delivery condition of the Control Unit: The upper clip is pulled in and the spacers are mounted (see figure below).

---

### Designs

The Control Unit is compatible with the SINAMICS S120 in booksize format. There are two possible mounting methods:

- Mounting on the rear wall of the control cabinet
- Lateral mounting on the SINAMICS S120 Line Module

In this type of mounting, the Control Unit is attached to the side wall of the Line Module in the control cabinet.

As the design of the Control Unit is based on that of the SINAMICS S120 family, please observe these notes and the corresponding reference documents.

### Mounting aids

The Control Unit is designed for mounting in a control cabinet (IP 20 degree of protection in accordance with general conditions).

---

#### Note

Exception: NCU 710.2 and NCU 720.2 have **no** cutouts for lateral mounting on the SINAMICS drive line-up.

---

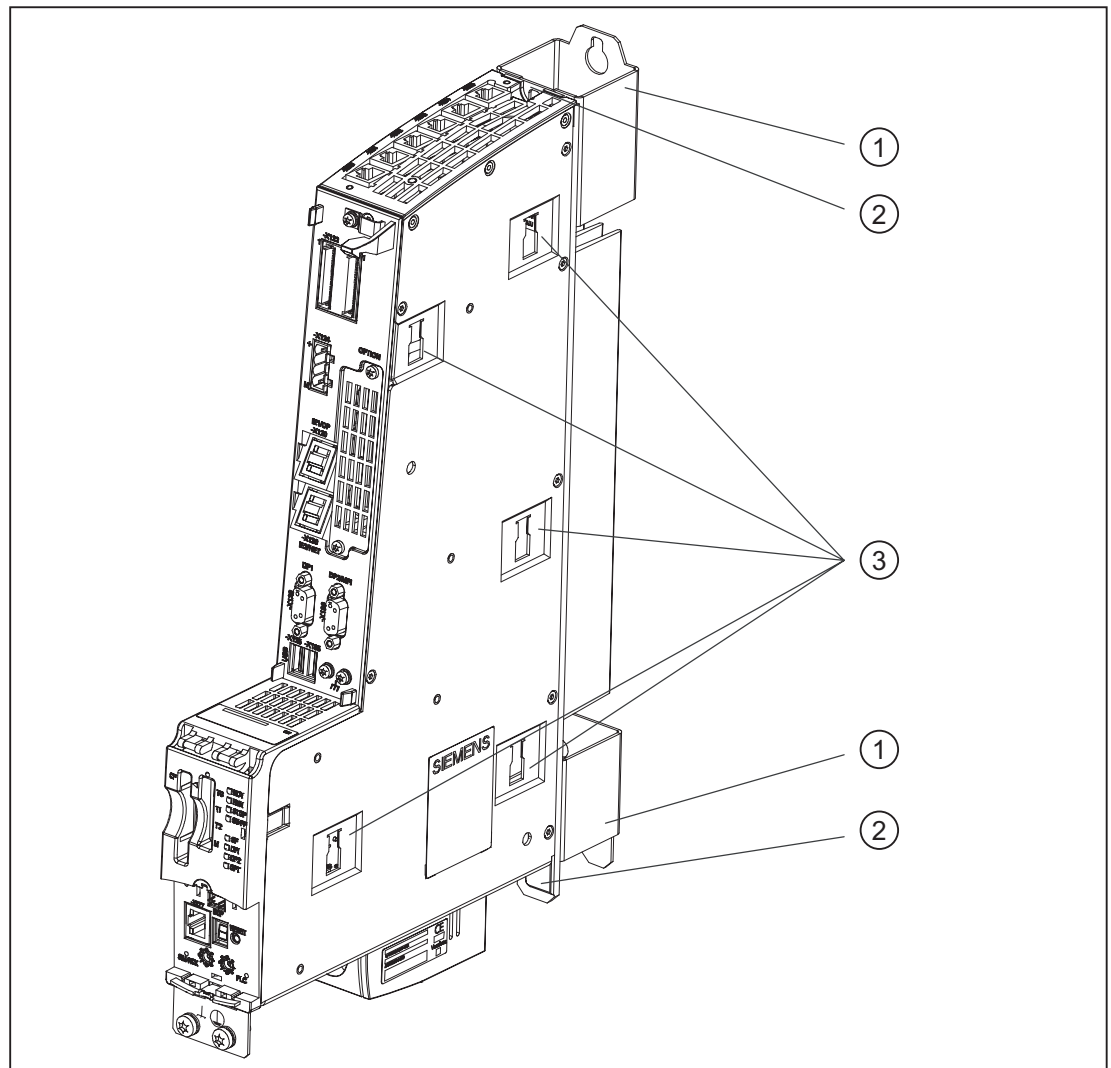

- (1) Spacers for mounting on the rear wall of the control cabinet
- (2) Lugs for mounting directly on the rear wall of the control cabinet (external heat dissipation)
- (3) Cutouts for lateral mounting on SINAMICS drive group

Figure 8-1 Mounting aids

## Mounting instructions

A seal can be provided for segregated heat removal on the Control Unit (apart from NCU 710.2 and NCU 720.2). This enables an air-tight connection to be made between the Control Unit and the rear wall of the control cabinet, i.e. the cooling fins are located outside the control cabinet.

## 8.3 Mounting the control unit on the rear wall of the control cabinet

### 8.3.1 Mounting control unit using spacers

#### Introduction

Spacers can be used to mount the control unit on a bare-metal highly-conductive rear wall of a control cabinet. This mounting method should be used if a number of Control Units are required or if you wish to isolate the Line Module spatially.

#### Procedure

Use two M5 (M6) screws in the spacers to mount the control unit to back rear wall of the control cabinet.

### 8.3.2 Mounting the Control Unit without spacers

#### Introduction

If you need to disconnect Control Units NCU 710.2 and NCU 720.2 from the Line Module, or simply wish to do so, you can mount them directly on the rear wall of the control cabinet without spacers.

#### Proceed as follows

The Control Unit has a metal clip at the top of the rear panel; when shipped, the clip is pushed in and secured with three M3 screws (0.8 Nm).

1. Remove the spacers.
2. Loosen the screws and push the clip up until the upper hole extends beyond the housing.



8.3 Mounting the control unit on the rear wall of the control cabinet

3. Tighten up the three screws on the clip again.
4. Mount the top and bottom of the Control Unit directly on the rear wall of the control cabinet with two M6 screws (6 Nm).

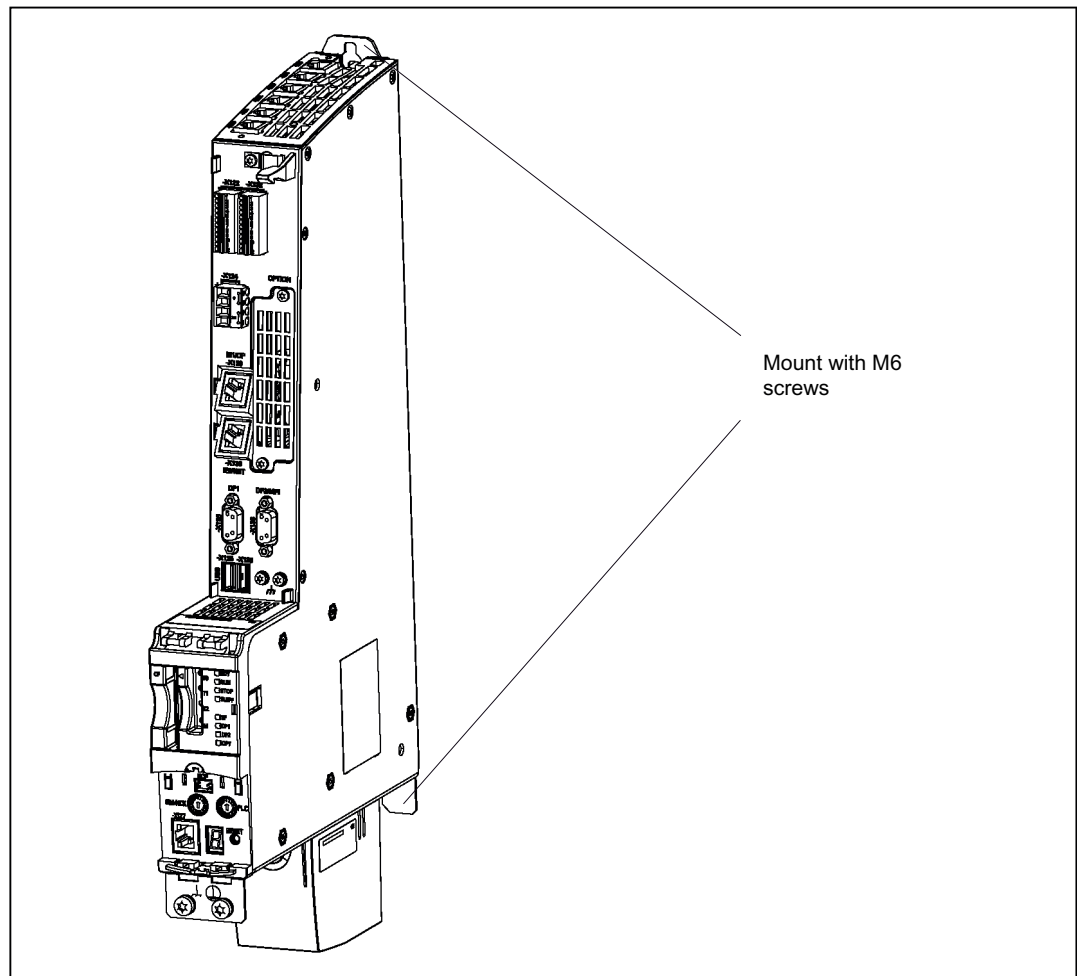

Figure 8-2 Mounting the Control Unit without spacers

### 8.3.3 Mounting the Control Unit for segregated heat removal

#### Introduction

If you wish to perform segregated heat removal on the NCUs with cooling fins, the NCUs can be mounted directly on the rear wall of the control cabinet without spacers.

#### Prerequisites

- The bushing for the cooling ribs (external heat sink) has been fitted in the rear wall of the control cabinet.
- Please ensure the area around the seal is both smooth and clean (② please see figure titled "Panel cutout").

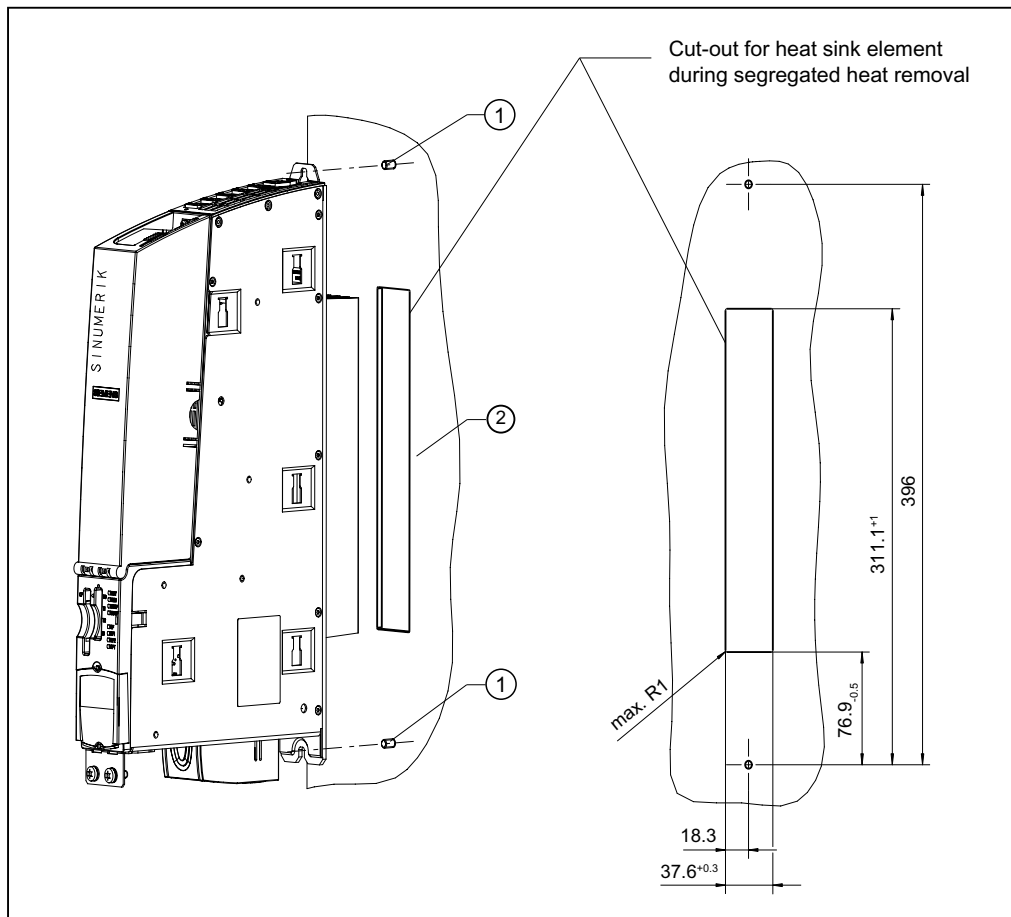
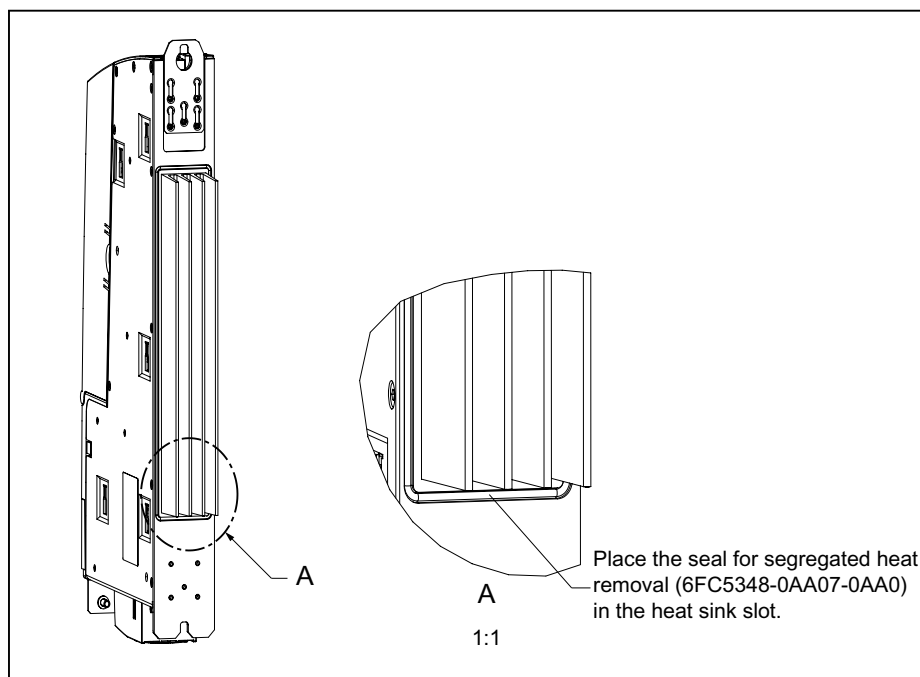

Figure 8-3 Panel cutout

## Procedure

1. Remove the spacers.
2. Fit the seal around the cooling ribs of the Control Unit.



3. Loosen the three M3 screws (0.8 Nm) on the upper clip and push the clip up until the upper hole protrudes beyond the housing.
4. Tighten up the three screws on the clip again.
5. Mount the top and bottom of the Control Unit with heat sink directly on the rear wall of the control cabinet using two M6 screws (6 Nm) (① see figure titled "Panel cutout").

## See also

Variants (Page 17)

## 8.4 Lateral mounting of Control Unit on the SINAMICS drive line-up

### Introduction

The Control Unit can also be mounted laterally on the SINAMICS drive line-up, on the side panel of a SINAMIC S120 Line Module. The required mounting elements are supplied with the Line Module.

---

### Note

Exception: NCU 710.2 and NCU 720.2 **cannot** be laterally mounted on the SINAMICS drive line-up.

---

### Proceed as follows

The Line Module has five mounting elements on the left-hand side. To mount the Control Unit, proceed as follows:

1. Remove the spacers from the Control Unit.
2. Position the Control Unit on the left-hand side of the Line Module. The mounting fixtures fit exactly in the five cutouts on the Control Unit.
3. Push the two units together.
4. Press down on the Control Unit until it engages and is securely connected to the Line Module.

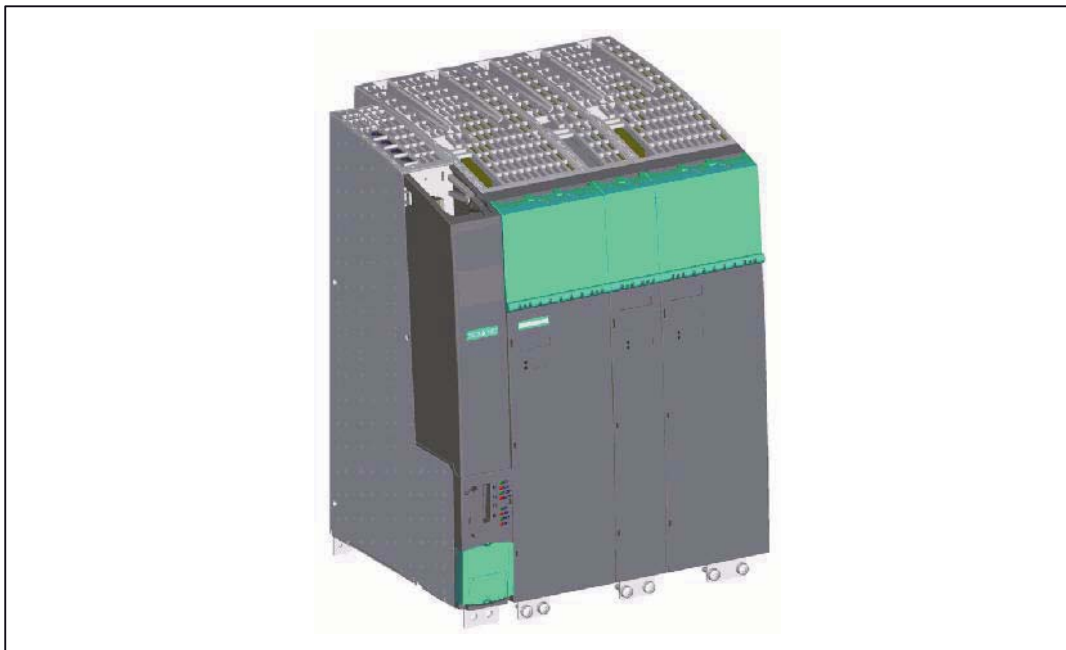

Figure 8-4 SINAMICS group with Control Unit

## 9.1 Overview

### Connection options

The Control Unit has a series of interfaces via which the power supply and the remaining system components are connected. The front cover on the Control Unit must be open to make the connections.

- The various SINAMICS components are connected with the Control Unit via DRIVE-CLiQ.
- Actuators and sensors can be connected to the digital inputs/outputs.
- The Control Units have the following communication options:
  - PROFIBUS DP, MPI, Ethernet
  - PROFINET with NCU 720.2 PN and NCU 730.2 PN

The following overview shows an example of the various interfaces and their connection options.

---

#### Note

All devices in the SINUMERIK 840D sl and SINAMICS S120 product families appear in Catalog NC 61. SIMATIC products that can be connected to the Control Unit appear in Catalog PM 10.

---

Connecting  
9.1 Overview

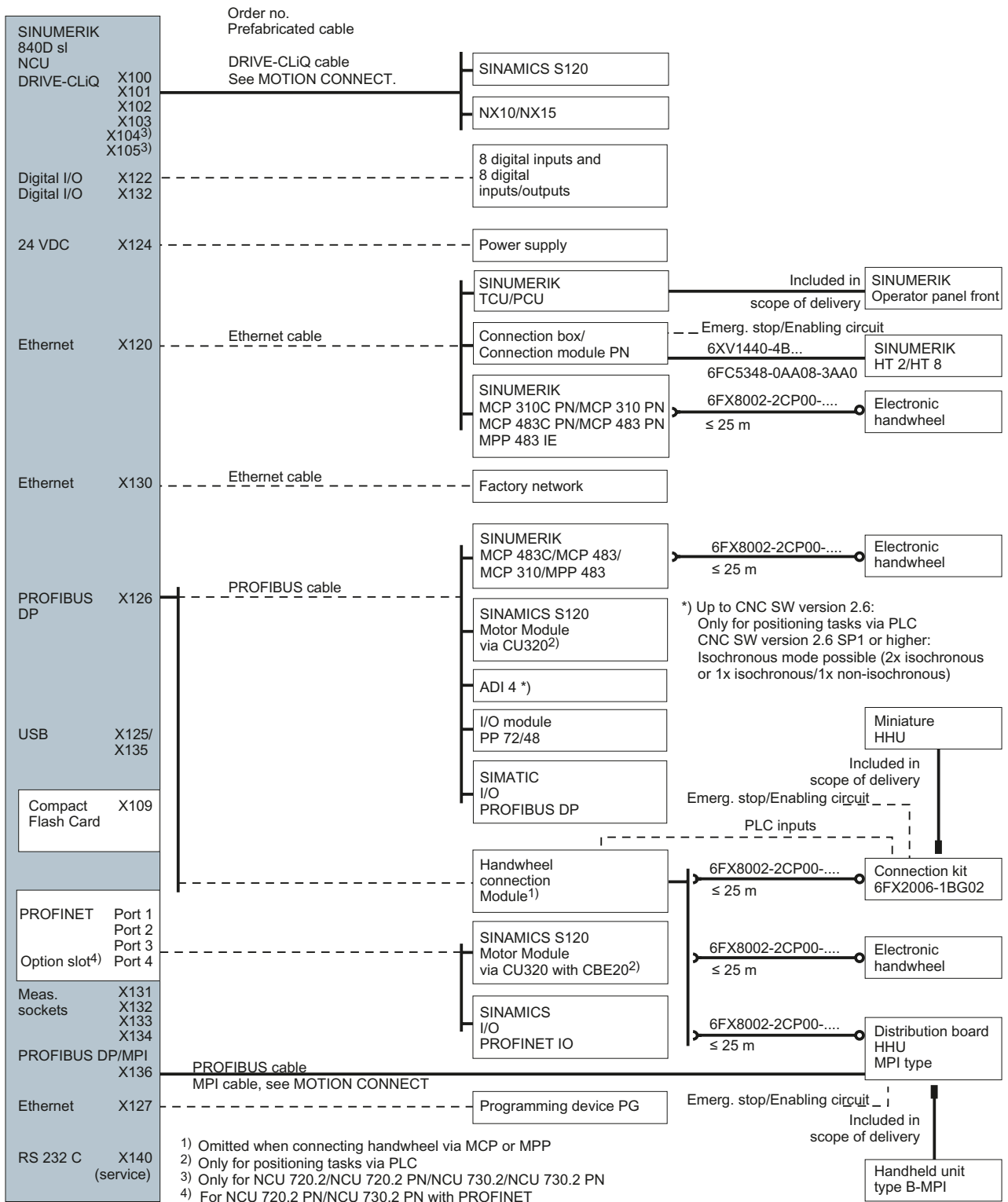



Figure 9-1 Connection options for a Control Unit

## 9.2 Safety information for wiring

Note the following:

### Safety information

 <b>DANGER</b>
The system power supply must be disconnected when you wire the control unit.
<b>NOTICE</b>
If your axis grouping contains a Smart Line Module without DRIVE-CliQ (5 kW or 10 kW), you must assign the Smart Line Module enable signal to digital output X122.1 on the control unit.

## 9.3 Opening the front cover

### Introduction

The interfaces are concealed behind a front cover. You must remove this cover before you can wire the interfaces.

A hinge connects the front cover to the front of the housing. Once opened, the cover can be completely removed. When the front cover is closed (flipped up), it automatically locks into place by means of a hook on the connector panel.

**Procedure**

1. Disengage the release hook on the inside of the front cover (the front cover is open and in the up position).
2. Remove the front cover with a forward motion.

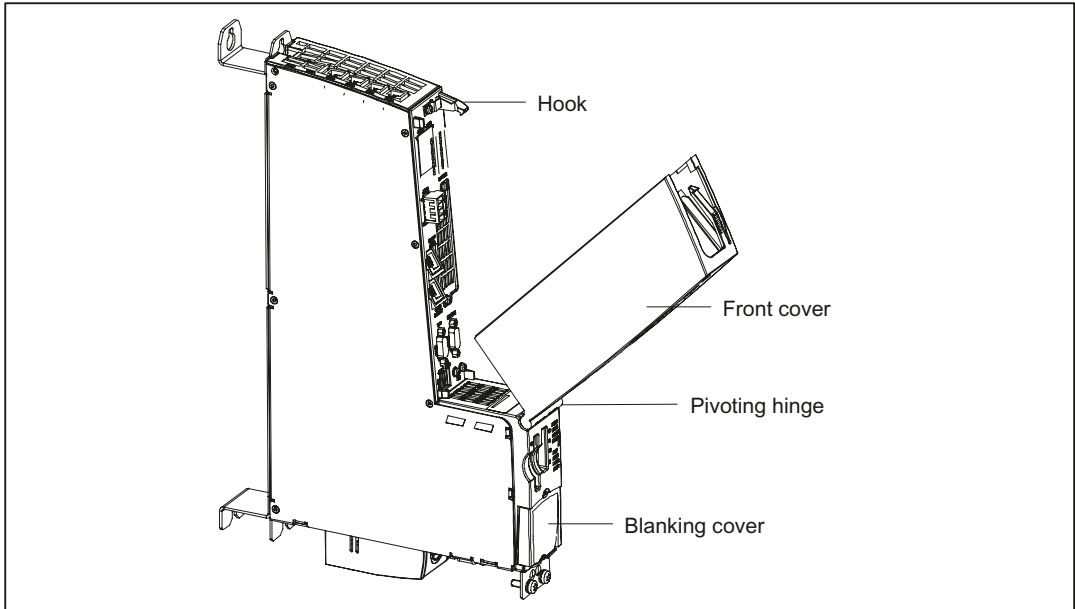

Figure 9-2 Removing the front cover

---

**Note**

All cables must be routed vertically upwards to the fullest extent possible so that the front cover can be closed. The front cover is open and in the up position.

---



## 9.4 Power supply

### 9.4.1 Requirements for the power supply

#### External 24 V power supply

Power is supplied to the Control Unit by an external 24 V power supply (e.g., SITOP). The following power consumption values for the Control Units provide a configuration basis for calculating the 24 V DC power supply.

Table 9-1 Input voltage specification

Parameters	Values
Typ. power consumption <sup>1)</sup>	2.0 A
Max. power consumption <sup>2)</sup>	8.5 A
<sup>1)</sup> NCU only (processor, memory, etc.)	
<sup>2)</sup> NCU with full load at all outputs (digital outputs, USB, DRIVE-CliQ, PROFIBUS DP etc.)	

#### Requirements of DC power supplies

 <b>DANGER</b>
<p>The DC power supply is always referenced to ground and may not be generated by an autotransformer.</p> <p>Final user interfaces are powered via a DC power supply with protective separation per EN 1800-5-1.</p> <p>In the case of supply lines &gt; 10 m, protectors must be installed at the device input in order to protect against lightning (surge).</p> <p>The DC power supply must be connected to the ground/shield of the Control Unit for EMC and/or functional reasons. For EMC reasons, this connection should only be made at one point. As a rule, the connection is provided as standard in the S7-300 I/Os. In exceptional circumstances when this is not the case, the ground connection should be made on the grounding rail of the control cabinet; please also refer to /EMC/EMC Installation Guide.</p>

Table 9-2 Requirements of the DC supply

<b>Rated voltage</b>	According to EN 61131-2	24 VDC
	Voltage range (average value)	20.4 to 28.8 V DC
	Voltage ripple peak-to-peak	5 % (unfiltered 6-pulse rectification)
	Ramp-up time at power-on	Any
<b>Non-periodic overvoltages</b>	Duration of overvoltage	≤ 35 V
	Restoration time	≤ 500 ms
	Events per hour	≥ 50 s
<b>Transient voltage interruptions</b>	Outage time	≤ 10
	Restoration time	≤ 3 ms
	Events per hour	≥ 10 s

**Additional references**

Recommended power supply units and tables for calculating power consumption for interconnection with SINAMICS S120 modules can be found in the chapter entitled **Control-Cabinet Construction and EMC Booksize** in the SINAMICS S120 Booksize Power Units Manual.

**9.4.2 Connecting the power supply**

**Wiring the screw-type terminal block**

The required 24 VDC load current supply is wired to screw-type terminal block X124.

 <b>DANGER</b>
The 24 V direct voltage is to be configured as a protective extra low voltage - DVC A or PELV.

**Supply system lines**

Table 9-3 Cable specification for X124

<b>Characteristics</b>	<b>Version</b>
Plug-connector type	Screw-type terminals
Connection possibility	Up to 2.5 mm <sup>2</sup>
Current carrying capacity	Max. 10 A
Max. cable length	10 m

Use flexible cables with a cross section of 0.25 to 2.5 mm<sup>2</sup> (or AWG 23 to AWG 13) for wiring the power supply.

If you only use one wire per connection, a ferrule is not required.

You can use ferrules without an insulating collar in accordance with DIN 46228, Form A long version.

## 9.5 DRIVE CLiQ components

### 9.5.1 DRIVE-CLiQ wiring

The components of the SINAMICS S120 drive family and the control unit are interconnected using DRIVE-CLiQ. When connecting the components, please follow the rules in the documentation below without exception:

The "Connecting components" section of the "Machine Configuration Guidelines" System Manual

#### Cable specification

Table 9-4 Cable specifications for X100 - X103 or X100 – X105

<b>Feature</b>	<b>Specification</b>
Connector type	RJ45 socket
Cable type	DRIVE-CLiQ standard (inside the control cabinet)
	MOTION CONNECT (outside the control cabinet)
Max. cable length	70 m

## 9.5.2 Connectable DRIVE-CLiQ components

### Components

As a rule, all SINAMICS components approved for SINUMERIK can be connected using the DRIVE-CLiQ interface.

Table 9-5 Components with DRIVE-CLiQ

Component	Description
<b>Active/Smart Line Module, Booksize</b>	Line Modules provide the central power supply to the DC link.
<b>Single/Double Motor Module, Booksize</b>	Motor Modules draw their power from the DC link to supply the connected motors.
<b>NX10/15</b>	Drive expansion module for up to 6 axes
<b>SMC10/20/30</b>	Cabinet-Mounted Sensor Modules are needed when a motor with a DRIVE-CLiQ interface is not available and when external encoders are required in addition to the motor encoder.
<b>SME20/25</b>	Measuring systems outside the cabinet can be connected directly to the Sensor Module External.
<b>DMC20/DME20</b>	DRIVE-CLiQ Hub Modules are used to implement star-shaped distribution of a DRIVE-CLiQ line.
<b>TM15</b>	The number of available digital inputs and outputs within a drive system can be expanded with the Terminal Module.

### Additional references

- For information on SINAMICS S120 line modules and Motor Modules, please refer to the
  - Equipment Manual Booksize Power Units
  - Chassis Power Units Equipment Manual
- You can find information on all other modules in the SINAMICS S120 "Control Units and Additional System Components" Manual.

## 9.6 Ethernet

### Application

The following connections can be established via the Ethernet interfaces:

- X120 provides the link to the system network (e.g. operator panels).
- X130 connects the Control Unit to the company network.
- X127 is used for remote diagnostics via teleservice adapter IE.

You can find further details in the following manuals:

- SINUMERIK 840D sl Basesoftware and Operating Software Commissioning Manual
- SIMATIC TS Adapter IE Manual

### Cable specification

Table 9-6 Cable specification for X120, X130, and X127

Characteristics	Version
Plug-connector type	RJ-45 jack
Cable type	Industrial Ethernet cable (CAT5)
Max. cable length	100 m

#### Note

A crossover cable is required for the direct link between the Control Unit and the TCU.

## 9.7 PROFINET

### 9.7.1 Wiring PROFINET

#### Prerequisite

For SINUMERIK 840D sl, a PROFINET system can only be installed with the following Control Units:

- NCU 720.2 PN
- NCU 730.2 PN

## Use

The following communication links can be established via PROFINET interfaces:

- PROFINET CBA:  
Communication between controllers as components in distributed systems
- PROFINET I/O incl. PROFINET IRTE-FLEX:  
Communication between the PLC used for control and the field devices (no NCK access to PROFINET I/O)

## Cable specification

For PROFINET, you always require a data transmission rate of 100 Mbit/s (Fast Ethernet) in full duplex mode. For data transfer purposes, you can use twisted-pair copper cables (4-wire, 100Base-T).

Table 9-7 Cable specification for ports 1, 2

Characteristics	Version
Plug-connector type	RJ45 jack *)
Cable type	Industrial Ethernet cable (CAT5)
Max. cable length	100 m

\*) Please use the Fast Connect connector as outlined in the chapter titled "PROFINET cables (Page 70)".

## 9.7.2 PROFINET cables

### Cable and connector types

---

#### Note

For connecting PROFINET to the NCU we recommend using a connector with a 145° cable outlet (IE FC RJ45 plug 145).

---



Figure 9-3 RJ45 PN connector with a 145° cable outlet

Table 9-8 Connector types for PROFINET

Connector	Designation	Order number
IE FC RJ45 plug 145	RJ45 PN connector with angled exit	6GK1 901-1BB30-0AA0/ 6GK1 901-1BB30-0AB0

Table 9-9 Cable types for PROFINET

Cable	Designation	Order number
IE FC Cable GP 2 (Type A)	4-wire, shielded TP installation cable for IE FC RJ45	6XV1 840-2AH10
IE FC Flexible Cable GP 2 (Type A)	4-wire, shielded flexible TP installation cable for IE FC RJ45	6XV1 870-2B
IE FC Trailing Cable GP 2x2 (Type C)	4-wire TP installation cable for ground cable use	6XV1 870-2D
IE FC Trailing Cable 2x2 (Type C)	4-wire shielded TP installation cable for connection to FC OUTLET RJ45, for ground cable use	6XV1 840-3AH10
IE FC Marine Cable 2x2	4-wire shielded marine-certified TP installation cable for connection to FC OUTLET RJ45	6XV1 840-4AH10

### 9.7.3 Preparing the twisted pair cables

#### Function

The IE FC RJ45 Plugs are used to install uncrossed 100 Mbit/s Ethernet connections up to 100 m without the use of patches. Crossed cables can also be installed by swapping the transmit and receive pair in a plug.

#### Prerequisite

When you set up your PROFINET system, you can cut the AWG 22 twisted pair cable on-site to the required length, strip it with the *Fast Connect Stripping Tool* (for Industrial Ethernet), and fit the *Industrial Ethernet FastConnect RJ-45 Plugs* using the cut-and-clamp technique.

#### Proceed as follows

Contacting of the FC cable versions is simple and reliable with the 4 integrated insulation displacement contacts.

- When the plug case is open, color markings on the contact cover make it easier to connect the cores to the insulation piercing connecting devices. The user can check that contact has been made correctly through the transparent plastic material of the contact cover.
- The stripped end of the cable is inserted in the raised insulation displacement terminals and the terminals are then pressed down to ensure reliable contacting of the conductors.

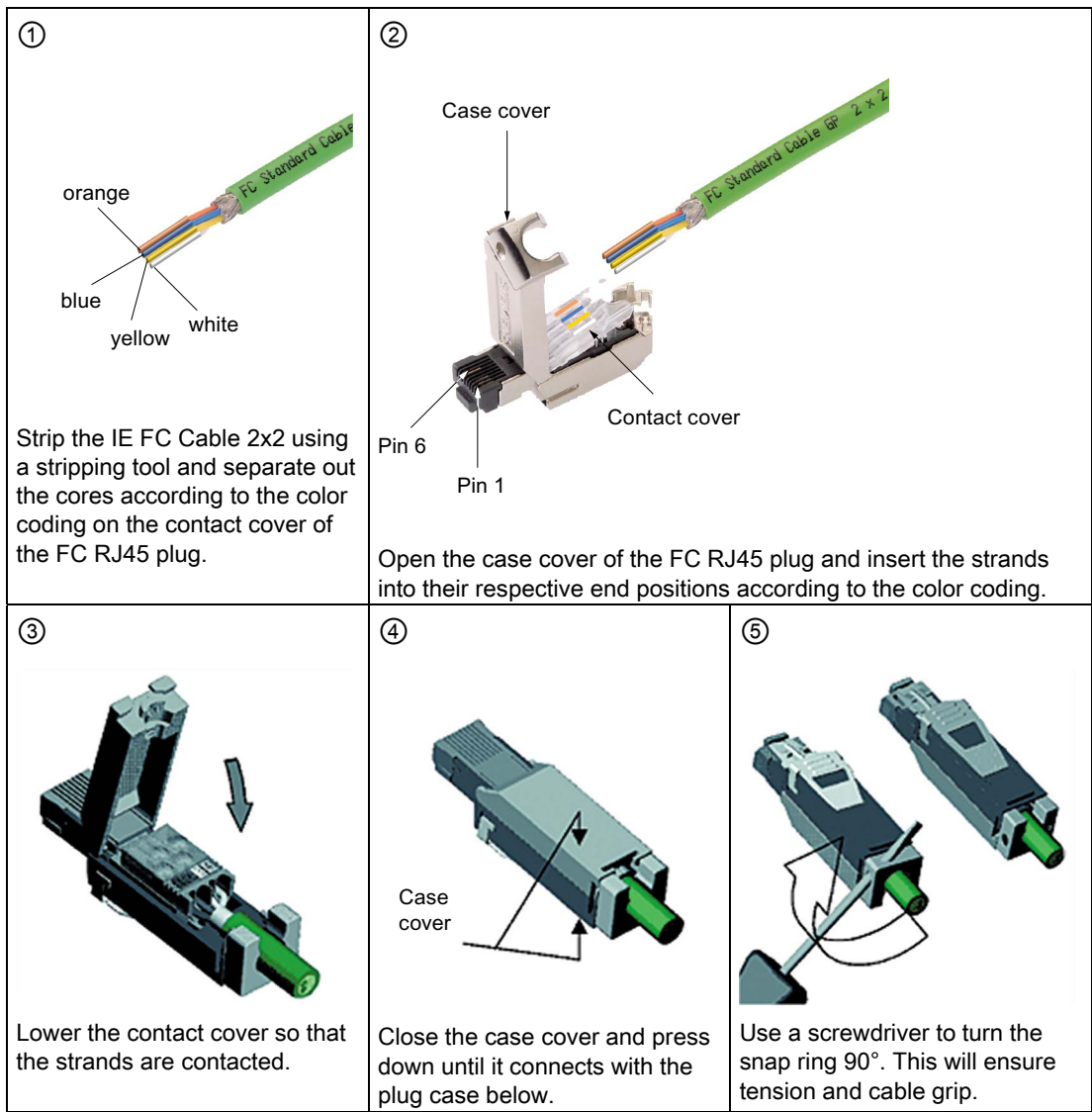

### Assigning the installation cables to the pins on the IE FC RJ45 plug

Between the four individually colored wires of the IE FC RJ45 plug pins, the following assignments are made:

Pin no.	Wire color	Signal name	Meaning
1	yellow	TX+	Transmit data +
2	Orange	TX-	Transmit data -
3	white	RX+	Receive data +
6	blue	RX-	Receive data -



### Additional references

For more information, please refer to:

- The Industry Mall
- The Catalog IK PI
- The manual titled "SIMATIC NET Twisted Pair and Fiber-Optic Networks" (entry ID: 8763736).

### 9.7.4 Example PROFINET CBA configuration

The following figure shows a typical system configuration with PROFINET CBA.

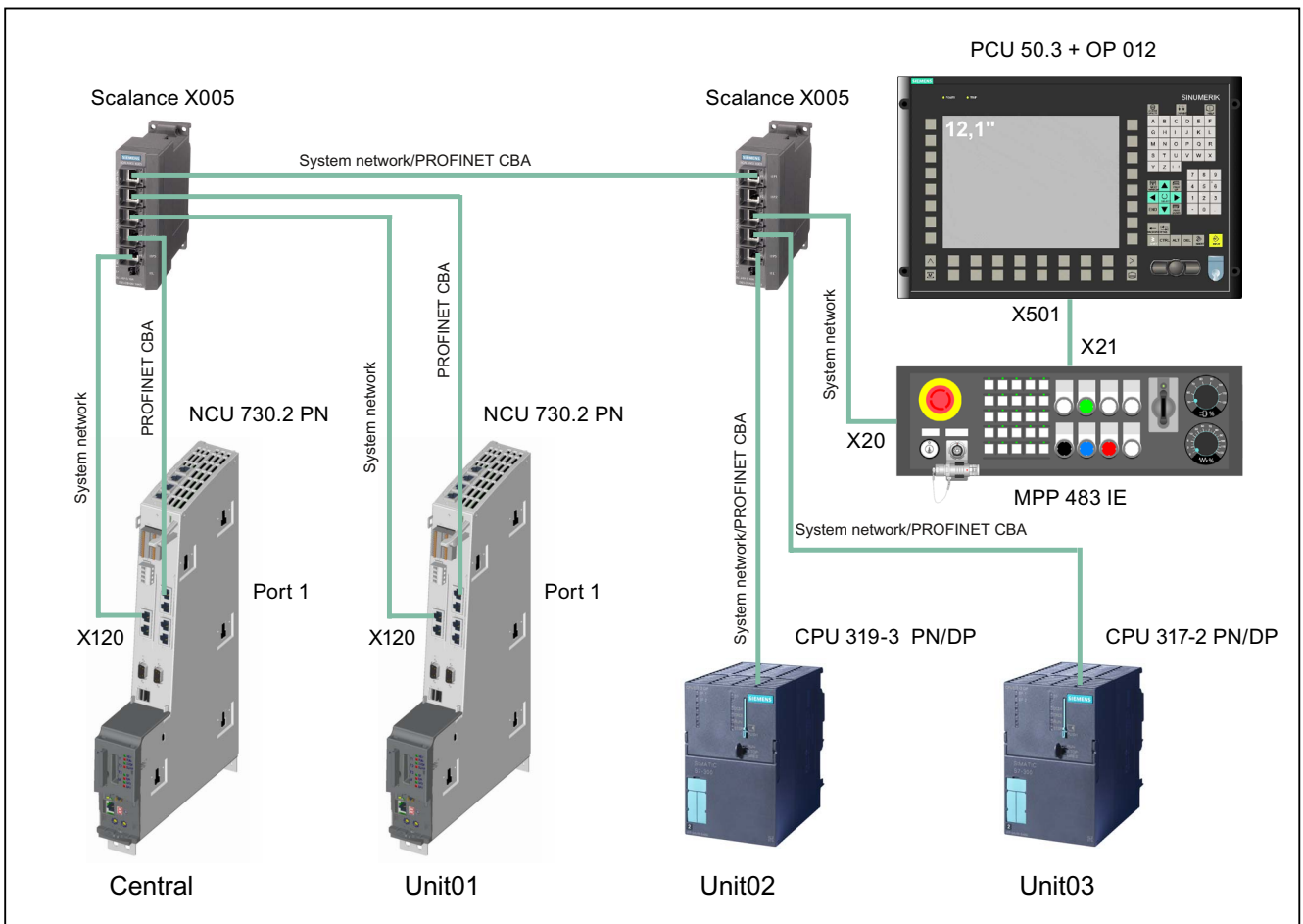

Figure 9-4 Example PROFINET CBA configuration

Station name	Module type	Interface	IP address
Central	NCU 730.2 PN	X120	192.168.200.1
		Port 1	192.168.200.2
	PCU 50.3	X501	192.168.200.5
	MPP 483 IE	X20 DHCP server	192.168.200.50...
Unit01	NCU 730.2 PN	X120	192.168.200.11
		Port 1	192.168.200.12
Unit02	CPU 319-3 PN/DP	PN P1	192.168.200.22
Unit03	CPU 317-2 PN/DP	PN P1	192.168.200.32

## 9.8 PROFIBUS / MPI

### 9.8.1 Application

#### Connectable devices

The following devices can be connected to the PROFIBUS DP interfaces:

- PG/PC
- S7 controllers with PROFIBUS DP interface
- Distributed I/O
- Drive units with PROFIBUS DP interface (standard slaves)

### 9.8.2 PROFIBUS cables and connectors

#### Cable specification

The PROFIBUS cable is 2-wire, twisted, and shielded with defined technical data.

Table 9-10 Cable specification for X126 and X136

Features	Type
Connector type	9-pin SUB-D socket
Cable type	PROFIBUS cable
Max. cable length	100 m for 12 Mbits

Table 9-11 Technical data for PROFIBUS cables

Characteristics	Values
Wave impedance	Approximately 135 to 160 $\Omega$ (f = 3 to 20 MHz)
Loop resistance	$\leq$ 115 $\Omega$ /km
Effective capacitance	30 nF/km
Damping	0.9 dB/100 m (f = 200 kHz)
Permissible conductor cross section	0.3 mm <sup>2</sup> to 0.5 mm <sup>2</sup>
Permissible cable diameter	8 mm + 0.5 mm

### Cable lengths and baud rate

The baud rate determines the cable length of a subnet segment.

Table 9-12 Permitted cable length of a subnet segment for specific baud rates

Baud rate	Max. cable length of a segment (in m)
19.6 to 187.5 kbit/s	1000 <sup>1)</sup>
500 kbit/s	400
1.5 Mbit/s	200
3 to 12 Mbit/s	100

<sup>1)</sup> With isolated interface

#### Longer cable lengths:

If you must realize greater cable lengths than permitted in one segment, you must use RS 485 repeaters. The maximum possible cable lengths between two RS 485 repeaters correspond to the cable length of a segment. You can connect up to 9 RS 485 repeaters in series.

Note that an RS 485 repeater must be counted as a subnet node when determining the total number of nodes to be connected. This is true even if the RS 485 repeater is not assigned its own PROFIBUS address.

### Connector features

The bus connector is used to connect the PROFIBUS cables to the PROFIBUS DP interfaces (X126, X136), thus establishing a connection to additional nodes.

Only bus connectors with a 35° cable outlet should be used in order to ensure that the front cover can be closed.

### 9.8.3 Connection components in PROFIBUS

#### Connection components

Individual nodes are connected by means of bus connectors and PROFIBUS cables. Remember to provide a bus connector with a programming port at either end of the subnet. This will give you the option of expanding the subnet if required, for example, for a programming device.

Use RS 485 repeaters to connect segments or extend cable lengths.

#### Segments

A segment is a bus line between two terminating resistors. A segment may contain up to 32 nodes. In addition, a segment is limited by the permissible cable length, which varies according to the transmission rate.

#### Terminating resistor

A cable must be terminated with its own surge impedance to prevent line disturbances caused by reflections. Activate the terminating resistor at the first and last node on a subnet or segment. The control unit must be either the first or the last node on the subnet.

Make sure that the stations to which the terminating resistor is connected are always supplied with voltage during power-up and operation.

### 9.8.4 Rules for the laying of PROFIBUS cables

#### Laying of bus cables

During laying of the PROFIBUS cable, you must avoid:

- twisting
- stretching and
- squeezing

### Supplementary conditions

During laying of the indoor bus cable, you must also consider the following supplementary conditions ( $d_o$  = outer diameter of the cable):

Table 9-13 Supplementary conditions for the laying of PROFIBUS cables

Features	Supplementary conditions
Bending radius for a single bend	80 mm (10x $d_o$ )
Bending radius (multiple times)	160 mm (20x $d_o$ )
Permissible temperature range for cable routing	-5 °C to +50°C
Temperature range for storage and stationary operation	-30°C to +65°C

### Additional references

For length codes of prefabricated cables and additional information on PROFIBUS cables, refer to "Electrical networks" in the PROFIBUS section of the IK PI catalog titled "Industrial Communication and Field Devices".

## 9.8.5 Connecting PROFIBUS DP

### Introduction

PROFIBUS cables are connected to the X126/X136 interface by means of a bus connector.

### Wiring the bus connector

1. Proceed as follows to connect the bus connector:
2. Plug the bus connector into the corresponding interface on the control unit.
3. Screw the bus connector into place.

As the control unit is located at the start or end of a segment, you must switch on the terminating resistor ("ON" switch setting).



Figure 9-5 Terminating resistor switched on and off

### Note

Make sure that the stations on which the terminating resistor is located are always supplied with voltage during booting and operation.

## 9.8.6 Disconnecting stations from the PROFIBUS

### Removing the bus connector

You can remove the bus connector with a looped-through bus cable from the PROFIBUS DP interface at any time without interrupting data traffic on the bus.

 **WARNING**

**Data exchange on the bus can be interrupted!**

A bus segment must always be terminated with the terminating resistor at both ends. This is not the case, for example, if the last node with a bus connector is de-energized. Because the bus connector takes its voltage from the node, this terminating resistor is ineffective.

Make sure that the nodes at which the terminating resistor is connected are always energized.

## 9.8.7 Operating the X136 interface as MPI

### Applications

The X136 interface can also be operated as an MPI interface instead of a PROFIBUS DP interface. The typical (default) baud rate is 187.5 Kbaud. A baud rate of up to 12 Mbaud can be set for communication with other CPUs. It should be noted, however, that a rate of 12 Mbaud is not supported by all CPUs (e.g. smaller SIMATIC S7 CPUs).

The following list provides examples of when using MPI (multi-point interface) may prove effective:

- If a PC/PG with an MPI is being used
- If an MPI-type handheld unit is being used

### Operate MPI like PROFIBUS

The information on wiring the connector (terminating resistors) for PROFIBUS and the rules on the laying of cables for PROFIBUS apply to this interface as well. When carrying out this procedure, consult the relevant references.

## Connector features

The bus connector is used to connect the MPI bus cable to the MPI (X136). This enables you to establish connections to additional nodes (e.g. PG or SIMATIC S7-CPU). Only bus connectors with a 35° cable outlet should be used in order to ensure that the front cover can be closed.

## MPI bus cable

The PROFIBUS cable specifications apply here as well. Please note the relevant information on setting up an MPI network.

## Setting up an MPI network

Keep in mind the following basic rules when setting up an MPI network:

- When using the interface as an MPI interface, it is not possible to arrange additional control for a drive in isochronous mode or to connect distributed I/Os to this interface.
- An MPI bus line must be terminated at both ends. This is achieved by activating the terminating resistor in the MPI connector in the first and last station and deactivating the other terminating resistors.
- At least one terminator must be supplied with 5 V.  
This means that an MPI connector with an activated terminating resistor must be connected to a device that is switched on.
- Spur lines (cables leading from the bus segment to the node) should be as short as possible, i.e. < 5 m in length. Unused spur lines should be removed wherever possible.
- Every MPI station must be connected to the bus first and then activated.  
To disconnect the station, it must first be deactivated. Then, the station can be removed from the bus.
- Maximum cable lengths:
  - 200 m per bus segment
  - 2000 m total length with RS 485 repeaters

## 9.9 Digital inputs/outputs

### 9.9.1 Application

#### Connecting sensors and actuators

Digital inputs and outputs can be used to connect various sensors and actuators to the two 12-pin connectors (X122 and X132) on the front panel.

The following types of digital I/O are used:

- Digital inputs
- Bidirectional digital inputs/outputs

The assignment of I/Os to functions can be parameterized freely by the user. Special functions, such as probe inputs (rapid inputs only) and cam outputs, can also be assigned to the inputs/outputs.

The enables for the drive units and/or motors (Line Module, Motor Module) connected to the control unit can be switched using the digital inputs.

For further information on NCU 7x0 and NX 1x terminal assignment, see:

- The "Communication in the system" section of the "Machine Configuration Guidelines" System Manual
- The "IBN CNC: NCK, PLC, Drive" Commissioning Manual ("Tips" section)

#### Access to digital inputs/outputs

---

##### Note

The digital inputs/outputs are updated in accordance with the set PROFIBUS bus clock pulse for SINAMICS Integrated.

---



### Block diagram

The following figure shows the block diagram for the digital inputs/outputs of a Control Unit.

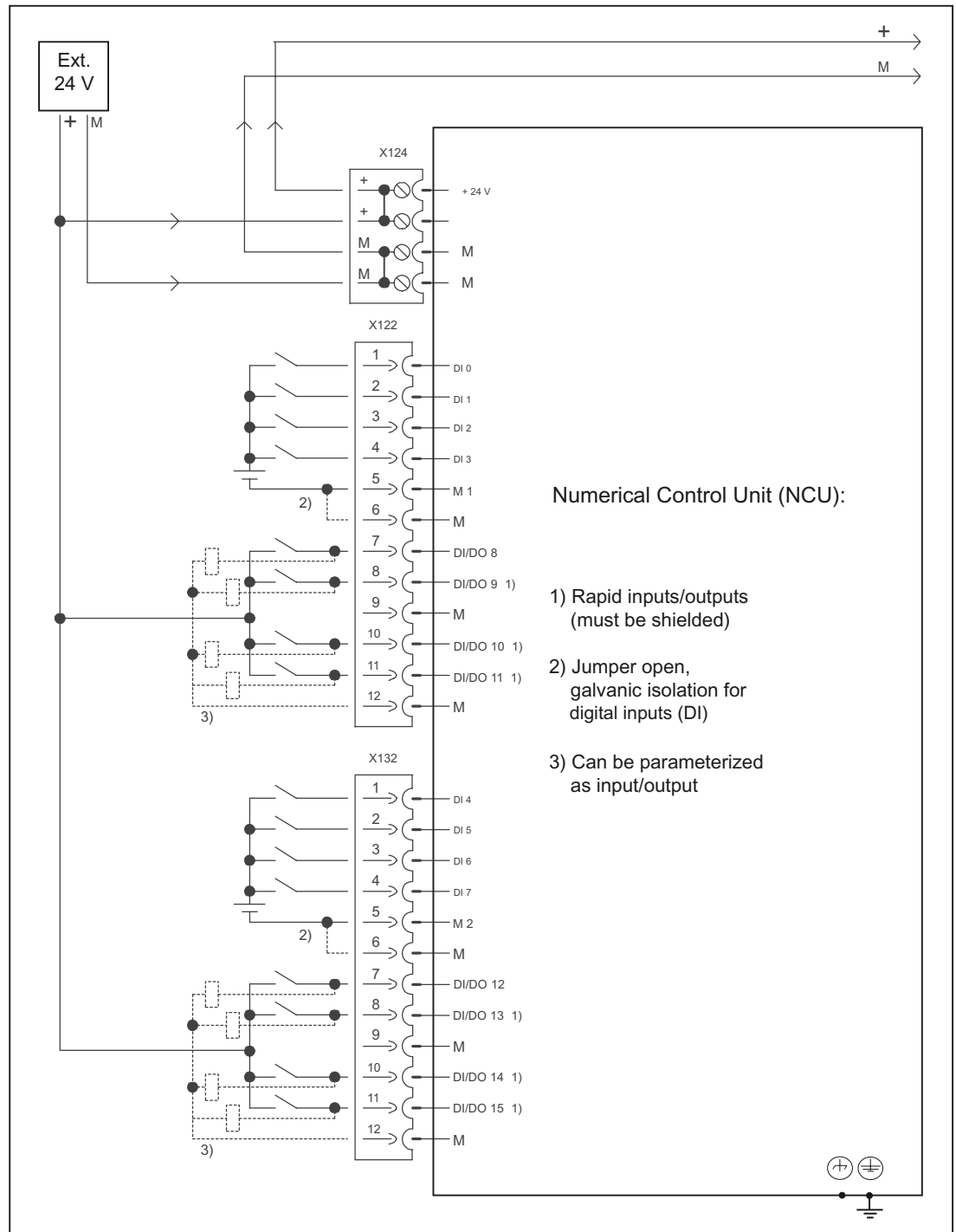

Figure 9-6 Block diagram for digital inputs/outputs

## 9.9.2 Connecting digital inputs/outputs

### Cable specification

Table 9-14 Cable specification for X122 and X132

Characteristics	Specification
Connector type	Screw-type terminals
Connection option	Up to 0.5 mm <sup>2</sup>
Current carrying capacity	4 A max.

### Connecting cables for digital inputs/outputs

The following conditions apply to connecting cables:

- Use flexible cables with a cable cross-section of at least 0.25 mm<sup>2</sup>
- Ferrules are not required.

---

#### Note

To achieve optimum interference suppression, shielded cables must be used to connect measuring inputs or BEROs.

---

### Tools required

3.5-mm screwdriver or power screwdriver

### Wiring digital inputs/outputs

1. Strip 6 mm of insulation from the wires.
2. Wire the digital inputs of the interface for connection of the sensors.
3. Wire the digital outputs of the interface for connection of the actuators.
4. Insert the cable into the corresponding spring-loaded terminal.

### Using shielded cables

The following options are available for the shield connection when using shielded cables:

1. Attach the cable shield to a grounded shielding bus immediately after the cable entry point in the cabinet (strip the insulation off the cable for this purpose).
2. Continue routing the shielded cable as far as the module but do not make a connection to the shield there.

**Using a shield connection**

1. Remove the fixing bracket.
2. Insert the cable and fasten the fixing bracket.

This figure shows where to attach the cables to the front panel connector and where to apply the cable interference suppression using the shield connecting element.

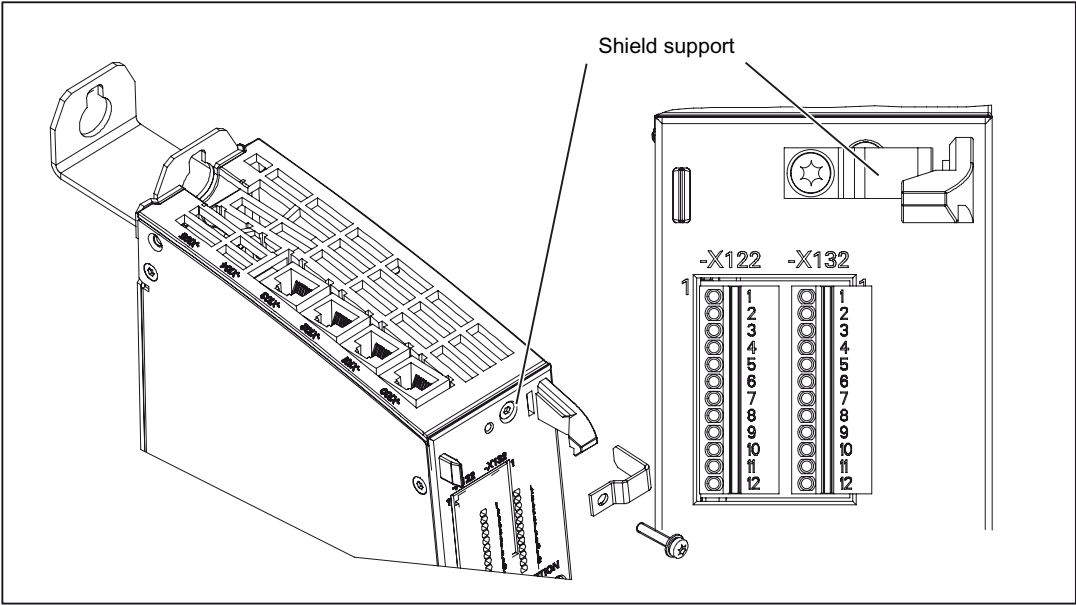

Figure 9-7 Using a shield connection

**9.10 USB**

The USB interfaces are used exclusively for service purposes, correspond to the norm and are, therefore, not described in detail here.

Table 9-15 Cable specification for X125 and X135

Characteristics	Versions
Connector type	Double USB socket – type A
Version	USB 2.0
Current carrying capacity	0.5 A per channel
Max. cable length	5 m

**Note**

The 5 V power supply is designed to be short-circuit proof.

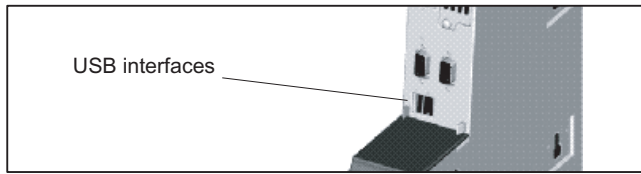

Figure 9-8 Position of USB interfaces

## 9.11 Measuring sockets

### Application

The test sockets are used to output analog signals. Any interconnectable signal can be output to any test socket on the control unit.

- Max. output range of the test signal: 0 to 5 V
- Test sockets have to be parameterized before use, as there is no default setting on delivery.

**! CAUTION**

The test sockets should be used exclusively for servicing purposes.  
The measurements may only be carried out by appropriately trained specialists.

### Test socket position

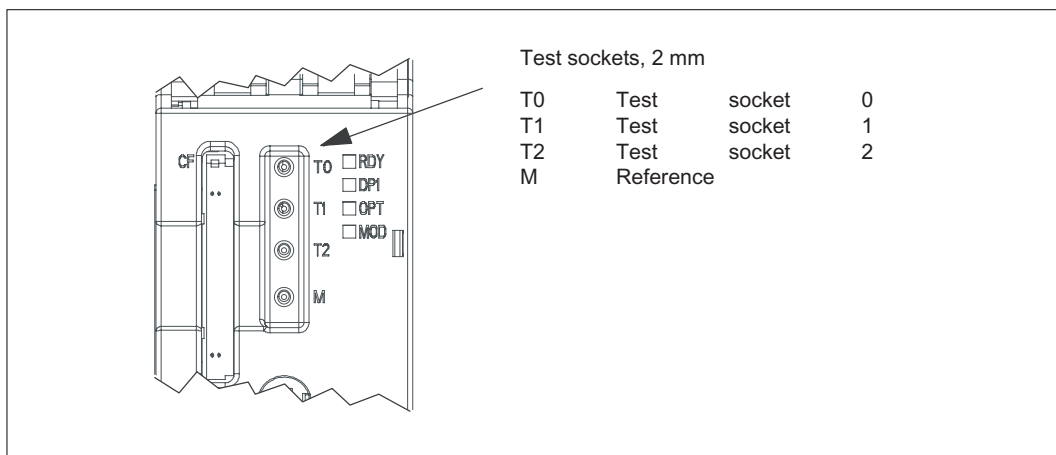

Figure 9-9 Test socket arrangement

Table 10-1 General technical data

<b>Safety</b>	
Protection class	I (protective conductor) as per EN 61800-5-1
Degree of protection to EN 0529	IP20 or IPXXB with option slot cover or option module inserted
Certifications	CE, cULus
Pollution degree	2
Cooling	Open-circuit-ventilated
Mounting position	Vertical
<b>Mechanical environmental conditions</b>	
Transportation (in transportation packaging)	2M3 according to EN 60721-3-2
Storage	1M2 according to EN 60721-3-1

Table 10-2 Electrical and mechanical data (1)

	<b>NCU 710.2</b>	<b>NCU 720.2</b>	<b>NCU 720.2 PN</b>
Main memory	512 MB DRAM 1 MB SRAM	1 GB DRAM 1 MB SRAM	1 GB DRAM 1 MB SRAM
SIMATIC S7 - integrated	PLC 317-2 DP	PLC 317-2 DP	PLC 319-3 PN/DP
Input voltage	24 VDC	24 VDC	24 VDC
Power consumption, max.	170 W	174 W	216 W
Power loss	22 W	25 W	55 W
Dimensions (WxHxD)	50 x 455 x 272 mm	50 x 455 x 272 mm	50 x 455 x 272 mm
Weight, approx.	2.9 kg	2.9 kg	3.8 kg

Table 10-3 Electrical and mechanical data (2)

	<b>NCU 730.2</b>	<b>NCU 730.2 PN</b>
Main memory	1 GB DRAM 1 MB SRAM	1 GB DRAM 1 MB SRAM
SIMATIC S7 - integrated	PLC 317-2 DP	PLC 319-3 PN/DP
Input voltage	24 VDC	24 VDC
Power consumption, max.	216 W	225 W
Power loss	55 W	65 W
Dimensions (WxHxD)	50 x 455 x 272 mm	50 x 455 x 272 mm
Weight, approx.	3.6 kg	3.8 kg



## Spare Parts/Accessories

### 11.1 Dual fan/ battery module

#### 11.1.1 Application

##### Functions of the dual fan/battery module

The dual fan/battery module can perform the following tasks:

- Cooling the CPU by means of two redundant fans.
- SRAM buffering if the SuperCap is insufficient.

The Control Unit monitors the temperature inside the module and the functioning of the fan. Fan faults are displayed and can be read out by means of the diagnostic buffer.

- Fan warning: When one of the two fans has ceased to turn.
- Fan fault: When none of the fans turn.  
If the software does not respond within approx. 1 minute the components are shutdown automatically and the status is indicated by means of the red SF LED.

#### Fans

If natural convection is not sufficient to ensure heat dissipation for the the NCU 710.2/720.2/730.2, the fans integrated in the dual fan/battery module will be activated when required.

- After switching the NCU on, the fan will be activated for a brief period (for testing purposes) before turning itself off again.
- A temperature sensor on the NCU will switch the fan on if the air intake temperature exceeds approximately 40°C.
- The fans will be switched off when the air intake temperature falls back below approx. 35°C.
- The fan is monitored during operation. In the event of a fault (stalled rotor or running too slowly) a message is output.

Fans on the following Control Units run permanently:  
NCU 720.2 PN and NCU 730.2 PN

NOTICE
The Control Unit cannot be operated without fans, i.e. the Control Unit will not power up if the dual fan/battery module is not functioning.

## Battery

A 3 V lithium battery can be inserted in the dual fan/battery module. The battery is pre-assembled with an approximately 4 cm long cable with plug connector. The appropriate mating connector is attached to a small circuit board for connection in the dual fan/battery module.

### Note

Please dispose of used batteries in the specially provided collection points on site. This will ensure they are reused in the correct manner or treated as special waste.

### NOTICE

The backup time of a used type of battery is at least 3 years. Exceeding this backup time risks loss of data.

## 11.1.2 Mounting

### Position of the dual fan/battery module

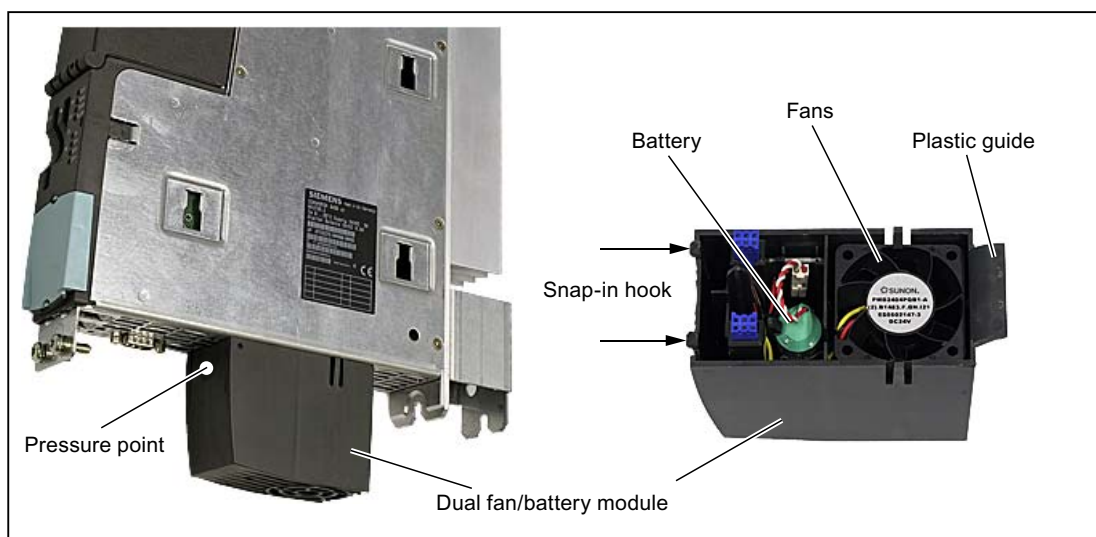

Figure 11-1 Replacing the dual fan/ battery module



**Proceed as follows**

Proceed as follows to replace the dual fan/battery module but only observe points 3 and 4 if you want to replace the battery as well:

1. Gently push the dual fan/battery module backwards (by pressing on the pressure point) to release the module from its front interlock (snap-in hooks).

**CAUTION**

Never pull the dual fan/battery module out abruptly without having released the interlock. This would break the snap-in hooks and you would not be able to reinsert the module.

2. Tilt the dual fan/battery module forwards at an angle and pull out the plastic guide from the Control Unit cutout.
3. Remove the battery by first removing the plug connector and then taking out the battery.
4. Connect the cable plug connector of the new battery to the mating connector in the dual fan/battery module and push the battery in.

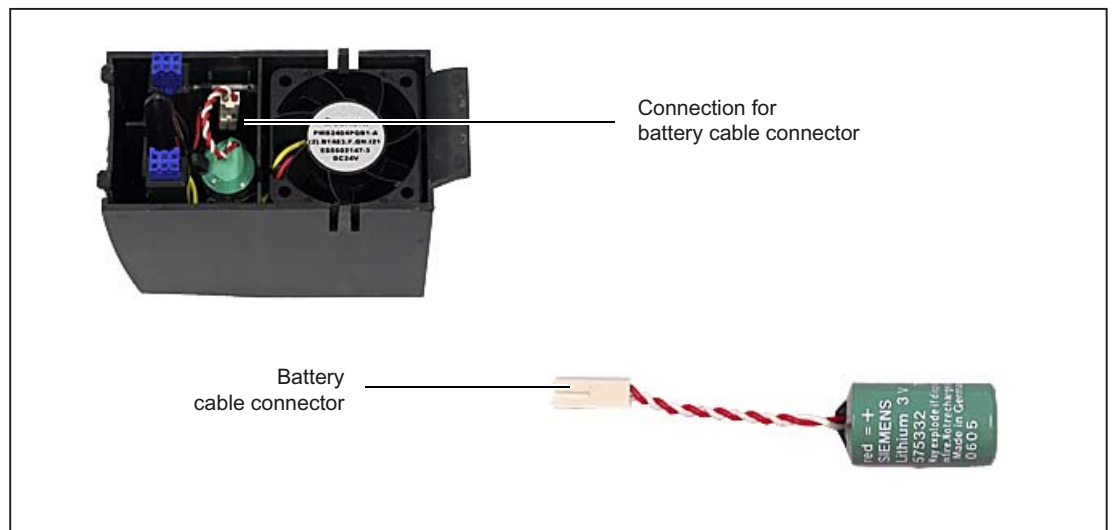

Figure 11-2 Battery replacement in the dual fan/battery module

5. Tilt the dual fan/battery module forwards at an angle with the open side facing up (battery visible).
6. Push the plastic guide into the cutouts on the underside of the Control Unit.
7. Tilt the dual fan/battery module up until the front interlock snaps into place.

The electrical connection between the dual fan/battery module and the Control Unit is established automatically.

**NOTICE**

To avoid loss of data, the dual fan/battery module must be replaced during operation. When doing this, observe that the Control Unit can only be operated for a maximum of 1 minute without fans. If this time is exceeded, the Control Unit will shut itself down.

## 11.2 NX10/15

### 11.2.1 Description

#### Properties

Using this module, you can expand the performance of an axis grouping of the SINUMERIK 840D sl CNC automation system. Each NX10 can control up to 3 additional axes and each NX15 can control up to 6 additional axes.

The NX10/15 has the following interfaces:

- 4 DRIVE-CLiQ (X100 – X103)
- 4 digital inputs and 4 digital inputs/outputs (X122)
- Power supply (X124)

## Display

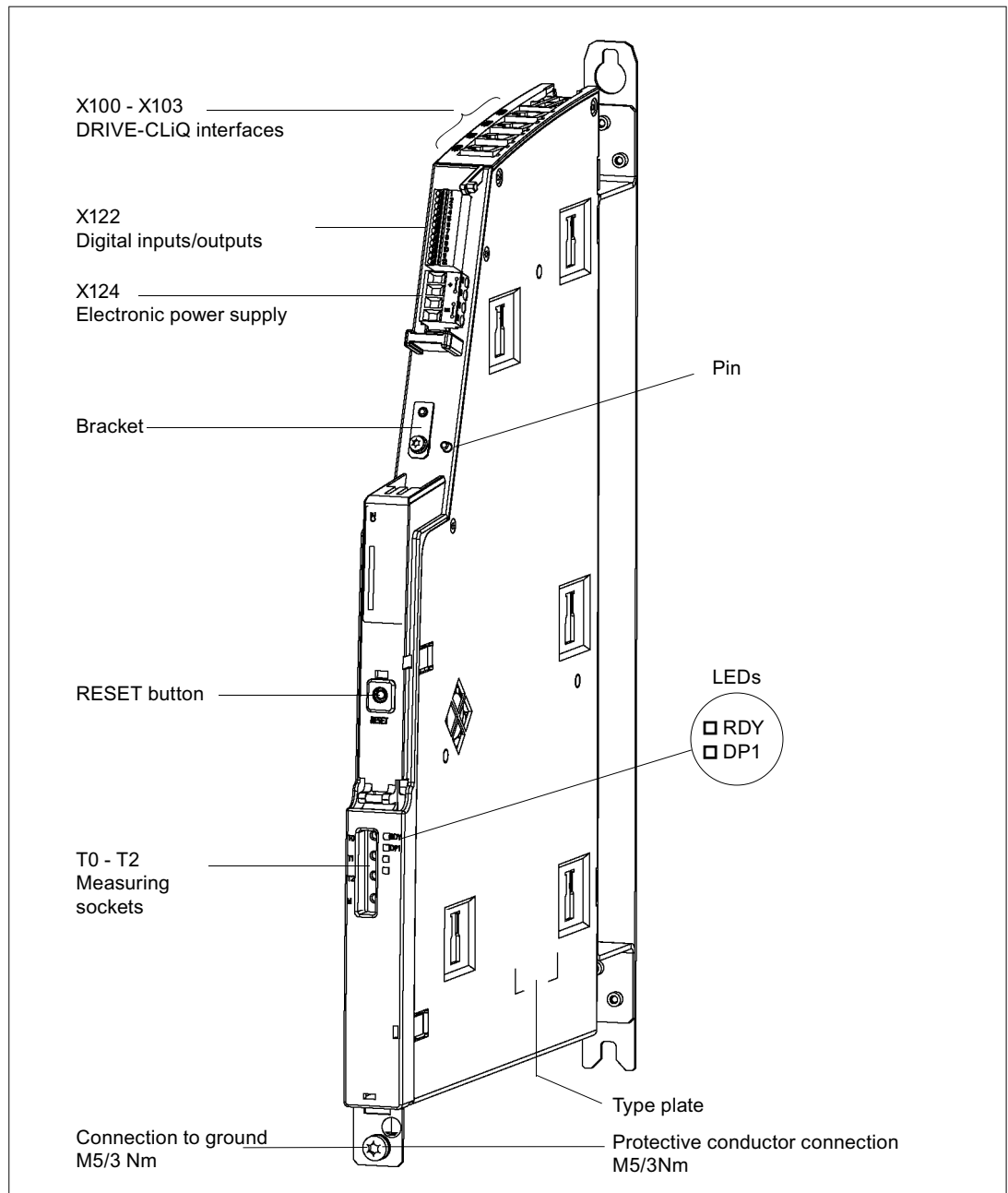

Figure 11-3 Representation of NX10/15 (without cover)

## Type plate

The NX10/15 module type plate contains basically the same information as the control unit type plate (see Section 4.4).

## 11.2.2 Operating and display elements

### LED displays

Table 11-1 Description of LEDs on the NX10/15

LED	Color	Status	Description
RDY, READY H1	Off		Electronic power supply outside permissible tolerance range
	Green	Steady-light signal	NX10/15 is ready for operation
		Blinklight 2 Hz	Writing to CompactFlash Card
	Red	Continuous light	At least one fault is pending (e.g., RESET, watchdog monitoring, basic system fault). NX10/15 is booting up.
		Blinklight 0.5 Hz	Boot fault (e.g., firmware cannot be loaded into the RAM)
	Orange	Continuous light	Firmware loading into RAM
		0.5 Hz flashing light	Unable to load firmware into RAM
2 Hz flashing light		Firmware CRC fault	
DP1, CU_LINK H2	Off		Electronic power supply outside the permissible tolerance range, NX10/15 is not ready for operation.
	Green	Continuous light	CU_LINK is ready for communication and cyclic communication is running
		0.5 Hz flashing light	CU_LINK is ready for communication and no cyclic communication is running
	Red	Continuous light	At least one CU_LINK fault is present. CU_LINK not ready for operation (e.g., after POWER ON)

#### RESET button

The RESET button is on the front of the module under the cover.

#### NOTICE

When the pushbutton is actuated, the locally connected drive systems are brought to a standstill with no feedback to the control. In other words, the drive and control run asynchronously once the drive has successfully booted up.

### 11.2.3 Interfaces

#### Power supply X124

Table 11-2 Pin assignment for X124

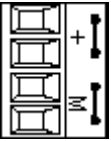
	Terminal	Function	Technical specifications
	+	Electronics power supply	Voltage: 24 V DC (20.4 V - 28.8 V) Current consumption: max. 0.8 A (without load) Max. current via jumper in connector: 20 A at 55 °C
	+	Electronics power supply	
	M	Electronic ground	
	M	Electronic ground	
Max. connectable cross-section: 2.5 mm <sup>2</sup> Type: Screw-type terminal			

#### Note

The two "+" and "M" terminals are jumpered in the connector and not in the device. This ensures that the supply voltage is looped through.

The current consumption increases by the current consumption of DRIVE-CLiQ and the digital outputs.

#### DRIVE-CLiQ interfaces X100 - X103

Table 11-3 Characteristics of X100 - X103

Features	Specification
Connector type	DRIVE CLiQ plug connector
Cable type	DRIVE-CLiQ standard (inside the control cabinet)
	MOTION CONNECT (outside the control cabinet)
Max. cable length	70 m

Table 11-4 Pin assignment for X100 - X103

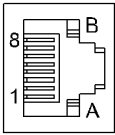
	Pin	Signal name	Technical specifications
	1	TXP	Transmit data +
	2	TXN	Transmit data -
	3	RXP	Receive data +
	4	Reserved, do not use	
	5	Reserved, do not use	
	6	RXN	Receive data -
	7	Reserved, do not use	
	8	Reserved, do not use	
	A	+ (24 V)	Power supply
	B	GND (0 V)	Electronic ground
Dust cover for DRIVE-CLiQ interface: Tyco, order no.: 969556-5			

## X122 Digital inputs/outputs

Table 11-5 Interface characteristics of X122

Characteristics	Specification
Connector type	Screw-type terminals
Connection option	Up to 0.5 mm <sup>2</sup>
Current carrying capacity	4 A max.

Table 11-6 Pin assignment for X122

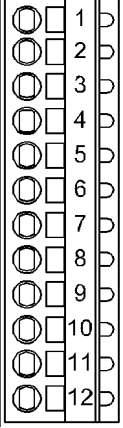
	Terminal	Designation <sup>1)</sup>	Technical specifications
	1	DI 0	Voltage: -3 V to 30 V
	2	DI 1	Typical current consumption: 10 mA at 24 V DC
	3	DI 2	Isolation: The reference potential is terminal M1
	4	DI 3	Signal level (incl. ripple)
	5	M1	High signal level: 15 V to 30 V
	6	M	Low signal level: -3 V to 5 V
	7	DI/DO 8	Signal propagation times: L → H: approx. 50 μs H → L: approx. 100 μs
	8	DI/DO 9	As input: Voltage: -3 V to 30 V
	9	M	Typical current consumption: 10 mA at 24 V DC
	10	DI/DO 10	Signal level (incl. ripple)
	11	DI/DO 11	High signal level: 15 V to 30 V
	12	M	Low signal level: -3 V to 5 V

1) DI: digital input; DI/DO: Bidirectional digital input/output; M: Electronics ground M1: Reference ground

### Note

An open input is interpreted as "low".

The "rapid inputs" can be used for positioning measurement and as probe inputs depending on the terminal assignment used.

To enable digital inputs (DI) 0 to 3 to function, terminal M1 must be connected. This can be done as follows:

Connect the coupled-motion ground reference of the digital inputs or provide a jumper to terminal M. **(Notice! This removes the galvanic isolation for these digital inputs.)**

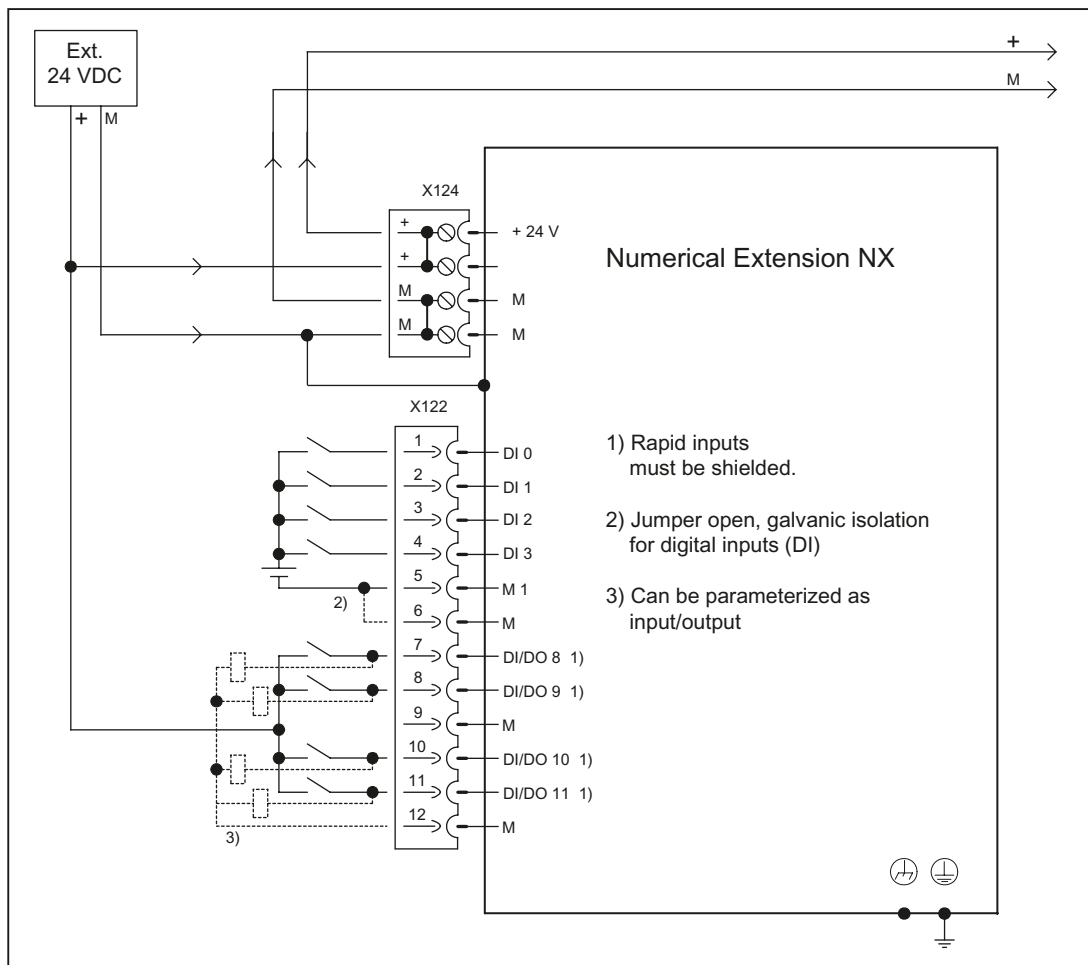

Figure 11-4 Block diagram for digital inputs/outputs

**Note**

The digital inputs/outputs are reserved by the system (terminal assignment).



11.2.4 Dimension drawing

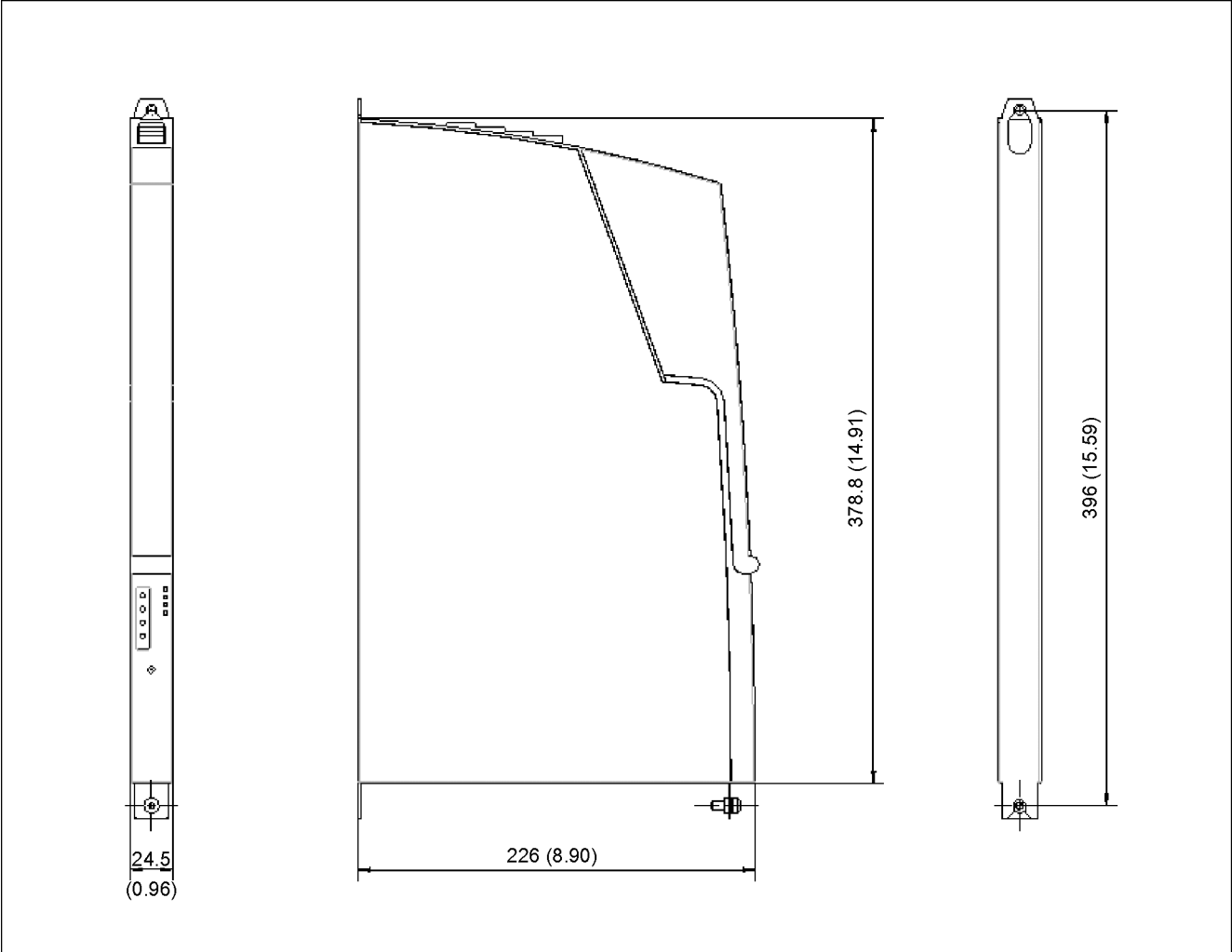

Figure 11-5 NX10/15 dimension drawing

### 11.2.5 Mounting

#### Mounting aids

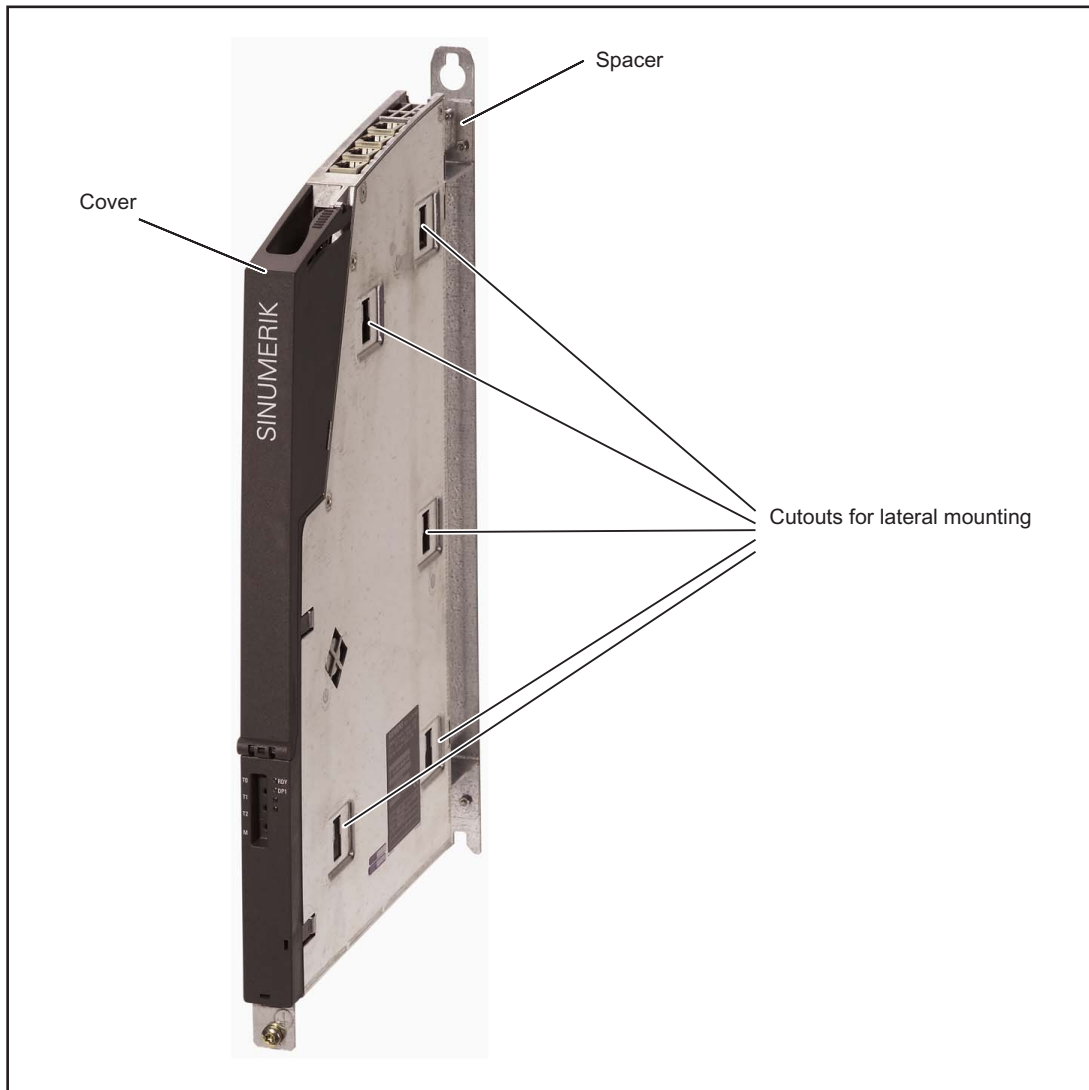

Figure 11-6 NX10/15 mounting aids

#### Designs

Basically, the NX10/15 is integrated into the SINAMICS drive line-up in exactly the same way as the Control Unit (see Chapter 8, Mounting).

- Lateral mounting of NX 10/15 on the SINAMICS drive line-up
- NX 0/15 directly on the rear wall of the control cabinet

Preferred call sequence: The NX modules should be inserted between the Line Module and the control unit.

<b>CAUTION</b>
The 80 mm ventilation spaces above and below the components must be observed.

**Mounting an NX10/15 on another NX10/15**

Table 11-7 Mounting an NX10/15 on another NX10/15

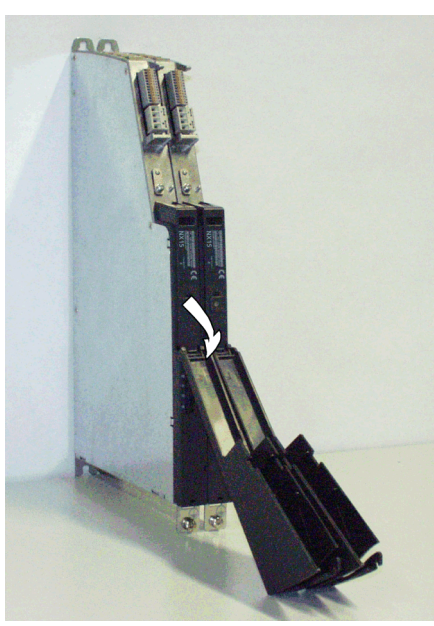
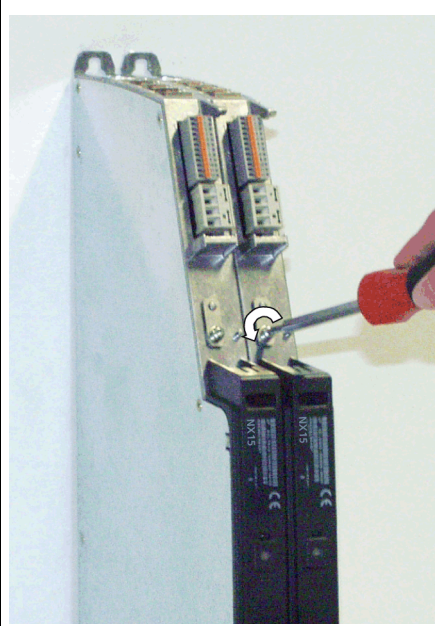
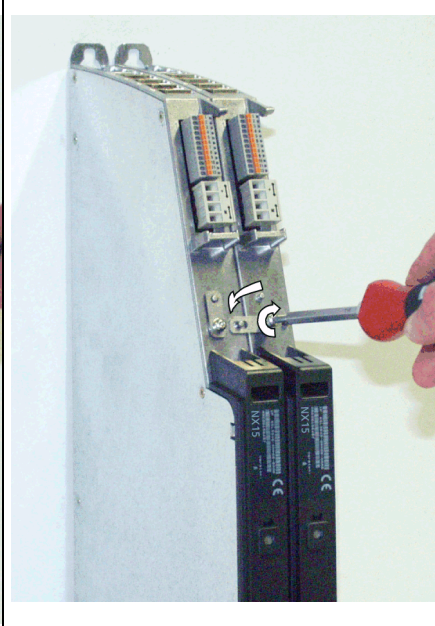
		
Opening the cover.	Unscrewing the screw.	The bracket must be moved so that the pin is in the opening of the bracket. Tighten the screw.

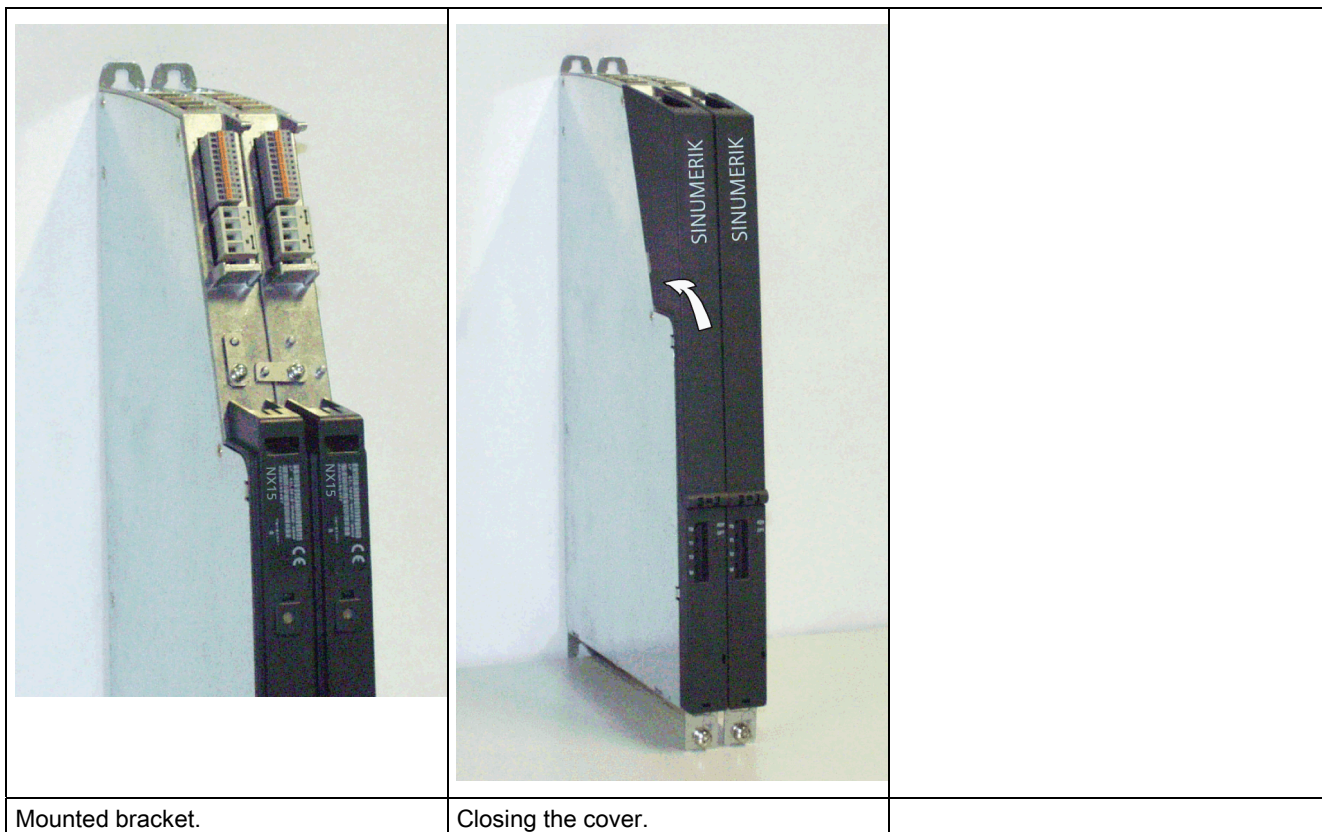

### 11.2.6 Port

#### NX10/15 DRIVE-CLiQ topology

NX10/15 components can be connected to the control unit via DRIVE-CLiQ. The following rules apply to wiring of the NX10/15:

- Only one **star topology** is permitted between the NX10/15 and the control unit. This means that only one NX10/15 can be operated per DRIVE-CLiQ port on a control unit.
- DRIVE-CLiQ ports not assigned to NX10/15 can be wired to other DRIVE-CLiQ components.
- Once an NX10/15 has been connected and configured, you cannot simply insert it into a different DRIVE-CLiQ port, as the addresses of the integrated drives are set permanently from the point of view of the PLC. The following table illustrates this relation:

Table 11-8 NX10/15 PROFIBUS addresses

DRIVE-CLiQ port on the NCU	Drive PROFIBUS addresses
X105	15
X104	14
X103	13
X102	12
X101	11

The following figure shows a sample topology:

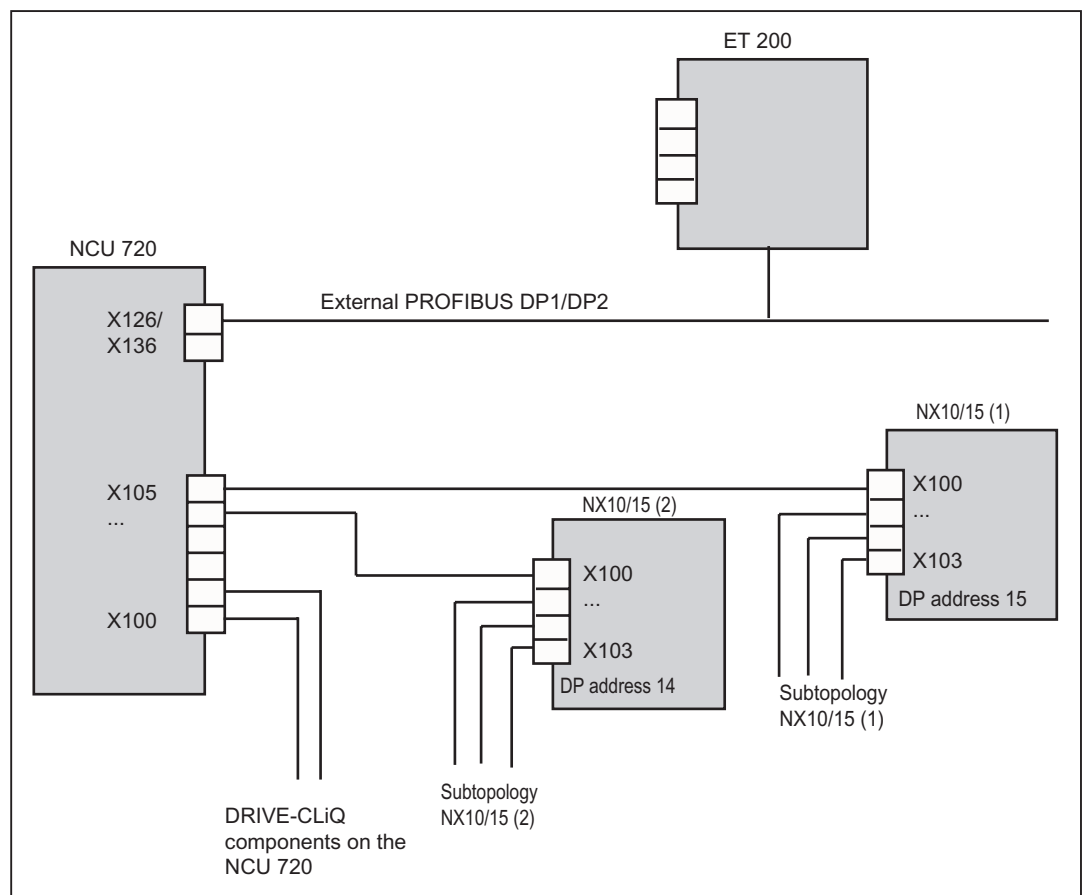

Figure 11-7 NX10/15 topology

### Additional references

For information on commissioning NX components, please refer to the "IBN CNC: NCK, PLC, drive Commissioning Manual".

## 11.2.7 Technical Data

Table 11-9 Technical data

Parameters	Values
Input voltage	24 V DC (20.4 – 28.8)
Current (without DRIVE-CLiQ or digital outputs)	0.8 A
PE/ground connection	On housing with M5/3 Nm screw
Dimensions (WxHxD)	24.5 x 396 x 226 mm
Weight	1.5 kg
Mounting position	Vertical

## 11.3 RS 232C (V.24) module COM01

### 11.3.1 Description

The RS 232C (V.24) module COM01 can be inserted in the option slot on the following control units:

- NCU 710.2
- NCU 720.2
- NCU 730.2

The control units can be connected to a master computer or modem via COM port X491. The COM port has been designed in accordance with the "ANSI/EIA/TIA-232-F-1997" standard.

## Representation of the RS 232C (V.24) module COM01

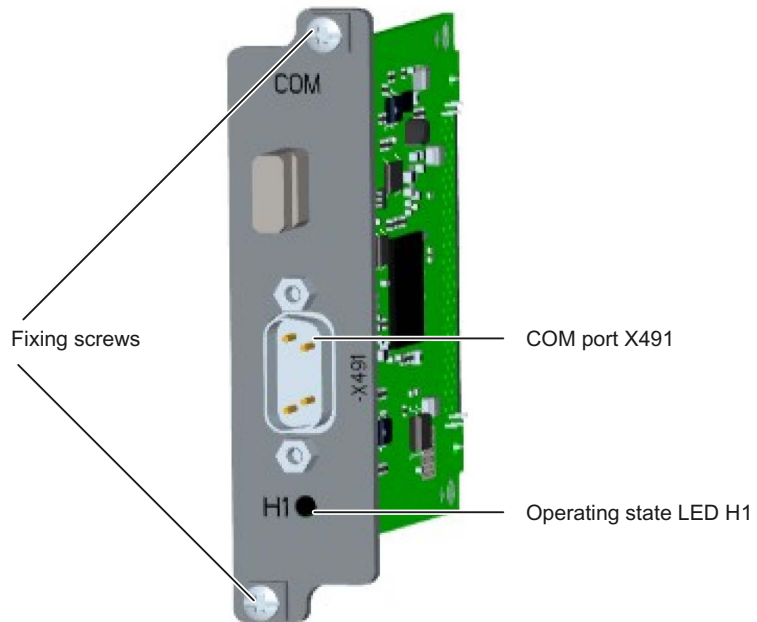

Figure 11-8 RS 232C (V.24) module COM01

### 11.3.2 Operator controls and displays

#### LED displays

LED H1 is located under the COM port. This can display the following operating states:

Table 11-10 LED displays, H1

Color	State	Meaning
Orange	Is lit	Module is ready; after reset.
Green	Is lit	Module is active.
Red	Is lit	Operating error

### 11.3.3 Interfaces

The RS 232C (V.24) module has a standardized serial interface.

#### Properties

COM port X491 is opto-uncoupled.

#### Cable specification

Table 11-11 Cable specification for COM port X941

Characteristic	Specification
Connector type	9-pin SUB-D socket; pin
Cable type	Prefabricated signal line RS 232C/V.24 (9-pin - 9-pin)
Order number	6FX8002-1AA01
Max. cable length	15 m

#### Pin assignment

Table 11-12 COM port X491

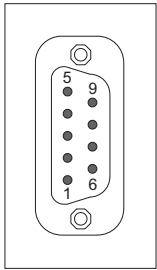
	Pin	Signal name	Signal type	Meaning
	1	DCD	Input	Receiver signal level
	2	RXD	Input	Serial receive data
	3	TXD	Output	Serial transmit data
	4	DTR	Output	Data terminal equipment ready
	5	GND	-	Ground (reference potential)
	6	DSR	Input	Readiness for operation
	7	RTS	Output	Request To Send
	8	CTS	Input	Clear To Send
	9	RI	Input	Incoming call



### 11.3.4 Installation/Mounting

**CAUTION**

Option modules should only be inserted and removed when the Control Unit and option module are at zero current.

**CAUTION**

Option modules may only be operated by qualified personnel. The ESD notices must be observed.

#### Installing RS 232C (V.24) module COM01

A COM01 option module is installed in the option slot of the control unit.

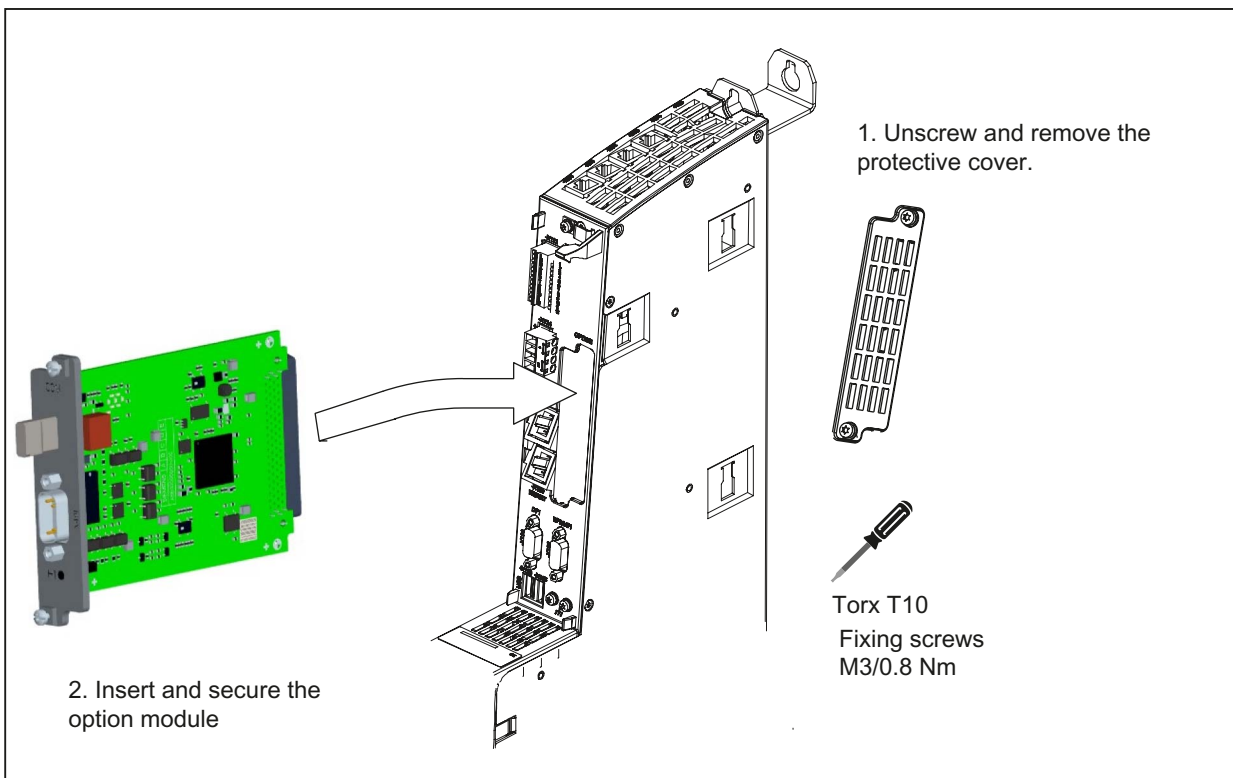

Figure 11-9 Installing COM01

The cable outlet is at the top.

## 11.4 TM15 Terminal Module

### Properties

Terminal Module TM15 provides drive-related digital inputs and outputs with short signal delay times. TM15 is connected by means of DRIVE-CLiQ.

Each of the 24 isolated DI/O can be parameterized channel-by-channel as a digital input (DI), digital output (DO), measuring input, or output of the output cam.

### Additional references

You can find additional information on the TM15 in the SINAMICS S120 manual titled "Control Units and Additional System Components".

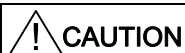

The 50 mm clearances above and below the components must be observed.

## 11.5 DRIVE-CLiQ Hub Module DMC20

### Properties

The DRIVE-CLiQ DMC20 Hub Module is used to implement point-to-point distribution of a DRIVE-CLiQ line. With the DMC20, an axis grouping can be expanded with 4 DRIVE-CLiQ sockets for additional subgroups.

The module is especially suitable for applications which require DRIVE-CLiQ nodes to be removed in groups, without interrupting the DRIVE-CLiQ line and therefore the data exchange.



The 50 mm clearances above and below the components must be observed.

### Additional references

You can find further information on the DMC20 in the SINAMICS S120 manual titled "Control Units and Additional System Components".

## 11.6 DME20 DRIVE-CLiQ Hub Module

### Properties

The DME20 DRIVE-CLiQ Hub Module is used to implement point-to-point distribution of a DRIVE-CLiQ line. With the DME20, an axis grouping can be expanded with 5 DRIVE-CLiQ sockets for additional subgroups.

The component has degree of protection IP67 and is especially suitable for applications which require DRIVE-CLiQ nodes to be removed in groups, without interrupting the DRIVE-CLiQ line and therefore the data exchange.

The DME20 can be used with SINAMICS firmware version 2.6 or higher.

 <b>CAUTION</b>
The cooling clearances of 50 mm above and below the component must be observed.

### Additional references

You can find further information on the DME20 in the SINAMICS S120 manual titled "Control Units and Additional System Components".

## 11.7 Ordering data

Table 11-13 Order data for system components

<b>System components</b>	<b>Order numbers</b>
NCU 710.2 with PLC 317-2DP	6FC5371-0AA10-0AA1
NCU 720.2 with PLC 317-2DP	6FC5372-0AA00-0AA2
NCU 720.2 PN with PLC 319-3PN/DP	6FC5372-0AA01-0AA2
NCU 730.2 with PLC 317-2DP	6FC5373-0AA00-0AA2
NCU 730.2 PN with PLC 319-3PN/DP	6FC5373-0AA01-0AA2
Numeric Control Extension NX15 (High Extension)	6SL3040-0NB00-0AA0
Numeric Control Extension NX10 (High Extension)	6SL3040-0NC00-0AA0
Dual fan/battery module	6FC5348-0AA02-0AA0
COM01.2 RS232C(V.24) module for NCU 7x0.2	6FC5312-0FA01-0AA0
TS Adapter IE ISDN with integrated ISDN terminal adapter	6ES7972-0ED00-0XA0
TS Adapter IE Modem with integrated analog modem	6ES7972-0EM00-0XA0

Table 11-14 Ordering data for spare parts

<b>Spare parts</b>	<b>Order numbers</b>
Battery	6FC5247-0AA18-0AA0
Seal for segregated heat removal	6FC5348-0AA07-0AA0
Spacer	6FC5348-0AA06-0AA0
Front cover	6FC5348-0AA00-0AA0
Blanking plate	6SL3064-3BB00-0AA0
Cover for optional guide frame	6SL3064-3CB00-0AA0
Blanking cover (50 pcs.) for DRIVE-CLiQ interfaces	6SL3066-4CA00-0AA0
PROFIBUS/MPI plug connector with terminating resistor	6ES7972-0BB41-0XA0
CompactFlash Card 1 GB empty	6FC5313-5AG00-0AA0
CompactFlash Card 1 GB empty	6FC5313-5AG00-0AA1
CompactFlash Card 8 GB empty	6FC5313-6AG00-0AA0
CNC user memory expansion 2 MB	6FC5800-0AD00-0YB0
PLC user memory expansion 128 KB	6FC5800-0AD10-0YB0

# Appendix

## A.1 Abbreviations

AWG	American Wire Gauge
BERO	Proximity limit switch
B-MPI	Handheld unit with MPI connection
CAT5	Quality class (category) for shielded twisted-pair cables. Class 5 states that these cables have a particularly low damping factor, making them suitable for 100 Mbit/s-FastEthernet networks.
CBA	Component Based Automation: Component Based Automation
CNC	Computerized Numerical Control Computerized numerical control
CPU	Central Processing Unit Central processing unit
CRC	Cyclic redundancy check: Checksummenprüfung
DIN	Deutsche Industrie Norm (German Industry Standard)
DIP	Dual In-Line Package: Dual in-line arrangement
DP	Distributed I/O
DRAM	Dynamic Random Access Memory
DRIVE-CLiQ	Drive Component Link with IQ
EGB	Electrostatic Sensitive Devices
EMC	Electromagnetic compatibility
EN	European standard
ESD	Electrostatic discharge: elektrostatische Entladung
EUI	User Interface
Full duplex	An Ethernet/PROFINET port can simultaneously transmit and receive data.
HMI	Human Machine Interface: SINUMERIK operator interface for operating, programming and simulation
HSC	High-Speed Cutting
HT	Handheld Terminal
I/O bus	I/O bus
LEDs	Light-emitting diode light-emitting-diode display
MAC	Media Access Control
MCP	Machine Control Panel
MLFB	Machine-Readable Product Code
MPI	Multi-Point Interface Multi-point interface
MPP	Machine Push Button Panel
NCK	Numerical Control Kernel: NC kernel with block preparation, traversing range, etc.
NCU	Numerical Control Unit: NCK hardware unit
NX	Numerical eXtension (axis extension module)
OLP	Optical Link Plug: Fiber-optic bus connector
OP	Operator Panel : Operator panel front
OPI	Operator Panel Interface

PCU	PC Unit: Computer unit
PG	Programming device
PLC	Programmable Logic Control: Programmable logic control (component of the CNC controller)
PN	PROFINET
RAM	Random Access Memory: Program memory which can be read and written into
SIM	Single Inline Module
SRAM	Static RAM: Static memory (battery-backed)
TCU	Thin Client Unit (communication with operator panels)
TS	Teleservice
VDE	Association of Electrical Engineering, Electronics and Information Technology (Germany)

## A.2 Publication-specific information

### A.2.1 Feedback on the documentation

This document will be continuously improved with regard to its quality and ease of use. Please help us with this task by sending your comments and suggestions for improvement via e-mail or fax to:

E-mail: <mailto:docu.motioncontrol@siemens.com>

Fax: +49 9131 - 98 2176

Please use the fax form on the back of this page.

<b>To</b> SIEMENS AG I DT MC MS1 P.O. Box 3180  D-91050 Erlangen / Germany  Fax: +49 9131 - 98 2176 (Documentation)	<b>From</b>
	Name:
	Address of your company/department
	Street:
	Zip code:            City:
	Phone:                /
Fax:                    /	

Suggestions and/or corrections

A.2.2 Overview

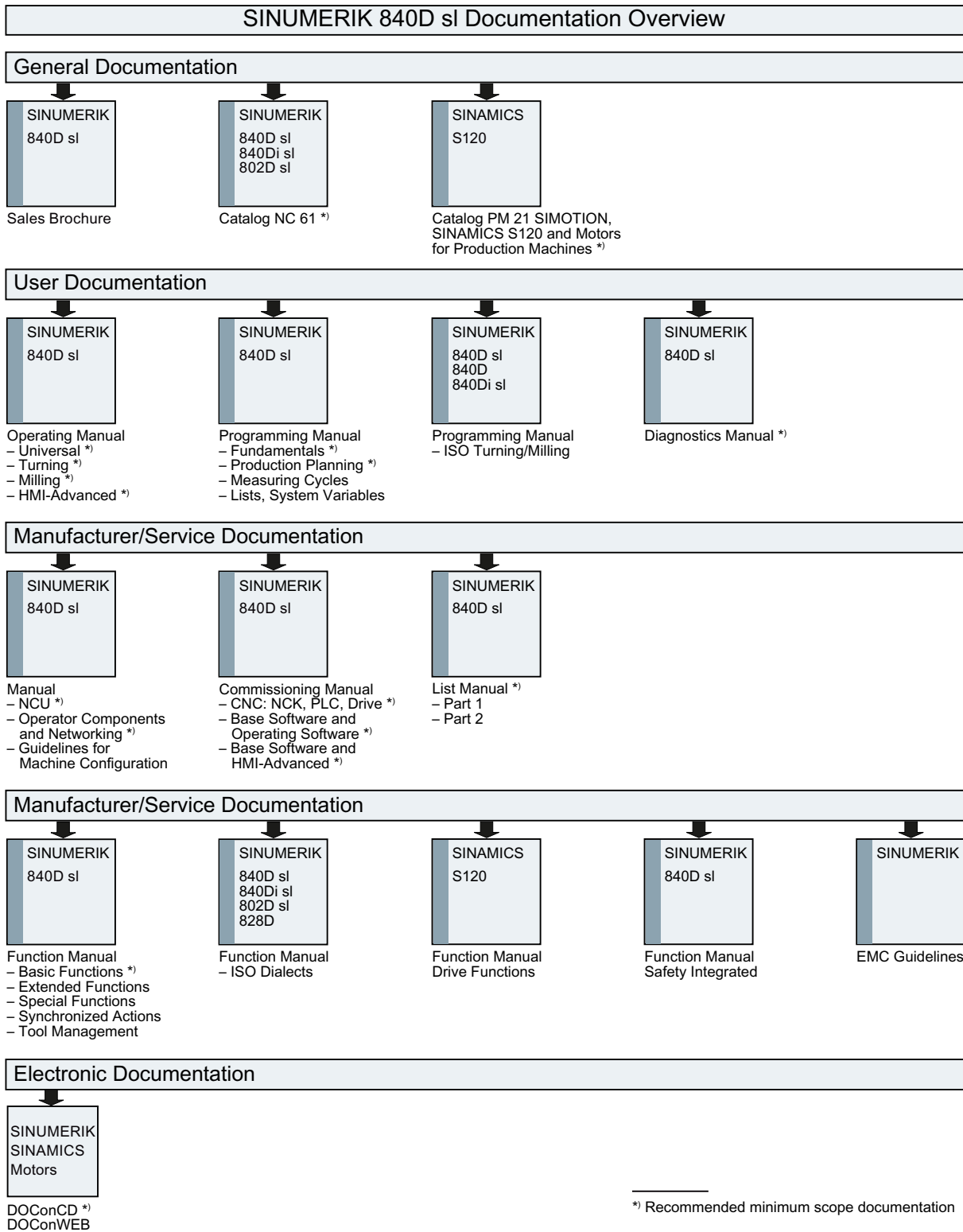



# Index

## A

- Active Line Module, 68
- Actuators, 61
- Air-conditioning
  - Storage and transport, 24, 26
- Ambient conditions, 23
- Axes, 17
- Axis expansion, 90, 99

## B

- Backup batteries, 25
- Battery, 89
  - Backup time, 88
- Bus connector, 75
  - MPI, 79
  - Setting the terminating resistor, 77

## C

- Cables
  - DRIVE-CLiQ, 67
- CBE30
  - Installing, 105
- Coding switches, 38
- Connection conditions, 23
- Cooling, 87
- Crossover cable, 69

## D

- DC supply, 65
- Designs, 54
- Diagnostics
  - Ethernet, 42
  - PROFINET, 46
  - System, 36
- Digital inputs/outputs
  - Assignment, 49
  - Connecting cables, 82
  - Technical data, 50
  - Wiring, 82
  - Wiring diagram, 81
- DMC20, 106

- DME20, 107
- DRIVE-CLiQ
  - Assignment, 41
  - Connectable components, 68
- Dual fan/battery module
  - Battery replacement, 89
  - Properties, 87

## E

- EMC Directives, 73
- Equipment
  - Open, 53
- Equipotential bonding, 21
- Ethernet
  - Cable specification, 69
- Ethernet ports
  - Pin assignment, 42

## F

- Front cover
  - Opening, 63
- Function-impairing dust, 26

## G

- Grounding connections, 21
- Grounding measures, 20

## H

- Hub Module DMC20, 106
- Hub Module DME20, 107

## I

- Interface
  - Digital inputs/outputs, 82
  - DRIVE-CLiQ, 41
  - Ethernet, 42, 104
  - PROFIBUS, 47
  - PROFINET, 45
  - X122/X132, 82
- Interfaces, 29
  - Power supply, 40

- L**
- LED displays
  - CBE30, 103
- LEDs
  - Ethernet, 42
  - PROFINET, 46
- License key, 35
- Long-term storage, 24
  
- M**
- MAC addresses, 44, 46
- Messages, 37
- Motor Module, 68
- Mounting
  - For segregated heat removal, 59
  - Side, 60
  - With spacers, 56
  - Without spacers, 56
- MPI bus
  - Bus connector, 79
  - Connection rules, 79
- MPI interface, 48
  
- N**
- NCK start-up switch, 38
- Noise immunity, 22
- NX10/15
  - Call sequence, 99
  - Mounting aids, 98
  
- O**
- Operator control and display elements, 33
- Operator panel, 16
  
- P**
- PLC mode selector switch, 38
- Power supply, 65
- Power supply connection
  - Power supply, 66
- Power supply interface
  - Assignment, 40
- PROFIBUS cable
  - Connecting, 77
  - Removing, 78
- PROFIBUS cables
  - Baud rate, 75
  - Cable length, 75
  - Properties, 74
  - Rules for cabling, 76
- PROFIBUS DP interfaces, 47
- PROFINET, 17
- PROFINET cables, 70
- PROFINET CBA, example configuration, 73
- PROFINET interfaces
  - Pin assignment, 45
  
- R**
- RESET button, 37
- RJ45 plug, 71
  
- S**
- Safe operation, 11
- Seal, 55
- Sensor Module, 68
- Sensors, 61
- Shield contact
  - Using, 83
- Shielded signal lines, 21
- Spacer, 56
- Standard IE cables, 70
- Stationary operation, 24
- Status display, 37
- Status messages, 37
- Subnet
  - Connection components, 76
  - Segment, 76
  - Terminating resistor, 76
  
- T**
- Teleservice, 69
- Terminating resistor, 76
- Test and diagnostic messages, 37
- Test sockets, 84
- TM15 Terminal Module, 106
- Transport, 24
- Twisted pair cable, 71
- Type plate, 32
  
- V**
- Ventilation, 87