



**BAD BOY
MOWERS**



MZ MODELS

ZERO-TURN MOWER OWNER'S OPERATOR SERVICE AND PARTS MANUAL

For additional information, please see us at
www.badboymowers.com



TABLE OF CONTENTS

Basic Information	Section 1	Page 4
Bad Boy Safety Guidelines.....	Section 2	Page 5
Operation	Section 3	Page 9
Maintenance.....	Section 4	Page 10
Storage and Transportation.....	Section 5	Page 10
Troubleshooting and FAQ	Section 6	Page 12
Controls.....	Section 7	Page 13
Moving In-operable Mower.....	Section 8	Page 14
Instrumentation	Section 9	Page 14
Mower Blade Maintenance.....	Section 10	Page 15
Equipment Lubrication.....	Section 11	Page 15
How To Choose the Right Blade		Page 16
Mowing Tips		Page 17
Service Section		Page 18
Parts Section.....		Page 42
Limited Warranty		Page 54



BAD BOY MOWERS

THIS MANUAL APPLIES TO THE FOLLOWING EQUIPMENT:

BAD BOY MZ SERIES

MZ 42" 5400 SERIES Kohler

MZ 42" KT725 Kohler

MZ Magnum 48" KT725 Kohler

MZ Magnum 54" KT740 Kohler

MZ Magnum 48" FR651V Kawasaki

MZ Magnum 54" FR651V Kawasaki

COMMONLY USED ITEMS AND PART NUMBERS

42" MZ Blade	Hi-Lift Fusion 038-4221-00	Gator Blade 038-4222-00	Wave Blade N/A
48" MZ Blade	Hi-Lift Fusion 038-4826-00	Gator Blade 038-4827-00	Wave Blade 038-4825-00
54" MZ Blade	Hi-Lift Fusion 038-0005-00	Gator Blade 038-0003-00	Wave Blade 038-5220-00
42" MZ Deck Belt	041-4022-00		
48" MZ Deck Belt	041-1470-00		
54" MZ Deck Belt	041-1560-00		
MZ Pump Belt	041-6400-00		
Oil Filter	Kohler 5400 Series 015-0077-04	Kohler Engine 063-5004-00	Kawasaki Engine 068-8017-00
Air Filter	Kohler 5400 Series 015-0077-05 015-0077-06 Pre-Cleaner Element	Kohler Engine 063-5002-00 063-5003-00 Pre-Cleaner Element	Kawasaki Engine 063-2097-00
Fuel Filter	Kohler Series 015-0077-07	Kohler Engine 063-5001-00	Kawasaki Engine 063-6000-00
Spark Plug	Kohler Series 015-0077-03	Kohler Engine 015-8000-00	Kawasaki Engine 015-8001-00
Motor Oil	10W-30 Motor Oil - Bad Boy Synthetic Blend Motor Oil Recommended. 085-6015-00		



SECTION 1: BASIC INFORMATION

Congratulations on the purchase of your new Bad Boy Mower! The purpose of this manual is to assist operators in maintaining and operating their machine. The information and instructions in this manual can help you attain years of performance from your new Bad Boy. Also, check out our website to learn more about the Bad Boy family.

- 1.1 All Bad Boy engines use 10W-30 engine oil. For maximum protection, Bad Boy synthetic blend engine oil is recommended.
- 1.2 All Bad Boy Mowers use hi-temp multi-purpose grease. NLGI No. 2 for the grease fittings.
- 1.3 MZ models have 12 psi in both front and rear tires.
- 1.4 Most Briggs, Kohler, and Kawasaki engines hold approximately two (2) quarts of motor oil. Be careful not to over fill engine oil. Refer to engine's service manual.

WARRANTY REGISTRATION

The Warranty Registration form must be completed within 30 days to validate your warranty. As the new equipment owner, you are expected to see that the form is completed and forwarded to Bad Boy Inc. at time of delivery. Warranty is nontransferable. **Warranty registration should be completed by the selling dealership using the on-line registration site.**

MODEL/SERIAL NUMBER

Your MZ model serial numbers are found on the SIN plate underneath the seat. These numbers can assist you in the ordering of new parts when replacements become necessary.

PARTS/SERVICE

Bad Boy recommends using Bad Boy replacement parts on your mower. Replacement parts are available through your local Bad Boy Mowers Dealer. Remember to always provide the following information when ordering parts:

1. Correct part number
2. Correct serial number

All warranty repair and service must be handled through your authorized Bad Boy Mowers Dealer. To locate the nearest dealer, go to our website and click on Locate a Dealer.

EVAPORATIVE EMISSION CONTROL WARRANTY STATEMENT

Federal Evaporative Emission Control Warranty: Your Warranty Rights and Obligations

The Environmental Protection Agency (EPA), and Bad Boy Inc. are pleased to explain the evaporative emission control system's warranty on your 2020 equipment. New equipment that uses spark ignition engines for off-road use must meet stringent anti-smog standards. The evaporative emission control system on your equipment is designed, built, and equipped so it conforms at the time of sale to the ultimate purchaser with the requirements of 40 CFR 1060. The evaporative emission control system is free from defects in materials and workmanship that may keep it from meeting said requirements. Bad Boy Inc. must warrant the evaporative emission control system on your equipment for two years provided there has been no abuse, neglect, or improper maintenance. If an evaporative emission control system component does fail in a manner that would cause the equipment to no longer meet the requirements of 40 CFR 1060 within the first two years Bad Boy Inc. will replace the defective component. Your evaporative emission control system may include parts such as fuel tanks, fuel lines, carbon canisters, fuel caps, valves, vapor hoses, clamps, or connectors.



SECTION 2: MOWER SAFETY GUIDELINES

Never allow untrained people to operate this machine. It is the owner's responsibility to get training and see to it that anyone who has permission to use your machine receives the proper training. Do not mow around people. The factory discharge chute is designed to deflect debris downward, but it could be possible for debris to be thrown in a way that can cause damage to people or property. Seek additional training when possible to learn more about safety techniques and practices. **This cutting machine is capable of amputating hands and feet and throwing objects. Failure to observe the following safety instructions could result in serious injury or death.**

GENERAL OPERATION

- 2.1 Read, understand, and follow all instructions on the machine and in the manual before starting.
- 2.2 Do not put hands or feet near rotating parts or under the machine. Keep clear of the discharge opening at all times.
- 2.3 Always remain seated while operating the machine. If the machine is equipped with Roll Over Protection (ROPs), always buckle your seat belt.
- 2.4 Only allow responsible adults who are familiar with the instructions to operate this machine.
- 2.5 Clear the area of objects such as rocks, wire, toys etc., which could be thrown by the blades.
- 2.6 Always maintain a safe distance from people and pets just prior to and during operation. Stop the machine if anyone enters the area.
- 2.7 Never carry passengers.
- 2.8 Do not mow in reverse unless absolutely necessary. Always look down and behind before and while backing.
- 2.9 Never direct discharged material toward anyone. Avoid discharging material against a wall or obstruction as material may ricochet back toward the operator. Stop the blades when crossing gravel surfaces.
- 2.10 Never operate the machine without the discharge chute, grass catcher, or other safety devices correctly in place and functioning properly.
- 2.11 Slow down before turning.
- 2.12 Always disengage blades, place steering controls in neutral, engage parking brake, and remove ignition key when leaving operators seat. Never leave a running machine unattended. Disengage blades when not mowing.
- 2.13 Shut off engine, allow all moving parts to come to a complete stop, and allow to cool before performing any of the following actions: cleaning or inspecting the machine for damage, removing the grass catcher, or unclogging the discharge guard.
- 2.14 Always operate machine in daylight or with adequate working lights.
- 2.15 Do not operate the machine while under the influence of alcohol or drugs.
- 2.16 Watch for traffic when operating near or crossing roadways.
- 2.17 Always wear eye protection when operating or servicing the machine.
- 2.18 Always wear ear protection, such as earplugs, while mowing.
- 2.19 Use extra care when loading or unloading the machine into a trailer or truck.
- 2.20 Be alert of surroundings. Watch for rocks, stumps, mounds, depressions, and low hanging limbs or objects that could be potentially hazardous while mowing.
- 2.21 Data indicates that operators 60 years of age and above are involved in a large percentage of riding mower related injuries. These operators should periodically evaluate their ability to operate the riding mower safely enough to protect themselves and others from serious injury.
- 2.22 Prevent fires by keeping engine and exhaust areas clear of grass clippings and other debris. Do not park or back mower over or immediately adjacent to flammable materials.



SETTING DECK HEIGHT

- 2.23 If your machine is equipped with an actuator motor, raise the deck using the raise /lower switch. Refer to section 7 (Controls). When deck is raised, set desired height with the deck height control dial, then lower deck with the raise / lower switch.
- 2.24 If your machine is equipped with a foot pedal, press foot pedal to raise deck, select your desired deck height with the deck height dial, then slowly release foot pedal.

SLOPE OPERATION

Slopes are a major factor related to loss of control and tip over accidents, which can result in severe injury or death. Operation on all slopes requires extra caution. If you cannot back up the slope, or you feel uneasy on it, do not mow it. **Avoid operating your mower on side hills of over 5 degrees, inclines of over 10 degrees, and declines of over 15 degrees.**

- 2.25 Mow up and down slopes, not across.
- 2.26 Watch for holes, ruts, bumps, rocks, or other hidden objects that tall grass can obscure. Uneven terrain could overturn the machine.
- 2.27 Choose a low ground speed when operating the machine on a slope.
- 2.28 Do not mow on wet grass, the tires may lose traction.
- 2.29 Do not attempt to coast down a slope in the neutral position.
- 2.30 Avoid starting, stopping, or turning on a slope. If the tires lose traction, disengage the blades and proceed slowly, straight down the slope.
- 2.31 Keep all movement on slopes slow and gradual. Sudden changes in speed or direction could cause the machine to roll over.
- 2.32 Use extra care while operating machine with grass catchers or other attachments: they can affect the stability of the machine. Do not use on steep slopes.
- 2.33 Do not try to stabilize the machine by putting your foot on the ground.
- 2.34 Do not mow near drop offs, ditches or embankments. The machine could suddenly roll over if a wheel goes over the edge or the edge caves in.
- 2.35 Be aware of what is located at the bottom of slopes. For example: rocks water, cliffs, and roadways.

CHILDREN

Tragic accidents can occur if the operator is not alert to the presence of children. Children are often attracted to the machine and the mowing activity. NEVER assume that children will remain where you last saw them.

- 2.36 Keep children out of the mowing area and in the watchful care of a responsible adult other than the operator.
- 2.37 Maintain Alertness and turn machine off if a child enters the area.
- 2.38 Before and while backing, look behind and down for small children.
- 2.39 Never carry children, even with blades shut off. They may fall off and be seriously injured or interfere with safe machine operation. Children who have been given rides in the past may suddenly appear in the mowing area for another ride and be run over or backed over by the machine.
- 2.40 Never allow children to operate the machine.
- 2.41 Never leave the key in the ignition, especially around children.
- 2.42 Use extreme care when approaching blind corners, shrubs, trees, or other objects that may block your view of a child



TOWING

MZ and MZ MAGNUM

Max pulling weight: 200lbs.

Max weight at 5°: 170lbs.

Max tongue weight: 42" and 48" = 40lbs, 54" = 45lbs.

- 2.43 Tow only with a machine that has a hitch specifically designed for towing. Do not attach towed equipment except at the hitch point.
- 2.44 Follow the manufacturer's recommendation for weight limits for towed equipment and towing on slopes.
- 2.45 Never allow children or others in or on towed equipment.
- 2.46 On slopes, the weight of the towed equipment may cause loss of traction and loss of control.
- 2.47 Travel slowly and allow extra distance to stop.

SERVICE

SAFE HANDLING OF GASOLINE

To avoid personal injury or property damage, use extreme care in handling gasoline. Gasoline is extremely flammable and the vapors are explosive.

- 2.48 Extinguish all cigarettes, cigars, pipes, and all other sources of ignition.
- 2.49 Use only an approved gasoline container.
- 2.50 Never remove gas cap or add fuel with the engine running.
- 2.51 **Allow engine to cool before refueling.**
- 2.52 Never fuel the machine indoors.
- 2.53 Do not store machine near open flame or source of ignition, such as a water heater or furnace.
- 2.54 Remove gas powered equipment from the truck or trailer and refuel it on the ground. If this is not possible, then refuel such equipment with a portable container, rather than from a gasoline dispenser nozzle.
- 2.55 Never fill gasoline containers inside a vehicle or on a truck or trailer bed with a plastic liner. Always place containers on the ground away from your vehicle before filling.
- 2.56 Keep the nozzle in contact with the rim of the fuel tank or container opening at all times until the fueling is complete. Do not use a nozzle lock-open device.
- 2.57 If fuel is spilled on clothing, change clothing immediately.
- 2.58 Never overfill fuel tank. Replace gas cap and tighten securely. **Tank is full when level reaches bottom of fill tube.**

GENERAL SERVICE

- 2.59 Never operate machine in a closed area where dangerous carbon monoxide fumes can collect.
- 2.60 Keep all nuts and bolts tight to be sure the equipment is in safe working condition. Never operate a poorly maintained machine.
- 2.61 Do not touch hot areas of the machine.
- 2.62 Never interfere with the intended function of a safety device or reduce the protection provided by a safety device. Check their proper operation regularly.
- 2.63 Keep the entire machine free of grass, leaves, or other debris build up. Clean up oil or fuel spillage and remove any fuel-soaked debris. Failure to do so can affect the safety and functionality of the machine, as well as increase the danger of a fire due to contact with the hot surfaces of the machine.
- 2.64 Allow machine to cool before storing.
- 2.65 If you strike something with the mower, turn the mower and blades off, engage the parking brake, and inspect the machine for damage. Repair, if necessary, before resuming.



- 2.66 Never make any adjustments or repairs with the engine running.
- 2.67 Check grass catcher components and the discharge guard frequently and replace with manufacturer's recommended parts, when necessary.
- 2.68 Mower blades are sharp. Wrap the blade or wear gloves before servicing them.
- 2.69 Check parking brake operation frequently. Adjust and service as required.
- 2.70 Maintain or replace safety and instruction labels, as necessary.
- 2.71 Do not attempt to mount a tire without the proper equipment and experience to perform the job.
- 2.72 Always maintain the correct tire pressure. Do not inflate the tires above the recommended pressure. Never weld or heat a wheel and tire assembly. The heat can cause an increase in air pressure resulting in a tire explosion. Welding can structurally weaken or deform the wheel.
- 2.73 Park machine on level ground. Never allow untrained personnel to service machine. Understand service procedures before doing work.
- 2.74 Mower deck, frame, and engine compartment should remain free of debris to prevent premature part failures or fire hazards.

SAFETY INTERLOCK SYSTEM

Your Bad Boy mower is equipped with a safety interlock system. This system is designed to prevent serious injury or death to the operator and other people or property damage. The system consists of an operator presence switch in the seat, the parking brake, drive lever neutral position, the mower blade engagement switch, and the ignition switch. These interlocks are vitally important and must be tested frequently. Following are instructions to test these very important safety precautions. **Note: the operator must be seated properly on the machine during these tests and the engine should have been previously allowed to warm to operating temperature.**

- 2.75 With the parking brake engaged, bring lever arms to their inward position. Attempt to start the machine with the blade actuator in off position. The engine should not start.
- 2.76 On a level surface, disengage the parking brake and place lever arms to their outward position. Then, attempt to start the machine with the blade actuator in off position. The engine should not start.
- 2.77 Engage parking brake and leave lever arms in outward position. Put blade actuator in the on position, then attempt to start the machine. The engine should not start.
- 2.78 Next, start the engine as stated in the Mower Operation Section. Disengage parking brake. Very slowly begin to rise from the seat. The engine should stop.

If any of these tests fail to produce the results indicated and the problem cannot be identified, contact your Bad Boy Mower dealer or the support contacts in the back of this manual.

ROLL OVER PROTECTION STRUCTURES (ROPS)

This machine is not equipped with ROPS from the factory. If ROPS are added as an option, it is vital that the rules below are adhered to. ROPS, when used correctly, dramatically decrease the fatality rate in roll-over instances.

- 2.79 Periodically ensure the bolts that attach the ROPS to the machine are securely fastened.
- 2.80 Always operate the machine with the ROPS secured in the upright position.
- 2.81 If the surrounding environment (e.g. low-lying limbs, signage, etc.) makes it impossible to mow with the ROPS upright, lower the ROPS at the hinge point, mow the area, then immediately secure the ROPS upright.
- 2.82 Upright ROPS are taller than the operator's head. Be aware of this and your surrounding environment, as referenced above. The mower and operator may clear low-lying items, but the ROPS may not.
- 2.83 Always wear the provided seat belt when ROPS are utilized. Failure to use the seat belt severely handicaps the safety benefits of the ROPS.
- 2.84 In the event of a roll-over, replace the ROPS before resuming use of the machine.



SECTION 3: MOWER OPERATION

Never operate the machine with faulty equipment. Always be alert of sudden changes in landscape, as the mower will react differently on slopes or embankments than it will on flat surfaces. Never operate the mower with the discharge chute open. Do not cross terrain, other than grass, with blades turning. This could cause damage to property or bystanders.

- 3.1 Place parking brake in up position.
- 3.2 Drive arms must be in the "open" position. While sitting on the machine, each arm is positioned away from the operator, to the right and left. Drive arms will lock into place and must be in this position to start machine.
- 3.3 Put PTO switch in the OFF position.
- 3.4 If your machine has been equipped with a ROPS (Roll Over Protection System) then you must fasten seatbelt.
- 3.5 If machine has not been started recently, engage the choke.
- 3.6 Make sure nothing is under or around machine.
- 3.7 Place key in ignition and turn.
- 3.8 Once machine is started, disengage the choke.
- 3.9 Increase RPM by sliding the throttle to fast position, toward the rabbit.
- 3.10 Owners must become familiar with the controls before operating a zero-turn radius vehicle.
- 3.11 Start slowly and build your skill level. Have ample practice before using the machine at full capabilities.
- 3.12 Be comfortable with machine before engaging blades. Know what each component controls before using machine.
- 3.13 Your mower will perform differently on an incline /decline. Be cautious, slow down, and do not make any sudden jerking movements with control arms. The machine could lose traction on a decline or tip backwards on an incline.
- 3.14 Once you become comfortable with your Bad Boy Mower you will notice your overall mowing time will decrease.
- 3.15 Always engage PTO at full throttle.
- 3.16 Start engine with throttle position between half and full throttle.

*Avoid operating your mower on side hills of over 5 degrees,
inclines of over 10 degrees,
and declines of over 15 degrees.*



BAD BOY MOWERS

SECTION 4: MOWER MAINTENANCE

Maintenance	Interval					Section
	Daily	First 8 Hours	Every 50 Hours or Annually*	Every 100 Hours or Annually*	Every 250 Hours	
Check and add engine oil	●					Section 3
Check all belts for proper alignment	●					Section 2 (Pump) 6 (Deck)
Check tire pressure and wheel lug nuts	●					Section 5
Check battery terminal connections	●					Section 4
Check condition of blades	●					Section 6
Check for fuel and oil leakage	●					Section 3
Check deck and engine compartment for debris and clean as necessary	●					
Check air filters	●					
Initial oil change		●				Section 3
Tighten nuts and screws			●			
Change engine oil and filter			●			Section 3
Initial change of hydraulic oil and filter			●			Section 1
Grease mower				●		Section 5
Replace air element and pre-cleaner♦				●		Section 3
Replace fuel filter♦				●		Section 3
Clean or replace spark plugs and set gap				●		Section 3
Change hydraulic oil and filter					●	Section 1
Clean combustion chamber ^{Dealer}					●	
Check and adjust valve clearance ^{Dealer}					●	
Clean and lap valve seating surface ^{Dealer}					●	

*Maintenance by hour or annually whichever comes first

♦Check air and fuel filter more often in dusty conditions

^{Dealer} Get maintenance performed at a registered dealership

SECTION 5: MOWER STORAGE & TRANSPORTATION

- 5.1 Keep machine from collecting debris by storing in a covered area while not in use.
- 5.2 Fuel can harm your machine if left for more than 30 days without changing, especially if the fuel contains ethanol. Never use fuel with more than 10% ethanol by volume. E-15 is not permitted.
- 5.3 Disconnect the negative battery cable when machine will be stored for more than 30 days.
- 5.4 Always secure machine properly when transporting machine.
- 5.5 Do not load machine on trailer with blades engaged.
- 5.6 Do not use ramps to load the machine.
- 5.7 Make sure Parking Brake is in "up" position.
- 5.8 In wet conditions tires may spin while loading / unloading. If necessary, wait for dry conditions before loading/unloading.
- 5.9 Make sure mode of transportation is suitable to bear the weight of mower.
- 5.10 Deck height should be set at maximum before attempting to load.
- 5.11 Secure mower with at least two straps capable of securing weight of mower.
- 5.12 Always ensure mower engine and exhaust has cooled prior to parking inside building.



SECTION 6: TROUBLESHOOTING

6.1 **Q: *How do I prevent an uneven cutting pattern and increase the quality of cut?***

A: Check tire pressure, check blade sharpness (replace blades or sharpen at least once per year or when needed), make sure blades are tightened properly, check spring and belt tension, check the underside of the deck to ensure the mower deck is free of grass build-up and debris, make sure your machine is at full throttle, and vary your mowing pattern each time you cut your grass.

6.2 **Q: *What should I do if my mower won't start?***

A: Check battery charge and connection (grounds), check your fuel (make sure fuel is less than 30 days old and contains no water), make sure your spark plug is in good condition and spark plug wire is attached, make sure air filter is clean (a dirty filter makes it more difficult for the engine to draw air), check the integrity of the 25-amp main fuse, and check for any bare wires and/or bad connections.

6.3 **Q: *What should I do if the blades won't engage?***

A: Make sure the safety switch is plugged in on the bottom of seat. Check the underside of the PTO engager to ensure the plug is secure at switch. Also check PTO fuse underneath operator console (10-amps)

6.4 **Q: *What type of fuel is recommended for my mower?***

A: We recommend that you use a name brand fuel to ensure quality. Use fuel with an octane rating near 87. Higher octane fuels offer no benefit. Only fuels with an ethanol content of 10% or less may be used. By law, E-15 fuel is not permitted. Usage of E-15 will result in premature engine failure.

6.5 **Q: *Do you offer touch-up paint for your mowers?***

A: Touch-up paint is available. Contact your local dealer for more information.

6.6 **Q: *How do I clean my mower?***

A: It is recommended that you use an air hose or blower to remove dust and debris from the mower, to ensure there is not a buildup of grass on the mower deck and engine compartment, which could become a fire hazard. If you must wash the mower, ensure you run the engine to operating temp to dry water and engage the blades to spin off any standing water on the pulleys. Avoid spraying water onto electrical components and bearings, to prevent premature failure of these parts.



SECTION 7: CONTROLS

- 7.1 **Ignition Switch:** Bad Boy mowers have a three-position ignition switch: off, run, and start. With key inserted, rotate it clockwise to START position and release key when engine starts. Switch will automatically return to the RUN position.
- 7.2 **Throttle Control:** A cable is connected to the engine throttle for controlling engine speed. Move lever forward to increase engine rpm, move lever backward to decrease engine rpm.
- 7.3 **Choke Control:** The choke control, located to the operator's left, is a 'push-pull' type. When the choke knob is pushed in, the choke is in the off (run) position. When the choke is pulled out it is in the on (start) position. **Do not operate the machine in the on (start) position.**
- 7.4 **Control Levers:** These levers control the mower's speed, direction, and neutral lock. These levers are used to steer, accelerate, decelerate and change direction.
- 7.5 **PTO Switch:** This switch engages the blades. Pull the switch up to engage the blades and push the switch down to disengage the blades.
- 7.6 **Deck Height Control:** The deck height dial is used to set the cut height of the deck.
- 7.7 **Parking Brake:** The parking brake is used to hold the mower in place.

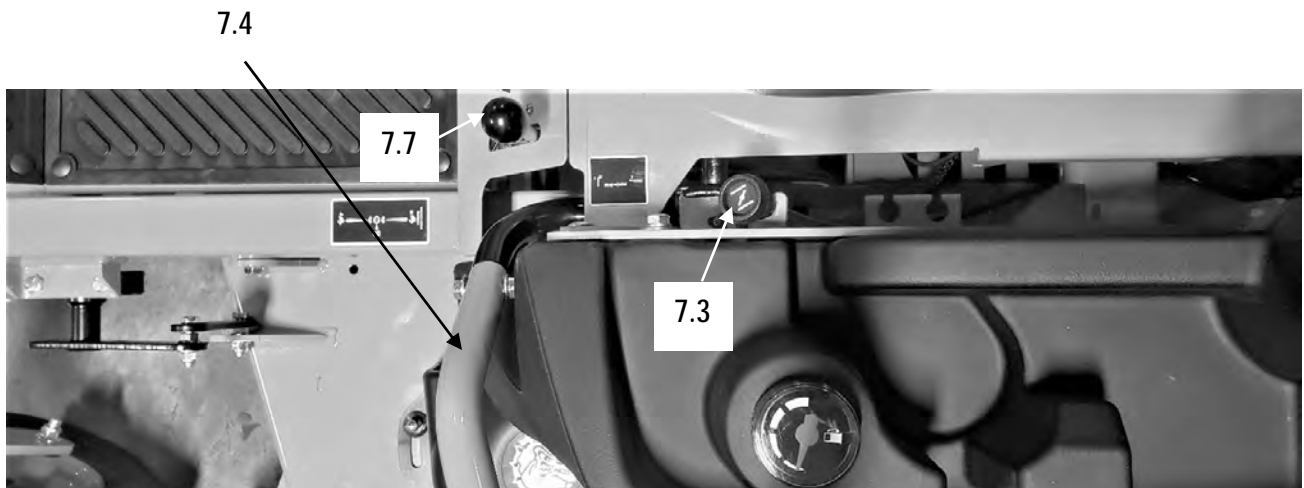
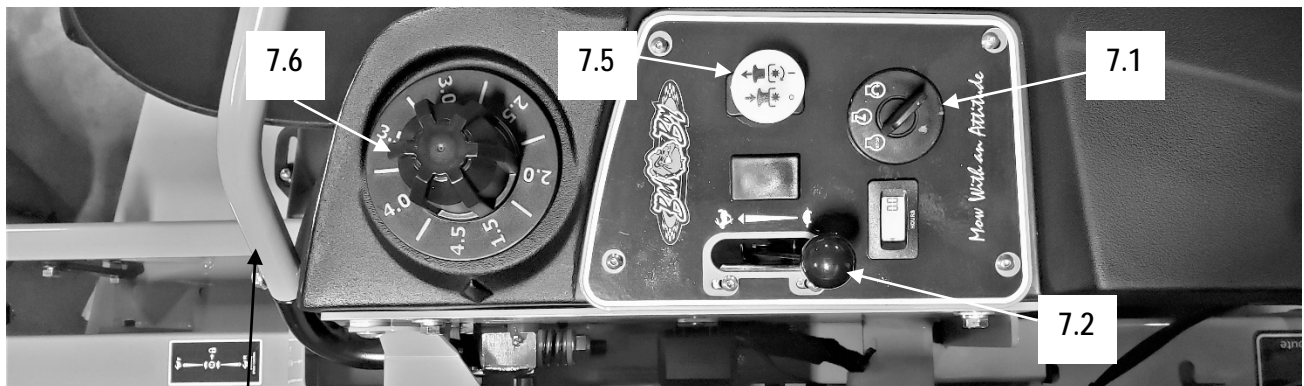



SECTION 8: MOVING INOPERABLE MOWER

- 8.1 Do not tow machine. Use a winch to load on a trailer for transporting.
- 8.2 MZ Models are equipped with two neutral engage/disengage arms, located at the rear of the mower protruding from the frame and under the muffler. By pulling the arms out, the mower can be put in a neutral position. Return the arms to the "forward position" for normal operation.

Your Bad Boy Mower Weighs: **MZ SERIES: 585-602 lbs.**
**** Weights fluctuate with the addition of accessories.*

- 8.3 As you can see by the weights of the machines, you shouldn't ever try to push or pull a Bad Boy Mower by hand. This could cause serious bodily injury.
- 8.4 Hopefully, you'll never need to use this section of the manual. However, if you do, use extreme caution when moving the machine!

SECTION 9: INSTRUMENTATION

- 9.1 **Electronic Hour Meter:** Registers Hour increments up to 9,999.9 total hours. This meter records the cumulative time the engine is running. (This is standard on the MZ Magnum and is an option on the MZ.)



SECTION 10: MOWER BLADE MAINTENANCE

- 10.1 Check mower blades after each use. This is essential for maintaining well-groomed turf. Keep the blades sharp. If a dull blade is used for cutting, the grass will tear rather than cut. This could damage the grass leaving a brown frayed top on the grass within a few hours. A dull blade will also require more power from the engine.
- 10.2 NEVER attempt to straighten a bent blade by heating. NEVER attempt to weld a cracked blade. The blades can break and cause serious injury or death.
- 10.3 NEVER work with blades while engine is running or PTO clutch is engaged.
- 10.4 ALWAYS place PTO clutch in DISENGAGE position while performing maintenance.
- 10.5 Use approved lifting equipment when working underneath your mower.
- 10.6 ALWAYS wear thick gloves when handling blades.
- 10.7 ALWAYS check for blade damage if mower strikes rock, branch, or other objects that could potentially damage the blade.

***(REMEMBER: NEVER CHECK BLADE WHILE ENGINE IS ON!
NEVER CHECK BLADES WHILE BLADES ARE ENGAGED!)***

SECTION 11: EQUIPMENT LUBRICATION

- 11.1 Park the machine on a level surface and disengage the blade control switch.
- 11.2 Move the motion control levers outward to the neutral position, engage parking brake, stop the engine, remove the key, and wait for all moving parts to stop before leaving the operating position.
- 11.3 Grease Type: NGLI grade #2 multi-purpose gun grease.
- 11.4 Clean the grease fittings with a cloth. Scrape any paint off the front face of the fitting(s).
- 11.5 Connect a grease gun to each fitting. Pump grease into the fitting until grease seepage is observed. Be mindful of over-pressurization. Do not force the grease into the component if excessive back pressure is felt as this can lead to reduced life of the component(s). Wipe up excess grease.
- 11.6 Refer to service manual section for grease fitting locations.



HOW TO CHOOSE THE RIGHT BLADE

Essentially there are only TWO basic styles of mowing blades used or approved for use on our current products:

1. The standard style of mowing blade is essentially designed for cutting grass and effectively discharging the clippings out from the deck to fall onto the lawn or to be captured in a grass collection system. Standard blades are also referred to as "2-in-1" (discharging & bagging) or "high-lift" blades (because they are designed to create a higher-lifting airflow).
2. Mulching blades generally have a more curved style surface and frequently include extra cutting surfaces along the blade edges. These blades may also come in a "+" design (which is actually two individual blades arranged in a perpendicular fashion to enhance mulching). The "+" blades are usually found on older style mowers; newer ones utilize blades with more advanced mulching technology. Mulching blades may also be referred to as "3-in-1" (mulching, discharging & bagging) or "all-purpose" blades.

Bear in mind that the re-circulating airflow design of 3/1 blades makes them less efficient at discharging grass clippings than a standard 2/1 blade. As with most all-purpose tools, there is some give and take as opposed to using a tool designed for a more specific purpose.

If you're experiencing less-than-desired cutting or discharging performance with a 3/1 blade, you may want to check into using a 2/1 blade. Conversely, if you're using a 2/1 blade and want to mulch clippings, you should see about the availability of mulching blades or a mulching kit. *

The type of blade installed on a new mower is a decision the retailer makes for each model of mower, based on the expected needs of most customers. If you're unsure of which blade is on a particular model, inspect the blade. Blades have part numbers stamped into them. Then compare these part numbers with the unit's Operator's Manual or Parts List.

It is true there are many other styles of blades available. But since we don't manufacture or recommend using these other aftermarket styles, we will leave them out of this discussion. Should you want more information on special application or aftermarket blades, you should contact the companies that make these products. NOTE: Customers using non-OEM blades do so at their own risk. The use of unapproved (non-OEM) blades may void any or all of the mower and engine factory warranties.

* **MULCHING KITS** – These generally consist of mulching blades and a mulching plug (which closes off the discharge opening to keep the clippings contained under the deck for re-cutting) plus any necessary hardware for installation. Please check with your parts distributor regarding the contents of a particular mulching kit.



MOWING TIPS:

- Mow header strips at the ends of the lawn and around flower beds first. Make them wide enough that you can turn the mower around in the already mown section. Then mow back and forth between these header strips overlapping each lap by about 1/8 the width of the mower's deck.
- Don't cut your grass too short, particular for cool season grasses. Higher heights usually provide for a deeper root system, looks better, and is less likely to have weeds invading, particularly crabgrass.
- Don't remove any more than one third of the grass leaf at any one cutting. If circumstances arise that a lawn gets too tall and you just have to lop off a bunch to get caught up, bite the bullet and break it down into several mowings to get caught up with 3 or so days between cuttings.
- NEVER SCALP YOUR LAWN.** Scalping severely damages the root system to such a degree that it may die.
- Avoid mowing when the grass is wet or when it's dark
- Avoid throwing grass clippings into the street and driveway where they can be washed into the sewer system. After mowing, clean up driveway and walkways.
- When mowing remove only a third with each cutting (except for the first mowing of the season when it's ok to remove more). You can safely leave clippings that will quickly decompose and add nutrients back into the soil. Contrary to popular opinion, grass clippings do not add to thatch buildup. Grass blades are made up of about 75% water.
- Mow your lawn in a different direction with each mowing, especially with lawns of shorter grass types. Altering the direction ensures a more even cut since grass blades will grow more erect and less likely to develop into a set pattern.
- Keep your mower's blade sharp, which means having it sharpened several times during the mowing season. Keep several blades around so you'll always have a sharp one on hand. Sharp blades cut the grass cleanly and help mulch clippings into small pieces which break down quickly.
- Don't forget to change your mower's oil at least once during the mowing season. For brand new mowers, change the oil after about 5 hours of operation during the initial break-in period.
- At the end of the mowing season use a fuel stabilizer in the remaining gasoline
- In the spring, don't use that old gas unless you properly used a fuel stabilizer, it can cause a number of problems. Better to use fresh gasoline to begin the new mowing season.
- Leaf blade A** demonstrates what a leaf blade should look like after mowing with a sharp blade.
- Leaf blade B** demonstrates a leaf blade that was injured by a dull mower blade.
- Leaf blade C** was cut by the mower but indicates that the mower blade is not sharp enough. The shredded white tissue protruding from the leaf blades C and D is the vascular tissue of the plant.
- Leaf blade D** has been mown for quite some time with a dull mower blade.

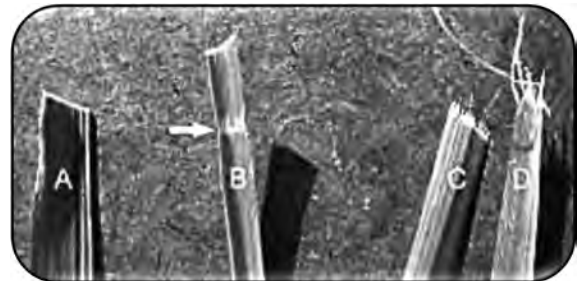

TO BAG OR TO MULCH?

Grass clippings do not contribute to thatch buildup or increase the chances of disease. If you mow your lawn at the right height, without removing any more than 1/3 of its total height, clippings will quickly breakdown without a trace. These clippings contribute additional nitrogen and other nutrients to the soil and supply it with additional organic materials. Clippings from a 1000 sq. ft. lawn can add as much as 1 - 2 pounds of nitrogen back into the soil. If you have a compost pile, then you may want to bag your clippings occasionally to add much needed green-matter to the compost pile. Make sure it is mixed thoroughly with brown matter to avoid a strong ammonia odor. **DO NOT COMPOST CLIPPINGS** after applying any weed control or weed-feed type product. Before adding clippings to the compost pile wait at least 3 mowings after these products have been applied.



BAD BOY MOWERS

SERVICE SECTION

SECTION 1: HYDROSTATIC SYSTEM

The hydrostatic system on MZ models is a sealed lifetime transaxle system, so no maintenance is required. Under the rear of the mower, you will find the two levers shown in the image. These bypass levers serve as a neutral for moving the mower while the engine is not running. Pull the levers out and lock them into place using the cotter pin to activate the bypass.

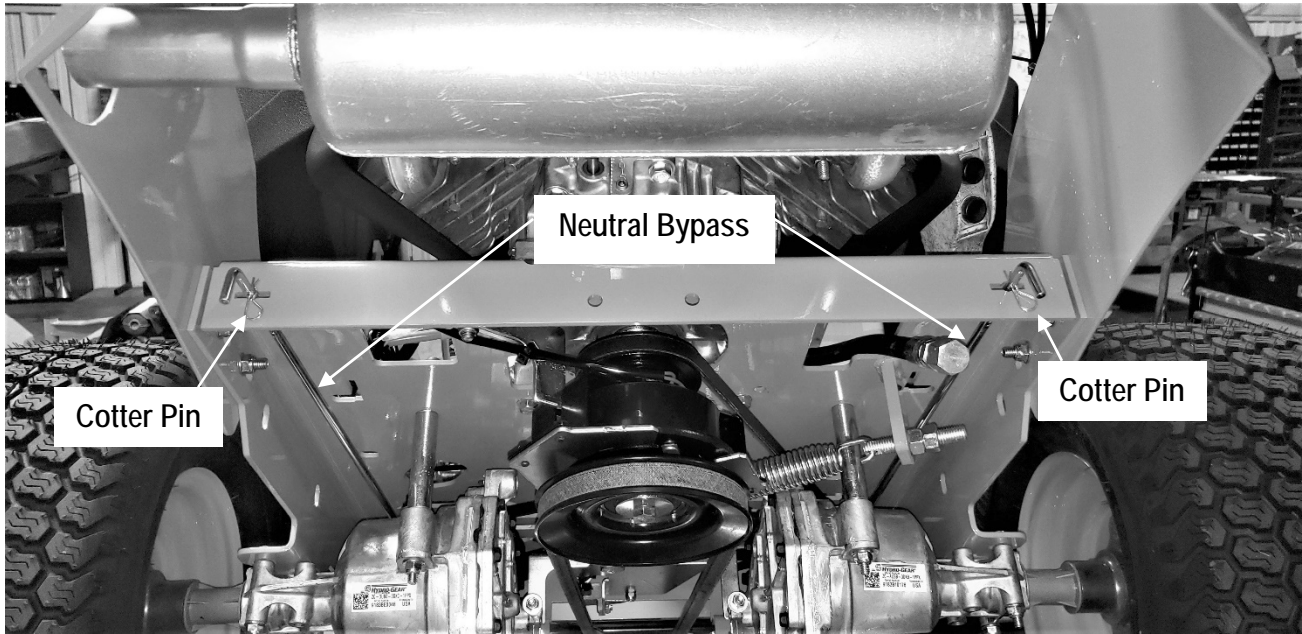

When adjusting the tracking on the mower, the length of the pushrods can be changed by screwing the swivel joint in or out on the ends of the rods. Shortening the overall length of the rod slows the pump down. Lengthening the rod will increase the speed of the pump.



Left Push Rod End



Right Push Rod End



SECTION 2: DRIVE BELT

Shown to the right is the pump belt tensioner. Using a 3/4" wrench, tightening the two jam nuts on the right side will increase the belt tension.

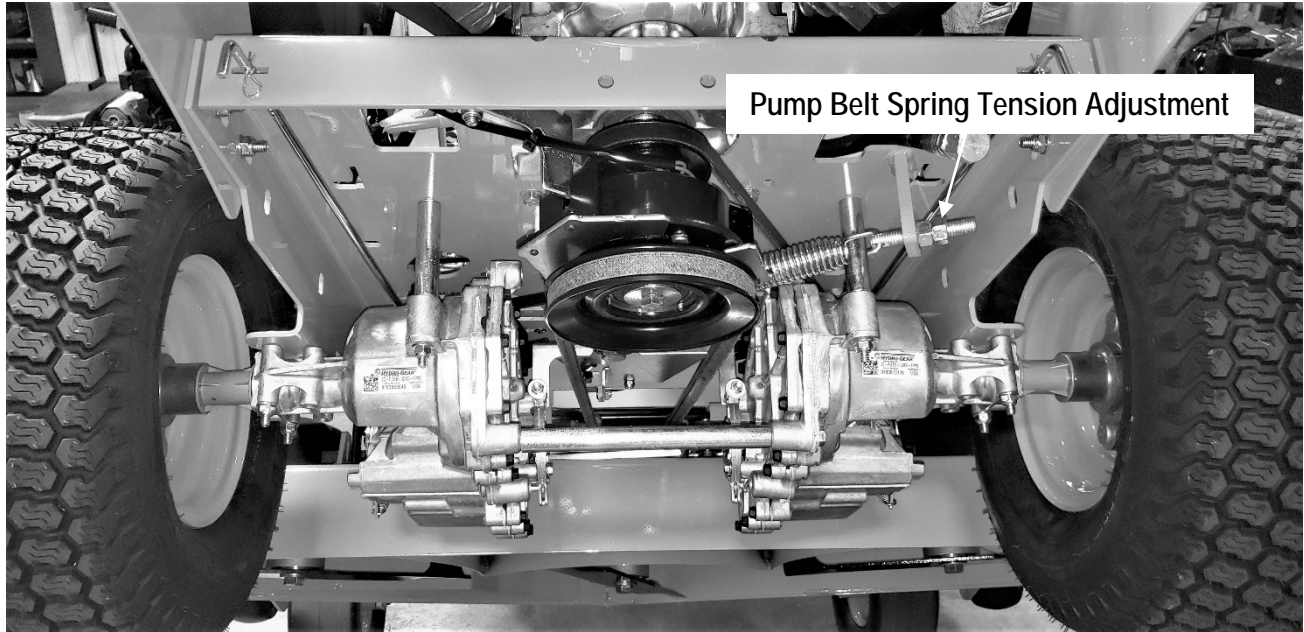

The tension should be adjusted so that there is between 60 to 65 lbs. of tension on the belt. This can be checked with a belt tension gauge (Part Number 041-9999-00) as shown to the right.

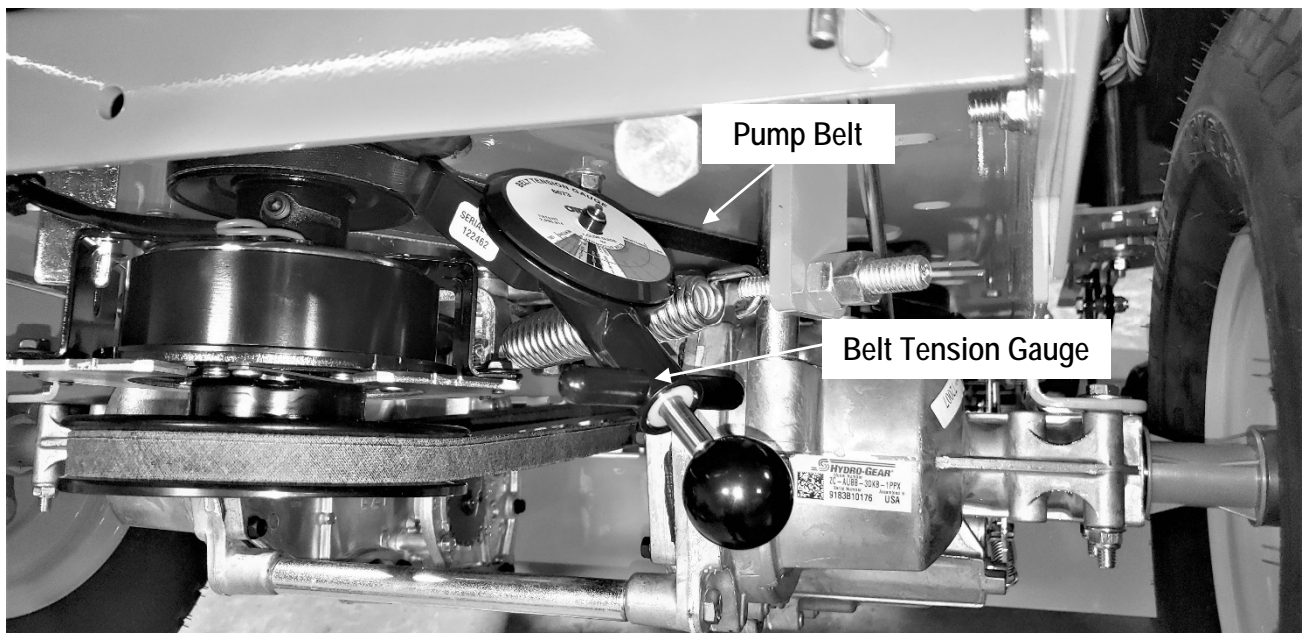



BAD BOY MOWERS

SECTION 3: ENGINE

ENGINE OIL

This machine has an oil drain hose installed on the engine to allow for easier oil changes. Bad Boy recommends that the oil and filter be changed after the initial 8 hrs. of use, and at intervals of 50 usage hours or yearly, whichever occurs first after that. The oil capacity is 2 quarts. Bad Boy 10W-30 synthetic blend engine oil is recommended for maximum protection.

CHANGING YOUR ENGINE OIL AND OIL FILTER

1. Remove oil dipstick and open oil drain. Allow oil to completely drain. (Make sure to have an oil pan ready to capture old oil and properly dispose old oil.)
2. Clean area around oil filter. Place a container under the oil filter to capture any oil and remove filter. Wipe off mounting surface and reinstall drain plug. Torque to 10 ft.*lbs.
3. Place new filter in shallow pan with open end up. Fill with new oil until oil reaches the bottom of the threads. Allow two minutes for oil to be absorbed by filter material.
4. Apply a thin film of clean oil to rubber gasket on new filter.
5. Refer to instruction on oil filter for proper installation.
6. Fill crankcase with approximately 2 quarts of new oil. Level should reach top of indicator on dipstick.
7. Reinstall oil filter dipstick and tighten securely.
8. Start engine; check for oil leaks. Stop Engine; correct oil leaks. Recheck oil level.
9. Dispose of used oil and filter in accordance with local ordinances.

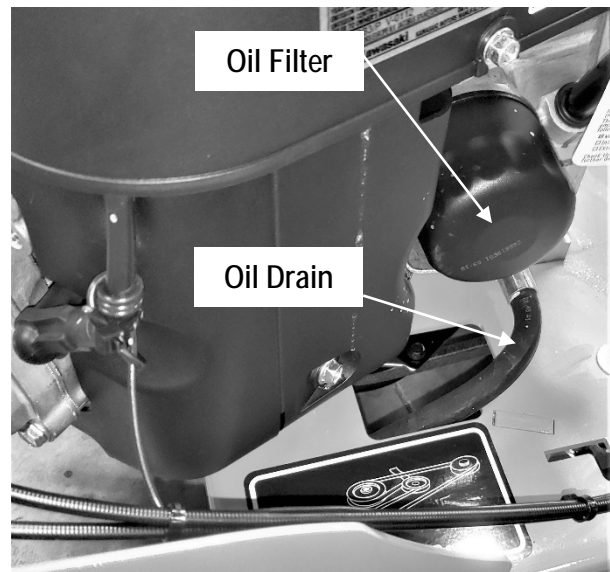
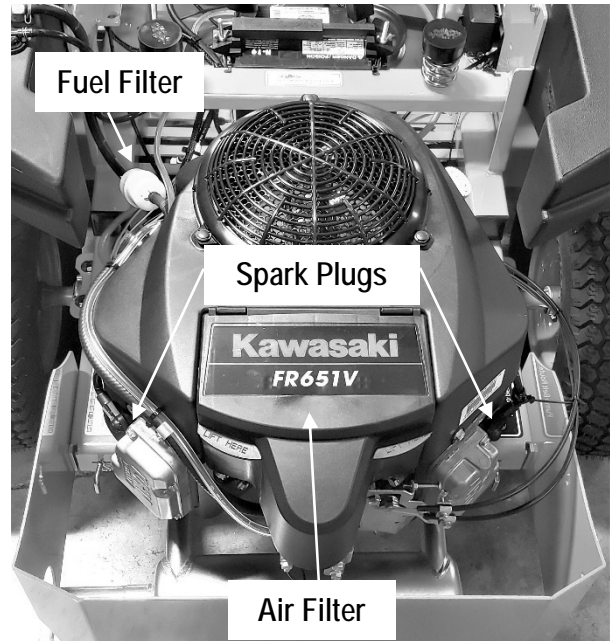



FUEL FILTER

The fuel filter is located in the fuel line. Replace the filter yearly. Prior to the removal of the old filter, note the direction of fuel flow as indicated on the filter. Have towels readily available in order to quickly remove any fuel leakage. Always use new hose clamps and ensure the security of the new filter by lightly pulling on each hose. Always perform maintenance outdoors or in a well-ventilated area. Do not smoke or allow any open flames in the vicinity of any maintenance activities.

CHANGING YOUR FUEL FILTER

1. Locate your fuel filter and mark the direction it is facing.
2. Clamp each side of the fuel filter to minimize any gas spills.
3. Remove the clips from each side of the fuel filter and remove the fuel filter.
4. Place the new fuel filter in the same direction as the old and place clips back into place.
5. Remove clamps.

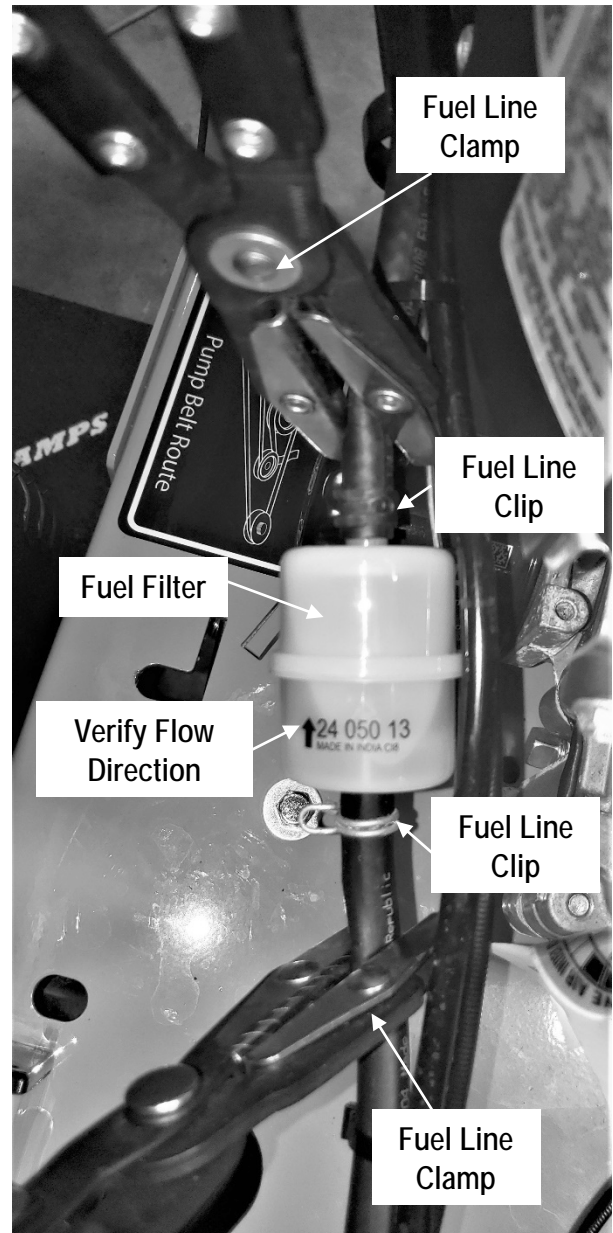



AIR CLEANER

The air cleaner is the engine's only defense against damaging foreign particles. It is very important that the air cleaner element is inspected prior to each use. Remove the element and tap its sides in order to remove debris. Do not blow the filter out using compressed air. Doing so will greatly reduce the air cleaner's effectiveness. Replace yearly; more often in dusty environments. Adhering to these practices will help prevent loss of power and premature engine failure.

CHANGING THE AIR CLEANER

1. Locate the air filter and remove the cover.
2. Remove the paper element and pre-cleaner (if applicable).
3. Replace or wash pre-cleaner in warm water with detergent. Rinse and allow to air dry (if applicable).
4. Lightly oil pre-cleaner with new engine oil; squeeze out excess oil (if applicable).
5. Replace paper element and place pre-cleaner onto new paper element.
6. Install paper element onto engine and reinstall air filter cover.

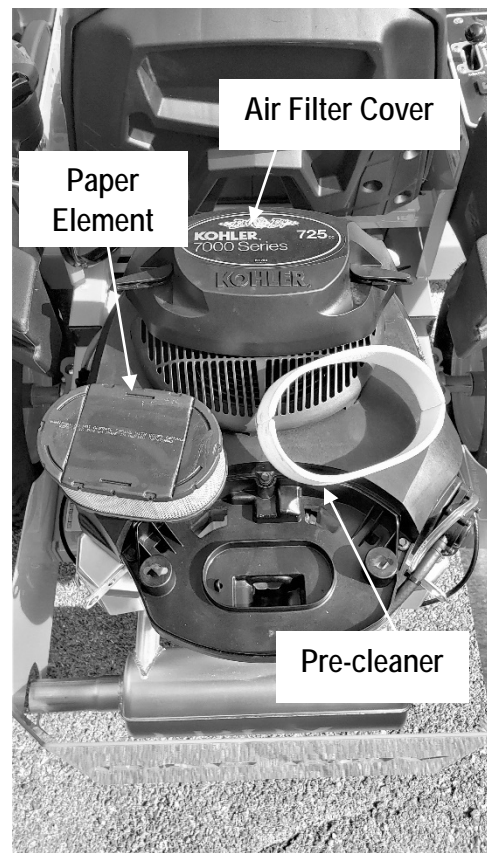
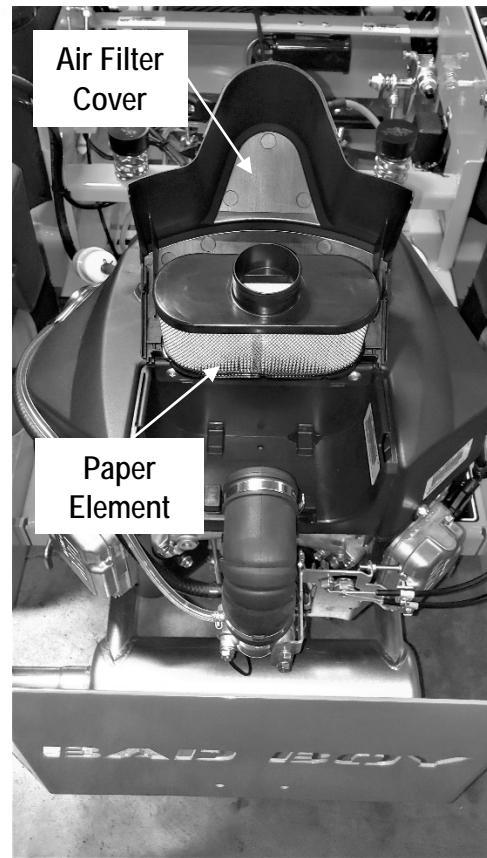



SPARK PLUG

CHANGING THE SPARK PLUGS AND CHECKING THE SPARK PLUG GAP

1. In order to access the spark plugs it is recommended to remove the rear engine cover. This can be accomplished by removing the four carriage bolts using a 1/2" ratcheting wrench.
2. Remove the wire on the spark plug and use an appropriate socket to remove the spark plug.
3. Check the gap on the spark plug to verify that it is 0.03" by using a feeler gauge.
4. If the spark plug is worn, overheated, wet or carbon fouled replace the spark plug.
5. Install the plug into cylinder head and torque to engine manufacture specifications. Be careful not to overtighten the spark plug.

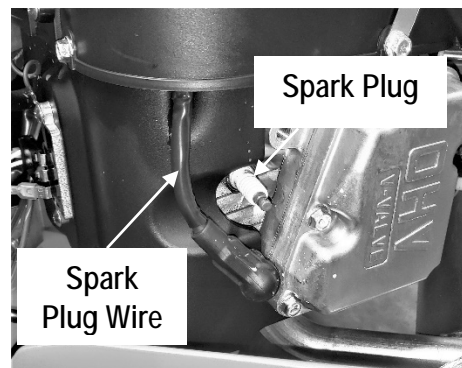
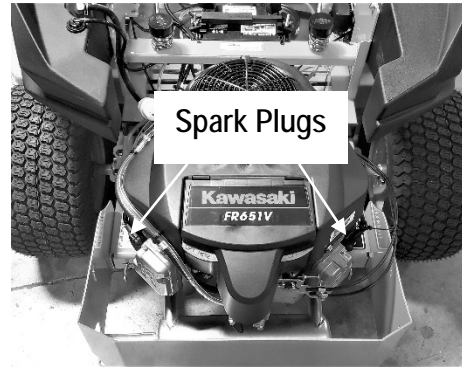
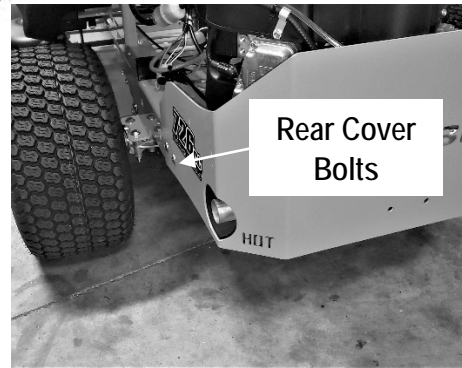

Spark Plug Component and Details

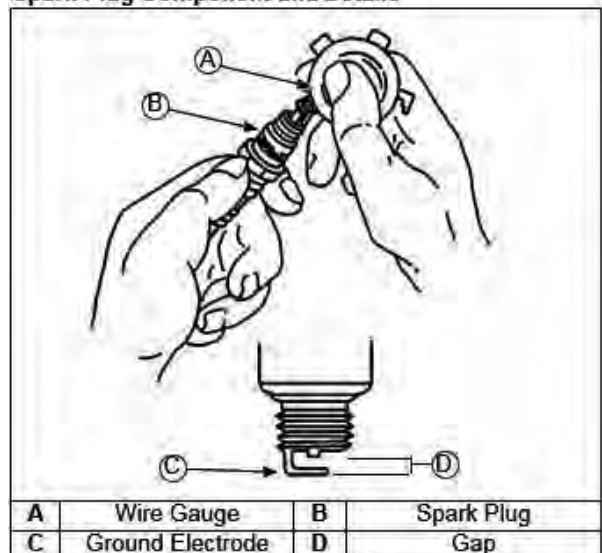



BAD BOY MOWERS

SECTION 4: ELECTRICAL SYSTEM

This mower is equipped with three protective fuses: a 25-amp main fuse (pictured to the right), a 10-amp clutch fuse (blade engagement) and a 15-amp linear actuator fuse (optional deck lift). The main fuse is located on the left side of the unit; by the starter solenoid. The clutch fuse is located just underneath the control panel along with the linear actuator fuse (if equipped).

A blown fuse usually indicates a problem within the electrical system or an electrical component. Never replace a fuse with one of a higher amperage rating or "by pass" a fuse in any way. Doing so creates a significant fire hazard and can cause severe damage to the mower's electrical components. If a fuse is repeatedly blowing, contact your Bad Boy dealer.

In order to access the clutch fuse, you will need to take off the control panel by removing four socket head screws using a 1/8" hex bit. This can be seen in the images on the right. Once you remove the screws remove the control panel and you can access the clutch fuse.

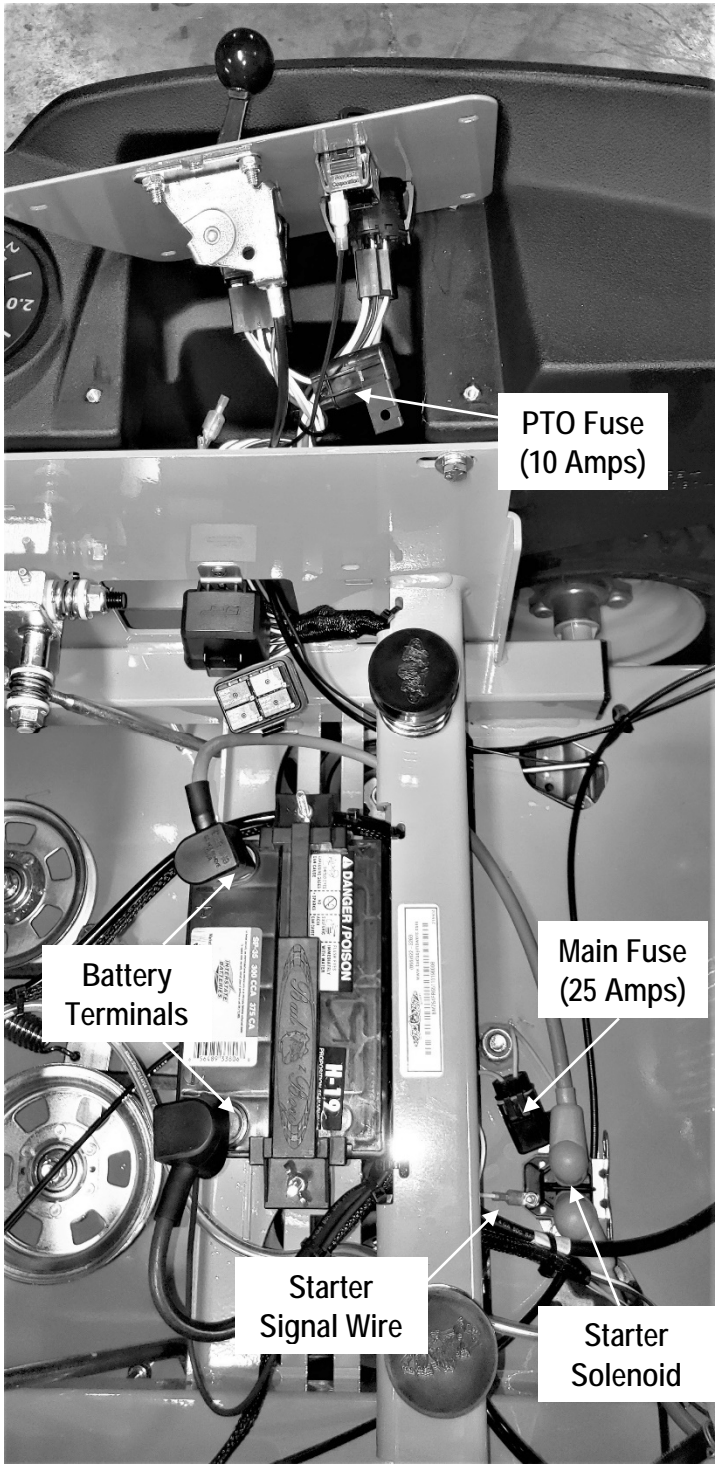



ELECTRICAL SYSTEM *(CONTINUED)*

On most models, the red wire coming out of the engine is the charging wire from the alternator. Check for 13.6 - 14.2 volts dc at this wire with engine at full throttle.

If you are having issues starting your mower ensure the signal wire is connected to your starter solenoid.

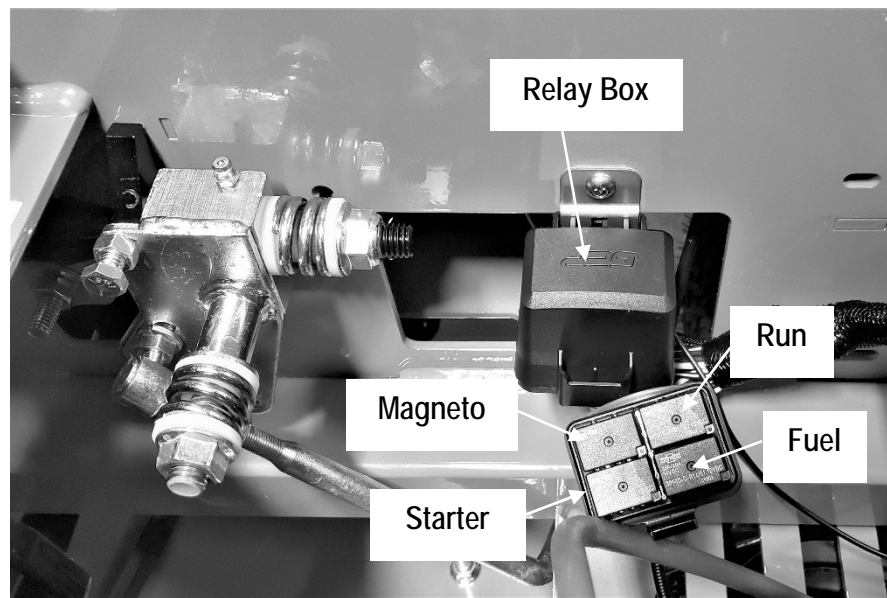

Check the condition and connection of the relays located under the seat on the right side of the frame. Ensure that they are clean and connected. Make sure that wire terminal ends have not been pushed out of the relay block.

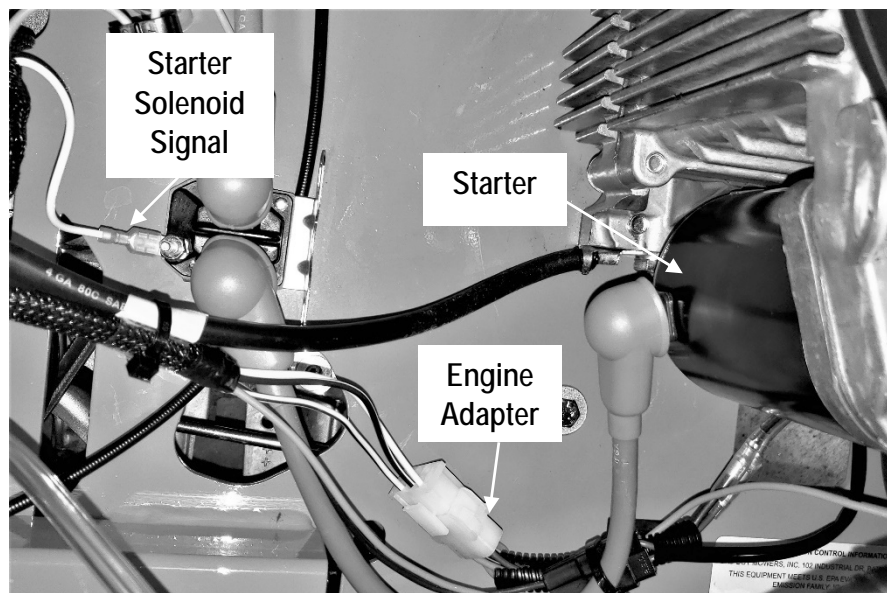



BAD BOY MOWERS

ELECTRICAL SYSTEM (CONTINUED)

WIRING DIAGRAM (For a larger version of the below diagram please visit badboymowers.com and click the parts manuals section)

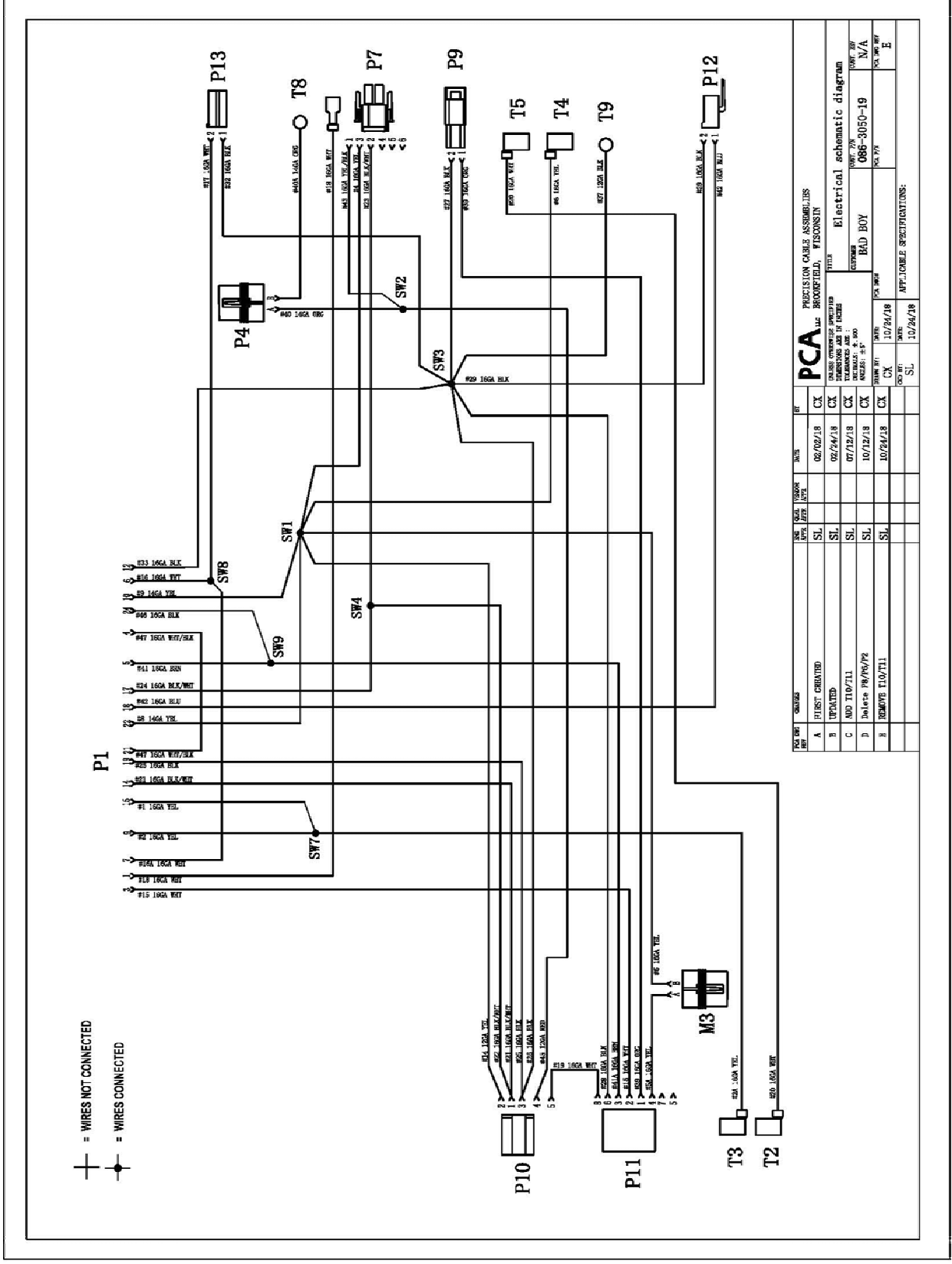

REV	DESCRIPTION	DATE	BY	DATE	BY
A	FIRST CREATED	SL		02/02/18	CX
B	UPDATED	SL		02/24/18	CX
C	ADD T10/T11	SL		07/12/18	CX
D	DELETE P10/P12	SL		10/12/18	CX
E	REMOVE T10/T11	SL		10/24/18	CX

PCA PRECISION CABLE ASSEMBLIES
 10000 BRONFIELD, WISCONSIN

TITLE: Electrical schematic diagram
 DRAWN BY: N/A
 CHECKED BY: N/A
 PART NO: 086-3050-19
 REV: N/A
 DATE: 10/24/18
 APPROVE: SL

APPLICABLE SPECIFICATIONS:
 NONE



SECTION 5: FRAME

The front fork nuts require a torque of 40ft.-lbs. While applying this torque, turn the fork itself to ensure no damage is done to the bearing. This operation is only necessary if a repair requires it. To access the recessed front fork nuts, remove the dust cap by prying gently using a flat-head screwdriver. Once cap is removed, a 1 7/16 in socket will be needed for top nut. You will need to secure the bottom nut with a 1 1/2" wrench. Once you have torqued the nuts to 40 ft.-lbs., reapply the dust cap by gently tapping around its edges. Do NOT hit center of cap.

Torque rear wheel lugs to 65-75ft. lbs. Re-torque at every oil change and check every morning.

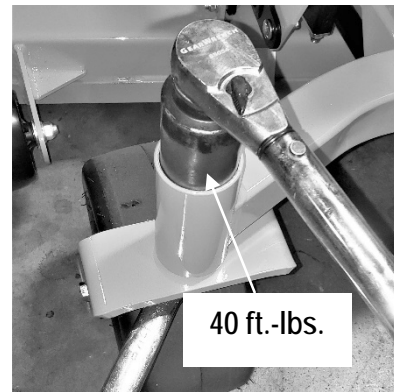

The pump belt tensioner is located under the engine and has a grease fitting at its pivot point. Grease at every engine oil change.

The deck belt tensioner is located at the rear of the deck and has a grease fitting on its pivot. Grease at every engine oil change.

The control arm blocks have grease fittings located on the top of each block. Grease one time a year.

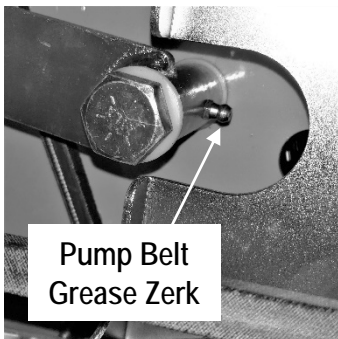



SECTION 6: CUTTING DECK

DECK BELT REMOVAL

1. Remove ignition key.
2. Raise the deck to its highest position.
3. Remove the right pulley cover.
4. While lifting up on the belt (as shown in the photograph), rotate the pulley until the belt is free of the pulley. Exercise caution while performing this step as fingers can easily become caught between the belt and pulley.

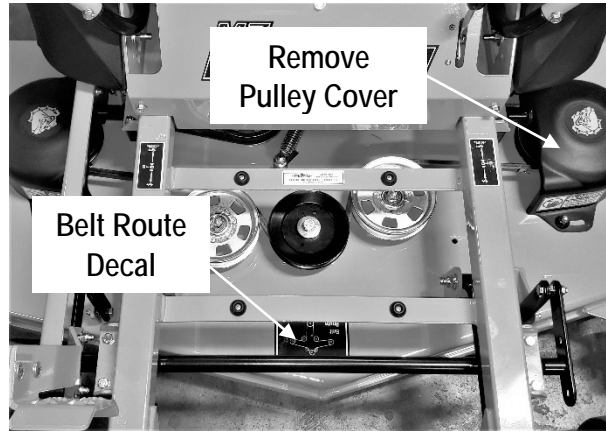

DECK BELT INSTALLATION

1. Remove ignition key.
2. Raise the deck to its highest position. If needed loosen the deck belt tensioner to its weakest installed position.
3. Take off both pulley covers and route the belt by following the belt route decal. (The easiest way to finish running the belt is routing the belt through the deck pulleys leaving it off the left deck pulley. Slip it onto the clutch then carefully slip it onto the left deck pulley.)
4. Verify that the belt is routed properly as improper routing can damage the spindles as well as the engine. Improper routing can also increase the potential of a personal injury hazard.
5. Check belt tension and adjust if needed.
6. Reinstall both pulley covers.

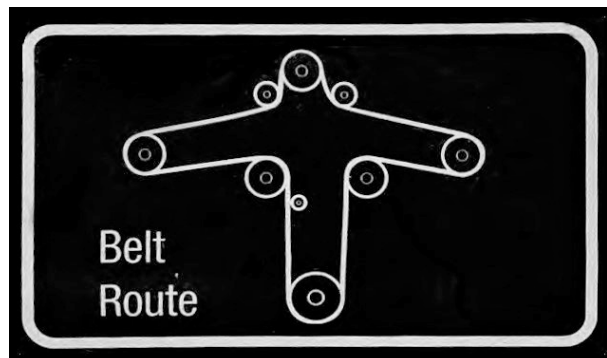
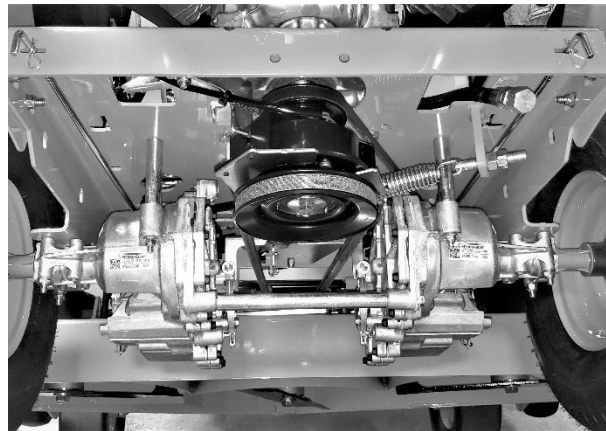



ADJUST DECK BELT TENSION

The deck spring tension is critical. If the tension is too high, premature failure of the deck belt and blade spindles can occur. If the tension is too low, the belt can "jump off" or slip on the pulleys. This results in reduced cut quality and early belt failure.

Spring tension adjustments can be made by sliding the bolt shown above forward or backward in the slot of the deck. Belt tension should be 60-65 lbs. with the deck at its lowest setting.

Use a belt tension gauge to ensure the proper tension. Your dealer or service center will have a belt tension gauge or you can buy one (Part Number 041-9999-00).

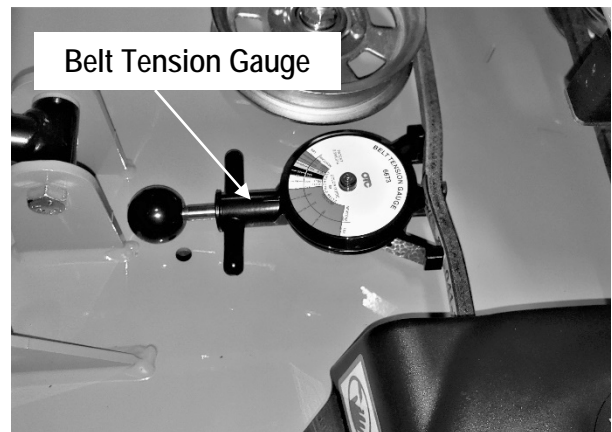
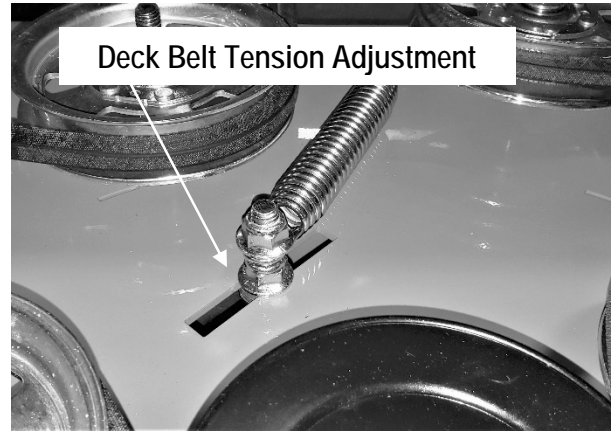

BLADE SHARPENING

The blade on the top (see photo) was utilized long after replacement was required. In addition to a decline in cut quality, failure to replace a worn or damaged blade creates a major safety hazard. Bad Boy recommends that blade sharpening be performed by a professional.

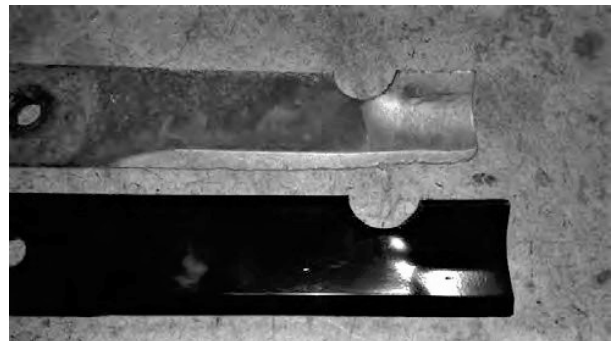



LEVELING THE DECK

Before leveling the deck, please verify linkage bar is secured properly as described in the picture to the right.

1. Start on a flat, level surface and set the air pressure in all four tires to 12 psi. Measure the deck at all four corners. The deck should be level from left to right but should be pitched downward front to back. The deck pitch is achieved by measuring from the cutting edge of the blade to the ground. Bad Boy recommends having a $\frac{1}{4}$ " pitch down in the front measured from the cutting edge of the blade. Adjustments can be made by adjusting the deck hangers in their slots.
2. Using a pair of approximately 3 ft. long 2x4's, stand the boards on edge and slide them under the deck from front to back as shown. Making sure the deck wheels and blade bolts do not rest on the 2x4's, and that the front and back edge of the deck rest on the 2x4's.
3. Lower the deck down onto the 2x4's using either the deck lift pedal or the electric actuator, whichever your mower is equipped with. The deck should now be approximately 3.5" off the ground. to achieve the proper $\frac{1}{4}$ " pitch down in the front it may be necessary to use some $\frac{1}{4}$ " spacers under the rear of the deck as shown.
4. Using a pair of $\frac{9}{16}$ " wrenches, loosen all deck hanger bolts on the top of the deck. These are the lower bolts in the slots of the deck as shown. Do not loosen the upper bolts that attach the deck hangers to the actuator lift bars.
5. The deck is now loose from the frame and movement of the lift pedal or electric actuator should only move the hanger bolts up and down in the deck slots. At this point a different deck height may be chosen on the cutting height dial. choosing a lower number will raise the decks cutting height. Choosing a higher number will decrease the decks overall cutting height. Remember, you should be approximately in the 3.5" range on your selection.
6. After setting the deck dial to the desired position, tighten all deck hanger bolts in their slots starting from the rear of the deck then moving to the front. Lift the deck to the highest position. measure all four corners of the deck again to ensure that no further adjustments are necessary.
7. Recheck belt tension before mowing.

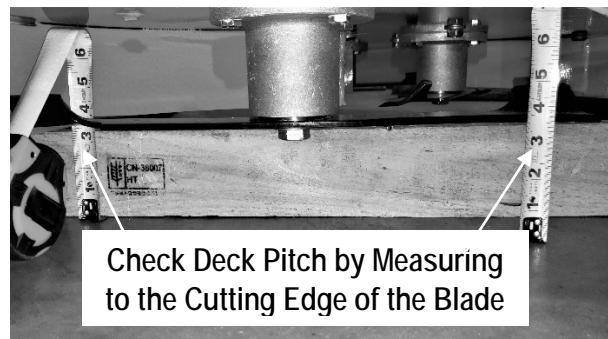
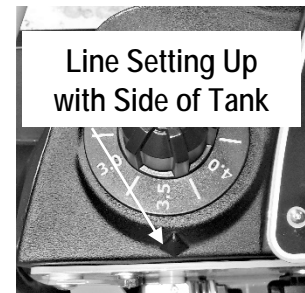
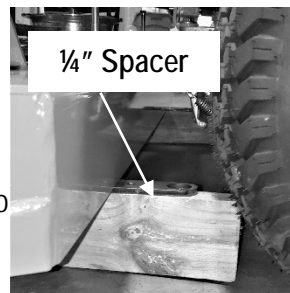
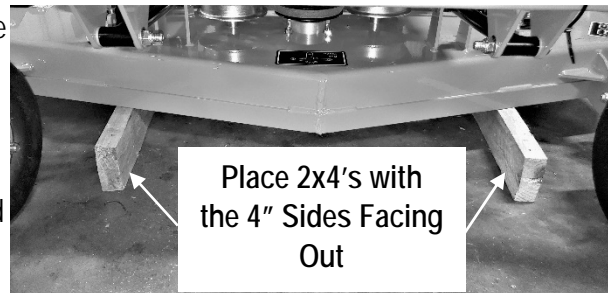
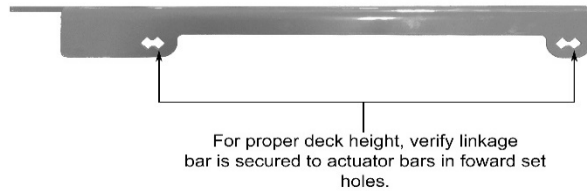



BLADE REMOVAL

To change blades, it may be best to use a piece of wood positioned between the blade and mowing deck to keep the blade from turning. Use a 15/16" socket and impact wrench capable of and output torque of at least 220 ft-lbs. A box wrench and extension can be used, though component damage potential may be increased. A 3/4" wrench can be used on the spindle shaft above the blade to keep the shaft from turning. The bolt has right-handed threads.

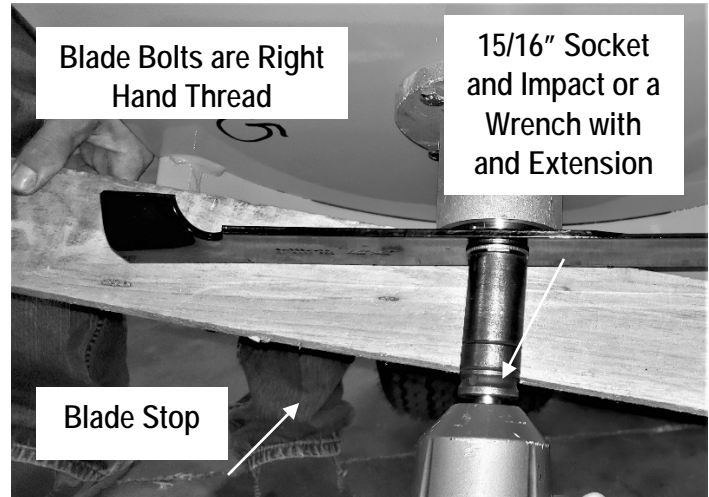

Re-torque the blade bolts to 90-110 lbs. upon re-installation.

The blade spindles contain a sealed ball bearing inside the top and bottom of the spindle. The bearings are replaceable for a more cost-effective repair. Factors such as water introduction into the bearing will have a major impact on bearing life.

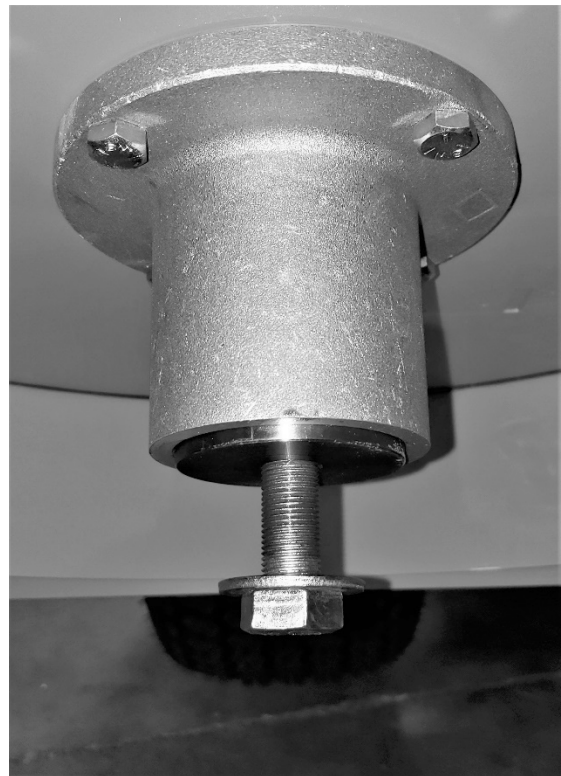



PARTS SECTION: 42" DECK ASSEMBLY

ITEM	QTY	PART NUMBER	DESCRIPTION	ITEM	QTY	PART NUMBER	DESCRIPTION
1	4	013-0004-00	Acorn nut-pulley Cover	23	12	019-5037-00	3/8" Lock Washer
2	2	013-5201-00	3/8" Flange Nut	24	3	019-5038-00	5/8" Flat Washer
3	2	013-5202-00	3/8" Nylock Flange Nut	25	2	019-6017-00	.630 ID Plastic Washer
4	1	013-5301-00	5/8-11 Nylon Insert Jam Half Nut	26	5	019-6020-00	1/2" Belleville Washer
5	12	013-6014-00	3/8" Hex Nut	27	4	019-6050-00	.360 ID Plastic Washer-Black
6	3	013-8049-00	5/16" Nylon Flange Nut	28	8	019-8054-00	.505 Nylon Spacer
7	10	013-8050-00	1/2-13 Nylon Flange Nut	29	2	022-1000-00	Deck Wheel
8	1	014-4025-00	pulley cover chute side	30	1	025-5338-00	.502 ID X .750 OD X 1.500 Long Spacer
9	1	014-4026-00	pulley cover non-chute side	31	1	025-5339-00	1 3/4" Pulley Spacer
10	2	018-0010-00	Deck Wheel Bolt	32	2	028-0004-00	MZ/ZT Deck Locator
11	1	018-1050-00	1/2 x 2" Carriage Bolt	33	3	033-4820-00	MZ Deck Pulley
12	1	018-2018-00	1/2 x 3 1/2 Flange Bolt Grade 8	34	1	033-6001-00	4 3/4 Idler Pulley - ABFI-76
13	1	018-5019-00	1/2" x 4" Bolt (Grade 8)	35	1	033-7201-25	5-3/4 Idler Pulley
14	12	018-5040-00	3/8" x 1 1/4" Hex Bolt	36	1	034-2020-00	Deck Idler Spring
15	1	018-5311-00	5/8" x 4" Hex Bolt	37	3	037-2000-00	Spindle Assembly-MZ
16	3	018-6019-00	1/2"-20 x 1 1/2 - Grade 5 Fine Thread Bolt	38	3	038-4221-00	MZ 42 Blade
17	3	018-6020-00	5/8" x 1 1/2" Grade 8 Hex Bolt (Fine)	39	4	039-2127-17	Deck Hanger Assembly
18	4	018-6054-00	1/2-13 x 3 1/2 GR 5 Hex Bolt	40	1	039-6945-18	2017 54"/48" Deck Idler Assembly
19	2	018-7060-00	3/8-16 x 5 1/2 Hex Bolt	41	1	041-4022-00	B138 Belt
20	3	018-8062-00	5/16-18x3/4 carriage bolt	42	3	042-0010-00	3/16 x 1 Square Key
21	1	019-0007-00	.517 Square Hole Round Washer	43	1	060-2442-00	2017 42" MZ Deck-Welded Shell
22	3	019-5007-00	1/2" Lock Washer Zinc	44	1	210-6015-98	MZ Discharge Chute Assembly

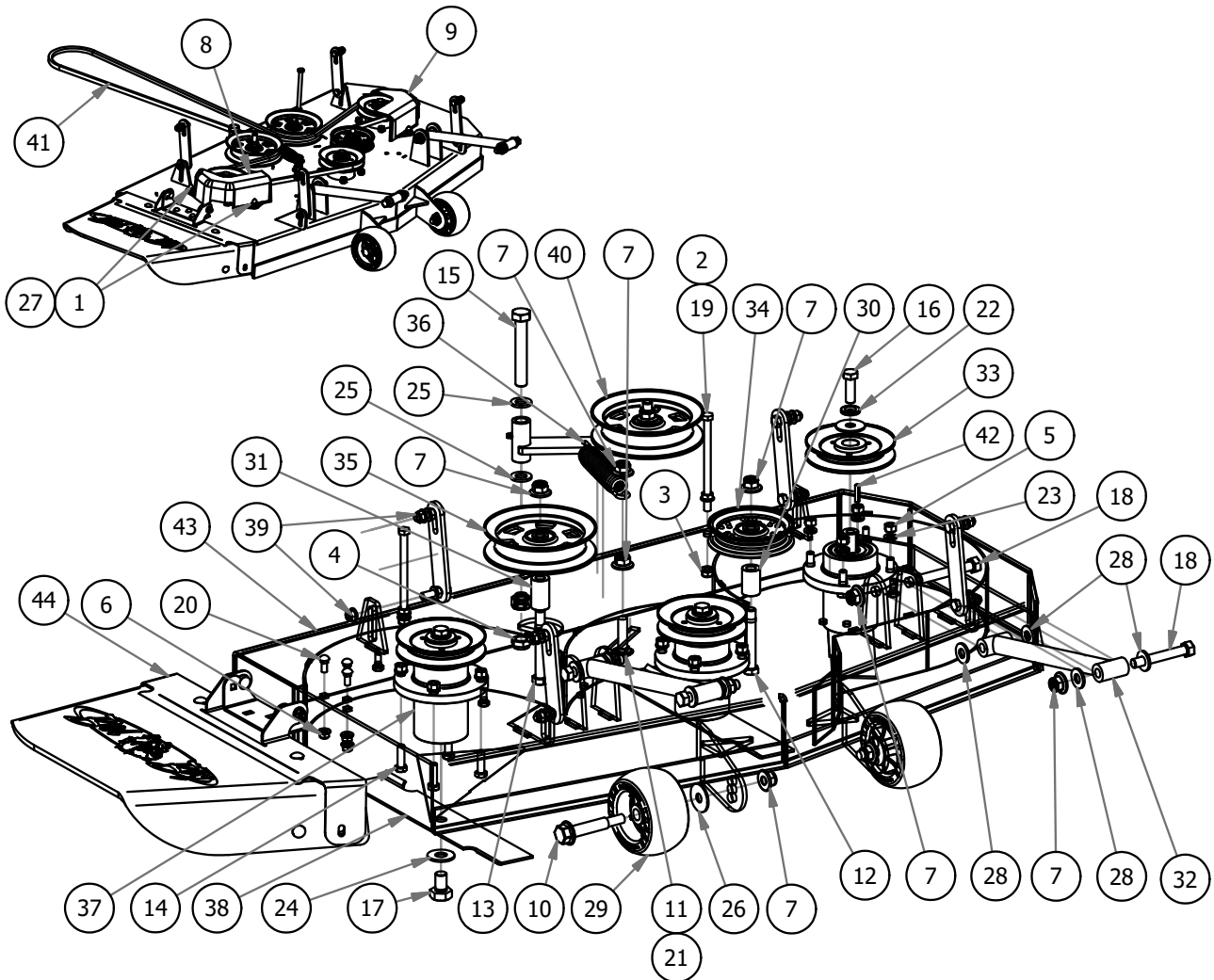



BAD BOY MOWERS

PARTS SECTION: 48" DECK ASSEMBLY

ITEM	QTY	PART NUMBER	DESCRIPTION	ITEM	QTY	PART NUMBER	DESCRIPTION
1	4	013-0004-00	Acorn nut-pulley Cover	23	12	019-5037-00	3/8" Lock Washer
2	2	013-5201-00	3/8" Flange Nut	24	3	019-5038-00	5/8" Flat Washer
3	2	013-5202-00	3/8" Nylock Flange Nut	25	2	019-6017-00	.630 ID Plastic Washer
4	1	013-5301-00	5/8" Nylock (1/2 Jam)	26	5	019-6020-00	1/2" Belleville Washer
5	12	013-6014-00	3/8" Hex Nut	27	4	019-6050-00	.360 ID Plastic Washer-Black
6	3	013-8049-00	5/16" Nylon Flange Nut	28	8	019-8054-00	.505 Nylon Spacer
7	10	013-8050-00	1/2-13 Nylon Flange Nut	29	2	022-1000-00	Deck Wheel
8	1	014-4025-00	pulley cover chute side	30	1	025-5338-00	.502 ID X .750 OD X 1.500 Long Spacer
9	1	014-4026-00	pulley cover non-chute side	31	1	025-5339-00	1 3/4" Pulley Spacer
10	2	018-0010-00	Deck Wheel Bolt	32	2	028-0004-00	MZ/ZT Deck Locator
11	1	018-1050-00	1/2 x 2" Carriage Bolt	33	3	033-4820-00	MZ Deck Pulley
12	1	018-2018-00	1/2 x 3 1/2 Flange Bolt Grade 8	34	1	033-6001-00	4-3/4 Idler Pulley
13	1	018-5019-00	1/2" x 4" Bolt (Grade 8)	35	1	033-7201-25	5-3/4 Idler Pulley
14	12	018-5040-00	3/8" x 1 1/4" Hex Bolt	36	1	034-2020-00	Deck Idler Spring
15	1	018-5311-00	5/8" x 4" Hex Bolt	37	3	037-2000-00	Spindle Assembly-MZ
16	3	018-6019-00	1/2"-20 x 1 1/2" - Grade 5 Fine Thread Bolt	38	3	038-4826-00	48" High Lift Fusion Blade
17	3	018-6020-00	5/8 x 1 1/2 Grade 8 Hex Bolt (Fine)	39	4	039-2127-17	Deck Hanger Assembly
18	4	018-6054-00	1/2-13 x 3 1/2 GR 5 Hex Bolt	40	1	039-6945-18	2017 54"/48" Deck Idler Assembly
19	2	018-7060-00	3/8-16 x 5 1/2 Hex Bolt	41	1	041-1470-00	B147 Deck Belt
20	3	018-8062-00	5/16-18x3/4 carriage bolt	42	3	042-0010-00	3/16 x 1 Square Key
21	1	019-0007-00	.517 Square Hole Round Washer	43	1	060-2448-00	48" Welded Deck Shell
22	3	019-5007-00	1/2" Lock Washer	44	1	210-6015-98	MZ Discharge Chute Assembly

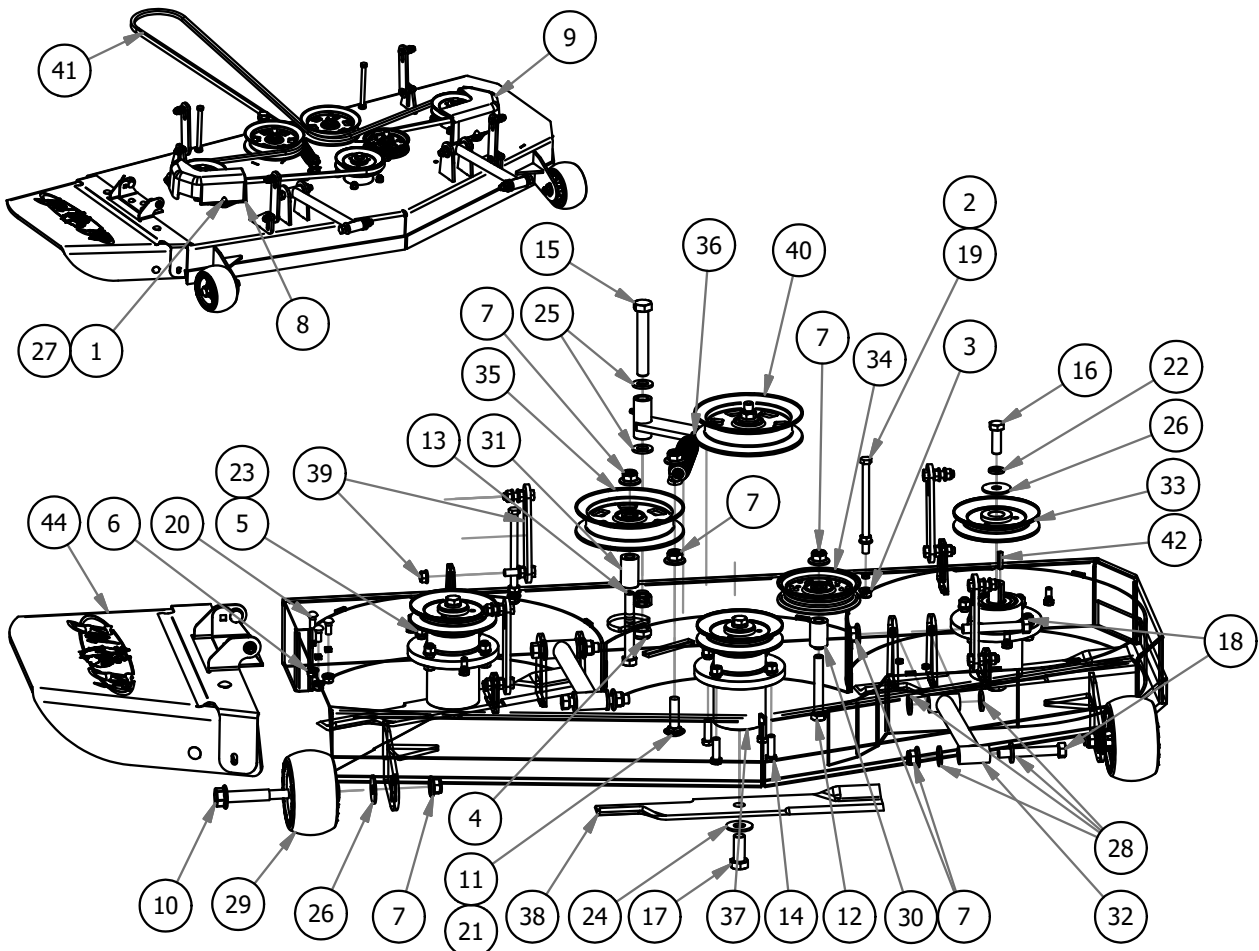



BAD BOY MOWERS

PARTS SECTION: 54" DECK ASSEMBLY

ITEM	QTY	PART NUMBER	DESCRIPTION	ITEM	QTY	PART NUMBER	DESCRIPTION
1	4	013-0004-00	Acorn nut-pulley Cover	22	12	019-5037-00	3/8" Lock Washer
2	2	013-5201-00	3/8" Flange Nut	23	3	019-5038-00	5/8" Flat Washer
3	2	013-5202-00	3/8" Nylock Flange Nut	24	2	019-6017-00	.630 ID Plastic Washer
4	1	013-5301-00	5/8" Nylock (1/2 Jam)	25	5	019-6020-00	1/2" Belleville Washer
5	12	013-6014-00	3/8" Hex Nut	26	4	019-6050-00	.360 ID Plastic Washer-Black
6	3	013-8049-00	5/16" Nylon Flange Nut	27	8	019-8054-00	.505 Nylon Spacer
7	11	013-8050-00	1/2-13 Nylon Flange Nut	28	2	022-1000-00	Deck Wheel
8	2	014-4000-00	Pulley Cover	29	2	025-5338-00	.502 ID X .750 OD X 1.500 Long Spacer
9	2	018-0010-00	Deck Wheel Bolt	30	1	025-5339-00	1 3/4" Pulley Spacer
10	1	018-1050-00	1/2 x 2" Carriage Bolt	31	2	028-0004-00	MZ/ZT Deck Locator
11	2	018-2018-00	1/2 x 3 1/2 Flange Bolt Grade 8	32	3	033-4890-00	54 MZ Spindle Pulley
12	1	018-5019-00	1/2" x 4" Bolt (Grade 8)	33	3	033-7201-25	5-3/4 Idler Pulley
13	12	018-5040-00	3/8" x 1 1/4" Hex Bolt	34	1	034-2020-00	Deck Idler Spring
14	1	018-5311-00	5/8" x 4" Hex Bolt	35	3	037-2000-00	Spindle Assembly-MZ
15	3	018-6019-00	1/2"-20 x 1 1/2 - Grade 5 Fine Thread Bolt	36	3	038-0005-00	54" MZ Fusion Blade
16	3	018-6020-00	5/8" x 1 1/2" Grade 8 Hex Bolt (Fine)	37	4	039-2127-17	Deck Hanger Assembly
17	4	018-6054-00	1/2-13 x 3 1/2 GR 5 Hex Bolt	38	1	039-6945-18	2017 54"/48" Deck Idler Assembly
18	2	018-7060-00	3/8-16 x 5 1/2 Hex Bolt	39	1	041-1560-00	B155.75 Deck Belt
19	3	018-8062-00	5/16-18x3/4 carriage bolt	40	3	042-0010-00	3/16 x 1 Square Key
20	1	019-0007-00	.517 Square Hole Round Washer	41	1	060-2417-00	2017 54" MZ Magnum Deck
21	3	019-5007-00	1/2" Lock Washer	42	1	210-6015-98	MZ Discharge Chute Assembly

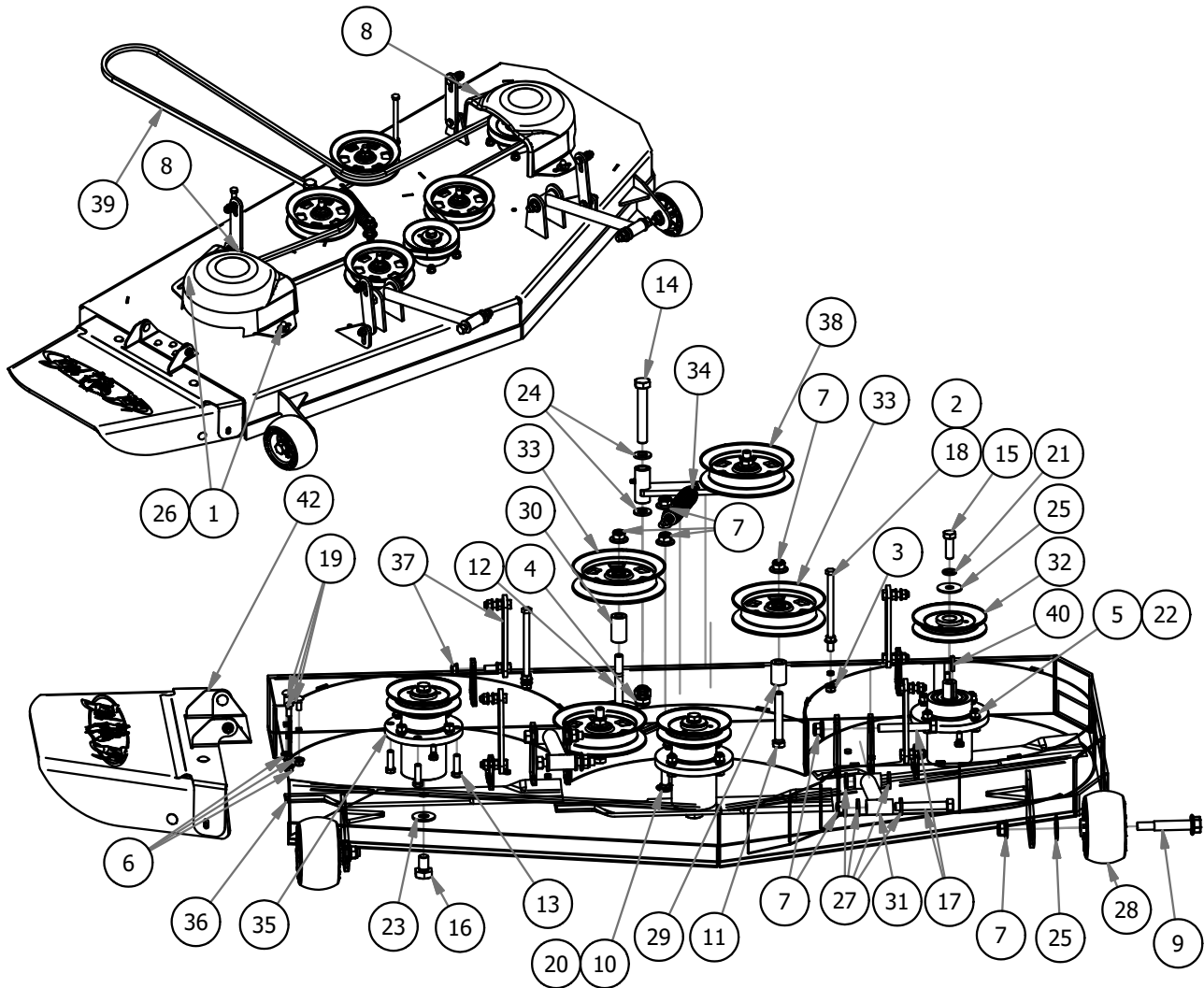



BAD BOY MOWERS

PARTS SECTION: DECK SUB-ASSEMBLIES

037-2000-00 Parts List				039-6945-18 Parts List			
ITEM	QTY	PART NUMBER	DESCRIPTION	ITEM	QTY	PART NUMBER	DESCRIPTION
1	2	037-6024-00	Spindle Bearing	9	1	013-8050-00	1/2-13 Nylon Flange Nut
2	1	037-6025-00	Spindle Shaft	10	1	018-6036-00	1/2" x 2 3/4" Hex Bolt
3	1	037-6027-00	Spindle Housing	11	1	025-5203-00	Spacer 3/4 OD x 1/2 ID x 3/4 Length
4	1	037-6028-00	Spindle Spacer-Component	12	1	033-8050-00	5" Idler Pulley
039-2127-17 Parts List				210-6015-98 Parts List			
ITEM	QTY	PART NUMBER	DESCRIPTION	ITEM	QTY	PART NUMBER	DESCRIPTION
5	1	039-2127-00	2017 MZ/IT Deck Hanger	14	6	013-8049-00	5/16" Nylon Flange Nut
6	2	018-6012-00	3/8" x 1 1/2" Hex Bolt	15	6	018-8066-00	5/16" x 7/8" Carriage Bolt
7	2	013-5201-00	3/8" Flange Nut	16	2	019-0002-00	5/16 Fender Washer
8	2	013-5202-00	3/8" Nylock Flange Nut	17	2	019-6042-00	.360 ID Plastic Washer
				18	1	039-4891-00	Discharge Chute Bracket 48 MZ (Upper)
				19	1	039-4892-00	2017 MZ Discharge Chute Bracket-Lower
				20	1	206-6020-00	Chute Hanger 48 MZ
				21	1	210-6014-00	Rubber Discharge Chute MZ (Component)

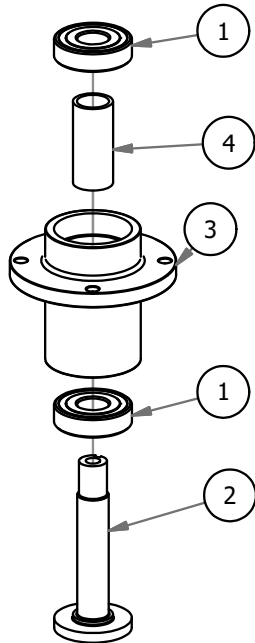

037-2000-00
Spindle Assembly-MZ

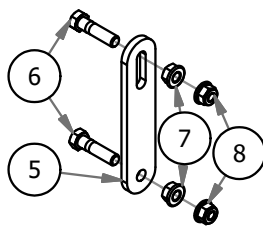

039-2127-17
Deck Hanger Assembly

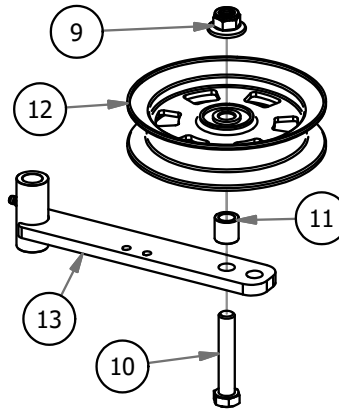

039-6945-18
Deck Idler Assembly

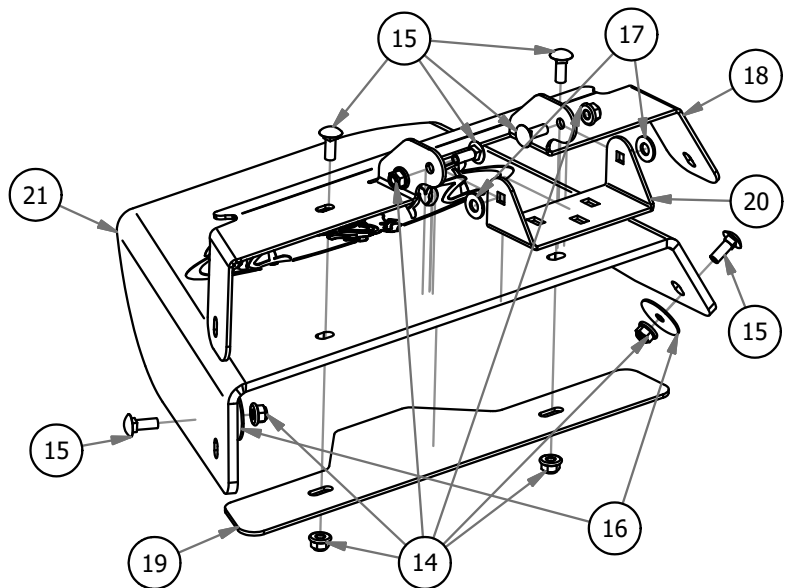

210-6015-98
MZ Discharge Chute Assembly



PARTS SECTION: TRANSAXLE & REAR WHEELS

Parts List				Parts List			
ITEM	QTY	PART NUMBER	DESCRIPTION	ITEM	QTY	PART NUMBER	DESCRIPTION
1	8	013-3000-00	Acorn Lug Nut	21	2	025-0070-00	2017 Transaxle Spacer
2	2	013-5041-00	3/8 Nylock Nut	22	2	028-0070-00	Neutral Rod
3	2	013-7018-00	1/2" Hex Nut	23	1	034-2020-00	Deck Idler Spring
4	8	013-8049-00	5/16" Nylon Flange Nut	24	2	034-3050-00	Brake Spring
5	3	013-8073-00	1/4 Nylock Nut	25	1	035-5450-00	Push Rod-Right
6	2	018-1076-00	1/4-20 x2-1/2 Gr2 hex C/s zinc	26	1	035-5451-00	Push Rod-Left
7	1	018-2004-50	All Thread-Pump Idler Tensioner	27	2	034-9080-00	Gold Transaxle Spring
8	2	018-3000-00	3/8"-16 x 2" Gr 5 Hex Bolt	28	1	039-0035-01	2017 MZ/Magnum Brake Plate Assembly
9	4	018-4701-00	5/16" x 3" Hex Bolt	29	1	039-5944-01	ZT Pump Idler
10	2	018-5040-00	3/8" x 1 1/4" Hex Bolt	30	1	041-6400-00	Pump Belt
11	2	018-5344-00	5/16" x 2 1/2" Bolt	31	2	044-2004-00	Bow Pin
12	2	018-5355-00	5/16" x 6" Bolt	32	2	044-2008-00	Neutral Rod Clip
13	1	018-8052-00	1/4" x 3/4" Hex Bolt	33	8	050-2012-00	Transaxle Wheel Studs
14	1	019-2003-00	.390 x .750 x .062 Nylon Washer	34	2	050-2078-00	MZ 4 Bolt Hub Kit
15	2	019-5037-00	3/8" Lock Washer	35	1	050-4032-98	MZ Brake Cog Kit (Sold as Kit Only)
16	2	019-7040-00	1/4" Flat Washer	36	1	050-4070-00	2017 MZ Right Transaxle
17	8	019-8044-00	5/16" Flat Washer	37	1	050-4071-00	2017 MZ Left Transaxle
18	2	022-2050-17	Wheel & Tire Assembly, 18x8.50-8, 42" MZ	38	1	064-8057-17	MZ Brake Cable
19	2	022-8050-00	Wheel & Tire assembly, 18x9.50-8, 48"-54" MZ	39	1	070-5420-00	2017 MZ/ZT 54"-60" Frame
20	1	025-0016-00	2017 Transaxle Spacer-MZ	40	1	070-5810-00	2017 MZ/ZT 42"-48" Frame

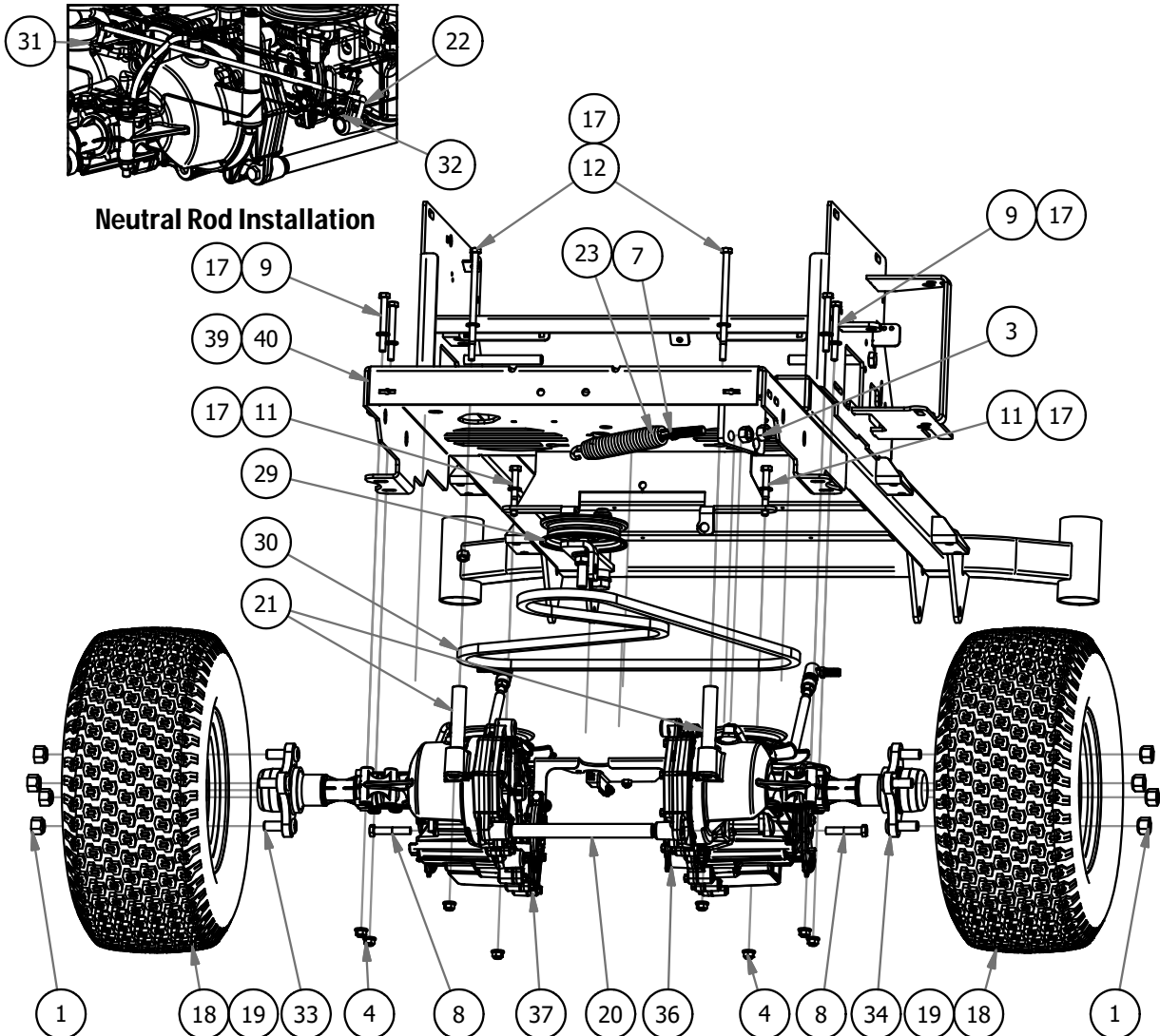



BAD BOY MOWERS

PARTS SECTION: TRANSAXLE & REAR WHEELS (CONT.)

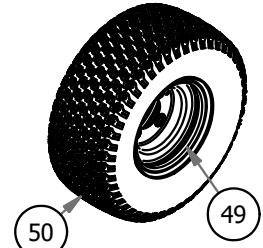
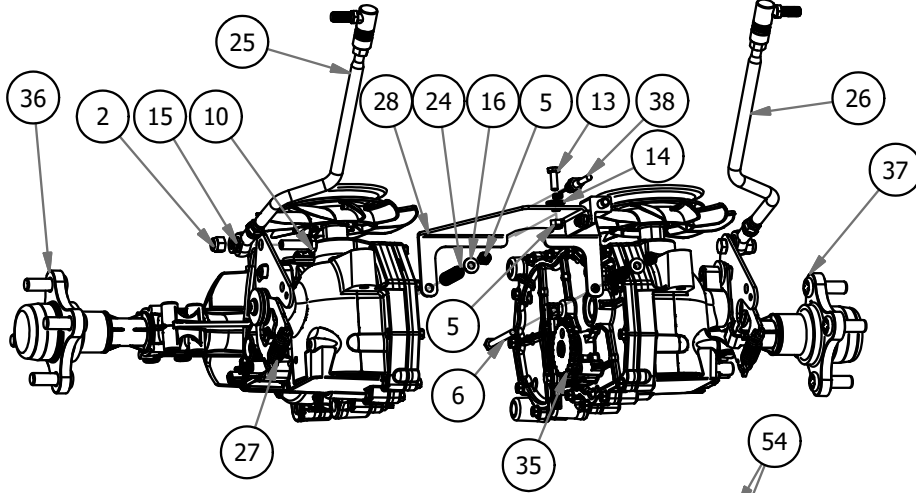

022-2050-17
Wheel & Tire Assembly
18x8.50-8

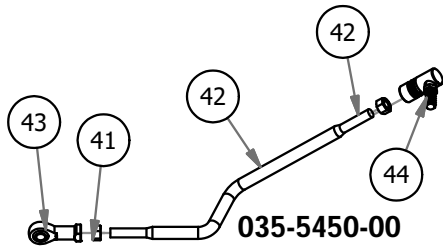

035-5450-00
Push Rod-Right

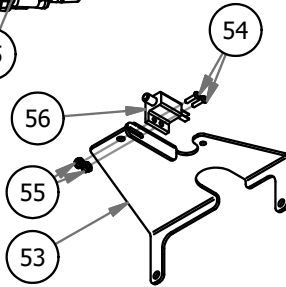

039-0035-01
2017 MZ/Magnum Brake Plate Assembly

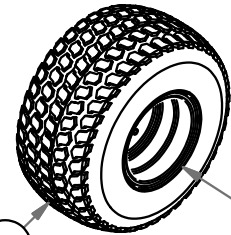

022-8050-00
Wheel & Tire Assembly
18x9.50-8

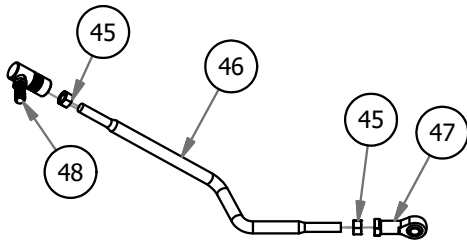

035-5451-00
Push Rod-Left

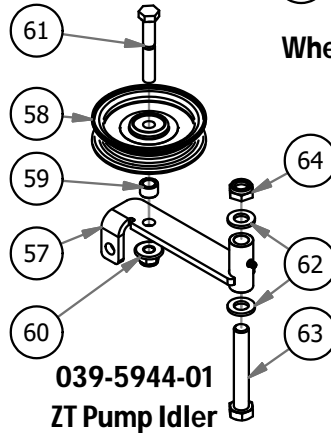

039-5944-01
ZT Pump Idler

035-5450-00 Parts List			
ITEM	QTY	PART NUMBER	DESCRIPTION
41	2	013-6051-00	3/8" Fine Threaded Jam Nut
42	1	035-5450-00	Push Rod - Right
43	1	048-3000-00	Spherical Rod End - Outlaw
44	1	099-2009-00	Quick Release Ball Joint
035-5451-00 Parts List			
ITEM	QTY	PART NUMBER	DESCRIPTION
45	2	013-6051-00	3/8" Fine Threaded Jam Nut
46	1	035-5451-00	Push Rod - Left
47	1	048-3000-00	Spherical Rod End - Outlaw
48	1	099-2009-00	Quick Release Ball Joint
022-2050-17 Parts List			
ITEM	QTY	PART NUMBER	DESCRIPTION
49	1	022-2055-17	Wheel, 8.50-8, 42" MZ
50	1	022-8027-00	Tire, 18x8.50-8, 42" MZ
022-8050-00 Parts List			
ITEM	QTY	PART NUMBER	DESCRIPTION
51	1	022-8026-00	rear rim for a 48in
52	1	022-8025-00	18 x 9.50 - 8 Tire Only MZ

039-0035-01 Parts List			
ITEM	QTY	PART NUMBER	DESCRIPTION
53	1	039-0035-00	2017 MZ Brake Lock Bracket
54	2	018-5200-00	10-24 X 5/8 BS Button Head Bolt
55	2	013-5019-00	#10 Nylock Nut
56	1	077-8073-00	Safety Switch
039-5944-01 Parts List			
ITEM	QTY	PART NUMBER	DESCRIPTION
57	1	039-5944-00	Pump Idler Bracket
58	1	033-6001-00	4 3/4" Idler Pulley
59	1	025-7036-00	1/2 x 1/2 Spacer
60	1	013-8050-00	1/2-13 Nylon Flange Nut
61	1	018-6036-00	1/2 x 2-3/4 Hex Bolt
62	2	019-6017-00	.630 ID Plastic Washer
63	1	018-5311-00	5/8" x 4" Hex Bolt
64	1	013-5301-00	5/8" Nylock (1/2 Jam)



BAD BOY MOWERS

PARTS SECTION: FRONT FORK ASSEMBLY

Parts List				Parts List			
ITEM	QTY	PART NUMBER	DESCRIPTION	ITEM	QTY	PART NUMBER	DESCRIPTION
1	4	010-1050-00	Caster Bearing 2016 - 1641 Bearing	9	2	022-8051-00	11x4-5 MZ Front Tire Assembly (42" MZ Only)
2	2	013-8050-00	1/2-13 Nylon Flange Nut	10	2	023-0002-00	2017 MZ Front fork
3	2	013-9004-00	1" Fine Thread 1/2 Nylock Nut	11	2	023-0005-00	MZ 8mm Front Fork (42" MZ Only)
4	2	014-2025-00	2017 Bearing Cover	12	2	025-0003-00	2016 Front Bearing Spacer
5	2	018-0005-00	1-14 x 5 Hex Bolt Grade 8 Zinc Yellow	13	2	025-0008-00	Front Wheel Spanner
6	2	018-0035-00	1/2 -13 x 7.5 Hex Bolt Grade 5	14	2	058-1000-00	Spacer, 1x1.375x.25
7	4	022-7009-00	Front Wheel Bearing	15	1	070-5420-00	2017 MZ/IT 54"-60" Frame
8	2	022-8049-19	11x6-5 front tire & wheel assembly (Kenda)	16	1	070-5810-00	2017 MZ/IT 42"-48" Frame

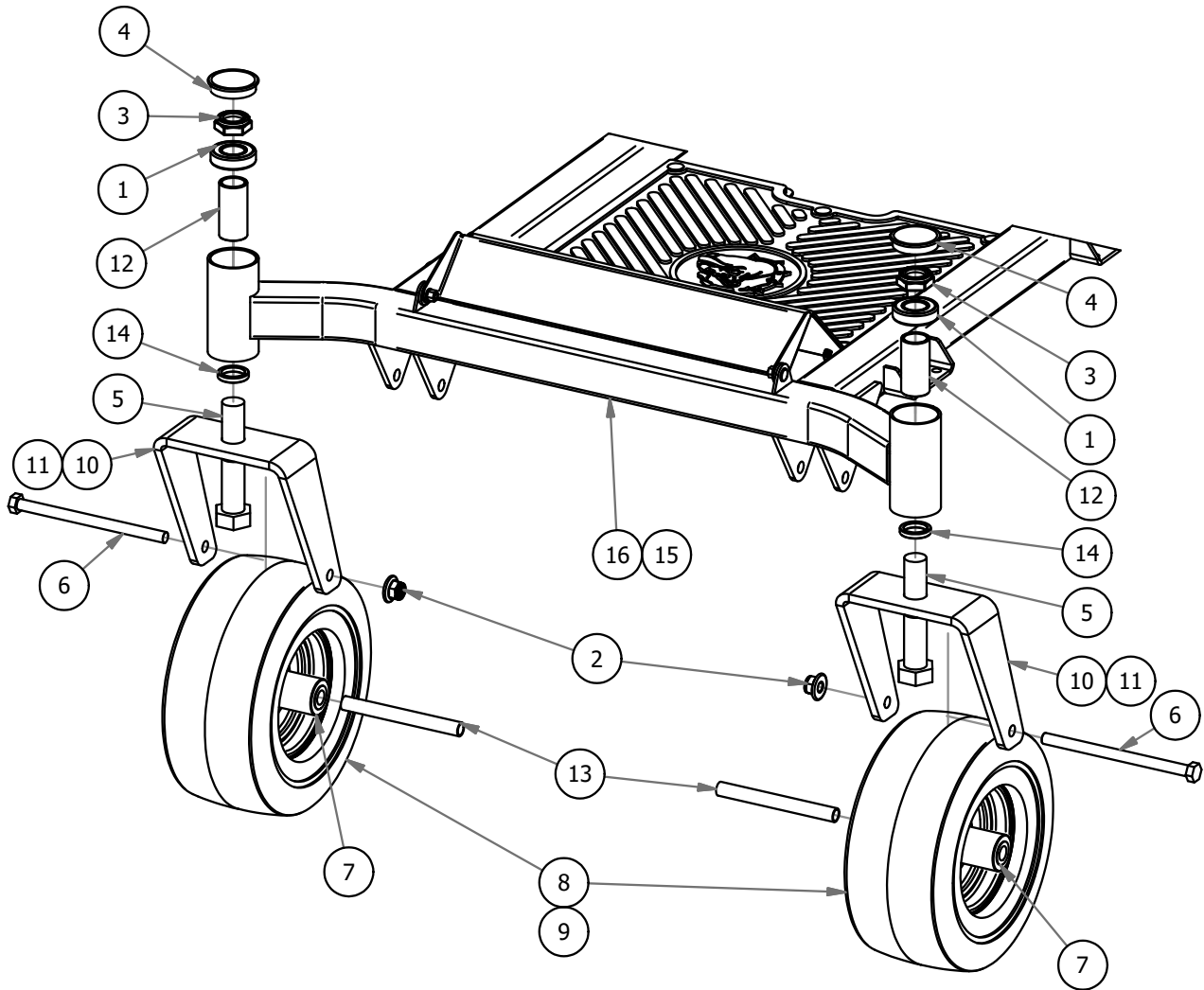



BAD BOY MOWERS

PARTS SECTION: DECK HEIGHT CONTROL ASSEMBLY

Parts List				Parts List			
ITEM	QTY	PART NUMBER	DESCRIPTION	ITEM	QTY	PART NUMBER	DESCRIPTION
1	12	013-5202-00	3/8" Nylock Flange Nut	10	1	025-0002-00	5/8" Split Collar
2	1	013-7018-00	1/2" Hex Nut	11	1	026-0019-01	Foot Pedal Assembly
3	2	013-9001-00	1/4-20 Hex Flange Nuts Zinc w/Serrations	12	1	028-0002-00	Actuator Bar Front- 2017 MZ/ZT
4	4	017-9076-00	Pillow Block Kit	13	1	028-0003-00	Actuator Bar Rear- 2017 MZ/ZT
5	8	018-0028-00	3/8-16 x 2 1/2" Hex Bolt	14	1	028-0007-17	Deck Height Dial Rod Assembly
6	4	018-5043-00	3/8" x 1 1/4" Carriage Bolt	15	1	028-0008-00	Dial Rod Plunger
7	2	018-8052-00	1/4" x 3/4" Hex Bolt	16	1	031-0510-00	2017 MZ/ZT Actuator Linkage
8	2	019-2073-00	.390 ID Plastic Washer	17	1	108-0001-00	Solenoid
9	2	019-6017-00	.630 ID x 1.122 OD x .142 THK Plastic Washer				

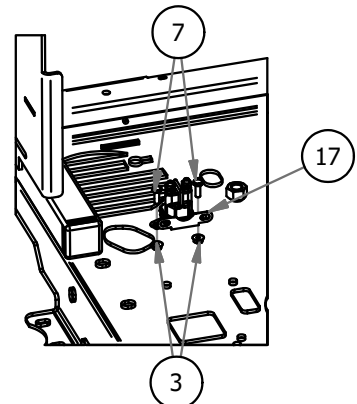
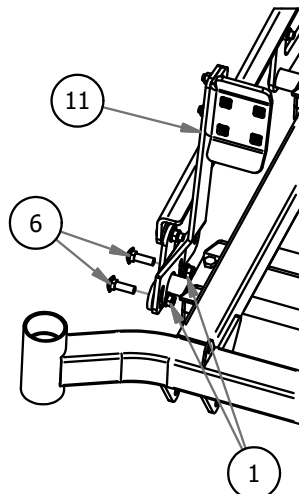
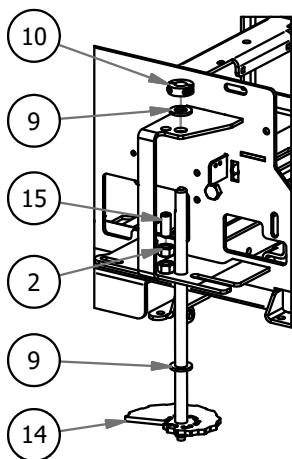
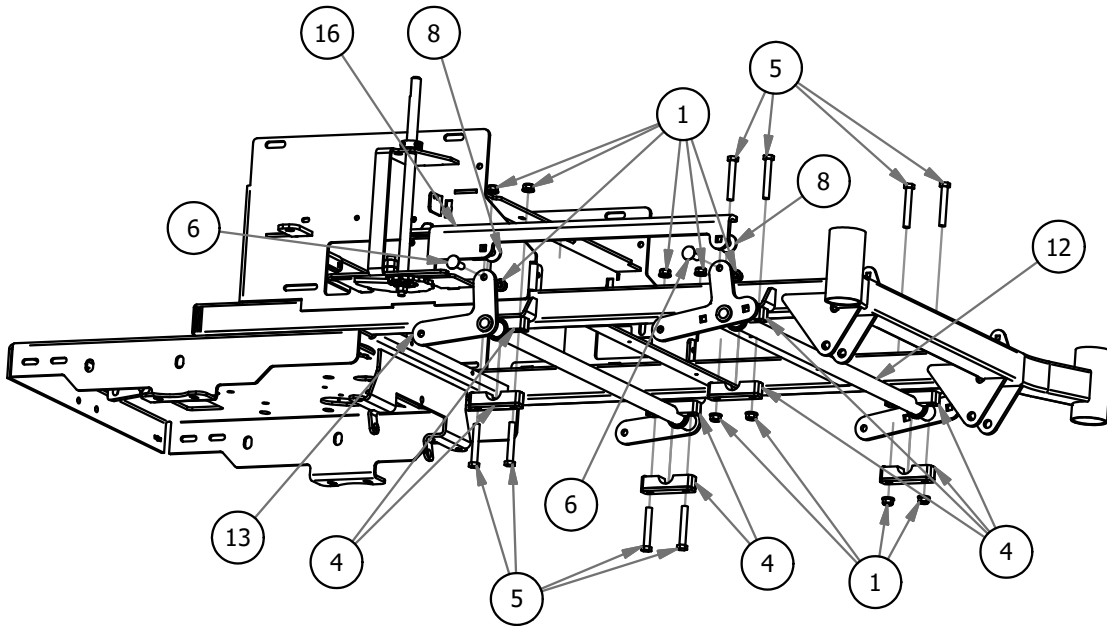



BAD BOY MOWERS

PARTS SECTION: DECK HEIGHT CONTROL ASSEMBLY (CONT.)

017-9076-00 Parts List				028-0007-17 Parts List			
ITEM	QTY	PART NUMBER	DESCRIPTION	ITEM	QTY	PART NUMBER	DESCRIPTION
18	1	017-9077-00	Pillow Block MZ male	25	1	028-0007-00	2017 Deck Height Dial Rod MZ
19	1	017-9078-00	Pillow Block MZ female	26	1	026-1100-00	2017 MZ/ZT Cam Plate
20	1	017-9079-00	Pillow Block Strap	27	1	019-5037-00	3/8" Lock Washer
026-0019-01 Parts List				019-5029-00			
ITEM	QTY	PART NUMBER	DESCRIPTION	ITEM	QTY	PART NUMBER	DESCRIPTION
21	1	031-0500-00	2017 MZ/ZT Deck Pedal Lever	28	1	019-5029-00	3/8" Flat Washer
22	1	026-0019-00	2017 MZ/ZT Shallow Foot Pedal	29	1	013-6051-00	3/8" Fine Threaded Jam Nut
23	2	013-8049-00	5/16" Nylon Flange Nut				
24	2	018-8065-00	5/16" x 1" Carriage Bolt				

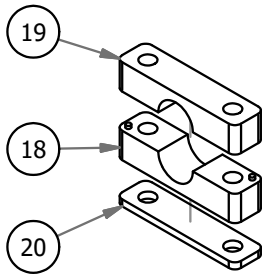

**017-9076-00
Pillow Block Kit**

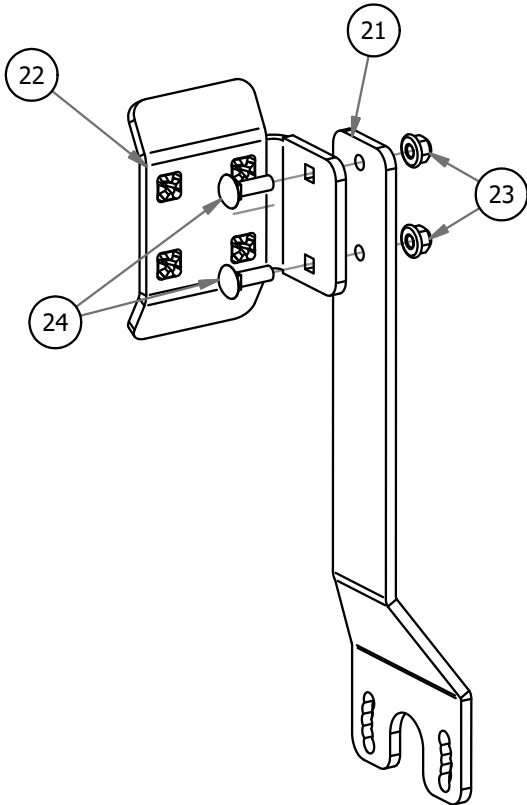

**026-0019-01
Foot Pedal Assembly**

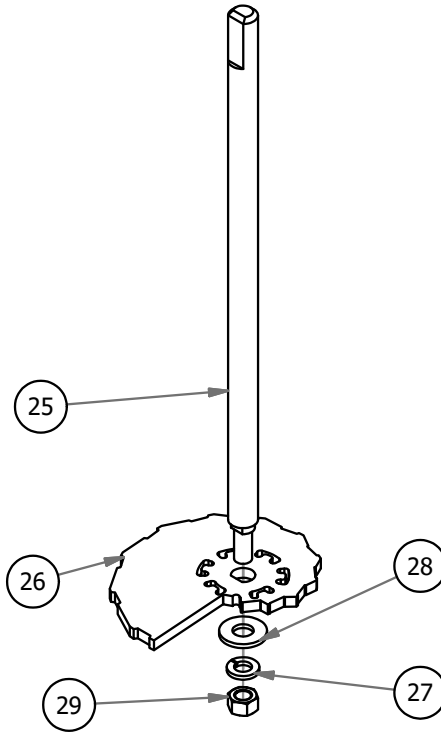

**028-0007-17
Deck Height Dial Rod Assembly**



BAD BOY MOWERS

PARTS SECTION: STEERING ARMS ASSEMBLY

Parts List				Parts List			
ITEM	QTY	PART NUMBER	DESCRIPTION	ITEM	QTY	PART NUMBER	DESCRIPTION
1	2	013-0010-00	1/2-13 Mechanical Lock Nut	12	4	019-8027-00	.515 ID Nylon Shoulder Washer
2	2	013-6014-00	3/8" Hex Nut	13	4	019-8054-00	.505 Nylon Spacer
3	3	013-6051-00	3/8" Fine Threaded Jam Nut	14	1	031-0017-01	ZT Steering Arm Assembly, Left Hand
4	2	013-8043-00	5/16" Nut	15	1	031-0018-01	ZT Steering Arm Assembly-Right Hand
5	2	013-9002-00	5/16" Flange Nut	16	2	034-8025-00	Drive Lever Spring
6	2	018-2050-00	10mm Damper Ball Stud-Steering	17	1	035-5450-00	Push Rod-Right
7	2	018-5043-00	3/8" x 1 1/4" Carriage Bolt	18	1	035-5451-00	Push Rod-Left
8	2	018-8063-00	5/16" x 3/4" Hex Bolt	19	1	070-5420-00	2017 MZ/ZT 54"-60" Frame
9	2	019-5029-00	3/8" Flat Washer	20	1	070-5810-00	2017 MZ/ZT 42"-48" Frame
10	2	019-5037-00	3/8" Lock Washer	21	2	087-0001-00	Steering Damper
11	2	019-5702-00	1/2" Washer (Grade 8)				

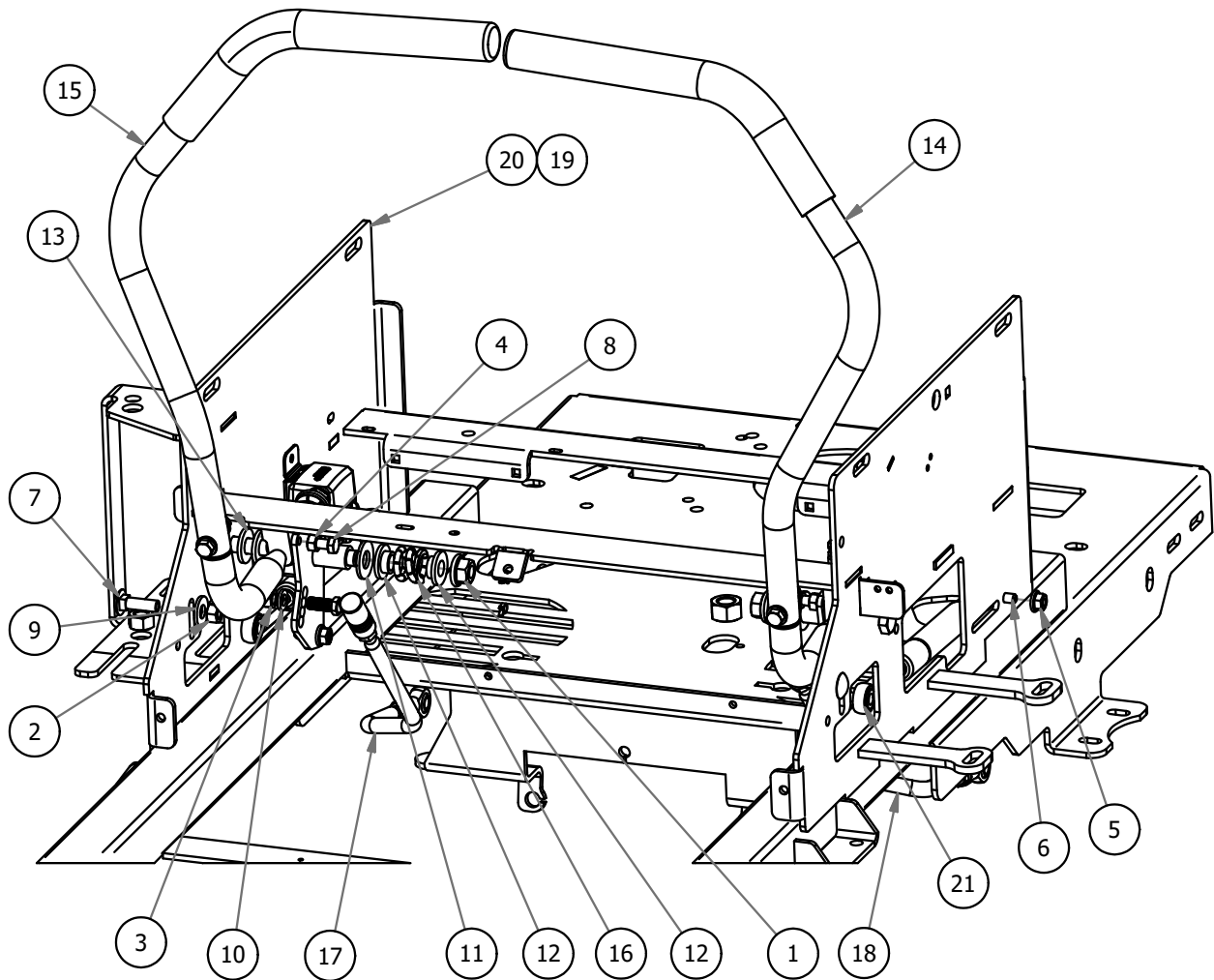



BAD BOY MOWERS

PARTS SECTION: STEERING ARMS ASSEMBLY (CONT.)

031-0017-01 Parts List				031-0018-01 Parts List			
ITEM	QTY	PART NUMBER	DESCRIPTION	ITEM	QTY	PART NUMBER	DESCRIPTION
1	1	013-8050-00	1/2-13 Nylon Flange Nut	13	1	013-8050-00	1/2-13 Nylon Flange Nut
2	1	013-9002-00	5/16" Flange Nut	14	1	013-9002-00	5/16" Flange Nut
3	1	018-2050-00	10mm Damper Ball Stud-Steering	15	1	018-2050-00	10mm Damper Ball Stud-Steering
4	2	019-8027-00	.515 ID Nylon Shoulder Washer	16	2	019-8027-00	.515 ID Nylon Shoulder Washer
5	1	019-8054-00	.505 Nylon Spacer	17	1	019-8054-00	.505 Nylon Spacer
6	1	031-0017-98	2017 Drive Lever Housing - Left	18	1	031-0018-98	2017 Drive Lever Housing - Right
7	1	031-8850-70	ZT Steering Arm-Left	19	1	031-8851-70	ZT Steering Arm-Right
7.1	2	018-2020-00	5/16-18 1/2 HWH Bolt-Steering	19.1	2	018-2020-00	5/16-18 1/2 HWH Bolt-Steering
7.2	2	019-8051-00	5/16" Lock Washer	19.2	2	019-8051-00	5/16" Lock Washer
7.3	1	031-8850-02	ZT Direction Steering Arm (Left)	19.3	1	031-8851-02	ZT Direction Steering Arm (Right)
7.4	1	031-9020-70	Stering Arm Elbow (Left)	19.4	1	031-9025-70	Stering Arm Elbow (Right)
7.5	1	069-4007-00	Rubber Grip	19.5	1	069-4007-00	Rubber Grip
8	1	034-8025-00	Drive Lever Spring	20	1	034-8025-00	Drive Lever Spring
035-5450-00 Parts List				035-5451-00 Parts List			
ITEM	QTY	PART NUMBER	DESCRIPTION	ITEM	QTY	PART NUMBER	DESCRIPTION
9	2	013-6051-00	3/8" Fine Threaded Jam Nut	21	2	013-6051-00	3/8" Fine Threaded Jam Nut
10	1	035-5450-00	Push Rod - Right	22	1	035-5451-00	Push Rod - Left
11	1	048-3000-00	Spherical Rod End - Outlaw	23	1	048-3000-00	Spherical Rod End - Outlaw
12	1	099-2009-00	Quick Release Ball Joint	24	1	099-2009-00	Quick Release Ball Joint

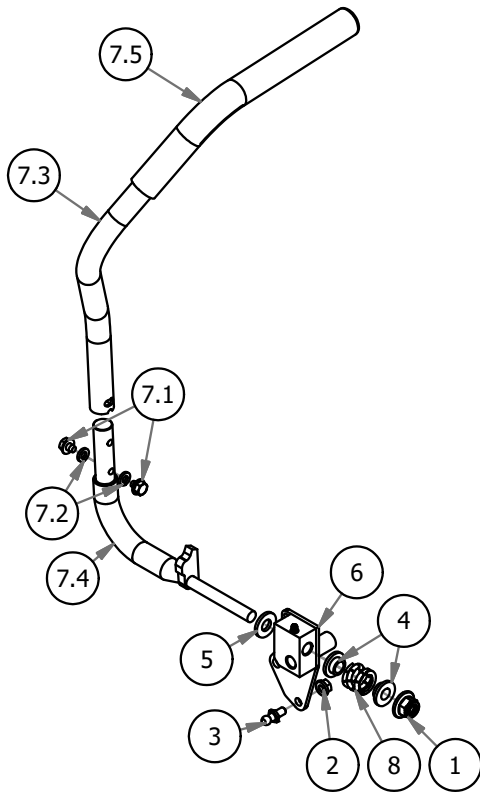

031-0017-01
ZT Steering Arm Assembly, Left Hand

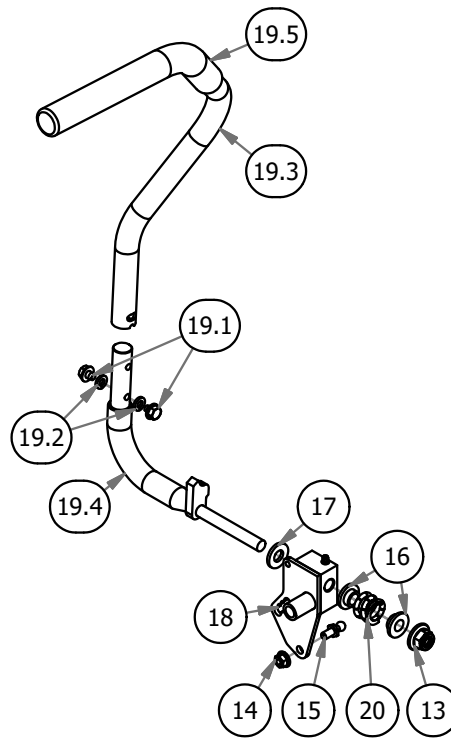

031-0018-01
ZT Steering Arm Assembly-Right Hand

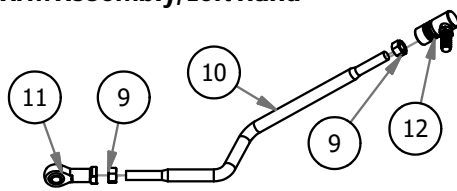

035-5450-00
Push Rod-Right

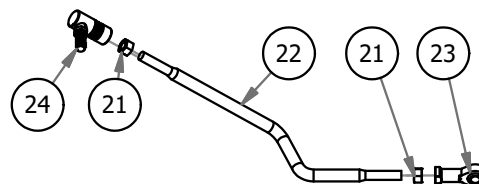

035-5451-00
Push Rod-Left



BAD BOY MOWERS

PARTS SECTION: SEAT PAN & COVERS

Parts List				Parts List			
ITEM	QTY	PART NUMBER	DESCRIPTION	ITEM	QTY	PART NUMBER	DESCRIPTION
1	2	013-2050-00	1/4-20 Nylon Insert flange Nut	14	1	026-2017-00	2017 MZ Seat Plate
2	2	013-5019-00	10-24 Nylon Insert Locknut Zinc Orange Nylon	15	4	029-4010-00	Button Bumper
3	6	013-8049-00	5/16" Nylon Flange Nut	16	4	030-3050-00	#10 x 1/2" Self Tapping Screw
4	1	013-9001-00	1/4-20 Hex Flange Nuts Zinc w/Serrations	17	3	030-7042-00	5/16 x 3/4 washer head type F screw
5	1	014-3317-00	2017 MZ Cooler Cover	18	12	040-6080-00	Ratchet Fastener
6	4	018-1080-00	12-24x 1/2 HWH Bolt	19	1	055-2012-00	Universal Throttle
7	1	018-2012-00	1/4" x 1/2" BS C/S 18-8 SS	20	1	055-2013-00	Throttle Knob
8	2	018-5200-00	10-24 X 5/8 BS Button Head Bolt	21	1	064-8057-17	MZ Brake Cable
9	4	018-8065-00	5/16" x 1" Carriage Bolt	22	2	077-8073-00	Safety Switch
10	2	018-8066-00	5/16" x 7/8" Carriage Bolt	23	1	079-3417-00	MZ/IZT 2017 Floorboard
11	4	019-6042-00	.360ID Plastic Washer	24	1	081-4000-00	2017 MZ/IZT Floor Mat
12	2	019-8040-00	1/4" x 3/4" Carriage Bolt	25	1	086-3050-19	Wiring Harness
13	1	026-0117-00	2017 MZ Rear Plate				

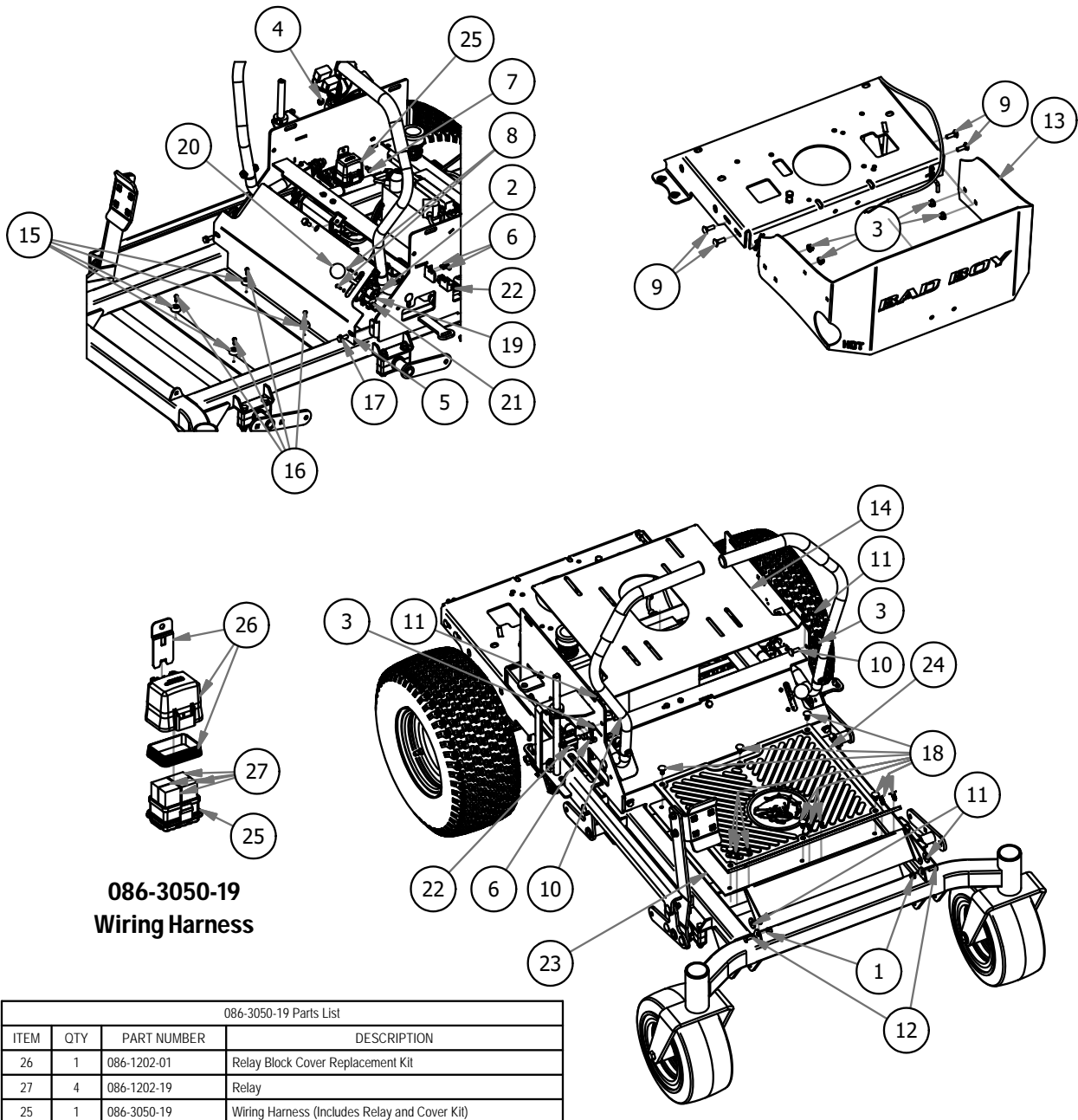

086-3050-19
Wiring Harness

086-3050-19 Parts List			
ITEM	QTY	PART NUMBER	DESCRIPTION
26	1	086-1202-01	Relay Block Cover Replacement Kit
27	4	086-1202-19	Relay
25	1	086-3050-19	Wiring Harness (Includes Relay and Cover Kit)



BAD BOY MOWERS

PARTS SECTION: TANKS & ELECTRONICS

Parts List				Parts List			
ITEM	QTY	PART NUMBER	DESCRIPTION	ITEM	QTY	PART NUMBER	DESCRIPTION
1	1	013-6051-00	3/8" Fine Threaded Jam Nut	20	1	064-5301-00	12" Red Battery Cable
2	4	013-9001-00	1/4-20 Hex Flange Nuts Zinc w/Serrations	21	1	066-8083-00	Tethered Fuel Tank Cap
3	2	014-8047-00	Seat Spring Cap Cover	22	1	067-0015-01	MZ Kohler EPA Canister Assembly (Kohler KS-590 Only)
4	2	014-9000-00	2X2 Frame Plug	23	1	067-0015-02	MZ Kohler EPA Canister Assembly
5	2	018-0024-00	M6-1.0 X 16MM Hex Bolt	24	1	067-2080-50	2017 MZ Right Gas Tank
6	7	018-2007-00	5/16" x 1" Bolt	25	1	067-2090-50	2017 MZ Left Gas Tank
7	4	018-2010-00	10-32 x 3/8" Button Socket Head Bolt	26	1	067-4090-00	Fuel Gauge
8	4	018-8052-00	1/4" x 3/4" Hex Bolt	27	1	067-6056-00	Fuel Gauge Grommet
9	7	019-8044-00	5/16" Flat Washer	28	1	067-6060-00	Rollover Valve
10	7	019-8051-00	5/16" Lock Washer	29	1	068-8049-00	Battery
11	2	034-8045-03	Seat Spring Assembly	30	1	070-5810-00	2017 MZ/ZT 42"-48" Frame
13	1	042-9000-00	Ignition Key	31	1	072-8070-00	3/16 Vinyl Clamp
14	1	043-8929-00	Hold Down Assembly	32	1	077-9000-00	MZ/ZT Deck Height Dial
15	1	051-0001-00	15" Fuel Line Assembly (Kawasaki Engine)	33	1	079-3460-01	2017 Magnum Control Panel Assembly
16	1	051-2014-00	37" Fuel Line Assembly (Kohler Engine)	34	1	079-3460-02	2017 MZ Control Panel Assembly
17	1	054-8017-00	Choke	35	1	108-0001-00	Solenoid
18	1	064-0030-00	Ground Cable	36	1	216-1000-17	Tach Wire (Only used with Magnum Control Panel)
19	1	064-5300-00	24" Red Battery Cable				

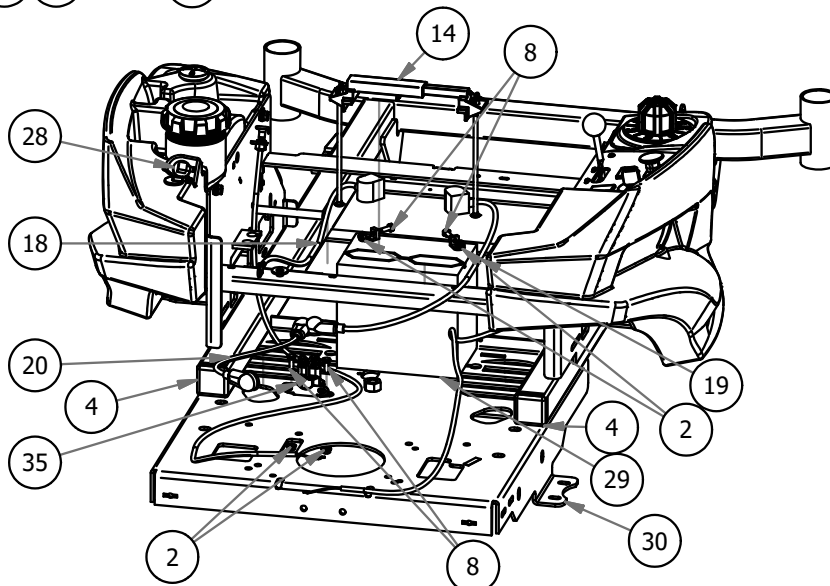
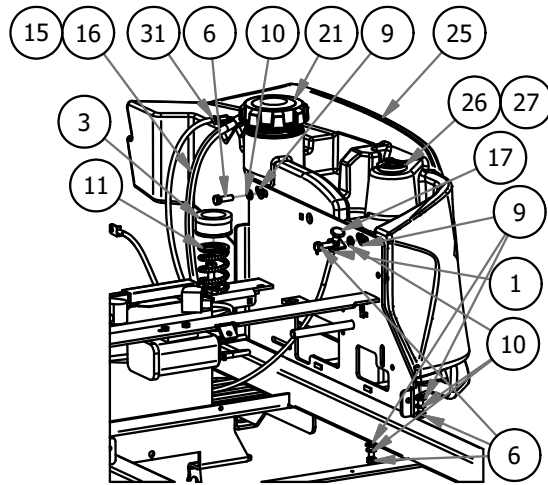
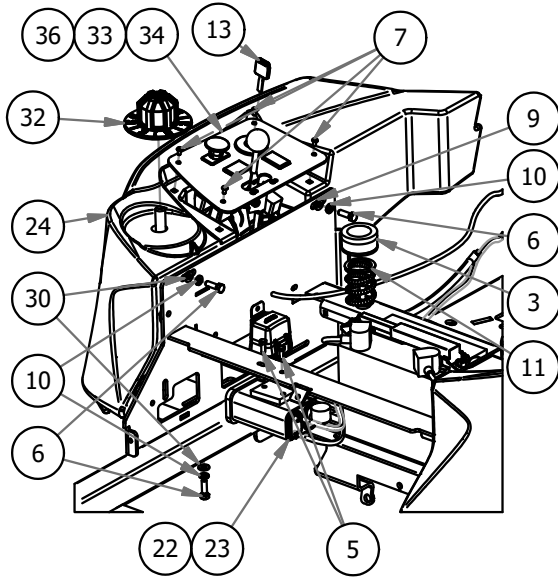



BAD BOY MOWERS

PARTS SECTION: TANKS & ELECTRONICS (CONT.)

034-8045-03 Parts List				067-0015-02 Parts List			
ITEM	QTY	PART NUMBER	DESCRIPTION	ITEM	QTY	PART NUMBER	DESCRIPTION
1	1	013-0017-00	3/8-16 Half Jam Nut	23	1	051-2023-02	3/16 Vinyl Tubing, 44"
2	1	013-5201-00	3/8" Flange Nut	24	1	051-2027-02	3/16" Clear Vinyl Tubing, 52"
3	1	018-3000-00	3/8"-16 x 2" Gr 5 Hex Bolt	25	1	067-0015-00	Carbon Canister for Magnum/MZ
4	1	019-5029-00	3/8" Flat Washer	26	1	072-8073-00	3/16" Vinyl Hose Clamp
5	1	034-8045-00	Seat Spring	27	2	072-8075-00	8.6mm Hose Clamp
043-8929-00 Parts List				079-3460-01 Parts List			
ITEM	QTY	PART NUMBER	DESCRIPTION	ITEM	QTY	PART NUMBER	DESCRIPTION
11	2	013-8051-00	1/4" Wing Nut	28	2	013-5019-00	10-24 Nylon Insert Locknut Zinc Orange Nylon
12	2	018-8050-00	1/4-20 X 8 Carriage Bolt	29	1	018-1040-00	Light Plug
13	1	043-8929-00	Battery Hold Down	30	2	018-5200-00	10-24 X 5/8 BS Button Head Bolt
051-0001-00 Parts List				079-3460-02 Parts List			
ITEM	QTY	PART NUMBER	DESCRIPTION	ITEM	QTY	PART NUMBER	DESCRIPTION
14	2	072-8069-00	1/4 Fuel Hose Clamp	31	1	055-8020-00	Throttle Lever Assembly
15	1	051-8067-00	1/4 Fuel Line	32	1	056-8058-00	PTO Engager
051-2014-00 Parts List				079-3460-02 Parts List			
ITEM	QTY	PART NUMBER	DESCRIPTION	ITEM	QTY	PART NUMBER	DESCRIPTION
16	1	051-2014-01	37" 1/4 Fuel Line	36	2	013-5019-00	10-24 Nylon Insert Locknut Zinc Orange Nylon
17	2	072-8069-00	1/4 Fuel Hose Clamp	37	2	018-1040-00	Light Plug
067-0015-01 Parts List				079-3460-02 Parts List			
ITEM	QTY	PART NUMBER	DESCRIPTION	ITEM	QTY	PART NUMBER	DESCRIPTION
18	1	051-2023-01	3/16 Vinyl Tubing, 53"	38	2	018-5200-00	10-24 X 5/8 BS Button Head Bolt
19	1	051-2027-01	3/16" Clear Vinyl Tubing, 44"	39	1	055-8020-00	Throttle Lever Assembly
20	1	067-0015-00	Carbon Canister for Magnum/MZ	40	1	056-8058-00	PTO Engager
21	1	072-8073-00	3/16" Vinyl Hose Clamp	41	1	077-8076-00	Ignition Switch
22	2	072-8075-00	8.6mm Hose Clamp	42	1	079-3460-00	Control Panel

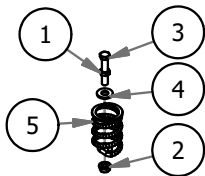

034-8045-03
Seat Spring Assembly

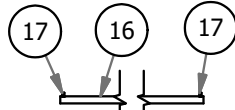

051-2014-00
37" Fuel Line Assembly

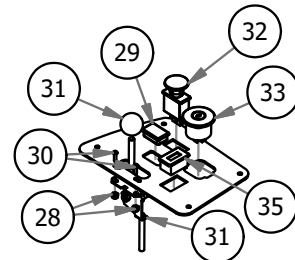

079-3460-01
2017 Magnum Control Panel Assembly

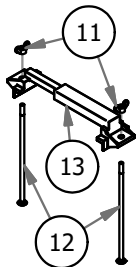

043-8929-00
Hold Down Assembly

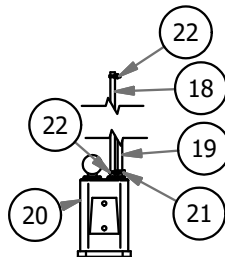

067-0015-01
MZ Kohler 42" EPA Canister Assembly

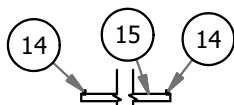

051-0001-00
15" Fuel Line Assembly

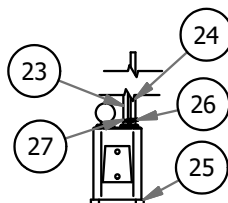

067-0015-02
EPA Canister Assembly

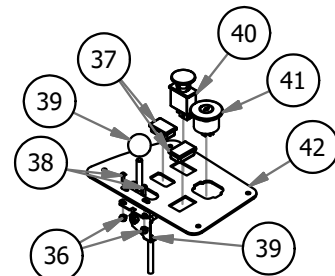

079-3460-02
2017 MZ Control Panel Assembly



BAD BOY MOWERS

PARTS SECTION: SEAT ASSEMBLY

Parts List				Parts List			
ITEM	QTY	PART NUMBER	DESCRIPTION	ITEM	QTY	PART NUMBER	DESCRIPTION
1	4	018-8063-00	5/16" x 3/4" Hex Bolt	5	1	071-1000-00	2019 MZ Magnum Seat
2	4	019-7040-00	1/4" Flat Washer	6	1	071-8062-00	Seat Safety Switch
3	4	019-8051-00	5/16" Lock Washer	7	1	071-9002-00	2019 42" MZ Seat
4	1	026-2017-00	2017 MZ Seat Plate				

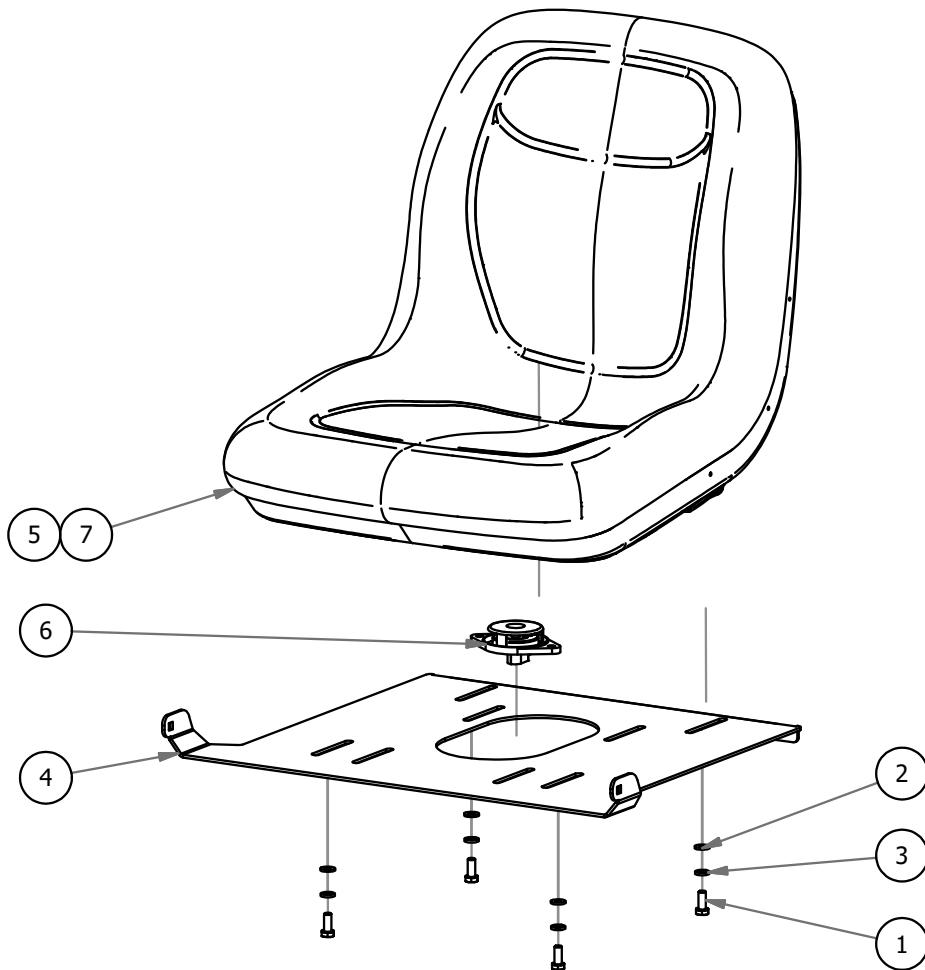



BAD BOY MOWERS

PARTS SECTION: SEAT ASSEMBLY (KAWASAKI MAGNUM ONLY)

Parts List				Parts List			
ITEM	QTY	PART NUMBER	DESCRIPTION	ITEM	QTY	PART NUMBER	DESCRIPTION
1	4	013-8049-00	5/16" Nylon Flange Nut	5.1	1	071-2015-00	Seat Rail Pair
2	1	026-1016-00	Seat Plate 2016	5.2	1	071-2050-00	Seat Back Cushion
3	2	030-7041-00	1/4-20x1/2 HWH Bolt Slot	5.3	1	071-2051-00	Seat Bottom Cushion
4	1	039-2155-00	MZ Seat Stop Bracket	5.4	1	071-2054-00	Arm Rest (Pair)
5	1	071-2040-17	2017 ZT Seat	6	1	071-8061-00	Seat Safety Switch

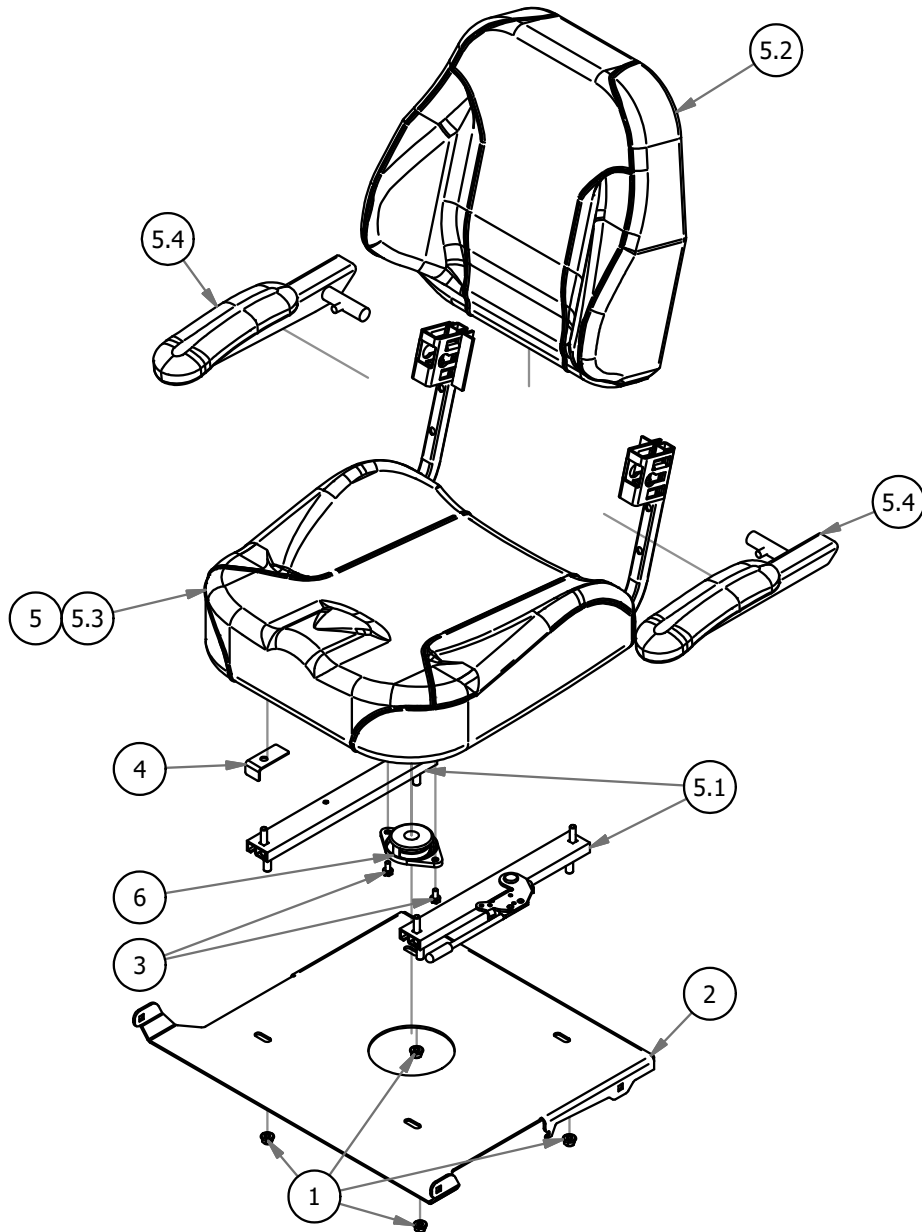



PARTS SECTION: ENGINE - KOHLER KS-590

Parts List				Parts List			
ITEM	QTY	PART NUMBER	DESCRIPTION	ITEM	QTY	PART NUMBER	DESCRIPTION
1	2	013-0075-00	M8-1.25 Zinc Nut	17	2	019-8051-00	5/16" Lock Washer
2	2	013-5041-00	3/8 Nylock Nut	18	1	030-6029-00	3/8" Set Screw
3	1	013-9002-00	5/16" Flange Nut	19	1	033-2010-00	3-3/4" Motor Pulley
4	1	015-0077-00	Kohler KS-590 541cc 19Hp	20	1	041-6400-00	Pump Belt
5	1	015-0077-01	Exhaust Gasket	21	1	042-6030-00	1/4" x 1" Key
6	1	015-0077-02	Kohler KS-590 Muffler	22	1	051-2014-00	37" Fuel Line Assembly
7	1	015-0077-03	Kohler KS-590 Spark Plug	23	1	051-5401-00	Oil drain Hose
8	1	015-0077-04	Kohler KS-590 Oil Filter	24	1	054-8017-00	Choke
9	1	015-0077-05	Kohler KS-590 Air Pre-Cleaner	25	1	057-5900-00	2017 MZ Clutch Stop
10	1	015-0077-06	Kohler KS-590 Air Filter	26	1	063-6000-00	Universal In-line Fuel Filter
11	1	018-0007-00	7/16"-20 x 3" Hex Bolt Gr. 8	27	1	064-0030-00	Ground Cable
12	1	018-0012-00	5/16-18 X 2 Hex C/S (GR.5) ZC	28	1	064-5301-00	12" Red Battery Cable
13	1	018-0101-00	M6-1.0x16mm Self-Tapping Bolt	29	1	067-0015-01	MZ Kohler EPA Canister Assembly
14	3	018-1075-00	3/8 x 1 1/8 bolt	30	1	070-0055-00	Clutch
15	2	018-6049-00	3/8" x 1" Hex Bolt	31	1	079-3460-02	2017 MZ Control Panel Assembly
16	1	019-6020-00	1/2" Belleville Washer				

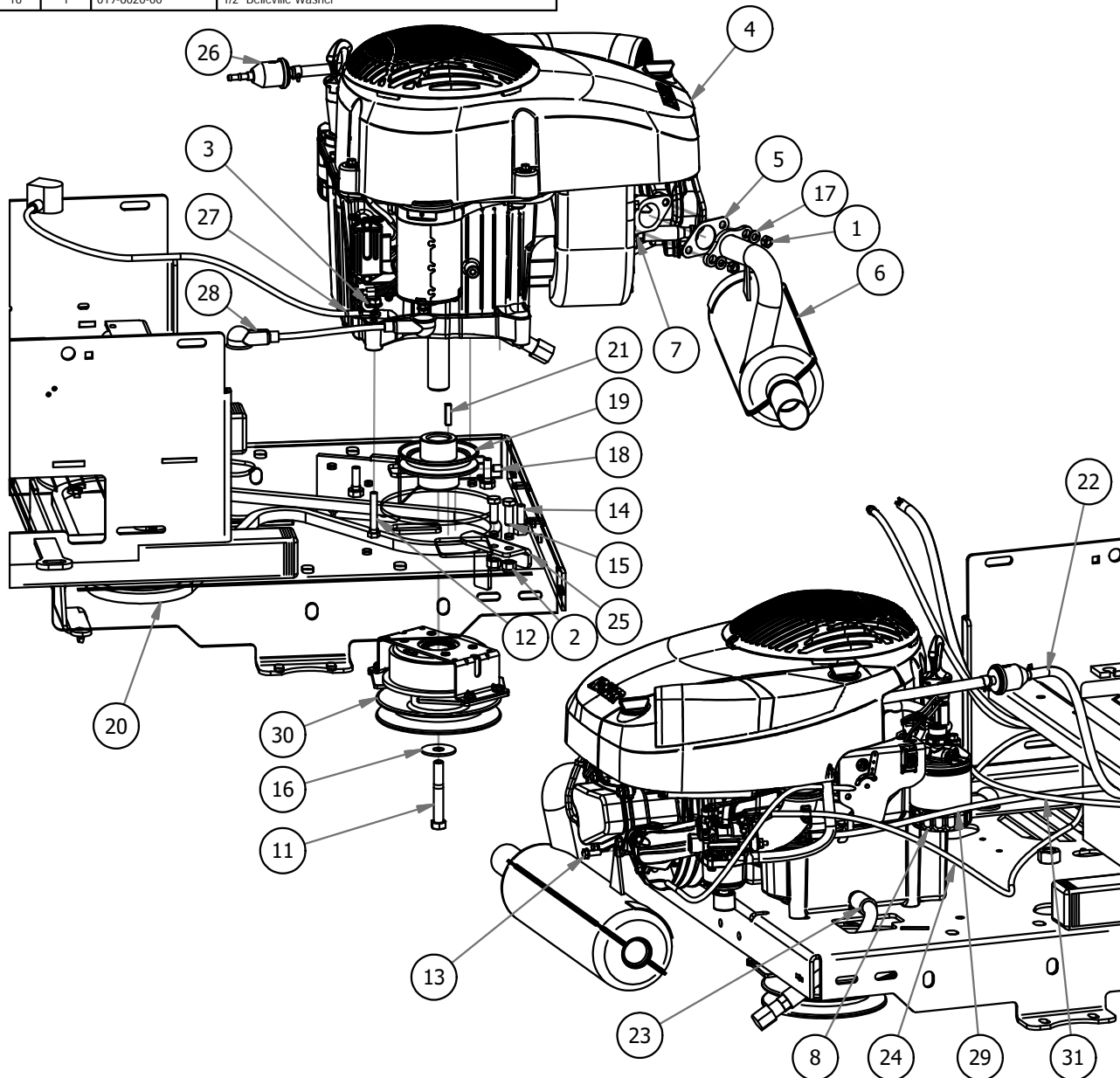



BAD BOY MOWERS

PARTS SECTION: ENGINE-KOHLER KT-725 & KT-740

Parts List				Parts List			
ITEM	QTY	PART NUMBER	DESCRIPTION	ITEM	QTY	PART NUMBER	DESCRIPTION
1	2	013-5041-00	3/8 Nylock Nut	17	1	051-2014-00	37" Fuel Line Assembly
2	4	013-8240-00	M8 Flange Nut for Kohler Exhaust	18	1	051-5401-00	Oil drain Hose
3	1	013-9001-00	1/4-20 Hex Flange Nuts Zinc w/Serrations	19	1	054-8017-00	Choke
4	1	015-0051-00	Kohler Muffler	20	1	057-5900-00	2017 MZ Clutch Stop
5	1	015-2014-00	Kohler MZ Magnum 740cc	21	1	063-5002-00	KT-725 & KT-740 Precleaner
6	1	015-2015-00	Kohler KT-725	22	1	063-5003-00	KT-725 & KT-740 Air Element
7	2	015-2751-00	Exhaust Gasket	23	1	063-5004-00	KT-725 & KT-740 Oil Filter
8	2	015-8000-00	Spark Plug	24	1	063-6000-00	Universal Fuel Filter
9	1	018-0007-00	7/16"-20 x 3" Hex Bolt Gr. 8	25	1	064-0030-00	Ground Cable
10	4	018-1075-00	3/8 x 1 1/8 bolt	26	1	064-5301-00	12" Red Battery Cable
11	2	018-6049-00	3/8" x 1" Hex Bolt	27	1	067-0015-02	MZ Kohler EPA Canister Assembly
12	1	019-6020-00	1/2 Belleville Washer	28	1	070-0055-00	Clutch
13	1	030-6029-00	3/8" Set Screw	29	1	070-5420-00	2017 MZ/ZT 54"-62" Frame
14	1	033-2010-00	3-3/4" Motor Pulley	30	1	070-5810-00	2017 MZ/ZT 42"-48" Frame
15	1	041-6400-00	Pump Belt	31	1	079-3460-01	2017 MZ Magnum Control Panel
16	1	042-6030-00	1/4" x 1" Key	32	1	079-3460-02	2017 MZ Control Panel Assembly

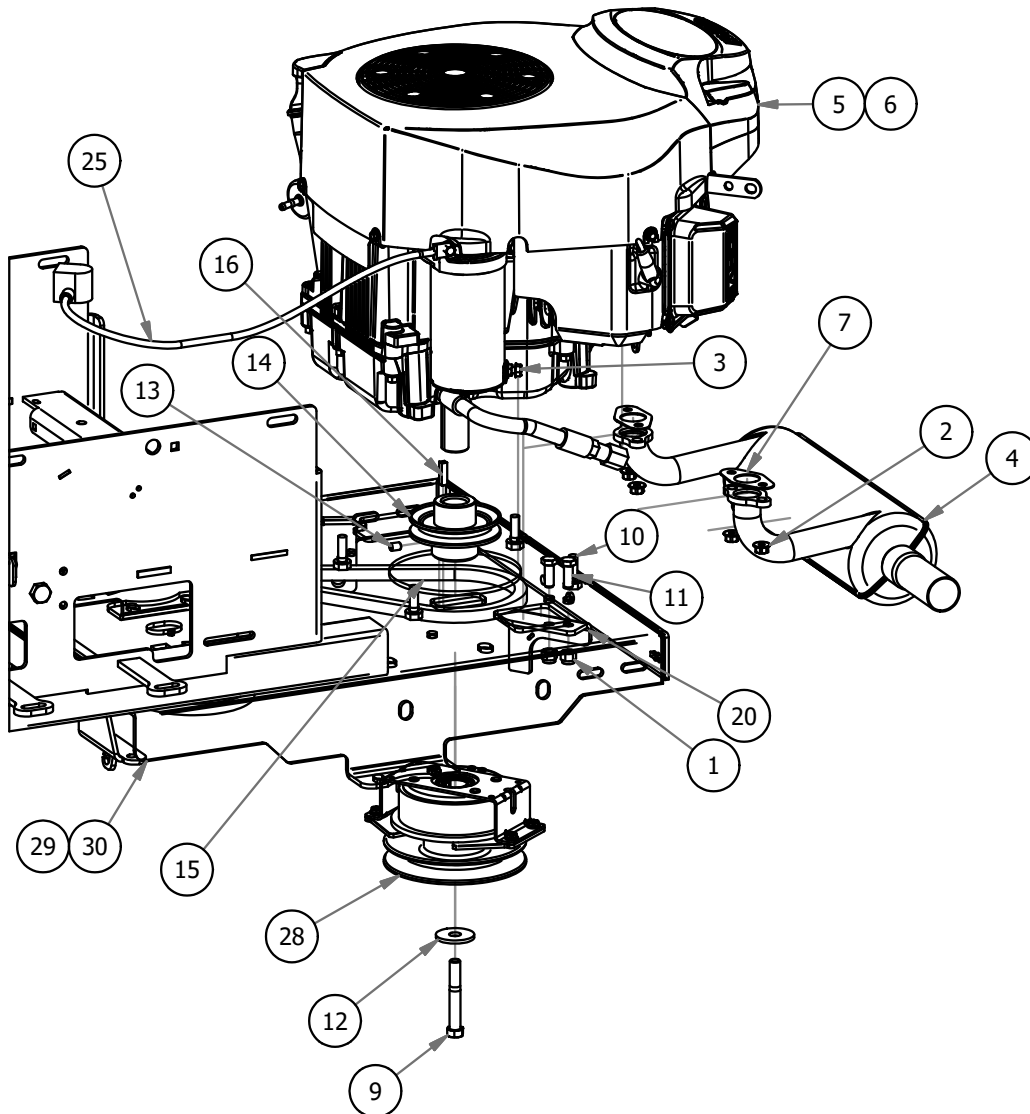



BAD BOY MOWERS

PARTS SECTION: ENGINE-KOHLER KT-725 & KT-740 (CONT.)

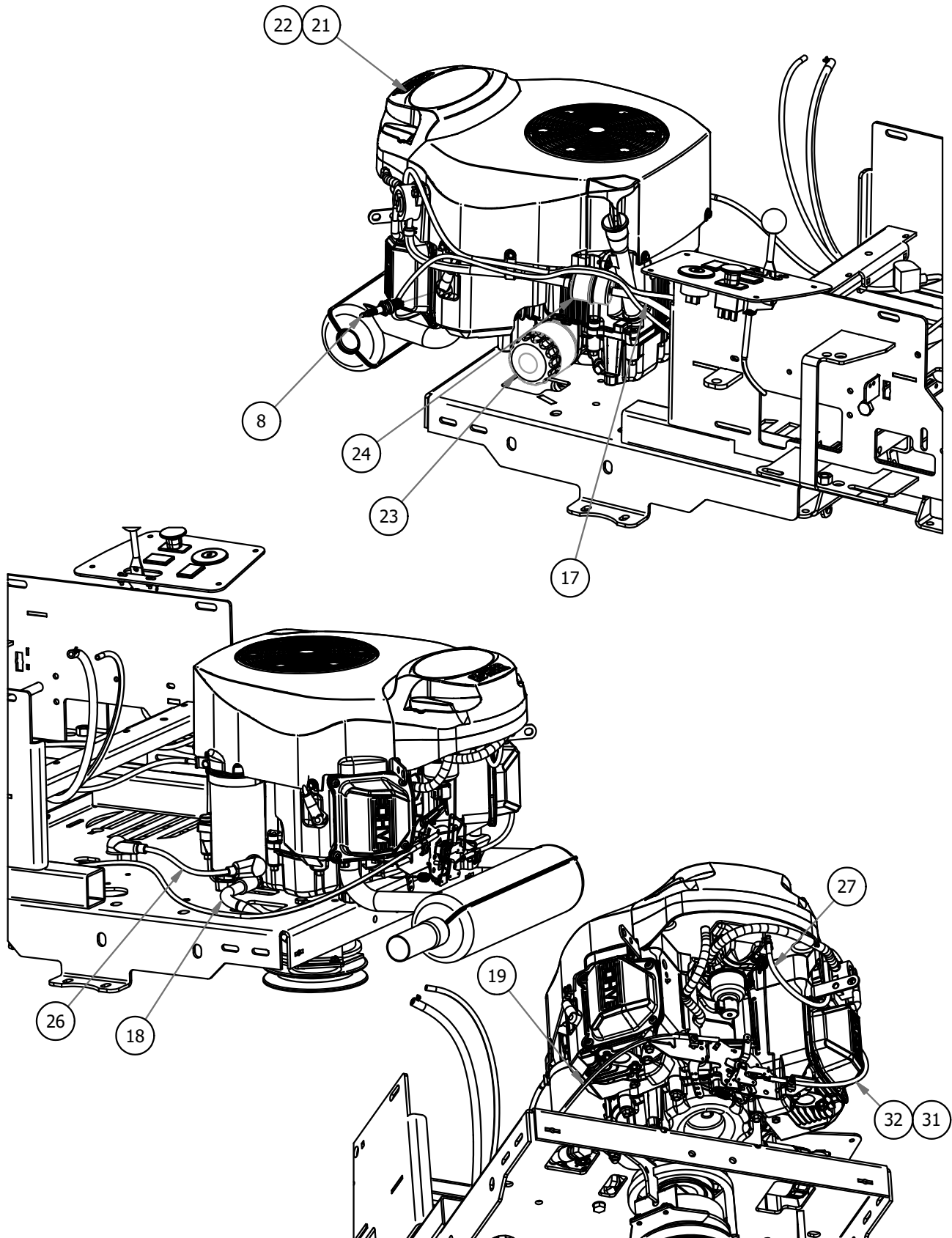



BAD BOY MOWERS

PARTS SECTION: ENGINE-KAWASAKI FR-651V

Parts List				Parts List			
ITEM	QTY	PART NUMBER	DESCRIPTION	ITEM	QTY	PART NUMBER	DESCRIPTION
1	4	013-0075-00	M8-1.25 Zinc Nut	16	1	042-6030-00	1/4" x 1" Key
2	2	013-5041-00	3/8 Nylock Nut	17	1	051-0001-00	15" Fuel Line Assembly
3	1	015-0022-00	726cc Kawasaki Engine-FR651V	18	1	051-5404-00	Oil drain Hose
4	1	015-0052-00	Kawasaki Muffler 1251	19	1	054-8017-00	Choke
5	2	015-2709-00	Exhaust Gasket	20	1	057-5900-00	2017 MZ Clutch Stop
6	2	015-8001-00	Spark Plug - Kawasaki	21	1	063-2097-00	Kawasaki Air Filter
7	1	018-0007-00	7/16"-20 x 3" Hex Bolt Gr. 8	22	1	063-6000-00	Universal Inline Fuel Filter
8	4	018-1075-00	3/8 x 1 1/8 bolt	23	1	063-8017-00	Kawasaki Oil Filter
9	1	018-5321-00	M8x1.20x20MM Hex head bolt	24	1	064-0030-00	Ground Cable
10	2	018-6049-00	3/8" x 1" Hex Bolt	25	1	067-0015-02	MZ Kohler EPA Canister Assembly
11	1	019-6020-00	1/2 Belleville Washer	26	1	070-0055-00	Clutch
12	5	019-8051-00	5/16" Lock Washer	27	1	070-5420-00	2017 MZ/ZT 54"-61" Frame
13	1	030-6029-00	3/8" Set Screw	28	1	070-5810-00	2017 MZ/ZT 42"-48" Frame
14	1	033-2010-00	3-3/4" Motor Pulley	29	1	079-3460-01	2017 MZ Magnum Control Panel Assembly
15	1	041-6400-00	Pump Belt				

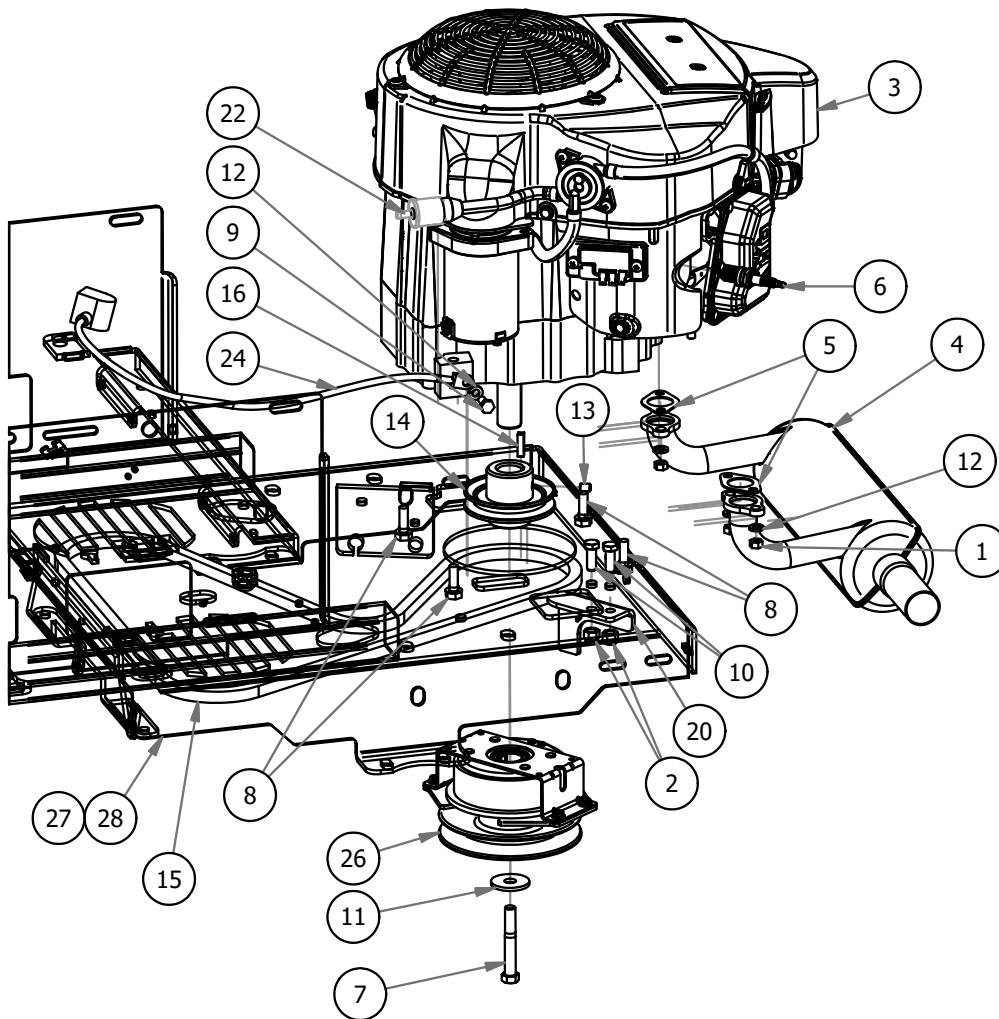



BAD BOY MOWERS

PARTS SECTION: ENGINE-KAWASAKI FR-651V (CONT.)

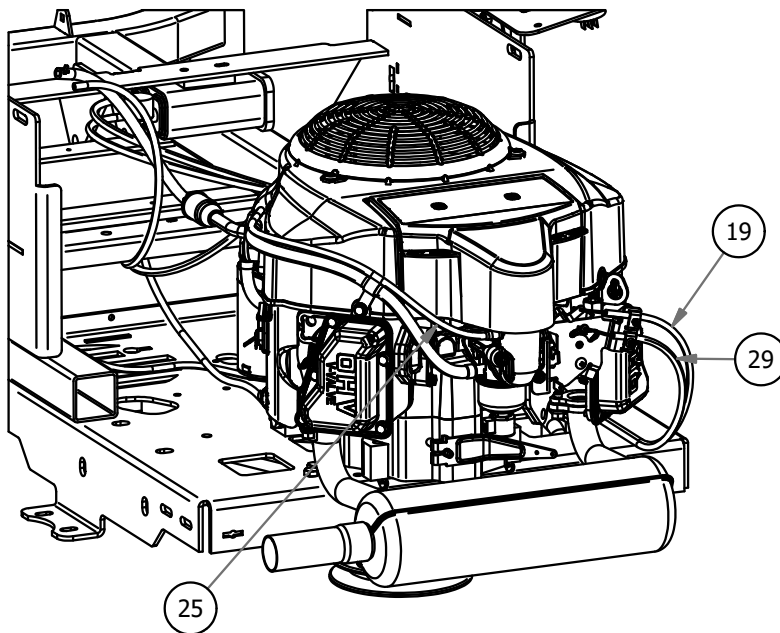
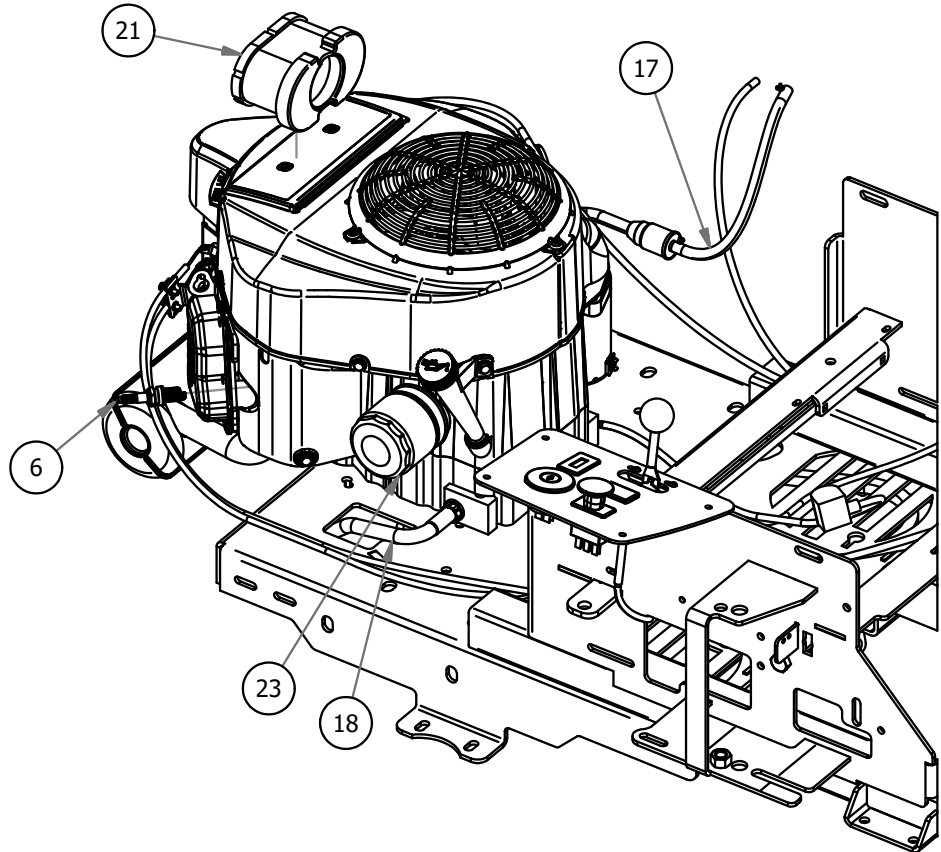



BAD BOY MOWERS

PARTS SECTION: DECALS



091-0313-00
MZ LOGO DECAL FRONT



091-0339-18
BRAKE DECAL

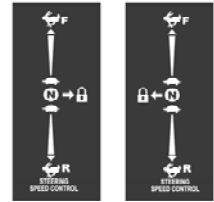

091-0214-00
STEERING SPEED CONTROL DECALS



091-1046-18
MZ FRONT GRILL DECAL



091-0391-00
MZ MAGNUM FRONT GRILL DECAL



091-0301-18
MZ 541cc
REAR COVER DECAL



091-0302-18
MZ 725cc
REAR COVER DECAL



091-0318-18
MZ MAGNUM 725cc
REAR COVER DECAL



091-0319-18
MZ MAGNUM 726cc
REAR COVER DECAL



091-1048-18
42" DECK DECAL



091-0903-18
48" DECK DECAL



091-0904-18
54" DECK DECAL

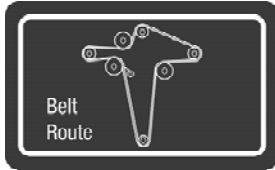

091-0393-00
DECK BELT ROUTE DECAL

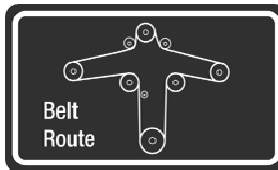

091-3309-00
DECK BELT ROUTE DECAL

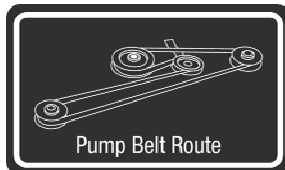

091-3017-00
PUMP BELT ROUTE DECAL



091-3012-00
DANGER DECAL X3

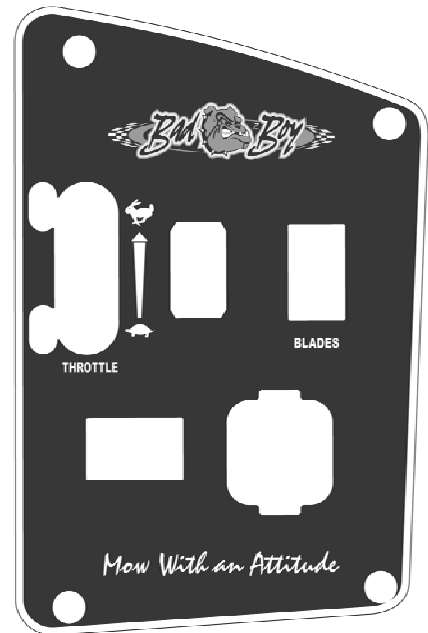

091-0338-18
INSTRUMENT PANEL DECAL

DANGER • STOP BLADE & BACK SLOWLY IF MACHINE STOPS GOING UPHILL • NEVER MOW NEAR PEOPLE • NEVER USE WHEN UNDER THE INFLUENCE OF DRUGS OR ALCOHOL • NEVER CARRY PASSENGERS • SET PARKING BRAKE & REMOVE KEY IF LEAVING MACHINE • AVOID SLIPPERY OR STEEP AREAS • AVOID BLADE UNLESS BLADE & ENGINE ARE STOPPED • USE SAFELY, MACHINE IS NOT A TOY • KNOW LOCATION AND FUNCTION OF CONTROLS • REMOVE POTENTIAL THROWN OBJECTS • KEEP SAFETY DEVICES IN PLACE AND WORKING • LOOK BEHIND MACHINE BEFORE BACKING

DANGER • NEVER MOW UP HILL OVER 5°

DANGER • NEVER MOW UP HILL OVER 10°

DANGER • NEVER MOW SLOPE OVER 15°

CAUTION Shut off engine before refueling. Never fill fuel tank indoors or when engine is hot. Wipe up all spilled fuel before starting engine. Do not smoke while refueling. Do not operate this machine unless you are trained.

CAUTION

• READ OWNER'S MANUAL •

091-3150-00
CAUTION DECAL



2020 LIMITED WARRANTY FOR BAD BOY MZ MOWERS

1. WHAT THIS WARRANTY COVERS, AND FOR HOW LONG:

Bad Boy, Inc. will, at its option, repair or replace, without charge, any part covered by the warranty which is found to be defective in material and/or workmanship for two (2) years or (200) hours* after the date of sale to the original retail purchaser unless the product is used for commercial, industrial, or rental purposes, in which case the Bad Boy MZ mower will carry no warranty, whatsoever.

Belts are warranted for a period of ninety (90) days against materials or workmanship defects.

Seats are warranted for a period of (6) months against material or workmanship defects.

At Bad Boy, Inc.'s request, customer will make the defective part available for inspection by Bad Boy, Inc. and/or return the defective part to Bad Boy, Inc., transportation charges prepaid.

2. WHAT THIS WARRANTY DOES NOT COVER:

A. This warranty does not cover defects caused by depreciation or damage caused by normal wear, accidents, improper maintenance, improper use or abuse of the product, alterations, or failure to follow the instruction contained in the Owner's Manual for operation and maintenance.

B. The customer shall pay any charges for making service calls and/or for transporting the mower to and from the place where the inspection and/or warranty work is performed.

Bad Boy Inc will not be responsible for the pickup and delivery of a machine for warranty purposes.

C. Engines are warranted separately by their respective manufacturer. The available warranties covering this item are furnished with each mower. Bad Boy, Inc does not assume any warranty obligation, liability or modification for this item, which is covered exclusively by the stated warranty of the respective manufacturers.

D. Tires, blades, deck anti-scalping wheels, and dust covers are considered to be consumable wear items and are therefore not warranted.

E. Batteries are warranted for six months (free replacement) from the retail purchase date against materials or workmanship defects. The battery warranty must be obtained through the battery manufacturer.

F. Normal maintenance services such as oil change, cleaning, lubrication, adjustment.

G. Replacement of services, items, such as oil, lubricants, spark plugs, belts, rubber hoses or other items subject to normal service replacement.

3. HOW TO OBTAIN SERVICE UNDER THIS WARRANTY:

A. Warranty service can be arranged by contacting the dealer where you purchased the mower. Proof of the date of purchase may be required to verify warranty coverage. Warranty repairs must be completed by an authorized Bad Boy center.

B. Warranty claims will not be reviewed or paid unless the warranty registration is received by Bad Boy, Inc. within 30 days of the retail purchase date.

C. Warranty claims requiring parts returned will be settled upon return of parts to Bad Boy for inspection.

D. All warranty issues must be handled through an authorized service center or dealership.

4. WARRANTY LIMITATION:

A. **THERE IS NO OTHER EXPRESS WARRANTY. ANY WARRANTY THAT MAY BE IMPLIED FROM THIS PURCHASE INCLUDING MERCHANTABILITY AND FITNESS FOR A PARTICULAR PURPOSE IS HEREBY LIMITED TO THE DURATION OF THIS WARRANTY AND TO THE EXTENT PERMITTED BY LAW ANY AND ALL IMPLIED WARRANTIES ARE EXCLUDED.** Some states do not allow limitations on how long an implied warranty lasts, so the above limitations may not apply to you.

B. **BAD BOY, INC. WILL NOT BE LIABLE FOR ANY INCIDENTAL, CONSEQUENTIAL, OR SPECIAL DAMAGES AND/OR EXPENSES IN CONNECTION WITH THE PURCHASE OR USE OF THE MOWER.** Some states do not allow the exclusion or limitation of incidental or consequential damages, so the above limitation(s) or exclusion(s) may not apply to you.

C. Only the warranty expressed in this limited warranty shall apply and no dealer, distributor, or individual is authorized to amend, modify, or extend this warranty in any way. Accordingly, additional statements such as dealer advertising or presentations, whether oral or written, do not constitute warranties by Bad boy, Inc., and should not be relied on.

D. This warranty extends only to turf equipment operated under normal conditions and properly serviced and maintained. The warranty expressly does not cover (i) any defects, damage or deterioration due to normal use, wear and tear, or exposure; (ii) normal maintenance services such as oil change, cleaning, lubrication, adjustment; (iii) replacement of services, items, such as oil, lubricants, spark plugs, belts, rubber hoses or other items subject to normal service replacement; (iv) damage or defects arising out of or relating to misuse, neglect, alteration, negligence or accident; (v) repair or replacement arising from operation of or use of the turf equipment which is not in accordance with operating instructions as specified in the operator's manual or other operational instructions provided by Bad Boy Inc.; (vi) repair or replacement arising as a result of any operation from turf equipment that has been altered or modified so as to, indetermination of Bad Boy, Inc., adversely affect the operation, performance or durability of the equipment or that has altered, modified or affected the turf equipment so as to change the intended use of the product; (vii) repair or replacement necessitated by use of parts, accessories or supplies, including gasoline, oil or lubricants, incompatible with the turf equipment or other than as recommended in the operator's manual or other operational instructions provided by Bad Boy, Inc.; (viii) repairs or replacements resulting from parts or accessories which have adversely affected the operation, performance or durability of the turf equipment; or (ix) damage or defects due to or arising out of repair of turf equipment by person or persons other than an authorized Bad Boy, Inc., service dealer or the installation of parts other than genuine Bad Boy, Inc., recommended parts.

As a condition to this warranty, customer shall have read the operator's manual and ensured the mower has been registered within 30 days of purchase.

E. This warranty gives you specific legal rights, and you may also have other rights, which vary from state to state.



BAD BOY, INC.

102 INDUSTRIAL DRIVE

BATESVILLE, AR 72501

WWW.BADBOYMOWERS.COM

Technical Support: techsupport@badboymowers.com

Warranty: warranty@badboymowers.com

Parts: partsdept@badboymowers.com

WARRANTY REGISTRATION

Ensure selling dealership has registered mower within
30 days of purchase to validate warranty.

Please record your serial number, date of purchase and dealership information
for your records.

Serial # _____

Date of Purchase _____

Dealer Information _____



**BAD BOY
MOWERS**

www.badboymowers.com

Bad Boy, Inc.

102 Industrial Drive

Batesville, Arkansas 72501