

AIRSTREAM

AN AMERICAN LEGEND

390/395/396

XL

MOTORHOME

2002

OWNERS MANUAL

AIRSTREAM 390/395/396 XL OWNERS MANUAL

2002

INTRODUCTION

The Owners Manual for your new Airstream Motorhome is designed to respond to the most frequent inquiries regarding the operation, function and care of the many systems that make modern motor homing a joy.

Airstream realizes our customers possess varying degrees of expertise in the area of repairing and maintaining the appliances in their motorhome. For this reason, the service and trouble-shooting information found in this manual is directed toward those with average mechanical skills. We also realize you may be more familiar in one area than you are in another. Only you know your capabilities and limitations.

We want you to use this manual, and hope you will find the information contained in it useful, however, should you ever feel you may be "getting in over your head" please see your dealer to have the repairs made.

The operation and care of component parts such as chassis, refrigerator, furnace, water heater and others are briefly explained in this manual. However, you will also find the complete manufacturer's information supplied in a packet included with this manual.

Note: All information, illustrations and specifications contained in the literature are based on the latest product information available at the time of publication approval. Airstream reserves the right to make changes if and when new materials and/or production techniques are developed that can improve the quality of its product, or when material substitutions are necessary due to availability.

Throughout this manual **CAUTION** and  **WARNING** notations are used.

Failure to observe "**CAUTION**" can cause equipment damage if not observed..

Failure to observe “ **WARNING**” can lead to damaged equipment, serious personal injury and/or death if not observed.

Please read and follow all cautions and warnings. If any questions arise contact your dealer or the factory customer service department.

AIRSTREAM 390/395/396 XL OWNERS MANUAL
2002

A. WARRANTY AND SERVICE

Warranty
Warranty Explanation
Service
Reporting Safety Defects
Maintenance Schedule

B. DRIVING

Wide Body Limitations
Loading
Safety, Pre-Travel Check List
Dash controls & Instruments
Trailer Towing & Driving Tips

C. CHASSIS

Chassis-Body Product Definition
Engine
Air Brake System Drainage
Tire/Wheels
Air Conditioner/Heater
Electric Step

D. CAMPING

Camping Safety
Smoke Alarm
Carbon Monoxide Alarm
LP Gas Detector
Overnight Stop
Winter Traveling
Condensation
Extended Stay
Campground Setup
Slide-out Room

E. EXTERIOR

Maintenance
Roof Storage, Ladder
Main Door Locks
Keyless Entry

F. INTERIOR FURNISHINGS AND ACCESSORIES

Lounges & Tables
Fabric Care
Features & Fixtures

G. PLUMBING

LP (Liquid Petroleum) Gas
Water System
Water Pump
City Water Hookup
Storage and Winterizing
Faucets
Drainage System
Toilet

H. ELECTRICAL

12-volt system
Fuses
Monitor Panel
TV Antenna
Satellite and CB Hookups
Solar Panel
110-Volt Power
Generator
Solar Panel, 53 Watt
Search Light

I. APPLIANCES

Air Conditioner
Furnace
Refrigerator
Range/Oven
Microwave Oven
Water Heater
Power Roof Vent

SPECIFICATIONS

Coach Dimensions
Tank Capacities
Chassis Components

AIRSTREAM 390/395/396 XL OWNERS MANUAL 2002

AIRSTREAM INC. LIMITED WARRANTY

WARRANTY COVERAGE

When you buy a new Airstream Motorhome from an authorized Airstream dealer, Airstream, Inc., warrants the motorhome from defects in material and workmanship as follows:

BASIC WARRANTY PERIOD

This warranty is for 30,000 miles (40,000 Kilometers) or two years, whichever comes first, beginning when the vehicle is delivered to the first retail customer or first placed into demonstrator service. This warranty must have started prior to the accumulation of 4,000 miles in order to be valid.

ITEMS COVERED

Any part of the motorhome or any component equipment installed by the factory is covered by the basic warranty *except* the following items, which are *not covered*:

- House Batteries
- Automotive Chassis
- Generator

The above items will be handled by their respective service points and according to their written policy. This limited warranty does not include failure caused by accident, abuse, normal wears, overload or any cause not attributable to a defect in original material or workmanship of the motorhome or component equipment as installed by the factory.

LIMITATION OF IMPLIED WARRANTIES

All warranties of merchantability and fitness for a particular purpose, whether written or oral, express or implied, shall extend only for a period of two years from the date of original purchase, or 30,000 miles, whichever comes first. There are no other warranties, which extend beyond those described on the face hereof and which expressly excludes conditions resulting, from normal wear, accident, abuse, exposure or overload. Some states do not allow limitation on how long an implied warranty lasts, so the above limitations may not apply to you.

AIRSTREAM'S RESPONSIBILITY

The basic **Airstream Limited Warranty** applies for a period of two years from the date of original purchase or 30,000 miles, whichever comes first, and the application date of all warranties is that indicated on the owner's identification card. Defects in items covered under this Warranty will be corrected without cost upon the return, at the owner's expense, of the motorhome or defective part to an authorized Airstream dealer.

AIRSTREAM 390/395/396 XL OWNERS MANUAL

2002

CARE AND MAINTENANCE

This warranty covers only defective material and/or workmanship; adjustments are made at the factory prior to shipment, and rechecked by the dealer prior to delivery to the customer. Adjustments thereafter become a customer responsibility.

The owner is also responsible for following all recommendations, instructions and precautions contained in the Airstream Motorhome Owner's Manual and the individual manuals furnished by the chassis, appliance and other manufacturers.

INSTALLATIONS NOT COVERED

Airstream Inc. does not accept any responsibility in connection with any of its motorhomes for additional equipment or accessories installed at any dealership or other place of business, or by any other party. Such installation of equipment or accessories by any other party will not be covered by the terms of this warranty.

IF REPAIRS ARE NEEDED

If your motorhome needs repairs under the terms of the basic Airstream Limited Warranty, you should:

1. Take your motorhome to your selling dealer or other Authorized Airstream Dealer.
2. If the dealer is incapable of making the repair, request that he contact the Service Administration Department at Airstream, Inc., for technical assistance.
3. If repairs are still not made, the customer should contact:

AIRSTREAM, INC.
419 W. Pike Street - P.O. Box 629
Jackson Center, Ohio 45334-0629
Attention: Owner Relations Department

Furnish the following information:

- The complete serial number of the motorhome
 - Mileage
 - Date of original purchase
 - Selling dealer
 - Nature of service problem and steps or service, which have been performed. (The owner may be directed to another dealer at the owner's expense.)
4. If, after taking the above steps, repairs are still not complete, the Airstream owner may request the motorhome be allowed to be brought to the Factory Service Center at the owner's expense.

DEALER REPRESENTATION EXCLUDED

The full extent of the basic **Airstream Limited Warranty** is set forth-in detail in the folder, and in the explanation of the basic **Airstream Limited Warranty** covered in the Airstream Motorhome Owner's Manual. Airstream Inc. will not be responsible for additional representations or implied warranties made by any of its dealers to the extent those representations are not a part of, or are contrary to, the terms and conditions of the basic **Airstream Limited Warranty**.

AIRSTREAM 390/395/396 XL OWNERS MANUAL

2002

CONSEQUENTIAL AND INCIDENTAL DAMAGES

Airstream, Inc., will not be responsible for any consequential or incidental expenses or damages resulting from a defect. Incidental expenses include, but are not limited to: travel expenses, gasoline, oil, lodging, meals, telephone tolls, and loss of work and loss of use of the motorhome. Some examples of consequential damages would be: stained curtains due to rain leaks or delaminated floor caused by a plumbing leak. *Some states do not allow the exclusion or limitation of incidental or consequential damages, so the above limitation or exclusion may not apply to you.*

WARRANTY TRANSFER

The basic **Airstream Limited Warranty** is transferable to subsequent owners for the duration of the warranty period. Warranty transfer application forms are available from your dealer or the Airstream Inc. Service Administration Department.

CHANGES IN DESIGN

Airstream Inc. reserves the right to make changes in design and improvements upon its product without imposing my obligation upon itself to install the same upon its products theretofore manufactured.

This warranty gives you specific legal rights, and you may also have other rights, which vary from state to state.

Thor Industries
Airstream Inc.
419 West Pike Street
Jackson Center, Ohio 45334
937-596-6111

AIRSTREAM 390/395/396 XL OWNERS MANUAL

2002

WARRANTY EXPLANATION

Along with your new Airstream motorhome you have purchased the Airstream Limited Warranty. Read your Limited Warranty carefully. It contains the entire agreement with respect to Airstream's obligation on the Limited Warranty on your new vehicle. The terms of the Limited Warranty, and only those terms, will define Airstream's responsibility. When you receive your Limited Warranty file it for safekeeping.

Upon proof of purchase date to any Airstream Dealer Service Center, defects in materials or workmanship will be repaired or replaced without cost to the owner for a period of twenty four (24) months from the original purchase date, or 30,000 miles, whichever occurs first. Written warranties of some component manufacturers of the motorhome will be honored by Airstream for the duration on that manufacturer's warranty.

Items such as motorhome chassis, engine, tires, batteries and generator are serviced by their respective manufacturers and will be handled by their service centers according to the terms of their written policy. Any warranty forms from these manufacturers should be completed promptly, preferably at time of purchase.

Your motorhome chassis is pre-checked by its manufacturer before delivery to Airstream. All service to the chassis must be performed by the chassis manufacturer according to the manufacturer's warranty and service policies. Literature is supplied with each Airstream motorhome, which gives important information concerning its warranty coverage; however, the Airstream Limited Warranty covers the chassis heater, defrosters, windshield wiper blade, motor, washer, LP gas bottle and gas regulator.

Paint and appearance items, which show imperfections, should be brought to the attention of your dealer at the time of delivery and during pre-delivery inspection. Normal deterioration by use and exposure is not covered by the Airstream Limited Warranty.

Damage to enamel or porcelain surfaces resulting from abrasion, collision or impact, and broken window glass are not covered by the Airstream Limited Warranty.

The Airstream Limited Warranty Excludes:

Normal Wear:

Items such as water purifier packs, curtains, upholstery, floor coverings, window, door and vent seals may show wear within the one year Limited Warranty period depending upon the amount of usage, weather and atmospheric conditions.

Accident

Damage caused by accident is usually visible, and we strongly urge our dealers and customers to inspect the motorhome upon delivery for any damage caused by accident while being delivered to the dealer, or while it is on the dealer's lot. Damage of this nature becomes the dealer's or your responsibility upon acceptance of the motorhome. GLASS BREAKAGE, whether obviously struck or mysterious, is always accidental and covered by most insurance policies.

Abuse

Lack of customer care and/or improper maintenance, including failure to comply with the terms of the Owner's Manual, or failure to heed proper vehicle operation shown by the dash instruments is not covered by warranty.

AIRSTREAM 390/395/396 XL OWNERS MANUAL

2002

Exposure

Deterioration by sunlight is possible to such items as tires, curtains or upholstery. Steel or metal surfaces are subject to the elements, causing rust and corrosion, which is normal, and beyond the control and responsibility of Airstream.

Overload

Overload Damage due to loading beyond capacity or to cause improper balance is not covered by the Airstream Limited Warranty. The Airstream motorhome body is engineered to properly handle any normal load. There are limits to the amount of load that can be safely transported depending upon speed and road conditions. If these limits have been exceeded the Airstream Limited Warranty will not cover resulting damage. For additional information on the load capacity of your motorhome consult your Owner's Manual or gross vehicle weight rating plate. Each motorhome is aligned during the last quality inspection. These tolerances will only change if the motorhome is subjected to abuse, such as dropping off a sharp berm, striking a curb, or hitting a deep hole in the road. Such damage would be considered as resulting from an accident which risks are not covered under the warranty. Abnormal tire wear and/or wheel alignment resulting from such damage is not covered under the terms of the warranty.

SERVICE

The Airstream Silver Key Delivery Program is an exclusive Airstream program. Before leaving the factory each and every vital part of the motorhome is tested for performance. Each test is signed and certified by an inspector. After the motorhome arrives on your dealer's lot all of these vital parts and systems are again tested. When you take delivery of your new motorhome you will receive a complete checkout.

Please contact your dealer if you need service. Major service under your Airstream Limited Warranty is available through our nationwide network of Airstream Dealer Service Centers. An up-to-date list of Dealer Service Centers has been provided with your new motorhome. This list is current as of the date of publication.

Occasionally dealerships change, or new dealers are added who may not appear on this list. For this reason, it is suggested that you contact your local dealer from time to time and bring your list up to date. He can also provide you with additional copies if you need them.

ALL CENTERS OPERATE ON AN APPOINTMENT BASIS FOR THE UTMOST EFFICIENCY.

When you require service from the Airstream Factory Service Center, or a Certified Dealer Service Center, please contact the service manager for an appointment, and kindly inform him if you are unable to keep the appointment date or wish to change it.

Service may be arranged at the Factory Service Center by contacting the Service Coordinator at

Airstream Factory
Service Center
419 W. Pike Street P.O. Box 629
Jackson Center, Ohio 45334-0629
Phone: 937-596-6111
Fax: 937-596-6802

AIRSTREAM 390/395/396 XL OWNERS MANUAL

2002

You Should Also be Aware of the Following:

Airstream is not responsible for any consequential or incidental damages incurred as a result of any defect. Consequential damages include, but are not limited to, travel expenses, gasoline, oil, lodging, meals, telephone tolls, loss of work and loss of use of the motorhome.

In the event of a defect, the owner must take all reasonable corrective action to lessen the damages, which might result from such defect. Airstream will not be responsible for damages, which could have been avoided.

Airstream's responsibility is defined solely by the Airstream Limited Warranty. Airstream is not responsible for or bound by representations or warranties made by any of its dealers.

Your Airstream Limited Warranty is transferable to subsequent owners of the motorhome, but only for the duration of the warranty period. Warranty transfer application forms are available from your dealer or the Airstream factory.

REPORTING SAFETY DEFECTS

If you believe that your vehicle has a defect, which could cause a crash or could cause injury or death, you should immediately inform the National Highway Traffic Safety Administration (NHTSA) in addition to notifying Airstream, Inc.

If NHTSA receives similar complaints, it may open an investigation, and if it finds that a safety defect exists in a group of vehicles, it may order a recall and remedy campaign. However, NHTSA cannot become involved in individual problems between you, your dealer, or Airstream, Inc.

To contact NHTSA you may either call the Auto Safety Hotline toll-free at 1-800-424-9393 (or 366-0123 in Washington, D.C. area) or write to: NHTSA, U.S. Department of Transportation, Washington, D.C. 20590. You can also obtain other information about motor vehicle safety from the Hotline.

AIRSTREAM 390/395/396 XL OWNERS MANUAL 2002

MAINTENANCE SCHEDULE



Warning: FAILURE TO MAINTAIN YOUR COACH CAN CAUSE PREMATURE AND UNEXPECTED PARTS BREAKAGE AND/OR ERRATIC OPERATION THAT MAY BE HAZARDOUS.

Note: See Freightliner and appliance manufacturer's literature for further information.

EVERY 1,000 MILES OR 60 DAYS

Escape Window	Check operation of latches and upper hinge.
Battery (Lead acid)	Check water level.
Smoke Alarm	Test and replace battery as required.
Tires	Check tire pressure (105 psi max.) See tire warnings on page C-4.
GFI Circuit Breaker	Test and record.

EVERY 5,000 MILES OR 90 DAYS

Exterior Door locks	Lubricate with dry graphite
Exterior Hinges	Lubricate with light household oil
LPG Regulator	Check bottom vent for obstructions
Main Door Striker Pocket	Coat with paraffin.
Range Exhaust Hood	Clean fan blades and wash filter.
Roof Vent Elevator Screws	Lubricate with light household oil
Main Door Step	Check and lubricate moving parts.

EVERY 10, 000 MILES OR 6 MONTHS

Exterior	Clean and wax.
Hitch	Check bolts and welds. (60 Ft. Lbs.)

EVERY YEAR or 12,000 miles

Battery	Clean, neutralize and coat terminals with petroleum jelly.
LP Tank	Have purged by an LP supplier.
Seams	Check and reseal exterior seams, windows, lights and vents if necessary. Reseal with Bostik urethane sealant or equivalent as needed.

AIRSTREAM 390/395/396 XL OWNERS MANUAL 2002

DRIVING

WIDE BODY LIMITATIONS

Vehicles with overall body width greater than 96" are known as "wide bodies. Wide body vehicles are restricted to use on main highways in certain states. A vast majority of states allow 102" body width on all highways, but wide body width is not allowed on all federal highways in the United States. Your dealer may be able to furnish more specific information. If you are concerned about vehicle width, we invite you to consider other fine Thor vehicles offered in the standard 96" width.

LOADING

Below is a sample of the weight information chart provided in all Airstream vehicles. This information can be found in your vehicle on the back of the first wardrobe door on the curbside of the vehicle about 60" up from the floor or in one of the galley overhead lockers.

MOTORHOME WEIGHT INFORMATION

VIN OR SERIAL NUMBER

GVWR (GROSS VEHICLE WEIGHT RATING) IS THE MAXIMUM PERMISSIBLE WEIGHT OF THIS FULLY LOADED MOTORHOME.

UVW (UNLOADED VEHICLE WEIGHT) IS THE WEIGHT OF THIS MOTORHOME AS MANUFACTURED AT THE FACTORY WITH FULL FUEL, ENGINE OIL AND COOLANTS.

SCWR (SLEEPING CAPACITY WEIGHT RATING) IS THE MANUFACTURER'S DESIGNATED NUMBER OF SLEEPING POSITIONS MULTIPLIED BY 154 POUNDS (70 KILOGRAMS).

CCC (CARGO CARRYING CAPACITY) IS EQUAL TO GVWR MINUS EACH OF THE FOLLOWING: UVW, FULL FRESH (POTABLE) WATER WEIGHT (INCLUDING WATER HEATER), FULL LP GAS WEIGHT AND SCWR.

CARGO CARRYING CAPACITY (CCC) COMPUTATION

	POUNDS	KILOGRAMS
GVWR		
MINUS UVW		
MINUS FRESH WATER WEIGHT OF GALLONS @ 8.3 LB/GAL		
MINUS LP GAS WEIGHT OF GALLONS @ 4.5 LB/GAL		
MINUS SCWR OF PERSONS @ 154 LB/PERSON		
= CCC FOR THIS MOTORHOME*		

*DEALER INSTALLED EQUIPMENT AND TOWED VEHICLE TONGUE WEIGHT WILL REDUCE CCC

CONSULT OWNER MANUAL(S) FOR SPECIFIC WEIGHING INSTRUCTIONS AND TOWING GUIDELINES. CD-130

The GROSS COMBINATION WEIGHT RATING on the 390/395/396 motorhome is 36,000 pounds.



WARNING - Do not exceed the hitch capacity of 500 lbs. load (Tongue Weight) and 5000 lb. tow.

The motorhomes have large fluid tanks and lots of storage areas. It gives you great flexibility in loading. With flexibility comes responsibility. If you want to load down all the storage compartments the amount of fluids will have to be reduced. Distribute your additional cargo as evenly as possible with the heaviest objects located as low as possible.

Do you really want to carry 750 pounds of water to a RV park 1,000 miles away and then hook up to a city water supply? Even if you're going to the "boondocks" you can usually fill your water tank shortly before entering the area. Just reducing your load by 10 gallons of water lets you carry an awful lot of fishing and camping gear.

AIRSTREAM 390/395/396 XL OWNERS MANUAL

2002

WEIGHING

The UVW, unloaded vehicle weight, given in the chart above is the weight of the motorhome with the options as ordered, and installed at the factory. To determine the actual weight of your vehicle with personal cargo, water and LP, it must be weighed on scales. The most common are those used by states to weigh trucks used along the highway. In rural areas grain elevators are a good source and another would be a gravel pit. If you have trouble locating scales, a call to your State Highway Patrol will usually find them very cooperative in assisting you.



WARNING: Do not exceed the Gross Axle Weight Ratings or the Gross Vehicle Weight Rating when loading your vehicle.

SAFETY CHECK LIST

Your Airstream motorhome should be given a thorough safety check before a trip. Regular use of the following list will provide safe operation of your motorhome and will help you spot any malfunctioning equipment and correct the problem as soon as possible. The list is to help you and may not be all-inclusive.

Failure to heed many of the following items may cause damage to the vehicle or personal injury.

EXTERIOR CHECK LIST (BEFORE ENTERING VEHICLE)

1. Check condition of tires for proper inflation. **See tire warnings on page C-4.**
2. Turn off LPG valve on LPG tank.
3. Check that sewer connection, all external compartments and filler openings are properly stowed or closed and/or locked.
4. Check that items stored on exterior of vehicle are securely tied down.
5. Would any items stored on exterior of vehicle present a clearance problem?
6. Lower and secure awnings/TV antenna.

INTERIOR CHECK LIST (BEFORE DRIVING OFF)

1. It is important that the main door and cab door be completely closed and locked during travel. As an added precaution we recommend the dead bolt also be locked on the main door.
2. Turn off living area water pump.
3. Check that refrigerator door is fastened.
4. Check that nothing heavy is stored in overhead or high cabinets that could fall out and cause injury. Heavy items should be stored in low cabinets.
5. Stow folding and pedestal tables.
6. Check that counter tops, range top, credenza tops and shelves are clear of even small items that could become projectiles in an accident.
7. Do not cook while under way. Hot food or liquid could scald due to a sudden stop or accident.
8. Check that any internal stowage is securely held in place
9. Check that lights and switches are set in positions safe for travel.
10. Adjust the driver's seat so that you can easily reach and operate all controls. Make sure seat is locked in position. Do not adjust driver's seat swivel or fore and aft mechanism while vehicle is moving. The seat could move unexpectedly causing loss of control.
11. Check that front passenger's seat is locked in position - both fore and aft adjustment and swivel mechanism.
12. Check rear view mirror adjustment.
13. Fasten lap belts.
14. Check that step light goes out and that electric step has retracted.

AIRSTREAM 390/395/396 XL OWNERS MANUAL

2002

SAFETY SEAT BELTS

In the forward driver's area of the motorhome, safety seat belts are provided for the use of the driver and the right front passenger. Safety belts are available for other seats. It is strongly recommended that all occupants remain seated with their safety belts firmly attached while the motorhome is in motion. The driver should adjust his seat so that he is able to reach all controls easily with the belt on, especially able to use all the travel on the foot brake. The belt should be placed as low as possible around the hips to prevent sliding out from under them in case of accident. This places the load of the body on the strong hipbone structure instead of around the soft abdominal area. Two people should never try to use the same seat belt.



WARNING: Children must be secured in a Federally Approved Child Restraint Device. Failure to use proper restraints can result in severe or fatal injuries in case of accidents.

Child restraint devices are designed to be secured with lap or lap/shoulder belts. All instructions supplied by the restraint manufacturer must be followed. Statistics have shown children are safer when properly restrained in a rear seating position than in a front seating position.

Often the children traveling in motorhomes are grandchildren. There are times when our love for grandchildren makes us hesitate to properly supervise their actions. Don't hesitate when it comes to their safety. Make sure they are properly restrained.

CHILDREN HAVE LOVED ONES TOO.

IF YOU WON'T BUCKLE UP FOR YOURSELF, BUCKLE UP FOR THEM.

AIRSTREAM 390/395/396 XL OWNERS MANUAL

2002

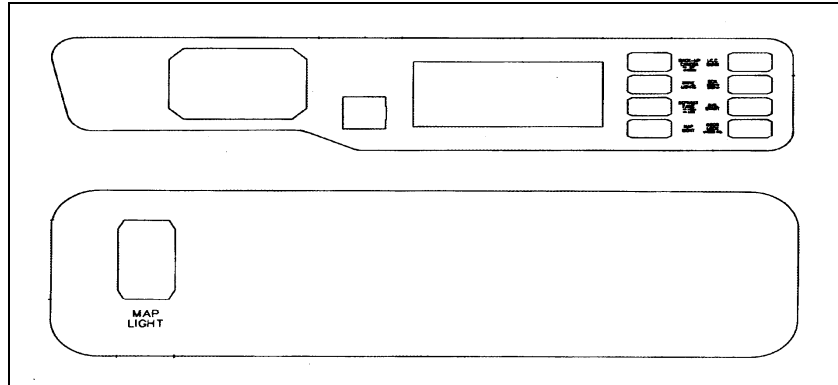

NOTE: Switches will vary according to options on vehicle.

AIRSTREAM DASH CONTROLS

Most automotive gauges and controls are standard instruments provided by the chassis manufacturer. Their function and use is described in your Drivers Manual. The exception on automotive controls is the heater/air conditioner. Operating- instructions on these components can be found in the chassis section of this manual.

DASH SWITCHES:

- **Aisle Lights** - The low aisle lights will allow passengers to converse without using overhead lights that could be bothersome to a driver at night.
- **Docking Lights RS** - The docking lights illuminate the area at the side of the motorhome and are intended for use when parking in a campground at night.
- **Air Dump Switch** – Down on the side of the armrest is a switch (valve) that is part of the Freightliner air suspension. There are two advantages to dumping the air, first it lowers the vehicle and makes the first step height easier to use, and second, without air in the suspension you may find it unnecessary to deploy the stabilizing/leveling jacks.

Armrest Switches

- **ICC Blink** - With this switch it is possible to blink the clearance lights on the motorhome. It's most commonly used as a way of indicating your thanks for a courtesy shown to you by another driver.
- **Rear Camera** - The rear view-monitoring camera has two positions. One will show the rear bumper and operating the switch tilts the camera to view further back.
- **Driving Lights** - To operate the driving lights the regular headlights must be turned on first.
- **Defrost Fans** - In cool, damp weather these fans really help to clear the large windshields. This switch turns them on and off and each fan has its own switch to operate the oscillating feature.
- **Door Lock** - The main door deadbolt can be locked or unlocked electronically from the drivers seat. Remember to hide an extra door key on the exterior in case of unexpected battery failure. The manual knob is located by the passenger seat and is for interior use only.
- **Auxiliary Start** - The auxiliary start switch is intended to be used if the engine battery becomes too discharged to turn the engine over. To operate, hold the switch in the start position, and then use the ignition switch in a normal fashion. Operating the auxiliary start switch closes the points on a large solenoid, tying all three-vehicle batteries together for increased starting power.

AIRSTREAM 390/395/396 XL OWNERS MANUAL

2002

- **Generator Switch** - The remote generator switch on the dash allows the driver to start or stop the Generator without leaving the driver's seat. It should be noted a built-in time delay allows the generator to reach full operating speed before 120 volt current is provided to the coach.
- **Mirror** - Move center switch to R or L. The four perimeter switches will then move the right or left mirror in the direction indicated. The paddle type switch marked heat is for defrosting the mirrors. (Hopefully you won't need this unless you're a skier).
- **Map Lights** – Lights mounted above both cab seats to aid in reading. Switches are mounted in both armrests.

POWER SEAT CONTROLS

Besides the normal power seat switch there are two additional finger levers. One allows the seat to recline and the other will allow the seat to rotate.



WARNING: Never adjust drivers seat while vehicle is in motion.

CAUTION: Revolving the power seat completely around will pull the wiring apart. The seats should only be swiveled toward the center of the vehicle. If the wires are loosened following the color code can reconnect them: Red-to-red, green-to-green, etc. On some models the wires will be on a plug that can be reattached.

TRAILER TOWING AND DRIVING TIPS

This vehicle is designed and intended to be used primarily as a load-carrying recreational vehicle, towing a trailer will affect handling, durability and economy. Maximum safety and satisfaction depends upon proper use of correct equipment and avoiding overloads and other abusive operation.

CAUTION: The maximum loaded trailer weight that you can pull with your vehicle is 5,000 lbs. Vehicles should be properly equipped for towing trailers. Information on trailer hauling capabilities and special equipment required may be obtained from your Airstream dealer.

CAUTION: The Gross Combined Weight Rating is the total allowable weight of the motorhome combined with the weight of the vehicle or trailer being towed. Do not exceed this weight whenever you are towing behind your motorhome. The GCWR is 34,410 lbs.

To assist in attaining good handling of the vehicle/trailer combination it is important that the trailer tongue load be maintained at approximately 10% of the loaded trailer weight, but not to exceed 500 lbs. Tongue loads can be adjusted by proper distribution of the load in the trailer, and can be checked by weighing separately the loaded trailer and then the tongue. When towing trailers, tires should be inflated to the highest pressures shown on the information plate attached to the driver's doorjamb or dash of your motorhome. The allowable passenger and cargo load (GVW) of this vehicle is reduced by an amount equal to the trailer tongue load on the trailer hitch.

AIRSTREAM 390/395/396 XL OWNERS MANUAL
2002



Warning: The towing vehicle's braking system is rated for operation at GVWR (GROSS VEHICLE WEIGHT RATING), NOT at the GCWR (GROSS COMBINED WEIGHT RATING). A separate functioning brake system is required for any towed vehicles or trailers weighing more than 1000 lbs. (450 kg) when fully loaded. NEVER exceed the GVWR (GROSS VEHICLE WEIGHT RATING), or the GAWR (GROSS AXLE WEIGHT RATING) specified on a motorhome certification label. Also NEVER exceed the weight ratings of trailer hitch installed on a motorhome. Failure to heed any part of this warning could result in loss of control of the motorhome and towed vehicle or trailer and may cause an accident and serious injury. For specified towed vehicle braking requirements, consult the chassis owner's manual that comes with this vehicle.

CAUTION: If your Freightliner chassis requires towing please refer to their manual for directions. They may be called at 1-864-487-1700.

See fire warnings on page C-4.

AIRSTREAM 390/395/396 XL OWNERS MANUAL

2002

CHASSIS

The Airstream motorhome is built on a Freightliner chassis. Operation of the engine and other related components are discussed in the Freightliner Owners and Drivers Manual supplied with each coach.

If repairs are needed it can be difficult to determine which parts of the chassis are warranted by Freightliner, and which are Airstream's responsibility. The following list shows the major components of the chassis and the company responsible for their servicing.

FREIGHTLINER X LINE CHASSIS

Engine	Air Conditioner Compressor
Transmission	Shocks
Brakes	Automotive Fuse Panels
Steering Assembly	Parking Brake
Front Spindle, Bearings	Fuel Tank
Alternator	Cruise Control
Turn Signals	Wheels
Drive Axle and Hubs	

AIRSTREAM

Auxiliary Heater	Windshield Wipers
Dash Air Conditioner/Heater	Isolator

The above list covers almost all of the chassis components. If you need further clarification or information your dealer should be contacted with the details.

ENGINE ACCESS

Although most engine functions and maintenance can be preformed from outside the coach, occasionally "top" engine service will be required.

To make this servicing easier the bed top can be raised with the assistance of gas props. Once the bed top is raised the engine cover can be unlatched and raised to expose the engine.

 **WARNING** - The lifting and supporting strength of the gas props vary according to temperature. Props that support the bed top when hot may let the bed close rapidly when cold.

AIR BRAKE SYSTEM DRAINAGE

Your motorhome is equipped with an air brake system. When air is compressed some liquid is forced out and collects in the bottom of the air tanks and must be drained.

Three drain valves are on your brake system. The valves can be opened for drainage by pulling on the looped cables in your front wheel wells on each side. See your Freightliner operator's manual under Pre-trip Inspection for directions.

AIRSTREAM 390/395/396 XL OWNERS MANUAL

2002

TIRE SUPPORT (Leveling)

Since motorhomes may sit for long periods of time it is important to properly support the tires if blocks are used for leveling.

The Michelin Technical Group provides the following information.

Caution: Extreme care must be taken to ensure that the tires are fully supported when using blocks to level motorhomes and/or RV's. The load on the tire should be evenly distributed on the block and in the case of duals, evenly distributed on blocks for both tires. If not properly done, the steel cables in the sidewall of the tires may be damaged and could lead to premature fatigue of the sidewall. **See tire warnings on page C-4**

The **CORRECT** methods are shown in Figure 1. Please note that the blocks are wider than the tread and longer than the tire's footprint. This provides maximum support to the tires and assures that the load is evenly distributed throughout the tire's footprint area.

FIGURE I

CORRECT

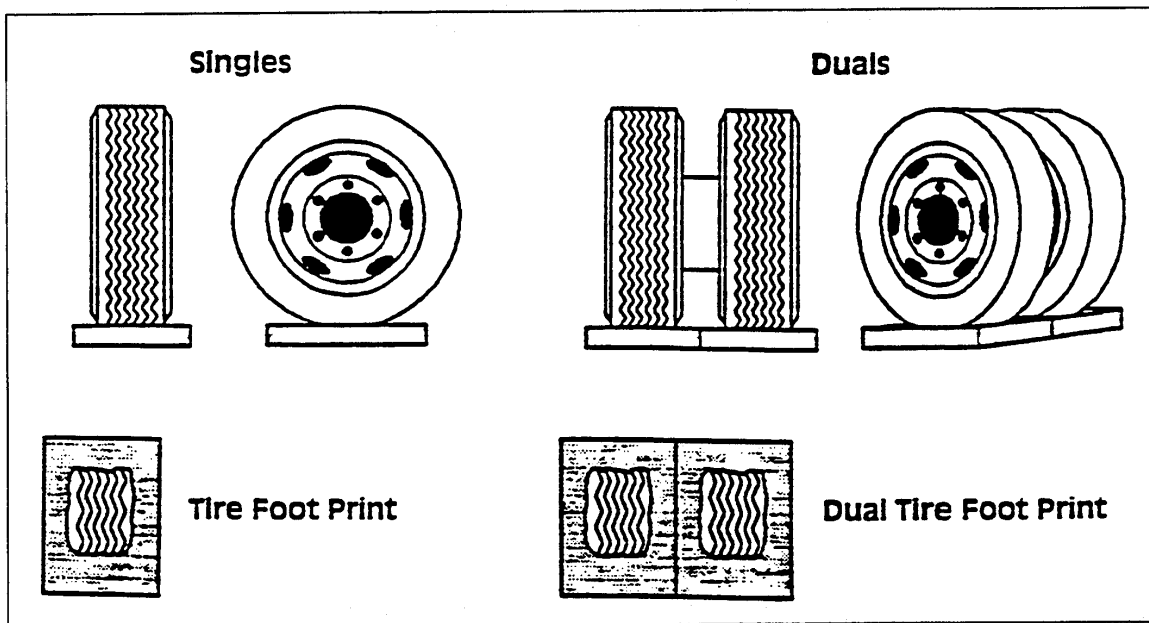

AIRSTREAM 390/395/396 XL OWNERS MANUAL
2002

INCORRECT

One tire or a portion of one tire is supporting the full load.

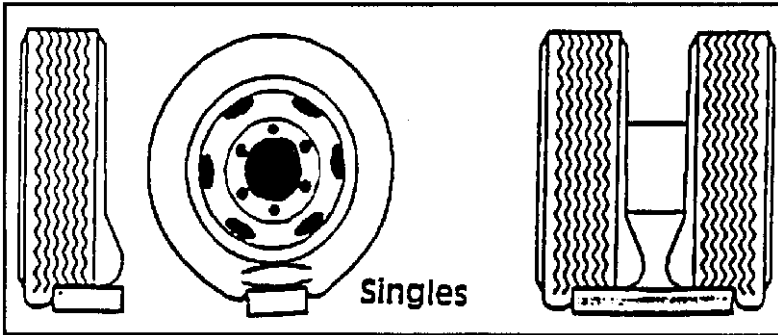
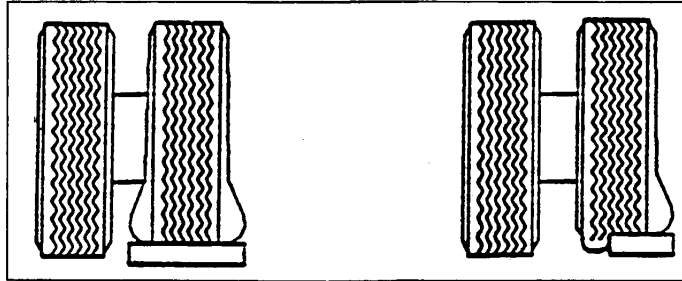

Portion of two tires are supporting the full load.

CAUTION: Tires incorrectly supported, as shown above, may be damaged which could lead to casing failure resulting in serious injury or property damage. If, on previous occasions, the tires have been incorrectly supported, a hidden damage may be present. Please contact your local Michelin dealer and request an inspection and a determination of possible damage. **See tire warnings on page C-4**

AIRSTREAM 390/395/396 XL OWNERS MANUAL

2002

TIRE INFLATION INFORMATION

Your vehicle is equipped with a tire that is an all-steel radial. All-steel radial tires utilize steel cords in the sidewalls, and also require increased inflation pressures up to 105 PSI. As such, they cannot be treated like normal light truck tires. Personnel trained, supervised and equipped according to Federal Occupational Safety and Health Administration (OSHA) regulations must perform tire service, including adjusting tire pressure. For example, during a procedure involving tire inflation, the technician or individual must utilize a remote inflation device, and insure that all persons are clear of the trajectory area.

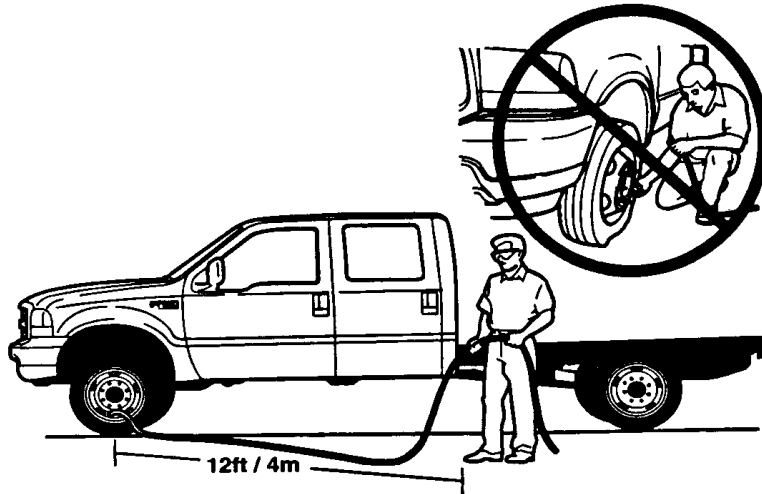

⚠ Warning: An inflated tire and rim can be very dangerous if improperly used, service or maintained. To avoid serious injury, never attempt to re-inflate a tire which has been run flat or seriously under inflated without first removing a tire from the wheel assembly for inspection. Do not attempt to add air to tires or replace tires or wheels without first taking precautions to protect persons and property.

Michelin provides a Recreational Vehicle Tire Guide with each Freightliner chassis that is passed along to you in the Airstream Owner's Packet. Please take the time to read it as it has information on the loading, weighing, and inflation of your RV and its tires.

AIRSTREAM 390/395/396 XL OWNERS MANUAL
2002

DASH AIR CONDITIONER/HEATER

Specific Climate Systems Inc.
1200 West Risinger Road
Fort Worth, Texas
Technical Assistance: 1-800-275-7524

OPERATION

The dash heater control is very similar to many automobiles

The center rotary switch marked "cold-hot" controls the amount of hot water flowing through the heater core. When the maximum air conditioner is engaged, inside air is circulated through the evaporator to obtain the utmost in cooling. The two positions marked vent and norm draw outside air through the evaporator.

SERVICE

SCS has requested you to call them on the 800 number listed above should you experience any service problems. They are usually able to help get any repairs needed at an air conditioner repair facility close to your location.

The following pages include wiring diagrams and vacuum line diagrams.

AIRSTREAM 390/395/396 XL OWNERS MANUAL
2002

SCS/Frigette Motorhome HVAC Systems

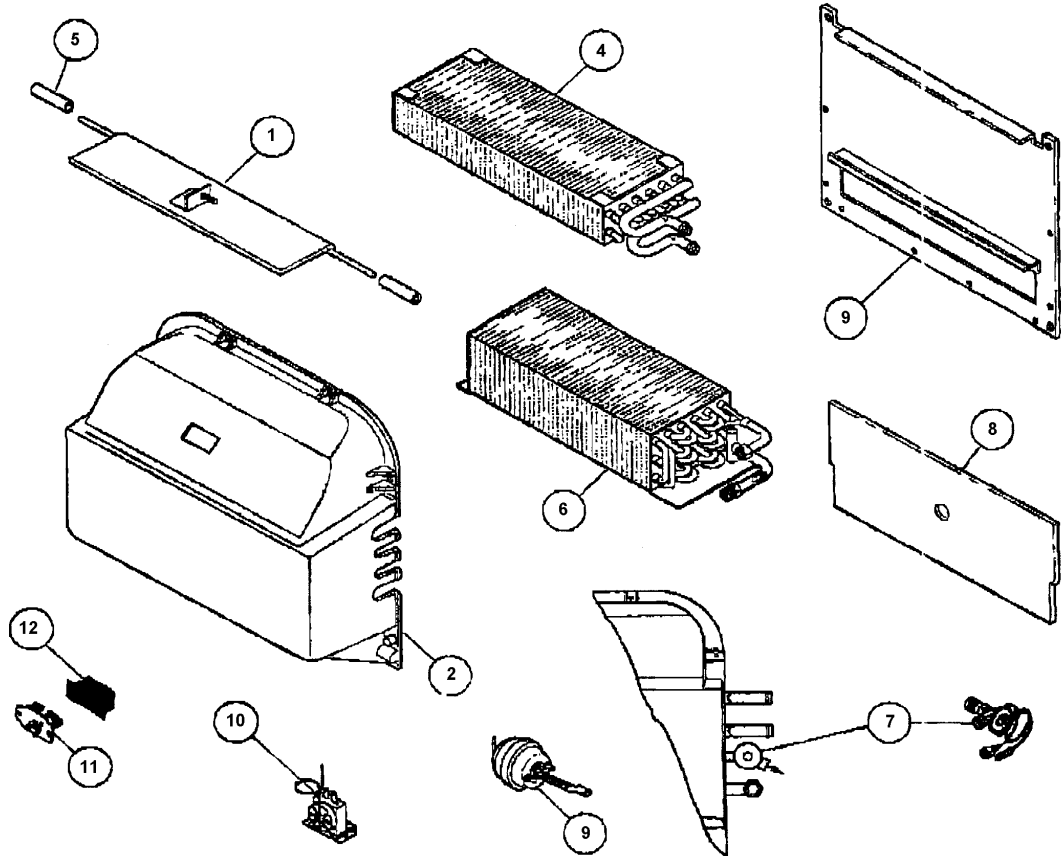

- 1. 087-00219 DOOR ASSEMBLY
- 2. 062-00605 CASE
- 3. 030-00046 VACUUM MOTOR
- 4. 042-00044 HEATER COIL

- 5. 062-00623 BUSHING
- 6. 041-00157 EVAPORATOR COIL
- 7. 034-00029 EXPANSION VALVE
- 8. 045-00521 INSULATION

- 9. 071-00680 BACK PANEL
- 10. 033-00003 THERMOSTAT
- 11. 035-00006 RESISTOR
- 12. 071-00143 SHIELD

AIRSTREAM 390/395/396 XL OWNERS MANUAL
2002

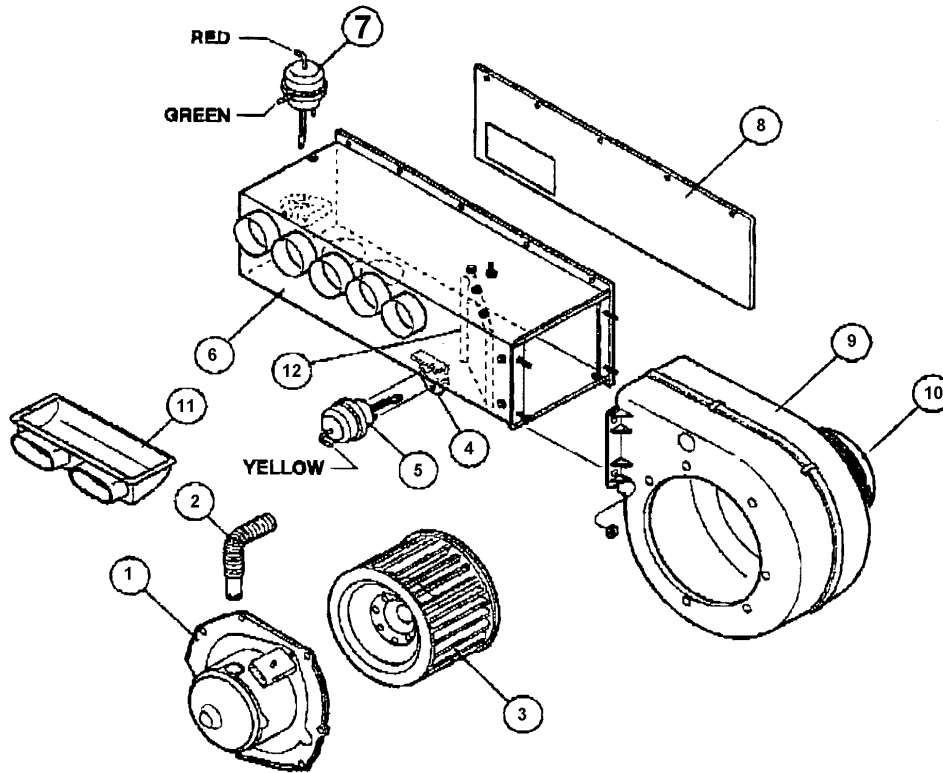

- | | | |
|---------------------------------|-------------------------------|-----------------------------|
| 1. 030-00109 BLOWER MOTOR | 5. 030-00025 VACUUM MOTOR | 9. 062-00113 BLOWER HOUSING |
| 2. 051-00034 VENT HOSE | 6. 071-00763 HOUSING ASSEMBLY | 10. 060-00135 INLET GUIDE |
| 3. 062-00010 BLOWER WHEEL | 7. 030-00048 VACUUM MOTOR | 11. 060-00497 HEATER BOX |
| 4. 070-00234 VAC. MOTOR BRACKET | 8. 071-00762 BACK PANEL | 12. 071-00645 DIVIDER |

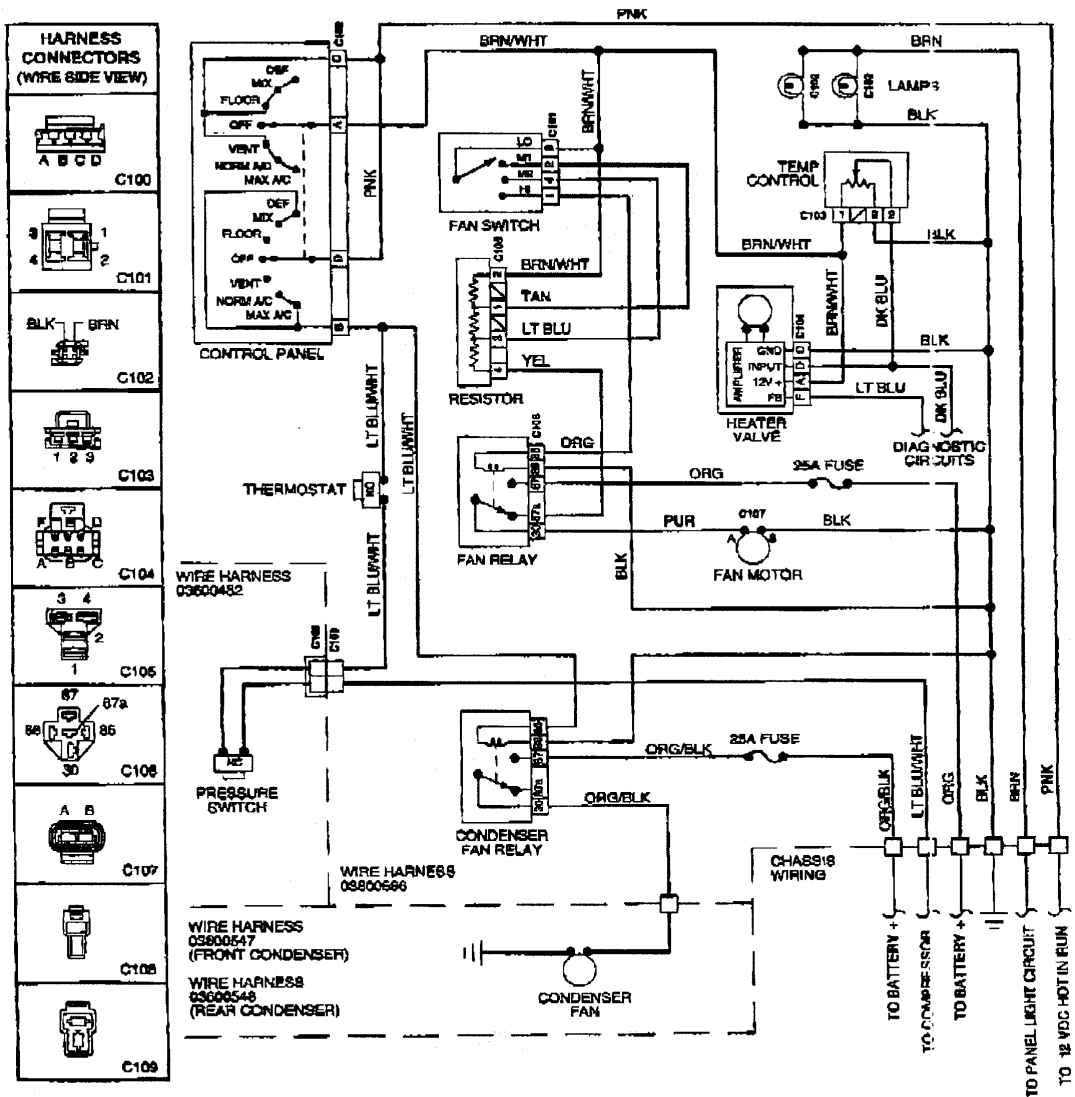

SCS/Frigette MOTORHOME HVAC SYSTEMS

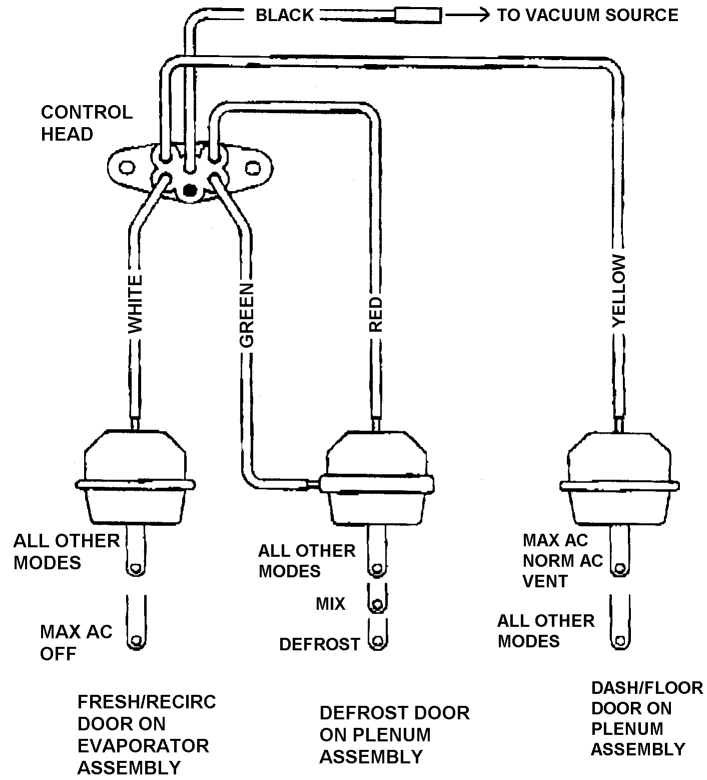

SCS/Frigette MOTORHOME HVAC SYSTEMS

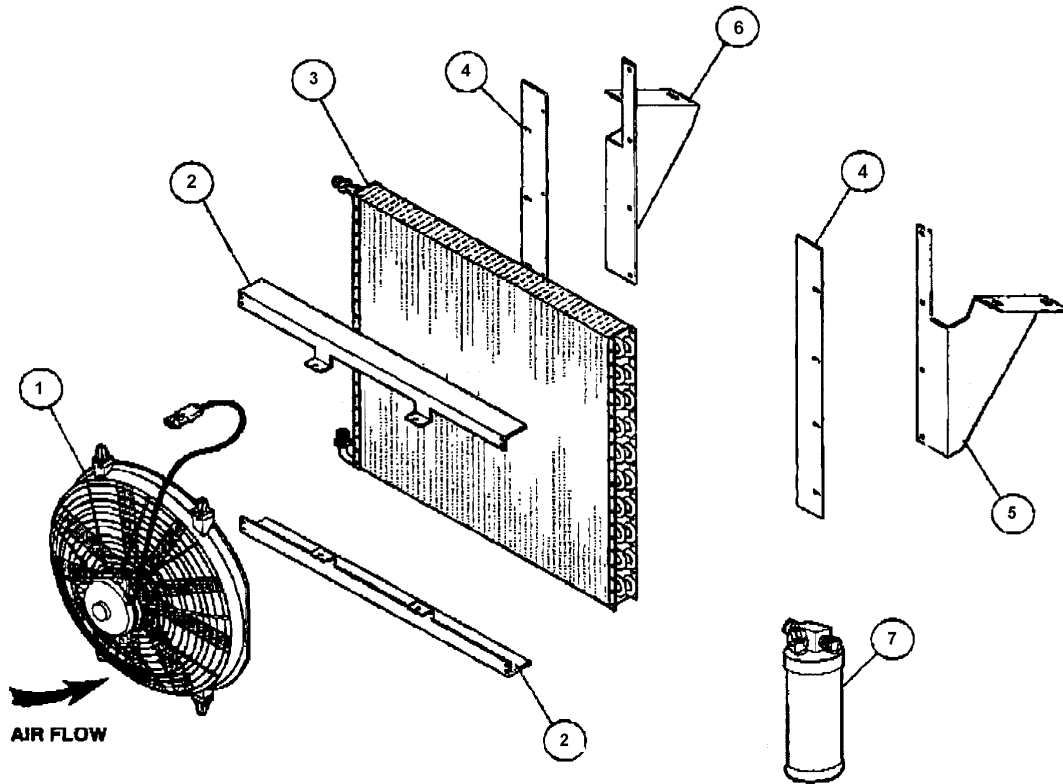

- 1. 086-00329 FAN ASSEMBLY
- 2. 070-00638 BRACKET
- 3. 040-00096 CONDENSER COIL

- 4. 070-00646 BRACKET
- 5. 070-00637 BRACKET
- 6. 070-00647 BRACKET

- 7. 054-00019 RECEIVER DRIER
NS 036-00547 WIRE HARNESS*

*NS = NOT SHOWN

AIRSTREAM 390/395/396 XL OWNERS MANUAL
2002

ELECTRIC STEP

Manufacturer:

Kwikee Products Company
Division of Ashton Corporation
P.O. Box 638
Drain, Oregon 97435
Phone: 503-836-2126

The step is easy and convenient to operate. Just inside the main door is a wall switch for the step. When traveling, leave the switch in the "ON" position - the step will lower when the door is opened and retract when the door is closed.

When parked, open the door so the step is lowered, then shut the switch off. The step will remain in the lowered position and the "step" light on the dash will be extinguished. If left on it will run your engine battery down in about a week.

If you forget and leave the switch off as you leave - No Problem! When the ignition is "ON" the wall switch is by-passed and the step will retract when the door is closed.



WARNING: If the wall switch is turned off, and the step is in the retracted position when the ignition is turned off, the step will not lower when the door is opened. Keep your passengers informed.

AIRSTREAM 390/395/396 XL OWNERS MANUAL 2002

ELECTRIC SCHEMATIC

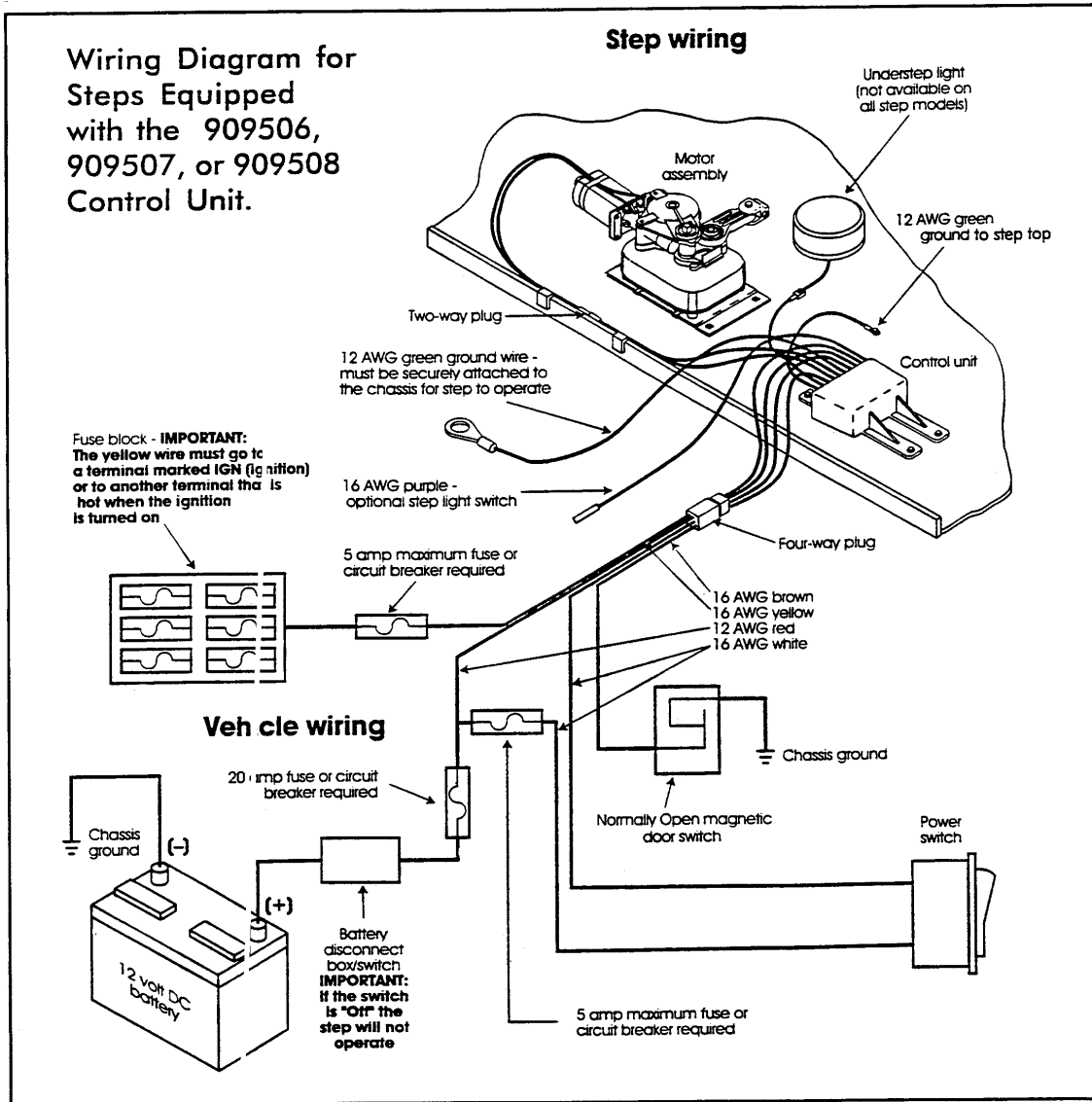

AIRSTREAM 390/395/396 XL OWNERS MANUAL

2002

OPERATING THE STEP

1. After the installation is complete and with the entrance door open, turn the power switch on.
2. Close the door. The step should retract and lock in the "up" position.
3. Open the door. The step should extend and lock in the "down" position with the understep light on.
NOTE: The under step light is not available on all step models.
4. Turn the power switch off. The step should remain in the extended position with the understep light off when the door is closed. Turning off the power with the step retracted will hold the step in a retracted position as well.
5. With the power switch off, the step extended, and the entrance door closed, turn on the vehicle ignition. The ignition override system will go into effect and the step will automatically retract.

NOTE - *If the yellow wire from the four-way connector was not connected to an ignition power source during the installation procedure, the ignition safety system will be inoperative and the step will remain in the extended position. In this case, the power switch must be turned on for the step to retract.*



WARNING: *If the vehicle is driven with the step in the extended position, there is the possibility of causing major damage to both the step and the vehicle.*

6. Turn the vehicle ignition off and open the door. The step will extend and lock in the "down" position. This is the "Last Out" feature.



WARNING: *If the door is opened and closed without allowing the step to fully extend and lock in the "down" position, the step will retract and lock in the "up" position. When the door is reopened, the step will not extend. The power switch must be turned on for the step to extend.*

7. The "Last Out" feature is only operative the first time the door is opened after the vehicle ignition is turned off. **NOTE: If the yellow wire from the four-way connector was not connected to the vehicle fuse block during installation, the "Last Out" feature will not operate.**

When the vehicle ignition is on, the step will always activate with the door movement, regardless of power switch position. **NOTE: This is not valid if the aforementioned yellow wire has not been connected.**

BE SAFE-LOOK BEFORE YOU LEAP

AIRSTREAM 390/395/396 XL OWNERS MANUAL

2002

General Service Notes

If the power wire to the step is disconnected from its source and reconnected, a spark is common. This is caused by the momentary charging of the control unit and does not necessarily indicate the system is staying on, which would cause a drain on the battery. If battery drain is suspected, observe the understep light (if so equipped) while the step is extending. The power switch must be on for the understep light to operate. When the step locks into the down position, the understep light should become noticeably brighter. If it does not, the control may not be shutting off. Turn the power switch off and unplug the four-way plug between the control unit and the vehicle to prevent overheating the step motor.

To further determine that the control is not shutting off, remove the 2 screws from the connector on the step motor leads between the step motor and the control unit. Remove the seal assembly. (See Figure 6 in the Step Test Procedure). Place a voltmeter between the red and yellow motor leads than reconnect the four-way plug. Turn the power switch on. If any voltage registers on the meter, the control is not shutting off and may be defective. When doing this test, switch the voltmeter leads back and forth between the red and yellow motor leads to be sure no voltage registers. If any voltage does register, disconnect the four-way plug to keep the motor from overheating. If zero voltage is present, the control has shut off and is normal.

If the step does not work or operates erratically, such as extending part way and shutting off, the first item that should be checked is the vehicle's battery. The voltage supplied to the step should be at least 12.7 volts DC for well-charged batteries. A battery that registers below 12.7 volts DC may drop as low as 8 volts DC when a load is drawn, such as engaging the step motor. The control unit will shut off if the loaded voltage falls below 9.5 volts DC. The control unit will remember which function it was performing. It will wait between two and five seconds (time depends upon temperature) and will try again to complete the original function. If the supply voltage is still below 9.5 volts DC, the control will go into another delay state. If the supply voltage remains above 9.5 volts DC, the original function will be completed. Should the supply voltage again fall below 9.5 volts DC the system will go into another delay state. It could take a couple of minutes to complete the original function. Low supply voltage may cause erratic operation of the step. Poor ground connections may also cause erratic operation of the step.

The step may also operate erratically if the step is being operated directly from a converter, and the output from the converter is not adequate or properly filtered for clean DC voltage. The converter must be capable of producing a minimum of 30 amps for proper step operation.

If the control unit is hooked up reverse polarity, the step will not operate. If the ground to the control unit is lost, either between the step control unit and the vehicle chassis (the long 10 ga. green ground wire) or between the vehicle battery and the ground (negative battery cable) the step will not function. Make sure the battery terminals and all wire connections are clean and tight. Be sure all wires are of proper gauges or heavier as specified in the wiring diagram.

These general service notes and the Step Test Procedure cover the most common problems associated with Kwikie electric steps. Due to the number of variable conditions available, you may experience symptoms other than those covered. Please feel free to contact the Customer Service Department at I (800) 736-9961 for further information or assistance.

AIRSTREAM 390/395/396 XL OWNERS MANUAL

2002

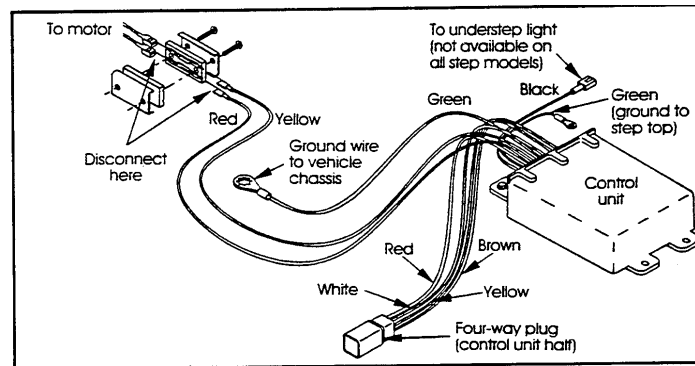

FIGURE 6

STEP TEST PROCEDURE

This Step Test Procedure has been provided as the easiest and quickest way to troubleshoot and test all of the KwikEE automatic electric step functions. It is designed to initially check the step basic functions separately from the RV wiring, thereby determining whether or not the step is malfunctioning. From that initial determination, the procedure goes on to test the various components of the step until the source of the malfunction is located. Using this procedure will shorten and reduce the time spent troubleshooting.

Some portions of this test require additional equipment. This equipment includes: a voltmeter, a well charged 12 volt DC automotive battery, and a 4-way extended-wire pigtail (Part #909336, available from KwikEE Products Company).

⚠ WARNING: 12-volt automotive batteries contain sulfuric acid that can cause severe burns. Avoid contact with the skin, eyes and clothing. 12 volt automotive batteries produce hydrogen gas which is explosive; keep cigarettes, open flames and sparks away from the battery at all times.

Reading this entire procedure prior to beginning the tests is recommended. Should you need assistance in the course of performing this test procedure, feel free to contact KwikEE's toll free Service Line at 1 (800) 736-9961.

Testing the Step

NOTE: Prior to beginning the test procedure, check to be sure that all ground connections are securely fastened with good metal-to-metal contact. A good ground is required for proper step operation.

1. Inspect the step for visible damage that might restrict the step's extension.
2. Obtain a 4-way pigtail connector (part #909336) from KwikEE.
3. Disconnect the 4-way plug on the underside of the step and connect the step-half of the plug with the extended-wire pigtail connector (see Wiring- Schematic).
4. Set a fully charged 12-volt DC automotive battery beside the step. ATTENTION: Do not allow battery terminals to come in contact with the step. Complete a ground for the step tests by connection a 10-gauge wire from the negative (-) post of the battery to the 10-gauge green ground wire from the control unit.
5. For the power supply, attach the red wire from the extended-wire pigtail to the battery's positive (+) post.

AIRSTREAM 390/395/396 XL OWNERS MANUAL

2002

6. With the power and ground connections complete, all functions of the control unit can be checked at the leads to the 4-way extended-wire pigtail. The brown wire is the door switch, the white wire is the power switch, and the yellow wire is the ignition override.



WARNING: Keep all fingers; arms and legs clear of the step mechanism while performing these tests.

7. While holding the white wire to the battery's positive (+) post, touch the brown wire to the battery's negative (-) post. The step should extend. Remove the brown wire and the step should retract.

8. As in Step 7 extend the step again. With the step extended, disconnect the white wire first and then disconnect the brown wire. The step should remain extended.

9. With the step still extended, touch the yellow wire to the battery's positive (+) post. The step should retract.

10. At this point, refer to the control unit. On step models with the numbers #909514, #909515 or #909591, all step functions have been tested. Proceed to step 11. On step models with the numbers #909513, #909516, #909590 or #909592, test the "Last Out" feature by disconnecting the yellow wire and then touching the brown wire to the battery's negative (-) post. The step should extend and remain extended.

11. If any of the step functions do not work, the source of the malfunction is either in the control unit and/or the motor. Proceed to the testing the motor section. If all of the step functions do work, the malfunction is either in the door switch, the power switch or the vehicle wiring. Proceed to testing the 4-way plug - vehicle half section.

Testing the Motor

12. Steps equipped with the permanent magnet motor require disconnecting the motor leads from the control unit before applying power to the motor leads (see Figure 6). To disconnect the motor leads, disassemble the motor lead wire connector seal.

NOTE: Failure to disconnect the motor wire leads from the control unit prior to applying power to the motor leads will damage the control unit and void warranty.

NOTE: Do not cut any motor or control unit wire leads. Any leads that have been cut will void the warranty.

After the motor leads have been disconnected, connecting the motor's red wire lead to the positive (+) post of the battery and the motor's yellow wire lead to the negative (-) post of the battery will extend the step. Reversing the lead connections will retract the step. If the step extends and retracts during this test, the condition of the step motor is good.

Testing the 4-way Plug - Vehicle Half

13. To check the main power source, connect the voltmeter between the red wire from the four-way plug (vehicle half) and the ground terminal at the end of the control unit's 10-gauge green ground wire (See Figure 7). The reading should be a minimum of 12 volts DC.

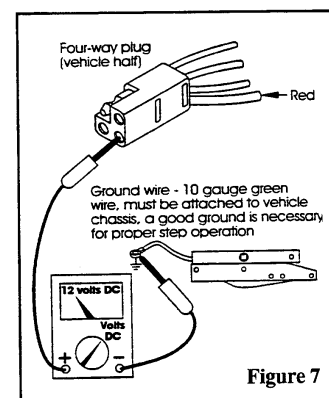

If the voltage reading is low, there may be a loose or corroded connection at the battery, or a low level on the battery itself. If the voltage reading is zero (0) volts, check the 25-amp fuse/circuit breaker, all connections, and the condition of the wiring between the battery and the plug.

AIRSTREAM 390/395/396 XL OWNERS MANUAL

2002

14. To check the power switch, connect the voltmeter between the white wire from the four-way plug (vehicle half) and the terminal at the end of the control unit's 10-gauge green ground wire (see Figure 8). The reading should be a minimum of 12 volts DC (The same as in Step 13) when the switch is on, and zero (0) volts when the switch is off.

If the voltmeter reads zero (0) volts when the power switch is on, there is a problem in the power switch circuit.

Check the 5-amp in-line fuse, the Power Switch itself and the condition of the circuit's wiring and terminal connections.

15. To check the door switch, connect the voltmeter between the red wire from the four-way plug (vehicle half) and the brown wire in the same plug (see Figure 9). The voltage should be about 12 volts DC (the same as in step 13) when the door is open and zero (0) when the door is closed.

If the readings vary (either zero (0) volts when the door is opened or 12 volts continuously) there is a problem in the door switch. Check the door switch and the condition of the circuit's wiring and terminal connections.

16. To check the ignition override system, connect the voltmeter between the yellow wire from the four-way plug (vehicle half) and the ground terminal on the end of the control unit's 10 gauge green ground wire (see Figure 10). The voltage reading should be approximately 12 volts DC when the ignition is on and zero (0) volts when the ignition is off.

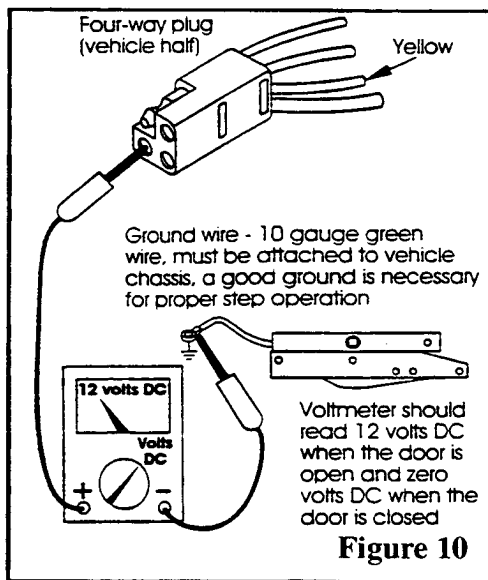
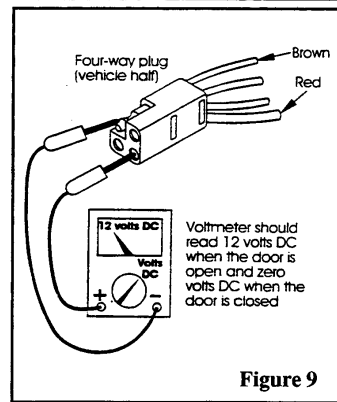
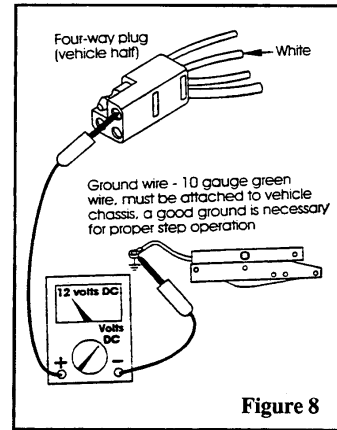

If the reading is zero when the ignition is on, check the terminal connections in the vehicle's fuse/circuit breaker and the condition of the circuit's wiring and terminal connections. **NOTE -The step wiring circuit must be independent. No other device (i.e. alarm systems, step well lights, etc.) can be connected to the step wiring circuit. Any device connected to the steps wiring can cause the step to malfunction and will void the warranty.**

This concludes the Step Test Procedure. At this point, the source of a steps malfunction should be known. If you have additional questions or need more assistance, contact Kwikiee's Service Representative at 1 (800) 736-9961.

AIRSTREAM 390/395/396 XL OWNERS MANUAL

2002

STEP MOTOR ASSEMBLY DIAGRAM

Parts shown in this illustration are only available in kit form and cannot be obtained individually; refer to the illustration below and use the Step Motor Parts Key on the preceding page to select the kit that contains the necessary part.

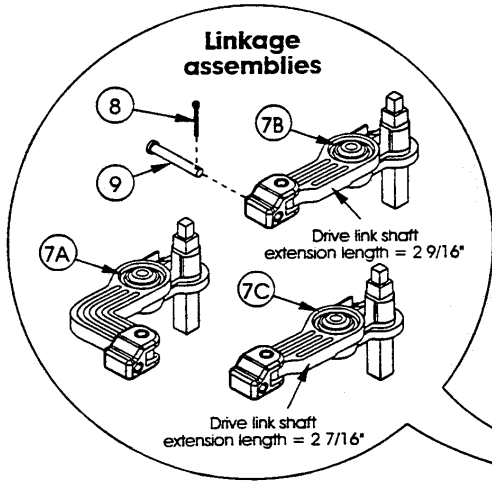

Part#	Description
1	#10 x 1 3/4" self-tapping hex washer-head screw
2	Motor bearing bracket
3	Bearing
4A	Motor
4B	Motor (high torque - for use with 23 Series steps)
5	Adaptor gear
6	Adaptor gear shaft
7A	Linkage assy. (for motor assys. #909502 & #909503)
7B	Linkage assembly (for motor assembly #909501)
7C	Linkage assembly (for motor assembly #909504)
8	Cotter pin
9	Clevis pin
10	Gear case
11	Gear
12	Gear case cover
13	Motor mounting plate
14	1/4-20 x 1 1/4" tri-lobal thread forming screw
15	#6 x 3/4" self-tapping washer-head screw
16	Motor lead weather seal - upper plate
17	Motor lead connector rubber seal
18	Motor lead weather seal - lower plate

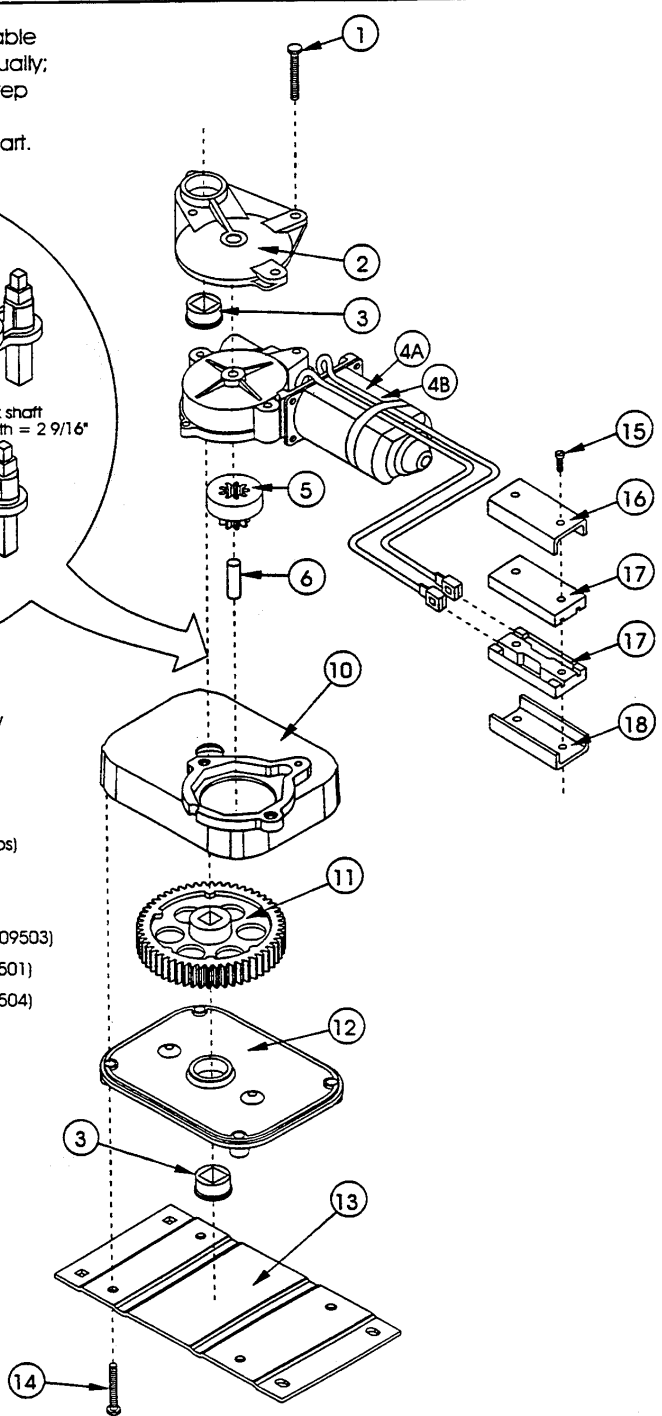
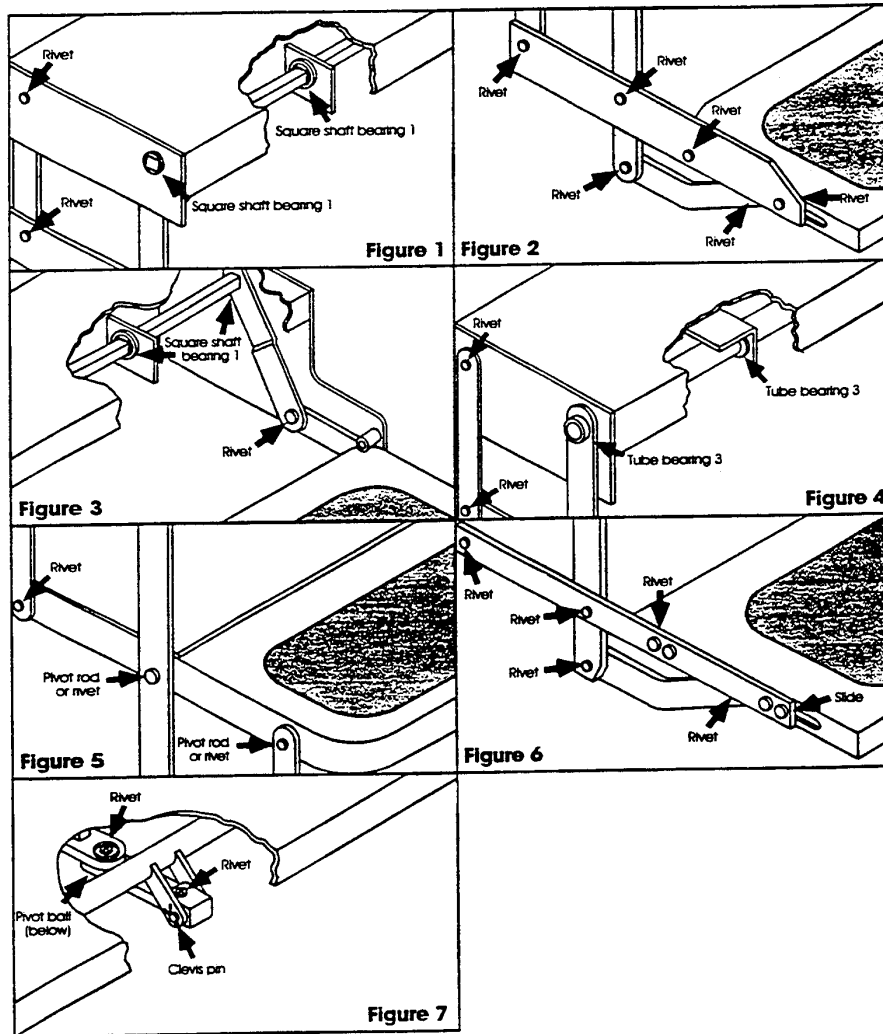

Figure 11

AIRSTREAM 390/395/396 XL OWNERS MANUAL
2002

LUBRICATION AND MAINTENANCE SCHEDULE



Clean all mud, salt, and road grime from step before lubricating. Lubricate all moving parts (bearings, pivot points, slides, clevis pin, and drive linkage ball) every 30 days with a good quality moisture and heat resistant penetrating grease. Kwik-Lube Spray Grease is specially formulated to lubricate Kwik-ee Electric Steps and is recommended for lubricating all moving parts. Refer to the figures below for lubrication locations.

NOTE: Figures are to be used as a general reference only. Some may not pertain to your particular step model. Views are typical to both ends of the steps.

1. Figures 1 & 3 - square shaft bearing - lubricate around outside and under head of bearing.
2. Figure 4 - on step models equipped with plastic cover, this cover will have to be removed to lubricate center bearings. Lubricate bearings under cover every 90 days.
3. Figure 4 - 1" O.D. tube bearing - lubricate around drive tube and between head of bearing and drive leg.

NOTE: We recommend that penetrating oils and silicone lubricants not be used on the step as they do not last.

AIRSTREAM 390/395/396 XL OWNERS MANUAL

2002

STEP WELL COVER

Your motorhome is equipped with a pneumatically powered step well cover.

The switch (valve) is a black lever located in the front of the passenger right hand armrest. The air pressure is supplied by the chassis air ride system. It is normal for the air system to leak down so you may find the cover to be inoperable if the engine has been shut off for a period of time.

The intent of the step cover is to provide the passenger with a "floor" while traveling and then be retracted so the steps can be used when stopped. With this in mind you can see where the loss of air after the motorhome has been shut off for a time is not a problem. When you park the motorhome you'll normally retract the step cover so you can at least get out and stretch your legs. If you happen to lose air pressure before retracting the step cover just starting the engine for a few minutes will replenish the air supply.



WARNING: Do not operate the pneumatic cover while standing in the step well.

Windshield Wiper

The wiper system is made by Trico and uses a 28" blade. The washer bottle and motor is located in the roadside front compartment.

Air Supply

There is an air supply chuck located in the roadside front compartment. A hose and fitting is included with the tool kit for your convenience. The air is supplied by the chassis compressor and will be replenished only with the ignition on.

AIRSTREAM 390/395/396 XL OWNERS MANUAL
2002
NOTES

AIRSTREAM 390/395/396 XL OWNERS MANUAL

2002

CAMPING

SAFETY

As always, safety should be one of your top priorities. Make sure you, and everyone traveling with you, can operate the main door and exit window rapidly without light.

 **WARNING:** *The escape window (which is the rear, roadside windows) is opened by rotating the red latch handle down then pushing the sash out. Sliding it straight up opens the pleated shade. The window operation should be checked each trip.*

 **WARNING:** *At each campsite make sure you have not parked in such a manner as to block the operation of the escape window by being too close to trees, fences or other impediments. Scenic views are one reason for traveling, but don't park so the beautiful lake or steep cliff is just outside your escape window.*

 **WARNING:** *Read the directions carefully on the fire extinguisher. If there is any doubt on the operation, you and your family should practice, then replace or recharge the extinguisher. You will find your local fire department will be happy to assist you and answer any questions.*

 **WARNING:**

***DON'T SMOKE IN BED!
KEEP MATCHES OUT OF REACH OF SMALL CHILDREN! DON'T CLEAN
WITH FLAMMABLE MATERIAL!
KEEP FLAMMABLE MATERIAL AWAY FROM OPEN FLAME!***

We have all heard these warnings many times, but they are still among the leading causes of fires.

Other safety information on the LPG system of your motorhome is located in the Plumbing Section of this manual.

SMOKE ALARM

OPERATION, TESTING

OPERATION: The smoke detector is operating once a fresh battery is installed and testing is complete. When products of combustion are sensed, the unit sounds a loud 85 db pulsating alarm until the air is cleared.

HUSH CONTROL: The "HUSH" feature has the capability of temporarily desensitizing the alarm circuit for approximately 7 minutes. **This** feature is to be used only when a known alarm condition, such as smoke from cooking, activates the alarm. The smoke detector is desensitized by pushing the "HUSH" button on the smoke detector cover. If the smoke is not too dense, the alarm will silence immediately and "Chirp" every 30-40 seconds for approximately 7 minutes. This indicates that the alarm is in a temporarily desensitized condition. The smoke alarm will automatically reset after approximately 7 minutes and sound the alarm if particles of combustion are still present. The "HUSH" feature can be used repeatedly until the air has been cleared of the condition causing the alarm.

AIRSTREAM 390/395/396 XL OWNERS MANUAL

2002

NOTE: DENSE SMOKE WILL OVERRIDE THE HUSH CONTROL FEATURE AND SOUND A CONTINUOUS ALARM.

CAUTION: BEFORE USING THE ALARM HUSH FEATURE, IDENTIFY THE SOURCE OF THE SMOKE AND BE CERTAIN A SAFE CONDITION EXISTS.

FLASHING L.E.D. LIGHT: This smoke detector is equipped with a flashing red indicator light. The light is located under the test button and will flash every 30-40 seconds to indicate that the smoke detector is receiving power.

TESTING: Test by pushing the test button on the cover and holding it down for a minimum of 2 seconds. This will sound the alarm if all the electronic circuitry, horn and battery are working. If no alarm sounds the unit has defective batteries or other failure. You can also test the alarm by blowing smoke into it.

TEST THE ALARM WEEKLY TO ENSURE PROPER OPERATION. Erratic or low sound coming from your alarm may indicate a defective detector, and it should be returned for service.

FALSE ALARMS

Smoke detectors are designed to minimize false alarms. Cigarette smoke will not normally set off the alarm, unless the smoke is blown directly into the detector. Combustion particles from cooking may set off the alarm if the detector is located close to the cooking area. Large quantities of combustible particles are generated from spills or when broiling. Using the fan on a range hood which vents to the outside (non-recirculating type) will also help remove these combustible products from the kitchen.

MODEL 0916 HAS A "HUSH" CONTROL that is extremely useful in a kitchen area or other areas prone to nuisance alarms. For more information refer to **OPERATION AND TESTING**.

If the detector does alarm, check for fires first. If a fire is discovered, get out and call the fire department. If no fire is present, check to see if other reasons may have caused the alarm.

MAINTENANCE

BATTERY REPLACEMENT

To replace-the battery remove the detector from the mounting plate by rotating the detector in the direction of the "OFF" arrow on the cover.

The Model 0916 Smoke Detector uses one (1) 9-volt battery. The **SMOKE DETECTOR** is powered by a 9V carbon zinc battery (alkaline battery may also be used). A fresh battery should last for one year under normal operating condition. This detector has a low battery monitor circuit that will cause the detector to "chirp" approximately every 30-40 seconds for a minimum of seven (7) days when the battery gets low. Replace the battery when this condition occurs. ***USE ONLY THE FOLLOWING 9 VOLT BATTERIES FOR SMOKE DETECTOR REPLACEMENT***

Carbon-zinc type: EVEREADY 216 OR 1222, GOLD PEAK 1604P OR 1604S

Alkaline type: EVEREADY 522; DURACELL MN 1604, Gold Peak 1604A

Lithium type: ULTRALIFE U9VL. NOTE:

REGULAR TESTING IS RECOMMENDED.

 **WARNING** ***USE ONLY THE BATTERIES SPECIFIED. USE OF DIFFERENT BATTERIES MAY HAVE A DETRIMENTAL EFFECT ON THE SMOKE DETECTOR.***

AIRSTREAM 390/395/396 XL OWNERS MANUAL

2002

NOTE: IF AFTER BATTERY REPLACEMENT, THE UNIT CONTINUES TO CHIRP, WAIT FOR APPROXIMATELY 7 MINUTES. THE "HUSH" FEATURE MAY HAVE BEEN ACTIVATED ACCIDENTALLY WHILE CHANGING THE BATTERIES AND WILL RESET AUTOMATICALLY

CLEANING YOUR DETECTOR:

To clean your detector remove it from the mounting bracket as outlined in the beginning of this section.

You can clean the interior of your detector (sensing chamber) by using your vacuum cleaner hose and vacuuming through the openings around the perimeter of the detector.

The outside of the detector can be wiped with a damp cloth.

AFTER CLEANING, REINSTALL YOUR DETECTOR. TEST YOUR DETECTOR BY USING THE TEST BUTTON.

LIMITATIONS OF SMOKE ALARMS:



WARNING: Smoke detectors are devices that can provide early warning of possible fires at a reasonable cost; however, detectors have sensing limitations. Ionization type detectors offer a broad range of fire sensing capability but are better at detecting fast flaming fires than slow smoldering fires. Photoelectric detectors sense smoldering fires better than flaming fires. Home fires develop in different ways and are often unpredictable. Neither type of detector (photoelectric or ionization) is always best, and a given detector may not always provide warning of a fire. Also, smoke detectors do have limitations. For a battery powered detector the battery must be of the specified type, in good condition, and installed properly. AC powered detectors will not operate if AC power has been cut off such as by an electrical fire or an open fuse. Smoke detectors must be tested regularly to make sure the batteries and the detector circuits are in good operating condition.

Smoke detectors cannot provide an alarm if smoke does not reach the detector. Therefore, smoke detectors may not sense fires starting in chimneys, walls, on roofs, on the other side of a closed door or on a different floor. If the detector is located outside the bedroom or on a different floor, it may not wake up a sound sleeper. The use of alcohol or drugs may also impair ones ability to hear the smoke alarm. For maximum protection a smoke detector should be installed in each sleeping area on every level of a home.

Although smoke detectors can help save lives by providing an early warning of a fire, they are not a substitute for an insurance policy. Homeowners and renters should have adequate insurance to protect their lives and property.

GOOD SAFETY HABITS

DEVELOP AND PRACTICE A PLAN OF ESCAPE:

- Make a floor plan indicating all doors and windows and at least two (2) escape routes from each room. Second story windows may need a rope or chain ladder.
- Have a family meeting and discuss your escape plan, showing everyone what to do in case of fire.
- Determine a place outside your home where you all can meet if a fire occurs.
- Familiarize everyone with the sound of the Smoke Alarm and train him or her to leave your home when they hear it.
- Practice a fire drill at least every six months. Practice allows you to test your plan before an emergency; you may not be able to reach your children. *It is important they know what to do.*

AIRSTREAM 390/395/396 XL OWNERS MANUAL

2002

WHAT TO DO WHEN THE ALARM SOUNDS:

- Leave immediately by your escape plan. Every second counts, so don't waste time getting dressed or picking up valuables.
- In leaving, don't open any inside door without first feeling its surface. If hot, or if you see smoke seeping through cracks, don't open that door! Instead use your alternate exit. If the inside of the door is cool, place your shoulder against it, open it slightly and be ready to slam it shut if heat and smoke rush in.
- Stay close to the floor if the air is smoky. Breathe shallowly through a cloth, wet if possible.
- Once outside go to your selected meeting place and make sure everyone is there.
- Call the fire department from your neighbor's home - *not from yours!*
- Don't return to your home until the fire officials say that it is all right to do so.

There are situations where a smoke detector may not be effective to protect against fire as stated in the NFPA standards 72.

For instance:

- a) Smoking in bed;
- b) Leaving children home alone.
- c) Cleaning with flammable liquids, such as gasoline.

Further information on fire safety can be obtained in a pamphlet titled "IN A FIRE SECONDS COUNT" published by the NFPA, Batterymarch Park, Quincy, Mass. 02269.

SERVICE AND WARRANTY

If after reviewing this manual you feel that your smoke alarm is defective in any way, do not tamper with the unit. Return it for servicing to: FYRNETICS, INC., 1055 STEVENSON CT./STE 102W, ROSELLE, IL 60172. (See Warranty for in-warranty returns).

CARBON MONOXIDE ALARM

The following information is highlights from the folder provided by the alarm manufacturer. The folder, with more detailed information, is contained in your Owners' Packet.

Test detector immediately following installation and weekly for proper operation by pushing the test button until the YELLOW L.E.D. lights and a short beep is heard (approximately three seconds). Release the button. The detector will then test itself for proper operation. At completion of the self-test, the alarm will sound and both L.E.D.s will light for 3/4 of a second. The detector then resumes normal operation.

NORMAL OPERATION

In normal operation the detector will flash the RED L.E.D. once every 30 seconds.

WARNING CONDITION

If the COSTAR senses a low level of CO The YELLOW L.E.D. will light and the detector will beep every three seconds warning that CO is present. The area should immediately be ventilated. A concentration of 60 PPM within 67 minutes will cause the warning condition. Pushing the test button will silence the warning signal but the YELLOW L.E.D. will stay on. After two hours the warning signal will sound again if the CO source has not been eliminated. If the condition persists there is a possibility that it may cause the unit to enter alarm condition (below). If this occurs pushing the reset button will silence the alarm for 30 minutes.

AIRSTREAM 390/395/396 XL OWNERS MANUAL

2002

ALARM CONDITION

If the COSTAR senses unsafe levels of CO, the RED L.E.D. will light up and the alarm will sound. The alarm condition will be signified by a repetitive alarm-sounding pattern of approximately 4.5 seconds on 1.5 second off. **Immediate evacuation is required.** Pushing the test button will silence the alarm once for approximately 4 minutes.

After approximately 4 minutes the alarm will once again sound until the unsafe CO concentration is removed.

FAULT CONDITION

Periodically the detector's measurement circuit is tested. If an error is detected, the detector will sound twice and the YELLOW L.E.D. will flash twice every 30 seconds. This is an indication of circuit malfunction and that the detector requires immediate servicing.

MAINTENANCE

Battery Replacement:

If tamper resistant pin has been used, refer to "tamper resistant locking pin" for removal instructions.

To replace the battery remove the detector from the mounting plate by rotating the detector in the direction of the "OFF" arrow on the cover.

The **Model 9L-i CO Detector** uses one (1) 9-volt battery. A 9V alkaline battery powers the CO DETECTOR. A fresh battery should last for one year under normal operating conditions. This detector has a low battery monitor circuit which will cause the detector to "chirp" and the red LED to flash approximately every 30-40 seconds for a minimum of seven (7) days when the battery gets low. Replace the battery when this condition occurs. **USE ONLY THE FOLLOWING 9 VOLT BATTERIES FOR CO DETECTOR REPLACEMENT.**

Alkaline type: EVEREADY522; DURACELL MN1604; GOLD PEAK 1604A

Lithium type: ULTRALIFE U9VL

NOTE: REGULAR TESTING IS RECOMMENDED.



WARNING: USE ONLY THE BATTERIES SPECIFIED. USE OF DIFFERENT BATTERIES MAY HAVE A DETRIMENTAL EFFECT ON THE CO DETECTOR.

CLEANING YOUR DETECTOR:

To clean your detector remove it from the mounting bracket as outlined in the beginning of this section. You can clean the interior of your detector by using your vacuum cleaner hose and vacuuming through the openings around the perimeter of the detector. The outside can be wiped with a damp cloth.

AFTER CLEANING, REINSTALL YOUR DETECTOR. TEST YOUR DETECTOR BY USING THE TEST BUTTON.

Test detector weekly for proper operation by pushing the test button until the YELLOW L.E.D. lights and a short beep is heard (approximately three seconds). Release the button. The detector will then test itself for proper operation. At completion of the self-test, the alarm will sound and both L.E.D.s will light for 3/4 of a second. The detector then resumes normal operation.

SERVICE AND WARRANTY

If after reviewing this manual you feel that your CO Detector is defective in any way, do not tamper with the unit. Return it for servicing to: **Quantum Group, Inc., 11211 Sorrento Valley Road, Suite Valley Road, Suite V. San Diego, CA 92121.**

Or call us toll free (800) 432-5599

E-mail address: mktsls@qginc.com

AIRSTREAM 390/395/396 XL OWNERS MANUAL

2002

LP GAS DETECTOR

In the kitchen area of your unit, approximately six inches above the floor, is the LP gas detector. LP gas is a mixture of gases produced and sold commercially as a fuel for heating and cooking appliances. LP gas is highly flammable and, as a result, can be explosive if ignited under certain circumstances. LP gas is heavier than air and, if confined in a closed space, will accumulate close to the floor. When the LP gas concentration in your unit exceeds 2000 PPM the detector will provide a visual and audible alarm by sounding a buzzer and flashing the red LED two times per second.



WARNING:

Activation of this detector indicates the presence of LP gas, which can cause an explosion and/or fire. This normally indicates a leak in the LP gas installation or a LP gas appliance. Extinguish all open flames, open your windows and door and evacuate the unit immediately. Do not activate any electrical switch. Turn off the LP at your gas bottle(s). DO NOT RE-ENTER YOUR UNIT UNTIL A QUALIFIED REPAIR TECHNICIAN HAS CORRECTED THE PROBLEM.

OPERATION

Your LP gas detector is wired directly to your vehicle battery and incorporates a 1-amp in-line fuse. When the device is operating normally the green LED will be lit.



WARNING: It is not recommended that the detector be disconnected from the battery during periods of storage. There is a small heater on the sensor of the device, which "burns" away impurities in the air during periods of normal use. During periods when power is interrupted, impurities can build up on the sensor. When power is returned to the detector the detector alarm may activate until the impurities are "burned" off. This could take a number of hours, during which time the alarm will be constantly "on".

DETECTOR TEST

Press the test button for 5 to 6 seconds until the alarm sounds then release the test button. The red LED should flash and the alarm sound for approximately 4 minutes. This test should be performed at least once a week during normal vehicle operation, and after periods of storage, and before each trip.

LOW VOLTAGE

Below 10 VDC the detector will continue to operate but will blink alternately green and orange. Below 8 VDC the unit will behave erratically and will eventually shut off. To ensure proper operation, do not operate the unit below 10 VDC.

COMPONENT FAILURE

The failure of any circuit component will cause the detector to display a continuous orange LED fault light and a short beep indicating failure. If this occurs, immediately contact your dealer or Airstream Customer Service for the name of the nearest detector service center.

Please read the operating instructions for your detector, which have been supplied with the paper work of your unit.



WARNING: Have a professional check your system if you have any doubts.

AIRSTREAM 390/395/396 XL OWNERS MANUAL

2002

OVERNIGHT STOP

In time you will develop a knack for spotting wonderful little roadside locations by turning off the main highway and exploring. There are many modern recreational vehicle parks, including State, County and Federal parks with good facilities, where you may obtain hookups of electrical, water and sewer connections. Directories are published which describe in detail these parks and tell what is available in the way of services and hookups.

Overnight or Weekend Trips

On overnight or weekend trips, chances are you will not use up the capacity of the sewage holding tank, deplete the water supply, or run down the batteries which supply the living area 12 volt current.

Longer Trip

On a longer trip, when you have stayed where sewer connections and utility hookups were not available, it will be necessary for you to stop from time to time to dispose of the waste in the holding tank and replenish the water supply. Many gas stations (chain and individually owned) have installed sanitary dumping stations for just this purpose. Booklets are available which list these dumping stations.

When you stop for the night, your Airstream motorhome is built to be safely parked in any spot that is relatively level and where the ground is firm. Your facilities are with you. You are self-contained. Try to pick as level a parking spot as possible.

All you need to do to enjoy self-contained luxury is to:

1. Turn on the LP Gas supply and light the appliance pilots if required.
2. Turn on the water pump and open the faucets until the air is expelled from the system.
3. Deploy the slide out if so equipped and you desire the extra space.

Before moving on, turn off the LP gas and the water pump, check you campsite, both for cleanliness and also to be sure you haven't left anything behind. Make sure everything is properly stowed.

Hydraulic Leveling Jacks

Some models are equipped with hydraulic leveling jacks that can be deployed. Complete instructions are included with the Owners Packet. Be sure to read the directions completely prior to operating the jacks. The jacks will be able to level your unit in most modern campgrounds. However, their capabilities are limited, and in some situations you will have to use planks to level the coach.

WINTER TRAVELING

Traveling in your motorhome during the cold winter months can be a most exhilarating experience. There are, of course, certain precautions that must be taken as you would in your home in low temperatures.



WARNING: Always shut off the LP gas when gasoline is added to the fuel tank.

Some states do not allow LPG to be turned on while moving. While traveling in these states you must use your common sense. How cold is it? How long will it be before you can turn the heat back on? Is the temperature dropping or rising? Remember, the wind chill factor when driving 50 MPH will cause the interior of the motorhome to cool much faster than when it is parked.

AIRSTREAM 390/395/396 XL OWNERS MANUAL

2002

1. You must have a plentiful supply of propane gas.
2. If your stay is longer than overnight, you should endeavor to have 120-volt electricity available. The batteries, fully charged, will not last more than about 15 hours in freezing weather. Of course, you can run your generator to recharge the batteries, or even use the generator continually. Since the generator starts off the same battery as the engine, it is recommended to start the generator prior to shutting off the engine. This will prevent running the engine battery down should there be a difficulty in starting the generator in the cold temperatures.
3. Minimize use of electricity if 120-volt power source is not available.
4. Leave cabinet doors, bed doors and wardrobe doors slightly open at flight to allow circulation of air in and around all furniture components
5. Use propylene glycol type antifreeze in waste and drain water tanks to prevent freezing. Quantity of antifreeze needed will vary with ambient temperature and the amount of liquids in tank.
6. For extended stays in cold weather, insulate the water line outside the motorhome. You should remember that low temperatures in combination with high winds cause an equivalent chill temperature much below what your thermometer is reading. For instance, with an outside temperature of zero degrees, and the wind velocity of 10 miles per hour, the equivalent chill temperature is minus 20' F. The exterior water faucet has an in-line valve inside the motorhome. In below freezing temperatures, shut off the valve inside and open the exterior brass valve so it will drain.

Condensation

It is also important to guard against excessive humidity inside your motorhome during winter campouts. When windows and window frames fog up or "sweat," it means that there is too much moisture in the air. Moisture comes from water vapor and water vapor is the direct result of water evaporating.

Many things such as baths and showers, boiling foods, washing dishes, washing clothes, even breathing, contribute to evaporation. The inside air can only absorb so much of this moisture before it becomes saturated. At this point it can hold no more, and any additional water vapor condenses back to liquid water in the form of droplets on any available cool, solid surface. Temperature has a direct effect on the air's saturation point. Cold air holds less moisture than warm air. For this reason, the air immediately adjacent to cold outside walls and windows cools down and causes water vapor to condense and form moisture droplets, even though warmer inside surfaces are still dry.

The best way to keep condensation under control is to reduce moisture-producing activities. It is important to provide adequate ventilation and keep the air circulating as much as possible.

Use your exhaust fans to remove moisture before water vapor mixes with the air. Open windows slightly once in a while, while operating fans, to bring in drier outside air and aid in overall air circulation. In extremely cold weather, when outside ventilation is not practical, it may be necessary to use a small dehumidifier to aid in reducing condensation.

There is no substitute for common sense in cold weather.

Note: The Airstream motorhome is built as a recreational vehicle and is not intended as a permanent dwelling or for more than temporary use in sub-freezing temperatures.

AIRSTREAM 390/395/396 XL OWNERS MANUAL

2002

EXTENDED STAY

Making a long trip is not very different from making a weekend excursion. Since everything you need is right at hand, you are at home wherever you go. When packing for an extended trip, take everything you need, but only what you need. Some models are equipped with Hydraulic Leveling Jacks that can be deployed. Complete instructions are included with the Owners Packet. Be sure to read the directions completely prior to operating the jacks.

When you plan to stay in the same place for several days, weeks or months, you will want your motorhome to be as level as possible. Check the attitude with a small spirit level set on the inside work counter. If a correction is necessary, then you must first level from side to side. This can be done most easily by driving up a small ramp consisting of 2" x 6" boards tapered at both ends. **WE DO NOT RECOMMEND PLACING TIRES IN A HOLE FOR LEVELING. See tire warnings on page C-4.**

CAMPGROUND SETUP

Hook Up to Water by attaching a ½" minimum high-pressure water hose to the city water service, or the hose from the water reel if so equipped.

The **110-volt power cord** is an electrically operated cord reel in the first compartment located behind the roadside rear wheels. Turning the switch to "out" will extend the power cord so it can be plugged into City Power Service.



WARNING: If adapters are required make sure the polarity is correct and the "ground" function is not lost.

A **Cable TV and Telephone Hookup** is located on the roadside power cord compartment of the motorhome. It is already wired into the existing system, so the exterior connection is all that is required.

To use the **Generator** you simply start it. All switching is done automatically. The generator can be started either from your interior monitor panel, armrest switch, bedroom switch, or the switch on the generator itself.

It is easier on your generator and appliances if you'll allow the generator to reach its normal operating speed (about a minute) prior to applying heavy current loads.

Hook your **Waste Drain Hose into the Sewer Disposal Facility** and attach to the drain outlet in your motorhome. For details on this procedure see Drain and Waste System Section.

Turn on the **gas supply** and light the oven pilot. Lighting a top range burner to bleed any air from the system will make it easier to start other appliances.

The **range exhaust fan** has an exterior door that must be unlatched to be effective. You will see the two small twist latches if you look at the fan from outside the motor home. In most circumstances you can leave the door unlatched. During storage and adverse weather conditions, latching the door is recommended.

When you stay for extended periods where electric or water hookups are not available, you must make regular checks on the condition of your 12-volt battery and the contents of your water tank. Carry drinking water in a clean bucket to refill your tank. When your waste tank nears capacity, move your motorhome to a dumping location.

AIRSTREAM 390/395/396 XL OWNERS MANUAL
2002

CAUTION: Read and follow all warning labels in the coach and safety instructions in the Power Gear owner manual and as posted inside your coach.

To operate the SLIDE-OUT rooms you MUST first remove the interior travel locks. These are located on the top of the room on the interior of the coach and are out of your normal sight. There are two and they provide pressure between the exterior wall of the coach and the top facer board on the room. They have caming action and the tension is adjustable. The first time you remove them you'll probably need to stand on a stable step stool to see how the cam is released. After seeing their simple operation you may be able to operate them from the floor according to your height and strength. Also make sure the driver's seat is forward enough to clear the room. Push and hold the rocker switch located at the top of the control panel in the hallway. You'll easily be able to tell by the sound of the mechanism when the room is fully extended or retracted. Instructions for manual retraction and extension of the room during a power failure are in the Power gear owner's manual.

NOTE: Before a slide-out room can be deployed the ignition switch must be off. We also recommend leveling the coach prior to deploying the slide-out.

To operate the SLIDE OUT ROOM, push and hold the rocker switch located at the top of the control panel in the hallway. You'll easily be able to tell by the sound of the mechanism when the room is fully extended or retracted.

WARNING! PLEASE READ

**LEVEL AND STABILIZE UNIT
PRIOR TO OPERATING SLIDE-OUT
ROOM. FAILURE TO LEVEL UNIT MAY
CAUSE THE ROOM TO OPERATE IMPROPERLY OR
CAUSE DAMAGE.**

**MAKE SURE THERE IS ADEQUATE CLEARANCE
TO OUTSIDE OBJECTS BEFORE SLIDE-OUT ROOM
IS EXTENDED.**

**TO PREVENT ACCIDENTAL INJURY, STAND CLEAR
OF SLIDE-OUT ROOM WHILE ROOM IS IN MOTION.**

**REMOVE TRAVEL LOCKS BEFORE ATTEMPTING
TO OPEN SLIDE-OUT ROOM.**

**NEVER ATTEMPT TO MOVE MOTORHOME WITH
ROOM EXTENDED.**

INSTALL TRAVEL LOCKS PRIOR TO TRAVEL.

**TRAVEL LOCKS TO BE POSITIONED & ADJUSTED
PROPERLY TO HOLD ROOM FIRMLY IN POSITION
FOR TRAVEL.**

AIRSTREAM 390/395/396 XL OWNERS MANUAL

2002

EXTERIOR

The roof of your Airstream Land Yacht motorhome is a fiberglass compound. If it is damaged contact the Airstream customer service department and ask for the Service Bulletin on roof repairs.

The walls, front, and rear end are fiberglass that is custom painted by Carrera Designs with an automotive finish. As a general rule of thumb, we recommend the motorhome be washed about every four weeks and waxed in the spring and fall.

ALWAYS CLEAN YOUR MOTORHOME IN THE SHADE OR ON A CLOUDY DAY WHEN THE SKIN IS COOL. Oil, grease, dust and dirt may be removed by washing with any mild non-abrasive soap or detergent. Do not use hot water. Cleaning should be followed by a thorough clean water rinse. Drying the unit with a chamois or a soft cloth can prevent spots and streaks.

After cleaning and drying, a good grade of nonabrasive automotive paste or liquid wax will increase the life of the finish, especially in coastal areas where the finish is exposed to salt air, or in polluted industrial areas. It will also protect the shell from minor scratches and make subsequent cleaning easier.

If your vehicle is exposed to pollen, bird droppings, tree sap, or the like, especially in hot and sunny weather, wash it as often as necessary to keep it clean. If you do not, your paint will be damaged. Take similar precautions if your vehicle is exposed to chemical industrial fallout. If asphalt remains on the motorhome after washing, use a small amount of 100% mineral spirits on a rag and wipe the spots individually, being careful not to scratch the finish.

It is recommended that the caulking and sealant used in external seams and joints such as window frames, light bezels, beltline and rub-rail molding, etc., be checked regularly. If this material has dried out and becomes cracked or checked, or if a portion has fallen out, it should be replaced with fresh material to prevent possible rain leaks. Caulking and sealing material is available from your motorhome dealer.

Caution: Do not use high-pressure vehicle washes with harsh detergents or automatic truck washes.

FRONT END PROTECTIVE FILM

Your vehicle has a 3M protective film on the front end.

1. To remove stains or bugs on the 3-M film on the front of motorhomes, soak affected areas with soapy water for several minutes and wipe off-may need to be repeated several times.
2. If number one doesn't work-make a solution of 70% rubbing alcohol and 30% warm water and gently wipe over area needing cleaned.
3. If the above steps do not remove stains or dirt, use a non-abrasive polish on the affected areas and wipe off.

Coach Guard may be contacted at 1-800-262-4100 for addition information on this product.

AIRSTREAM 390/395/396 XL OWNERS MANUAL

2002

Roof Ladder and Storage

For traveling, the lower section of the ladder should be removed and stored in one of your lower compartments.

To remove, pull out the cross pins in the lower sockets then pull the bottom of the ladder out of the sockets. This will allow the top of the ladder to be unhooked freeing it for storage.

CAUTION. Roof storage is limited to 250 pounds evenly distributed.

MAIN DOOR LOCK

LOCK ASSEMBLY, MAIN DOOR

1. Outside housing assembly
2. Inside plate
3. Striker bolt
4. Caged nut
5. Rotary latch

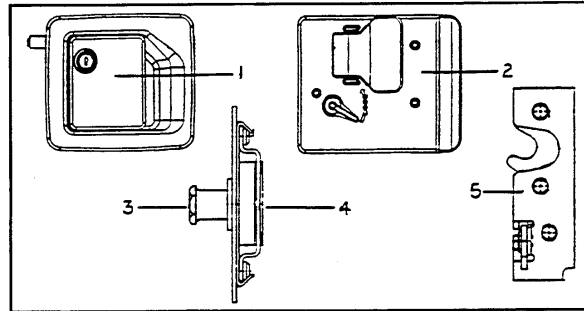

KEYLESS DOOR LOCK

Operation

The dead bolt portion of your motorhome may be controlled by radio signals produced by the key fob shown below. One characteristic of this system is the one second delay after a pad has been depressed.

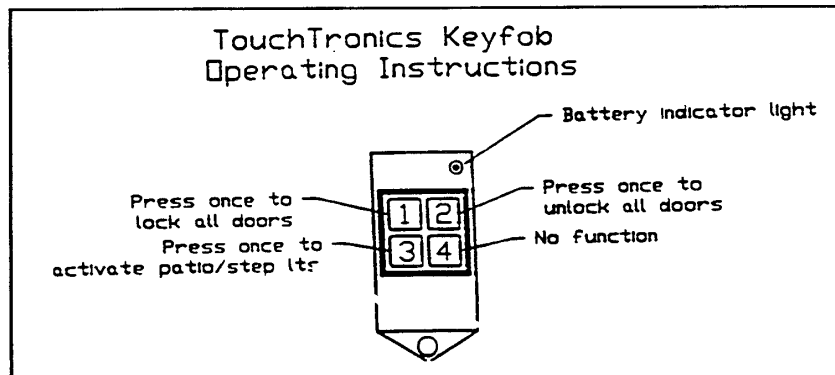

NOTE: When you use the keypad to turn the patio lights ON you must also use the keypad to turn them OFF. The same goes for the switch inside the door ... if you turn the lights on with this switch, you must use the same switch to turn them off. You cannot turn the lights on with the keypad and off with the switch.

SERVICE

There are four major components operating the door locks; control module/receiver, dash switch, relay, and drive motors. The control module is mounted on the inside wall just behind the main door. The relay operates in conjunction with the dash switch and is located up under the left hand side of the dash. The drive motors, located at each lock, are polarity sensitive. When testing you'll find the wires at the drive motors will switch from positive to negative and vice versa as the key fob or dash switch is being operated. When using the dash switch the relay under the dash performs the polarity switching functions and the control module/receiver serves the same function when the key fob is used. A detailed wire layout is provided in the electrical section of this manual.

AIRSTREAM 390/395/396 XL OWNERS MANUAL

2002

INTERIOR

The luxurious interior of your Airstream motorhome has been designed for comfort, convenience, durability and appearance. An understanding of the operational procedures and maintenance techniques of the interior appointments will add to your pleasures, as well as to the long life of your motorhome.

Lounges

To convert the Deluxe Sofa into a bed, pull the armrest straight up and out of their bracket, grasp the front edge of the seat, raise and pull it toward the aisle of the motorhome. The backrest will slide down into place automatically.

Rear Bed

On diesel models the bed top raises to reveal the engine cover for access to top of the engine. Gas rod props assist the bed top raising. The engine cover latches to the bottom of the bed top.



WARNING - The lifting and supporting strength of the gas props vary according to temperature. Props that support the bed top when hot may let the bed close rapidly when cold.

Cocktail Chairs and Recliners

The cocktail chairs have four adjustments. As you sit in the chair, two levers will protrude on the left side. Releasing one lever allows the chair to rotate. The other lever allows the chair to slide forward and back.

The recliners supplied with the motorhome have side levers that can swivel, lock, or recline the chair according to which chair was ordered with your coach.

CAUTION: Rotating the chair when it's slid back against the wall can damage the upholstery. Position the chair so it isn't chafing when in transit.

Fabric Cleaning

All material should be professionally dry cleaned to remove any overall soiled condition. These materials may be spot cleaned, however, using the cleanability code instructions as listed. Sample swatches are furnished to our dealers. The dealer will be able to give you the cleaning code and part number for the fabrics used in your particular motorhome.

Floor Tile

The tile is standard ceramic tile and grout and should be cleaned and cared for with products designed for tile floors.

AIRSTREAM 390/395/396 XL OWNERS MANUAL

2002

The following are the cleanability code instructions for the various fabrics used in the Airstream motorhomes:

Cleanability Codes

CODE W-S

Fabric care. Spot clean this fabric either with a mild solvent or a water-based cleaning agent. When using a solvent or dry cleaning product, follow instructions carefully and clean only in a well-ventilated room. Avoid any product that contains highly toxic carbon tetrachloride. You may also use an upholstery shampoo product or the foam from a mild detergent. With either method, pretest a small area before proceeding. Use professional furniture cleaner when an overall soiled condition is reached.

CODE S

Fabric care. Spot clean, using a mild, water-free solvent or dry-cleaning product. Carefully follow instructions on such product. Clean only in a well-ventilated room. Avoid any product containing carbon tetrachloride, which is highly toxic. Pretest small area before proceeding. Use professional furniture cleaner when an overall soiled condition is reached.

CODE W

Fabric care. Spot clean, using the foam only from a water-based cleaning agent, such as mild detergent or non-solvent upholstery shampoo product. Apply foam with a soft brush in a circular motion. Vacuum when dry. Pretest small area before proceeding. Use professional furniture cleaner when an overall soiled condition is reached. The manufacturer of the fabric designed the above code.

CAUTION: Never remove cushion cover for separate cleaning or washing. Any tumble cleaning method can destroy the backing, shrink or otherwise damage upholstery.



WARNING : Keep your furniture and family safe from fires caused by careless smoking. Do not smoke when drowsy. Remove immediately any flowing ash or a lighted cigarette that falls on furniture. Smoldering smoking material can cause upholstered furniture fires.

SHADES

The day/night shades are opened and closed by grasping both knobs and sliding the shade straight up and down. Your choice of blind density is instantly available by using the appropriate set of knobs.

CARPET

The carpet can be cleaned with any good commercial carpet cleaner, or with a detergent and water. **HOWEVER, BE CAREFUL NOT TO SOAK THE CARPET WITH WATER.**

LAVATORY SINK

The lavatory sink is a very dense material called KARRAN. In the unlikely event of it ever being stained, powdered cleansers such as Ajax or Comet may be used or even Scotch-Brite® pads. The color is constant through the thickness of the material.

AIRSTREAM 390/395/396 XL OWNERS MANUAL

2002

COUNTER AREAS

The counter areas around the sink are Corian and can be cleaned with soap and water, or you can use a common solvent on tough spots. Be sure no abrasive cleaner is used, as there is the possibility it could scratch the surface. A protective pad should always be placed under hot utensils.

WALL CLEANING

Guilford of Main wall fabrics are color fast to the standard wet and dry cleaning procedures and are also highly resistant to most spot cleaning solvents. Standard Care Level S-W would identify the finished fabric. Avoid excessive brushing or rubbing during cleaning practices to prevent fuzzing of the fabric surface.

Because of the very low absorption properties of polyester, soil will tend to remain on the fiber surface and, therefore, is usually removed without need of vigorous treatment. To prevent overall soiling, frequent vacuuming or light brushing to remove dust and grime is recommended. Oil or grease type spots will respond to mild solvent or dry cleaning agents. The blotting technique, without rubbing, should be sufficient to remove most spots.

Solvent Cleaner: Spot clean, using a water-free solvent or dry cleaning products. Clean only in a well-ventilated room and avoid any product containing carbon tetrachloride or other toxic materials. Pretest small area before proceeding.

Water-Based Cleaner: Spot clean, using the foam only from a water-based cleaning agent such as a mild detergent or non-solvent upholstery shampoo products. Apply foam with a soft brush in a circular motion. Vacuum when dry. Pretest small area before proceeding.

When an overall soiled condition has been reached, use a professional furniture cleaning service for recommendations in cleaning the fabric.

DRAWERS

Drawer removal - pull drawer out to stop then raise front of drawer to clear rollers.

CAUTION: Do not use any abrasive material on the vinyl-covered walls.

BATHROOM

CAUTION: The lavatory bowl and countertop in your bathroom should be cleaned with soap or detergent. NEVER USE SCOURING POWDER.

SHOWER STALL

To clean your ULTRA/GLAS shower stall unit, use warm water and one of the stronger liquid detergents. Do not use abrasive cleaners; they may scratch and dull the surface of your ULTRA/GLAS unit. Stubborn stains can be removed with solvents such as turpentine, paint thinner or acetone. Restore dulled areas by rubbing with an automotive-type liquid cleaner, and then put the soft glow back into your ULTRA/GLAS unit with a light application of liquid wax.



WARNING: Do not wax the floor of the stall without using a bath mat afterward to prevent a dangerous slippery floor condition.

AIRSTREAM 390/395/396 XL OWNERS MANUAL
2002
NOTES

AIRSTREAM 390/395/396 XL OWNERS MANUAL

2002

PLUMBING

LPG SYSTEM

Your motorhome is equipped with a permanently mounted tank for LPG (Liquid Petroleum Gas). LPG burns with a clean blue flame. There are two basic types of LPG in common usage: Butane and Propane. Butane is widely used where temperatures are normally above freezing the year round, and Propane is used where subfreezing temperatures are common, since Butane freezes at 32°F as compared to -40°F for Propane. **ALL OF THE ORIFICES IN THE LPG APPLIANCES ARE OF THE UNIVERSAL TYPE THAT WILL BURN EITHER FUEL.** How long a full tank of gas will last is dependent on usage. In cold weather, when you are using the furnace, large amounts of hot water, and cooking extensively, you will naturally use more than you will in warm weather, when you may do limited cooking. On the average, with normal cooking and other appliance use, you can probably count on one month of usage from the tank.

If you have allowed the tank to run out, air may have gotten into the lines. In this event the air must be forced out through the lines by gas pressure before you can light the pilots. Hold a match to the pilot of the appliance closest to the tanks until it lights and stays lit. Then move to the next closest, etc.

 **WARNING: All pilot lights and appliances must be turned off during refueling of motorhome fuel tank and permanently mounted LPG tank. Gas lines should be checked periodically for leaks with ammonia free soapy water. Do not use open flame.**

CAUTION: Moisture in the LPG tank will cause a malfunction of the regulator in controlling proper pressure. This may result in the flame lifting off the burner, or the flame may go out frequently. Many refueling stations will add approximately 1/4 to 1/2 gallon of alcohol to lower the moisture temperature. Moisture will then pass through the regulator without the formation of ice crystals.

 **WARNING: If gas can be smelled, appliance pilots fail to stay on, or any other abnormal situation occurs, shut off tank valve immediately and call on a qualified LPG service center or Airstream Service Center.**

LPG Regulator

The LPG regulators used on Airstream motorhomes are designed for low-pressure service, with a normal outlet pressure setting of 11.5 water column. Only personnel trained in the proper procedures, codes, standards, etc., should service regulators.

Have the regulator inspected each time the tank is refilled. Make sure the regulator vent opening on both first and second stage regulators does not become plugged by mud, insects, snow, ice, paint, etc. Vents must remain open.

Replace any regulator that has had water in the spring case, or shows evidence of external corrosion, or corrosion inside the spring case. Closely examine regulators directly connected to the container valve by means of a solid POL adapter (horizontal mounting) for signs of corrosion. (An Airstream Service Center is recommended for this service.)

AIRSTREAM 390/395/396 XL OWNERS MANUAL
2002

BASIC RULES FOR SAFETY

 **WARNING:** DO NOT store LP containers within vehicle. LP containers are equipped with safety devices that vent gas should the pressure become excessive.

 **WARNING:** DO NOT use cooking appliances for comfort heating. Cooking appliances need fresh air for safe operation. Before operation open overhead vent or turn on exhaust fan and open window.

A warning label has been located in the cooking area to remind you to provide an adequate supply of fresh air for combustion. Unlike homes, the amount of oxygen supply is limited due to the size of the recreational vehicle, and proper ventilation when using the cooking appliances will avoid dangers of asphyxiation. It is especially important that cooking appliances not be used for comfort heating as the danger of asphyxiation is greater when the appliance is used for long periods of time.

 **WARNING:** Portable fuel burning equipment, including wood and charcoal grills and stoves, shall not be used inside the recreational vehicle. The use of this equipment inside the recreational vehicle may cause fires or asphyxiation.

 **WARNING:** A Warning Label has been located near the LP gas container. This label reads: DO NOT FILL CONTAINER (S) TO MORE THAN 80% PERCENT OF CAPACITY. Overfilling the LP gas container can result in uncontrolled gas flow that can cause fire or explosion. A properly filled container will contain approximately 80 percent of its volume as liquid LP gas.

 **WARNING:** Do not bring or store LP gas containers, gasoline or other flammable liquids inside the vehicle because a fire or explosion may result.

 **WARNING:**

If you smell gas:

1. Extinguish any open flames, pilot lights and all smoking materials.
2. Do not touch electrical switches.
3. Shut off the gas supply at the tank valve(s) or gas supply connection.
4. Open doors and other ventilating openings.
5. Leave the area until odor clears.
6. Have the gas system checked and leakage source corrected before using again.

 **WARNING:** LP gas regulators must always be installed with the diaphragm vent facing downward. Regulators that are not in compartments have been equipped with a protective cover. Make sure that regulator vent faces downward and that cover is kept in place to minimize vent blockage that could result in excessive gas pressure causing fire or explosion.

AIRSTREAM 390/395/396 XL OWNERS MANUAL
2002

LP TANK INSTALLATION

The regulator at the L.P. tank is under a black plastic cover. The protective cover certainly helps to keep the vent on the regulator from getting clogged by wasps or ice, but should still be checked regularly to make sure the vent remains clear.

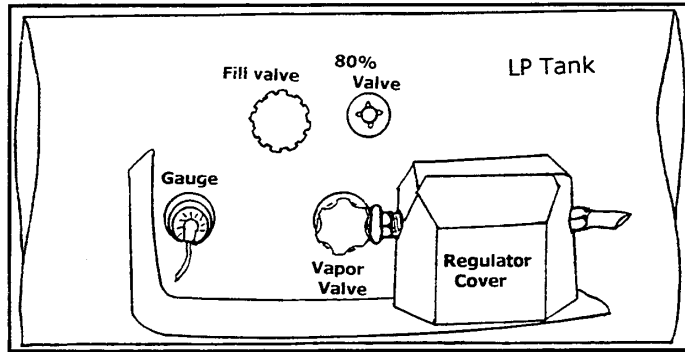

! WARNING: Do not attempt to seal regulator cover.

! WARNING: Check vent each time tank is filled to make sure it is clear of obstructions.

Gas Regulator Removal/Replacement

1. Shut off main gas supply at the tank.
2. Remove the plastic protective cover from the regulator assembly
3. Using two wrenches, one to hold the line fitting and one to turn the flare nut, disconnect the regulator from the flexible rubber line.
4. Disconnect the regulator from the tank fitting. Remove regulator.
5. To replace, reverse the removal procedures.

AIRSTREAM 390/395/396 XL OWNERS MANUAL

2002

<p>943537</p> <p>A. RANGE TOP - MAGIC CHEF 85RB-3BT 17,500 BTU, AGA/CGA, P/N 690348</p> <p>B. WTR HTR - ATVDDD G6A-6 8,800 BTU, AGA/CGA, P/N 690180</p> <p>C. REFRIG - DOMETIC RM 3862 1500 BTU, AGA/CGA, P/N 690370-02</p> <p>D. FURNACE - HYDRDFLAME 8535 34,000 BTU, AGA/CGA, P/N 690274</p> <p>E. FURNACE - HYDRDFLAME 8535 16,000 BTU, AGA/CGA, P/N 690274-02</p>	<p>LET DATE E.C.N. REVISION RECORD BY</p> <p>4/99 4741B PRODUCTION RELEASE JCH</p> <p>A 10/99 4802 REV PIPE LENGTH WAS 23.00 DW</p> <p>B 1/00 4818 REV. PRINT TO MAKE CSA DWG. DW</p>	<p>NOTE: (B) SEE DWG. 943490C FOR THE CSA LP GAS SYSTEM.</p> <p>TOTAL DEVELOPED LENGTH 62.5 TOTAL BTU DEMAND - 77800 PIPE SIZE DETERMINED BY WORST CASE GAS FLOW TEST SUPPORT GAS LINES MAX 48" PITCH W/ RUBBER LINED CLAMPS. RIGID ANCHOR BLACK PIPE WITHIN 6' OF BEGINNING AND BRANCH ENDS.</p>		<table border="1" style="width: 100%; border-collapse: collapse;"> <tr> <td>18</td><td>600008</td><td>TUBING COPPER 3/800</td><td>80 FT</td></tr> <tr> <td>17</td><td>600008</td><td>TUBING COPPER 3/800</td><td>70 FT</td></tr> <tr> <td>16</td><td>600008</td><td>TUBING COPPER 3/800</td><td>70 FT</td></tr> <tr> <td>15</td><td>600008</td><td>TUBING COPPER 3/800</td><td>20 FT</td></tr> <tr> <td>14</td><td>600008</td><td>TUBING COPPER 3/800</td><td>60 FT</td></tr> <tr> <td>12</td><td>601515</td><td>FITTING BRASS 1/4X1/4 INVERT FLAR</td><td>1 EA</td></tr> <tr> <td>11</td><td>601280</td><td>90D BRASS ELBOW 1/4MPT X 1/4FPT</td><td>1 EA</td></tr> <tr> <td>10</td><td>601674</td><td>LP GAS REGULATOR</td><td>1 EA</td></tr> <tr> <td>9</td><td>201649</td><td>ACCESS COVER LP REGULATOR</td><td>1 EA</td></tr> <tr> <td>8</td><td>452546</td><td>BRACKET LP REGULATOR</td><td>2 EA</td></tr> <tr> <td>7</td><td>601661</td><td>NIPPLE, BRASS 1/2 X 1/2 MPT</td><td>1 EA</td></tr> <tr> <td>6</td><td>600435</td><td>FORGED FLARE NUTS 3/8IN</td><td>10 EA</td></tr> <tr> <td>5</td><td>601412-08</td><td>CONNECTOR-M, .50 PIPE TO .38 TUBE</td><td>3 EA</td></tr> <tr> <td>4</td><td>601409</td><td>1/2 TEES</td><td>3 EA</td></tr> <tr> <td>3</td><td>601408</td><td>1/2" 90 DEGREE ELBOW</td><td>5 EA</td></tr> <tr> <td>1</td><td>601732</td><td>HOSE LP TANK TO REGULATOR .36"</td><td>1 EA</td></tr> </table>	18	600008	TUBING COPPER 3/800	80 FT	17	600008	TUBING COPPER 3/800	70 FT	16	600008	TUBING COPPER 3/800	70 FT	15	600008	TUBING COPPER 3/800	20 FT	14	600008	TUBING COPPER 3/800	60 FT	12	601515	FITTING BRASS 1/4X1/4 INVERT FLAR	1 EA	11	601280	90D BRASS ELBOW 1/4MPT X 1/4FPT	1 EA	10	601674	LP GAS REGULATOR	1 EA	9	201649	ACCESS COVER LP REGULATOR	1 EA	8	452546	BRACKET LP REGULATOR	2 EA	7	601661	NIPPLE, BRASS 1/2 X 1/2 MPT	1 EA	6	600435	FORGED FLARE NUTS 3/8IN	10 EA	5	601412-08	CONNECTOR-M, .50 PIPE TO .38 TUBE	3 EA	4	601409	1/2 TEES	3 EA	3	601408	1/2" 90 DEGREE ELBOW	5 EA	1	601732	HOSE LP TANK TO REGULATOR .36"	1 EA
18	600008	TUBING COPPER 3/800	80 FT																																																																	
17	600008	TUBING COPPER 3/800	70 FT																																																																	
16	600008	TUBING COPPER 3/800	70 FT																																																																	
15	600008	TUBING COPPER 3/800	20 FT																																																																	
14	600008	TUBING COPPER 3/800	60 FT																																																																	
12	601515	FITTING BRASS 1/4X1/4 INVERT FLAR	1 EA																																																																	
11	601280	90D BRASS ELBOW 1/4MPT X 1/4FPT	1 EA																																																																	
10	601674	LP GAS REGULATOR	1 EA																																																																	
9	201649	ACCESS COVER LP REGULATOR	1 EA																																																																	
8	452546	BRACKET LP REGULATOR	2 EA																																																																	
7	601661	NIPPLE, BRASS 1/2 X 1/2 MPT	1 EA																																																																	
6	600435	FORGED FLARE NUTS 3/8IN	10 EA																																																																	
5	601412-08	CONNECTOR-M, .50 PIPE TO .38 TUBE	3 EA																																																																	
4	601409	1/2 TEES	3 EA																																																																	
3	601408	1/2" 90 DEGREE ELBOW	5 EA																																																																	
1	601732	HOSE LP TANK TO REGULATOR .36"	1 EA																																																																	

ITEM	PART NUMBER	DESCRIPTION	QTY	UM
TOLERANCES				
±				
NEXT ASSY				
TITLE LP GAS SYSTEM				
PRODUCT LINE 390 XL MH				
DRAWN BY JCH				
APPROVED BY				
SCALE 1=24	DATE 04/16/99	DRAWING NUMBER 943537	REV. B	

AIRSTREAM 390/395/396 XL OWNERS MANUAL

2002

WATER SYSTEM - SELF-CONTAINED

Most plumbing functions are accomplished in the plumbing utility compartment on the roadside of your motorhome. To fill your water tank, hook up a garden hose to the city water inlet then open the water tank fill valve in the upper right corner of the compartment. The water level can be monitored on your control panel above the range or the tank can be filled until water is expelled out of the tank overflow and is seen running on the ground under the vehicle.

NOTE: Once the water level has reached the height of the overflow, water will continue to be expelled for a few minutes after the fill valve is closed.

If it is more convenient for you, a water fill is also located on the side of the vehicle. Open the small access door, unscrew the cap, pull the air plug, insert water hose and fill. As noted above, water will be expelled from an overflow valve for a short time once the tank is full and the fill hose has been removed.

Open the hot side of the galley or lavatory faucet and turn on the water pump switch located on the monitor panel. For some time the open faucet will only sputter. This is because the water heater is being filled and air is being pushed out through the lines. Be sure water heater by-pass valves are in normal flow position and water is in the water heater before lighting beginning operation of the water heater on gas or 110-volt. See the figure below. Once the water heater is full a steady stream of water will come from the faucet. Now open a cold faucet. It will sputter for a short time, but will soon expel a steady stream. All other faucets can now be opened until all air is expelled.

Once the system is filled with water and the faucets closed, the water pump will shut off. When a faucet is opened the pump will come back on automatically. If the faucet is just barely open it is normal for the pump to cycle on and off rapidly.

Water pressure at some campgrounds may be low. The water pump can be turned on to assist the city water hookup pressure. Be sure there is some water in the fresh water tank. The pump will only use the water that is needed out of the tank to bring the pressure up to the usual standard. The water pump should be turned off when the trailer is left unattended.

Water heater by-pass valves are located under the galley. The shelf system under the sink has to be removed to access the valves that are on top of the heater. Remove the several screws anchoring the shelf assembly and take shelf assembly completely out.

Open valves "A" and "B" for normal usage. Close Valves "A" and "B", then open valve "C" for winterizing.

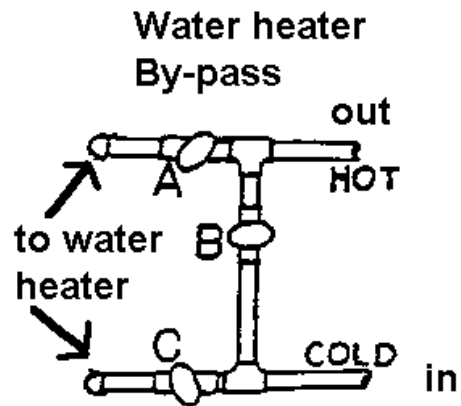

AIRSTREAM 390/395/396 XL OWNERS MANUAL

2002

WATER PUMP AND STRAINER

Water pump access is in the lower exterior compartment on the curbside just in front of the rear wheels. Once the exterior door is raised, the pump can be found behind the small access door in the upper right corner of the storage area.

To clean strainer screen, first remove inlet connection from pump side of strainer. This will allow the intake side of the strainer to be rotated about 1/8 turn counter clockwise and removed. The screen part of the strainer will now be accessible for cleaning.

When reassembling, only rotate the inlet side of the strainer until the stops are felt. The “O” ring performs sealing and too much pressure will only break the strainer.

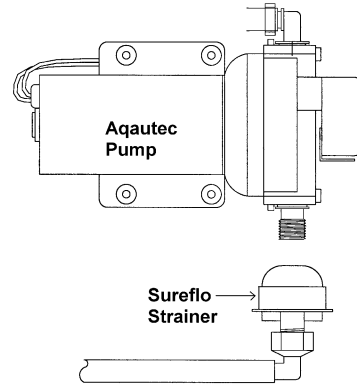

Cleaning Water Storage Tank

1. Prepare sodium hypochlorite solution using potable water and household bleach (5 1/4 to 6%) in the ratio of 1/4-cup bleach to 1 gallon of water. (Common household bleaches are Purex and Chlorox.)
2. Pour 1 gallon of hypochlorite solution for each 15 gallons of capacity into the empty water tank.
3. Add enough potable water to completely fill the water system.
4. Allow closed system to stand for three hours.
5. Drain the hypochlorite solution from the system and refill with potable water.
6. Excessive hypochlorite taste or odor remaining in the water system is removed by rinsing the system with a vinegar solution mixed in the ratio of 1 quart of vinegar to 5 gallons of water.
7. Drain the system and flush with potable water.

AIRSTREAM 390/395/396 XL OWNERS MANUAL

2002

WATER PUMP

Manufacturer:

Aquatec
17422 Pullman Street
Irvine, CA 92614
800 975-9995
949 225-2200
Fax 949 225-2222
www.aquatec.com

Aquajet RV Series.

This revolutionary pump employs state-of-the-art electronics to automatically control motor speed the pump actually adjusts its speed as you open and close water fixtures. The Aquajet RVs exclusive soft start feature eliminates annoying rapid cycling, and its exclusive 5-valve design can deliver twice the flow and pressure conventional RV industry pumps.

OPERATIONAL AND INSTALLATION GUIDELINES AQUAJET RV PUMP

(Partial Reprint. Please contact Aquatec for complete instructions.)

Please read these Operational and Installation Guidelines before installing or operating the AQUAJET RV PUMP. If additional help is needed, please consult the Factory.

CAUTIONS:

- A. The pump is equipped with an electrical speed controller; please insure that electrical connections are made in accordance with these instructions.
- B. The pump is equipped with a pressure sensing demand switch, which controls the maximum operating pressure as set at the Factory. Never subject the pump to pressures above 125 PST (9.5 bars).
- C. Never operate the pump in a harsh environment or hazardous atmosphere, since motor brush and switch may cause electrical arcing.
- D. Pump head materials are designed for use with water only. Do not use with petroleum products.
- E. As long as there is inlet water pressure, the pump will not stop forward flow of water even if the motor is turned off. Be sure the system has a positive means of shutting off water supply.
- F. Always consider electrical shock hazards when working with and handling electrical equipment. If uncertain, consult an Electrician. Electrical wiring should only be done by a qualified Electrician per local and State Electrical Codes.

Do not subject the pump to extreme high or low (freezing) temperatures while in operation. (Operating ambient temperature range is 32° to 115° F).

The pump will only prime if all pressure is relieved from the outlet port

AIRSTREAM 390/395/396 XL OWNERS MANUAL

2002

ELECTRICAL:

- A. The Aquajet RV pump has a motor speed controller that is factory pre-set to operate at a minimum current of 10 amps while operating on a 12 VDC system. A 15-amp fuse must protect the electrical system.
- B. The motor speed controller has a built in heat sink. The temperature of this exposed aluminum surface may reach 200° after extended running.
- C. Care must be taken to insure proper connection of the positive wires (red to red), and negative black wires. Reversing these lead wires will damage the electrical circuit board.
- D. The built in pressure sensing demand switch is factory preset to turn off the pump automatically at 65 PSI.

Trouble Shooting

MOTOR DOES NOT OPERATE.

- Is battery discharged?
- Are any wires disconnected?
- Are terminals corroded'?
- Is switch in "ON" position?
- Is fuse good?
- Is water frozen in pump head?

MOTOR RUNS BUT NO WATER FLOWS.

- Is water tank empty?
- Are there kinks in the inlet hose?
- Is air leaking into inlet hose fittings?
- Is inlet line or in-line filter plugged?
- If using a filter, check the line just before the filter.
- Is outlet hose kinked?

AQUAJET RV Pump

Model: 5503-4V15-B636

Identifying The Part Number

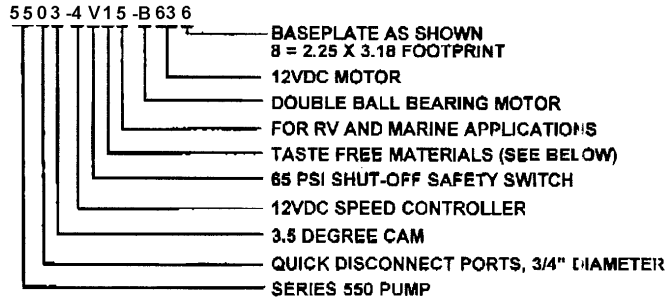

SPECIFICATIONS:

- **MOTOR:**
 - TYPE: 12 VDC, Permanent Magnet, Totally Enclosed, Non-Ventilated
 - LEADS: 14 AWG, 12" Long, Black Negative, Red Positive
DO NOT REVERSE
 - TEMP. LIMITS: Safe to 150°F (66°C)
 - DUTY CYCLE: See Heat Rise Graph
- **SPEED CONTROLLER:** Factory Set to Approximately 10 Amps Max. Thermally Protected to Avoid Component Damage.
CAUTION: Exterior Surfaces (heat sink), May Exceed 150°F After Only 5 Minutes of Operation.
- **PUMP DESIGN:** 5 Chamber Diaphragm Pump, Self Priming, Capable of Being Run Dry
- **TYPICAL APPLICATION:** Water Pressurization for RV and Marine
- **MATERIALS:**
 - PUMP HOUSINGS: Polypropylene
 - CONTROLLER HOUSING: Nylon
 - VALVES: EPDM
 - DIAPHRAGM: Santoprene
 - FASTENERS: Stainless Steel
- **LIQUID TEMPERATURE:** 140°F (60°C) Max.
- **PUMP CERTIFICATIONS:** IAPMO, NSF
- **PRIMING CAPABILITIES:** 13 Feet
- **FITTINGS:**

TYPE	SHAPE	HOSE BARB SIZE		
		1/2"	5/8"	3/4"
HOSE BARB	STRAIGHT	QB6-554	QB6-555	QB6-556
HOSE BARB	ELBOW	QB6-554	QB6-555	QB6-556

THREADED FOR USE WITH PRE-FILTER QTB-556

WEIGHT: 8 lbs.

Aquatec Water Systems, Inc.
17422 Pullman
Irvine, CA 92614
Sales: 949-225-2200
Fax: 949-225-2222

www.aquatec.com

DOCUMENT: DS5503-4V15-B636
ISSUED: 3/3/00
REVISED: 3/3/00

AIRSTREAM 390/395/396 XL OWNERS MANUAL
2002
NOTES

AIRSTREAM 390/395/396 XL OWNERS MANUAL

2002

CITY WATER HOOKUP

In your utility compartment on the roadside of the motorhome are the city water hose connection and various other valves. They are clearly marked and your dealer should have explained the functions of each at time of purchase.

NOTE: When you use the "fresh water tank fill" valve and fill the tank it will expel any overflow under the coach. When you turn the fill valve off, the overflow will not cease immediately, but will slowly taper off.

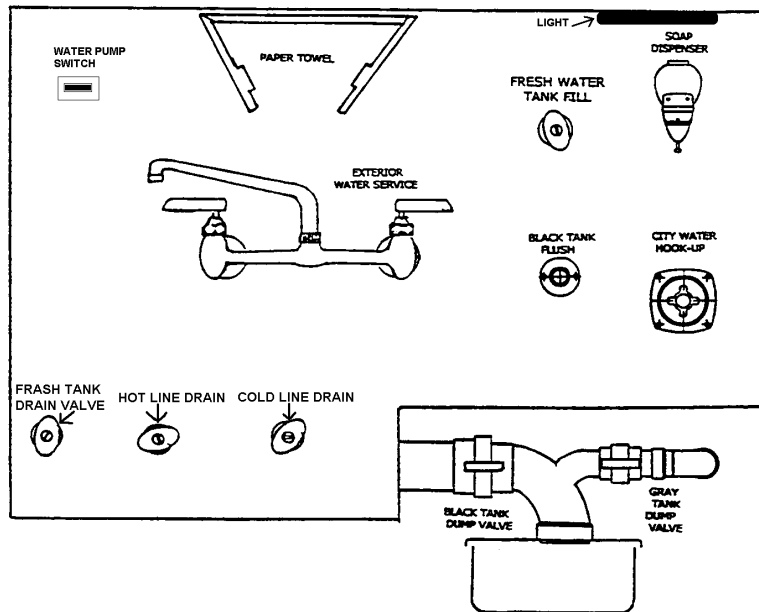

Use a high-pressure hose of at least ½" diameter. It should be one that is tasteless, odorless and non-toxic designed for RV use. The city water inlet is a standard garden hose thread. We suggest you carry two lengths of hose. This way you have the ability to reach hookups further away than normal, plus you have a spare hose should one fail or become damaged unexpectedly. Turn the water heater bypass to the normal flow position as described under self-contained.

After hooking up the hose and turning on the city water valve provided in the park, slowly open a faucet. There will be a lot of spurts and sputtering until all the air is expelled from the motorhome system. If the water heater is empty it will take some time before all the air is expelled and you get a steady flow of water at the faucet. Once a steady flow is achieved at one faucet the others should be opened long enough to expel the air in the lines going to them.

Water pressure at some campgrounds may be low. The water pump can be turned on to assist the city water hookup pressure. Be sure there is some water in the fresh water tank. The pump will only use the water that is needed out of the tank to bring the pressure up to the usual standard. The water pump should be turned off when the trailer is left unattended.

Your plumbing system has a built in pressure regulator to protect your lines and faucets from extremely high pressures on some city water systems.

Information on dump valve and black tank flush use can be found under DRAIN AND WASTE SYSTEM further back in this section

AIRSTREAM 390/395/396 XL OWNERS MANUAL 2002

GALLEY FAUCET, MOEN PURETOUCH®
1-800-374-6542

WATER FILTRATION SAFEGUARDS

Your Moen PureTouch® Filtering Faucet System integrates carbon block filtration technology designed by Culligan International into a faucet spout. This technology is fast and effective at reducing contaminants commonly found in water and is certified by NSF International. The PureTouch Filtering Faucet System and installation must comply with State and Local laws and regulations. To ensure optimal operation of your new Moen faucet, please read the following safeguards carefully.

MicroTech™ Filter Cartridges

- MicroTech filter cartridges will reduce:
 - Chlorine, Taste and Odor (MicroTech 5000, 3000, 1000)
 - Lead (MicroTech 5000,3000)
 - Cysts (Cryptosporidium, Giardia) (MicroTech 5000)*

*The contaminants removed or reduced by this filter are not necessarily in your water.
- Do not use with water that is microbiologically unsafe or of unknown quality without adequate disinfections before or after the system. Systems certified for cyst reduction may be used on disinfected waters that may contain filterable cysts.
- MicroTech filter cartridges are designed for replacement after dispensing 200 gallons of filtered water (approximately 3 months). Water conditions and usage may affect filter life and water taste.
- The electronic indicator will signal when filter replacement is necessary
- Use only MicroTech filter cartridges with the PureTouch Filtering Faucet System.
- Filter flow rate = .4-.5 gpm at rated pressure (20 p.s.i. min. – 125 p.s.i. max.).

Water Temperature

- Minimum/Maximum faucet operating temperature = 40 degrees – 150 degrees F
- **CAUTION: Do not filter water above 100 degrees F.**

MicroTech™ Filter Flushing Instructions

- New MicroTech Filter Cartridge: Allow cold water to run through a new filter for 5 minutes to flush out any loose carbon particles. Once these small black specks are washed out the filter is ready for use.
- Daily Use: Allow cold water to run through the filter for 10-15 seconds prior to first use. If the filter has not been used for two days, run cold water through the filter for 60 seconds prior to use.

Questions

- If you have any questions please call our toll-free help line:

1-800-BUY-MOEN

Monday through Friday	8:00 a.m. to 8:00 p.m.
Saturday	8:00 a.m. to 6:30 p.m.

AIRSTREAM 390/395/396 XL OWNERS MANUAL 2002

PARTS DESCRIPTION

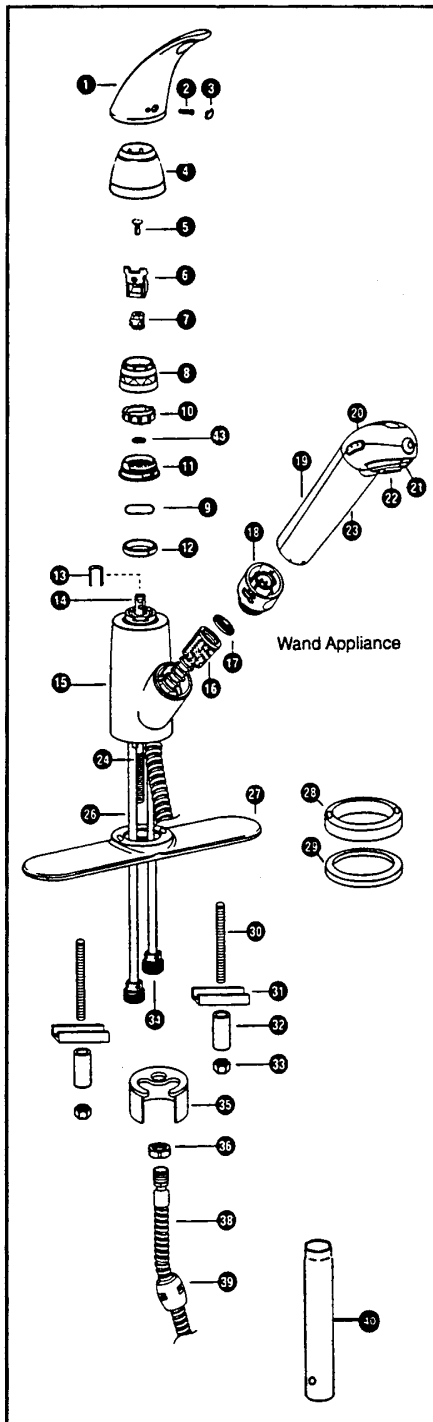

1. Solid Handle Body
2. Set Screw
3. Plug Button
4. Dome
5. Cartridge Screw
6. Handle Adapter
7. Handle Connector
8. Pivot Retainer
9. Wave Spring Washer
10. Pivot Stop
11. Retainer Nut
12. Bearing Washer
13. Retainer Clip
14. 1225 Cartridge
15. Spout Receptor
16. Hose Connection
17. Screen Washer
18. Quarter Turn Connector
19. Pull-out Spout
20. Upper Housing Unit
21. Filter Outlet Nut
22. Aerator
23. Filter Cover
24. Threaded Discharge Tube
25. Bottom Bearing Washer
26. Supply Tubes (2)
27. Deck Plate
28. Deck Ring
29. Ring Gasket
30. Deck Plate Studs (2)
31. Clamp Bar (2)
32. Spacer (2)
33. Small Mounting Nut (2)
34. 1/2" Threaded Fitting (2)
35. Mounting Bracket
36. Medium Mounting Nut
37. Adapter
38. Spout Hose
39. Counter Weight
40. Mounting Tool
41. Filter (not shown)
42. Large Mounting Nut (2) (not shown)
43. Washer

AIRSTREAM 390/395/396 XL OWNERS MANUAL

2002

OPERATING INSTRUCTIONS

Controlling The Water

The PureTouch System has three options for water delivery; unfiltered stream, unfiltered spray and filtered water.

The spray and stream actuating buttons are on the sides of the pullout spout; the filtered water button is located on the front of the spout.

Stream/Spray flow rate =
2.2gpm maximum at 60psi
2.5 gpm maximum at 80 psi.

STREAM MODE: Unfiltered water in regular stream flow.

When the water is turned on at the faucet, the spout will always begin operating in the regular stream mode.

SPRAY MODE: Unfiltered water in a wide pattern. If a wide spray mode is desired, push the spray button while the water is on. To return to stream mode, push the stream button.

FILTERED WATER MODE: Filtered water dispensed through the separate filtered water outlet. Pressing the front filtered water button will divert water through the filter and dispense filtered water from a separate outlet. The only way to exit the filter mode is to shut the faucet off.

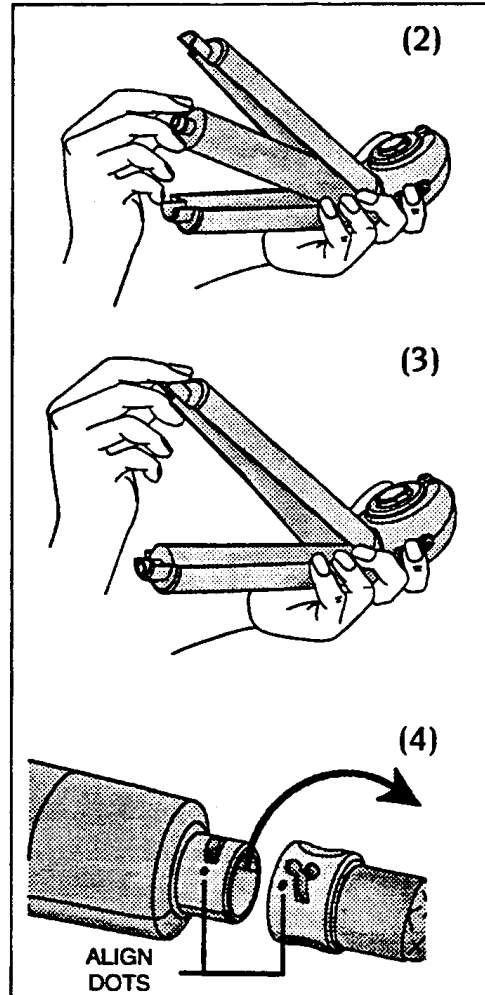

CAUTION: Only filter cold water. Do not filter water above 100 degrees F.

Electronic Indicator

The electronic indicator provides the following visual and audible feedback on the filtering system

- Successful installation of a new filter (audible & visual)
- Percent of filter life remaining (visual)
- Filter is actively filtering water (visual)
- Low filter warning (audible & visual)
- Depleted filter warning (audible & visual)
- Low battery warning (audible & visual)

The electronic indicator is powered by a replaceable standard 3V lithium watch battery (2032) designed to last several years.

AIRSTREAM 390/395/396 XL OWNERS MANUAL

2002

MICROTECH™ FILTER INSTALLATION

NOTE: Faucet will not operate in any mode without filter. Filter should be left in protective bag until ready for installation. The MicroTech™ filter is a high performance carbon block filter developed specially for the PureTouch Filtering Faucet System. **Once the filter is installed in the pullout spout, it should not be removed until it is to be replaced. The electronic module keeps track of the amount of filter life remaining and will signal you when the filter change is necessary. If a partially used filter is removed and reinstalled, the electronic indicator will automatically reset and will not accurately reflect filter life remaining.**

Use only Microtech filter cartridges with the PureTouch Filtering Faucet System.

1. Remove the filter cover by lifting it up and away from the pullout spout body.
2. Insert the new filter by aligning the outlet tubes on the filter with the inlet ports of the spout body and gently pressing in and down. Upon successful installation of the filter cartridge, the filter life indicator will beep three times and reset automatically. **(Do not remove the filter until it is to be replaced.)**
3. Re-install the filter cover by positioning the alignment tab with the corresponding notch in the main pullout spout body and gently pushing in and down.
4. Attach the pullout spout to the hose by aligning the dots on the quarter turn connector (18) and the spout. Push the quarter turn connector onto the spout assembly and turn it clockwise, locking it in place.
5. Allow cold water to run through the new filter for 5 minutes to flush out any loose carbon particles. Once these small black particles are washed out the filter is ready for use.

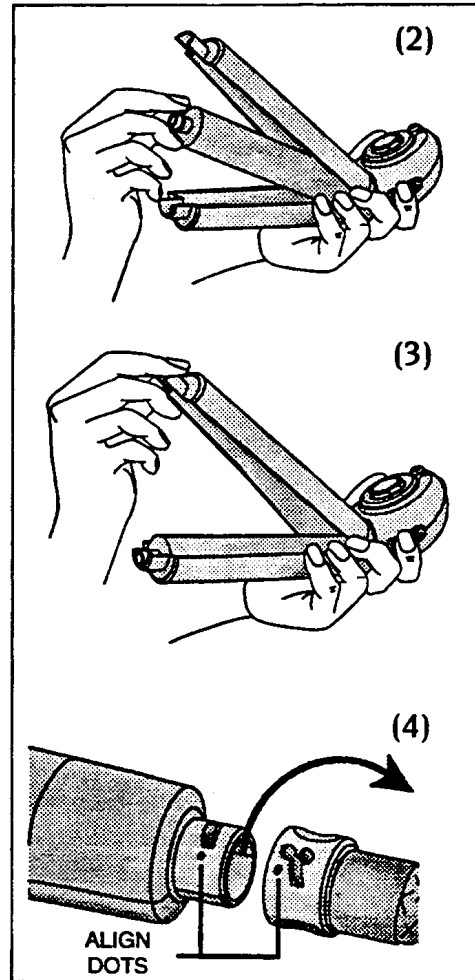

The PureTouch System installation is now complete. Please read carefully the operation instructions to ensure optimal performance.

CARE AND MAINTENANCE

All that is needed to clean your faucet is a soft damp cloth. Moen does not recommend the use of scour pads, cleansers or chemicals. The abrasive nature of these substances could damage the faucet's finish. A nonabrasive car wax will help to protect the finish. **DO NOT PLACE WAND APPLIANCE IN A DISHWASHER.**

AIRSTREAM 390/395/396 XL OWNERS MANUAL

2002

OPERATING INSTRUCTIONS

Successful Installation of a new Filter

When the depleted filter is replaced with a new filter three beeps are sounded and the 100% filter life is displayed momentarily. The new filter has been successfully installed and the electronic indicator has reset.

Percent of Filter Life Remaining

As the filter is used the indicator counts down to zero from 100%. The percentage remaining is displayed when water is being filtered. Additionally, the filter status can be checked without the faucet being turned on by momentarily pressing the filter button.

Filter is Actively Filtering Water

The water drop icon cycles when water is being filtered.

Low Filter Warning

There are two low filter warnings, one at 5% remaining filter life and 1% remaining life. When the remaining filter life reaches 5% the low filter icon blinks and three beeps are sounded when the filter button is depressed. At 1% or less the low filter icon blinks and beeps are sounded every 5 seconds while water is being filtered indicating it is time to change the filter.

Depleted Filter Warning

When the filter life remaining reaches 0%, the depleted filter icon blinks and beeps are continuously sounded while water is being filtered. The filter mode should not be used until a new filter is installed.

Low Battery Warning

A standard 3V lithium watch battery designed to last several years under normal usage powers the electronic indicator. When a low battery condition is detected the low battery icon blinks and beeps are sounded while water is being filtered indicating it is time to change the battery.

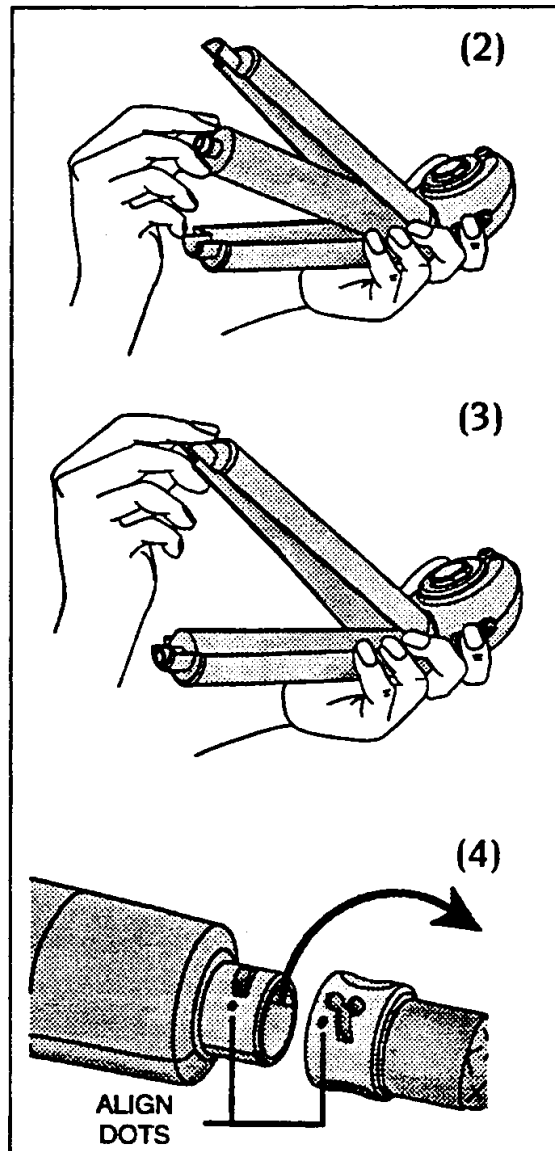

AIRSTREAM 390/395/396 XL OWNERS MANUAL

2002

OPERATING INSTRUCTIONS

Helpful Tools: large flat tip screwdriver, small Phillips screwdriver (#1).

Battery and Upper Housing Replacement

1. With faucet off, push filtered water button and record percentage of remaining usable filter life. When battery is changed, filter life indicator automatically resets to 100%. Record here _____.

2. Remove pullout spout (19) from receptor (15) and tie a dishtowel around the hose to keep it from slipping back into the spout receptor.

3. Disconnect the quarter turn connector (18) from spout by turning it counterclockwise one-quarter turn. The quarter turn connector will remain attached to the hose.

4. Remove filter cover by lifting up and away from main spout assembly. Remove filter cartridge from main spout assembly by lifting from the inlet tube, using same up and away motion. **NOTE: Excess water may dribble from cartridge and valving. Dry pullout spout with towel to prevent electronics from becoming wet.**

5. With large flat screwdriver or dime, unscrew (counterclockwise) and remove filter outlet nut (21).

6. With Phillips screwdriver unscrew (counterclockwise) and remove two short lower housing screws. Carefully remove lower housing cover.

7. Unscrew (counterclockwise) and remove three upper housing screws. Carefully lift upper housing cover off of wand appliance leaving rubber button covers in place.

8. Battery should now be exposed on upper side of spout. Remove old battery from battery compartment and dispose of properly.

9. Install new 2032 battery with positive side up. When battery is properly installed, filter life indicator will light momentarily. Activate electronic indicator by pressing filtered water button to ensure proper battery installation. Display should be visible.

10. Reinstall upper housing cover by carefully aligning over button covers.

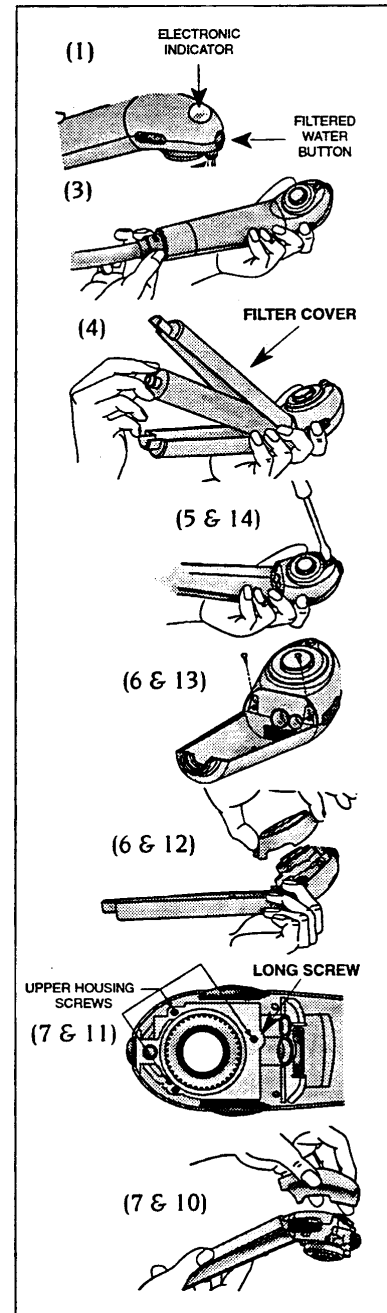

AIRSTREAM 390/395/396 XL OWNERS MANUAL

2002

NOTE: When reinstalling screws and filter outlet nut, insert into hole, turn counter clockwise with screwdriver until a click is felt then turn clockwise until snug. DO NOT OVER TIGHTEN!

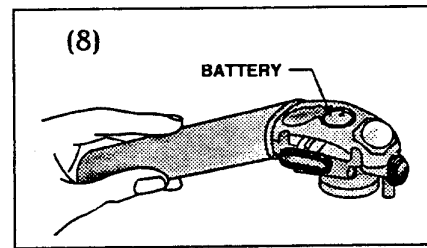

11. Reinstall 2 short and 1 long upper housing screws until snug. Refer to picture (7 & 11) on previous page for placement of long screw. **DO NOT OVER TIGHTEN!**

NOTE: To assist in aligning lower housing, press side buttons slightly while sliding housing in place.

12. Reinstall lower housing by carefully aligning over button covers.

13. Reinstall two short housing screws until snug. **DO NOT OVER TIGHTEN!**

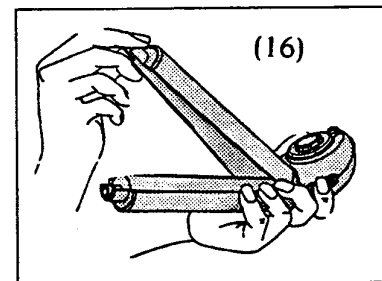

14. Reinstall filter outlet nut (21) with flat screwdriver. **DO NOT OVER TIGHTEN!**

15. Insert filter by aligning outlet tubes with inlet ports on main pullout spout assembly and gently pushing in and down. Upon successful installation of filter cartridge, pullout spout will emit a series of three beeps and filter life indicator will reset automatically.

16. Reinstall filter cover by positioning alignment tab over corresponding notch in main pullout spout assembly and gently pushing in and down.

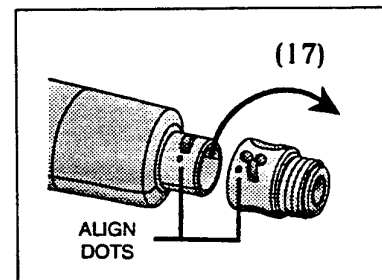

17. Reattach quarter turn connector (18) to pullout spout (19) aligning the dots on the quarter turn connector and the spout. Push the quarter turn connector onto the spout assembly and turn it clockwise, locking it in place. Return spout to the receptor.

18. If new filter was not installed at battery change, refer to remaining filter life previously recorded at beginning of battery replacement. Subtract recorded number in step I from the 100% displayed. The difference represents the display setting at which the current filter will need replacement. Filter may not perform as desired after this calculation percentage.

Example: Remaining filter life prior to battery change equals 30%.
Subtract 30% from 100% (100-30=70)
Filter will need to be changed when indicator reads 70%

AIRSTREAM 390/395/396 XL OWNERS MANUAL

2002

FILTER REPLACEMENT

MicroTech™ replacement filter cartridges may be purchased at the same location as the faucet. For the dealer nearest you, call 1-800-BUY-MOEN. Use only MicroTech filter cartridges with the PureTouch® Filtering Faucet System.

Do not remove the filter until it is to be replaced.

1. Remove pullout spout (19) from receptor (15) and tie a dishtowel around the hose to keep it from slipping back into the spout receptor.

2. Disconnect the quarter turn, connector (18) from pullout spout by turning it counterclockwise one-quarter turn. Quarter turn connector will remain on the hose.

3. Remove the filter cover by lifting up and away from pullout spout assembly. Remove the filter by lifting up and away from the pullout spout assembly. **NOTE: Excess water may dribble from cartridge and valving.**

4. Using soft towel or cloth, wipe excess water from wand appliance.

5. Insert the new filter by aligning the two outlet tubes on the filter with the two inlet ports on the spout body and gently pressing in and down. Upon successful installation of the filter cartridge, the pullout spout will beep three times and the filter life indicator will reset automatically.

6. Reinstall the filter cover by positioning the alignment tab with the corresponding notch in the main pullout spout body and gently pushing in and down.

7. Reattach the filtering pullout spout to the hose by aligning the dots on the quarter turn connector (18) to the pullout spout (19). Push the quarter turn connector onto the spout assembly and turn it clockwise locking it in place.

8. Allow water to run through the new filter for 5 minutes to flush out any loose carbon particles. After these small black particles are washed out the filter is ready to be used.

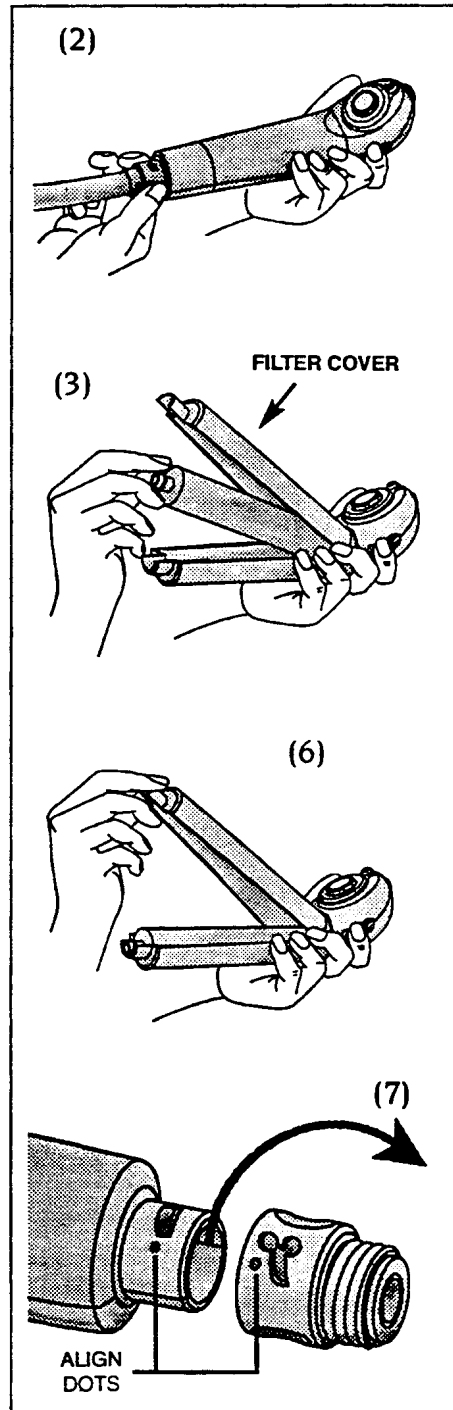

AIRSTREAM 390/395/396 XL OWNERS MANUAL

2002

TROUBLESHOOTING

PROBLEM: Water drips from hose and quarter turn connection

SOLUTION: Make sure screen washer (17) is in place.

PROBLEM: Slow or uneven water flow in unfiltered modes.

SOLUTION: The screen washer has become clogged. Ensure faucet handle is in a closed position. Remove pullout spout from receptor and tie a rag around the hose to keep it from slipping back into the spout receptor. Disconnect the quarter turn connector (18) from hose connection (16). Remove screen washer (17) from hose connection. Clean screen washer with a toothbrush and rinse.

PROBLEM: Reversed Hot & Cold positions.

SOLUTION: HELPFUL HINTS: IT IS NOT NECESSARY TO SHUT OFF WATER SUPPLIES. HANDLE SCREW REQUIRES A 7/16" HEX KEY WRENCH.

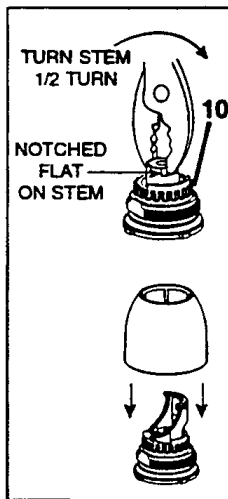

1. Remove plug button (3) from the handle by prying the button upwards from the bottom center. If a tool is required, use something which will not scratch the handle. Remove setscrew (2), handle body (1), dome (4), cartridge screw (5), handle adapter (6) and handle connector (7).

2. Turn cartridge stem around so that the notch is turned one half turn or 180 degrees.

3. Reinstall as follows: Be sure retainer clip (13) is present on cartridge stem and raised edge of pivot stop (10) faces front. Note orientation of handle adapter & connector assembly (6 & 7) in the exploded view. Completely turn cartridge screw (5) to prevent unwanted closure of faucet. Thread on dome clockwise until hand tight. Reinstall handle body (1), set screw (2) and plug button (3).

PROBLEM: Pullout hose does not move freely.

SOLUTION: Gently bend supply tubes away from the hose. DO NOT KINK SUPPLY TUBES

PROBLEM: Slow or uneven water flow in filtered mode.

SOLUTION: Filter outlet nut (21) may be clogged

1. Remove filter outlet nut, flush out carbon particles.
2. Filter cartridge may be clogged with captured contaminants Replace filter cartridge. If problem persists call Moen Help line at 1-800-BUY-MOEN.

PROBLEM: Water drains from sides of pullout spout when water is on

SOLUTION: Filter may be cracked. Replace filter.

PROBLEM: Electronic display doesn't function.

SOLUTION: Replace battery.

AIRSTREAM 390/395/396 XL OWNERS MANUAL
2002

MOEN FAUCET CARTRIDGE REPLACEMENT

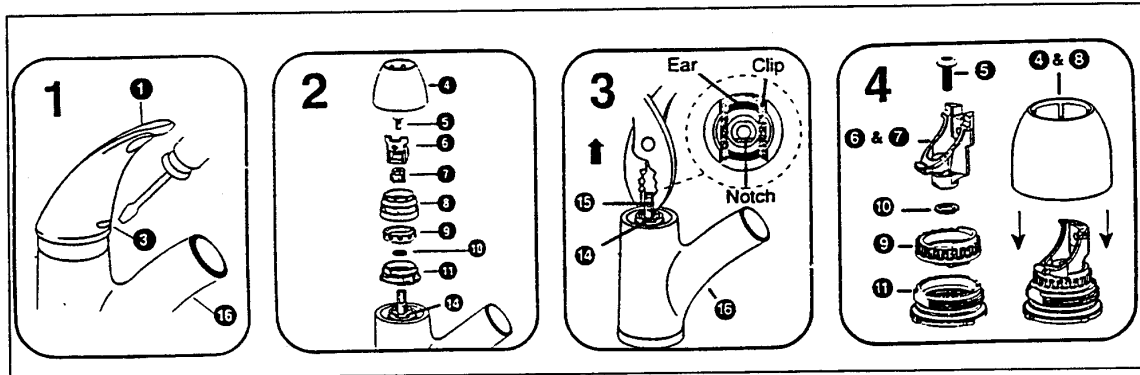

CAUTION: Always turn water OFF before removing existing faucet or disassembling the valve. Open faucet handle to relieve water pressure and ensure that complete water shut-off has been accomplished.

1. Remove plug button (3) from the handle by prying the button upwards from the bottom center. Be careful not to scratch the handle. Lift the handle up and using a 7/64" hex wrench, remove set screw (2). Remove handle (1), unscrew dome and pivot retainer (4 & 8), cartridge screw (5), handle adapter & connector assembly (6 & 7), and pivot stop (9). Remove DD washer (10) and retainer nut (11).

2. Using a flathead screwdriver, remove the retainer clip (14).

3. Grasp cartridge stem with pliers and pull cartridge (15) straight up and out of valve body.

4. Reinstall as follows: Install cartridge (15) into valve body with notched flat on stem facing forward. Be sure to position the ears of the cartridge in the front and back. Reinstall the retainer clip (14), which straddles the ears on the cartridge. Reinstall the retainer nut (11) and pivot stop (9) with the stop in front as shown in Step 4 above. Reinstall DD washer (10) and reassemble handle connector and handle adapter (6 & 7). Note orientation of this sub-assembly as shown in Step 4. Install cartridge screw (5). Be sure to install completely to prevent unwanted closure of faucet. Thread on dome and pivot retainer (4 & 8) clockwise until hand tight. Reinstall handle (1), set screw (2), and plug button (3).

AIRSTREAM 390/395/396 XL OWNERS MANUAL

2002

LAVATORY FAUCET, MOEN

DISASSEMBLY:

CAUTION: Turn OFF BOTH water supplies and open BOTH faucet handles to relieve water pressure and to insure that COMPLETE water shut off has been accomplished.

1. Remove handle cap or plug button (for Concentric handle models unscrew handle cap), handle screw, handle hub (insert handle adapter for Concentric models).
2. Loosen the cartridge nut with an adjustable wrench and remove it and the stem guide as a unit together with the upper handle adapter.
3. Set aside the cartridge nut and stem guide and with the handle adapter installed, reassemble handle hub (insert handle adapter for Concentric models) and handle screw and tighten.
4. Grasp the handle hub (insert handle adapter for Concentric models) and pull the cartridge STRAIGHT UP and out of the valve body.

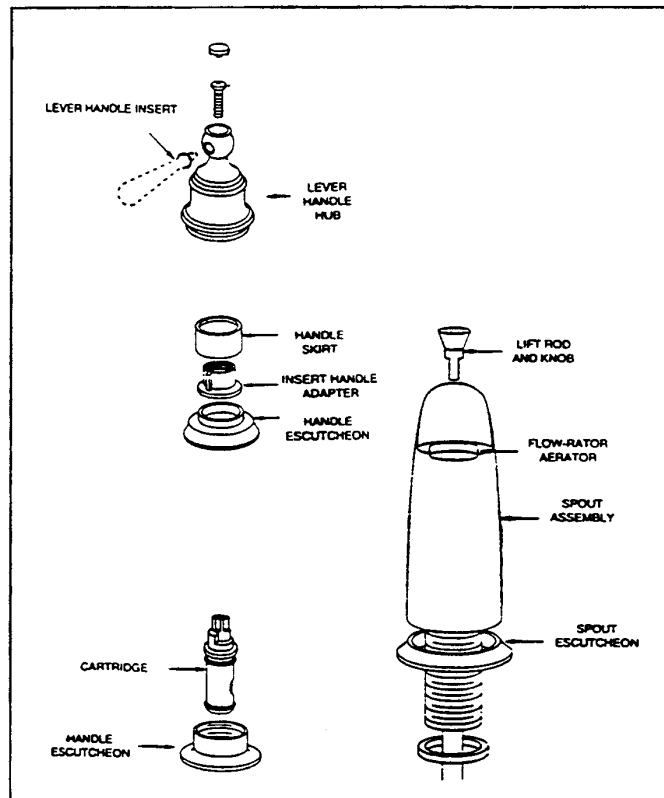

REASSEMBLY:

CAUTION: Failure to follow these instructions can cause personal injury or water damage to the premises, or could result in a faulty installation or damage the new cartridge.

1. Assemble upper and lower handle adapter and the handle hub (insert handle adapter for Concentric models) to new cartridge with the handle screw. Turn stem to the ON position, waterway holes in cartridge are lined up.
2. Insert the cartridge straight into the valve body, press firmly while rotating the handle hub (insert handle adapter for Concentric models) counterclockwise until you feel the key enter notch in the valve body. This will correctly position the cartridge. Turn handle knob in both directions to insure a stop in each direction.
3. Note handle rotation and orientation if adjustment is required.
4. Remove handle screw and handle hub (insert handle adapter for Concentric models), install cartridge nut with stem guide over the upper handle adapter, firmly tighten cartridge nut and stem guide using adjustable wrench.
5. Replace handle parts. Turn on water supplies.

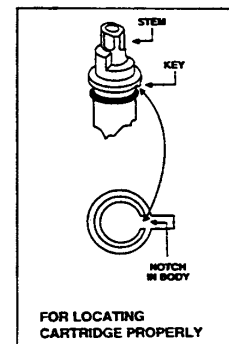

AIRSTREAM 390/395/396 XL OWNERS MANUAL

2002

MOEN SHOWER MIXING VALVE ASSEMBLY

1. Handle Cover
2. Handle
3. Cartridge
4. Handle Screw
5. Valve Body
6. Stop Tube
7. Retainer Clip

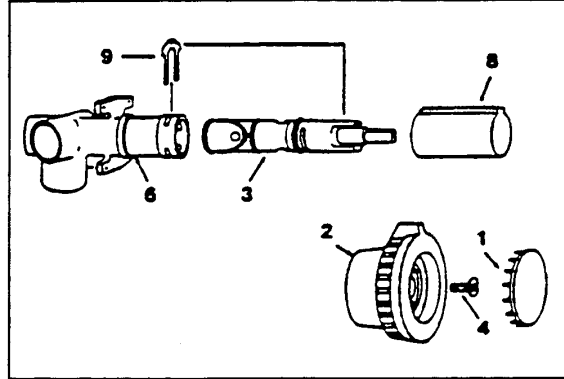

SHOWER MIXING VALVE CARTRIDGE REMOVAL

Shut off water pressure for entire system.

Disassemble: Remove handle cover. Take out handle screw and remove handle and stop tube. Lift out retaining clip and pull the cartridge out of the body by the stem.

CAUTION: Reinsert cartridge by pushing it all the way into the body and until the front of the ears on the cartridge shell are flush and aligned with the body. Replace the retainer clip so that the legs straddle the cartridge ears and slide down into the bottom slot in the body. This prevents the cartridge from rotating and locks it in the body. Reinstall stop tube and handle. Tighten handle screw securely, and replace the handle cover. The red flat on the stem must point UP when mounting the knob handle (down for lever handle).

If cold water is on left side and hot water is on right side (red flat pointed down), remove cartridge and reinstall 180°.

Removal and Replacement

1. Cover carpet and cover bottom of shower pan to protect them from damage.
2. Disconnect city water. Shut off water pump.
3. Open drain valves
4. Open galley, lavatory and shower faucets and allow water to drain from lines.
5. Remove screws from top of faucet inspection cover in wardrobe. Tip back and remove water lines from faucet.
6. Pop out metal insert in control valve handle. Remove screw and pull knob off.
7. Remove screws in escutcheon plate.
8. Disconnect shower hose.
9. Wrap masking tape on chrome fitting so as not to scratch chrome.
10. Using wrench, remove fitting.
11. Mixing valve, shower outlet, tube and hot and cold feed line assemblies may then be removed through wardrobe inspection hole.
12. Replace by reversing above procedure.

NOTE: If existing hose clamps were destroyed in removal, they should be replaced with screw type clamps.

AIRSTREAM 390/395/396 XL OWNERS MANUAL

2002

STORAGE

When storing your motorhome for a short or long period, use the same precautions as you would in your own home in regard to perishables, ventilation and rain protection. In addition, for a prolonged storage period, flush out all the drain lines and the holding tanks. Also, drain the entire water system, including the water heater and the water storage tank. Instructions for draining the water system are explained in the following paragraphs on winterizing.

Twice a year, or after a long storage period, we suggest you take your unit into your Airstream dealer for a check-up and cleaning of the gas operated appliances

WINTERIZING

The main consideration in winterizing is to guard against freezing damage to the hot and cold water systems, the waste drain system (including the traps), the waste holding tanks, the water heater and the batteries. To completely winterize your motorhome follow this procedure:

1. Level the motorhome from side to side and front to rear. Open all faucets.
2. Turn the water pump switch to the OFF position.
3. *Open the two drain line valves in your utility compartment as well as the exterior water faucet. Open the water tank drain valve also located in the utility compartment. Remove plug or open petcock on the exterior face of the water heater.
4. The toilet water valve should be left in open position while draining water. It is located in the lavatory cabinet.
5. While the water is draining from the system, depress the button on all hand spray heads and drain all water. Unscrew the head on spray unit and store.
6. After the water has stopped running from the drain lines, apply at least 60 lbs. of air pressure at the city water inlet. Be sure the toilet valve and all drain valves and faucets are open and pump outlet hose is disconnected. This can be accomplished at a service station and will force any remaining water from the water heater and remove any water which may be trapped in low areas.
7. Pour a cup of non-toxic antifreeze into the lavatory, sink, and tub drains to prevent freezing water in traps.
8. Be sure to open the waste holding tank drain valves, and drain and flush the tanks thoroughly. (This is very important, as the sewage in the tank, if frozen, could seriously damage the tank.)
9. Remove the batteries from your motorhome and store in a cool dry place where there is no danger of freezing. It is very important for optimum life of your battery to check it periodically and to keep it fully charged. This is especially true in winter months, when the temperature may drop below freezing. If the period of storage is for 30 days or less, you may turn off the "kill" switch rather than remove the batteries.
10. Remove any items (food, cosmetics, etc.) from the interior that might be damaged by freezing, or might damage the motorhome if containers break.

AIRSTREAM 390/395/396 XL OWNERS MANUAL

2002

For additional winterizing protection, add non-toxic antifreeze (approved for drinking water systems) to your water lines using the following procedure:

1. Reconnect all lines except the hose to the pump inlet port. Close all drain valves (See Step 3)

*2. Turn bypass valves to bypass position

3. Attach a length of hose to the pump inlet port. This piece of hose should be long enough for the free end to be inserted into and reach the bottom of the antifreeze container.

4. Dilute the antifreeze solution in accordance with the manufacturer's instructions.

5. Open all water faucets.

6. Insert hose length into the antifreeze container, turn the pump switch on, and run the water pump until the antifreeze solution fills all water lines. Flush toilet. Work shower hand spray while holding down in tub.

7. Shut off the pump and close all faucets.

8. Disconnect the hose length from pump inlet fitting and reconnect water system inlet line.

*To by-pass the water heater for winterizing, close valves A and C and open valve B (See illustration).

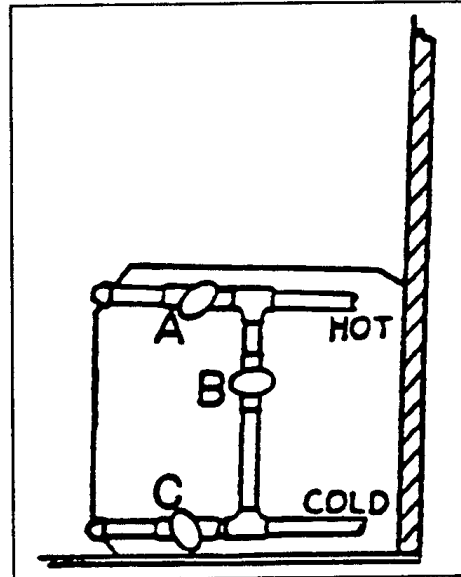

WINTERIZING YOUR OPTIONAL SPLENDIDE WASHER/DRYER

1. Turn off the hot and cold-water source to machine.
2. Set machine to fill with warm water in regular wash cycle, turn machine on for a few minutes so machine can take on any water left in inlet hoses. Make sure no water is left in inlet hoses.
3. Turn unit off and advance the wash timer to spin cycle and turn on. This will activate the water pump and will evacuate as much water as possible.
4. Turn unit off and remove wash filter. This will drain any water left in the bottom of unit. Make sure you get the drain filter put back in correctly or it may allow water to leak.
5. Turn valves to washer off and proceed with winterizing instructions on previous page.

Winterize Your Optional Icemaker

1. Remove the Airstream installed supply hose and the small clear Dometic supply water line from the solenoid located in the exterior refrigerated compartment. The solenoid is mounted to back of the refrigerator.
2. Drain the small clear hose and blow out and drain the solenoid and large water supply line.

AIRSTREAM 390/395/396 XL OWNERS MANUAL 2002

DRAIN AND WASTE SYSTEM

The drain and waste system of your motorhome includes waste holding tanks made from molded plastic. The MAIN HOLDING TANK enables you to use the toilet for several days away from disposal facilities. The wastewater from the sink, shower, and bath and lavatory drain into the AUXILIARY HOLDING TANK. Each tank has its own dump valve; however, both tanks drain through a common outlet. Therefore, you need to make only one connection when hooking up in a trailer park with sewer facilities.

Monitor Panel

Check your monitor panel frequently. When the MAIN HOLDING TANK (Tank1) is completely full, sewage cannot be emptied from the toilet bowl. If the AUXILIARY HOLDING TANK (Tank2) is overfilled, drain water will "backup" into the tub and cause an unpleasant cleaning job. Tank one on the monitor panel is the "black" tank and tank two is the auxiliary or "gray" tank. Never drain the tanks at any place other than an approved dumping station.

To empty both tanks, attach the sewer hose by pressing the bayonet fitting onto the outlet adapter and rotate clockwise until it feels solid and secure. Attach the outlet end of the hose to the sewage outlet; making sure that the hose is placed so that it will drain completely. The dump valves are located in the utility compartment on the roadside. Pull the dump valve handle out as far as it will go and wait until the tank is drained. If the auxiliary tank is drained after the waste tank, the soapy water will help keep the sewer hose and outlet clean.

When Parked and Connected to Sewer Outlet

When you are in a park and connected to a sewer outlet, keep the main holding tank dump valve closed and empty the tank every few days or whenever it becomes almost full. ONLY BY SENDING A LARGE VOLUME OF LIQUID THROUGH THE MAIN HOLDING TANK AT A TIME WILL TOILET PAPER AND OTHER SOLIDS COMPLETELY WASH AWAY.

This practice will avoid the accumulation of solids in the main holding tank, which could lead to an unpleasant cleaning job. Should solids accumulate, close the dump valve, fill the tank about half full with water, then drive the motorhome for a few miles. The turbulence and surging of the water will usually dissolve the solids into suspension so the tank can be drained. Keep the auxiliary tank valve open when connected to a sewer outlet.

Draining the tanks as described will protect them from freezing during storage. When traveling in sub-freezing temperatures, use a winterizing solution designed for RV use. Follow the directions on the container. As this is being written, heated tanks are being considered and may be on your motorhome.

CAUTION: Never put wet strength paper towels or tissues in your holding tank, since they won't dissolve and can "catch" in the mechanism of the dump valve. Colored toilet tissue is slower to dissolve than white. Most RV accessory stores offer tissue, designed for RVs that will completely dissolve.

AIRSTREAM 390/395/396 XL OWNERS MANUAL

2002

BLACK TANK FLUSH

The main holding tank must be flushed out until all paper and waste material is removed. Close the dump valve and refill the tank with 5 to 10 gallons of clean water and repeat until clean.

In the utility compartment on the left side is a water hose connector marked "black tank flush." To use, hook-up hose and turn on full force. Within the tank a spray head with a multiple-holed head will spray the interior surface of the tank.

The gate valve should be closed for the first couple of minutes, and then opened to let the water out in a rush. Repeat as needed.

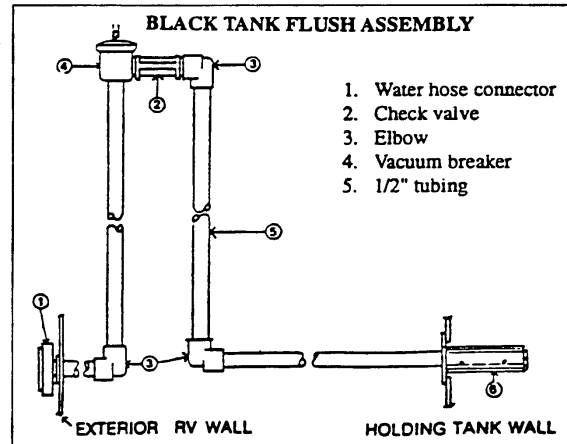

Drain Systems Cleaning

There are many deodorizers on the market in tablet, liquid, and powder form. These not only combat odor, but also, stimulate the bacteria that works to dissolve the solids in your tank. Picking a deodorizer with lubricating qualities will ease slide valve operation.

The only cleaning agents that can be used without causing harm to the system are household ammonia and tri-sodium phosphate in small quantities. Do not use any product that contains any portion of petroleum distillates. This attacks the rubber seals of your toilet and dump valve. Also, do not use any dish detergent or abrasive cleaners. All products should be marked approved for ABS drainage systems.

When winterizing drains use only recreational vehicle plumbing type antifreeze. These are sold through your dealer.

AIRSTREAM 390/395/396 XL OWNERS MANUAL

2002

TOILET

Manufacturer: Thetford Corporation
7101 Jackson Road
Ann Arbor, MI 48103
313-769-6000

The RV toilet in your Airstream is a design that has been used for many years. There are two pedals. The large pedal opens and closes the slide mechanism, and the smaller pedal opens and closes a water valve.

In normal use, when you are hooked up to city water, both pedals are depressed together. This dumps the sewage and fresh water and flushes down the side of the bowl. Water will continue to run into the bowl for a short time after the pedals are released.

When you wish to conserve water hold the hand-spray head over the bowl and hold down the thumb-operated lever. Now when you depress the pedal all the water is routed through the hand-spray.

CAUTION: When you dump the bowl of the toilet make sure all paper and solids have cleared the slide mechanism before you allow it to close. Failure to do so can cause the groove for the slide to become jammed and the slide will no longer close completely.

If the problem should occur a small nail or bent clothes hanger can be used to "pick" the material out of the groove.

AIRSTREAM 390/395/396 XL OWNERS MANUAL

2002

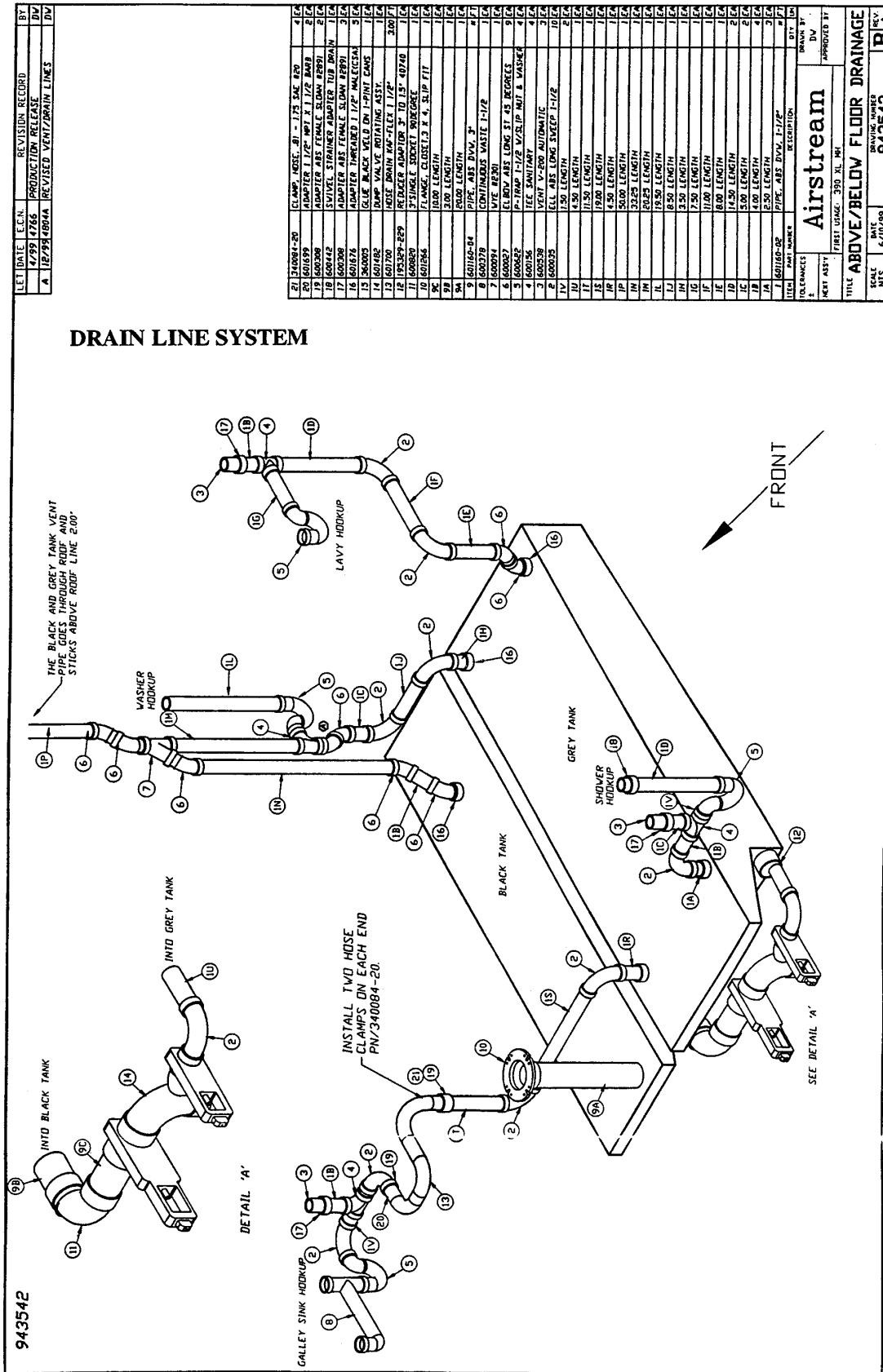

REV	DATE	BY	DESCRIPTION
1	12/23/00	BY	REVISION RECORD
2	1/18/01	BY	PRODUCTION RELEASE
3	1/18/01	BY	REVISED VENT/DRAIN LINES

ITEM	QTY	DESCRIPTION	REV
1	1	CLAMP HOSE, 3/4" I.D. SAE STD	1
2	1	ELBOW ABS FEMALE SLANG 90°	1
3	1	ADAPTER ABS FEMALE SLANG 90°	1
4	1	ADAPTER ABS FEMALE SLANG 90°	1
5	1	SWIVEL STRAINER ADAPTER TUB 1/2"	1
6	1	ADAPTER ABS FEMALE SLANG 90°	1
7	1	ADAPTER IMPAIRED 1/2" MALE/CSA	1
8	1	GLUE BLACK WELD ON 1-PINT CAN	1
9	1	DAMP VALVE ROTATING ASSY.	1
10	1	HOSE DRAIN 1/2" X 1/2" 40' 40' 40'	1
11	1	REDUCER ADAPTER 3" TO 1 1/2"	1
12	1	3/4" SINGLE SOCKET 90 DEGREE	1
13	1	1/2" SINGLE SOCKET 90 DEGREE	1
14	1	1/2" SINGLE SOCKET 90 DEGREE	1
15	1	1/2" SINGLE SOCKET 90 DEGREE	1
16	1	1/2" SINGLE SOCKET 90 DEGREE	1
17	1	1/2" SINGLE SOCKET 90 DEGREE	1
18	1	1/2" SINGLE SOCKET 90 DEGREE	1
19	1	1/2" SINGLE SOCKET 90 DEGREE	1
20	1	1/2" SINGLE SOCKET 90 DEGREE	1
21	1	1/2" SINGLE SOCKET 90 DEGREE	1

Airstream FIRST USAGE: 390 XL MKI		APPROVED BY DW
TITLE: ABOVE/BELOW FLOOR DRAINAGE		DRAWING NUMBER: 943542
SCALE: NTS	DATE: 6/10/99	REV: B1

AIRSTREAM 390/395/396 XL OWNERS MANUAL

2002

ELECTRICAL SYSTEM **12-VOLT SYSTEM** **BATTERY CONTROL CENTER**

Your motorhome is equipped with six batteries. Two batteries will be for the engine and the other 4 batteries for the interior 12-volt circuits on a rollout tray.

The Intellitec Battery Control Center is a centralized power switching, fusing, and distribution center. Power from both the chassis and the coach batteries are feed into the control center box. **All servicing with-in this box should be done only by a qualified Service Technician.**

BATTERY DISCONNECT SWITCH

The BATTERY DISCONNECT switch on the panel just inside the main door acts as a master switch. When the coach switch is turned to **use** it opens the circuit between the coach batteries and the twelve-volt distribution panel. The chassis disconnect switch does not disconnect the chassis battery from the chassis systems. It only cuts off power from the inverter/charger charging system to the chassis battery. You must have the chassis battery disconnect switch on (**use**) for the inverter/converter to charge the engine batteries. The coach batteries are charged by the inverter/converter whether the coach battery disconnect switch is in the use or store position.

The engine batteries are used for starting the engine and operating the headlights, taillights, running lights, instrument panel lighting, automotive air conditioning and other accessories. The alternator charges all the batteries while the engine is running. The inverter/converter charges all the batteries when the unit is plugged into shoreline as long as the chassis battery disconnect switch is on (**USE**).

The coach batteries are used for interior lighting; exhaust fans, generator, water pump, central control panel, entertainment center, optional 12-volt convenience outlets, and the refrigerator when it is switched to 12-volt power. The generator also charges all batteries when it is running, through the 120-volt city power system that powers the inverter/converter. The Intellitec Battery Control Center manual is also in your packet. It has trouble-shooting and wiring information.

The battery disconnect switch is not intended for everyday use. But if you're going to be away from your coach for more than 3 or 4 days and it's not plugged into 110-volt current just flip the switch off on the way out and your assured of fresh batteries when you return.

Inverter

With the inverter is the standard package of four batteries for the interior coach circuits. The inverter is located in the second lower compartment back of the main door. An inverter uses 12-volt battery power and changes it to 120 volt AC current. More information on the 120 volt operation is in the II 0 volt section of this manual.

What is important on the 12-volt side is the amount of power required from the batteries for the inverter. This is probably best shown by a little ninth grade science.

120-volt (Plugged in)	12-volt (Battery power)
$\frac{1500 \text{ Watt}}{120 \text{ Volt}} = 12.5 \text{ amp}$	$\frac{1500 \text{ Watt}}{12 \text{ Volt}} = 125 \text{ amp}$

Pulling 125 amps from your batteries is a tremendous load. Luckily there would probably be few times where you need this kind of power. If you do need 1500 watts for an extended period of time start your generator --- 1500 watts would be a light load for it.

A little common sense will make the inverter system useful. But, if you try to overdo it you'll have dead batteries.

AIRSTREAM 390/395/396 XL OWNERS MANUAL

2002

12-Volt Operation

The only thing you have to do is make sure the coach batteries don't run down. In normal usage there isn't any problem, since you would normally drive part of the day and be plugged into a campground at night. The alternator charges the batteries when you drive and when you're plugged into city power the converter charges the batteries and carries much of the load.

Some nights you may not find a place to plug into city power. No problem, the standard battery system gives you about 400 amp-hours so you can comfortably run your lights and vents in a normal fashion without depleting the batteries.

If you are not plugged into city power and you're not driving, you'll want to conserve your batteries by using as few lights and appliances as possible. If you notice the lights becoming dim, it's much easier on the batteries if you go ahead and start the engine or generator before the batteries run down.

Your motorhome is equipped with a 10-watt solar panel. There is an indicator light to the left of the microwave that is on when there is enough sunlight to have a charging condition.

There are two sets of 12-volt fuses and breakers in your motorhome. The main interior circuits are in the foot of the bed behind an access door. The brightly colored fuses pull straight out from the face of the panel. Replacement fuses are available at automotive stores and most service stations. On the panel covering the fuses is a diagram showing the function of each fuse or circuit breaker.

The chassis manufacturer provides the second set of fuses. Freightliner fuses are located in the lower compartment forward of the roadside front wheel.

Many interior lights have been included in your motorhome to give you almost infinite variable light intensity.

Just inside the main door are switches for the step, patio light, aux. Batt (390 only), and forward ceiling lights. The forward ceiling lights must have their switches on before the remote switch on the panel will control them.

The reading lamps above the sofa, dinette, recliners, galley indirect lighting, are operated by the two gang switches located on the wall above the deluxe sofa and on the wall forward of the dinette. The wall and hanging lamps are operated by the dimmer switches on the wall.

The two-gang switch on the galley slide-out panel below the monitor system operates the china cabinet light above the galley and the ceiling lights.

In the bathroom the water heater switch supplies power to the igniter and gas valve. When turned on, it will flash red until flame is sensed, then the red light will be extinguished. The other switches above the lavatory operate the shower, lower medicine cabinet, bath mirror lights and water pump.

The switch in front of the bed wardrobe and a switch above the bed headboard on the curbside operate the bedroom ceiling lights. The switch besides the ceiling light switch operates beds reading lights. Individual switches located on the wall lamps are used for these lights.

The bulbs in the interior lights are all easily replaced if they burn out. Round, exposed bulbs, such as those around the bathroom mirror and reading lights, are replaced by depressing them into their base, then turning to the left about 1/4 turn. This will allow them to "pop" out part way, so they can be removed. Twelve-volt bulbs with flat bases pull straight out of their socket.

AIRSTREAM 390/395/396 XL OWNERS MANUAL

2002

To gain access to the bulbs in the round reading lights recessed in the bottom of the overhead lockers you must remove the lens. The lenses are removed by turning counterclockwise about half a turn. The bulb, like other flat base bulbs, pulls straight out of the socket.



WARNING: If they are difficult to turn, use a folded rag to protect your hand when grasping the bulb in case it should unexpectedly shatter.

The ceiling and wardrobe light lenses are removed by squeezing the sides of the lens in until they clear the frame. In cold weather it is helpful to leave the light on for a while to soften the plastic and avoid cracking. Incandescent bulbs are removed by depressing and turning to the left about 1/4 turn. Fluorescent bulbs are removed by turning in either direction.

Basic 12V Wiring

On the following pages are 12-volt wiring diagrams. The first drawing simply labeled "12V Wiring" will probably be the most useful. It shows how the power from the batteries reaches the main components.

All the batteries are located in a lower compartment behind the curbside rear wheels.

12V WIRING DIAGRAMS

12-Volt wiring main	Harness, A pillar	Harness, ceiling - A
Harness, headlight	Harness, switches, armrest	Harness, ceiling - B
Harness, firewall	Harness, clearance lights	Harness, tail light extension
Harness, chassis components	Harness, body, interior – A	Harness, taillight
Harness, body, chassis – A	Harness, body, interior – B	Harness, rear clearance lights
Harness, body, chassis – B	Harness, body, upper	Wiring, exterior mirrors
	Wiring, slide-out room relays	Wiring, keyless entry

AIRSTREAM 390/395/396 XL OWNERS MANUAL

2002

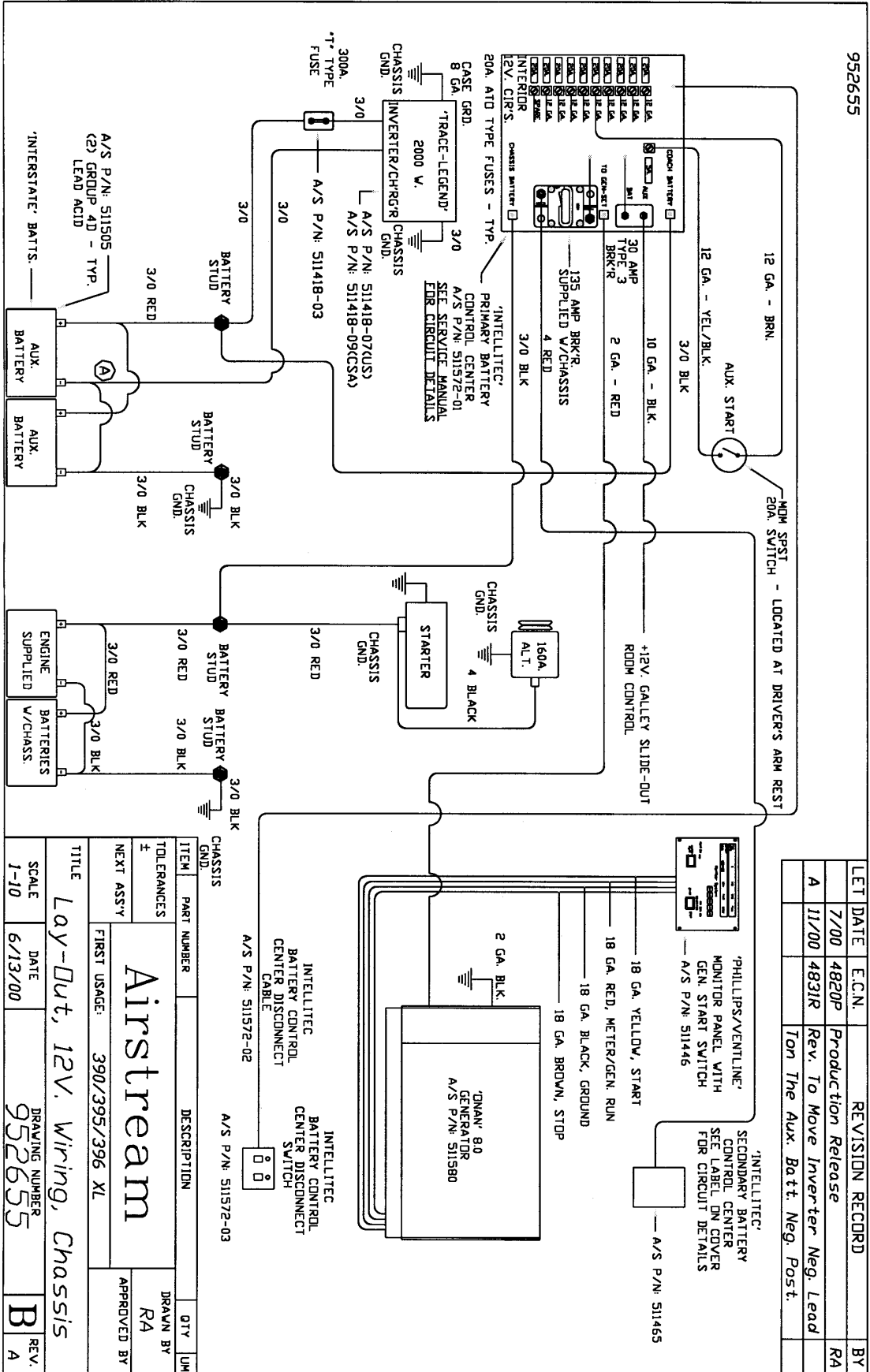

AIRSTREAM 390/395/396 XL OWNERS MANUAL

2002

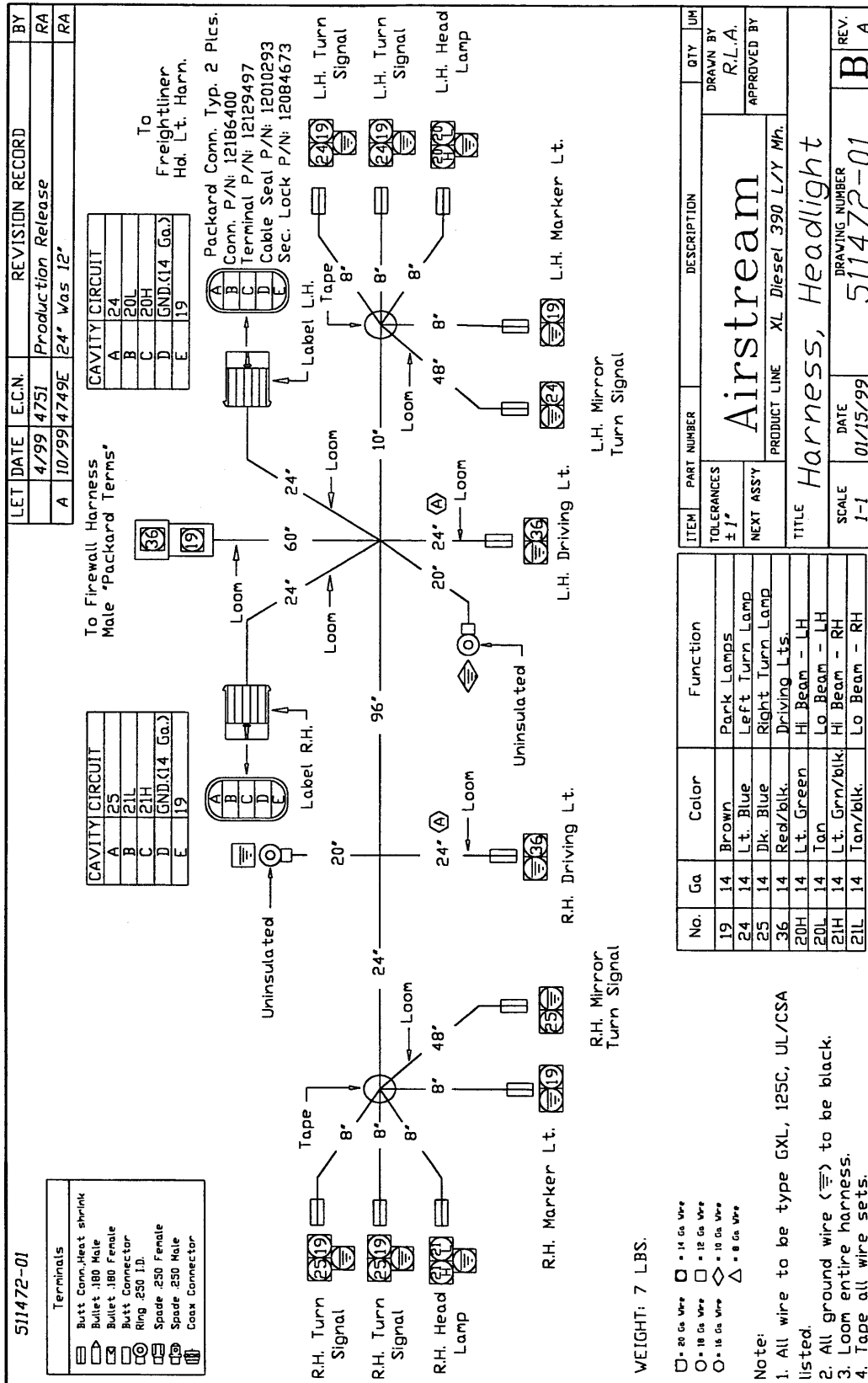

AIRSTREAM 390/395/396 XL OWNERS MANUAL

2002

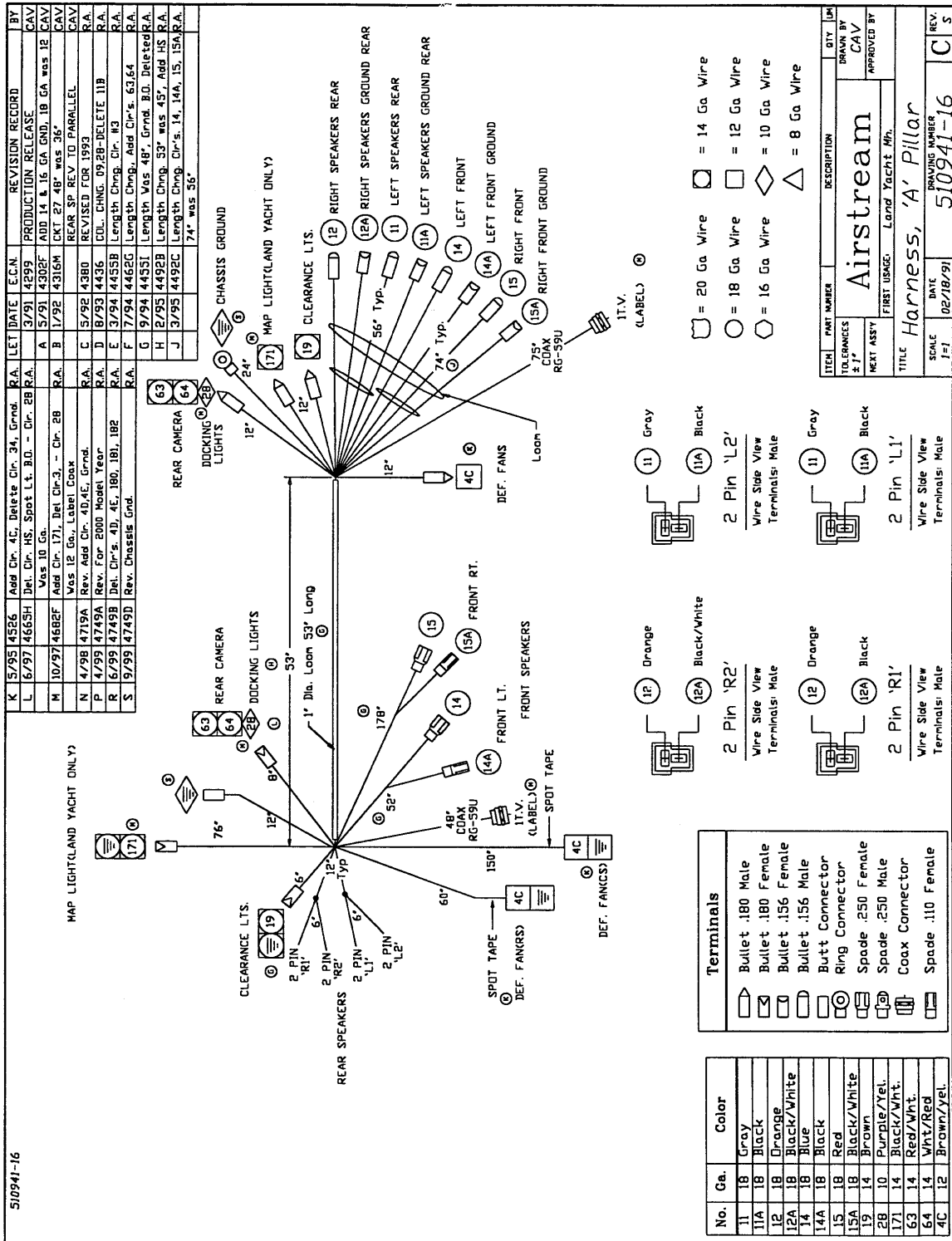

AIRSTREAM 390/395/396 XL OWNERS MANUAL

2002

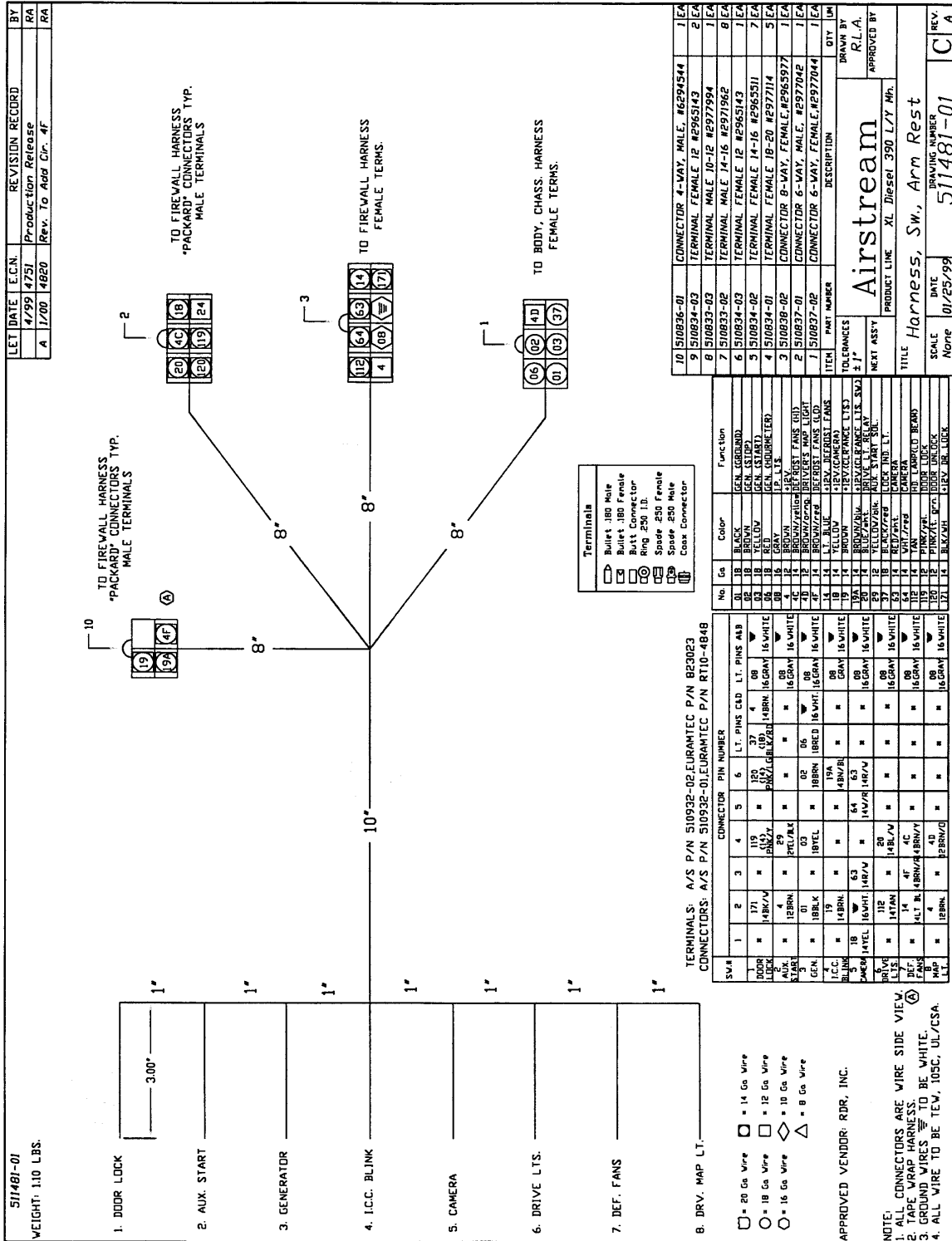

AIRSTREAM 390/395/396 XL OWNERS MANUAL

2002

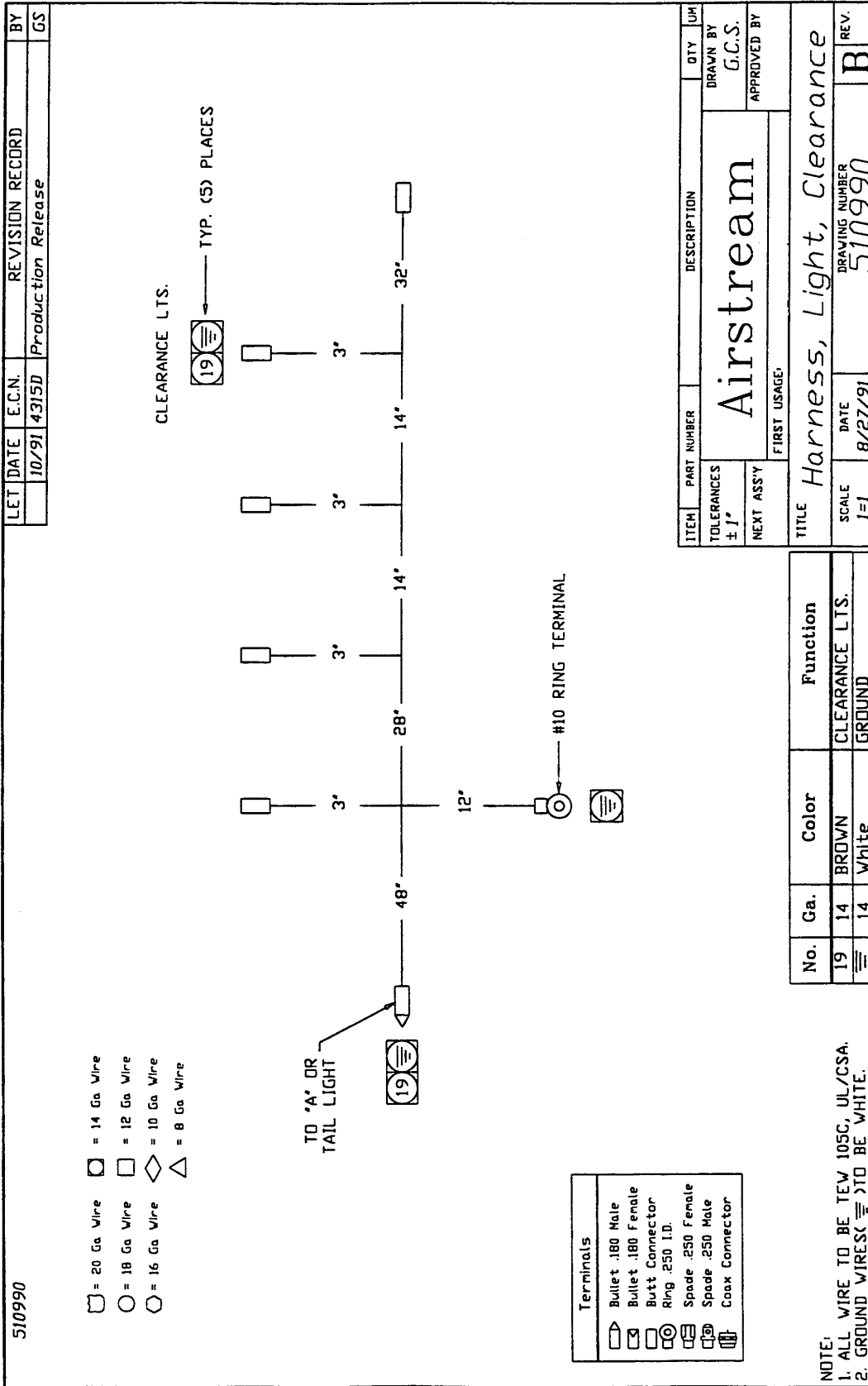

AIRSTREAM 390/395/396 XL OWNERS MANUAL

2002

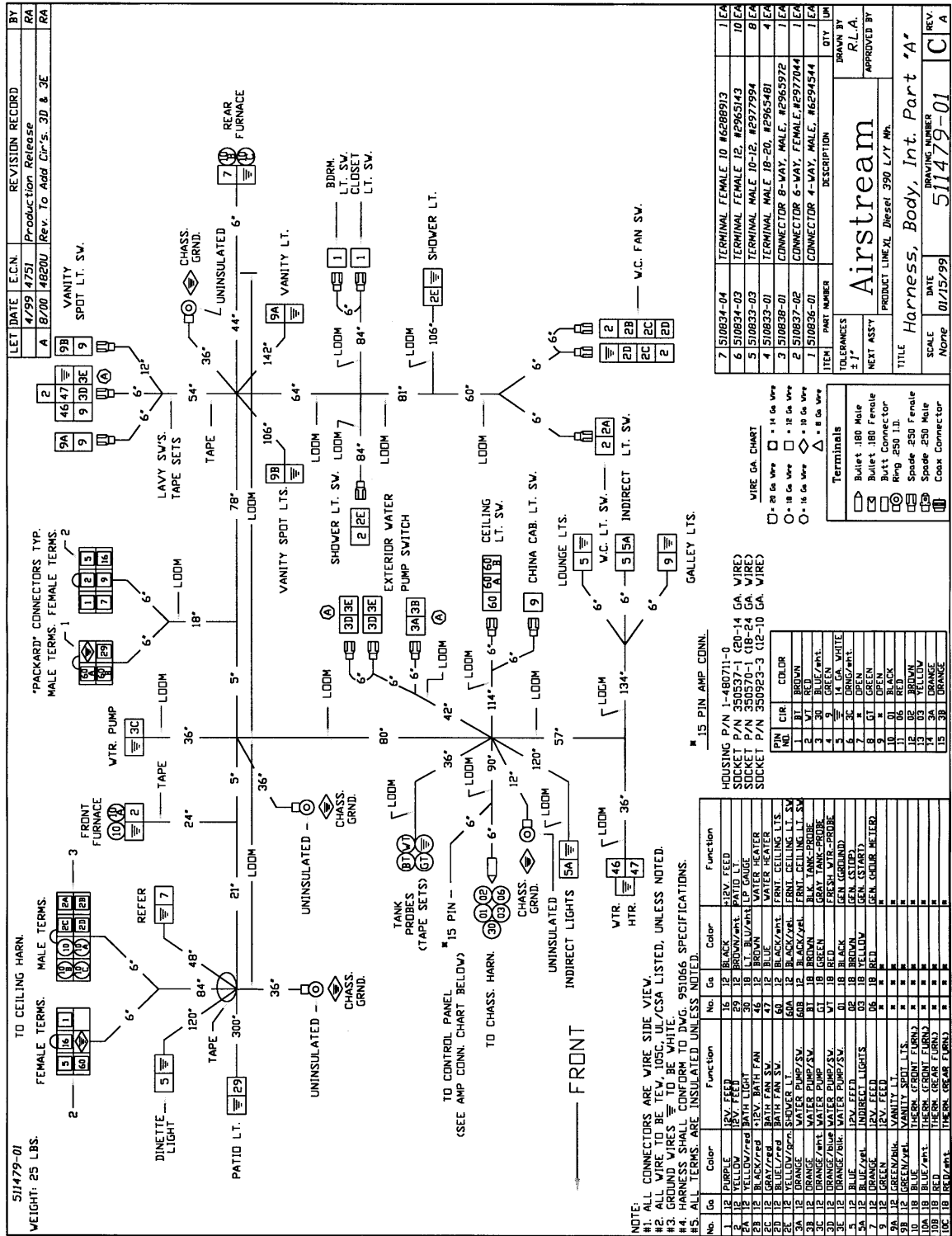

AIRSTREAM 390/395/396 XL OWNERS MANUAL

2002

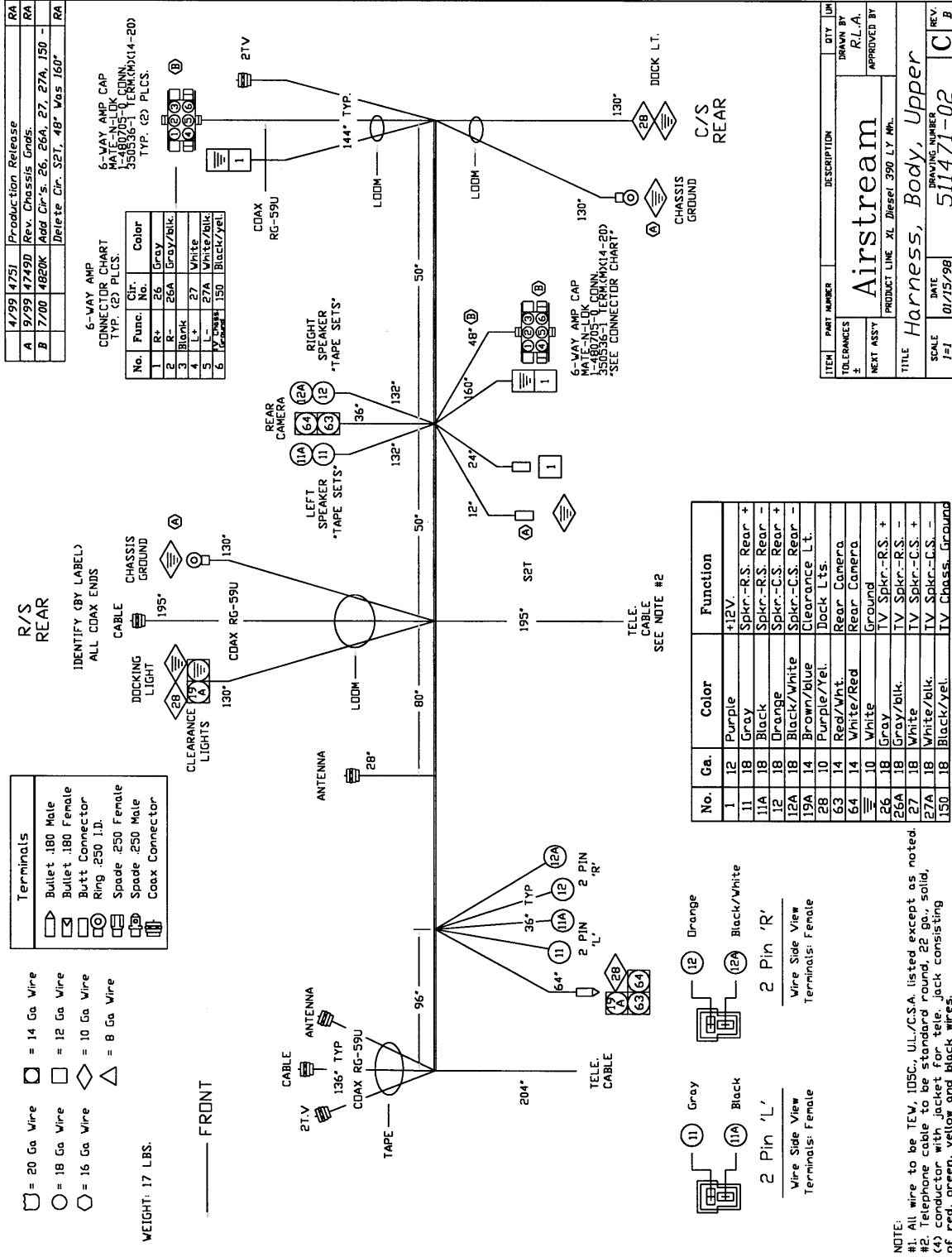

AIRSTREAM 390/395/396 XL OWNERS MANUAL

2002

LET	DATE	E.C.N.	REVISION	REV.	BY
A	9/99	4749D	12" Was 6"		RA
			Production Release		RA

CURBSIDE

511516-01

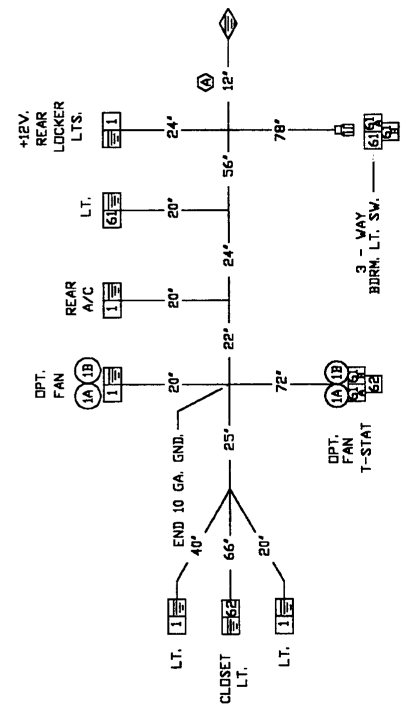

FRONT

□	= 20 Ga. Wire	□	= 14 Ga. Wire
○	= 18 Ga. Wire	□	= 12 Ga. Wire
○	= 16 Ga. Wire	◇	= 10 Ga. Wire
		△	= 8 Ga. Wire

WEIGHT: 14 LBS.

- NOTE:
- #1. ALL CONNECTORS ARE WIRE SIDE VIEW.
 - #2. WIRE SHALL BE 100% PVC/CSA LISTED.
 - #3. COLOR SHALL BE WHITE.
 - #4. HARNESS SHALL CONFORM TO DVG. 951066 SPECIFICATIONS.
 - #5. STAGGER SPLICES-DIA. OF WIRE BUNDLE SHOULD NOT EXCEED .43 IN.
 - #6. ALL TERMINALS ARE INSULATED UNLESS NOTED.

No.	Ga.	Color	Function
1	12	Purple	+12V.
1A	18	Green/wht.	Dpt. Barn. Fan
1B	18	Green/wht.	Dpt. Barn. Fan
6	12	Purple/wht.	Barn. Ceiling L.T.
6A	12	Purple/wht.	Barn. Ceiling L.T. SW
6B	12	Purple/wht.	Barn. Ceiling L.T. SW
6C	12	Purple/wht.	Barn. Ceiling L.T. SW
6D	12	Purple/wht.	Barn. Ceiling L.T. SW
6E	12	Purple/wht.	Barn. Ceiling L.T. SW
6F	12	Purple/wht.	Barn. Ceiling L.T. SW
6G	12	Purple/wht.	Barn. Ceiling L.T. SW
6H	12	Purple/wht.	Barn. Ceiling L.T. SW
6I	12	Purple/wht.	Barn. Ceiling L.T. SW
6J	12	Purple/wht.	Barn. Ceiling L.T. SW
6K	12	Purple/wht.	Barn. Ceiling L.T. SW
6L	12	Purple/wht.	Barn. Ceiling L.T. SW
6M	12	Purple/wht.	Barn. Ceiling L.T. SW
6N	12	Purple/wht.	Barn. Ceiling L.T. SW
6O	12	Purple/wht.	Barn. Ceiling L.T. SW
6P	12	Purple/wht.	Barn. Ceiling L.T. SW

□	Emergency Connector
□	Splice
□	Splice
□	Splice
□	Bullet 100 Male
□	Bullet 100 Female
□	Bull Connector
□	Ang. 250 Lin.
□	Splice
□	Splice
□	Splice
□	Coat Connector

ITEM	PART NUMBER	DESCRIPTION	QTY	UN
TOLERANCES	Airstream		DRAWN BY R.L.A.	
NEAT ASBY	PRODUCT LINE XL Diesel 390 L/Y Mh.		APPROVED BY	
TITLE	Harness, Ceiling, Part 'B'			
SCALE	None	DATE	05/18/99	DRAWING NUMBER
				511516-01
				REV. A

AIRSTREAM 390/395/396 XL OWNERS MANUAL

2002

511263-01

LET DATE	E.C.N.	REVISION RECORD	BY
7/95	4526A	Production Release	RA
8/98	4736	Rev. Chass/Tail Lt. Harn. Conn.	RA

CHASS. CONN. METRI PACK(MALE) - 280 SERIES
PACKARD-ELEC. P/N: 12110753

MALE TERMS. PACKARD-ELEC. P/N: 12129497

TERMINAL SEAL PACKARD-ELEC. P/N: 12110752

SECONDARY LOCK PACKARD-ELEC. P/N: 12110754

A/S P/N: 510863-02
Vendor P/N: Wire Design, A30-403

ITEM	PART NUMBER	DESCRIPTION	QTY	UM
11	510833-03	TERMINAL MALE 10-12 #2977994	2	EA
10	600287-50	LODM,CNVLT POLYE-SLIT 1/2 ID	5	FT
9	510863-02	PLUG BLY MH I.LITE HARN 510863	1	EA
8	511219-06	WIRE 14GA GXL WHITE	4	FT
7	511219-12	WIRE 14GA GXL 125C LT. GREEN	4	FT
6	511219-10	WIRE 14GA GXL 125C RED/YELLOW	4	FT
5	511219-07	WIRE 14GA GXL 125C GREEN	4	FT
4	511219-04	WIRE 14GA GXL 125C BRDWN	4	FT
3	511219-02	WIRE 14GA GXL 125C YELLOW	4	FT
2	510833-02	TERMINAL MALE 14-16 #2971962	5	EA
1	510838-01	CONNECTOR B-WAY, MALE, #2965972	1	EA

Wire Gauge Chart

□	= 20 Ga Wire	○	= 14 Ga Wire
○	= 18 Ga Wire	□	= 12 Ga Wire
◇	= 16 Ga Wire	◇	= 10 Ga Wire
△	= 8 Ga Wire		

Terminals

Heat-Shrink Butt
Bullet .180 Male
Bullet .180 Female
Ring 250 I.D.
Spade 250 Male
Spade 250 Female
Coax Connector

Wire Gauge Chart

No.	Ga	Color	Function
38	14	Red/Yellow	Center Brake Lt.
19	12	Brown	Clearance Lts.
20	14	Dk. Blue	Tail Lts.
24	14	Yellow	Left Turn Lt.
25	14	Dk. Green	Rt. Turn Lt.
27	14	Lt. Green	Back-Up Lts.
28	12	White	Ground
29	12	White	Ground
30	12	White	Ground
31	12	White	Ground
32	12	White	Ground
33	12	White	Ground
34	12	White	Ground
35	12	White	Ground
36	12	White	Ground
37	12	White	Ground
39	12	White	Ground
40	12	White	Ground
41	12	White	Ground
42	12	White	Ground
43	12	White	Ground
44	12	White	Ground
45	12	White	Ground
46	12	White	Ground
47	12	White	Ground
48	12	White	Ground
49	12	White	Ground
50	12	White	Ground
51	12	White	Ground
52	12	White	Ground
53	12	White	Ground
54	12	White	Ground
55	12	White	Ground
56	12	White	Ground
57	12	White	Ground
58	12	White	Ground
59	12	White	Ground
60	12	White	Ground
61	12	White	Ground
62	12	White	Ground
63	12	White	Ground
64	12	White	Ground
65	12	White	Ground
66	12	White	Ground
67	12	White	Ground
68	12	White	Ground
69	12	White	Ground
70	12	White	Ground
71	12	White	Ground
72	12	White	Ground
73	12	White	Ground
74	12	White	Ground
75	12	White	Ground
76	12	White	Ground
77	12	White	Ground
78	12	White	Ground
79	12	White	Ground
80	12	White	Ground
81	12	White	Ground
82	12	White	Ground
83	12	White	Ground
84	12	White	Ground
85	12	White	Ground
86	12	White	Ground
87	12	White	Ground
88	12	White	Ground
89	12	White	Ground
90	12	White	Ground
91	12	White	Ground
92	12	White	Ground
93	12	White	Ground
94	12	White	Ground
95	12	White	Ground
96	12	White	Ground
97	12	White	Ground
98	12	White	Ground
99	12	White	Ground
100	12	White	Ground

NOTE:

- ALL CONNECTORS ARE WIRE SIDE VIEW.
- ALL WIRE TO BE GXL 125C, UNLESS NOTED.
- LODM ENTIRE HARNESS.
- GROUND WIRES () TO BE WHITE.

Wire Gauge Chart

TOLERANCES	±	±	±
± 1/16"	± 1/16"	± 1/16"	± 1/16"

Airstream

PRODUCT LINE

Scale 1-2

Date 07/10/95

Drawing Number 511263-01

Rev. B

Rev. A

AIRSTREAM 390/395/396 XL OWNERS MANUAL

2002

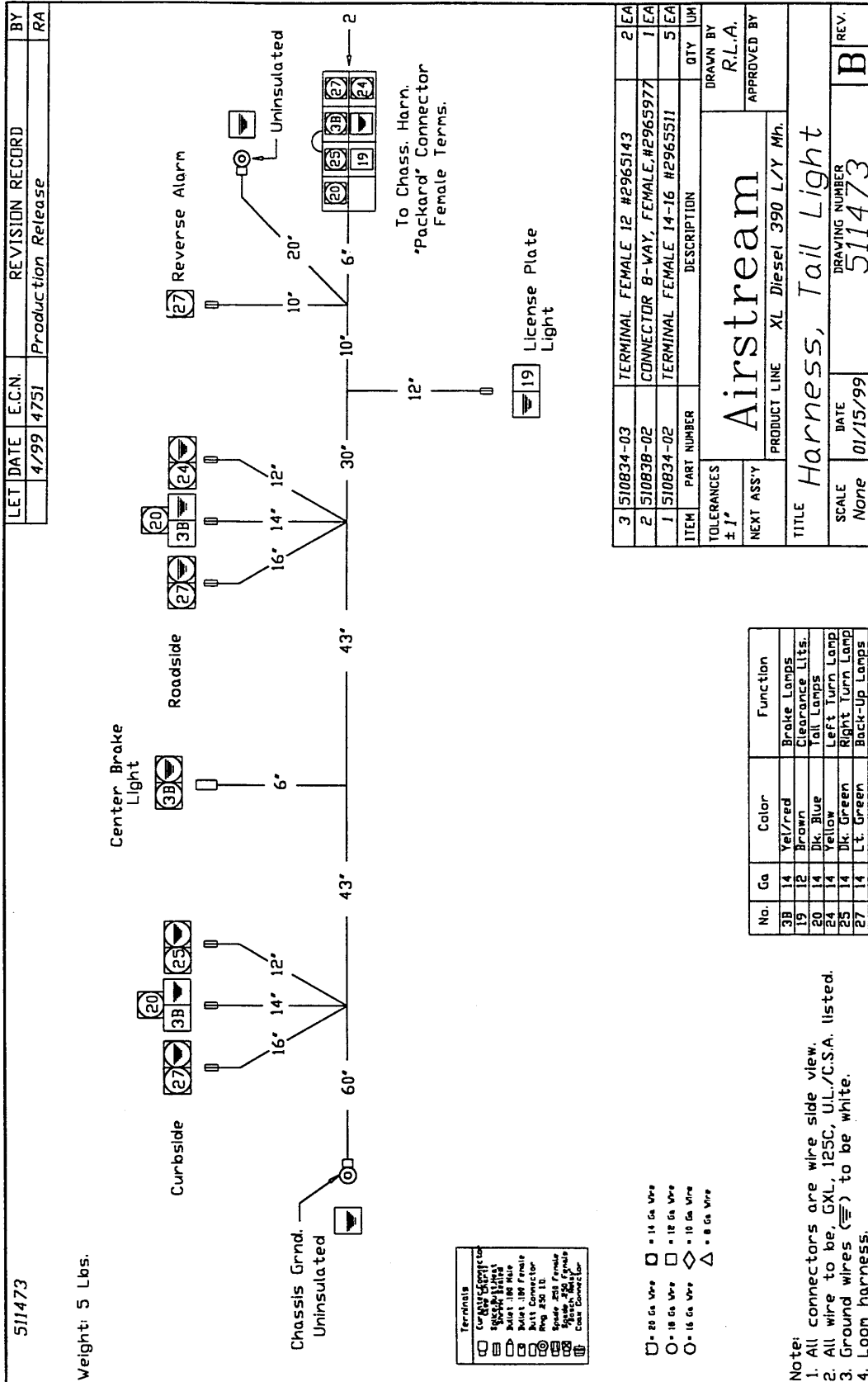

AIRSTREAM 390/395/396 XL OWNERS MANUAL
2002

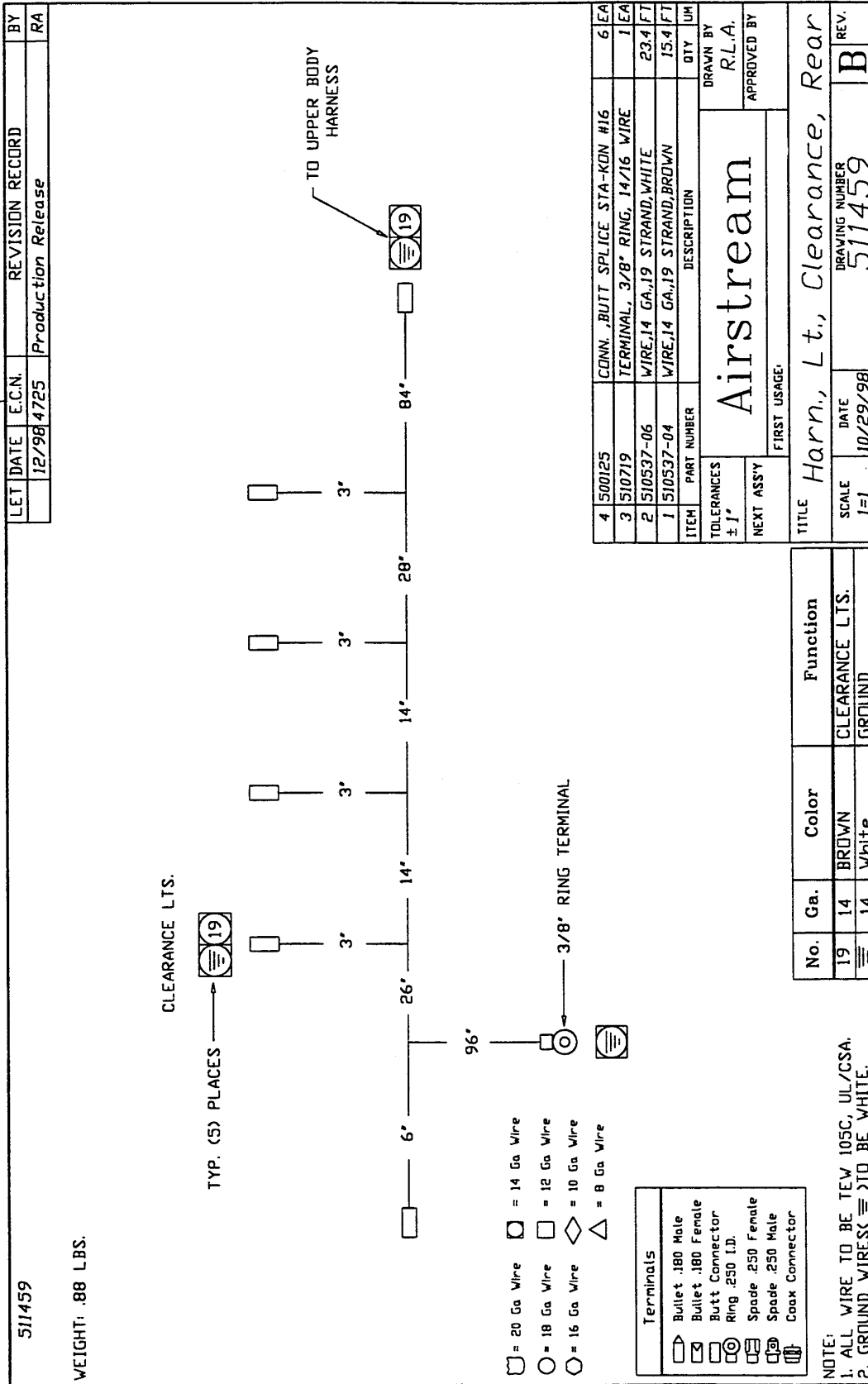

AIRSTREAM 390/395/396 XL OWNERS MANUAL

2002

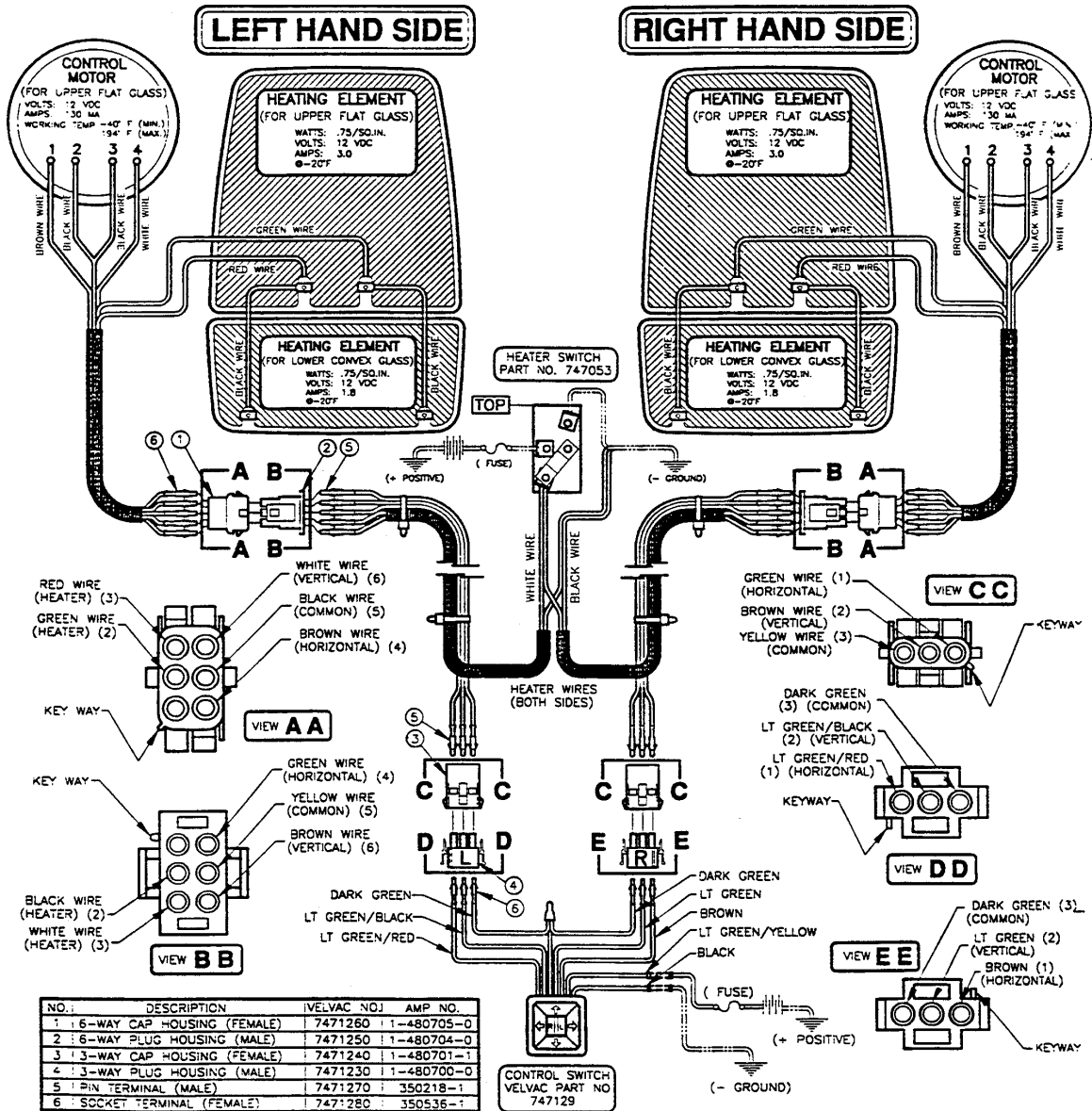

AIRSTREAM 390/395/396 XL OWNERS MANUAL
2002

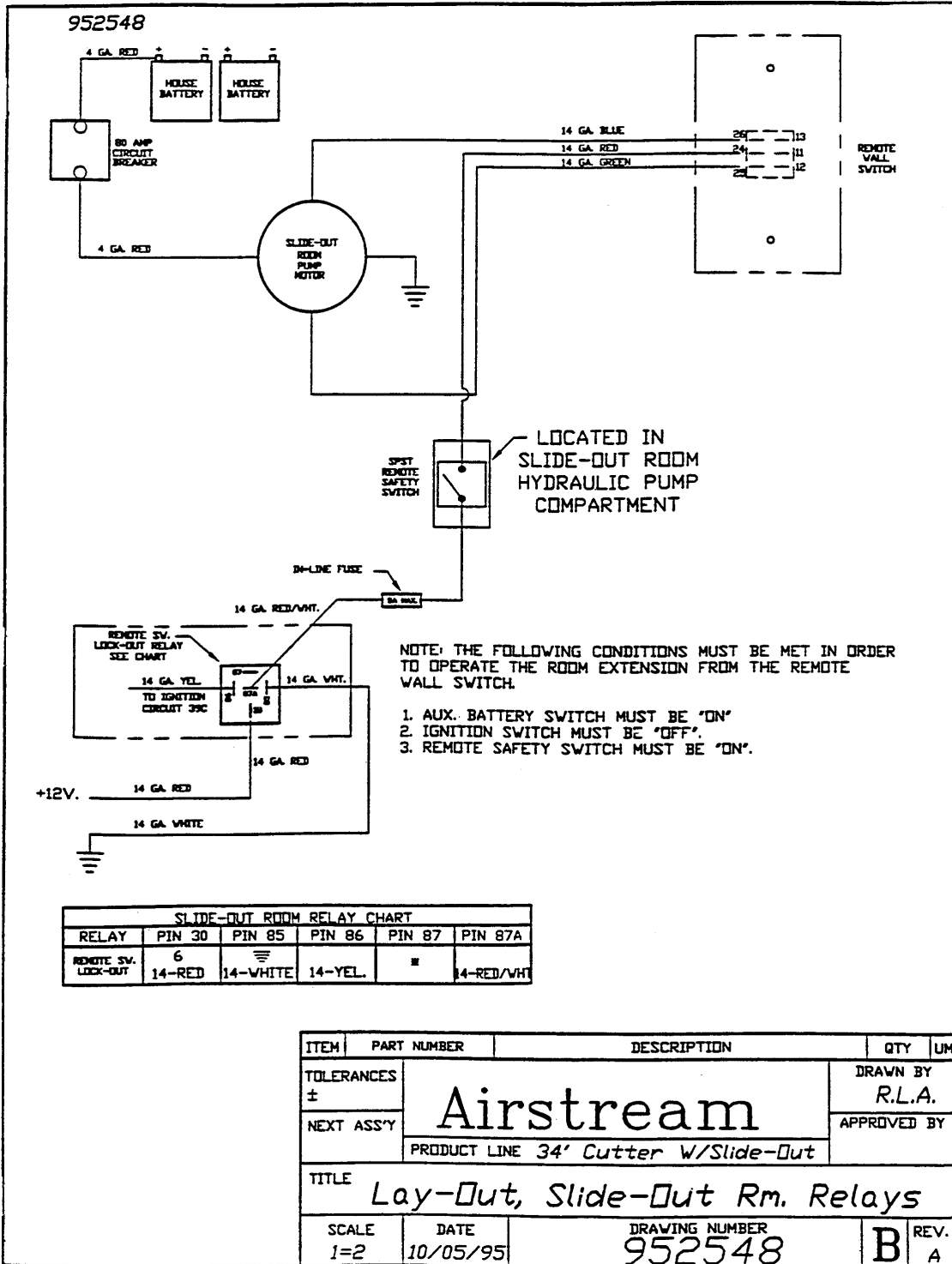

AIRSTREAM 390/395/396 XL OWNERS MANUAL

2002

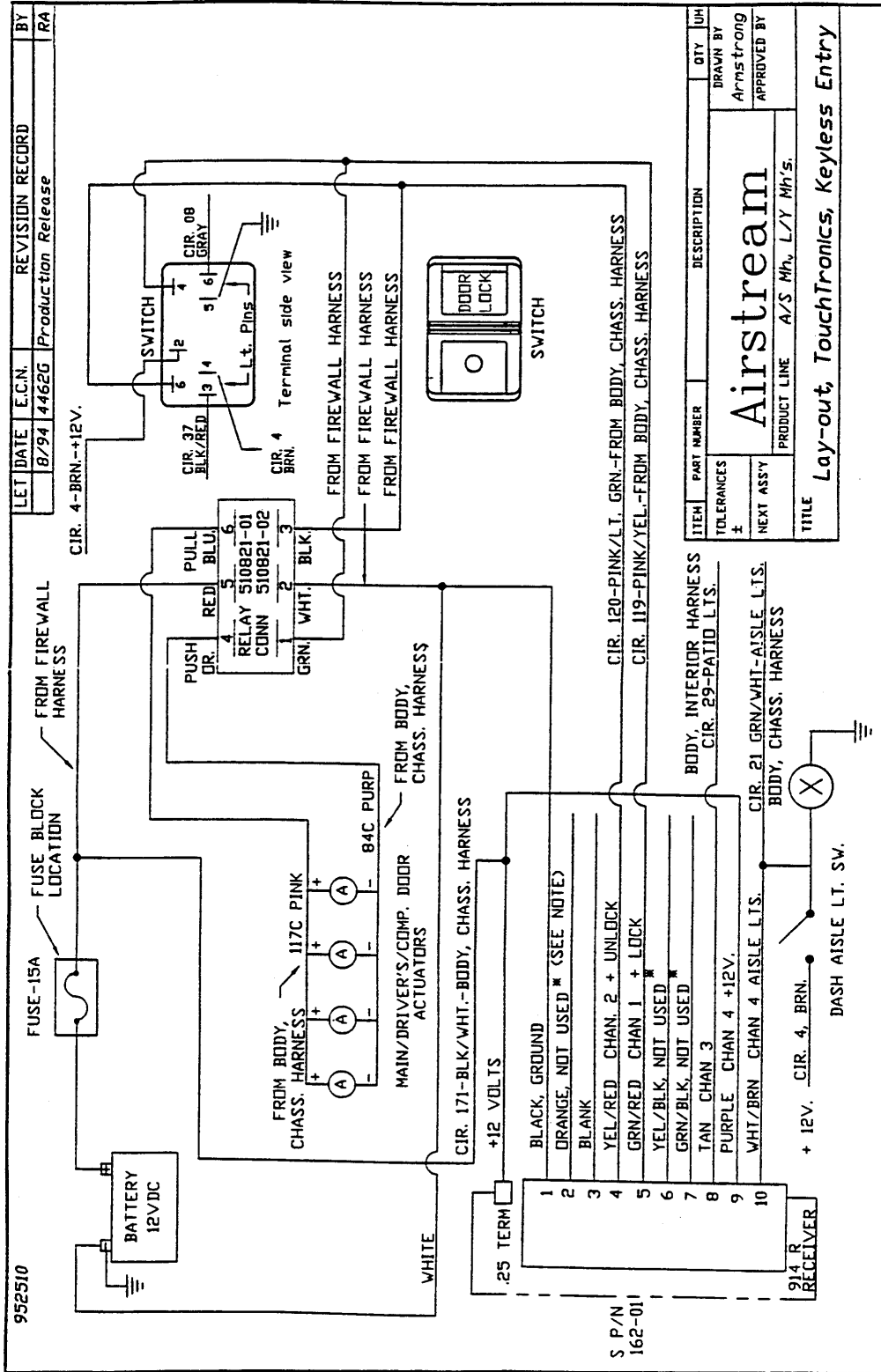

AIRSTREAM 390/395/396 XL OWNERS MANUAL
2002

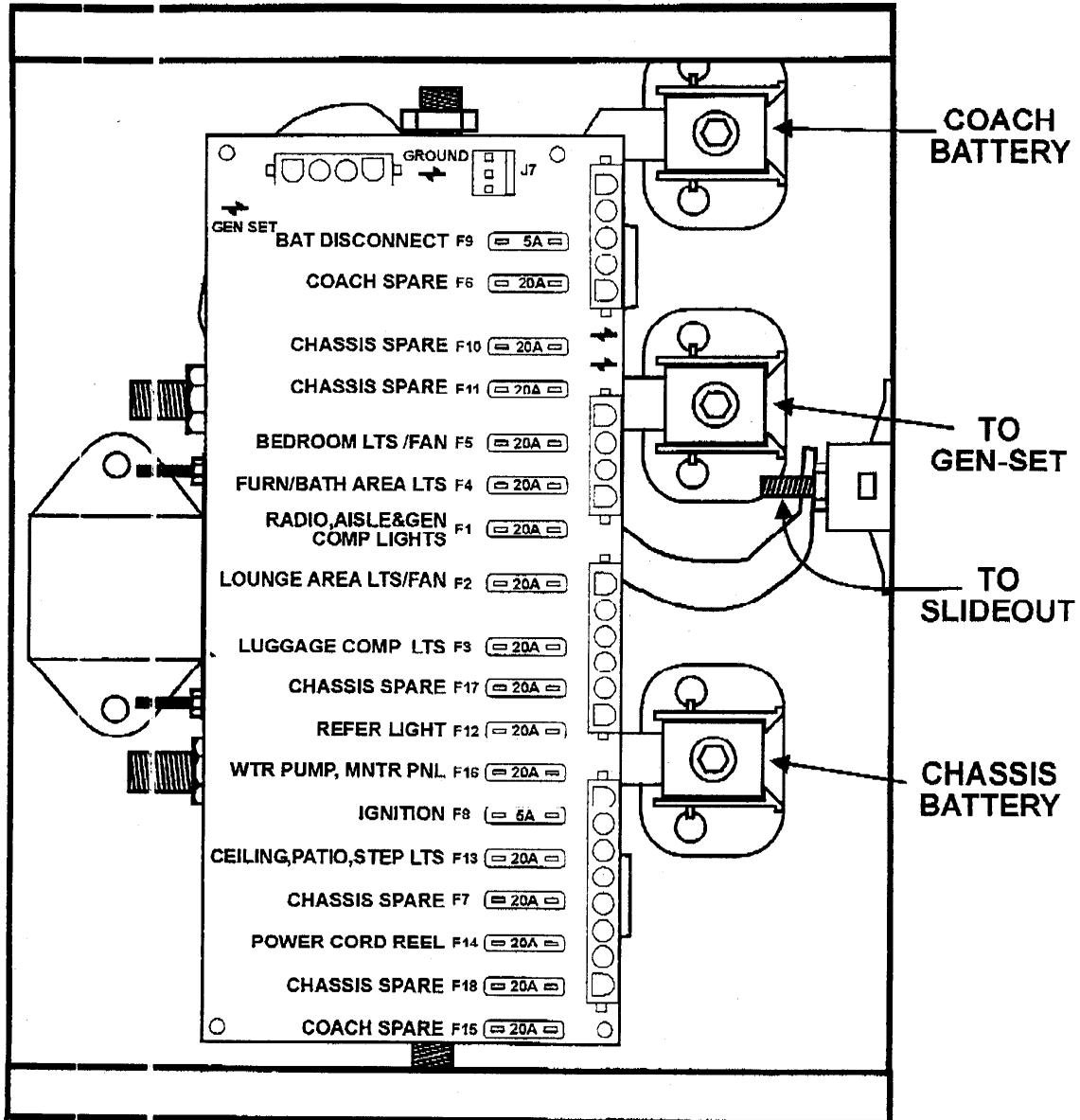

Located in roadside power cord compartment

AIRSTREAM 390/395/396 XL OWNERS MANUAL

2002

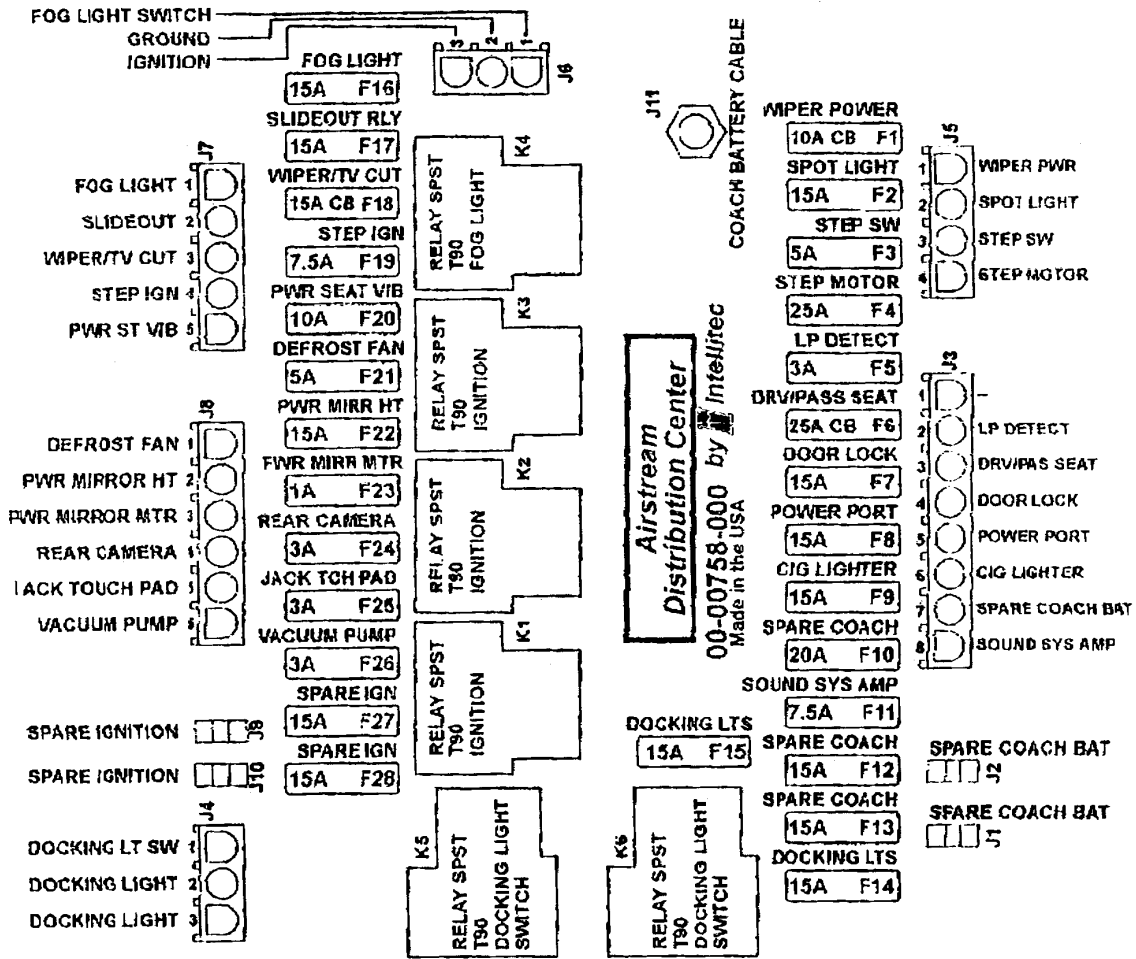

Located in Roadside front compartment.

AIRSTREAM 390/395/396 XL OWNERS MANUAL

2002

MONITOR PANEL

Ventline
P.O. Box 629
Bristol, Indiana 46507
Phone: 219-848-4491

Operation

To check tank capacities or battery condition, depress the corresponding button on the panel. In order to obtain a true reading on the batteries, you must be unplugged from city power and disconnected from your tow vehicle. Black is sewer and Gray is lavatory sink and kitchen water.

The range exhaust fan has an exterior door that must be unlatched to be effective. You'll see the two small twist latches if you look at the fan from outside the motorhome. In most circumstances you can leave the door unlatched. During storage or adverse weather conditions, latching the door is recommended.

Trouble Shooting Guide

Be sure the wiring to the panel is correct and that the house battery is well charged. All electrical connections must be correct.

NOTE: RV's are subjected to a lot of vibration from traveling on the highways, so always look for broken wires and loose or broken connections.

NOTE: If a RV has exposed holding tanks under the vehicle and the vehicle is operated in the rain, sleet or snow, the panel may show incorrect tank levels due to electrical conductivity on the outside of the tanks. Washing the tanks and sealing the connections on the outside of the well nuts with silicon sealer should correct this condition.

When troubleshooting a problem with a Ventline monitor system, always remember that there are four basic system components to consider.

- 1) The monitor panel assembly, which includes the circuit board, lights, and switching.
- 2) The wiring harness, which includes the wires and connectors that connect the monitor panel to 12-volt DC power, ground, tank resistor harnesses, LP sensors and switching.
- 3) The tank resistor harness, which includes the wires, connectors, and encapsulated electronic components.
- 4) The holding tank sensors and fresh water probes.

In many cases a malfunction of one of the above components will be reflected in another, which can result in misdiagnosis of the actual problem. Ventline recommends a consistent, methodical approach to troubleshooting in order to diagnose and correct the problem with the minimum investment in time and resources.

COMMON FIELD PROBLEMS

- Inaccurate Holding Tank Level Readings
- Some Or All Holding Tank Level Lights Not Coming On
- Some Or All Holding Tank Level Lights Continuously On - LP Gas Levels Not Reading Properly

INACCURATE HOLDING TANK LEVEL READINGS

The accuracy of two wire holding tank monitoring systems can be adversely affected by dirty tanks, unusual mineral content in the water, or improper holding tank probe location. These conditions can cause the monitoring system to have oversensitive (reads higher than actual level) or under sensitive (reads lower than actual level) readings.

AIRSTREAM 390/395/396 XL OWNERS MANUAL

2002

Oversensitive readings: Oversensitive readings can occur as a result of scum buildup on the tank walls, abnormally high mineral content in the water, or incorrectly located holding tank probes. In these situations, the monitoring system indicates higher levels than are actually present in the holding tank. Certain cleaning products and food by-products can build up on the inside walls of the holding tanks producing a layer of scum that can cause the monitoring system to read higher than the actual level. To correct this problem, the holding tanks should be cleaned periodically (consult dealer or tank manufacturer for cleaning instructions). If the problem persists after cleaning the holding tank, the ground probe can be moved farther away from the other tank probes. The increased distance between the ground probe and the other probes will decrease the sensitivity of the monitoring system.

Under sensitive readings: Under sensitive readings can occur if the mineral content of the water is abnormally low or if the holding tank probes are located incorrectly. In this case, the monitoring system indicates lower levels than are actually present in the holding tank. This problem can be corrected by moving the ground probe closer to the other probes. Moving the ground probe closer increases the sensitivity of the monitoring system.

The Ventline Adjustaboard™: In response to requests from the field for a means to adjust monitor sensitivity without relocating holding tank probes, Ventline has developed the Ventline Adjustaboard™ (patent pending). This adjustable circuit board allows for field adjustments to monitor sensitivity. As tank conditions or water mineral content changes, the monitor circuitry may be made more or less sensitive as required. Please see Appendix A for adjustment instructions.

SOME OR ALL HOLDING TANK LEVEL LIGHTS NOT COMING ON

Possible Cause

Corrective Action

No power

Verify 12 volt DC power is available from the battery or from the filtered side of the power converter. Verify 12 volt DC power is present at the circuit board.

Verify ground at panel and ground probe with a continuity tester.

Poor ground at monitor panel or at holding tank ground probe.

Wire to tank resistor harness disconnected or damaged.

Verify wire is connected and free of damage. Replace if necessary. With the tank resistor harness correctly installed and free from damage, a jumper wire containing a 47Kohm resistor placed between the holding tank ground probe and any tank level probe should cause the respective tank level lights to illuminate,

Short circuit on circuit board

If the above test fails to illuminate the level lights, repeat the test at the monitor panel. Refer to the wiring diagram for the correct wires to jump together. If lights illuminate, replace the wiring between the panel and the tank resistor harness. If lights do not illuminate, replace the circuit board.

AIRSTREAM 390/395/396 XL OWNERS MANUAL 2002

SOME OR ALL HOLDING TANK LEVEL LIGHTS ON CONTINUOUSLY

Possible Cause	Corrective Action
Foreign substances on interior of holding tank causing false readings	See inaccurate holding tank readings above. Clean holding tanks per manufacturers recommendations.
Tank sensor wire from panel to tank resistor harness shorted to ground.	Disconnect wire from panel and tank resistor harness. Verify wire is not shorted to ground with a continuity tester. Replace wire if shorted.
Tank resistor harness shorted internally	Disconnect the tank resistor harness from the tank sensors and from the wire connected to the monitor panel. Check resistance between tank sensor wires with an Ohmmeter. Typical resistance will be 68k ohm between Full and 2/3 levels, 68k ohm between 2/3 and 1/3 levels, and 136 k ohm between Full and 1/3 levels. Specific resistance will vary based on resistor harness model, but at no time should you detect a dead short or an open circuit. For resistor values specific to your application, please determine the model number of the resistor harness in question and contact Ventline for assistance. If a short or an open is detected, replace the tank resistor harness.
Short circuit on circuit board	If the above steps fail to pinpoint the specific problem, replace circuit board and re-test.

LP GAS LEVELS NOT READING ACCURATELY

Possible Cause	Corrective Action
Open circuit between panel and LP sensor causes tank to incorrectly read full. Short circuit between panel and LP sensor causes tank to incorrectly read empty.	Consult the RV manufacturer for information on troubleshooting the LP sensor. Replace the LP sensor and re-test. If the above steps fail to pinpoint the specific problem, replace circuit board and re-test.
Defective LP sensor provides incorrect signal to monitor panel causing incorrect readings.	
Short circuit in circuit board.	
Disconnect the wire running from the monitor panel to the LP sensor. Check the wire for damage and with continuity tester to verify the wire is OK. If OK, reconnect and check operation, if circuit is open or shorted replace the wire and re-test.	

AIRSTREAM 390/395/396 XL OWNERS MANUAL

2002

ADJUSTMENT INSTRUCTIONS FOR VENTLINE ADJUST-A-BOARDS™

Ventline's latest printed circuit boards (PCB's) are equipped with potentiometers (pots) that allow the holding tank sensitivity to be adjusted. This adjustment is sometimes necessary to compensate for the difference in conductivity between liquids in the holding tanks. The intent of this feature is to compensate for minor fluctuations in the mineral content of the water, not to be used in place of regular maintenance of the holding tanks. The pots should not be adjusted to compensate for dirty holding tanks. A buildup of grease, soap by-products, etc. will cause a path of least resistance in the holding tank and cause the system to be oversensitive. The holding tanks should be cleaned regularly as recommended by the tank manufacturer. See section G of this manual.

The PCB's have one pot installed for each holding tank; they are located towards the top of the PCB. Each pot is identified on the back of the PCB with P1, P2, or P3 (i.e., P1 = corresponds to the pot for holding tank 1). The monitor panel pots are initially set with the wiper blade fully clockwise. If a holding tank reading is oversensitive (the LED's are reading higher than the actual tank water level), the pot should be adjusted counterclockwise until the LED's read the correct level. Care should be taken not to force the pot past its wiper blade limits. It is not necessary to remove the PCB from the monitor panel chassis to make these adjustments.

If you have any further questions regarding this subject, please contact Ventline Engineering at (219) 848-4491.

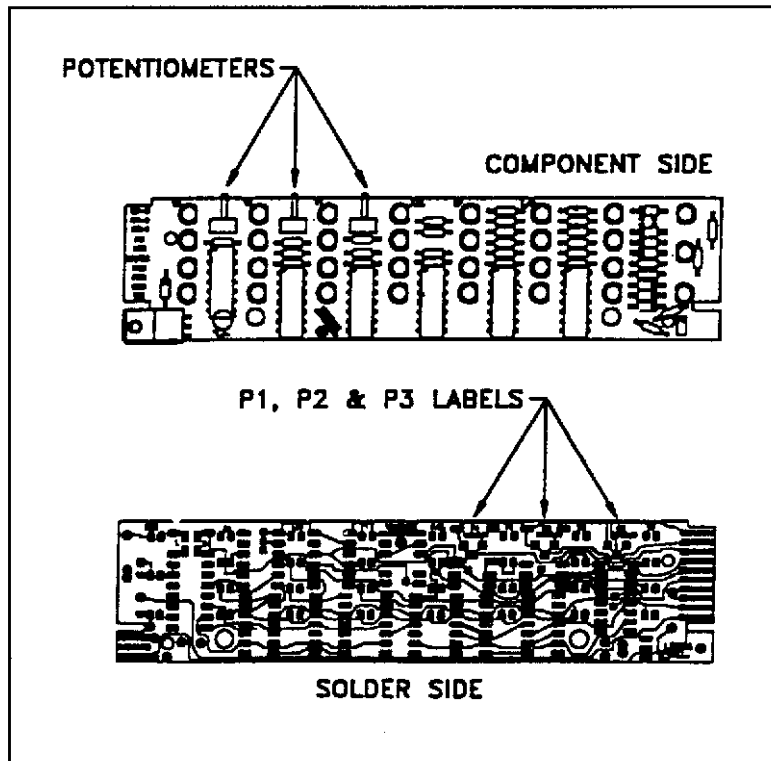

AIRSTREAM 390/395/396 XL OWNERS MANUAL

2002

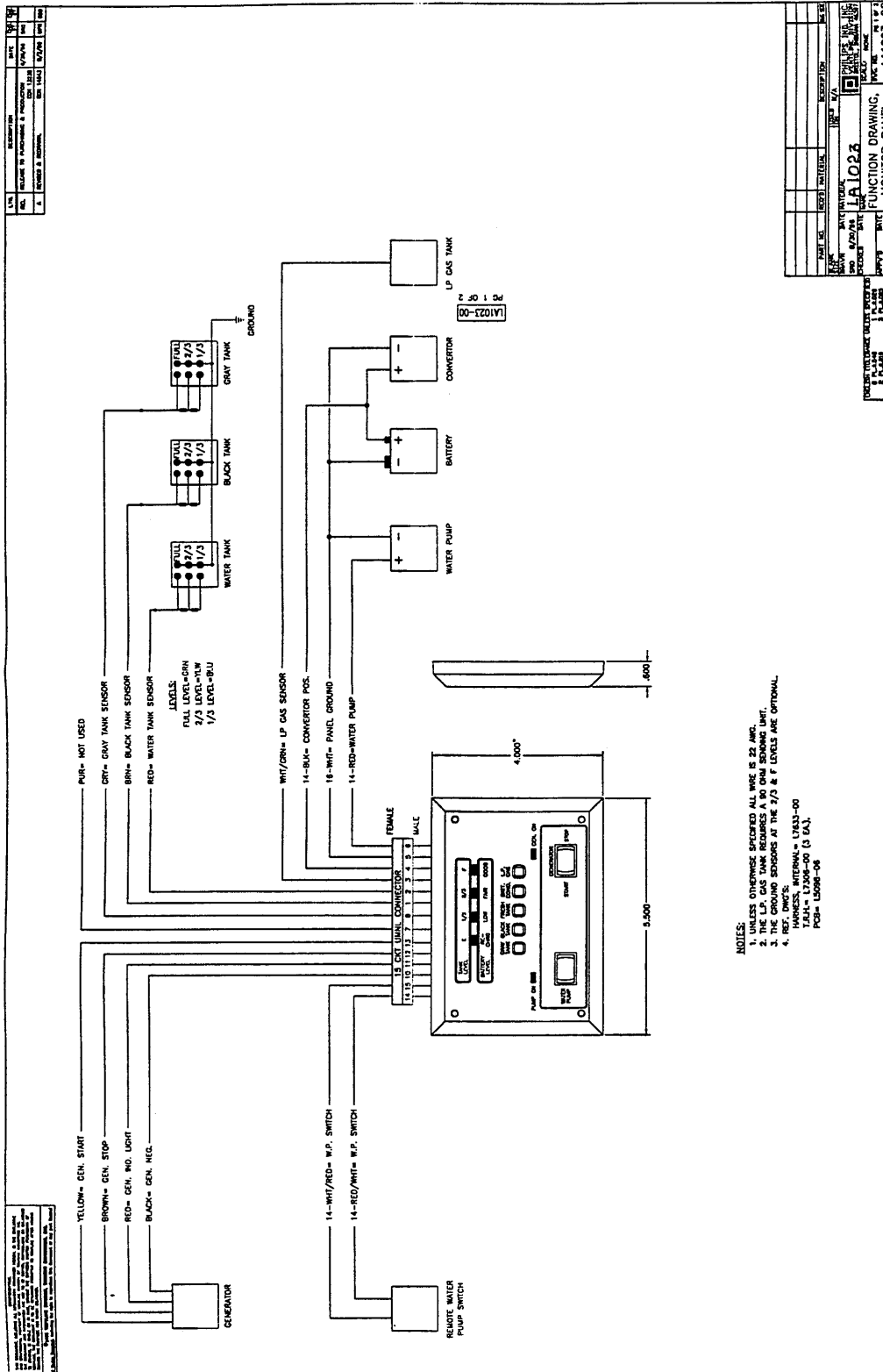

REV.	DESCRIPTION	DATE	BY
1	ISSUE TO PRODUCTION & PRODUCTION	11/19/01	WJ
2	REVISED & REWORKED	02/20/02	WJ

DATE	BY	DATE	BY
11/19/01	WJ	02/20/02	WJ
CHECKED	DATE	BY	
WJ	02/20/02	WJ	
APPROVED	DATE	BY	
WJ	02/20/02	WJ	

FUNCTION DRAWING, MONITOR PANEL
 LA1023-00

AIRSTREAM 390/395/396 XL OWNERS MANUAL

2002

TV ANTENNA

Manufacturer:

Winegard Company
3000 Kirkwood Street
Burlington, Iowa 52601
Phone: 800-843-4741

Raising Antenna to Operating Position

Turn elevating crank in "UP" direction until some resistance to turning is noted. Antenna is now in operating position. Check to make sure switch on front TV jack is on.

Rotating Antenna

Make sure antenna is in "UP" position. Pull down on directional handle with both hands until it disengages ceiling plate and rotate for best picture and sound on television set.

Lowering Antenna to Travel Position

Rotate antenna until pointer on directional handle aligns with pointer on ceiling plate.

 **WARNING:** Antenna must be in "down" position while traveling to prevent damage.

Turn elevating crank in the "Down" direction until resistance is noted. Antenna is now locked in travel position.

Checking Operation

1. Tune TV receiver to nearest station and rotate antenna for best picture and sound.
2. Turn off switch on power supply. Picture on TV receiver should be considerably degraded with the power off.

DO'S

1. Do check parking location for obstructions before raising antenna.
2. Do carefully raise, lower and rotate - if difficult, check for cause.
3. Do rotate slowly when selecting station and check fine-tuning on TV set to make sure it is properly adjusted.
4. Do lower antenna before moving vehicle.

DON'TS

1. Don't force elevating crank up or down. Check for cause of trouble.
2. Don't rotate directional handle hard against stops.
3. Don't travel with lift in up position.
4. Don't leave lift part way up or down.
5. Don't apply sealing compound or paint over top of base plate or anywhere on lift.

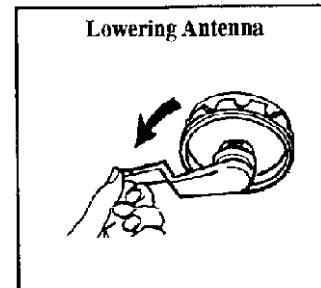
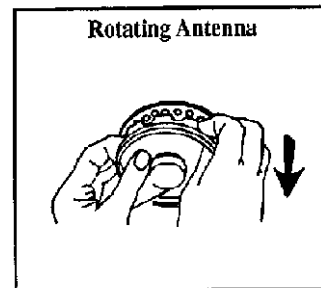
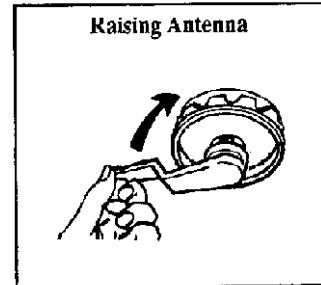

AIRSTREAM 390/395/396 XL OWNERS MANUAL

2002

Maintenance

Lubrication

To lubricate the elevating gear apply a liberal amount of silicone spray lubricant to the elevating gear with the lift in the down position, then run the lift up and down a few times to distribute lubricant over gears.

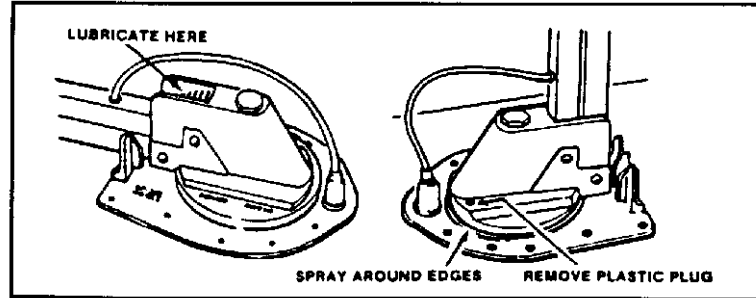

Lubricating Rotating Gear Housing

In the event that rotating the antenna becomes difficult, lubricating the bearing surface between the rotating gear housing and the base plate can restore normal operation. Any spray type silicone lubricant may be used.

Elevate antenna and remove setscrew from rotating gear housing as shown. Spray lubricant into hole and around edges of gear housing. Rotate gear housing until lubricant coats bearing surfaces and antenna rotates freely.

Elevating Shaft Worm Gear Assembly Replacement Procedure

NOTE: It is not necessary to remove the rotating gear housing (11) from the base plate (14) or remove the antenna from the roof to replace the shaft and gear assembly.

STEP 1: Lower antenna to travel position. Loosen set-screw on elevating crank (23); remove crank, spring (20), and directional handle (19).

STEP 2: Remove top retaining ring (5) from top pin (4) holding top elevating tube in rotating gear housing and remove pin.

STEP 3: Remove plug from top of rotating gear housing elevating gear (8) and remove elevating shaft assembly (10).

STEP 4: Cut new shaft to same length as one removed.

STEP 5: Lubricate worm gear on new elevating shaft assembly with spray silicone lubricant, make sure wave washer, flat washer and quad ring are on lower bearing and insert assembly in housing.

STEP 6: Install plastic plug in top of housing, re-engage elevating gear in worm gear, replace pin and retaining ring.

STEP 7: Replace directional handle, spring and elevating crank. Make sure setscrew contacts flat on shaft before tightening.

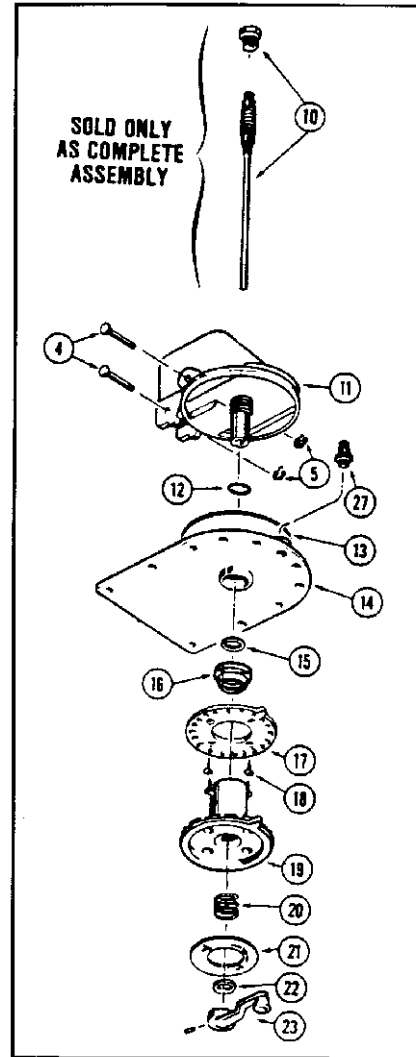

AIRSTREAM 390/395/396 XL OWNERS MANUAL

2002

PARTS DESCRIPTION

1. Antenna Head
2. LM-300 Leveling Mount
3. Boot, Coax Cable
4. Pin, Headed/Grooved
5. Ring, Retaining Snap
6. Spacer, Plastic
7. Grommet, Plastic
8. EG-87 Elevating Gear
9. Tube, Square Elevator
10. Elevating Shaft Assy
11. Housing, Rotating Gear
12. Ring Quad Seal
13. Bearing, Nylon
14. Housing, Base Plate
15. Bearing, Nylon
17. Plate, Ceiling
18. Screw
19. Handle, Directional
20. Spring, Handle
21. Decal, Crank Cover
22. Bearing, Nylon
23. Elevating Crank/Set Screw
27. Boot, Gear Housing
30. Bumper, Rubber
31. Screw

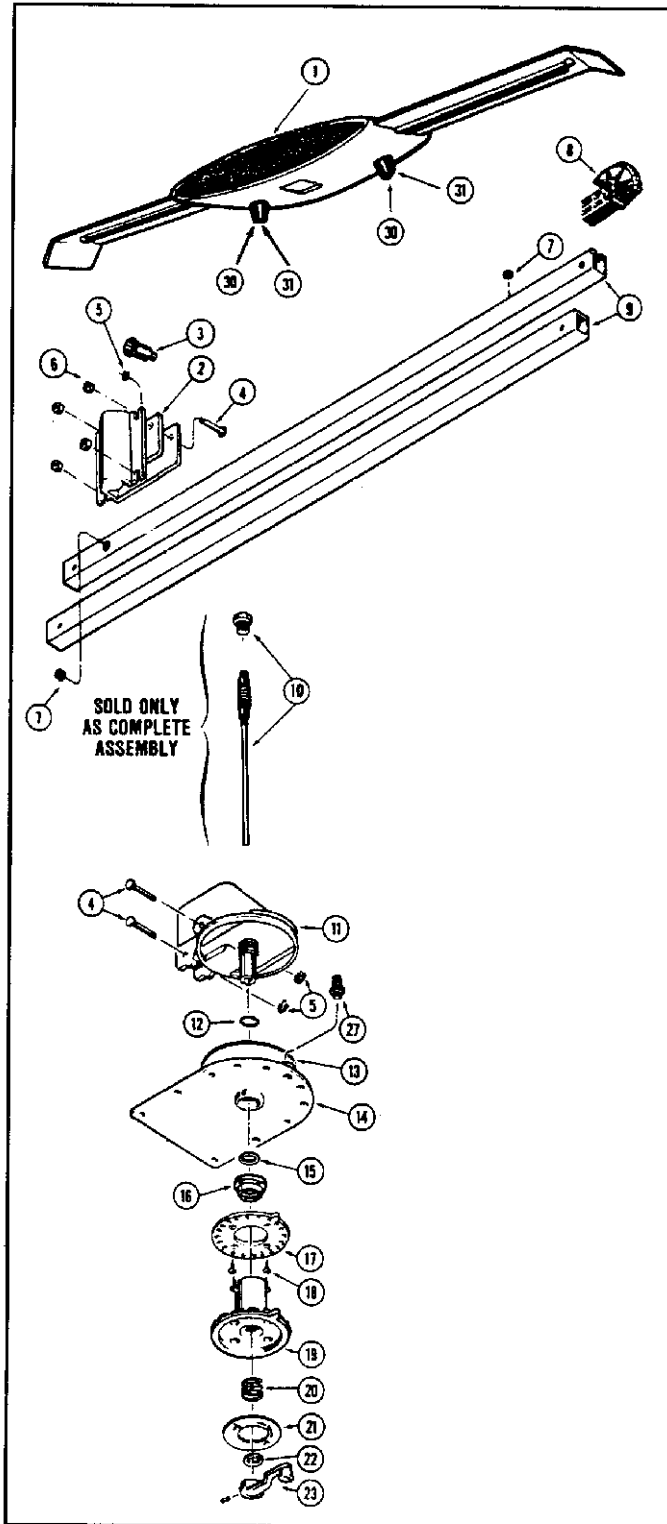

AIRSTREAM 390/395/396 XL OWNERS MANUAL

2002

SATELLITE, RADIO, AND CB ANTENNA

Not including the TV antenna, your motorhome may have as many as two other antennas.

The **AM/FM radio** antenna is a solid whip type with a flexible coil base. The coil base certainly helps extend the life of the antenna but hitting low branches and other objects at high speed can lead to severe damage.

The **CB** antenna lead-in wire is located up under the dash left of the steering column. It will be coiled along with ground and 12-volt positive wires for CB radio hook-up.

SATELLITE ANTENNA PREP

In order to facilitate the installation of either roof mount or portable satellite dish antennas Airstream has pre-wired your motorhome. On the drawing on the following page please note the two coaxial cables drawn with heavy double lines. One is labeled PREP WIRE, CEILING and the other is PREP WIRE, PORTABLE.

PREP WIRE, CEILING is used for roof mounted antenna. The end of the cable for the antenna is located in the roof, centered side to side and about four inches behind the front roof cross member. Under the outer roof sheet, in this same area, is a stiffener plate about a foot square to help support the antenna and it's attachments.

The other end of the cable is located in the roof locker next to the television and is labeled.

PREP WIRE, PORTABLE is used for the satellite dish antenna that is portable and set next to your vehicle when you pack. The end of the cable for the antenna connection is under the front hood on the curbside. You'll need to bend down and look up to see the coiled coax cable.

The other end of the cable is located in the roof locker next to the television and is labeled.

AUTOMATIC SATELLITE SYSTEM (Option)

Manufacturer:

KING DOME SATELLITE SYSTEMS
Technical Support: 1-800-982-9920
Website: www.kingcontrols.com

AIRSTREAM 390/395/396 XL OWNERS MANUAL
2002

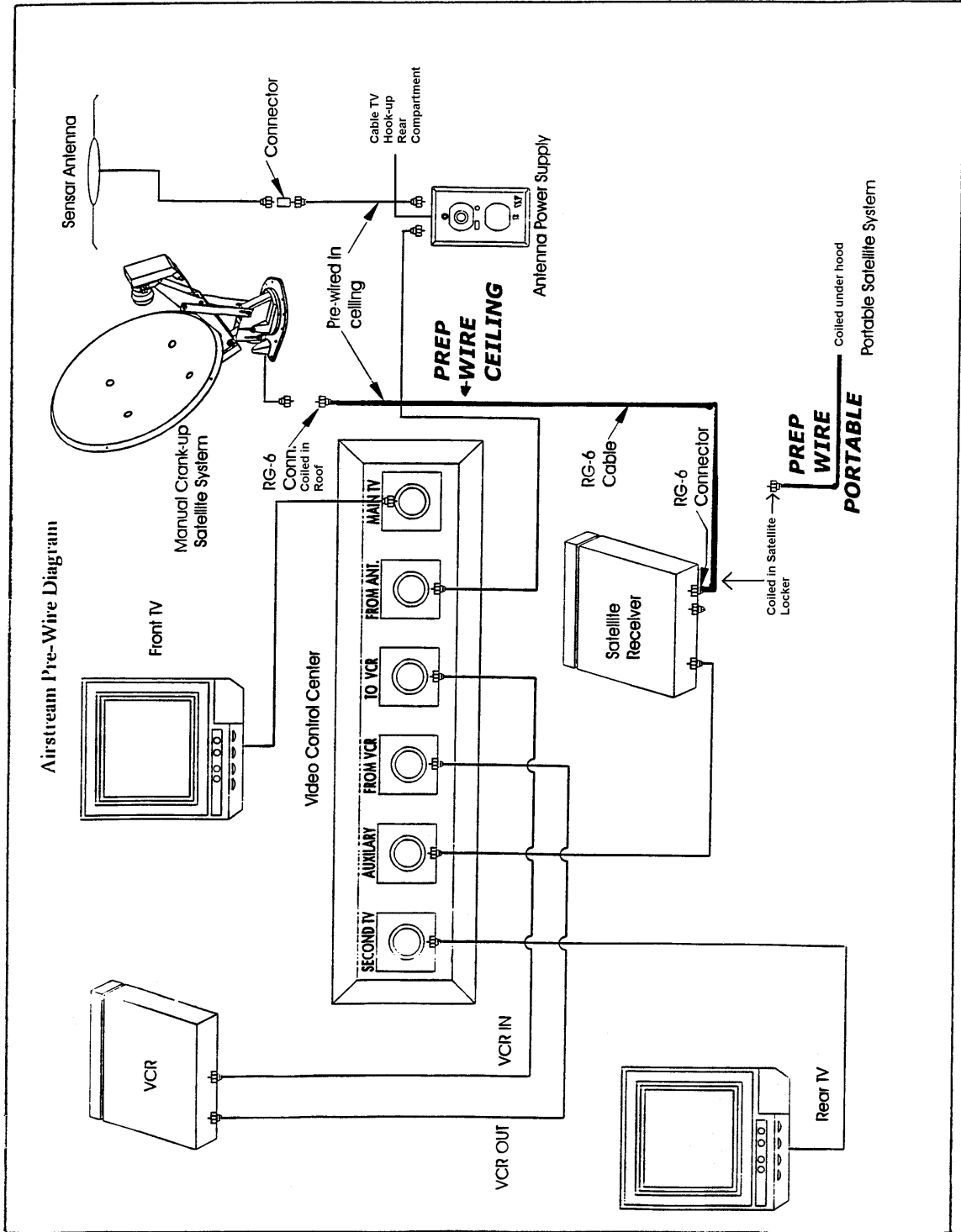

AIRSTREAM 390/395/396 XL OWNERS MANUAL

2002

110-VOLT POWER

The 110-volt system works very much like your home. The circuit breakers, located behind access door in the foot of the rear bed, supply the power to the receptacles and appliances. If a circuit is over loaded or a short circuit occurs, the breakers will "kick" out. To reactivate the circuits, turn the breaker to off, reduce the load or correct the short, and tam the breaker back to on. One of the breakers is a GFI (Ground Fault Interrupter) breaker. The intent of this breaker is to sense any loss of ground before a harmful shock could occur, and kick the breaker out. These sensitive breakers are installed in the circuit feeding the bathroom, outside receptacle, and galley area. These are the areas where the use of water or the wet ground could put a person in danger of shock. Since the GFI breaker is so sensitive, it is not unusual to have it kick out for no apparent reason.

GENERATOR

Using the generator is very much like plugging into an external power source. The generator has start switches located on the driver side armrest, monitor control panel, under the roadside bed wardrobe, and on the generator located in the front nose slide-out compartment. When you start the generator there is a built in delay of about 20-30 seconds before the circuits are switched and the generator is providing all the 110-volt power to your coach. The electrical device that has the delay and switching feature is called the generator switch over relay. The time delay feature allows the generator to reach full operating speed before it takes the "load". The switching device has two sets of points. It is normally closed so city power coming in goes through the switch and on to the main circuit breakers. When the generator is started and the delay feature is satisfied the switching device goes to the second set of points. This cuts the contact between the city power and the breaker box and makes the contact between the generator and the breaker box.

NOTE: The generator manufacturer provides an operators manual that should be reviewed prior to use.

POWER CORD

The power cord is located on an electrically powered reel in the first compartment behind the roadside rear wheels. A switch marked "in and out" controls the reel. You'll find this feature especially helpful in cool weather when the heavy power cord becomes less flexible.

If adapters are required when you plug into city Power You'll be losing some power capabilities and won't be able to operate all the appliances at the same time. The washer/dryer, air conditioners, microwave and 110-volt mode on the refrigerator are all heavy load items. The easiest way to cope with the problem is to set the refrigerator on gas then avoid operating the other appliances at the same time.



WARNING-. If adapters are required to obtain 110-volt city power it's extremely important that the polarity (ground function) is not lost. With your motorhome a circuit analyzer was provided. It is usually yellow and triangular shaped with prongs shaped to fit a standard receptacle. Plug this into any receptacle in your coach and it will indicate any polarity or grounding problem.

Loss of ground can be extremely hazardous. You might touch the motorhome and feel a slight tingle (your body has become the ground circuit) or you can receive a severe shock.

AIRSTREAM 390/395/396 XL OWNERS MANUAL

2002

INVERTER **Xantrex**
Sales and Support
North America: 800/446.6180 or 360/925.5000
Email: rv@xantrex.com

The inverter in your motorhome is located in the lower compartment furthest back on the curbside. When disconnected from 110 volt city power and the inverter is turned on 12 volt DC power from the batteries is inverted to 120 volt AC. The circuits supplied from the inverter are the microwave, front air conditioner and all receptacles on the GFI breaker. Because of the heavy load and long operating times associated with air conditioning it is not recommended the air conditioner be used with the inverter.

OPERATION OF THE INVERTER

Before attempting to operate the inverter you should review the separate Owner's Manual provided by Trace. Start the unit by depressing the Start/Stop switch. It will return to a neutral position once released.

Note: The Lamp will momentarily Hash as the unit runs through its normal diagnostic sequence.

The Lamp indicates when power is being supplied to the receptacles. If no load is sensed the inverter will not turn on.

INVERTER OPERATING TIMES

Your Airstream motorhome is equipped with a TRACE model V2512 Inverter. This inverter will supply you with quiet AC power to operate your electrical appliances. Inverters convert 12-volt direct current (DC) into 120-volt alternating current (AC).

There are three factors to consider when you select the appliances that you would like to operate with the inverter. Those considerations are: battery reserve capacity, maximum wattage and typical operating times of appliances. Good estimating of these factors will assure you have plenty of resources to operator your appliances.

BATTERY RESERVE CAPACITY

Batteries store the energy necessary for the inverter to convert DC to AC power. Your Airstream motorhome has two 4-D batteries dedicated to the inverter's use. Battery performance is affected by temperature and age. Batteries operate best when the temperature is about 77° F. If the batteries are hotter than, or colder than this temperature, performance is reduced. As batteries age, they lose some of their performance, or ability to store energy.

MAXIMUM WATTAGE

Your inverter can provide a surge of *8000 watts of power for one minute and 2500 watts continuously. This means that your use of 120-volt appliances from inverter power can total up to 2500 watts simultaneously depending on the usage time.

AIRSTREAM 390/395/396 XL OWNERS MANUAL

2002

ESTIMATING YOUR OPERATING TIMES

With your Airstream inverter installation using two 4-D batteries in good condition and fully charged you will find that the total capacity (running times) will depend on the total wattage load of the devices you are powering. In general, the running time is proportionate to the wattage.

Using the following tables, you can estimate which combinations of appliances you may operate. Table 1 indicates the typical wattage of various appliances.

Appliance	Watts	Amps	Battery Draw in Amp Hours for Run Time of:						
			5 min	15 min	30 min	1 Hr	2 Hr	4 Hr	8Hr
B&W 12" TV	40	0.3	<1	1	2	4	7	15	30
Stereo or VCR	50	0.4	<1	1	2	5	9	19	37
Light Bulb	60	0.5	<1	2	3	6	11	22	44
TV-19" Color	150	1.3	1	3	7	14	28	56	111
*Refrigerator 3 cu ft	180	1.5	<1	1	3	6	11	22	44
Computer	200	1.7	2	5	9	19	37	74	148
Blender	400	3.3	3	9	19	37			
*Refrigerator 12 cu ft	480	4.0	1	4	7	15	3	59	119
3/8" Drill	500	4.2	4	12	23	46			
Microwave	800	6.7	6	19	37	74			
Hair Dryer or Iron	1000	8.3	8	23	46	93			
Vacuum or Coffee Maker	1200	10.0	9	28	56	111			
Microwave Full Size	1500	12.5	12	35	69	139			
12 VOLT SYSTEM									

*Largest bank of incandescent light bulbs that the inverter can start simultaneously and operate for at least one minute.

Notes: If the current draw at 120 VAC is known, then the battery amperage at 12VDC will be 10 times the AC amperage divided by the efficiency (90% in this table).

Motors are normally marked with their running rather than their starting current. Starting current can be five times running current.

***Refrigerators and icemakers typically run about 1/3 of the time. Therefore, their average battery current draw is 1/3 what their amp rating would indicate.**

**AIRSTREAM 390/395/396 XL OWNERS MANUAL
2002**

TROUBLE SHOOTING GUIDE

SYMPTOMS	PROBLEM	REMEDY
No power output and no LED's	Battery voltage at the inverter's terminals is too high or low	Check the battery condition
	Battery over discharge protection circuit set too high	Lower cutout voltage an/or battery bank size setting
	Load too small for Search Mode circuit to detect	Reduce search threshold setting or defeat the Search Mode
	ComPort Accessories are improperly installed	Re-install or remove options from the ComPort
No power output and warning LED/s "ON"	High or Low Battery LED "ON"	Check the battery voltage at the inverter terminals
	Overload LED in "ON"	Remove loads from the inverter and restart
	High Temp Led in "ON"	Remove loads and let the inverter cool down before restarting
Power output is low and inverter turns loads on and off	Low battery	Check charge and condition of batteries
	Loose or corroded battery connections	Check and clean all connections
	Loose AC output connections	Check all AC output connections
Inverter clicks every 10 to 15 seconds interrupting power	Output of inverter wired back to the input (standby model only)	Check for proper AC input and Out put wiring
Charger is inoperative or intermittent	AC input voltage does not match inverter Spec	Check AC input for proper voltage and frequency of your model
	Charger controls improperly set	Refer to Owners Manual for proper setting of battery charger parameters
Low charge rate	Low <u>peak</u> AC input voltage (164 volts peak required for full charger output)	Use larger generator, speed up generator, check AC input wiring size, adjust charge rate, cable too small or too long
	AC current too small to handle load	Reduce charge amps setting and/or shed pass through loads
Low AC output voltage	Measuring with the wrong type voltmeter	Voltmeter must be a true RMS reading meter (most are not)
Low surge power	Weak batteries, battery cables too small or too long	Refer to cable and battery recommendations in owner's manual

AIRSTREAM 390/395/396 XL OWNERS MANUAL

2002

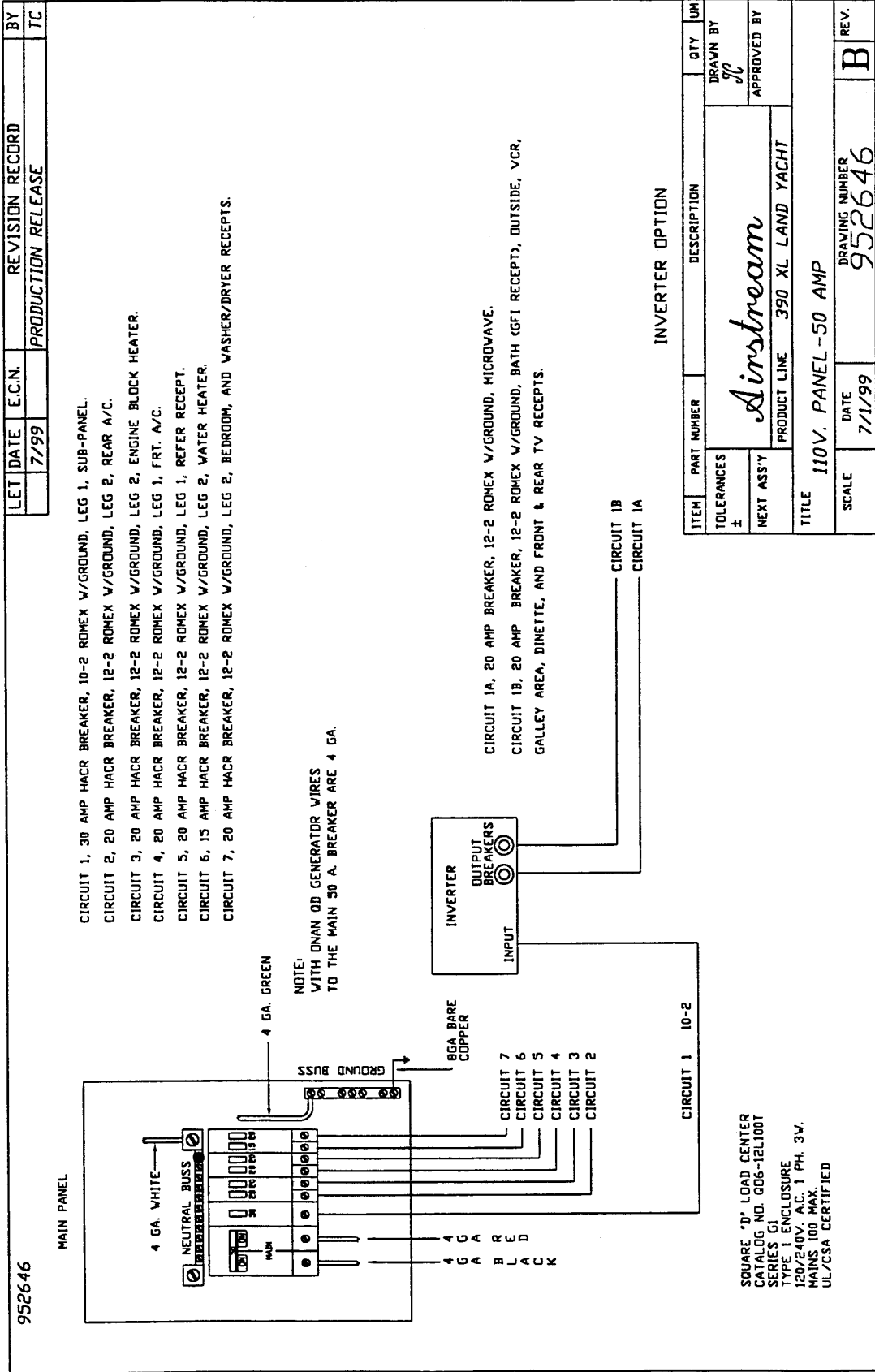

AIRSTREAM 390/395/396 XL OWNERS MANUAL

2002

Locating Shorts and Opens

The key in locating shorts and opens is isolation. The first step is to isolate the circuit with the short or open. The second step is to then isolate the section of the circuit with the fault. Once the section is identified, the specific problem can be located. The cause may be a loose or corroded connection, cut wire, worn insulation, or defective component. The following procedure is one method for isolating shorts and opens.

SHORTS

1. Isolate the circuit that has the short by noting which circuit has tripped.
2. Disconnect the power inlet cord from the power source.
3. Using the 120V schematic as a reference, disconnect outlet boxes one at a time starting at the box furthest from the distribution panel. After disconnecting each box, check for continuity between the black wire and ground or common (white) wire on the distribution panel side of the circuit. When a continuity light or ohmmeter indicates no continuity, the short is either in the receptacle just removed or the section of Romex wire between this receptacle and the previous receptacle removed.
4. Examples of a short are:
 - A) The black wire of the 120V system contacting the white wire, bare wire, or grounded surface.
 - B) An internal short in a 120V appliance.

Any damaged wire must be replaced. The National Electric Code does not permit splicing 120V wiring outside an outlet box or junction box. Also, the wire must not be exposed to an area such as a sharp metal edge that may damage the wire.

OPENS

1. Check all receptacles and components for voltage on the circuit that has the open.
2. If all receptacles and components of the circuit are without power, begin to look for the open in the distribution panel.
3. Inspect for loose or corroded connections and a faulty circuit breaker,
4. Check for power on both ends of circuit breaker. If there is no power on the inlet side of the circuit breaker, the open is between the power cord's male connector and the distribution panel.
5. Isolate the open by noting the outlets that do not have power. Example: If the bath outlet in the rear bath model has power and the converter has no power, the open is between the bath outlet and converter outlet.
6. Examples of an open are:
 - A) Loose or corroded connections.
 - B) A wire disconnected from a terminal.
 - C) Contacts in the circuit breaker that do not like contact.
 - D) A broken wire.

AIRSTREAM 390/395/396 XL OWNERS MANUAL

2002

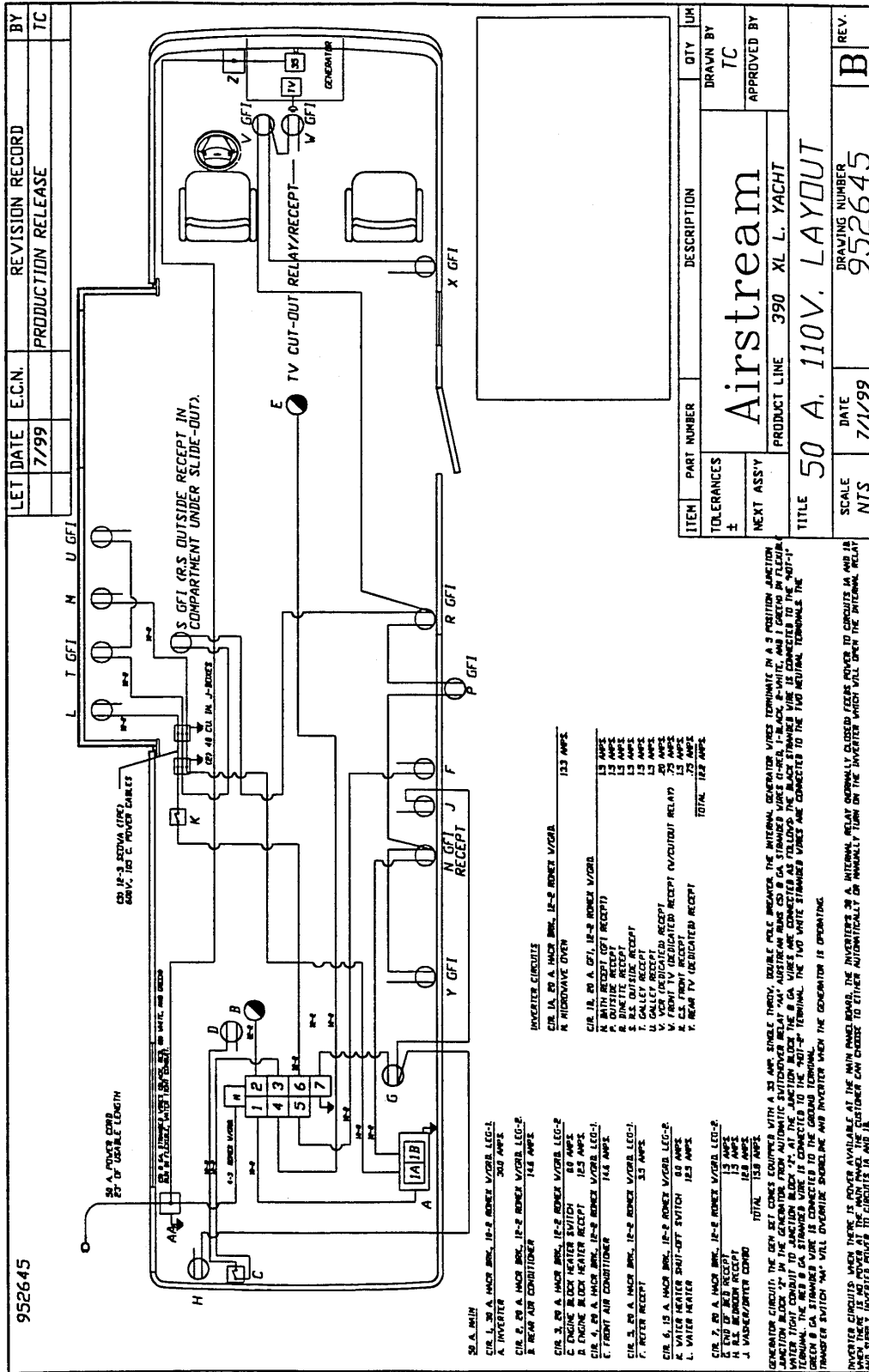

AIRSTREAM 390/395/396 XL OWNERS MANUAL

2002

SOLAR PANEL, 53 WATT (Optional)

Manufacturer: SOLAREX
630 Solarex Court
Frederick, Maryland 21703
Customer Service 1-800-521-7652



WARNING Electrical Shocks and Burn Hazards:

Photovoltaic (PV) modules generate direct current (DC) when exposed to sunlight or other light sources. Even though a single module generates low voltage and current, shocks and burns can result from contact with module output wiring. These hazards are increased when multiple modules are inter-connected to increase array output current or voltage.

PV modules do not have to be "connected" (i.e. powering a load) to generate electricity. Since modules produce electricity whenever light is present, the module front surfaces should be completely covered by an opaque cloth or other material before electrical connections to the modules or other system components are handled.

System Components

If the PV power system includes other components (batteries, charge controllers, inverters, etc.) be one to follow the safety recommendations of the manufacturers of these devices.

General Handling and Use

- The module is rugged, but it should be handled carefully. In particular, impact on the front or rear surface can damage it.
- For protection against electrical shock, use properly insulated tools and follow appropriate safety procedures. This may involve the use of additional approved safety equipment (such as insulating gloves, mats etc.)
- Do not bend the module.
- Do not disassemble the module.
- Do not attempt to increase module output by concentrating light on its surface.

Maintenance

- Inspect the module as necessary for mechanical integrity.
- Ensure that electrical connections are tight and free from corrosion.
- If the module surface is dirty, gently clean it with a soft cloth or sponge using water and mild detergent. Do not use a scrub brush; it may damage the module surface. Wear appropriate rubber gloves for protection against electric shock.

AIRSTREAM 390/395/396 XL OWNERS MANUAL 2002

Remote Control Search Light (Optional)

SEARCH LIGHT, REMOTE CONTROL

Model 60020-Series
135SL

Manufacturer:

Jabsco
1485 Dales Way, PO Box 2158
Costa Mesa, CA. 92628-2158
Tel: (714) 545-8251
Fax: (714) 957-0609

CONTROL UNIT OPERATION

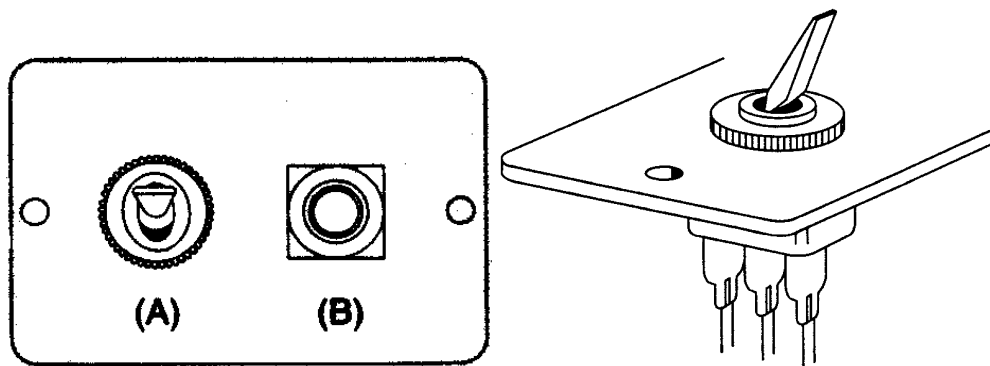

SWITCH FUNCTIONS

(A) Light Switch - On/Off switch positions.

(B) Directional Switch - Lever has eight contact positions and will operate in horizontal, vertical, and in four intermediate directions.

CLEANING OF EXTERIOR PLASTIC SURFACES

Recommendation for cleaning "Exterior Surfaces" is a solution of warm water and a mild "Dish washing" Detergent soap.

CAUTION: Do not use cleaners that contain esters, halogenated solvents, aromatic solvents, ketones and strong acids or bases.

CIRCUIT PROTECTION A 10-amp fuse is located in the On/Off toggle on control. To replace fuse grasp On/Off toggle and push in while turning to left facing control. Pull out fuse and replace. The proper fuse has been included in the fuse holder. Should this fuse blow, replace with the same size fuse after determining reason for blown fuse.

AIRSTREAM 390/395/396 XL OWNERS MANUAL

2002

SERVICE

CONTROL REPLACEMENT

Individual replacement parts are available for the control panel. To replace switches remove the two (2) screws from front of panel and pull forward, exposing wiring.

1. To remove directional switch push firmly on the front toggle and remove switch from back side of panel. Cut wires to the defective switch, and splice wires (with butt connectors) to the new switch, being sure to match wire colors. Note: Install switch with yellow wire on top for correct directional aiming.

2. To remove On/Off fuse switch disconnect wires to defective switch and pull forward with gentle rocking motion from backside of panel easing switch out. Install new switch and secure using clip retainer on backside of control panel. Reconnect wiring terminals to switch.

BULB REPLACEMENT

Remove four (4) screws and retaining bezel. Pull bulb assembly forward and disconnect spade connectors from back of bulb. Reconnect spade terminals to new bulb. Install bulb and fasten with bezel and four (4) screws.

PARTS LIST

Part No.	Description
18753-0178	Bulb Kit
43990-0000	Directional Switch
18753-0180	On/Off Fuse Switch
64073-0020	Station Selector Switch
60030-0000	Control
45969-1000	12/24 Volt Converter
60023-1000	Upper Housing
60024-1000	Lower Housing
60027-1000	Bass
60035-1000	Bulb Retainer

Note: Connect red and one black lead (16 gauges wire) from control to positive and negative leads from power source. Power leads to be 16 gauge minimum.

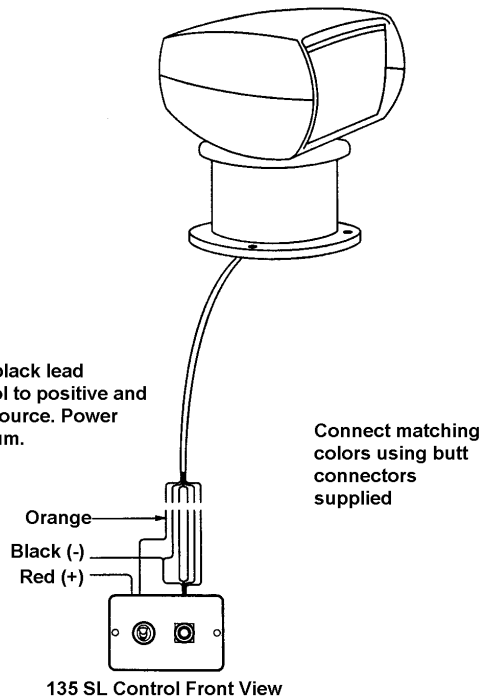

WIRING CODE	
← TO CONTROL TO CABLE →	
GRN	GRN
BRN	BRN
BLU	BLU
YEL	YEL
ORG	ORG
BLK	BLK
	GRY
NOT USED	

AIRSTREAM 390/395/396 XL OWNERS MANUAL
2002
NOTES

AIRSTREAM 390/395/396 XL OWNERS MANUAL 2002

APPLIANCES

AIR CONDITIONER

Manufacturer:

Dometic Sales Corporation
2320 Industrial Parkway
P.O. Box 490
Elkhart, IN 46515
Phone: 219-295-5228

Note: Review the air conditioning literature supplied in your Owner's Packet before proceeding.

The roof air conditioner used on Airstream motorhomes is one of the most popular on the market today. In your Owner's Packet is a set of literature covering all operating and maintenance instructions. If the literature is misplaced, please contact the air conditioner manufacturer or your Airstream dealer for replacement. A detailed service guide may be ordered from the manufacturer.

The voltage to the air conditioner is critical. We commonly refer to 110 or 120 volts, but a check with a voltmeter may find voltage much lower. Your air conditioner will probably not function if the current drops below 105 volts. Low voltage is usually associated with older or poorly maintained trailer parks, but many people have found their homes, built only twenty or thirty years ago, may not be capable of operating the air conditioner on some receptacles. Parking your motorhome so the power cord can be plugged into a receptacle close to the fuse or circuit breaker box can alleviate the problem. Avoid extension cords and adapters whenever possible. If an extension cord must be used, it should be as short and heavy as possible to provide the most current to the air conditioner.

If high temperatures are expected, you should make an effort to park in a shaded area. Starting the air conditioner early in the morning also helps. It is much easier to hold a comfortable temperature than it is to lower the temperature after the interior of the motorhome is already hot.

AIRSTREAM 390/395/396 XL OWNERS MANUAL

2002

FURNACE

Manufacturer:

Hydro Flame Corporation
1874 South Pioneer Road
Salt Lake City, UT 84104
Phone: 801-972-4621

The manufacturer of the furnace in your motorhome has been well known in the RV industry for many years. The furnace burns LP gas, and is powered by 12-volt current from the battery or power converter when plugged into city power. Operating instructions are located in your Owners Packet. If they should become misplaced new literature can be ordered direct from the manufacturer or your Airstream dealer. The manufacturer also offers a detailed service guide for your furnace.



WARNING: Carefully read all the manufacturer's instructions prior to operating. **NEVER** store flammable material next to the furnace.

If warranty service is required use only a service location recommended by the furnace manufacturer or your Airstream dealer.

The furnace is located under the refrigerator. Remove the louvered panel by pulling it off the cabinet to access it and the furnace ducts. It held on by four pressure catches. The furnace is removed from the exterior, but you must remove all heat ducts and wiring from the inside before pulling the furnace.

AIRSTREAM 390/395/396 XL OWNERS MANUAL

2002

REFRIGERATOR

Manufacturer: Dometic Sales Corporation 2320
Industrial Parkway P.O. Box 490
Elkhart, Indiana 46514
Phone: 219-295-5228

Review all Dometic Literature supplied in your Owner's Packet or stored in the refrigerator prior to operating.

In the absorption refrigerant system, ammonia is liquefied in the finned condenser coil at the top rear of the refrigerator. The liquid ammonia then flows into the evaporator (inside the freezer section) and is exposed to a circulating flow of hydrogen gas, which causes the ammonia to evaporate, creating a cold condition in the freezer.

The tubing in the evaporator section is specifically sloped to provide a continuous movement of liquid ammonia, flowing downward by gravity, through this section. If the refrigerator is operated out-of-level when the vehicle is not moving, liquid ammonia will accumulate in portions of the evaporator tubing. This will slow the circulation of hydrogen and ammonia gas, or in severe cases, completely block it, resulting in a loss of cooling.

Any time the vehicle is parked for several hours with the refrigerator operating the vehicle should be leveled to prevent this loss of cooling. The vehicle needs to be leveled only so it is **comfortable to live in** (no noticeable sloping of floor or walls).

When the vehicle is moving the leveling is not critical, as the rolling and pitching movement of the vehicle will pass to either side of level, keeping the liquid ammonia from accumulating in the evaporator tubing.

OPERATION

The refrigerator requires 12-volt current to operate even if running on LP or 110 volt modes. The 12-volt is used to power the circuit board that directs the refrigerator functions. When running in a mode such as LP, it means the heat source, by far the largest power requirement; to evaporate the ammonia is being provided by an LP Gas burner.



WARNING: Most LP gas appliances used in recreational vehicles are vented to the outside of the vehicle. When parked close to a gasoline pump, it is possible that gasoline fumes could enter this type of appliance and ignite the burner flame, CAUSING A FIRE OR AN EXPLOSION.

AIRSTREAM 390/395/396 XL OWNERS MANUAL

2002

RANGE

Manufacturer: Magic Chef
28812 Phillips Street
Elkhart, Indiana 46514
219-264-9578

People using gas ranges in their home will find little difference in the operation of the range in the motorhome. Other customers, used to electric ranges may be a little apprehensive at first; but will quickly gain confidence. The basic operation of the gas ranges have been the same for many years, but please be sure to read all the directions furnished by the manufacturer and located in the Owner's Packet. Excellent service and parts manuals are available from the manufacturer.



WARNING: The operation manual for the range is titled "Maytag RV Cooking Appliances". If this has not been provided with your trailer, contact the manufacturer listed at the top of the page to obtain. Their manual contains specialized warnings and cautions that should be reviewed prior to operating the appliance.

MICROWAVE OVENS

Only federally certified technicians are permitted to service microwave ovens. For this reason the only service instructions contained in this manual are for removal of the complete oven. If you have a microwave problem please contact the appropriate manufacturer.

Dometic Sales Corporation
2320 Industrial Parkway
P.O. Box 490
Elkhart, IN 46515
219-295-5228

Sharp Electronics Corporation
10 Sharp Plaza
Paramus, New Jersey 07652
201-5112-0055

The following steps will remove the microwave:

1. Remove the long crown-molding running along the top of the rooflocker assembly. This will expose the screws holding the panel above the microwave.
2. Remove the panel above the microwave by taking out these screws plus one on each side that are accessible by opening the cabinet doors on each side of the microwave.
3. Removing the wood panel exposes two screws holding the top of the microwave. There are also two brackets on the bottom of the microwave that are accessible by removing the two lower panels. Removing the screws and loosening the brackets will allow the microwave to be removed.

Range Exhaust

The range exhaust is incorporated into the microwave oven and the switch is located on the front. The exhaust fan has an exterior door that must be unlatched for the fan to be effective. You will see two small twist latches on the vent door on the outside of the motorhome. In most circumstance you can leave the door unlatched. During storage or adverse weather conditions, latching the door is recommended.

AIRSTREAM 390/395/396 XL OWNERS MANUAL

2002

WATER HEATER

Manufacturer: Atwood Mobile Products 4750
Hiawatha Drive P.O. Box 1205
Rockford, Illinois 61105
Phone: 815-877-7461

Note: Review the water heater literature supplied in your Owner's Packet before proceeding.

CAUTION: Hydrogen gas can be produced in a hot water system served by this heater that has not been used for a long period of time (generally two weeks or more). Hydrogen gas is extremely flammable. To reduce the risk of injury under these conditions, it is recommended that the hot water faucet be opened for several minutes at the kitchen sink before using any electrical appliance connected to the hot water system. If hydrogen is present there will probably be an unusual sound such as air escaping through the pipe as the water begins to flow. There should be no smoking or open flame near the faucet at the time it is open.

Electronic Ignition

The switch used to light your electronic ignition water heater is located in the bathroom above the lavatory top. When the switch is turned on, the red light will come on indicating the "try" mode is in effect. Normally the burner will ignite in just a few seconds, and the light will go out. If your LP system hasn't been used for some time, the system may go into safety lockout (about 20 seconds) before the air is all expelled from the lines. Turning the switch off for 30 seconds, then back on, reinstates the "try" mode.

110-Volt Operation

In the bathroom you'll see a 110-volt switch for the water heater. This provides power to the heating element. DO NOT use unless you are sure the water heater is full. (Open a faucet and see if there is a full stream of water on the hot side)

The 110-volt element may be operated at the same time as the gas burner. To operate the 110-volt by itself simply turn the electronic gas igniter switch off.

The heating element is 1500 watts so if breakers start to kick out when the air conditioner cycles you may want to turn the switch off to the heating element.

SAFETY

If your water system is full and cold and the water heater is ignited the system can see pressures as high as 120 psi before the relief valve starts to open. Since the water system normally operates in the 40-psi range the water expanding does put unusual stress on the system. This normally does not cause any problems, but the stress is easily alleviated. As the water is heating just open any faucet and run as little as a cup of water. Just removing this small amount of water reduces the pressure build up significantly.

For fun, watch the sequence of events your family goes through when you park the trailer **and ignite the water heater. More than likely someone will run water and relieve the pressure without even realizing it.**

AIRSTREAM 390/395/396 XL OWNERS MANUAL

2002

HIGH VOLUME ROOF VENT (OPTIONAL)

Manufacturer: FAN-TASTIC VENT CORP.
4349 S. Dort Hwy.
Burton, MI 48529
1-313-742-0330
1-800-521-0298

The optional high-volume roof vent system is designed to quickly exhaust stale, hot air and draw in fresh air. It's great to use when the outside temperature really doesn't call for air conditioning, but heat has built up in your coach.

OPERATING INSTRUCTIONS:

1. Rotate 3-speed switch to desired position, 0-off, 1, 2, and 3. The 3-speed switch must be set at 1, 2 or 3 to activate appliance.
2. Rotate thermostat knob toward 40° (cooler) until dome begins operating.
3. When equipped with reverse switch, there is a neutral (off) position. Fan motor will not operate when in/out switch is in its center "off" position. The dome will, however, operate up and down automatically as long as the 3-speed switch remains on.
4. To determine desired temperature setting:
 - a. Use the wall thermometer on furnace thermostat, or any interior temperature indicator.
 - b. Operate fan until interior comfort level is achieved. Rotate thermostat knob toward 110' symbol on label until dome begins closing. You now have the location for normal setting.

The thermostat sensor is calibrated approximately 4°. This minimizes rapid recycling of the unit, once desired temperature level is achieved.

5. The rain sensor built into your fan will prevent excessive rain from entering coach through the open dome. Maintain a setting above (to the right of) "rain override" zone and the dome will close when the sensor becomes wet.



WARNING: Do not leave coach unattended with thermostat knob set in the "rain override" zone.

6. A rain sensor override is built into this system so you can operate your fan during light to moderate rains. When sensor is wet, rotate fan thermostat knob to coolest position to override sensor. Dome will open and fan motor will start. When sensor has completely dried, rotate thermostat knob back to desired setting for automatic operation.
7. To close dome in extremely hot conditions, rotate thermostat knob right, past 110' symbol to off. Dome will come down.
8. Always allow dome to completely cycle up and down. If dome "hangs up" in partially open/close position, rotate thermostat knob to extreme right and then left position allowing complete cycles down and up. Now reset to original comfort level.
9. When vehicle is in storage, rotate thermostat knob to right (off), after dome closes, turn 3 speed switch to "O" (off).

CLEANING INSTRUCTIONS:

- 1) Turn fan motor OFF.
- 2) Remove 8 painted flathead Philips screws around perimeter of screen insert only.
- 3) Clean screen with soap & water solution and reinstall.

AIRSTREAM 390/395/396 XL OWNERS MANUAL

2002

SPECIFICATIONS

Airstream constantly strives to improve its product. All specifications are subject to change without notice.

Note: all weights and measurements were made on prototype vehicles. Your production motorhome may vary slightly.

DIMENSIONS 390/395/396

Exterior Height with Penquin A/C	11' 10"
Exterior Height with Brisk-air A/C	12' 1"
Interior Head Room	78 ½"
Interior Width	95"
Exterior Length	39'
Exterior Width	101"
Exterior Volume	154 CU. FT.

CAPACITIES

LPG Tank	182 Lbs.
Fresh Water Tank	105 Gal.
Grey Water Holding Tank	79 Gal.
Black Water Holding Tank	55 Gal.
Fuel Tank, Freightliner	150 Gal.

CHASSIS COMPONENTS (Please read loading section in this manual.)

Trailer Hitch	5,000 lb. tow - 500 lb. tongue weight
GAWR Front	12,000 lbs.
GAWR Rear	19,000 lbs.
Tire Size	275/70 R 22.5
*GCWR	36, 000 LBS.
GVWR	31, 000 LBS.

***Gross Combination Weight Rating. This is the total allowable weight of the motorhome combined with the weight of vehicle or trailer being towed.**

Michelin provides a Recreational Vehicle Tire Guide with each Freightliner chassis that is passed along to you in the Airstream Owner's Packet. Please take the time to read it as it has information on the loading, weighing, and inflation of your RV and its tires.

AIRSTREAM 390/395/396 XL OWNERS MANUAL
2002

INDEX

Adjustaboard, Monitor	H-29	Electrical System	H-1
Aisle lights.....	B-4	Electric Cord.....	D-9, H-36
Air Brake System Drainage.....	C-1	Electric Step.....	C-10
Air Conditioner.....	I-1	Engine Access	C-1, F-1
Air Supply, Exterior	C-19	Escape Window	D-1
Antenna.	H-29, H-31, H-34, H-35	Extended Stay	D-9
Appliances.....	I-1	Exterior	E-1
Automotive Fuses	H-2	Faucets	G-12
Auxiliary Start Switch	B-4	Fabrics, Cleaning.....	F-1
Auxiliary Battery Switch.....	H-1	Filter, Water.....	G-12
Batteries.....	H-1, H-36	Floor Tile.....	F-2
Battery Control Center	H-1	Front End Protective Film	E-1
Battery Disconnect Switch	H-1	Furnace	I-2
Bed, Rear	F-1	Fuses	H-2, H-24, H-25
Black Tank Flush.....	G-28	Gas Lines, LP	G-4
Body Armor.....	E-1	Gas, LP	G-1
Bottled Gas.....	G-1	Gauges	B-4
By-Pass Valves.....	G-5, G-25	GCWR	B-1, B-5, J-1
Cab Seats	B-5	Generator	B-4, D-9, H-36
Capacities	J-1	Ground Fault Interrupter.....	H-36
Camping	D-1	GVWR	B-1
Campground Set-up.....	D-9	Hitch Load	B-1, B-5, J-1
Carbon Monoxide Alarm.....	D-4	Humidity.....	D-8
Carpet	F-2	ICC Blink.....	B-4
Caution	Introduction	Interior	F-1
Chairs, Recliners	F-1	Inverter	H-2, H-37
Chassis	C-1, J-1	Keyless Door Lock	E-2
Circuit Breakers.....	H-2, H-36, H-40	Lavatory, Cleaning	F-2
City Water Hookup.....	G-11	Leveling.....	C-2, D-7, D-9
Cleaning Codes.....	F-2	Leveling Jacks	D-7
Cleaning, Exterior	E-1	Lights	B-4, H-3
Condensation	D-8	Loading	B-1
Counter Areas.....	F-3	Locks	E-2
Dash Air Conditioner	C-4	Lounge	F-1
Dash Instruments	B-4	LPG System.....	G-1
Defrost fans	B-4	LP Leak Detector.....	D-6
Dimensions.....	J-1	Maintenance Schedule	A-7
Docking Lights.....	B-4	Microwave Oven	I-4
Door Lock.....	B-4, E-2	Map Lights.....	B-4
Drain Hose.....	G-27	Monitor Panel	G-27, H-26
Drain Lines.....	G-11, G-25, G-27, G-30	Mirrors, Remote Control	B-4
Drain Valves.....	G-11, G-28		
Drawers	F-3		
Driving	B-1		
Driving Lights	B-4		

AIRSTREAM 390/395/396 XL OWNERS MANUAL

2002

Over night Stop	D-7
Opens and Shorts	H-41
Plastics, Cleaning	F-3
Plumbing	G 1
Power Cord.....	D-9, H-36
Power Seats	B-5
Range Exhaust Fan	D-9
Range/Oven	I-4
Rear Camera	B-4
Reporting Safety Defects.....	A-6
Refrigerator	I-3
Roof Vent	I-6
Roof Storage.....	E-2
Safety Defects, Reporting	A-6
Safety	B-2, B-3, C-12, D-1, G-2, I-5
Satellite System	H-34
Search Light	H-44
Seat Belts	B-3
Service	A-5
Sewer Hose.....	D-9, G-27
Shades	F-2
Shorts and Opens	H-41
Shower Stall	F-3
Sinks	F-2
Slide-out	D-10
Smoke Alarm.....	D-1
Sofa	F-1
Solar Power	H-36, H-43
Specifications	J-1
Step, Electric	C-10
Step Well Cover	C-19
Storage	G-24
Switches, armrest, dash	B-4
Tank Capacities	J-1
Tank Drain.....	D-7, G-27
Tank, Sewage	G-27
Tank, Water	G-5
Tank, LPG	G-1, G-3
Telephone Hook-up, exterior	D-9
Tires, Pressure	A-7
Tires, Support	C-2
Toilet	G-29
Towing	B-5
TV Antenna	H-31
Upholstery	F-1
Utility Compartment.....	G-11
Ventilation	D-8
Walls	F-3
Washing/Waxing	E-1
Warning	Introduction
Warranty	A-1, A-4
Warranty Transfer.....	A-3
Warranty Exclusions.....	A-4
Washer/Dryer (Optional).....	G-25
Water Filter.....	G-12, G-15, G-19
Water Heater.....	I-5
Water Hookup	G-11
Water Pump	G-6
Water System.....	G-5
Water Tank Fill.....	G-5, G-11
Water Tank Cleaning.....	G-6, G-28
Weighing Motorhome.....	B-2
Windshield Wiper.....	C-19
Winterizing	G-24
Winter Traveling.....	D-7
Wiring, 12 Volt.....	H-3
Wiring Diagrams, 12Volt	H-4
Wiring, 110 Volt.....	H-36
Wiring Diagram, 110 Volt.....	H-4

