

# ↗ DOMETIC

# POWER & CONTROL

# OPTIMUS EPS



EA1000, EA1100

**EN** **Electronic Power Steering with Electric Actuator**

Installation and User Manual — Book 54

**⚠ WARNING**

Cancer and Reproductive Harm  
[www.P65Warnings.ca.gov](http://www.P65Warnings.ca.gov)

[REVISION C] Form No. 682220 | ©2020 Dometic Corporation

Thank you for choosing Optimus™ Electronic Power Steering (EPS) with Electric Actuator. You have chosen a state of the art steering system that will provide years of effortless and trouble free steering performance.

## About this Book

---

This book contains:

- the user's manual for the Optimus EPS and Optimus 360 system with Electric Actuator for outboard powered boats.
- installation instructions for the EPS system with Electric Actuator.

This book must be delivered to the owner when installation is complete.



### NOTE

If you are installing the Optimus 360 joystick control system, you will need to refer to the joystick installation instructions provided separately.

### ©2020 Dometic

All Rights Reserved. This document, subject matter and all information herein is the sole, exclusive and confidential property of Dometic and shall not be disclosed, copied, reproduced or used in whole or in part for any purpose other than as specifically authorized in writing by Dometic.

---

All information, illustrations and specifications in this manual are based on the latest information available at the time of publishing. The illustrations used in this manual are intended as representative reference views only. Moreover, because of our continuous product improvement policy, we may modify information, illustrations and/or specifications to explain and/or exemplify a product, service or maintenance improvement. We reserve the right to make any change at any time without notice.



is a registered trademark of the American Boat & Yacht Council (<http://www.abycinc.org>)

NMEA 2000® is a registered trademark of the National Marine Electronics Association.

Optimus, Optimus 360, SeaStar, and BayStar are all trademarks of Dometic.

California  
Proposition 65 Warning

Battery posts, terminals, and related accessories contain lead and lead compounds, chemicals known to the state of California to cause cancer and reproductive harm.

Wash hands after handling.

# Table of Contents

<b>1 Important Safety Information</b>	1-1
1.1 Explanation of symbols	1-1
1.2 Safe operation	1-2
1.3 Safety considerations for installers	1-3
1.4 Safety Decal	1-4
<b>2 System Overview</b>	2-1
<b>3 Using Your EPS System</b>	3-1
3.1 Before first use	3-1
3.1.1 System inspection	3-1
3.1.2 Interference check	3-2
3.2 System operation	3-3
3.2.1 First time operation	3-3
3.3 CANtrak display	3-4
3.3.1 CANtrak display navigation	3-5
3.3.2 CANtrak display map — All Helms Active	3-6
3.3.3 All Helms Active screen	3-7
3.3.4 Steering maintenance screen	3-7
3.3.5 Settings screen	3-8
3.3.6 Speed sensitive steering	3-9
3.3.7 Display brightness	3-9
3.4 Autopilot operation	3-10
3.5 Joystick operation (if so equipped)	3-11
3.5.1 Joystick fundamentals	3-11
3.5.2 Joystick tips	3-14
3.5.3 Joystick operation examples	3-15
3.5.4 Returning to conventional operation	3-18
<b>4 System Faults and Hazards</b>	4-1
4.1 Fault types	4-1
4.2 Fault notification	4-1
4.3 Danger fault handling	4-2
4.3.1 Limp home	4-2
4.3.2 Emergency manual steering override	4-4
4.4 Warning fault handling	4-5
4.5 Loss of CANtrak display	4-5
<b>5 Installation</b>	5-1
5.1 Before you start	5-1
5.2 Electric Actuator	5-1
5.2.1 Planning	5-2
5.2.2 Installation	5-2
5.2.3 Ground strap installation	5-5
5.3 Actuator harness	5-6
5.3.1 Planning	5-6
5.3.2 Bulkhead installation	5-8
5.3.3 Harness protection	5-10
5.3.4 Harness connection to actuator	5-11

5.4	Electronic helm .....	5-11
5.4.1	Planning .....	5-12
5.4.2	Helm installation .....	5-12
5.5	CANtrak display.....	5-17
5.5.1	Planning .....	5-17
5.5.2	Installation .....	5-17
5.6	Electrical connections.....	5-18
5.6.1	Power connection .....	5-18
5.6.2	CAN1 connection .....	5-22
5.6.3	CAN2 connection .....	5-28
5.6.4	CAN3 connection .....	5-31
5.6.5	Ignition sensing .....	5-32
<b>6</b>	<b>Setup and Configuration .....</b>	<b>6-1</b>
6.1	First time power-up .....	6-1
6.2	Initial setup.....	6-2
6.2.1	Select system type .....	6-2
6.2.2	Select steering type .....	6-3
6.2.3	Select number of devices .....	6-3
6.2.4	Select device locations.....	6-3
6.2.5	Select RPM source .....	6-3
6.3	Steering setup .....	6-4
6.3.1	Configuration .....	6-4
6.3.2	Calibrating the Electric Actuators.....	6-4
6.3.3	Set Proportional Sensitivity.....	6-7
6.3.4	Check installation .....	6-7
6.3.5	Move steering .....	6-7
<b>7</b>	<b>Maintenance and Troubleshooting .....</b>	<b>7-1</b>
7.1	Maintenance schedule.....	7-1
7.1.1	Owner/Operator.....	7-1
7.1.2	Qualified marine mechanic .....	7-1
7.2	Troubleshooting guide .....	7-2
<b>Appendix A</b>	.....	<b>A-1</b>
A.1	Helm templates .....	A-1
A.1.1	Front Mount Helm (EH1510/EH1512).....	A-1
A.1.2	Sport Plus Tilt Helm (EH1530/EH1532) .....	A-3
A.1.3	Classic Tilt Helm (EH1550/EH1552) .....	A-5
A.1.4	Rear Mount Helm (EH1570/EH1572).....	A-7
A.2	CANtrak display template .....	A-9
A.3	Bulkhead fitting template .....	A-11
<b>Appendix B</b>	.....	<b>B-1</b>
B.1	Bolt torque specifications.....	B-1
B.2	System specifications .....	B-1
<b>Warranty</b>	Statement of limited warranty Return goods procedure Technical support	



# 1 Important Safety Information

Safe operation of Optimus EPS with Electric Actuator depends on proper installation and maintenance of the system, as well as the operator's safe judgment, boating knowledge, and expertise.

The installer and operator must read and understand the safety requirements in this section before installing or using the steering system. If you have any questions about safe installation or operation of this system, contact Dometic Marine. Please don't guess.

## 1.1 Explanation of symbols

---

The symbols below are used throughout this publication to alert you to potential hazards involved with the operation and installation of this product. Observe these warnings and notices carefully. The safety alerts alone cannot eliminate hazards; strict compliance with any special instructions during installation, operation, and maintenance, along with common sense operation, are important measures to prevent hazardous situations.



### **DANGER!**

**Safety instruction:** Indicates a hazardous situation that, if not avoided, will result in death or serious injury.



### **WARNING!**

**Safety instruction:** Indicates a hazardous situation that, if not avoided, could result in death or serious injury.



### **CAUTION!**

**Safety instruction:** Indicates a hazardous situation that, if not avoided, could result in minor or moderate injury.



### **NOTICE!**

Indicates a situation that, if not avoided, can result in property damage.



### **NOTE**

Supplementary information for operating the product.

## 1.2 Safe operation

---



### **WARNING!**

The safety information below is intended to inform you of hazards that may be present when operating a boat equipped with Optimus EPS. Read and understand this information.

### **General**

- Read and understand this manual, the Quick Reference Guide, and any other documentation provided with your steering system.
- Know and obey all applicable federal, state, and municipal laws and regulations that govern boating in your area. Dometic recommends all boat operators take a boating safety course.
- Never operate a boat while under the influence of drugs or alcohol.

### **Before every use**

- Perform the system inspection as described in section 3.1.1.
- Make sure your Quick Reference Guide and/or this manual is on your boat. Both contain important safety information that you may need in the event of a system fault while on the water.



### **WARNING!**

Do not operate the boat if any component is not in proper working order. It may result in a loss of steering control, which could lead to a collision and/or ejection from the boat, causing property damage, personal injury, and/or death.



### **WARNING!**

Do not operate your boat without a functioning CANtrak display.

### **During use**

- Wear a Coast Guard-approved personal flotation device (PFD).
- Attach the engine shut-off lanyard to your PFD.
- Do not allow anyone not familiar with the controls (steering, shift/throttle) to operate the boat.

### **After use**

- Rinse off the Electric Actuator(s) thoroughly, using only fresh, clean water at low pressure. Never use high-pressure water from a hose nozzle or pressure washer.
- Do not use acetone, or cleaners containing ammonia, acids, or any other corrosive ingredients, on any Optimus components.
- Some products formulated for cleaning fiberglass hulls are known to aggressively corrode stainless steel shafts. If using a hull cleaner, avoid overspray on to the Electric Actuators. Rinse off any overspray immediately with fresh, clean water.

# 1.3 Safety considerations for installers

---



**WARNING!**

Optimus EPS with Electric Actuator must be installed by an authorized dealer or OEM boat builder.

**Before installation**

- Read and understand this manual, and any other manuals supplied with this system.
- Ensure you have all the required components on hand before you start.
- Do not use a wheel-mounted trim switch with coiled cord. The cord can wrap around the steering wheel shaft and inhibit steering.

**During installation**

- Install components as instructed in this manual. Some component parts and kits may contain additional installation instructions – refer also to those instructions.
- Do not substitute any component of the system. Dometic and Optimus parts are rigorously engineered and tested to ensure system integrity. Substitution of components may compromise safety, performance, and reliability.
- If an instruction is unclear, contradictory, or you are otherwise unsure how to proceed, do not guess. Contact Dometic Marine technical support.

**After installation**

- Perform the system inspection and interference checks described in section 3.1.1 and 3.1.2.
- Correct any interference issues before handing the boat to the owner.



**WARNING!**

Failure to comply with these instructions may result in a loss of steering control, which could lead to a collision and/or ejection from the boat, causing property damage, personal injury, and/or death.

# 1.4 Safety Decal

The electric actuator is shipped with a decal that warns of safety hazards and contains some instructional information. In the event the decal has been damaged, or is otherwise illegible, the decal is reproduced here.



<h2>OPTIMUS ELECTRIC STEERING ACTUATOR</h2> <p>ABYC CE 12V ISO 25197, Ignition Protected, SAE J1171, Patent Pending. Made by Dometic, Richmond, BC, Canada</p>		Part No. <b>EA1000</b> 
<p><b>⚠ WARNING</b></p> <p>REFER TO INSTRUCTIONS FOR SPECIFIC APPLICATION. INSTALL AND MAINTAIN IN ACCORDANCE WITH DOMETIC INSTRUCTIONS. FAILURE TO COMPLY WITH ABOVE MAY RESULT IN LOSS OF STEERING CONTROL LEADING TO POSSIBLE EJECTION FROM VESSEL CAUSING PROPERTY DAMAGE, PERSONAL INJURY AND/OR DEATH.</p>	<p><b>TO MANUALLY REPOSITION STEERING</b></p> <ol style="list-style-type: none"> <li>Loosen clamp bolts on BOTH ends of shaft.</li> <li>Rotate shaft to reposition steering using tool provided (3/8" wrench).</li> <li>Tighten both clamp bolts after repositioning.</li> <li>Steering <b>MUST</b> be recalibrated after repositioning.</li> <li>Refer to manual or QR card for additional info.</li> </ol>	Serial No. <b>SEA00001</b> 
<p><b>⚠ WARNING</b></p> <p>FAILURE TO ADHERE TO THESE WARNINGS MAY RESULT IN LOSS OF STEERING CONTROL, LEADING TO POSSIBLE EJECTION FROM VESSEL CAUSING PROPERTY DAMAGE, PERSONAL INJURY AND/OR DEATH.</p>	<p><b>PRIOR TO EVERY USE:</b></p> <ol style="list-style-type: none"> <li>Verify immediate steering response when turning steering wheel(s).</li> <li>Inspect all steering components, cables and connections for wear, kinking, and/or signs of damage.</li> <li>Check for binding, loose or worn steering components.</li> </ol> <p>DO NOT operate boat if any component is not in proper working condition.</p>	<p><b>INSTALLATION, USE AND MAINTENANCE:</b></p> <ol style="list-style-type: none"> <li>Ensure actuator is compatible with tiller and U.S.C.G ratings.</li> <li>Interference with any object <b>MUST</b> be corrected prior to use.</li> <li>Maintain steering system at a minimum of twice per year.</li> <li>Refer to Installation and User's Manual for important safety information</li> <li>Ensure all electrical connections are properly secured and free from corrosion.</li> <li>Keep magnets away from steering cylinders.</li> </ol> <p><b>www.dometic.com</b> SeaStar 351008</p>

Figure 1-1. Safety Decal.

# 2 System Overview

Optimus EPS with Electric Actuator is the marine industry's first fully electric, retrofittable, steer-by-wire system for outboard engines. This premium system is engineered for simple installation, with fewer parts than our standard electro-hydraulic EPS, no hoses to route, and no hydraulic system to purge. With a list of extensive safety features including redundant communications, self-monitoring, and fault alerts, Optimus EPS with Electric Actuator will give you years of safe and reliable operation.

The system consists of the major components listed below. Figure 2-1 and figure 2-2 show these components in a schematic system diagram.

---

## Electric steering actuator and steering control unit (SCU)

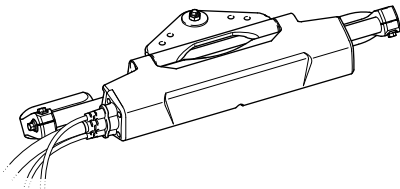

The electric steering actuator is a state-of-the-art device that converts the rotation of a brushless DC motor into precise linear motion and position control. It mounts directly to the outboard motor in place of a conventional hydraulic steering cylinder.

The Steering Control Unit (SCU), integrated with the actuator, receives wheel movement messages from the helm and controls the actuator to steer as required. The SCU manages CANbus communications between system components, synchronizes multiple actuators, and monitors rudder position. The SCU can also respond to inputs from the SeaWays autopilot, or from a certified third-party autopilot system. The SCU replaces the PCM used in the standard Optimus electro-hydraulic system.

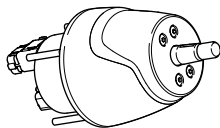

## Electronic helm

The helm converts steering wheel movement into digital messages that are sent over CAN1 to the SCU. A system of friction plates in the helm allow the steering effort to be adjusted according to a setpoint received from the SCU. (A steering wheel is not included with the Optimus EPS system.)

---

## CANtrak display

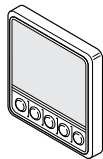

The CANtrak displays system status and fault information and enables the operator to make changes to user-adjustable steering settings (when so configured by the installer). It is also used to activate the optional SeaWays autopilot and SeaStation GPS anchoring features on boats with the Optimus 360 joystick control system. Authorized installers have access to additional menus with system setup and calibration tools.

---

## CAN Networks

CAN (controller area network) is a serial network protocol that is widely used in marine and automotive control systems. Each device (node) on the network can send and receive data using specially formatted messages. The ability to reliably communicate data between devices is what enables the steer-by-wire functionality of Optimus EPS.

Optimus EPS uses up to three independent CAN networks, designated CAN1, CAN2, and CAN3.

- CAN1 is a low-speed, fault-tolerant network with redundant power wiring. It is used for safety-critical communication between the helm and SCU.

- CAN2 is a high-speed network used to communicate with a third-party autopilot, and with a joystick and shift/throttle controls on an Optimus 360 joystick control system. Use of this network is optional on single-engine systems.
- CAN3 is a public network using the NMEA 2000 protocol. The Optimus system broadcasts public messages onto this network and monitors the network for engine RPM.

---

### **Joystick (optional)**



The optional Optimus 360 joystick control system converts an operator's inputs into steering, shift, and throttle commands using this three-axis joystick controller. The joystick can rotate, move forward and back, and side to side. Combinations of these movements give the operator precise control of the boat's direction and speed.

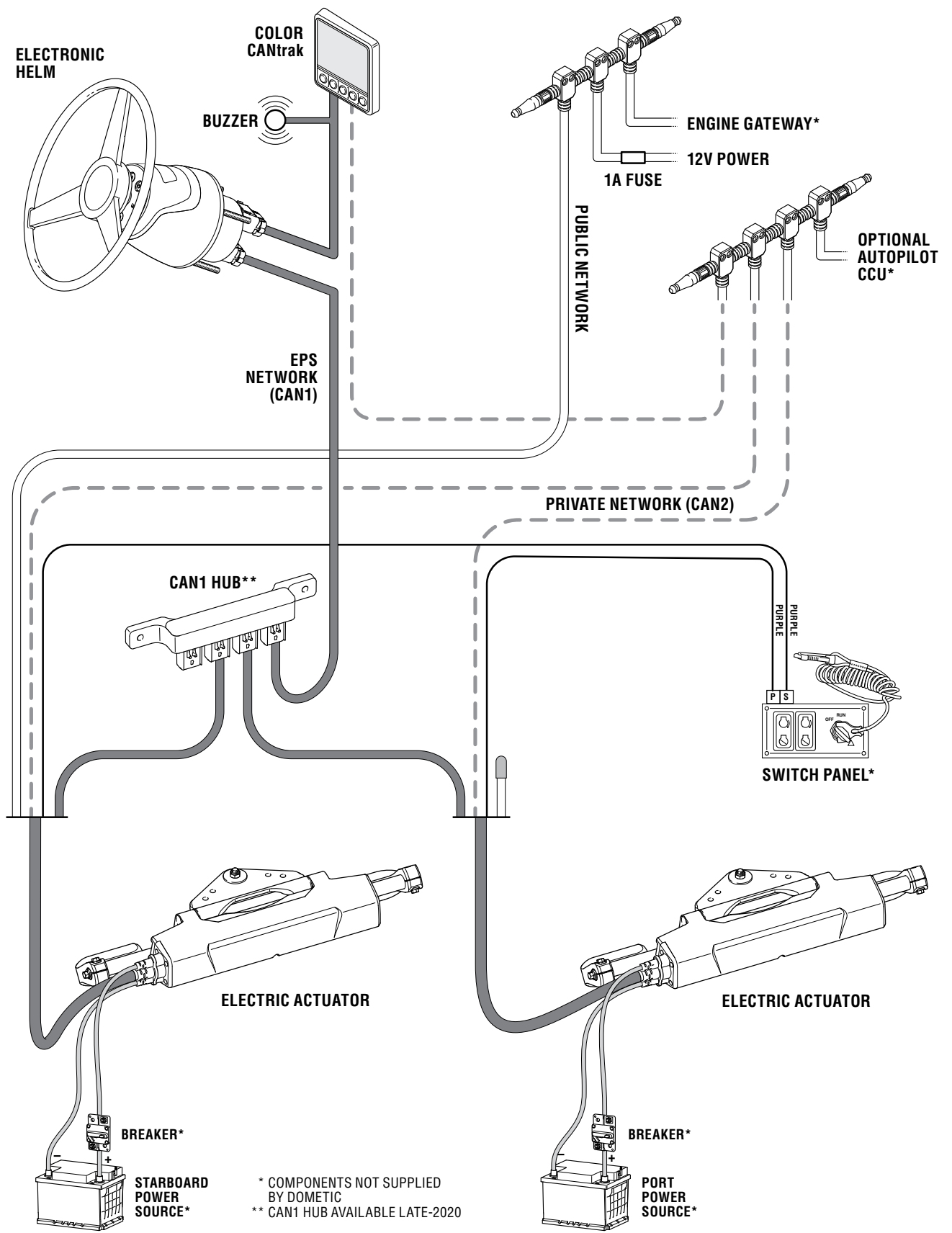

\* COMPONENTS NOT SUPPLIED BY DOMETIC  
 \*\* CAN1 HUB AVAILABLE LATE-2020

Figure 2-1. Optimus EPS system diagram, single station, twin engine.

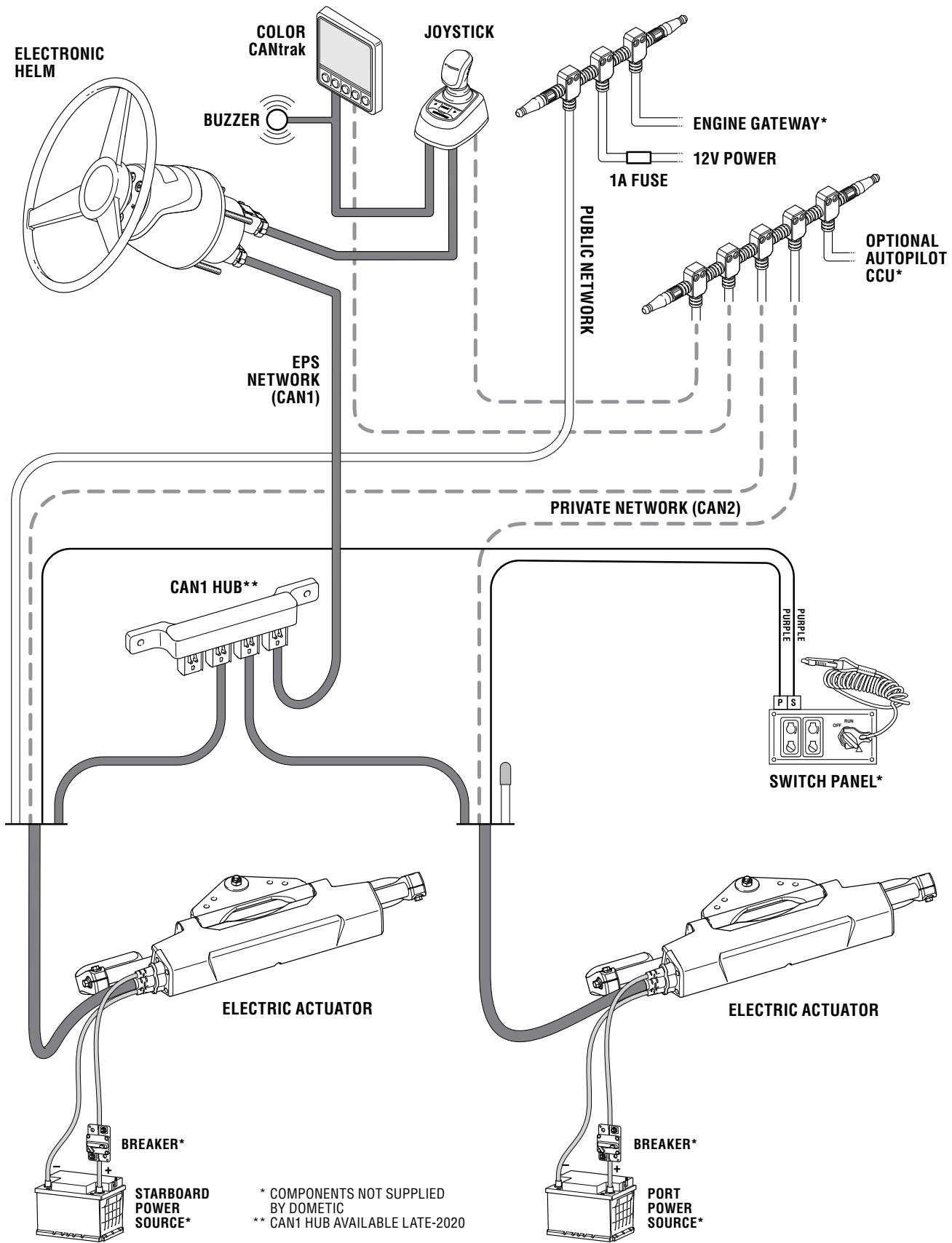

Figure 2-2 Optimus 360 system diagram, single station, twin engine.



# 3 Using Your EPS System

## 3.1 Before first use

Before operating your boat for the first time, take a few moments to:

- Familiarize yourself with the location and function of the steering system components. Review the system overview in section 2 to learn about the components and where to find them.
- Perform a system inspection as shown in section 3.1.1.
- Check the Electric Actuator installation for interference as shown in section 3.1.2.
- Review section 4 to understand the different types of system faults, and how the system handles them. Out on the water in the middle of a fault condition is no time to learn the difference between a danger fault and a warning fault.

### 3.1.1 System inspection



#### **WARNING!**

Failure to comply with these instructions may result in a loss of steering control, which could lead to a collision and/or ejection from the boat, causing property damage, personal injury, and/or death.

Inspect your steering system and engine controls before every use. For your convenience, the inspection steps are summarized on the Quick Reference Guide included in your document package. Always keep this card on your boat. (Contact your dealer immediately if you do not have your QR Guide.)

#### **Procedure:**

##### **1. Verify immediate steering response when turning steering wheel(s).**

Turn the steering wheel slowly to port and starboard and make sure the engine(s) follow the commands. Check at all helm stations.

##### **2. Inspect all steering components, cables, and connections for wear, kinking, and/or signs of damage.**

Check the harness between the actuator and transom for any worn, abraded, or cracked insulation, or any physical damage. Check that the connector at the actuator is tight and properly secured. Check that the fitting at the transom is hand tight, and that all harness bends are smooth and gradual with no signs of kinking or twisting. Check that the actuator shaft is free of mechanical damage or excessive wear.

##### **3. Check for binding, loose, or worn steering components.**

Check that the actuator and harness move freely without any snags or hang-ups through the entire steering range. Actuator motion should be smooth. Any jerkiness in the motion is a sign that something is wrong and it should be checked. Check that the helm motion is smooth with no mechanical play in the helm or wheel hub. Don't forget to check any additional helm stations.

#### 4. Verify shift and throttle response at all control levers.

Check that all control levers operate freely and cause the engines to shift accordingly. Put the engines in neutral idle mode and confirm that the throttle responds correctly and returns to idle. If your engine's shift and throttle are cable operated, check all cables for signs of wear or damage. Check that all linkages and cables move freely and are not binding or corroded.

#### 5. Verify that no alarms or warnings are shown on the CANtrak display.

If any warnings are present, follow the instructions on the display.



#### **WARNING!**

Do not operate the boat if any component (including CANtrak display) is not in proper working order. It may result in a loss of steering control, which could lead to a collision and/or ejection from the boat, causing property damage, personal injury, and/or death.

---

### 3.1.2 Interference check



#### **NOTICE!**

Failure to perform these checks may result in damage to the Electric Actuator, which could affect operation of the steering system.

Perform the steps below to confirm there is no interference between actuators, splashwell, engines, tie-bars, or any combination of these parts. At each step check that the harnesses are moving freely with no rubbing or binding, and that the bend radius is never less than 3.5" (90 mm). Steer slowly while performing these checks, and always have someone watching at the transom. The tilt operation is where the potential for actuator damage is highest, so pay attention when tilting up.

1. With engine(s) fully tilted down, turn steering wheel slowly from lock to lock and confirm no interference occurs through the travel.
2. Carefully tilt engine(s) up. Check for clearance to the underside of the Electric Actuator and the transom and engine mounting bolts. If it appears the actuator will contact any fixed parts, stop tilting immediately to avoid damaging them. Your dealer may need to install a tilt limit.
3. With engines tilted up, turn steering wheel slowly from lock to lock and confirm no interference occurs through the travel.

#### **Multi-engine boats only:**

4. Tilt the engines back down, then trim the port engine(s) fully down and the starboard engine(s) fully up. Steer lock to lock and confirm no interference occurs. Reverse the trim position of the engines and repeat.
5. Check that all combinations of trim/tilt and steering do not cause interference.



#### **WARNING!**

If any interference occurs return the boat to your dealer immediately for corrective action.

## 3.2 System operation

---

Always perform the system inspection described in section 3.1.1 before using your boat.



### **WARNING!**

Do not operate the boat if any component is not in proper working order. It may result in a loss of steering control, which could lead to a collision and/or ejection from the boat, causing property damage, personal injury, and/or death.



### **WARNING!**

Do not operate your boat without a functioning CANtrak display.

Optimus EPS with Electric Actuator is designed to operate much like a conventional hydraulic system. When the engine ignition is on, the system is active at all helms. Turn any steering wheel and the actuators will steer the engines. On a multi-station boat there is no need to transfer control from one helm to another.



### **CAUTION!**

Keep magnets away from the helm and actuator. They may interfere with operation.

Like a conventional hydraulic system, steering input from each helm is added cumulatively, which means it is possible that steering inputs from a second helm can cancel out or exaggerate the operator's inputs. It is important that all passengers, and especially children, are instructed not to touch the helms unless specifically requested to take control.



### **WARNING!**

Do not attempt to move from one helm station to another while the boat is under way. Place engines in neutral and ensure the boat is stationary before moving to another station.



### **NOTE**

All steering helms are active when Optimus EPS is turned on. This is the same as you would find on a conventional hydraulic steering system.

---

### 3.2.1 First time operation

We recommend you take the boat out for an initial sea trial in calm conditions. Connect the engine ignition lanyard to your PFD or a belt loop and ensure any passengers are securely seated. Proceed carefully to a section of deep, open water at moderate speed. Use the trip to get a feel for the steering response. When in deep enough water, try various maneuvers with the boat at various speeds until you are comfortable operating the boat. Spend some time backing up at slow speed. Once you are familiar with the operation and steering response, run the boat in a safe, normal fashion and enjoy using the most advanced outboard steering system available today.

## 3.3 CANtrak display

---

The Optimus CANtrak display has an easy to navigate menu system, adjustable backlighting for night use and includes a cover to protect it from the sun when not in use.



Figure 3-1. CANtrak display, All Helms Active screen.

### The CANtrak display serves these purposes:

1. Displays the current system operating conditions.
2. Handles system faults:
  - a) Displays system warnings in case of a system fault.
  - b) Sounds an audible alarm in case of a system fault.
  - c) Instructs the operator what to do in case of a system fault.
3. Permits changes to the basic system settings.
4. Provides system and diagnostic information.







---

### 3.3.1 CANtrak display navigation

The five buttons at the bottom of the unit are used to select various actions. The five boxes at the bottom of the display screen indicate the legend for each button. These legends vary based on what is on the screen.

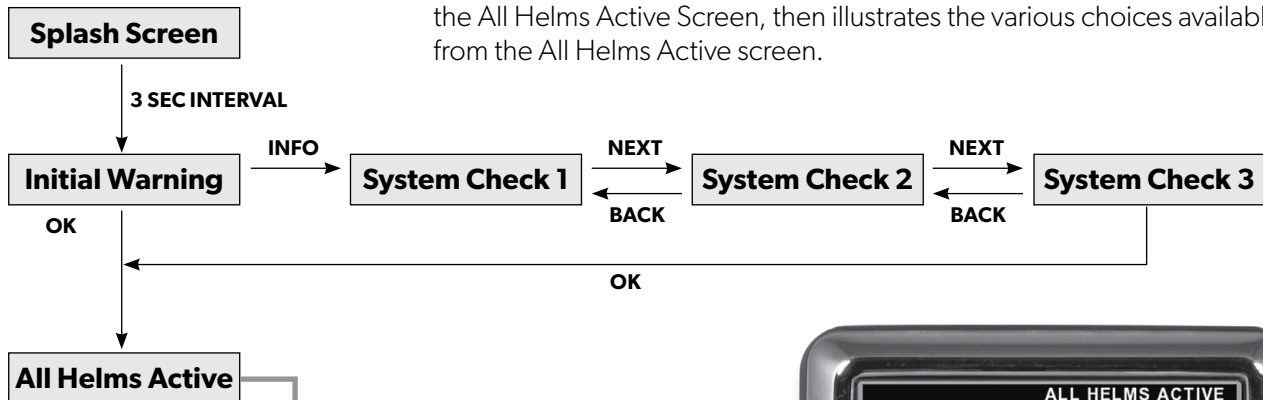

Figure 3-2. Navigation buttons and legend.

<b>WORD OR SYMBOL</b>	<b>IDENTIFIES A FUNCTION OR SETTING</b>
	Moves the cursor up the screen to the next item.
	Moves the cursor down the screen to the next item.
	Enters the sub-menu at the cursor location.
	Reduces the setting of the selected item.
	Increases the setting of the selected item.
<b>OK</b>	Accepts a given statement or condition and advances to the next screen.
	Returns to previous menu.
<b>Save</b>	Saves change and returns to previous menu.

### 3.3.2 CANtrak display map — All Helms Active (normal steering mode)

The following diagram shows the progression from the Splash Screen to the All Helms Active Screen, then illustrates the various choices available from the All Helms Active screen.



MENU

Maintenance – Diagnostic and maintenance functions.

Settings\* – Set steering parameters such as number of turns and steering effort.

Faults – View active faults.

System Health – View the status of all devices on the network.

✓ Good ⚠ Warning, but operational ✗ Failed ? Not found

Devices – Access product information, such as part number and serial number, for each device on the network.

\* Menu may be deactivated. Contact your dealer.

Figure 3-3. CANtrak display map.

---

### 3.3.3 All Helms Active screen

The All Helms Active screen (also called the Run screen) will be displayed under normal operating conditions after the startup warning has been acknowledged. The screen shows engine RPM, rudder angle, and legends for the Display and Menu buttons.

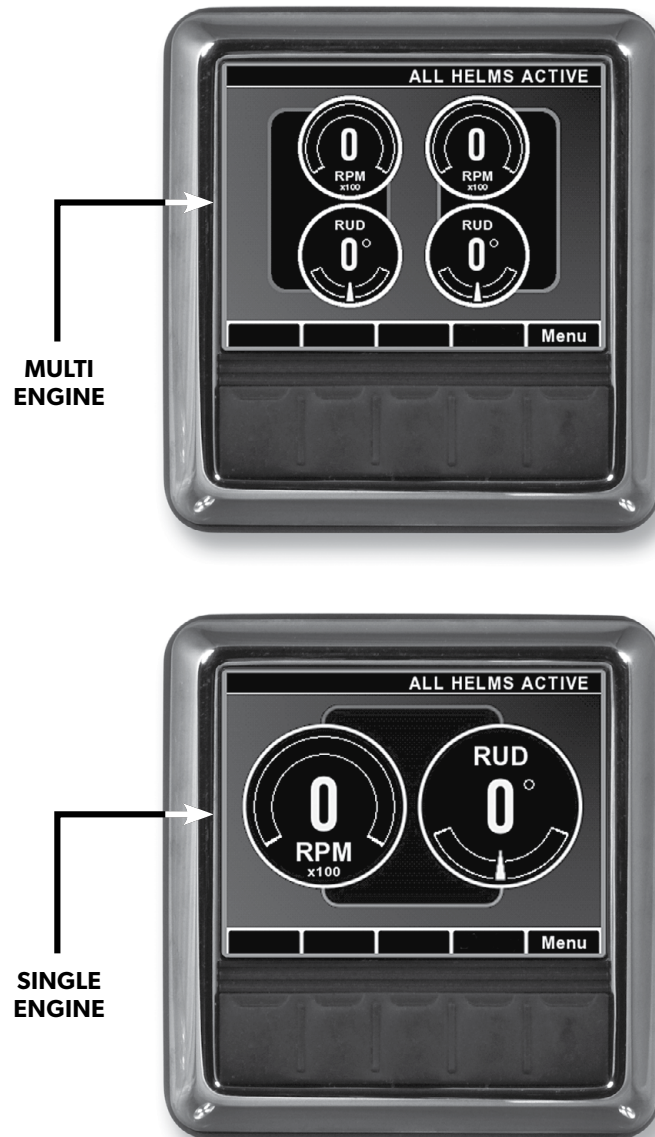

Figure 3-4. All Helms Active screens.

---

### 3.3.4 Steering maintenance screen

The Steering Maintenance screen allows user access to actuator calibration and move functions. We recommend that you use these functions only under the direction of a Dometic technical support representative.

Calibration is required if you used the emergency manual override procedure. See section 6.3.2 for calibration instructions.

The move function is described in section 6.3.5.

### 3.3.5 Settings screen\*

If the boat builder (or dealer) has enabled this menu option, the Steering Settings screen allows adjustment of steering effort and helm turns. To get to the screen, select Settings from the Menu, then select Steering. You will be prompted to save changes when you exit.

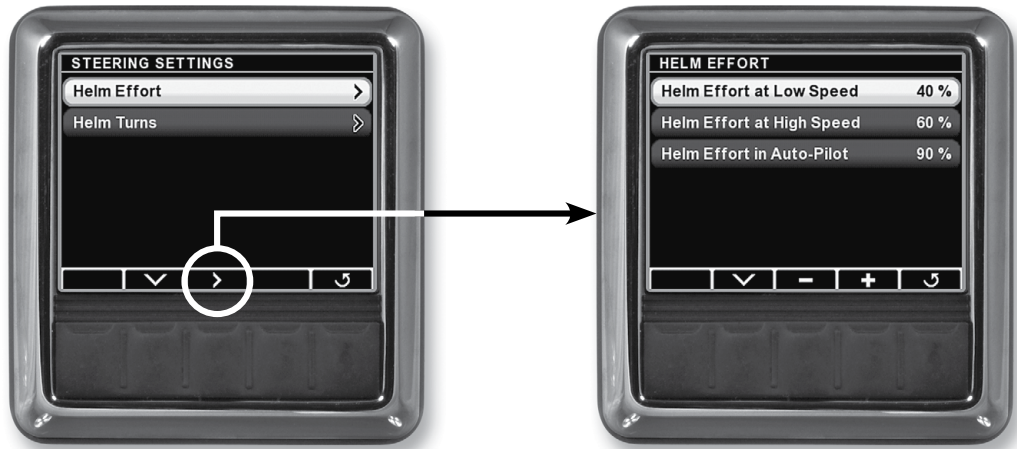

Figure 3-5. Steering Settings.



#### **WARNING!**

Adjusting steering effort or helm turns can significantly impact boat handling. Proceed with caution after making any changes.

#### **Helm Turns at Low Speed**

Sets the number of turns (hard-over to hard-over) when the vessel is running at low speeds. The range is 3.5 to 8 Turns.

#### **Helm Turns at High Speed**

Sets the number of turns (hard-over to hard-over) when the vessel is running at high speeds. The range is 3.5 to 8 Turns.

#### **Helm Effort at Low Speed**

Sets the steering resistance when the vessel is running at low speeds. It is adjustable between 1 and 100.

#### **Helm Effort at High Speed**

Sets the steering resistance when the vessel is running at high speeds. It is adjustable between 1 and 100.

#### **Helm Effort in Auto-Pilot**

Sets the steering resistance when autopilot is engaged. To prevent accidental course corrections with the wheel this should be set slightly higher than the high speed effort. It is adjustable between 1 and 100.

*\* May not be available on all installations. Contact your builder or dealer.*



### 3.3.6 Speed sensitive steering

A key advantage of Optimus electronic power steering is the ability to change steering parameters as boat speed changes. Both the steering effort and helm turns are smoothly adjusted between their low and high speed settings as the boat speed changes. Figure 3-8 illustrates how this works.

Low and high boat speed is defined by engine RPM using values determined by the boat builder or the dealer that installed the system. These are not user adjustable.

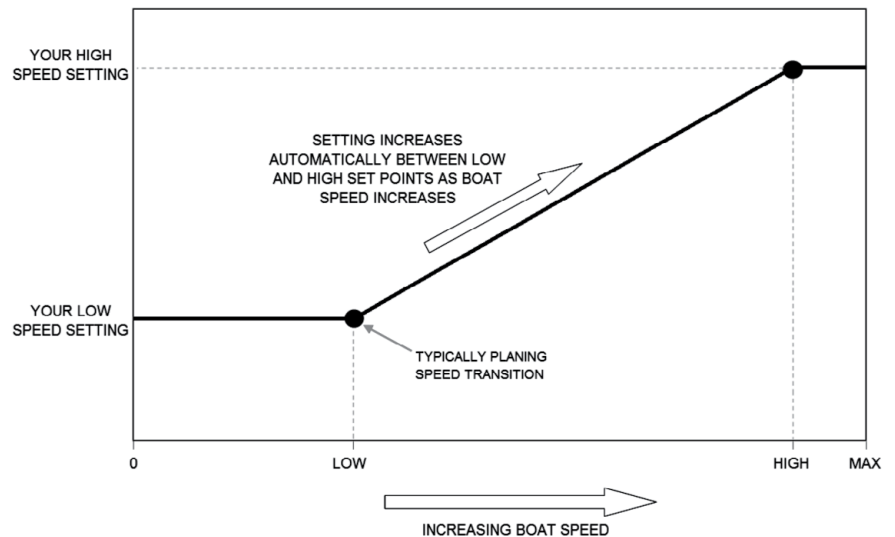

Figure 3-6. Change of helm settings with speed.

#### High Speed Rudder Limit

The boat builder or dealer may have set a high speed rudder limit in order to keep the vessel in a comfortable operating envelope and prevent aggressive maneuvers at high speed. If this is the case you will find that your steering angle is progressively limited as boat speed increases.

### 3.3.7 Display brightness

You can adjust the display brightness according to ambient lighting conditions. To access the brightness setting, press **Menu** from the All Helms Active screen, then press **Display**. Use the **+** and **-** buttons to adjust the brightness.

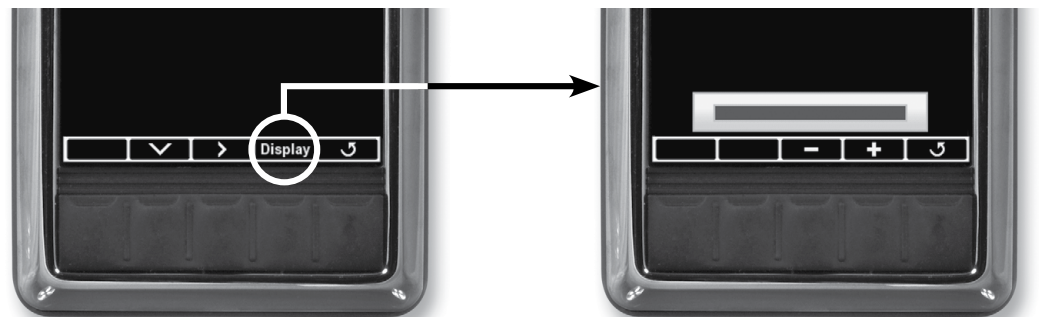

Figure 3-7. Display brightness settings.

## 3.4 Autopilot operation

In addition to seamless compatibility with the innovative Dometic SeaWays autopilot and SeaStation virtual anchor, Optimus EPS is designed to interface with several autopilot controllers. See the documentation with your autopilot system for specific model compatibility and user instructions. If your boat is equipped with SeaWays or SeaStation, refer to the instruction manual (Book 67) for user instructions.



### WARNING!

Read and understand the autopilot operation instructions before engaging the autopilot mode. Do not leave the helm unattended while the autopilot is engaged.

When autopilot is engaged:

- The CANtrak run screen will display a notification as shown in figure 3-8.
- The steering effort at the helm is increased to prevent inadvertent use. This resistance may be user adjustable, depending on how the builder or dealer set up your system. See section 3.3.5.
- Turning any steering wheel will override the autopilot and return control to the helm. Steering resistance will return to normal until the autopilot re-engages. See your autopilot user's manual for specific behavior during an override.

The Title Bar will display "Autopilot Mode" when the autopilot is engaged.



Figure 3-8. Autopilot mode screen.

## 3.5 Joystick operation (if so equipped)

The joystick is the primary user interface for the optional Optimus 360 Joystick Control System. It offers the ultimate control of the vessel for docking and maneuvering at slow speeds and is especially useful in confined or difficult circumstances. It is intuitive to use, as the boat follows the actions of the handle. This section of the manual gives a detailed description of all of its capabilities and how to get the maximum benefit from this powerful feature. The Optimus 360 Joystick Quick Reference Guide, provided with the system, gives summary and reminder information on its operation and should be kept on the vessel at all times.



### NOTE

While the joystick is active the turning resistance of the steering wheel will increase to remind the user that the helm is disengaged.

### 3.5.1 Joystick fundamentals



Figure 3-9.

#### Handle motion

The handle can be moved in any direction or rotated left or right. When released the spring-loaded joystick will return to center and put the engine in neutral at idle throttle.

Moving the handle away from center or rotating it will cause the engines to shift into the correct gear for the desired motion. Further handle motion in the same direction will apply throttle and provide more thrust in the chosen direction. The joystick is proportional and guided in each axis.

#### Boost button

Increases the power the engines can apply and may be turned on or off at any time. It can be very handy when handling the boat in wind or current. The system will remember the boost mode status so if it is left on, it will be on again next time the joystick is activated.

A blue LED on the Boost button will illuminate when in boost mode.

#### Take Command button

Activates the joystick and allows the joystick to take control of the vessel. To take control with the joystick, press **Take Command** with both control head levers in the neutral position.



### NOTE

If your boat has Yamaha engines you can only take command with the joystick at an active control station. To transfer to joystick control at another station, you must first press the Yamaha **Station Selector** button to activate the control station.

To transfer control back to conventional shift and throttle, refer to section 3.5.4.

The LED on the Take Command button is used to indicate joystick status:

LED State	Joystick Status
Off	joystick is inactive
Steady blue	joystick has control of the vessel
Slow flashing blue	joystick is initializing rudder and EST system
Alternating red and blue flashing	joystick has control of the vessel, but there is an active non-critical warning fault*
Fast flashing red	joystick has a critical fault* and is awaiting transfer of control to a control head
Steady red	joystick has a critical fault* and is not available for operation

\* See section 4 for fault handling information.

Table 3-1.

## A and C Buttons

Used with the optional SeaStation boat positioning system (see separate instructions if so equipped).

### Operation fundamentals

The levers on the active control head must be in the neutral position before a joystick may take command of the system.

1. The joystick has three primary operational modes (see figures next page):
  - a) **Forward/Reverse** – engaged by pushing the joystick directly fore/aft.
 

Causes the boat to move directly fore and aft. In this mode, the boat can be steered by rotating the handle. Always engage the Forward Reverse Mode by moving the handle directly fore/aft then rotating the handle to steer. Rotating the handle first then pushing fore/aft would enter Rotation Mode and apply a forward correction in rotation mode.
  - b) **Sideways** – engaged by pushing the joystick directly to port or starboard.
 

Causes the boat to move directly sideways. In this mode, the handle can then be moved fore/aft or rotated to correct the vessel's heading or position.
  - c) **Rotation** – engaged by twisting the joystick while it is at center position.
 

Causes the boat to rotate on the spot. A fore/aft handle movement after engaging rotation mode will cause the boat to rotate but with a forward or reverse bias. Always engage Rotation Mode first then apply the desired correction. Pushing the handle fore/aft then twisting would cause the system to enter Forward/Reverse mode with a steering correction.
2. When released, the joystick always returns to the center position, which provides neutral-idle for engines.
3. The joystick is proportional and guided in each axis — the more the joystick is moved, the more throttle is applied.

See the following pages for examples of each of the primary operational modes.



**NOTICE!**

In the event of an engine stall, only the Forward/Reverse mode is available. Restart stalled engine or switch to conventional controls.

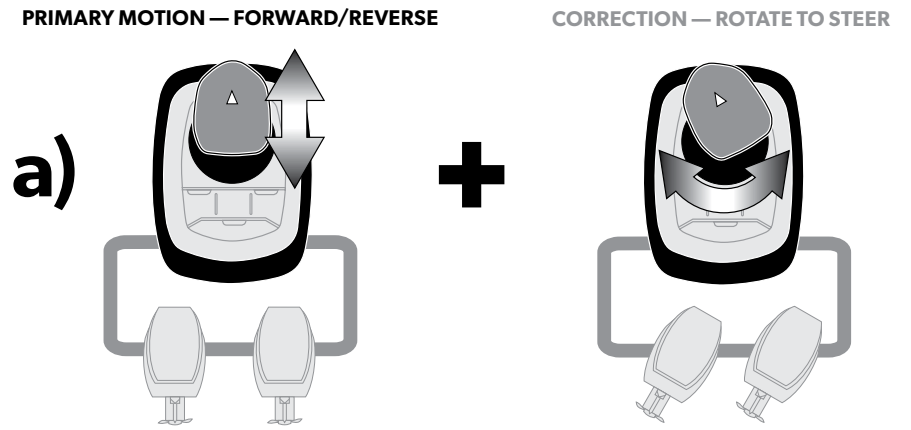

Figure 3-10.

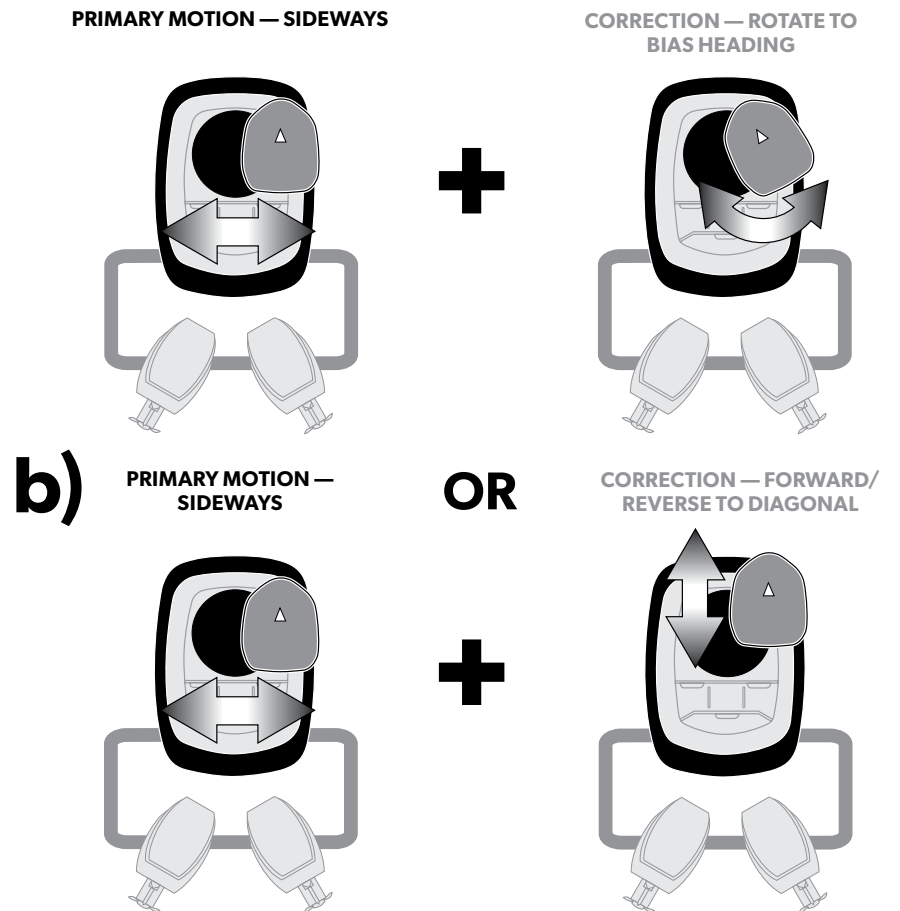

Figure 3-11.

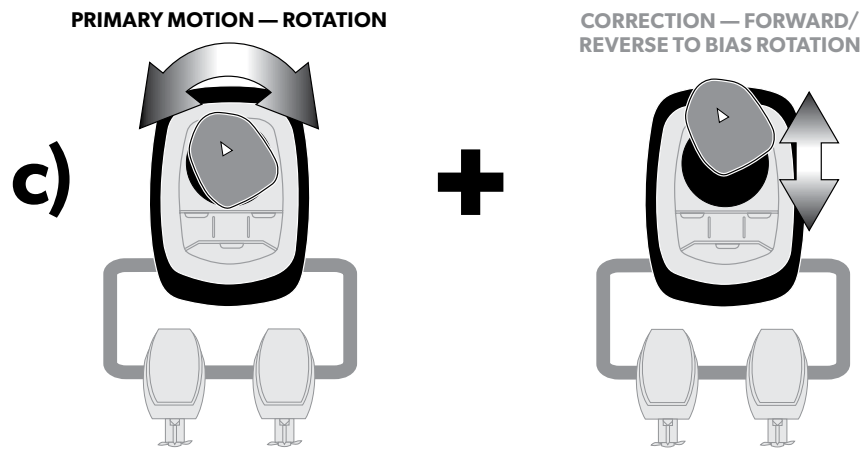

Figure 3-12.

### 3.5.2 Joystick tips

1. Plan out your joystick maneuvers before you approach your target:
  - a) Keep it simple — Minimize diagonal and other complex maneuvers. This allows for better boat correction and control.
  - b) Know your boat's limitations — Be aware of wind and current, and understand the boat's movement delay due to its momentum. Some conditions may prove too strong for your engine thrust.
2. Make it clear to the system what you want to do. Do not make slight movements off of the neutral position. For example: If you want the boat to move to port, move the joystick well along the port axis.
3. Moving the handle port/stbd will move the boat sideways, but will not steer the boat (change heading). Twisting (rotating) the handle steers and rotates the boat (see illustrations previous page).
4. It is recommended to return to the center position when switching between primary operational modes.
5. Practice joystick maneuvers in open water before attempting close quarters docking. This will help you understand the primary operational modes and how they control your boat.
6. There is a momentary shift delay built into the system when returning from any gear activity to neutral. This allows bumping the handle to get a little more motion in the same direction without causing excessive engine shifting. This delay is removed if the action passes the home area in the opposite direction so you can stop the boat immediately if needed.
7. The control head must be active at the helm station with the joystick that will be used and the control handles must be in neutral and idle at that station.

### 3.5.3 Joystick operation examples

#### Example 1

Make the primary action move first and then adjust the boat motion with a secondary joystick motion. Example: the boat is parallel to the dock and you wish to move the boat against the dock. This is like parallel parking a car.

1. Move the boat forward or backward with direct forward or backward joystick motions until the boat is stopped and centered in the location on the dock you wish to approach.
2. Return the joystick to the center position.

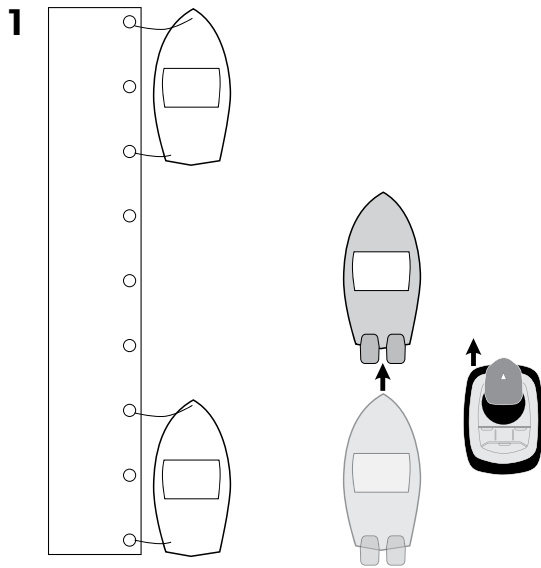

Figure 3-13.

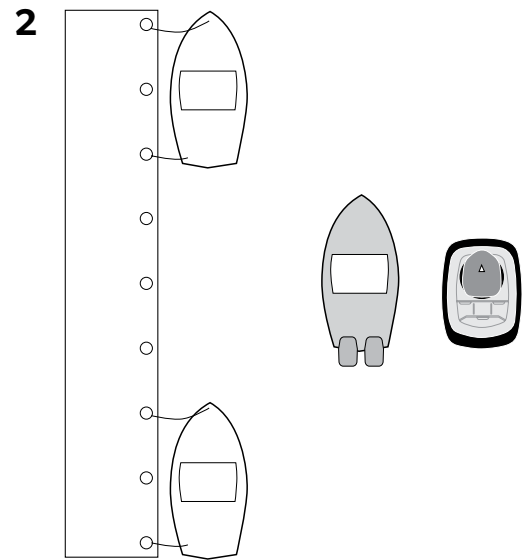

Figure 3-14.

3. Move the joystick directly port to approach the dock.

3a. If the boat does not stay parallel due to wind or current while holding the joystick to the side just rotate the joystick to keep the boat parallel to the dock during the approach.

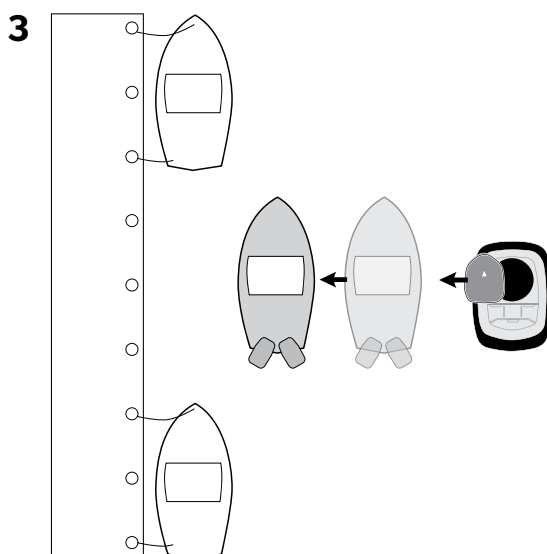

Figure 3-15.

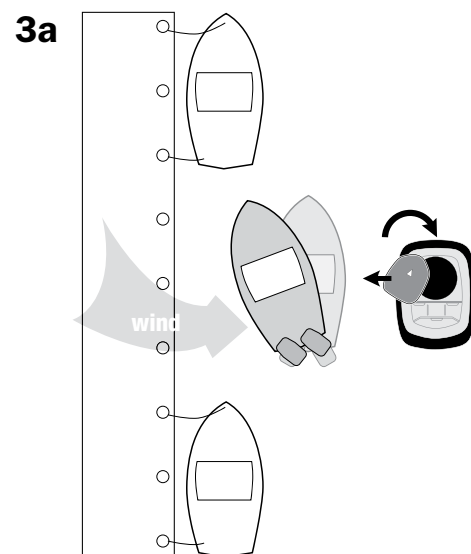

Figure 3-16.

3b. If the boat does not stay centered due to wind or current while holding the joystick to the side, just push or pull the joystick fore aft to correct.

4. Once close to the dock, return the joystick to the center position.

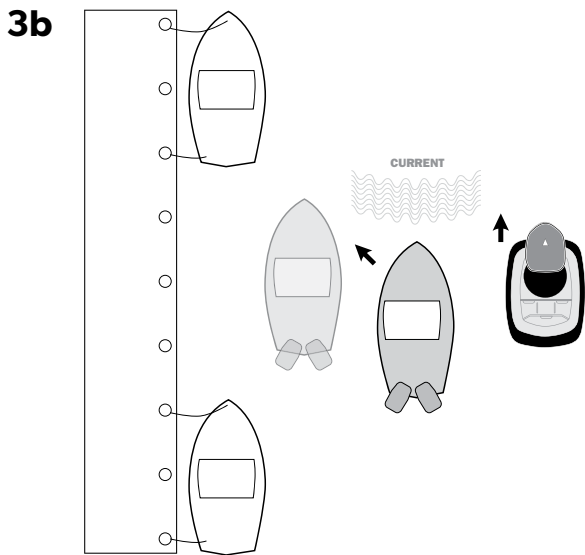

Figure 3-17.

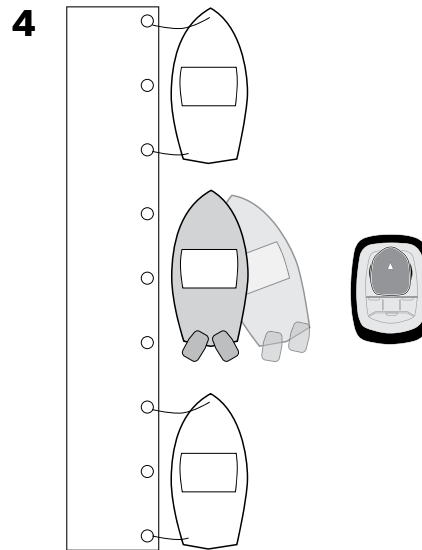

Figure 3-18.

### Example 2

1. Move the boat forward by pushing the joystick forward.
2. With the joystick forward and the boat moving forward rotate the joystick as needed to correct for wind or current. Return the joystick to the home position as you near the slip.

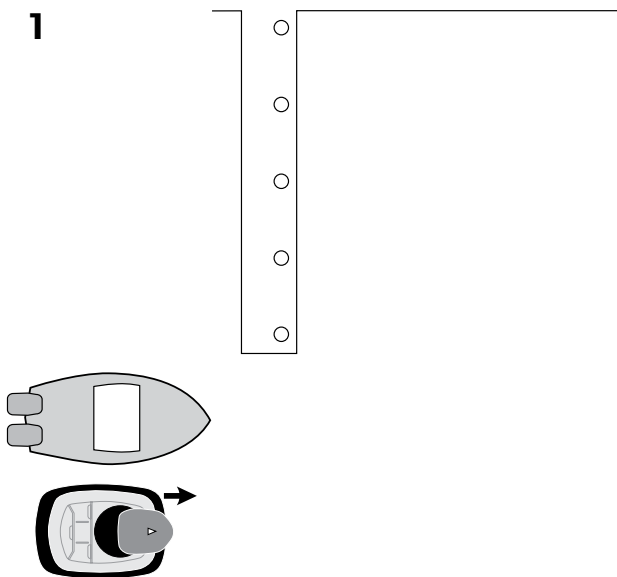

Figure 3-19.

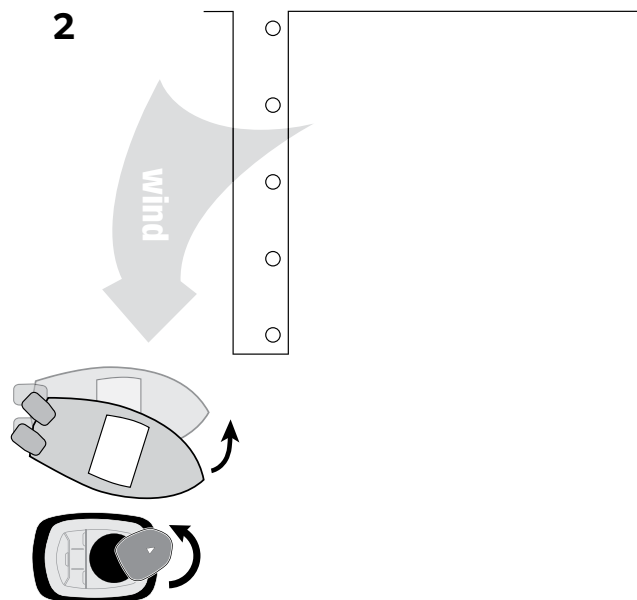

Figure 3-20.



3. As the boat approaches the slip pull the joystick backwards to stop the boat in front of the slip. Return the joystick to the home position when the boat stops.
4. Rotate the joystick to turn the boat and align it with the slip. Use a straight port or starboard move of the joystick if necessary to realign the boat.

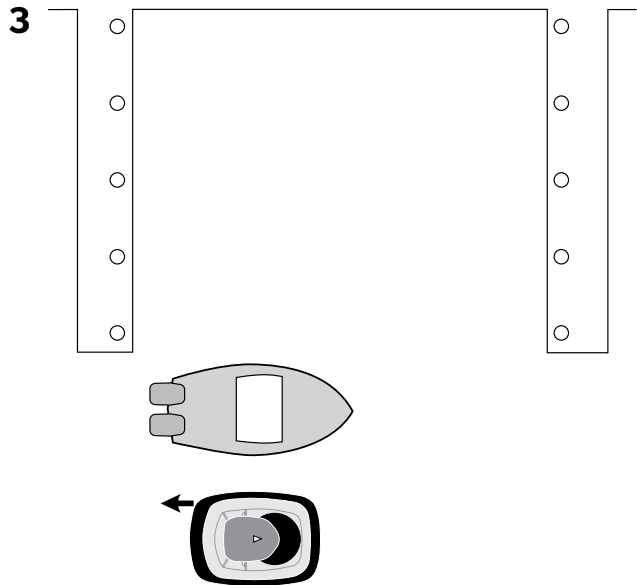

Figure 3-21.

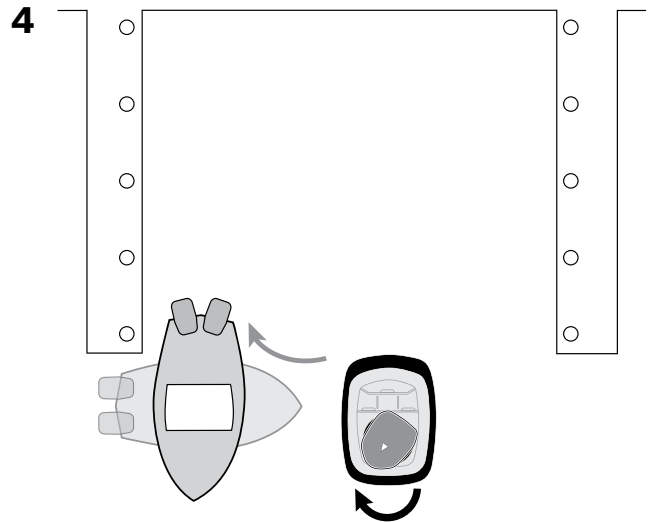

Figure 3-22.

5. Pull the joystick back to move the boat into the slip.
6. A short bump forward on the joystick will stop the boat in position.

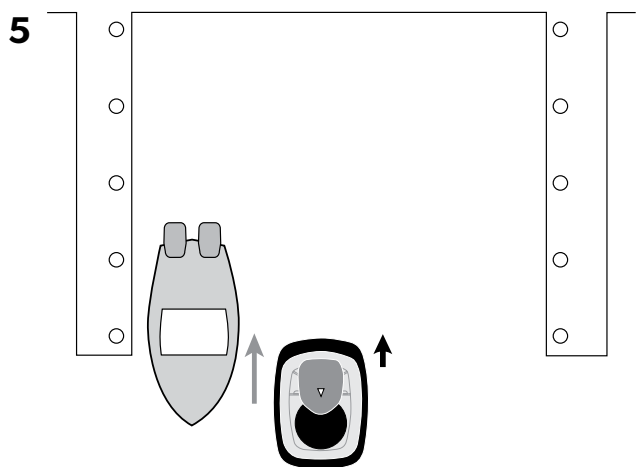

Figure 3-23.

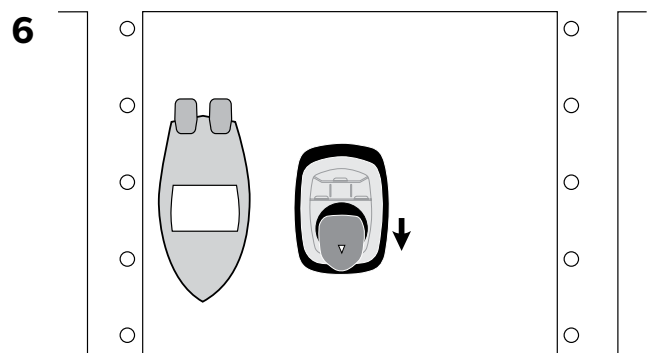

Figure 3-24.

### 3.5.4 Returning to conventional operation

The Optimus 360 joystick control system is designed to work with a variety of different EST systems provided by different engine manufacturers. Each manufacturer has a unique transfer routine to switch from joystick control back to conventional shift and throttle control, shown in the table below.



#### NOTE

The joystick must be in neutral position before transferring control.

Engine Manufacturer	Transfer to control head	Indication of transfer
Evinrude	Press <b>+</b> button on control head	1. Joystick blue lamp(s) turn OFF* 2. Control head lamp(s) turn ON
Mercury	Move the control head levers out of neutral.	1. Joystick blue lamp(s) turn OFF*
Suzuki	Press <b>Select</b> button on station control panel	1. Joystick blue lamp(s) turn OFF* 2. Select LED turns ON
Yamaha	To control head at active station: Move the control head levers out of neutral OR Press <b>Take Command</b> on the active joystick to toggle control back to the control head. To control head at another station: Press <b>Station Selector</b> on the Yamaha panel.	1. Joystick blue lamp(s) turn OFF*  1. Control head lamp(s) turn ON
Yanmar – BY2 Engine	Press Take Command button on control head	1. Joystick blue lamp(s) turn OFF* 2. Control head lamp(s) turn ON

\* A steady red lamp indicates transfer when the joystick is not operational due to a system fault.

Table 3-2.

# 4 System Faults and Hazards

Optimus EPS has robust fault handling and notification systems to assist you in the rare event a fault occurs. Please review this section before using your boat for the first time.



## NOTE

When a serious fault occurs, consider your options. While the system has many features to allow the boat to return to port in a slow and safe manner, local conditions and operator skills may dictate that calling for assistance is the prudent thing to do.

## 4.1 Fault types

---

Do not confuse these fault types with the safety warning types shown in section 1.1. When used to describe a fault these words have a specific meaning.

### **Danger**

A danger fault is a critical system fault which will cause limited or no steering performance. It requires immediate action.

Depending on the nature of the fault, steering will be restricted to one engine or suspended completely. You may need to manually realign the engines and steer the boat using the shift and throttle. In the event of a danger fault, you must return to port or seek assistance immediately.

### **Warning**

A warning fault is a non-critical system fault which may cause the steering speed to be reduced. Even if a warning fault does not adversely affect steering performance it is an indication of a problem in the system and you should correct it as soon as possible.

### **Caution**

A caution fault is a non-critical system fault that will have no effect on system performance. Although it will not adversely affect your steering, it is an indication of a problem in the system that should be corrected. A yellow warning triangle will be displayed on the CANtrak until a technician has fixed the problem.

## 4.2 Fault notification

---

In the event of a danger or warning fault a buzzer will sound and the CANtrak will display a fault screen.

There are two buzzer signals: a continuous tone indicates a danger fault, while an intermittent tone indicates a warning fault. Both require immediate attention. You can silence the buzzer by pressing **Mute** on the CANtrak display.

The fault type will be displayed across the top of the screen, and information and handling instructions are displayed in three zones as shown in figure 4-1.

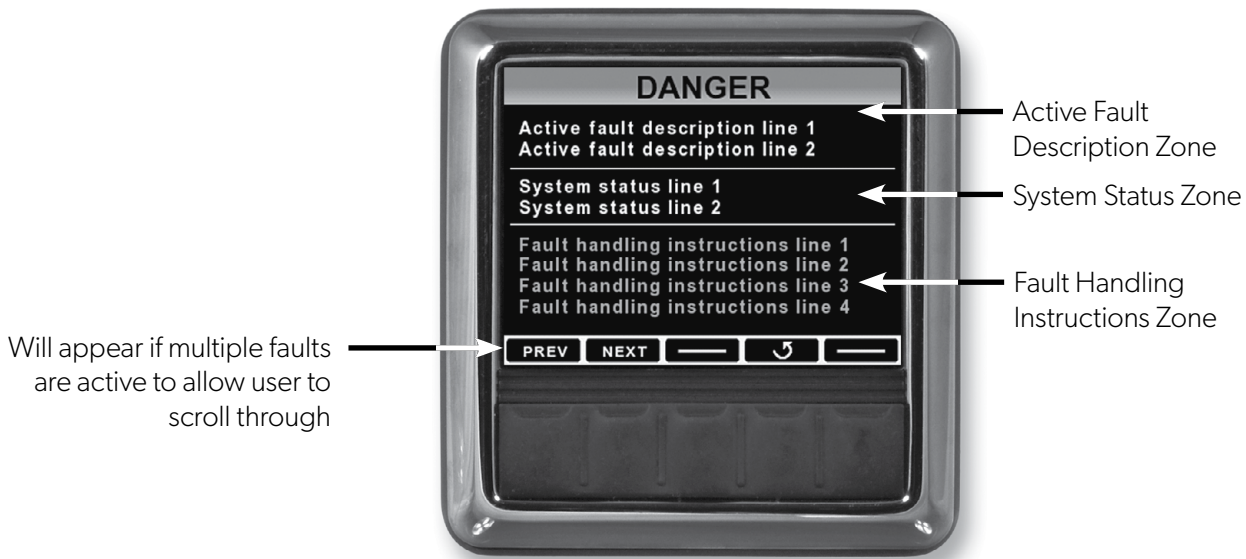

Figure 4-1. Danger fault screen layout.

### Active Fault Description Zone

Provides details specific to the system fault. These will include a brief description of the fault and are primarily for troubleshooting purposes.

### System Status Zone

Displays information about the status of the system and if the system has automatically reacted to the fault.

### Fault Handling Instructions Zone

Provides detailed instructions on how to proceed. In the case of a danger fault, this will instruct the operator what to do and how to proceed should Limp Home mode be required.

## 4.3 Danger fault handling

A danger fault is typically not recoverable, and your actions are generally limited to limping home or calling for assistance. The display will suggest the best course of action based on the nature of the fault. You cannot exit out of the fault screen when a danger fault is present.

### 4.3.1 Limp home

When a danger fault causes limited or suspended steering, the CANtrak may provide instructions on how to enter Limp Home mode. This mode will allow you to “limp home” with reduced performance.

There are two Limp Home modes depending on the nature of the fault.



#### WARNING!

Limp home mode is an emergency override system that may severely limit your boat control. Use it only in an emergency and when unable to call for assistance. Proceed with extreme caution. Ensure all aboard are wearing PFDs and use the engine cut-off lanyard.

## Limp Home Mode 1

This mode occurs when the system cannot steer any of the engines. The CANtrak will instruct you to manually center the engines if necessary (see section 4.3.2) and proceed to port immediately using shift and throttle controls to steer the boat.

Limp Home Mode 1 – No steering is available	
Multiple Outboard Engines	Single Outboard Engine
<p>Steering is disabled.</p> <ol style="list-style-type: none"> <li>Return to port using throttles to steer.</li> <li>If engine(s) require re-centering:               <ol style="list-style-type: none"> <li>Put all engines in neutral.</li> <li>Use tool provided (3/8" wrench).</li> <li>Loosen clamp bolts on BOTH ends of steering actuator shaft.</li> <li>Rotate shaft to reposition steering.</li> <li>Tighten shaft clamp bracket bolts.</li> </ol> </li> </ol>	<p>Steering is disabled.</p> <ol style="list-style-type: none"> <li>Drive towards port.</li> <li>If engine requires re-centering:               <ol style="list-style-type: none"> <li>Put engine in neutral.</li> <li>Use tool provided (3/8" wrench).</li> <li>Loosen clamp bolts on BOTH ends of steering actuator shaft.</li> <li>Rotate shaft to reposition steering.</li> <li>Tighten shaft clamp bracket bolts.</li> </ol> </li> <li>Seek assistance when possible.</li> </ol>

Table 4-1. Limp home mode 1 and instructions.

## Limp Home Mode 2

This mode occurs when one of the steering actuators is not working. This means that one engine in a twin system (or two in a triple or quad system) cannot be steered. The CANtrak will instruct you to move the affected engine away from the others (see section 4.3.2), tilt it out of the water, and proceed to port immediately using the responsive engine(s).

Limp Home Mode 2 – One of two steering actuators is disabled
<p>Affected engine steering is disabled.</p> <ol style="list-style-type: none"> <li>Affected engine must be positioned fully away from others.</li> <li>To move engine manually:               <ol style="list-style-type: none"> <li>Put all engines in neutral.</li> <li>Use tool provided (3/8" wrench).</li> <li>Loosen clamp bolts on BOTH ends of steering actuator shaft.</li> <li>Rotate shaft to reposition steering.</li> <li>Tighten shaft clamp bracket bolts.</li> </ol> </li> <li>Fully tilt affected engine.</li> <li>Return to port on remaining engines.</li> </ol>

Table 4-2. Limp home mode 2 and instructions.

## 4.3.2 Emergency manual steering override



### NOTICE!

If you manually reposition a steering actuator:

- it must be recalibrated before returning to normal operation .  
Recalibration can be done through the CANtrak Maintenance menu, but it is recommended that the recalibration be performed by an authorized dealer whenever possible.
- the support bracket clamp bolts must be tightened to the correct torque before returning the boat to service (see section 5.2.2).

In the event you need to use Limp Home mode, use the following procedure to manually reposition the affected engine(s):



### CAUTION!

Shut off all engines and wear a PFD. This procedure requires you to work at the transom of the boat, and/or in the splashwell. Please take every possible safety precaution.

1. Use the emergency override tool included with your documentation package to loosen the flange bolt that is securing the ground strap to the starboard side of the actuator (step 1 in figure 4-2). If you do not have the tool you will need a 3/8" wrench or socket. Loosen it enough that the ground strap tab will be free to rotate around the bolt when the shaft turns.
2. Use the same tool to loosen both support bracket clamp bolts a (step 2 in figure 4-2).
3. Turn the shaft using the hex-head feature on the port end of the actuator shaft to manually steer the engine as required (step 3 in figure 4-2). Check that the ground strap is not binding or wrapping.
4. Reposition the engine as required, then tighten both support bracket clamp bolts and the ground strap bolt.

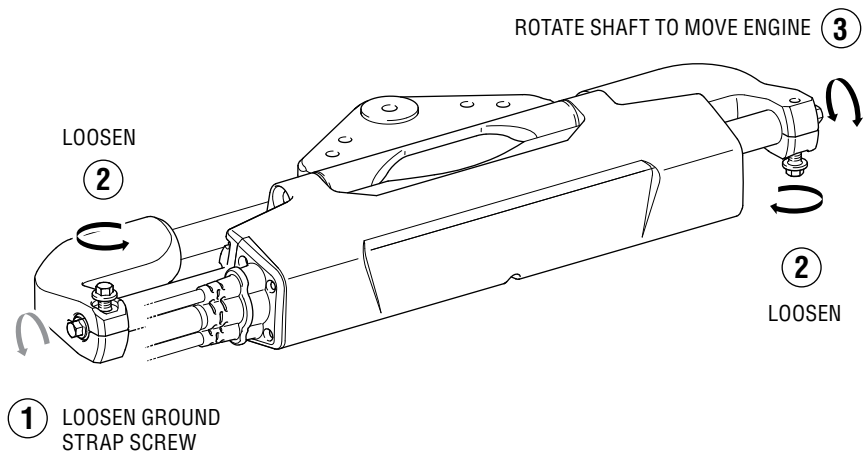

Figure 4-2. Emergency manual steering override procedure.

## 4.4 Warning fault handling

Under a warning fault the system will remain operable. Some faults may cause steering to respond more slowly to steering inputs, so use caution. Although the system may operate normally under many warning faults, you should still return to port and service the system immediately.



### WARNING!

Proceed with caution until the fault is corrected and normal steering operation resumes.

You may exit the fault display screen and return to the All Helms Active screen by pressing the Exit button. A warning icon will flash on the screen (as shown in figure 4-3) until the fault is repaired. In rare cases there may be more than one active warning fault; you can view a list of all active faults by pressing Faults on the display menu.

If the system recovers from the fault (e.g. a low battery warning is resolved by charging the battery) the warning icon will disappear, and the system will resume normal operation.



Figure 4-3. Run screen with system warning.

## 4.5 Loss of CANtrak display

If the CANtrak display is not working, proceed as follows:

1. If you have a second helm station equipped with a CANtrak display, use it to return to port for service.
2. If there isn't a second display on board, carefully check that the steering operates normally, then immediately and cautiously return to port for service.
3. If you have no steering response, you are unable to call for assistance, and you are in an emergency situation, use the Limp Home procedure in section 4.3.1.

*This page left intentionally blank.*



# 5 Installation

## 5.1 Before you start

Installation of the Optimus system must be performed by a Dometic-authorized technician. To ensure proper installation and maintenance of this steering system:

- Familiarize yourself with the system and review the entire installation procedure before you start installing components.
- Make sure you read and understand all the safety information in this manual, and in any other manual included with the system.
- Check that you have all the components and tools you need.
- Determine the location of helm(s) and CANtrak display(s), and ensure you have the correct extension harnesses.
- Plan your harness routing and connections. Ensure you have enough network tees and terminators.

If you need technical assistance, or wish to report an error in our documentation, please contact Dometic technical support.

Email: [seastar@dometic.com](mailto:seastar@dometic.com)

Phone: 604.248.3858



### NOTE

Where a fastener torque is specified in this manual, the standard tolerance is  $\pm 5\%$  unless a range is given.

## 5.2 Electric Actuator

There are several available actuator configurations, shown in table 5-1.

Pivot Plate Orientation	Single and twin-engine applications	Triple- and quad-engine applications	
	No tie-bar bracket	Tie-bar bracket on starboard side	Tie-bar bracket on port side
Standard	EA1000	EA1000 + HA6840	EA1000 + HA6842
Flipped	EA1100	EA1100 + HA6842	EA1100 + HA6840

Table 5-1.

The standard pivot plate orientation is recommended for most applications, while the flipped plate orientation is recommended for most Suzuki applications. Refer to the installation diagrams that follow for detailed selection information.

---

## 5.2.1 Planning

It's important to consider the harness routing when preparing to install the actuator. The actuator harness on all configurations must have enough slack to accommodate both the steering movement and the trim/tilt movement. The minimum bend radius for the harness is 3.5" (90 mm). See section 5.3 for more information on the harness.



### NOTE

On a multi-engine system, write down the serial numbers before installing the actuators and note which is port and which is starboard. You will need this information when configuring the system later, and they may be hard to see once installed.

---

## 5.2.2 Actuator installation

Find the assembly drawing on the subsequent pages that matches your engine application. You will need to refer to it as you follow the installation procedure.



### NOTICE!

Take care not to damage the actuator shaft when handling and installing the actuator. Scratches and dings may result in water entering the actuator and damaging it.

### Procedure

1. Remove any caps, plugs, or screws from the engine's steering arm and tilt tube. Check that the tilt tube and the threaded hole for the tiller bolt is clean and free from rust or burrs.
2. Install the internal tooth terminal of the ground strap to the engine midsection (see section 5.2.3) and hang the strap over the transom, underneath the tilt tube. It is easier to access the midsection mounting hole before the actuator is installed.
3. Thread the adjuster nut (item 10) onto the starboard side of the tilt tube as far as it will go.
4. Liberally grease the support rod (item 9) with a quality marine grease and slide it through the engine tilt tube.
5. Review the assembly drawing to determine the orientation of the actuator (item 13), the tiller bolt (item 2), and self-locking nut (item 1). Grease the tiller bolt and, while holding the actuator in position, fully thread it into the steering arm and through the pivot plate. Install the self-locking nut finger tight to hold the actuator in place. Tighten the tiller bolt to the indicated torque.
6. While holding the head of the tiller bolt with a wrench, tighten the nut (item 1) to the indicated torque.



### WARNING!

Failure to correctly install the tiller bolt and self-locking nut may result in loss of steering, which could lead to a collision and/or ejection from the boat, causing property damage, personal injury, and/or death.

7. Place the stainless steel washers (item 11) and the plastic spacers (items 7 & 8) on the support rod in the order shown in the drawing. To prevent metal-to-metal contact, use only the supplied plastic spacers.

**NOTICE!**

Incorrect orientation of support rod spacers may result in reduced or non-symmetrical steering range, leading to an inability of the system to calibrate.

8. Install the shaft keys (item 3) into the support rod, then slide the support brackets (item 12) onto the support rod and the actuator shaft. Fasten the brackets to the support rod using the washers (item 5) and nuts (item 4) and tighten to the indicated torque.
9. Tighten the two clamp bolts (item 6) to secure the support brackets to the actuator shaft. Tighten to the indicated torque.
10. Eliminate the free play in the support rod by turning the adjuster nut (item 10) counter-clockwise by hand until snug. Do not use a tool to tighten. Lock the adjusting nut in place by tightening the clamp screw to 40-50 in-lb. Do not tighten the clamp until you have tightened all fasteners to the correct torque.

**WARNING!**

Failure to tighten fasteners to the correct torque may result in loss of steering, which could lead to a collision and/or ejection from the boat, causing property damage, personal injury, and/or death.

11. Complete the ground strap installation. See section 5.2.3.
12. Install the grease fittings (supplied in the hardware kit) into the holes in the support brackets (item 12). Use a grease gun to add grease slowly until a small amount begins to squeeze out from the bracket. Wipe off excess.

ENGINE MANUFACTURER	YEAR	MODEL	ACTUATOR	NOTE
<b>YAMAHA</b>	2010 TO DATE	F150—F300 4.2L V6	EA1000	See below
	2010 TO DATE	F350 5.3L V8	EA1000	See below
<b>MERCURY</b>	2019 TO DATE	ALL 150+ with CMS	EA1000	See below
<b>HONDA</b>	2010 TO DATE	BF150—BF250	EA1000	See below
<b>SUZUKI</b>	1996 TO DATE	DF150—DF350	EA1100	See below

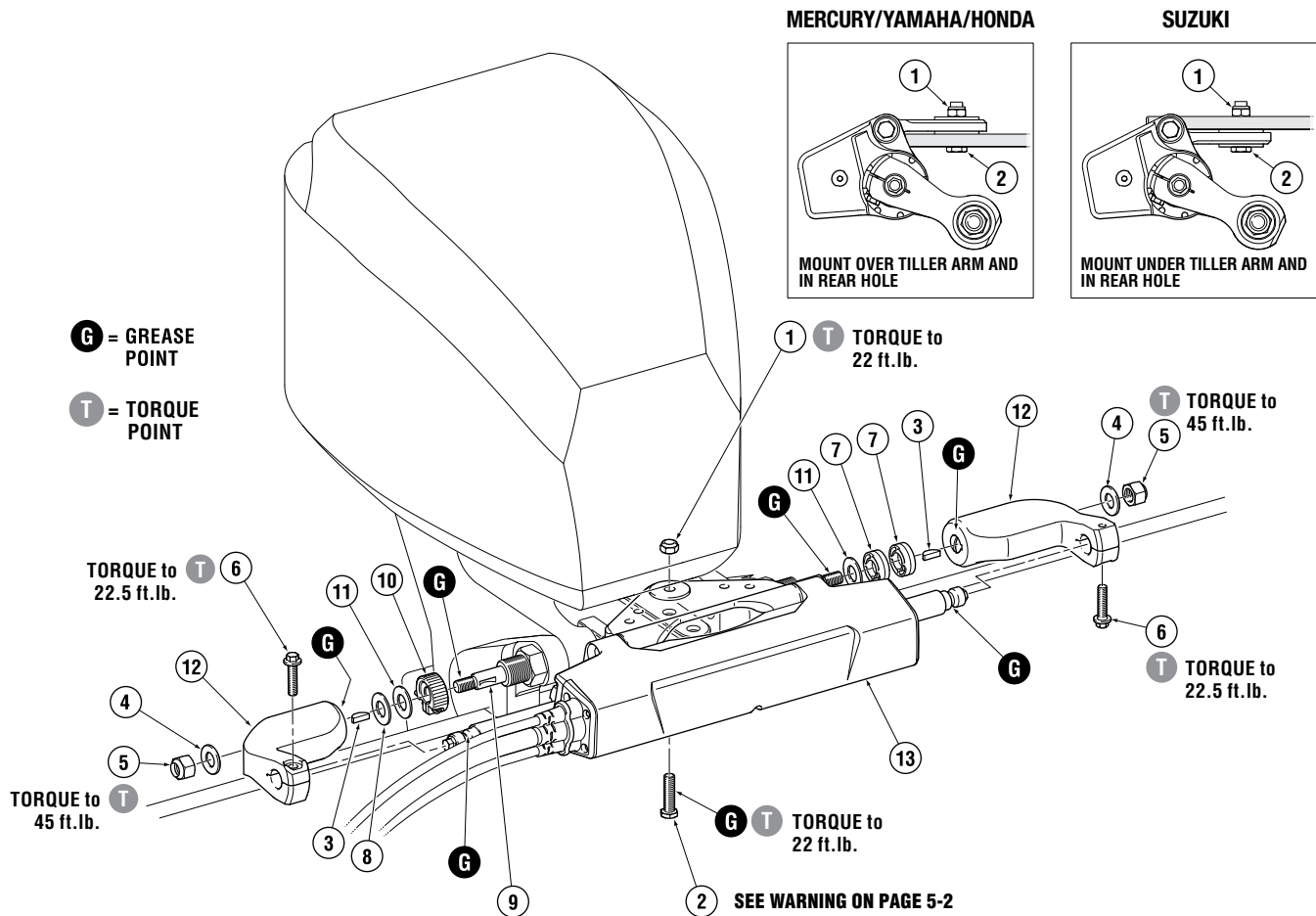

Figure 5-1.

ITEM	PART #	QTY	DESCRIPTION
1	113529	1	Nut, 3/8" NF Nylok® SS
2	113225	1	HHCS 3/8" UNJFX 1.35 HSS
3	260130	2	Key, Support Rod
4	202027	2	Washer, Flat, 1/2" SS
5	192126	2	Nut, 1/2" NF Nylok® NI Plate Br
6	351166	2	Screw, flange, 5/16"
7	995876	2	Spacer, Thick
8	996689	1	Spacer, Thin

ITEM	PART #	QTY	DESCRIPTION
9	351154	1	Support Rod
10	828085	1	Adjusting Nut & Screw, SS, Teflon Coated
11	202300	2	Washer, Flat, 5/8" SS
12	351167	2	Support Brackets
13	EA1XXX	1	Electric Actuator

### 5.2.3 Ground strap installation

You must install the ground strap on the Electric Actuator to reduce the risk of corrosion from stray currents. Refer to the installation diagram and observe the following guidelines:

- Install the ground strap to the actuator on the starboard side, the same side as the harness cable exit.
- Route the ground strap under the tilt tube and fasten the loose end of the strap to the midsection steering bracket holes using the correct fasteners.



#### NOTICE!

Incorrect routing of ground strap may cause entanglement with moving components during steering maneuvers.

- Ensure there is enough slack in the ground strap to allow the engine to pivot freely in all trim and tilt positions, and throughout the steering range of the engine.

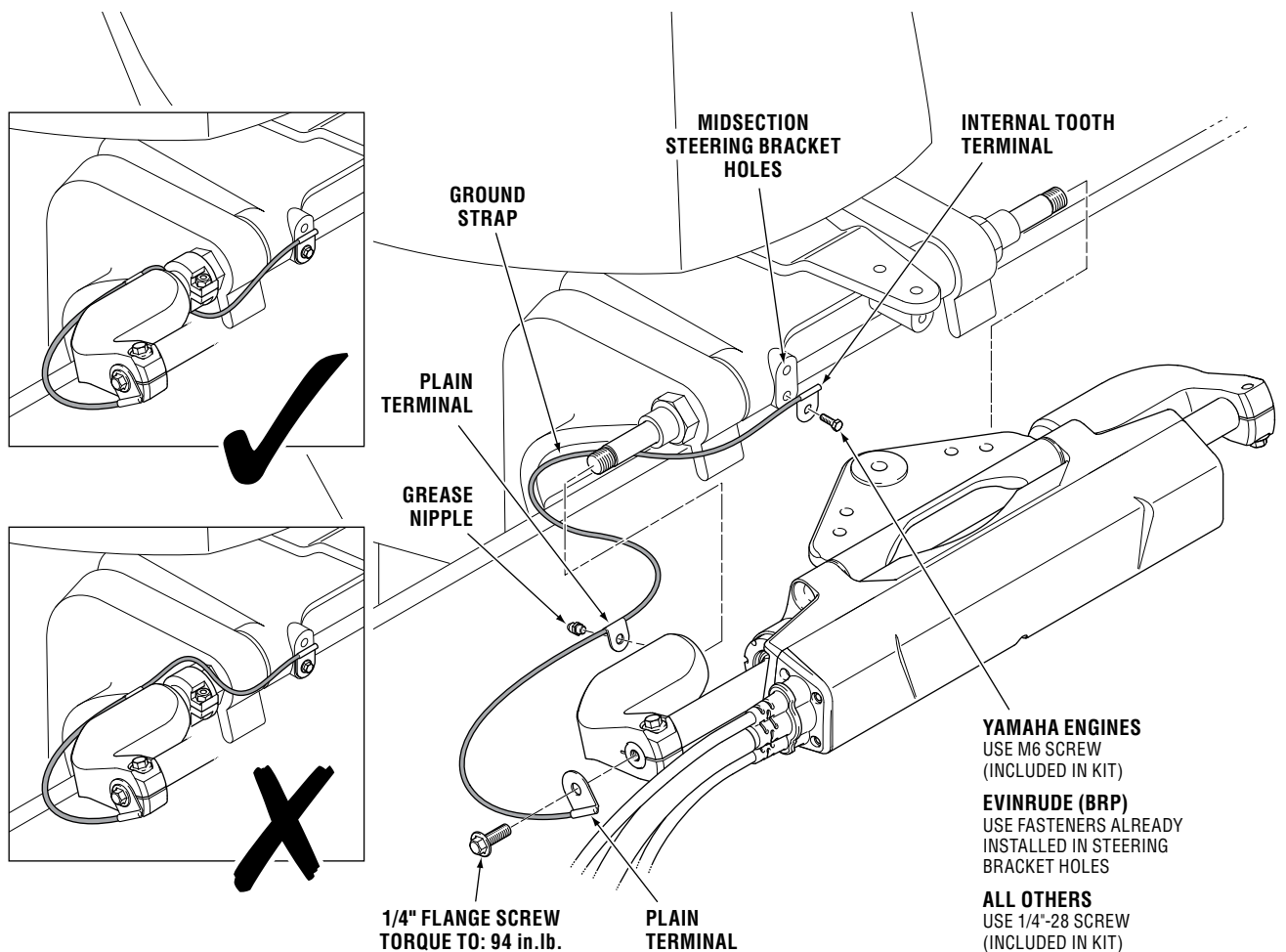

Figure 5-2. Ground strap installation.

## 5.3 Actuator harness

This section deals with the selection and physical installation of the actuator harness. Harness connections are shown in section 5.6.



### CAUTION!

The harness is critical to the operation of the actuator. Ensure installation complies with all requirements of section 5.3 and its subsections. Check that all harness bends are smooth and gradual with no signs of kinking or twisting prior to operation.

### 5.3.1 Planning

The actuator harness, ordered separately from the actuator, is a bundle of three cables: two DC power supply cables and a communications cable with multiple pigtails.

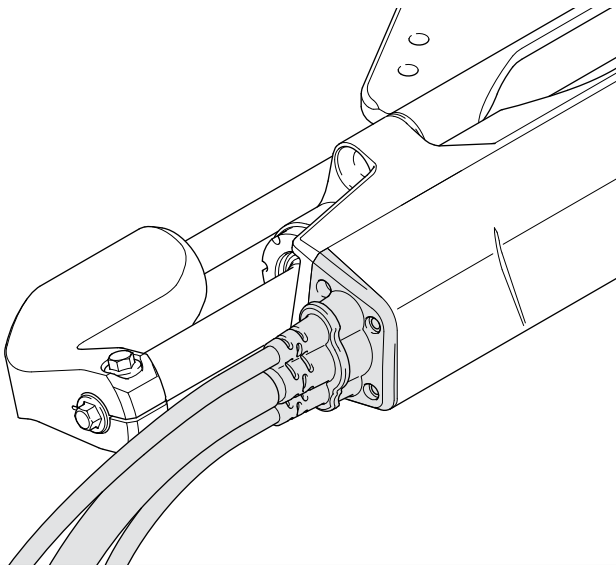

Figure 5-3. Straight actuator harness.

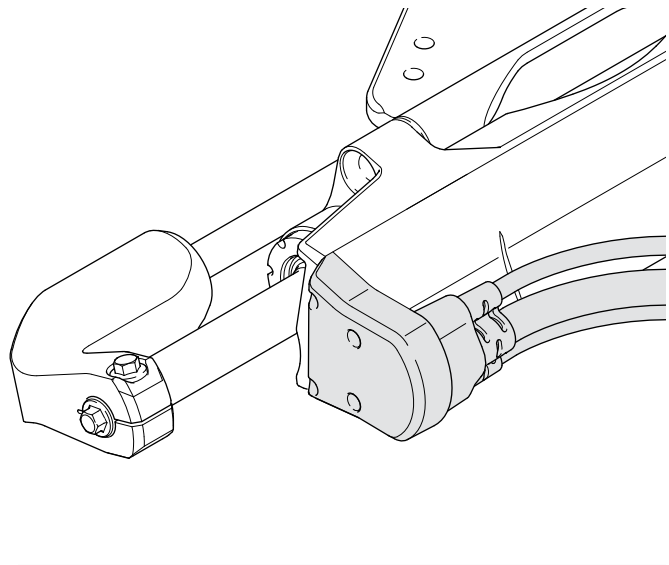

Figure 5-4. 180° actuator harness.

The harness is available with different CAN1 lengths, and in straight and 180° connector styles, to suit your installation requirements. Not all parts of the harness are the same length; table 5-2 shows the length of each component of the harness. When determining which harness to order, consider:

- Two harness styles are available for the actuator in order to meet the minimum bend radius of the cables. The straight harness is for boats with tight clearance to the bottom of the splashwell and the 180° harness is for boats with tight clearance to the side of the splashwell. The splashwell clearance requirement for the two harness styles are shown in figure 5-5 and figure 5-6.
- The longer harnesses are designed for single-engine applications in which the helm station can be reached without extending the CAN1 harness.
- In multi-engine applications you will need to use a CAN1 hub (available late-2020) or a Y-harness to join both CAN1 harnesses together at the aft of the boat. You may need to use different harness lengths for the port and starboard actuator if you locate the hub/Y-harness on one side of the boat. See section 5.6 for more information.

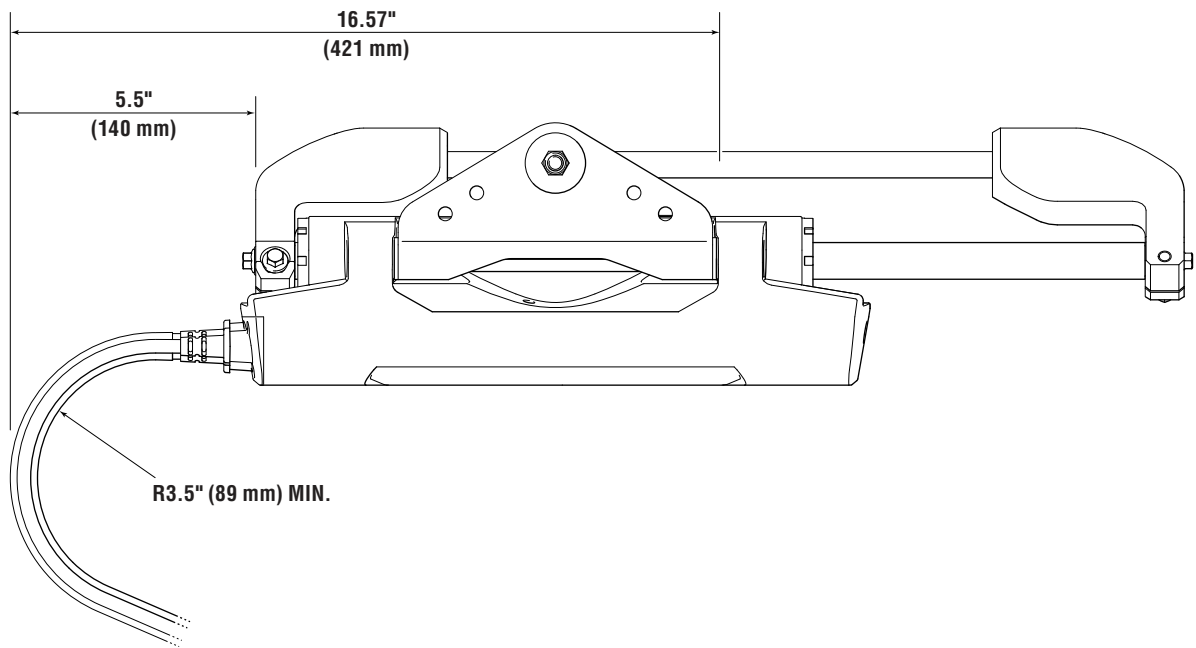

Figure 5-5. Minimum clearance for straight actuator harness.

The 180° actuator harness exits out toward the port side of the actuator, wrapping around the front of the actuator housing. This is useful for boats with limited splashwell side clearance. Be sure to check for adequate splashwell depth when using the 180° harness as it protrudes farther out from the front of the actuator.

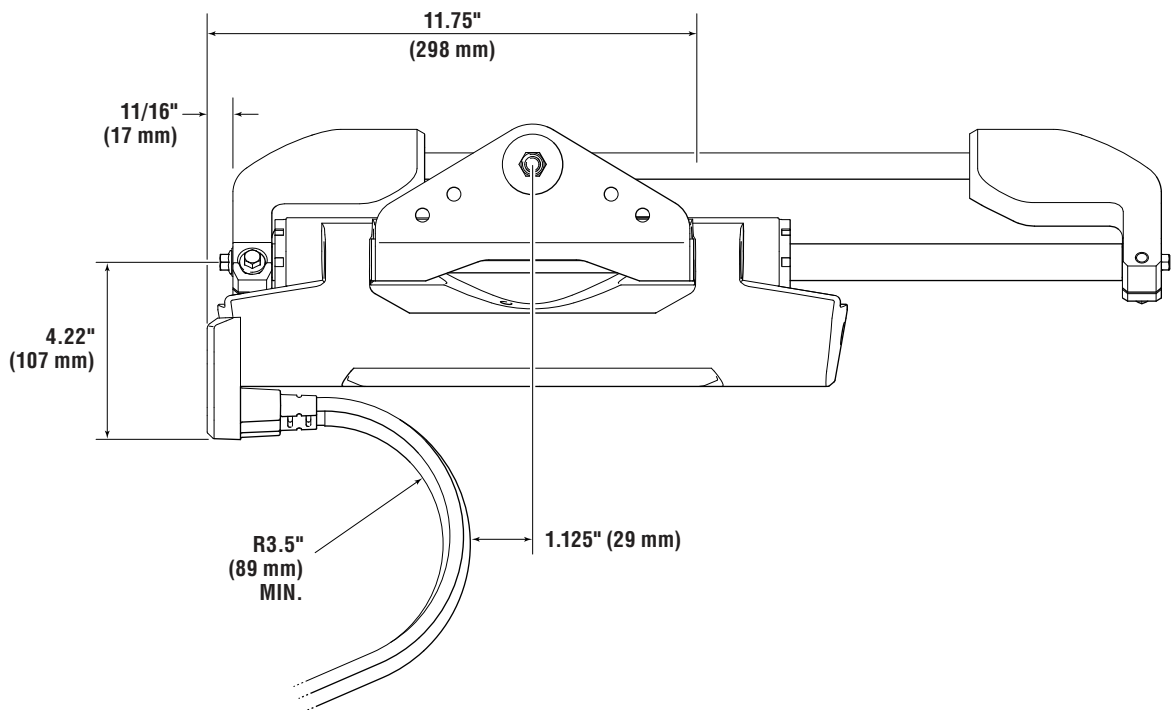

Figure 5-6. Minimum clearance for 180° actuator harness.

Nominal Length	Part No.	Style	Harness component length, ft (m)				
			Battery	Ignition	CAN1	CAN2	CAN3
12'	CM30012	Straight	12 (3.6)	30 (9.1)	12 (3.6)	12 (3.6)	12 (3.6)
18'	CM30018	Straight	12 (3.6)	30 (9.1)	18 (5.5)	18 (5.5)	18 (5.5)
12'	CM31012	180°	12 (3.6)	30 (9.1)	12 (3.6)	12 (3.6)	12 (3.6)
18'	CM31018	180°	12 (3.6)	30 (9.1)	18 (5.5)	18 (5.5)	18 (5.5)

Table 5-2.

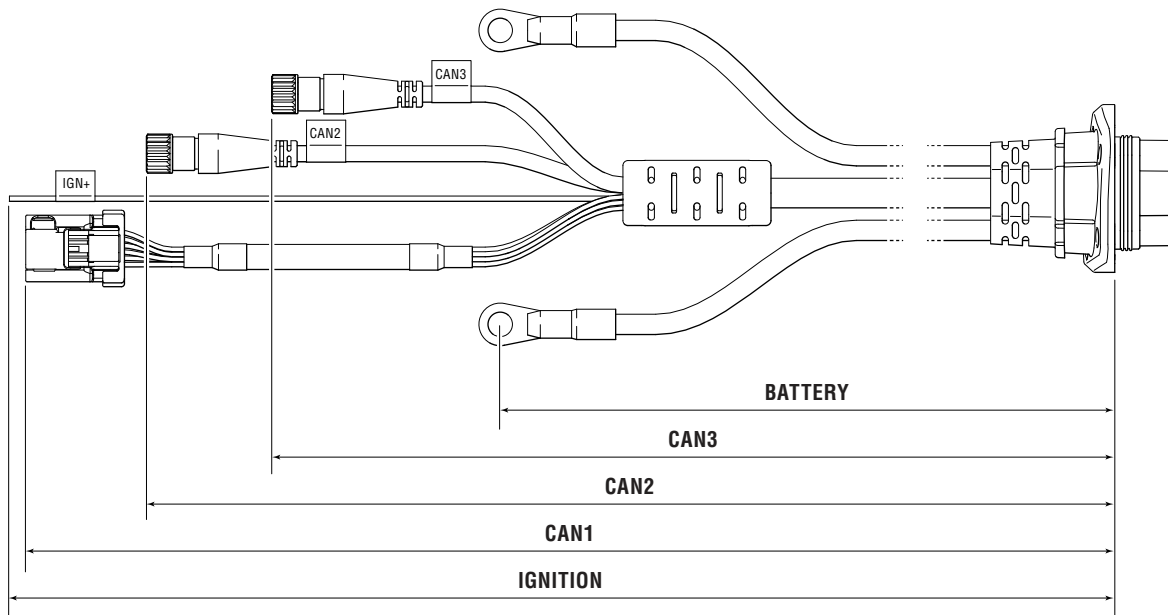

Figure 5-7. Nominal harness lengths.

### 5.3.2 Bulkhead installation

The Electric Actuator harness is supplied with a bulkhead plate and cord grip pre-installed. The harness ships with a protective cover on the connector at the actuator end.



#### NOTICE!

Leave the protective cover on the harness connector until you are ready to connect it to the actuator, otherwise the connector may be damaged.

1. Determine where you want the harness to enter the transom. Pre-drill a 1.5" hole through the transom, above the waterline, for each actuator. A template is provided in Appendix A.



#### CAUTION!

Do not install the bulkhead plate below the waterline. The fitting is not completely watertight.



2. Loosen the cord grip nut so that it can slide over the harness. Feed the harness through the hole in the transom until the bulkhead plate contacts it. Fasten the bulkhead plate to the transom using three screws (not supplied).
3. Adjust the amount of harness pulled through the bulkhead until there is enough slack for the actuator to move through its full stroke, as well as trim and tilt, without restriction or interference. Ensure the harness bend radius is not less than 3.5" (90mm) at any point in the actuator's steering range, or in the trim/tilt range. You should end up with a nice loop from bulkhead fitting to the actuator as shown in figure 5-8.
4. Tighten the strain relief gland by hand, just tight enough to compress the grommet slightly and secure the harness. Excessive torque may cause damage to the harness.

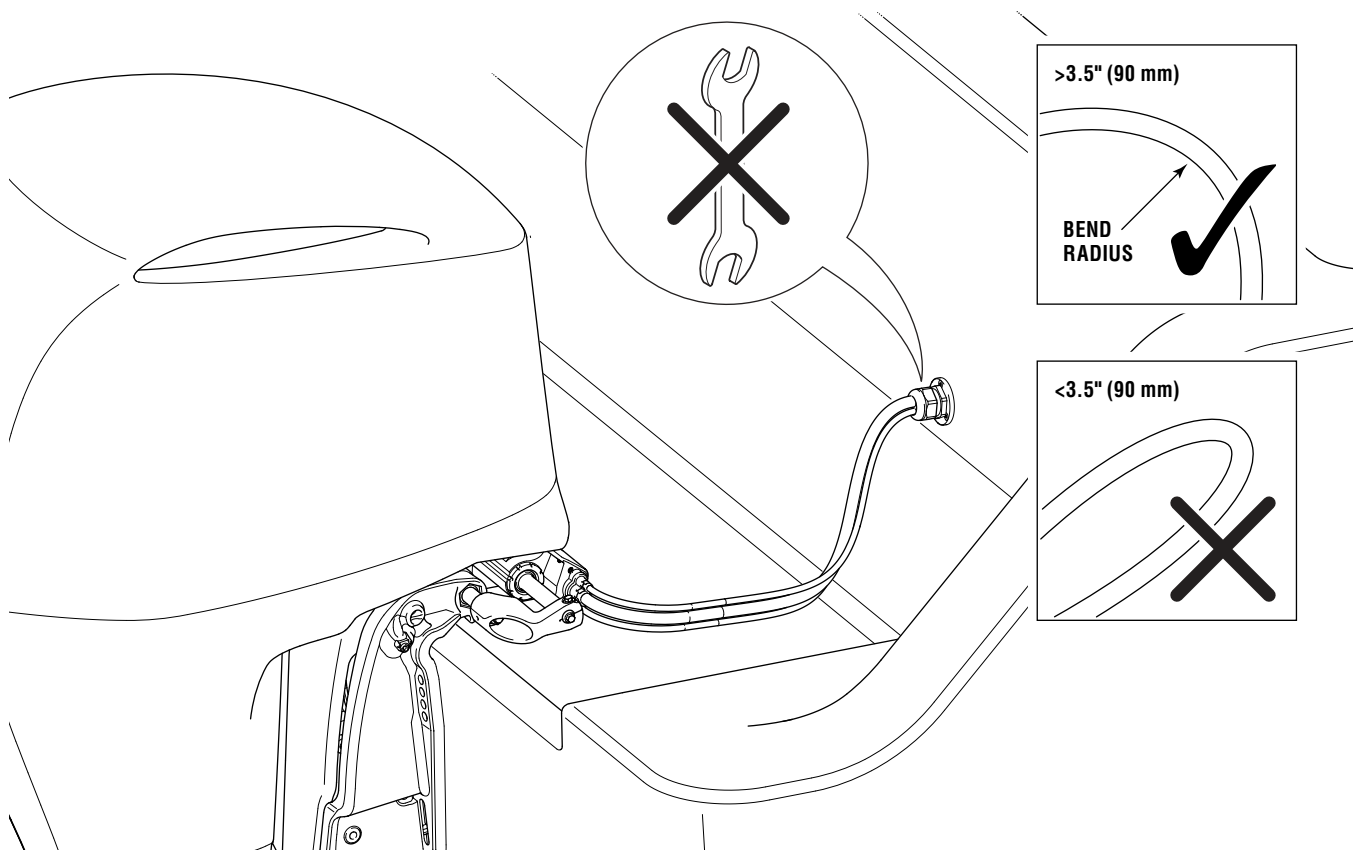

Figure 5-8. Gradual loop.

### 5.3.3 Harness protection

The actuator harness consists of three cables terminated at a single molded connector at the actuator end. For a tidy and reliable installation, the three cables must be properly bundled together in the splashwell. There are two methods you can use:

1. Use tie wraps to secure the cables together every 6" (150 mm) along the harness from the actuator to the bulkhead fitting.

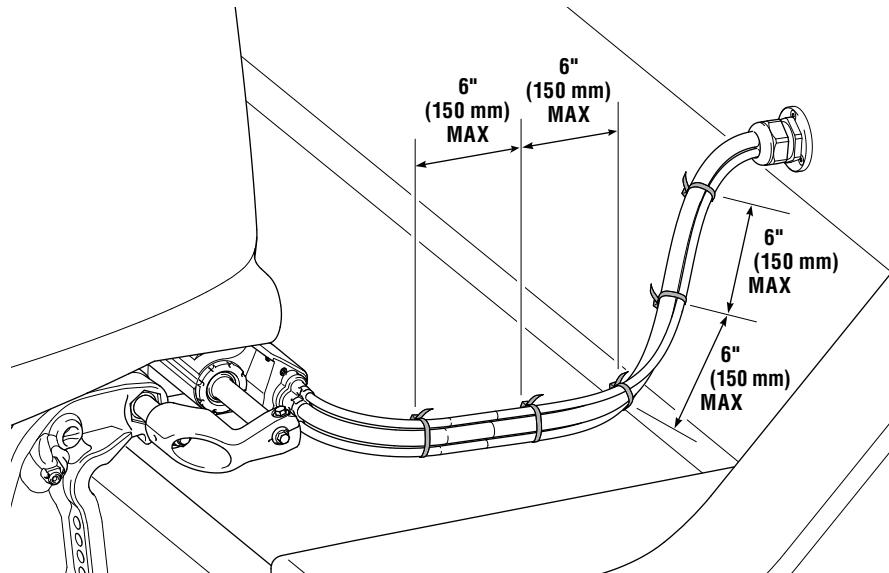

Figure 5-9.

2. For a cleaner looking installation, you can use a braided plastic cable sleeve (Techflex or similar). The harness connector has a molded feature for securing the sleeve with a tie wrap. At the bulkhead fitting you can either route the sleeve through the fitting or use a tie wrap to secure it.

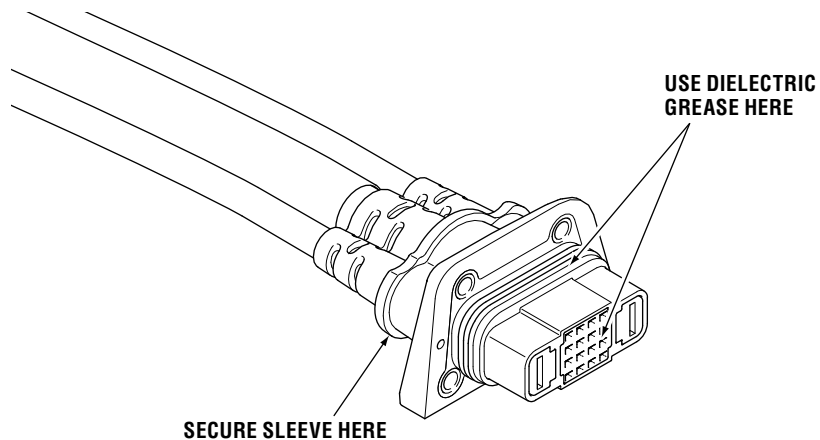

Figure 5-10.

---

### 5.3.4 Harness connection to actuator

1. Remove the shipping caps from the harness connector and the Electric Actuator.
2. Apply a light coat of the supplied dielectric grease to the connector seal and the pin slots at the end of the harness. See figure 5-10.
3. Plug the connector into the actuator. The connector is keyed so that it can only be inserted one way.
4. Tighten all four screws until they are just snug, then torque to 18–22 in-lb (2.0–2.5 Nm).

---

## 5.4 Electronic helm

There are four helm styles available. Different helms may be used at different stations. Mounting templates are in Appendix A.



#### NOTE

The EPS helm contains an electromagnet which may affect a magnetic compass. For less than one degree of effect, the helm and compass must be at least 24" (61cm) apart.



EPS Front Mount Helm  
Part No. EH1512



EPS Sport Plus Tilt Helm  
Part No. EH1532



EPS Classic Tilt Helm  
Part No. EH1552

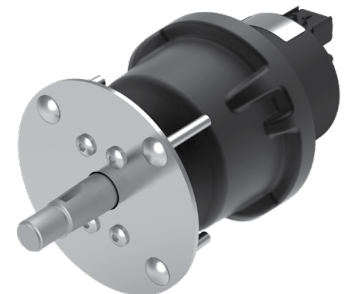

EPS Rear Mount Helm  
Part No. EH1572

---

Figure 5-11.

---

## 5.4.1 Planning

Before mounting the helm, you must be certain that you can route and connect the CAN1 harnesses in such a way that they remain within the maximum length and meet all requirements for system integrity. Review section 5.5.2 before you proceed. It lists the relevant harness and connection requirements.

---

## 5.4.2 Helm installation

Find the installation diagram for your helm in the following pages.

Before beginning the installation, carefully unpack the helm from the box and check that you have all the required hardware shown in the diagram.



### NOTE

A mounting template for each helm type can be found in Appendix A. Make sure you are using the correct template before drilling or cutting the dash.

The helm must be grounded to the negative bus or battery negative with the supplied ground strap, as described below each installation diagram. The steering sensor may be damaged by static electricity discharge if the ground strap is not installed.

We recommend that you note the type and serial number of each helm in the table below. In a multi-station system, the serial number will be required during the system setup. The helm type may be useful to the owner in the future.

Station	Helm Type	Serial No.
<b>Main</b>	<input type="checkbox"/> Front Mount <input type="checkbox"/> Sport Plus Tilt <input type="checkbox"/> Classic Tilt <input type="checkbox"/> Rear Mount	
<b>Second</b>	<input type="checkbox"/> Front Mount <input type="checkbox"/> Sport Plus Tilt <input type="checkbox"/> Classic Tilt <input type="checkbox"/> Rear Mount	

Table 5-3.

### 5.4.2.1 Front Mount helm (EH1512)

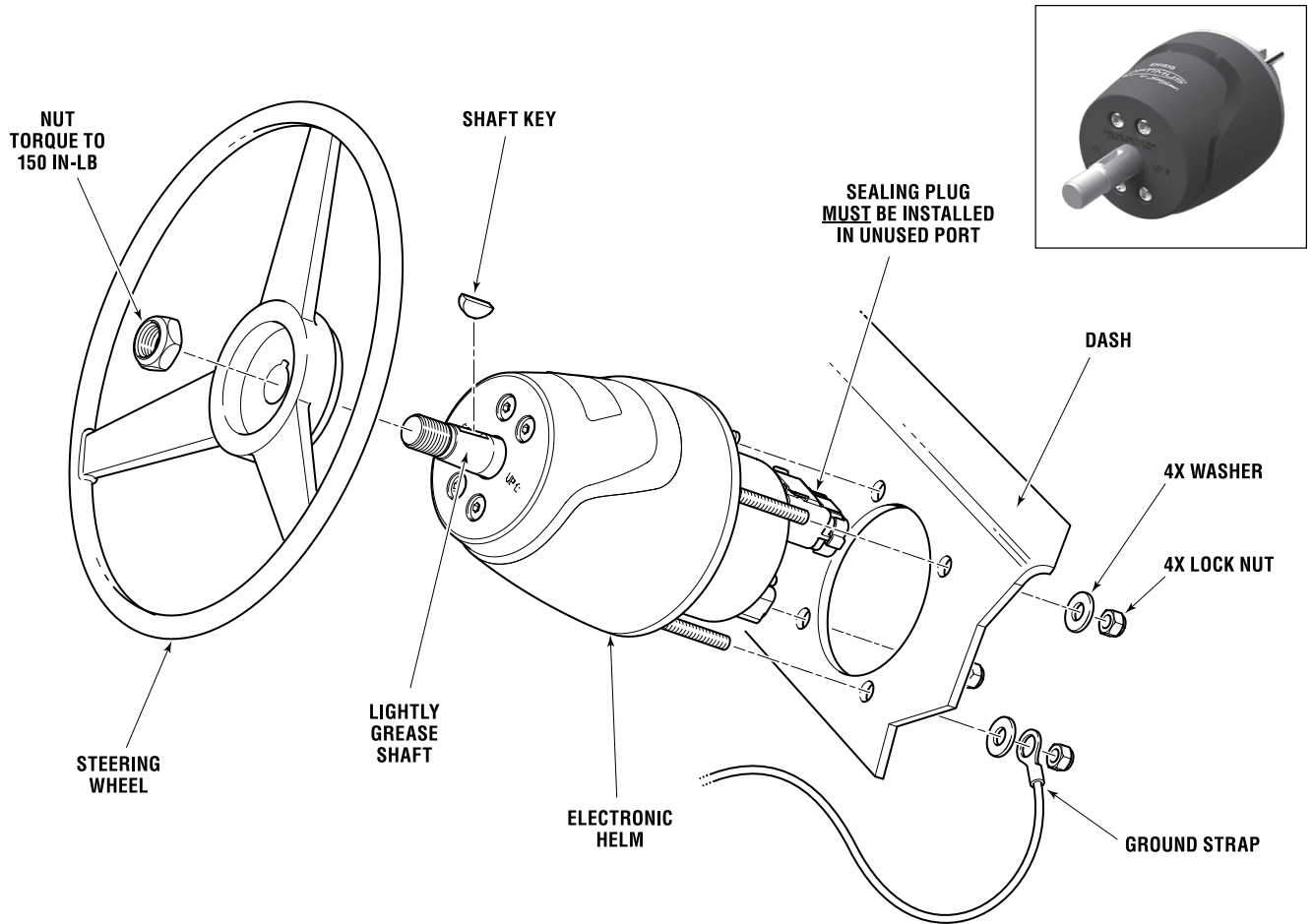

Figure 5-12.

**Ground strap:** install one end of the ground strap between the nut and washer on the helm's mounting stud as shown. Connect the other end to a ground point on the boat. This could be a negative bus bar, the negative terminal of the battery, or a designated grounding terminal.



#### **WARNING!**

Use only the self-locking nuts provided. Substitution with non-locking nuts may result in loosening or separation of equipment. This may result in loss of steering, which could lead to a collision and/or ejection from the boat, causing property damage, personal injury, and/or death.

### 5.4.2.2 Sport Plus Tilt helm (EH1532)

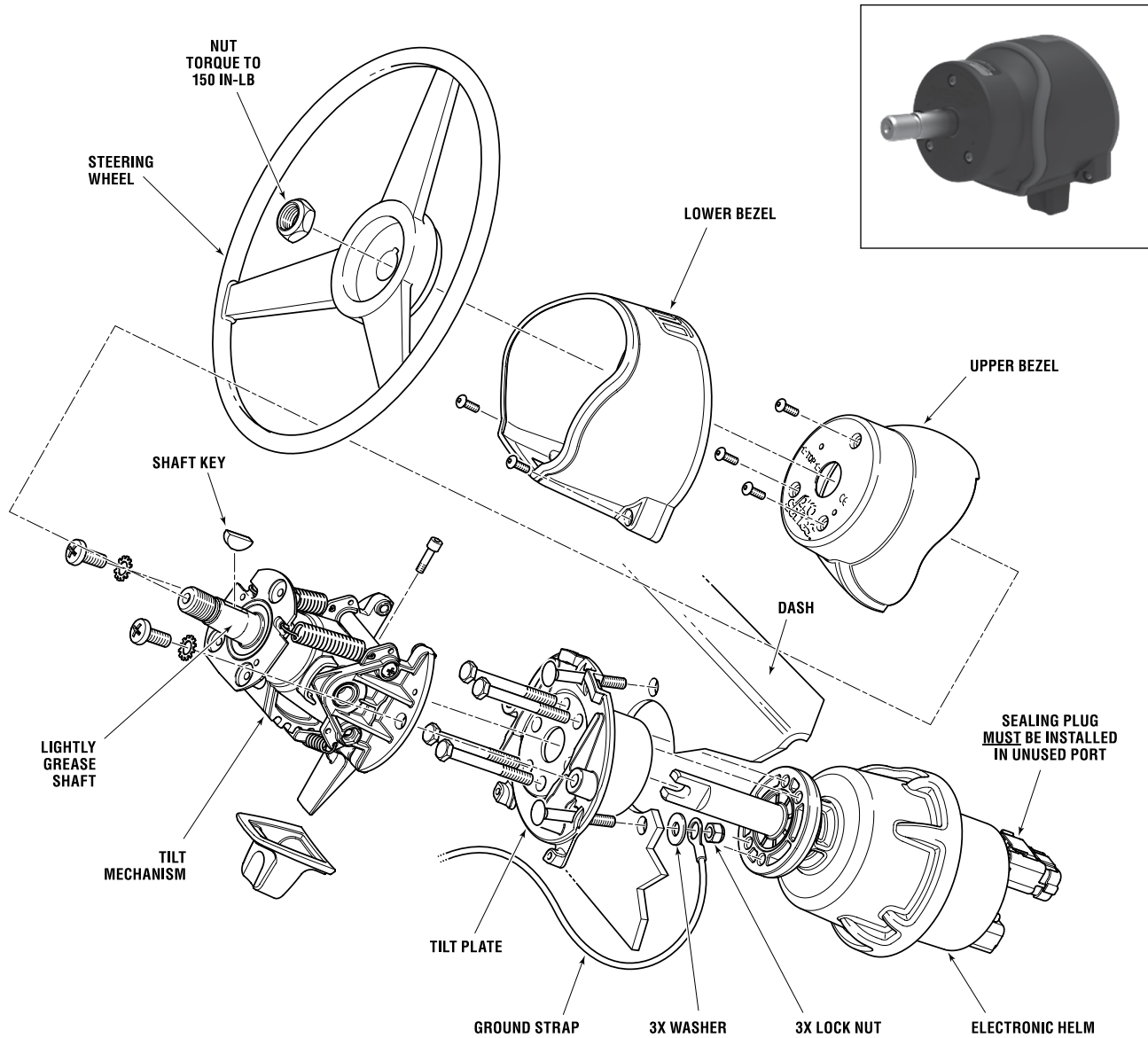

Figure 5-13.

**Ground strap:** install one end of the ground strap between the nut and washer on the helm's mounting stud as shown. Connect the other end to a ground point on the boat. This could be a negative bus bar, the negative terminal of the battery, or a designated grounding terminal.



#### **WARNING!**

Use only the self-locking nuts provided. Substitution with non-locking nuts may result in loosening or separation of equipment. This may result in loss of steering, which could lead to a collision and/or ejection from the boat, causing property damage, personal injury, and/or death.

### 5.4.2.3 Classic Tilt helm (EH1552)

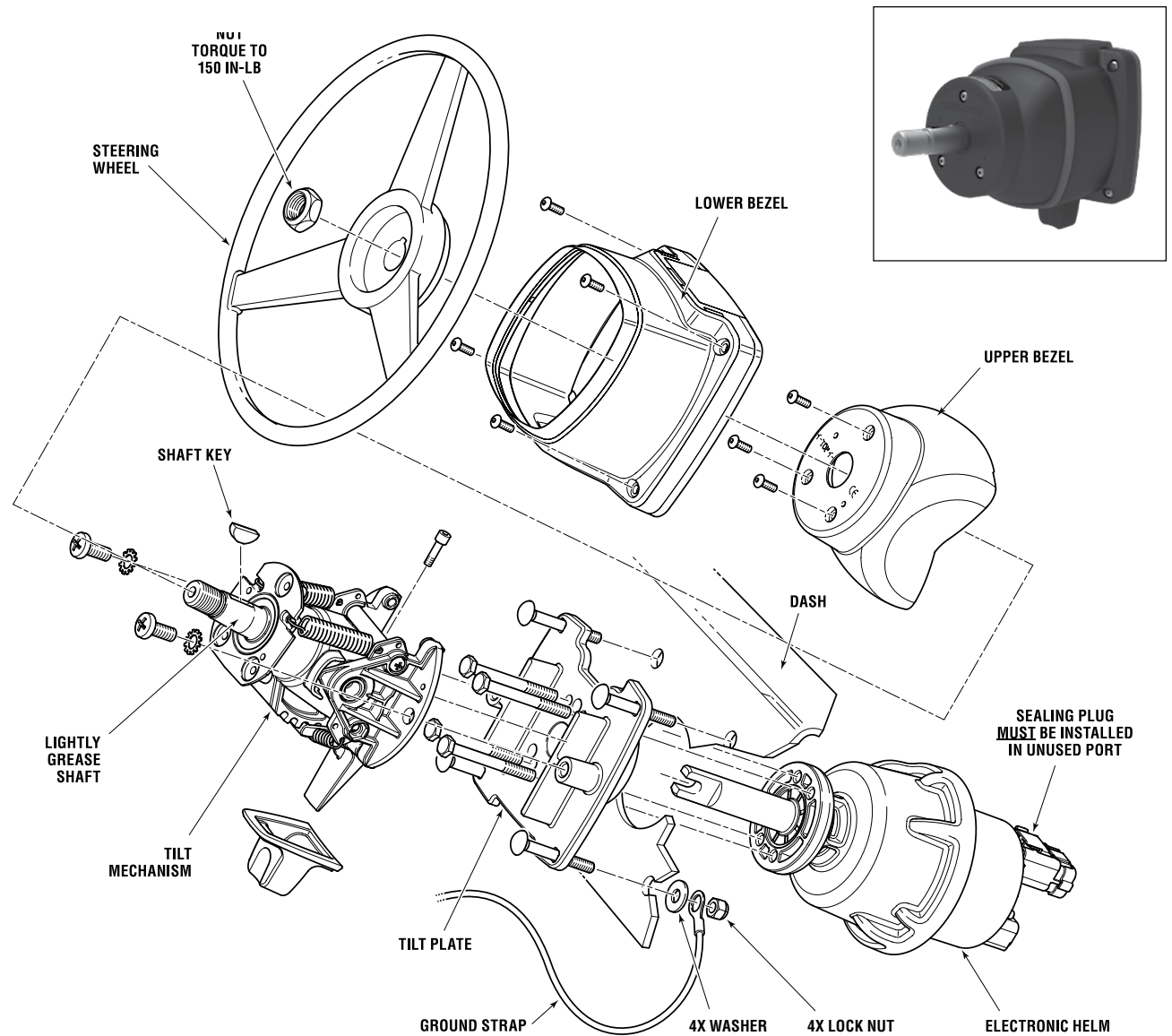

Figure 5-14.

**Ground strap:** install one end of the ground strap between the nut and washer on the helm's mounting stud as shown. Connect the other end to a ground point on the boat. This could be a negative bus bar, the negative terminal of the battery, or a designated grounding terminal.



#### **WARNING!**

Use only the self-locking nuts provided. Substitution with non-locking nuts may result in loosening or separation of equipment. This may result in loss of steering, which could lead to a collision and/or ejection from the boat, causing property damage, personal injury, and/or death.

#### 5.4.2.4 Rear Mount helm (EH1572)

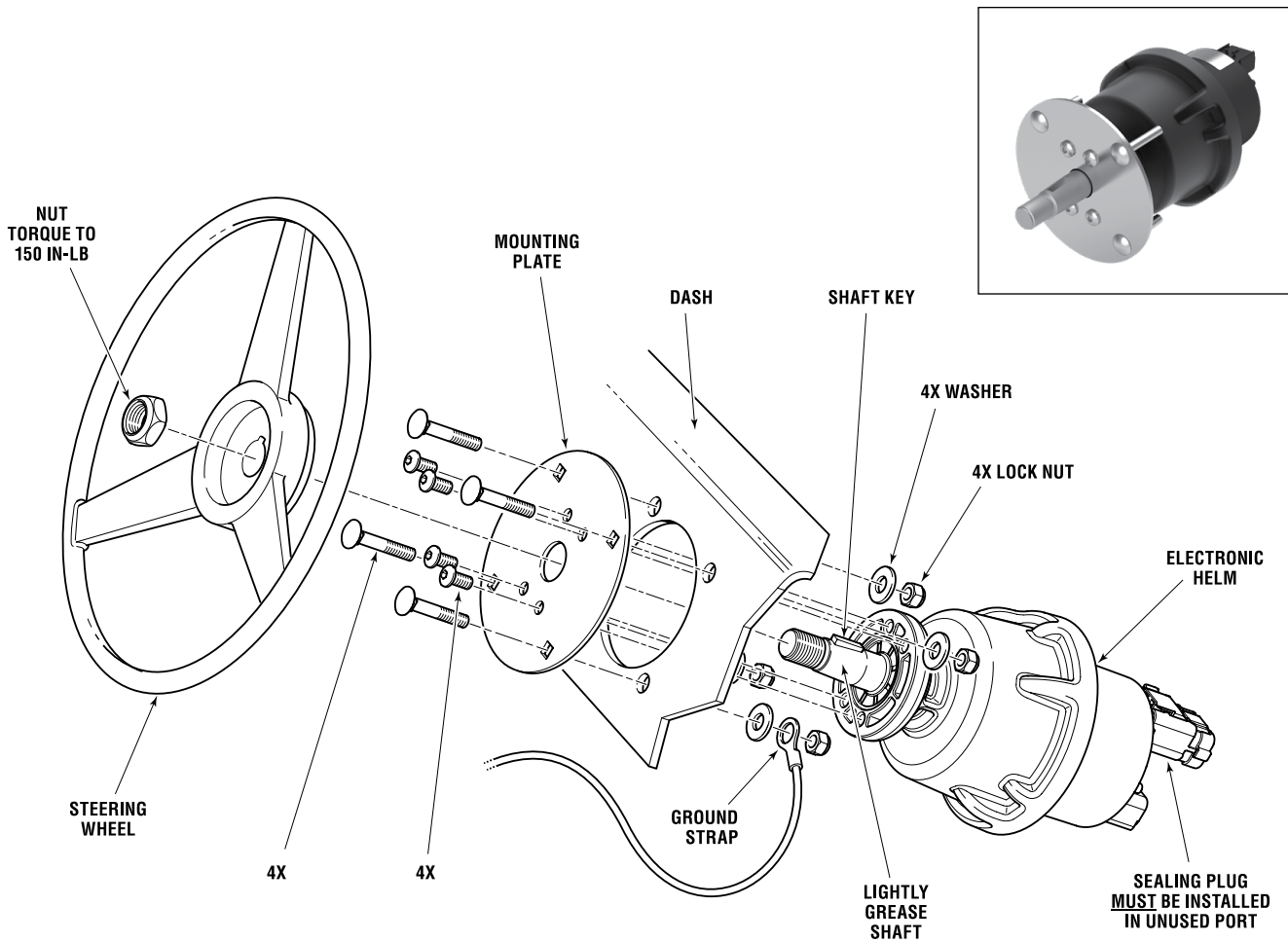

Figure 5-15.

**Ground strap:** install one end of the ground strap between the nut and washer on the helm's mounting stud as shown. Connect the other end to a ground point on the boat. This could be a negative bus bar, the negative terminal of the battery, or a designated grounding terminal.



#### **WARNING!**

Use only the self-locking nuts provided. Substitution with non-locking nuts may result in loosening or separation of equipment. This may result in loss of steering, which could lead to a collision and/or ejection from the boat, causing property damage, personal injury, and/or death.



## 5.5 CANtrak display

### 5.5.1 Planning

There are two color CANtrak displays available, as shown in table 5-4. All displays are identical and can be used at any station.

Display Part No.	For use with	Notes
ED1700	Twin, triple, and quad outboard vessels	Comes with harness CM21504 for connection to both CAN1 and CAN2 networks
ED1800	Single outboard vessels	Comes with harness CM20030 for connection to CAN1 only

Table 5-4.

### 5.5.2 Installation

Mount the display where it easily visible from the helm station. Consider the following:

- Mount the display vertically, or within 60 degrees of vertical. Do not mount it parallel to the deck unless the helm station is in an enclosed wheelhouse where no water can accumulate on the face of the display.
- Ensure adequate ventilation around the unit.
- Ensure you can get to the rear of the unit for harness connections.



#### NOTE

- A CANtrak display is required at the main helm station but is optional at secondary control stations.
- A buzzer kit (HA5493) is required at any control station without a display.
- A mounting template is in Appendix A.

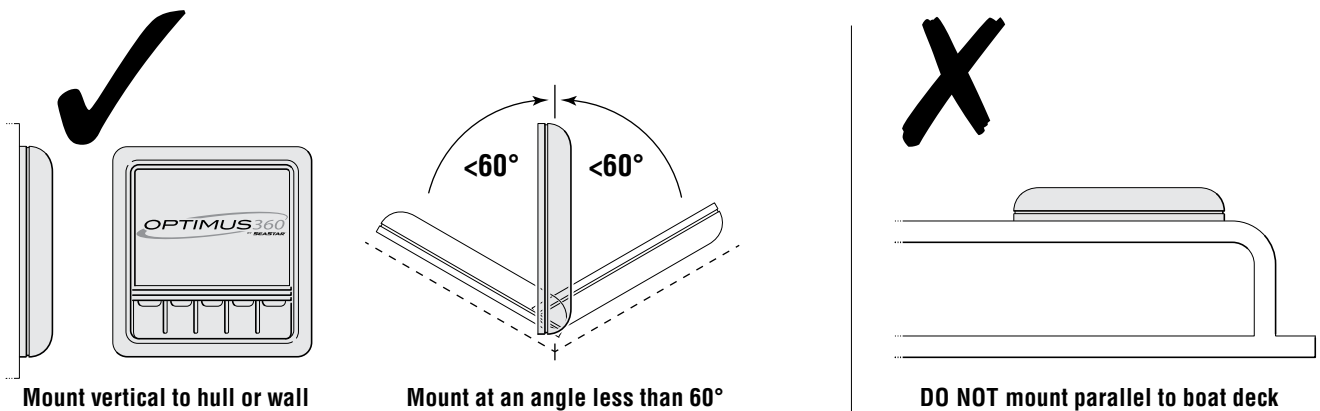

Figure 5-16.

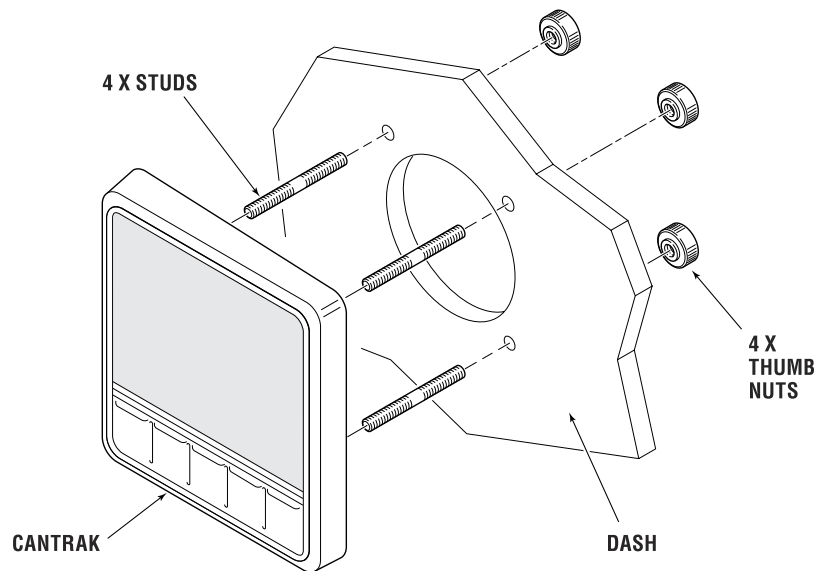

Figure 5-17.

## 5.6 Electrical connections

All system connections are made from the Electric Actuator harness bundle, which has the following connections:

1. 12V power
  - a. +ve (red)
  - b. -ve (black)
2. Communication bundle
  - a. CAN1
  - b. CAN2 (optional on single-engine systems)
  - c. CAN3 (for engine RPM)
  - d. Ignition sensing (purple)

### 5.6.1 Power connection



#### NOTE

- All system wiring and power connections must be made to ABYC standards.
- The negative terminals of all batteries must be connected together.
- Refer to *ABYC E-11 – AC and DC Electrical Systems on Boats*

#### 5.6.1.1 Planning your 12V power connections

Figure 5-18 shows a sample power schematic. For each actuator in your system, you will need the following items (not included with your installation kit):

- A 12V DC power source capable of supplying 40A peak current during aggressive use.



### NOTE: Typical Source Connections

- Direct to the batteries.
- To battery switches. (Never switch the negative wire.)
- To a bus bar or power distribution panel. Ensure the wire size from the bus to the batteries is sufficient to handle the peak current of all devices connected to the bus.

- A 60A circuit breaker, designed for marine use.
- Red wire that meets ABYC requirements, of the appropriate size for the intervening wire length between the actuator harness and the battery (see figure 5-18 and table 5-5).
- Crimp lugs sized for connecting the circuit breaker to the power source.
- Secondary circuit protection devices if required (see note).



### NOTE: Circuit Protection

- ABYC standards require a circuit protection device within 7" (180mm) of the power source on all wires carrying positive voltage.
- If the circuit breaker is more than 7" (180mm) from the source, a secondary device (circuit breaker or fuse) must be located within 7" of the battery to protect the intervening wire.
- Secondary device must be rated based on intervening wire size, and usually has a higher rating than the circuit breaker.
- Refer to *ABYC E-11 – AC and DC Electrical Systems on Boats* for more details.

L <sub>w</sub> , m (ft)	AWG (mm <sup>2</sup> )
< 1.0 (3.3)	6.0 (13.5)
< 3.0 (9.8)	4.0 (21.0)
< 4.5 (14.7)	2.0 (34.0)

Table 5-5

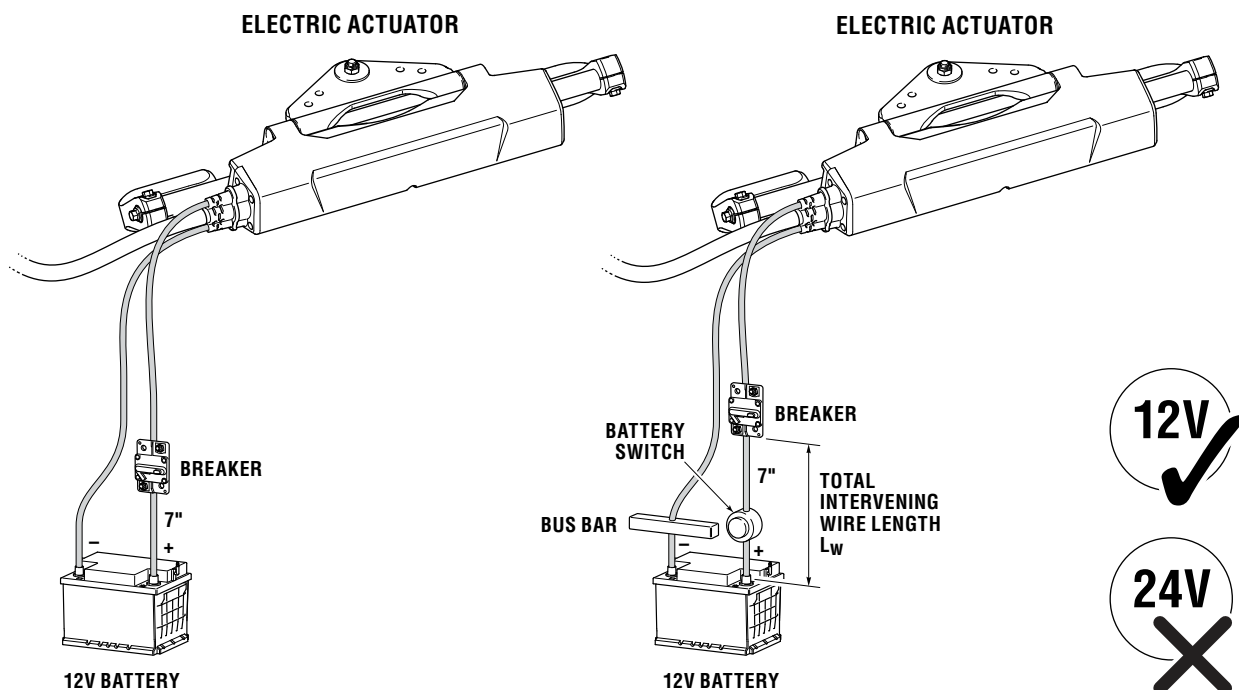

Figure 5-18.

### 5.6.1.2 Special considerations for multi-engine applications

To prevent the Electric Actuator from draining batteries while trolling on a single motor, you must connect the batteries in such a way that the actuator is always connected to a battery being charged.

Figure 5-19 shows a possible triple-engine connection using battery switches with a combine function and an automatic charging relay (ACR). In this example, if you are trolling on the center engine the ACR will detect that the starboard battery is being discharged and connect it to the center battery. A twin-engine system would look similar to the center-starboard pair in the figure, with center engine replaced with port engine.

Figure 5-20 shows a possible quad-engine connection, but without ACRs. In single-engine trolling this configuration does not guarantee that the actuator is connected to a charging battery, so the battery switch must be set to 'Both' (or '1+2' or 'All' on some switches). If the engines are always trolled in pairs (inboard pair or outboard pair) the position of the switches is not important because one charging battery will always be connected to the actuator.



#### NOTE

To make your system as error-proof as possible, Dometic recommends the use of automatic charging relays in multi-engine applications.

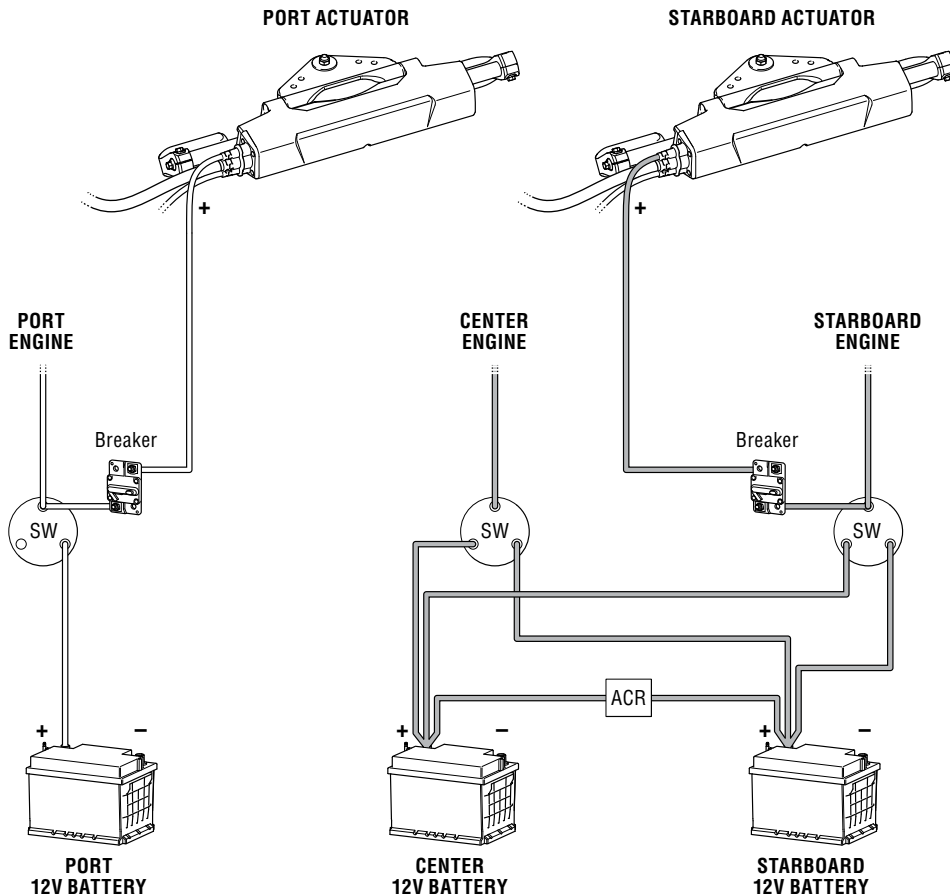

Figure 5-19.

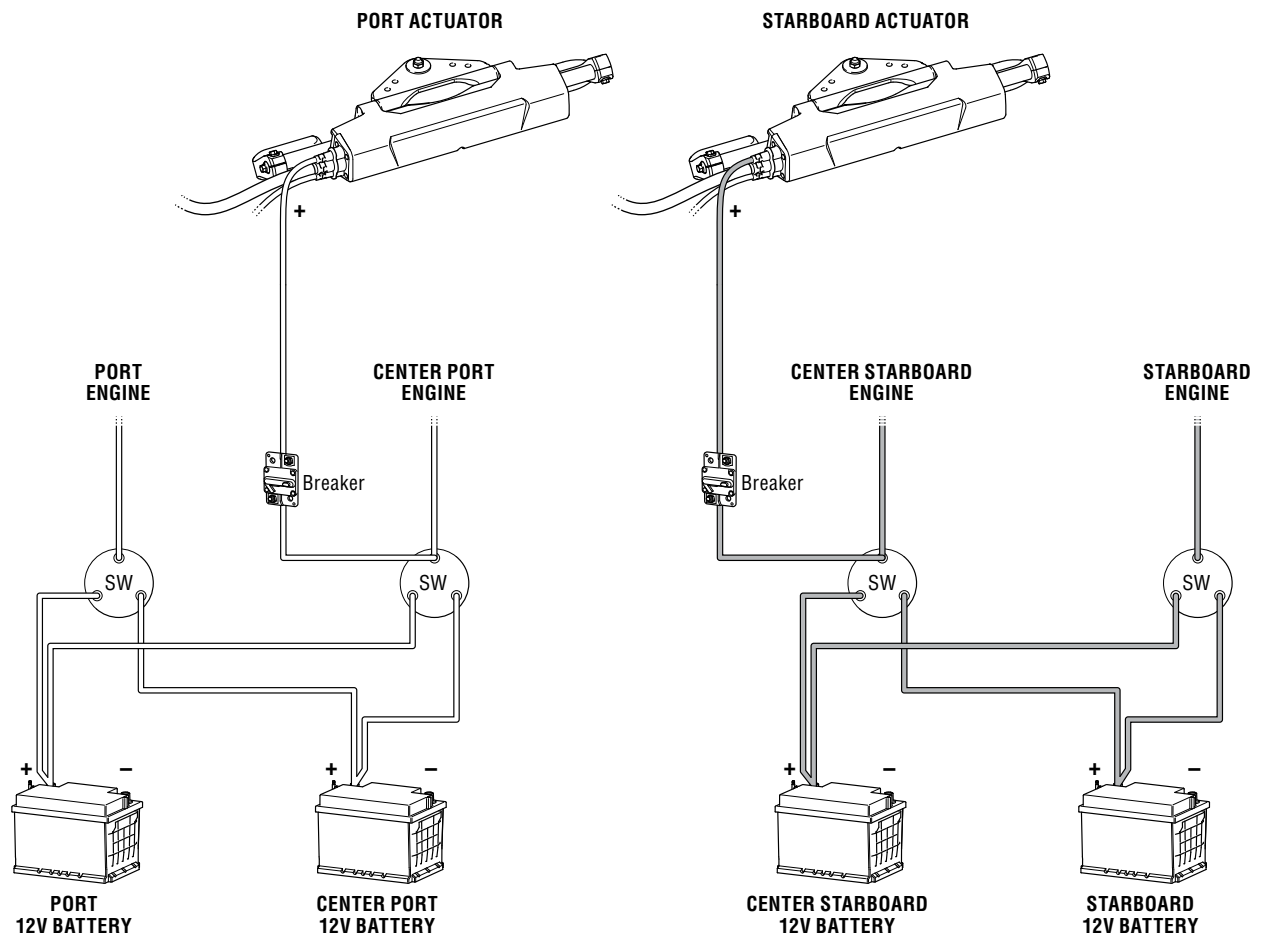

Figure 5-20.

### 5.6.1.2 Making your 12V power connections

1. Install the 60A circuit breakers within 7" (180mm) of the power source for each actuator. Use corrosion resistant, stainless steel hardware.
2. Connect the positive power source to the corresponding circuit breaker. Size the wire for at least 60A. Tighten the terminal to the torque specified by the circuit breaker manufacturer.



#### CAUTION!

Lugs must be crimped and soldered on all power connections.

3. Connect the -ve (black) lead from each actuator directly to the battery negative terminal or a negative bus bar. Do not use the vessel bonding system for the negative connection.
4. Connect the +ve (red) lead from each actuator to the corresponding circuit breaker. Tighten the terminal to the torque specified by the circuit breaker manufacturer.



#### NOTICE!

The power supply wires in the harness are correctly sized for the load and harness length. Do not extend the harness. Excessive voltage drop will result in reduced performance and may damage electrical equipment.

## 5.6.2 CAN1 connection

CAN1 is a fault-tolerant network used to connect the actuator to the helms and CANtrak displays. The network is safety-critical, so be sure you understand and follow all the requirements in this section.



### CAUTION!

CAN1 is a private network that is not NMEA 2000 compatible.

- Do not attempt to connect any other devices to this network.
- Do not cut, splice, or otherwise modify any harnesses.

### 5.6.2.1 Planning

On small boats the CAN1 harness may be long enough to reach the helm, but in many applications it will not, so it will need to be extended. Table 5-6 shows the harnesses that are available, up to 36ft (11m) long, with an available 36ft (11m) extension harness.

<b>CAN1 HARNESS – HELM TO SCU</b>		
One harness is required for single helm station, two are required for multiple helm stations.		
<b>DESCRIPTION</b>	<b>LENGTH, FT (m)</b>	<b>PART No.</b>
Harness, EPS, H4, 6 PIN FCI , F-F	6 (1.8)	CM20406
	12 (3.6)	CM20412
	18 (5.5)	CM20418
	24 (7.3)	CM20424
	30 (9.1)	CM20430
	36 (11.0)	CM20436
Harness, EPS, FTCAN Extension, M-F	36 (11.0)	CM22036
Harness, Wye , M-F-F	2 (0.6)	CM21702
Harness, gender changer, M-M	1 (0.3)	CM22401
CAN1 Hub, 4xM	N/A	HA5497

Table 5-6.

### Considerations

- The CAN1 connector on the actuator harness is female. In order to use the CM204XX harnesses you must connect a 1ft gender changing harness (CM22401) to the actuator harness first. Alternatively, you may use an extension harness (CM22036) to connect the actuator harness directly to a helm, but it is only available in one length.
- Until the CAN1 hub (HA5497) is available, most systems will require one or two wye harnesses (CM21702) to make the connections.
- Do not use more than two extensions (for a total of three harnesses) between consecutive devices.
- The harness length to the farthest device may not exceed 120ft (36m) in total.

The pages that follow present some sample connection diagrams to help you determine the harnesses that you need. It's not possible to show every possible configuration, so please contact Dometic technical support if you need assistance.

**CAUTION!**

Do not exceed the maximum harness length or use more than two extensions. Doing so may cause excessive voltage drop in the CAN bus and lead to communication failures.

**NOTE**

- Every harness connection is a potential failure point. Minimize the number of connections in your system and locate them in dry areas protected from incidental physical damage.
- Never put connections in inaccessible places like rigging tubes or conduit.

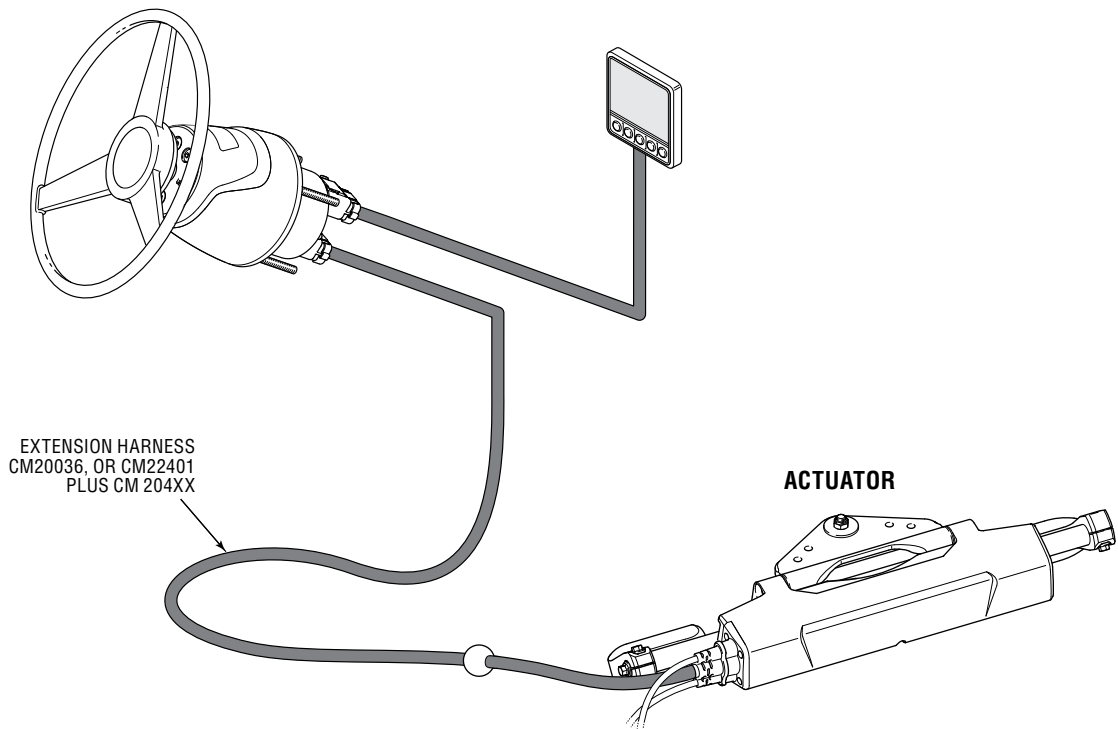

Figure 5-21. Single Engine, Single Station.

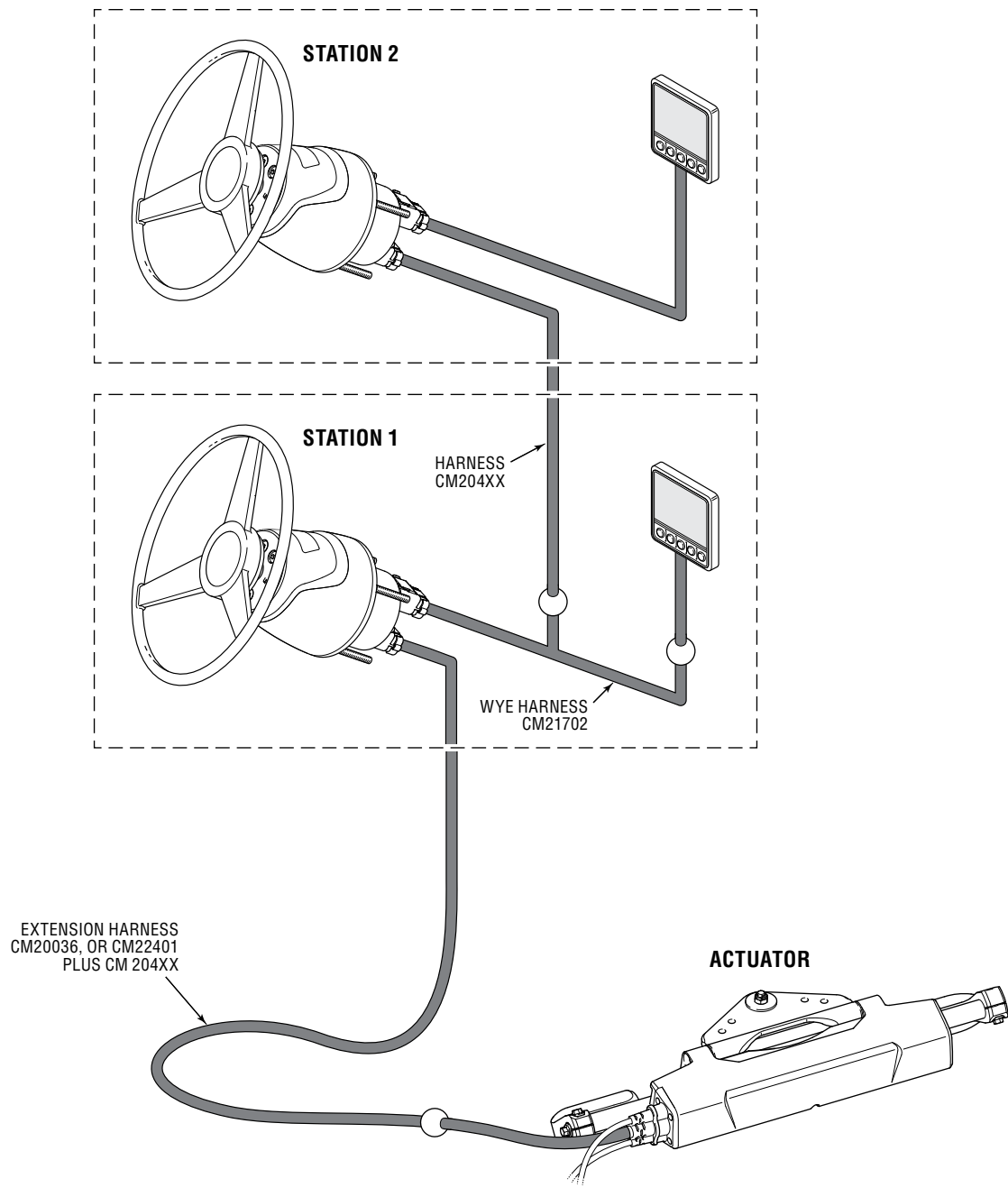

Figure 5-22. Single Engine, Dual Station.



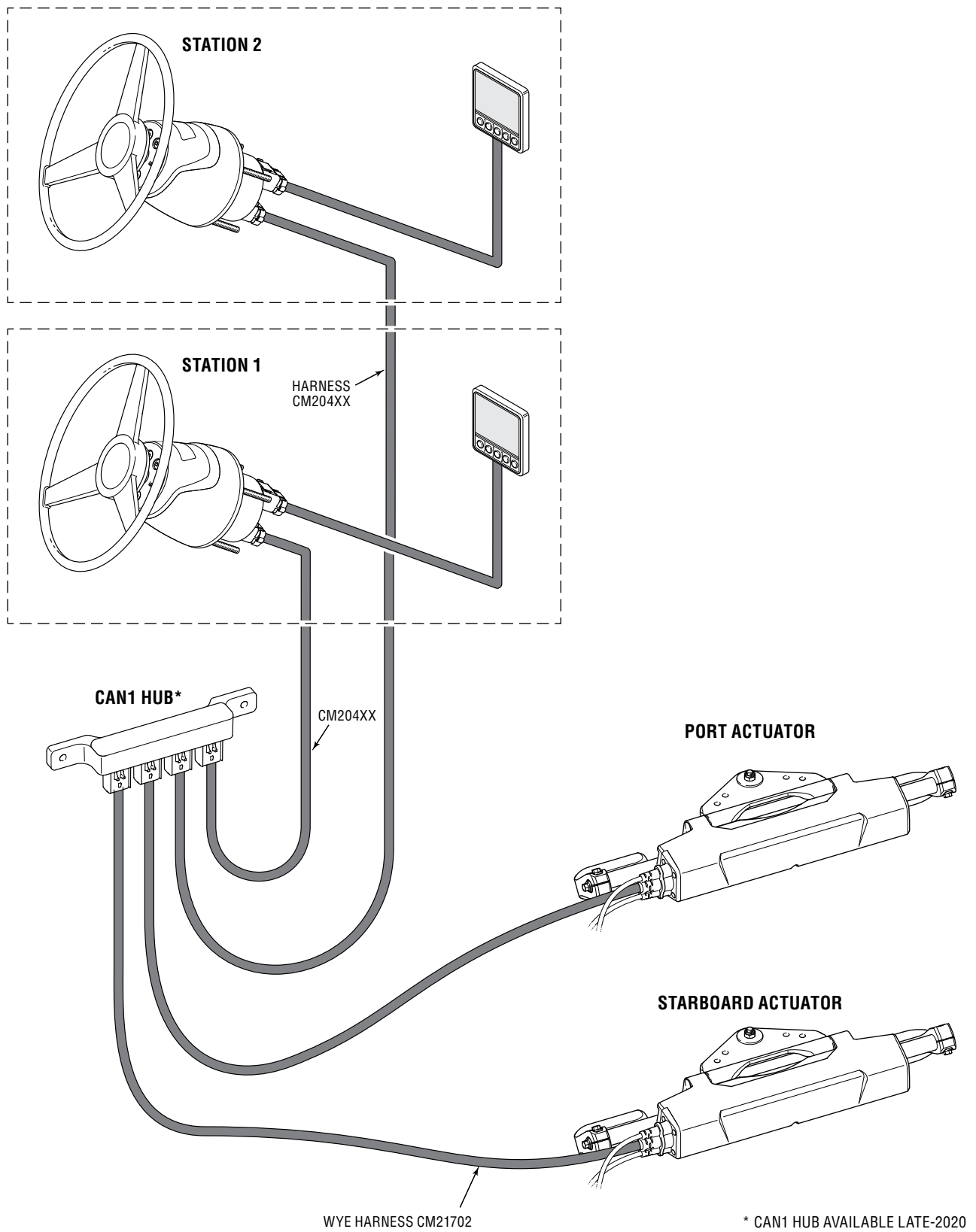

Figure 5-23. Multi-Engine, Dual Station, Option 1. Hub available late-2020.

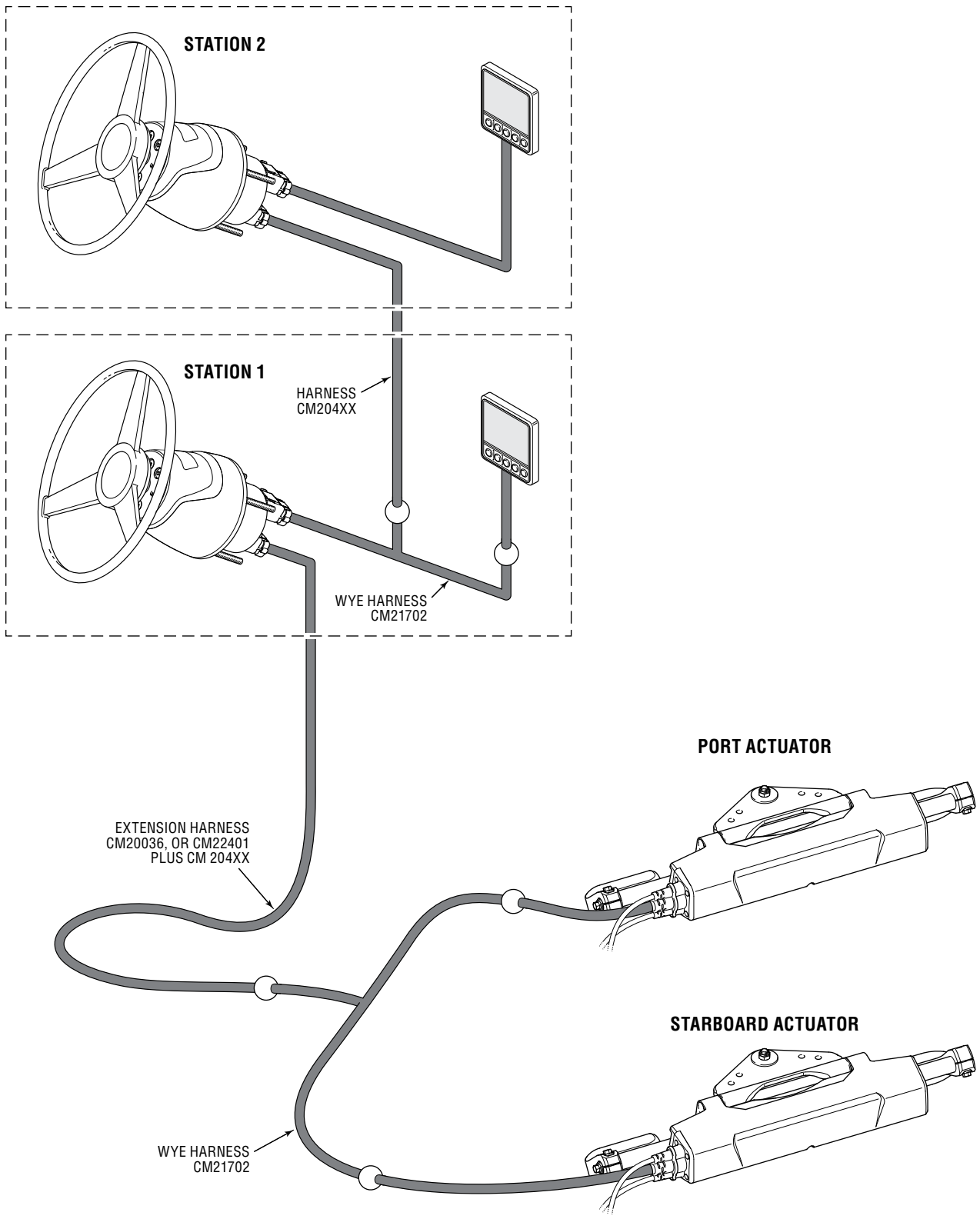

Figure 5-24. Multi-Engine, Dual Station, Option 2.

## 5.6.2.2 Installation

### Harness routing

It is important to route all CAN1 harnesses in a way that protects them from standing water, physical damage, from being stepped on, or from being pulled. Best practice is to run the harness through PVC conduit. Use tie wraps or other means to secure harnesses at all connection points, at entry and exit from rigging conduit, and at regular intervals along its length if you do not have rigging conduit.



#### CAUTION!

Failure to secure the harness may result in harness damage, leading to loss of communication. This may result in loss of steering, which could lead to a collision and/or ejection from the boat, causing property damage, personal injury, and/or death.

### Connectors

Installation of the connectors into the receptacles is straightforward. Push the female connector into the mating male socket, listen for the click indicating a positive lock, then engage the secondary lock as shown in figure 5-25.

You must secure the harnesses at the helm using the harness tie points, as shown in figure 5-26.



#### CAUTION!

A sealing plug must be installed in any unused ports.

#### TO LOCK:

1. PRESS THE CONNECTOR FIRMLY ONTO THE RECEPTACLE
2. LISTEN FOR THE "CLICK" AS THE CONNECTOR LOCKS
3. PUSH TO ENGAGE THE SECONDARY LOCK

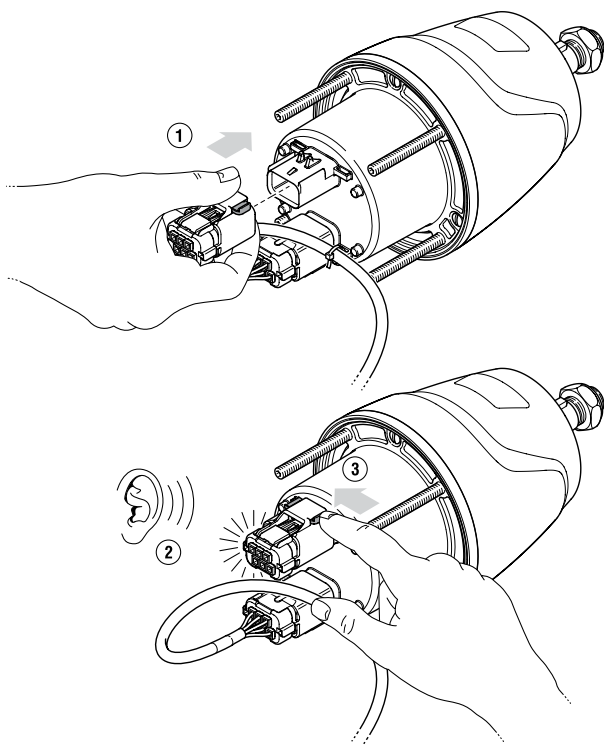

#### TO UNLOCK:

1. PUSH TO DISENGAGE THE SECONDARY LOCK
2. SQUEEZE TO UNLATCH THE CONNECTOR
3. PULL TO REMOVE

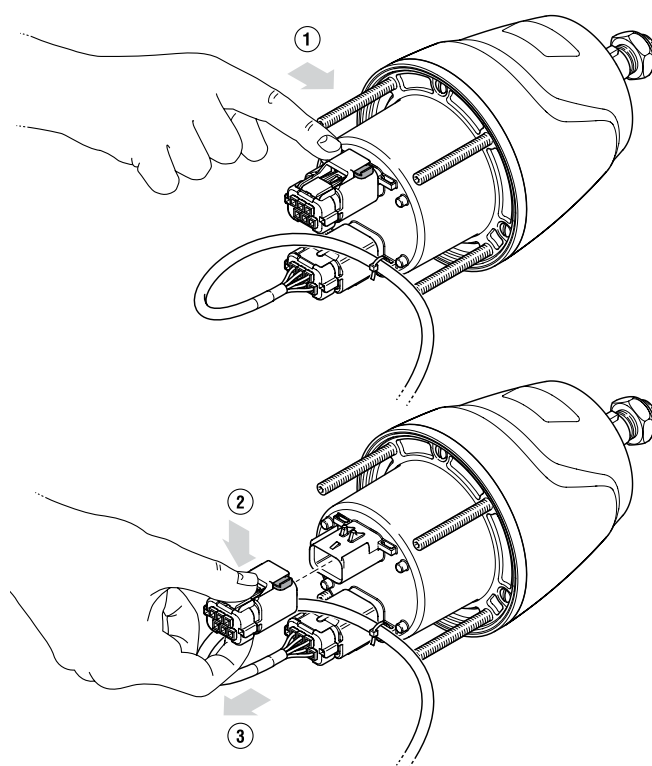

Figure 5-25.

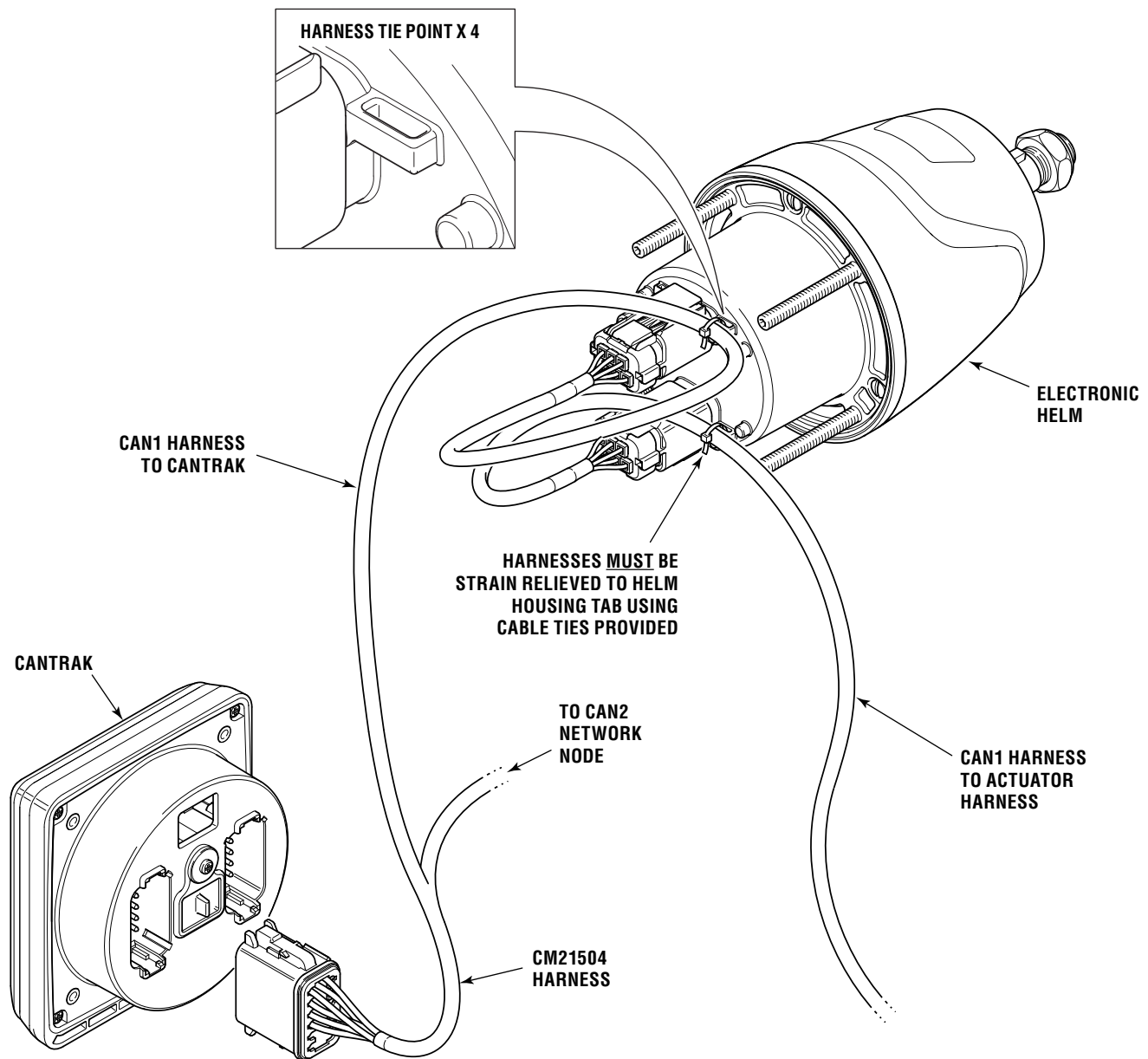

Figure 5-26.

### 5.6.3 CAN2 connection

The CAN2 network is used to connect the CANtrak display and a third-party autopilot that is certified by Dometic to work with the EPS system. The CAN2 network is optional on single-engine systems; if you are not using an autopilot, leave the cap on the harness connector, coil the harness, and secure it out of the way.



#### NOTE

The details of each autopilot's network connection will be specific to the manufacturer, so be sure you read and understand the instructions that come with the autopilot system.

### 5.6.3.1 Planning

You will need to build a small CANbus network with a node (tee connector) for each actuator, each display, and for the autopilot. Locate the nodes close to the devices and use an extension harness to create a network backbone. Your network will look similar to figure 5-27 (only one actuator is shown, but you will need to connect both in a multi-engine system). The CAN2 bus is powered by the SCU, so a separate power supply connection is not required.

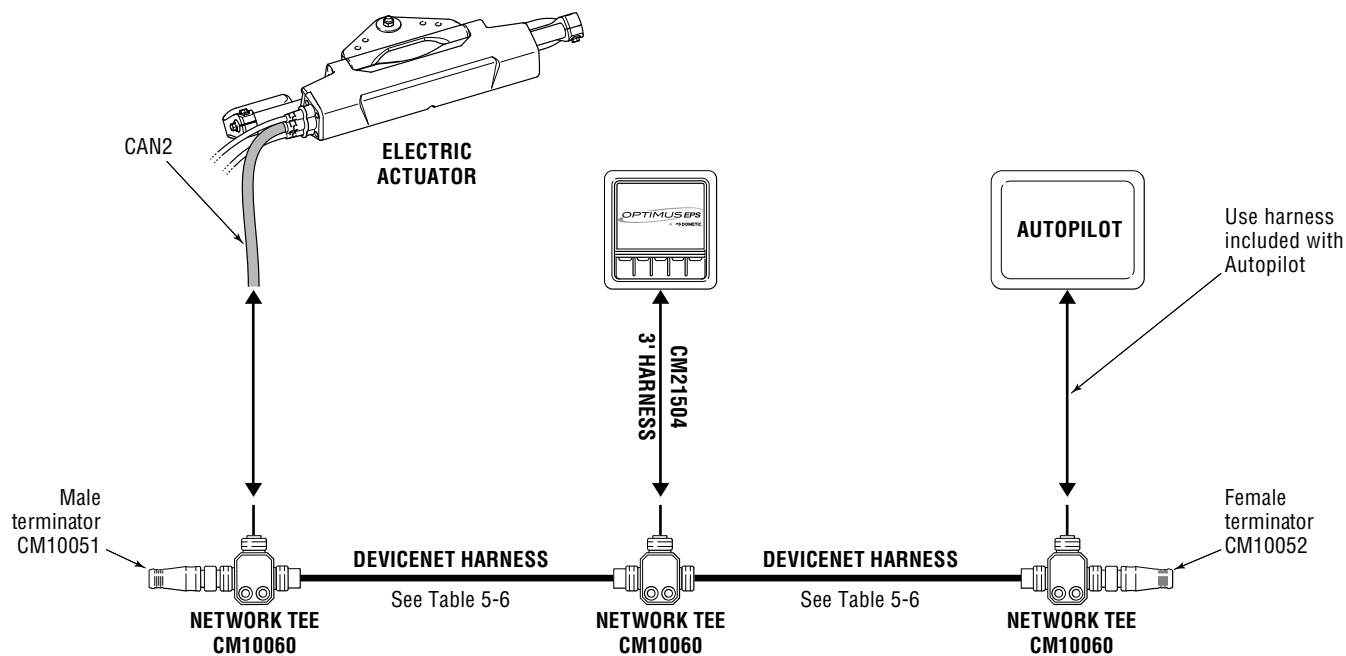

Figure 5-27.



#### NOTICE!

If you are using a Simrad SG05 autopilot you must use a power isolating tee such as a Navico 000-12259-001 or a Garmin 010-11580-00. Do not use a CM10060 for this connection or electrical damage may occur.

Optimus EPS uses DeviceNet cables with sealed M12 connectors that are NMEA 2000 compliant and compatible with the tees supplied with the autopilot systems. Table 5-7 shows the available extension harnesses you can use to build your backbone. You can chain up to three harnesses together to a maximum length of 90 feet (27.3m).



#### NOTE

- Every connection is a potential failure point. Minimize the number of connections in your system and always locate them in dry and protected areas.
- Never put connections in inaccessible places like rigging tubes or conduit.
- Do not cut or splice DeviceNet harnesses.
- Do not connect anything other than Optimus components or approved autopilots to the CAN2 network.

Micro-c DeviceNet harness		
Description	Length, ft (m)	Part No.
Micro-C Extension, Male/Female	1 (0.3)	CM10001
	3 (0.9)	CM10003
	6 (1.8)	CM10006
	9 (2.7)	CM10009
	12 (3.6)	CM10012
	16 (4.9)	CM10016
	20 (6.1)	CM10020
	30 (9.1)	CM10030

Table 5-7.

### 5.6.3.2 Installation

1. Install the network tees as shown in figure 5-28.
2. Plug the harnesses in to the tees. The connectors are keyed so that they only install in one way. Hand tighten the connections. Do not use tools. Use tie wraps or other means to secure the harnesses to prevent strain on the connection.



#### NOTE

The actuator harness has two DeviceNet connectors, labeled CAN2 and CAN3. Be sure you are connecting the one marked CAN2.

3. Ensure that you have two – and only two – terminating resistors, one at each end of the network backbone, as shown in figure 5-27.
4. When installation is complete, use a permanent marker to draw a line across all DeviceNet connections. If one of the connections become loose it will be evident.

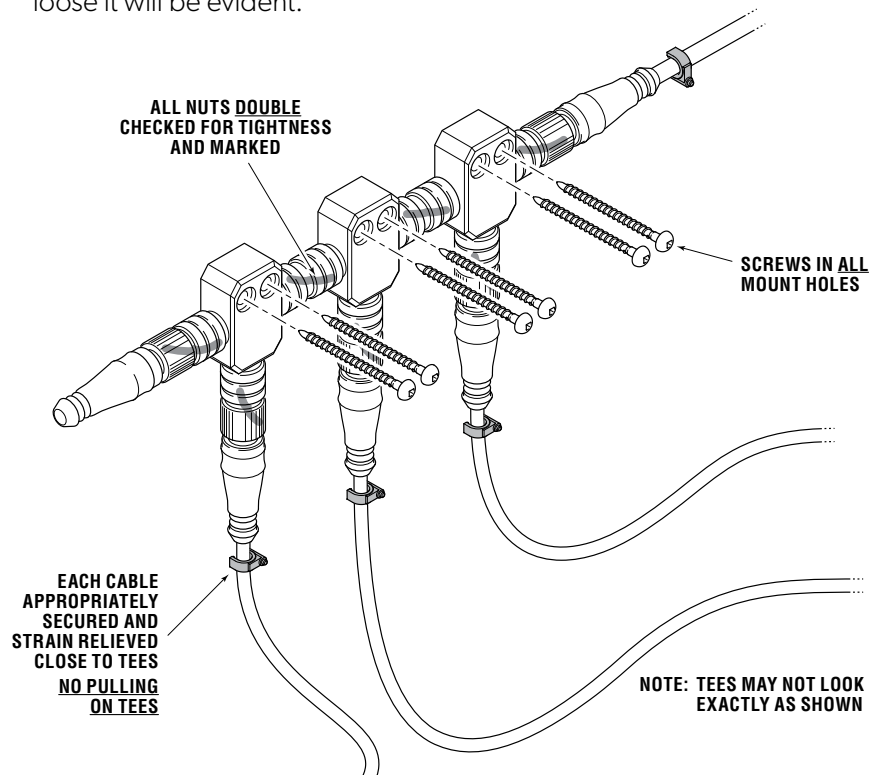

Figure 5-28.

## 5.6.4 CAN3 connection (Engine RPM)

The CAN3 connector on the SCU harness is used to get the engine RPM signal from an NMEA 2000 network. The Optimus system will also broadcast data, such as rudder position. You have two options to make this connection:

**Use existing bus:** if the boat already has a NMEA 2000 bus with an RPM signal on it, you can simply connect the CAN3 harness to an available DeviceNet tee on the bus. If no tee is available, you will need to add one (CM10060). You may also require an extension harness from Table 5-7 to extend the backbone and bring the tee within reach of the harness.

**Create a new bus:** if the boat does not have an NMEA 2000 bus, you can create one using kit HA5496. In addition to the kit you will need a gateway device that bridges the engine network to the NMEA 2000 bus, supplied by the engine manufacturer.

The instructions from section 5.6.3.2 apply to the CAN3 installation as well.

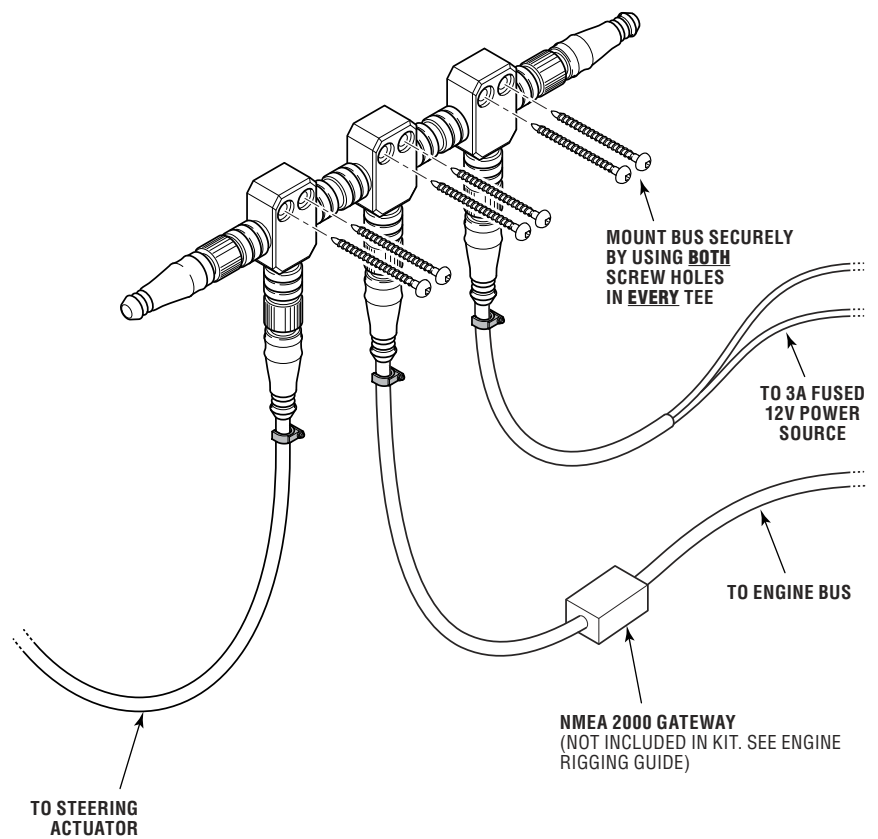

Figure 5-29.

## 5.6.5 Ignition sensing

The Electric Actuator harness has a single purple ignition-sensing wire that must be connected to an ignition source (has system voltage when ignition is on). This wire provides the wake-up signal to the Electric Actuator; the steering system will not work without it.



### **NOTE: Multi-engine applications**

The electric steering actuators also receive a wake-up signal over the CAN1 network, so both actuators will be on as long as one of the ignition-sensing wires has a signal. You must still connect both sensing wires.

### **Important wiring requirements**

- The ignition-sensing wire must be routed in such a way that it is protected from physical damage, water, and high temperatures over its entire length. Incidental splashing water is okay but avoid immersion or prolonged spray. Never put splices in a wet area.
- Use tie-wraps or other strain-relief devices on either side of any splice and at the final connection point. If someone inadvertently pulls on the wire anywhere in its travel it must not pull any splice or connection apart.
- Use sealed, heat-shrink butt splices, such as Molex Perma-Seal, or a soldered connection with heat-shrink tubing. Follow the manufacturer's instructions to ensure a proper splice.



### **DANGER!**

The integrity of the ignition-sensing circuit is critical to the safe operation of the steering system. Follow these instructions carefully. Failure of the ignition-sensing circuit will result in loss of steering control, which could lead to a collision and/or ejection from the boat, causing property damage, personal injury, and/or death.

### **Ignition source options**

On most boats you will have one of two options for an ignition source: you can connect to a single ignition source wire, or you will have to splice into an existing ignition wire.

### **OPTION 1 – Single ignition source**

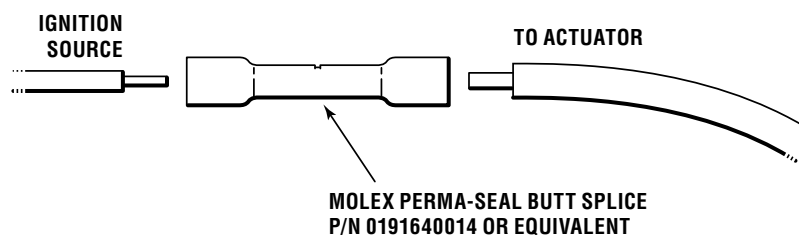

Figure 5-30.



## OPTION 1 – Splice into an existing engine ignition wire

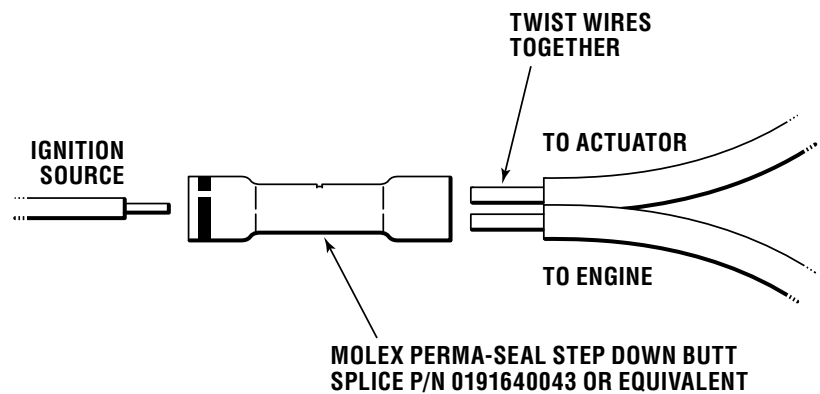

Figure 5-31.

### Application specific instructions

Single-engine: Connect the ignition-sensing wire to the engine ignition.

Twin-engine application: Connect the port actuator sensing wire to the port ignition and the starboard actuator sensing wire to the starboard ignition.

Triple- and quad-engine applications: The ignition-sensing wires must be connected in such a way that an ignition-on signal is received when any of the engine ignition switches are on. Some boats may be wired to deliver such an ignition signal, but you may require one (triple-engine) or two (quad-engine) Dual Ignition Kits (HA1201) to combine the ignition from a pair of engines into a single source.

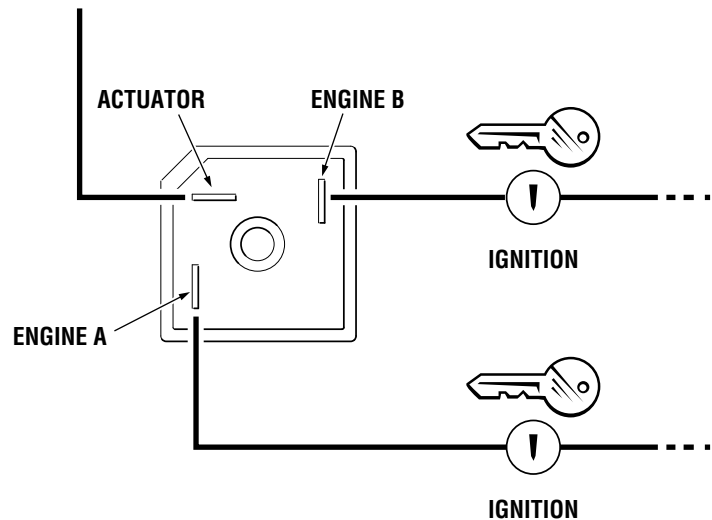

Figure 5-32.

*This page left intentionally blank.*

# 6 Setup and Configuration

Before the Optimus EPS system can be used it must be configured. At a minimum, you need to do the Initial Setup and the Steering Setup. In the Initial Setup you will specify the type of system you are configuring, as well as the number and location of the devices that are installed. In the Steering Setup you will calibrate the steering actuators.



### NOTE

This manual assumes that you are familiar with navigating the CANtrak display menus. If this is not the case, refer to section 2 of Book 65 – System Setup and Configuration Guide – for more information.

## 6.1 First-time power-up

The first few times you turn on your system you will get several warnings and alarms because the system has not yet been fully configured and calibrated. Silence the buzzer by pressing **Mute** on the display.

Press and hold the Menu button for five seconds to show the Dealer Menu PIN entry screen. (Active alarms may hide the Menu button – it is always the right-most button under the display.) Enter your PIN to access the Dealer Menu.

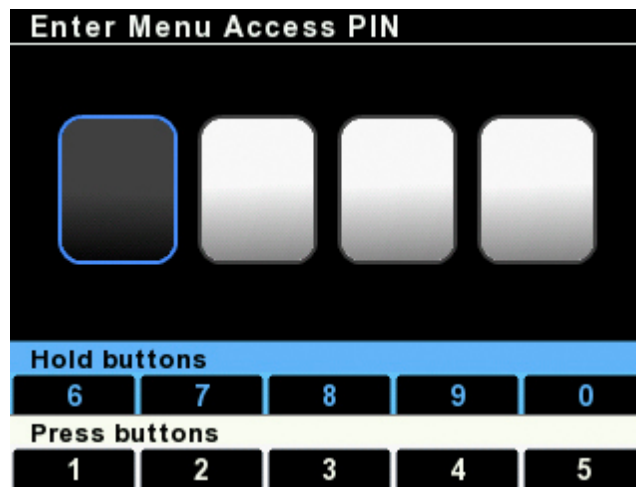

Figure 6-1.



### NOTE

After entering your dealer PIN, the display may revert to an error screen if errors are present. Press the right-most button to scroll through the errors until the dealer menu is displayed.

## 6.2 Initial setup

Initial Setup is performed from the System Setup screen. Navigate to **Dealer Menu > Initial Setup > System** and you will see the setup steps presented in order on the display. It is important to perform these steps in the order shown.

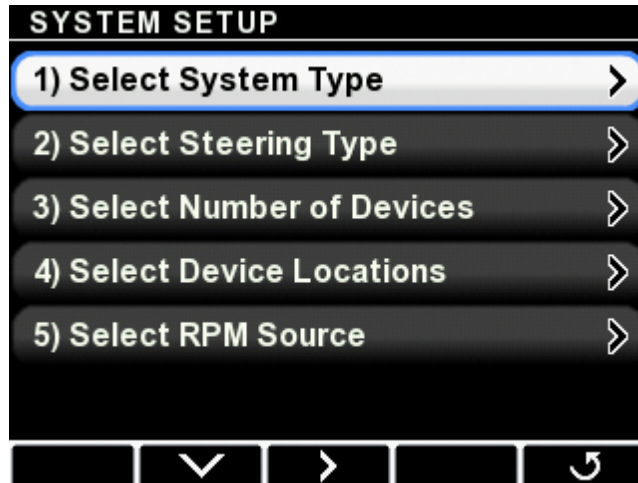

Figure 6-2.

### 6.2.1 Select system type

There are four system types, shown in table 6-1. Select **Optimus EPS**.

System Type	Description
Optimus EPS	Standalone EPS system
Optimus EST	Standalone i7700 (or i6800) EST system
Optimus EPS + EST	EPS system with a standalone i7700 (or i6800) EST system
Optimus 360	Optimus 360 joystick control system

Table 6-1.



#### NOTE

This manual covers only the Optimus EPS system – if you are setting up another system type you will need to refer to Book #65 – Setup and Configuration Guide.

---

## 6.2.2 Select steering type

Select **Outboard Optimus Electric** from the list, as shown in figure 6-3.

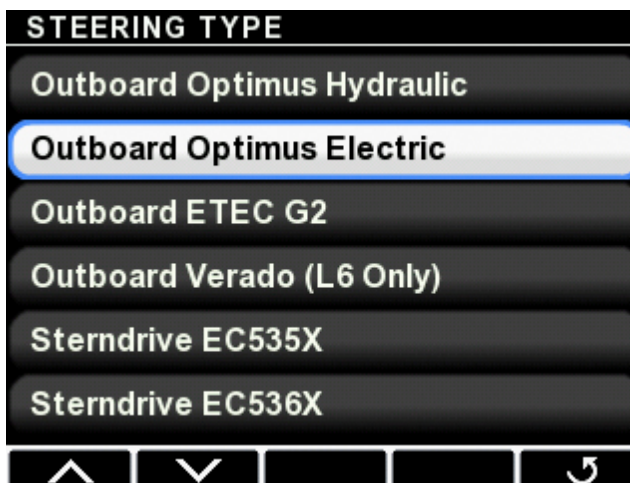

Figure 6-3.

---

## 6.2.3 Select number of devices

The CANtrak will display a list of devices based on the system type. Use the **+** and **-** buttons to change the quantity of each device to match the system.

These parameters tell the system how many of each device to look for on the CAN network. If the numbers do not match you will get repeated error messages from the display.

---

## 6.2.4 Select device locations

Each device on the network must be “instanced” correctly when there are more than one of each type present. Instancing means teaching the system which actuator is port, which is starboard, and which helm is main station, and which is 2nd station.

The CANtrak will list all the devices on the CAN network along with their serial numbers. Match the devices by the serial numbers and use the **+** and **-** buttons to toggle between Port or Stbd, and Main or 2nd (or 3rd in supported systems) station.



### NOTICE!

Damage to the outboard engines may occur if the electric steering actuators are not instanced correctly.

---

## 6.2.5 Select RPM source

The only valid RPM source is the default, CAN3, so you do not need to change anything.

## 6.3 Steering setup

The setup steps in this section are required for all Optimus EPS and Optimus 360 systems. All the steering setup tasks are done from the Steering Setup menu at **Dealer Menu > Initial Setup > Steering**.

### 6.3.1 Configuration (optional)

Skip this step unless you have installed an engine wedge kit (such as Dometic P/N HA5495). Engine wedges are angled shims installed between the engine mounting bracket and the transom to toe-in the engines. Increased toe-in angle will give better joystick performance on hulls with widely spaced engines, such as pontoon boats or catamarans. This parameter tells the SCU how much to correct for this angle.

Use the **+** and **-** buttons to adjust the wedge angle, up to the maximum supported angle of 10°.

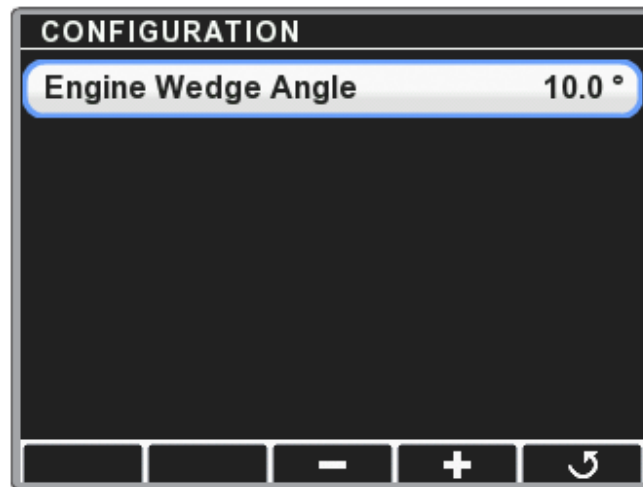

Figure 6-4.

### 6.3.2 Calibrating the Electric Actuators

The calibration procedure teaches the SCU the end-of-travel points for the actuators in the system. The SCU expects to see these end points within a range of values based on the actuator stroke. If the actuator is unable to move through its full stroke the calibration will fail.



#### NOTE

During calibration the steering actuators will move through their full stroke. Ensure there is nothing stopping the engines from traveling the full distance, or calibration could fail.

1. From the steering setup screen, select Calibrate Steering and press **>** to enter the calibration menu, then press **>** again to enter calibration mode.

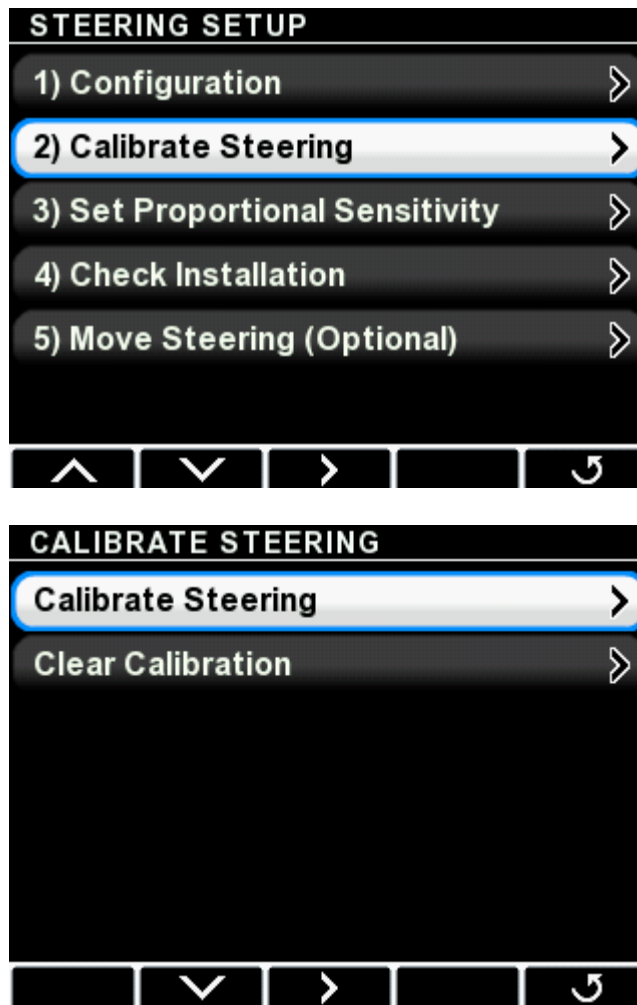

Figure 6-5.

2. The screen will prompt you to steer back and forth to check the actuator instancing. Only the starboard actuator should move. If the port actuator moves, you must correct the instancing or damage may result. Press **Setup** to return to the system setup screen.

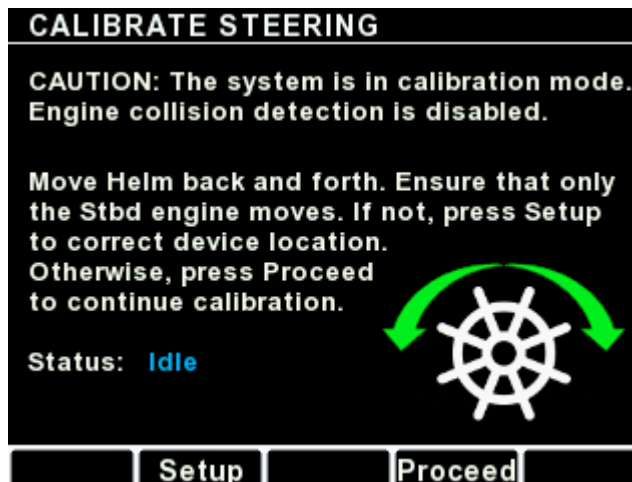

Figure 6-6.

3. Once you've verified that only the starboard actuator moves, press **Proceed** to enter calibration mode. The display will prompt you through the calibration procedure. Follow the instructions on screen, as shown in figure 6-7. Keep turning in the indicated direction until the screen prompts you to stop or change direction.

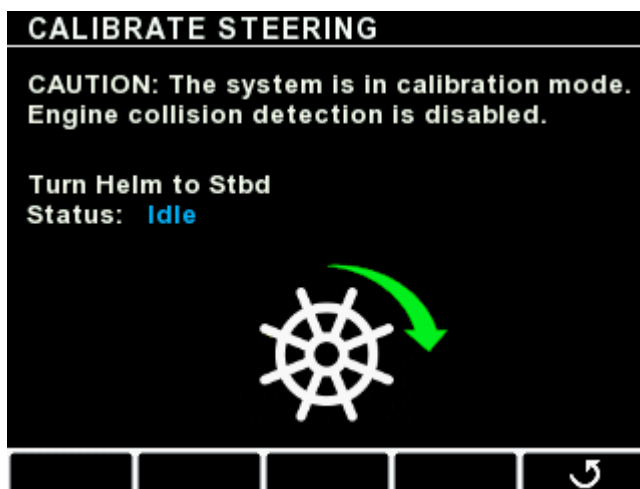

Figure 6-7.

4. If the calibration is successful, you will see the screen in figure 6-8. Exit the screen or power cycle the system to continue.

If the calibration fails, you will see the screen in figure 6-9. Double check the installation and ensure that there is no interference that is preventing the steering actuators from moving through their full stroke. Exit the screen and try again.

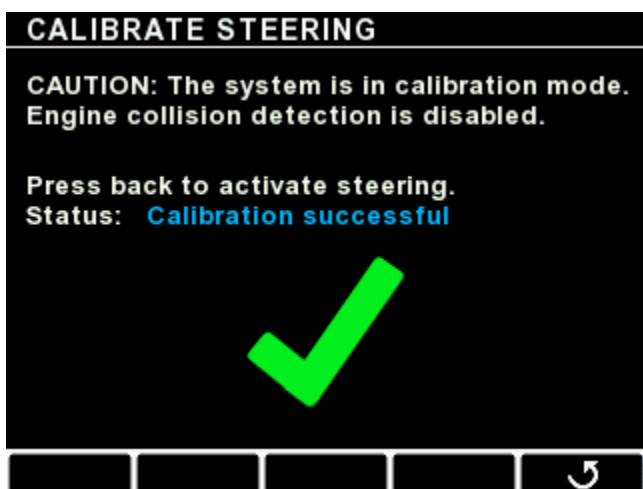

Figure 6-8.

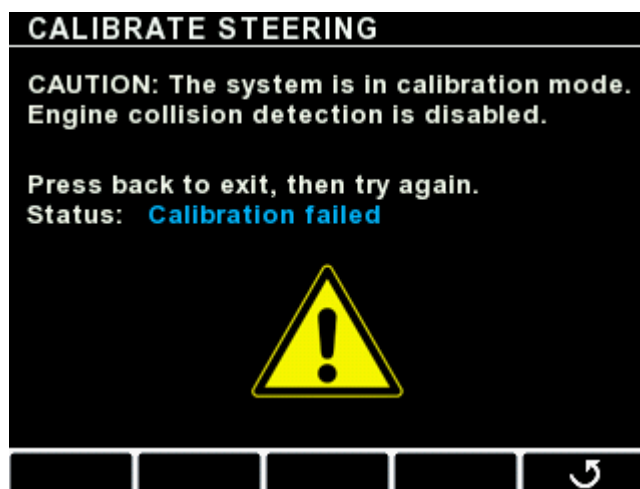

Figure 6-9.



#### NOTE

If calibration fails repeatedly, and you have confirmed there is no interference, contact Technical Support for assistance.



---

### 6.3.3 Set Proportional Sensitivity

Proportional rudder sensitivity is an optional parameter used to increase the helm sensitivity at the neutral rudder position for more responsive steering. The total number of helm turns lock-to-lock is unchanged, so the steering becomes less sensitive as you approach hard over.

Proportional Sensitivity is set in **Steering Setup > Set Proportional Sensitivity**. There are two parameters:

**Proportional Sensitivity Gain:** This parameter controls the increase in sensitivity. The range is from 0.5 to 4.0 and represents a multiplier of the standard helm sensitivity. The default value of 1.0 means there is no change, and a value of 4.0 means the helm sensitivity is four times the normal setting. The multiplier applies at zero steering angle, then decreases linearly as steering angle increases. We suggest that you start with a gain of no more than 2 and sea trial before increasing the gain.

**Proportional Sensitivity Range:** This is the steering angle range (from zero degrees) over which the Sensitivity Gain is applied. Adjust the parameter between 0 and the maximum steering angle of 30 degrees

---

### 6.3.4 Check installation

At this point you have almost completed the installation and setup of the Optimus EPS with Electric Actuator. The final step is to check the installation for interference. Follow the interference check procedure in section 3.1.2 and correct any interference before handing the boat over to the customer.



#### NOTICE!

- Failure to perform these checks may result in damage to the Electric Actuator, which could affect operation of the steering system.
- Do not hand the boat over to the customer without performing these checks and correcting any interference.
- In some cases, you may need to install tilt limiting switches.

---

### 6.3.5 Move Steering (optional)

The Move Steering function allows the system installer or service technician a convenient way to steer each Electric Actuator individually. It is intended primarily as a diagnostic tool, but it can be helpful in the performance of some service tasks. It is not a required step for initial setup.

To use this function, select **Move Steering**, then select either **Move port steering** or **Move stbd steering**. Once in this mode, turning the helm will move the selected steering actuator.



#### NOTICE!

In this mode the actuator's speed is reduced and collision detection is disabled. Use caution when steering or damage to the outboard engine cowlings may occur.

If the actuators are calibrated, backing out of the Move Steering mode and turning the helm will cause the actuators to auto-align.

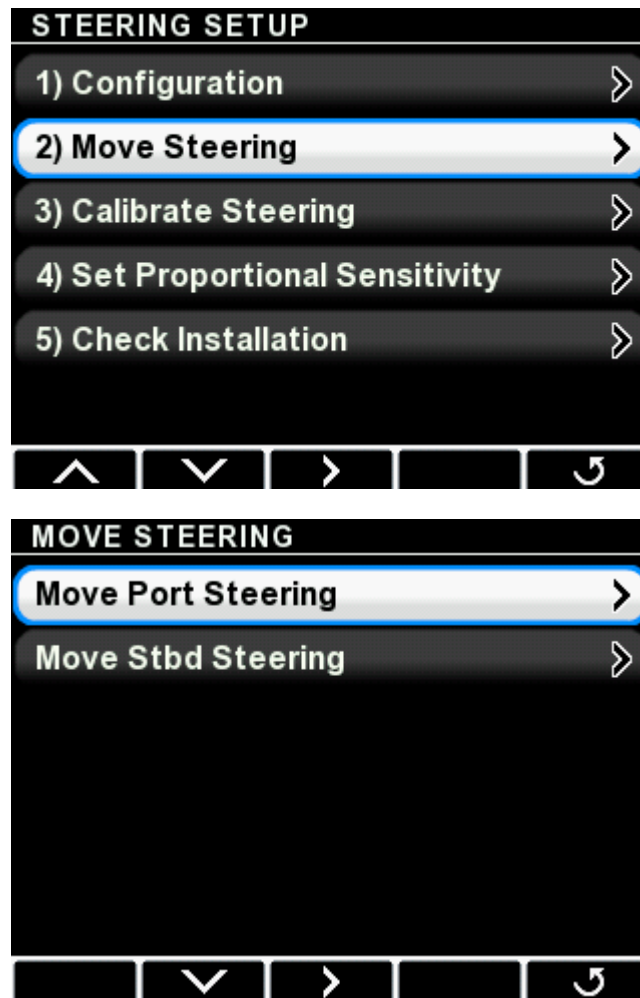

Figure 6-10.

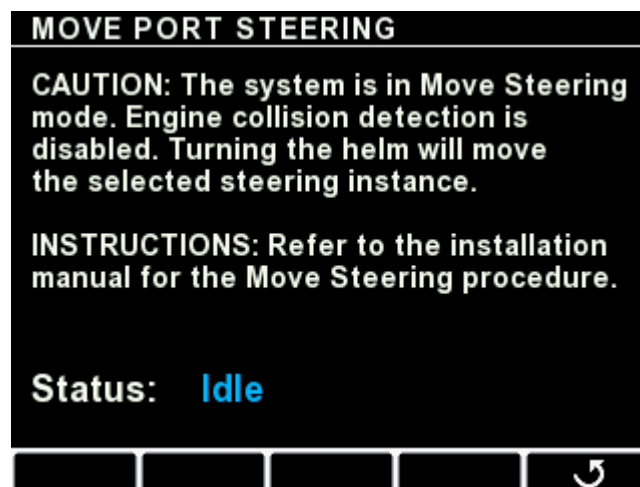

Figure 6-11.

# 7 Maintenance and Troubleshooting

## 7.1 Maintenance schedule

Follow the routine maintenance schedules shown here to ensure years of safe and reliable service from your Optimus EPS with Electric Actuator.

### 7.1.1 Owner/Operator

#### Before every use

- Perform the system inspection detailed in section 3.1.1.



#### WARNING!

Do not operate the boat if any component is not in proper working order. It may result in a loss of steering control, which could lead to a collision and/or ejection from the boat, causing property damage, personal injury, and/or death.

#### After use

- Install the CANtrak sun cover.
- Rinse off the Electric Actuator(s) thoroughly, using only fresh, clean water at low pressure. Never use high-pressure water from a hose nozzle or pressure washer.
- Do not use acetone, or cleaners containing ammonia, acids, or any other corrosive ingredients, on any Optimus components.
- Some products formulated for cleaning fiberglass hulls are known to aggressively corrode stainless steel shafts. If using a hull cleaner, avoid overspray on to the Electric Actuators. Rinse off any overspray immediately with fresh, clean water.

### 7.1.2 Qualified marine mechanic

**After the first 20 hours, and every 100 hours** (or six months, whichever comes first) thereafter

- Perform the system inspection detailed in section 3.1.1.
- Check all fasteners throughout the steering system. Tighten to the correct torque specification as required.
- Check for mechanical play or slop throughout the steering system. Correct as required.
- Inspect for signs of corrosion. Contact Dometic if more than superficial spotting is found.
- Check all harnesses (not just the actuator harness) for signs of chafing or wear.
- Use a grease gun to grease the support bracket grease nipples with a quality marine grease.

**Every 200 hours** (or twelve months, whichever comes first)

- All points noted above
- Remove support rod from the engine tilt tube and clean the support rod, support brackets and tilt tube.
- Grease the support rod liberally with a good quality marine grease and re-install. Refer to section 5.2 for more information. Be sure to replace all washers and spacers in the correct orientation for the engine application.
- Remove the steering wheel(s) and re-grease the shaft.



**WARNING!**

Service must only be performed by qualified marine mechanics with a working knowledge of the system.

## 7.2 Troubleshooting guide

Most problems with Optimus EPS usually occur when an instruction is not followed, and usually show up immediately on power up. Listed below are the most common faults you'll encounter, along with their most likely causes.

### FAULT

#### 1. CANtrak does not turn ON?

### CAUSE

- Batteries not turned ON, or in poor working condition.
- Ignition wires disconnected.
- CANtrak connection damaged and/or not connected.

### SOLUTION

- Load test batteries.
- Confirm all connections are in place.
- Inspect wires for damage.

#### 2. High/Low Speed wheel turn setting not working

- Tachometer is not relaying information.
- CANtrak NOT writing proper information.

- Confirm Tachometer is operating properly (check connections).
- Confirm that your settings have been saved. If they are not saved, contact Tech support.

# Appendix A

## A.1 Helm templates

### A.1.1 Front Mount Helm (EH1510/EH1512)



#### NOTICE!

If this template has been downloaded electronically or copied from another document, please verify all template dimensions prior to cutting. Print/copy reproductions may be scaled differently.

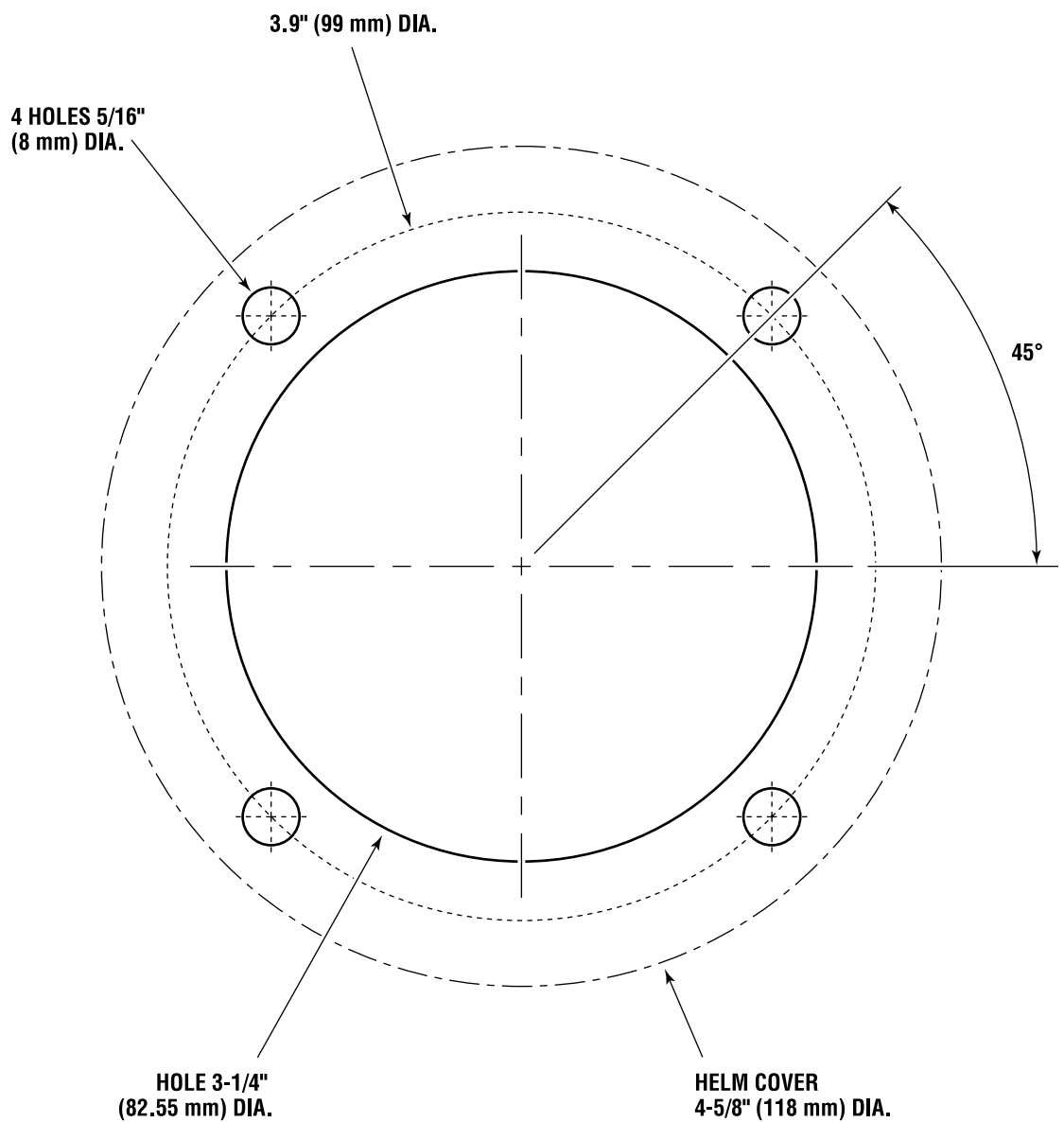

Figure A-1. Front Mount Helm Template.

*This page left intentionally blank.*



*This page left intentionally blank.*



### A.1.3 Classic Tilt Helm (EH1550/EH1552)



#### NOTICE!

If this template has been downloaded electronically or copied from another document, please verify all template dimensions prior to cutting. Print/copy reproductions may be scaled differently.

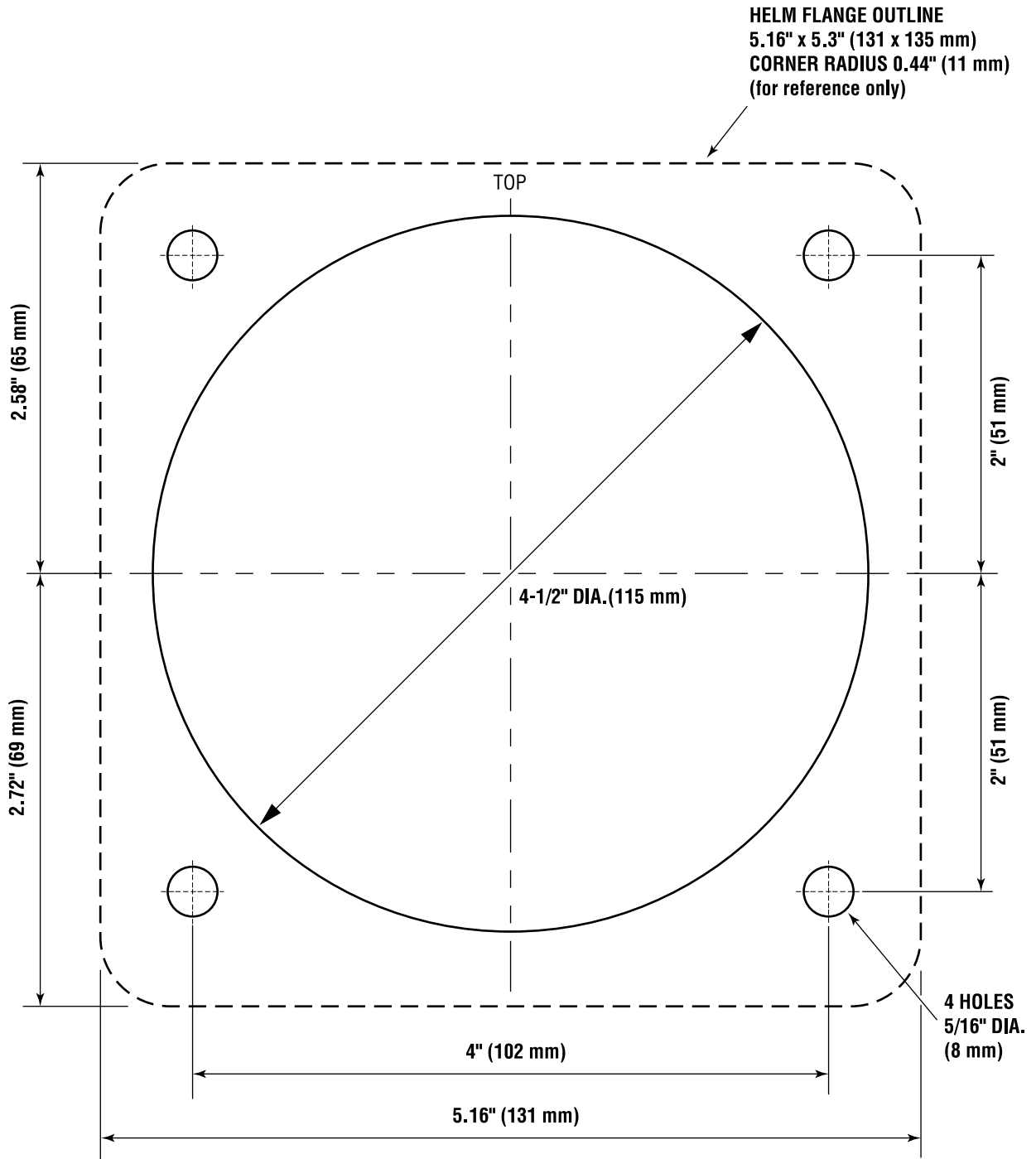

Figure A-3. Classic Tilt Helm Template.

*This page left intentionally blank.*

### A.1.4 Rear Mount Helm (EH1570/EH1572)



#### NOTICE!

If this template has been downloaded electronically or copied from another document, please verify all template dimensions prior to cutting. Print/copy reproductions may be scaled differently.

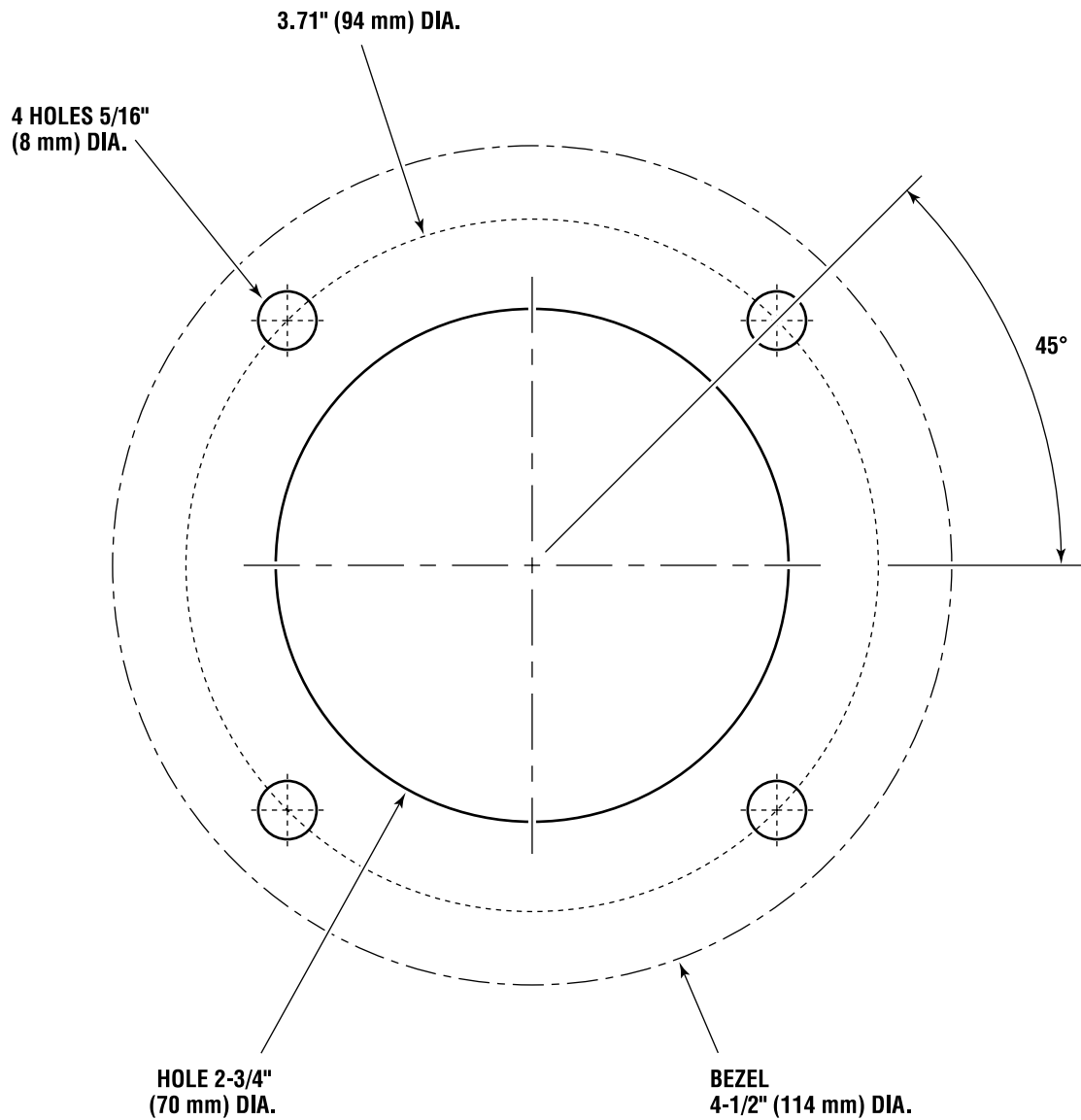

Figure A-4. Rear Mount Helm Template,

*This page left intentionally blank.*

# A.2 CANtrak display template



### NOTICE!

If this template has been downloaded electronically or copied from another document, please verify all template dimensions prior to cutting. Print/copy reproductions may be scaled differently.

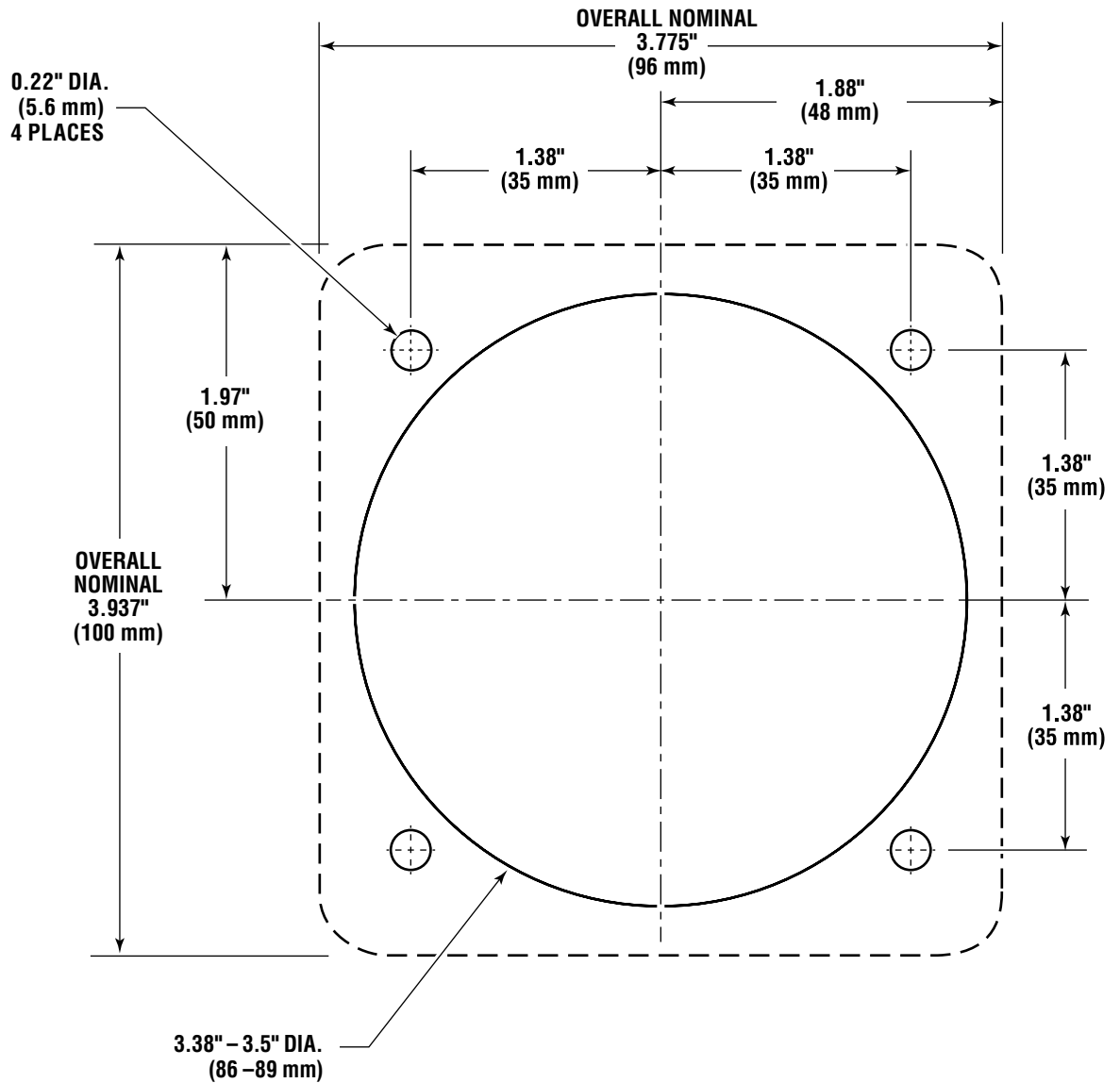

Figure A-5. Color CANtrak Display Mounting Template.

*This page left intentionally blank.*

## A.3 Bulkhead fitting template



### NOTICE!

If this template has been downloaded electronically or copied from another document, please verify all template dimensions prior to cutting. Print/copy reproductions may be scaled differently.

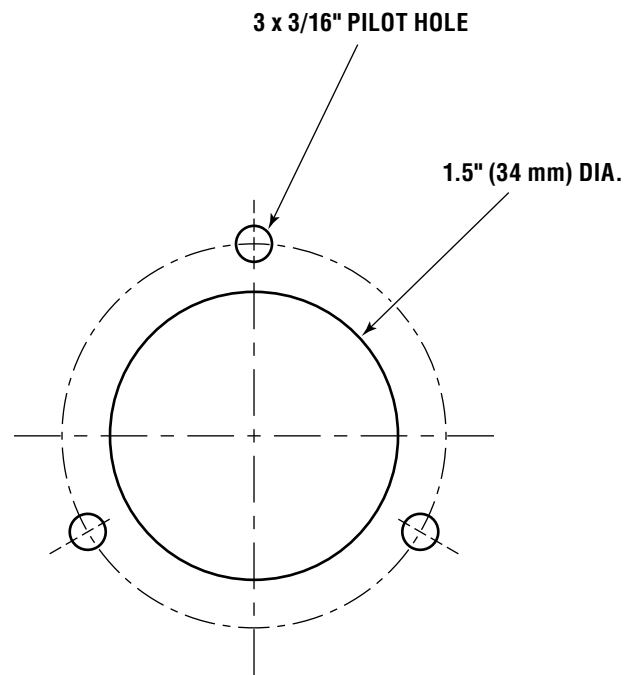

Figure A-6. Bulkhead Fitting Template.



*This page left intentionally blank.*



# APPENDIX B

## B.1 Bolt torque specifications

These are the recommended maximum torque values for reusable dry bolts. Bolts should be torqued to this value +0% - 20%. For lubricated bolts, multiply the dry bolt torque values by 0.75.

Values are stated in: in-lbs (N.m)

Bolt Size	18-8SS	Brass	Bolt Size	18-8SS	Brass	Bolt Size	18-8SS	Brass
2-56	2.5 (.282)	2.0 (.226)	6-32	9.6 (1.08)	4.9 (.554)	5/16"-18	132.0 (14.91)	107.0 (12.10)
2-64	3.0 (.338)	2.5 (.282)	6-40	12.0 (1.35)	9.9 (1.12)	5/16"-24	142.0 (16.04)	116.0 (13.11)
3-48	3.9 (.440)	3.2 (.361)	8-32	20.0 (2.25)	16.0 (1.81)	3/8"-16	236.0 (26.66)	192.0 (21.71)
3-56	4.4 (.497)	3.6 (.407)	8-36	22.0 (2.48)	18.0 (2.03)	3/8"-24	259.0 (29.20)	212.0 (23.97)
4-40	5.2 (.587)	4.3 (.486)	10-24	23.0 (2.59)	19.0 (2.14)			
4-48	6.6 (.740)	5.4 (.610)	10-32	32.0 (3.61)	26.0 (2.94)			
5-40	7.7 (.869)	6.3 (.712)	1/4"-20	75.0 (8.47)	62.0 (7.01)			
5-44	9.4 (1.06)	7.7 (.869)	1/4"-28	94.0 (10.6)	77.0 (8.70)			

Values are stated in: ft-lbs (N.m)

Bolt Size	18-8SS	Brass	Bolt Size	18-8SS	Brass	Bolt Size	18-8SS	Brass
7/16"-14	31.0 (42.00)	26.0 (35.25)	5/8"-11	93.0 (126.09)	76.0 (103.04)	1"-8	287.0 (389.12)	235.0 (318.62)
7/16"-20	33.0 (44.74)	27.0 (36.61)	5/8"-18	104.0 (141.00)	85.0 (115.24)	1"-14	259.0 (351.16)	212.0 (287.43)
1/2"-13	43.0 (58.30)	35.0 (47.45)	3/4"-10	128.0 (173.55)	104.0 (141.00)			
1/2"-20	45.0 (61.01)	37.0 (50.17)	3/4"-16	124.0 (168.12)	102.0 (138.29)			
9/16"-12	57.0 (77.28)	47.0 (63.72)	7/8"-9	194.0 (236.03)	159.0 (215.58)			
9/16"-18	63.0 (85.42)	51.0 (69.15)	7/8"-14	193.0 (261.67)	158.0 (214.22)			

## B.2 System specifications

Operating voltage	12V DC nominal (9V min/16V max per SAE J1455)
Current draw, average	8A per actuator
Current draw, peak operating	40A per actuator
Current draw, maximum	55A per actuator
Circuit breaker rating	60A per actuator (not supplied by Dometic)
Number of wheel turns	Variable from 3.5 to 8
Steering angle	Up to 30° in each direction



# Warranty

## Statement of limited warranty

---

We warrant to the original retail purchaser that **Marine Canada Acquisition Inc. DBA SEASTAR SOLUTIONS** (herein forward referred to as SeaStar Solutions) products have been manufactured free from defects in materials and workmanship. This warranty is effective for two years from date of purchase, excepting that where **SeaStar Solutions** products are used commercially or in any rental or income producing activity, then this warranty is limited to one year from the date of purchase.

We will provide replacement product without charge, for any **SeaStar Solutions** product meeting this warranty, which is returned (freight prepaid) within the warranty period to the dealer from whom such product were purchased, or to us at the appropriate address. In such a case **SeaStar Solutions** products found to be defective and covered by this warranty, will be replaced at **SeaStar Solutions'** option, and returned to the customer.

The above quoted statement is an extract from the complete **SeaStar Solutions** products warranty statement. A complete warranty policy is available in our **SeaStar Solutions** products catalogue.

*For more information please visit our website:*

**[www.seastarsolutions.com/support-2/warranty-2/seastar-solutions-warranty](http://www.seastarsolutions.com/support-2/warranty-2/seastar-solutions-warranty)**

---

## Return goods procedure

Contact our warranty department at [Marine.Warranty@dometic.com](mailto:Marine.Warranty@dometic.com) for instructions.

---

## Technical support

Phone: 604.248.3858

email: [seastar@dometic.com](mailto:seastar@dometic.com)

Hours: Monday to Friday 05:00 – 15:30 PST

Mobile living made easy.

---



© 2020 DOMETIC

PRINTED IN CANADA 07/20

---

Please scan  
this QR code  
and watch our  
latest **Boating  
Safety** video.



DOMETIC VANCOUVER  
3831 NO.6 ROAD  
RICHMOND, B.C.  
CANADA V6V 1P6

[www.dometic.com](http://www.dometic.com)

ISO 25197:2012



FORM NO. 682220 REV. C

